



A D T

FCC TEST REPORT (15.247)

REPORT NO.: RF980922L13

MODEL NO.: ZF7731

RECEIVED: Sep. 22 2009

TESTED: Sep. 25 ~ Oct. 8, 2009

ISSUED: Oct. 8, 2009

Applicant's Company	Senao Networks, Inc.
Applicant Address	3F, No. 529, Chung Cheng Rd., Hsintien, Taipei, Taiwan
FCC ID	U2M-ZF7731
Manufacturer's Company	Senao Networks, Inc.
Manufacturer Address	3F, No. 529, Chung Cheng Rd., Hsintien, Taipei, Taiwan

ISSUED BY: Bureau Veritas Consumer Products Services (H.K.) Ltd., Taoyuan Branch

LAB LOCATION: No. 47, 14th Ling, Chia Pau Tsuen, Lin Kou Hsiang, Taipei Hsien, 244 Taiwan

This test report consists of 168 pages in total. It may be duplicated completely for legal use with the approval of the applicant. It should not be reproduced except in full, without the written approval of our laboratory. The client should not use it to claim product endorsement by TAF or any government agencies. The test results in the report only apply to the tested sample.





A D T

TABLE OF CONTENTS

1.	CERTIFICATION	4
2.	SUMMARY OF TEST RESULTS	5
2.1	MEASUREMENT UNCERTAINTY	5
3.	GENERAL INFORMATION	6
3.1	GENERAL DESCRIPTION OF EUT	6
3.2	DESCRIPTION OF TEST MODES	7
3.2.1	CONFIGURATION OF SYSTEM UNDER TEST	8
3.2.2	TEST MODE APPLICABILITY AND TESTED CHANNEL DETAIL	12
3.3	GENERAL DESCRIPTION OF APPLIED STANDARDS	14
3.4	DESCRIPTION OF SUPPORT UNITS	14
4.	TEST TYPES AND RESULTS	15
4.1	RADIATED EMISSION MEASUREMENT	15
4.1.1	LIMITS OF RADIATED EMISSION MEASUREMENT	15
4.1.2	TEST INSTRUMENTS	16
4.1.3	TEST PROCEDURES	17
4.1.4	DEVIATION FROM TEST STANDARD	17
4.1.5	TEST SETUP	18
4.1.6	EUT OPERATING CONDITIONS	18
4.1.7	TEST RESULTS	19
4.2	CONDUCTED EMISSION MEASUREMENT	39
4.2.1	LIMITS OF CONDUCTED EMISSION MEASUREMENT	39
4.2.2	TEST INSTRUMENTS	39
4.2.3	TEST PROCEDURES	40
4.2.4	DEVIATION FROM TEST STANDARD	40
4.2.5	TEST SETUP	41
4.2.6	EUT OPERATING CONDITIONS	41
4.2.7	TEST RESULTS	42
4.3	6dB BANDWIDTH MEASUREMENT	50
4.3.1	LIMITS OF 6dB BANDWIDTH MEASUREMENT	50
4.3.2	TEST INSTRUMENTS	50
4.3.3	TEST PROCEDURE	50
4.3.4	DEVIATION FROM TEST STANDARD	51
4.3.5	TEST SETUP	51
4.3.6	EUT OPERATING CONDITIONS	51
4.3.7	TEST RESULTS	52
4.4	MAXIMUM PEAK OUTPUT POWER	74
4.4.1	LIMITS OF MAXIMUM PEAK OUTPUT POWER MEASUREMENT	74
4.4.2	INSTRUMENTS	74
4.4.3	TEST PROCEDURES	74
4.4.4	DEVIATION FROM TEST STANDARD	75
4.4.5	TEST SETUP	75
4.4.6	EUT OPERATING CONDITIONS	75



A D T

4.4.7	TEST RESULTS.....	76
4.5	POWER SPECTRAL DENSITY MEASUREMENT.....	120
4.5.1	LIMITS OF POWER SPECTRAL DENSITY MEASUREMENT	120
4.5.2	TEST INSTRUMENTS	120
4.5.3	TEST PROCEDURE	120
4.5.4	DEVIATION FROM TEST STANDARD	121
4.5.5	TEST SETUP	121
4.5.6	EUT OPERATING CONDITION	121
4.5.7	TEST RESULTS.....	122
4.6	BAND EDGES MEASUREMENT	144
4.6.1	LIMITS OF BAND EDGES MEASUREMENT	144
4.6.2	TEST INSTRUMENTS	144
4.6.3	TEST PROCEDURE	145
4.6.4	DEVIATION FROM TEST STANDARD	146
4.6.5	EUT OPERATING CONDITION	146
4.6.6	TEST RESULTS.....	146
4.7	ANTENNA REQUIREMENT	165
4.7.1	STANDARD APPLICABLE	165
4.7.2	ANTENNA CONNECTED CONSTRUCTION.....	165
5.	PHOTOGRAPHS OF THE TEST CONFIGURATION.....	166
6.	INFORMATION ON THE TESTING LABORATORIES	167
7.	APPENDIX A - MODIFICATIONS RECORDERS FOR ENGINEERING CHANGES TO THE EUT BY THE LAB	168



A D T

1. CERTIFICATION

PRODUCT: Zone Flex 7731 802.11n Outdoor Point to Point Bridge

MODEL NO.: ZF7731

BRAND: Ruckus

APPLICANT: Senao Networks Inc.

TEST SAMPLE: ENGINEERING SAMPLE

TESTED: Sep. 25 ~ Oct. 8, 2009

STANDARDS: FCC Part 15, Subpart C (Section 15.247)

ANSI C63.4-2003

The above equipment has been tested by **Bureau Veritas Consumer Products Services (H.K.) Ltd., Taoyuan Branch**, and found compliance with the requirement of the above standards. The test record, data evaluation & Equipment Under Test (EUT) configurations represented herein are true and accurate accounts of the measurements of the sample's EMC characteristics under the conditions specified in this report.

PREPARED BY : Annie Chang , **DATE:** Oct. 8, 2009
(Annie Chang / Senior Specialist)

TECHNICAL ACCEPTANCE : Jamison Chan , **DATE:** Oct. 8, 2009
Responsible for RF (Jamison Chan / Supervisor)

APPROVED BY : Ken Liu , **DATE:** Oct. 8, 2009
(Ken Liu / Assistant Manager)



A D T

2. SUMMARY OF TEST RESULTS

The EUT has been tested according to the following specifications:

APPLIED STANDARD: FCC PART 15, SUBPART C (SECTION 15.247)			
STANDARD SECTION	TEST TYPE AND LIMIT	RESULT	REMARK
15.207	AC Power Conducted Emission	PASS	Meet the requirement of limit. Minimum passing margin is -9.43dB at 0.524MHz.
15.247(a)(2)	Spectrum Bandwidth of a Direct Sequence Spread Spectrum System Limit: min. 500kHz	PASS	Meet the requirement of limit.
15.247(b)	Maximum Peak Output Power Limit: max. 30dBm	PASS	Meet the requirement of limit.
15.247(d)	Radiated Emissions Limit: Table 15.209	PASS	Meet the requirement of limit. Minimum passing margin is -0.04dB at 11570.00MHz.
15.247(e)	Power Spectral Density Limit: max. 8dBm	PASS	Meet the requirement of limit.
15.247(d)	Band Edge Measurement Limit: 30dB less than the peak value of fundamental frequency	PASS	Meet the requirement of limit.

2.1 MEASUREMENT UNCERTAINTY

Where relevant, the following measurement uncertainty levels have been estimated for tests performed on the EUT as specified in CISPR 16-4-2:

This uncertainty represents an expanded uncertainty expressed at approximately the 95% confidence level using a coverage factor of $k = 2$.

MEASUREMENT	FREQUENCY	UNCERTAINTY
Conducted emissions	150kHz~30MHz	2.44 dB
Radiated emissions	30MHz ~ 1GHz	3.78 dB
	Above 1GHz	2.89 dB



3. GENERAL INFORMATION

3.1 GENERAL DESCRIPTION OF EUT

PRODUCT	Zone Flex 7731 802.11n Outdoor Point to Point Bridge
MODEL NO.	ZF7731
FCC ID	U2M-ZF7731
POWER SUPPLY	12Vdc from Adapter 48Vdc from POE
MODULATION TYPE	BPSK
MODULATION TECHNOLOGY	OFDM
TRANSFER RATE	802.11a: 54.0/ 48.0/ 36.0/ 24.0/ 18.0/ 12.0/ 9.0/ 6.0Mbps Draft 802.11n: up to 270.0Mbps
OPERATING FREQUENCY	5745~5825MHz
NUMBER OF CHANNEL	5 for 802.11a & draft 802.11n (20MHz) 2 for draft 802.11n (40MHz)
OUTPUT POWER	82.420mW
ANTENNA TYPE	Refer to note below
I/O PORTS	Refer to user's manual
DATA CABLE	NA
ACCESSORY DEVICES	PoE, adapter(for PoE use)

NOTE:

- The EUT was operated with following PoE:

MODEL:	NPE-5818at
---------------	------------

The adapter of PoE:

BRAND:	Ruckus
MODEL:	GS60A48
INPUT:	100-240Vac, 50-60Hz, 1.4A
OUTPUT:	48Vdc, 1.25A
POWER LINE:	1.8m non-shielded cable with one core

- The EUT is a Zone Flex 7731 802.11n Outdoor Point to Point Bridge. The functions of EUT listed as below:

	TEST STANDARD	REFERENCE REPORT
WLAN 802.11a, draft 802.11n (5745~5825 MHz)	FCC Part 15, Subpart C (Section 15.247)	RF980922L13
WLAN 802.11a, draft 802.11n (5180~ 5240MHz)	FCC Part 15, Subpart E (Section 15.407)	RF980922L13-1



3. The frequency bands used in this EUT are listed as follows:

Frequency Band (MHz)	5180~5240	5745~5825
802.11a	√	√
Draft 802.11n (20MHz)	√	√
Draft 802.11n (40MHz)	√	√

4. The EUT incorporates a MIMO function. Physically, the EUT provides two completed transmitters and two receivers.

MODULATION MODE	TX FUNCTION	
	INTERNAL ANTENNA	EXTERNAL ANTENNA
802.11a	2TX	2TX
Draft 802.11n (20MHz)	2TX	2TX
Draft 802.11n (40MHz)	2TX	2TX

5. The internal and external works separately. In user FW, when external antenna plug in, the major transmission would program from external antenna. Two antennas will not transmit simultaneously. It was controlled by user FW.

6. The following antennas were applied to the EUT:

ITEM	TYPE	CONNECTOR	GAIN	OPTION
INTERNAL ANTENNA	Patch	U.FL	14dBi	X
EXTERNAL ANTENNA	Patch	N-Type	23dBi	Option

7. The above EUT information was declared by manufacturer and for more detailed features description, please refer to the manufacturer's specifications or user's manual.

3.2 DESCRIPTION OF TEST MODES

5 channels are provided for 802.11a, draft 802.11n (20MHz):

CHANNEL	FREQUENCY	CHANNEL	FREQUENCY
149	5745MHz	161	5805MHz
153	5765MHz	165	5825MHz
157	5785MHz		

2 channels are provided for draft 802.11n (40MHz):

CHANNEL	FREQUENCY	CHANNEL	FREQUENCY
151	5755MHz	159	5795MHz

3.2.1 CONFIGURATION OF SYSTEM UNDER TEST

Mode A:

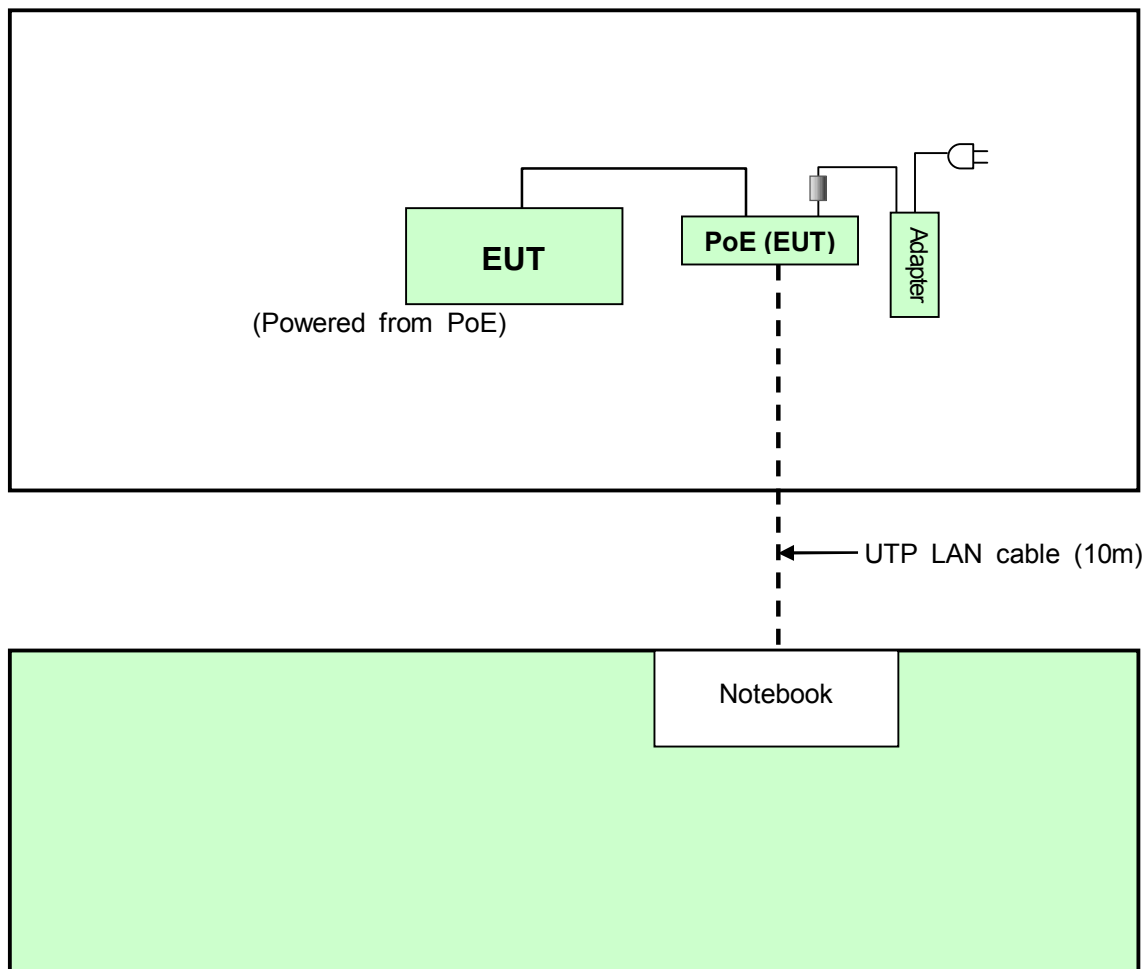

Mode B:

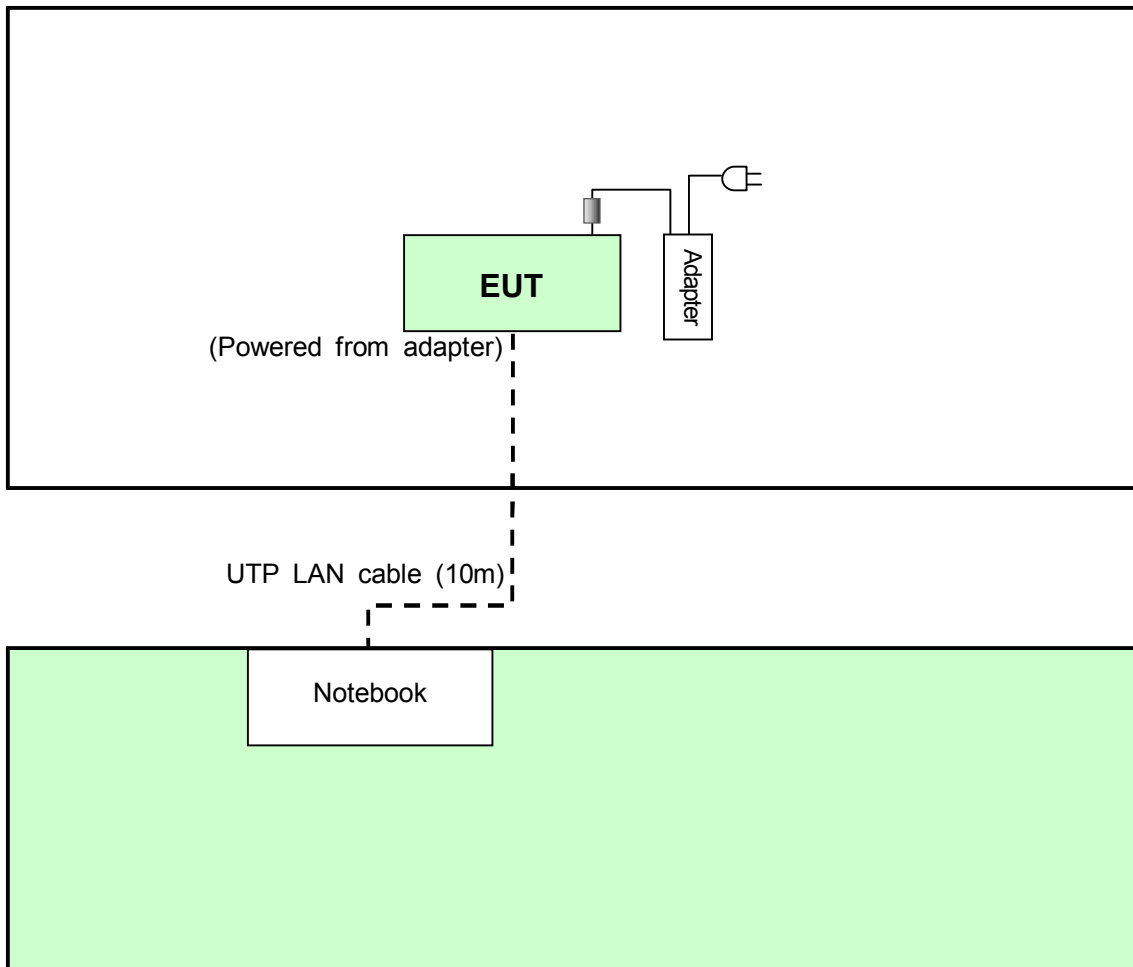

Mode C:

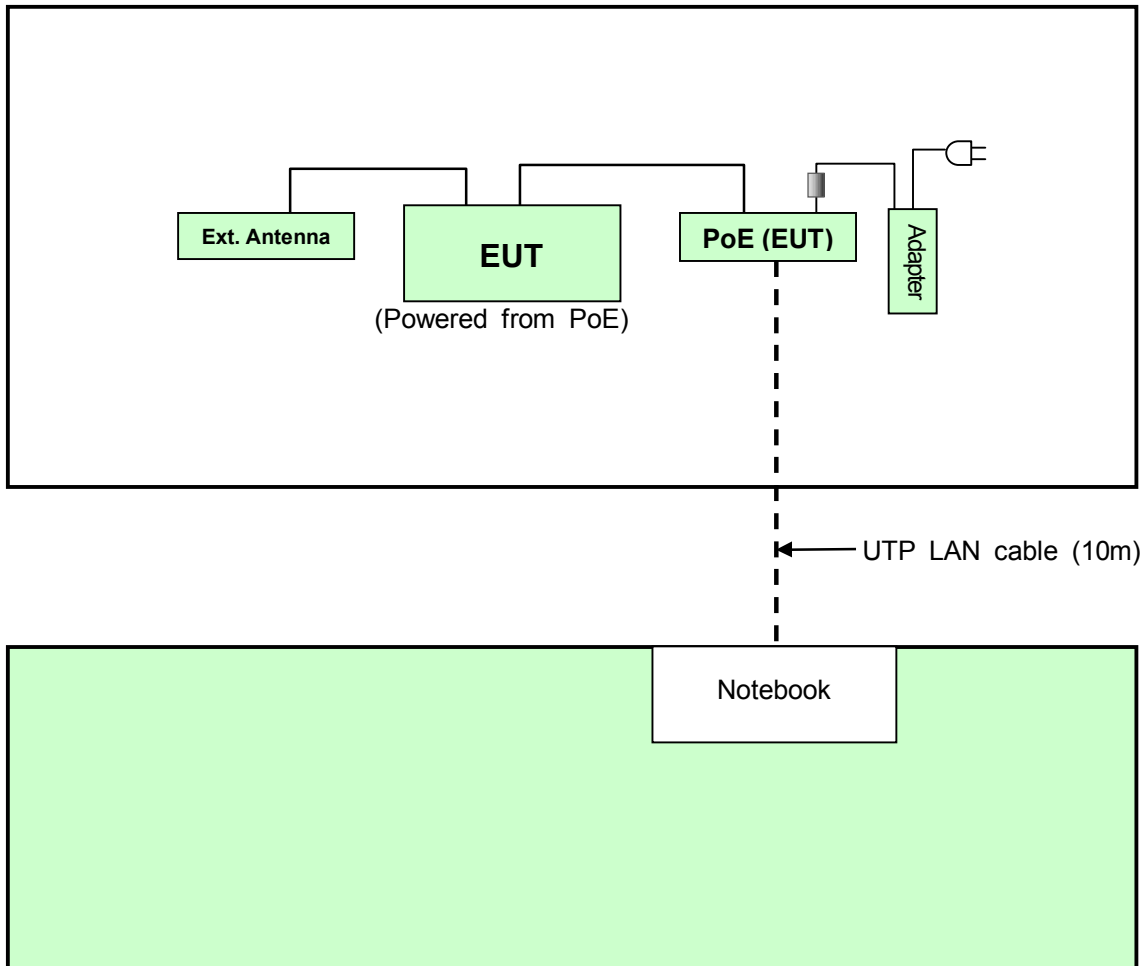

Mode D:

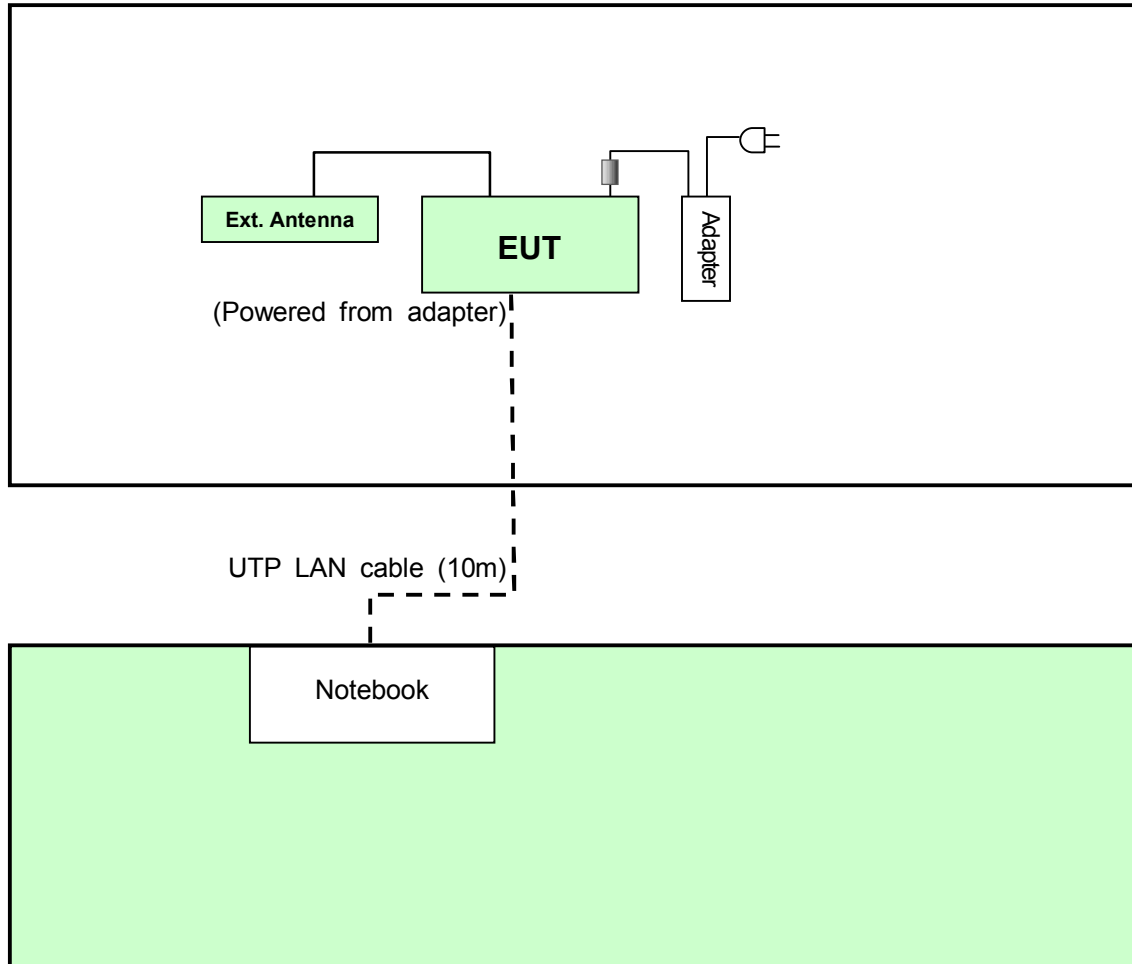



3.2.2 TEST MODE APPLICABILITY AND TESTED CHANNEL DETAIL

EUT CONFIGURE MODE	APPLICABLE TO				DESCRIPTION	
	RE≥1G	RE<1G	PLC	APCM	Antenna	Power Source
A	√	√	√	√	Internal	Powered from POE
B	-	√	√	-		Powered from Adapter
C	√	√	√	√	External	Powered from POE
D	-	√	√	-		Powered from Adapter

Where **RE≥1G**: Radiated Emission above 1GHz **RE<1G**: Radiated Emission below 1GHz
PLC: Power Line Conducted Emission **APCM**: Antenna Port Conducted Measurement

NOTE: "-" means no effect.

RADIATED EMISSION TEST (ABOVE 1GHz):

- Pre-Scan has been conducted to determine the worst-case mode from all possible combinations between available modulations, data rates, XYZ axis and antenna ports (if EUT with antenna diversity architecture).
- Following channel(s) was (were) selected for the final test as listed below.

EUT CONFIGURE MODE	MODE	AVAILABLE CHANNEL	TESTED CHANNEL	MODULATION TECHNOLOGY	MODULATION TYPE	DATA RATE (Mbps)	AXIS
A	802.11a	149 to 165	149, 157, 165	OFDM	BPSK	6.0	Z
C	802.11a	149 to 165	149, 157, 165	OFDM	BPSK	6.0	X
A	Draft 802.11n (20MHz)	149 to 165	149, 157, 165	OFDM	BPSK	6.5	Z
C	Draft 802.11n (20MHz)	149 to 165	149, 157, 165	OFDM	BPSK	6.5	X
A	Draft 802.11n (40MHz)	151 to 159	151, 159	OFDM	BPSK	13.5	Z
C	Draft 802.11n (40MHz)	151 to 159	151, 159	OFDM	BPSK	13.5	X

RADIATED EMISSION TEST (BELOW 1GHz):

- Pre-Scan has been conducted to determine the worst-case mode from all possible combinations between available modulations, data rates, XYZ axis and antenna ports (if EUT with antenna diversity architecture).
- Following channel(s) was (were) selected for the final test as listed below.

EUT CONFIGURE MODE	MODE	AVAILABLE CHANNEL	TESTED CHANNEL	MODULATION TECHNOLOGY	MODULATION TYPE	DATA RATE (Mbps)	AXIS
A & B	Draft 802.11n (20MHz)	149 to 165	157	OFDM	BPSK	6.0	Z
C & D	Draft 802.11n (20MHz)	149 to 165	157	OFDM	BPSK	6.0	X



POWER LINE CONDUCTED EMISSION TEST:

- Pre-Scan has been conducted to determine the worst-case mode from all possible combinations between available modulations, data rates and antenna ports (if EUT with antenna diversity architecture).
- Following channel(s) was (were) selected for the final test as listed below.

EUT CONFIGURE MODE	MODE	AVAILABLE CHANNEL	TESTED CHANNEL	MODULATION TECHNOLOGY	MODULATION TYPE	DATA RATE (Mbps)
A ~ D	Draft 802.11n (20MHz)	149 to 165	157	OFDM	BPSK	6.0

BANDEDGE MEASUREMENT:

- Pre-Scan has been conducted to determine the worst-case mode from all possible combinations between available modulations, data rates and antenna ports (if EUT with antenna diversity architecture).
- Following channel(s) was (were) selected for the final test as listed below.

EUT CONFIGURE MODE	MODE	AVAILABLE CHANNEL	TESTED CHANNEL	MODULATION TECHNOLOGY	MODULATION TYPE	DATA RATE (Mbps)
A & C	802.11a	149 to 165	149, 165	OFDM	BPSK	6.0
A & C	Draft 802.11n (20MHz)	149 to 165	149, 165	OFDM	BPSK	6.5
A & C	Draft 802.11n (40MHz)	151 to 159	151, 159	OFDM	BPSK	13.5

ANTENNA PORT CONDUCTED MEASUREMENT:

- Pre-Scan has been conducted to determine the worst-case mode from all possible combinations between available modulations, data rates and antenna ports (if EUT with antenna diversity architecture).
- Following channel(s) was (were) selected for the final test as listed below.

EUT CONFIGURE MODE	MODE	AVAILABLE CHANNEL	TESTED CHANNEL	MODULATION TECHNOLOGY	MODULATION TYPE	DATA RATE (Mbps)
A & C	802.11a	149 to 165	149, 157, 165	OFDM	BPSK	6.0
A & C	Draft 802.11n (20MHz)	149 to 165	149, 157, 165	OFDM	BPSK	6.5
A & C	Draft 802.11n (40MHz)	151 to 159	151, 159	OFDM	BPSK	13.5



A D T

3.3 GENERAL DESCRIPTION OF APPLIED STANDARDS

The EUT is a RF Product. According to the specifications of the manufacturer, it must comply with the requirements of the following standards:

FCC Part 15, Subpart C (15.247)

ANSI C63.4-2003

All test items have been performed and recorded as per the above standards.

NOTE: The EUT is also considered as a kind of computer peripheral, because the connection to computer is necessary for typical use. It has been verified to comply with the requirements of FCC Part 15, Subpart B, Class B (DoC). The test report has been issued separately.

3.4 DESCRIPTION OF SUPPORT UNITS

The EUT has been tested as an independent unit together with other necessary accessories or support units. The following support units or accessories were used to form a representative test configuration during the tests.

NO.	PRODUCT	BRAND	MODEL NO.	SERIAL NO.	FCC ID
1	Adapter	AMIGO	AM-121000	NA	NA
2	NOTEBOOK COMPUTER	DELL	PP05L	20375526736	FCC DoC Approved

NO.	SIGNAL CABLE DESCRIPTION OF THE ABOVE SUPPORT UNITS
1	NA
2	10m RJ45 cable

NOTE: 1. All power cords of the above support units are non shielded (1.8m).
2. Item 2 acted as communication partners to transfer data.
3. The support unit 1 was provided by client.



4. TEST TYPES AND RESULTS

4.1 RADIATED EMISSION MEASUREMENT

4.1.1 LIMITS OF RADIATED EMISSION MEASUREMENT

Emissions radiated outside of the specified bands, shall be according to the general radiated limits in 15.209 as following:

FREQUENCIES (MHz)	FIELD STRENGTH (microvolts/meter)	MEASUREMENT DISTANCE (meters)
0.009 ~ 0.490	2400/F(kHz)	300
0.490 ~ 1.705	24000/F(kHz)	30
1.705 ~ 30.0	30	30
30 ~ 88	100	3
88 ~ 216	150	3
216 ~ 960	200	3
Above 960	500	3

NOTE:

1. The lower limit shall apply at the transition frequencies.
2. Emission level (dBuV/m) = 20 log Emission level (uV/m).
3. As shown in 15.35(b), for frequencies above 1000MHz, the field strength limits are based on average detector, however, the peak field strength of any emission shall not exceed the maximum permitted average limits, specified above by more than 20dB under any condition of modulation.



A D T

4.1.2 TEST INSTRUMENTS

<Frequency Range 30MHz~1GHz>

DESCRIPTION & MANUFACTURER	MODEL NO.	SERIAL NO.	CALIBRATED DATE	CALIBRATED UNTIL
ROHDE & SCHWARZ TEST RECEIVER	ESVS 30	841977/008	Apr. 24, 2009	Apr. 23, 2010
SCHAFFNER BILOG Antenna	CBL6111C	2793	Apr. 29, 2009	Apr. 28, 2010
ADT. Turn Table	TT100	0201	NA	NA
ADT. Tower	AT100	0201	NA	NA
Software	ADT_Radiate d_V7.6.15.9.2	NA	NA	NA
ADT RF Switches BOX	EM-H-01-1	1004	Dec. 19, 2008	Dec. 18, 2009
WOKEN RF cable	8D	CABLE-ST10-01	Dec. 19, 2008	Dec. 18, 2009

- NOTE:** 1. The calibration interval of the above test instruments is 12 months. And the calibrations are traceable to NML/ROC and NIST/USA.
 2. The test was performed in Open Site No. 10.
 3. The VCCI Site Registration No. R-1625.
 4. The Industry Canada Reference No. IC 7450E-10.
 5. The FCC Site Registration No. 698148.

<Frequency Range above 1GHz>

DESCRIPTION & MANUFACTURER	MODEL NO.	SERIAL NO.	CALIBRATED DATE	CALIBRATED UNTIL
Agilent Spectrum	8564EC	4208A00659	Jul. 24, 2009	Jul. 23, 2010
Agilent Preamplifier	8449B	3008A01924	Aug. 31, 2009	Aug. 30, 2010
Agilent Preamplifier	8449B	3008A01292	Aug. 10, 2009	Aug. 09, 2010
MITEQ Preamplifier	AMF-6F-2604 00-33-8P	892164	Aug. 31, 2009	Aug. 30, 2010
Schwarzbeck Horn Antenna	BBHA-9170	BBHA9170190	Sep. 24, 2009	Sep. 23, 2010
Schwarzbeck Horn Antenna	BBHA-9120	D130	May 15, 2009	May 14, 2010
ADT. Turn Table	TT100	0201	NA	NA
ADT. Tower	AT100	0201	NA	NA
Software	ADT_Radiate d_V7.6.15.9.2	NA	NA	NA
SUHNER RF cable	SF106-18	PHACAB-1G-40 GHz	Aug. 20, 2009	Aug. 19, 2010

- NOTE:** 1. The calibration interval of the above test instruments is 12 months. And the calibrations are traceable to NML/ROC and NIST/USA.
 2. The test was performed in Open Site No. 10.
 3. The Industry Canada Reference No. IC 7450E-10.
 4. The FCC Site Registration No. 698148.



A D T

4.1.3 TEST PROCEDURES

- a. The EUT was placed on the top of a rotating table 0.8 meters above the ground at a 10-meter open area test site. The table was rotated 360 degrees to determine the position of the highest radiation.
- b. The EUT was set 3 meters away from the interference-receiving antenna, which was mounted on the top of a variable-height antenna tower.
- c. The antenna is a broadband antenna, and its height is varied from one meter to four meters above the ground to determine the maximum value of the field strength. Both horizontal and vertical polarizations of the antenna are set to make the measurement.
- d. For each suspected emission, the EUT was arranged to its worst case and then the antenna was tuned to heights from 1 meter to 4 meters and the rotatable table was turned from 0 degrees to 360 degrees to find the maximum reading.
- e. The test-receiver system was set to Peak Detect Function and Specified Bandwidth with Maximum Hold Mode.
- f. If the emission level of the EUT in peak mode was lower than the limit specified, then testing could be stopped and the peak values of the EUT would be reported. Otherwise the emissions would be re-tested one by one using peak, quasi-peak or average method as specified and then reported in a data sheet.

NOTE:

1. The resolution bandwidth and video bandwidth of test receiver/spectrum analyzer is 120kHz for Quasi-peak detection at frequency below 1GHz.
2. The resolution bandwidth of test receiver/spectrum analyzer is 1MHz and video bandwidth is 3MHz for Peak detection at frequency above 1GHz.
3. The resolution bandwidth of test receiver/spectrum analyzer is 1MHz and the video bandwidth is 10Hz for Average detection (AV) at frequency above 1GHz.
4. All modes of operation were investigated and the worst-case emissions are reported.

4.1.4 DEVIATION FROM TEST STANDARD

No deviation.

4.1.5 TEST SETUP

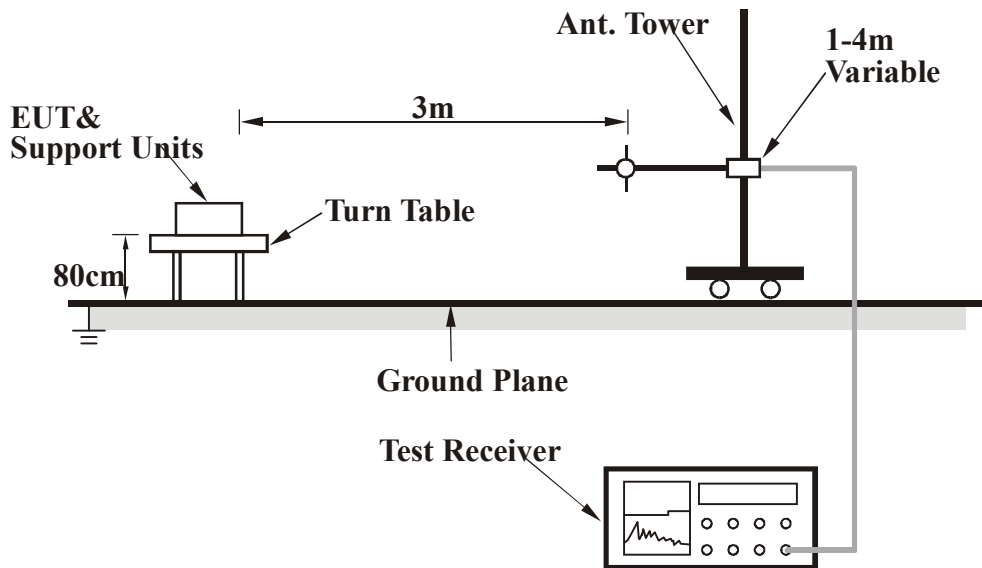

For the actual test configuration, please refer to the attached file (Test Setup Photo).

4.1.6 EUT OPERATING CONDITIONS

- a. Placed the EUT on the testing table.
- b. Prepared a notebook system to act as communication partners and placed them outside of testing area.
- c. The communication partners run a test program (provided by manufacturer) to enable EUT under transmission condition continuously at specific channel frequency via RJ45 cables.



A D T

4.1.7 TEST RESULTS

802.11a OFDM MODULATION

EUT TEST CONDITION		MEASUREMENT DETAIL	
CHANNEL	Channel 149	FREQUENCY RANGE	1 ~ 40GHz
INPUT POWER	120Vac, 60Hz	DETECTOR FUNCTION	Peak (PK) Average (AV)
ENVIRONMENTAL CONDITIONS	28deg. C, 75%RH 1009hPa	TESTED BY	Chad Lee
TEST MODE	A		

ANTENNA POLARITY & TEST DISTANCE: HORIZONTAL AT 3 M								
NO.	FREQ. (MHz)	EMISSION LEVEL (dBuV/m)	LIMIT (dBuV/m)	MARGIN (dB)	ANTENNA HEIGHT (m)	TABLE ANGLE (Degree)	RAW VALUE (dBuV)	CORRECTION FACTOR (dB/m)
1	#5725.00	76.66 PK	87.78	-11.12	1.00 H	2	37.21	39.45
2	#5725.00	59.41 AV	76.45	-17.04	1.00 H	2	19.96	39.45
3	*5745.00	117.78 PK			1.00 H	2	78.29	39.49
4	*5745.00	106.45 AV			1.00 H	2	66.96	39.49
5	7660.00	50.43 PK	74.00	-23.57	1.00 H	22	5.50	44.93
6	7660.00	39.85 AV	54.00	-14.15	1.00 H	22	-5.08	44.93
7	11490.00	60.57 PK	74.00	-13.43	1.00 H	324	10.61	49.96
8	11490.00	47.86 AV	54.00	-6.14	1.00 H	324	-2.10	49.96
ANTENNA POLARITY & TEST DISTANCE: VERTICAL AT 3 M								
NO.	FREQ. (MHz)	EMISSION LEVEL (dBuV/m)	LIMIT (dBuV/m)	MARGIN (dB)	ANTENNA HEIGHT (m)	TABLE ANGLE (Degree)	RAW VALUE (dBuV)	CORRECTION FACTOR (dB/m)
1	#5725.00	76.37 PK	89.23	-12.86	1.00 V	358	36.92	39.45
2	#5725.00	59.24 AV	78.75	-19.51	1.00 V	358	19.79	39.45
3	*5745.00	119.23 PK			1.00 V	358	79.74	39.49
4	*5745.00	108.75 AV			1.00 V	358	69.26	39.49
5	7660.00	54.24 PK	74.00	-19.76	1.00 V	0	9.31	44.93
6	7660.00	46.00 AV	54.00	-8.00	1.00 V	0	1.07	44.93
7	11490.00	63.25 PK	74.00	-10.75	1.00 V	34	13.29	49.96
8	11490.00	50.47 AV	54.00	-3.53	1.00 V	34	0.51	49.96

- REMARKS:**
1. Emission level (dBuV/m) = Raw Value (dBuV) + Correction Factor (dB/m).
 2. Correction Factor (dB/m) = Antenna Factor (dB/m) + Cable Factor (dB).
 3. The other emission levels were very low against the limit.
 4. Margin value = Emission level – Limit value.
 5. “ * “: Fundamental frequency.
 6. The limit value is defined as per 15.247.
 7. “#”:The radiated frequency is out the restricted band.



A D T

EUT TEST CONDITION		MEASUREMENT DETAIL	
CHANNEL	Channel 157	FREQUENCY RANGE	1 ~ 40GHz
INPUT POWER	120Vac, 60Hz	DETECTOR FUNCTION	Peak (PK) Average (AV)
ENVIRONMENTAL CONDITIONS	28deg. C, 75%RH 1009hPa	TESTED BY	Chad Lee
TEST MODE	A		

ANTENNA POLARITY & TEST DISTANCE: HORIZONTAL AT 3 M								
NO.	FREQ. (MHz)	EMISSION LEVEL (dBuV/m)	LIMIT (dBuV/m)	MARGIN (dB)	ANTENNA HEIGHT (m)	TABLE ANGLE (Degree)	RAW VALUE (dBuV)	CORRECTION FACTOR (dB/m)
1	*5785.00	121.60 PK			1.00 H	0	82.01	39.59
2	*5785.00	111.48 AV			1.00 H	0	71.89	39.59
3	7713.00	52.60 PK	74.00	-21.40	1.00 H	332	7.62	44.98
4	7713.00	42.34 AV	54.00	-11.66	1.00 H	332	-2.64	44.98
5	11570.00	63.48 PK	74.00	-10.52	1.00 H	1	13.58	49.90
6	11570.00	49.57 AV	54.00	-4.43	1.00 H	1	-0.33	49.90
ANTENNA POLARITY & TEST DISTANCE: VERTICAL AT 3 M								
NO.	FREQ. (MHz)	EMISSION LEVEL (dBuV/m)	LIMIT (dBuV/m)	MARGIN (dB)	ANTENNA HEIGHT (m)	TABLE ANGLE (Degree)	RAW VALUE (dBuV)	CORRECTION FACTOR (dB/m)
1	*5785.00	123.24 PK			1.00 V	0	83.65	39.59
2	*5785.00	112.94 AV			1.00 V	0	73.35	39.59
3	7713.00	55.18 PK	74.00	-18.82	1.00 V	5	10.20	44.98
4	7713.00	48.34 AV	54.00	-5.66	1.00 V	5	3.36	44.98
5	11570.00	61.37 PK	74.00	-12.63	1.02 V	330	11.47	49.90
6	11570.00	47.63 AV	54.00	-6.37	1.02 V	330	-2.27	49.90

- REMARKS:**
1. Emission level (dBuV/m) = Raw Value (dBuV) + Correction Factor (dB/m).
 2. Correction Factor (dB/m) = Antenna Factor (dB/m) + Cable Factor (dB).
 3. The other emission levels were very low against the limit.
 4. Margin value = Emission level – Limit value.
 5. “ * “: Fundamental frequency.
 6. The limit value is defined as per 15.247.



A D T

EUT TEST CONDITION		MEASUREMENT DETAIL	
CHANNEL	Channel 165	FREQUENCY RANGE	1 ~ 40GHz
INPUT POWER	120Vac, 60Hz	DETECTOR FUNCTION	Peak (PK) Average (AV)
ENVIRONMENTAL CONDITIONS	28deg. C, 75%RH 1009hPa	TESTED BY	Chad Lee
TEST MODE	A		

ANTENNA POLARITY & TEST DISTANCE: HORIZONTAL AT 3 M								
NO.	FREQ. (MHz)	EMISSION LEVEL (dBuV/m)	LIMIT (dBuV/m)	MARGIN (dB)	ANTENNA HEIGHT (m)	TABLE ANGLE (Degree)	RAW VALUE (dBuV)	CORRECTION FACTOR (dB/m)
1	*5825.00	117.38 PK			1.00 H	5	77.71	39.67
2	*5825.00	107.20 AV			1.00 H	5	67.53	39.67
3	#5850.00	74.16 PK	87.38	-13.22	1.00 H	5	34.43	39.73
4	#5850.00	51.99 AV	77.20	-25.21	1.00 H	5	12.27	39.73
5	#7766.00	53.42 PK	87.38	-33.96	1.00 H	312	8.30	45.12
6	#7766.00	45.28 AV	77.20	-31.92	1.00 H	312	0.16	45.12
7	11650.00	69.12 PK	74.00	-4.88	1.00 H	13	19.32	49.80
8	11650.00	51.77 AV	54.00	-2.23	1.00 H	13	1.97	49.80
ANTENNA POLARITY & TEST DISTANCE: VERTICAL AT 3 M								
NO.	FREQ. (MHz)	EMISSION LEVEL (dBuV/m)	LIMIT (dBuV/m)	MARGIN (dB)	ANTENNA HEIGHT (m)	TABLE ANGLE (Degree)	RAW VALUE (dBuV)	CORRECTION FACTOR (dB/m)
1	*5825.00	119.26 PK			1.00 V	0	79.59	39.67
2	*5825.00	110.46 AV			1.00 V	0	70.79	39.67
3	#5850.00	83.57 PK	89.26	-5.69	1.00 V	0	43.84	39.73
4	#5850.00	54.26 AV	80.46	-26.20	1.00 V	0	14.53	39.73
5	#7766.00	56.12 PK	89.26	-33.14	1.00 V	21	11.00	45.12
6	#7766.00	51.67 AV	80.46	-28.79	1.00 V	21	6.55	45.12
7	11650.00	67.09 PK	74.00	-6.91	1.06 V	324	17.29	49.80
8	11650.00	50.62 AV	54.00	-3.38	1.06 V	324	0.82	49.80

- REMARKS:**
1. Emission level (dBuV/m) = Raw Value (dBuV) + Correction Factor (dB/m).
 2. Correction Factor (dB/m) = Antenna Factor (dB/m) + Cable Factor (dB).
 3. The other emission levels were very low against the limit.
 4. Margin value = Emission level – Limit value.
 5. “ * “: Fundamental frequency.
 6. The limit value is defined as per 15.247.
 7. “#“: The radiated frequency is out the restricted band.



A D T

EUT TEST CONDITION		MEASUREMENT DETAIL	
CHANNEL	Channel 149	FREQUENCY RANGE	1 ~ 40GHz
INPUT POWER	120Vac, 60Hz	DETECTOR FUNCTION	Peak (PK) Average (AV)
ENVIRONMENTAL CONDITIONS	28deg. C, 75%RH 1009hPa	TESTED BY	Chad Lee
TEST MODE	C		

ANTENNA POLARITY & TEST DISTANCE: HORIZONTAL AT 3 M								
NO.	FREQ. (MHz)	EMISSION LEVEL (dBuV/m)	LIMIT (dBuV/m)	MARGIN (dB)	ANTENNA HEIGHT (m)	TABLE ANGLE (Degree)	RAW VALUE (dBuV)	CORRECTION FACTOR (dB/m)
1	#5725.00	75.06 PK	96.72	-21.66	1.14 H	358	35.61	39.45
2	#5725.00	63.71 AV	84.80	-21.09	1.14 H	358	24.26	39.45
3	*5745.00	126.72 PK			1.14 H	358	87.23	39.49
4	*5745.00	114.80 AV			1.14 H	358	75.31	39.49
5	7660.00	54.81 PK	74.00	-19.19	1.19 H	24	9.88	44.93
6	7660.00	42.49 AV	54.00	-11.51	1.19 H	24	-2.44	44.93
7	11490.00	60.90 PK	74.00	-13.10	1.05 H	224	10.94	49.96
8	11490.00	47.13 AV	54.00	-6.87	1.05 H	224	-2.83	49.96
ANTENNA POLARITY & TEST DISTANCE: VERTICAL AT 3 M								
NO.	FREQ. (MHz)	EMISSION LEVEL (dBuV/m)	LIMIT (dBuV/m)	MARGIN (dB)	ANTENNA HEIGHT (m)	TABLE ANGLE (Degree)	RAW VALUE (dBuV)	CORRECTION FACTOR (dB/m)
1	#5725.00	85.10 PK	94.51	-9.41	1.13 V	0	45.65	39.45
2	#5725.00	63.21 AV	82.09	-18.88	1.13 V	0	23.76	39.45
3	*5745.00	124.51 PK			1.13 V	0	85.02	39.49
4	*5745.00	112.09 AV			1.13 V	0	72.60	39.49
5	7660.00	53.52 PK	74.00	-20.48	1.06 V	148	8.59	44.93
6	7660.00	39.68 AV	54.00	-14.32	1.06 V	148	-5.25	44.93
7	11490.00	67.92 PK	74.00	-6.08	1.13 V	98	17.96	49.96
8	11490.00	52.67 AV	54.00	-1.33	1.13 V	98	2.71	49.96

- REMARKS:**
1. Emission level (dBuV/m) = Raw Value (dBuV) + Correction Factor (dB/m).
 2. Correction Factor (dB/m) = Antenna Factor (dB/m) + Cable Factor (dB).
 3. The other emission levels were very low against the limit.
 4. Margin value = Emission level – Limit value.
 5. “ * “: Fundamental frequency.
 6. The limit value is defined as per 15.247.
 7. "#":The radiated frequency is out the restricted band.



A D T

EUT TEST CONDITION		MEASUREMENT DETAIL	
CHANNEL	Channel 157	FREQUENCY RANGE	1 ~ 40GHz
INPUT POWER	120Vac, 60Hz	DETECTOR FUNCTION	Peak (PK) Average (AV)
ENVIRONMENTAL CONDITIONS	28deg. C, 75%RH 1009hPa	TESTED BY	Chad Lee
TEST MODE	C		

ANTENNA POLARITY & TEST DISTANCE: HORIZONTAL AT 3 M								
NO.	FREQ. (MHz)	EMISSION LEVEL (dBuV/m)	LIMIT (dBuV/m)	MARGIN (dB)	ANTENNA HEIGHT (m)	TABLE ANGLE (Degree)	RAW VALUE (dBuV)	CORRECTION FACTOR (dB/m)
1	*5785.00	127.10 PK			1.05 H	358	87.51	39.59
2	*5785.00	115.16 AV			1.05 H	358	75.57	39.59
3	7713.00	57.02 PK	74.00	-16.98	1.10 H	30	12.04	44.98
4	7713.00	48.48 AV	54.00	-5.52	1.10 H	30	3.50	44.98
5	11570.00	63.04 PK	74.00	-10.96	1.17 H	109	13.14	49.90
6	11570.00	49.01 AV	54.00	-4.99	1.17 H	109	-0.89	49.90
ANTENNA POLARITY & TEST DISTANCE: VERTICAL AT 3 M								
NO.	FREQ. (MHz)	EMISSION LEVEL (dBuV/m)	LIMIT (dBuV/m)	MARGIN (dB)	ANTENNA HEIGHT (m)	TABLE ANGLE (Degree)	RAW VALUE (dBuV)	CORRECTION FACTOR (dB/m)
1	*5785.00	125.52 PK			1.08 V	1	85.93	39.59
2	*5785.00	112.61 AV			1.08 V	1	73.02	39.59
3	7713.00	53.81 PK	74.00	-20.19	1.27 V	80	8.83	44.98
4	7713.00	39.47 AV	54.00	-14.53	1.27 V	80	-5.51	44.98
5	11570.00	67.03 PK	74.00	-6.97	1.00 V	262	17.13	49.90
6	11570.00	52.82 AV	54.00	-1.18	1.00 V	262	2.92	49.90

- REMARKS:**
1. Emission level (dBuV/m) = Raw Value (dBuV) + Correction Factor (dB/m).
 2. Correction Factor (dB/m) = Antenna Factor (dB/m) + Cable Factor (dB).
 3. The other emission levels were very low against the limit.
 4. Margin value = Emission level – Limit value.
 5. “ * “: Fundamental frequency.
 6. The limit value is defined as per 15.247.



A D T

EUT TEST CONDITION		MEASUREMENT DETAIL	
CHANNEL	Channel 165	FREQUENCY RANGE	1 ~ 40GHz
INPUT POWER	120Vac, 60Hz	DETECTOR FUNCTION	Peak (PK) Average (AV)
ENVIRONMENTAL CONDITIONS	28deg. C, 75%RH 1009hPa	TESTED BY	Chad Lee
TEST MODE	C		

ANTENNA POLARITY & TEST DISTANCE: HORIZONTAL AT 3 M								
NO.	FREQ. (MHz)	EMISSION LEVEL (dBuV/m)	LIMIT (dBuV/m)	MARGIN (dB)	ANTENNA HEIGHT (m)	TABLE ANGLE (Degree)	RAW VALUE (dBuV)	CORRECTION FACTOR (dB/m)
1	*5825.00	125.74 PK			1.00 H	358	86.07	39.67
2	*5825.00	114.39 AV			1.00 H	358	74.72	39.67
3	#5850.00	75.48 PK	95.74	-20.26	1.00 H	358	35.76	39.73
4	#5850.00	54.71 AV	84.39	-29.68	1.00 H	358	14.98	39.73
5	#7766.00	58.49 PK	95.74	-37.25	1.00 H	333	13.37	45.12
6	#7766.00	48.08 AV	84.39	-36.31	1.00 H	333	2.96	45.12
7	11650.00	61.02 PK	74.00	-12.98	1.21 H	208	11.22	49.80
8	11650.00	46.03 AV	54.00	-7.97	1.21 H	208	-3.77	49.80
ANTENNA POLARITY & TEST DISTANCE: VERTICAL AT 3 M								
NO.	FREQ. (MHz)	EMISSION LEVEL (dBuV/m)	LIMIT (dBuV/m)	MARGIN (dB)	ANTENNA HEIGHT (m)	TABLE ANGLE (Degree)	RAW VALUE (dBuV)	CORRECTION FACTOR (dB/m)
1	*5825.00	124.75 PK			1.00 V	355	85.08	39.67
2	*5825.00	114.26 AV			1.00 V	355	74.59	39.67
3	#5850.00	75.31 PK	94.75	-19.44	1.00 V	355	35.59	39.73
4	#5850.00	54.12 AV	84.26	-30.14	1.00 V	355	14.39	39.73
5	#7766.00	56.02 PK	94.75	-38.73	1.00 V	358	10.90	45.12
6	#7766.00	46.12 AV	84.26	-38.14	1.00 V	358	1.00	45.12
7	11650.00	66.76 PK	74.00	-7.24	1.00 V	85	16.96	49.80
8	11650.00	52.61 AV	54.00	-1.39	1.00 V	85	2.81	49.80

- REMARKS:**
1. Emission level (dBuV/m) = Raw Value (dBuV) + Correction Factor (dB/m).
 2. Correction Factor (dB/m) = Antenna Factor (dB/m) + Cable Factor (dB).
 3. The other emission levels were very low against the limit.
 4. Margin value = Emission level – Limit value.
 5. “ * “: Fundamental frequency.
 6. The limit value is defined as per 15.247.
 7. “#“: The radiated frequency is out the restricted band.



A D T

DRAFT 802.11n (20MHz) OFDM MODULATION

EUT TEST CONDITION		MEASUREMENT DETAIL	
CHANNEL	Channel 149	FREQUENCY RANGE	1 ~ 40GHz
INPUT POWER	120Vac, 60Hz	DETECTOR FUNCTION	Peak (PK) Average (AV)
ENVIRONMENTAL CONDITIONS	28deg. C, 75%RH 1009hPa	TESTED BY	Chad Lee
TEST MODE	A		

ANTENNA POLARITY & TEST DISTANCE: HORIZONTAL AT 3 M

NO.	FREQ. (MHz)	EMISSION LEVEL (dBuV/m)	LIMIT (dBuV/m)	MARGIN (dB)	ANTENNA HEIGHT (m)	TABLE ANGLE (Degree)	RAW VALUE (dBuV)	CORRECTION FACTOR (dB/m)
1	#5725.00	77.77 PK	88.92	-11.15	1.00 H	2	38.32	39.45
2	#5725.00	60.53 AV	77.66	-17.13	1.00 H	2	21.08	39.45
3	*5745.00	118.92 PK			1.00 H	359	79.43	39.49
4	*5745.00	107.66 AV			1.00 H	359	68.17	39.49
5	7660.00	51.54 PK	74.00	-22.46	1.00 H	20	6.62	44.93
6	7660.00	40.97 AV	54.00	-13.03	1.00 H	20	-3.95	44.93
7	11490.00	61.68 PK	74.00	-12.32	1.00 H	324	11.72	49.96
8	11490.00	48.98 AV	54.00	-5.02	1.00 H	324	-0.98	49.96

ANTENNA POLARITY & TEST DISTANCE: VERTICAL AT 3 M

NO.	FREQ. (MHz)	EMISSION LEVEL (dBuV/m)	LIMIT (dBuV/m)	MARGIN (dB)	ANTENNA HEIGHT (m)	TABLE ANGLE (Degree)	RAW VALUE (dBuV)	CORRECTION FACTOR (dB/m)
1	#5725.00	77.48 PK	90.48	-13.00	1.00 V	356	38.03	39.45
2	#5725.00	60.35 AV	79.98	-19.63	1.00 V	356	20.90	39.45
3	*5745.00	120.48 PK			1.00 V	358	80.99	39.49
4	*5745.00	109.98 AV			1.00 V	358	70.49	39.49
5	7660.00	55.36 PK	74.00	-18.64	1.00 V	0	10.44	44.93
6	7660.00	47.11 AV	54.00	-6.89	1.00 V	0	2.19	44.93
7	11490.00	64.36 PK	74.00	-9.64	1.00 V	37	14.40	49.96
8	11490.00	51.58 AV	54.00	-2.42	1.00 V	37	1.62	49.96

- REMARKS:**
1. Emission level (dBuV/m) = Raw Value (dBuV) + Correction Factor (dB/m).
 2. Correction Factor (dB/m) = Antenna Factor (dB/m) + Cable Factor (dB).
 3. The other emission levels were very low against the limit.
 4. Margin value = Emission level – Limit value.
 5. “ * “: Fundamental frequency.
 6. The limit value is defined as per 15.247.
 7. “#“: The radiated frequency is out the restricted band.



A D T

EUT TEST CONDITION		MEASUREMENT DETAIL	
CHANNEL	Channel 157	FREQUENCY RANGE	1 ~ 40GHz
INPUT POWER	120Vac, 60Hz	DETECTOR FUNCTION	Peak (PK) Average (AV)
ENVIRONMENTAL CONDITIONS	28deg. C, 75%RH 1009hPa	TESTED BY	Chad Lee
TEST MODE	A		

ANTENNA POLARITY & TEST DISTANCE: HORIZONTAL AT 3 M								
NO.	FREQ. (MHz)	EMISSION LEVEL (dBuV/m)	LIMIT (dBuV/m)	MARGIN (dB)	ANTENNA HEIGHT (m)	TABLE ANGLE (Degree)	RAW VALUE (dBuV)	CORRECTION FACTOR (dB/m)
1	*5785.00	122.80 PK			1.00 H	1	83.21	39.59
2	*5785.00	112.50 AV			1.00 H	1	72.91	39.59
3	7713.00	53.80 PK	74.00	-20.20	1.00 H	334	8.82	44.98
4	7713.00	43.46 AV	54.00	-10.54	1.00 H	334	-1.52	44.98
5	11570.00	64.88 PK	74.00	-9.12	1.00 H	2	14.98	49.90
6	11570.00	50.87 AV	54.00	-3.12	1.00 H	2	0.97	49.90
ANTENNA POLARITY & TEST DISTANCE: VERTICAL AT 3 M								
NO.	FREQ. (MHz)	EMISSION LEVEL (dBuV/m)	LIMIT (dBuV/m)	MARGIN (dB)	ANTENNA HEIGHT (m)	TABLE ANGLE (Degree)	RAW VALUE (dBuV)	CORRECTION FACTOR (dB/m)
1	*5785.00	124.14 PK			1.00 V	1	84.55	39.59
2	*5785.00	114.04 AV			1.00 V	1	74.45	39.59
3	7713.00	56.22 PK	74.00	-17.78	1.00 V	8	11.24	44.98
4	7713.00	49.44 AV	54.00	-4.56	1.00 V	8	4.46	44.98
5	11570.00	63.48 PK	74.00	-10.52	1.02 V	331	13.58	49.90
6	11570.00	49.83 AV	54.00	-4.17	1.02 V	331	-0.08	49.90

- REMARKS:**
1. Emission level (dBuV/m) = Raw Value (dBuV) + Correction Factor (dB/m).
 2. Correction Factor (dB/m) = Antenna Factor (dB/m) + Cable Factor (dB).
 3. The other emission levels were very low against the limit.
 4. Margin value = Emission level – Limit value.
 5. “ * ”: Fundamental frequency.
 6. The limit value is defined as per 15.247.



A D T

EUT TEST CONDITION		MEASUREMENT DETAIL	
CHANNEL	Channel 165	FREQUENCY RANGE	1 ~ 40GHz
INPUT POWER	120Vac, 60Hz	DETECTOR FUNCTION	Peak (PK) Average (AV)
ENVIRONMENTAL CONDITIONS	28deg. C, 75%RH 1009hPa	TESTED BY	Chad Lee
TEST MODE	A		

ANTENNA POLARITY & TEST DISTANCE: HORIZONTAL AT 3 M								
NO.	FREQ. (MHz)	EMISSION LEVEL (dBuV/m)	LIMIT (dBuV/m)	MARGIN (dB)	ANTENNA HEIGHT (m)	TABLE ANGLE (Degree)	RAW VALUE (dBuV)	CORRECTION FACTOR (dB/m)
1	*5825.00	118.49 PK			1.00 H	2	78.82	39.67
2	*5825.00	108.31 AV			1.00 H	2	68.64	39.67
3	#5850.00	75.28 PK	88.49	-13.21	1.00 H	2	35.55	39.73
4	#5850.00	53.02 AV	78.31	-25.29	1.00 H	2	13.29	39.73
5	#7766.00	54.53 PK	88.49	-33.96	1.00 H	314	9.41	45.12
6	#7766.00	46.39 AV	78.31	-31.92	1.00 H	314	1.27	45.12
7	11650.00	70.26 PK	74.00	-3.74	1.00 H	16	20.46	49.80
8	11650.00	52.85 AV	54.00	-1.15	1.00 H	16	3.05	49.80
ANTENNA POLARITY & TEST DISTANCE: VERTICAL AT 3 M								
NO.	FREQ. (MHz)	EMISSION LEVEL (dBuV/m)	LIMIT (dBuV/m)	MARGIN (dB)	ANTENNA HEIGHT (m)	TABLE ANGLE (Degree)	RAW VALUE (dBuV)	CORRECTION FACTOR (dB/m)
1	*5825.00	120.58 PK			1.00 V	1	80.91	39.67
2	*5825.00	110.59 AV			1.00 V	1	70.92	39.67
3	#5850.00	84.69 PK	90.58	-5.89	1.00 V	1	44.96	39.73
4	#5850.00	55.46 AV	80.59	-25.13	1.00 V	1	15.73	39.73
5	#7766.00	57.25 PK	90.58	-33.33	1.00 V	19	12.13	45.12
6	#7766.00	52.73 AV	80.59	-27.86	1.00 V	19	7.61	45.12
7	11650.00	68.20 PK	74.00	-5.80	1.06 V	326	18.40	49.80
8	11650.00	51.73 AV	54.00	-2.27	1.06 V	326	1.93	49.80

- REMARKS:**
1. Emission level (dBuV/m) = Raw Value (dBuV) + Correction Factor (dB/m).
 2. Correction Factor (dB/m) = Antenna Factor (dB/m) + Cable Factor (dB).
 3. The other emission levels were very low against the limit.
 4. Margin value = Emission level – Limit value.
 5. “ * “: Fundamental frequency.
 6. The limit value is defined as per 15.247.
 7. “#“: The radiated frequency is out the restricted band.



A D T

EUT TEST CONDITION		MEASUREMENT DETAIL	
CHANNEL	Channel 149	FREQUENCY RANGE	1 ~ 40GHz
INPUT POWER	120Vac, 60Hz	DETECTOR FUNCTION	Peak (PK) Average (AV)
ENVIRONMENTAL CONDITIONS	28deg. C, 75%RH 1009hPa	TESTED BY	Chad Lee
TEST MODE	C		

ANTENNA POLARITY & TEST DISTANCE: HORIZONTAL AT 3 M								
NO.	FREQ. (MHz)	EMISSION LEVEL (dBuV/m)	LIMIT (dBuV/m)	MARGIN (dB)	ANTENNA HEIGHT (m)	TABLE ANGLE (Degree)	RAW VALUE (dBuV)	CORRECTION FACTOR (dB/m)
1	#5725.00	86.11 PK	97.95	-11.84	1.15 H	357	46.66	39.45
2	#5725.00	64.88 AV	85.93	-21.05	1.15 H	357	25.43	39.45
3	*5745.00	127.95 PK			1.15 H	357	88.46	39.49
4	*5745.00	115.93 AV			1.15 H	357	76.44	39.49
5	7660.00	55.99 PK	74.00	-18.01	1.18 H	25	11.07	44.93
6	7660.00	43.64 AV	54.00	-10.36	1.18 H	25	-1.28	44.93
7	11490.00	62.03 PK	74.00	-11.97	1.06 H	223	12.07	49.96
8	11490.00	48.34 AV	54.00	-5.66	1.06 H	223	-1.62	49.96
ANTENNA POLARITY & TEST DISTANCE: VERTICAL AT 3 M								
NO.	FREQ. (MHz)	EMISSION LEVEL (dBuV/m)	LIMIT (dBuV/m)	MARGIN (dB)	ANTENNA HEIGHT (m)	TABLE ANGLE (Degree)	RAW VALUE (dBuV)	CORRECTION FACTOR (dB/m)
1	#5725.00	86.22 PK	95.64	-9.42	1.14 V	0	46.77	39.45
2	#5725.00	64.69 AV	83.24	-18.55	1.14 V	0	25.24	39.45
3	*5745.00	125.64 PK			1.14 V	0	86.15	39.49
4	*5745.00	113.24 AV			1.14 V	0	73.75	39.49
5	7660.00	54.76 PK	74.00	-19.24	1.06 V	147	9.84	44.93
6	7660.00	40.85 AV	54.00	-13.15	1.06 V	147	-4.07	44.93
7	11490.00	69.01 PK	74.00	-4.99	1.14 V	100	19.05	49.96
8	11490.00	53.88 AV	54.00	-0.12	1.14 V	100	3.92	49.96

- REMARKS:**
1. Emission level (dBuV/m) = Raw Value (dBuV) + Correction Factor (dB/m).
 2. Correction Factor (dB/m) = Antenna Factor (dB/m) + Cable Factor (dB).
 3. The other emission levels were very low against the limit.
 4. Margin value = Emission level – Limit value.
 5. “ * “: Fundamental frequency.
 6. The limit value is defined as per 15.247.
 7. "#":The radiated frequency is out the restricted band.



A D T

EUT TEST CONDITION		MEASUREMENT DETAIL	
CHANNEL	Channel 157	FREQUENCY RANGE	1 ~ 40GHz
INPUT POWER	120Vac, 60Hz	DETECTOR FUNCTION	Peak (PK) Average (AV)
ENVIRONMENTAL CONDITIONS	28deg. C, 75%RH 1009hPa	TESTED BY	Chad Lee
TEST MODE	C		

ANTENNA POLARITY & TEST DISTANCE: HORIZONTAL AT 3 M								
NO.	FREQ. (MHz)	EMISSION LEVEL (dBuV/m)	LIMIT (dBuV/m)	MARGIN (dB)	ANTENNA HEIGHT (m)	TABLE ANGLE (Degree)	RAW VALUE (dBuV)	CORRECTION FACTOR (dB/m)
1	*5785.00	128.22 PK			1.06 H	357	88.63	39.59
2	*5785.00	116.37 AV			1.06 H	357	76.78	39.59
3	7713.00	58.17 PK	74.00	-15.83	1.11 H	29	13.19	44.98
4	7713.00	49.66 AV	54.00	-4.34	1.11 H	29	4.68	44.98
5	11570.00	64.29 PK	74.00	-9.71	1.18 H	107	14.39	49.90
6	11570.00	50.05 AV	54.00	-3.95	1.18 H	107	0.15	49.90
ANTENNA POLARITY & TEST DISTANCE: VERTICAL AT 3 M								
NO.	FREQ. (MHz)	EMISSION LEVEL (dBuV/m)	LIMIT (dBuV/m)	MARGIN (dB)	ANTENNA HEIGHT (m)	TABLE ANGLE (Degree)	RAW VALUE (dBuV)	CORRECTION FACTOR (dB/m)
1	*5785.00	126.76 PK			1.07 V	0	87.17	39.59
2	*5785.00	113.78 AV			1.07 V	0	74.19	39.59
3	7713.00	54.98 PK	74.00	-19.02	1.28 V	78	10.00	44.98
4	7713.00	40.61 AV	54.00	-13.39	1.28 V	78	-4.37	44.98
5	11570.00	68.21 PK	74.00	-5.79	1.00 V	261	18.31	49.90
6	11570.00	53.96 AV	54.00	-0.04	1.00 V	261	4.06	49.90

- REMARKS:**
1. Emission level (dBuV/m) = Raw Value (dBuV) + Correction Factor (dB/m).
 2. Correction Factor (dB/m) = Antenna Factor (dB/m) + Cable Factor (dB).
 3. The other emission levels were very low against the limit.
 4. Margin value = Emission level – Limit value.
 5. “ * ”: Fundamental frequency.
 6. The limit value is defined as per 15.247.



A D T

EUT TEST CONDITION		MEASUREMENT DETAIL	
CHANNEL	Channel 165	FREQUENCY RANGE	1 ~ 40GHz
INPUT POWER	120Vac, 60Hz	DETECTOR FUNCTION	Peak (PK) Average (AV)
ENVIRONMENTAL CONDITIONS	28deg. C, 75%RH 1009hPa	TESTED BY	Chad Lee
TEST MODE	C		

ANTENNA POLARITY & TEST DISTANCE: HORIZONTAL AT 3 M								
NO.	FREQ. (MHz)	EMISSION LEVEL (dBuV/m)	LIMIT (dBuV/m)	MARGIN (dB)	ANTENNA HEIGHT (m)	TABLE ANGLE (Degree)	RAW VALUE (dBuV)	CORRECTION FACTOR (dB/m)
1	*5825.00	126.90 PK			1.00 H	355	87.23	39.67
2	*5825.00	115.50 AV			1.00 H	355	75.83	39.67
3	#5850.00	76.68 PK	96.90	-20.22	1.00 H	357	36.96	39.73
4	#5850.00	55.82 AV	85.50	-29.68	1.00 H	357	16.09	39.73
5	#7766.00	59.68 PK	96.90	-37.22	1.00 H	331	14.56	45.12
6	#7766.00	49.22 AV	85.50	-36.28	1.00 H	331	4.10	45.12
7	11650.00	62.20 PK	74.00	-11.80	1.22 H	205	12.40	49.80
8	11650.00	47.16 AV	54.00	-6.84	1.22 H	205	-2.64	49.80
ANTENNA POLARITY & TEST DISTANCE: VERTICAL AT 3 M								
NO.	FREQ. (MHz)	EMISSION LEVEL (dBuV/m)	LIMIT (dBuV/m)	MARGIN (dB)	ANTENNA HEIGHT (m)	TABLE ANGLE (Degree)	RAW VALUE (dBuV)	CORRECTION FACTOR (dB/m)
1	*5825.00	125.90 PK			1.00 V	354	86.23	39.67
2	*5825.00	115.43 AV			1.00 V	354	75.76	39.67
3	#5850.00	76.48 PK	95.90	-19.42	1.00 V	354	36.76	39.73
4	#5850.00	55.37 AV	85.43	-30.06	1.00 V	354	15.64	39.73
5	#7766.00	57.11 PK	95.90	-38.79	1.00 V	357	11.99	45.12
6	#7766.00	47.26 AV	85.43	-38.17	1.00 V	357	2.14	45.12
7	11650.00	67.92 PK	74.00	-6.08	1.00 V	83	18.12	49.80
8	11650.00	53.79 AV	54.00	-0.21	1.00 V	83	3.99	49.80

- REMARKS:**
1. Emission level (dBuV/m) = Raw Value (dBuV) + Correction Factor (dB/m).
 2. Correction Factor (dB/m) = Antenna Factor (dB/m) + Cable Factor (dB).
 3. The other emission levels were very low against the limit.
 4. Margin value = Emission level – Limit value.
 5. “ * “: Fundamental frequency.
 6. The limit value is defined as per 15.247.
 7. “#“: The radiated frequency is out the restricted band.



A D T

DRAFT 802.11n (40MHz) OFDM MODULATION

EUT TEST CONDITION		MEASUREMENT DETAIL	
CHANNEL	Channel 151	FREQUENCY RANGE	1 ~ 40GHz
INPUT POWER	120Vac, 60Hz	DETECTOR FUNCTION	Peak (PK) Average (AV)
ENVIRONMENTAL CONDITIONS	28deg. C, 75%RH 1009hPa	TESTED BY	Chad Lee
TEST MODE	A		

ANTENNA POLARITY & TEST DISTANCE: HORIZONTAL AT 3 M

NO.	FREQ. (MHz)	EMISSION LEVEL (dBuV/m)	LIMIT (dBuV/m)	MARGIN (dB)	ANTENNA HEIGHT (m)	TABLE ANGLE (Degree)	RAW VALUE (dBuV)	CORRECTION FACTOR (dB/m)
1	#5725.00	75.62 PK	83.64	-8.02	1.00 H	1	36.17	39.45
2	#5725.00	53.31 AV	73.15	-19.84	1.00 H	1	13.86	39.45
3	*5755.00	113.64 PK			1.00 H	1	74.12	39.52
4	*5755.00	103.15 AV			1.00 H	1	63.63	39.52
5	7673.00	53.54 PK	74.00	-20.46	1.00 H	341	8.61	44.93
6	7673.00	42.62 AV	54.00	-11.38	1.00 H	341	-2.31	44.93
7	11510.00	62.70 PK	74.00	-11.30	1.00 H	301	12.76	49.94
8	11510.00	49.48 AV	54.00	-4.52	1.00 H	301	-0.47	49.94

ANTENNA POLARITY & TEST DISTANCE: VERTICAL AT 3 M

NO.	FREQ. (MHz)	EMISSION LEVEL (dBuV/m)	LIMIT (dBuV/m)	MARGIN (dB)	ANTENNA HEIGHT (m)	TABLE ANGLE (Degree)	RAW VALUE (dBuV)	CORRECTION FACTOR (dB/m)
1	#5725.00	77.49 PK	86.40	-8.91	1.00 V	0	38.04	39.45
2	#5725.00	51.13 AV	76.50	-25.37	1.00 V	0	11.68	39.45
3	*5755.00	116.40 PK			1.00 V	0	76.88	39.52
4	*5755.00	106.50 AV			1.00 V	0	66.98	39.52
5	7673.00	55.00 PK	74.00	-19.00	1.00 V	6	10.07	44.93
6	7673.00	46.92 AV	54.00	-7.08	1.00 V	6	1.99	44.93
7	11510.00	58.76 PK	74.00	-15.24	1.00 V	19	8.81	49.94
8	11510.00	47.04 AV	54.00	-6.96	1.00 V	19	-2.91	49.94

- REMARKS:**
1. Emission level (dBuV/m) = Raw Value (dBuV) + Correction Factor (dB/m).
 2. Correction Factor (dB/m) = Antenna Factor (dB/m) + Cable Factor (dB).
 3. The other emission levels were very low against the limit.
 4. Margin value = Emission level – Limit value.
 5. “ * “: Fundamental frequency.
 6. The limit value is defined as per 15.247.
 7. “#”:The radiated frequency is out the restricted band.



A D T

EUT TEST CONDITION		MEASUREMENT DETAIL	
CHANNEL	Channel 159	FREQUENCY RANGE	1 ~ 40GHz
INPUT POWER	120Vac, 60Hz	DETECTOR FUNCTION	Peak (PK) Average (AV)
ENVIRONMENTAL CONDITIONS	28deg. C, 75%RH 1009hPa	TESTED BY	Chad Lee
TEST MODE	A		

ANTENNA POLARITY & TEST DISTANCE: HORIZONTAL AT 3 M								
NO.	FREQ. (MHz)	EMISSION LEVEL (dBuV/m)	LIMIT (dBuV/m)	MARGIN (dB)	ANTENNA HEIGHT (m)	TABLE ANGLE (Degree)	RAW VALUE (dBuV)	CORRECTION FACTOR (dB/m)
1	*5795.00	114.20 PK			1.03 H	2	74.59	39.61
2	*5795.00	103.54 AV			1.03 H	2	63.93	39.61
3	#5850.00	67.03 PK	84.20	-17.17	1.03 H	2	27.31	39.73
4	#5850.00	49.97 AV	73.54	-23.57	1.03 H	2	10.24	39.73
5	7726.00	55.63 PK	74.00	-18.37	1.00 H	339	10.61	45.02
6	7726.00	44.18 AV	54.00	-9.82	1.00 H	339	-0.84	45.02
7	11590.00	62.90 PK	74.00	-11.10	1.00 H	300	13.01	49.89
8	11590.00	50.41 AV	54.00	-3.59	1.00 H	300	0.52	49.89
ANTENNA POLARITY & TEST DISTANCE: VERTICAL AT 3 M								
NO.	FREQ. (MHz)	EMISSION LEVEL (dBuV/m)	LIMIT (dBuV/m)	MARGIN (dB)	ANTENNA HEIGHT (m)	TABLE ANGLE (Degree)	RAW VALUE (dBuV)	CORRECTION FACTOR (dB/m)
1	*5795.00	117.16 PK			1.00 V	2	77.55	39.61
2	*5795.00	106.81 AV			1.00 V	2	67.20	39.61
3	#5850.00	66.49 PK	87.16	-20.67	1.00 V	2	26.76	39.73
4	#5850.00	48.77 AV	76.81	-28.04	1.00 V	2	9.04	39.73
5	7726.00	57.96 PK	74.00	-16.04	1.00 V	5	12.94	45.02
6	7726.00	48.63 AV	54.00	-5.37	1.00 V	5	3.61	45.02
7	11590.00	59.73 PK	74.00	-14.27	1.00 V	33	9.85	49.89
8	11590.00	46.62 AV	54.00	-7.37	1.00 V	33	-3.26	49.89

- REMARKS:**
1. Emission level (dBuV/m) = Raw Value (dBuV) + Correction Factor (dB/m).
 2. Correction Factor (dB/m) = Antenna Factor (dB/m) + Cable Factor (dB).
 3. The other emission levels were very low against the limit.
 4. Margin value = Emission level – Limit value.
 5. “ * “: Fundamental frequency.
 6. The limit value is defined as per 15.247.
 7. “#“: The radiated frequency is out the restricted band.



A D T

EUT TEST CONDITION		MEASUREMENT DETAIL	
CHANNEL	Channel 151	FREQUENCY RANGE	1 ~ 40GHz
INPUT POWER	120Vac, 60Hz	DETECTOR FUNCTION	Peak (PK) Average (AV)
ENVIRONMENTAL CONDITIONS	28deg. C, 75%RH 1009hPa	TESTED BY	Chad Lee
TEST MODE	C		

ANTENNA POLARITY & TEST DISTANCE: HORIZONTAL AT 3 M								
NO.	FREQ. (MHz)	EMISSION LEVEL (dBuV/m)	LIMIT (dBuV/m)	MARGIN (dB)	ANTENNA HEIGHT (m)	TABLE ANGLE (Degree)	RAW VALUE (dBuV)	CORRECTION FACTOR (dB/m)
1	#5725.00	94.70 PK	94.80	-0.10	1.13 H	358	55.25	39.45
2	#5725.00	67.80 AV	81.78	-13.98	1.13 H	358	28.35	39.45
3	*5755.00	124.80 PK			1.13 H	358	85.28	39.52
4	*5755.00	111.78 AV			1.13 H	358	72.26	39.52
5	7674.00	55.58 PK	74.00	-18.42	1.14 H	28	10.65	44.93
6	7674.00	46.46 AV	54.00	-7.54	1.14 H	28	1.53	44.93
7	11510.00	60.71 PK	74.00	-13.29	1.12 H	266	10.77	49.94
8	11510.00	46.56 AV	54.00	-7.44	1.12 H	266	-3.38	49.94
ANTENNA POLARITY & TEST DISTANCE: VERTICAL AT 3 M								
NO.	FREQ. (MHz)	EMISSION LEVEL (dBuV/m)	LIMIT (dBuV/m)	MARGIN (dB)	ANTENNA HEIGHT (m)	TABLE ANGLE (Degree)	RAW VALUE (dBuV)	CORRECTION FACTOR (dB/m)
1	#5725.00	92.17 PK	92.50	-0.33	1.08 V	357	52.72	39.45
2	#5725.00	67.70 AV	79.64	-11.94	1.08 V	357	28.25	39.45
3	*5755.00	122.50 PK			1.08 V	357	82.98	39.52
4	*5755.00	109.64 AV			1.08 V	357	70.12	39.52
5	7674.00	53.59 PK	74.00	-20.41	1.12 V	359	8.66	44.93
6	7674.00	41.02 AV	54.00	-12.98	1.12 V	359	-3.91	44.93
7	11510.00	65.17 PK	74.00	-8.83	1.12 V	100	15.23	49.94
8	11510.00	51.30 AV	54.00	-2.70	1.12 V	100	1.36	49.94

- REMARKS:**
1. Emission level (dBuV/m) = Raw Value (dBuV) + Correction Factor (dB/m).
 2. Correction Factor (dB/m) = Antenna Factor (dB/m) + Cable Factor (dB).
 3. The other emission levels were very low against the limit.
 4. Margin value = Emission level – Limit value.
 5. “ * “: Fundamental frequency.
 6. The limit value is defined as per 15.247.
 7. "#":The radiated frequency is out the restricted band.



A D T

EUT TEST CONDITION		MEASUREMENT DETAIL	
CHANNEL	Channel 159	FREQUENCY RANGE	1 ~ 40GHz
INPUT POWER	120Vac, 60Hz	DETECTOR FUNCTION	Peak (PK) Average (AV)
ENVIRONMENTAL CONDITIONS	28deg. C, 75%RH 1009hPa	TESTED BY	Chad Lee
TEST MODE	C		

ANTENNA POLARITY & TEST DISTANCE: HORIZONTAL AT 3 M								
NO.	FREQ. (MHz)	EMISSION LEVEL (dBuV/m)	LIMIT (dBuV/m)	MARGIN (dB)	ANTENNA HEIGHT (m)	TABLE ANGLE (Degree)	RAW VALUE (dBuV)	CORRECTION FACTOR (dB/m)
1	*5795.00	123.13 PK			1.18 H	358	83.52	39.61
2	*5795.00	110.22 AV			1.18 H	358	70.61	39.61
3	#5850.00	92.89 PK	93.13	-0.24	1.18 H	358	53.16	39.73
4	#5850.00	66.36 AV	80.22	-13.86	1.18 H	358	26.63	39.73
5	7726.00	54.94 PK	74.00	-19.06	1.12 H	69	9.92	45.02
6	7726.00	46.40 AV	54.00	-7.60	1.12 H	69	1.38	45.02
7	11590.00	60.06 PK	74.00	-13.94	1.15 H	239	10.17	49.89
8	11590.00	45.89 AV	54.00	-8.11	1.15 H	239	-4.00	49.89
ANTENNA POLARITY & TEST DISTANCE: VERTICAL AT 3 M								
NO.	FREQ. (MHz)	EMISSION LEVEL (dBuV/m)	LIMIT (dBuV/m)	MARGIN (dB)	ANTENNA HEIGHT (m)	TABLE ANGLE (Degree)	RAW VALUE (dBuV)	CORRECTION FACTOR (dB/m)
1	*5795.00	120.32 PK			1.15 V	359	80.71	39.61
2	*5795.00	107.60 AV			1.15 V	359	67.99	39.61
3	#5850.00	90.23 PK	90.32	-0.09	1.15 V	359	50.51	39.73
4	#5850.00	63.44 AV	77.60	-14.16	1.15 V	359	23.71	39.73
5	7726.00	52.33 PK	74.00	-21.67	1.00 V	241	7.31	45.02
6	7726.00	38.43 AV	54.00	-15.57	1.00 V	241	-6.59	45.02
7	11590.00	64.96 PK	74.00	-9.04	1.00 V	103	15.07	49.89
8	11590.00	50.61 AV	54.00	-3.39	1.00 V	103	0.72	49.89

- REMARKS:**
1. Emission level (dBuV/m) = Raw Value (dBuV) + Correction Factor (dB/m).
 2. Correction Factor (dB/m) = Antenna Factor (dB/m) + Cable Factor (dB).
 3. The other emission levels were very low against the limit.
 4. Margin value = Emission level – Limit value.
 5. “ * “: Fundamental frequency.
 6. The limit value is defined as per 15.247.
 7. “#“: The radiated frequency is out the restricted band.



A D T

BELOW 1GHz WORST-CASE DATA : Draft 802.11n (20MHz) OFDM MODULATION

EUT TEST CONDITION		MEASUREMENT DETAIL	
CHANNEL	Channel 157	FREQUENCY RANGE	Below 1000MHz
INPUT POWER	120Vac, 60Hz	DETECTOR FUNCTION	Quasi-Peak
ENVIRONMENTAL CONDITIONS	28deg. C, 72%RH 1011hPa	TESTED BY	Chad Lee
TEST MODE	A		

ANTENNA POLARITY & TEST DISTANCE: HORIZONTAL AT 3 M								
NO.	FREQ. (MHz)	EMISSION LEVEL (dBuV/m)	LIMIT (dBuV/m)	MARGIN (dB)	ANTENNA HEIGHT (m)	TABLE ANGLE (Degree)	RAW VALUE (dBuV)	CORRECTION FACTOR (dB/m)
1	40.02	38.30 QP	40.00	-1.70	1.02 H	254	24.61	13.69
2	66.82	37.85 QP	40.00	-2.15	1.15 H	48	30.20	7.65
3	146.52	37.86 QP	43.50	-5.64	1.06 H	214	24.17	13.69
4	250.10	44.65 QP	46.00	-1.35	1.08 H	211	29.09	15.56
5	500.03	39.62 QP	46.00	-6.38	1.00 H	121	16.31	23.31
6	575.11	38.89 QP	46.00	-7.11	1.00 H	124	14.19	24.70
ANTENNA POLARITY & TEST DISTANCE: VERTICAL AT 3 M								
NO.	FREQ. (MHz)	EMISSION LEVEL (dBuV/m)	LIMIT (dBuV/m)	MARGIN (dB)	ANTENNA HEIGHT (m)	TABLE ANGLE (Degree)	RAW VALUE (dBuV)	CORRECTION FACTOR (dB/m)
1	30.00	39.87 QP	40.00	-0.13	1.00 V	358	20.79	19.08
2	125.12	41.21 QP	43.50	-2.29	1.00 V	215	28.44	12.77
3	143.01	41.12 QP	43.50	-2.38	1.21 V	264	27.63	13.49
4	250.01	44.02 QP	46.00	-1.98	1.00 V	41	28.46	15.56
5	425.21	41.18 QP	46.00	-4.82	1.00 V	135	20.25	20.93
6	575.24	39.65 QP	46.00	-6.35	1.00 V	302	14.95	24.70

- REMARKS:**
1. Emission level (dBuV/m) = Raw Value (dBuV) + Correction Factor (dB/m).
 2. Correction Factor (dB/m) = Antenna Factor (dB/m) + Cable Factor (dB).
 3. The other emission levels were very low against the limit.
 4. Margin value = Emission level – Limit value.



A D T

EUT TEST CONDITION		MEASUREMENT DETAIL	
CHANNEL	Channel 157	FREQUENCY RANGE	Below 1000MHz
INPUT POWER	120Vac, 60Hz	DETECTOR FUNCTION	Quasi-Peak
ENVIRONMENTAL CONDITIONS	28deg. C, 75%RH 1007hPa	TESTED BY	Chad Lee
TEST MODE	B		

ANTENNA POLARITY & TEST DISTANCE: HORIZONTAL AT 3 M								
NO.	FREQ. (MHz)	EMISSION LEVEL (dBuV/m)	LIMIT (dBuV/m)	MARGIN (dB)	ANTENNA HEIGHT (m)	TABLE ANGLE (Degree)	RAW VALUE (dBuV)	CORRECTION FACTOR (dB/m)
1	36.33	33.98 QP	40.00	-6.02	2.65 H	18	18.64	15.34
2	87.14	38.19 QP	40.00	-1.81	2.29 H	100	28.25	9.94
3	250.00	44.96 QP	46.00	-1.04	1.56 H	103	29.40	15.56
4	500.00	36.98 QP	46.00	-9.02	1.08 H	145	13.67	23.31
5	625.00	34.52 QP	46.00	-11.48	1.12 H	63	9.19	25.33
6	750.00	30.96 QP	46.00	-15.04	1.00 H	12	4.17	26.79
ANTENNA POLARITY & TEST DISTANCE: VERTICAL AT 3 M								
NO.	FREQ. (MHz)	EMISSION LEVEL (dBuV/m)	LIMIT (dBuV/m)	MARGIN (dB)	ANTENNA HEIGHT (m)	TABLE ANGLE (Degree)	RAW VALUE (dBuV)	CORRECTION FACTOR (dB/m)
1	36.33	34.52 QP	40.00	-5.48	1.00 V	69	19.18	15.34
2	87.16	38.19 QP	40.00	-1.81	1.00 V	11	28.25	9.94
3	250.01	42.36 QP	46.00	-3.64	1.09 V	121	26.80	15.56
4	500.00	35.36 QP	46.00	-10.64	1.33 V	59	12.05	23.31
5	625.00	30.96 QP	46.00	-15.04	1.29 V	142	5.63	25.33
6	750.00	30.25 QP	46.00	-15.75	1.82 V	22	3.46	26.79

- REMARKS:**
1. Emission level (dBuV/m) = Raw Value (dBuV) + Correction Factor (dB/m).
 2. Correction Factor (dB/m) = Antenna Factor (dB/m) + Cable Factor (dB).
 3. The other emission levels were very low against the limit.
 4. Margin value = Emission level – Limit value.



A D T

EUT TEST CONDITION		MEASUREMENT DETAIL	
CHANNEL	Channel 157	FREQUENCY RANGE	Below 1000MHz
INPUT POWER	120Vac, 60Hz	DETECTOR FUNCTION	Quasi-Peak
ENVIRONMENTAL CONDITIONS	28deg. C, 72%RH 1010hPa	TESTED BY	Chad Lee
TEST MODE	C		

ANTENNA POLARITY & TEST DISTANCE: HORIZONTAL AT 3 M								
NO.	FREQ. (MHz)	EMISSION LEVEL (dBuV/m)	LIMIT (dBuV/m)	MARGIN (dB)	ANTENNA HEIGHT (m)	TABLE ANGLE (Degree)	RAW VALUE (dBuV)	CORRECTION FACTOR (dB/m)
1	39.72	38.16 QP	40.00	-1.84	1.17 H	203	24.34	13.82
2	66.92	38.47 QP	40.00	-1.53	1.36 H	111	30.82	7.65
3	146.59	41.66 QP	43.50	-1.84	1.08 H	219	27.96	13.70
4	500.01	44.33 QP	46.00	-1.67	1.06 H	321	21.02	23.31
5	575.03	38.67 QP	46.00	-7.33	1.00 H	39	13.97	24.70
6	625.01	38.52 QP	46.00	-7.48	1.17 H	142	13.19	25.33
ANTENNA POLARITY & TEST DISTANCE: VERTICAL AT 3 M								
NO.	FREQ. (MHz)	EMISSION LEVEL (dBuV/m)	LIMIT (dBuV/m)	MARGIN (dB)	ANTENNA HEIGHT (m)	TABLE ANGLE (Degree)	RAW VALUE (dBuV)	CORRECTION FACTOR (dB/m)
1	30.03	39.63 QP	40.00	-0.37	1.18 V	214	20.57	19.06
2	90.21	41.33 QP	43.50	-2.17	1.00 V	296	30.99	10.34
3	125.02	41.38 QP	43.50	-2.12	1.05 V	224	28.61	12.77
4	250.01	44.18 QP	46.00	-1.82	1.13 V	308	28.62	15.56
5	425.01	40.39 QP	46.00	-5.61	1.17 V	20	19.46	20.93
6	575.02	39.11 QP	46.00	-6.89	1.00 V	72	14.41	24.70

- REMARKS:**
1. Emission level (dBuV/m) = Raw Value (dBuV) + Correction Factor (dB/m).
 2. Correction Factor (dB/m) = Antenna Factor (dB/m) + Cable Factor (dB).
 3. The other emission levels were very low against the limit.
 4. Margin value = Emission level – Limit value.



A D T

EUT TEST CONDITION		MEASUREMENT DETAIL	
CHANNEL	Channel 157	FREQUENCY RANGE	Below 1000MHz
INPUT POWER	120Vac, 60Hz	DETECTOR FUNCTION	Quasi-Peak
ENVIRONMENTAL CONDITIONS	28deg. C, 75%RH 1010hPa	TESTED BY	Chad Lee
TEST MODE	D		

ANTENNA POLARITY & TEST DISTANCE: HORIZONTAL AT 3 M								
NO.	FREQ. (MHz)	EMISSION LEVEL (dBuV/m)	LIMIT (dBuV/m)	MARGIN (dB)	ANTENNA HEIGHT (m)	TABLE ANGLE (Degree)	RAW VALUE (dBuV)	CORRECTION FACTOR (dB/m)
1	35.79	34.29 QP	40.00	-5.71	1.25 H	324	18.71	15.58
2	86.29	37.19 QP	40.00	-2.81	1.08 H	124	27.37	9.82
3	249.98	44.89 QP	46.00	-1.11	1.07 H	127	29.33	15.56
4	500.02	40.19 QP	46.00	-5.81	1.20 H	163	16.88	23.31
5	624.97	39.19 QP	46.00	-6.81	1.02 H	318	13.86	25.33
6	776.39	35.17 QP	46.00	-10.83	1.28 H	229	7.94	27.23
ANTENNA POLARITY & TEST DISTANCE: VERTICAL AT 3 M								
NO.	FREQ. (MHz)	EMISSION LEVEL (dBuV/m)	LIMIT (dBuV/m)	MARGIN (dB)	ANTENNA HEIGHT (m)	TABLE ANGLE (Degree)	RAW VALUE (dBuV)	CORRECTION FACTOR (dB/m)
1	31.98	38.69 QP	40.00	-1.31	1.17 V	218	20.86	17.83
2	86.27	38.91 QP	40.00	-1.09	1.03 V	6	29.09	9.82
3	142.68	41.39 QP	43.50	-2.11	1.11 V	207	27.92	13.47
4	250.01	44.93 QP	46.00	-1.07	1.13 V	319	29.37	15.56
5	425.02	38.91 QP	46.00	-7.09	1.39 V	176	17.98	20.93
6	500.01	38.16 QP	46.00	-7.84	1.00 V	39	14.85	23.31
7	624.97	37.61 QP	46.00	-8.39	1.23 V	214	12.28	25.33

- REMARKS:**
1. Emission level (dBuV/m) = Raw Value (dBuV) + Correction Factor (dB/m).
 2. Correction Factor (dB/m) = Antenna Factor (dB/m) + Cable Factor (dB).
 3. The other emission levels were very low against the limit.
 4. Margin value = Emission level – Limit value.

4.2 CONDUCTED EMISSION MEASUREMENT

4.2.1 LIMITS OF CONDUCTED EMISSION MEASUREMENT

FREQUENCY OF EMISSION (MHz)	CONDUCTED LIMIT (dB μ V)	
	Quasi-peak	Average
0.15 ~ 0.5	66 to 56	56 to 46
0.5 ~ 5	56	46
5 ~ 30	60	50

- NOTE:** 1. The lower limit shall apply at the transition frequencies.
2. The limit decreases in line with the logarithm of the frequency in the range of 0.15 to 0.50MHz.
3. All emanations from a class A/B digital device or system, including any network of conductors and apparatus connected thereto, shall not exceed the level of field strengths specified above.

4.2.2 TEST INSTRUMENTS

DESCRIPTION & MANUFACTURER	MODEL NO.	SERIAL NO.	CALIBRATED DATE	CALIBRATED UNTIL
ROHDE & SCHWARZ Test Receiver	ESCS 30	838251/021	Mar. 05, 2009	Mar. 04, 2010
ROHDE & SCHWARZ Artificial Mains Network (for EUT)	ESH3-Z5	100218	Nov. 26, 2008	Nov. 25, 2009
LISN With Adapter (for EUT)	AD10	C10Ada-001	Nov. 26, 2008	Nov. 25, 2009
ROHDE & SCHWARZ Artificial Mains Network (for peripherals)	ESH3-Z5	100219	Nov. 20, 2008	Nov. 19, 2009
Software	ADT_Cond_V7.3.7	NA	NA	NA
Software	ADT_ISN_V7.3.7	NA	NA	NA
RF cable (JYEBAO)	5D-FB	Cable-C10.01	Feb. 26, 2009	Feb. 25, 2010
SUHNER Terminator (For ROHDE & SCHWARZ LISN)	65BNC-5001	E1-010773	Feb. 27, 2009	Feb. 26, 2010

- NOTE:** 1. The calibration interval of the above test instruments is 12 months and the calibrations are traceable to NML/ROC and NIST/USA.
2. The test was performed in Shielded Room No. 10.
3. The VCCI Site Registration No. C-1852.



A D T

4.2.3 TEST PROCEDURES

- a. The EUT was placed 0.4 meters from the conducting wall of the shielded room with EUT being connected to the power mains through a line impedance stabilization network (LISN). Other support units were connected to the power mains through another LISN. The two LISNs provide 50 ohm/ 50uH of coupling impedance for the measuring instrument.
- b. Both lines of the power mains connected to the EUT were checked for maximum conducted interference.
- c. The frequency range from 150kHz to 30MHz was searched. Emission levels under (Limit - 20dB) was not recorded.

4.2.4 DEVIATION FROM TEST STANDARD

No deviation.

4.2.5 TEST SETUP

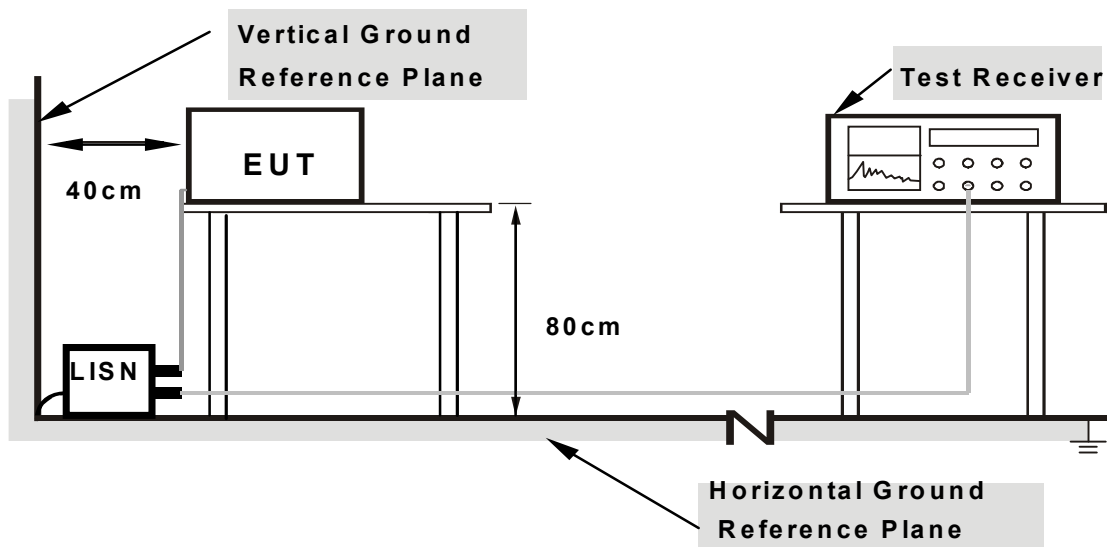

Note: 1. Support units were connected to second LISN.

2. Both of LISNs (AMN) are 80 cm from EUT and at least 80 from other units and other metal planes

For the actual test configuration, please refer to the attached file (Test Setup Photo).

4.2.6 EUT OPERATING CONDITIONS

Same as 4.1.6



4.2.7 TEST RESULTS

CONDUCTED WORST-CASE DATA : Draft 802.11n (20MHz) OFDM MODULATION

EUT TEST CONDITION		MEASUREMENT DETAIL	
CHANNEL	Channel 157	PHASE	Line 1
INPUT POWER	120Vac, 60Hz	6dB BANDWIDTH	9kHz
ENVIRONMENTAL CONDITIONS	25deg. C, 72%RH, 1011hPa	TESTED BY	Nick Chen
TEST MODE	A		

No	Freq. [MHz]	Corr. Factor (dB)	Reading Value		Emission Level		Limit		Margin	
			[dB (uV)]		[dB (uV)]		[dB (uV)]		(dB)	
			Q.P.	AV.	Q.P.	AV.	Q.P.	AV.	Q.P.	AV.
1	0.150	0.12	42.29	-	42.41	-	66.00	56.00	-23.59	-
2	0.177	0.12	39.37	-	39.49	-	64.61	54.61	-25.12	-
3	0.520	0.22	42.59	-	42.81	-	56.00	46.00	-13.19	-
4	4.027	0.36	35.91	-	36.27	-	56.00	46.00	-19.73	-
5	10.207	0.67	47.46	-	48.13	-	60.00	50.00	-11.87	-
6	24.184	1.49	36.78	-	38.27	-	60.00	50.00	-21.73	-

- REMARKS:**
1. Q.P. and AV. are abbreviations of quasi-peak and average individually.
 2. "-": The Quasi-peak reading value also meets average limit and measurement with the average detector is unnecessary.
 3. The emission levels of other frequencies were very low against the limit.
 4. Margin value = Emission level - Limit value
 5. Correction factor = Insertion loss + Cable loss
 6. Emission Level = Correction Factor + Reading Value.

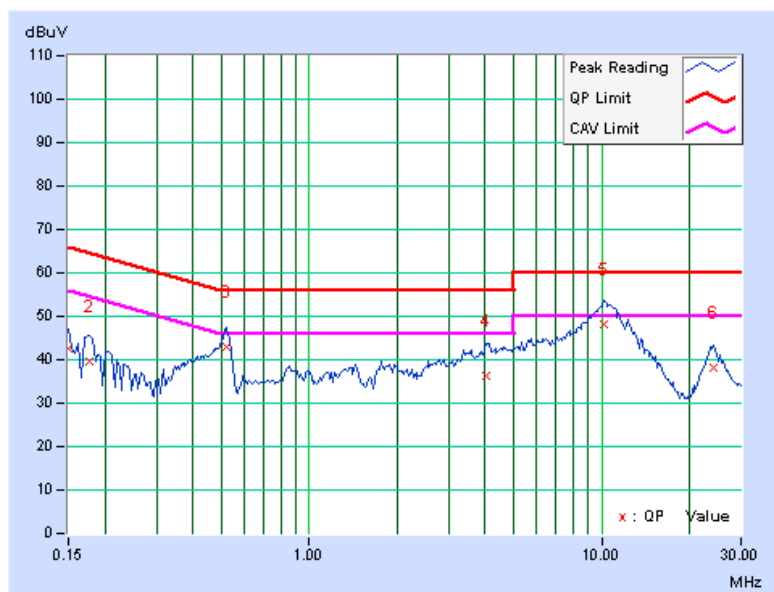



A D T

EUT TEST CONDITION		MEASUREMENT DETAIL	
CHANNEL	Channel 157	PHASE	Line 2
INPUT POWER	120Vac, 60Hz	6dB BANDWIDTH	9kHz
ENVIRONMENTAL CONDITIONS	25deg. C, 72%RH, 1011hPa	TESTED BY	Nick Chen
TEST MODE	A		

No	Freq. [MHz]	Corr. Factor (dB)	Reading Value		Emission Level		Limit		Margin	
			[dB (uV)]		[dB (uV)]		[dB (uV)]		(dB)	
			Q.P.	AV.	Q.P.	AV.	Q.P.	AV.	Q.P.	AV.
1	0.150	0.09	44.15	-	44.24	-	66.00	56.00	-21.76	-
2	0.177	0.09	42.72	-	42.81	-	64.61	54.61	-21.80	-
3	0.396	0.20	39.99	-	40.19	-	57.93	47.93	-17.75	-
4	0.524	0.20	46.37	33.30	46.57	33.50	56.00	46.00	-9.43	-12.50
5	10.531	0.55	41.93	-	42.48	-	60.00	50.00	-17.52	-
6	24.051	1.12	31.53	-	32.65	-	60.00	50.00	-27.35	-

- REMARKS:**
1. Q.P. and AV. are abbreviations of quasi-peak and average individually.
 2. "-": The Quasi-peak reading value also meets average limit and measurement with the average detector is unnecessary.
 3. The emission levels of other frequencies were very low against the limit.
 4. Margin value = Emission level - Limit value
 5. Correction factor = Insertion loss + Cable loss
 6. Emission Level = Correction Factor + Reading Value.

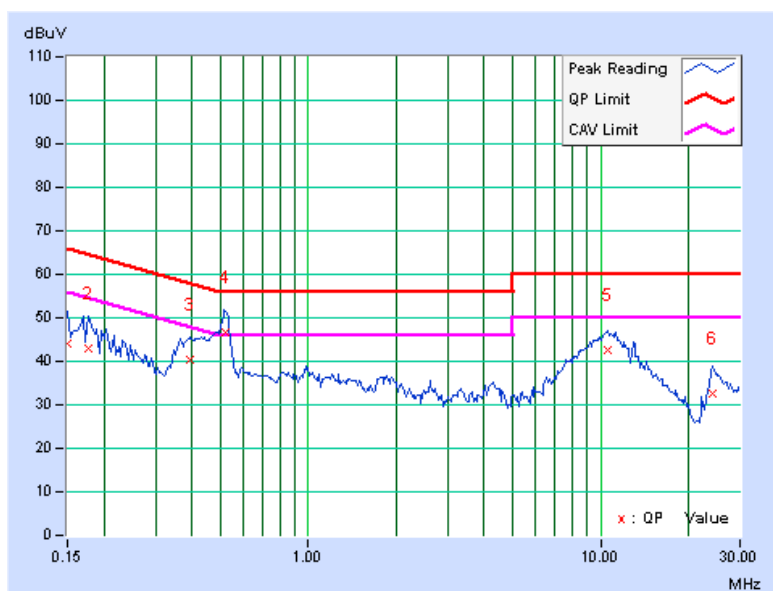



A D T

EUT TEST CONDITION		MEASUREMENT DETAIL	
CHANNEL	Channel 157	PHASE	Line 1
INPUT POWER	120Vac, 60Hz	6dB BANDWIDTH	9kHz
ENVIRONMENTAL CONDITIONS	28deg. C, 77%RH, 1010hPa	TESTED BY	Nick Chen
TEST MODE	B		

No	Freq. [MHz]	Corr. Factor (dB)	Reading Value		Emission Level		Limit		Margin	
			[dB (uV)]		[dB (uV)]		[dB (uV)]		(dB)	
			Q.P.	AV.	Q.P.	AV.	Q.P.	AV.	Q.P.	AV.
1	0.151	0.12	45.09	-	45.21	-	65.93	55.93	-20.72	-
2	0.284	0.16	40.42	-	40.58	-	60.70	50.70	-20.11	-
3	0.494	0.22	37.98	-	38.20	-	56.10	46.10	-17.90	-
4	1.080	0.24	22.41	-	22.65	-	56.00	46.00	-33.35	-
5	14.969	1.03	26.80	-	27.83	-	60.00	50.00	-32.17	-
6	29.943	1.61	24.04	-	25.65	-	60.00	50.00	-34.35	-

- REMARKS:**
1. Q.P. and AV. are abbreviations of quasi-peak and average individually.
 2. "-": The Quasi-peak reading value also meets average limit and measurement with the average detector is unnecessary.
 3. The emission levels of other frequencies were very low against the limit.
 4. Margin value = Emission level - Limit value
 5. Correction factor = Insertion loss + Cable loss
 6. Emission Level = Correction Factor + Reading Value.

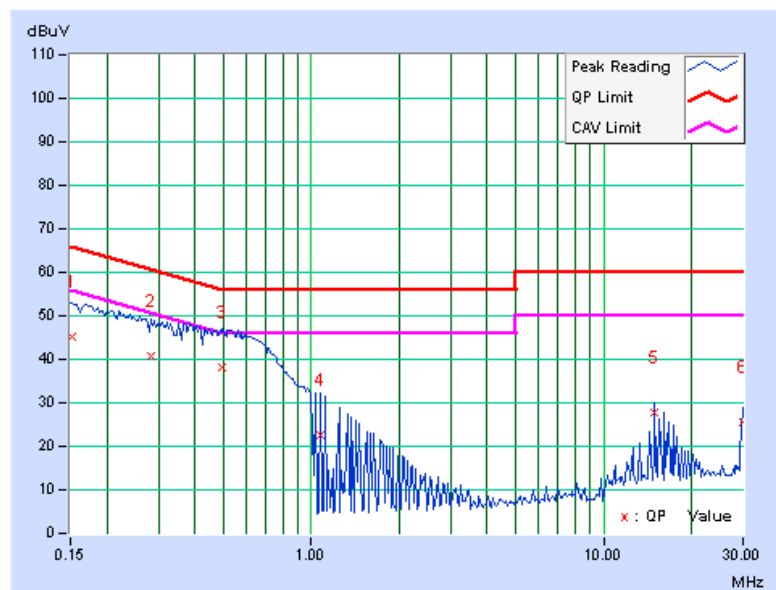



A D T

EUT TEST CONDITION		MEASUREMENT DETAIL	
CHANNEL	Channel 157	PHASE	Line 2
INPUT POWER	120Vac, 60Hz	6dB BANDWIDTH	9kHz
ENVIRONMENTAL CONDITIONS	28deg. C, 77%RH, 1010hPa	TESTED BY	Nick Chen
TEST MODE	B		

No	Freq. [MHz]	Corr. Factor (dB)	Reading Value		Emission Level		Limit		Margin	
			[dB (uV)]		[dB (uV)]		[dB (uV)]		(dB)	
			Q.P.	AV.	Q.P.	AV.	Q.P.	AV.	Q.P.	AV.
1	0.189	0.09	43.95	-	44.04	-	64.08	54.08	-20.04	-
2	0.318	0.15	38.97	-	39.12	-	59.76	49.76	-20.63	-
3	0.500	0.20	37.36	-	37.56	-	56.00	46.00	-18.44	-
4	1.035	0.22	18.21	-	18.43	-	56.00	46.00	-37.57	-
5	15.549	0.82	29.03	-	29.85	-	60.00	50.00	-30.15	-
6	17.271	0.91	28.25	-	29.16	-	60.00	50.00	-30.84	-

- REMARKS:**
1. Q.P. and AV. are abbreviations of quasi-peak and average individually.
 2. "-": The Quasi-peak reading value also meets average limit and measurement with the average detector is unnecessary.
 3. The emission levels of other frequencies were very low against the limit.
 4. Margin value = Emission level - Limit value
 5. Correction factor = Insertion loss + Cable loss
 6. Emission Level = Correction Factor + Reading Value.

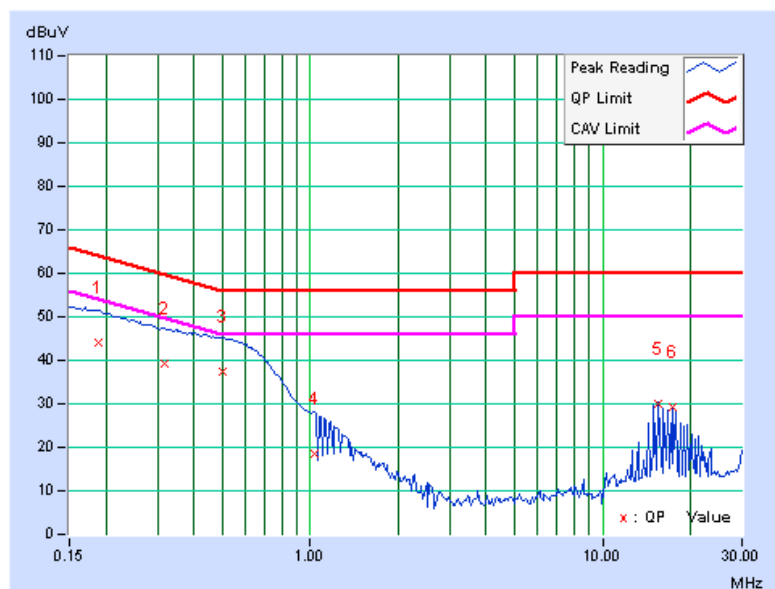



A D T

EUT TEST CONDITION		MEASUREMENT DETAIL	
CHANNEL	Channel 157	PHASE	Line 1
INPUT POWER	120Vac, 60Hz	6dB BANDWIDTH	9kHz
ENVIRONMENTAL CONDITIONS	25deg. C, 72%RH, 1011hPa	TESTED BY	Nick Chen
TEST MODE	C		

No	Freq. [MHz]	Corr. Factor (dB)	Reading Value		Emission Level		Limit		Margin	
			[dB (uV)]		[dB (uV)]		[dB (uV)]		(dB)	
			Q.P.	AV.	Q.P.	AV.	Q.P.	AV.	Q.P.	AV.
1	0.166	0.12	39.26	-	39.38	-	65.18	55.18	-25.80	-
2	0.517	0.22	42.57	-	42.79	-	56.00	46.00	-13.21	-
3	1.445	0.26	32.09	-	32.35	-	56.00	46.00	-23.65	-
4	1.879	0.28	32.75	-	33.03	-	56.00	46.00	-22.97	-
5	10.568	0.69	47.73	-	48.42	-	60.00	50.00	-11.58	-
6	23.766	1.49	36.57	-	38.06	-	60.00	50.00	-21.94	-

- REMARKS:**
1. Q.P. and AV. are abbreviations of quasi-peak and average individually.
 2. "-": The Quasi-peak reading value also meets average limit and measurement with the average detector is unnecessary.
 3. The emission levels of other frequencies were very low against the limit.
 4. Margin value = Emission level - Limit value
 5. Correction factor = Insertion loss + Cable loss
 6. Emission Level = Correction Factor + Reading Value.

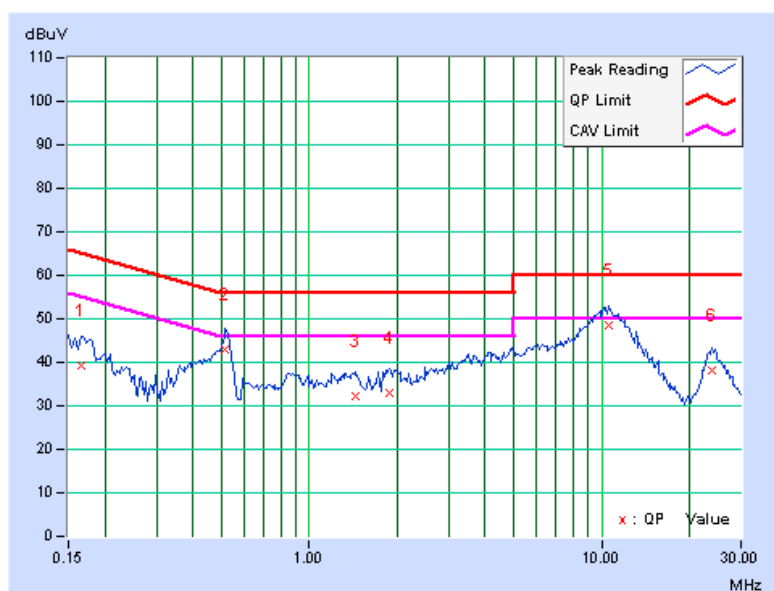



A D T

EUT TEST CONDITION		MEASUREMENT DETAIL	
CHANNEL	Channel 157	PHASE	Line 2
INPUT POWER	120Vac, 60Hz	6dB BANDWIDTH	9kHz
ENVIRONMENTAL CONDITIONS	25deg. C, 72%RH, 1011hPa	TESTED BY	Nick Chen
TEST MODE	C		

No	Freq. [MHz]	Corr. Factor (dB)	Reading Value		Emission Level		Limit		Margin	
			[dB (uV)]		[dB (uV)]		[dB (uV)]		(dB)	
			Q.P.	AV.	Q.P.	AV.	Q.P.	AV.	Q.P.	AV.
1	0.172	0.09	42.41	-	42.50	-	64.86	54.86	-22.36	-
2	0.206	0.09	40.69	-	40.78	-	63.37	53.37	-22.58	-
3	0.518	0.20	46.17	33.10	46.37	33.30	56.00	46.00	-9.63	-12.70
4	1.840	0.25	30.39	-	30.64	-	56.00	46.00	-25.36	-
5	10.521	0.55	42.13	-	42.68	-	60.00	50.00	-17.32	-
6	25.469	1.14	31.28	-	32.42	-	60.00	50.00	-27.58	-

- REMARKS:**
1. Q.P. and AV. are abbreviations of quasi-peak and average individually.
 2. "-": The Quasi-peak reading value also meets average limit and measurement with the average detector is unnecessary.
 3. The emission levels of other frequencies were very low against the limit.
 4. Margin value = Emission level - Limit value
 5. Correction factor = Insertion loss + Cable loss
 6. Emission Level = Correction Factor + Reading Value.

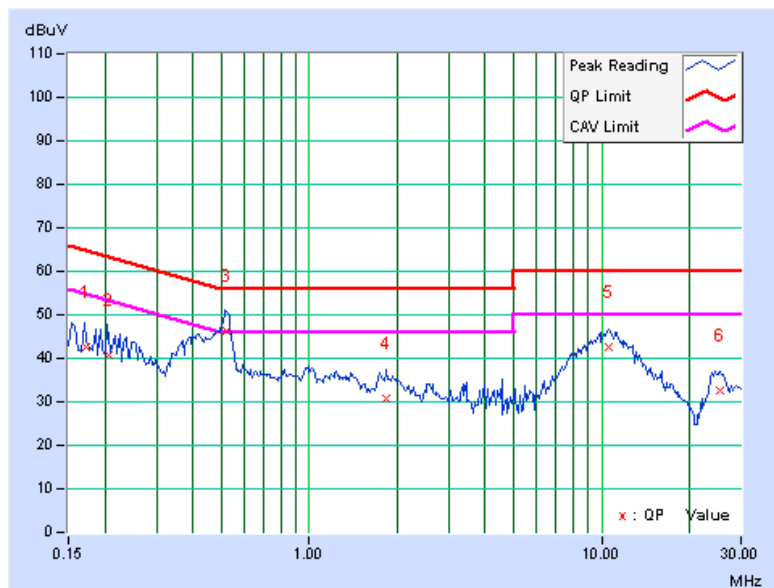



A D T

EUT TEST CONDITION		MEASUREMENT DETAIL	
CHANNEL	Channel 157	PHASE	Line 1
INPUT POWER	120Vac, 60Hz	6dB BANDWIDTH	9kHz
ENVIRONMENTAL CONDITIONS	28deg. C, 77%RH, 1010hPa	TESTED BY	Nick Chen
TEST MODE	D		

No	Freq. [MHz]	Corr. Factor (dB)	Reading Value		Emission Level		Limit		Margin	
			[dB (uV)]		[dB (uV)]		[dB (uV)]		(dB)	
			Q.P.	AV.	Q.P.	AV.	Q.P.	AV.	Q.P.	AV.
1	0.176	0.12	44.67	-	44.79	-	64.65	54.65	-19.86	-
2	0.187	0.12	44.23	-	44.35	-	64.18	54.18	-19.83	-
3	0.369	0.20	38.61	-	38.81	-	58.53	48.53	-19.71	-
4	0.495	0.22	37.67	-	37.89	-	56.08	46.08	-18.19	-
5	16.325	1.13	27.17	-	28.30	-	60.00	50.00	-31.70	-
6	25.890	1.53	32.54	-	34.07	-	60.00	50.00	-25.93	-

- REMARKS:**
1. Q.P. and AV. are abbreviations of quasi-peak and average individually.
 2. "-": The Quasi-peak reading value also meets average limit and measurement with the average detector is unnecessary.
 3. The emission levels of other frequencies were very low against the limit.
 4. Margin value = Emission level - Limit value
 5. Correction factor = Insertion loss + Cable loss
 6. Emission Level = Correction Factor + Reading Value.

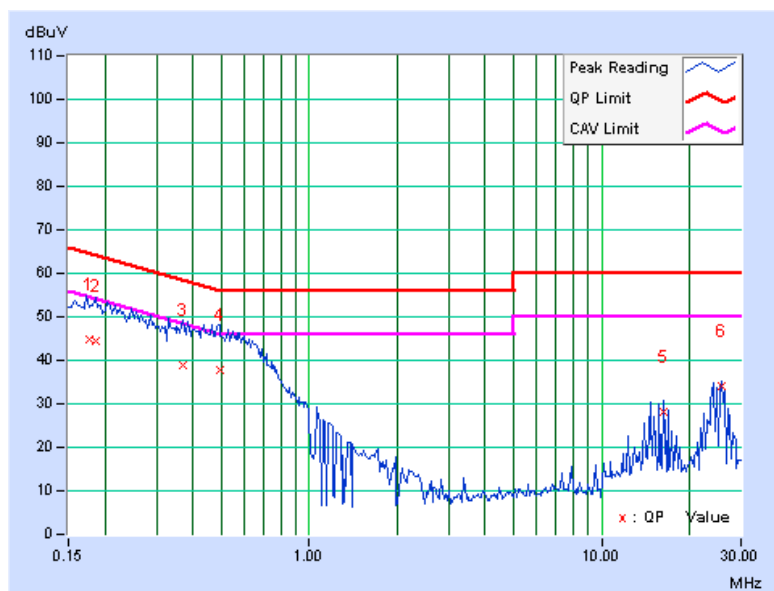



A D T

EUT TEST CONDITION		MEASUREMENT DETAIL	
CHANNEL	Channel 157	PHASE	Line 2
INPUT POWER	120Vac, 60Hz	6dB BANDWIDTH	9kHz
ENVIRONMENTAL CONDITIONS	28deg. C, 77%RH, 1010hPa	TESTED BY	Nick Chen
TEST MODE	D		

No	Freq. [MHz]	Corr. Factor (dB)	Reading Value		Emission Level		Limit		Margin	
			[dB (uV)]		[dB (uV)]		[dB (uV)]		(dB)	
			Q.P.	AV.	Q.P.	AV.	Q.P.	AV.	Q.P.	AV.
1	0.150	0.09	44.84	-	44.93	-	66.00	56.00	-21.07	-
2	0.232	0.11	29.62	-	29.73	-	62.38	52.38	-32.65	-
3	0.420	0.20	29.41	-	29.61	-	57.46	47.46	-27.85	-
4	0.612	0.21	26.89	-	27.10	-	56.00	46.00	-28.90	-
5	14.642	0.77	23.59	-	24.36	-	60.00	50.00	-35.64	-
6	24.788	1.13	25.73	-	26.86	-	60.00	50.00	-33.14	-

- REMARKS:**
1. Q.P. and AV. are abbreviations of quasi-peak and average individually.
 2. "-": The Quasi-peak reading value also meets average limit and measurement with the average detector is unnecessary.
 3. The emission levels of other frequencies were very low against the limit.
 4. Margin value = Emission level - Limit value
 5. Correction factor = Insertion loss + Cable loss
 6. Emission Level = Correction Factor + Reading Value.

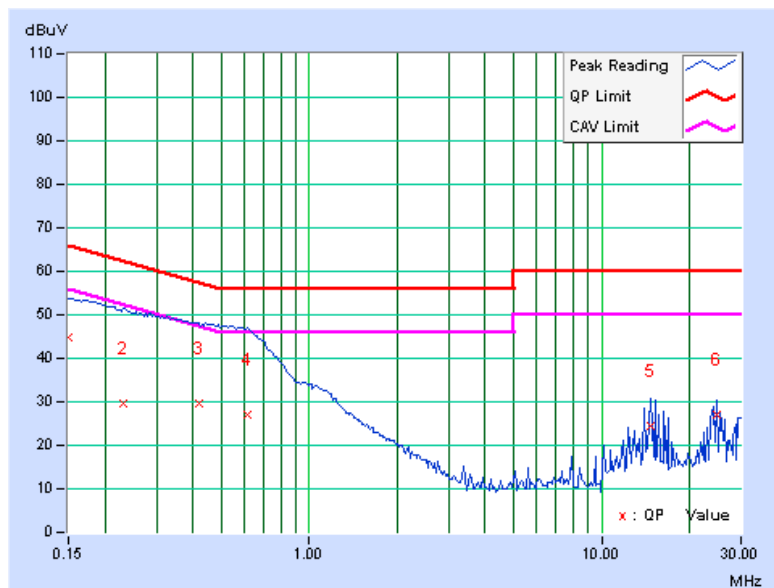



A D T

4.3 6dB BANDWIDTH MEASUREMENT

4.3.1 LIMITS OF 6dB BANDWIDTH MEASUREMENT

The minimum of 6dB Bandwidth Measurement is 0.5MHz.

4.3.2 TEST INSTRUMENTS

DESCRIPTION & MANUFACTURER	MODEL NO.	SERIAL NO.	DATE OF CALIBRATION	DUE DATE OF CALIBRATION
SPECTRUM ANALYZER	FSP 40	100036	Apr. 3, 2009	Apr. 2, 2010

NOTE: The calibration interval of the above test instruments is 12 months and the calibrations are traceable to NML/ROC and NIST/USA.

4.3.3 TEST PROCEDURE

The transmitter output was connected to the spectrum analyzer through an attenuator. The bandwidth of the fundamental frequency was measured by spectrum analyzer with 100kHz RBW and 300kHz VBW. The 6dB bandwidth is defined as the total spectrum the power of which is higher than peak power minus 6dB.

4.3.4 DEVIATION FROM TEST STANDARD

No deviation

4.3.5 TEST SETUP

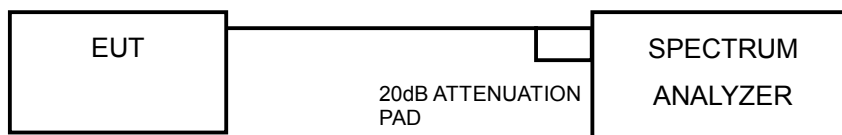

4.3.6 EUT OPERATING CONDITIONS

The software provided by client to enable the EUT under transmission condition continuously at lowest, middle and highest channel frequencies individually.



A D T

4.3.7 TEST RESULTS

802.11a OFDM MODULATION

MODULATION TYPE	BPSK	TRANSFER RATE	6.0Mbps
INPUT POWER	120Vac, 60Hz	ENVIRONMENTAL CONDITIONS	25deg.C, 65% RH, 1010hPa
TESTED BY	Chad Lee	TEST MODE	A

CHANNEL	CHANNEL FREQUENCY (MHz)	6dB BANDWIDTH (MHz)		MINIMUM LIMIT (MHz)	PASS / FAIL
		CHAIN 0	CHAIN 1		
149	5745	16.10	16.40	0.5	PASS
157	5785	16.39	16.44	0.5	PASS
165	5825	16.39	16.42	0.5	PASS



A D T

FOR CHAIN 0: CH 149

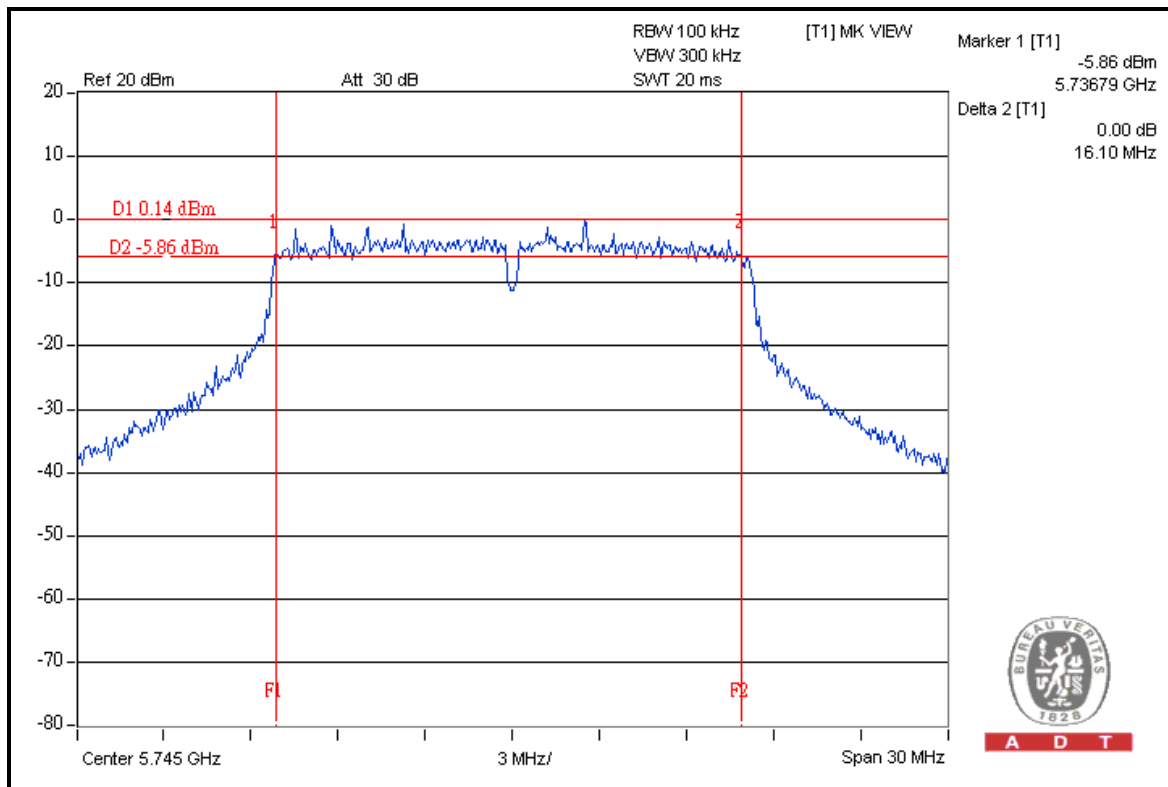

CH 157

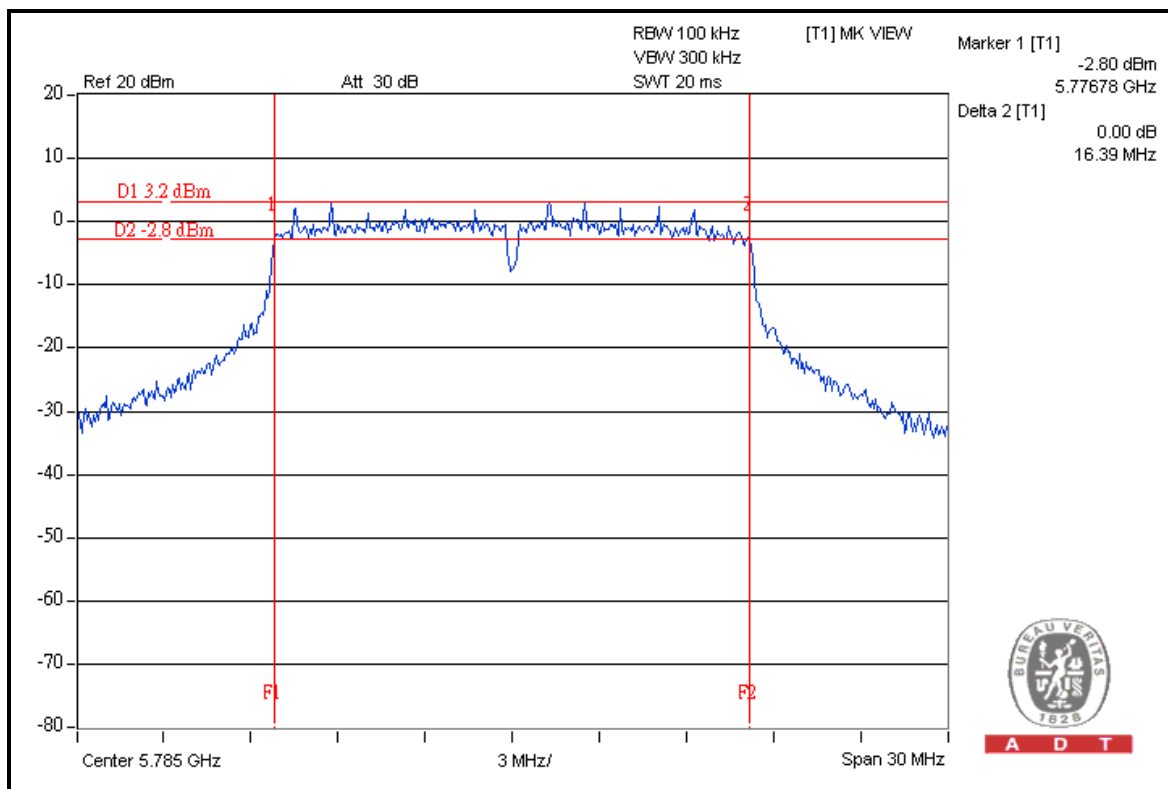



A D T

CH 165

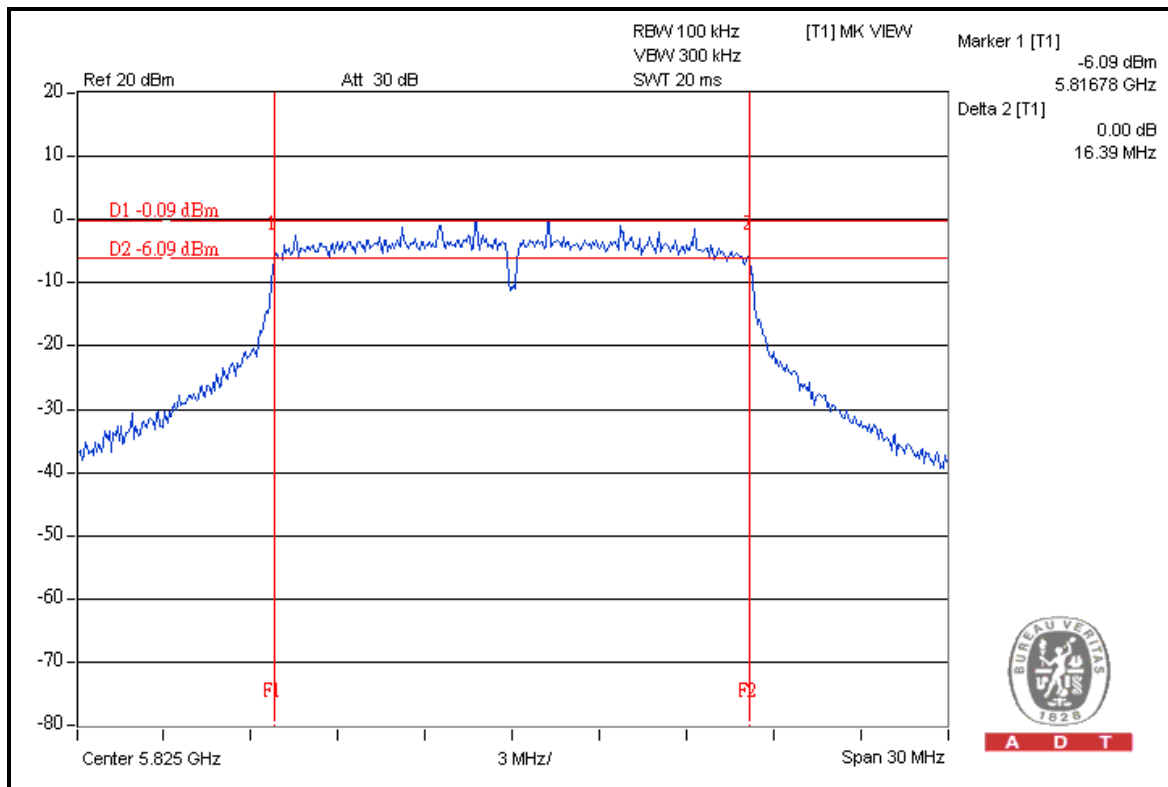

FOR CHAIN 1: CH 149

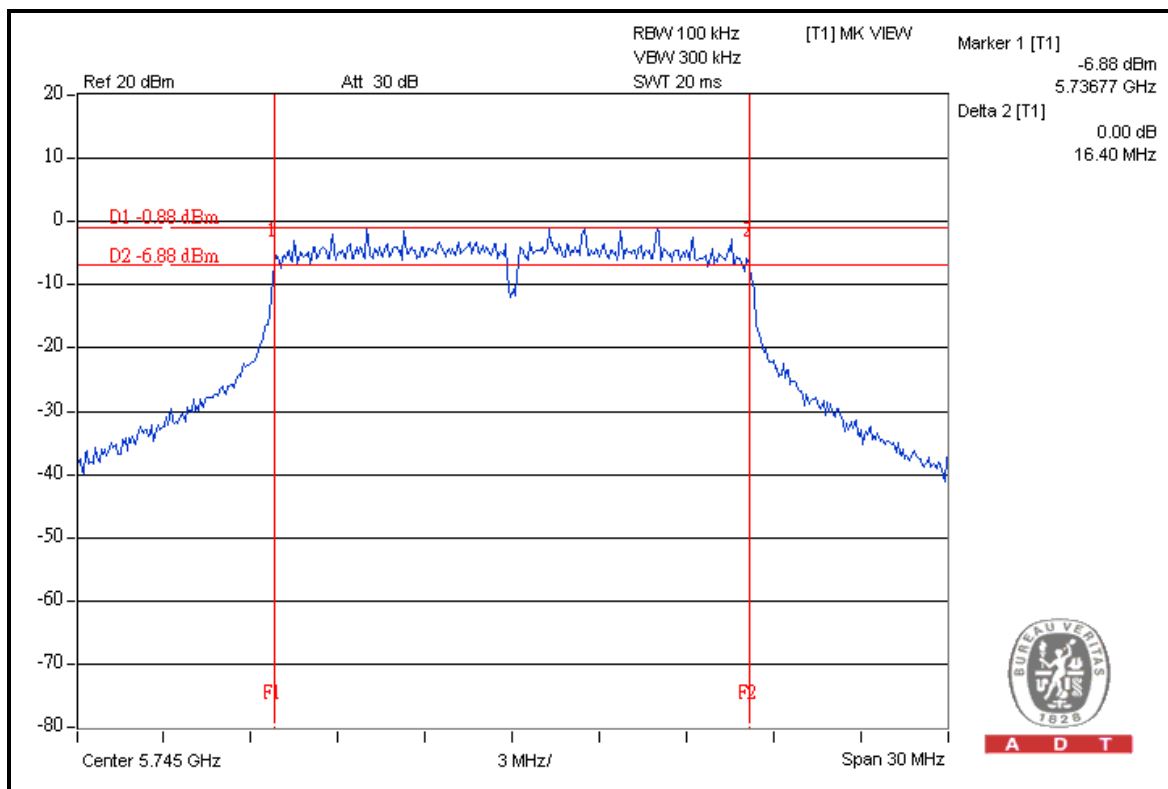



A D T

CH 157

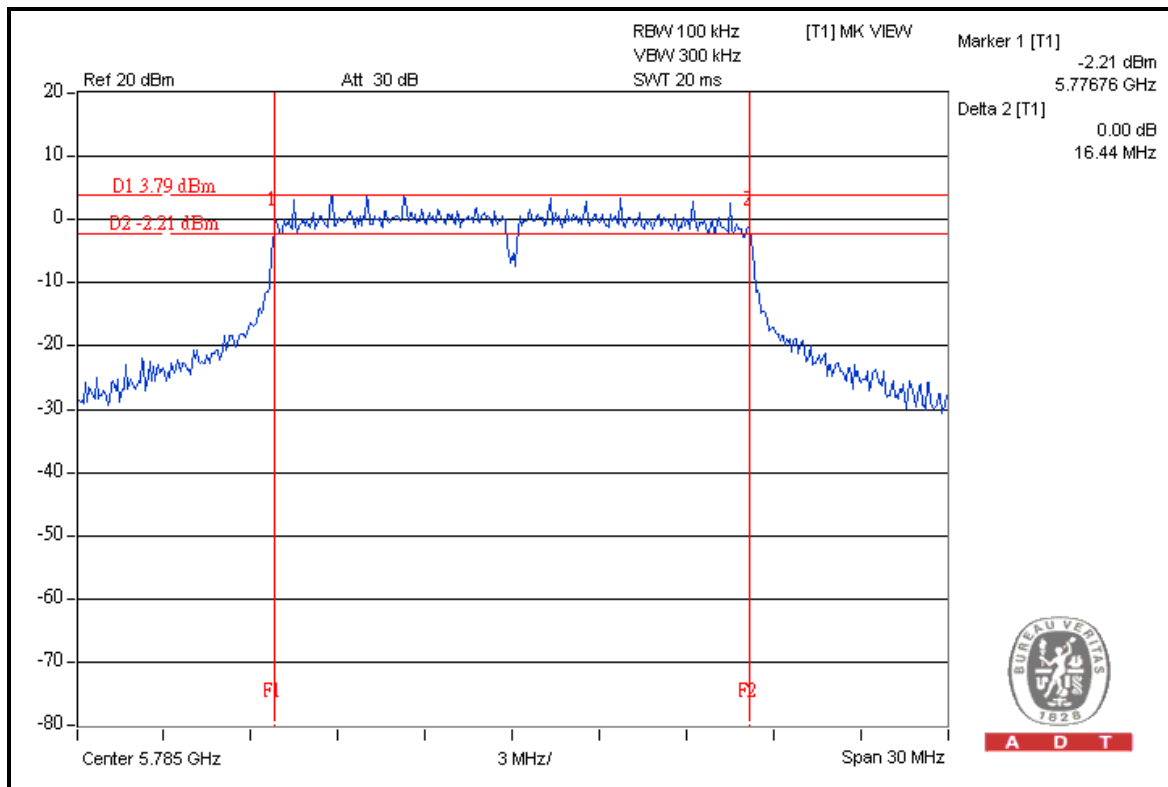

CH 165

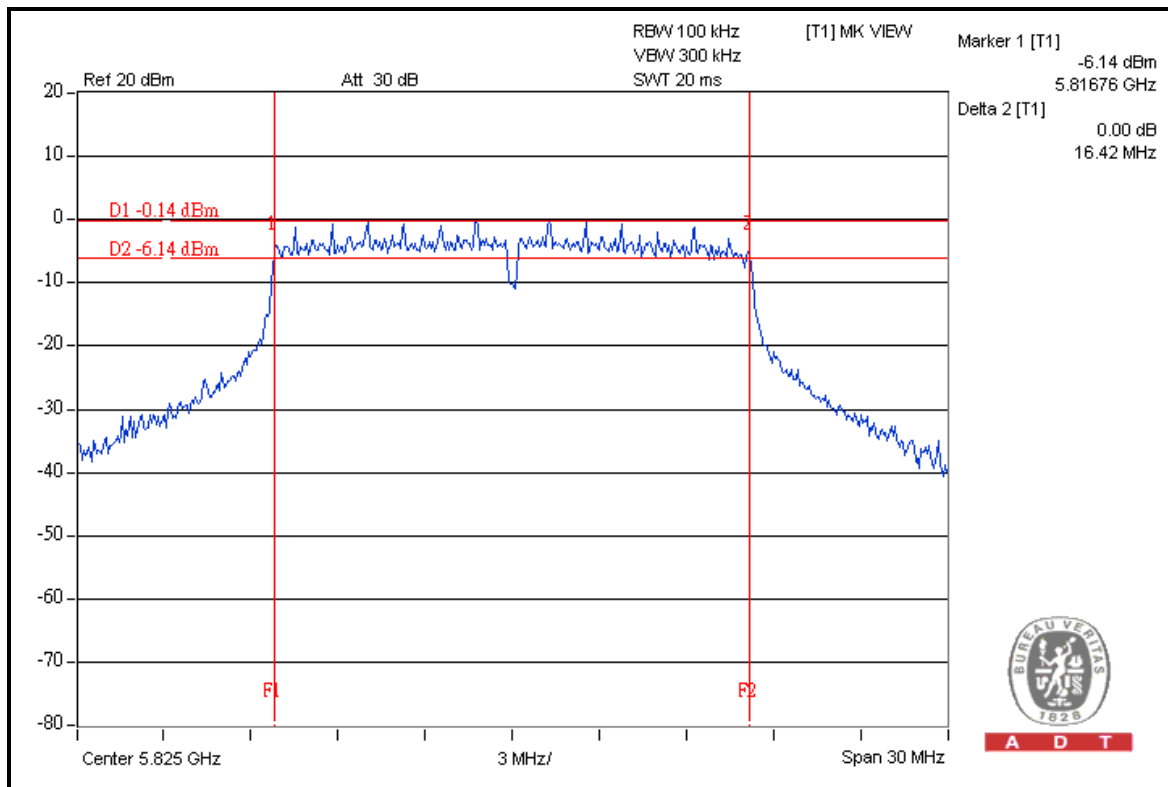



A D T

MODULATION TYPE	BPSK	TRANSFER RATE	6.0Mbps
INPUT POWER	120Vac, 60Hz	ENVIRONMENTAL CONDITIONS	25deg.C, 65% RH, 1010hPa
TESTED BY	Chad Lee	TEST MODE	C

CHANNEL	CHANNEL FREQUENCY (MHz)	6dB BANDWIDTH (MHz)		MINIMUM LIMIT (MHz)	PASS / FAIL
		CHAIN 0	CHAIN 1		
149	5745	16.39	16.43	0.5	PASS
157	5785	16.40	16.45	0.5	PASS
165	5825	16.41	16.42	0.5	PASS



A D T

FOR CHAIN 0: CH 149

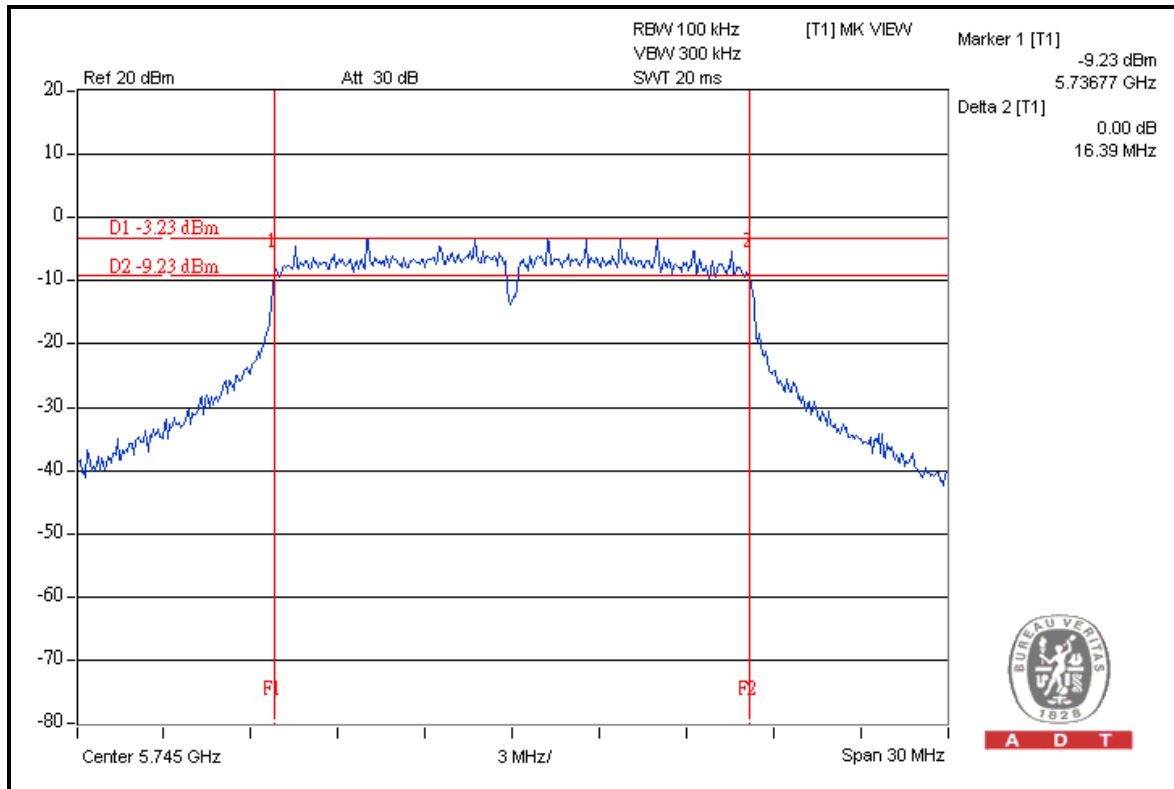

CH 157

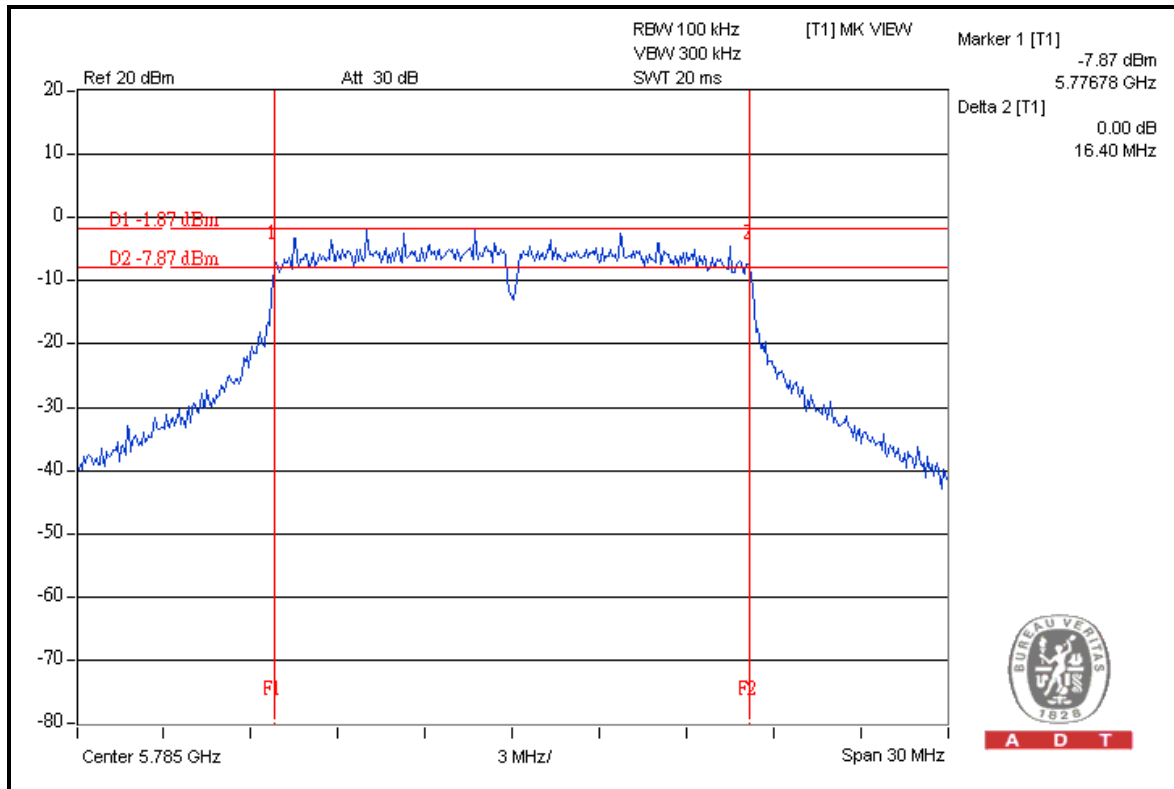



A D T

CH 165

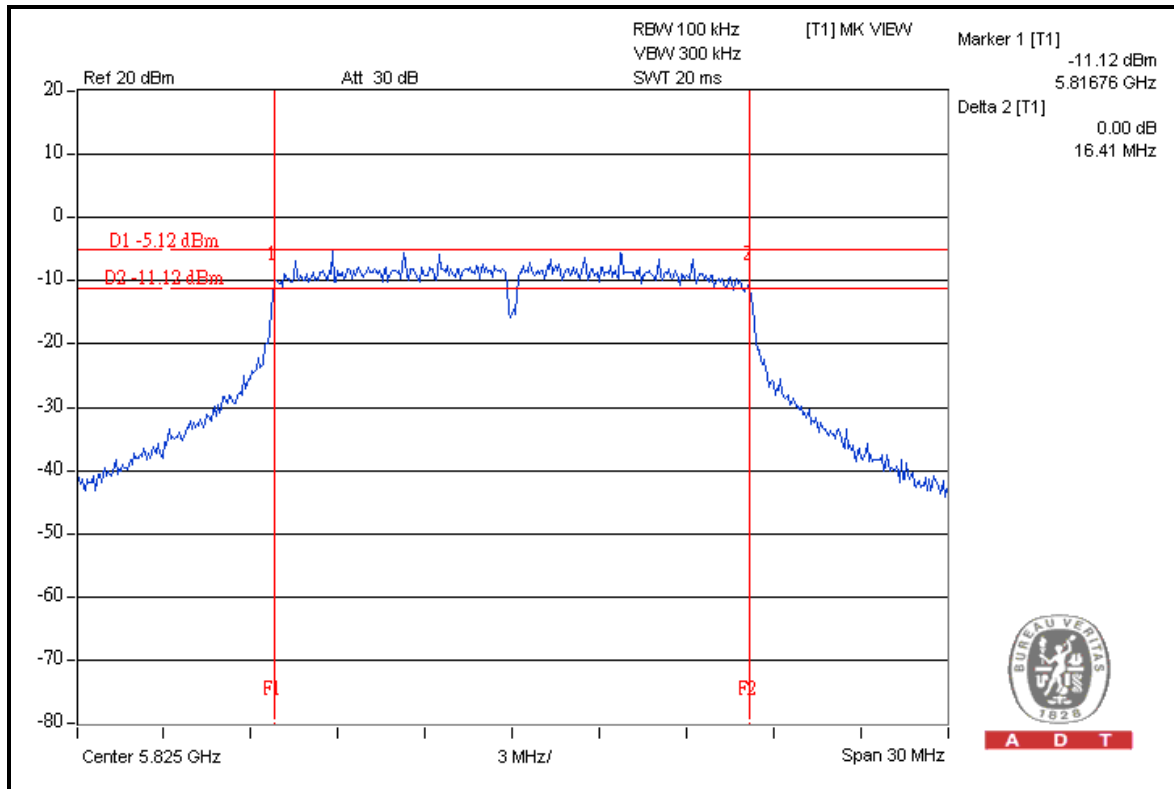

FOR CHAIN 1: CH 149

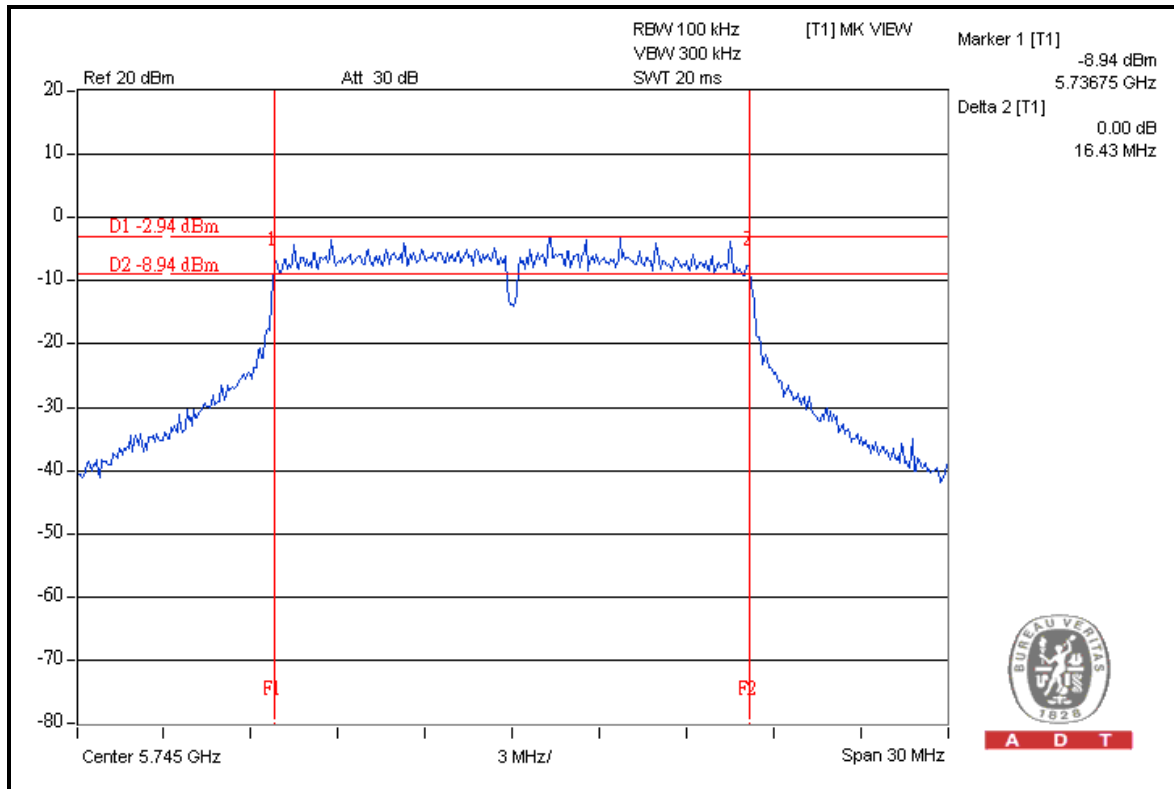



A D T

CH 157

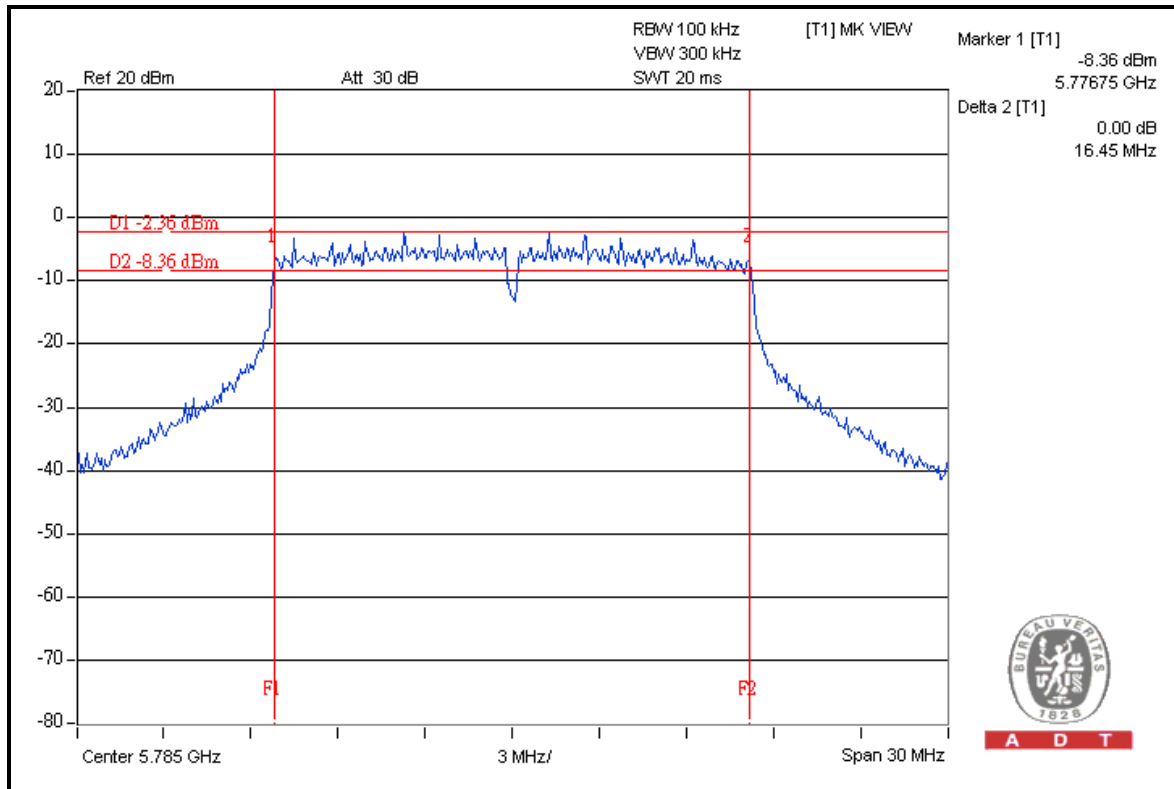

CH 165

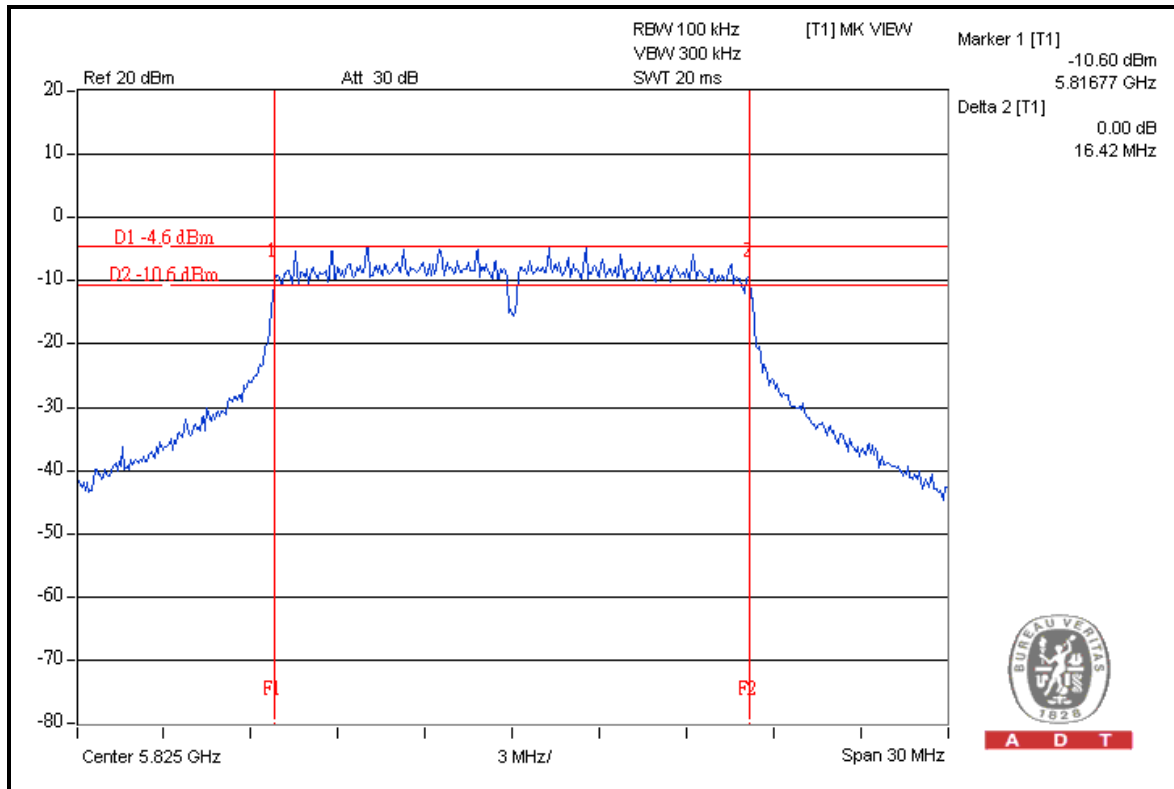



A D T

DRAFT 802.11n (20MHz) OFDM MODULATION

MODULATION TYPE	BPSK	TRANSFER RATE	6.5Mbps
INPUT POWER	120Vac, 60Hz	ENVIRONMENTAL CONDITIONS	25deg.C, 65% RH, 1010hPa
TESTED BY	Chad Lee	TEST MODE	A

CHANNEL	CHANNEL FREQUENCY (MHz)	6dB BANDWIDTH (MHz)		MINIMUM LIMIT (MHz)	PASS / FAIL
		CHAIN 0	CHAIN 1		
149	5745	16.39	16.39	0.5	PASS
157	5785	16.34	16.40	0.5	PASS
165	5825	16.39	16.40	0.5	PASS



A D T

FOR CHAIN 0: CH 149

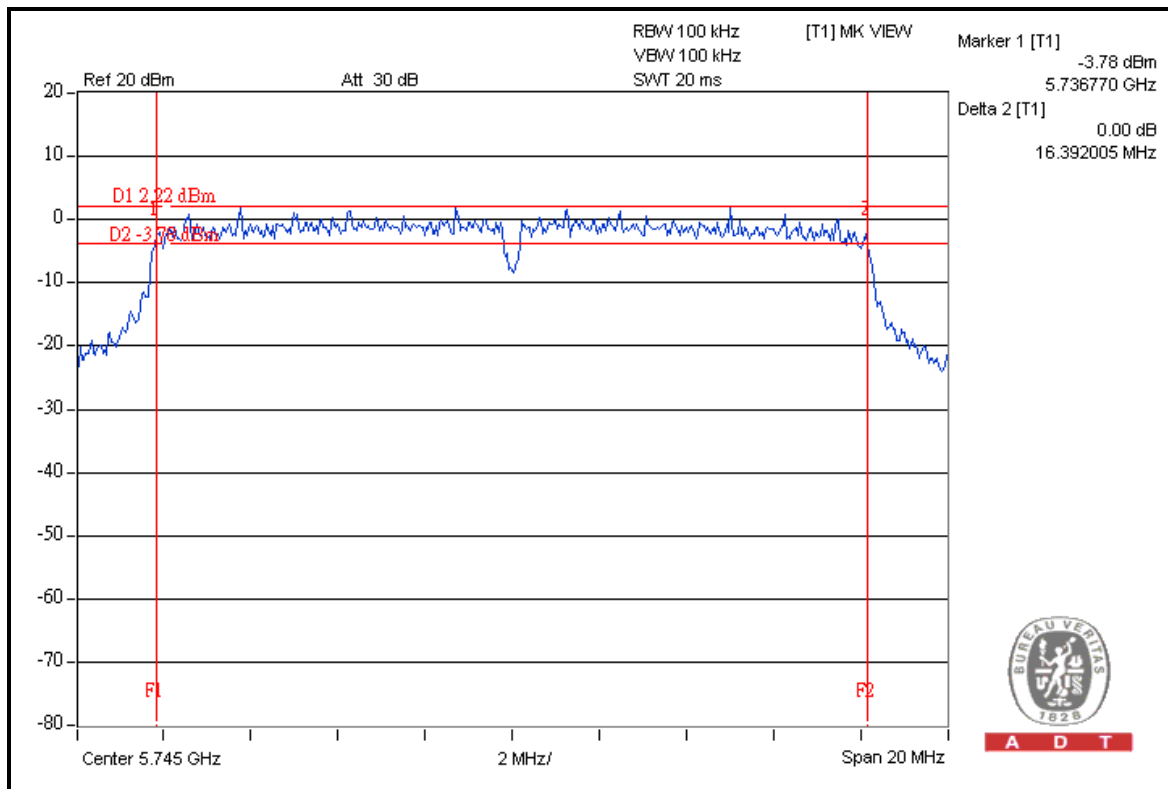

CH 157

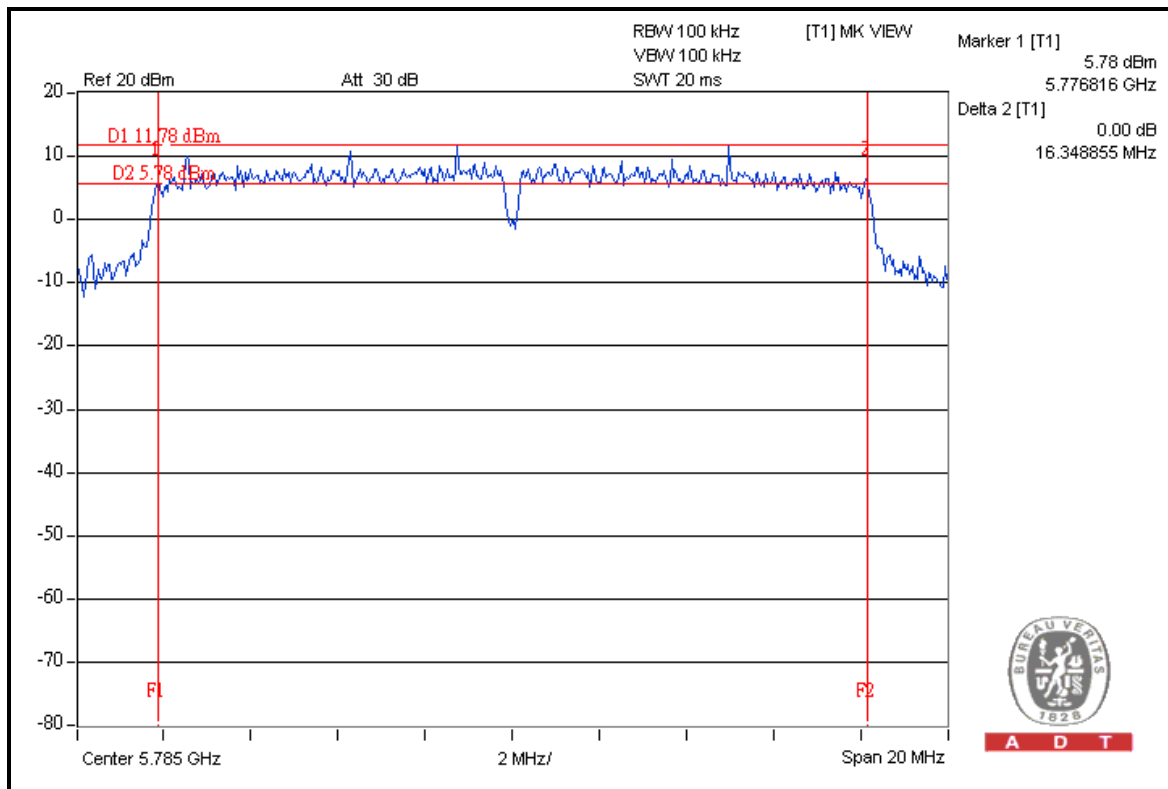



A D T

CH 165

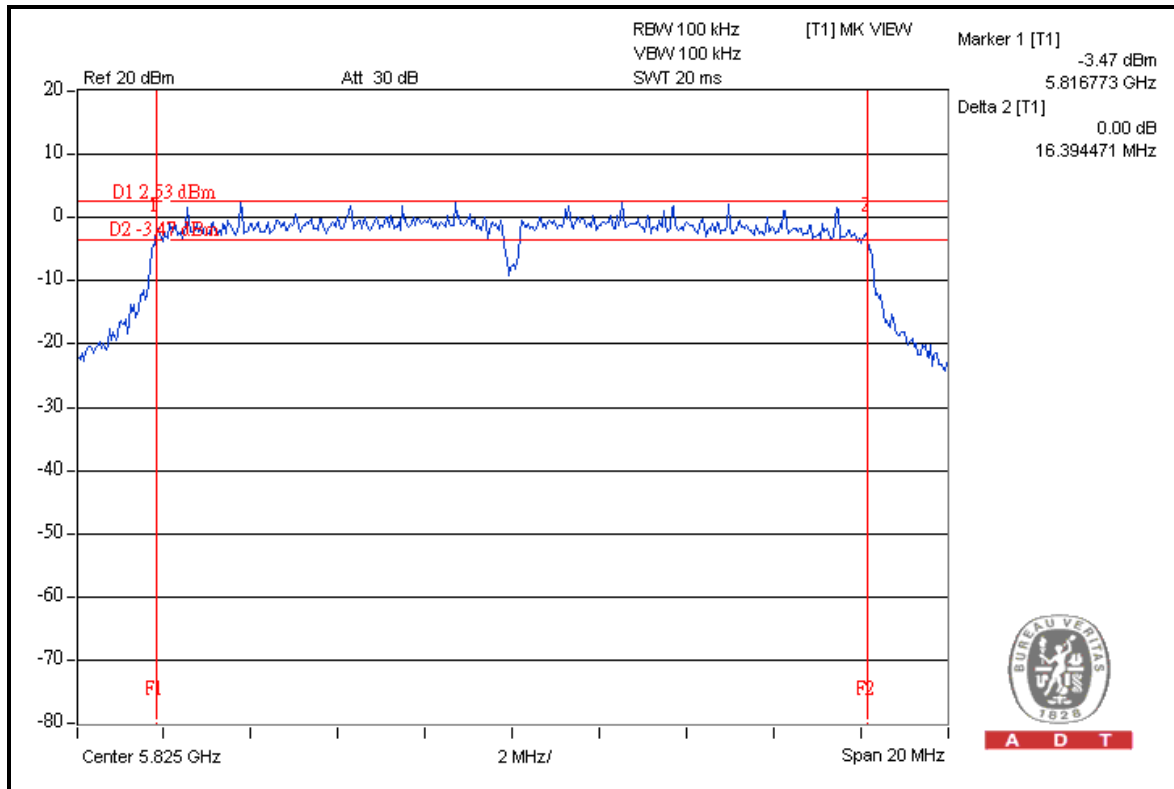

FOR CHAIN 1: CH 149

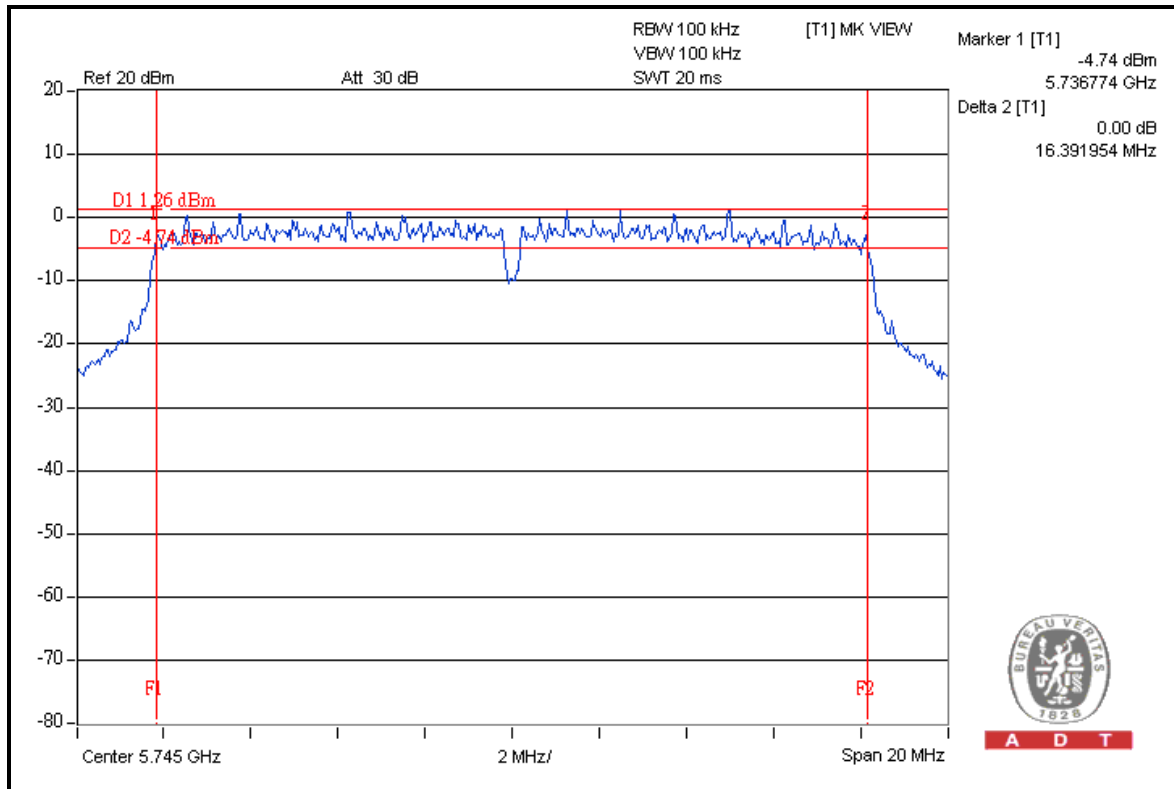



A D T

CH 157

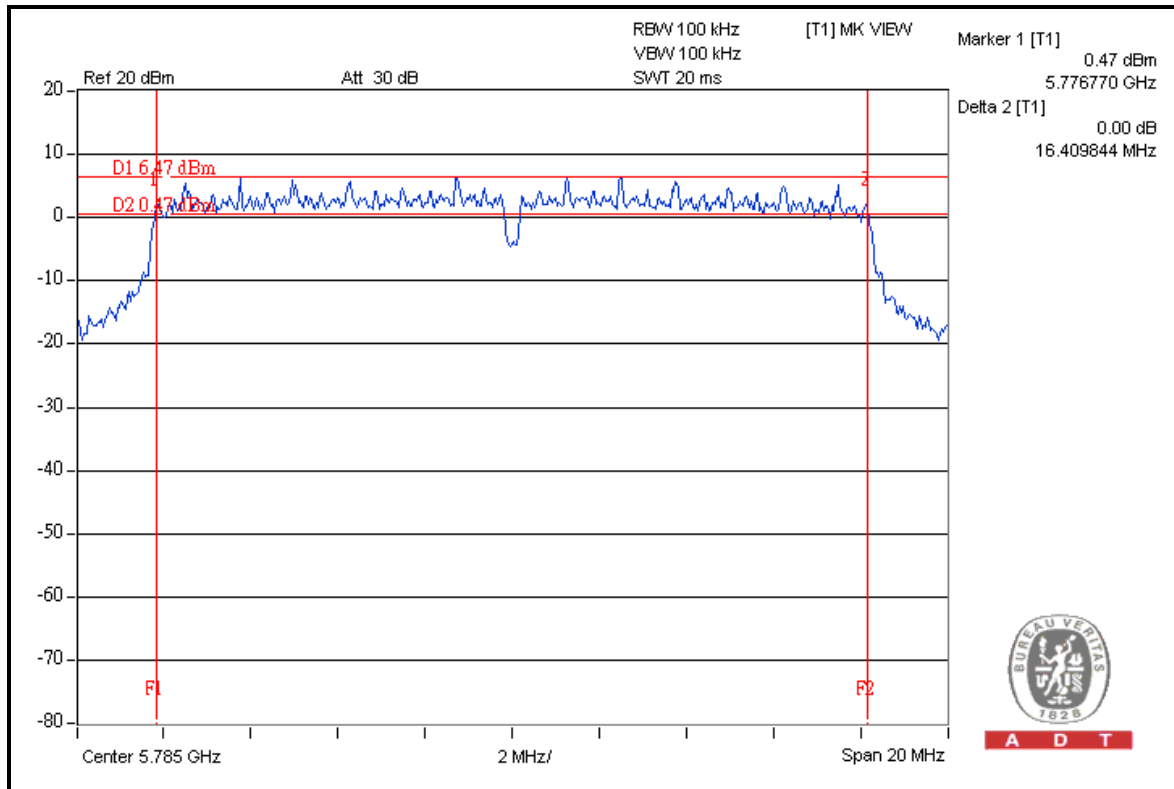

CH 165

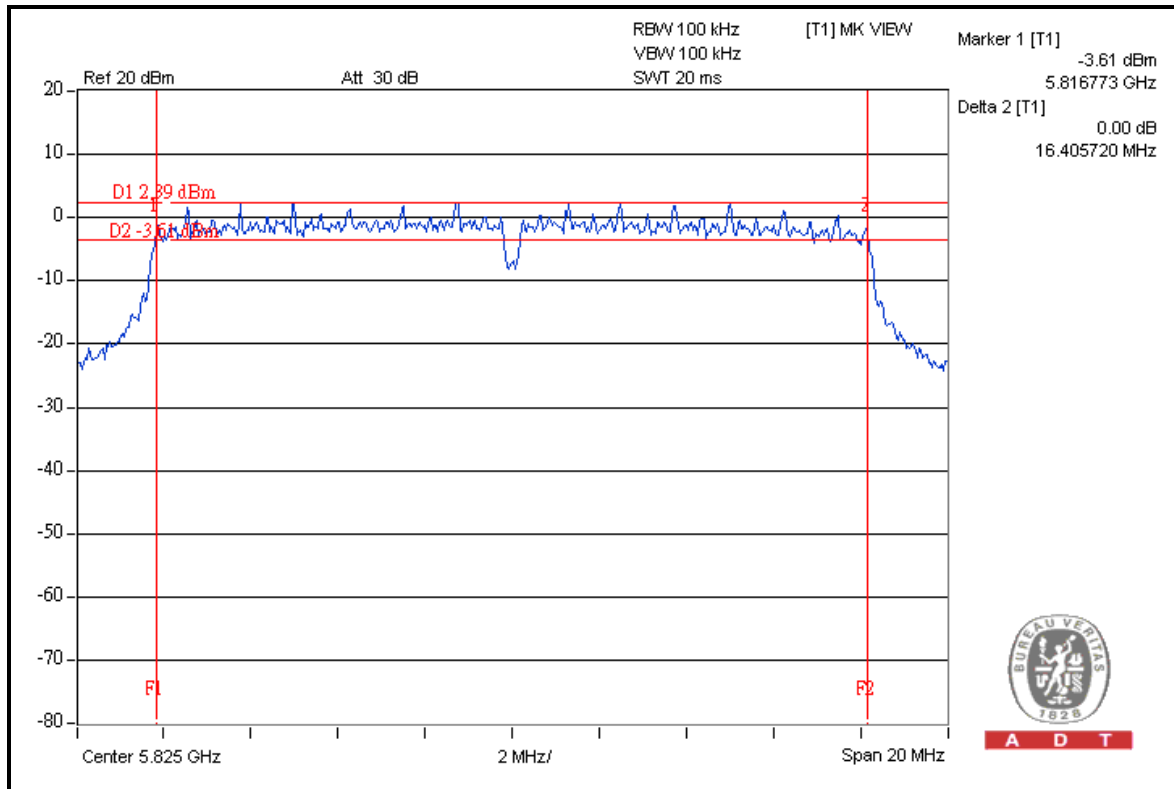



A D T

MODULATION TYPE	BPSK	TRANSFER RATE	6.5Mbps
INPUT POWER	120Vac, 60Hz	ENVIRONMENTAL CONDITIONS	25deg.C, 65% RH, 1010hPa
TESTED BY	Chad Lee	TEST MODE	C

CHANNEL	CHANNEL FREQUENCY (MHz)	6dB BANDWIDTH (MHz)		MINIMUM LIMIT (MHz)	PASS / FAIL
		CHAIN 0	CHAIN 1		
149	5745	16.34	16.40	0.5	PASS
157	5785	16.42	16.45	0.5	PASS
165	5825	16.12	16.43	0.5	PASS



A D T

FOR CHAIN 0: CH 149

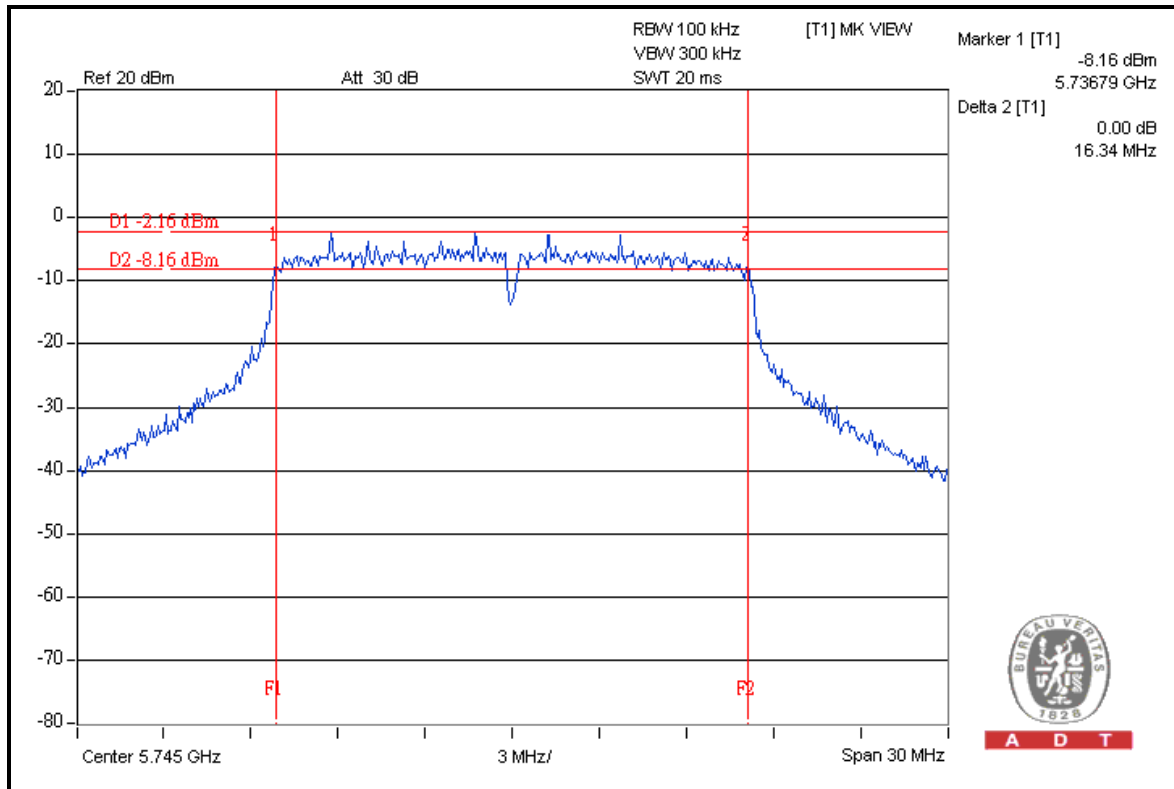

CH 157

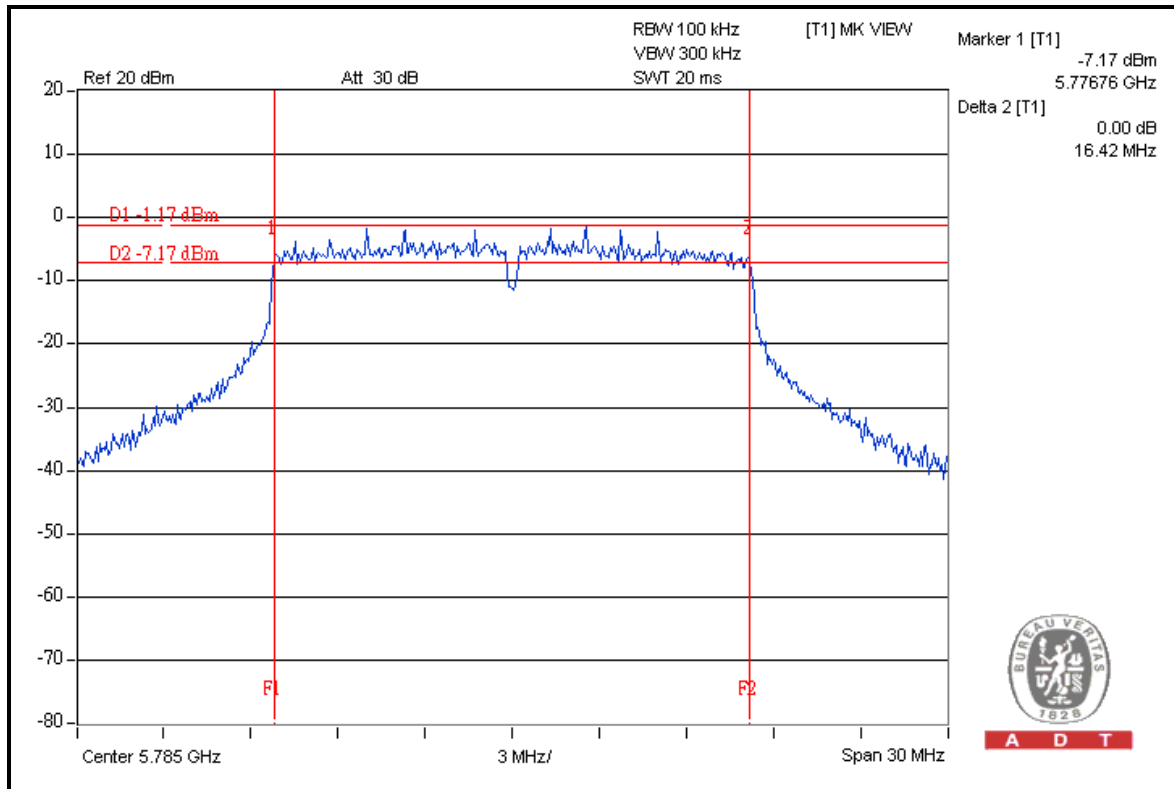



A D T

CH 165

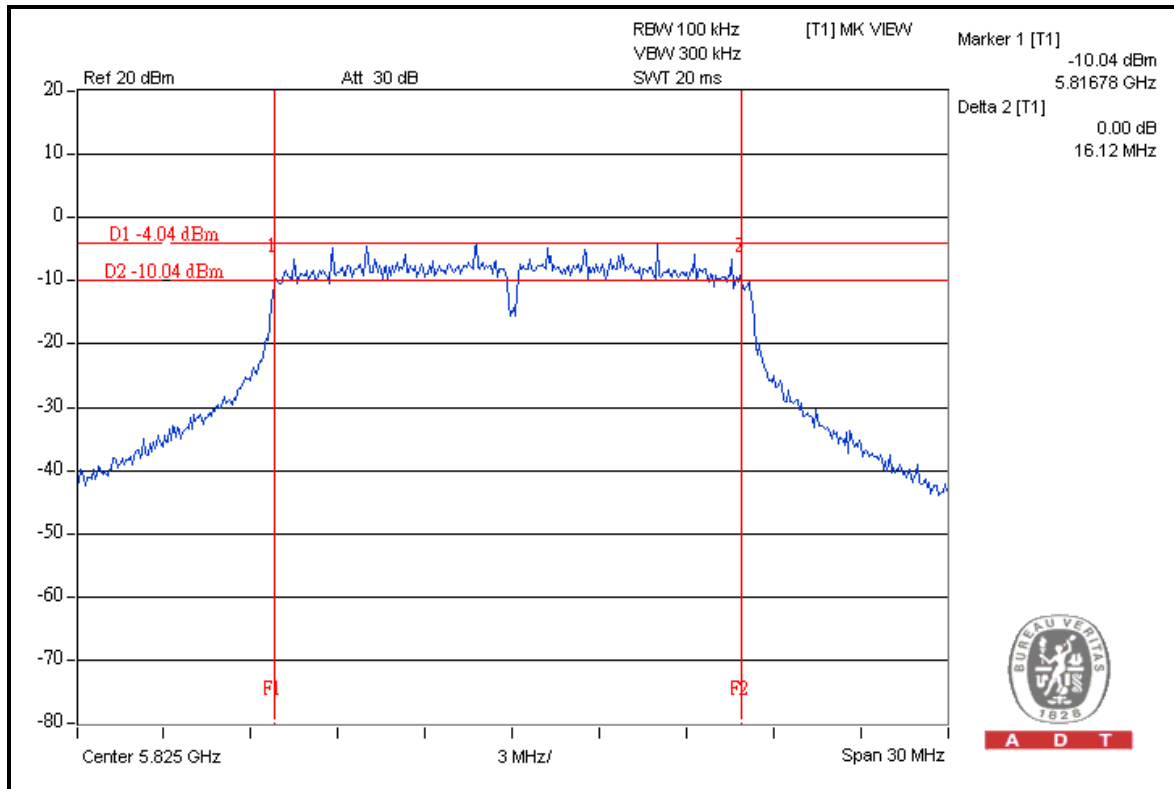

A D T

FOR CHAIN 1: CH 149

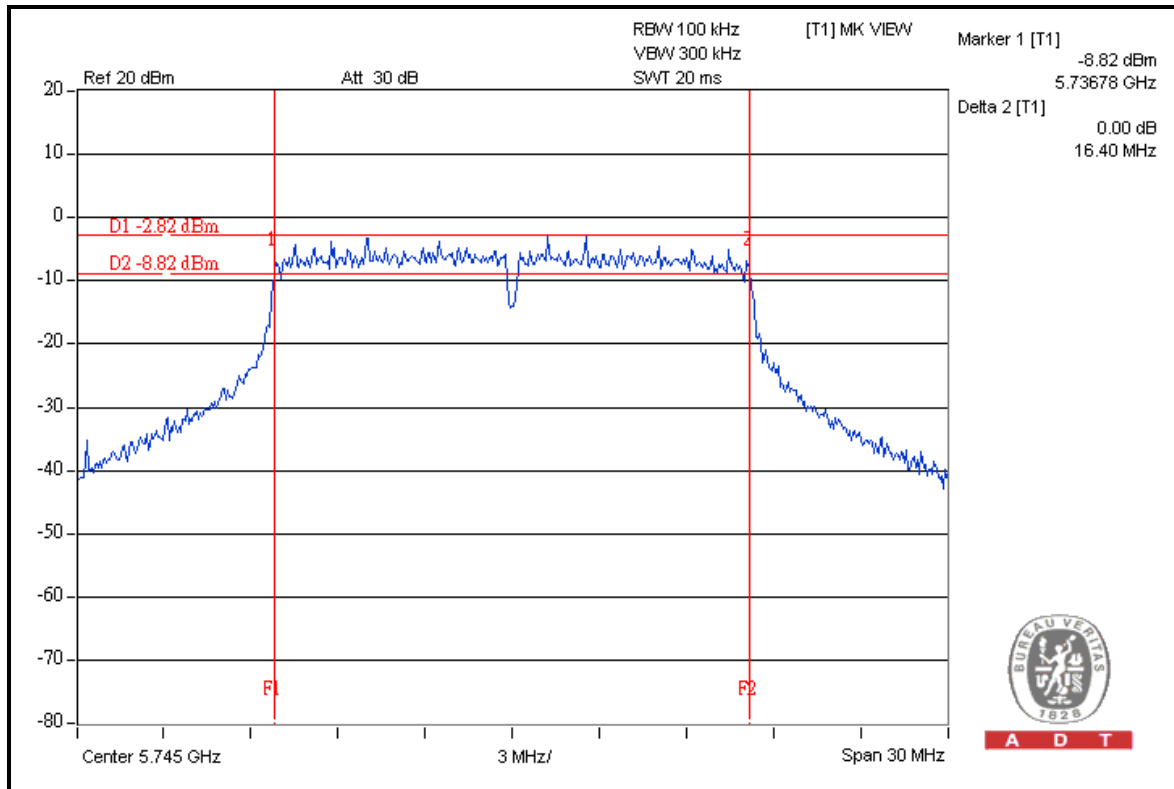

A D T



A D T

CH 157

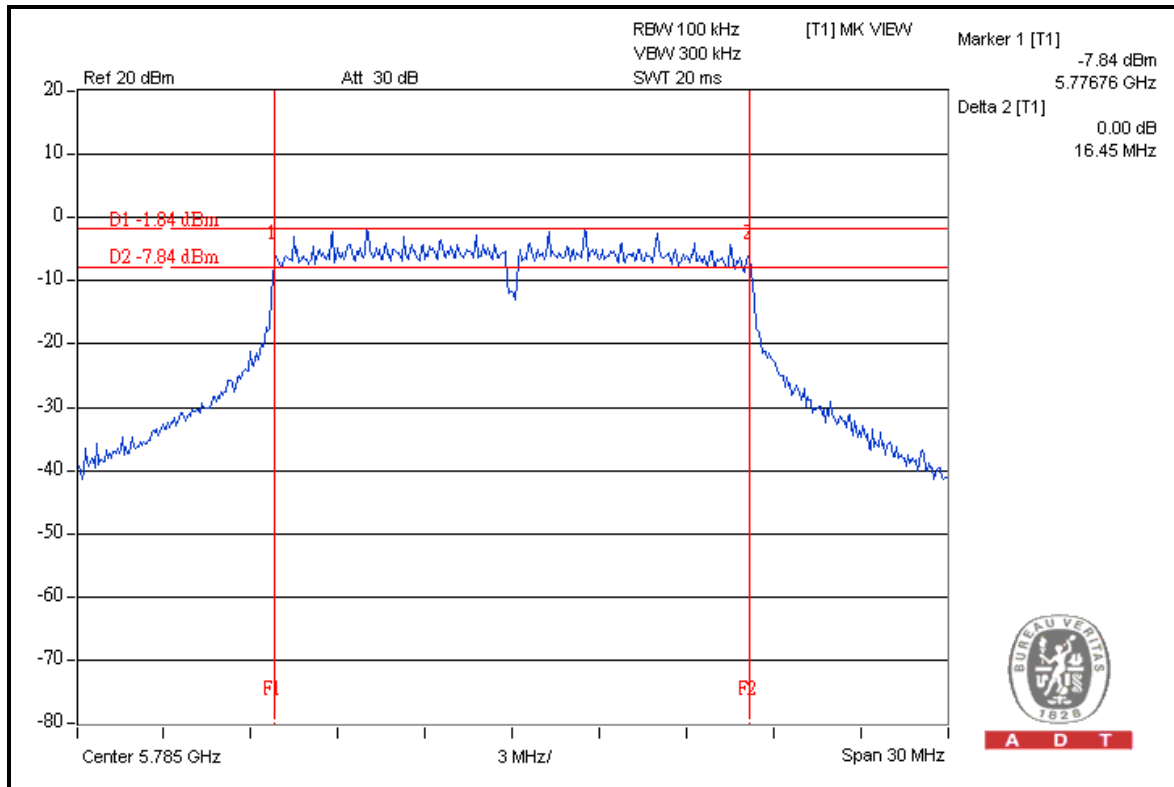

CH 165

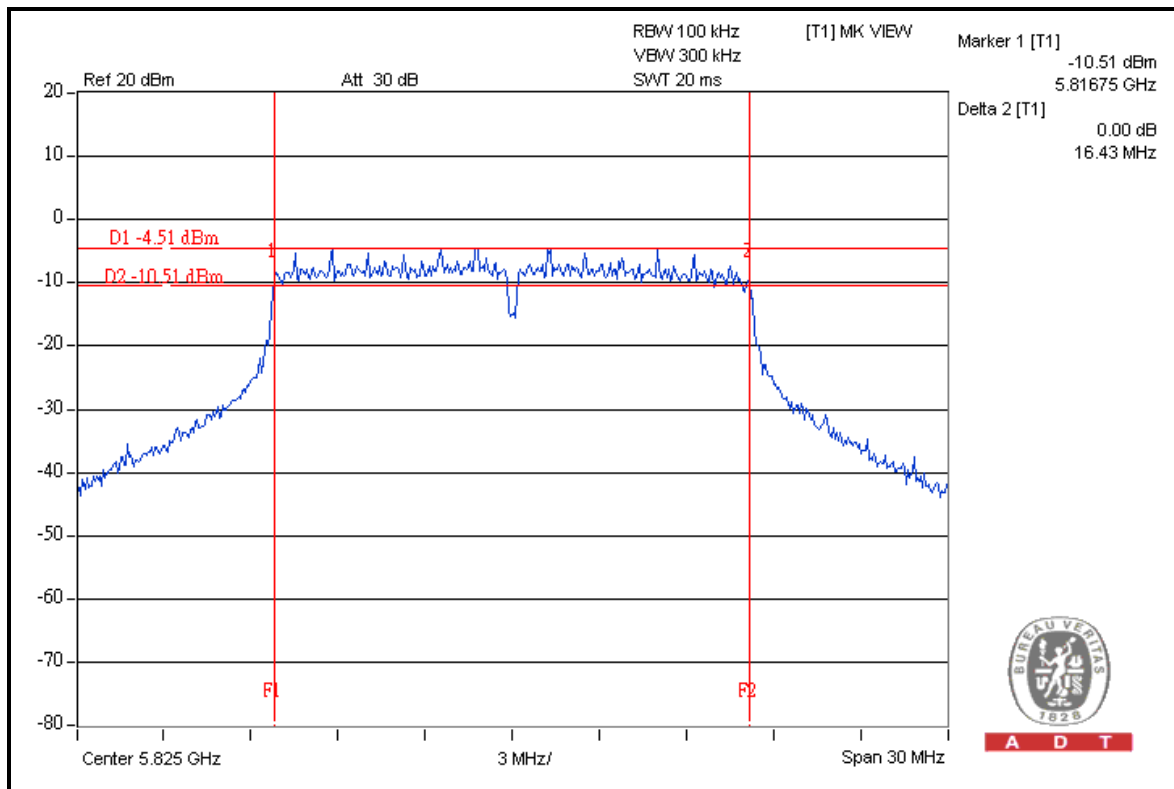



A D T

DRAFT 802.11n (40MHz) OFDM MODULATION

MODULATION TYPE	BPSK	TRANSFER RATE	13.5Mbps
INPUT POWER	120Vac, 60Hz	ENVIRONMENTAL CONDITIONS	25deg.C, 65% RH, 1010hPa
TESTED BY	Chad Lee	TEST MODE	A

CHANNEL	CHANNEL FREQUENCY (MHz)	6dB BANDWIDTH (MHz)		MINIMUM LIMIT (MHz)	PASS / FAIL
		CHAIN 0	CHAIN 1		
151	5755	36.43	36.42	0.5	PASS
159	5795	36.35	36.43	0.5	PASS



A D T

FOR CHAIN 0: CH 151

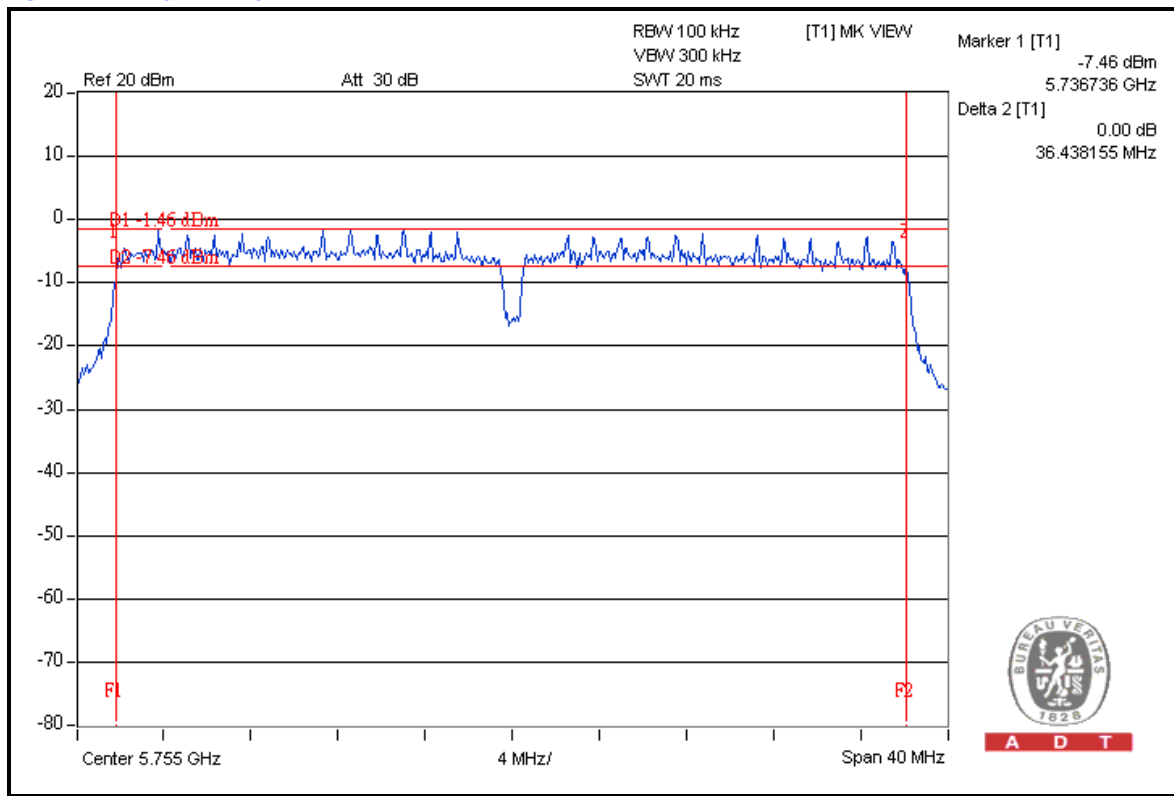

CH 159

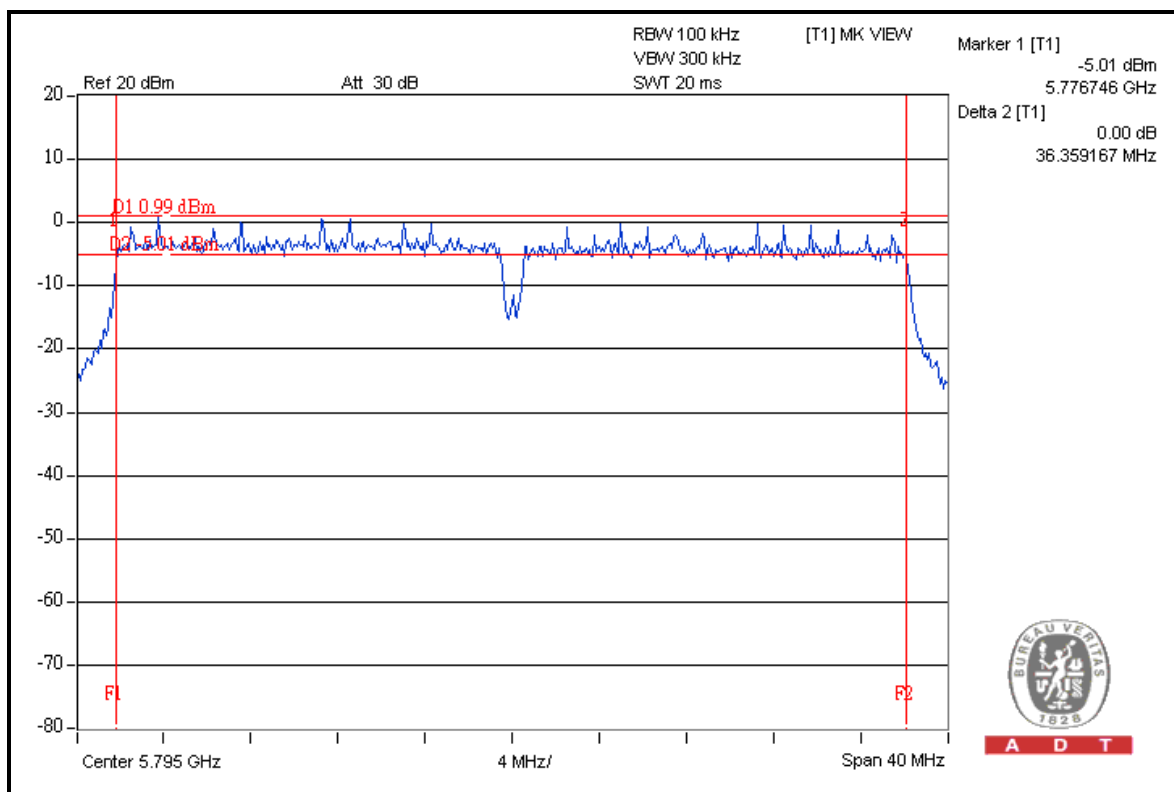



A D T

FOR CHAIN 1: CH 151

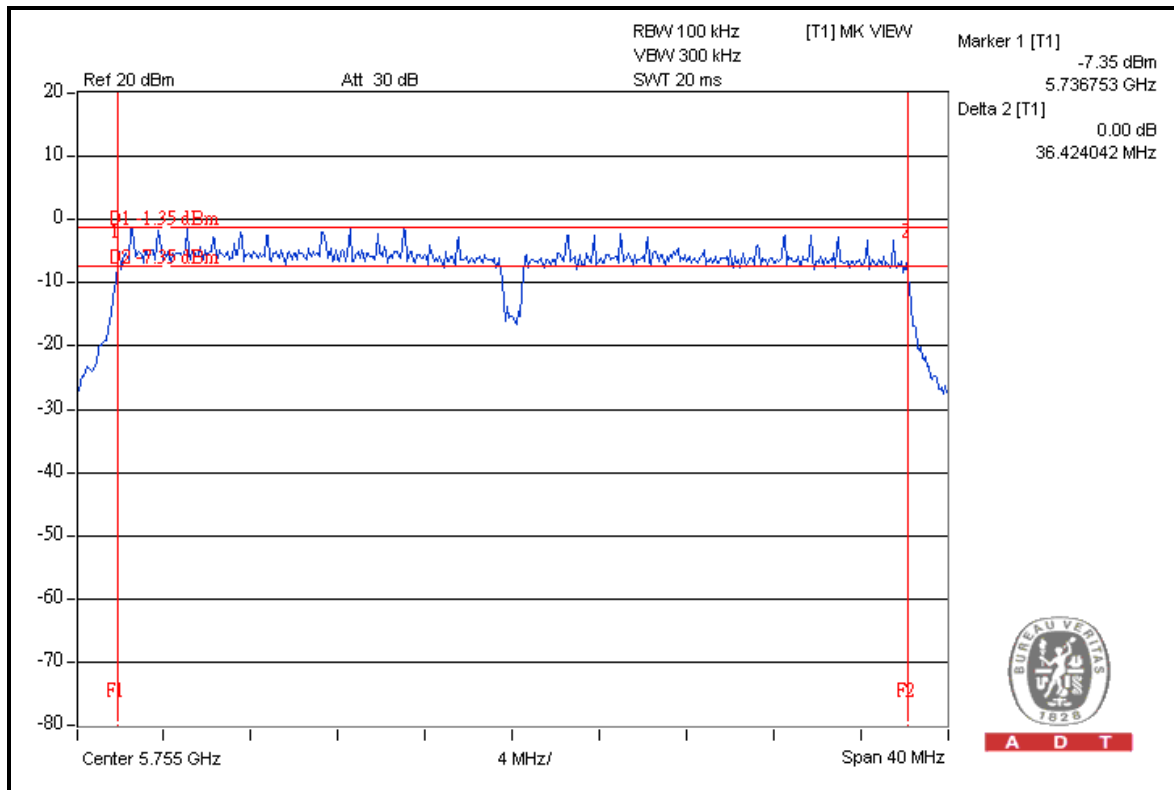

CH 159

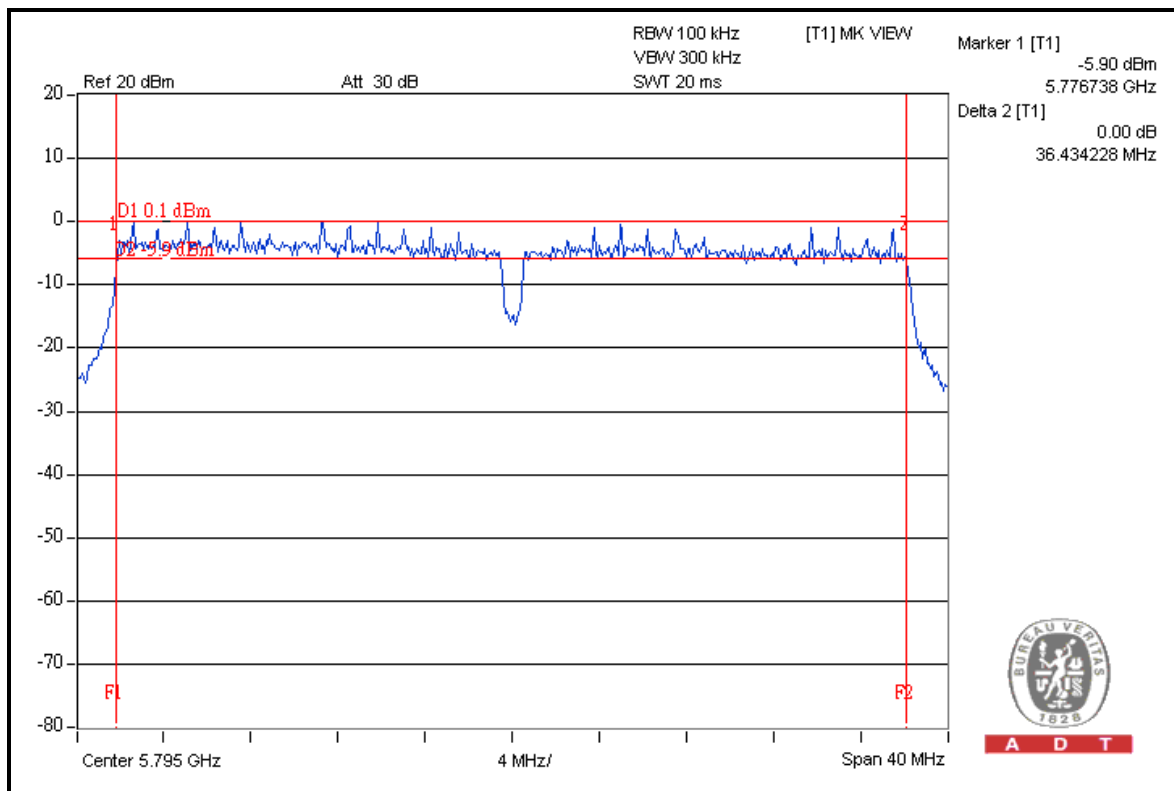



A D T

MODULATION TYPE	BPSK	TRANSFER RATE	13.5Mbps
INPUT POWER	120Vac, 60Hz	ENVIRONMENTAL CONDITIONS	25deg.C, 65% RH, 1010hPa
TESTED BY	Chad Lee	TEST MODE	C

CHANNEL	CHANNEL FREQUENCY (MHz)	6dB BANDWIDTH (MHz)		MINIMUM LIMIT (MHz)	PASS / FAIL
		CHAIN 0	CHAIN 1		
151	5755	36.41	36.46	0.5	PASS
159	5795	36.39	36.48	0.5	PASS



A D T

FOR CHAIN 0: CH 151

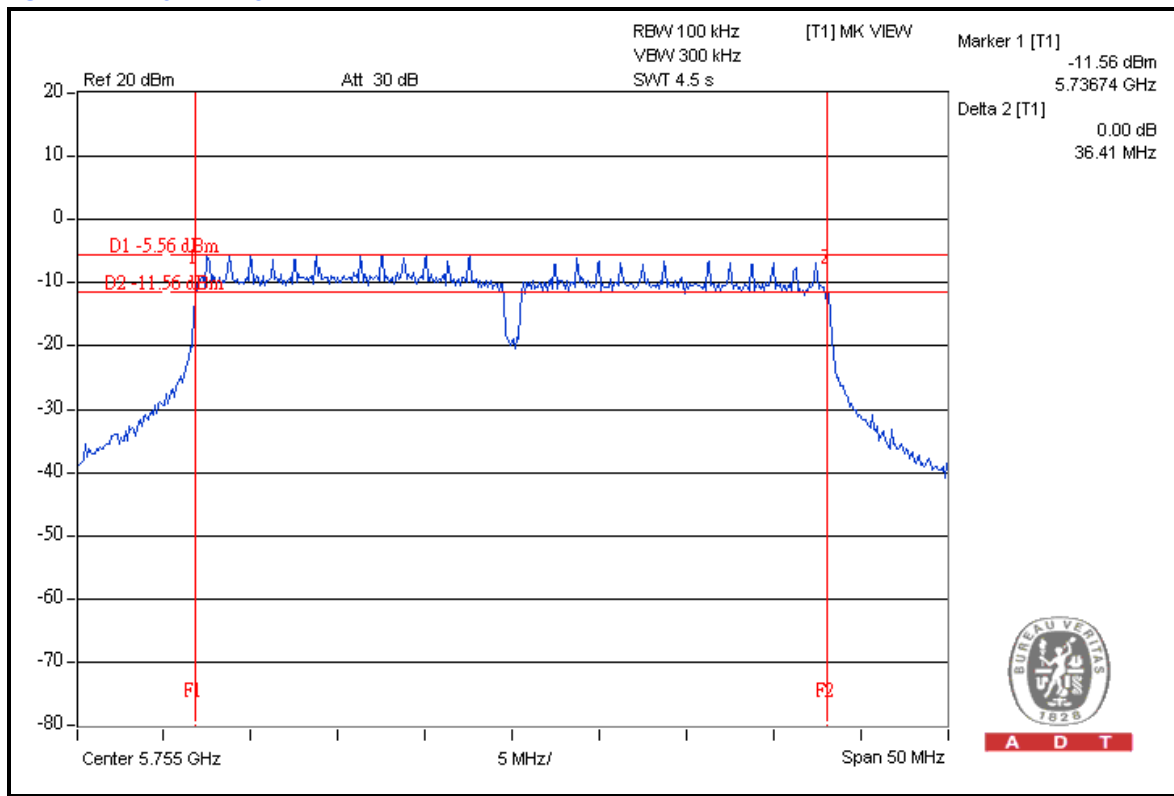

CH 159

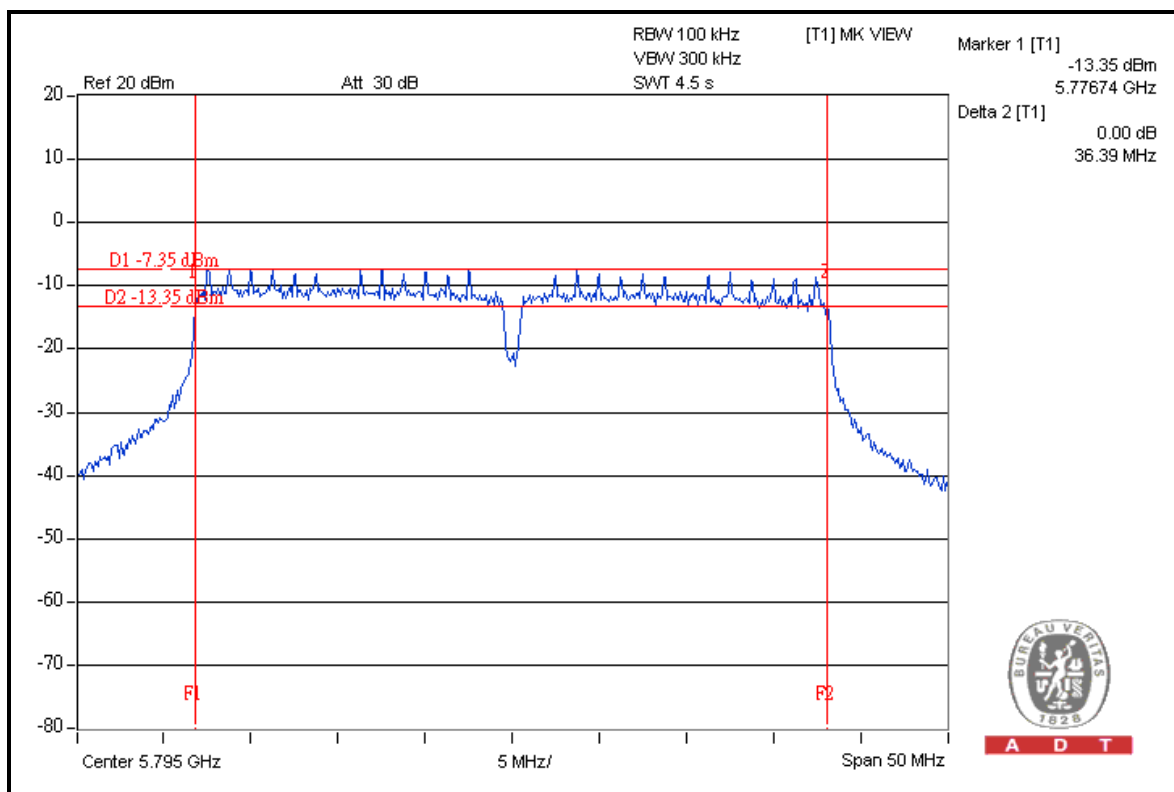



A D T

FOR CHAIN 1: CH 151

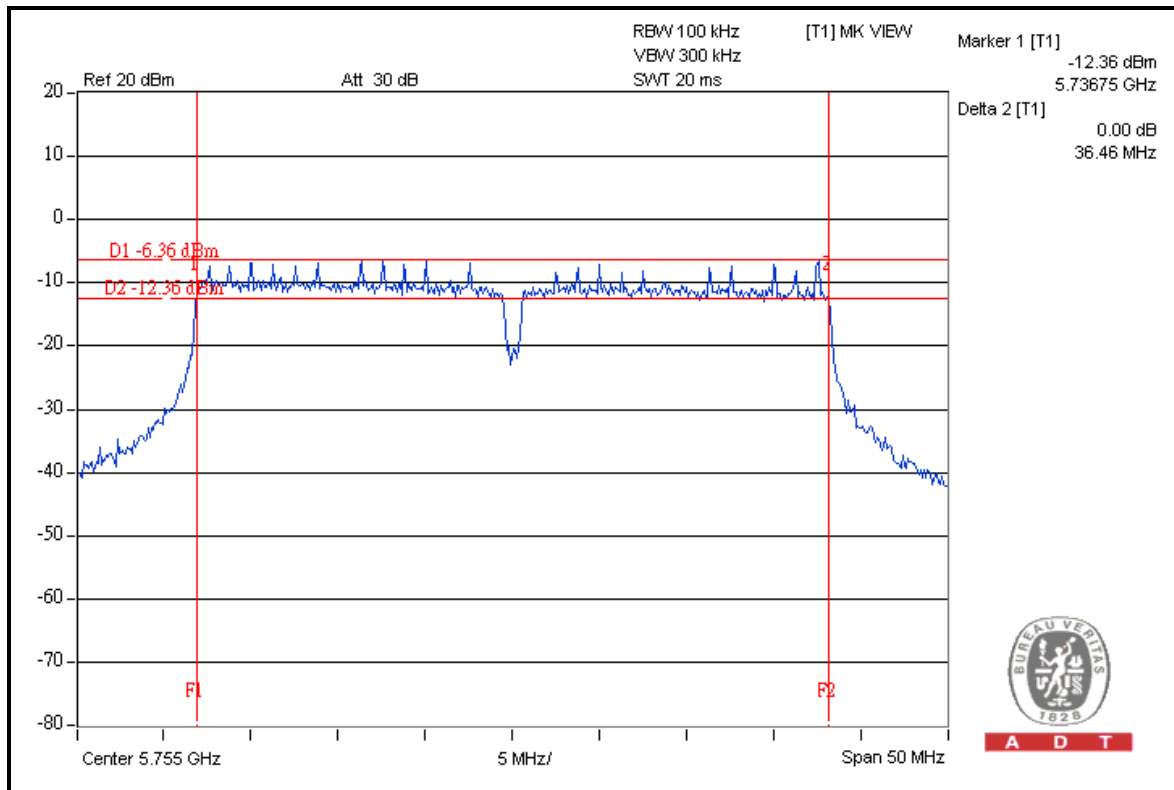

CH 159

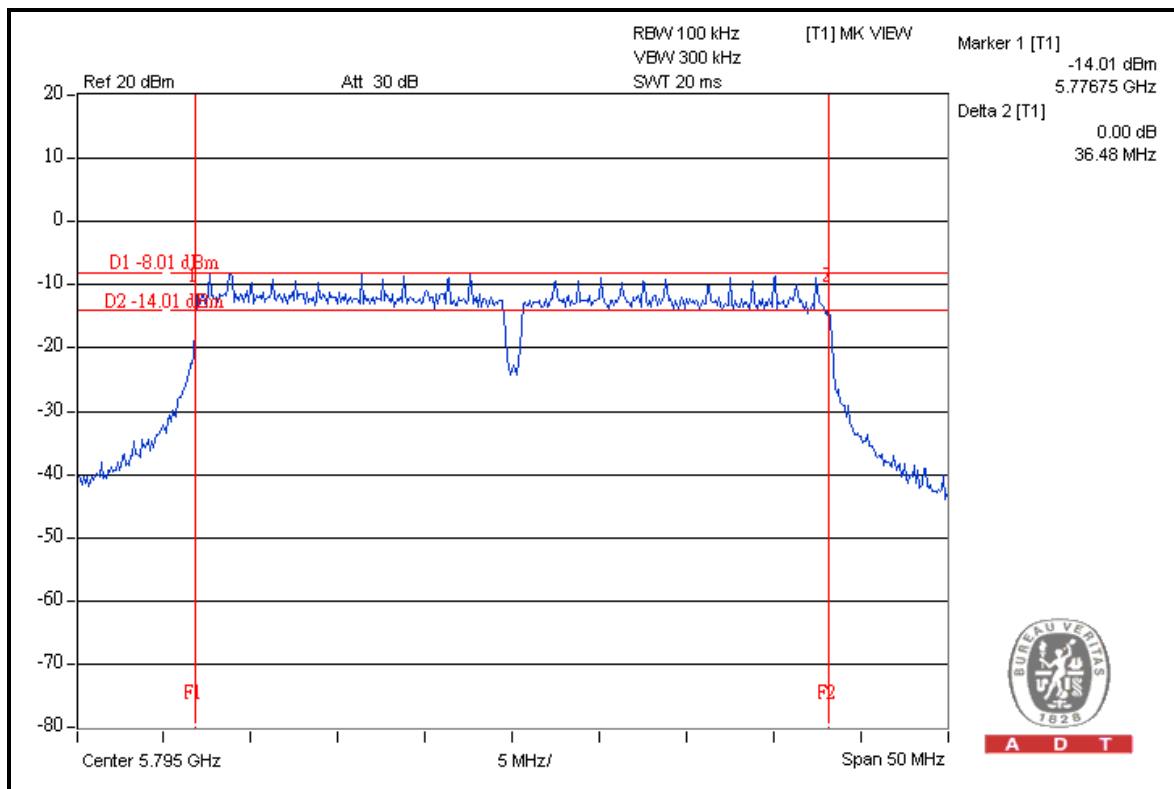



A D T

4.4 MAXIMUM PEAK OUTPUT POWER

4.4.1 LIMITS OF MAXIMUM PEAK OUTPUT POWER MEASUREMENT

The Maximum Peak Output Power Measurement is 30dBm.

4.4.2 INSTRUMENTS

DESCRIPTION & MANUFACTURER	MODEL NO.	SERIAL NO.	DATE OF CALIBRATION	DUE DATE OF CALIBRATION
Agilent SPECTRUM ANALYZER	E4446A	MY46180403	June 22, 2009	June 21, 2010

Note: The calibration interval of the above test instruments is 12 months and the calibrations are traceable to NML/ROC and NIST/USA.

4.4.3 TEST PROCEDURES

1. Follow DTS measurement (Power Output Option 2), the transmitter output was connected to the spectrum analyzer through an attenuator, the bandwidth of the fundamental frequency was measured with the spectrum analyzer.
2. Set span to encompass the entire emission bandwidth (EBW) of the signal.
3. Set RBW = 1 MHz ; VBW \geq 3 MHz.
4. Use sample detector mode and video trigger with the trigger level set to enable triggering only on full power pulses.
5. Trace average 100 traces in power averaging mode.
6. Compute power by integrating the spectrum across the 26 dB EBW of the signal.
7. Record the power level.



4.4.4 DEVIATION FROM TEST STANDARD

No deviation.

4.4.5 TEST SETUP

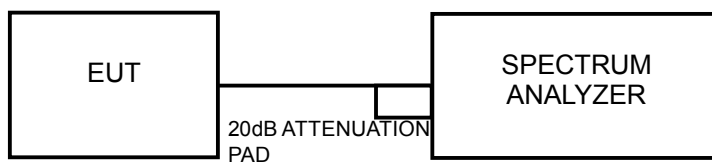

4.4.6 EUT OPERATING CONDITIONS

Same as Item 4.3.6



A D T

4.4.7 TEST RESULTS

802.11a OFDM MODULATION

MODULATION TYPE	BPSK	TRANSFER RATE	6.0Mbps
INPUT POWER	120Vac, 60Hz	ENVIRONMENTAL CONDITIONS	25deg.C, 65% RH, 1010hPa
TESTED BY	Chad Lee	TEST MODE	A

CHAN.	CHAN. FREQ. (MHz)	PEAK POWER OUTPUT (dBm)		TOTAL PEAK POWER (mW)	TOTAL PEAK POWER (dBm)	PEAK POWER LIMIT (dBm)	PASS / FAIL
		CHAIN 0	CHAIN 1				
149	5745	12.83	12.43	36.685	15.64	22	PASS
157	5785	16.12	16.10	81.664	19.12	22	PASS
165	5825	12.48	12.42	35.159	15.46	22	PASS



A D T

FOR CHAIN 0: CH 149

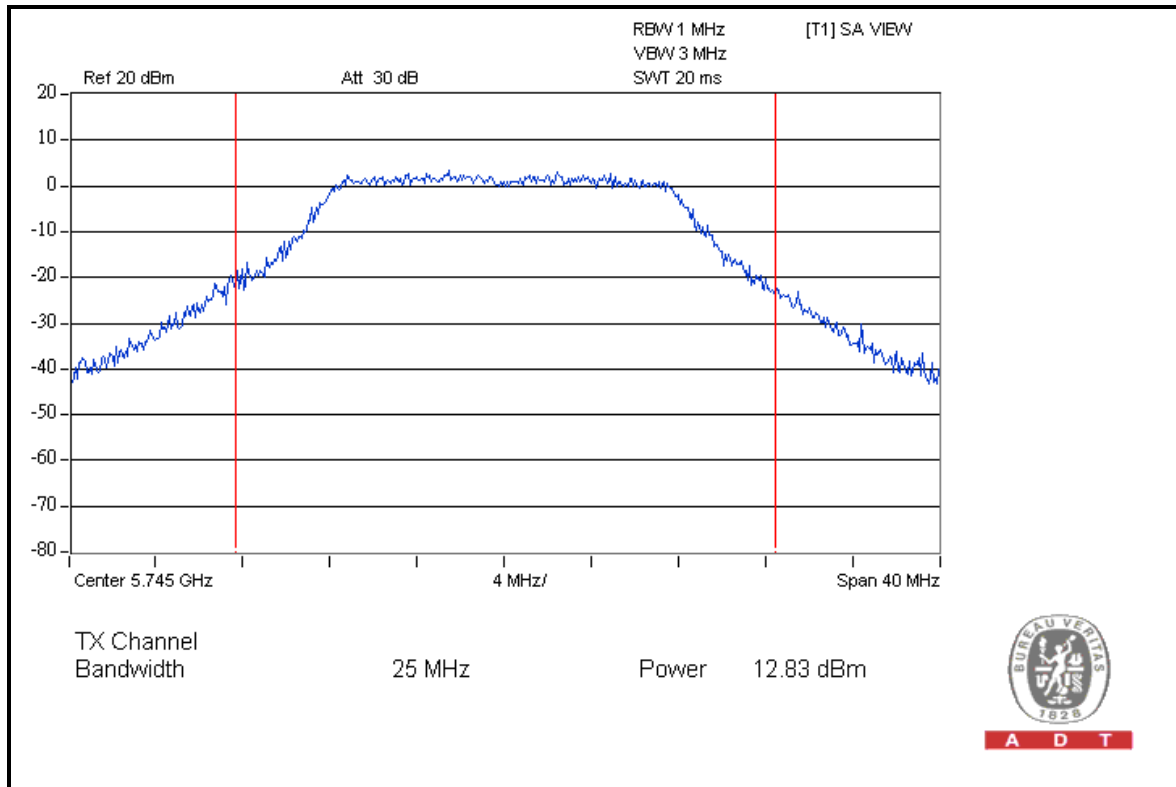

CH 157

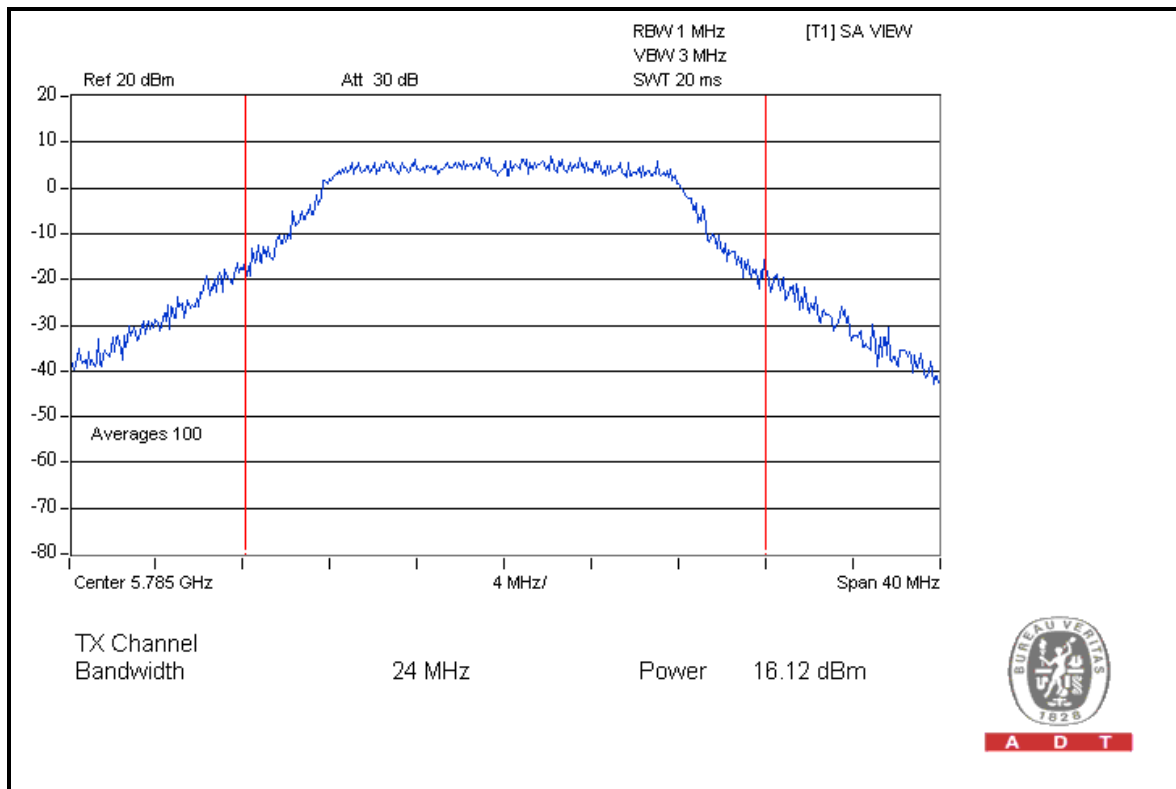



A D T

CH 165

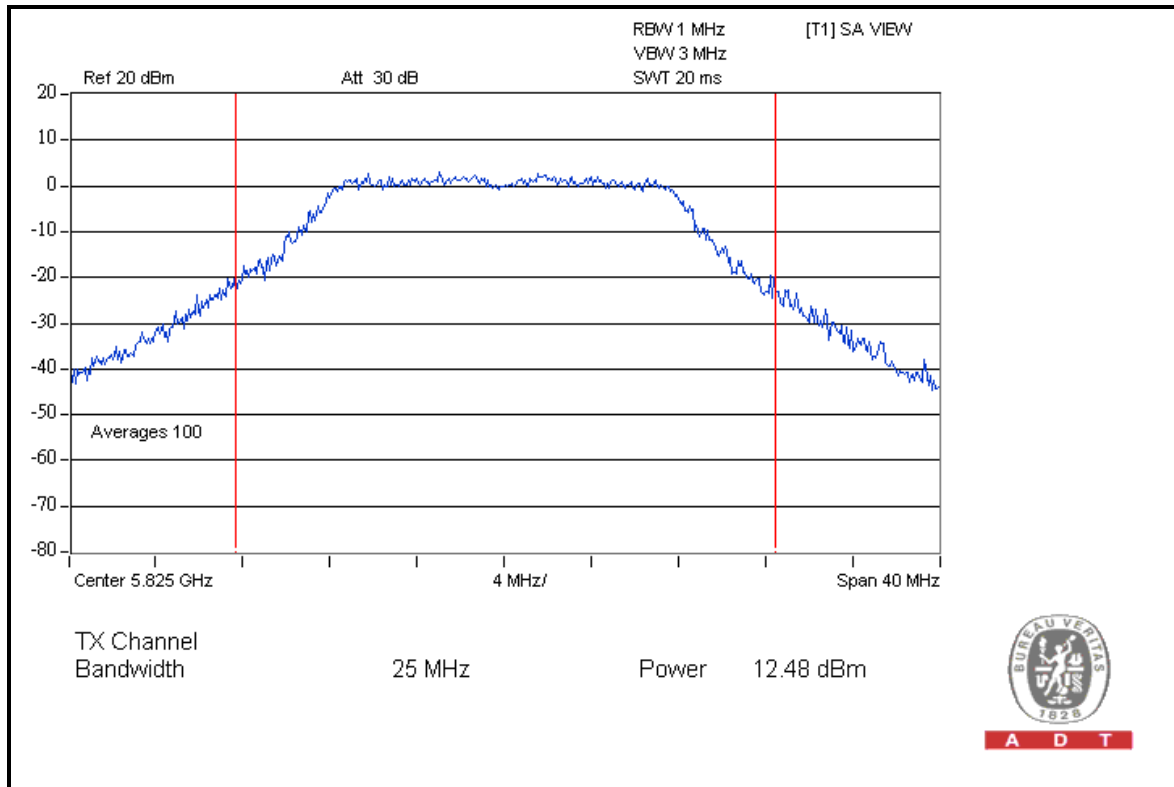

FOR CHAIN 1: CH 149

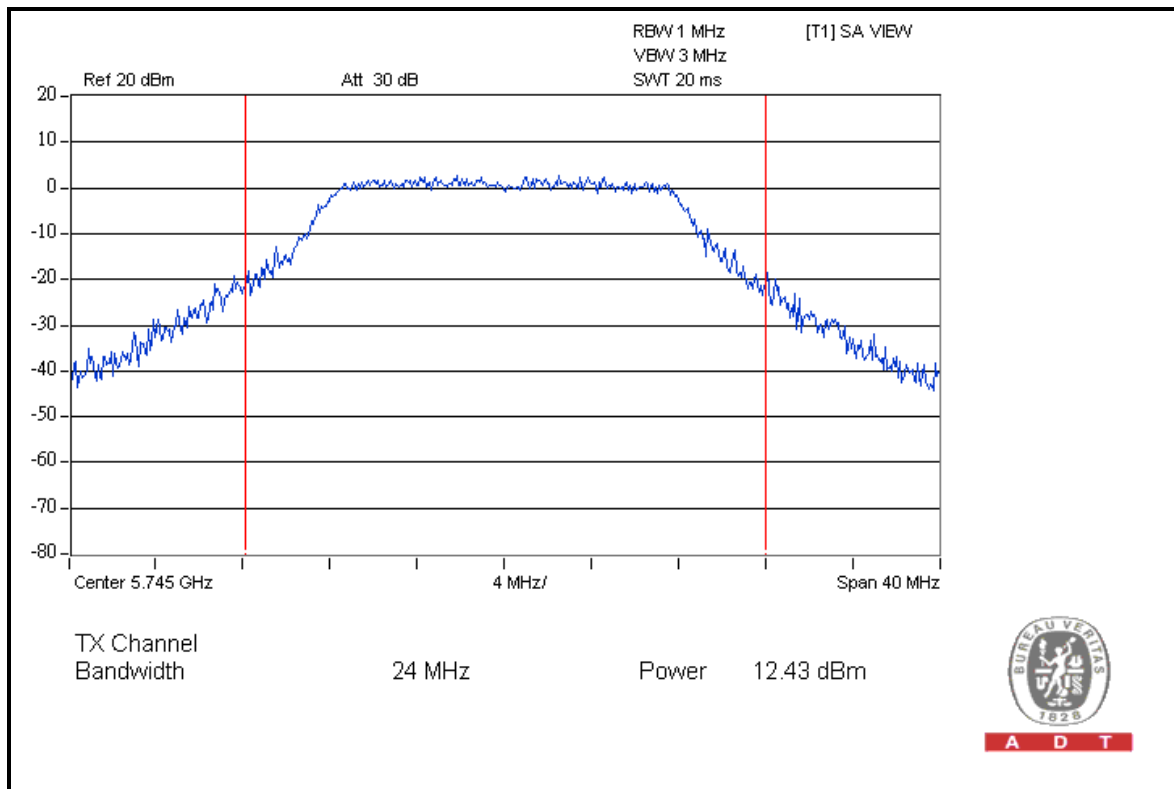



A D T

CH 157

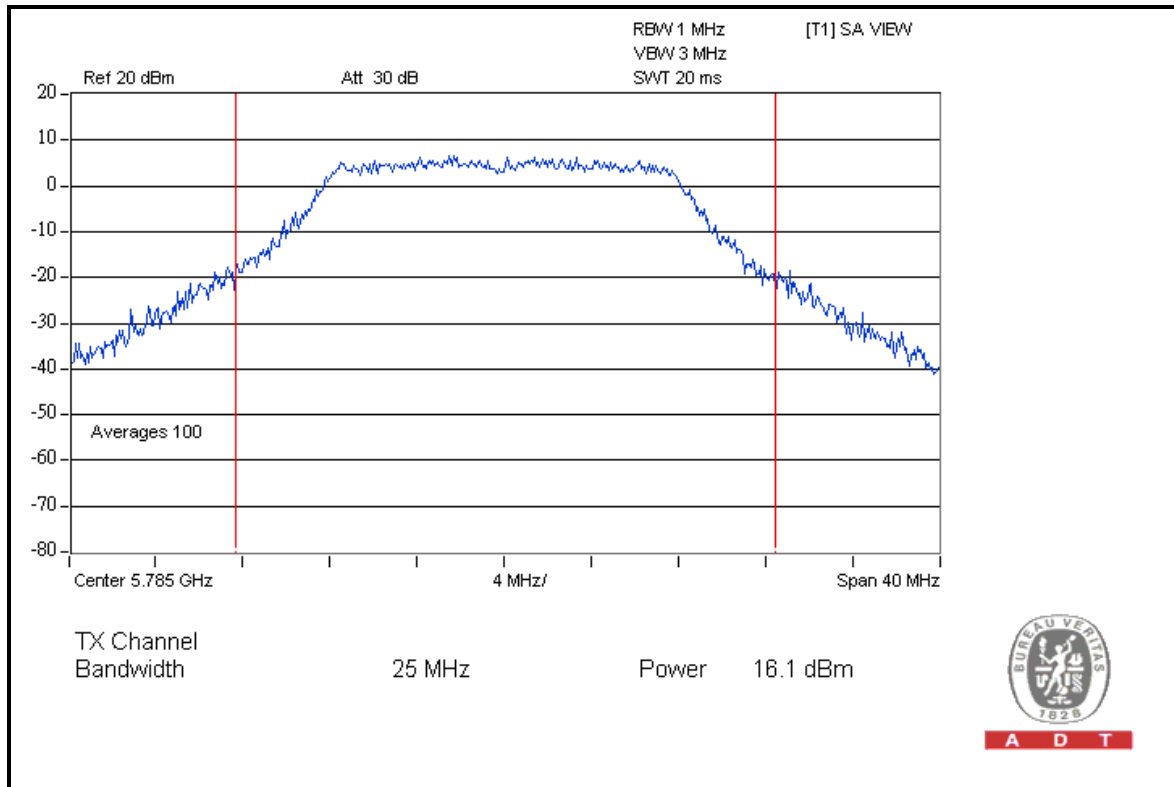

CH 165

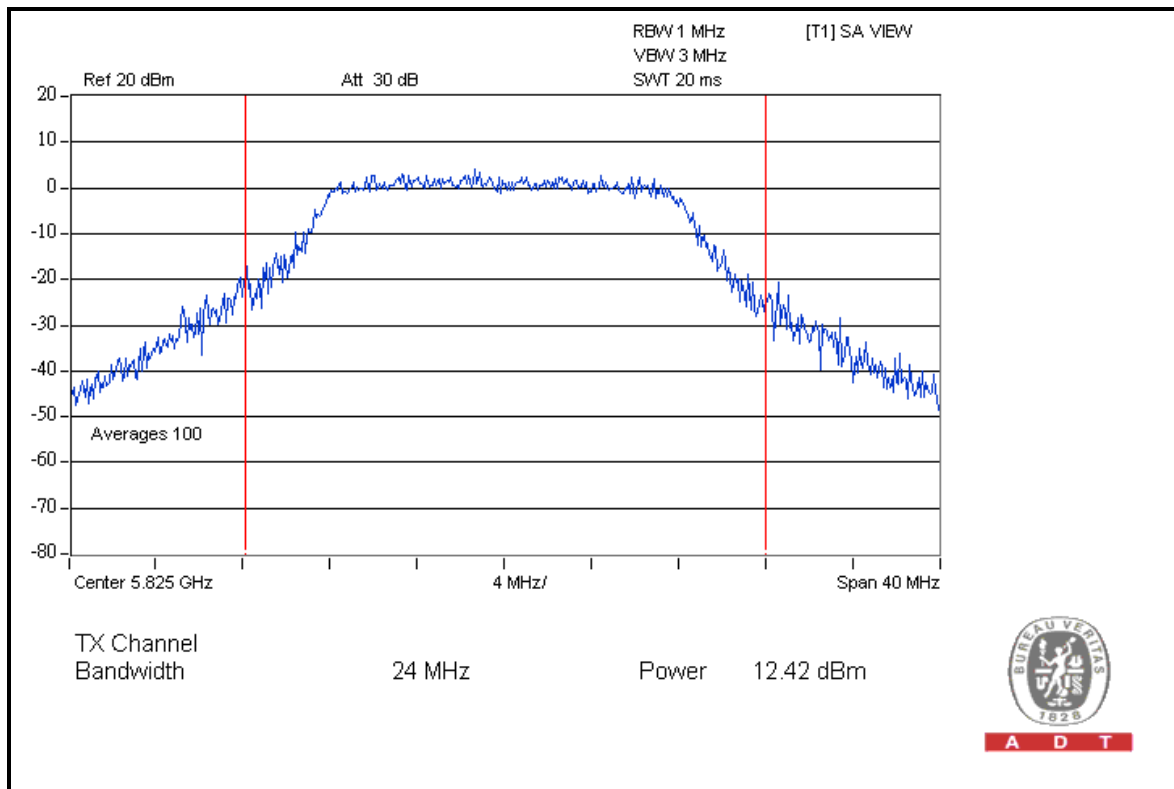



A D T

MODULATION TYPE	BPSK	TRANSFER RATE	6.0Mbps
INPUT POWER	120Vac, 60Hz	ENVIRONMENTAL CONDITIONS	25deg.C, 65% RH, 1010hPa
TESTED BY	Chad Lee	TEST MODE	C

CHAN.	CHAN. FREQ. (MHz)	PEAK POWER OUTPUT (dBm)		TOTAL PEAK POWER (mW)	TOTAL PEAK POWER (dBm)	PEAK POWER LIMIT (dBm)	PASS / FAIL
		CHAIN 0	CHAIN 1				
149	5745	9.42	9.00	16.693	12.23	13	PASS
157	5785	9.82	9.77	19.078	12.81	13	PASS
165	5825	8.71	8.29	14.175	11.52	13	PASS



A D T

FOR CHAIN 0: CH 149

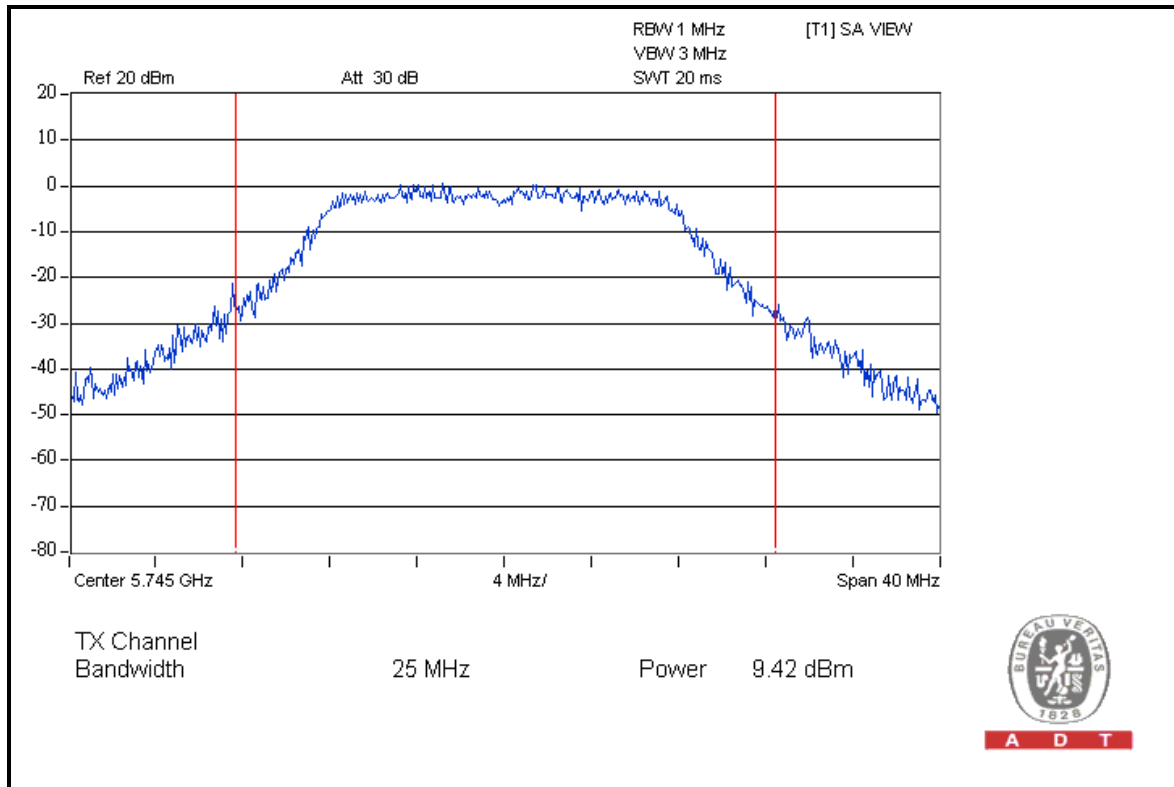

CH 157

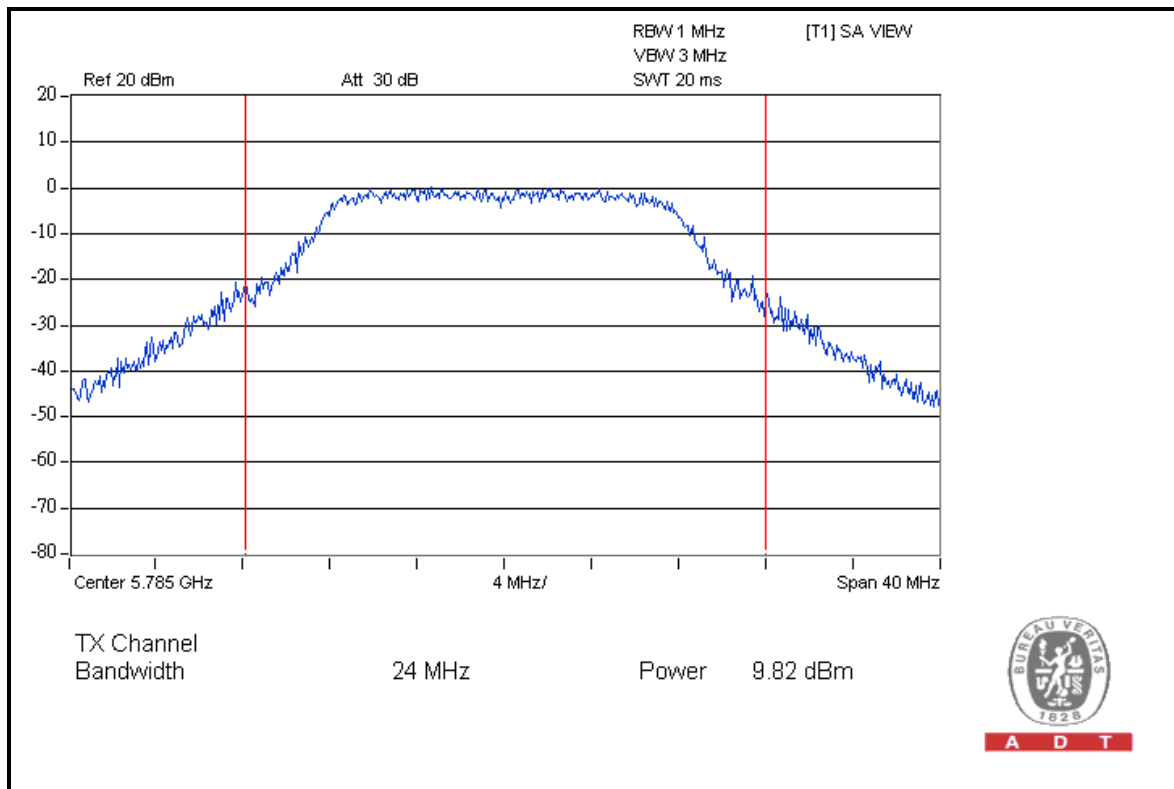



A D T

CH 165

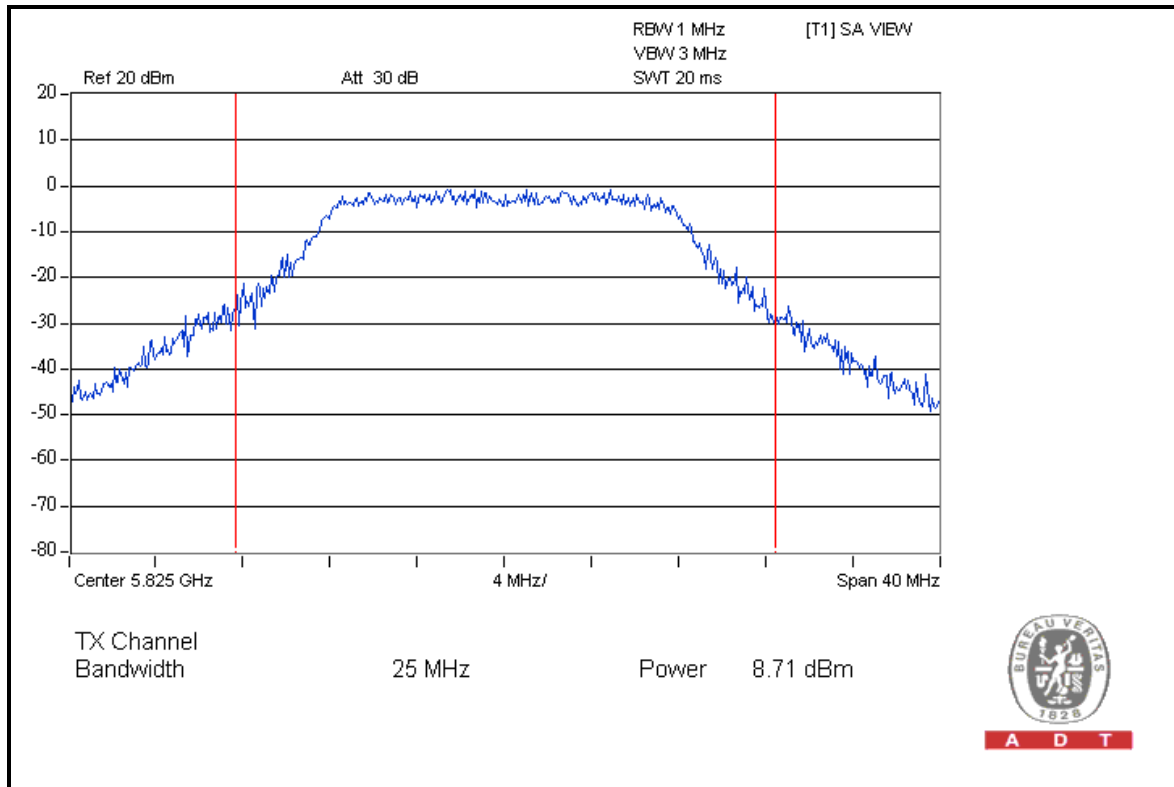

FOR CHAIN 1: CH 149

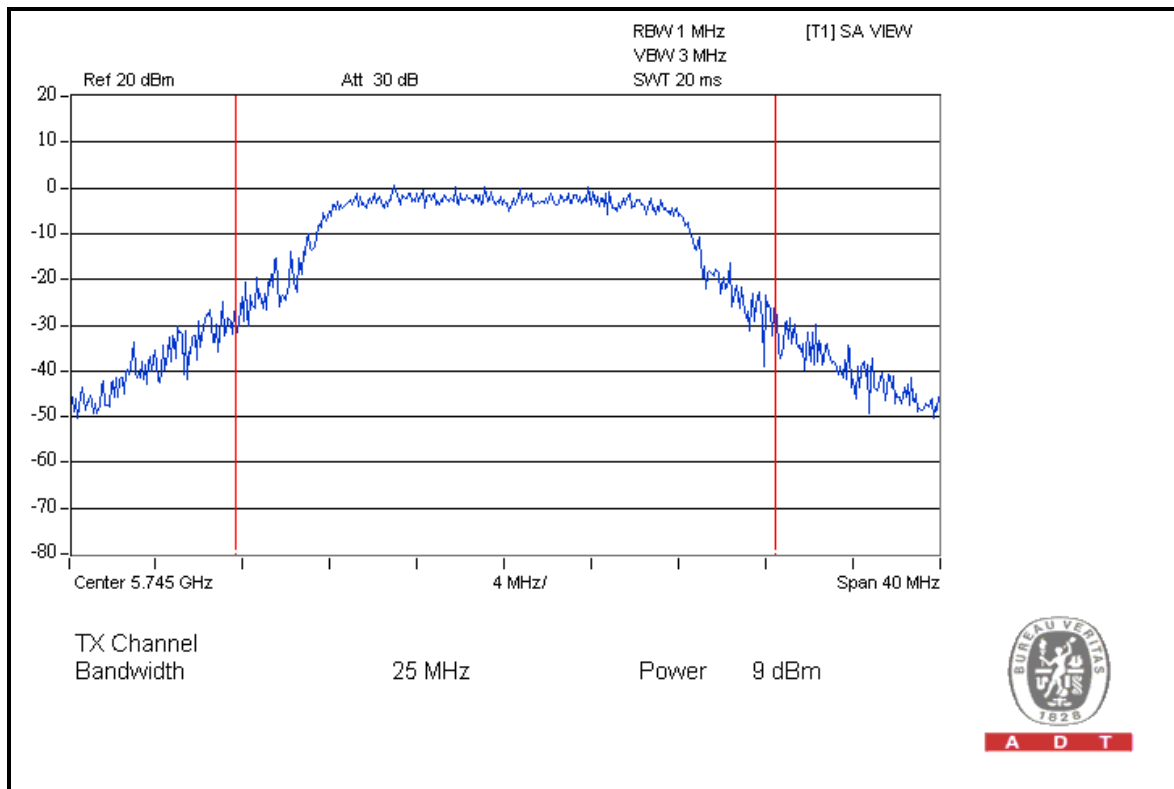



A D T

CH 157

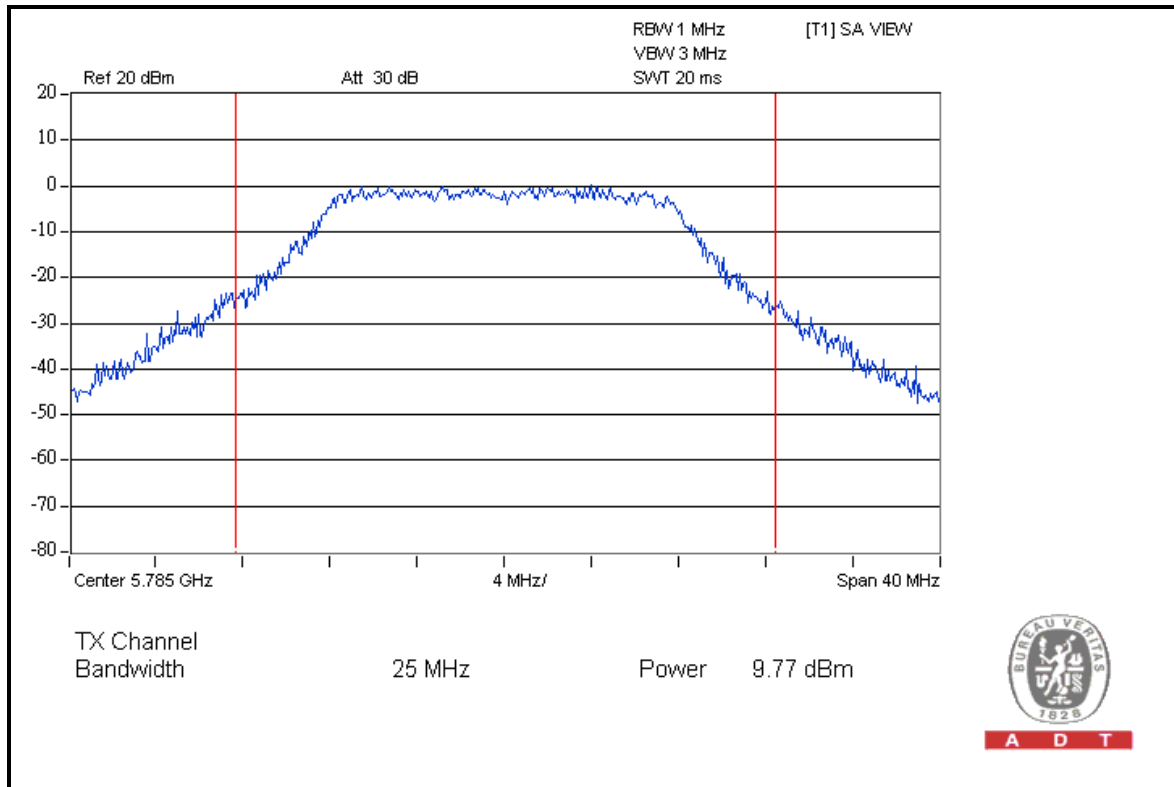

CH 165

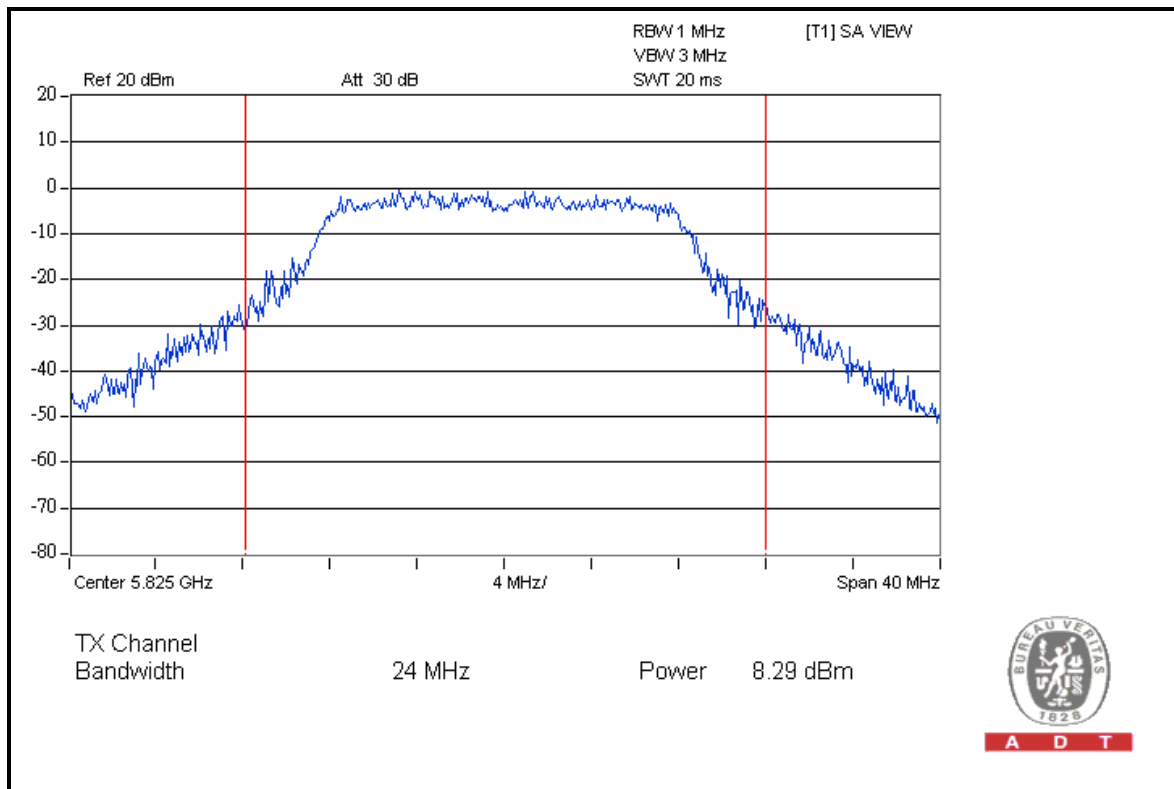



A D T

DRAFT 802.11n (20MHz) OFDM MODULATION

MODULATION TYPE	BPSK	TRANSFER RATE	6.5Mbps
INPUT POWER	120Vac, 60Hz	ENVIRONMENTAL CONDITIONS	25deg.C, 65% RH, 1010hPa
TESTED BY	Chad Lee	TEST MODE	A

CHAN.	CHAN. FREQ. (MHz)	PEAK POWER OUTPUT (dBm)		TOTAL PEAK POWER (mW)	TOTAL PEAK POWER (dBm)	PEAK POWER LIMIT (dBm)	PASS / FAIL
		CHAIN 0	CHAIN 1				
149	5745	12.85	12.44	36.814	15.66	22	PASS
157	5785	16.17	16.13	82.420	19.16	22	PASS
165	5825	12.50	12.46	35.403	15.49	22	PASS



A D T

FOR CHAIN 0: CH 149

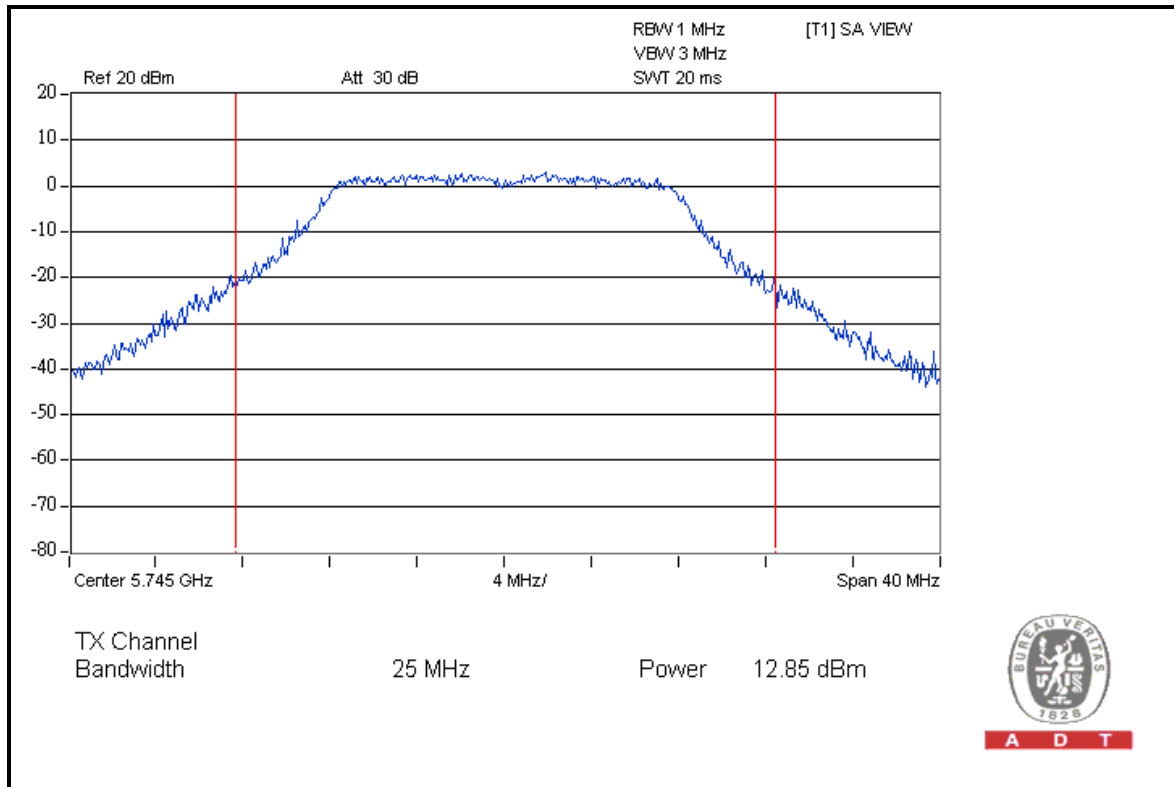

CH 157

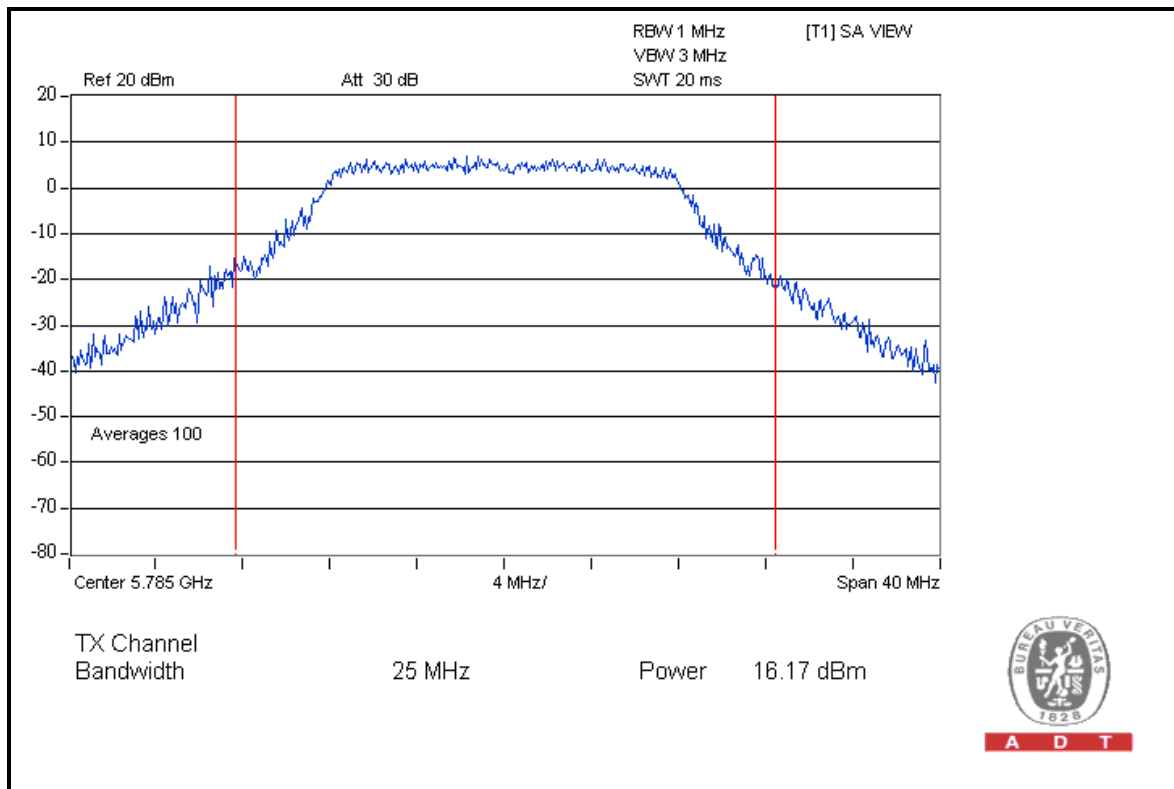



A D T

CH 165

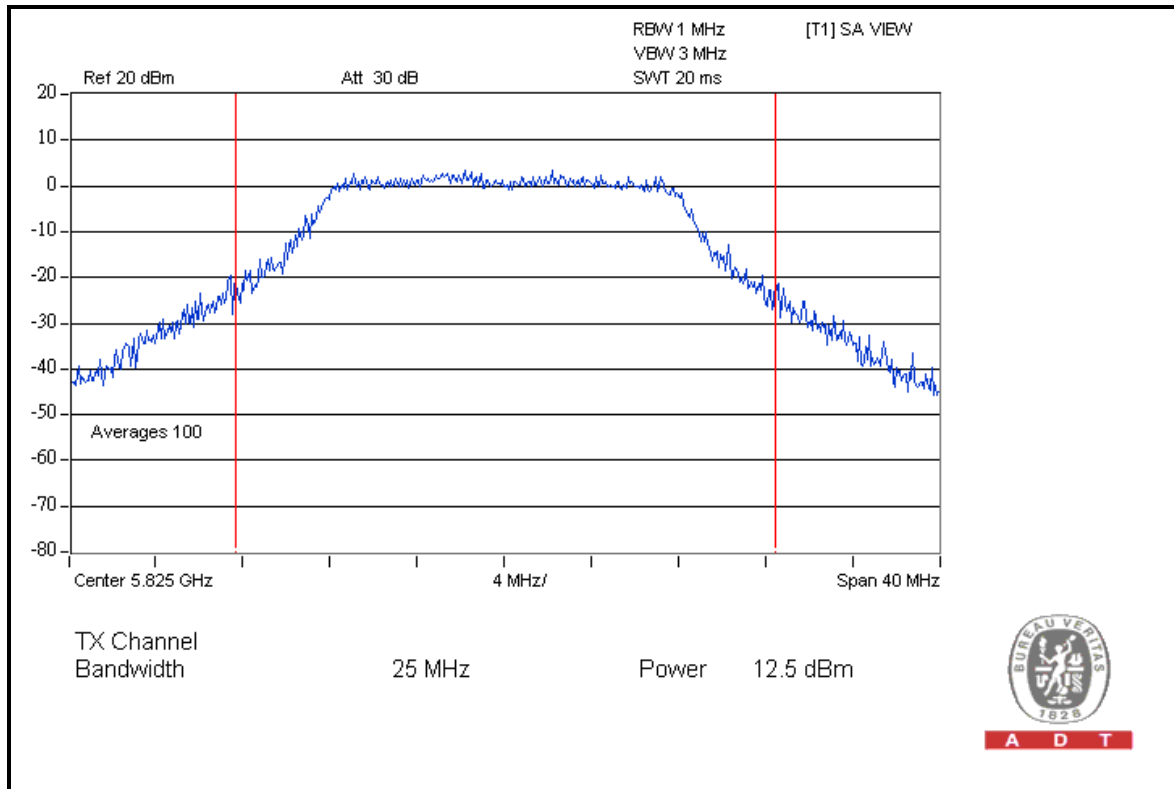

A D T

FOR CHAIN 1: CH 149

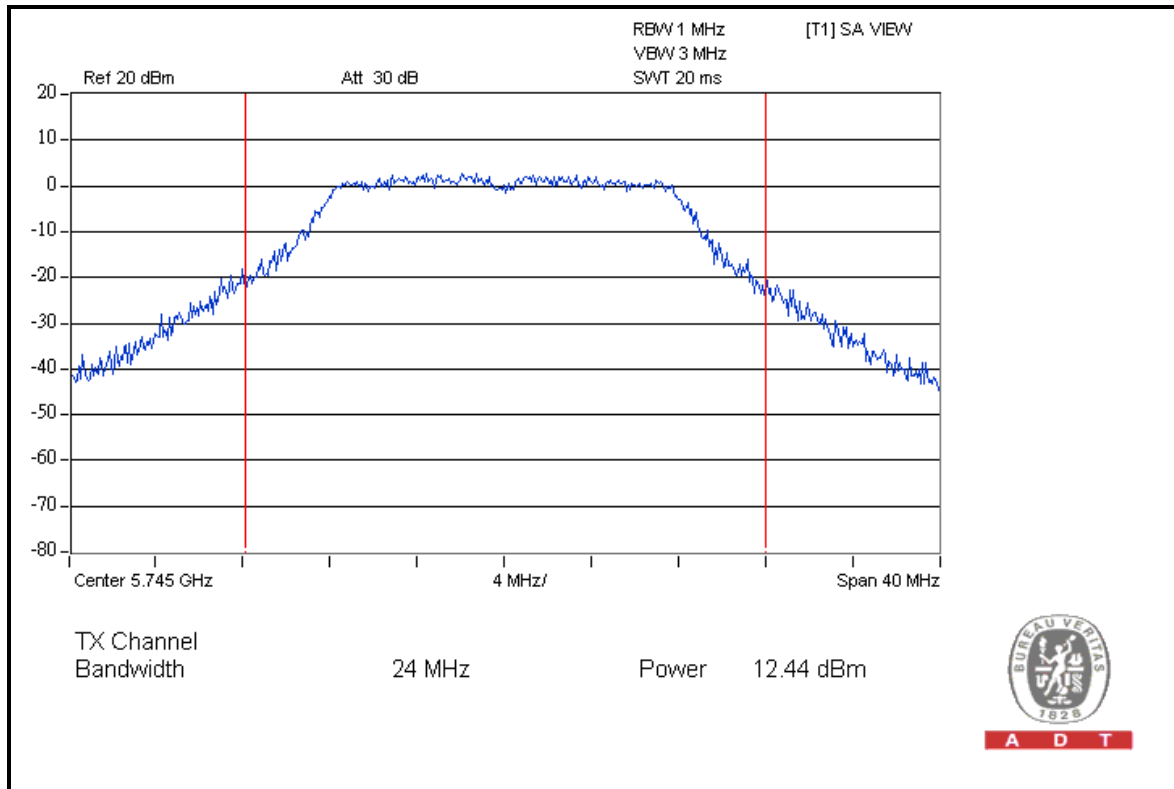

A D T



A D T

CH 157

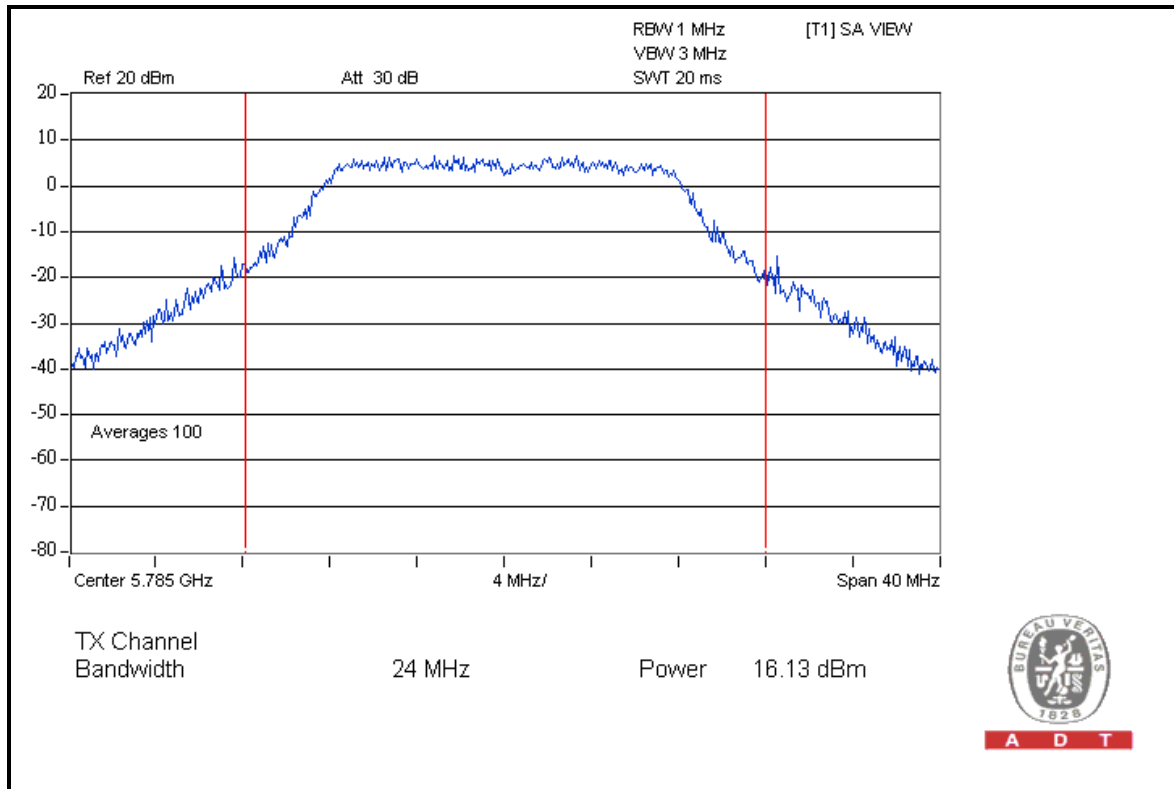

A D T

CH 165

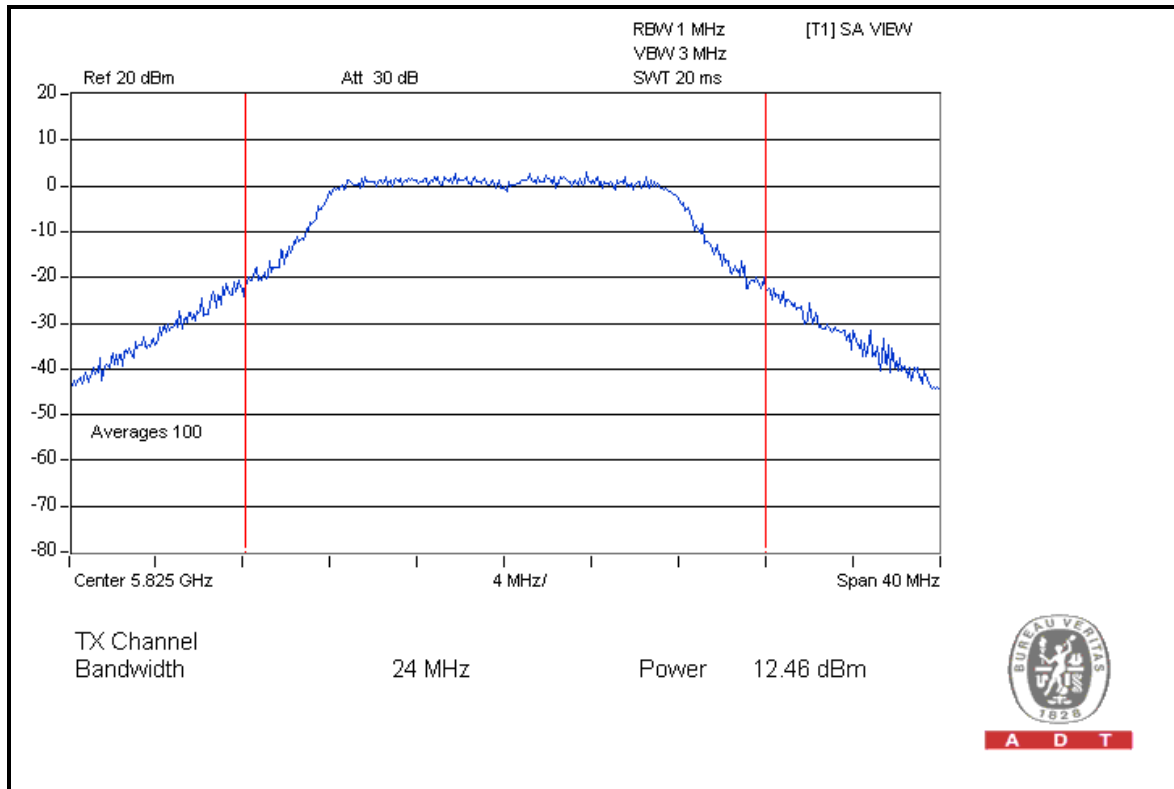

A D T



A D T

MODULATION TYPE	BPSK	TRANSFER RATE	6.5Mbps
INPUT POWER	120Vac, 60Hz	ENVIRONMENTAL CONDITIONS	25deg.C, 65% RH, 1010hPa
TESTED BY	Chad Lee	TEST MODE	C

CHAN.	CHAN. FREQ. (MHz)	PEAK POWER OUTPUT (dBm)		TOTAL PEAK POWER (mW)	TOTAL PEAK POWER (dBm)	PEAK POWER LIMIT (dBm)	PASS / FAIL
		CHAIN 0	CHAIN 1				
149	5745	9.74	9.14	17.622	12.46	13	PASS
157	5785	9.90	9.81	19.344	12.87	13	PASS
165	5825	8.75	8.38	14.384	11.58	13	PASS



A D T

FOR CHAIN 0: CH 149

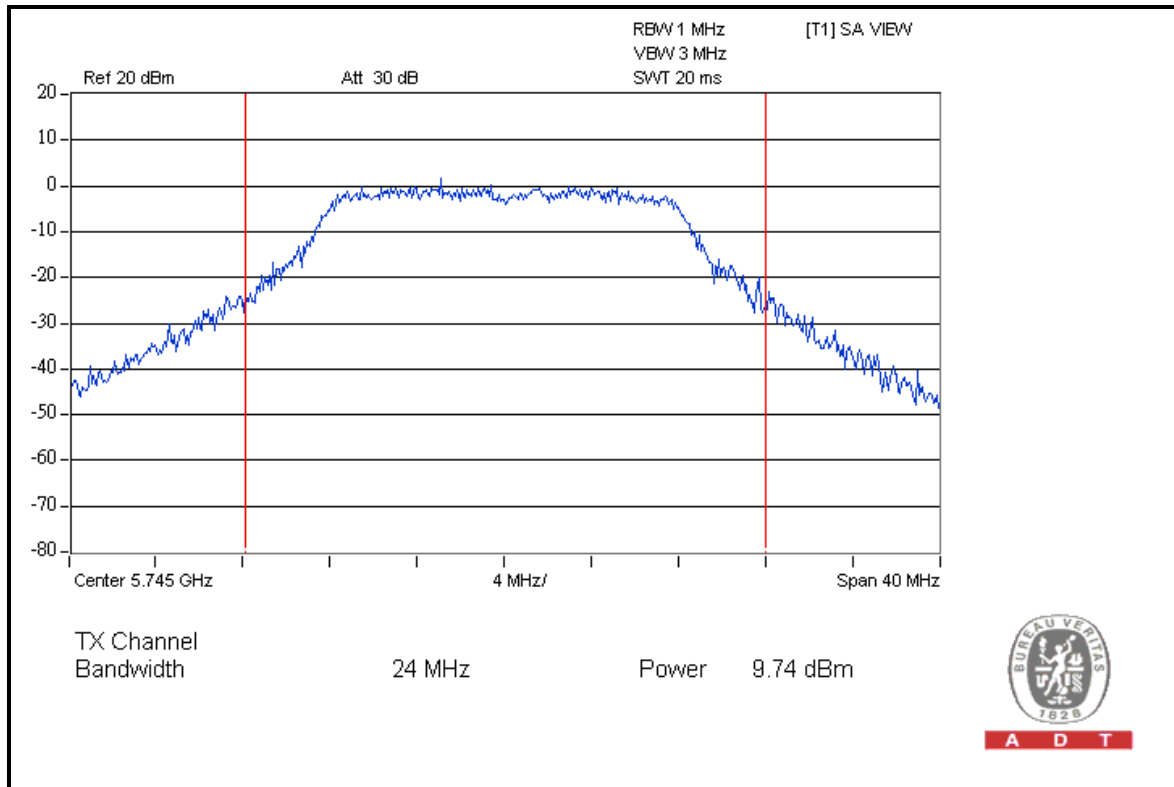

CH 157

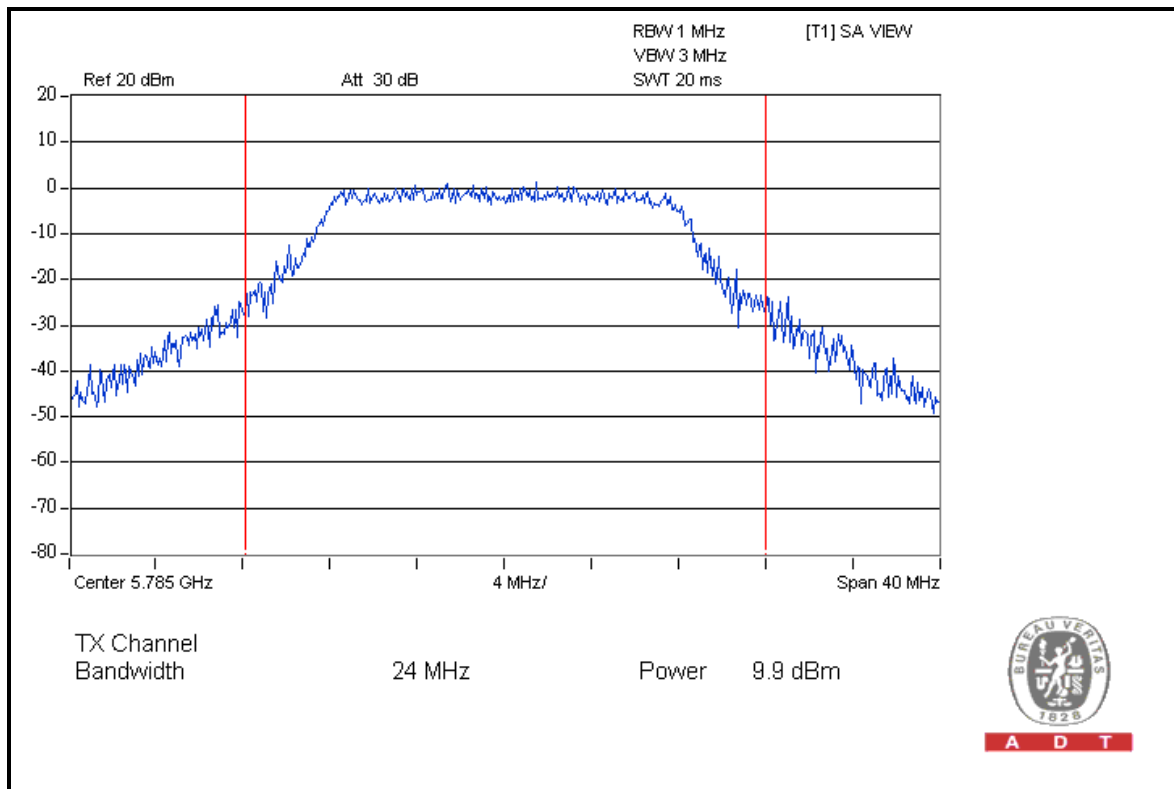



A D T

CH 165

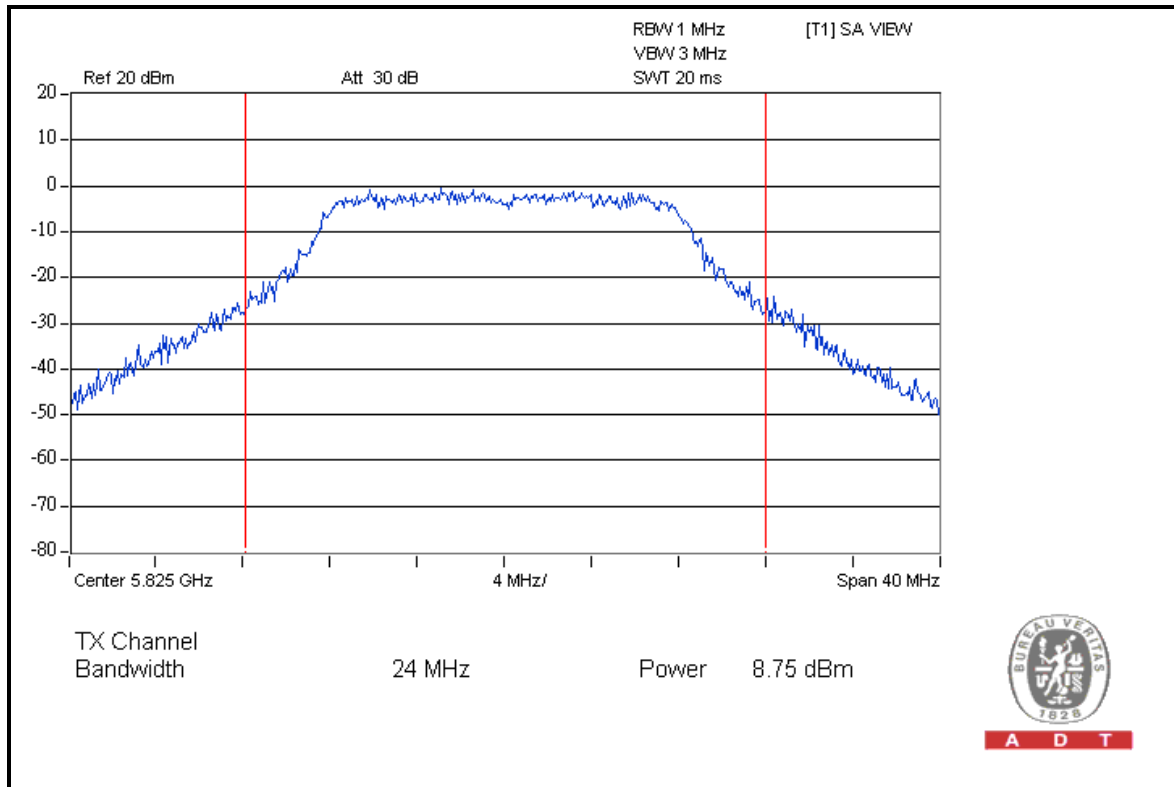

FOR CHAIN 1: CH 149

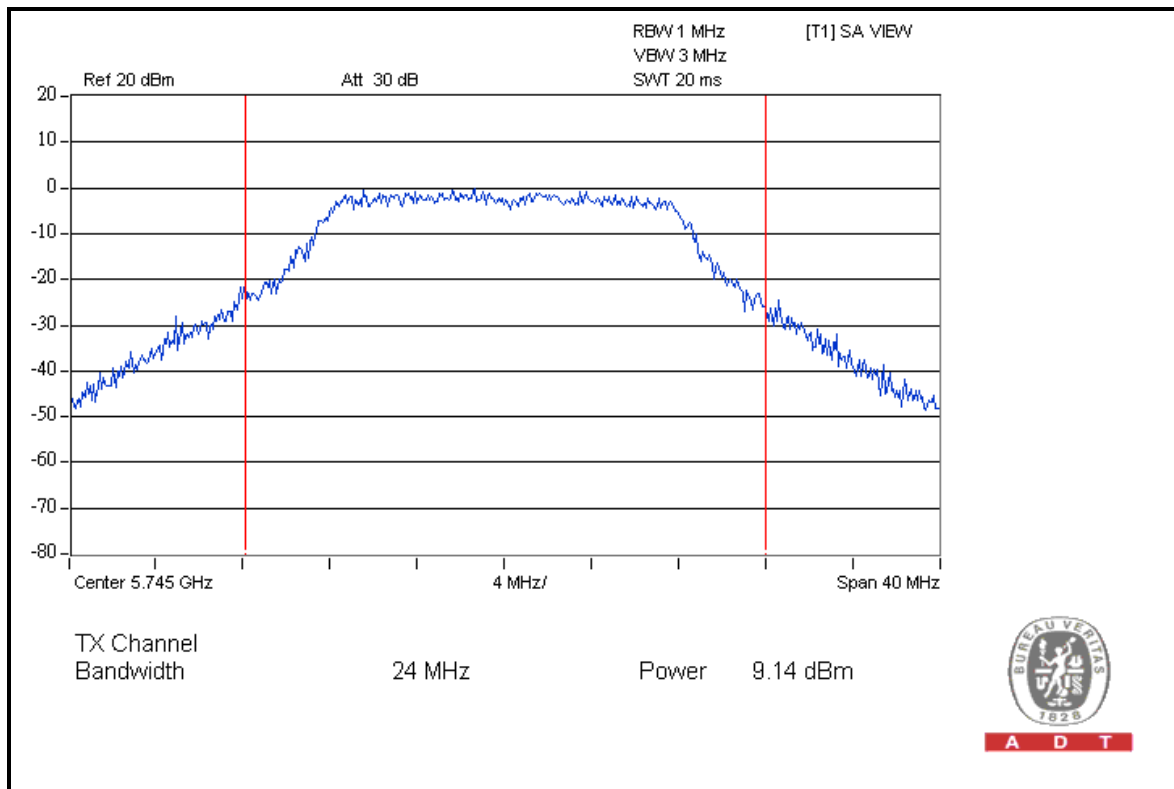



A D T

CH 157

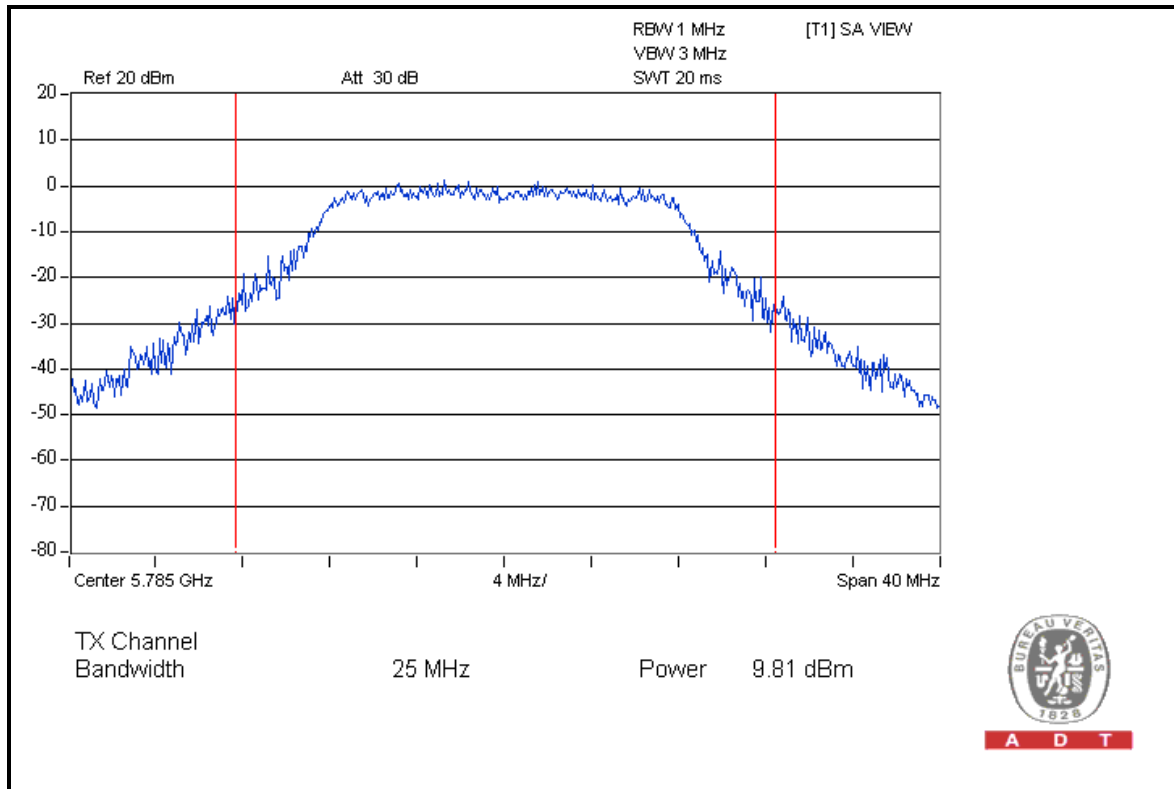

CH 165

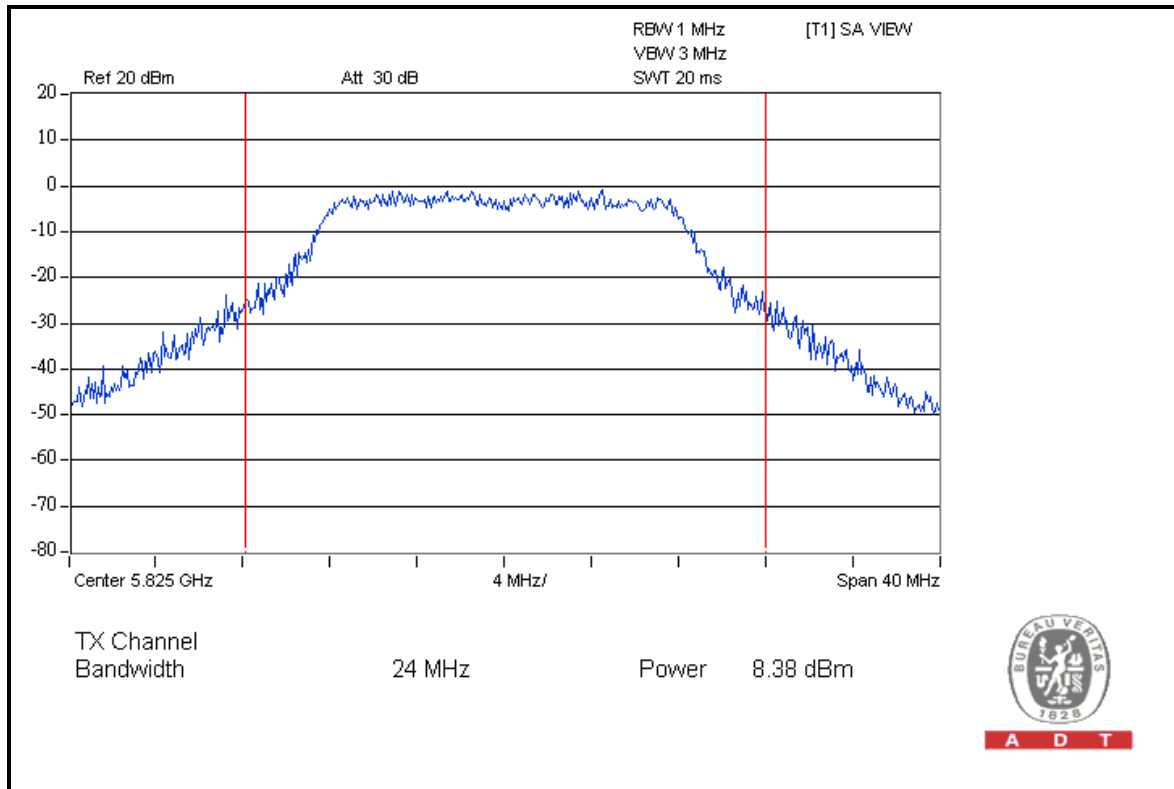



A D T

DRAFT 802.11n (40MHz) OFDM MODULATION

MODULATION TYPE	BPSK	TRANSFER RATE	13.5Mbps
INPUT POWER	120Vac, 60Hz	ENVIRONMENTAL CONDITIONS	25deg.C, 65% RH, 1010hPa
TESTED BY	Chad Lee	TEST MODE	A

CHAN.	CHAN. FREQ. (MHz)	PEAK POWER OUTPUT (dBm)		TOTAL PEAK POWER (mW)	TOTAL PEAK POWER (dBm)	PEAK POWER LIMIT (dBm)	PASS / FAIL
		CHAIN 0	CHAIN 1				
151	5755	11.38	11.43	27.640	14.42	22	PASS
159	5795	12.58	12.61	36.352	15.61	22	PASS



A D T

FOR CHAIN 0: CH 151

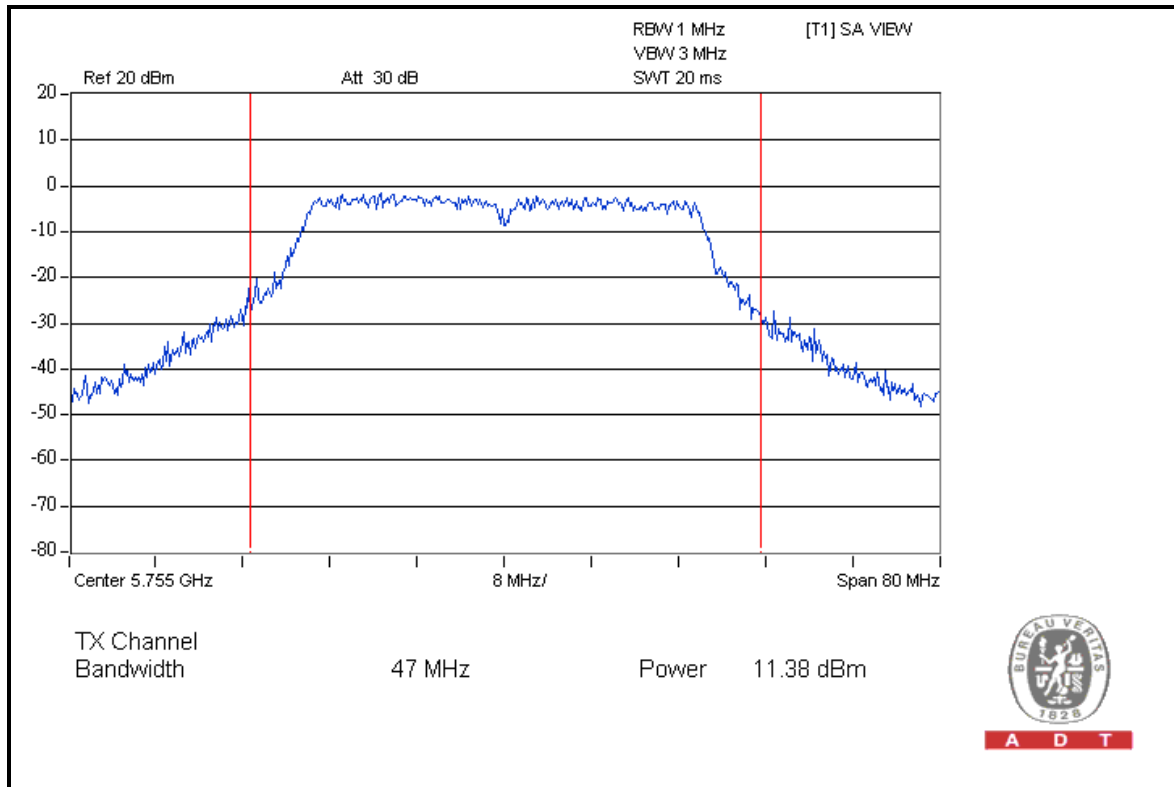

CH 159

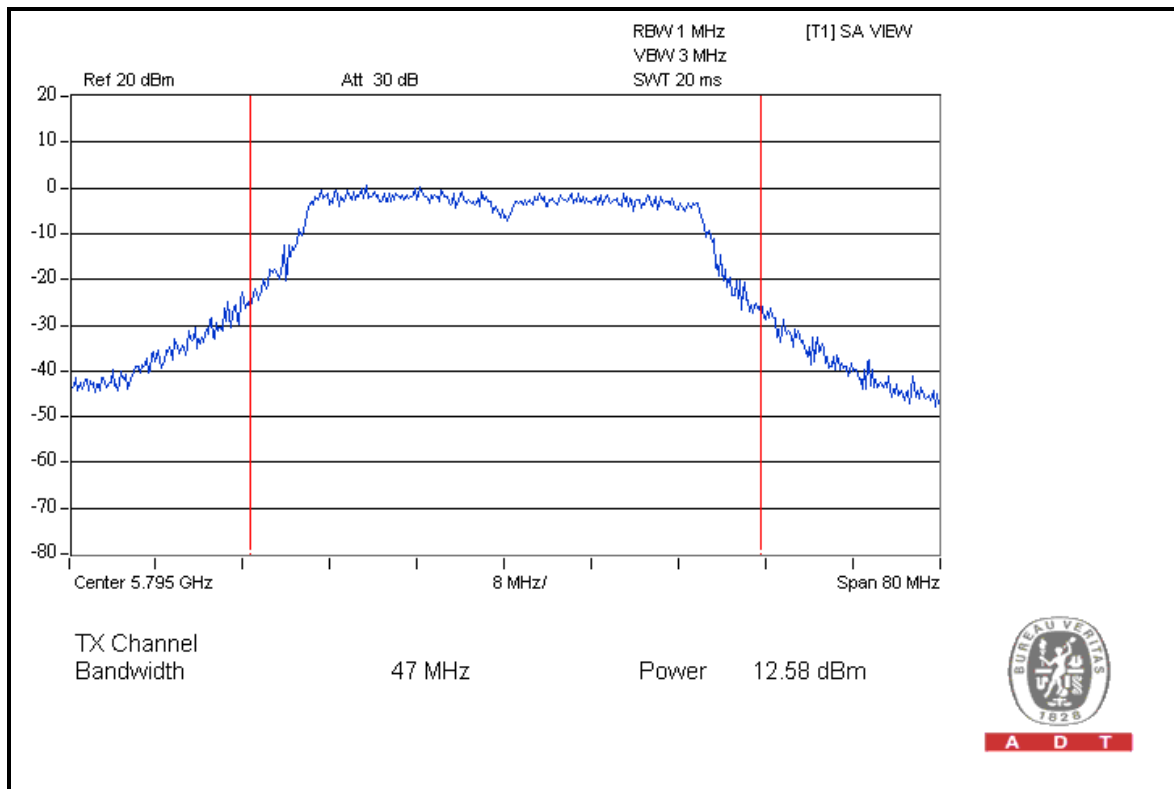



A D T

FOR CHAIN 1: CH 151

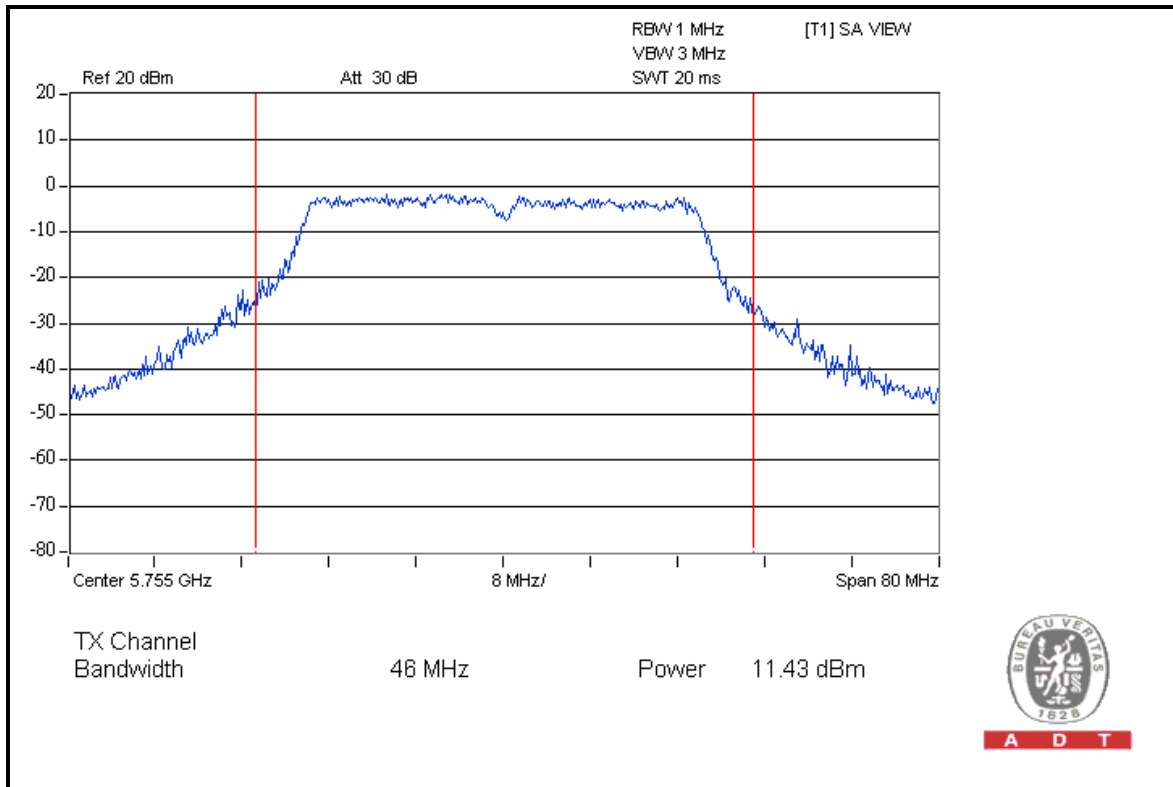

CH 159

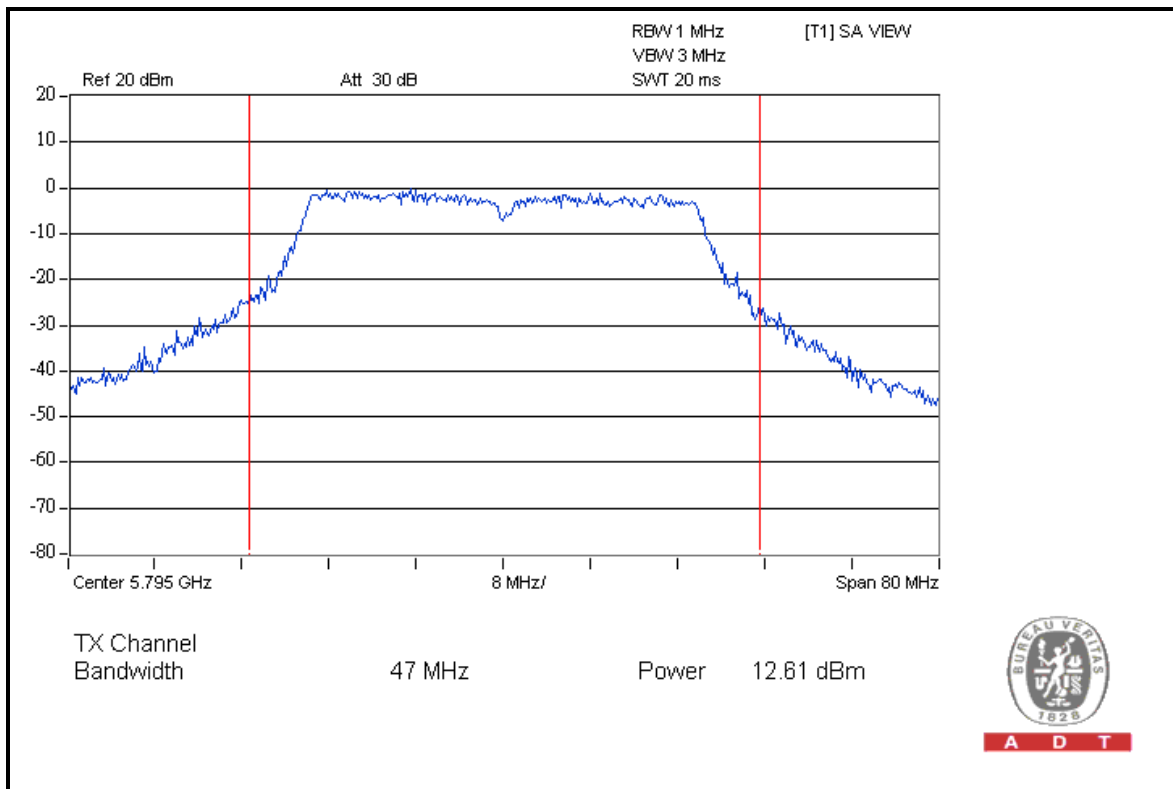



A D T

MODULATION TYPE	BPSK	TRANSFER RATE	13.5Mbps
INPUT POWER	120Vac, 60Hz	ENVIRONMENTAL CONDITIONS	25deg.C, 65% RH, 1010hPa
TESTED BY	Chad Lee	TEST MODE	C

CHAN.	CHAN. FREQ. (MHz)	PEAK POWER OUTPUT (dBm)		TOTAL PEAK POWER (mW)	TOTAL PEAK POWER (dBm)	PEAK POWER LIMIT (dBm)	PASS / FAIL
		CHAIN 0	CHAIN 1				
151	5755	9.47	8.97	16.740	12.24	13	PASS
159	5795	8.23	7.73	12.582	11.00	13	PASS



A D T

FOR CHAIN 0: CH 151

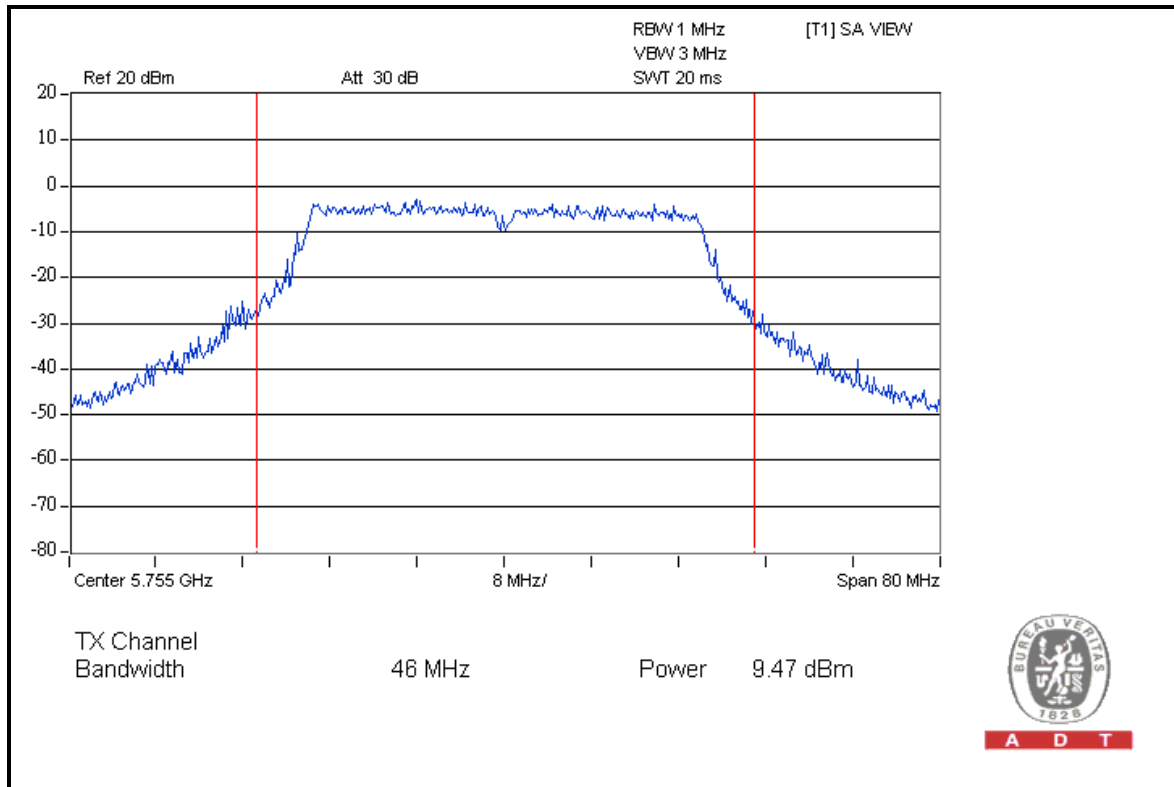

CH 159

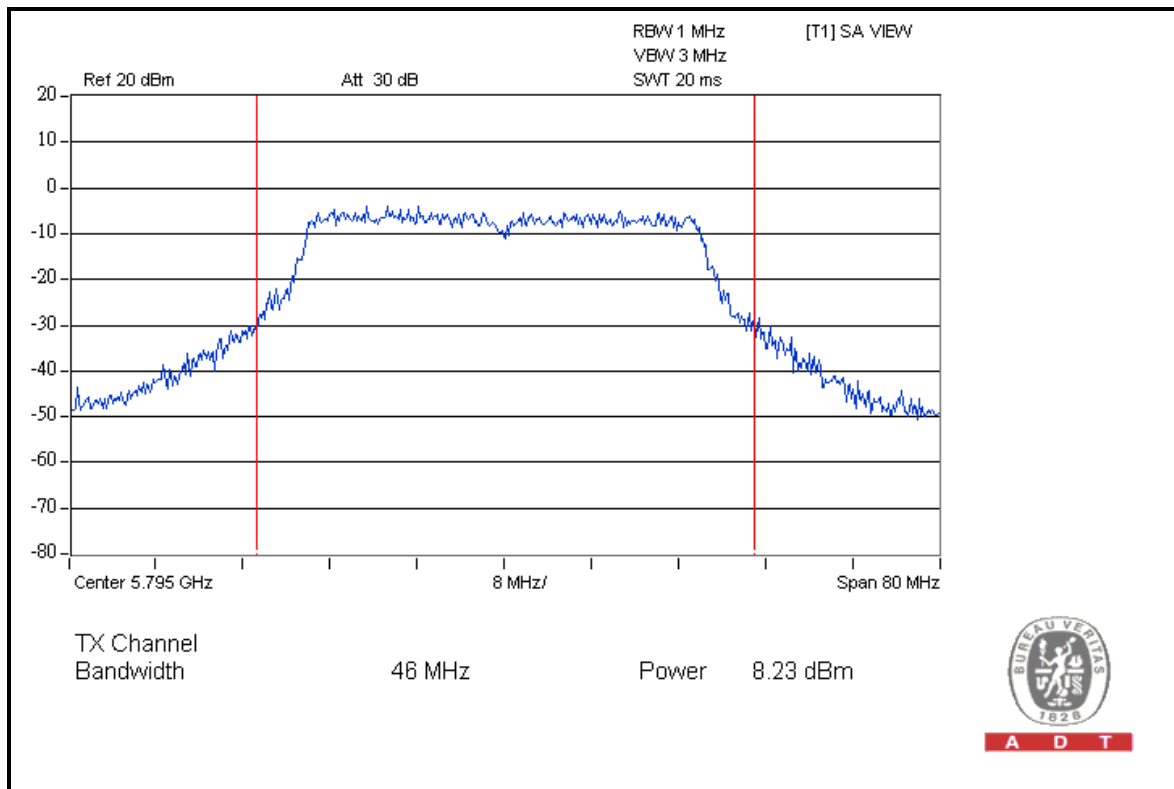



A D T

FOR CHAIN 1: CH 151

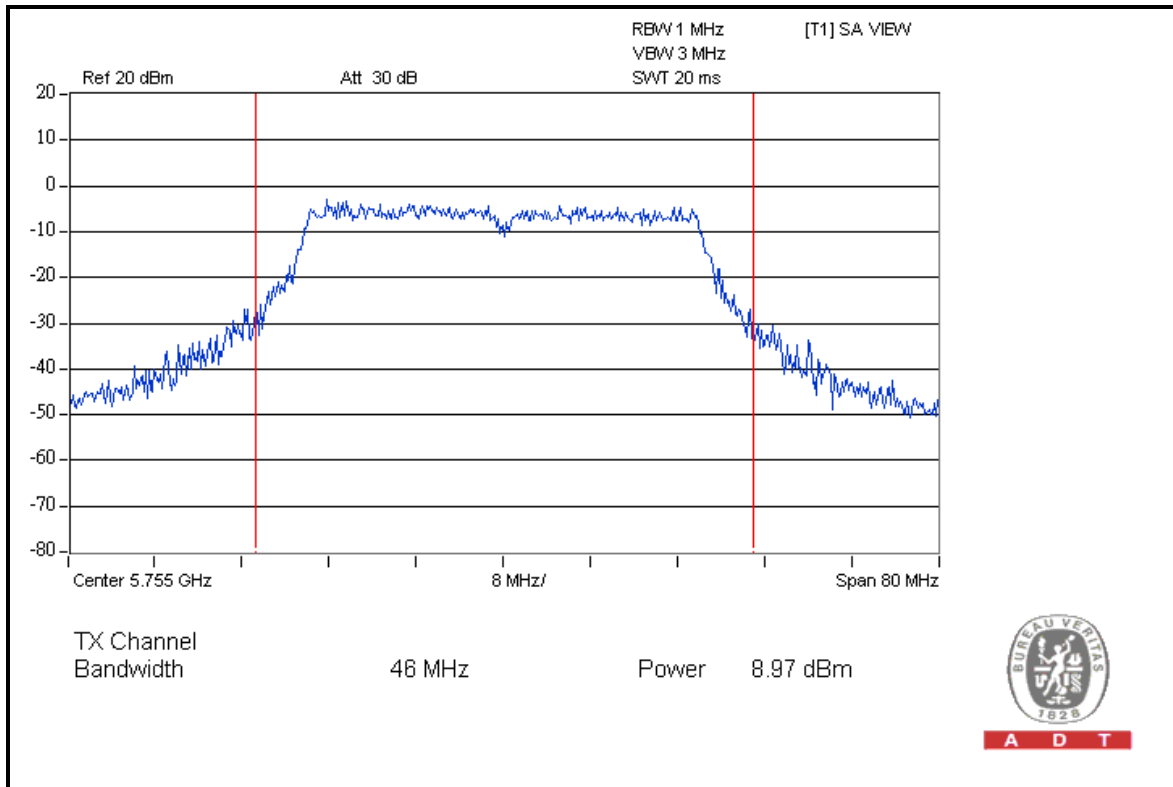

CH 159

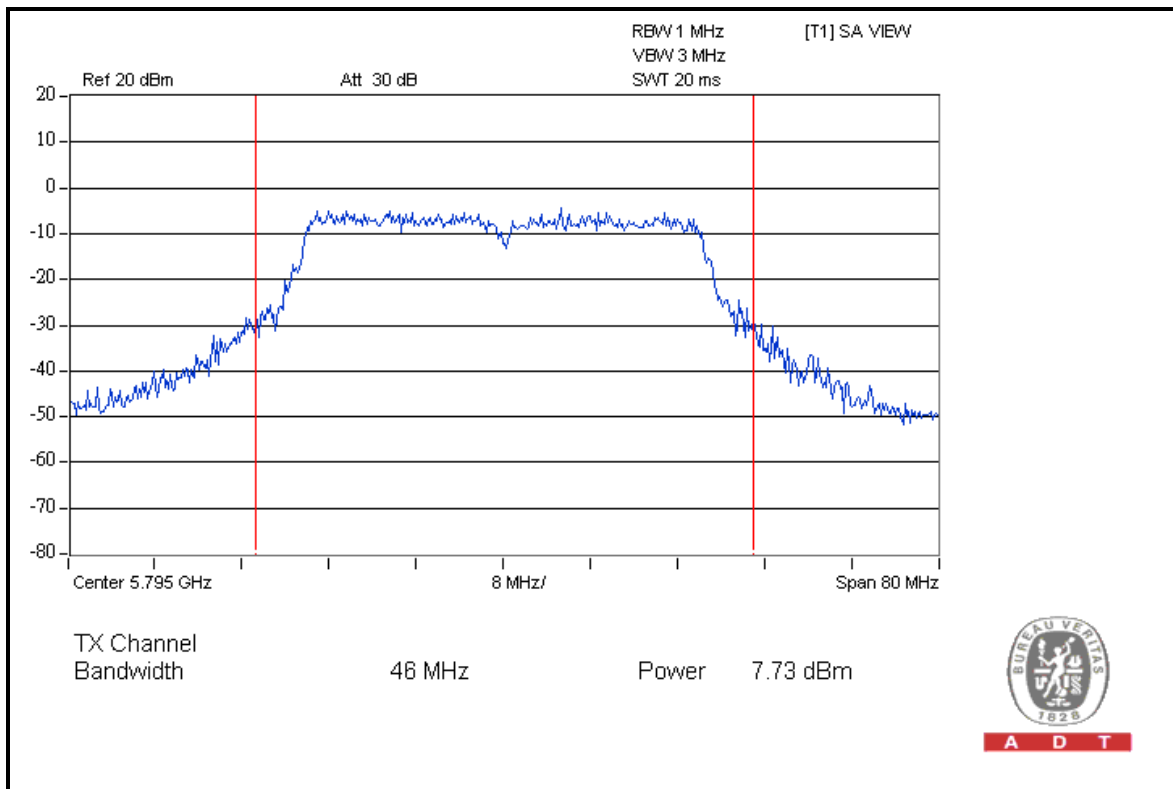



A D T

26dB OCCUPIED BANDWIDTH: 802.11a OFDM MODULATION

MODULATION TYPE	BPSK	TRANSFER RATE	6.0Mbps
INPUT POWER	120Vac, 60Hz	ENVIRONMENTAL CONDITIONS	25deg.C, 65% RH, 1010hPa
TESTED BY	Chad Lee	TEST MODE	A

CHANNEL	CHANNEL FREQUENCY (MHz)	26dBc OCCUPIED BANDWIDTH (MHz)		PASS / FAIL
		CHAIN 0	CHAIN 1	
149	5745	24.03	23.83	PASS
157	5785	23.11	24.07	PASS
165	5825	24.05	23.80	PASS



A D T

FOR CHAIN 0: CH 149

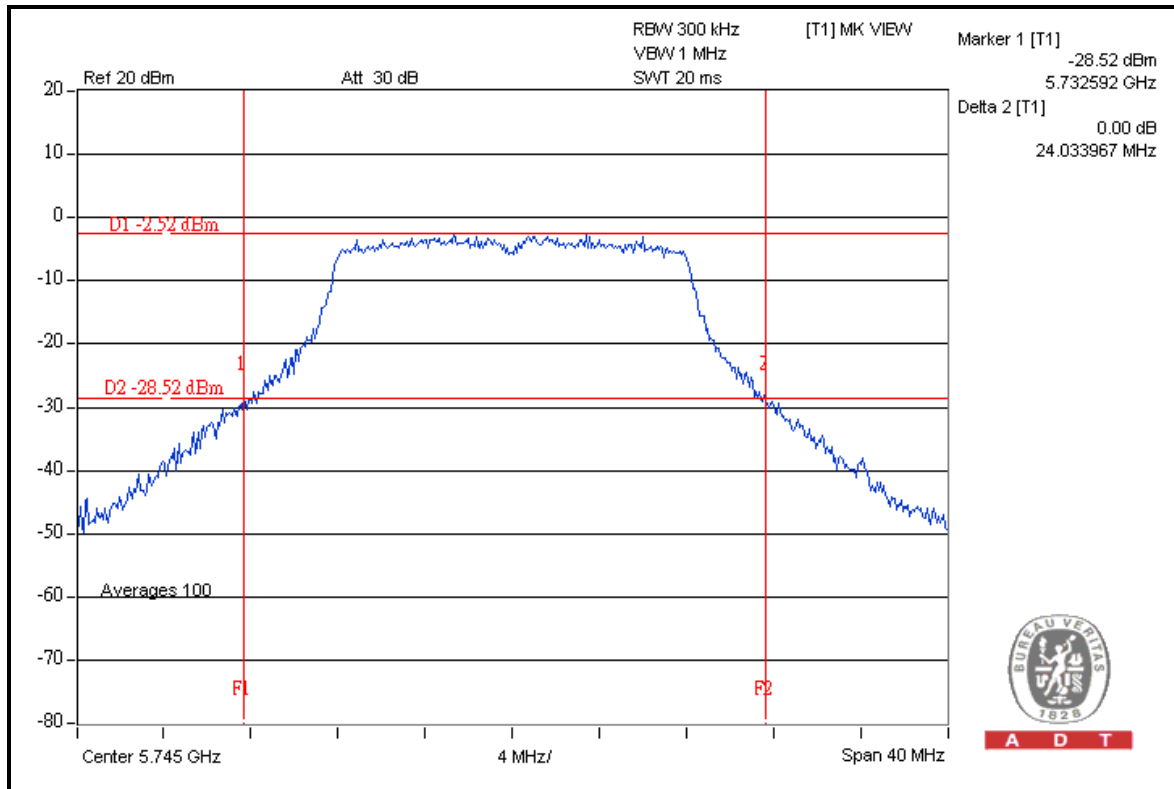

CH 157

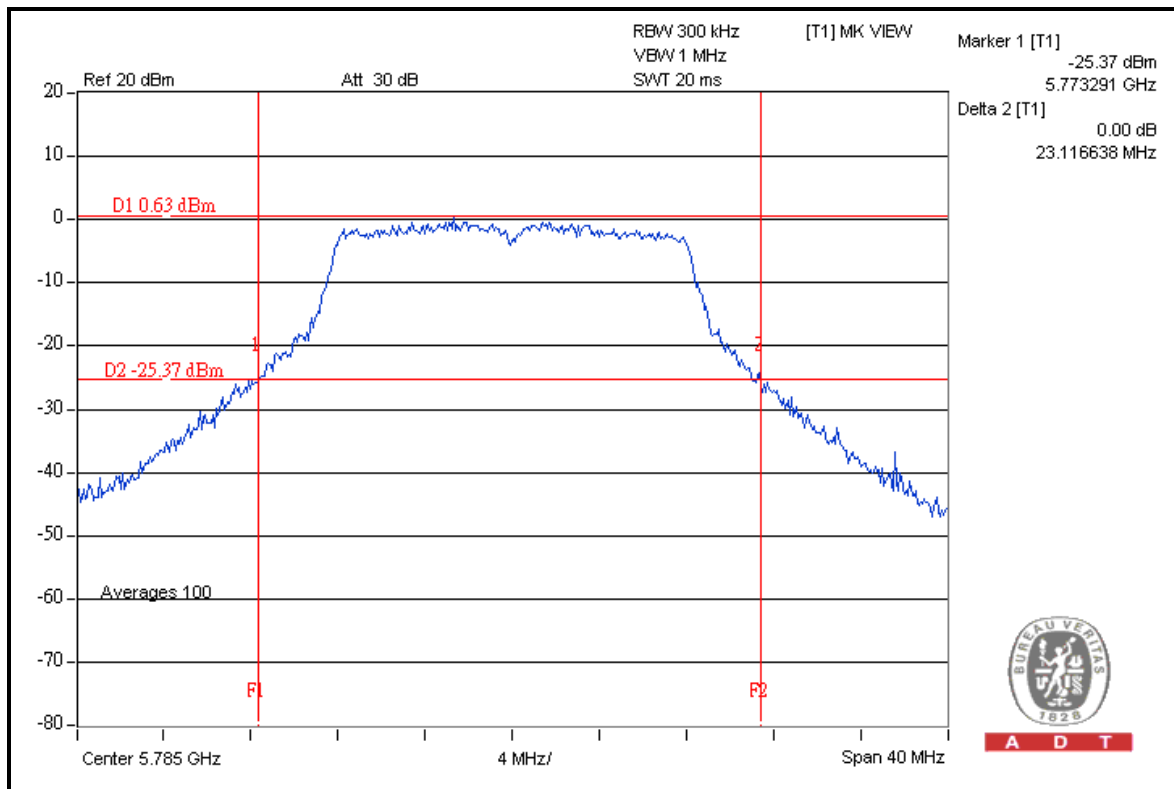



A D T

CH 165

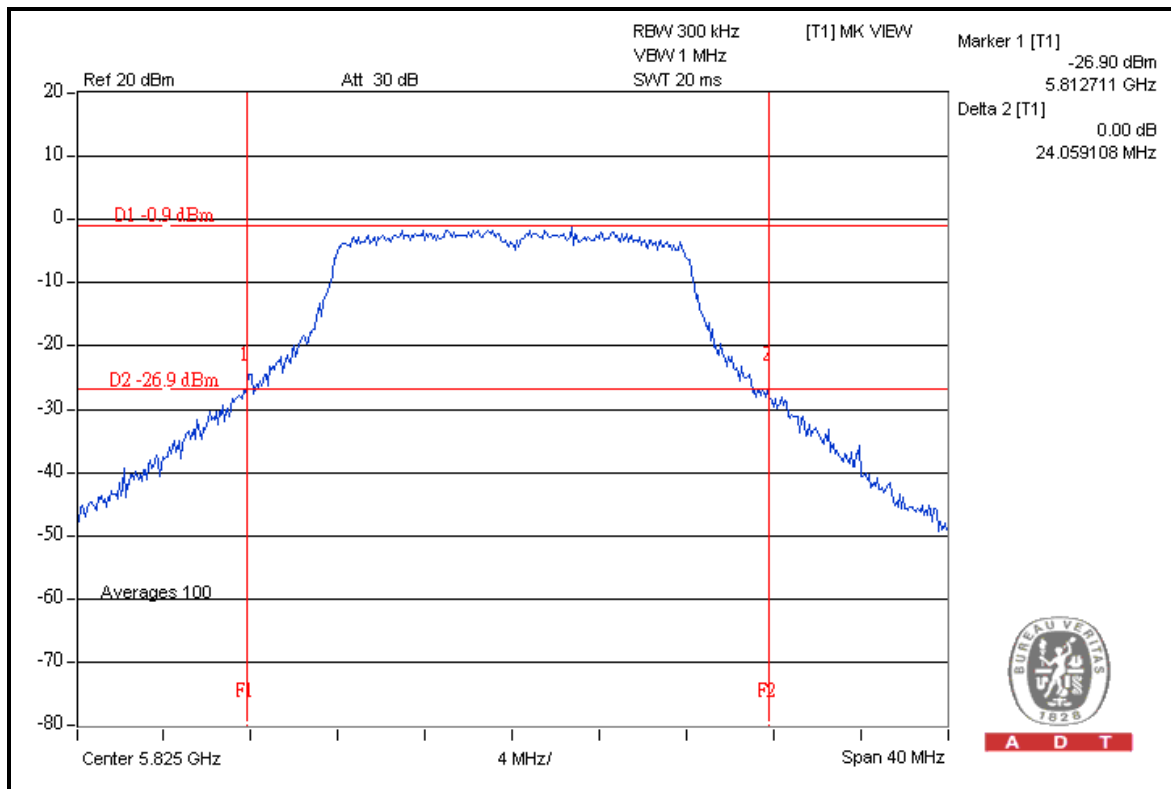

FOR CHAIN 1: CH 149

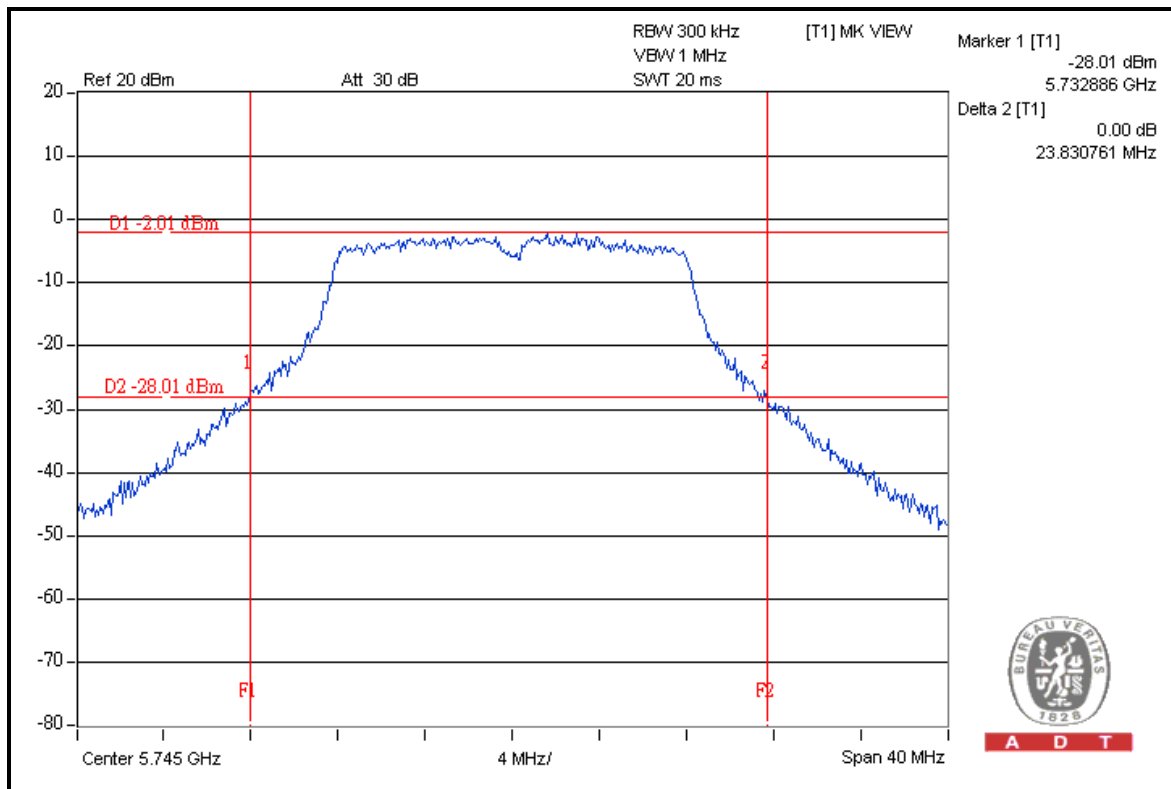



A D T

CH 157

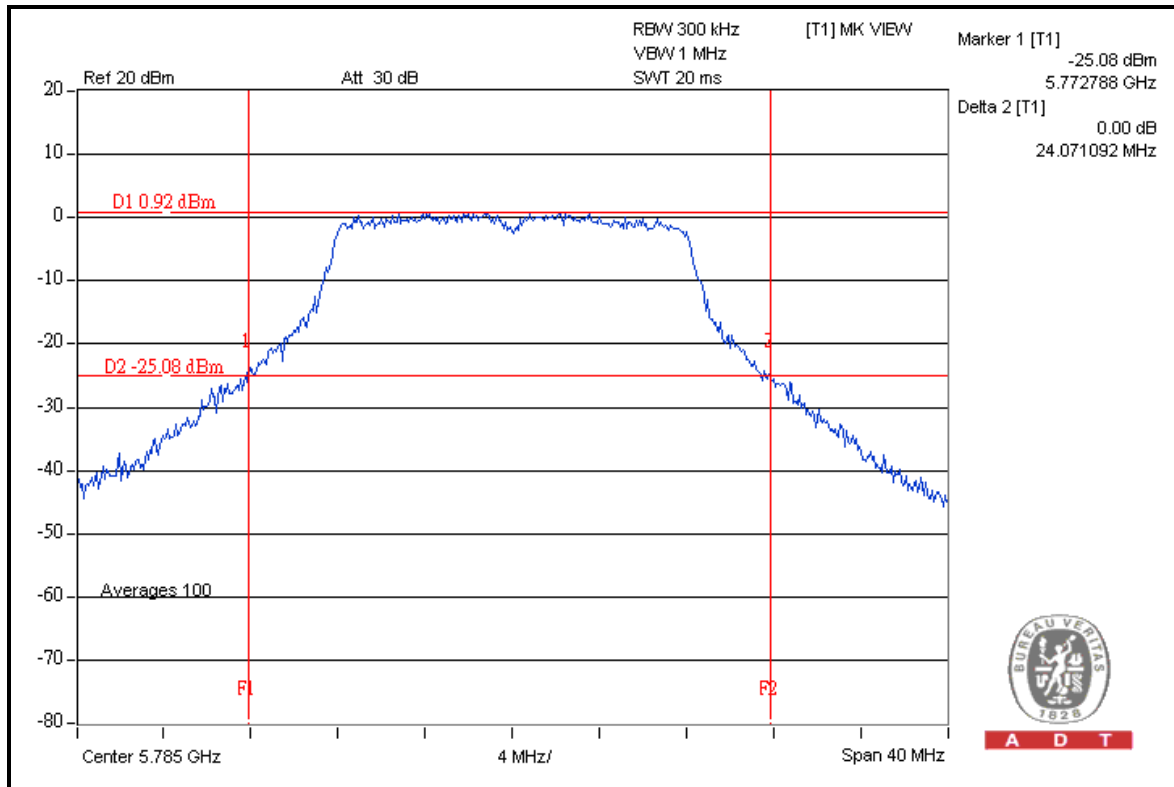

CH 165

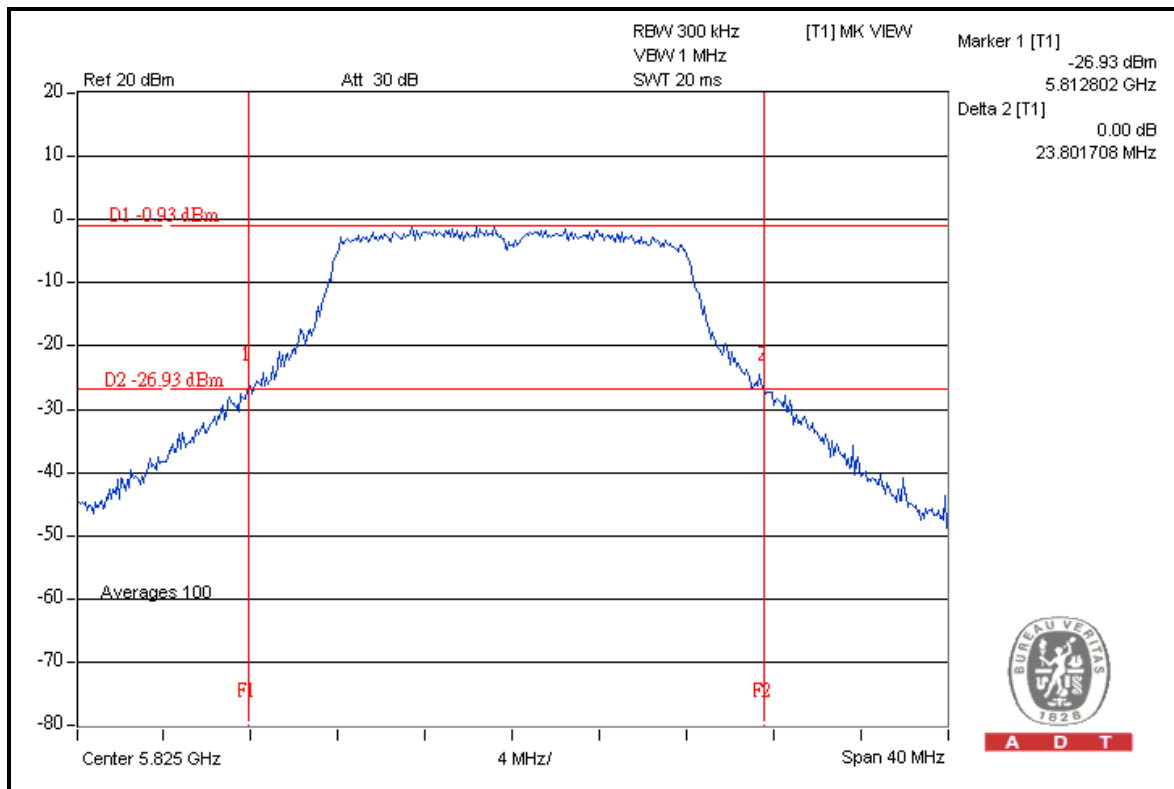



A D T

MODULATION TYPE	BPSK	TRANSFER RATE	6.0Mbps
INPUT POWER	120Vac, 60Hz	ENVIRONMENTAL CONDITIONS	25deg.C, 65% RH, 1010hPa
TESTED BY	Chad Lee	TEST MODE	C

CHANNEL	CHANNEL FREQUENCY (MHz)	26dBc OCCUPIED BANDWIDTH (MHz)		PASS / FAIL
		CHAIN 0	CHAIN 1	
149	5745	24.09	24.52	PASS
157	5785	23.68	24.89	PASS
165	5825	24.23	23.75	PASS



A D T

FOR CHAIN 0: CH 149

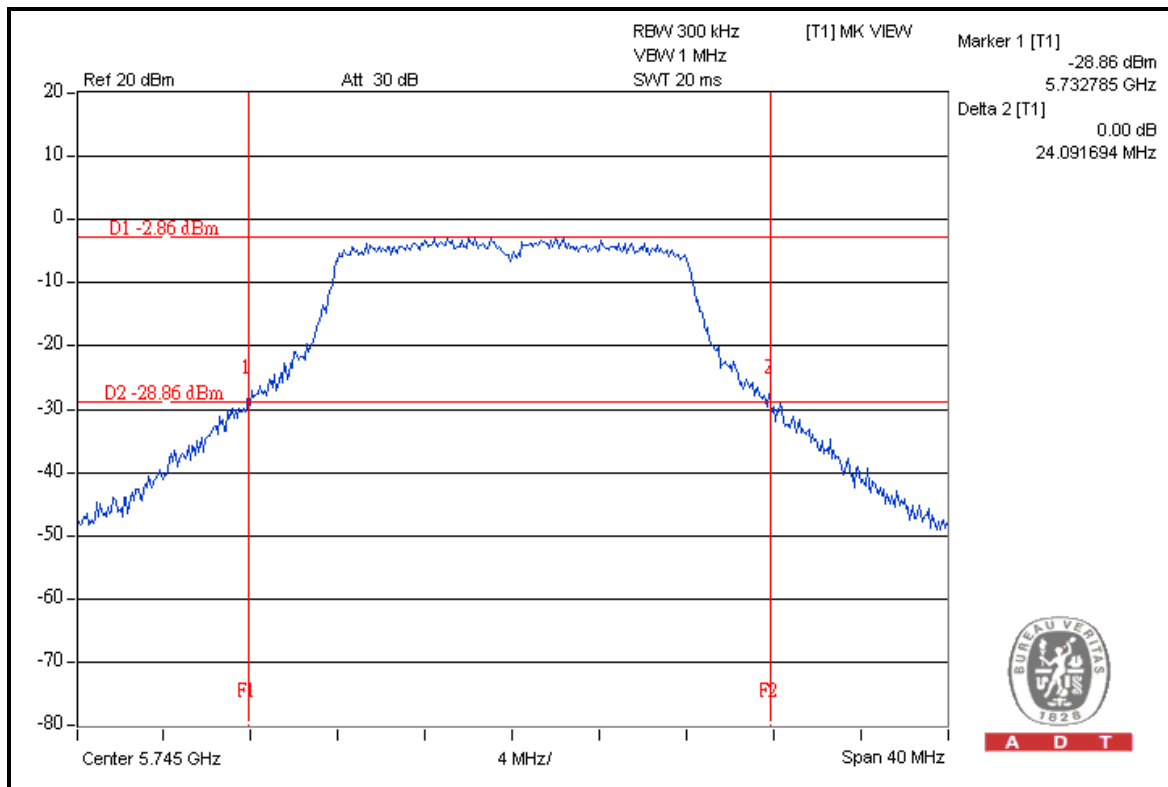

CH 157

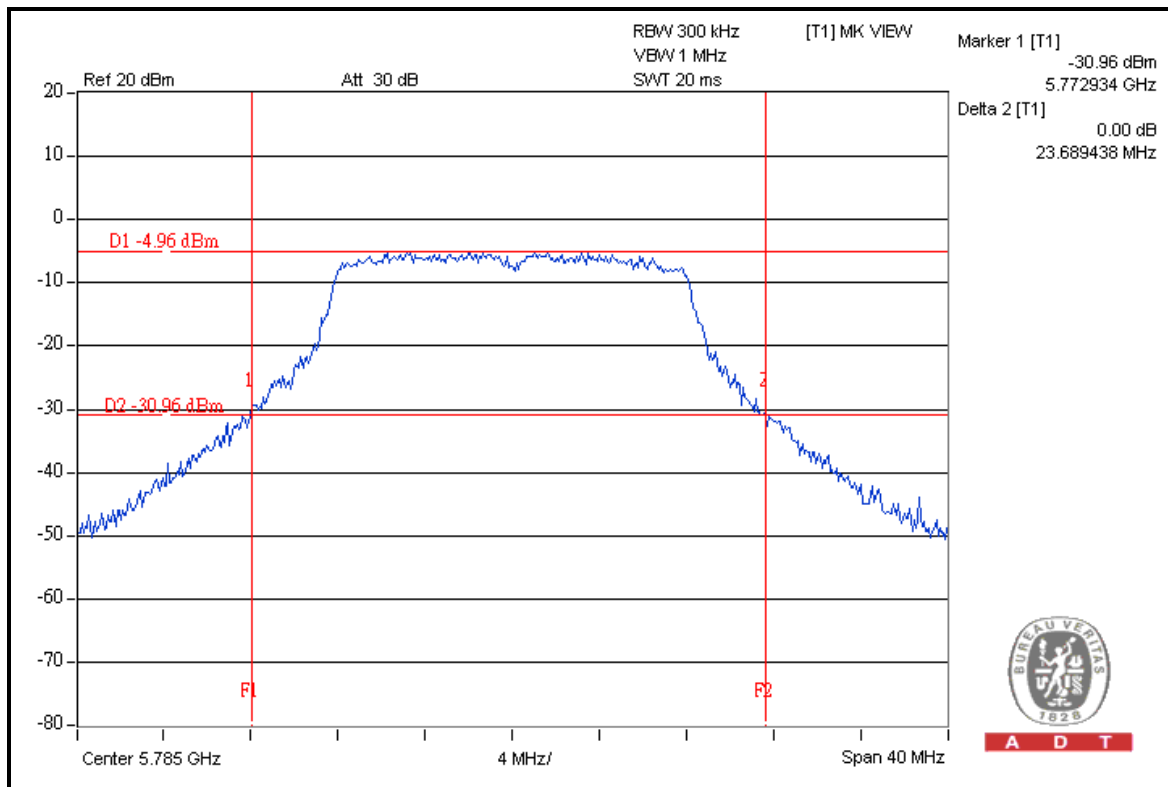



A D T

CH 165

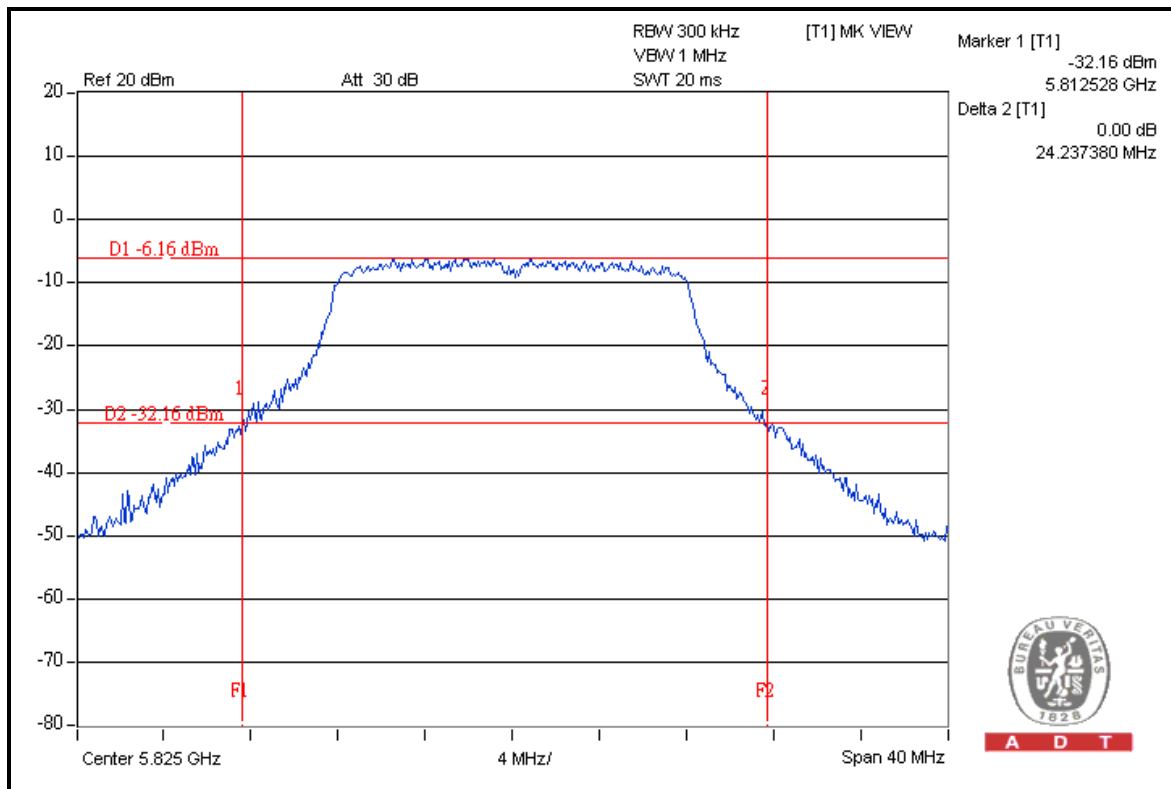

FOR CHAIN 1: CH 149

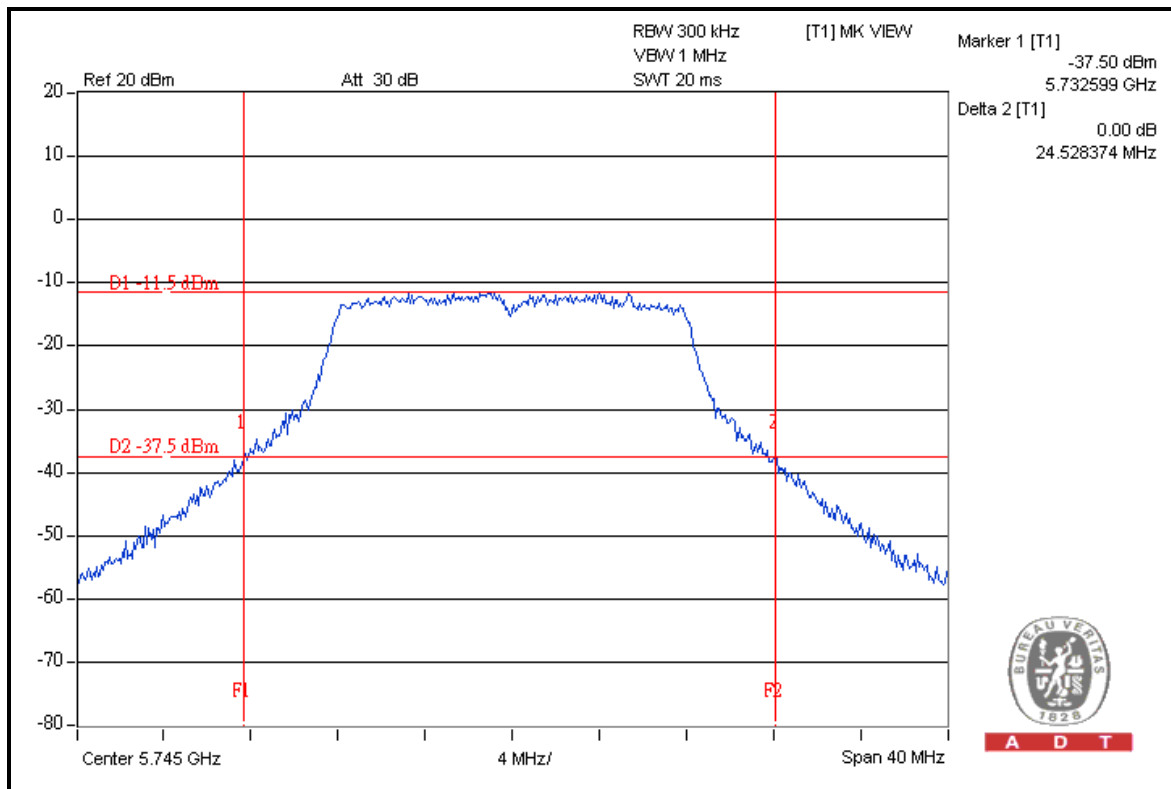



A D T

CH 157

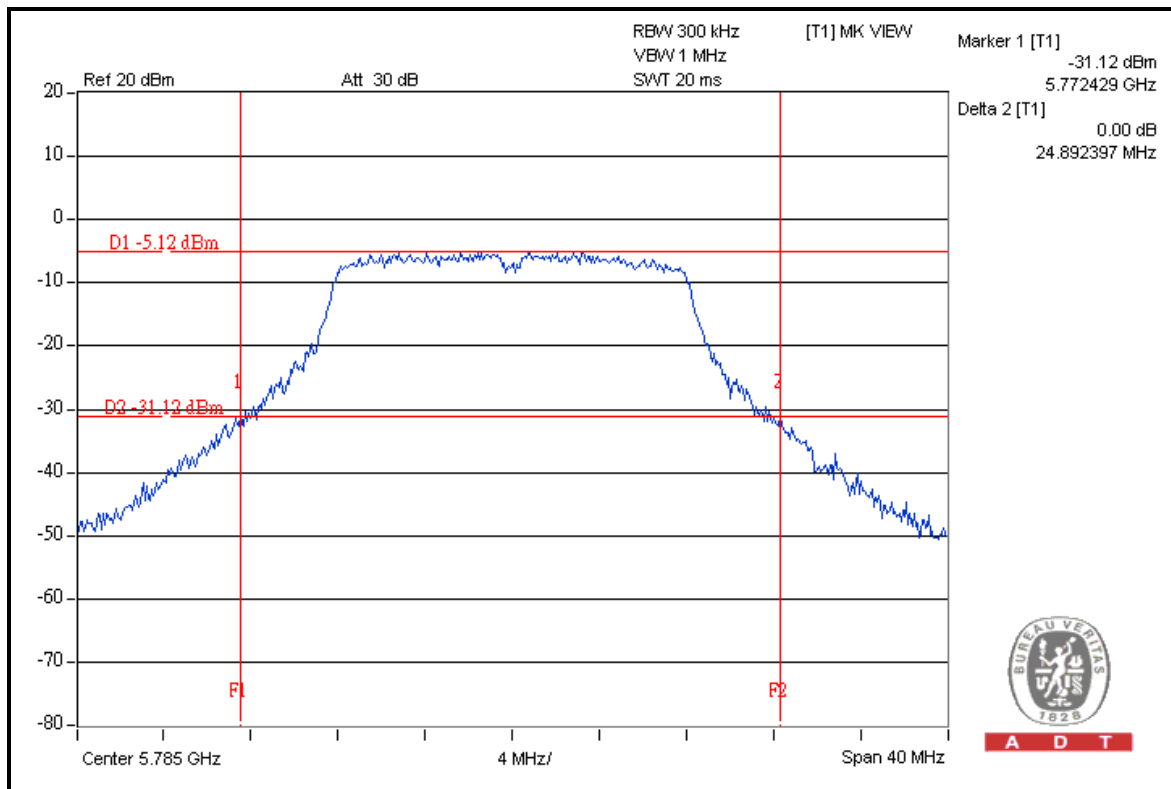

CH 165

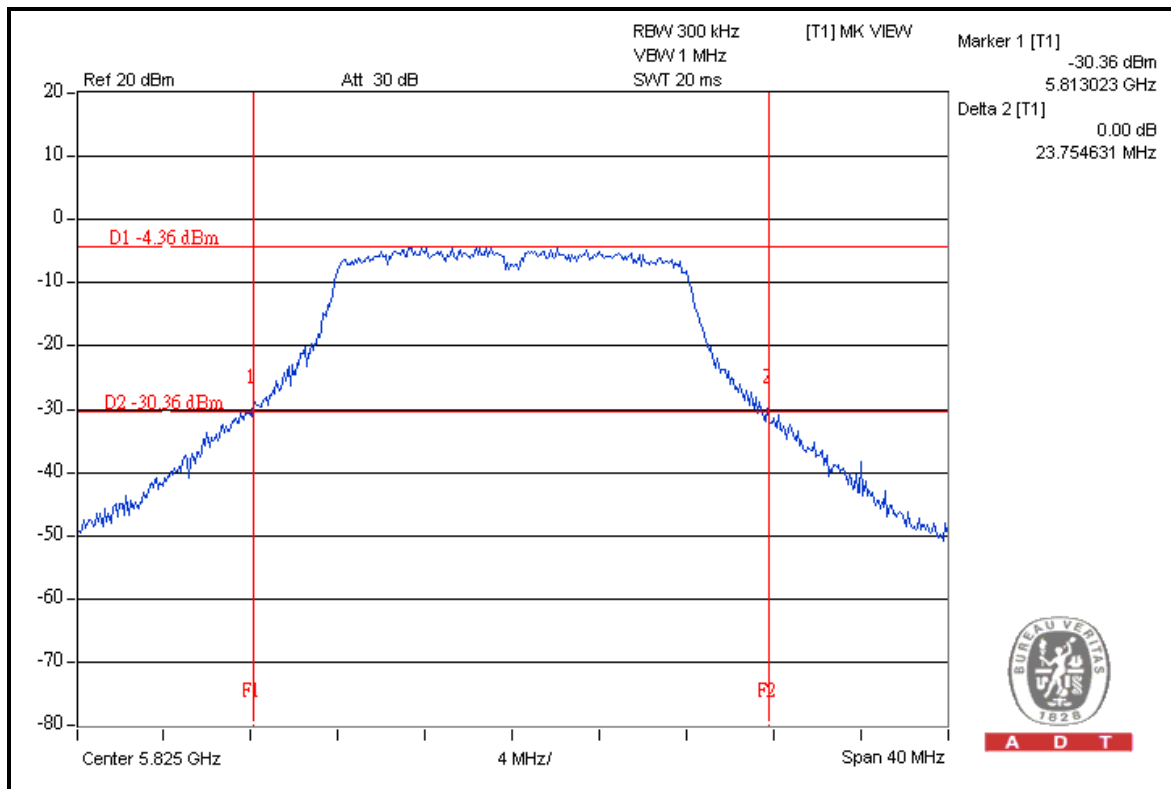



A D T

DRAFT 802.11n (20MHz) OFDM MODULATION

MODULATION TYPE	BPSK	TRANSFER RATE	6.5Mbps
INPUT POWER	120Vac, 60Hz	ENVIRONMENTAL CONDITIONS	25deg.C, 65% RH, 1010hPa
TESTED BY	Chad Lee	TEST MODE	A

CHANNEL	CHANNEL FREQUENCY (MHz)	26dBc OCCUPIED BANDWIDTH (MHz)		PASS / FAIL
		CHAIN 0	CHAIN 1	
149	5745	24.18	23.70	PASS
157	5785	24.05	23.49	PASS
165	5825	24.29	23.29	PASS



A D T

FOR CHAIN 0: CH 149

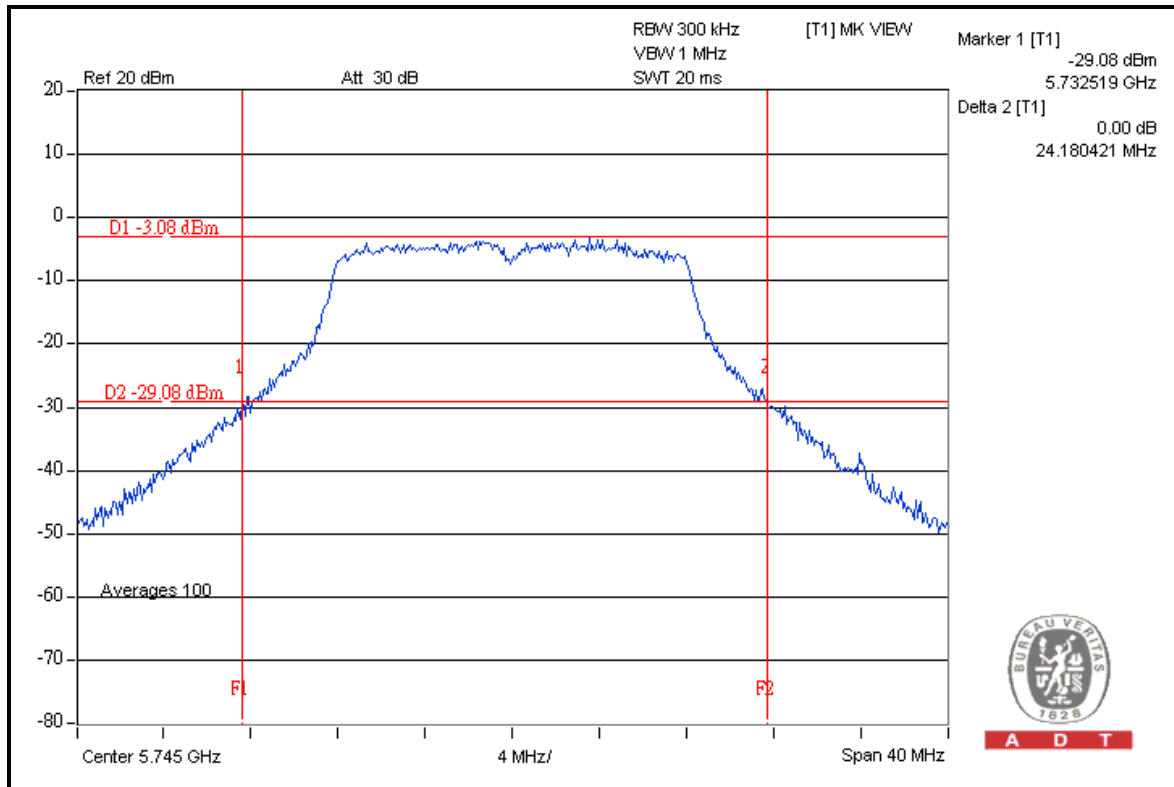

CH 157

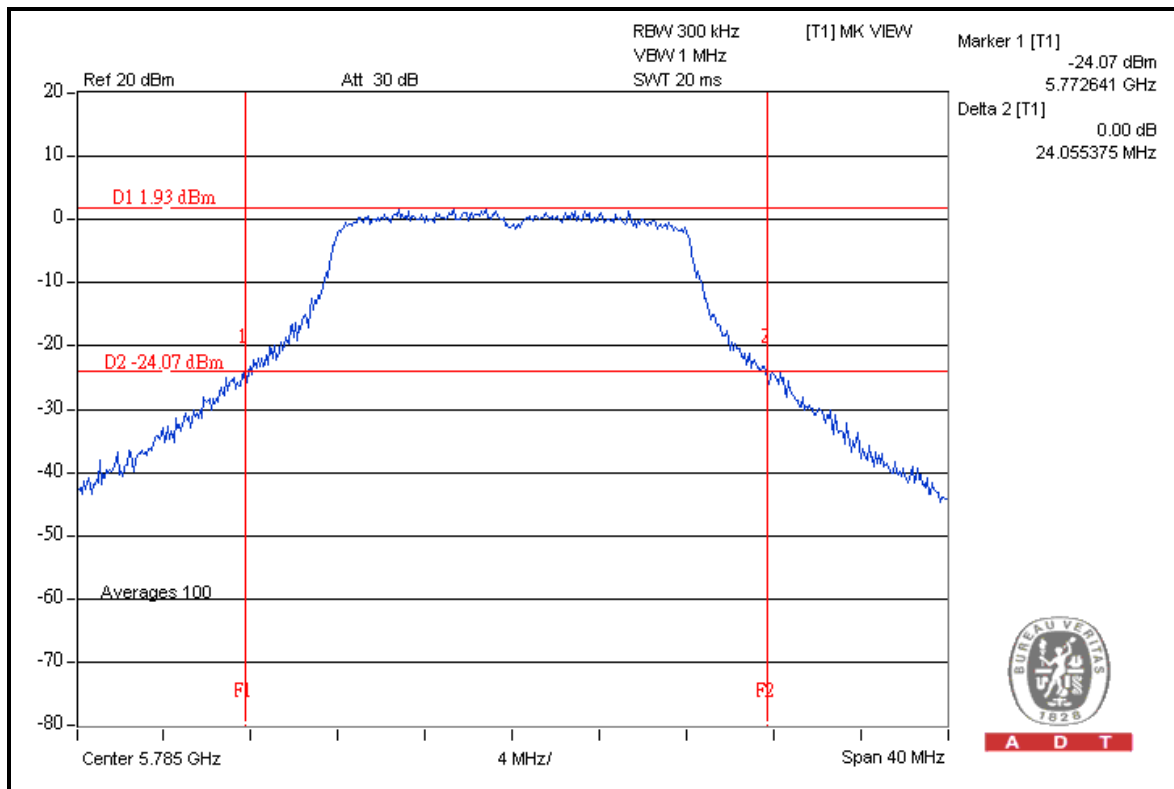



A D T

CH 165

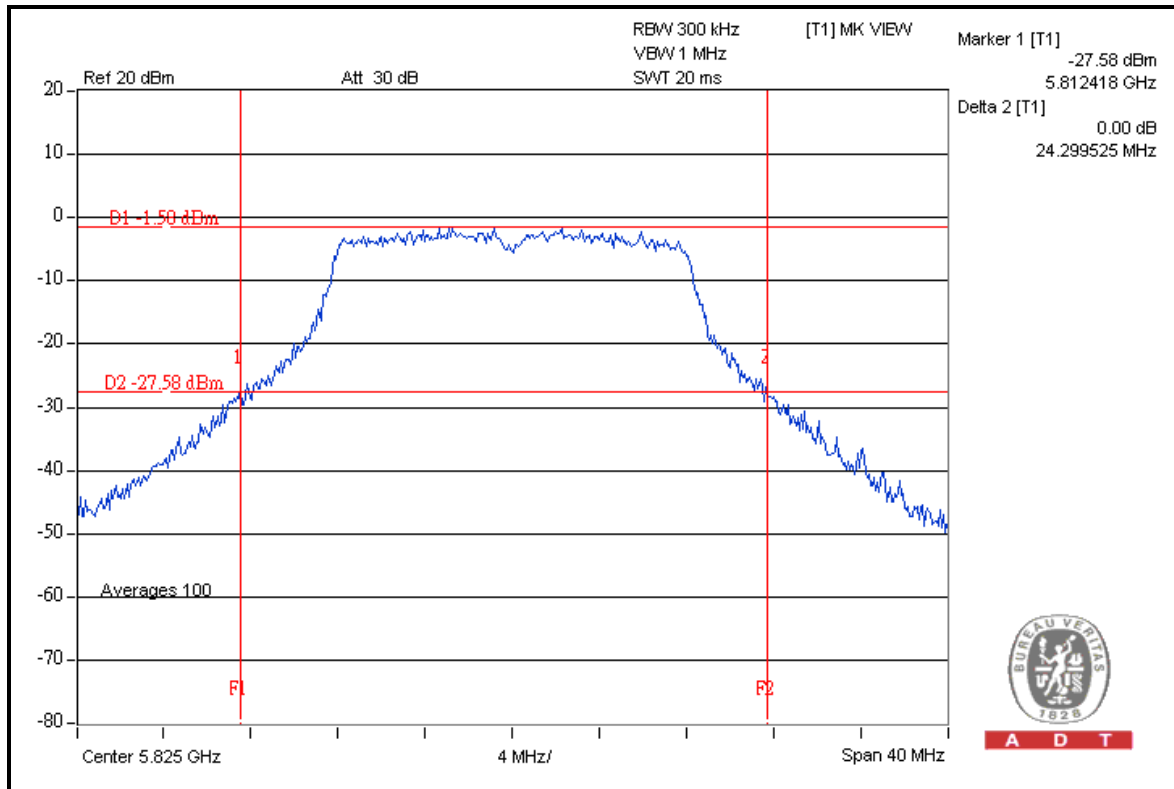

FOR CHAIN 1: CH 149

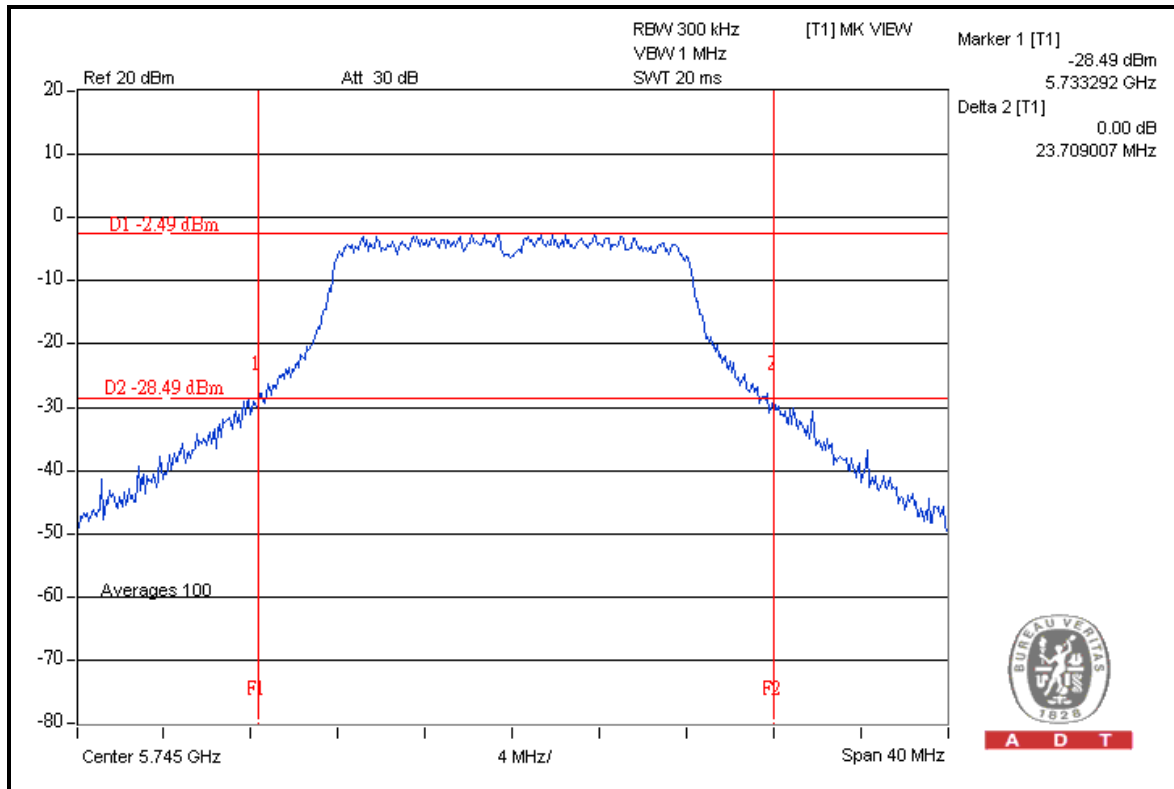



A D T

CH 157

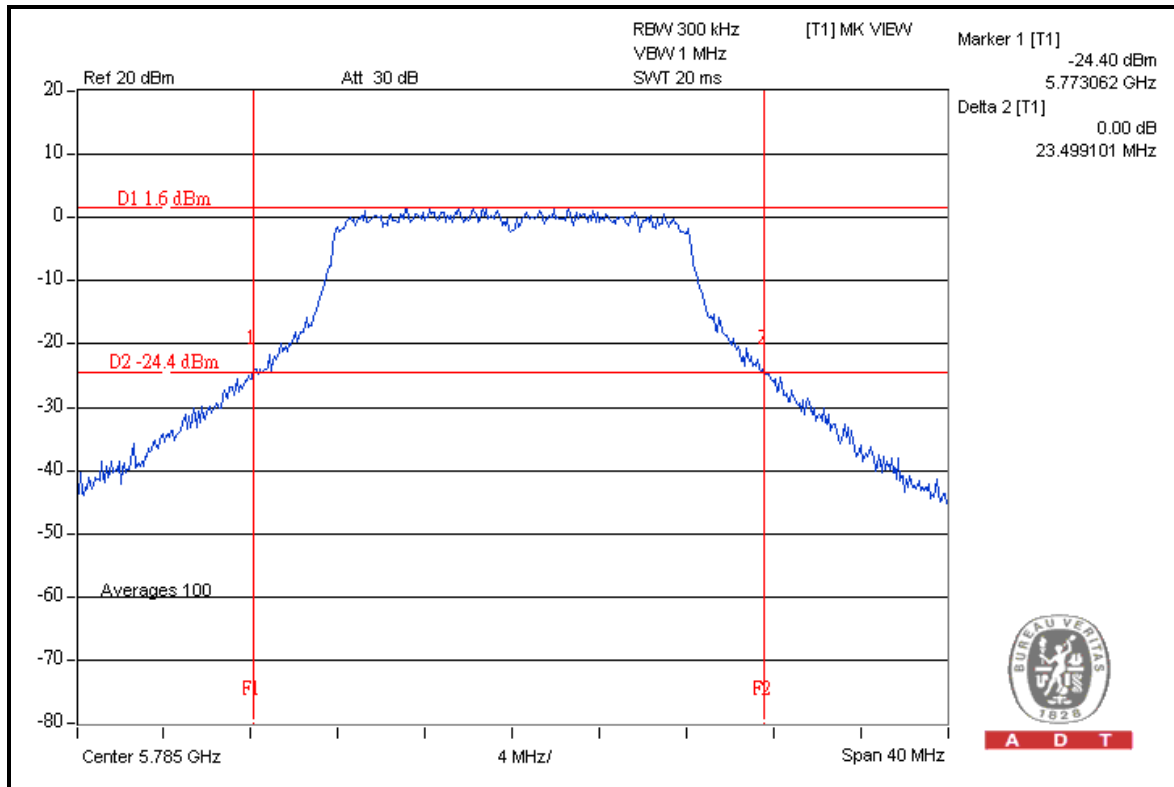

CH 165

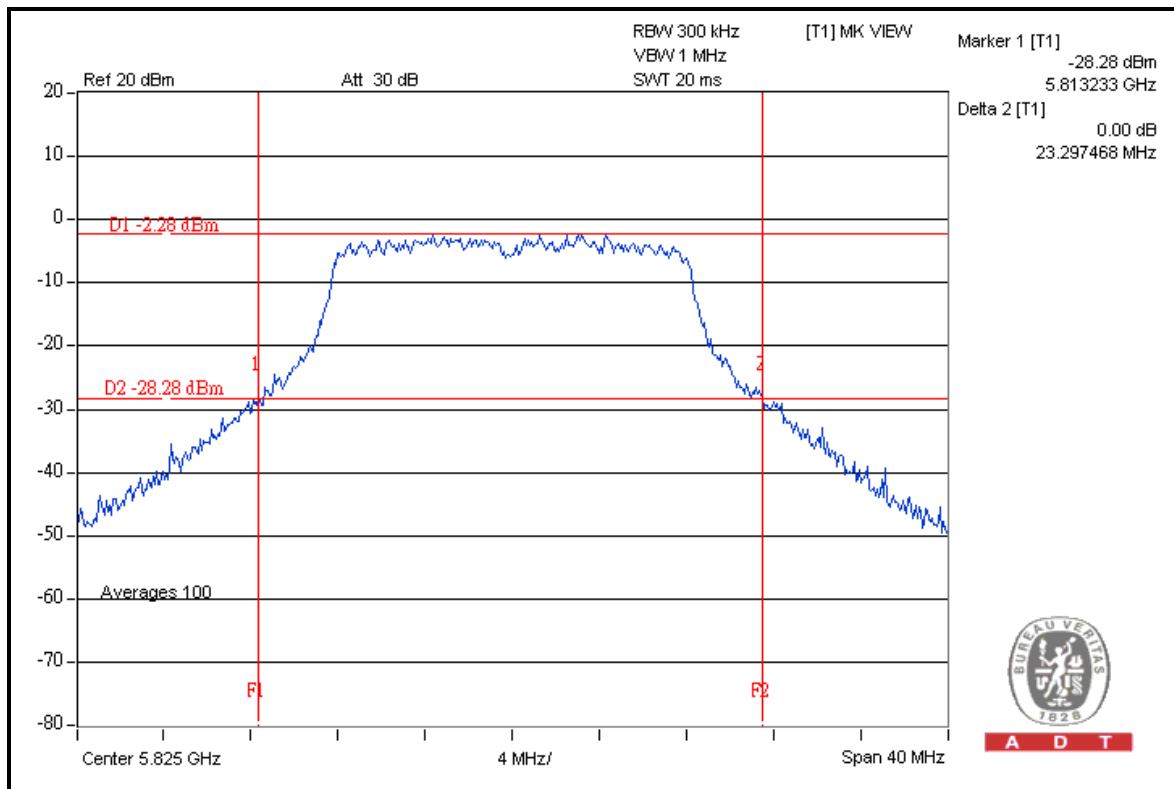



A D T

MODULATION TYPE	BPSK	TRANSFER RATE	6.5Mbps
INPUT POWER	120Vac, 60Hz	ENVIRONMENTAL CONDITIONS	25deg.C, 65% RH, 1010hPa
TESTED BY	Chad Lee	TEST MODE	C

CHANNEL	CHANNEL FREQUENCY (MHz)	26dBc OCCUPIED BANDWIDTH (MHz)		PASS / FAIL
		CHAIN 0	CHAIN 1	
149	5745	23.40	23.54	PASS
157	5785	23.54	24.27	PASS
165	5825	23.57	23.22	PASS



A D T

FOR CHAIN 0: CH 149

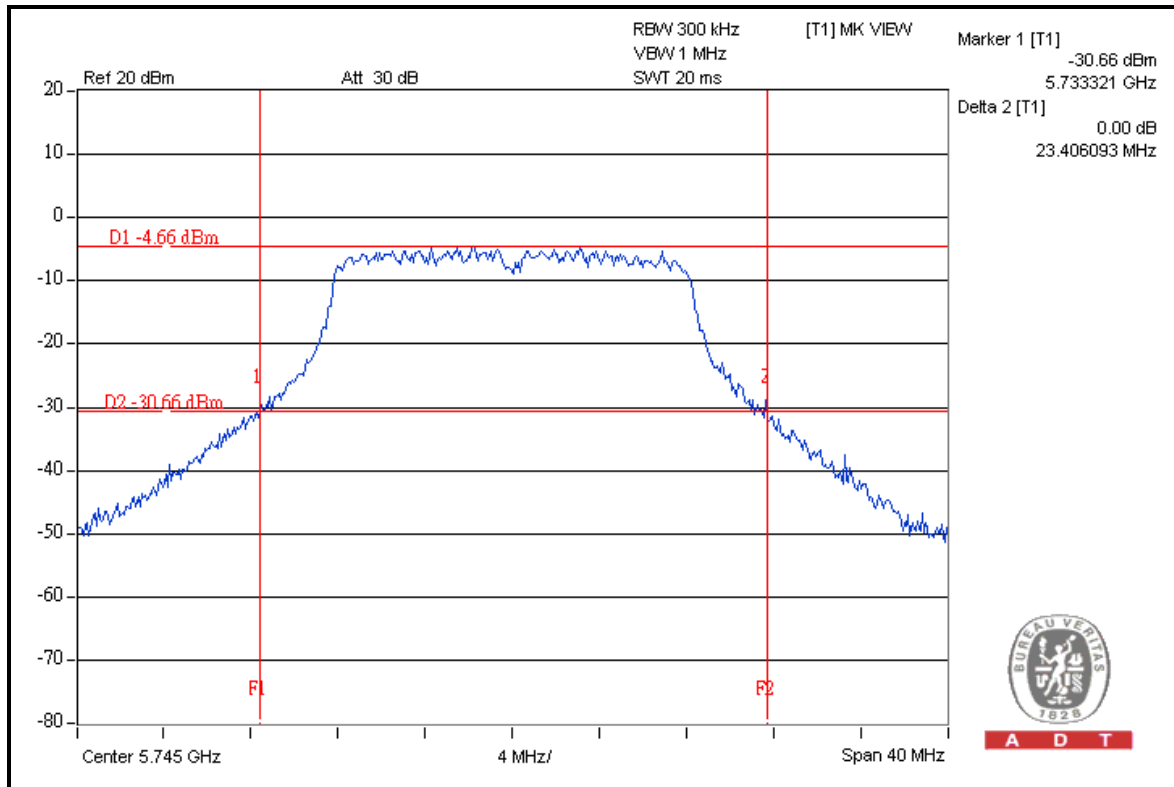

CH 157

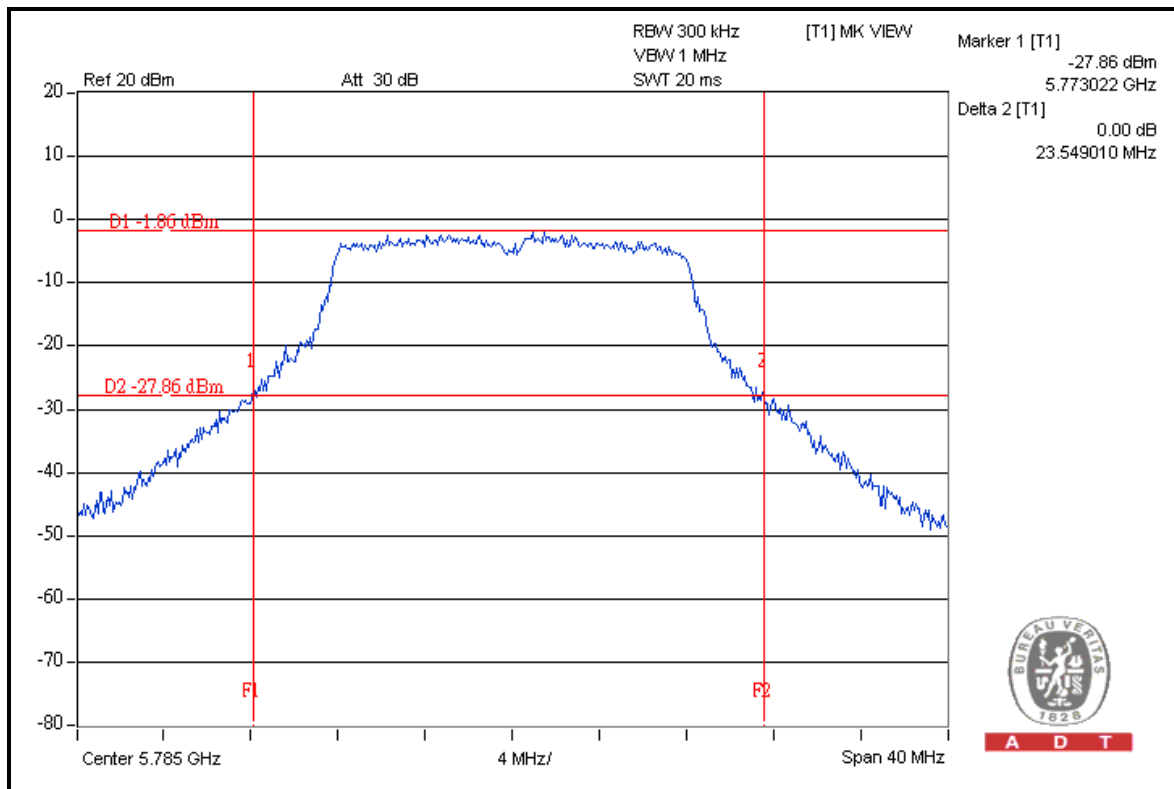



A D T

CH 165

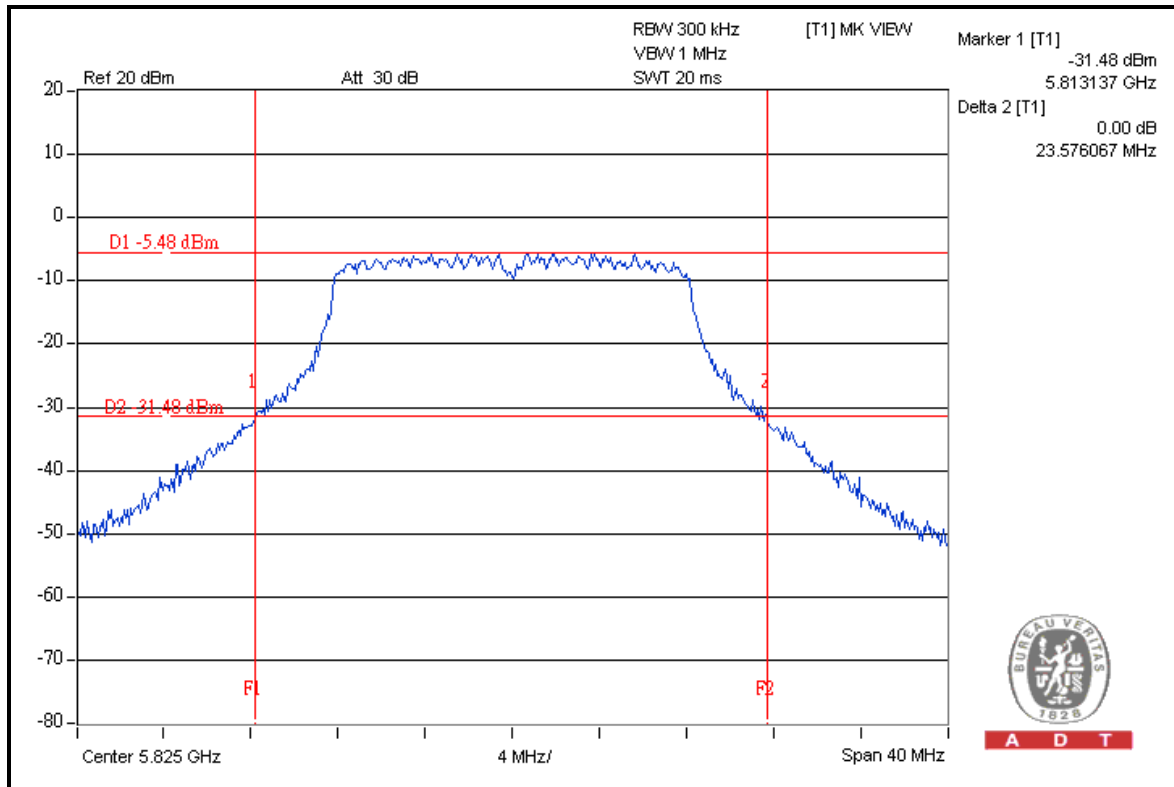

FOR CHAIN 1: CH 149

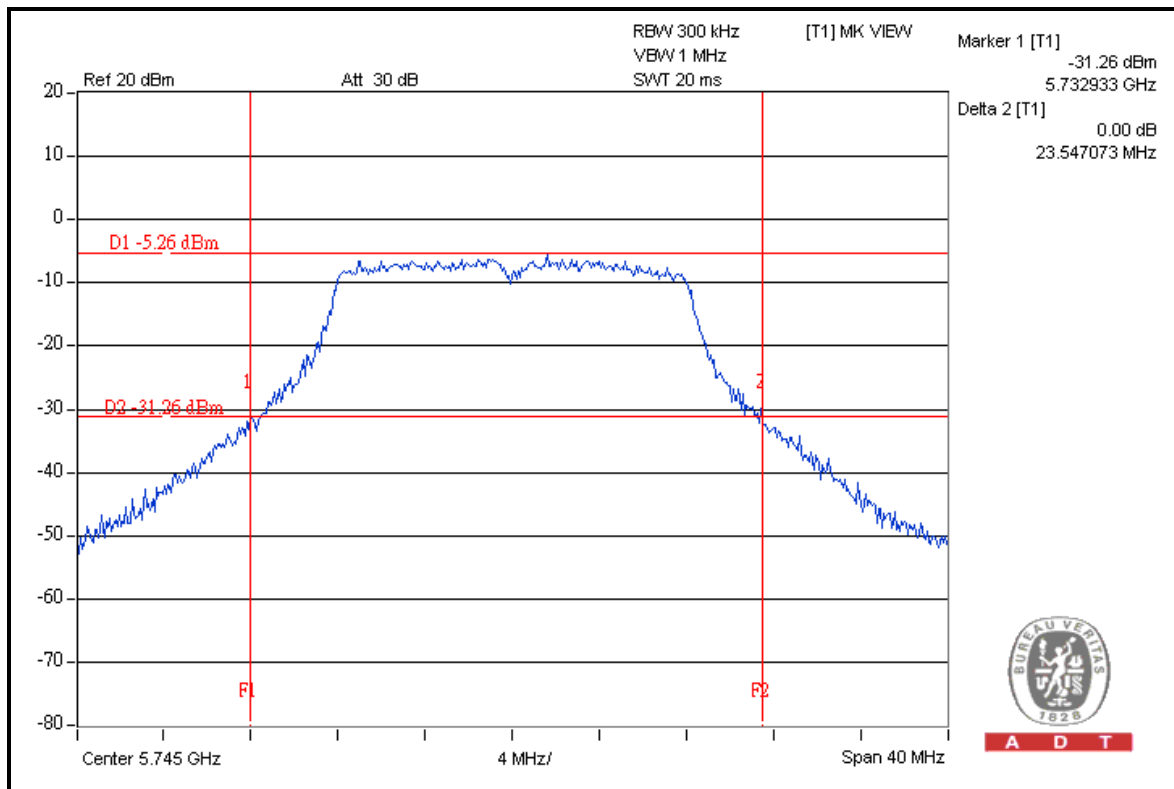



A D T

CH 157

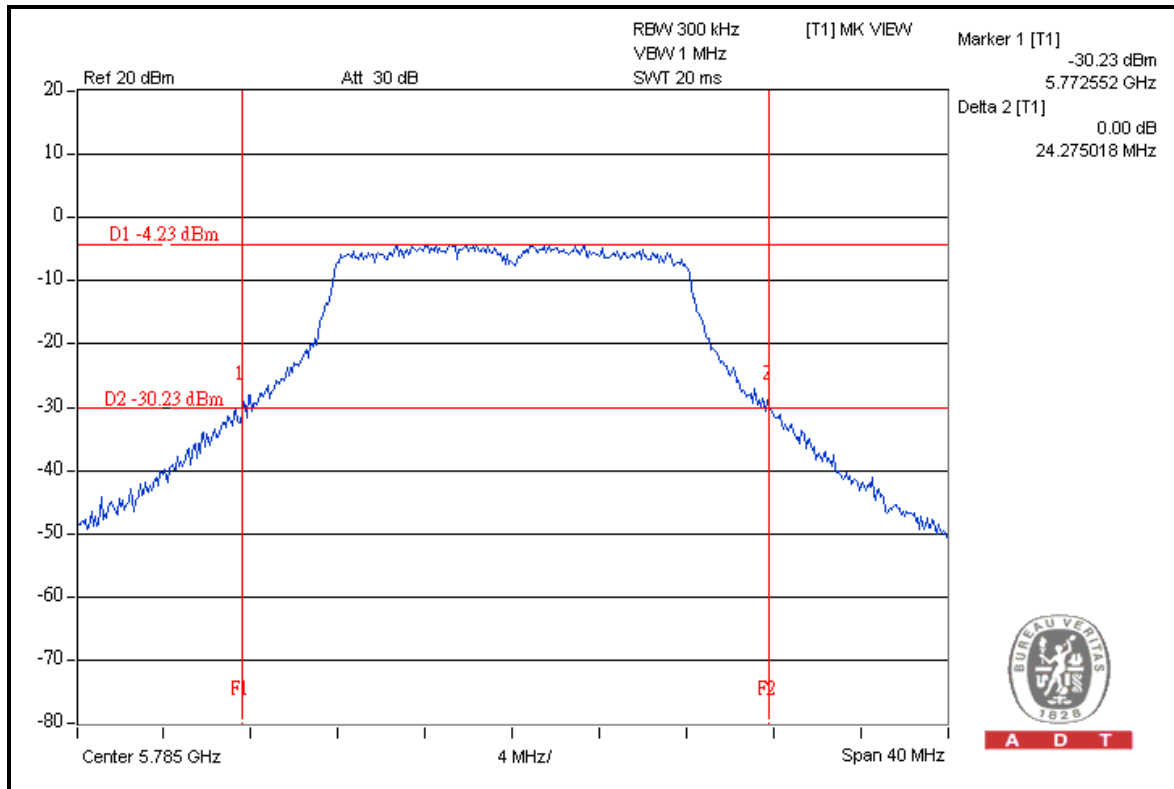

CH 165

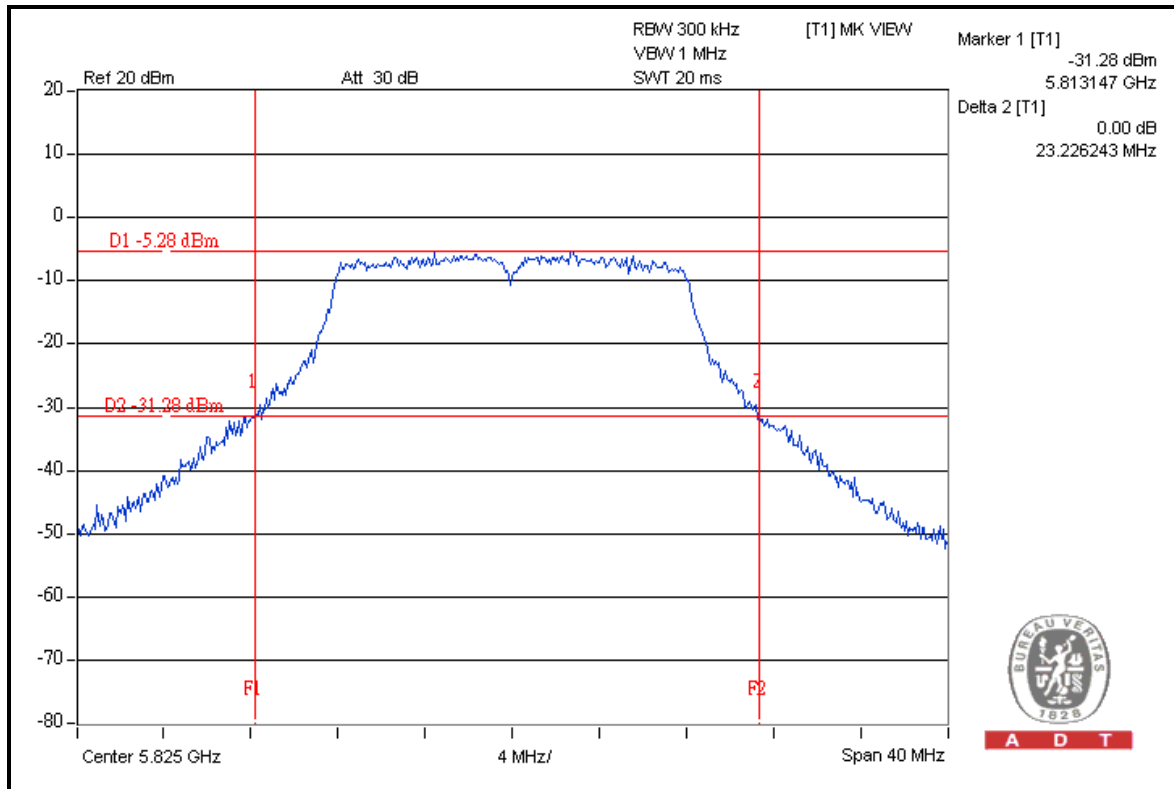



A D T

DRAFT 802.11n (40MHz) OFDM MODULATION

MODULATION TYPE	BPSK	TRANSFER RATE	13.5Mbps
INPUT POWER (SYSTEM)	120Vac, 60Hz	ENVIRONMENTAL CONDITIONS	25deg.C, 65% RH, 1010hPa
TESTED BY	Chad Lee	TEST MODE	A

CHANNEL	CHANNEL FREQUENCY (MHz)	26dBc OCCUPIED BANDWIDTH (MHz)		PASS / FAIL
		CHAIN 0	CHAIN 1	
151	5755	46.94	45.99	PASS
159	5795	46.73	46.62	PASS



A D T

FOR CHAIN 0: CH 151

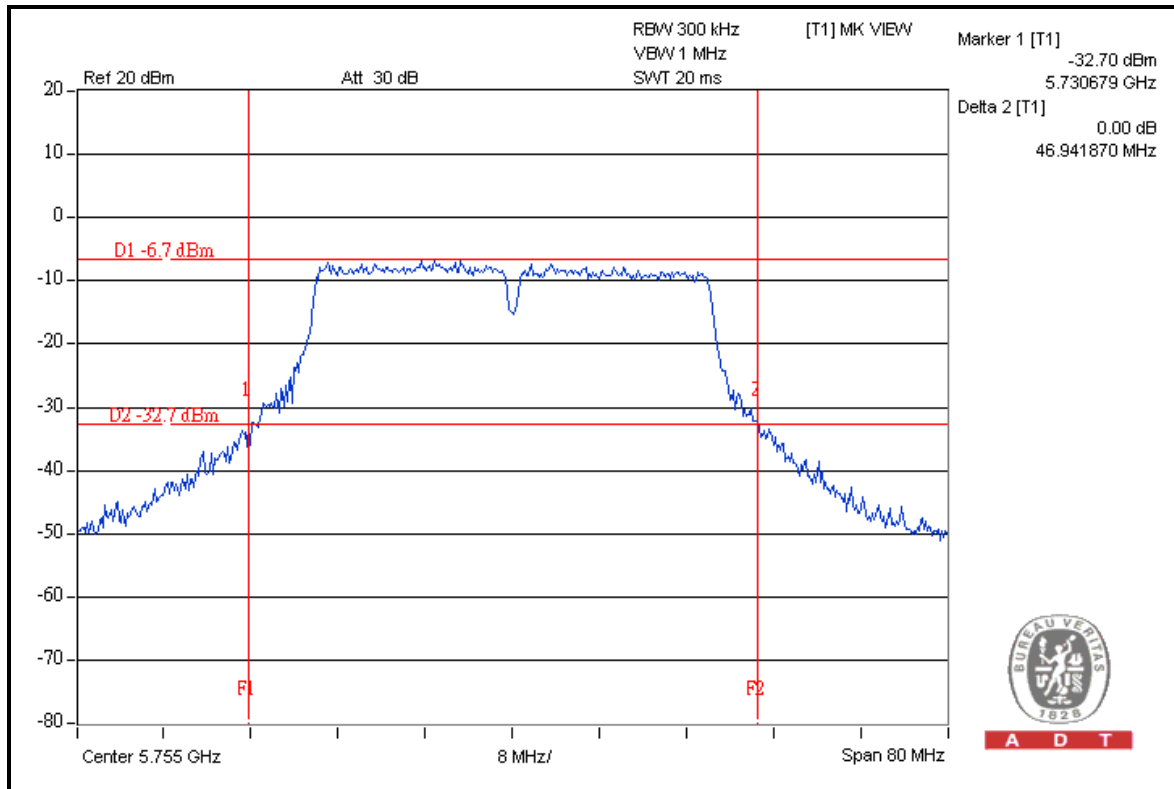

CH 159

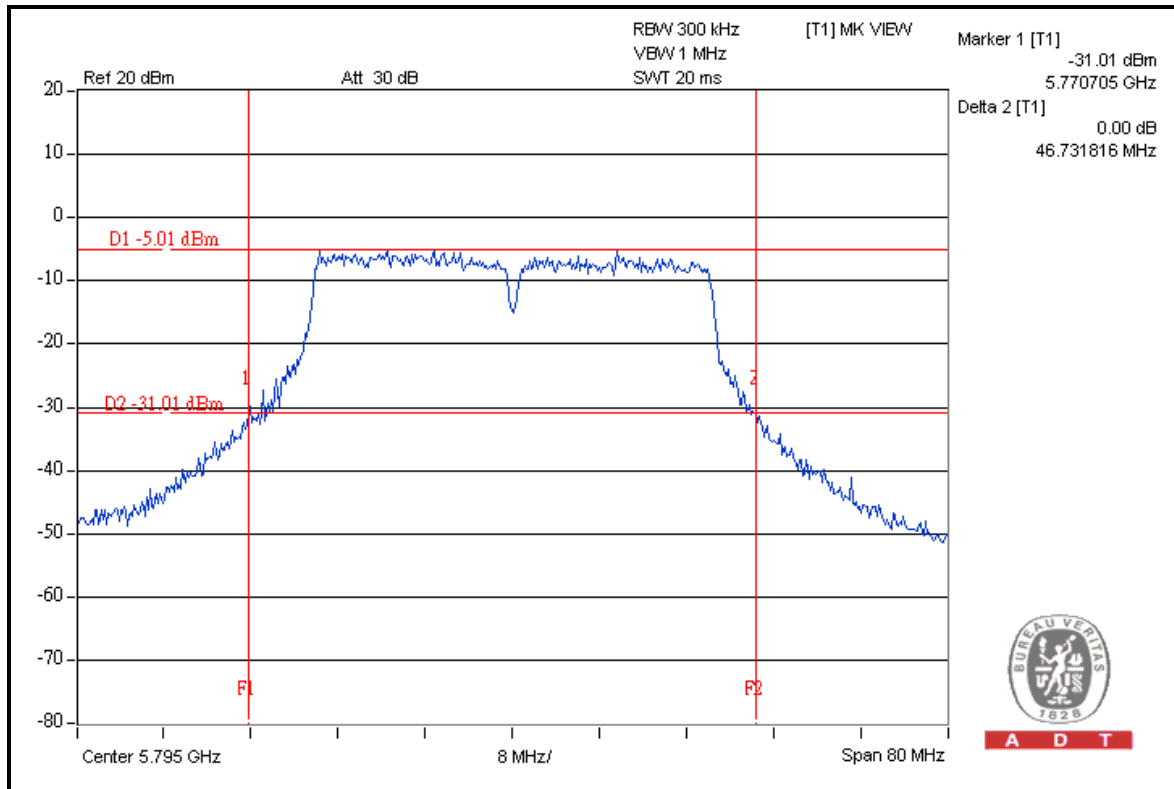



A D T

FOR CHAIN 1: CH 151

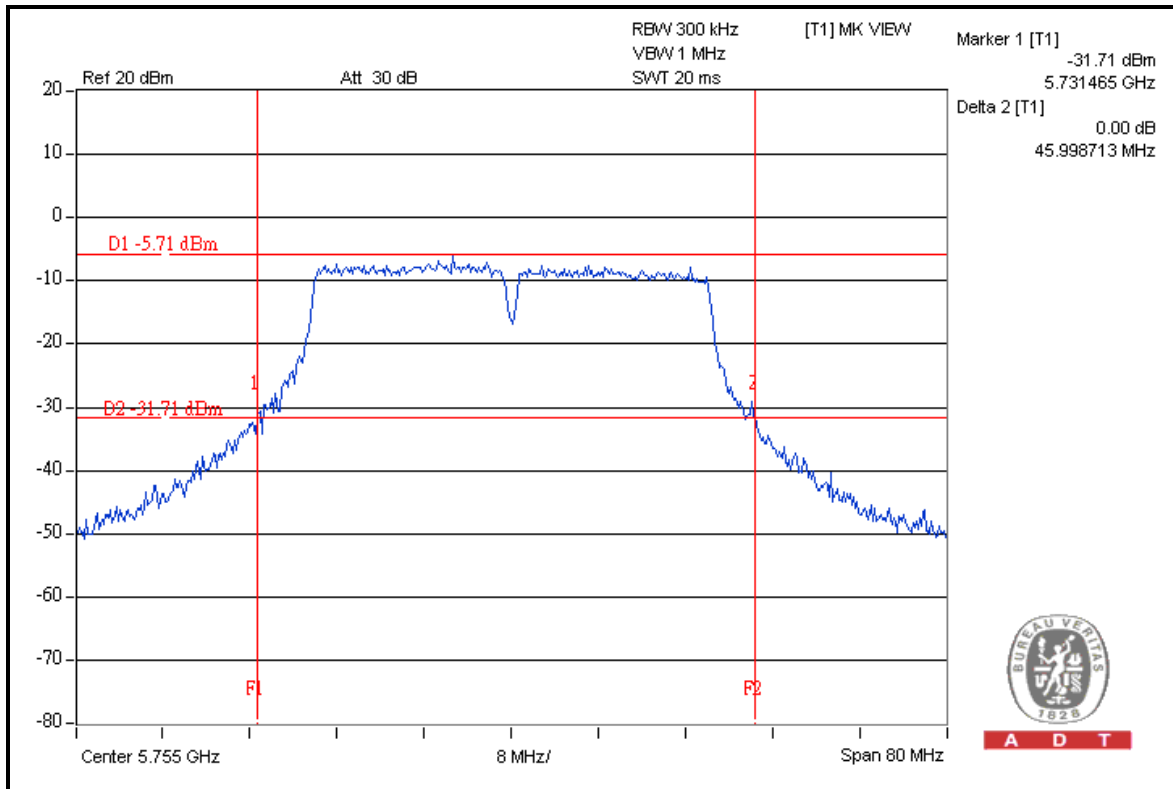

CH 159

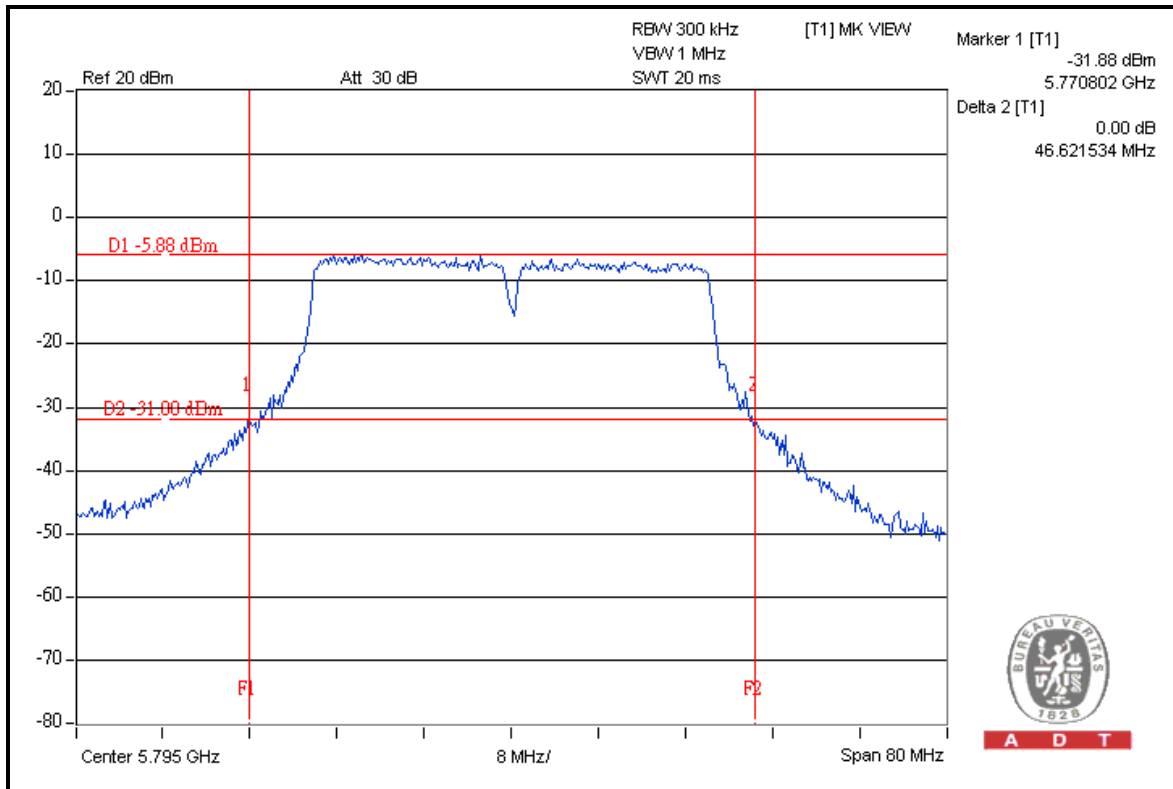



A D T

MODULATION TYPE	BPSK	TRANSFER RATE	13.5Mbps
INPUT POWER	120Vac, 60Hz	ENVIRONMENTAL CONDITIONS	25deg.C, 65% RH, 1010hPa
TESTED BY	Chad Lee	TEST MODE	C

CHANNEL	CHANNEL FREQUENCY (MHz)	26dBc OCCUPIED BANDWIDTH (MHz)		PASS / FAIL
		CHAIN 0	CHAIN 1	
151	5755	45.77	45.76	PASS
159	5795	45.62	45.78	PASS



A D T

FOR CHAIN 0: CH 151

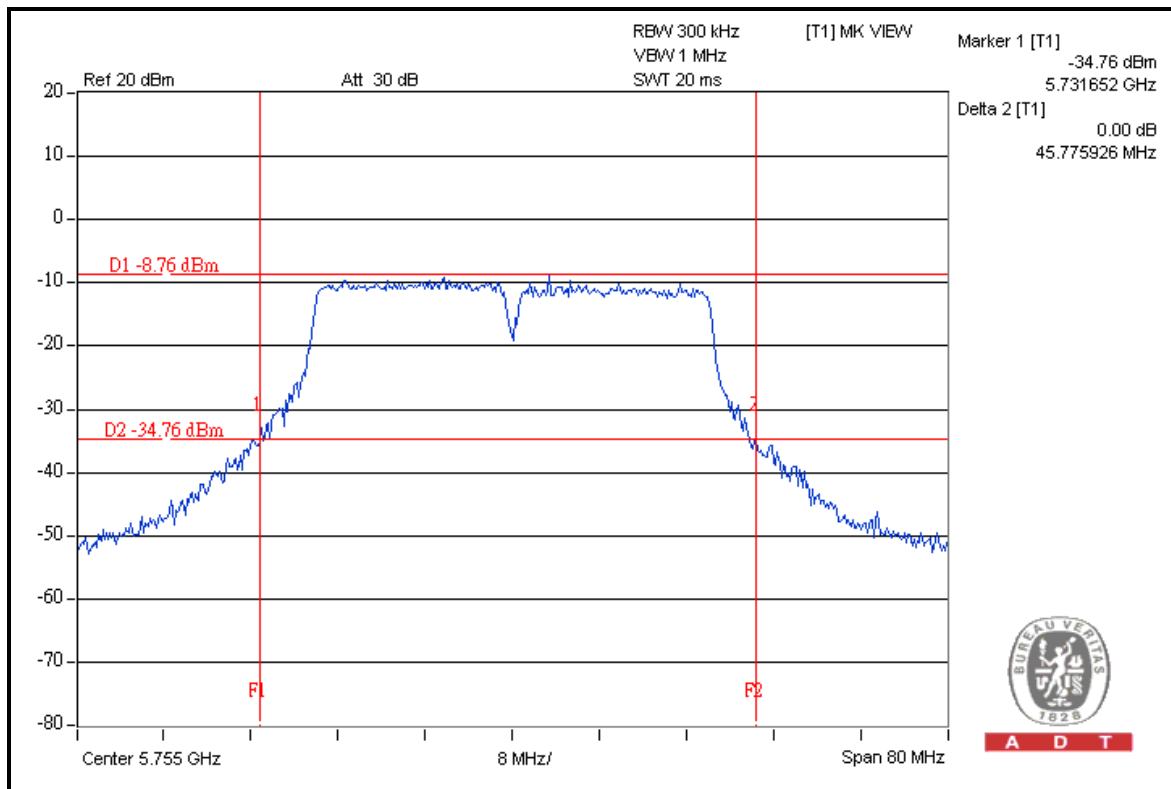

CH 159

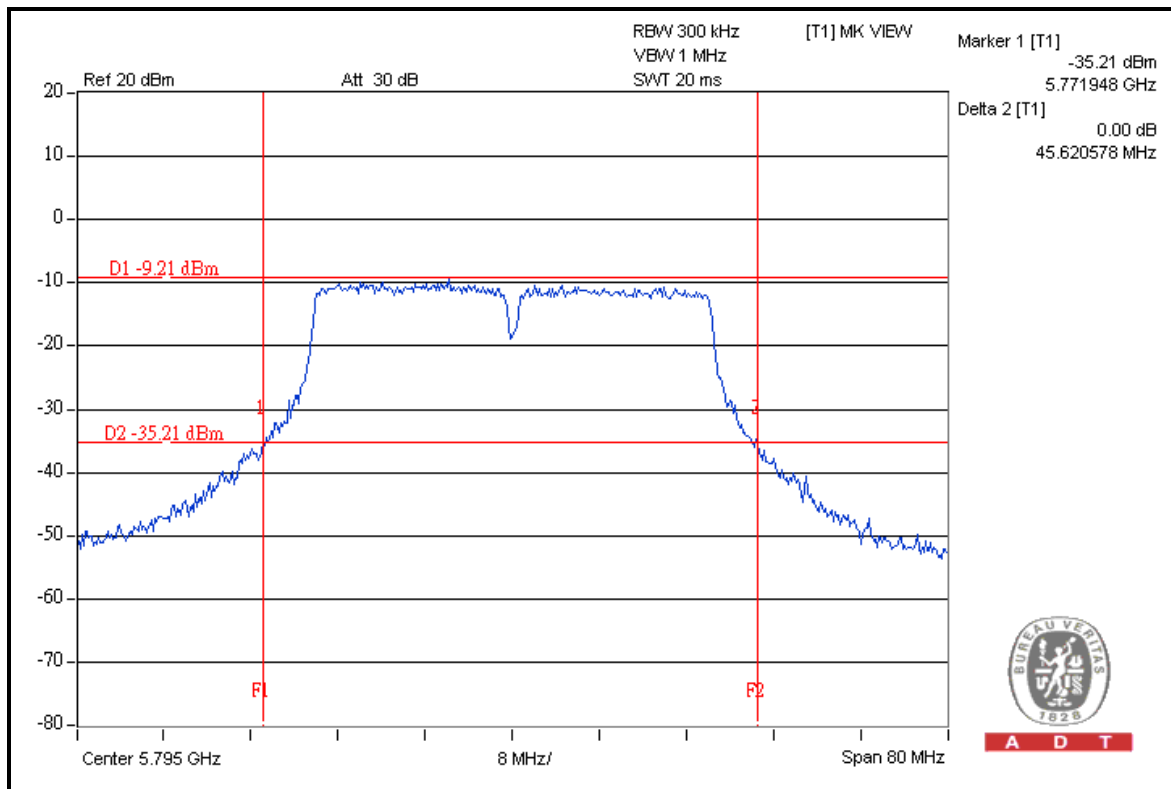



A D T

FOR CHAIN 1: CH 151

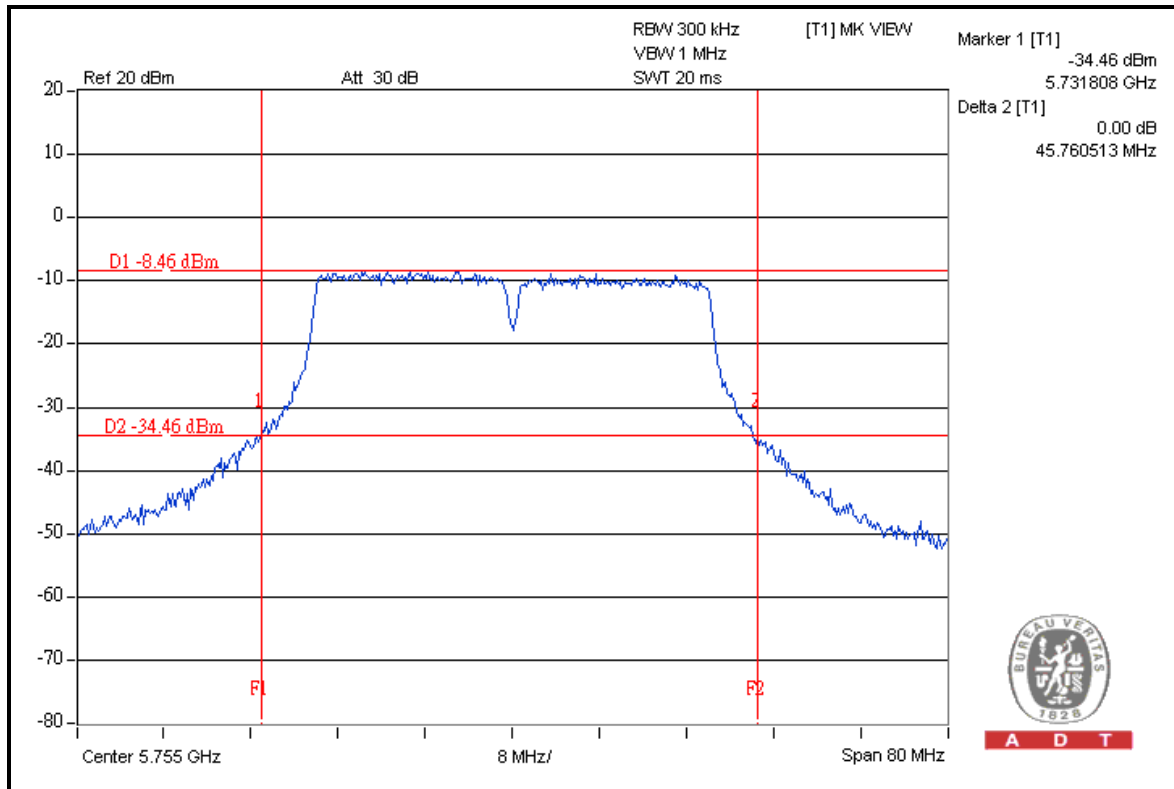

CH 159

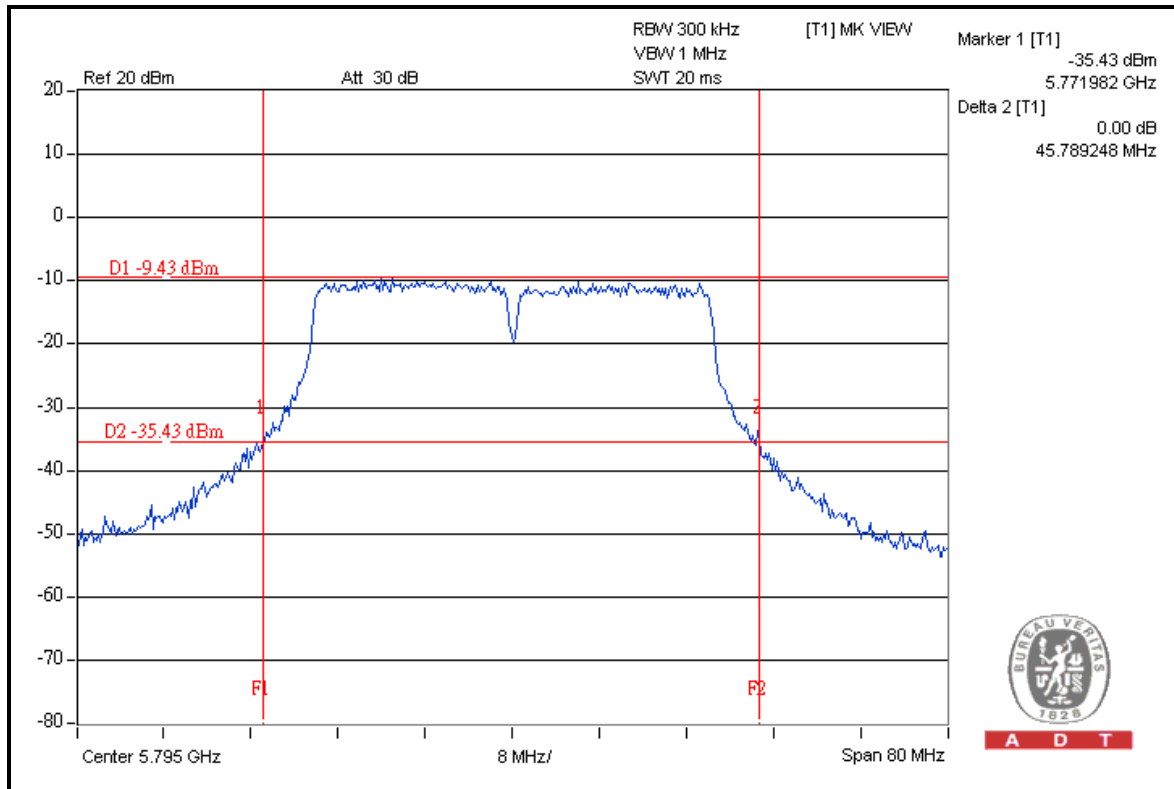



A D T

4.5 POWER SPECTRAL DENSITY MEASUREMENT

4.5.1 LIMITS OF POWER SPECTRAL DENSITY MEASUREMENT

The Maximum of Power Spectral Density Measurement is 8dBm.

4.5.2 TEST INSTRUMENTS

DESCRIPTION & MANUFACTURER	MODEL NO.	SERIAL NO.	DATE OF CALIBRATION	DUE DATE OF CALIBRATION
SPECTRUM ANALYZER	FSP 40	100036	Apr. 3, 2009	Apr. 2, 2010

NOTE: The calibration interval of the above test instruments is 12 months and the calibrations are traceable to NML/ROC and NIST/USA.

4.5.3 TEST PROCEDURE

1. Follow DTS measurement (PSD Option 2), the transmitter output was connected to the spectrum analyzer through an attenuator, the bandwidth of the fundamental frequency was measured with the spectrum analyzer. Locate and zoom in on emission peak(s) within the pass band.
2. Set RBW = 3 kHz /VBW > 9 kHz and sweep time to Automatic.
3. Detector use peak mode and a video trigger with the trigger level set to enable triggering only on full power pulses.
4. Trace average 100 traces in power averaging mode. The power spectral density was measured and recorded.



4.5.4 DEVIATION FROM TEST STANDARD

No deviation.

4.5.5 TEST SETUP

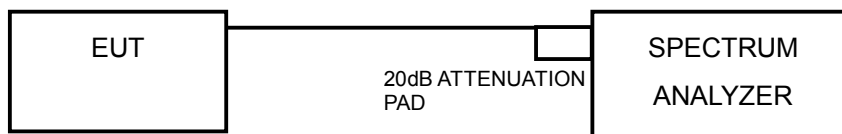

4.5.6 EUT OPERATING CONDITION

Same as Item 4.3.6.



A D T

4.5.7 TEST RESULTS

802.11a OFDM MODULATION

MODULATION TYPE	BPSK	TRANSFER RATE	6.0Mbps
INPUT POWER	120Vac, 60Hz	ENVIRONMENTAL CONDITIONS	25deg.C, 65% RH, 1010hPa
TESTED BY	Chad Lee	TEST MODE	A

CHAN.	CHAN. FREQ. (MHz)	RF POWER LEVEL IN 3kHz BW (dBm)		TOTAL POWER DENSITY (mW)	TOTAL POWER DENSITY (dBm)	MAX. LIMIT (dBm)	PASS / FAIL
		CHAIN 0	CHAIN 1				
149	5745	-15.11	-16.41	0.054	-12.70	0	PASS
157	5785	-13.03	-12.96	0.100	-9.98	0	PASS
165	5825	-16.31	-16.75	0.045	-13.51	0	PASS



A D T

FOR CHAIN 0: CH 149

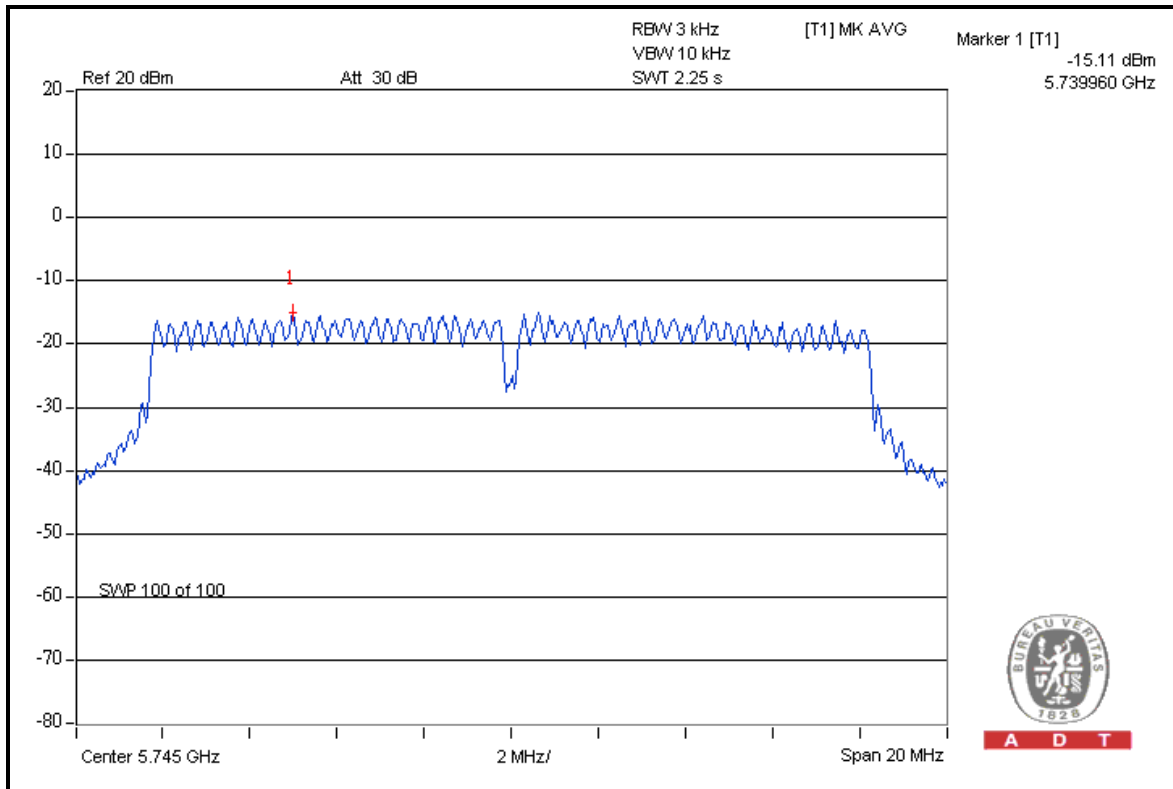

CH 157

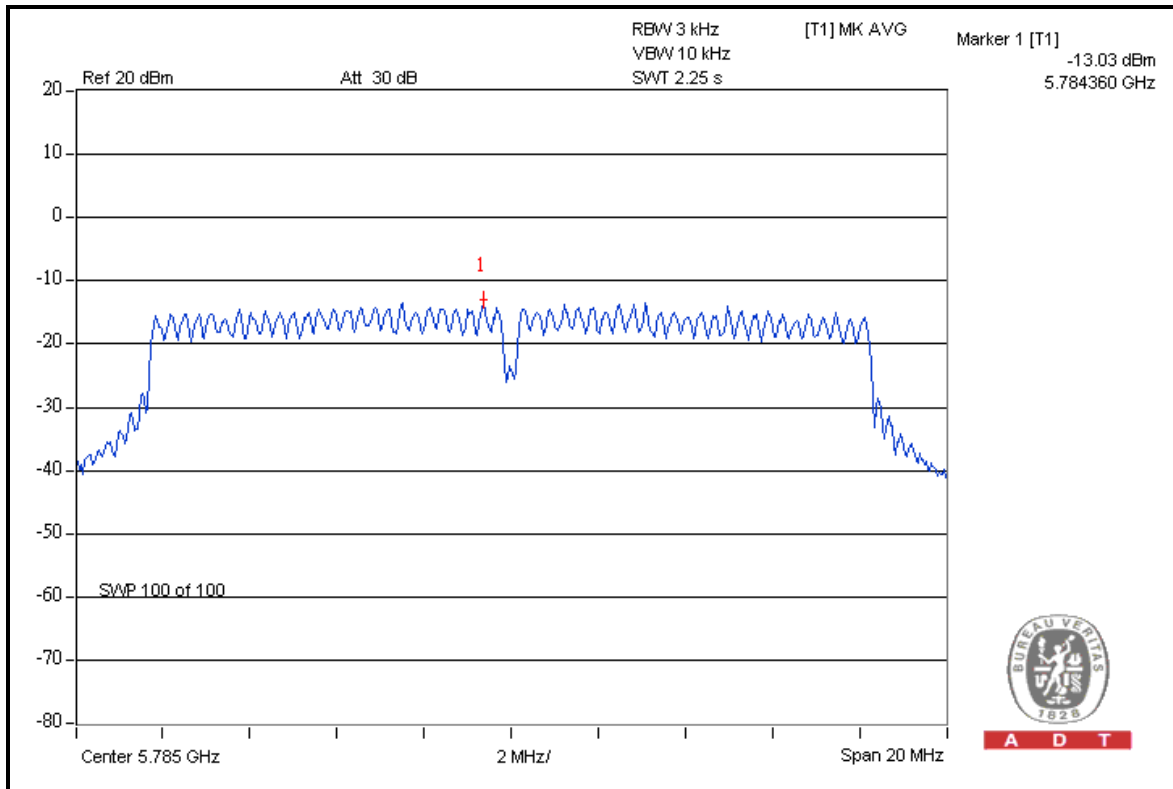



A D T

CH 165

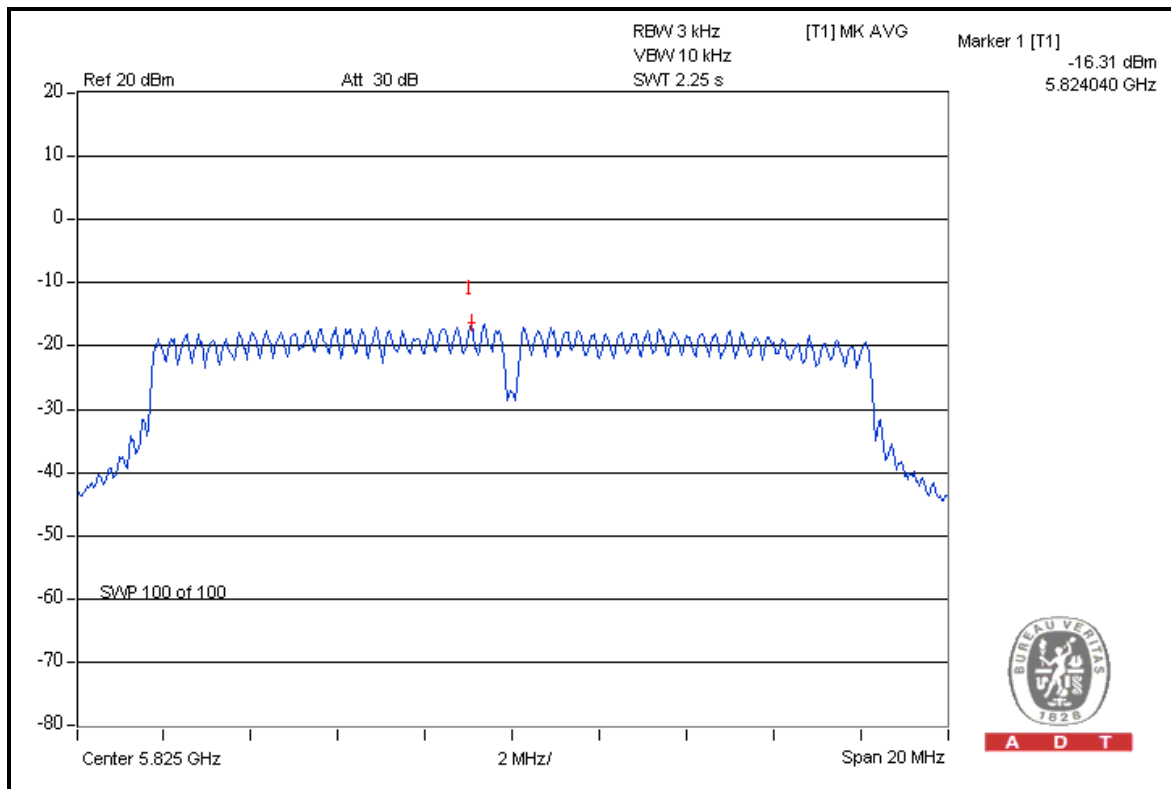

FOR CHAIN 1: CH 149

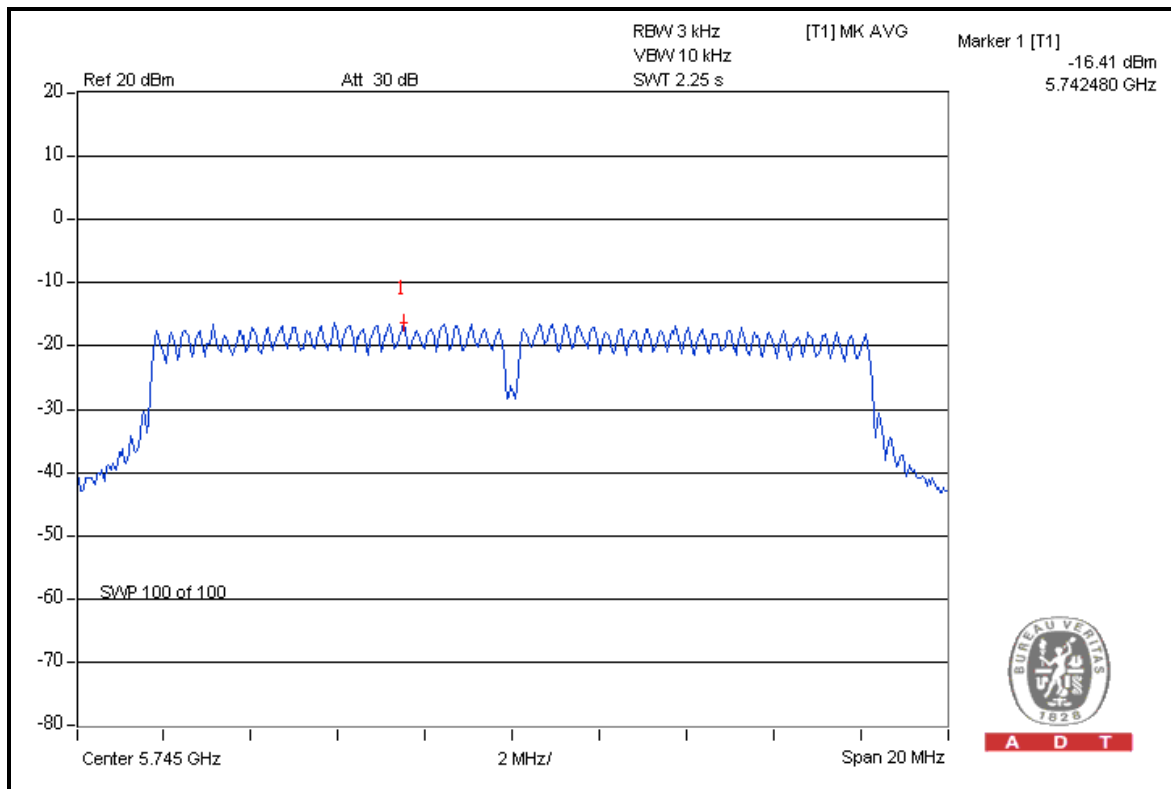



A D T

CH 157

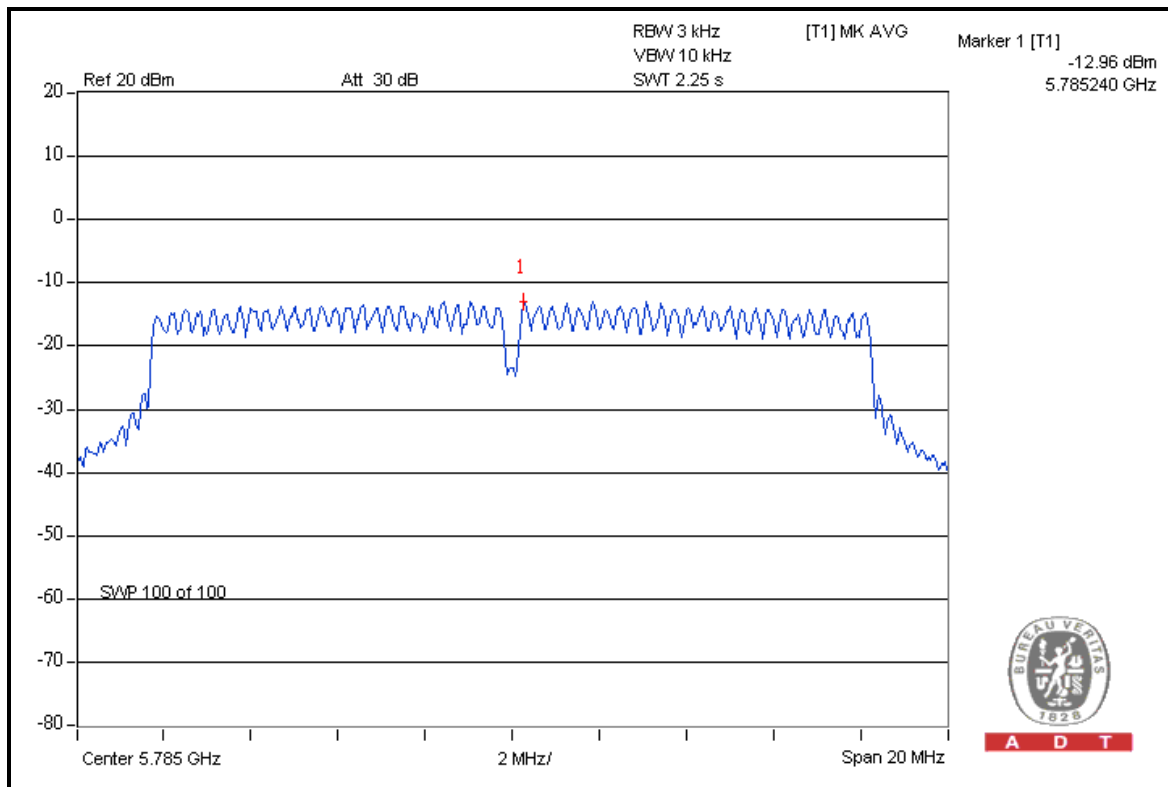

CH 165

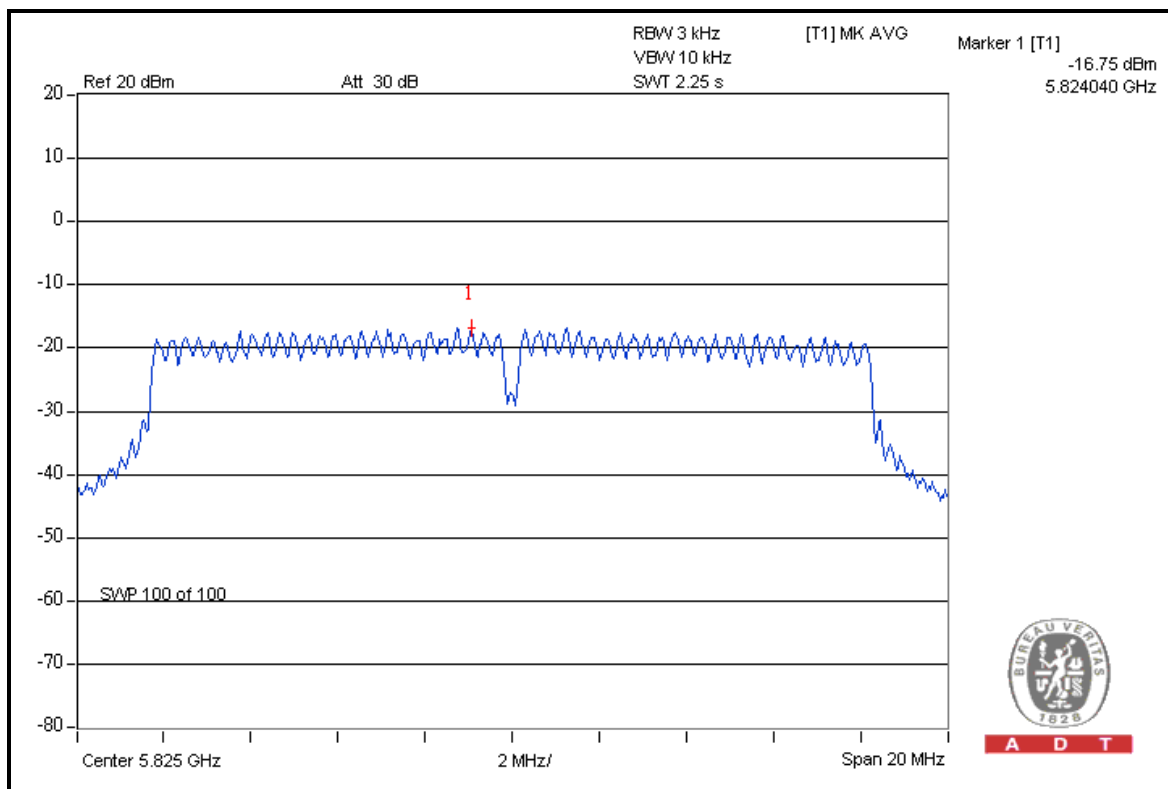



A D T

MODULATION TYPE	BPSK	TRANSFER RATE	6.0Mbps
INPUT POWER	120Vac, 60Hz	ENVIRONMENTAL CONDITIONS	25deg.C, 65% RH, 1010hPa
TESTED BY	Chad Lee	TEST MODE	C

CHAN.	CHAN. FREQ. (MHz)	RF POWER LEVEL IN 3kHz BW (dBm)		TOTAL POWER DENSITY (mW)	TOTAL POWER DENSITY (dBm)	MAX. LIMIT (dBm)	PASS / FAIL
		CHAIN 0	CHAIN 1				
149	5745	-19.85	-19.62	0.021	-16.72	-9	PASS
157	5785	-19.12	-18.69	0.026	-15.89	-9	PASS
165	5825	-21.56	-21.47	0.014	-18.50	-9	PASS



A D T

FOR CHAIN 0: CH 149

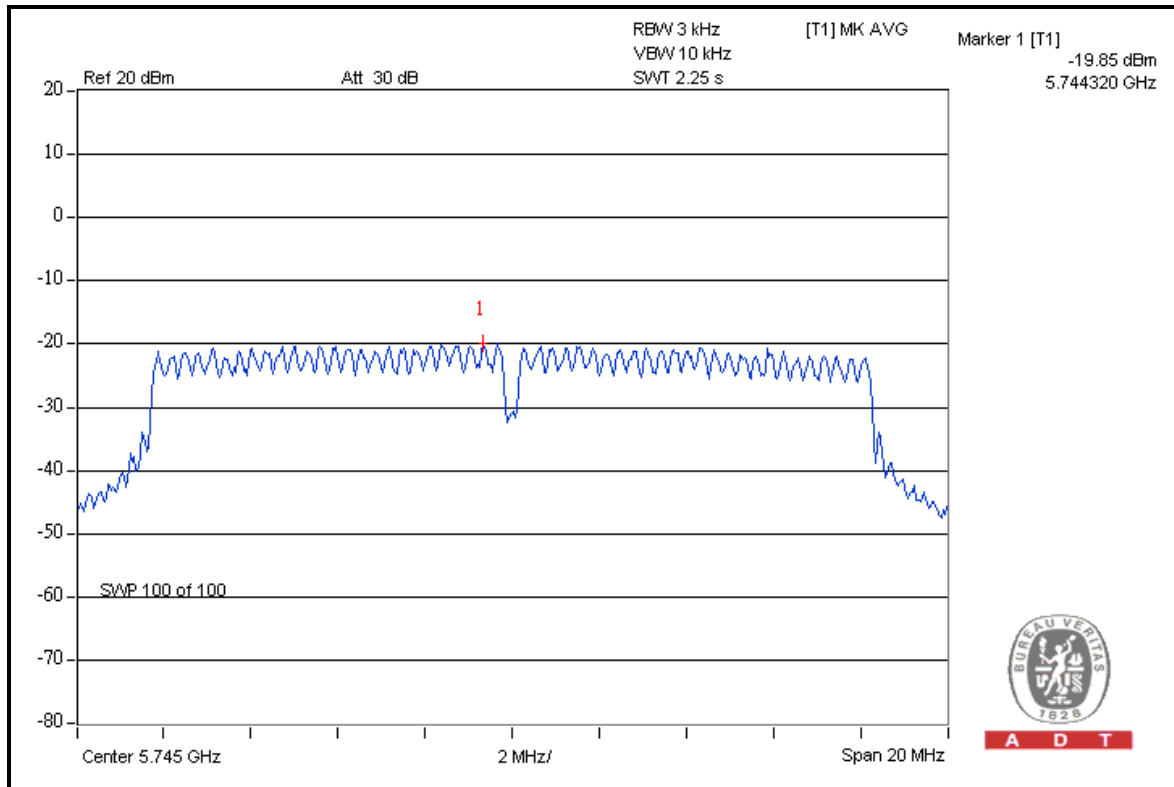

CH 157

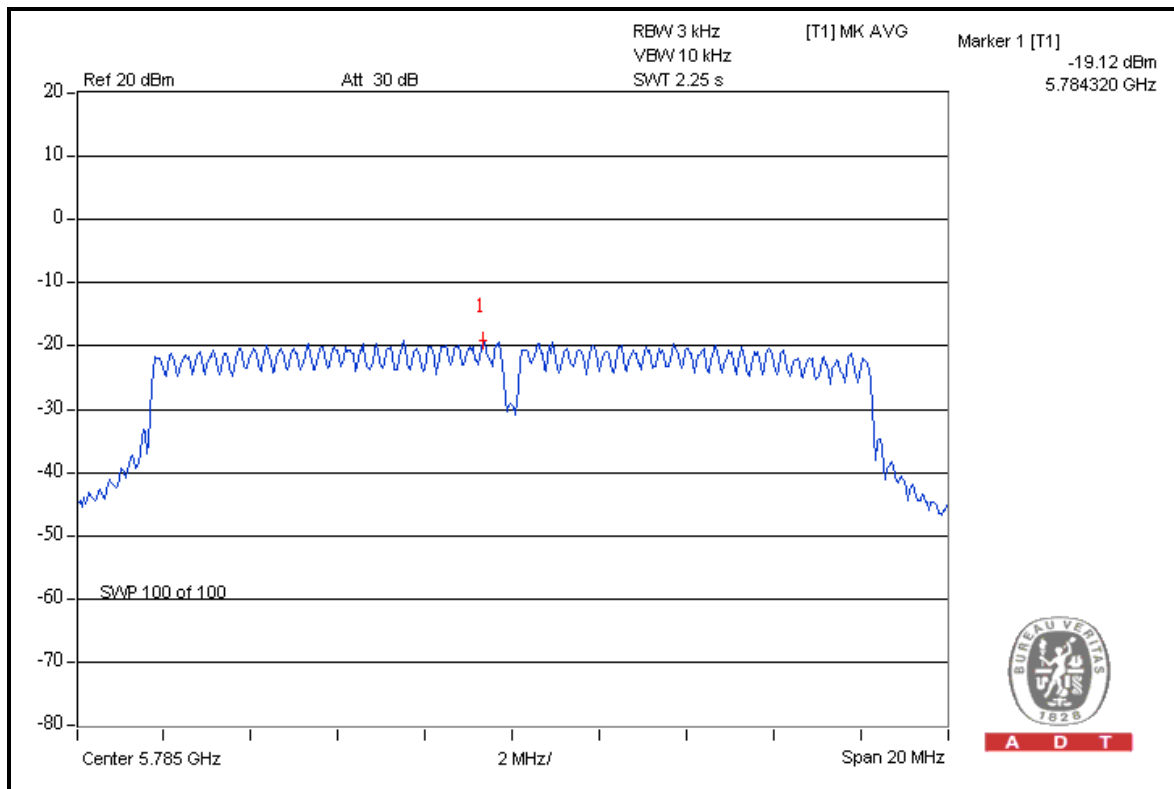



A D T

CH 165

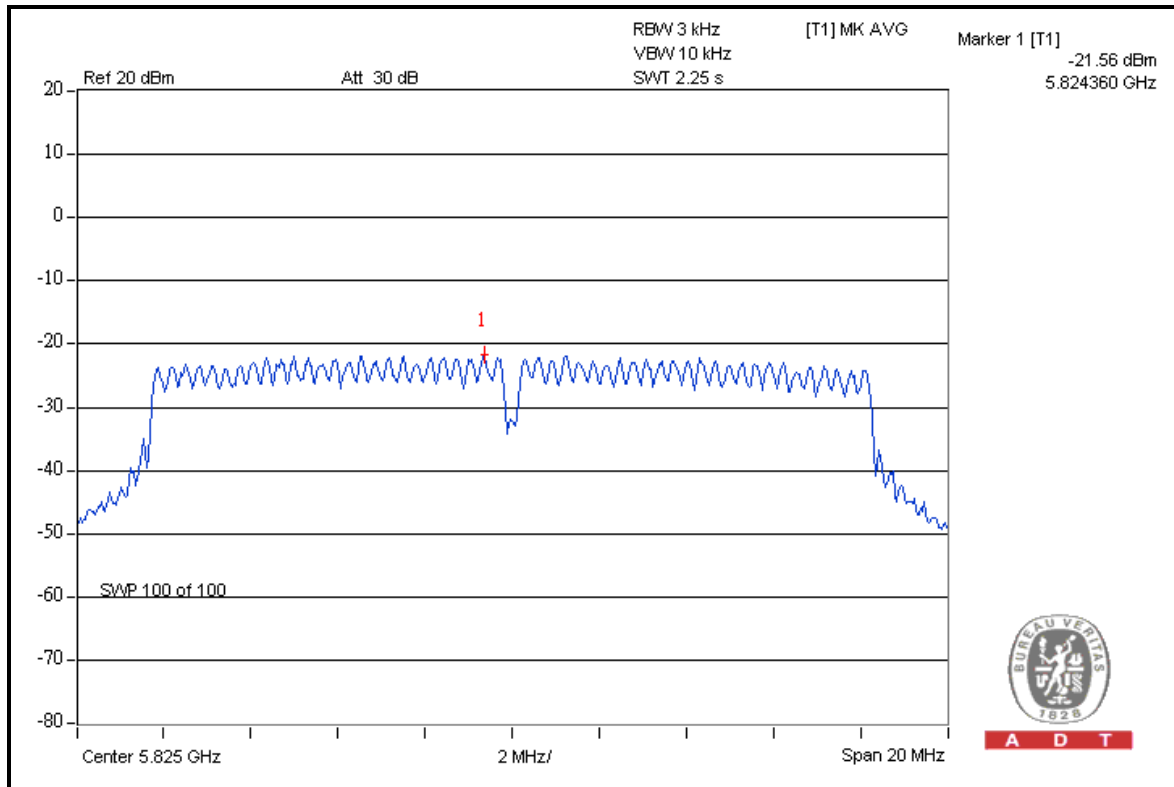

FOR CHAIN 1: CH 149

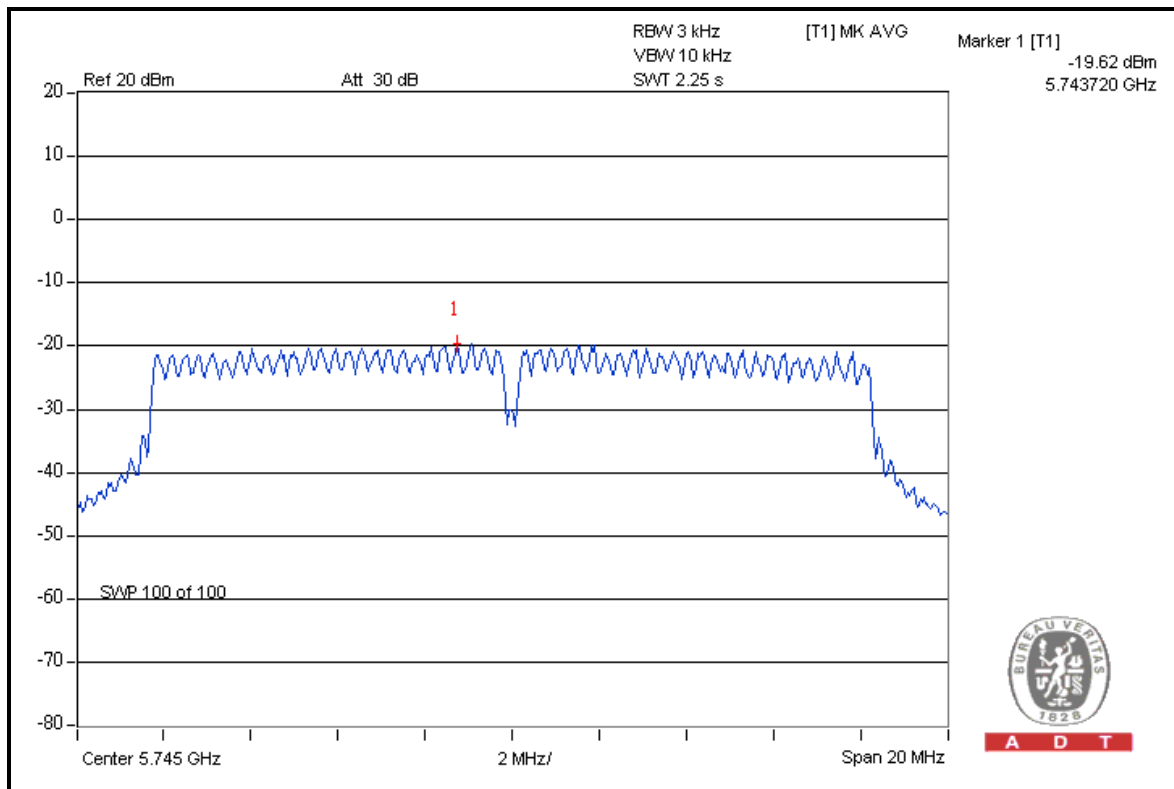



A D T

CH 157

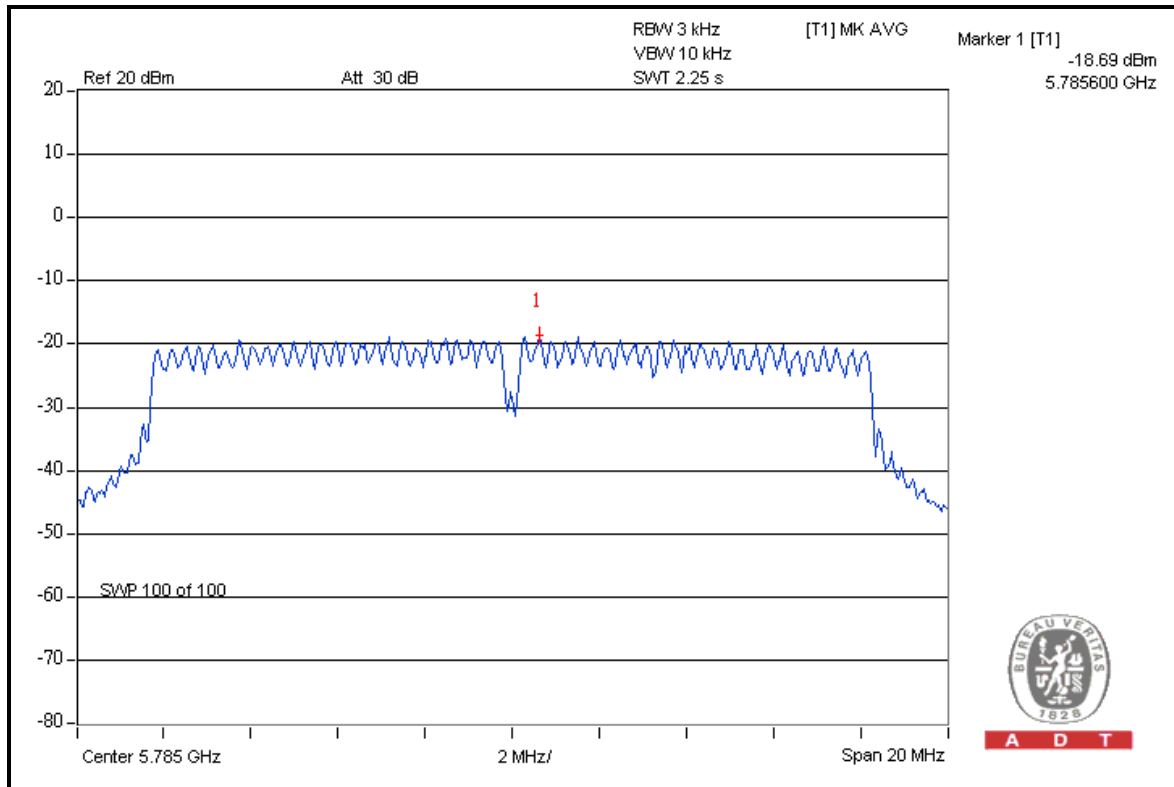

CH 165

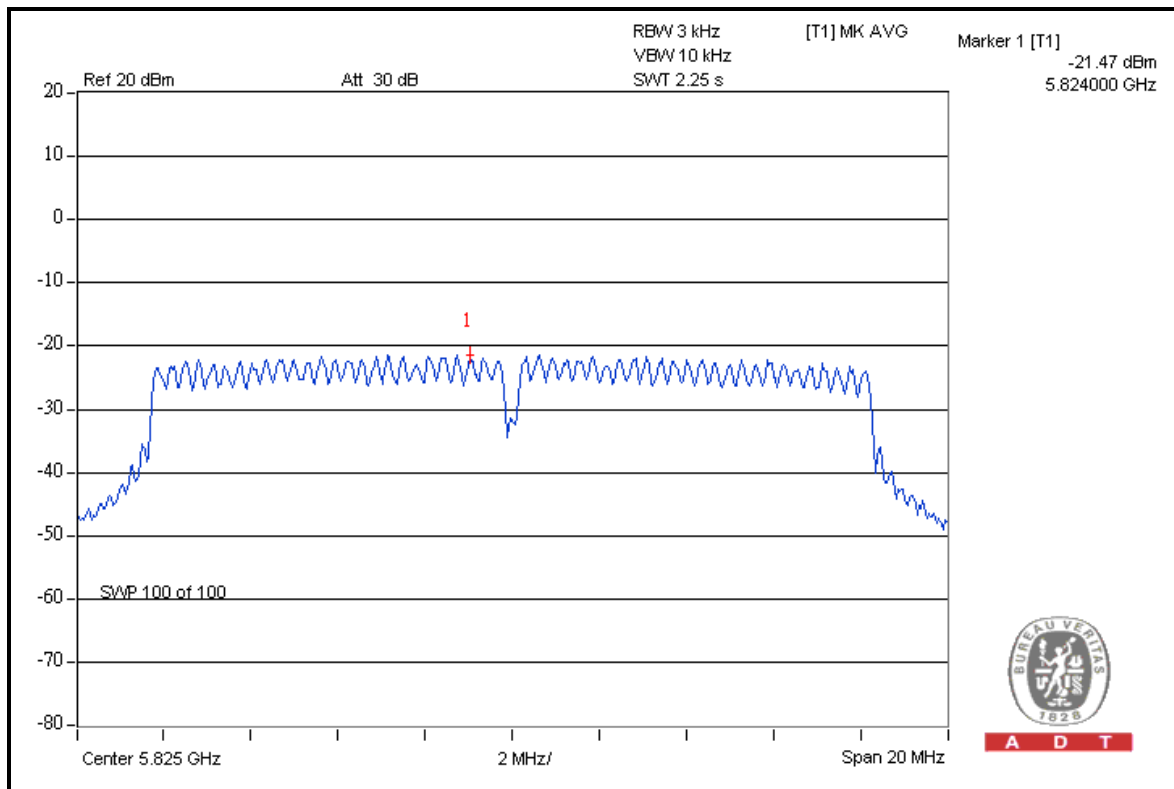



A D T

DRAFT 802.11n (20MHz) OFDM MODULATION

MODULATION TYPE	BPSK	TRANSFER RATE	6.5Mbps
INPUT POWER	120Vac, 60Hz	ENVIRONMENTAL CONDITIONS	25deg.C, 65% RH, 1010hPa
TESTED BY	Chad Lee	TEST MODE	A

CHAN.	CHAN. FREQ. (MHz)	RF POWER LEVEL IN 3kHz BW (dBm)		TOTAL POWER DENSITY (mW)	TOTAL POWER DENSITY (dBm)	MAX. LIMIT (dBm)	PASS / FAIL
		CHAIN 0	CHAIN 1				
149	5745	-13.44	-14.51	0.081	-10.93	0	PASS
157	5785	-10.77	-10.92	0.165	-7.83	0	PASS
165	5825	-12.72	-14.82	0.086	-10.63	0	PASS



A D T

FOR CHAIN 0: CH 149

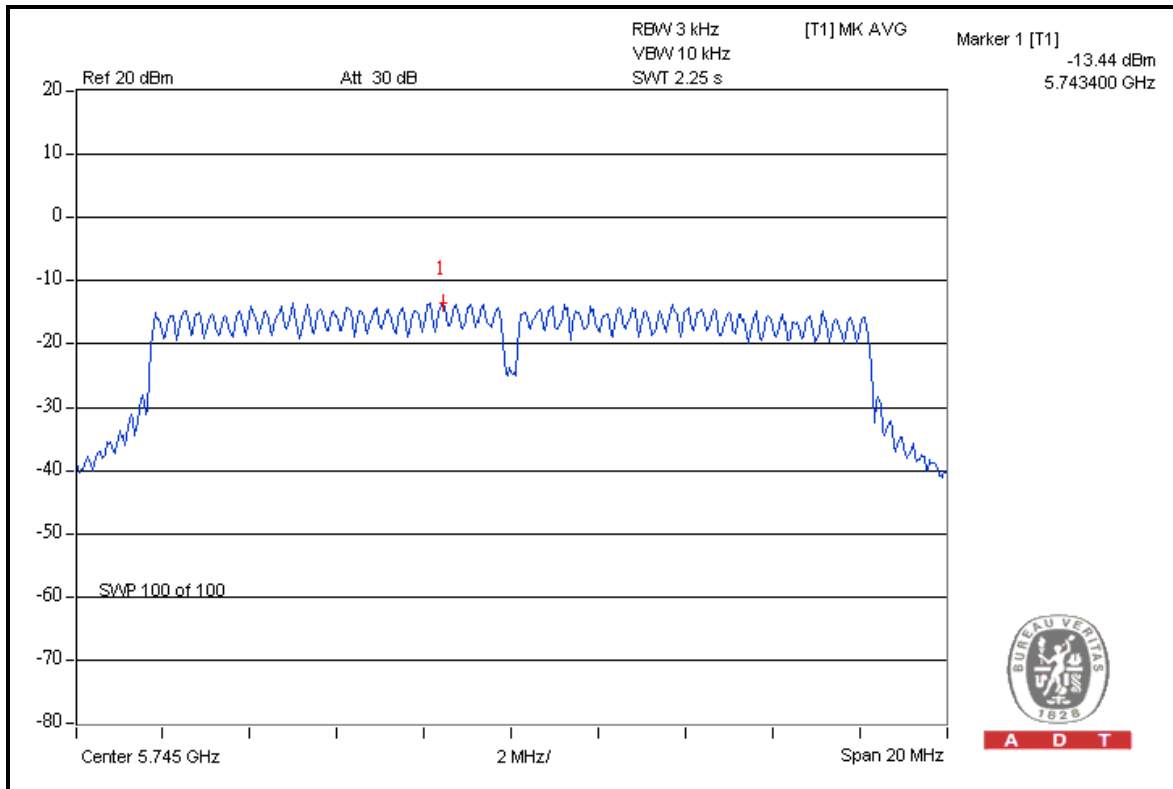

CH 157

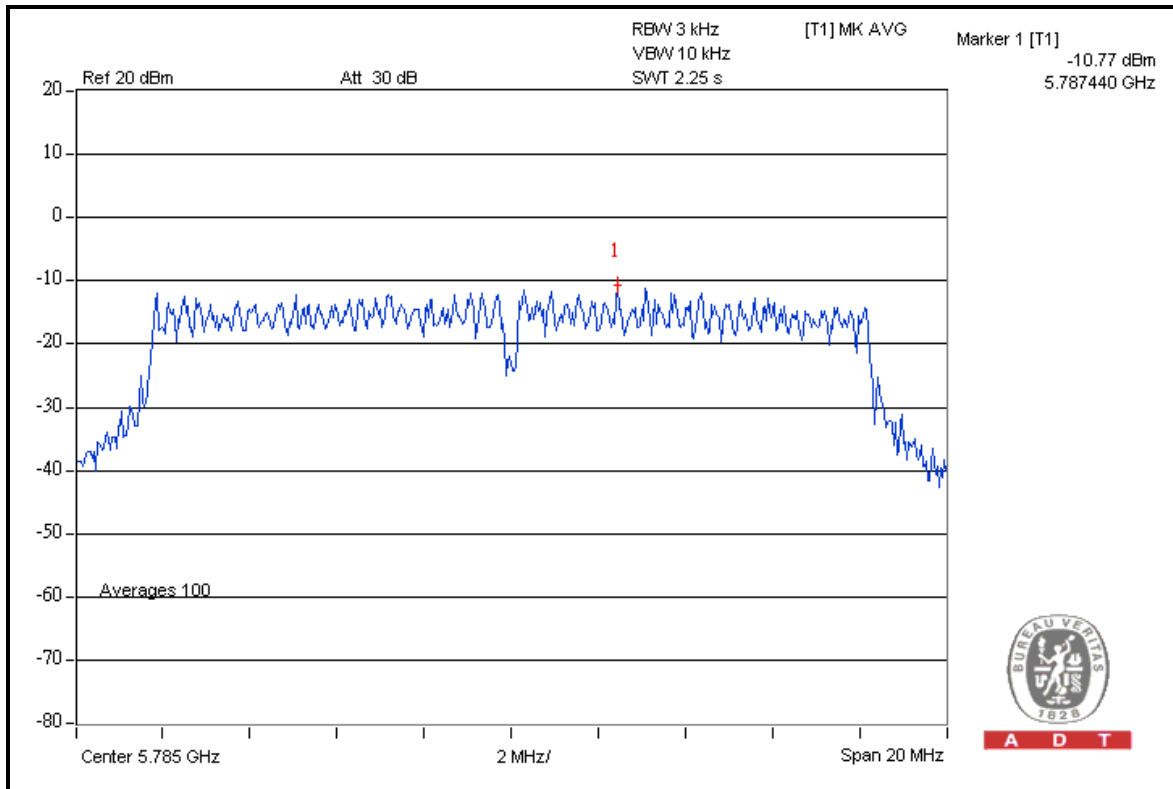



A D T

CH 165

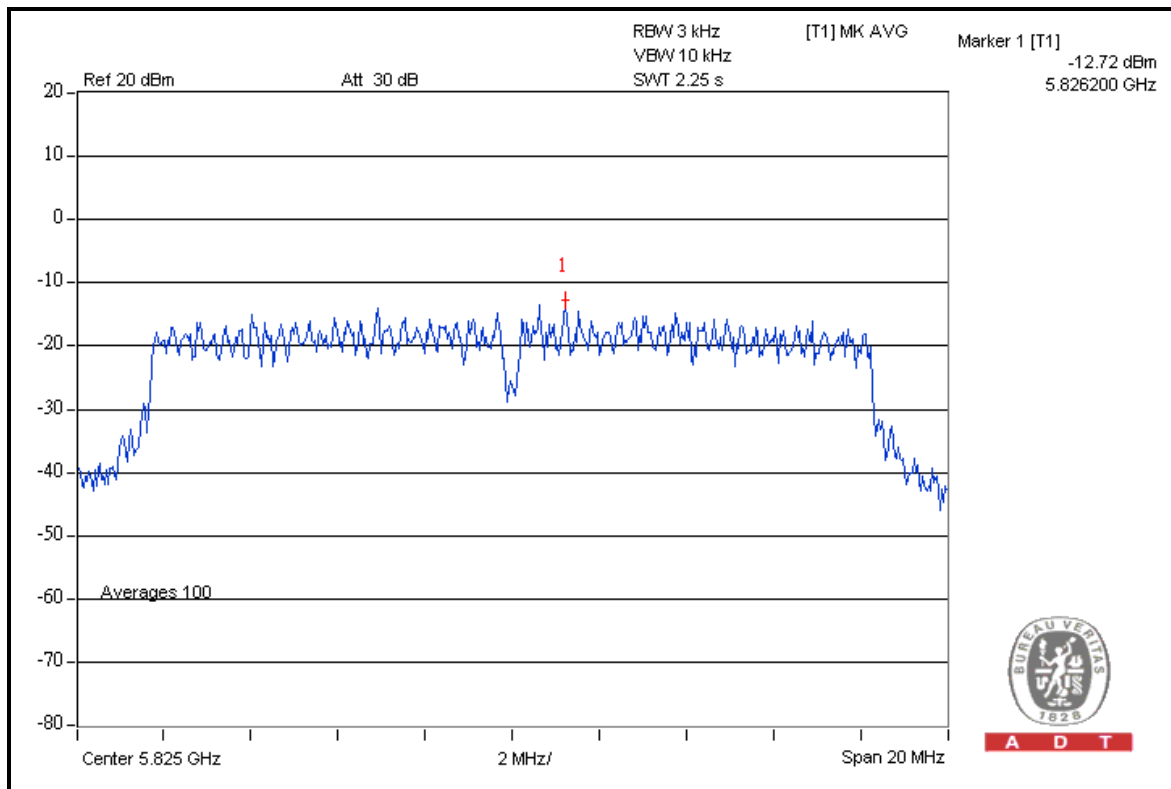

FOR CHAIN 1: CH 149

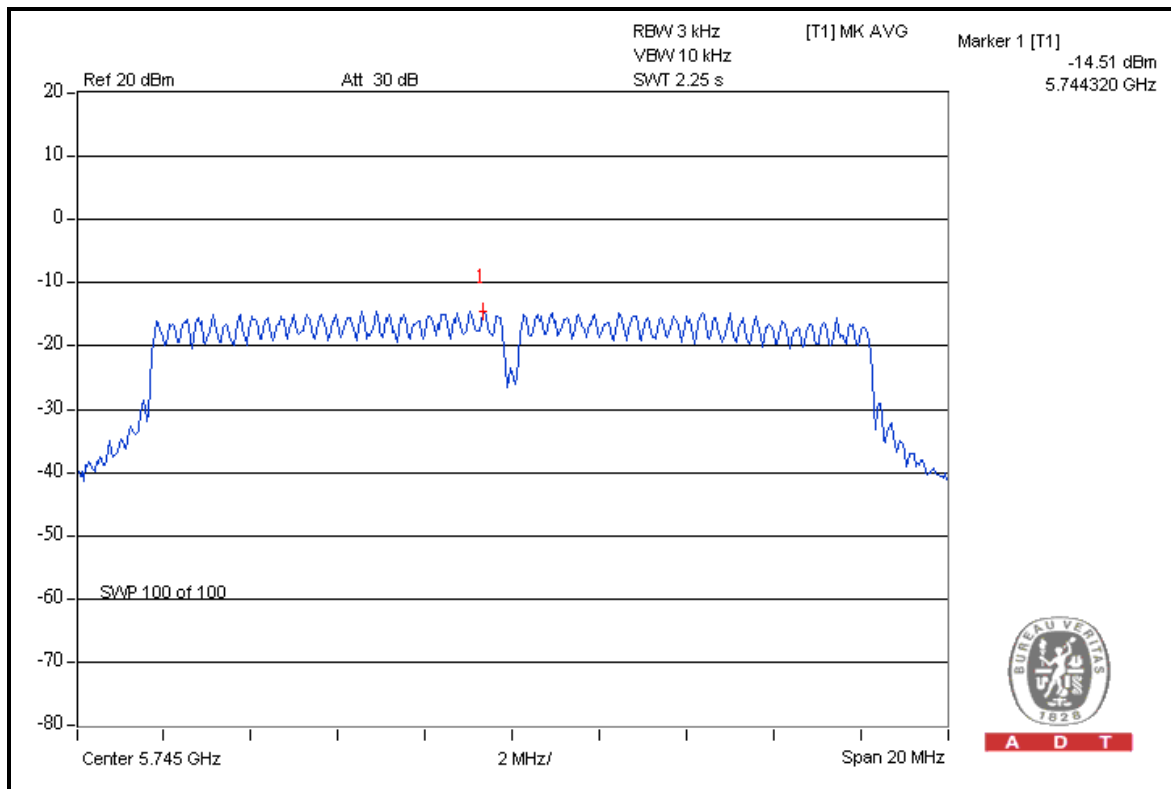



A D T

CH 157

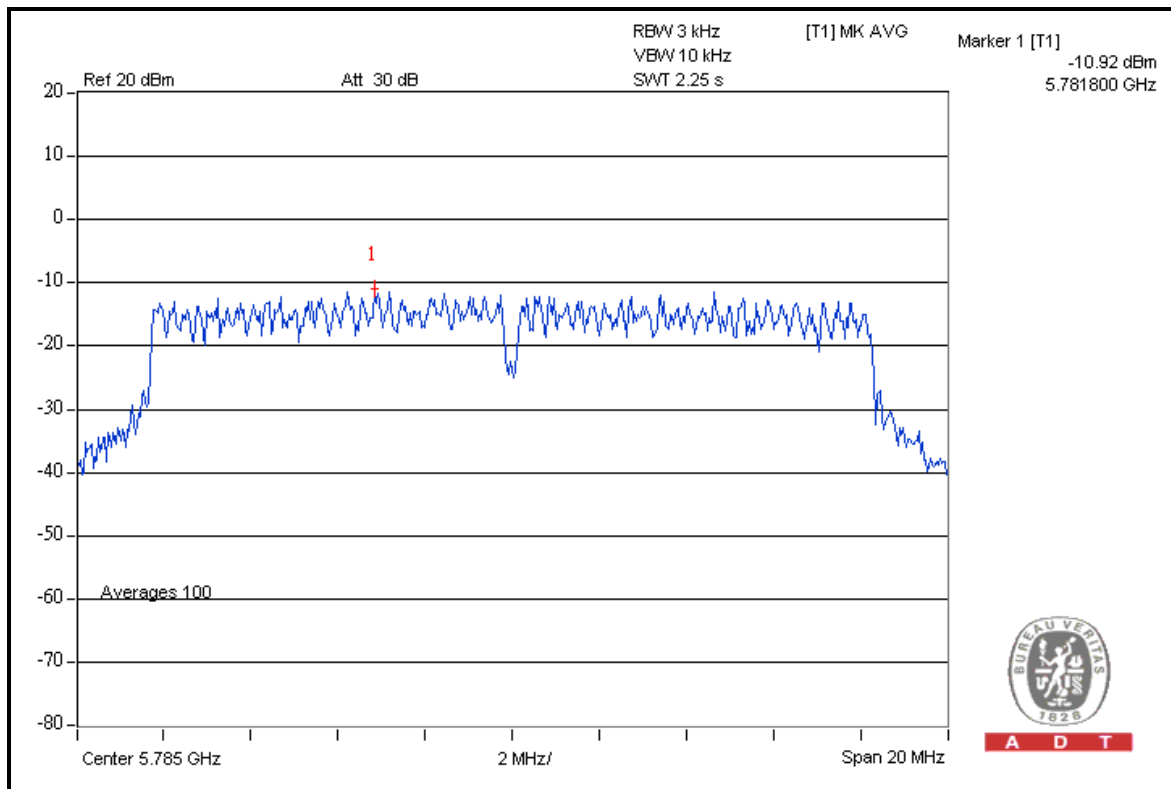

A D T

CH 165

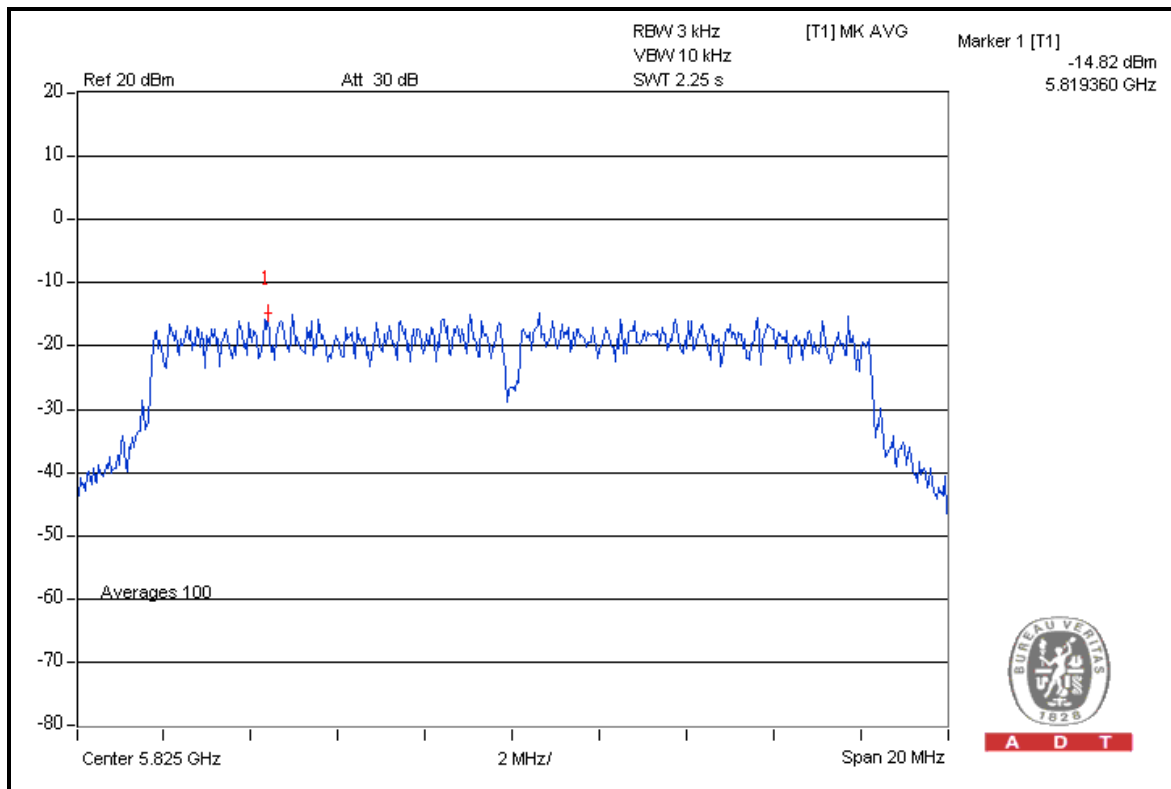

A D T



A D T

MODULATION TYPE	BPSK	TRANSFER RATE	6.5Mbps
INPUT POWER	120Vac, 60Hz	ENVIRONMENTAL CONDITIONS	25deg.C, 65% RH, 1010hPa
TESTED BY	Chad Lee	TEST MODE	C

CHAN.	CHAN. FREQ. (MHz)	RF POWER LEVEL IN 3kHz BW (dBm)		TOTAL POWER DENSITY (mW)	TOTAL POWER DENSITY (dBm)	MAX. LIMIT (dBm)	PASS / FAIL
		CHAIN 0	CHAIN 1				
149	5745	-19.29	-19.56	0.023	-16.41	-9	PASS
157	5785	-18.59	-18.60	0.028	-15.58	-9	PASS
165	5825	-21.21	-20.90	0.016	-18.04	-9	PASS



A D T

FOR CHAIN 0: CH 149

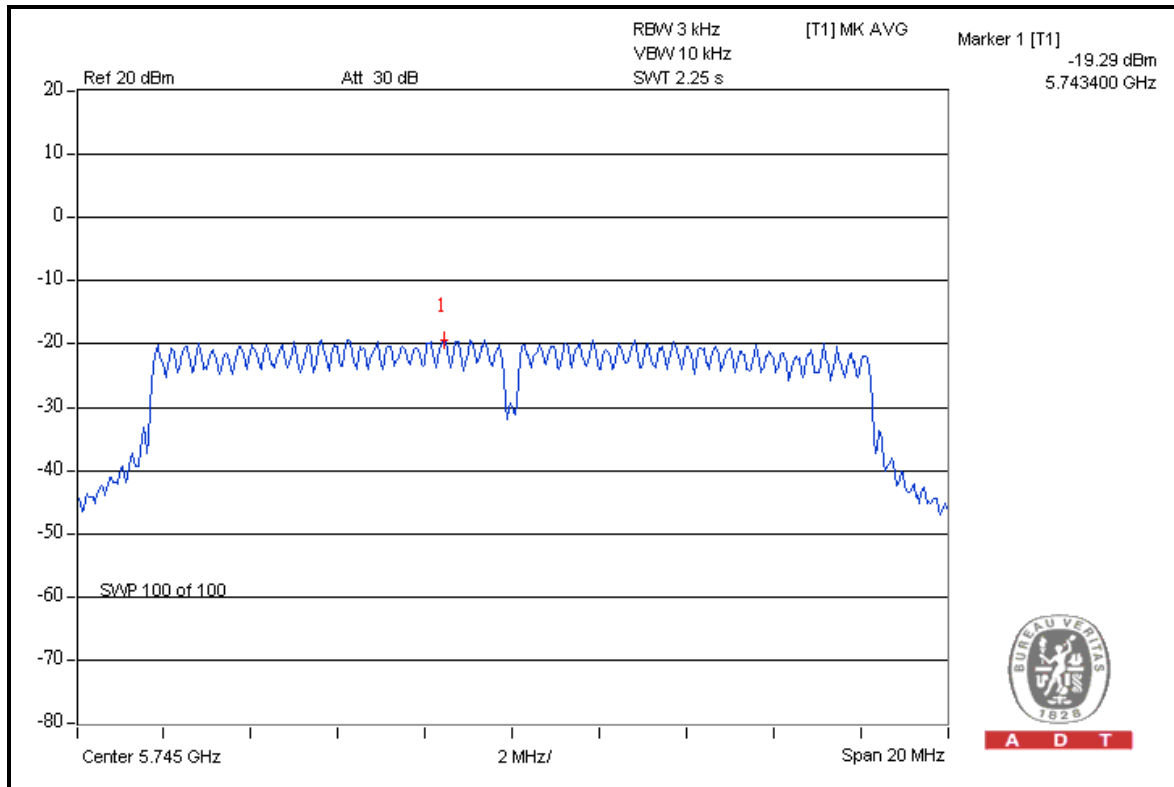

CH 157

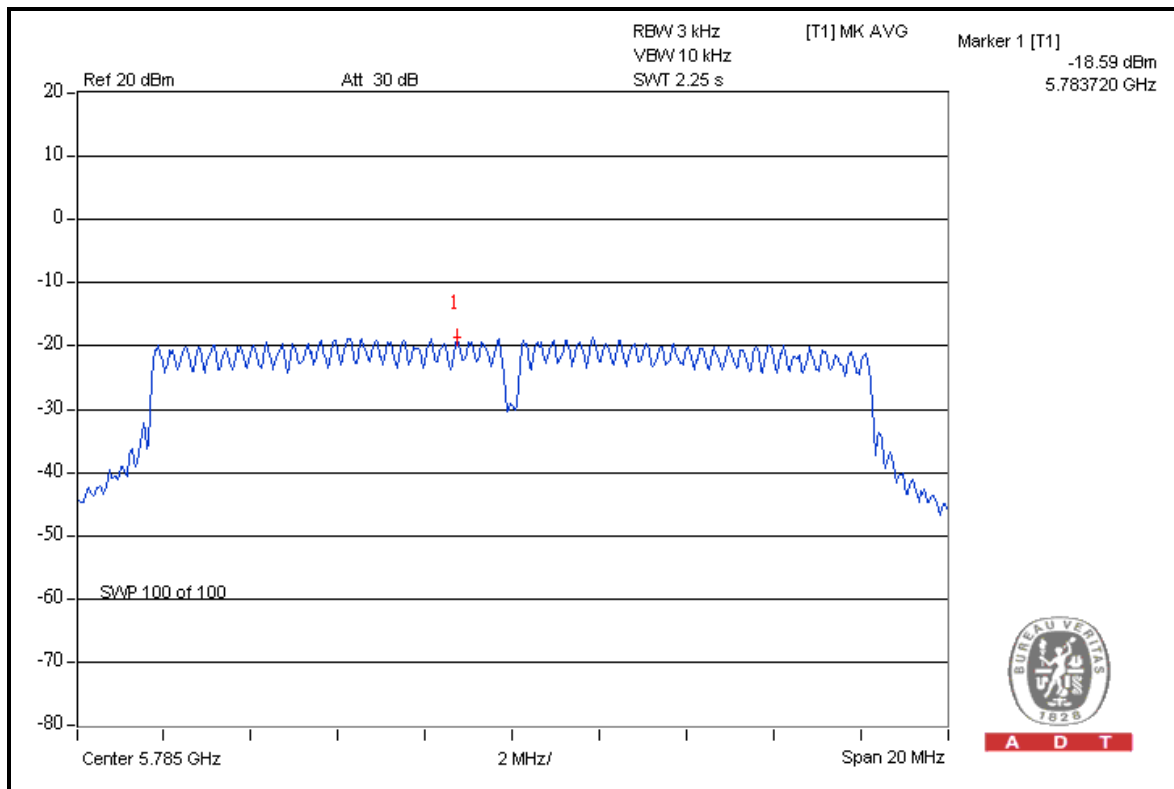



A D T

CH 165

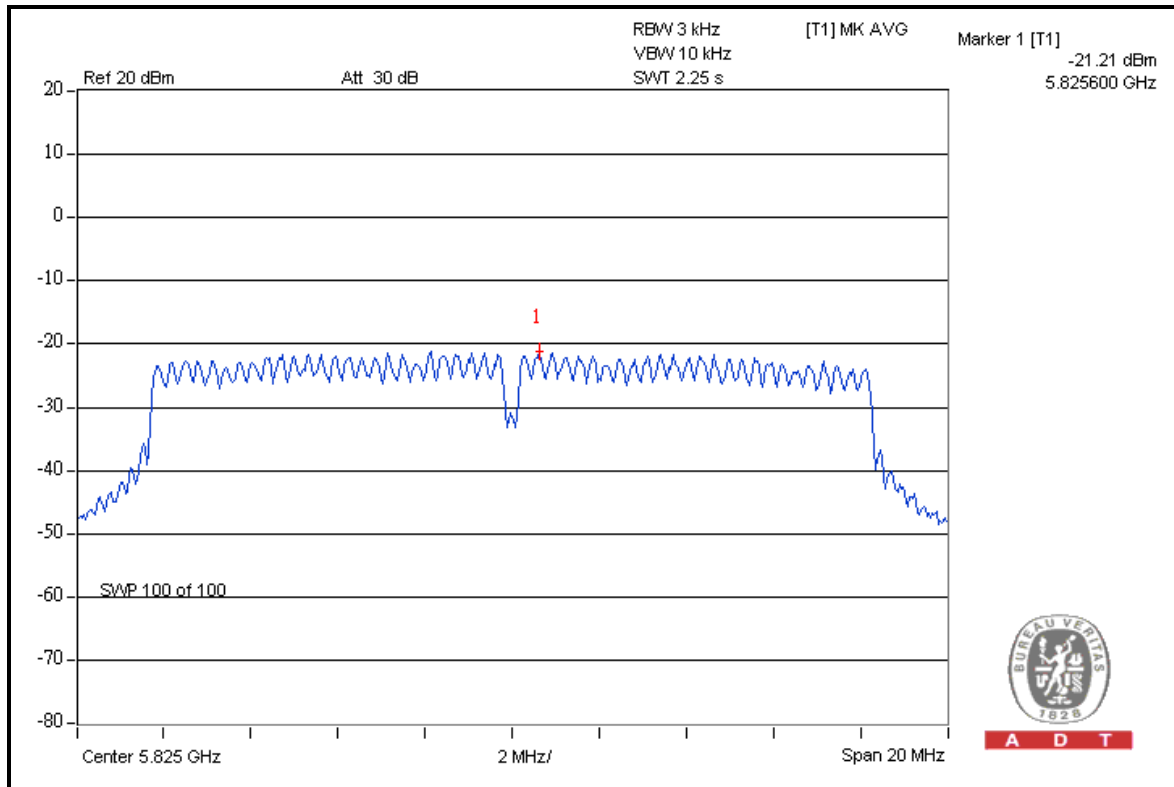

FOR CHAIN 1: CH 149

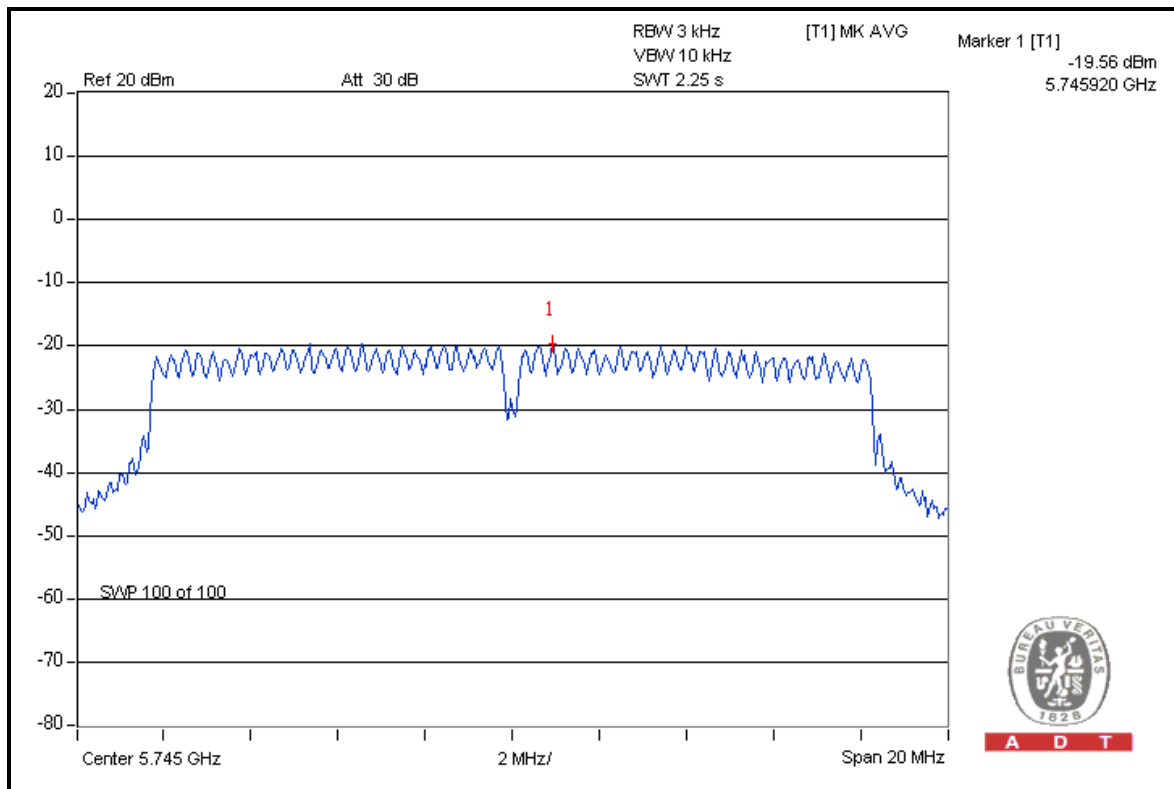



A D T

CH 157

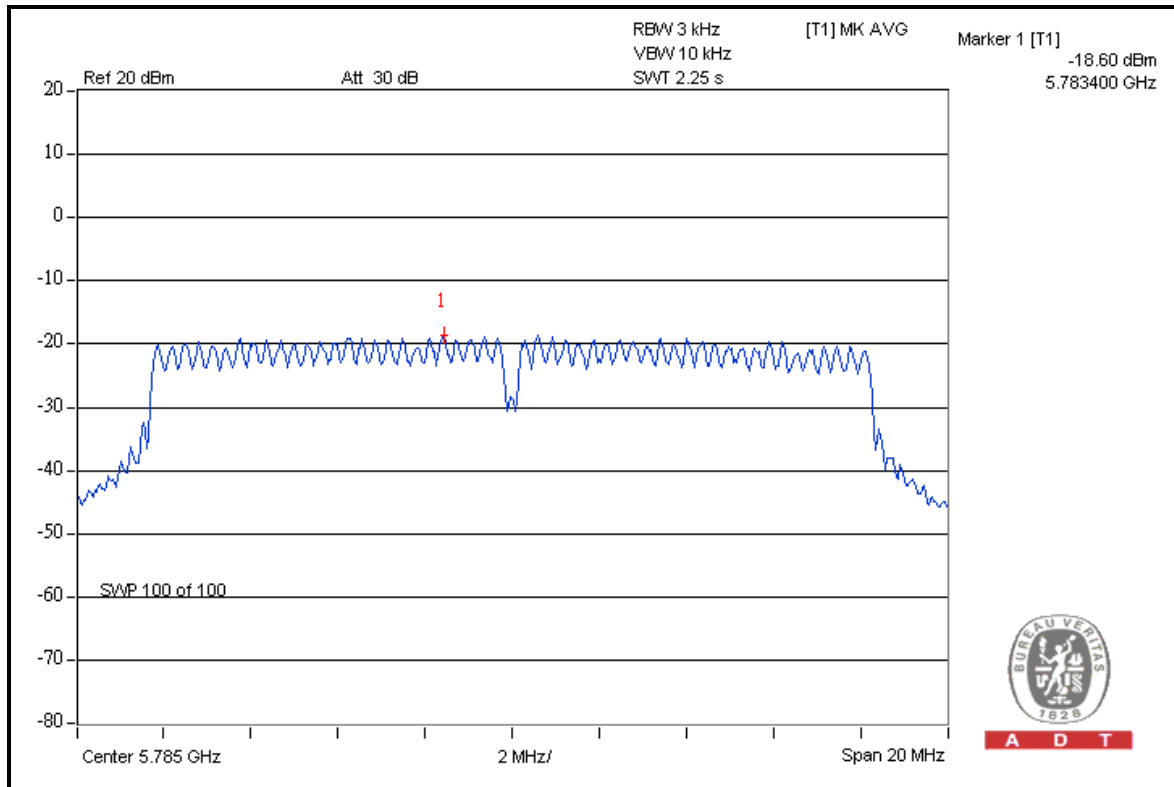

CH 165

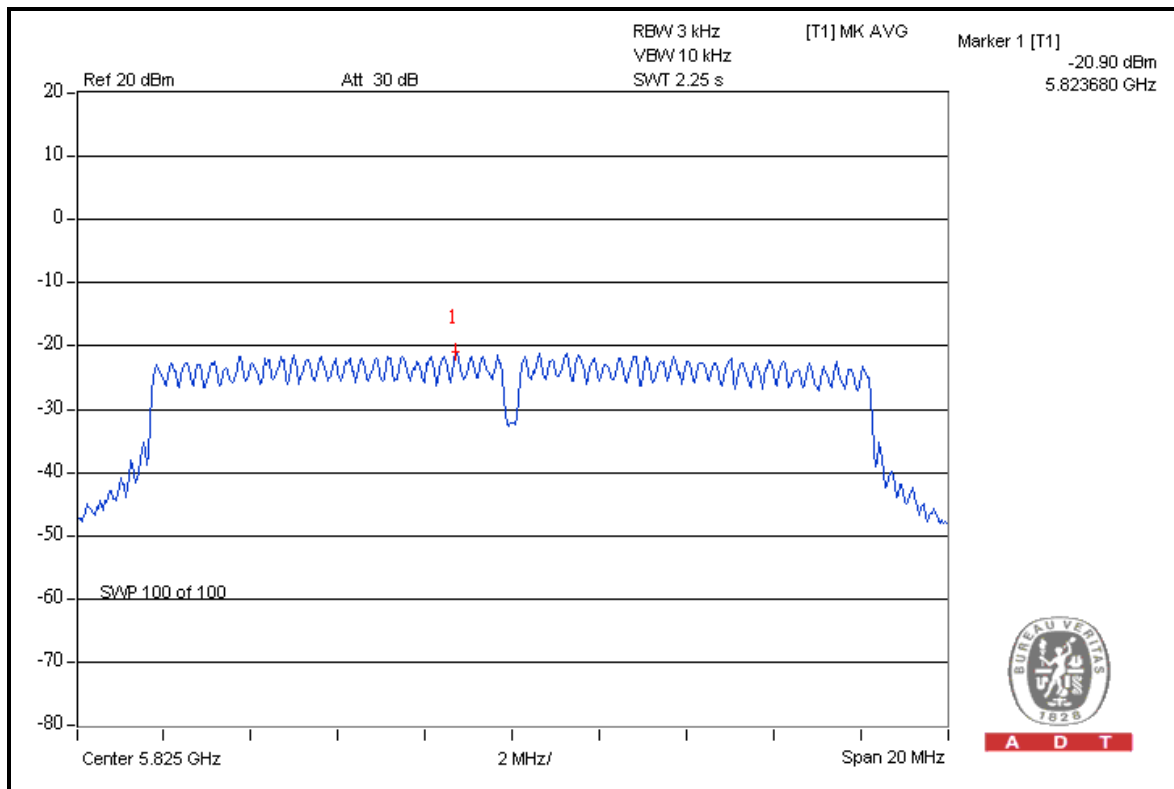



A D T

DRAFT 802.11n (40MHz) OFDM MODULATION

MODULATION TYPE	BPSK	TRANSFER RATE	13.5Mbps
INPUT POWER	120Vac, 60Hz	ENVIRONMENTAL CONDITIONS	25deg.C, 65% RH, 1010hPa
TESTED BY	Chad Lee	TEST MODE	A

CHAN.	CHAN. FREQ. (MHz)	RF POWER LEVEL IN 3kHz BW (dBm)		TOTAL POWER DENSITY (mW)	TOTAL POWER DENSITY (dBm)	MAX. LIMIT (dBm)	PASS / FAIL
		CHAIN 0	CHAIN 1				
151	5755	-16.77	-17.09	0.041	-13.92	0	PASS
159	5795	-17.26	-16.62	0.041	-13.92	0	PASS



A D T

FOR CHAIN 0: CH 151

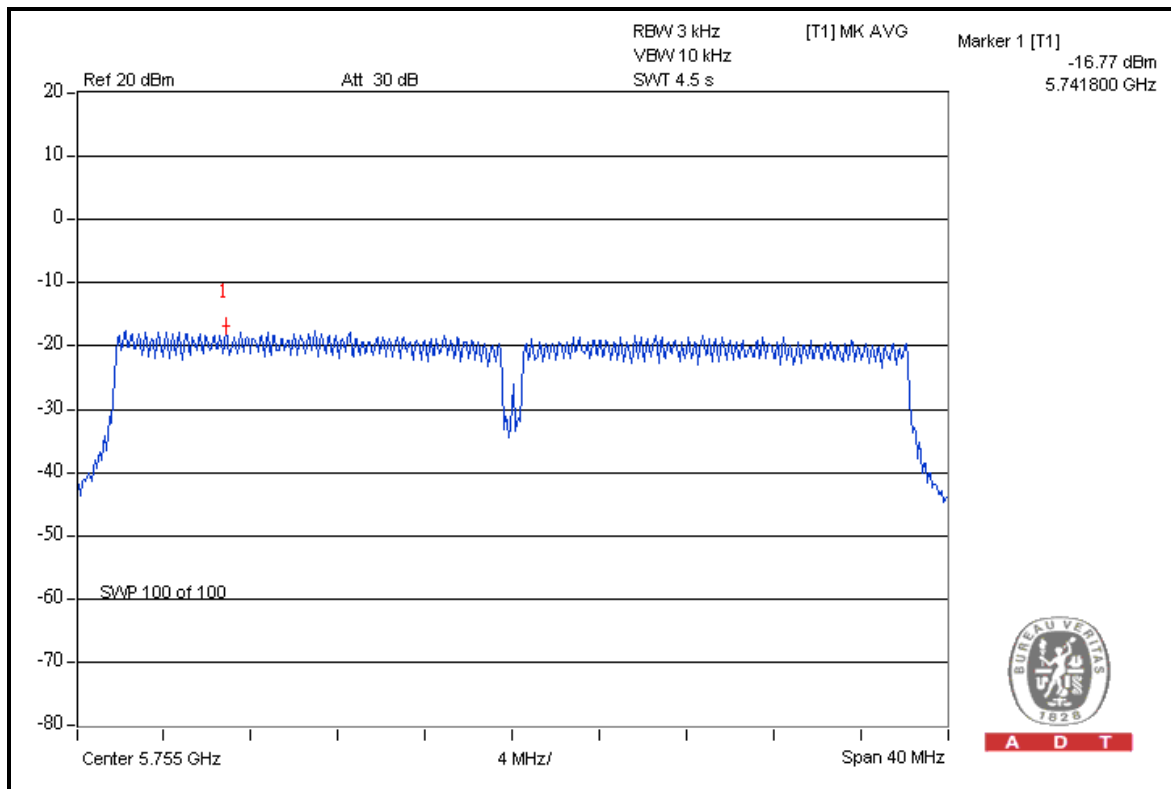

A D T

CH 159

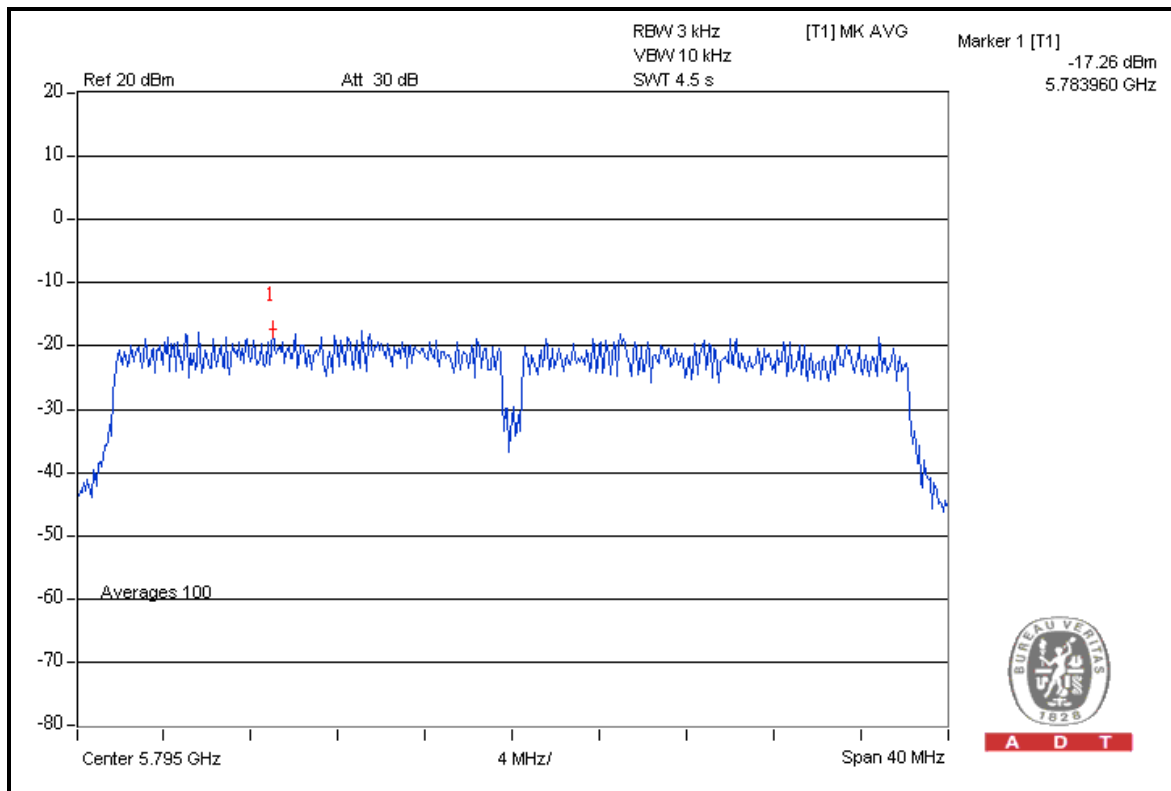

A D T



A D T

FOR CHAIN 1: CH 151

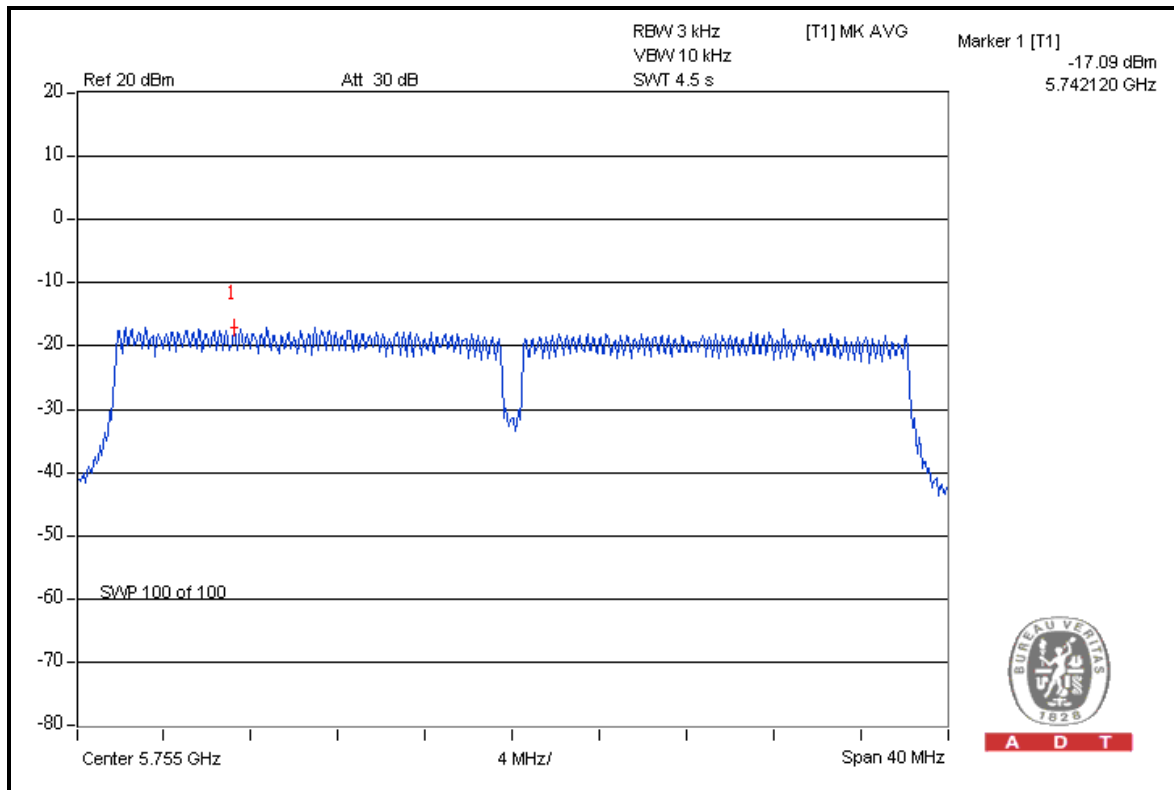

CH 159

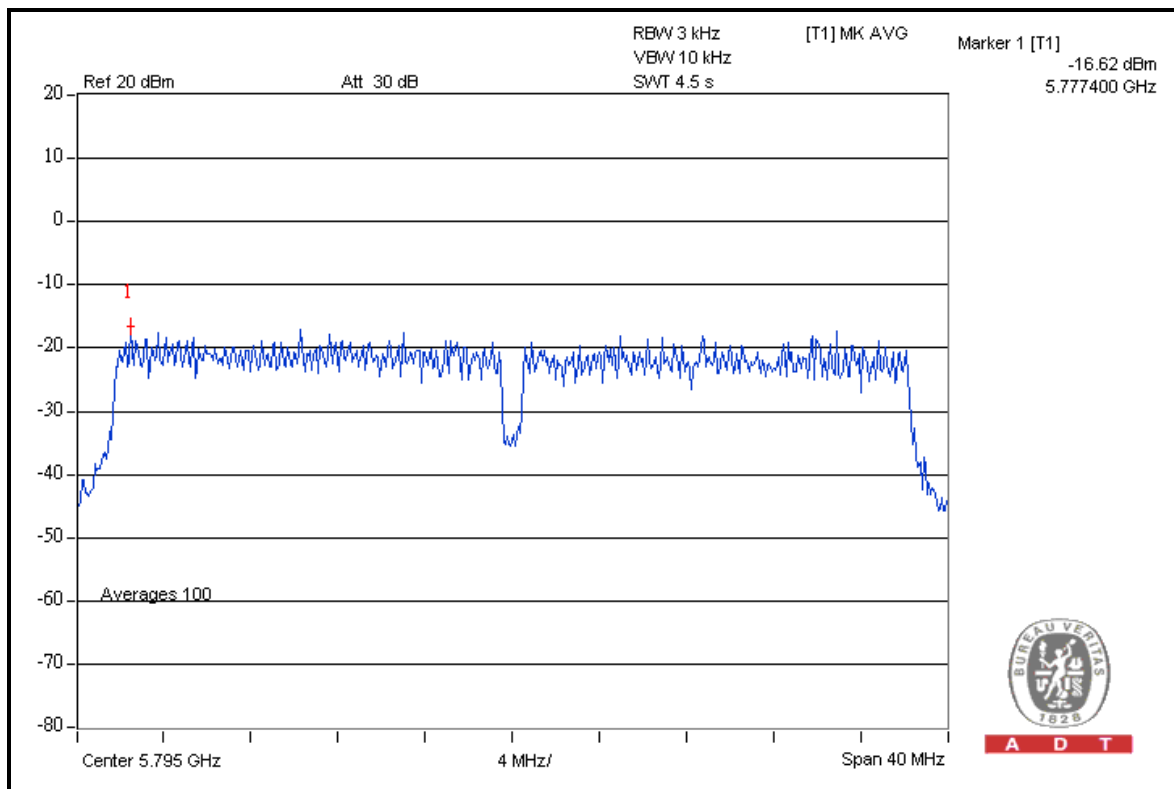



A D T

MODULATION TYPE	BPSK	TRANSFER RATE	13.5Mbps
INPUT POWER	120Vac, 60Hz	ENVIRONMENTAL CONDITIONS	25deg.C, 65% RH, 1010hPa
TESTED BY	Chad Lee	TEST MODE	C

CHAN.	CHAN. FREQ. (MHz)	RF POWER LEVEL IN 3kHz BW (dBm)		TOTAL POWER DENSITY (mW)	TOTAL POWER DENSITY (dBm)	MAX. LIMIT (dBm)	PASS / FAIL
		CHAIN 0	CHAIN 1				
151	5755	-18.75	-23.03	0.018	-17.37	-9	PASS
159	5795	-24.10	-24.51	0.007	-21.29	-9	PASS



A D T

FOR CHAIN 0: CH 151

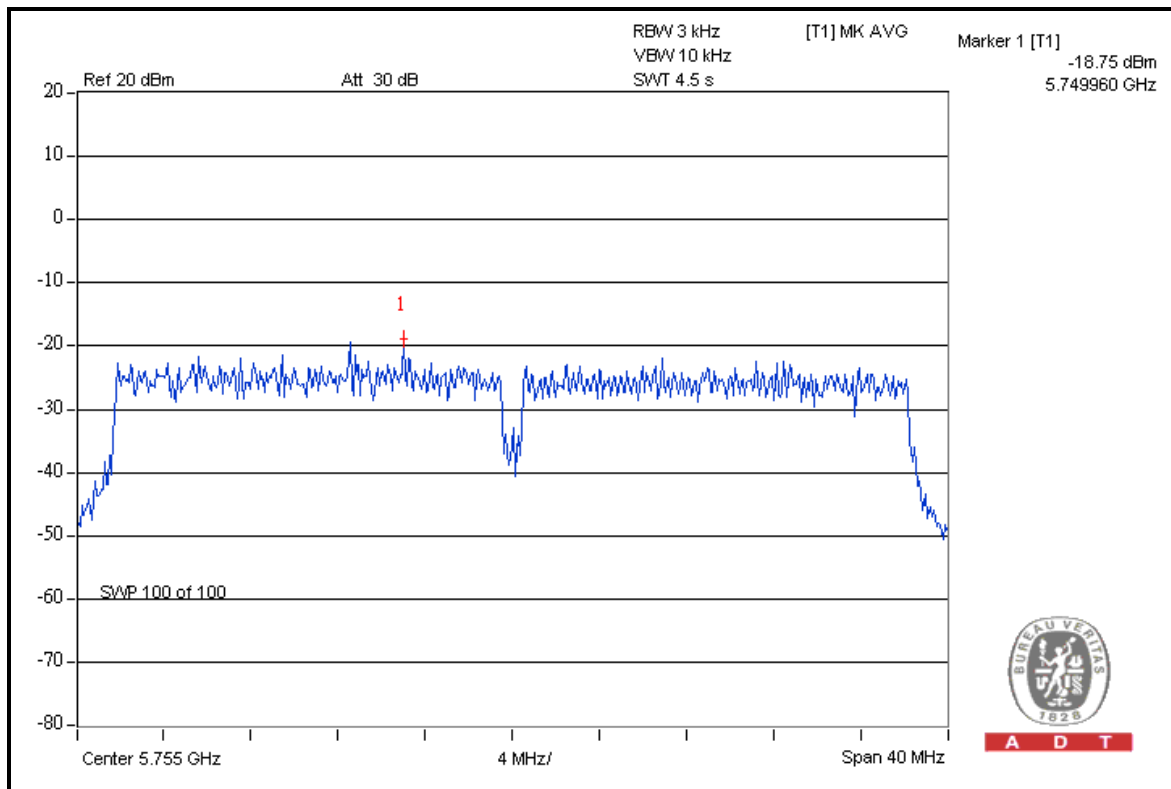

A D T

CH 159

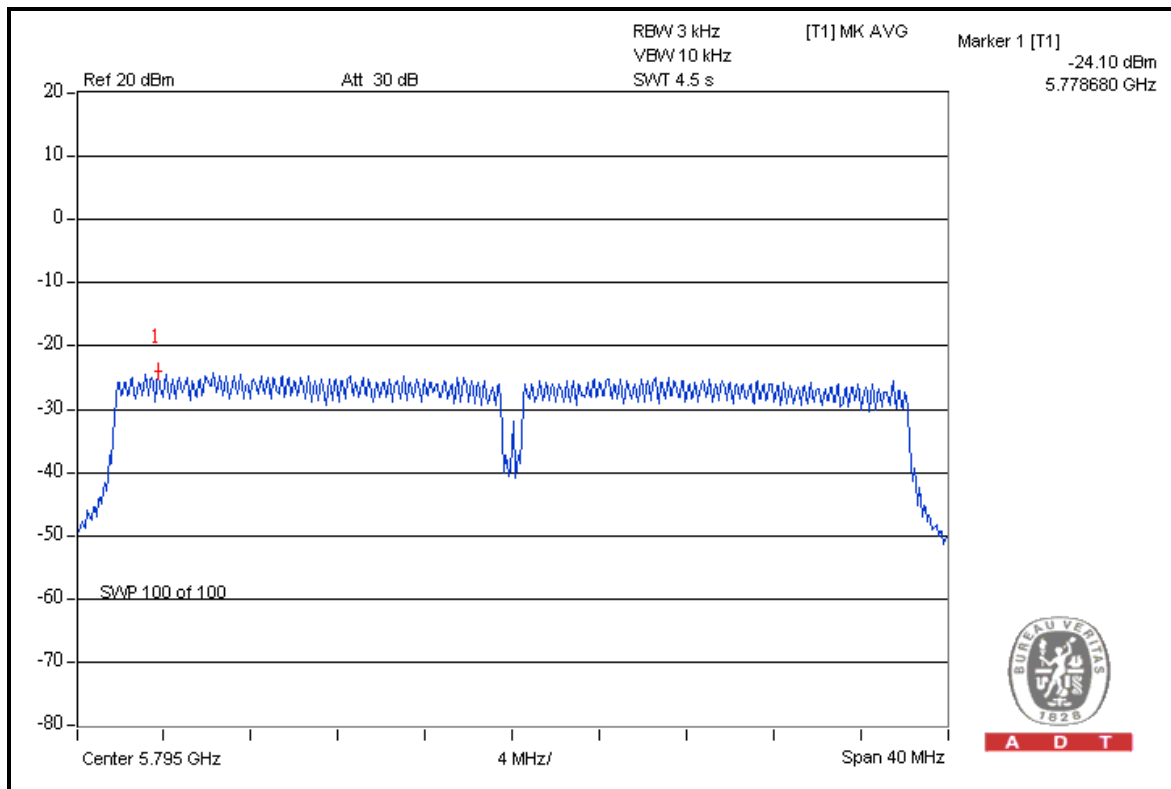

A D T



A D T

FOR CHAIN 1: CH 151

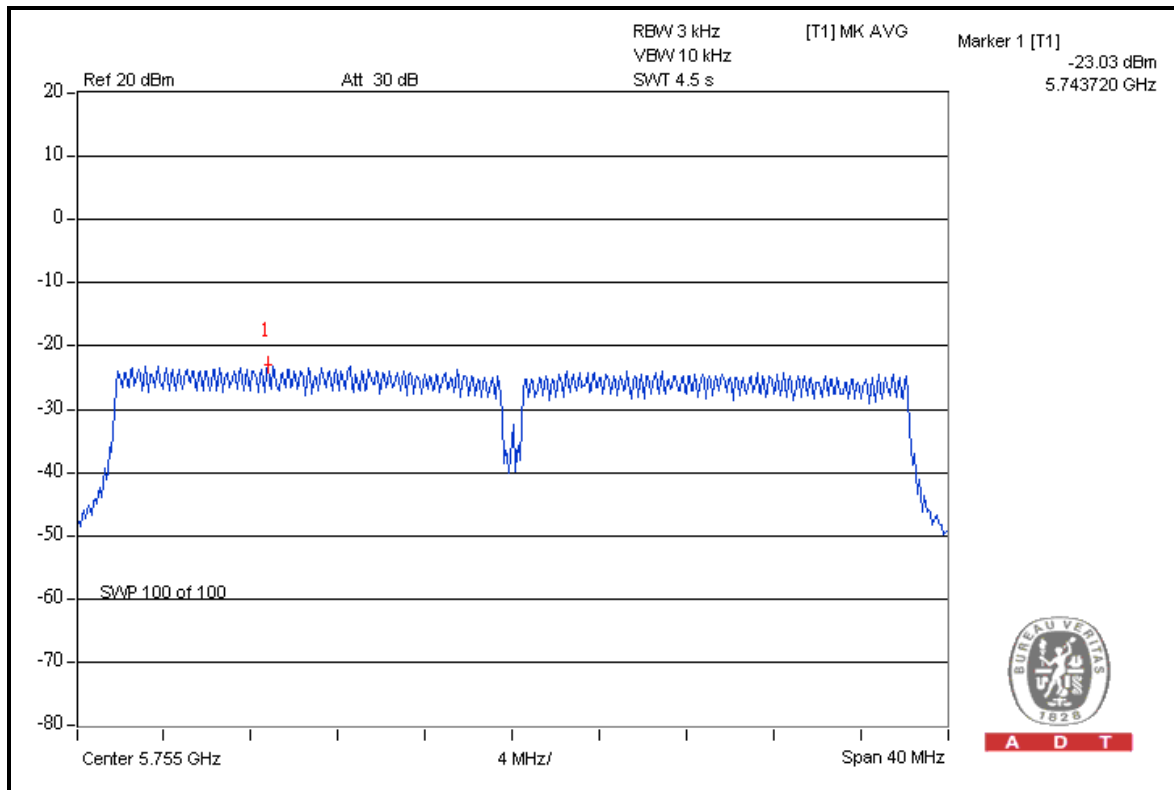

CH 159

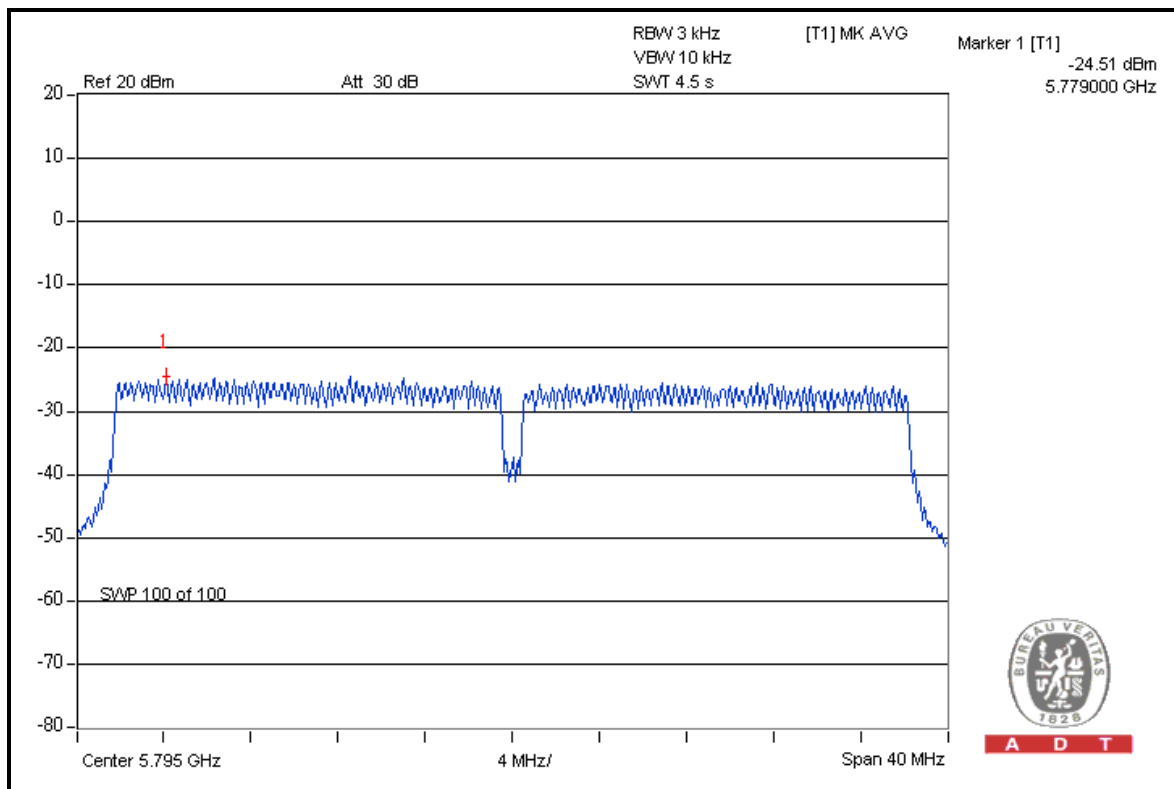



A D T

4.6 BAND EDGES MEASUREMENT

4.6.1 LIMITS OF BAND EDGES MEASUREMENT

Below –30dB of the highest emission level of operating band (in 100kHz Resolution Bandwidth).

Note: Follow DTS measurement, if the device complies with the use of power option 2 the attenuation under this paragraph shall be 30 dB instead of 20 dB.

4.6.2 TEST INSTRUMENTS

DESCRIPTION & MANUFACTURER	MODEL NO.	SERIAL NO.	CALIBRATED DATE	CALIBRATED UNTIL
Agilent Spectrum	8564EC	4208A00659	Jul. 24, 2009	Jul. 23, 2010
Agilent Preamplifier	8449B	3008A01924	Aug. 31, 2009	Aug. 30, 2010
Agilent Preamplifier	8449B	3008A01292	Aug. 10, 2009	Aug. 09, 2010
MITEQ Preamplifier	AMF-6F-2604 00-33-8P	892164	Aug. 31, 2009	Aug. 30, 2010
Schwarzbeck Horn Antenna	BBHA-9170	BBHA9170190	Sep. 24, 2009	Sep. 23, 2010
Schwarzbeck Horn Antenna	BBHA-9120	D130	May 15, 2009	May 14, 2010
ADT. Turn Table	TT100	0201	NA	NA
ADT. Tower	AT100	0201	NA	NA
Software	ADT_Radiate d_V7.6.15.9.2	NA	NA	NA
SUHNER RF cable	SF106-18	PHACAB-1G-40 GHz	Aug. 20, 2009	Aug. 19, 2010

- NOTE:**
1. The calibration interval of the above test instruments is 12 months. And the calibrations are traceable to NML/ROC and NIST/USA.
 2. The test was performed in Open Site No. 10.
 3. The Industry Canada Reference No. IC 7450E-10.
 4. The FCC Site Registration No. 698148.



A D T

4.6.3 TEST PROCEDURE

- a. The EUT was placed on the top of a rotating table 0.8 meters above the ground at a 10-meter open area test site. The table was rotated 360 degrees to determine the position of the highest radiation.
- b. The EUT was set 3 meters away from the interference-receiving antenna, which was mounted on the top of a variable-height antenna tower.
- c. The antenna is a broadband antenna, and its height is varied from one meter to four meters above the ground to determine the maximum value of the field strength. Both horizontal and vertical polarizations of the antenna are set to make the measurement.
- d. For each suspected emission, the EUT was arranged to its worst case and then the antenna was tuned to heights from 1 meter to 4 meters and the rotatable table was turned from 0 degrees to 360 degrees to find the maximum reading.
- e. Set both RBW and VBW of spectrum analyzer to 100kHz and 300kHz with suitable frequency span including 100MHz bandwidth from band edge. The band edges was measured and recorded.

NOTE: The resolution bandwidth of test receiver/spectrum analyzer is 1MHz and the video bandwidth is 10Hz for Average detection (AV) at frequency above 1GHz.



A D T

4.6.4 DEVIATION FROM TEST STANDARD

No deviation.

4.6.5 EUT OPERATING CONDITION

Same as Item 4.3.6.

4.6.6 TEST RESULTS

The spectrum plots are attached on the following pages. D1 line indicates the highest level, D2 line indicates the 30dB offset below D1. It shows compliance with the requirement in part 15.247(d).



A D T

802.11a OFDM MODULATION

For Mode A:

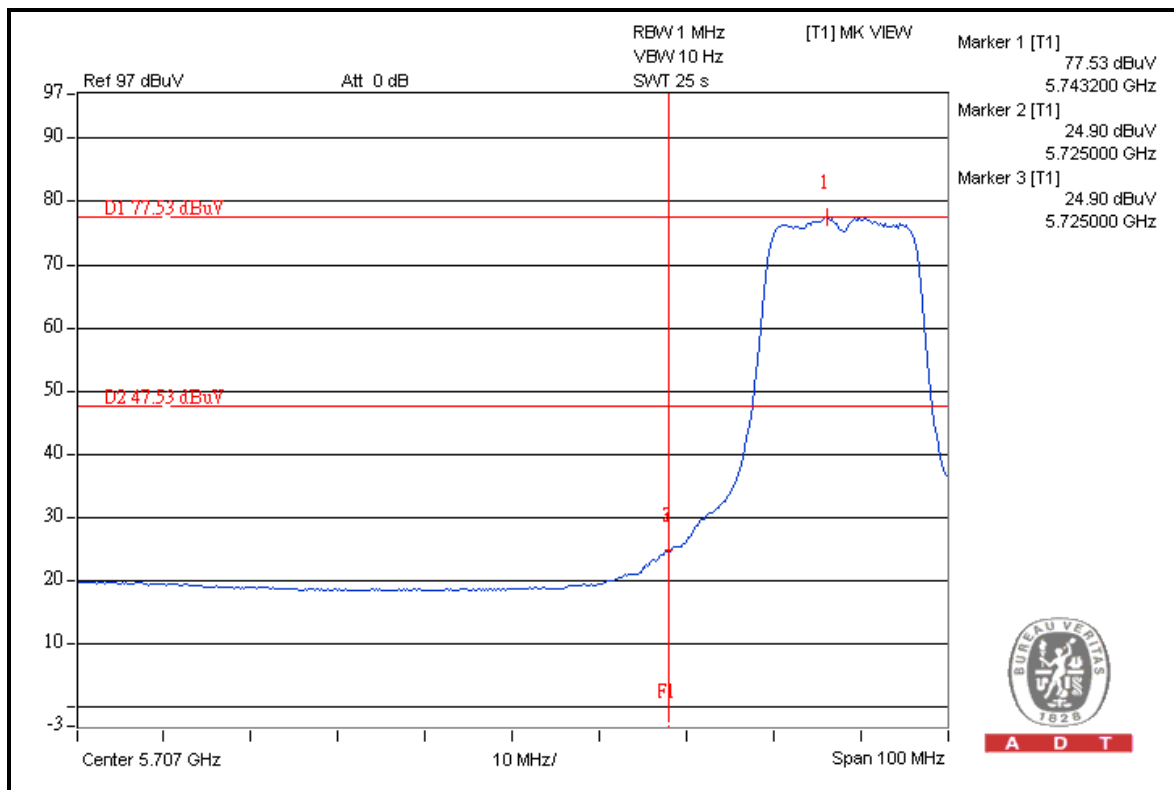
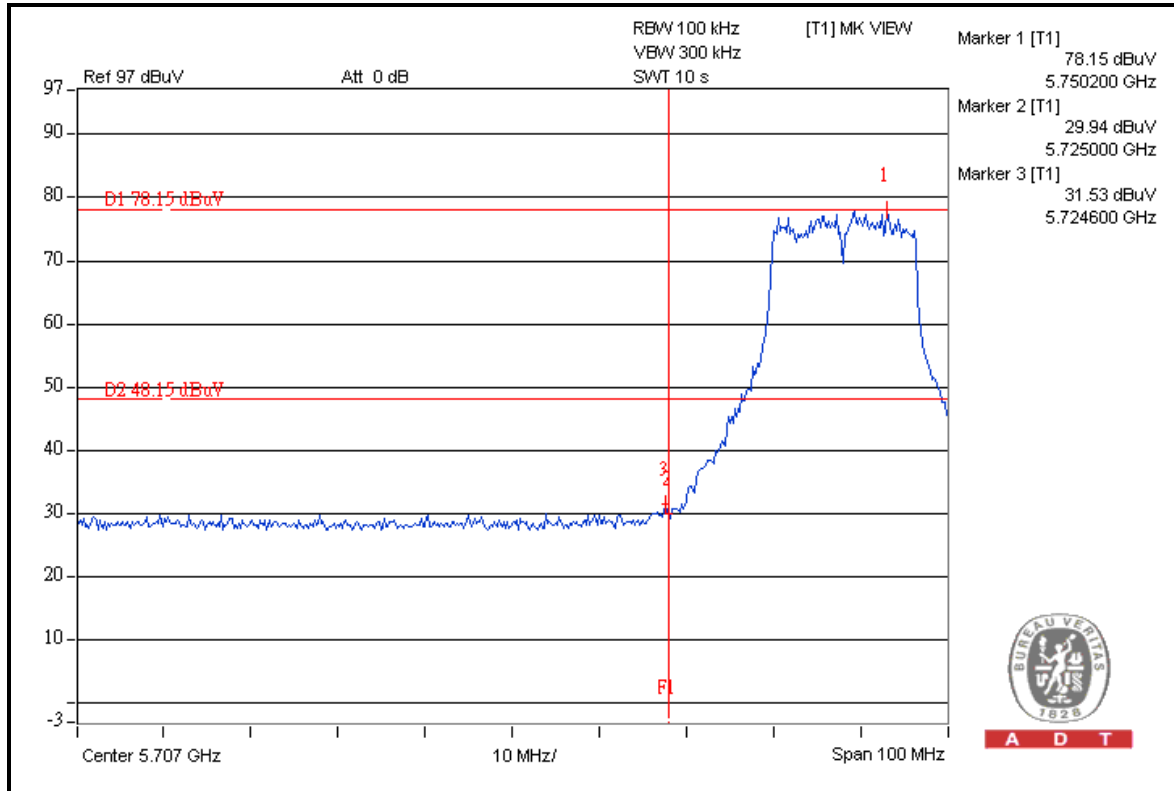



A D T

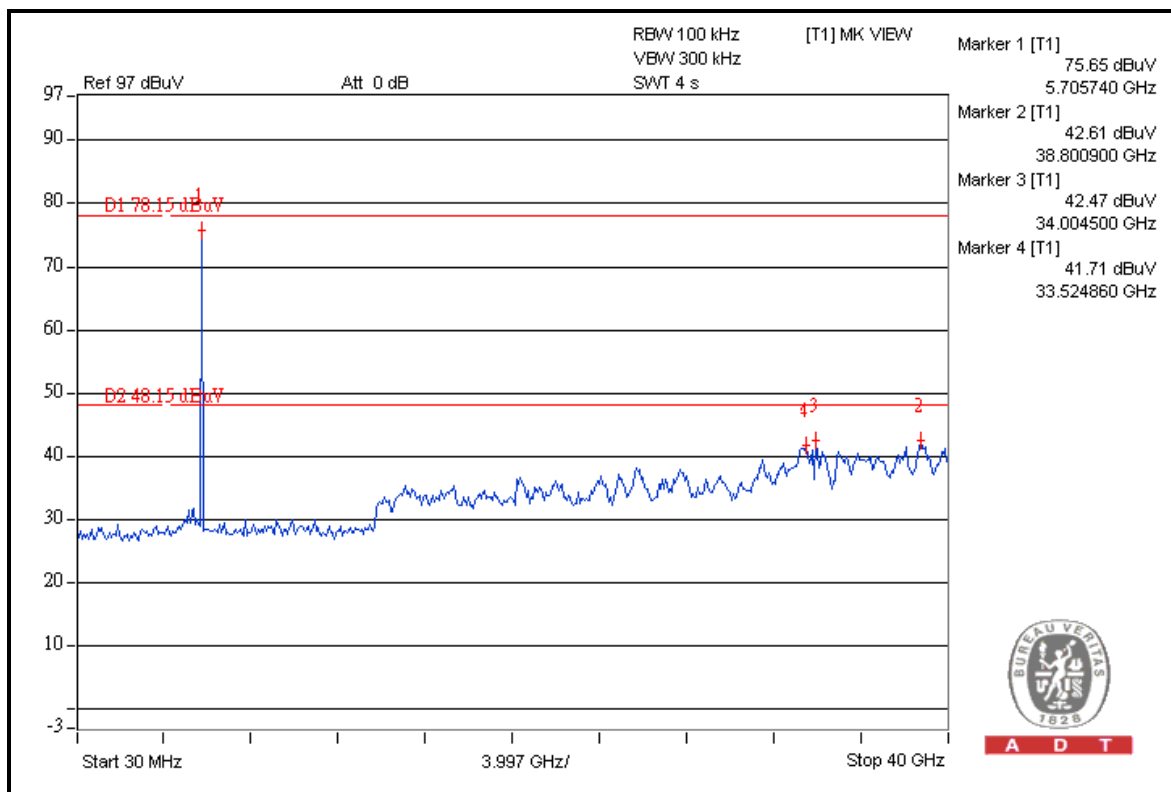

A D T

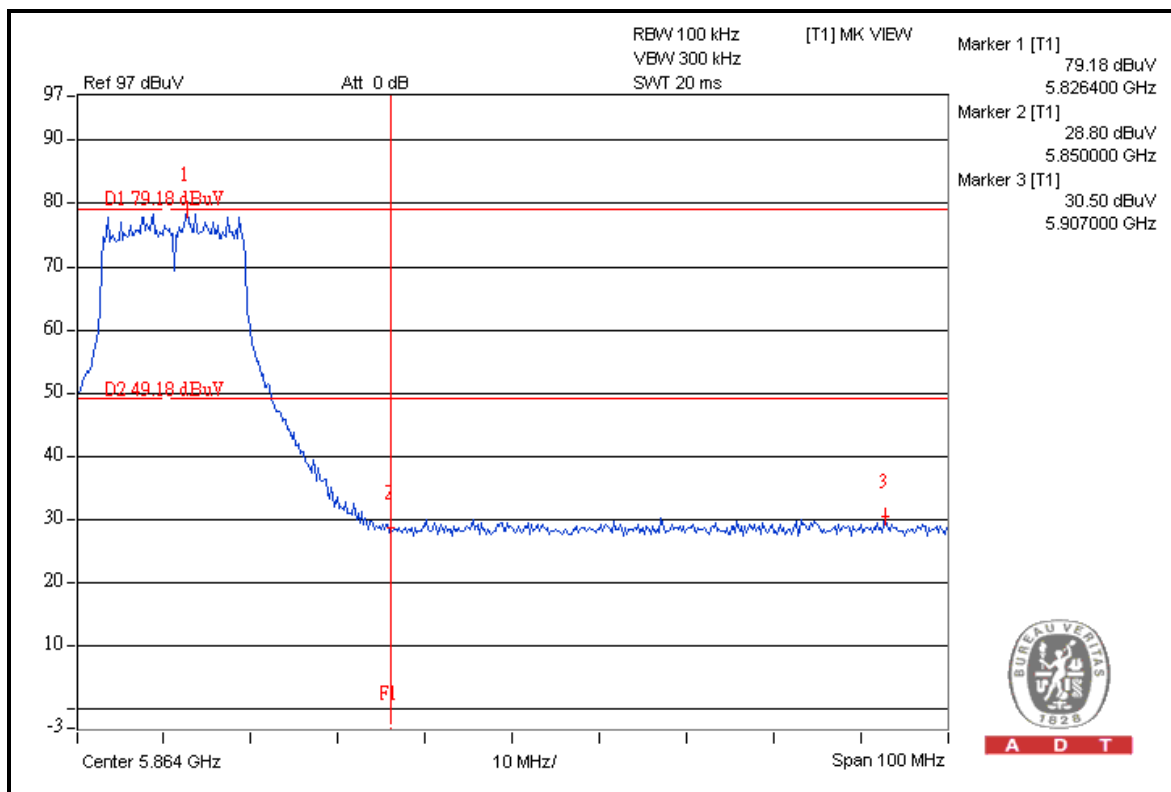

A D T



A D T

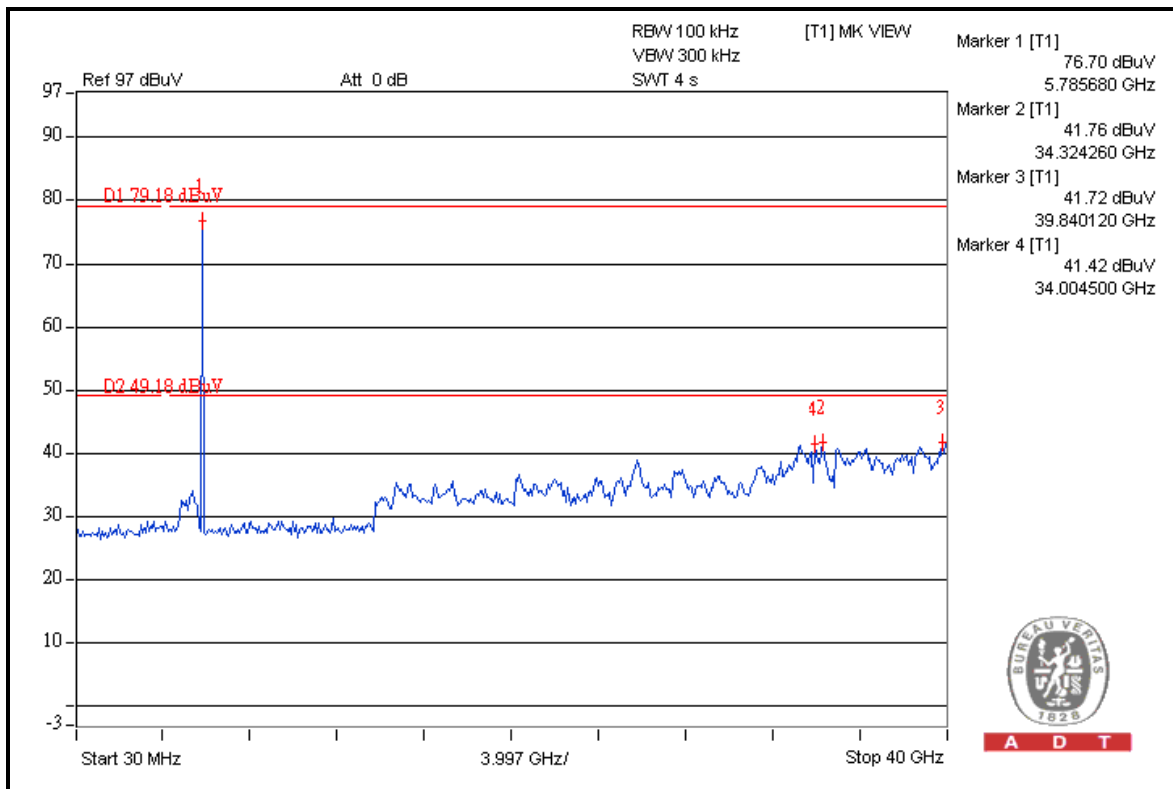
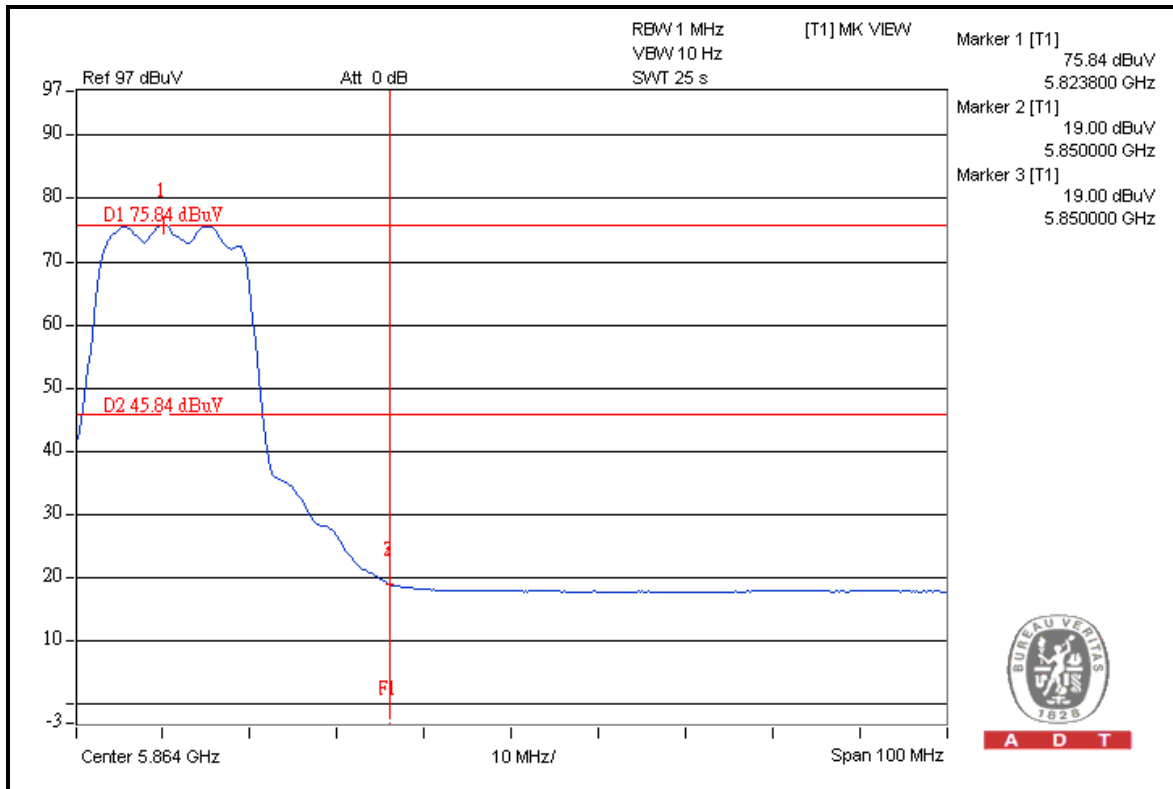



A D T

For Mode C:

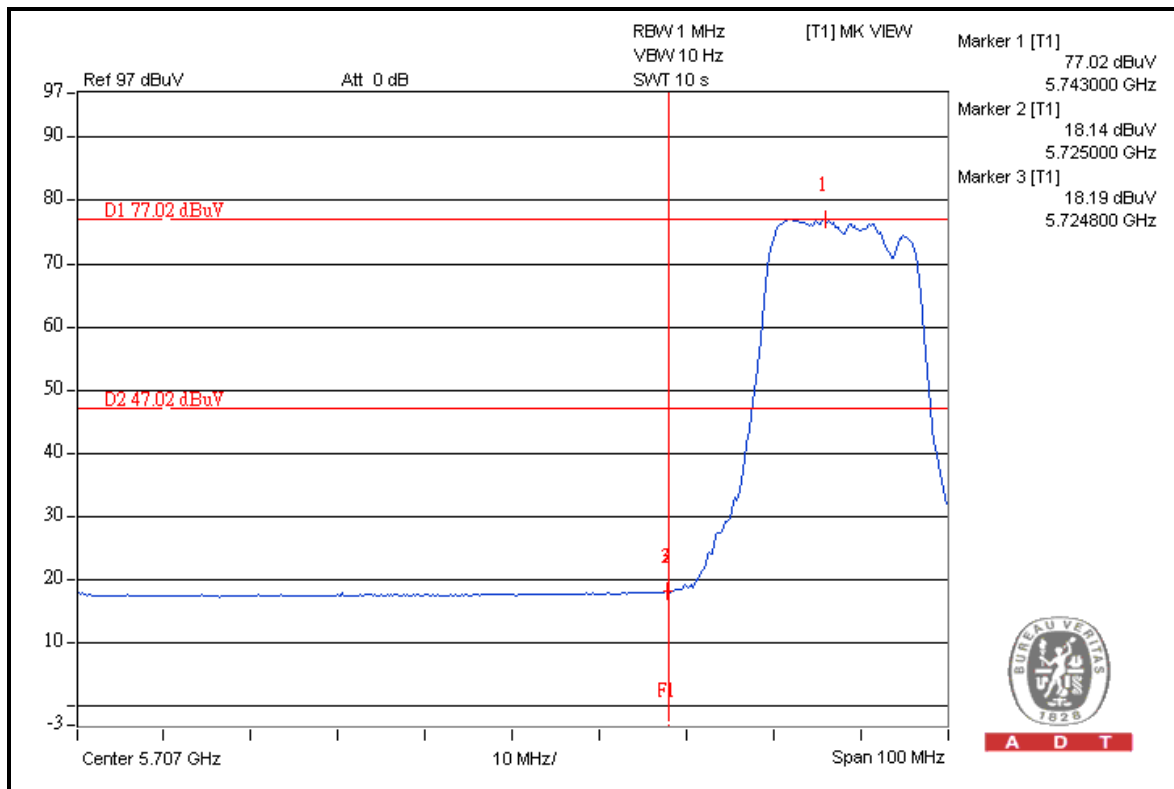
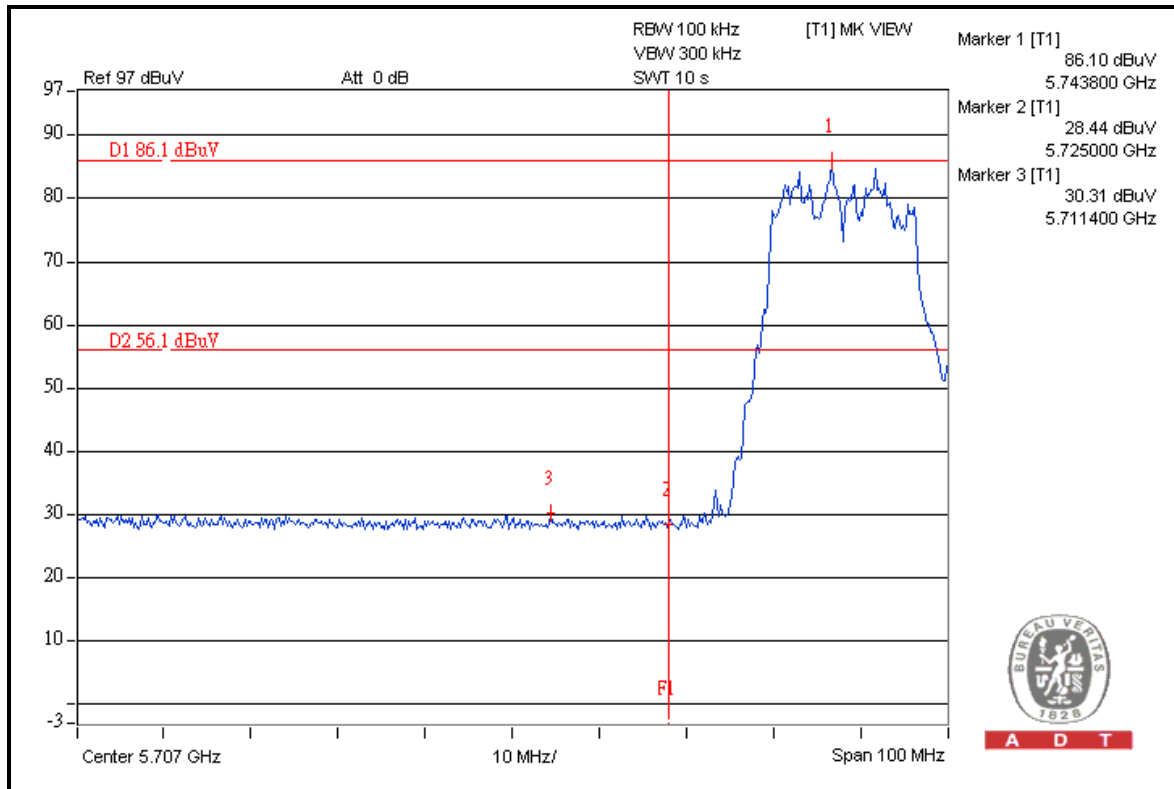



A D T

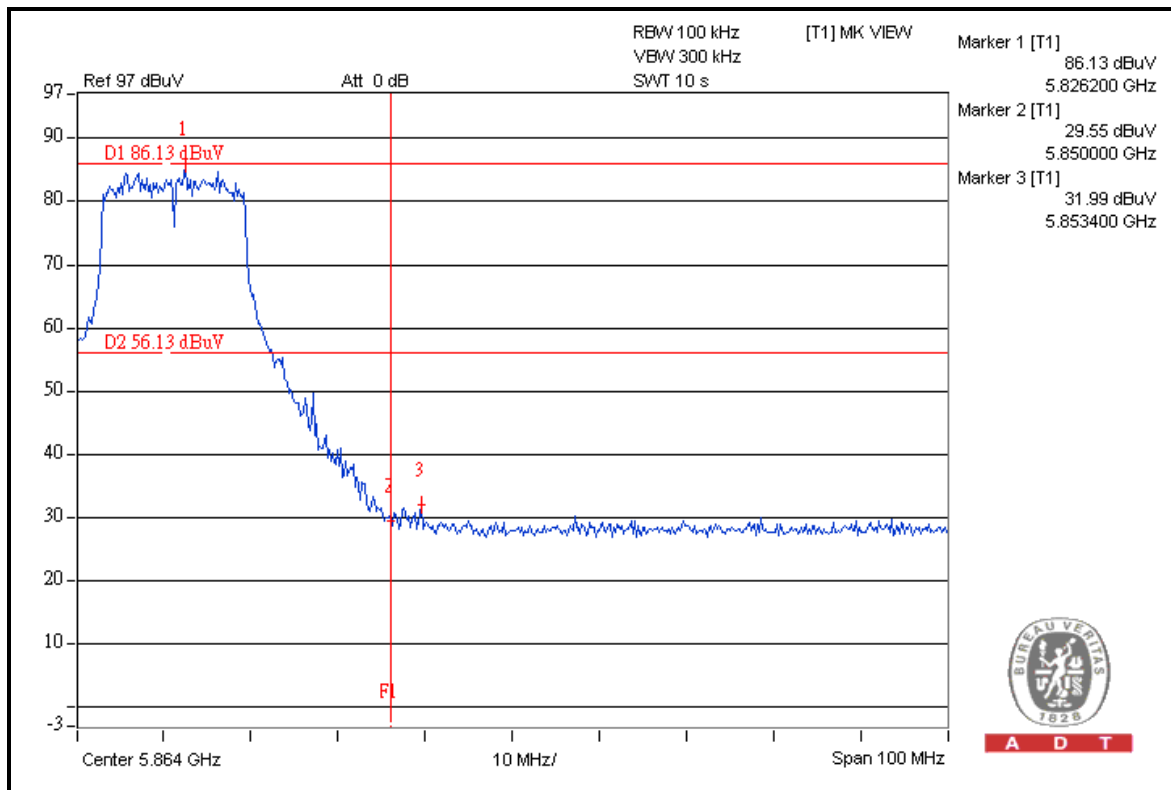
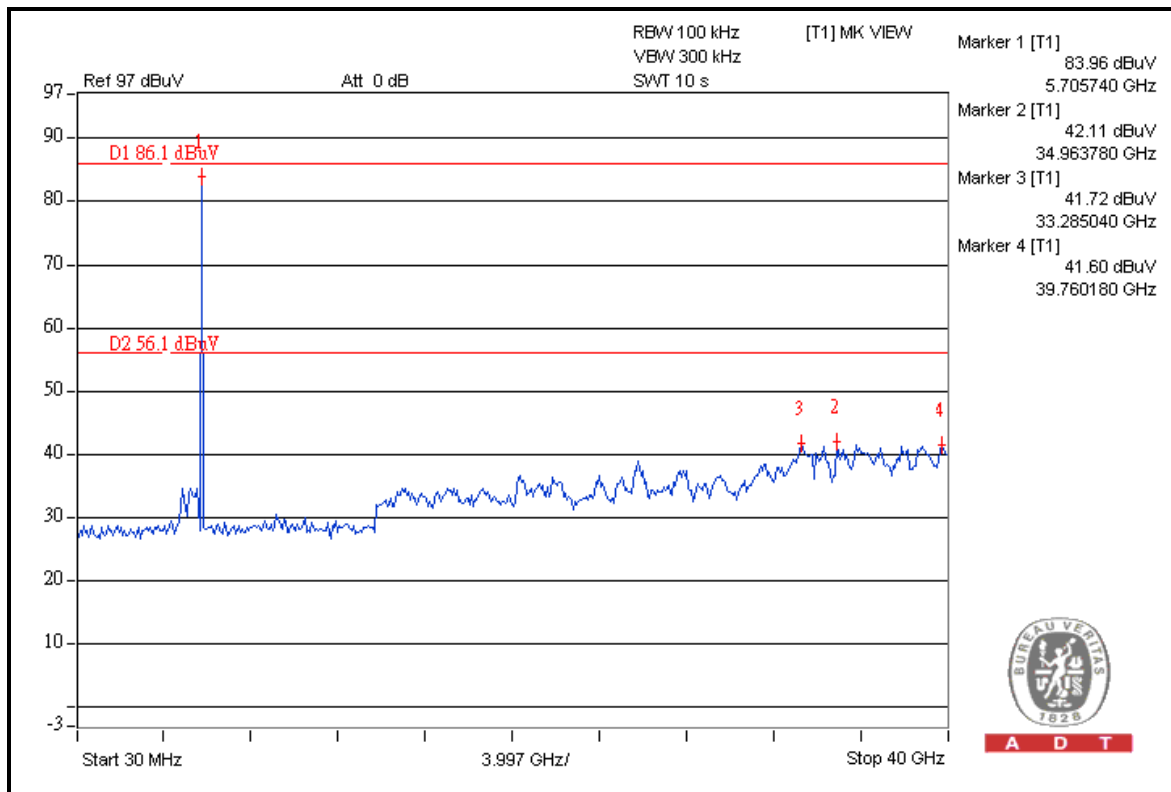



A D T

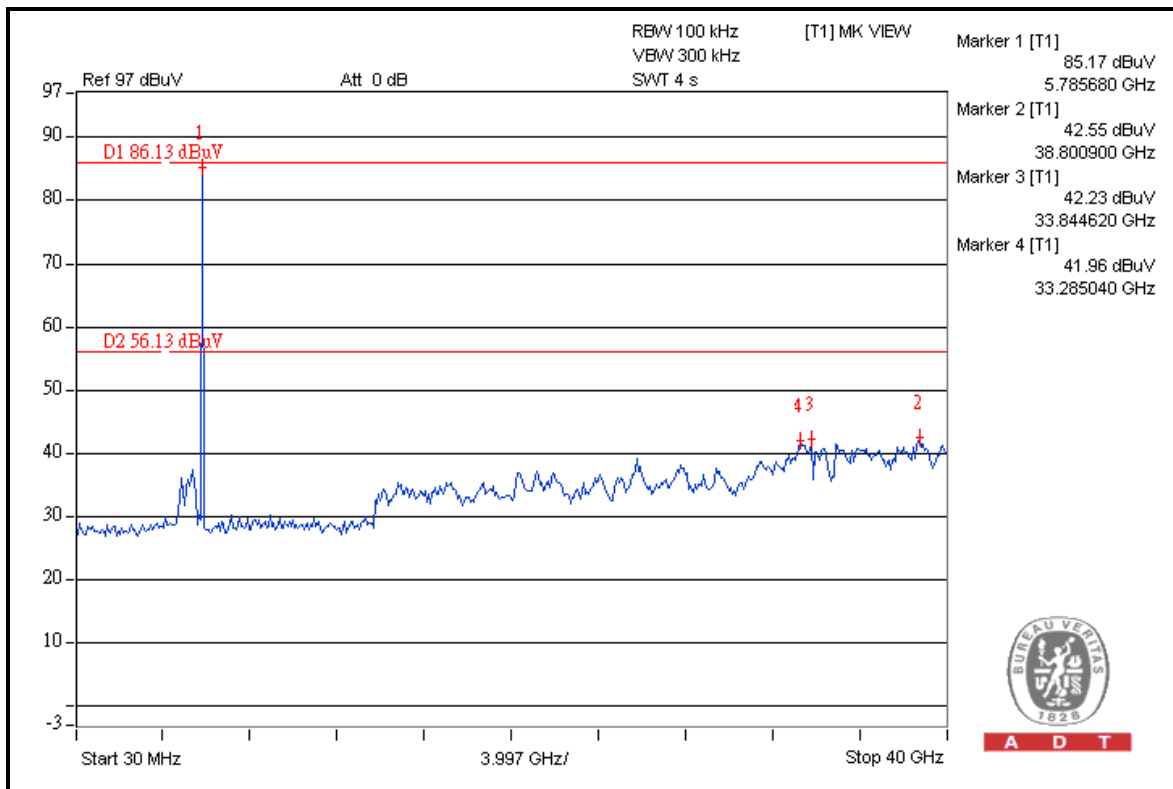
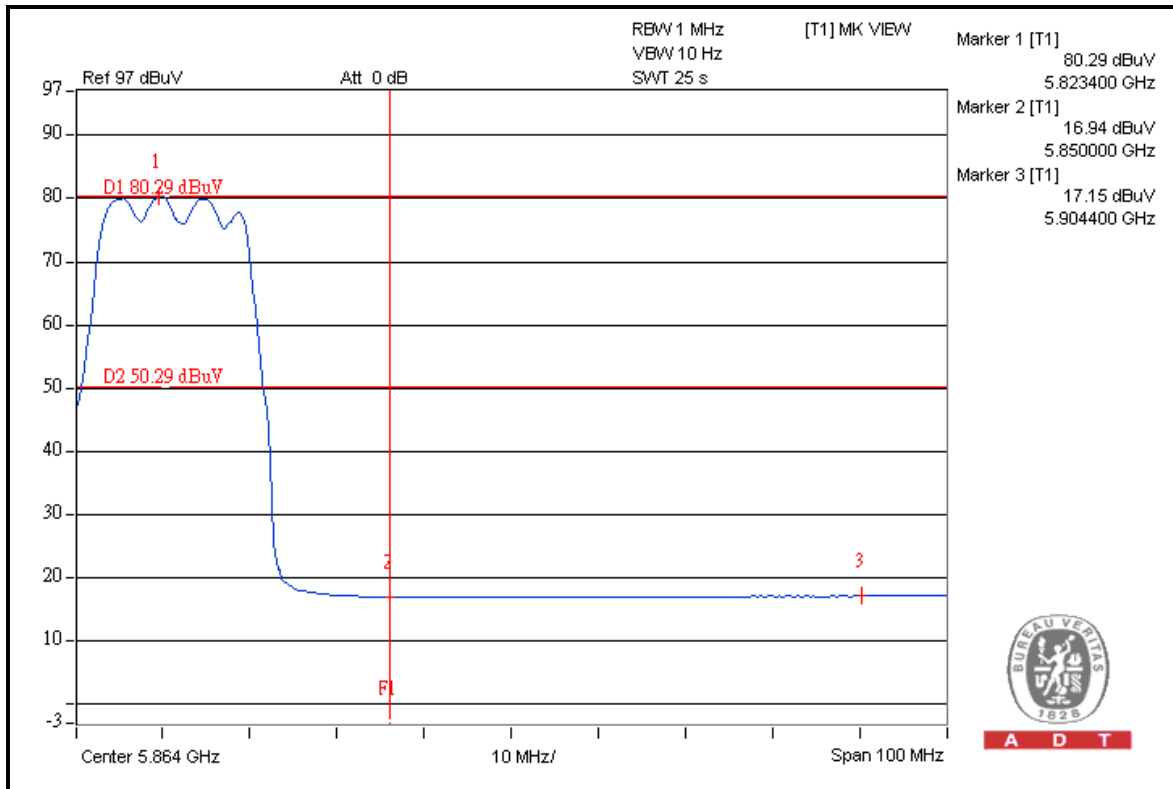



A D T

DRAFT 802.11n (20MHz) OFDM MODULATION

For Mode A:

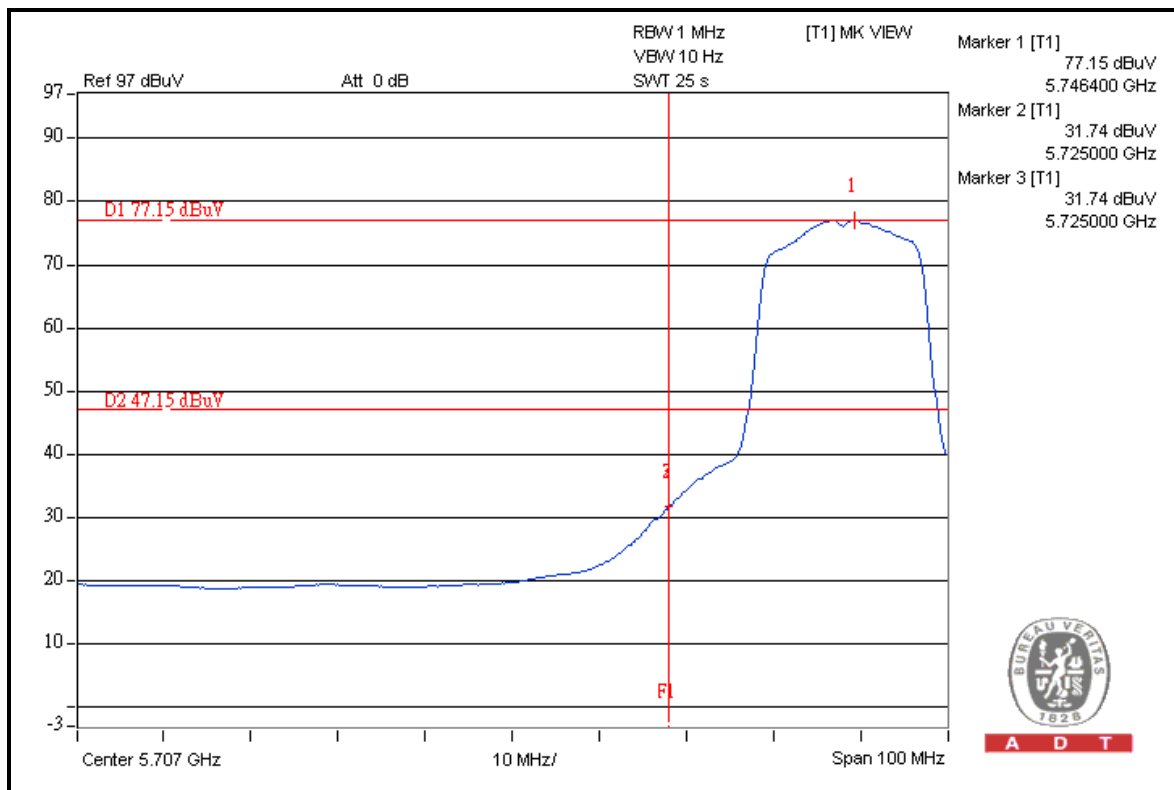
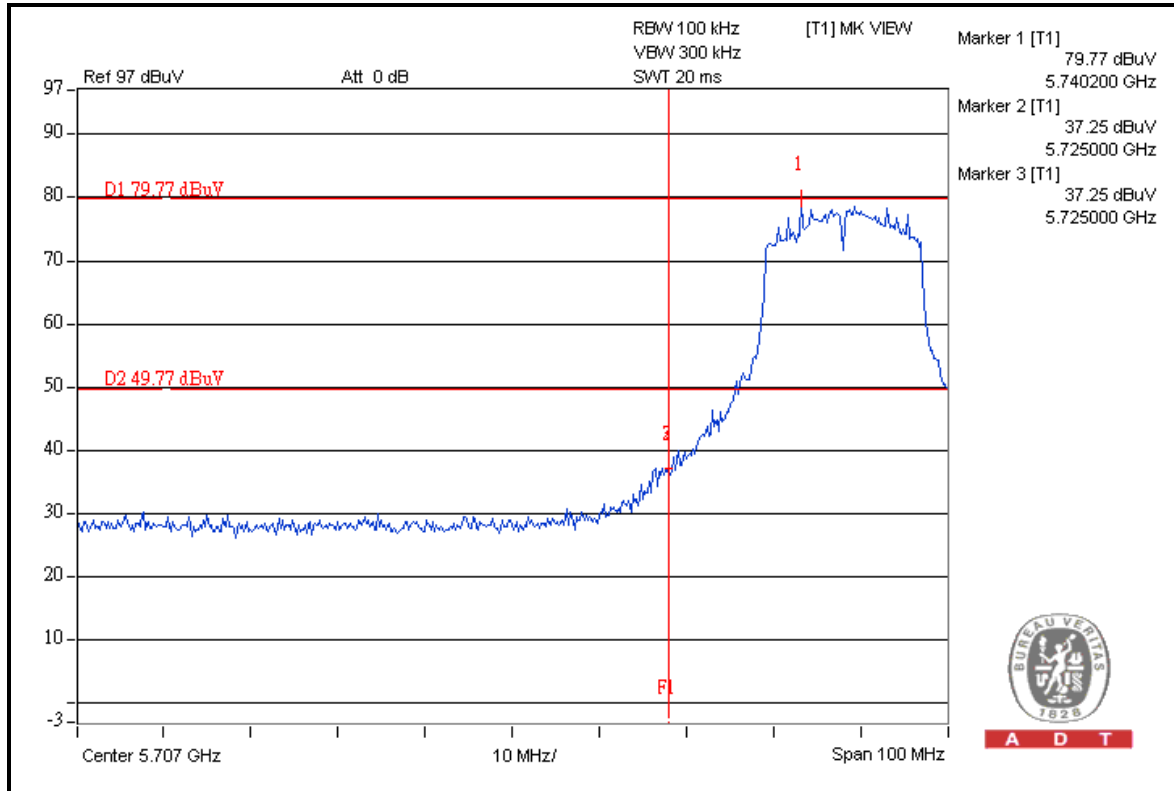



A D T

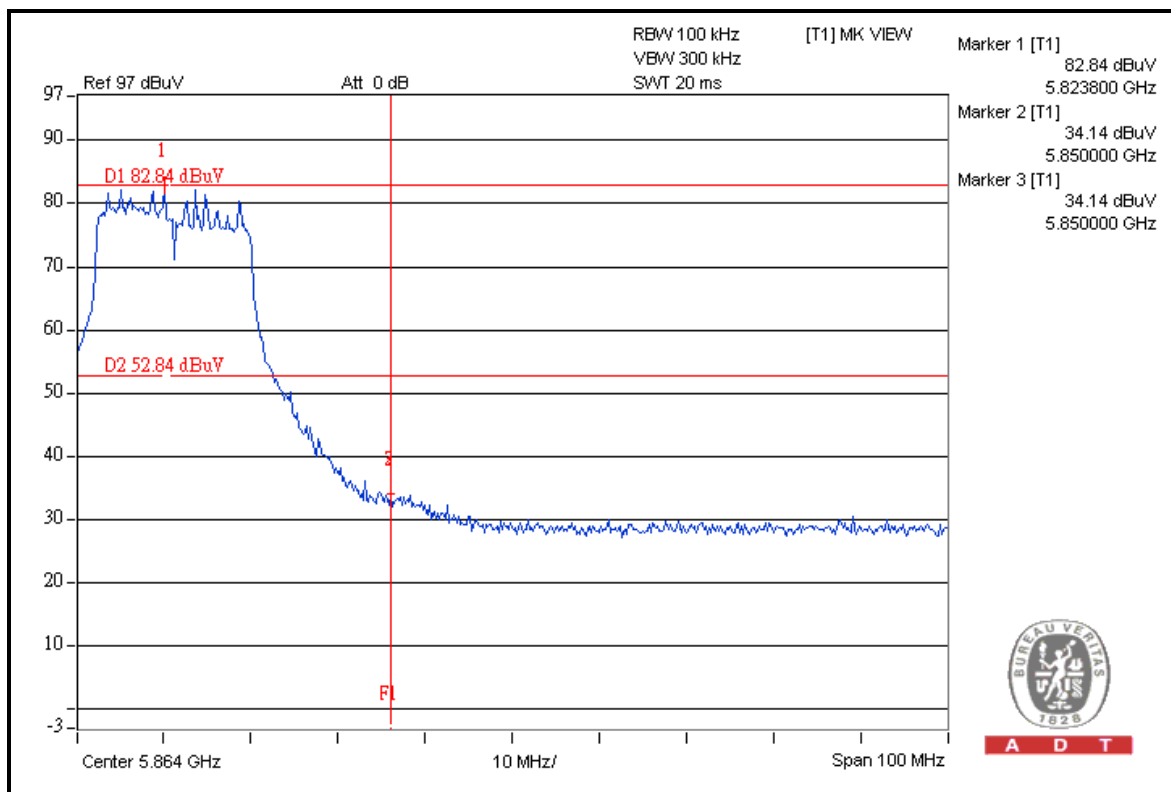
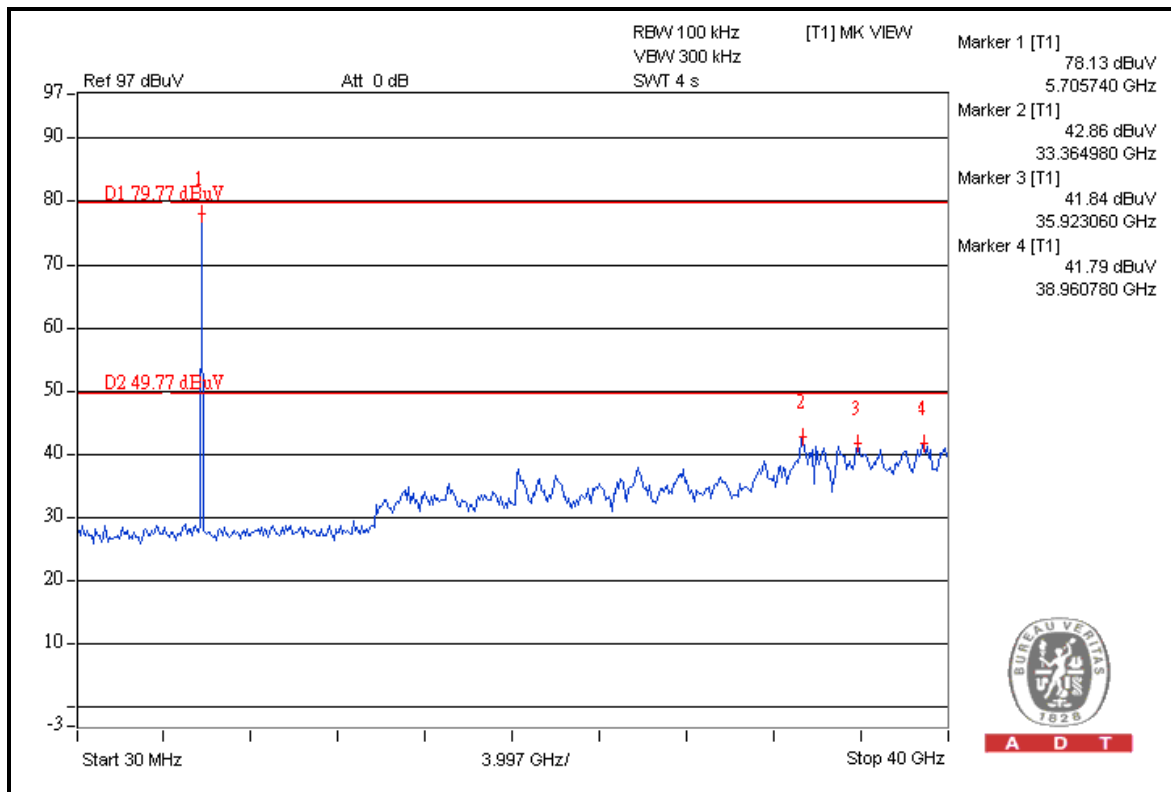



A D T

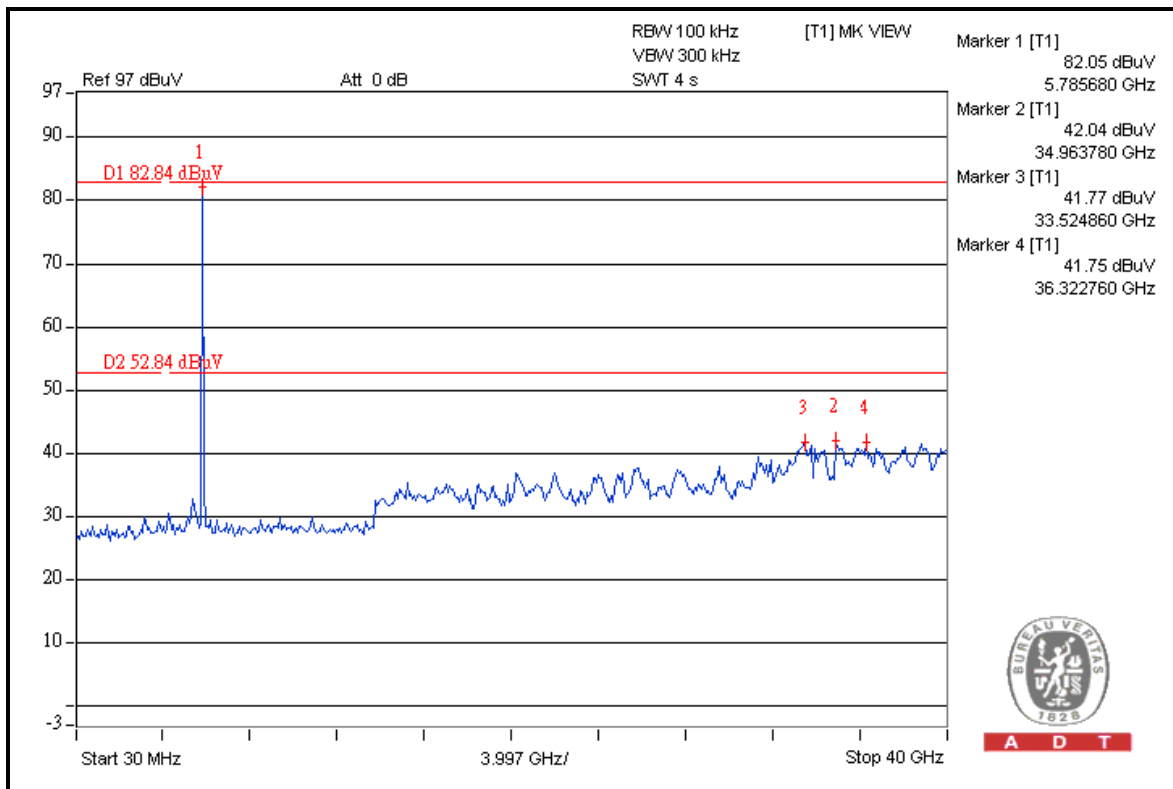
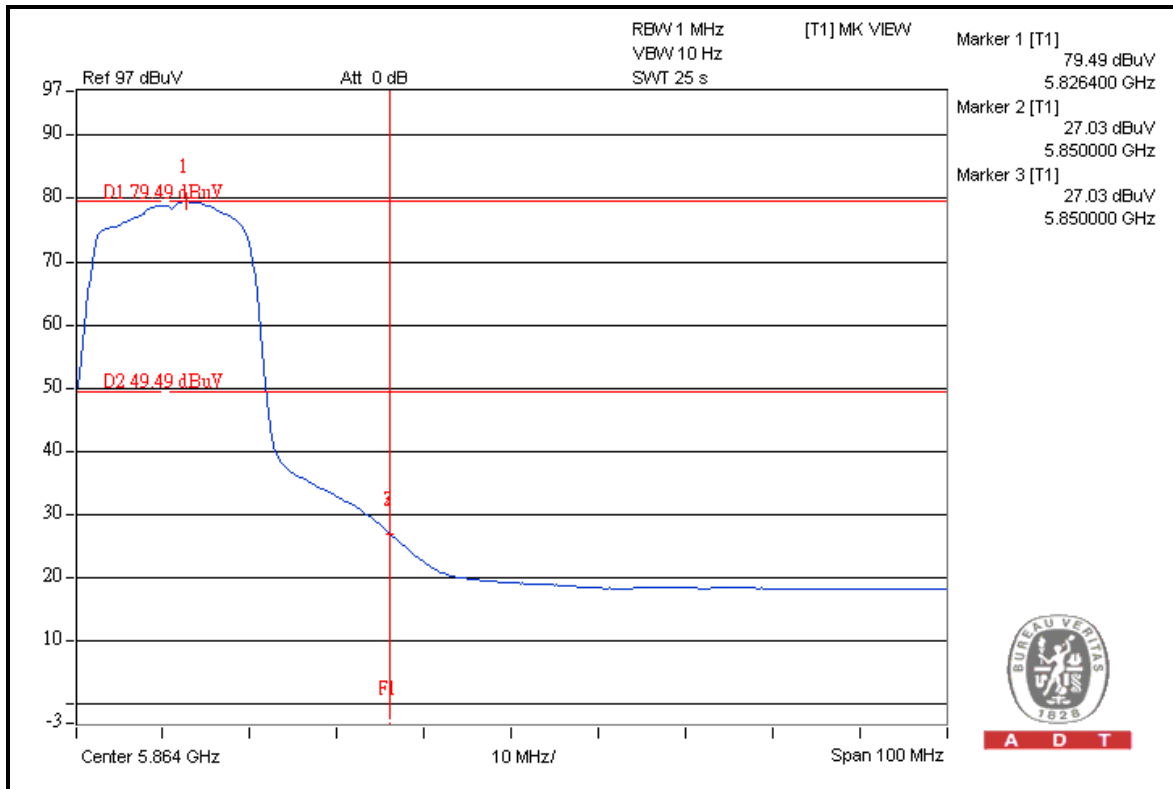



A D T

For Mode C:

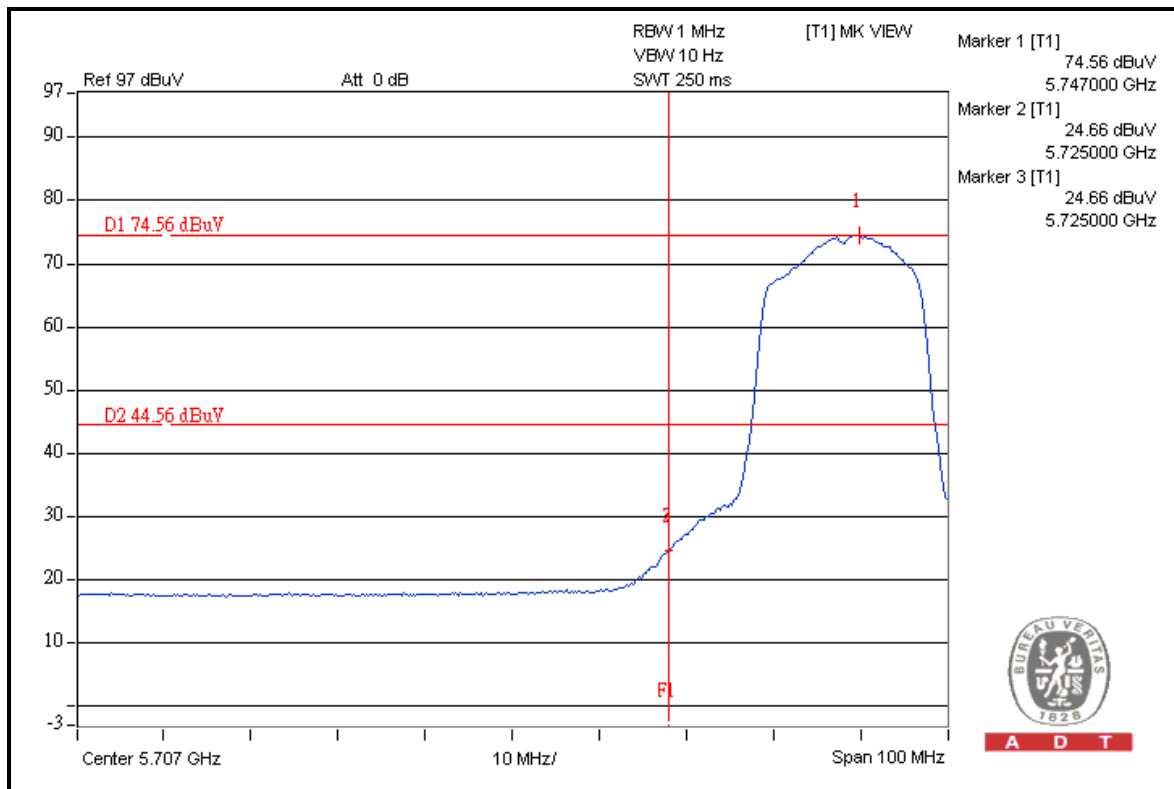
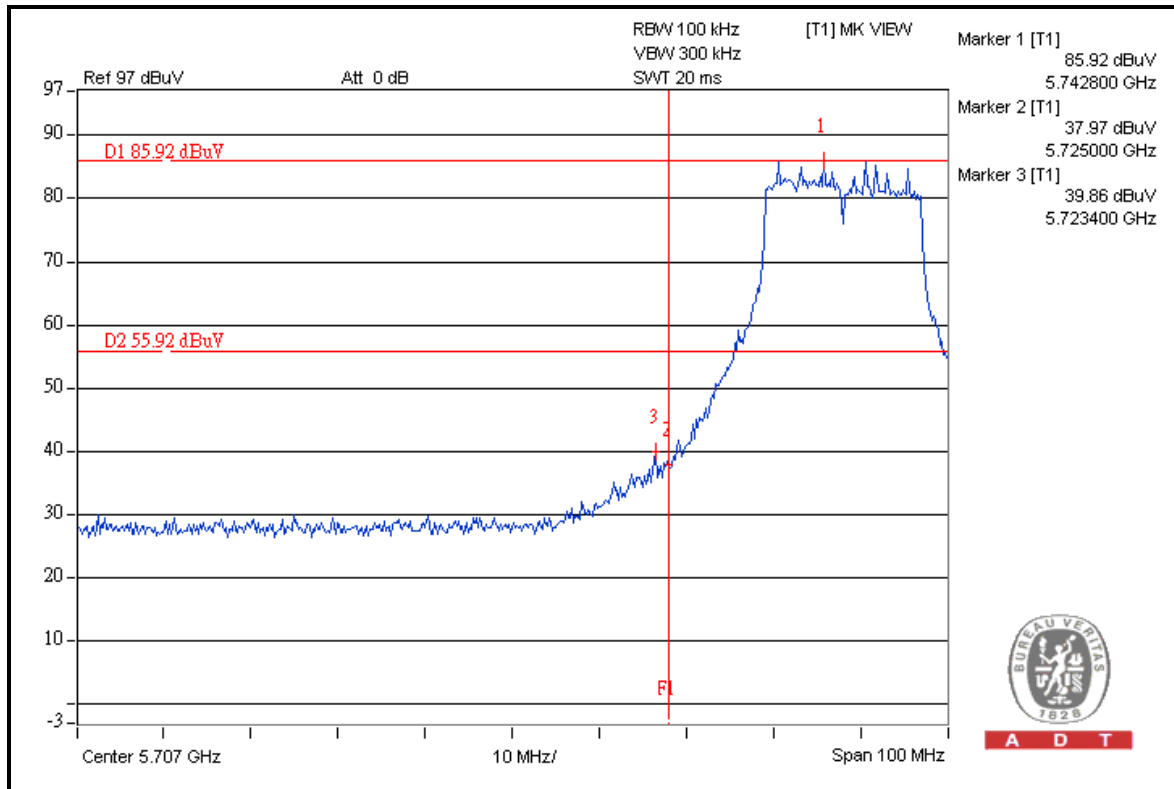



A D T

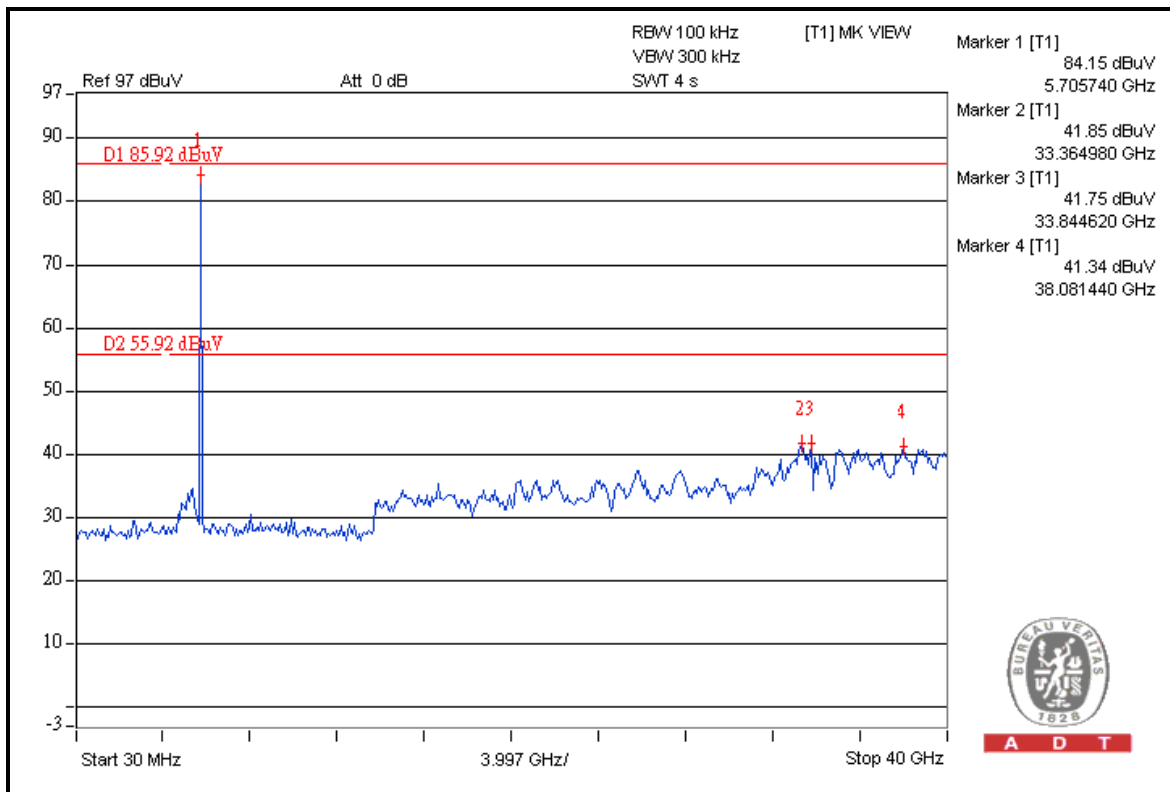

A D T

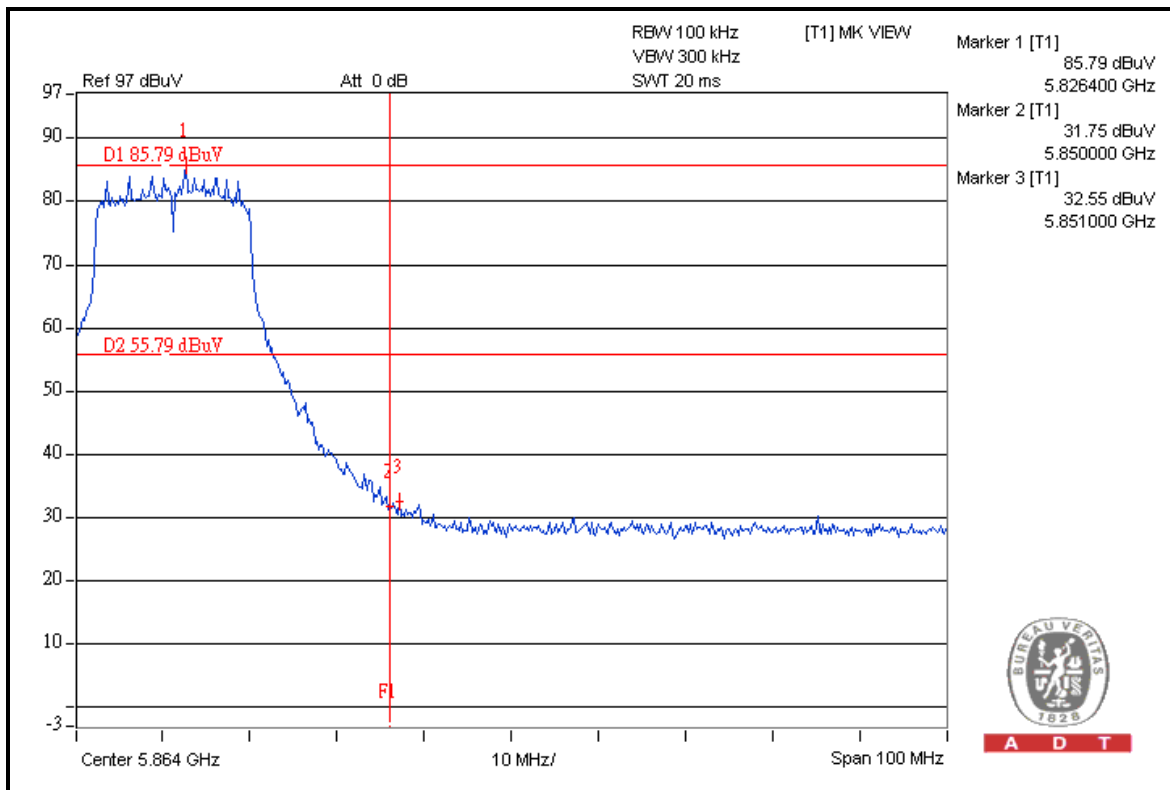

A D T



A D T

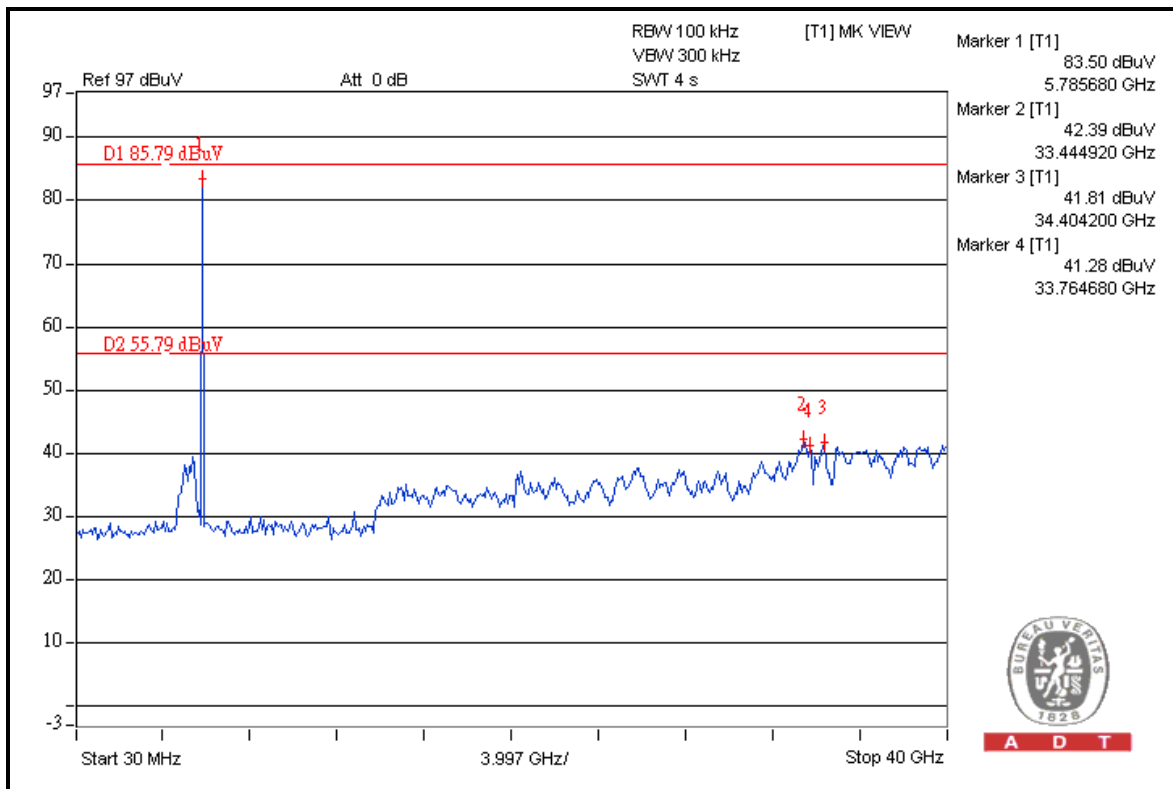
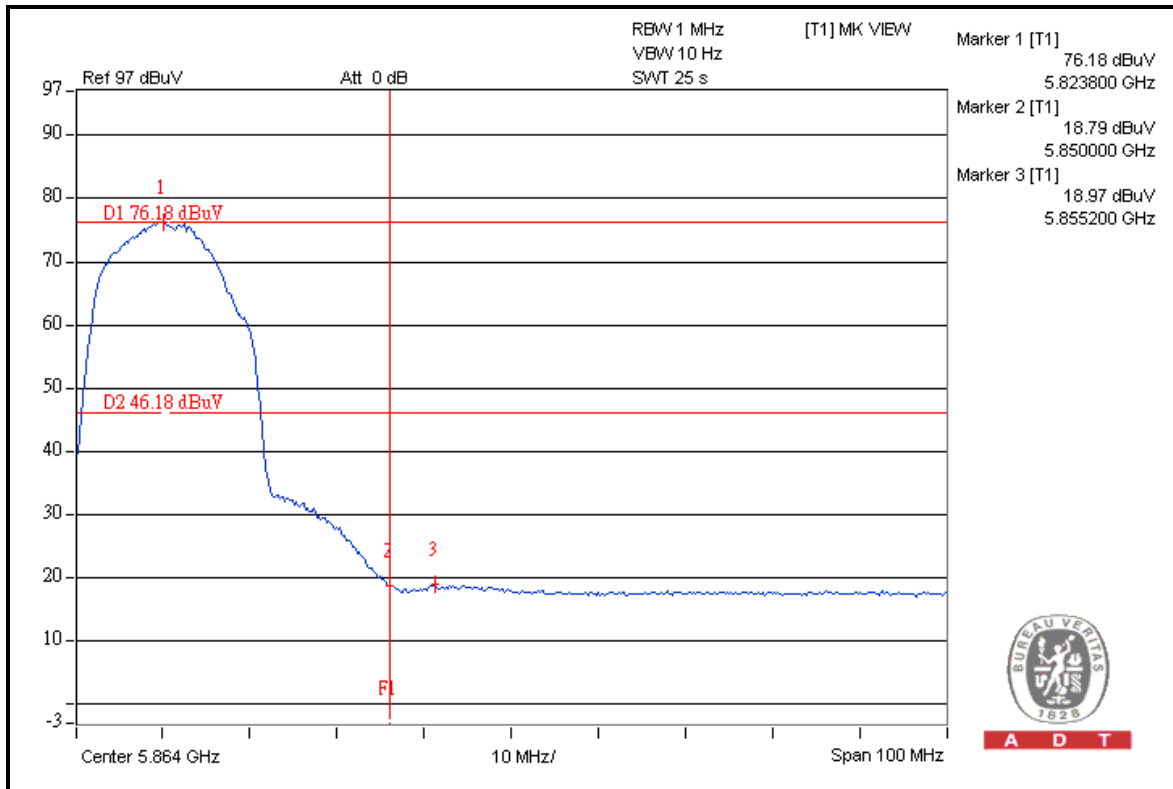



A D T

DRAFT 802.11n (40MHz) OFDM MODULATION

For Mode A:

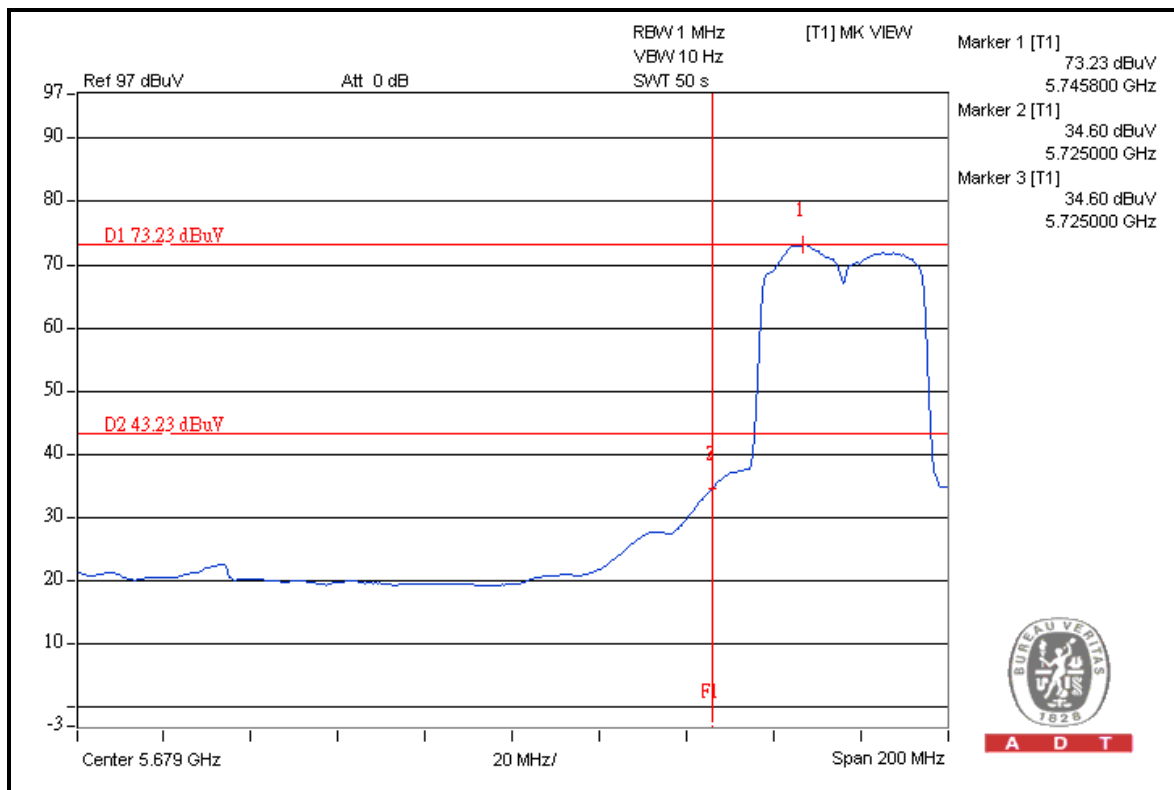
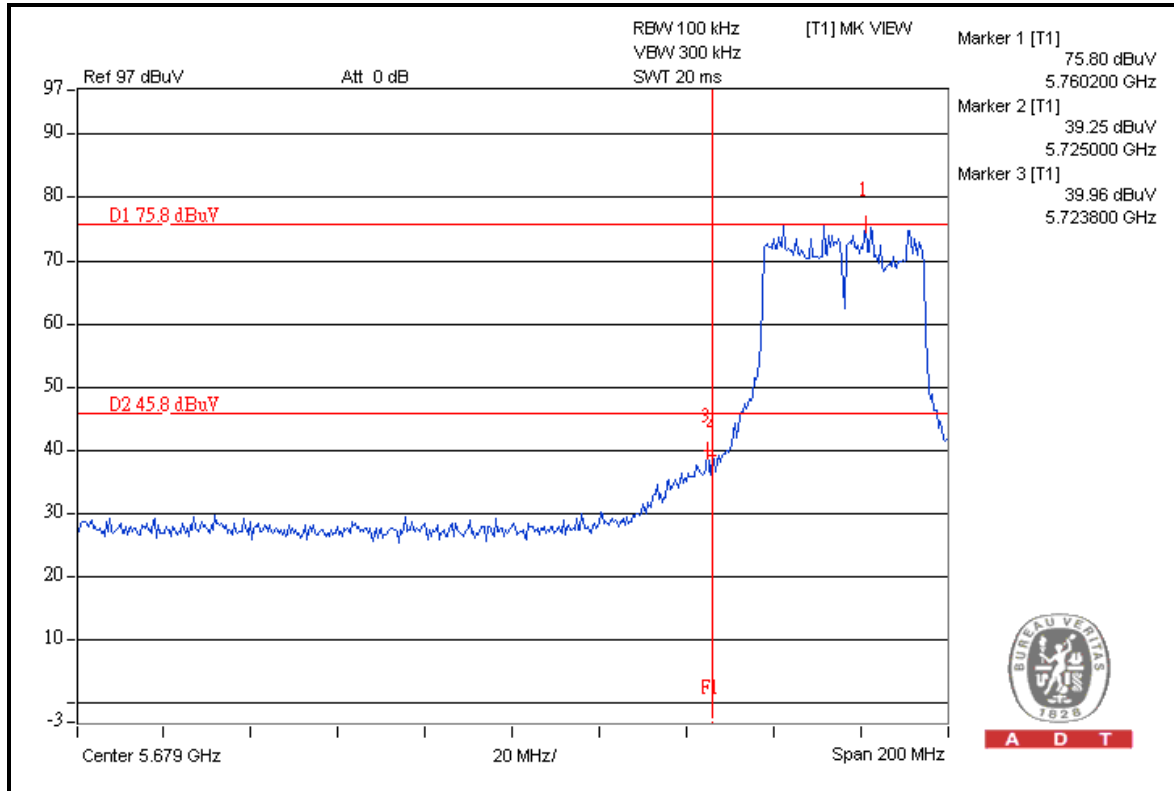



A D T

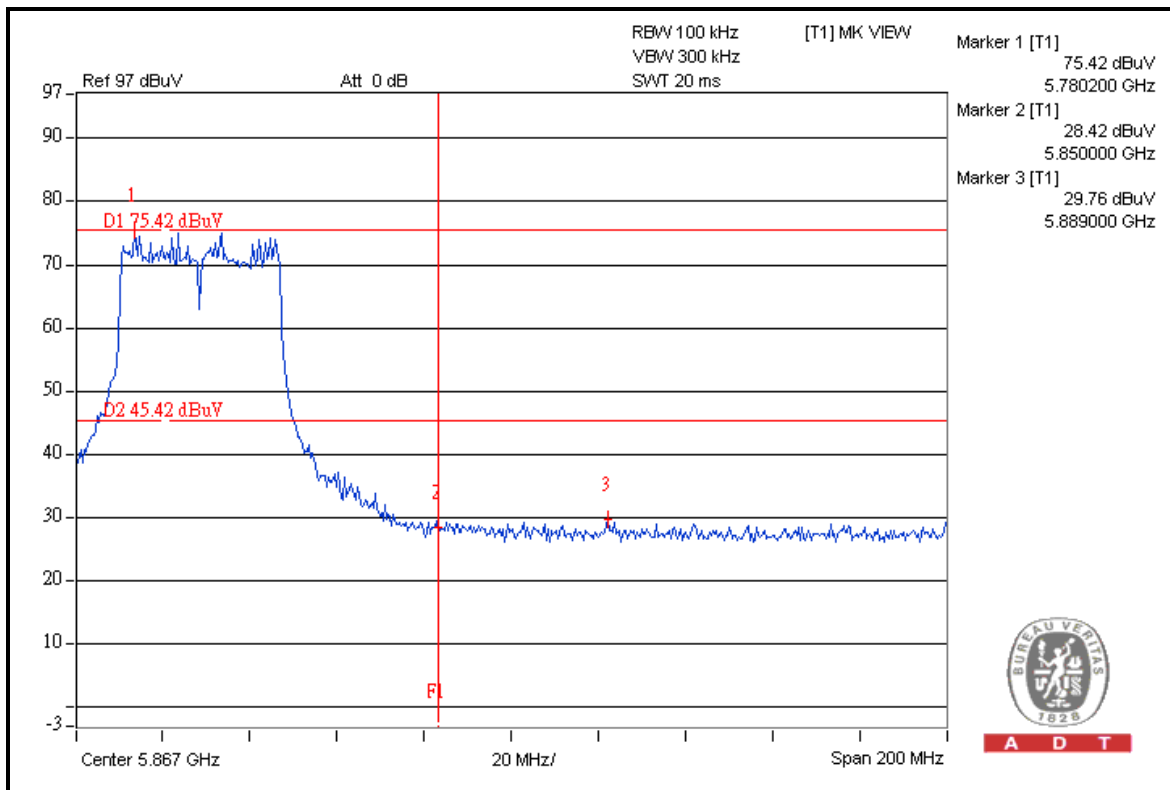
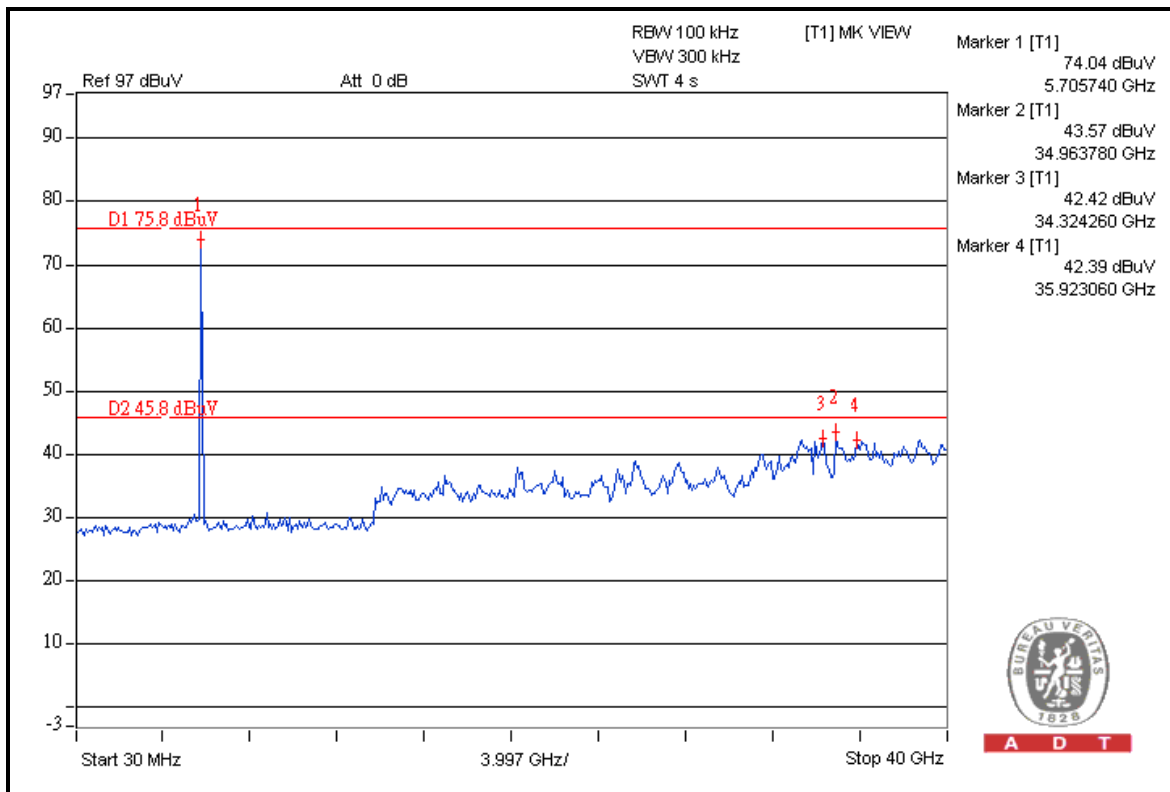



A D T

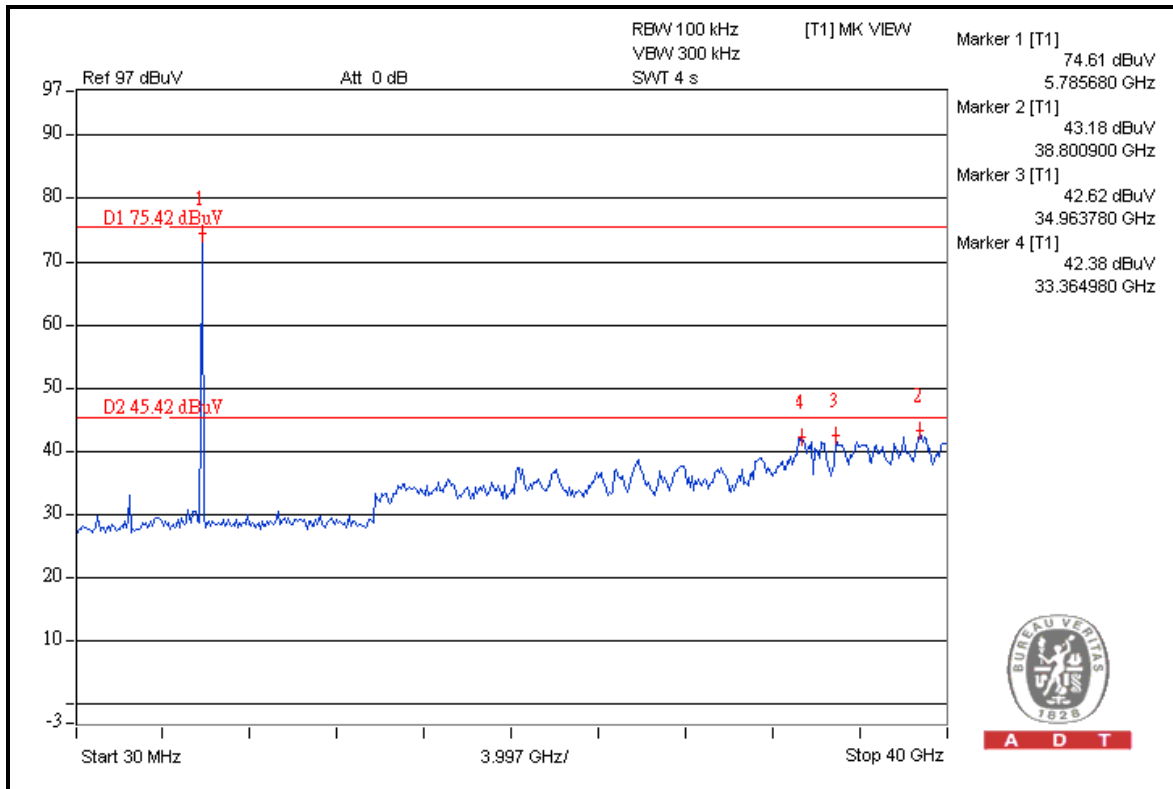
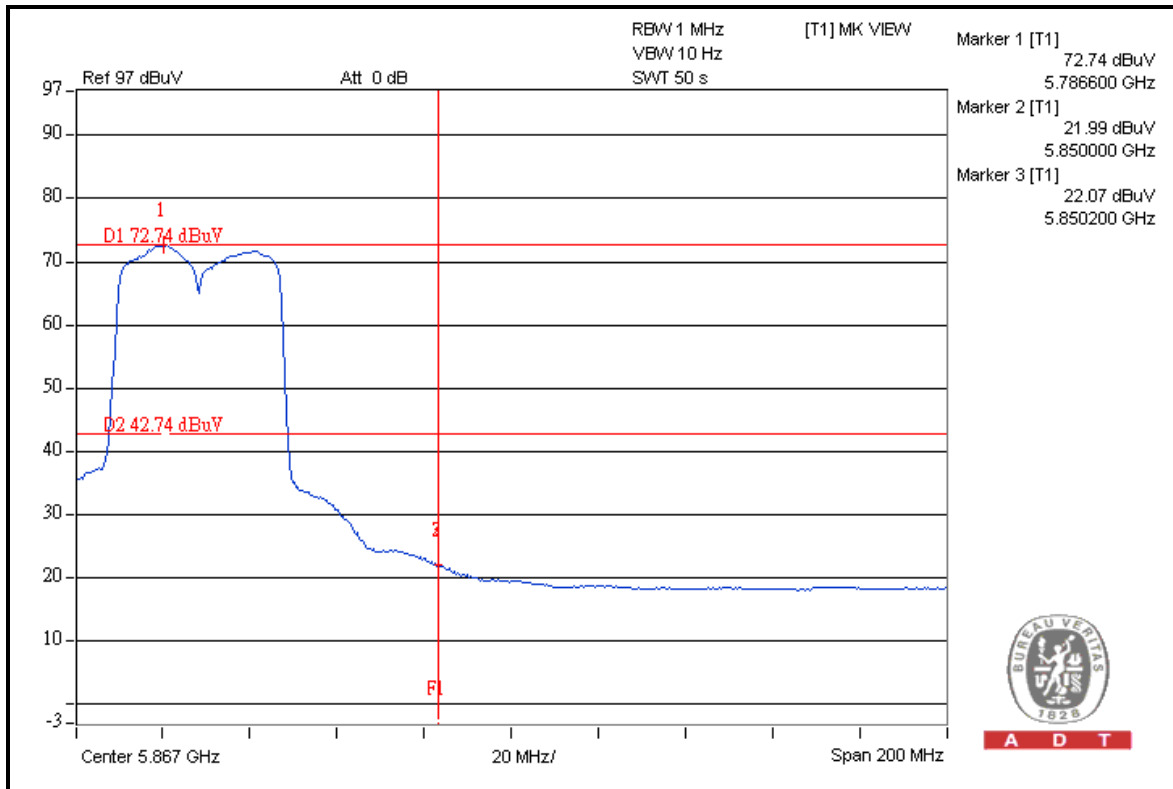



A D T

For Mode C:

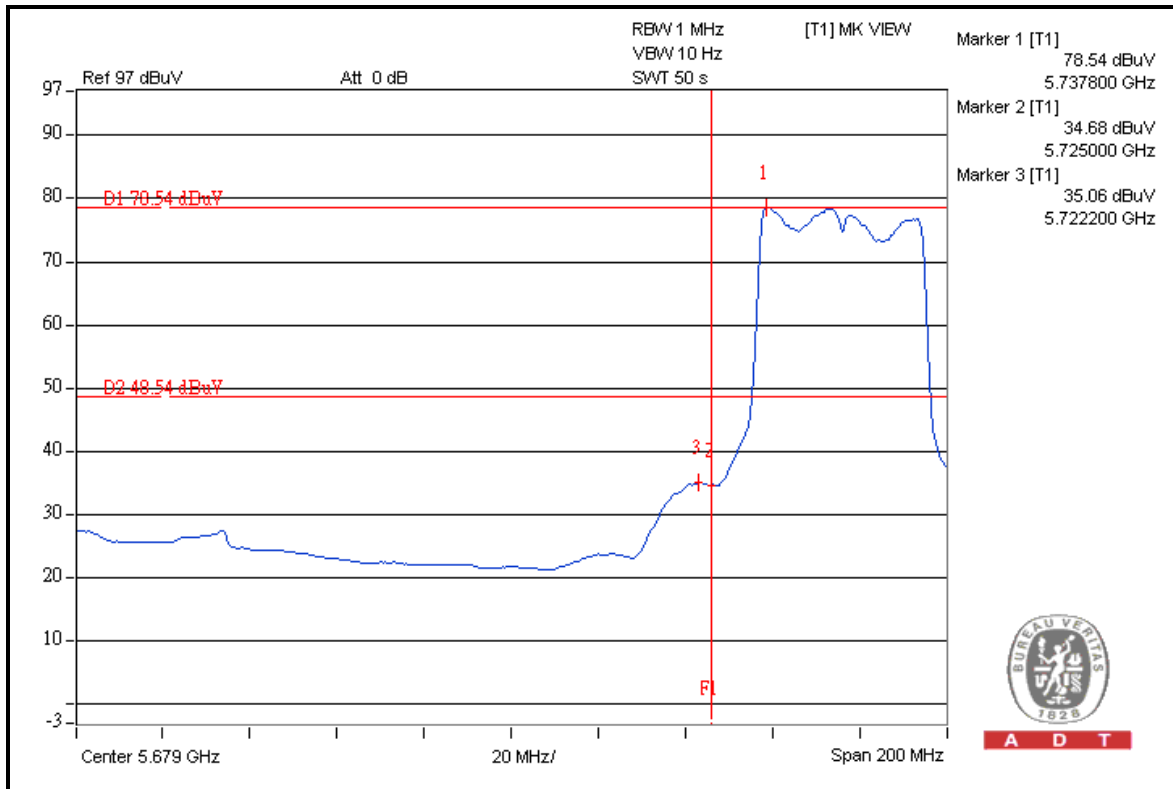
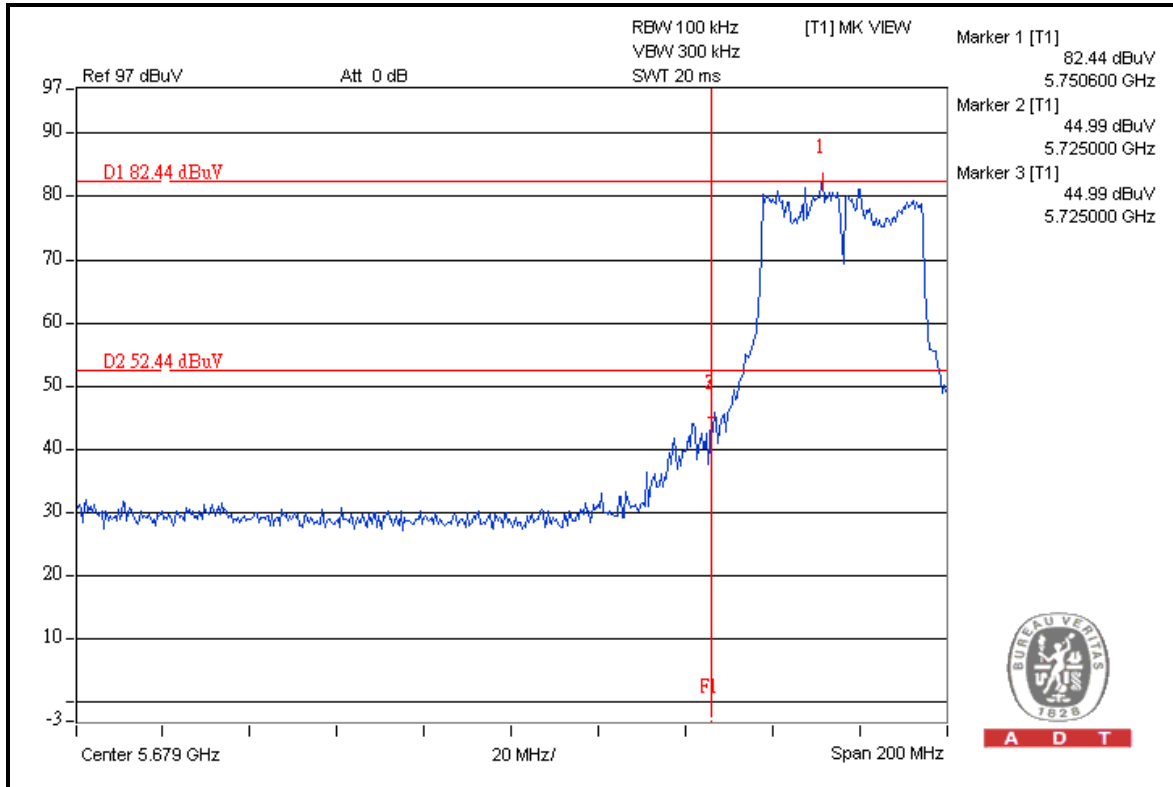



A D T

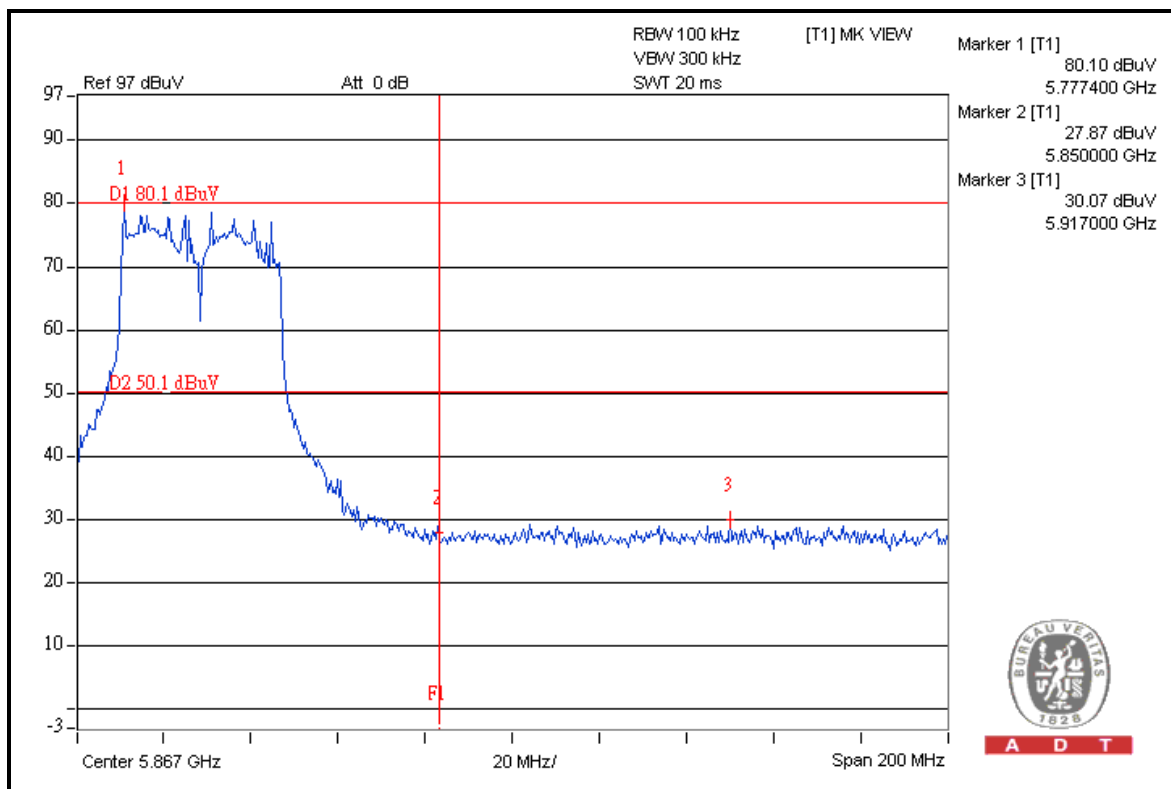
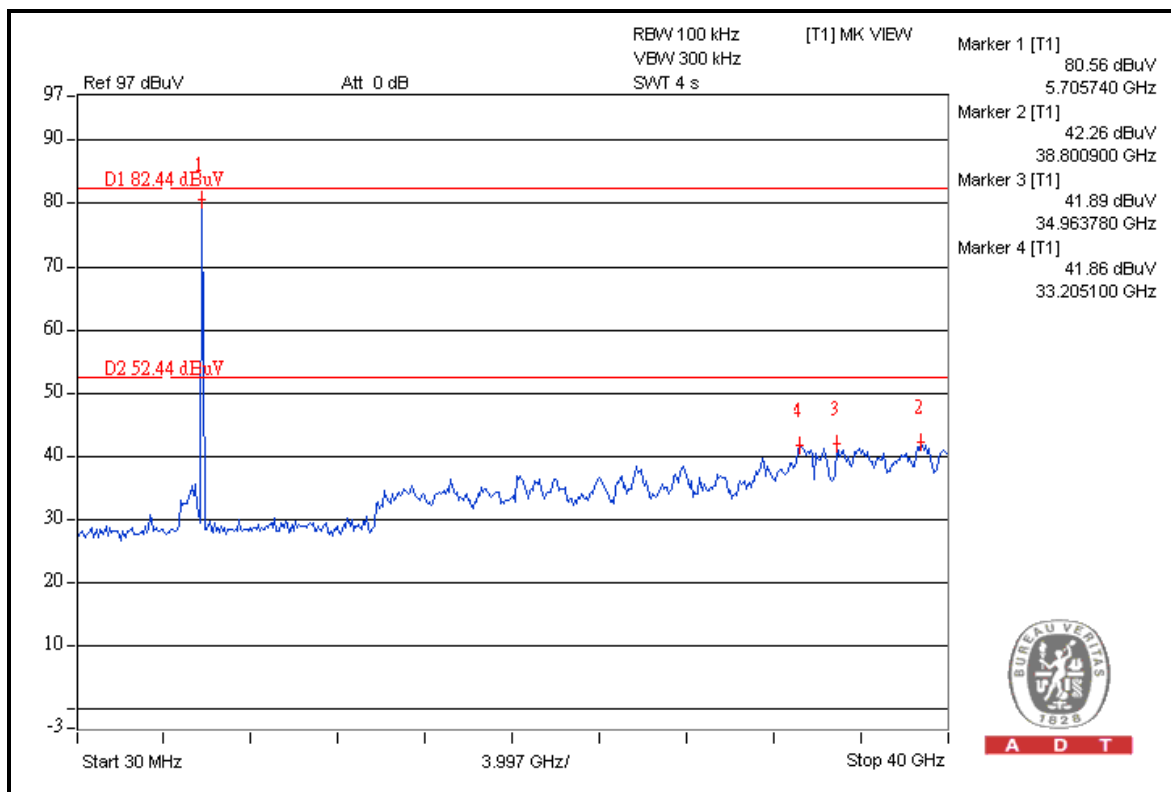



A D T

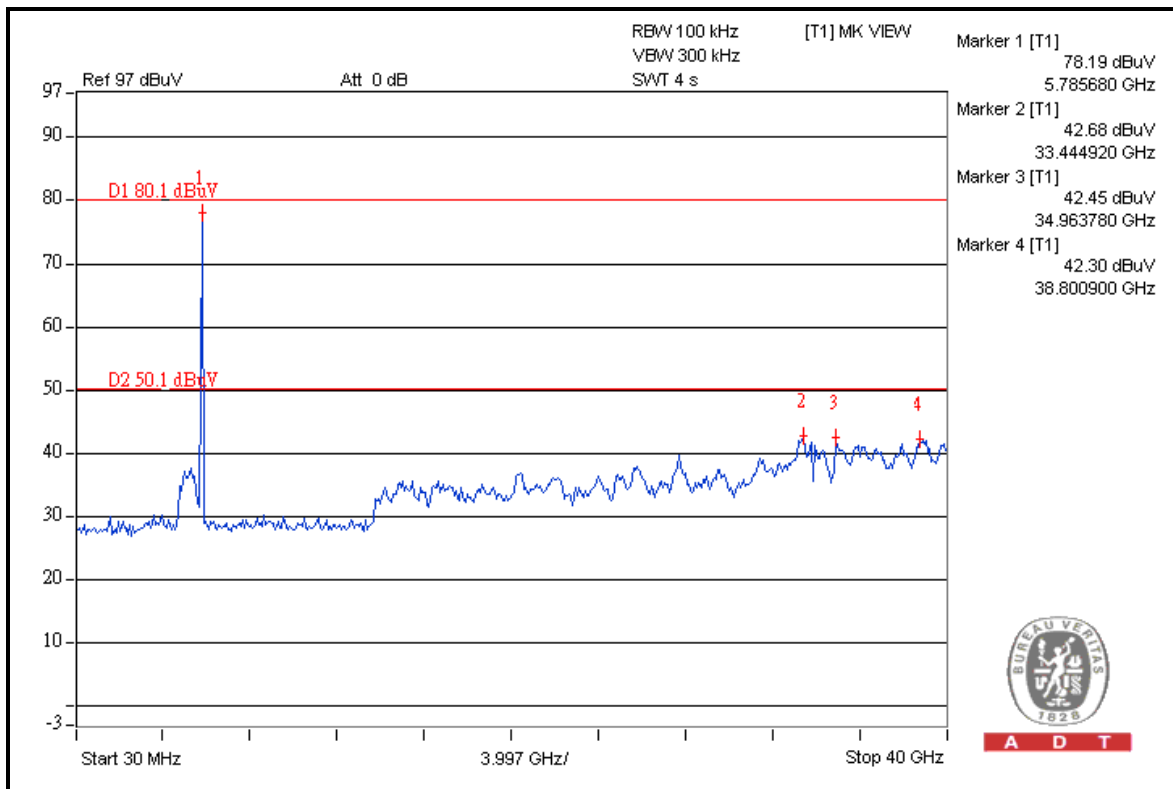
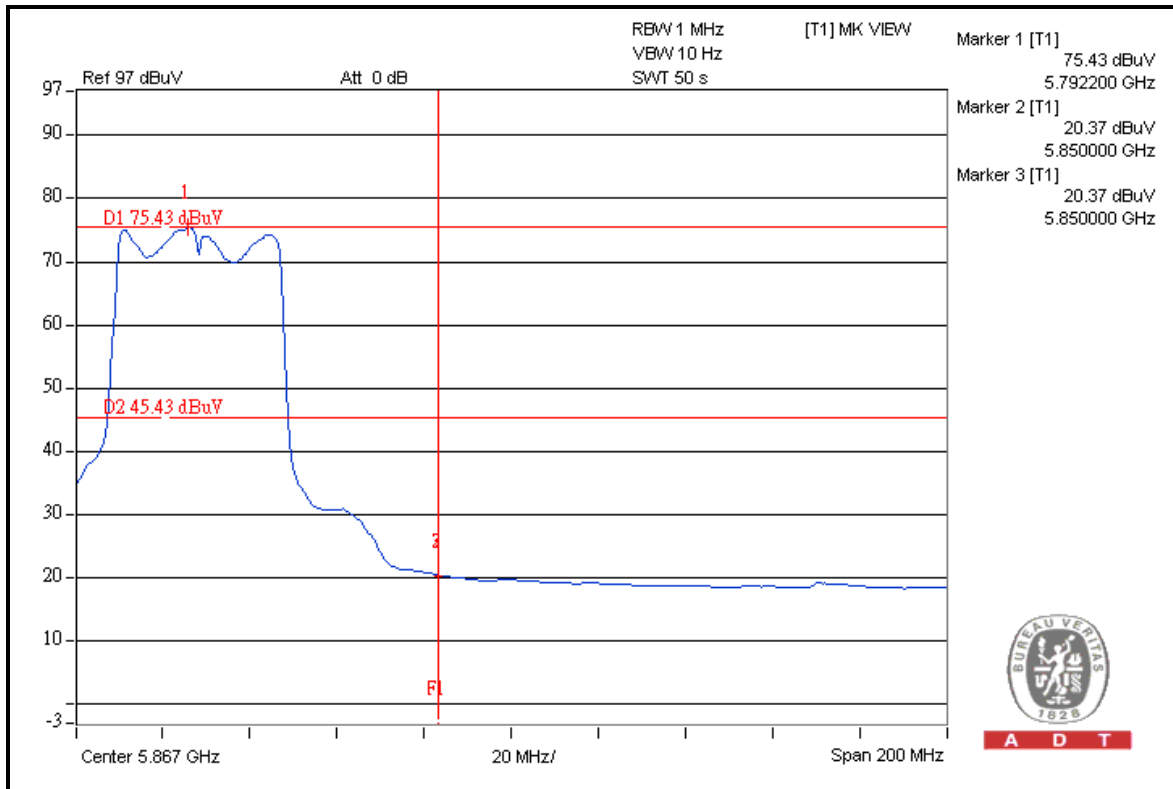

4.7 ANTENNA REQUIREMENT

4.7.1 STANDARD APPLICABLE

For intentional device, according to FCC 47 CFR Section 15.203, an intentional radiator shall be designed to ensure that no antenna other than that furnished by the responsible party shall be used with the device.

And according to FCC 47 CFR Section 15.247(a), if transmitting antennas of directional gain greater than 6dBi are used, the power shall be reduced by the amount in dB that the directional gain of the antenna exceeds 6dBi.

4.7.2 ANTENNA CONNECTED CONSTRUCTION

The antennas used in this product are internal: Patch antenna with U.FL connector and external: Patch antenna with N-Type connector. The maximum gain of the antenna is 23dBi.



A D T

5. PHOTOGRAPHS OF THE TEST CONFIGURATION

Please refer to the attached file (Test Setup Photo).



A D T

6. INFORMATION ON THE TESTING LABORATORIES

We, Bureau Veritas Consumer Products Services (H.K.) Ltd., Taoyuan Branch, were founded in 1988 to provide our best service in EMC, Radio, Telecom and Safety consultation. Our laboratories are accredited and approved by the following approval agencies according to ISO/IEC 17025.

USA	FCC, NVLAP
Germany	TUV Rheinland
Japan	VCCI
Norway	NEMKO
Canada	INDUSTRY CANADA, CSA
R.O.C.	TAF, BSMI, NCC
Netherlands	Telefication
Singapore	GOST-ASIA(MOU)
Russia	CERTIS(MOU)

Copies of accreditation certificates of our laboratories obtained from approval agencies can be downloaded from our web site:

www.adt.com.tw/index.5/phtml. If you have any comments, please feel free to contact us at the following:

Linko EMC/RF Lab:

Tel: 886-2-26052180

Fax: 886-2-26051924

Hsin Chu EMC/RF Lab:

Tel: 886-3-5935343

Fax: 886-3-5935342

Hwa Ya EMC/RF/Safety Telecom Lab:

Tel: 886-3-3183232

Fax: 886-3-3185050

Web Site: www.adt.com.tw

The address and road map of all our labs can be found in our web site also.



A D T

7. APPENDIX A - MODIFICATIONS RECORDERS FOR ENGINEERING CHANGES TO THE EUT BY THE LAB

No any modifications are made to the EUT by the lab during the test.

---END---