



FCC TEST REPORT

REPORT NO.: RF970930L08

MODEL NO.: ESR-9752 (Refer to item 3.1 for more detail)

RECEIVED: Sep. 26, 2008

TESTED: Sep. 26 ~ Oct. 02, 2008

ISSUED: Oct. 07, 2008

APPLICANT: Senao Networks Inc.

ADDRESS: 3F, No. 529, Chung Cheng Rd., Hsintien, Taipei,
Taiwan, R.O.C.

ISSUED BY: Advance Data Technology Corporation

LAB ADDRESS: No. 47, 14th Ling, Chia Pau Tsuen, Lin Kou
Hsiang, Taipei Hsien 244, Taiwan, R.O.C.

TEST LOCATION: No. 19, Hwa Ya 2nd Rd, Wen Hwa Tsuen, Kwei
Shan Hsiang, Taoyuan Hsien 333, Taiwan,
R.O.C.

This test report consists of 92 pages in total. It may be duplicated completely for legal use with the approval of the applicant. It should not be reproduced except in full, without the written approval of our laboratory. The client should not use it to claim product endorsement by TAF or any government agencies. The test results in the report only apply to the tested sample.





TABLE OF CONTENTS

1.	CERTIFICATION.....	4
2.	SUMMARY OF TEST RESULTS	5
2.1	MEASUREMENT UNCERTAINTY	5
3.	GENERAL INFORMATION.....	6
3.1	GENERAL DESCRIPTION OF EUT	6
3.2	DESCRIPTION OF TEST MODES	8
3.2.1	CONFIGURATION OF SYSTEM UNDER TEST	9
3.2.2	TEST MODE APPLICABILITY AND TESTED CHANNEL DETAIL	10
3.3	GENERAL DESCRIPTION OF APPLIED STANDARDS	12
3.4	DESCRIPTION OF SUPPORT UNITS	12
4.	TEST TYPES AND RESULTS	13
4.1	RADIATED EMISSION MEASUREMENT	13
4.1.1	LIMITS OF RADIATED EMISSION MEASUREMENT	13
4.1.2	TEST INSTRUMENTS.....	14
4.1.3	TEST PROCEDURES	15
4.1.4	DEVIATION FROM TEST STANDARD.....	15
4.1.5	TEST SETUP	16
4.1.6	EUT OPERATING CONDITIONS	16
4.1.7	TEST RESULTS	17
4.2	CONDUCTED EMISSION MEASUREMENT	31
4.2.1	LIMITS OF CONDUCTED EMISSION MEASUREMENT	31
4.2.2	TEST INSTRUMENTS.....	31
4.2.3	TEST PROCEDURES	32
4.2.4	DEVIATION FROM TEST STANDARD.....	32
4.2.5	TEST SETUP	33
4.2.6	EUT OPERATING CONDITIONS	33
4.2.7	TEST RESULTS	34
4.3	6dB BANDWIDTH MEASUREMENT	38
4.3.1	LIMITS OF 6dB BANDWIDTH MEASUREMENT	38
4.3.2	TEST INSTRUMENTS.....	38
4.3.3	TEST PROCEDURE.....	38
4.3.4	DEVIATION FROM TEST STANDARD.....	38
4.3.5	TEST SETUP	39
4.3.6	EUT OPERATING CONDITIONS	39
4.3.7	TEST RESULTS	40
4.4	MAXIMUM PEAK OUTPUT POWER.....	52
4.4.1	LIMITS OF MAXIMUM PEAK OUTPUT POWER MEASUREMENT	52
4.4.2	INSTRUMENTS.....	52
4.4.3	TEST PROCEDURES	52
4.4.4	DEVIATION FROM TEST STANDARD.....	53
4.4.5	TEST SETUP	53
4.4.6	EUT OPERATING CONDITIONS	53
4.4.7	TEST RESULTS	54
4.5	POWER SPECTRAL DENSITY MEASUREMENT	56
4.5.1	LIMITS OF POWER SPECTRAL DENSITY MEASUREMENT	56



4.5.2	TEST INSTRUMENTS.....	56
4.5.3	TEST PROCEDURE.....	56
4.5.4	DEVIATION FROM TEST STANDARD.....	57
4.5.5	TEST SETUP.....	57
4.5.6	EUT OPERATING CONDITION.....	57
4.5.7	TEST RESULTS.....	58
4.6	BAND EDGES MEASUREMENT.....	70
4.6.1	LIMITS OF BAND EDGES MEASUREMENT.....	70
4.6.2	TEST INSTRUMENTS.....	70
4.6.3	TEST PROCEDURE.....	71
4.6.4	DEVIATION FROM TEST STANDARD.....	72
4.6.5	EUT OPERATING CONDITION.....	72
4.6.6	TEST RESULTS.....	73
4.7	ANTENNA REQUIREMENT.....	89
4.7.1	STANDARD APPLICABLE.....	89
4.7.2	ANTENNA CONNECTED CONSTRUCTION.....	89
5.	PHOTOGRAPHS OF THE TEST CONFIGURATION.....	90
6.	INFORMATION ON THE TESTING LABORATORIES.....	91
7.	APPENDIX A - MODIFICATIONS RECORDERS FOR ENGINEERING CHANGES TO THE EUT BY THE LAB.....	92



1. CERTIFICATION

PRODUCT: 802.11n Broadband Router

MODEL: ESR-9752 (Refer to item 3.1 for more detail)

BRAND: EnGenius (Refer to item 3.1 for more detail)

APPLICANT: Senao Networks Inc.

TEST SAMPLE: ENGINEERING SAMPLE

TESTED: Sep. 26 ~ Oct. 02, 2008

STANDARDS: **FCC Part 15, Subpart C (Section 15.247)**

ANSI C63.4-2003

The above equipment (Model: ESR-9752) has been tested by **Advance Data Technology Corporation**, and found compliance with the requirement of the above standards. The test record, data evaluation & Equipment Under Test (EUT) configurations represented herein are true and accurate accounts of the measurements of the sample's EMC characteristics under the conditions specified in this report.

PREPARED BY : Ivy Lin , **DATE:** Oct. 07, 2008
Ivy Lin / Specialist

TECHNICAL ACCEPTANCE : Long Chen , **DATE:** Oct. 07, 2008
Responsible for RF Long Chen / Senior Engineer

APPROVED BY : Gary Chang , **DATE:** Oct. 07, 2008
Gary Chang / Assistant Manager

2. SUMMARY OF TEST RESULTS

The EUT has been tested according to the following specifications:

APPLIED STANDARD: FCC PART 15, SUBPART C (SECTION 15.247)			
STANDARD SECTION	TEST TYPE AND LIMIT	RESULT	REMARK
15.207	AC Power Conducted Emission	PASS	Meet the requirement of limit. Minimum passing margin is -11.87dB at 0.887MHz
15.247(a)(2)	Spectrum Bandwidth of a Direct Sequence Spread Spectrum System Limit: min. 500kHz	PASS	Meet the requirement of limit.
15.247(b)	Maximum Peak Output Power Limit: max. 30dBm	PASS	Meet the requirement of limit.
15.247(d)	Radiated Emissions Limit: Table 15.209	PASS	Meet the requirement of limit. Minimum passing margin is -1.01dB at 2483.50MHz
15.247(e)	Power Spectral Density Limit: max. 8dBm	PASS	Meet the requirement of limit.
15.247(d)	Band Edge Measurement Limit: 20dB less than the peak value of fundamental frequency	PASS	Meet the requirement of limit.

2.1 MEASUREMENT UNCERTAINTY

Where relevant, the following measurement uncertainty levels have been estimated for tests performed on the EUT as specified in CISPR 16-4-2:

MEASUREMENT	FREQUENCY	UNCERTAINTY
Conducted emissions	9kHz ~ 30MHz	2.44 dB
Radiated emissions	30MHz ~ 200MHz	3.34 dB
	200MHz ~1000MHz	3.35 dB
	1GHz ~ 18GHz	2.26 dB
	18GHz ~ 40GHz	1.94 dB

This uncertainty represents an expanded uncertainty expressed at approximately the 95% confidence level using a coverage factor of $k = 2$.

3. GENERAL INFORMATION

3.1 GENERAL DESCRIPTION OF EUT

EUT	802.11n Broadband Router
MODEL NO.	ESR-9752 (Refer to Note 1 for more detail)
FCC ID	U2M-SR97908003
POWER SUPPLY	12Vdc from AC adapter
MODULATION TYPE	CCK, DQPSK, DBPSK for DSSS 64QAM, 16QAM, QPSK, BPSK for OFDM
MODULATION TECHNOLOGY	DSSS, OFDM
TRANSFER RATE	802.11b:11.0/ 5.5/ 2.0/ 1.0Mbps 802.11g: 54.0/ 48.0/ 36.0/ 24.0/ 18.0/ 12.0/ 9.0/ 6.0Mbps Draft 802.11n: up to 300.0Mbps
FREQUENCY RANGE	2400.0 ~ 2483.5MHz
NUMBER OF CHANNEL	11 for 802.11b, 802.11g, draft 802.11n (20MHz) 7 for draft 802.11n (40MHz)
OUTPUT POWER	324.370mW
ANTENNA TYPE	Dipole antenna with 2.0dBi gain
DATA CABLE	NA
I/O PORTS	RJ45
ACCESSORY DEVICES	Adapter

NOTE:

- The models as below are identical to each other except for their model name and brand name due to marketing requirement.

BRAND	MODEL
EnGenius	ESR-9752
corega	CG-WLBARN20
Rosewill	RNX-EasyN4

- The EUT incorporates a MIMO function. Physically, the EUT provides two completed transmitters and two receivers.

MODULATION MODE	TX FUNCTION
802.11b	1TX
802.11g	1TX
Draft 802.11n (20MHz)	2TX
Draft 802.11n (40MHz)	2TX

- The EUT has two samples as below are identical to each other except for their antenna connector.

Sample	Antenna Brand	Antenna Model	Antenna type	Antenna connector	Gain (dBi)
1	Lct	FSB-18013G-00W	Dipole	NA	2 dBi
2	JOYMAX	IWX-2411RSXX	Dipole	R-SMA	2 dBi

4. The EUT was powered by the following adapter:

BRAND:	corega
MODEL:	MT12-Y120100-A1
INPUT:	100-120Vac, 50/60Hz, 0.3A
OUTPUT:	12Vdc, 1.0A
POWER LINE:	1.8m non-shielded cable without core

5. The above EUT information was declared by manufacturer and for more detailed features description, please refer to the manufacturer's specifications or user's manual.

3.2 DESCRIPTION OF TEST MODES

11 channels are provided for 802.11b, 802.11g and draft 802.11n (20MHz):

CHANNEL	FREQUENCY	CHANNEL	FREQUENCY
1	2412MHz	7	2442MHz
2	2417MHz	8	2447MHz
3	2422MHz	9	2452MHz
4	2427MHz	10	2457MHz
5	2432MHz	11	2462MHz
6	2437MHz		

7 channels are provided for draft 802.11n (40MHz):

CHANNEL	FREQUENCY	CHANNEL	FREQUENCY
1	2422MHz	5	2442MHz
2	2427MHz	6	2447MHz
3	2432MHz	7	2452MHz
4	2437MHz		

3.2.1 CONFIGURATION OF SYSTEM UNDER TEST

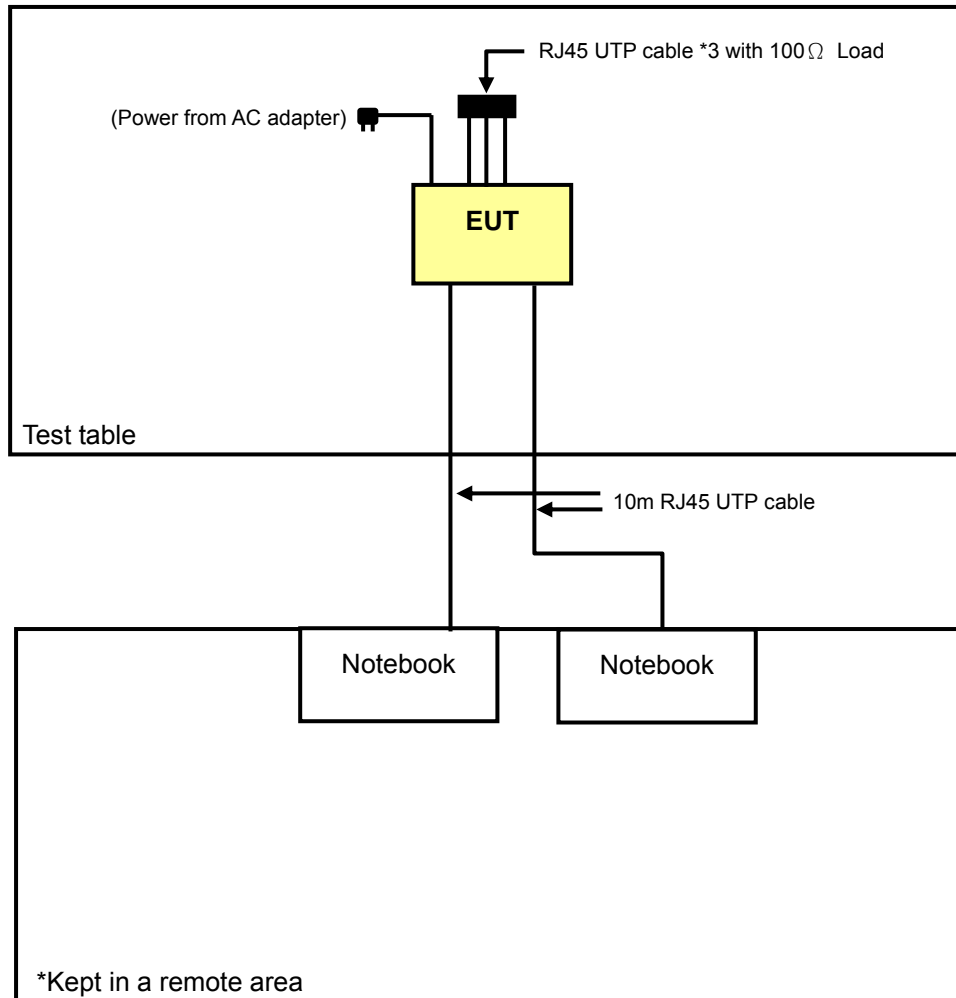

3.2.2 TEST MODE APPLICABILITY AND TESTED CHANNEL DETAIL

EUT CONFIGURE MODE	APPLICABLE TO				DESCRIPTION
	RE \geq 1G	RE<1G	PLC	APCM	
A	√	√	√	√	Sample 1 without antenna connector
B	-	√	√	-	Sample 2 with R-SMA connector

Where **RE \geq 1G**: Radiated Emission above 1GHz **RE<1G**: Radiated Emission below 1GHz
PLC: Power Line Conducted Emission **APCM**: Antenna Port Conducted Measurement

NOTE: “_” means no effect.

RADIATED EMISSION TEST (ABOVE 1GHz):

- Pre-Scan has been conducted to determine the worst-case mode from all possible combinations between available modulations, data rates, XYZ Axis and antenna ports (if EUT with antenna diversity architecture).
- Following channel(s) was (were) selected for the final test as listed below.

EUT CONFIGURE MODE	MODE	AVAILABLE CHANNEL	TESTED CHANNEL	MODULATION TECHNOLOGY	MODULATION TYPE	DATA RATE (Mbps)	AXIS
A	802.11b	1 to 11	1, 6, 11	DSSS	DBPSK	1.0	X
	802.11g	1 to 11	1, 6, 11	OFDM	BPSK	6.0	
	Draft 802.11n (20MHz)	1 to 11	1, 6, 11	OFDM	BPSK	7.2	
	Draft 802.11n (40MHz)	1 to 7	1, 4, 7	OFDM	BPSK	15.0	

RADIATED EMISSION TEST (BELOW 1GHz):

- Pre-Scan has been conducted to determine the worst-case mode from all possible combinations between available modulations, data rates, XYZ Axis and antenna ports (if EUT with antenna diversity architecture).
- Following channel(s) was (were) selected for the final test as listed below.

EUT CONFIGURE MODE	MODE	AVAILABLE CHANNEL	TESTED CHANNEL	MODULATION TECHNOLOGY	MODULATION TYPE	DATA RATE (Mbps)	AXIS
A, B	Draft 802.11n (20MHz)	1 to 11	11	OFDM	BPSK	7.2	X

POWER LINE CONDUCTED EMISSION TEST:

- Pre-Scan has been conducted to determine the worst-case mode from all possible combinations between available modulations, data rates and antenna ports (if EUT with antenna diversity architecture).
- Following channel(s) was (were) selected for the final test as listed below.

EUT CONFIGURE MODE	MODE	AVAILABLE CHANNEL	TESTED CHANNEL	MODULATION TECHNOLOGY	MODULATION TYPE	DATA RATE (Mbps)
A, B	Draft 802.11n (20MHz)	1 to 11	11	OFDM	BPSK	7.2

BANDEDGE MEASUREMENT:

- Pre-Scan has been conducted to determine the worst-case mode from all possible combinations between available modulations, data rates and antenna ports (if EUT with antenna diversity architecture).
- Following channel(s) was (were) selected for the final test as listed below.

EUT CONFIGURE MODE	MODE	AVAILABLE CHANNEL	TESTED CHANNEL	MODULATION TECHNOLOGY	MODULATION TYPE	DATA RATE (Mbps)
A	802.11b	1 to 11	1, 6, 11	DSSS	DBPSK	1.0
	802.11g	1 to 11	1, 6, 11	OFDM	BPSK	6.0
	Draft 802.11n (20MHz)	1 to 11	1, 6, 11	OFDM	BPSK	7.2
	Draft 802.11n (40MHz)	1 to 7	1, 4, 7	OFDM	BPSK	15.0

ANTENNA PORT CONDUCTED MEASUREMENT:

- Pre-Scan has been conducted to determine the worst-case mode from all possible combinations between available modulations, data rates and antenna ports (if EUT with antenna diversity architecture).
- Following channel(s) was (were) selected for the final test as listed below.

EUT CONFIGURE MODE	MODE	AVAILABLE CHANNEL	TESTED CHANNEL	MODULATION TECHNOLOGY	MODULATION TYPE	DATA RATE (Mbps)
A	802.11b	1 to 11	1, 6, 11	DSSS	DBPSK	1.0
	802.11g	1 to 11	1, 6, 11	OFDM	BPSK	6.0
	Draft 802.11n (20MHz)	1 to 11	1, 6, 11	OFDM	BPSK	7.2
	Draft 802.11n (40MHz)	1 to 7	1, 4, 7	OFDM	BPSK	15.0



3.3 GENERAL DESCRIPTION OF APPLIED STANDARDS

The EUT is a RF Product. According to the specifications of the manufacturer, it must comply with the requirements of the following standards:

FCC Part 15, Subpart C (15.247)

ANSI C63.4-2003

All test items have been performed and recorded as per the above standards.

NOTE: The EUT is also considered as a kind of computer peripheral, because the connection to computer is necessary for typical use. It has been verified to comply with the requirements of FCC Part 15, Subpart B, Class B (DoC). The test report has been issued separately.

3.4 DESCRIPTION OF SUPPORT UNITS

The EUT has been tested as an independent unit together with other necessary accessories or support units. The following support units or accessories were used to form a representative test configuration during the tests.

NO.	PRODUCT	BRAND	MODEL NO.	SERIAL NO.	FCC ID
1	NOTEBOOK	DELL	PP05L	12130898320	E2K24CLNS
2	NOTEBOOK	DELL	PP05L	16484462992	E2K24CLNS

NO.	SIGNAL CABLE DESCRIPTION OF THE ABOVE SUPPORT UNITS
1	10m UTP RJ45 cable
2	10m UTP RJ45 cable

NOTE: 1. All power cords of the above support units are non shielded (1.8m).
2. Items 1 ~ 2 acted as communication partners to transfer data.

4. TEST TYPES AND RESULTS

4.1 RADIATED EMISSION MEASUREMENT

4.1.1 LIMITS OF RADIATED EMISSION MEASUREMENT

Emissions radiated outside of the specified bands, shall be according to the general radiated limits in 15.209 as following:

FREQUENCIES (MHz)	FIELD STRENGTH (microvolts/meter)	MEASUREMENT DISTANCE (meters)
0.009 ~ 0.490	2400/F(kHz)	300
0.490 ~ 1.705	24000/F(kHz)	30
1.705 ~ 30.0	30	30
30 ~ 88	100	3
88 ~ 216	150	3
216 ~ 960	200	3
Above 960	500	3

NOTE:

1. The lower limit shall apply at the transition frequencies.
2. Emission level (dBuV/m) = 20 log Emission level (uV/m).
3. As shown in 15.35(b), for frequencies above 1000MHz, the field strength limits are based on average detector, however, the peak field strength of any emission shall not exceed the maximum permitted average limits, specified above by more than 20dB under any condition of modulation.



4.1.2 TEST INSTRUMENTS

DESCRIPTION & MANUFACTURER	MODEL NO.	SERIAL NO.	DATE OF CALIBRATION	DUE DATE OF CALIBRATION
Test Receiver ROHDE & SCHWARZ	ESI7	100033	Jun. 30, 2008	Jun. 29, 2009
Spectrum Analyzer Agilent	FSP	100041	Apr. 22, 2008	Apr. 21, 2009
BILOG Antenna SCHWARZBECK	VULB9168	9168-160	May, 02, 2008	May, 01, 2009
HORN Antenna SCHWARZBECK	9120D	9120D-209	Jun. 24, 2008	Jun. 23, 2009
HORN Antenna SCHWARZBECK	BBHA 9170	BBHA9170243	Dec. 25, 2007	Dec. 24, 2008
Preamplifier Agilent	8447D	2944A10633	Oct. 29, 2007	Oct. 28, 2008
Preamplifier Agilent	8449B	3008A01964	Oct. 24, 2007	Oct. 23, 2008
RF signal cable HUBER+SUHNNER	SUCOFLEX 104	283402/4	Dec. 07, 2007	Dec. 06, 2008
RF signal cable HUBER+SUHNNER	SUCOFLEX 104	251644/4	Dec. 07, 2007	Dec. 06, 2008
Software ADT.	ADT_Radiated_V7.6	NA	NA	NA
Antenna Tower inn-co GmbH	MA 4000	013303	NA	NA
Antenna Tower Controller inn-co GmbH	CO2000	017303	NA	NA
Turn Table ADT.	TT100.	TT93021703	NA	NA
Turn Table Controller ADT.	SC100.	SC93021703	NA	NA

- NOTE:**
1. The calibration interval of the above test instruments is 12 months and the calibrations are traceable to NML/ROC and NIST/USA.
 2. The test was performed in HwaYa Chamber 3.
 3. The horn antenna and HP preamplifier (model: 8449B) are used only for the measurement of emission frequency above 1GHz if tested.
 4. The FCC Site Registration No. is 988962.
 5. The IC Site Registration No. is IC3789B-3.

4.1.3 TEST PROCEDURES

- a. The EUT was placed on the top of a rotating table 0.8 meters above the ground at a 3 meters semi-anechoic chamber. The table was rotated 360 degrees to determine the position of the highest radiation.
- b. The EUT was set 3 meters away from the interference-receiving antenna, which was mounted on the top of a variable-height antenna tower.
- c. The antenna is a broadband antenna, and its height is varied from one meter to four meters above the ground to determine the maximum value of the field strength. Both horizontal and vertical polarizations of the antenna are set to make the measurement.
- d. For each suspected emission, the EUT was arranged to its worst case and then the antenna was tuned to heights from 1 meter to 4 meters and the rotatable table was turned from 0 degrees to 360 degrees to find the maximum reading.
- e. The test-receiver system was set to Peak Detect Function and Specified Bandwidth with Maximum Hold Mode.
- f. If the emission level of the EUT in peak mode was lower than the limit specified, then testing could be stopped and the peak values of the EUT would be reported. Otherwise the emissions would be re-tested one by one using peak, quasi-peak or average method as specified and then reported in a data sheet.

NOTE:

1. The resolution bandwidth and video bandwidth of test receiver/spectrum analyzer is 120kHz for Quasi-peak detection at frequency below 1GHz.
2. The resolution bandwidth of test receiver/spectrum analyzer is 1MHz and video bandwidth is 3MHz for Peak detection at frequency above 1GHz.
3. The resolution bandwidth of test receiver/spectrum analyzer is 1MHz and the video bandwidth is 10Hz for Average detection (AV) at frequency above 1GHz.
4. All modes of operation were investigated and the worst-case emissions are reported.

4.1.4 DEVIATION FROM TEST STANDARD

No deviation.

4.1.5 TEST SETUP

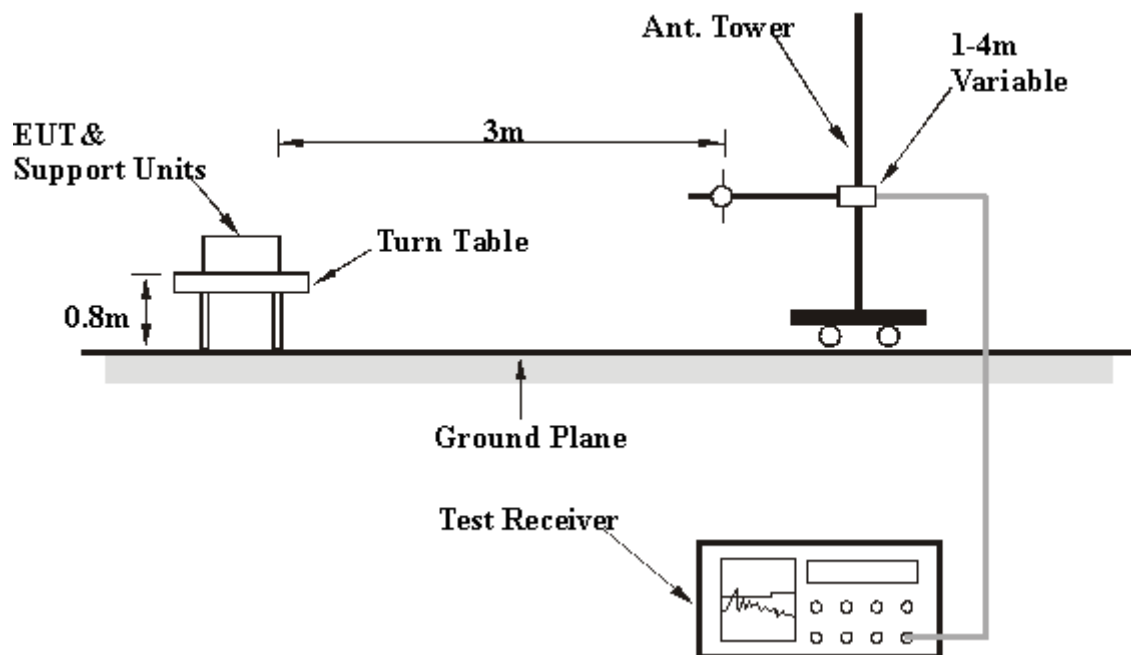

For the actual test configuration, please refer to the attached file (Test Setup Photo).

4.1.6 EUT OPERATING CONDITIONS

- Placed the EUT on the testing table.
- The communication partners connected with EUT via a RJ45 UTP cable and run a test program (provided by manufacturer) to enable EUT under transmission condition continuously at specific channel frequency.
- The communication partner sent data to EUT by command "PING".

4.1.7 TEST RESULTS

802.11b DSSS MODULATION

EUT TEST CONDITION		MEASUREMENT DETAIL	
CHANNEL	Channel 1	FREQUENCY RANGE	1 ~ 25GHz
INPUT POWER (SYSTEM)	120Vac, 60 Hz	DETECTOR FUNCTION	Peak (PK) Average (AV)
ENVIRONMENTAL CONDITIONS	24deg. C, 64%RH 1000hPa	TESTED BY	Match Tsui

ANTENNA POLARITY & TEST DISTANCE: HORIZONTAL AT 3 M								
NO.	FREQ. (MHz)	EMISSION LEVEL (dBuV/m)	LIMIT (dBuV/m)	MARGIN (dB)	ANTENNA HEIGHT (m)	TABLE ANGLE (Degree)	RAW VALUE (dBuV)	CORRECTION FACTOR (dB/m)
1	2386.00	55.49 PK	74.00	-18.51	1.07 H	350	23.06	32.43
2	2386.00	46.66 AV	54.00	-7.34	1.07 H	350	14.23	32.43
3	*2412.00	103.09 PK			1.07 H	350	70.57	32.52
4	*2412.00	98.32 AV			1.07 H	350	65.80	32.52
5	4824.00	52.19 PK	74.00	-21.81	1.21 H	274	13.89	38.30
6	4824.00	44.67 AV	54.00	-9.33	1.21 H	274	6.37	38.30
ANTENNA POLARITY & TEST DISTANCE: VERTICAL AT 3 M								
NO.	FREQ. (MHz)	EMISSION LEVEL (dBuV/m)	LIMIT (dBuV/m)	MARGIN (dB)	ANTENNA HEIGHT (m)	TABLE ANGLE (Degree)	RAW VALUE (dBuV)	CORRECTION FACTOR (dB/m)
1	2386.00	60.24 PK	74.00	-13.76	1.13 V	60	27.81	32.43
2	2386.00	49.49 AV	54.00	-4.51	1.13 V	60	17.06	32.43
3	*2412.00	111.13 PK			1.15 V	57	78.61	32.52
4	*2412.00	106.46 AV			1.15 V	57	73.94	32.52
5	4824.00	56.54 PK	74.00	-17.46	1.29 V	95	18.24	38.30
6	4824.00	52.49 AV	54.00	-1.51	1.29 V	95	14.19	38.30

- REMARKS:**
1. Emission level (dBuV/m) = Raw Value (dBuV) + Correction Factor (dB/m).
 2. Correction Factor (dB/m) = Antenna Factor (dB/m) + Cable Factor (dB).
 3. The other emission levels were very low against the limit.
 4. Margin value = Emission level – Limit value.
 5. “ * “: Fundamental frequency.

EUT TEST CONDITION		MEASUREMENT DETAIL	
CHANNEL	Channel 6	FREQUENCY RANGE	1 ~ 25GHz
INPUT POWER (SYSTEM)	120Vac, 60 Hz	DETECTOR FUNCTION	Peak (PK) Average (AV)
ENVIRONMENTAL CONDITIONS	24deg. C, 64%RH 1000hPa	TESTED BY	Match Tsui

ANTENNA POLARITY & TEST DISTANCE: HORIZONTAL AT 3 M								
NO.	FREQ. (MHz)	EMISSION LEVEL (dBuV/m)	LIMIT (dBuV/m)	MARGIN (dB)	ANTENNA HEIGHT (m)	TABLE ANGLE (Degree)	RAW VALUE (dBuV)	CORRECTION FACTOR (dB/m)
1	*2437.00	104.05 PK			1.05 H	350	71.45	32.60
2	*2437.00	99.86 AV			1.05 H	350	67.26	32.60
3	4874.00	51.35 PK	74.00	-22.65	1.05 H	10	12.85	38.50
4	4874.00	42.46 AV	54.00	-11.54	1.05 H	10	3.96	38.50
ANTENNA POLARITY & TEST DISTANCE: VERTICAL AT 3 M								
NO.	FREQ. (MHz)	EMISSION LEVEL (dBuV/m)	LIMIT (dBuV/m)	MARGIN (dB)	ANTENNA HEIGHT (m)	TABLE ANGLE (Degree)	RAW VALUE (dBuV)	CORRECTION FACTOR (dB/m)
1	*2437.00	111.66 PK			1.17 V	318	79.06	32.60
2	*2437.00	106.91 AV			1.17 V	318	74.31	32.60
3	4874.00	55.59 PK	74.00	-18.41	1.27 V	93	17.09	38.50
4	4874.00	52.01 AV	54.00	-1.99	1.27 V	93	13.51	38.50
5	7311.00	57.97 PK	74.00	-16.03	1.27 V	163	13.49	44.48
6	7311.00	49.81 AV	54.00	-4.19	1.27 V	163	5.33	44.48

- REMARKS:**
1. Emission level (dBuV/m) = Raw Value (dBuV) + Correction Factor (dB/m).
 2. Correction Factor (dB/m) = Antenna Factor (dB/m) + Cable Factor (dB).
 3. The other emission levels were very low against the limit.
 4. Margin value = Emission level – Limit value.
 5. “ * “: Fundamental frequency.

EUT TEST CONDITION		MEASUREMENT DETAIL	
CHANNEL	Channel 11	FREQUENCY RANGE	1 ~ 25GHz
INPUT POWER (SYSTEM)	120Vac, 60 Hz	DETECTOR FUNCTION	Peak (PK) Average (AV)
ENVIRONMENTAL CONDITIONS	24deg. C, 64%RH 1000hPa	TESTED BY	Match Tsui

ANTENNA POLARITY & TEST DISTANCE: HORIZONTAL AT 3 M								
NO.	FREQ. (MHz)	EMISSION LEVEL (dBuV/m)	LIMIT (dBuV/m)	MARGIN (dB)	ANTENNA HEIGHT (m)	TABLE ANGLE (Degree)	RAW VALUE (dBuV)	CORRECTION FACTOR (dB/m)
1	*2462.00	104.71 PK			1.03 H	350	72.03	32.68
2	*2462.00	100.09 AV			1.03 H	350	67.41	32.68
3	2487.00	58.16 PK	74.00	-15.84	1.03 H	350	25.39	32.77
4	2487.00	47.63 AV	54.00	-6.37	1.03 H	350	14.86	32.77
5	4924.00	50.28 PK	74.00	-23.72	1.01 H	300	11.64	38.64
6	4924.00	43.79 AV	54.00	-10.21	1.01 H	300	5.15	38.64
ANTENNA POLARITY & TEST DISTANCE: VERTICAL AT 3 M								
NO.	FREQ. (MHz)	EMISSION LEVEL (dBuV/m)	LIMIT (dBuV/m)	MARGIN (dB)	ANTENNA HEIGHT (m)	TABLE ANGLE (Degree)	RAW VALUE (dBuV)	CORRECTION FACTOR (dB/m)
1	*2462.00	111.21 PK			1.19 V	184	78.53	32.68
2	*2462.00	106.46 AV			1.19 V	184	73.78	32.68
3	2483.50	61.12 PK	74.00	-12.88	1.18 V	196	28.36	32.76
4	2483.50	51.92 AV	54.00	-2.08	1.18 V	196	19.16	32.76
5	2487.00	60.95 PK	74.00	-13.05	1.21 V	197	28.18	32.77
6	2487.00	52.36 AV	54.00	-1.64	1.21 V	197	19.59	32.77
7	4924.00	56.07 PK	74.00	-17.93	1.26 V	92	17.43	38.64
8	4924.00	52.02 AV	54.00	-1.98	1.26 V	92	13.38	38.64
9	7386.00	60.18 PK	74.00	-13.82	1.06 V	180	15.55	44.63
10	7386.00	51.39 AV	54.00	-2.61	1.06 V	180	6.76	44.63

- REMARKS:**
1. Emission level (dBuV/m) = Raw Value (dBuV) + Correction Factor (dB/m).
 2. Correction Factor (dB/m) = Antenna Factor (dB/m) + Cable Factor (dB).
 3. The other emission levels were very low against the limit.
 4. Margin value = Emission level – Limit value.
 5. “ * “: Fundamental frequency.

802.11g OFDM MODULATION

EUT TEST CONDITION		MEASUREMENT DETAIL	
CHANNEL	Channel 1	FREQUENCY RANGE	1 ~ 25GHz
INPUT POWER (SYSTEM)	120Vac, 60 Hz	DETECTOR FUNCTION	Peak (PK) Average (AV)
ENVIRONMENTAL CONDITIONS	24deg. C, 64%RH 1000hPa	TESTED BY	Match Tsui

ANTENNA POLARITY & TEST DISTANCE: HORIZONTAL AT 3 M								
NO.	FREQ. (MHz)	EMISSION LEVEL (dBuV/m)	LIMIT (dBuV/m)	MARGIN (dB)	ANTENNA HEIGHT (m)	TABLE ANGLE (Degree)	RAW VALUE (dBuV)	CORRECTION FACTOR (dB/m)
1	2390.00	60.75 PK	74.00	-13.25	1.09 H	353	28.31	32.44
2	2390.00	47.51 AV	54.00	-6.49	1.09 H	353	15.07	32.44
3	*2412.00	103.40 PK			1.07 H	350	70.88	32.52
4	*2412.00	93.56 AV			1.07 H	350	61.04	32.52
5	4824.00	49.02 PK	74.00	-24.98	1.00 H	115	10.72	38.30
6	4824.00	36.20 AV	54.00	-17.80	1.00 H	115	-2.10	38.30
ANTENNA POLARITY & TEST DISTANCE: VERTICAL AT 3 M								
NO.	FREQ. (MHz)	EMISSION LEVEL (dBuV/m)	LIMIT (dBuV/m)	MARGIN (dB)	ANTENNA HEIGHT (m)	TABLE ANGLE (Degree)	RAW VALUE (dBuV)	CORRECTION FACTOR (dB/m)
1	2390.00	69.98 PK	74.00	-4.02	1.00 V	322	37.54	32.44
2	2390.00	52.13 AV	54.00	-1.87	1.00 V	322	19.69	32.44
3	*2412.00	112.08 PK			1.18 V	360	79.56	32.52
4	*2412.00	102.30 AV			1.18 V	360	69.78	32.52
5	4874.00	52.80 PK	74.00	-21.20	1.31 V	94	14.30	38.50
6	4874.00	39.18 AV	54.00	-14.82	1.31 V	94	0.68	38.50

- REMARKS:**
1. Emission level (dBuV/m) = Raw Value (dBuV) + Correction Factor (dB/m).
 2. Correction Factor (dB/m) = Antenna Factor (dB/m) + Cable Factor (dB).
 3. The other emission levels were very low against the limit.
 4. Margin value = Emission level – Limit value.
 5. “ * “: Fundamental frequency.

EUT TEST CONDITION		MEASUREMENT DETAIL	
CHANNEL	Channel 6	FREQUENCY RANGE	1 ~ 25GHz
INPUT POWER (SYSTEM)	120Vac, 60 Hz	DETECTOR FUNCTION	Peak (PK) Average (AV)
ENVIRONMENTAL CONDITIONS	24deg. C, 64%RH 1000hPa	TESTED BY	Match Tsui

ANTENNA POLARITY & TEST DISTANCE: HORIZONTAL AT 3 M								
NO.	FREQ. (MHz)	EMISSION LEVEL (dBuV/m)	LIMIT (dBuV/m)	MARGIN (dB)	ANTENNA HEIGHT (m)	TABLE ANGLE (Degree)	RAW VALUE (dBuV)	CORRECTION FACTOR (dB/m)
1	*2437.00	102.43 PK			1.15 H	176	69.83	32.60
2	*2437.00	92.47 AV			1.15 H	176	59.87	32.60
3	4874.00	50.09 PK	74.00	-23.91	1.18 H	360	11.59	38.50
4	4874.00	38.09 AV	54.00	-15.91	1.18 H	360	-0.41	38.50
ANTENNA POLARITY & TEST DISTANCE: VERTICAL AT 3 M								
NO.	FREQ. (MHz)	EMISSION LEVEL (dBuV/m)	LIMIT (dBuV/m)	MARGIN (dB)	ANTENNA HEIGHT (m)	TABLE ANGLE (Degree)	RAW VALUE (dBuV)	CORRECTION FACTOR (dB/m)
1	2384.00	61.53 PK	74.00	-12.47	1.21 V	319	29.11	32.42
2	2384.00	50.03 AV	54.00	-3.97	1.21 V	319	17.61	32.42
3	*2437.00	112.81 PK			1.18 V	317	80.21	32.60
4	*2437.00	102.70 AV			1.18 V	317	70.10	32.60
5	2489.00	63.43 PK	74.00	-10.57	1.17 V	319	30.66	32.77
6	2489.00	51.41 AV	54.00	-2.59	1.17 V	319	18.64	32.77
7	4874.00	57.23 PK	74.00	-16.77	1.11 V	116	18.73	38.50
8	4874.00	39.66 AV	54.00	-14.34	1.11 V	116	1.16	38.50

- REMARKS:**
1. Emission level (dBuV/m) = Raw Value (dBuV) + Correction Factor (dB/m).
 2. Correction Factor (dB/m) = Antenna Factor (dB/m) + Cable Factor (dB).
 3. The other emission levels were very low against the limit.
 4. Margin value = Emission level – Limit value.
 5. “ * “: Fundamental frequency.

EUT TEST CONDITION		MEASUREMENT DETAIL	
CHANNEL	Channel 11	FREQUENCY RANGE	1 ~ 25GHz
INPUT POWER (SYSTEM)	120Vac, 60 Hz	DETECTOR FUNCTION	Peak (PK) Average (AV)
ENVIRONMENTAL CONDITIONS	24deg. C, 64%RH 1000hPa	TESTED BY	Match Tsui

ANTENNA POLARITY & TEST DISTANCE: HORIZONTAL AT 3 M								
NO.	FREQ. (MHz)	EMISSION LEVEL (dBuV/m)	LIMIT (dBuV/m)	MARGIN (dB)	ANTENNA HEIGHT (m)	TABLE ANGLE (Degree)	RAW VALUE (dBuV)	CORRECTION FACTOR (dB/m)
1	*2462.00	103.64 PK			1.32 H	351	70.96	32.68
2	*2462.00	93.30 AV			1.32 H	351	60.62	32.68
3	2483.50	59.52 PK	74.00	-14.48	1.32 H	351	26.76	32.76
4	2483.50	47.59 AV	54.00	-6.41	1.32 H	351	14.83	32.76
5	4924.00	49.38 PK	74.00	-24.62	1.06 H	360	10.74	38.64
6	4924.00	36.65 AV	54.00	-17.35	1.06 H	360	-1.99	38.64
ANTENNA POLARITY & TEST DISTANCE: VERTICAL AT 3 M								
NO.	FREQ. (MHz)	EMISSION LEVEL (dBuV/m)	LIMIT (dBuV/m)	MARGIN (dB)	ANTENNA HEIGHT (m)	TABLE ANGLE (Degree)	RAW VALUE (dBuV)	CORRECTION FACTOR (dB/m)
1	*2462.00	112.04 PK			1.15 V	38	79.36	32.68
2	*2462.00	101.81 AV			1.15 V	38	69.13	32.68
3	2483.50	69.60 PK	74.00	-4.40	1.15 V	316	36.84	32.76
4	2483.50	52.50 AV	54.00	-1.50	1.15 V	316	19.74	32.76
5	4924.00	49.13 PK	74.00	-24.87	1.06 V	360	10.49	38.64
6	4924.00	37.32 AV	54.00	-16.68	1.06 V	360	-1.32	38.64

- REMARKS:**
1. Emission level (dBuV/m) = Raw Value (dBuV) + Correction Factor (dB/m).
 2. Correction Factor (dB/m) = Antenna Factor (dB/m) + Cable Factor (dB).
 3. The other emission levels were very low against the limit.
 4. Margin value = Emission level – Limit value.
 5. “ * “: Fundamental frequency.

DRAFT 802.11n (20MHz) OFDM MODULATION

EUT TEST CONDITION		MEASUREMENT DETAIL	
CHANNEL	Channel 1	FREQUENCY RANGE	1 ~ 25GHz
INPUT POWER (SYSTEM)	120Vac, 60 Hz	DETECTOR FUNCTION	Peak (PK) Average (AV)
ENVIRONMENTAL CONDITIONS	24deg. C, 64%RH 1000hPa	TESTED BY	Match Tsui

ANTENNA POLARITY & TEST DISTANCE: HORIZONTAL AT 3 M								
NO.	FREQ. (MHz)	EMISSION LEVEL (dBuV/m)	LIMIT (dBuV/m)	MARGIN (dB)	ANTENNA HEIGHT (m)	TABLE ANGLE (Degree)	RAW VALUE (dBuV)	CORRECTION FACTOR (dB/m)
1	2390.00	56.81 PK	74.00	-17.19	1.17 H	315	24.37	32.44
2	2390.00	47.05 AV	54.00	-6.95	1.17 H	315	14.61	32.44
3	*2412.00	103.69 PK			1.17 H	315	71.17	32.52
4	*2412.00	93.03 AV			1.17 H	315	60.51	32.52
5	4824.00	48.58 PK	74.00	-25.42	1.00 H	360	10.28	38.30
6	4824.00	37.28 AV	54.00	-16.72	1.00 H	360	-1.02	38.30
ANTENNA POLARITY & TEST DISTANCE: VERTICAL AT 3 M								
NO.	FREQ. (MHz)	EMISSION LEVEL (dBuV/m)	LIMIT (dBuV/m)	MARGIN (dB)	ANTENNA HEIGHT (m)	TABLE ANGLE (Degree)	RAW VALUE (dBuV)	CORRECTION FACTOR (dB/m)
1	2360.00	61.04 PK	74.00	-12.96	1.00 V	179	28.71	32.33
2	2360.00	51.91 AV	54.00	-2.09	1.00 V	179	19.58	32.33
3	2390.00	64.26 PK	74.00	-9.74	1.20 V	11	31.82	32.44
4	2390.00	51.80 AV	54.00	-2.20	1.20 V	11	19.36	32.44
5	*2412.00	113.95 PK			1.20 V	354	81.43	32.52
6	*2412.00	104.08 AV			1.20 V	354	71.56	32.52
7	4824.00	49.42 PK	74.00	-24.58	1.00 V	206	11.12	38.30
8	4824.00	39.07 AV	54.00	-14.93	1.00 V	206	0.77	38.30

- REMARKS:**
1. Emission level (dBuV/m) = Raw Value (dBuV) + Correction Factor (dB/m).
 2. Correction Factor (dB/m) = Antenna Factor (dB/m) + Cable Factor (dB).
 3. The other emission levels were very low against the limit.
 4. Margin value = Emission level – Limit value.
 5. “ * “: Fundamental frequency.

EUT TEST CONDITION		MEASUREMENT DETAIL	
CHANNEL	Channel 6	FREQUENCY RANGE	1 ~ 25GHz
INPUT POWER (SYSTEM)	120Vac, 60 Hz	DETECTOR FUNCTION	Peak (PK) Average (AV)
ENVIRONMENTAL CONDITIONS	24deg. C, 64%RH 1000hPa	TESTED BY	Match Tsui

ANTENNA POLARITY & TEST DISTANCE: HORIZONTAL AT 3 M								
NO.	FREQ. (MHz)	EMISSION LEVEL (dBuV/m)	LIMIT (dBuV/m)	MARGIN (dB)	ANTENNA HEIGHT (m)	TABLE ANGLE (Degree)	RAW VALUE (dBuV)	CORRECTION FACTOR (dB/m)
1	*2437.00	103.55 PK			1.40 H	129	70.95	32.60
2	*2437.00	93.48 AV			1.40 H	129	60.88	32.60
3	4874.00	49.73 PK	74.00	-24.27	1.00 H	360	11.23	38.50
4	4874.00	36.59 AV	54.00	-17.41	1.00 H	360	-1.91	38.50
ANTENNA POLARITY & TEST DISTANCE: VERTICAL AT 3 M								
NO.	FREQ. (MHz)	EMISSION LEVEL (dBuV/m)	LIMIT (dBuV/m)	MARGIN (dB)	ANTENNA HEIGHT (m)	TABLE ANGLE (Degree)	RAW VALUE (dBuV)	CORRECTION FACTOR (dB/m)
1	2360.00	60.51 PK	74.00	-13.49	1.00 V	176	28.18	32.33
2	2360.00	50.85 AV	54.00	-3.15	1.00 V	176	18.52	32.33
3	*2437.00	113.54 PK			1.19 V	13	80.94	32.60
4	*2437.00	103.70 AV			1.19 V	13	71.10	32.60
5	4874.00	48.91 PK	74.00	-25.09	1.00 V	325	10.41	38.50
6	4874.00	37.59 AV	54.00	-16.41	1.00 V	325	-0.91	38.50

- REMARKS:**
1. Emission level (dBuV/m) = Raw Value (dBuV) + Correction Factor (dB/m).
 2. Correction Factor (dB/m) = Antenna Factor (dB/m) + Cable Factor (dB).
 3. The other emission levels were very low against the limit.
 4. Margin value = Emission level – Limit value.
 5. “ * ”: Fundamental frequency.

EUT TEST CONDITION		MEASUREMENT DETAIL	
CHANNEL	Channel 11	FREQUENCY RANGE	1 ~ 25GHz
INPUT POWER (SYSTEM)	120Vac, 60 Hz	DETECTOR FUNCTION	Peak (PK) Average (AV)
ENVIRONMENTAL CONDITIONS	24deg. C, 64%RH 1000hPa	TESTED BY	Match Tsui

ANTENNA POLARITY & TEST DISTANCE: HORIZONTAL AT 3 M								
NO.	FREQ. (MHz)	EMISSION LEVEL (dBuV/m)	LIMIT (dBuV/m)	MARGIN (dB)	ANTENNA HEIGHT (m)	TABLE ANGLE (Degree)	RAW VALUE (dBuV)	CORRECTION FACTOR (dB/m)
1	*2462.00	104.54 PK			1.10 H	152	71.86	32.68
2	*2462.00	94.36 AV			1.10 H	152	61.68	32.68
3	2483.50	60.62 PK	74.00	-13.38	1.10 H	152	27.86	32.76
4	2483.50	47.65 AV	54.00	-6.35	1.10 H	152	14.89	32.76
5	4924.00	49.94 PK	74.00	-24.06	1.00 H	360	11.30	38.64
6	4924.00	36.68 AV	54.00	-17.32	1.00 H	360	-1.96	38.64
ANTENNA POLARITY & TEST DISTANCE: VERTICAL AT 3 M								
NO.	FREQ. (MHz)	EMISSION LEVEL (dBuV/m)	LIMIT (dBuV/m)	MARGIN (dB)	ANTENNA HEIGHT (m)	TABLE ANGLE (Degree)	RAW VALUE (dBuV)	CORRECTION FACTOR (dB/m)
1	2360.00	62.60 PK	74.00	-11.40	1.00 V	340	30.27	32.33
2	2360.00	52.02 AV	54.00	-1.98	1.00 V	340	19.69	32.33
3	*2462.00	115.24 PK			1.20 V	171	82.56	32.68
4	*2462.00	104.01 AV			1.20 V	171	71.33	32.68
5	2483.50	68.95 PK	74.00	-5.05	1.21 V	181	36.19	32.76
6	2483.50	52.51 AV	54.00	-1.49	1.21 V	181	19.75	32.76
7	4924.00	49.94 PK	74.00	-24.06	1.20 V	0	11.30	38.64
8	4924.00	37.22 AV	54.00	-16.78	1.20 V	0	-1.42	38.64

- REMARKS:**
1. Emission level (dBuV/m) = Raw Value (dBuV) + Correction Factor (dB/m).
 2. Correction Factor (dB/m) = Antenna Factor (dB/m) + Cable Factor (dB).
 3. The other emission levels were very low against the limit.
 4. Margin value = Emission level – Limit value.
 5. “ * “: Fundamental frequency.

DRAFT 802.11n (40MHz) OFDM MODULATION

EUT TEST CONDITION		MEASUREMENT DETAIL	
CHANNEL	Channel 1	FREQUENCY RANGE	1 ~ 25GHz
INPUT POWER (SYSTEM)	120Vac, 60 Hz	DETECTOR FUNCTION	Peak (PK) Average (AV)
ENVIRONMENTAL CONDITIONS	24deg. C, 64%RH 1000hPa	TESTED BY	Match Tsui

ANTENNA POLARITY & TEST DISTANCE: HORIZONTAL AT 3 M								
NO.	FREQ. (MHz)	EMISSION LEVEL (dBuV/m)	LIMIT (dBuV/m)	MARGIN (dB)	ANTENNA HEIGHT (m)	TABLE ANGLE (Degree)	RAW VALUE (dBuV)	CORRECTION FACTOR (dB/m)
1	2390.00	55.94 PK	74.00	-18.06	1.37 H	125	23.50	32.44
2	2390.00	46.81 AV	54.00	-7.19	1.37 H	125	14.37	32.44
3	*2422.00	97.55 PK			1.37 H	125	65.00	32.55
4	*2422.00	86.84 AV			1.37 H	125	54.29	32.55
5	4844.00	49.27 PK	74.00	-24.73	1.00 H	350	10.90	38.38
6	4844.00	35.78 AV	54.00	-18.22	1.00 H	350	-2.59	38.38
ANTENNA POLARITY & TEST DISTANCE: VERTICAL AT 3 M								
NO.	FREQ. (MHz)	EMISSION LEVEL (dBuV/m)	LIMIT (dBuV/m)	MARGIN (dB)	ANTENNA HEIGHT (m)	TABLE ANGLE (Degree)	RAW VALUE (dBuV)	CORRECTION FACTOR (dB/m)
1	2360.00	59.90 PK	74.00	-14.10	1.00 V	178	27.57	32.33
2	2360.00	50.61 AV	54.00	-3.39	1.00 V	178	18.28	32.33
3	2390.00	64.26 PK	74.00	-9.74	1.27 V	162	31.82	32.44
4	2390.00	52.63 AV	54.00	-1.37	1.27 V	162	20.19	32.44
5	*2422.00	107.80 PK			1.22 V	182	75.25	32.55
6	*2422.00	97.20 AV			1.22 V	182	64.65	32.55
7	4844.00	49.31 PK	74.00	-24.69	1.16 V	0	10.94	38.38
8	4844.00	36.10 AV	54.00	-17.90	1.16 V	0	-2.27	38.38

- REMARKS:**
1. Emission level (dBuV/m) = Raw Value (dBuV) + Correction Factor (dB/m).
 2. Correction Factor (dB/m) = Antenna Factor (dB/m) + Cable Factor (dB).
 3. The other emission levels were very low against the limit.
 4. Margin value = Emission level – Limit value.
 5. “ * “: Fundamental frequency.

EUT TEST CONDITION		MEASUREMENT DETAIL	
CHANNEL	Channel 4	FREQUENCY RANGE	1 ~ 25GHz
INPUT POWER (SYSTEM)	120Vac, 60 Hz	DETECTOR FUNCTION	Peak (PK) Average (AV)
ENVIRONMENTAL CONDITIONS	24deg. C, 64%RH 1000hPa	TESTED BY	Match Tsui

ANTENNA POLARITY & TEST DISTANCE: HORIZONTAL AT 3 M								
NO.	FREQ. (MHz)	EMISSION LEVEL (dBuV/m)	LIMIT (dBuV/m)	MARGIN (dB)	ANTENNA HEIGHT (m)	TABLE ANGLE (Degree)	RAW VALUE (dBuV)	CORRECTION FACTOR (dB/m)
1	*2437.00	98.43 PK			1.22 H	360	65.83	32.60
2	*2437.00	87.23 AV			1.22 H	360	54.63	32.60
3	4874.00	48.97 PK	74.00	-25.03	1.10 H	10	10.47	38.50
4	4874.00	36.13 AV	54.00	-17.87	1.10 H	10	-2.37	38.50
ANTENNA POLARITY & TEST DISTANCE: VERTICAL AT 3 M								
NO.	FREQ. (MHz)	EMISSION LEVEL (dBuV/m)	LIMIT (dBuV/m)	MARGIN (dB)	ANTENNA HEIGHT (m)	TABLE ANGLE (Degree)	RAW VALUE (dBuV)	CORRECTION FACTOR (dB/m)
1	2360.00	59.91 PK	74.00	-14.09	1.21 V	103	27.58	32.33
2	2360.00	49.41 AV	54.00	-4.59	1.21 V	103	17.08	32.33
3	*2437.00	107.39 PK			1.24 V	181	74.79	32.60
4	*2437.00	96.91 AV			1.24 V	181	64.31	32.60
5	4874.00	48.98 PK	74.00	-25.02	1.20 V	360	10.48	38.50
6	4874.00	37.04 AV	54.00	-16.96	1.20 V	360	-1.46	38.50

- REMARKS:**
1. Emission level (dBuV/m) = Raw Value (dBuV) + Correction Factor (dB/m).
 2. Correction Factor (dB/m) = Antenna Factor (dB/m) + Cable Factor (dB).
 3. The other emission levels were very low against the limit.
 4. Margin value = Emission level – Limit value.
 5. “ * ”: Fundamental frequency.

EUT TEST CONDITION		MEASUREMENT DETAIL	
CHANNEL	Channel 7	FREQUENCY RANGE	1 ~ 25GHz
INPUT POWER (SYSTEM)	120Vac, 60 Hz	DETECTOR FUNCTION	Peak (PK) Average (AV)
ENVIRONMENTAL CONDITIONS	24deg. C, 64%RH 1000hPa	TESTED BY	Match Tsui

ANTENNA POLARITY & TEST DISTANCE: HORIZONTAL AT 3 M								
NO.	FREQ. (MHz)	EMISSION LEVEL (dBuV/m)	LIMIT (dBuV/m)	MARGIN (dB)	ANTENNA HEIGHT (m)	TABLE ANGLE (Degree)	RAW VALUE (dBuV)	CORRECTION FACTOR (dB/m)
1	*2452.00	97.64 PK			1.13 H	161	64.99	32.65
2	*2452.00	86.72 AV			1.13 H	161	54.07	32.65
3	2483.50	56.41 PK	74.00	-17.59	1.13 H	161	23.65	32.76
4	2483.50	46.65 AV	54.00	-7.35	1.13 H	161	13.89	32.76
5	4904.00	49.14 PK	74.00	-24.86	1.10 H	10	10.53	38.61
6	4904.00	36.14 AV	54.00	-17.86	1.10 H	10	-2.47	38.61
ANTENNA POLARITY & TEST DISTANCE: VERTICAL AT 3 M								
NO.	FREQ. (MHz)	EMISSION LEVEL (dBuV/m)	LIMIT (dBuV/m)	MARGIN (dB)	ANTENNA HEIGHT (m)	TABLE ANGLE (Degree)	RAW VALUE (dBuV)	CORRECTION FACTOR (dB/m)
1	2360.00	59.55 PK	74.00	-14.45	1.00 V	180	27.22	32.33
2	2360.00	49.75 AV	54.00	-4.25	1.00 V	180	17.42	32.33
3	*2452.00	107.24 PK			1.22 V	183	74.59	32.65
4	*2452.00	96.55 AV			1.22 V	183	63.90	32.65
5	2483.50	67.18 PK	74.00	-6.82	1.19 V	172	34.42	32.76
6	2483.50	52.99 AV	54.00	-1.01	1.19 V	172	20.23	32.76
7	4904.00	49.89 PK	74.00	-24.11	1.22 V	360	11.28	38.61
8	4904.00	37.02 AV	54.00	-16.98	1.22 V	360	-1.59	38.61

- REMARKS:**
1. Emission level (dBuV/m) = Raw Value (dBuV) + Correction Factor (dB/m).
 2. Correction Factor (dB/m) = Antenna Factor (dB/m) + Cable Factor (dB).
 3. The other emission levels were very low against the limit.
 4. Margin value = Emission level – Limit value.
 5. “ * “: Fundamental frequency.

BELOW 1GHz WORST-CASE DATA : DRAFT 802.11n (20MHz) OFDM MODULATION

EUT TEST CONDITION		MEASUREMENT DETAIL	
CHANNEL	Channel 11	FREQUENCY RANGE	Below 1000MHz
INPUT POWER (SYSTEM)	120Vac, 60 Hz	DETECTOR FUNCTION	Quasi-Peak
ENVIRONMENTAL CONDITIONS	24deg. C, 64%RH 999hPa	TESTED BY	Match Tsui
TEST MODE	A		

ANTENNA POLARITY & TEST DISTANCE: HORIZONTAL AT 3 M								
NO.	FREQ. (MHz)	EMISSION LEVEL (dBuV/m)	LIMIT (dBuV/m)	MARGIN (dB)	ANTENNA HEIGHT (m)	TABLE ANGLE (Degree)	RAW VALUE (dBuV)	CORRECTION FACTOR (dB/m)
1	101.84	33.91 QP	43.50	-9.59	2.00 H	301	21.95	11.96
2	249.60	41.28 QP	46.00	-4.72	1.00 H	79	26.88	14.40
3	313.77	38.45 QP	46.00	-7.55	1.25 H	55	23.40	15.05
4	383.76	38.98 QP	46.00	-7.02	2.00 H	301	20.77	18.22
5	500.42	37.02 QP	46.00	-8.98	1.00 H	34	15.55	21.48
6	640.41	37.21 QP	46.00	-8.79	1.25 H	121	12.41	24.80
7	751.23	40.30 QP	46.00	-5.70	1.00 H	340	13.24	27.06
8	768.73	40.14 QP	46.00	-5.86	1.00 H	106	12.91	27.23
9	897.05	44.97 QP	46.00	-1.03	1.00 H	328	15.14	29.83
ANTENNA POLARITY & TEST DISTANCE: VERTICAL AT 3 M								
NO.	FREQ. (MHz)	EMISSION LEVEL (dBuV/m)	LIMIT (dBuV/m)	MARGIN (dB)	ANTENNA HEIGHT (m)	TABLE ANGLE (Degree)	RAW VALUE (dBuV)	CORRECTION FACTOR (dB/m)
1	55.18	34.75 QP	40.00	-5.25	1.25 V	175	21.41	13.34
2	68.79	35.82 QP	40.00	-4.18	1.00 V	10	22.24	13.58
3	125.17	35.19 QP	43.50	-8.31	1.00 V	208	22.99	12.20
4	249.60	43.94 QP	46.00	-2.06	1.00 V	10	29.54	14.40
5	383.76	41.57 QP	46.00	-4.43	1.50 V	271	23.35	18.22
6	500.42	38.85 QP	46.00	-7.15	2.00 V	229	17.37	21.48
7	640.41	36.88 QP	46.00	-9.12	1.00 V	259	12.08	24.80
8	751.23	37.69 QP	46.00	-8.31	1.00 V	10	10.63	27.06
9	897.05	44.77 QP	46.00	-1.23	1.00 V	16	14.94	29.83

- REMARKS:**
1. Emission level (dBuV/m) = Raw Value (dBuV) + Correction Factor (dB/m).
 2. Correction Factor (dB/m) = Antenna Factor (dB/m) + Cable Factor (dB).
 3. The other emission levels were very low against the limit.
 4. Margin value = Emission level – Limit value.

EUT TEST CONDITION		MEASUREMENT DETAIL	
CHANNEL	Channel 11	FREQUENCY RANGE	Below 1000MHz
INPUT POWER (SYSTEM)	120Vac, 60 Hz	DETECTOR FUNCTION	Quasi-Peak
ENVIRONMENTAL CONDITIONS	24deg. C, 64%RH 999hPa	TESTED BY	Match Tsui
TEST MODE	B		

ANTENNA POLARITY & TEST DISTANCE: HORIZONTAL AT 3 M								
NO.	FREQ. (MHz)	EMISSION LEVEL (dBuV/m)	LIMIT (dBuV/m)	MARGIN (dB)	ANTENNA HEIGHT (m)	TABLE ANGLE (Degree)	RAW VALUE (dBuV)	CORRECTION FACTOR (dB/m)
1	249.60	43.97 QP	46.00	-2.03	1.50 H	310	29.57	14.40
2	290.43	38.19 QP	46.00	-7.81	1.00 H	10	23.78	14.41
3	383.76	36.69 QP	46.00	-9.31	1.00 H	223	18.47	18.22
4	640.41	42.73 QP	46.00	-3.27	1.25 H	313	17.93	24.80
5	768.73	43.62 QP	46.00	-2.38	1.00 H	343	16.39	27.23
6	897.05	44.37 QP	46.00	-1.63	1.50 H	76	14.54	29.83
ANTENNA POLARITY & TEST DISTANCE: VERTICAL AT 3 M								
NO.	FREQ. (MHz)	EMISSION LEVEL (dBuV/m)	LIMIT (dBuV/m)	MARGIN (dB)	ANTENNA HEIGHT (m)	TABLE ANGLE (Degree)	RAW VALUE (dBuV)	CORRECTION FACTOR (dB/m)
1	127.11	35.43 QP	43.50	-8.07	1.25 V	22	23.07	12.36
2	249.60	41.11 QP	46.00	-4.89	1.00 V	106	26.71	14.40
3	383.76	37.41 QP	46.00	-8.59	1.25 V	46	19.20	18.22
4	640.41	40.22 QP	46.00	-5.78	2.00 V	262	15.42	24.80
5	768.73	38.01 QP	46.00	-7.99	1.25 V	325	10.77	27.23
6	897.05	42.51 QP	46.00	-3.49	2.00 V	19	12.68	29.83

- REMARKS:**
1. Emission level (dBuV/m) = Raw Value (dBuV) + Correction Factor (dB/m).
 2. Correction Factor (dB/m) = Antenna Factor (dB/m) + Cable Factor (dB).
 3. The other emission levels were very low against the limit.
 4. Margin value = Emission level – Limit value.

4.2 CONDUCTED EMISSION MEASUREMENT

4.2.1 LIMITS OF CONDUCTED EMISSION MEASUREMENT

FREQUENCY OF EMISSION (MHz)	CONDUCTED LIMIT (dB μ V)	
	Quasi-peak	Average
0.15 ~ 0.5	66 to 56	56 to 46
0.5 ~ 5	56	46
5 ~ 30	60	50

- NOTE:** 1. The lower limit shall apply at the transition frequencies.
2. The limit decreases in line with the logarithm of the frequency in the range of 0.15 to 0.50MHz.
3. All emanations from a class A/B digital device or system, including any network of conductors and apparatus connected thereto, shall not exceed the level of field strengths specified above.

4.2.2 TEST INSTRUMENTS

DESCRIPTION & MANUFACTURER	MODEL NO.	SERIAL NO.	DATE OF CALIBRATION	DUE DATE OF CALIBRATION
Test Receiver ROHDE & SCHWARZ	ESCS30	100291	Nov. 22, 2007	Nov. 21, 2008
RF signal cable Woken	5D-FB	Cable-HYC01-01	Jan. 04, 2008	Jan. 03, 2009
LISN ROHDE & SCHWARZ	ESH3-Z5	100312	Jun. 13, 2008	Jun. 12, 2009
V-LISN SCHWARZBECK	NNBL 8226-2	8226-142	Jun. 10, 2008	Jun. 09, 2009
Software ADT	ADT_Cond_V3	NA	NA	NA

- NOTE:** 1. The calibration interval of the above test instruments is 12 months and the calibrations are traceable to NML/ROC and NIST/USA.
2. The test was performed in HwaYa Shielded Room 1.
3. The VCCI Site Registration No. is C-2040.

4.2.3 TEST PROCEDURES

- a. The EUT was placed 0.4 meters from the conducting wall of the shielded room with EUT being connected to the power mains through a line impedance stabilization network (LISN). Other support units were connected to the power mains through another LISN. The two LISNs provide 50 ohm/ 50uH of coupling impedance for the measuring instrument.
- b. Both lines of the power mains connected to the EUT were checked for maximum conducted interference.
- c. The frequency range from 150kHz to 30MHz was searched. Emission levels under (Limit - 20dB) was not recorded.

NOTE: All modes of operation were investigated and the worst-case emissions are reported.

4.2.4 DEVIATION FROM TEST STANDARD

No deviation.

4.2.5 TEST SETUP

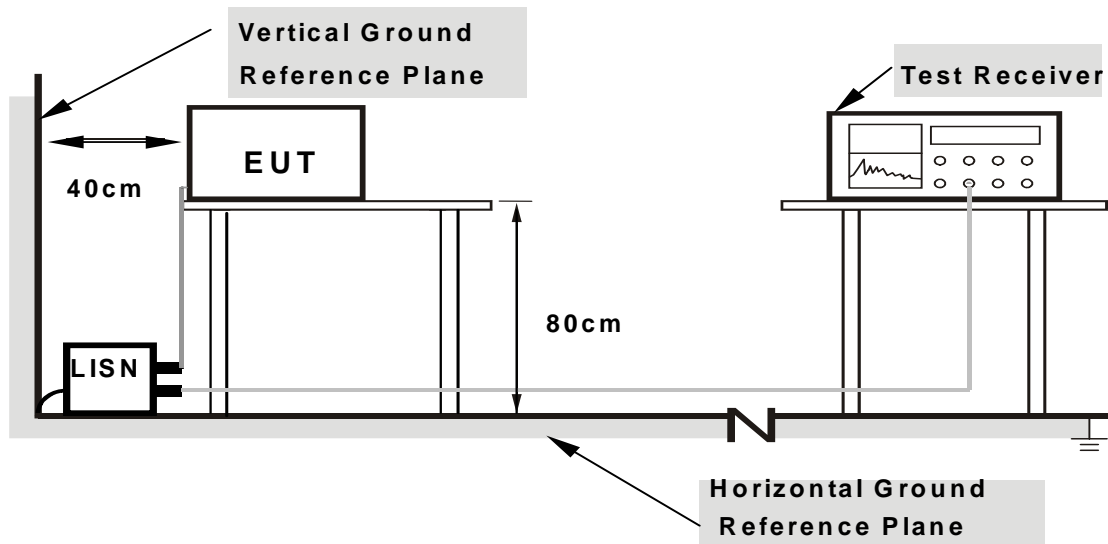

- Note:**
1. Support units were connected to second LISN.
 2. Both of LISNs (AMN) are 80 cm from EUT and at least 80 from other units and other metal planes

For the actual test configuration, please refer to the attached file (Test Setup Photo).

4.2.6 EUT OPERATING CONDITIONS

Same as 4.1.6.

4.2.7 TEST RESULTS

CONDUCTED WORST-CASE DATA : DRAFT 802.11n (20MHz) OFDM MODULATION

EUT TEST CONDITION		MEASUREMENT DETAIL	
CHANNEL	Channel 11	PHASE	Line 1
MODULATION TYPE	OFDM	INPUT POWER	120Vac, 60Hz
TRANSFER RATE	7.2Mbps	6dB BANDWIDTH	9kHz
ENVIRONMENTAL CONDITIONS	23deg. C, 66%RH, 1010hPa	TESTED BY	Mark Liao
TEST MODE	A		

No	Freq. [MHz]	Corr. Factor (dB)	Reading Value [dB (uV)]		Emission Level [dB (uV)]		Limit [dB (uV)]		Margin (dB)	
			Q.P.	AV.	Q.P.	AV.	Q.P.	AV.	Q.P.	AV.
1	0.197	0.06	50.30	-	50.36	-	63.75	53.75	-13.39	-
2	0.263	0.06	46.79	-	46.85	-	61.33	51.33	-14.47	-
3	0.530	0.07	43.92	-	43.99	-	56.00	46.00	-12.01	-
4	0.769	0.08	43.36	-	43.44	-	56.00	46.00	-12.56	-
5	3.499	0.25	41.23	-	41.48	-	56.00	46.00	-14.52	-
6	18.242	1.59	42.08	-	43.67	-	60.00	50.00	-16.33	-

- REMARKS:**
1. Q.P. and AV. are abbreviations of quasi-peak and average individually.
 2. "-": The Quasi-peak reading value also meets average limit and measurement with the average detector is unnecessary.
 3. The emission levels of other frequencies were very low against the limit.
 4. Margin value = Emission level - Limit value
 5. Correction factor = Insertion loss + Cable loss
 6. Emission Level = Correction Factor + Reading Value.

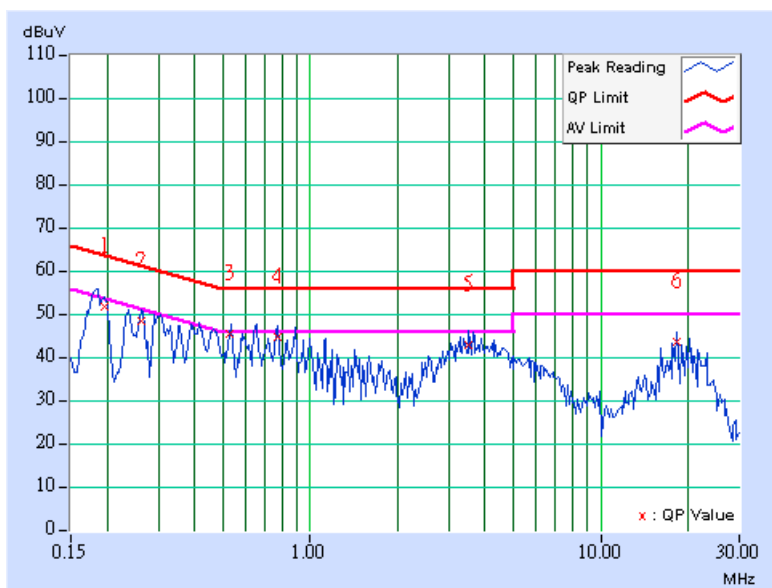

EUT TEST CONDITION		MEASUREMENT DETAIL	
CHANNEL	Channel 11	PHASE	Line 2
MODULATION TYPE	OFDM	INPUT POWER	120Vac, 60Hz
TRANSFER RATE	7.2Mbps	6dB BANDWIDTH	9kHz
ENVIRONMENTAL CONDITIONS	20deg. C, 60%RH, 1010hPa	TESTED BY	Mark Liao
TEST MODE	A		

No	Freq. [MHz]	Corr. Factor (dB)	Reading Value [dB (uV)]		Emission Level [dB (uV)]		Limit [dB (uV)]		Margin (dB)	
			Q.P.	AV.	Q.P.	AV.	Q.P.	AV.	Q.P.	AV.
1	0.193	0.08	50.68	-	50.76	-	63.91	53.91	-13.15	-
2	0.262	0.08	47.94	-	48.02	-	61.37	51.37	-13.35	-
3	0.462	0.09	42.27	-	42.36	-	56.65	46.65	-14.29	-
4	0.887	0.11	44.02	-	44.13	-	56.00	46.00	-11.87	-
5	3.846	0.29	40.95	-	41.24	-	56.00	46.00	-14.76	-
6	18.242	1.09	42.34	-	43.43	-	60.00	50.00	-16.57	-

- REMARKS:**
1. Q.P. and AV. are abbreviations of quasi-peak and average individually.
 2. "-": The Quasi-peak reading value also meets average limit and measurement with the average detector is unnecessary.
 3. The emission levels of other frequencies were very low against the limit.
 4. Margin value = Emission level - Limit value
 5. Correction factor = Insertion loss + Cable loss
 6. Emission Level = Correction Factor + Reading Value.

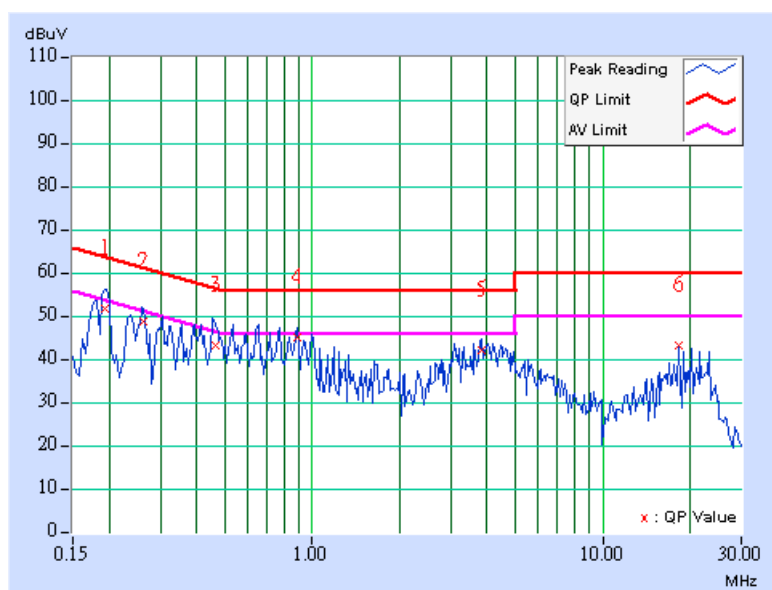

EUT TEST CONDITION		MEASUREMENT DETAIL	
CHANNEL	Channel 11	PHASE	Line 1
MODULATION TYPE	OFDM	INPUT POWER	120Vac, 60Hz
TRANSFER RATE	7.2Mbps	6dB BANDWIDTH	9kHz
ENVIRONMENTAL CONDITIONS	23deg. C, 66%RH, 1010hPa	TESTED BY	Mark Liao
TEST MODE	B		

No	Freq. [MHz]	Corr.	Reading Value		Emission Level		Limit		Margin	
		Factor (dB)	[dB (uV)]		[dB (uV)]		[dB (uV)]		(dB)	
			Q.P.	AV.	Q.P.	AV.	Q.P.	AV.	Q.P.	AV.
1	0.194	0.06	48.94	-	49.00	-	63.84	53.84	-14.84	-
2	0.263	0.06	47.55	-	47.61	-	61.33	51.33	-13.71	-
3	0.470	0.07	42.20	-	42.27	-	56.51	46.51	-14.24	-
4	0.771	0.08	42.15	-	42.23	-	56.00	46.00	-13.77	-
5	3.887	0.29	41.14	-	41.43	-	56.00	46.00	-14.57	-
6	18.242	1.59	38.83	-	40.42	-	60.00	50.00	-19.58	-

- REMARKS:**
1. Q.P. and AV. are abbreviations of quasi-peak and average individually.
 2. "-": The Quasi-peak reading value also meets average limit and measurement with the average detector is unnecessary.
 3. The emission levels of other frequencies were very low against the limit.
 4. Margin value = Emission level - Limit value
 5. Correction factor = Insertion loss + Cable loss
 6. Emission Level = Correction Factor + Reading Value.

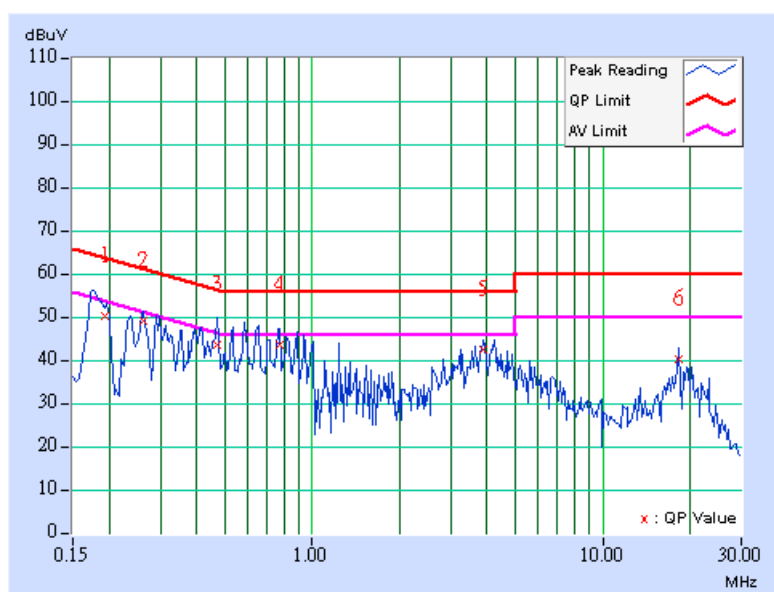

EUT TEST CONDITION		MEASUREMENT DETAIL	
CHANNEL	Channel 11	PHASE	Line 2
MODULATION TYPE	OFDM	INPUT POWER	120Vac, 60Hz
TRANSFER RATE	7.2Mbps	6dB BANDWIDTH	9kHz
ENVIRONMENTAL CONDITIONS	20deg. C, 60%RH, 1010hPa	TESTED BY	Mark Liao
TEST MODE	B		

No	Freq.	Corr. Factor	Reading Value		Emission Level		Limit		Margin	
			[dB (uV)]	[dB (uV)]	[dB (uV)]	[dB (uV)]	[dB (uV)]	[dB (uV)]	(dB)	(dB)
	[MHz]	(dB)	Q.P.	AV.	Q.P.	AV.	Q.P.	AV.	Q.P.	AV.
1	0.195	0.08	51.86	-	51.94	-	63.82	53.82	-11.88	-
2	0.297	0.08	44.10	-	44.18	-	60.32	50.32	-16.14	-
3	0.404	0.09	41.33	-	41.42	-	57.77	47.77	-16.35	-
4	0.888	0.11	42.43	-	42.54	-	56.00	46.00	-13.46	-
5	3.711	0.28	40.23	-	40.51	-	56.00	46.00	-15.49	-
6	18.242	1.09	38.81	-	39.90	-	60.00	50.00	-20.10	-

- REMARKS:**
1. Q.P. and AV. are abbreviations of quasi-peak and average individually.
 2. "-": The Quasi-peak reading value also meets average limit and measurement with the average detector is unnecessary.
 3. The emission levels of other frequencies were very low against the limit.
 4. Margin value = Emission level - Limit value
 5. Correction factor = Insertion loss + Cable loss
 6. Emission Level = Correction Factor + Reading Value.

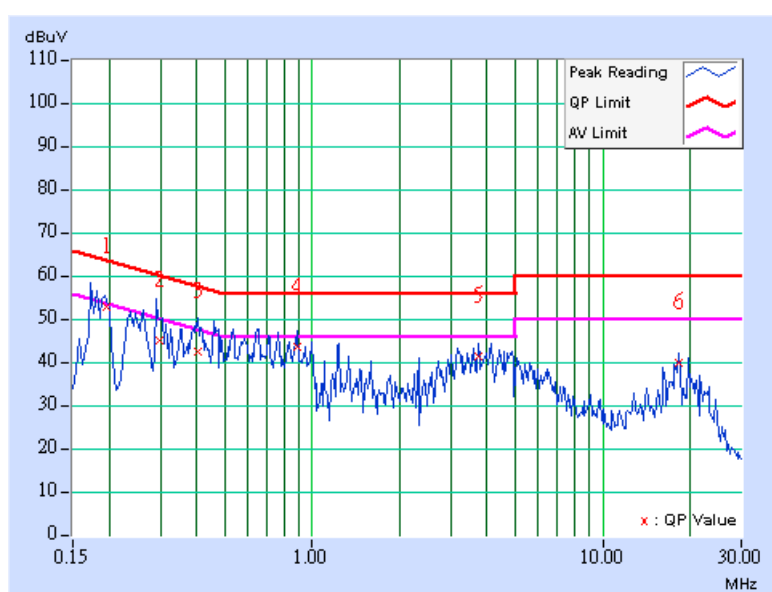



4.3 6dB BANDWIDTH MEASUREMENT

4.3.1 LIMITS OF 6dB BANDWIDTH MEASUREMENT

The minimum of 6dB Bandwidth Measurement is 0.5 MHz.

4.3.2 TEST INSTRUMENTS

DESCRIPTION & MANUFACTURER	MODEL NO.	SERIAL NO.	DATE OF CALIBRATION	CALIBRATED UNTIL
R&S SPECTRUM ANALYZER	FSP40	100041	Apr. 22, 2008	Apr. 21, 2009

NOTE: The calibration interval of the above test instruments is 12 months and the calibrations are traceable to NML/ROC and NIST/USA.

4.3.3 TEST PROCEDURE

The transmitter output was connected to the spectrum analyzer through an attenuator. The bandwidth of the fundamental frequency was measured by spectrum analyzer with 100kHz RBW and 300kHz VBW. The 6dB bandwidth is defined as the total spectrum the power of which is higher than peak power minus 6dB.

4.3.4 DEVIATION FROM TEST STANDARD

No deviation.

4.3.5 TEST SETUP

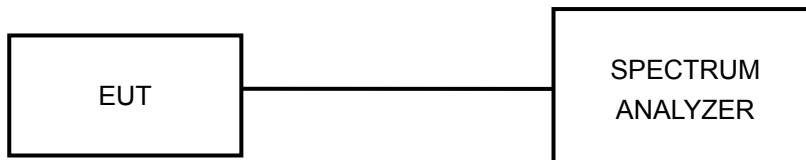

4.3.6 EUT OPERATING CONDITIONS

The software provided by client to enable the EUT under transmission condition continuously at lowest, middle and highest channel frequencies individually.

4.3.7 TEST RESULTS

802.11b DSSS MODULATION

MODULATION TYPE	DBPSK	TRANSFER RATE	1.0Mbps
INPUT POWER	120Vac, 60Hz	ENVIRONMENTAL CONDITIONS	25 deg.C, 63 %RH, 991hPa
TESTED BY	Match Tsui		

CHANNEL	CHANNEL FREQUENCY (MHz)	6dB BANDWIDTH (MHz)	MINIMUM LIMIT (MHz)	PASS / FAIL
1	2412	12.16	0.5	PASS
6	2437	12.14	0.5	PASS
11	2462	12.15	0.5	PASS

CH 1

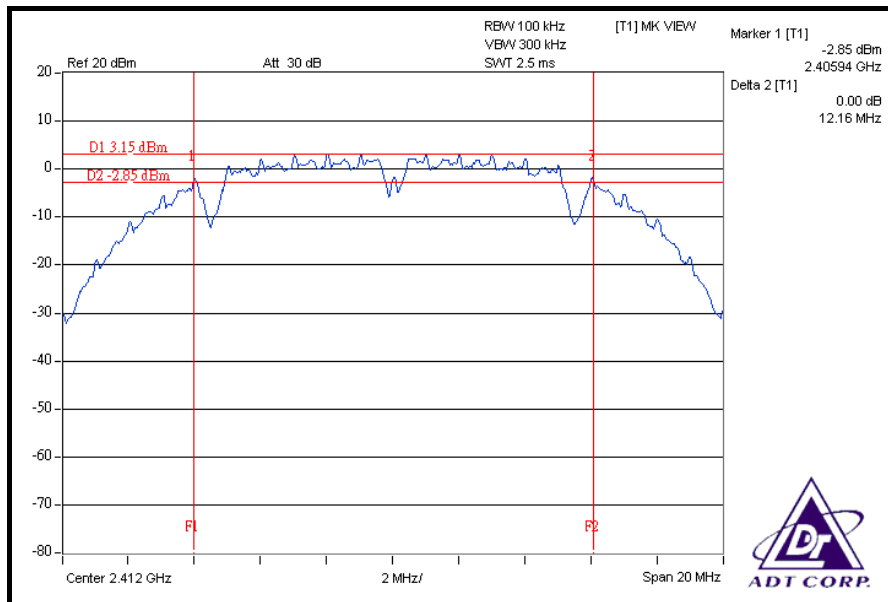

CH 6

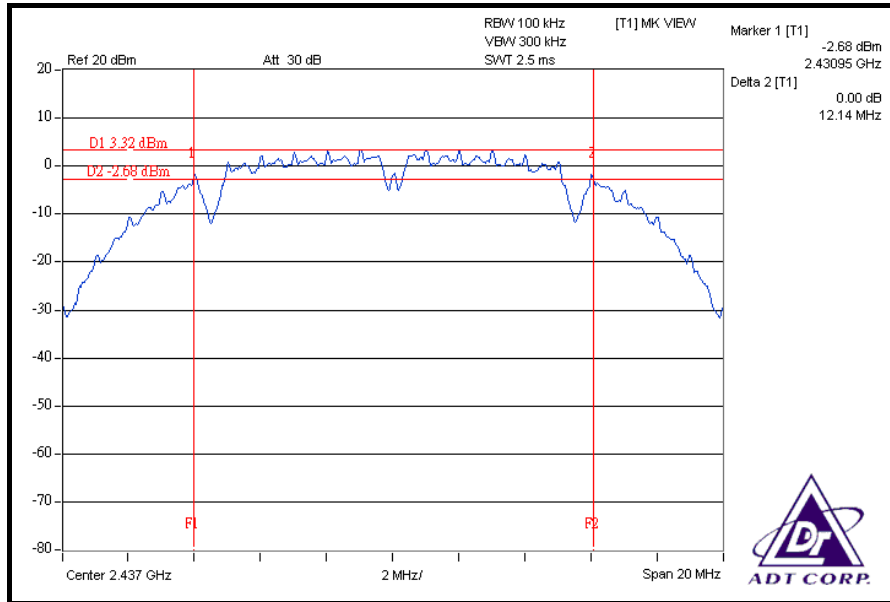

CH 11

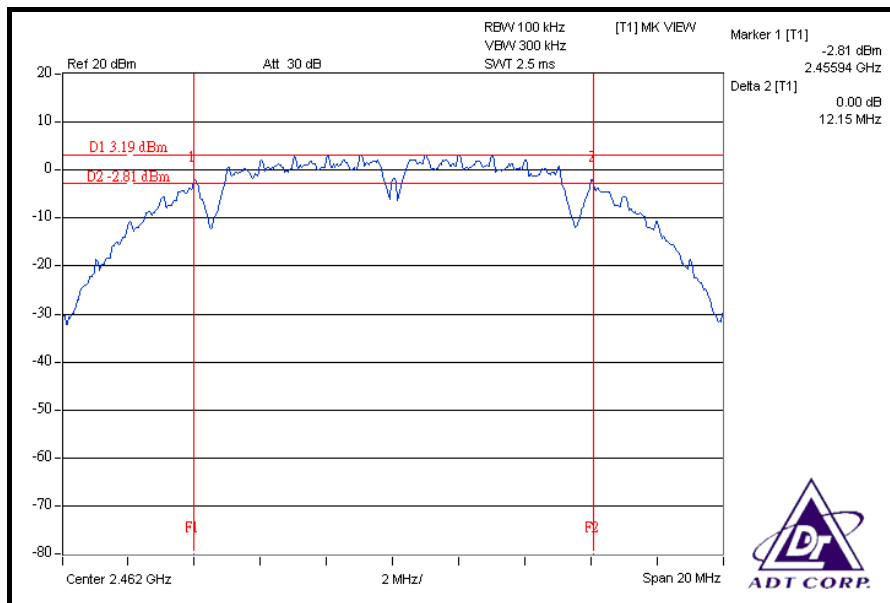



802.11g OFDM MODULATION

MODULATION TYPE	BPSK	TRANSFER RATE	6.0Mbps
INPUT POWER	120Vac, 60Hz	ENVIRONMENTAL CONDITIONS	25 deg.C, 63 %RH, 991hPa
TESTED BY	Match Tsui		

CHANNEL	CHANNEL FREQUENCY (MHz)	6dB BANDWIDTH (MHz)	MINIMUM LIMIT (MHz)	PASS / FAIL
1	2412	16.56	0.5	PASS
6	2437	16.51	0.5	PASS
11	2462	16.52	0.5	PASS

CH 1

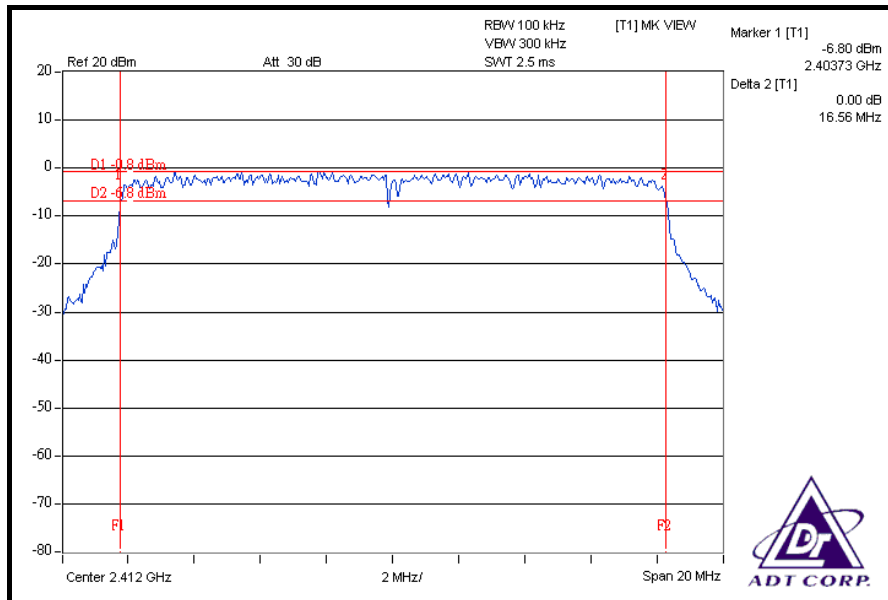



DRAFT 802.11n (20MHz) OFDM MODULATION

MODULATION TYPE	BPSK	TRANSFER RATE	7.2Mbps
INPUT POWER	120Vac, 60Hz	ENVIRONMENTAL CONDITIONS	25 deg.C, 63 %RH, 991hPa
TESTED BY	Match Tsui		

CHANNEL	CHANNEL FREQUENCY (MHz)	6dB BANDWIDTH (MHz)		MINIMUM LIMIT (MHz)	PASS / FAIL
		CHAIN 0	CHAIN 1		
1	2412	17.63	17.23	0.5	PASS
6	2437	17.61	17.59	0.5	PASS
11	2462	17.64	17.35	0.5	PASS

FOR CHAIN 0: CH 1

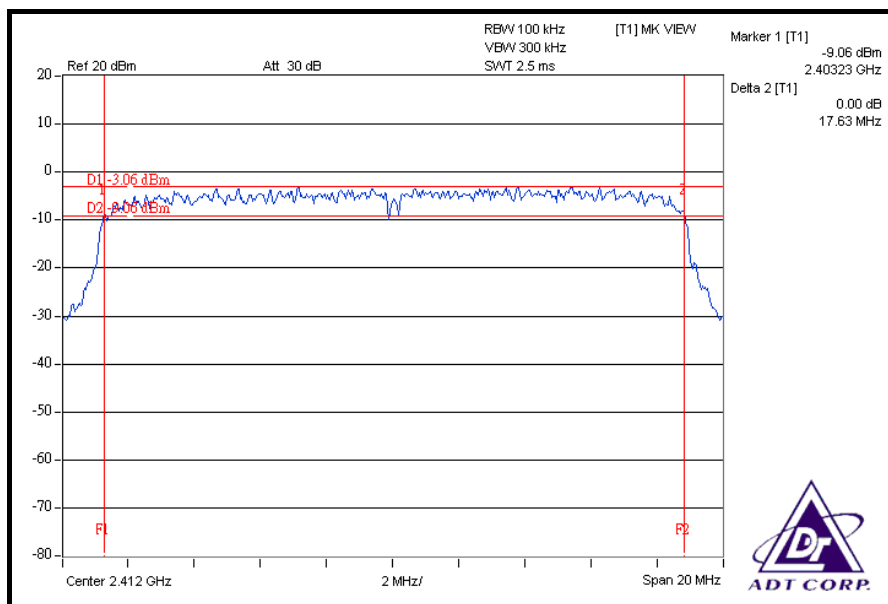



DRAFT 802.11n (40MHz) OFDM MODULATION

MODULATION TYPE	BPSK	TRANSFER RATE	15.0Mbps
INPUT POWER	120Vac, 60Hz	ENVIRONMENTAL CONDITIONS	25 deg.C, 63 %RH, 991hPa
TESTED BY	Match Tsui		

CHANNEL	CHANNEL FREQUENCY (MHz)	6dB BANDWIDTH (MHz)		MINIMUM LIMIT (MHz)	PASS / FAIL
		CHAIN 0	CHAIN 1		
1	2422	36.03	36.08	0.5	PASS
4	2437	36.36	35.25	0.5	PASS
7	2452	36.20	36.39	0.5	PASS

FOR CHAIN 0: CH 1

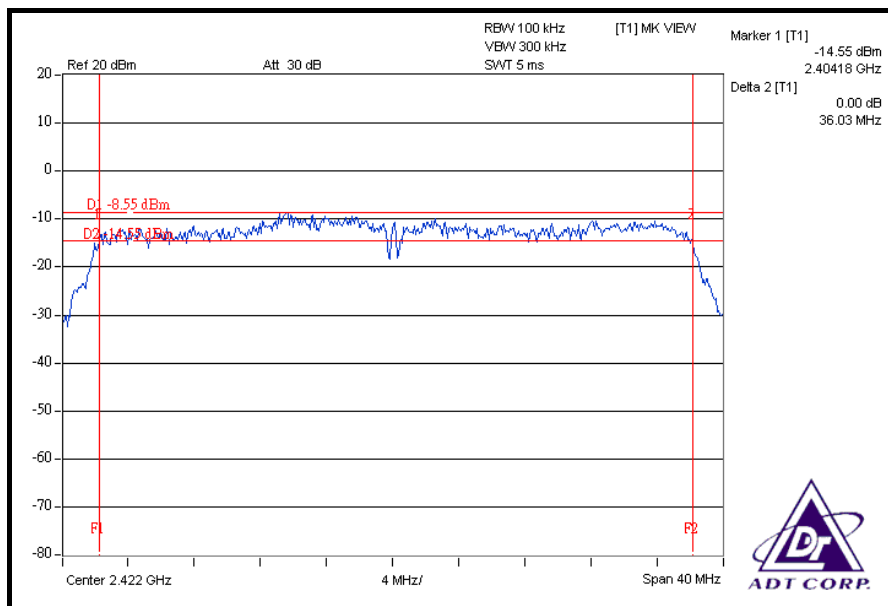

CH 4

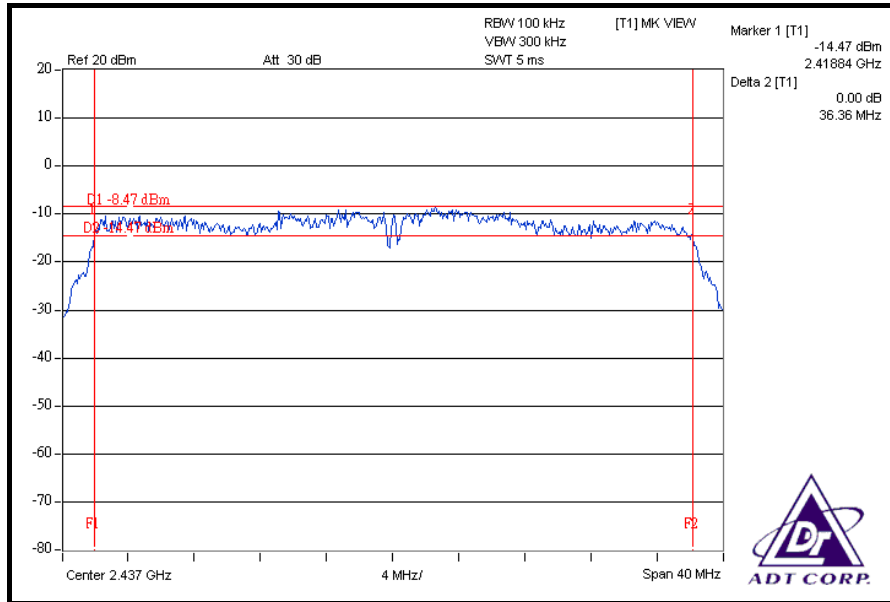

CH 7

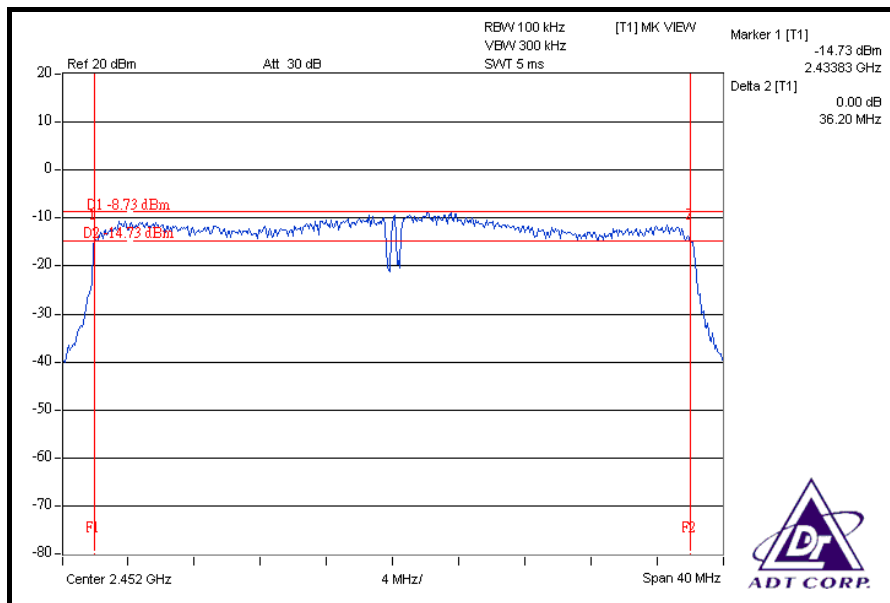

FOR CHAIN 1: CH 1

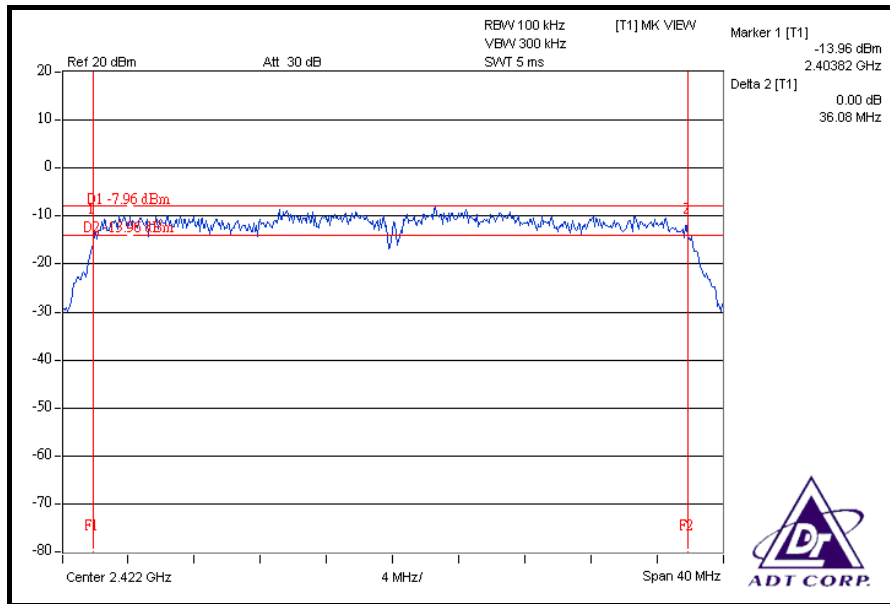

CH 4

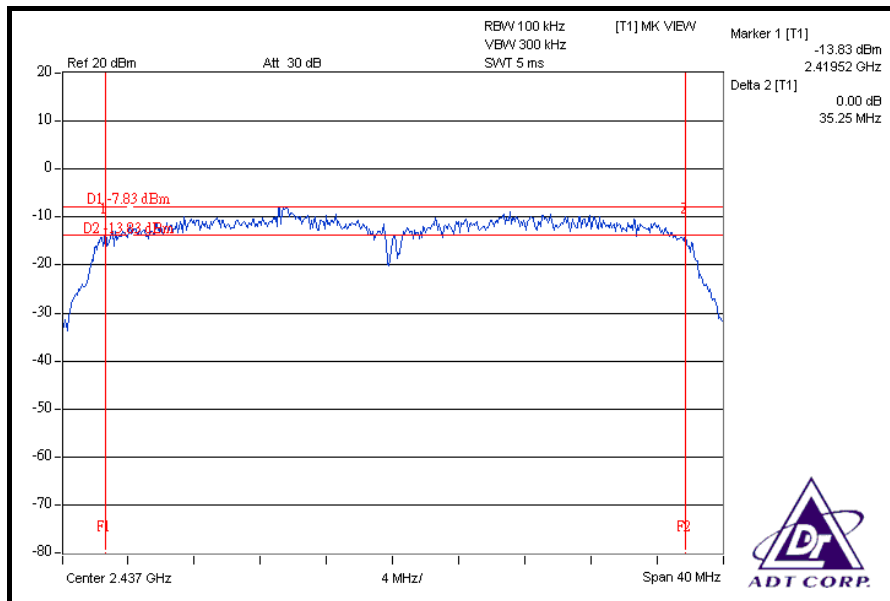

CH 7

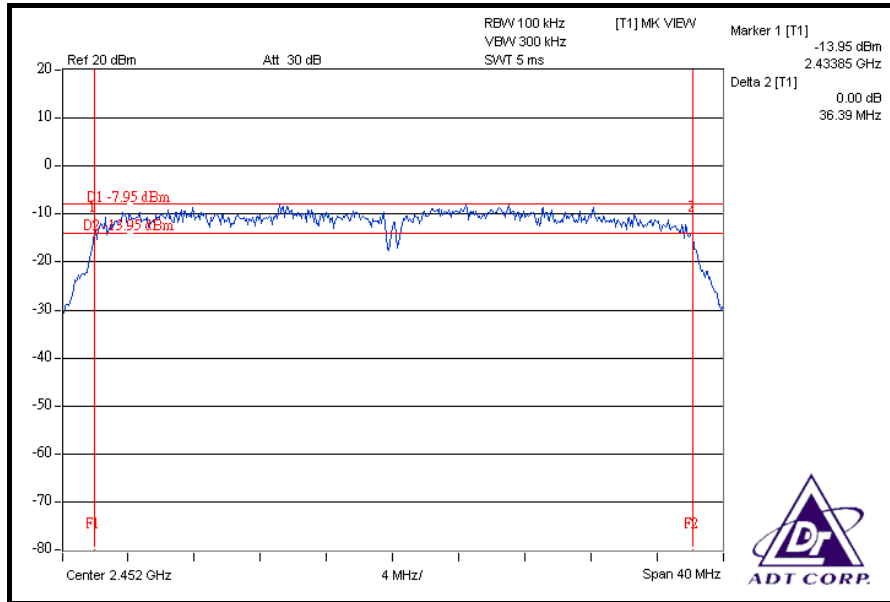



4.4 MAXIMUM PEAK OUTPUT POWER

4.4.1 LIMITS OF MAXIMUM PEAK OUTPUT POWER MEASUREMENT

The Maximum Peak Output Power Measurement is 30dBm.

4.4.2 INSTRUMENTS

DESCRIPTION & MANUFACTURER	MODEL NO.	SERIAL NO.	DATE OF CALIBRATION	CALIBRATED UNTIL
High Speed Peak Power Meter	ML2495A	0824012	Aug. 04, 2008	Aug. 03, 2009
Power Sensor	MA2444B	0738138	Aug. 04, 2008	Aug. 03, 2009

NOTE:

1. The calibration interval of the above test instruments is 12 months and the calibrations are traceable to NML/ROC and NIST/USA.
2. Measurement Bandwidth of ML2495A is 65MHz greater than 6dB bandwidth of emission.

4.4.3 TEST PROCEDURES

A power sensor was used on the output port of the EUT. A power meter was used to read the response of the power sensor. Record the power level.

4.4.4 DEVIATION FROM TEST STANDARD

No deviation.

4.4.5 TEST SETUP

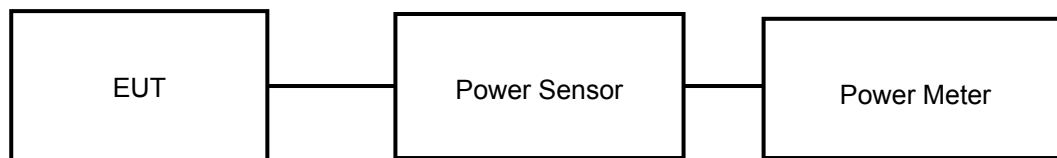

4.4.6 EUT OPERATING CONDITIONS

Same as Item 4.3.6.



4.4.7 TEST RESULTS

802.11b DSSS MODULATION

MODULATION TYPE	DBPSK	TRANSFER RATE	1.0Mbps
INPUT POWER	120Vac, 60Hz	ENVIRONMENTAL CONDITIONS	25 deg.C, 63 %RH, 991hPa
TESTED BY	Match Tsui		

CHANNEL	CHANNEL FREQUENCY (MHz)	PEAK POWER OUTPUT (mW)	PEAK POWER OUTPUT (dBm)	PEAK POWER LIMIT (dBm)	PASS / FAIL
1	2412	89.950	19.54	30	PASS
6	2437	90.782	19.58	30	PASS
11	2462	89.536	19.52	30	PASS

802.11g OFDM MODULATION

MODULATION TYPE	BPSK	TRANSFER RATE	6.0Mbps
INPUT POWER	120Vac, 60Hz	ENVIRONMENTAL CONDITIONS	25 deg.C, 63 %RH, 991hPa
TESTED BY	Match Tsui		

CHANNEL	CHANNEL FREQUENCY (MHz)	PEAK POWER OUTPUT (mW)	PEAK POWER OUTPUT (dBm)	PEAK POWER LIMIT (dBm)	PASS / FAIL
1	2412	254.683	24.06	30	PASS
6	2437	283.792	24.53	30	PASS
11	2462	203.704	23.09	30	PASS



DRAFT 802.11n (20MHz) OFDM MODULATION

MODULATION TYPE	BPSK	TRANSFER RATE	7.2Mbps
INPUT POWER	120Vac, 60Hz	ENVIRONMENTAL CONDITIONS	25 deg.C, 63 %RH, 991hPa
TESTED BY	Match Tsui		

CHAN.	CHAN. FREQ. (MHz)	PEAK POWER OUTPUT (dBm)		TOTAL PEAK POWER (mW)	TOTAL PEAK POWER (dBm)	PEAK POWER LIMIT (dBm)	PASS / FAIL
		CHAIN 0	CHAIN 1				
1	2412	22.09	22.06	322.502	25.09	30	PASS
6	2437	22.04	22.08	321.392	25.07	30	PASS
11	2462	22.07	22.13	324.370	25.11	30	PASS

DRAFT 802.11n (40MHz) OFDM MODULATION

MODULATION TYPE	BPSK	TRANSFER RATE	15.0Mbps
INPUT POWER	120Vac, 60Hz	ENVIRONMENTAL CONDITIONS	25deg.C, 65%RH, 991hPa
TESTED BY	Match Tsui		

CHAN.	CHAN. FREQ. (MHz)	PEAK POWER OUTPUT (dBm)		TOTAL PEAK POWER (mW)	TOTAL PEAK POWER (dBm)	PEAK POWER LIMIT (dBm)	PASS / FAIL
		CHAIN 0	CHAIN 1				
1	2422	16.56	17.08	96.340	19.84	30	PASS
4	2437	16.53	17.05	95.677	19.81	30	PASS
7	2452	16.58	17.03	95.965	19.82	30	PASS



4.5 POWER SPECTRAL DENSITY MEASUREMENT

4.5.1 LIMITS OF POWER SPECTRAL DENSITY MEASUREMENT

The Maximum of Power Spectral Density Measurement is 8dBm.

4.5.2 TEST INSTRUMENTS

DESCRIPTION & MANUFACTURER	MODEL NO.	SERIAL NO.	DATE OF CALIBRATION	CALIBRATED UNTIL
R&S SPECTRUM ANALYZER	FSP40	100041	Apr. 22, 2008	Apr. 21, 2009

NOTE: The calibration interval of the above test instruments is 12 months and the calibrations are traceable to NML/ROC and NIST/USA.

4.5.3 TEST PROCEDURE

The transmitter output was connected to the spectrum analyzer through an attenuator, the bandwidth of the fundamental frequency was measured with the spectrum analyzer using 3kHz RBW and 30kHz VBW, set sweep time = span/3kHz. The power spectral density was measured and recorded.

The sweep time is allowed to be longer than span/3kHz for a full response of the mixer in the spectrum analyzer.

4.5.4 DEVIATION FROM TEST STANDARD

No deviation

4.5.5 TEST SETUP

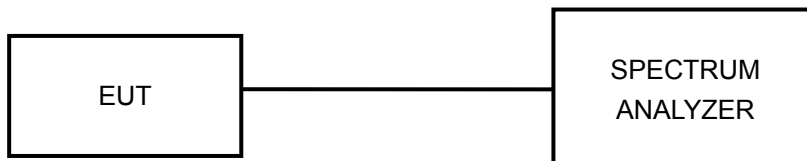

4.5.6 EUT OPERATING CONDITION

Same as Item 4.3.6

4.5.7 TEST RESULTS

802.11b DSSS MODULATION

MODULATION TYPE	DBPSK	TRANSFER RATE	1.0Mbps
INPUT POWER	120Vac, 60Hz	ENVIRONMENTAL CONDITIONS	25 deg.C, 63 %RH, 991hPa
TESTED BY	Match Tsui		

CHANNEL	CHANNEL FREQUENCY (MHz)	RF POWER LEVEL IN 3kHz BW (dBm)	MAXIMUM LIMIT (dBm)	PASS / FAIL
1	2412	-8.65	8	PASS
6	2437	-8.50	8	PASS
11	2462	-8.68	8	PASS

CH 1

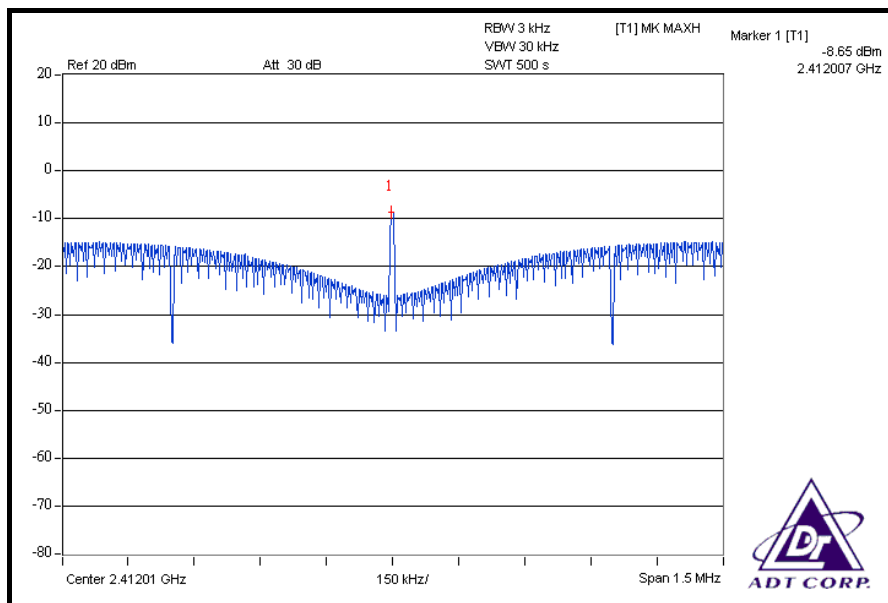

802.11g OFDM MODULATION

MODULATION TYPE	BPSK	TRANSFER RATE	6.0Mbps
INPUT POWER	120Vac, 60Hz	ENVIRONMENTAL CONDITIONS	25deg.C, 65%RH, 991hPa
TESTED BY	Long Chen		

CHANNEL	CHANNEL FREQUENCY (MHz)	RF POWER LEVEL IN 3kHz BW (dBm)	MAXIMUM LIMIT (dBm)	PASS / FAIL
1	2412	-5.80	8	PASS
6	2437	-5.40	8	PASS
11	2462	-6.61	8	PASS

CH 1

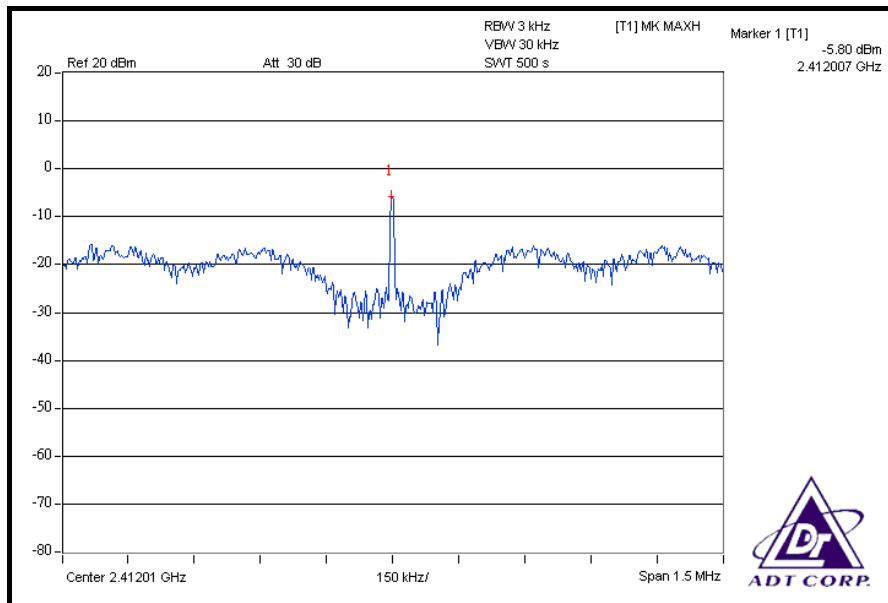

CH 6

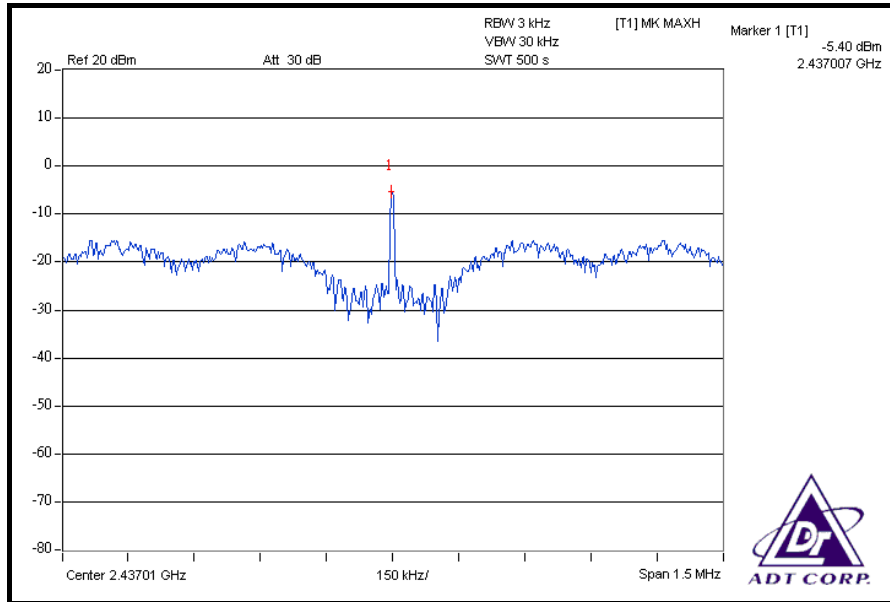

CH 11

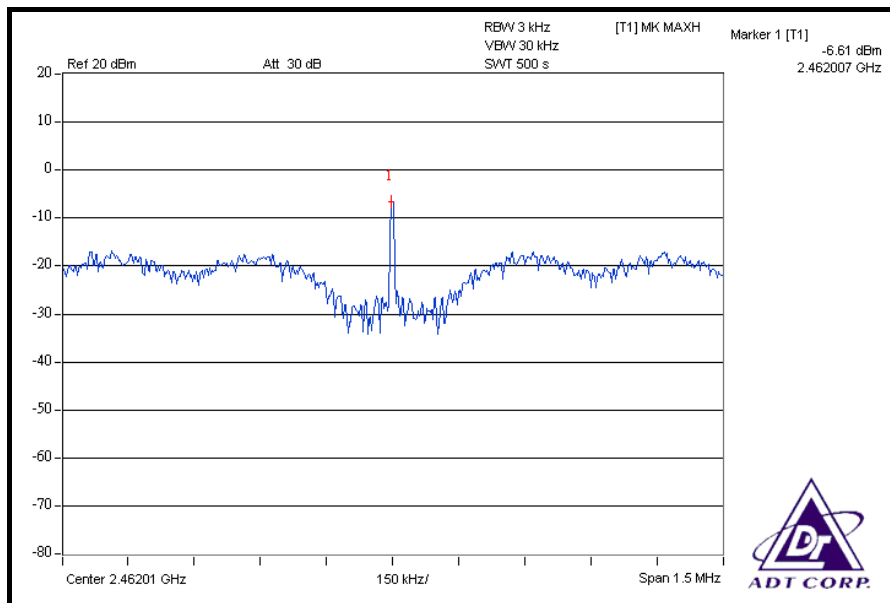



DRAFT 802.11n (20MHz) OFDM MODULATION

MODULATION TYPE	BPSK	TRANSFER RATE	7.2Mbps
INPUT POWER	120Vac, 60Hz	ENVIRONMENTAL CONDITIONS	25 deg.C, 63 %RH, 991hPa
TESTED BY	Match Tsui		

CHAN.	CHAN. FREQ. (MHz)	RF POWER LEVEL IN 3kHz BW (dBm)		TOTAL POWER DENSITY (mW)	TOTAL POWER DENSITY (dBm)	MAX. LIMIT (dBm)	PASS / FAIL
		CHAIN 0	CHAIN 1				
1	2412	-8.29	-9.69	0.256	-5.92	8	PASS
6	2437	-8.39	-9.79	0.250	-6.02	8	PASS
11	2462	-8.47	-9.45	0.256	-5.92	8	PASS

FOR CHAIN 0: CH 1

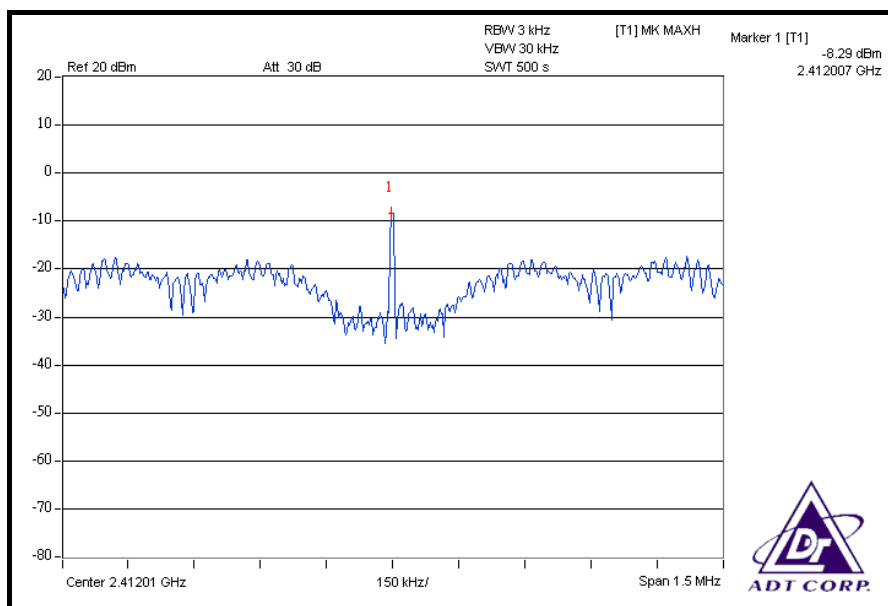

CH 6

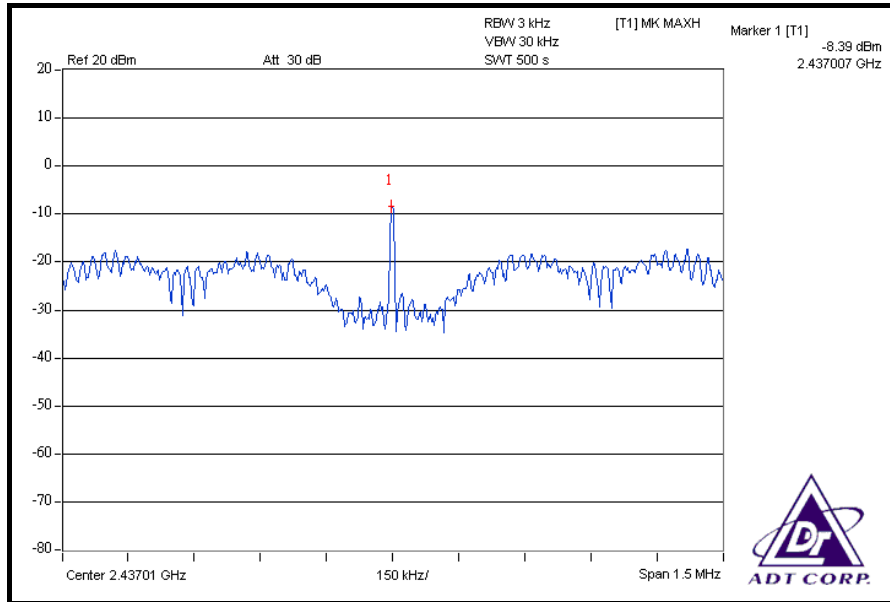

CH 11

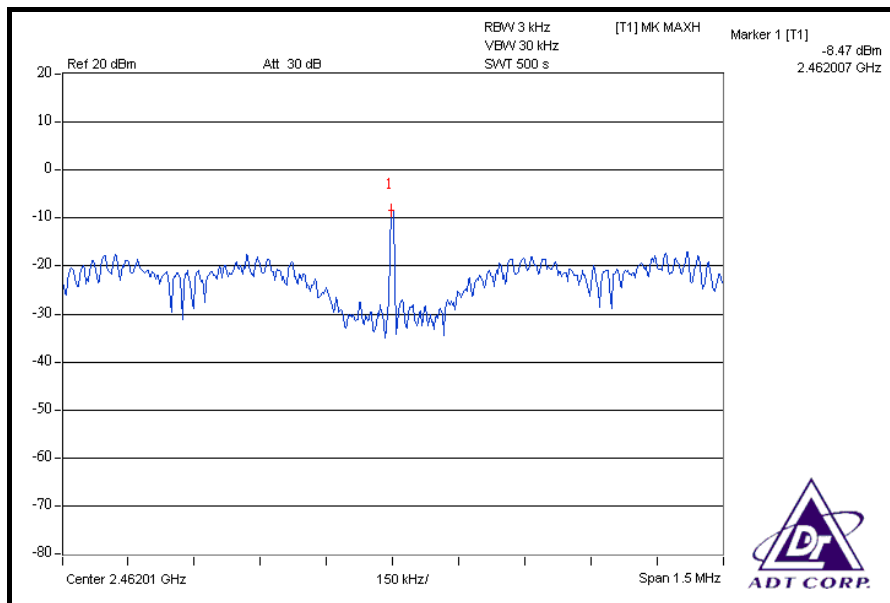

FOR CHAIN 1: CH 1

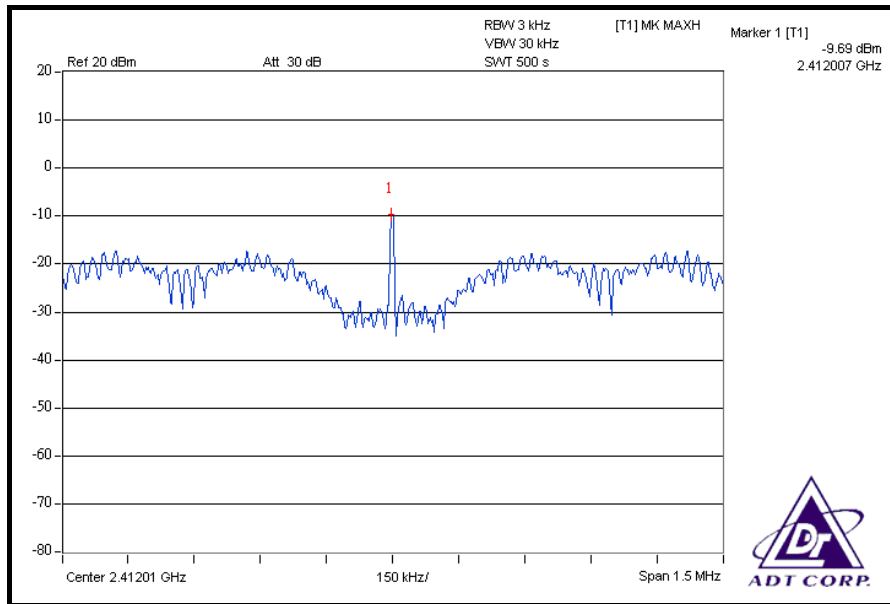

CH 6

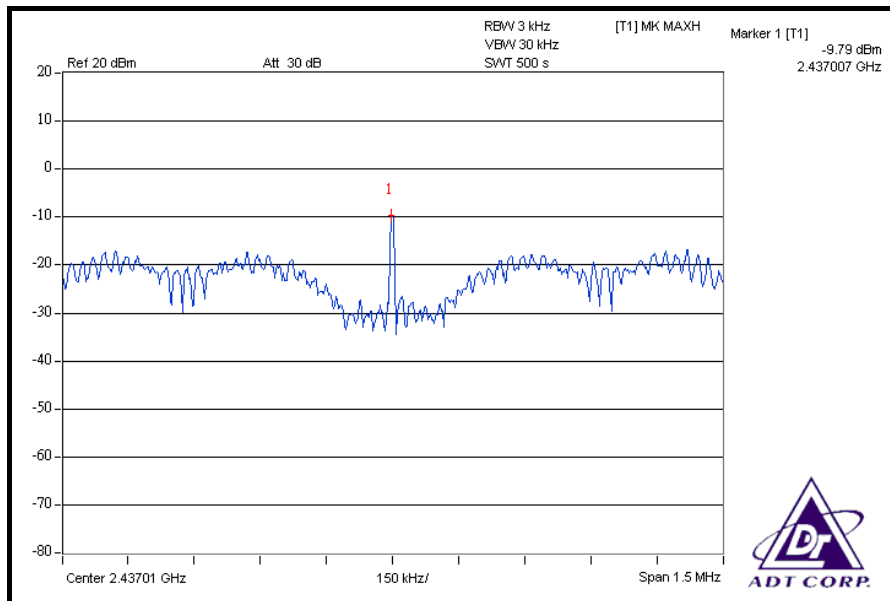

CH 11

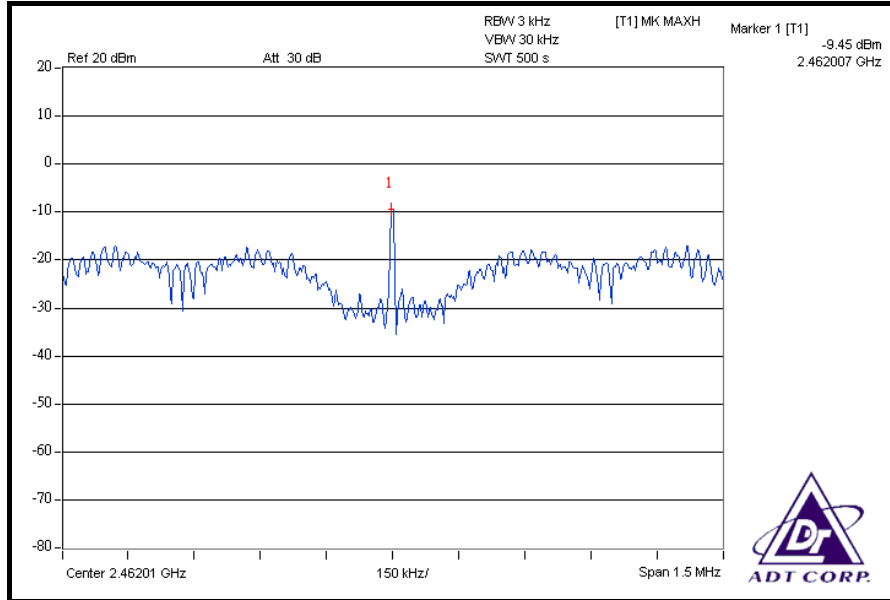



DRAFT 802.11n (40MHz) OFDM MODULATION

MODULATION TYPE	BPSK	TRANSFER RATE	15.0Mbps
INPUT POWER	120Vac, 60Hz	ENVIRONMENTAL CONDITIONS	25 deg.C, 63 %RH, 991hPa
TESTED BY	Match Tsui		

CHAN.	CHAN. FREQ. (MHz)	RF POWER LEVEL IN 3kHz BW (dBm)		TOTAL POWER DENSITY (mW)	TOTAL POWER DENSITY (dBm)	MAX. LIMIT (dBm)	PASS / FAIL
		CHAIN 0	CHAIN 1				
1	2422	-13.21	-14.28	0.085	-10.70	8	PASS
4	2437	-13.02	-14.06	0.089	-10.50	8	PASS
7	2452	-13.03	-14.12	0.088	-10.53	8	PASS

FOR CHAIN 0: CH 1

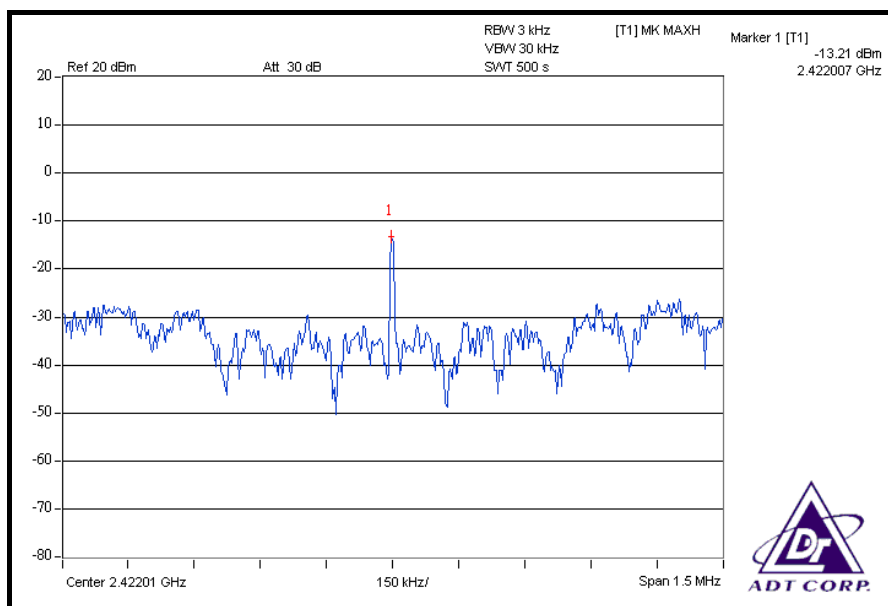

FOR CHAIN 1: CH 1

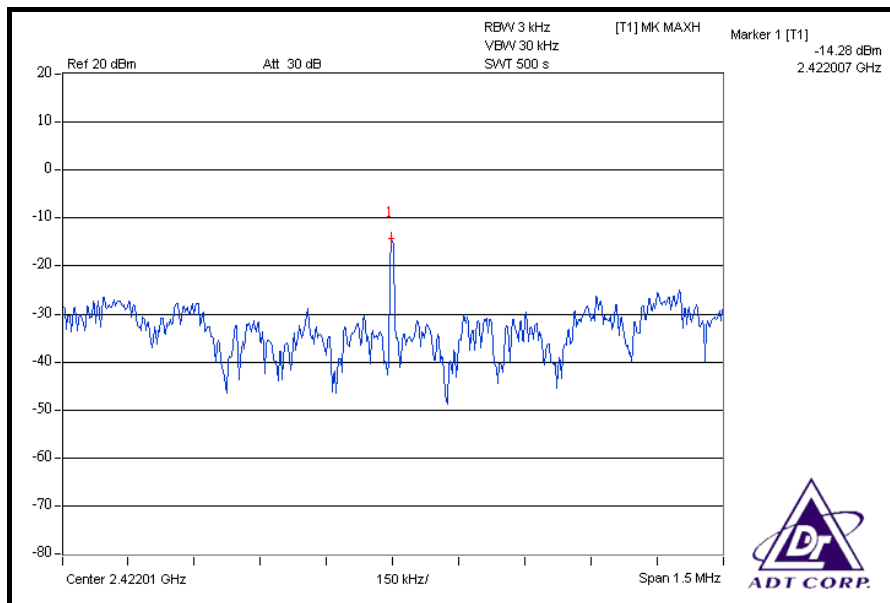

CH 4

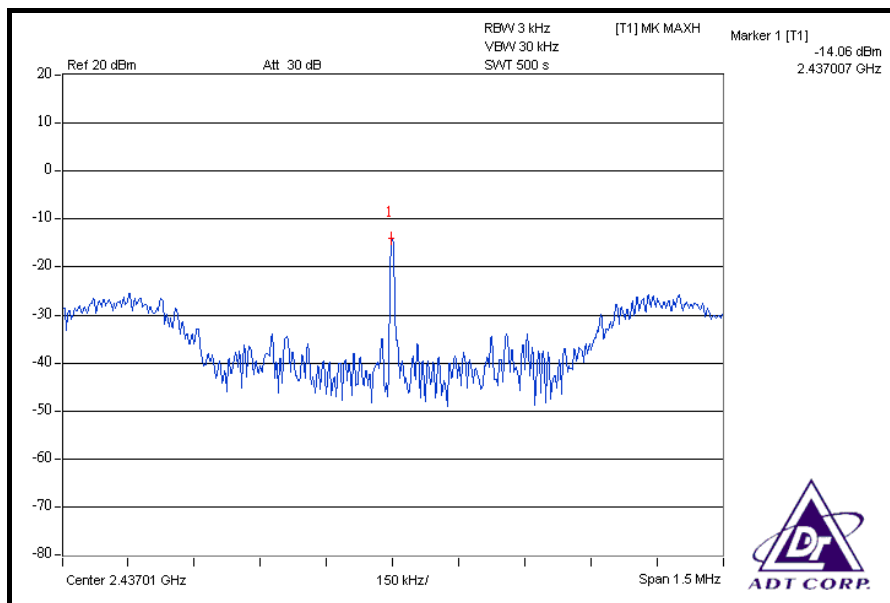

CH 7

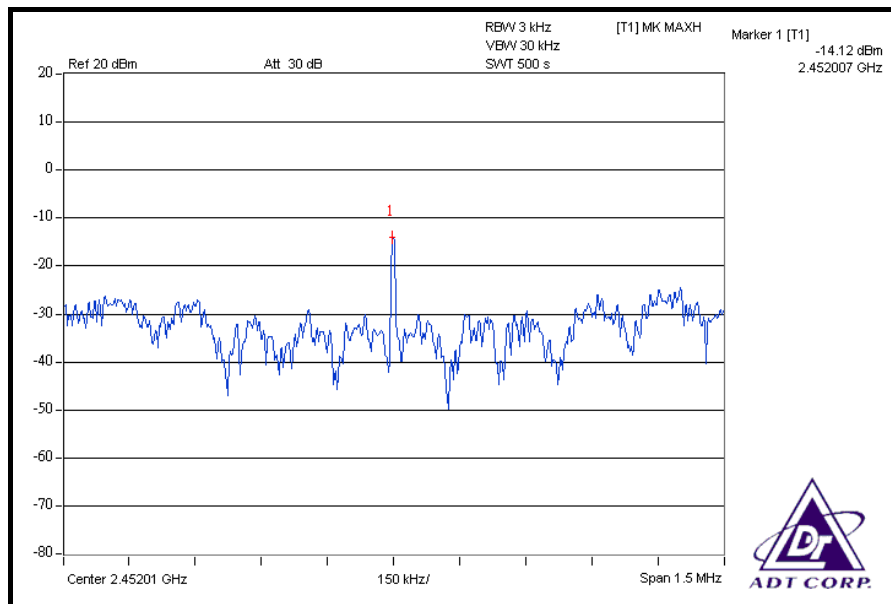



4.6 BAND EDGES MEASUREMENT

4.6.1 LIMITS OF BAND EDGES MEASUREMENT

Below -20dB of the highest emission level of operating band (in 100kHz Resolution Bandwidth).

4.6.2 TEST INSTRUMENTS

DESCRIPTION & MANUFACTURER	MODEL NO.	SERIAL NO.	DATE OF CALIBRATION	DUE DATE OF CALIBRATION
FOR CONDUCTED MEASUREMENT				
R&S SPECTRUM ANALYZER	FSP40	100041	Apr. 22, 2008	Apr. 21, 2009
FOR RADIATED MEASUREMENT				
Test Receiver ROHDE & SCHWARZ	ESI7	838496/016	Dec. 26, 2007	Dec. 25, 2008
Spectrum Analyzer ROHDE & SCHWARZ	FSP40	100039	Dec. 03, 2007	Dec. 02, 2008
BILOG Antenna SCHWARZBECK	VULB9168	9168-155	Apr. 30, 2008	Apr. 29, 2009
HORN Antenna SCHWARZBECK	BBHA 9120D	9120D-408	Jan. 22, 2008	Jan. 21, 2009
HORN Antenna SCHWARZBECK	BBHA 9170	BBHA9170242	Jan. 07, 2008	Jan. 06, 2009
Preamplifier Agilent	8449B	3008A01960	Oct. 31, 2007	Oct. 30, 2008
Preamplifier Agilent	8447D	2944A10631	Nov. 01, 2007	Oct. 31, 2008
RF signal cable HUBER+SUHNNER	SUCOFLEX 104	274397/4	Nov. 08, 2007	Nov. 07, 2008
RF signal cable HUBER+SUHNNER	SUCOFLEX 104	283401/4	Nov. 08, 2007	Nov. 07, 2008
Software ADT.	ADT_Radiated_V7.6	NA	NA	NA
Antenna Tower inn-co GmbH	MA 4000	010303	NA	NA
Antenna Tower Controller inn-co GmbH	CO2000	019303	NA	NA
Turn Table ADT.	TT100.	TT93021704	NA	NA
Turn Table Controller ADT.	SC100.	SC93021704	NA	NA

NOTE: The calibration interval of the above test instruments is 12 months and the calibrations are traceable to NML/ROC and NIST/USA.

4.6.3 TEST PROCEDURE

FOR CONDUCTED MEASUREMENT:

The transmitter output was connected to the spectrum analyzer via a low loss cable. Set both RBW and VBW of spectrum analyzer to 100kHz and 300kHz with suitable frequency span including 100MHz bandwidth from band edge. The band edges was measured and recorded.

The spectrum plots (Peak RBW = 100kHz, VBW = 300kHz) are attached on the following pages.

FOR RADIATED MEASUREMENT:

- a. The EUT was placed on the top of a rotating table 0.8 meters above the ground at a 3 meter semi-anechoic chamber. The table was rotated 360 degrees to determine the position of the highest radiation.
- b. The EUT was set 3 meters away from the interference-receiving antenna, which was mounted on the top of a variable-height antenna tower.
- c. The antenna is a broadband antenna, and its height is varied from one meter to four meters above the ground to determine the maximum value of the field strength. Both horizontal and vertical polarizations of the antenna are set to make the measurement.
- d. For each suspected emission, the EUT was arranged to its worst case and then the antenna was tuned to heights from 1 meter to 4 meters and the rotatable table was turned from 0 degrees to 360 degrees to find the maximum reading.
- e. Set both RBW and VBW of spectrum analyzer to 100kHz and 300kHz with suitable frequency span including 100MHz bandwidth from band edge. The band edges was measured and recorded.

The spectrum plots (Peak RBW = 100kHz, VBW = 300kHz) are attached on the following pages.

NOTE: The resolution bandwidth of test receiver/spectrum analyzer is 1MHz and the video bandwidth is 10Hz for Average detection (AV) at frequency above 1GHz.

4.6.4 DEVIATION FROM TEST STANDARD

No deviation.

4.6.5 EUT OPERATING CONDITION

Same as Item 4.3.6.

4.6.6 TEST RESULTS

The spectrum plots are attached on the following pages. D1 line indicates the highest level, and D2 line indicates the 20dB offset below D1. It shows compliance with the requirement in part 15.247(d).

802.11b DSSS MODULATION

NOTE 1: The band edge emission plot on the next page shows 49.02dBc between carrier maximum power and local maximum emission in restrict band (2.390000GHz). The emission of carrier strength list in the test result of channel 1 at the item 4.2.7 is 111.13dBuV/m (Peak), so the maximum field strength in restrict band is $111.13 - 49.02 = 62.11$ dBuV/m which is under 74dBuV/m limit.

The band edge emission plot of on the next page shows 54.47dBc between carrier maximum power and local maximum emission in restrict band (2.386800GHz). The emission of carrier strength list in the test result of channel 1 at the item 4.2.7 is 106.46dBuV/m (Average), so the maximum field strength in restrict band is $106.46 - 54.47 = 51.99$ dBuV/m which is under 54dBuV/m limit.

NOTE 2: The band edge emission plot on the next second page shows 50.95dBc between carrier maximum power and local maximum emission in restrict band (2.487000GHz). The emission of carrier strength list in the test result of channel 11 at the item 4.2.7 is 111.21dBuV/m (Peak), so the maximum field strength in restrict band is $111.21 - 50.95 = 60.26$ dBuV/m which is under 74dBuV/m limit.

The band edge emission plot on the next third page shows 57.08dBc between carrier maximum power and local maximum emission in restrict band (2.487800GHz). The emission of carrier strength list in the test result of channel 11 at the item 4.2.7 is 106.46dBuV/m (Average), so the maximum field strength in restrict band is $106.46 - 57.08 = 49.38$ dBuV/m which is under 54dBuV/m limit.

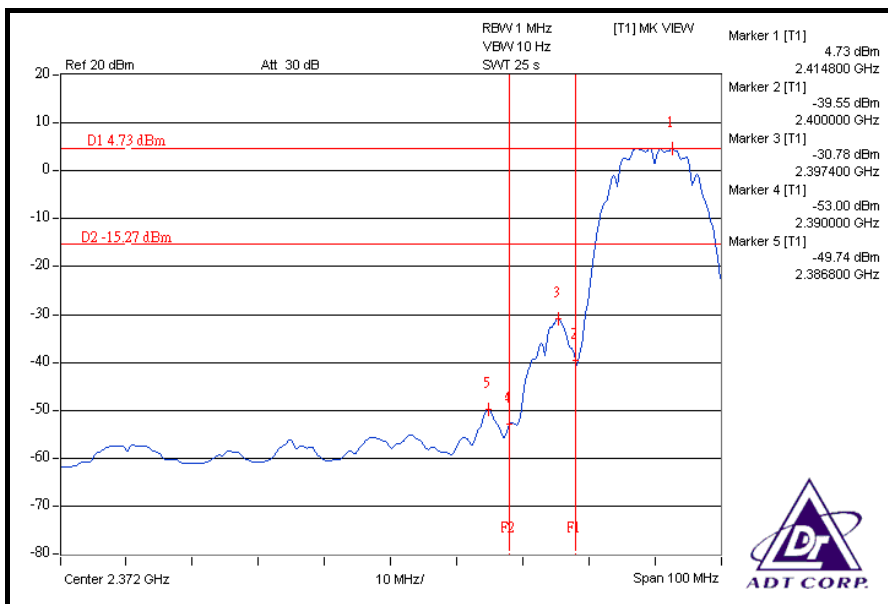
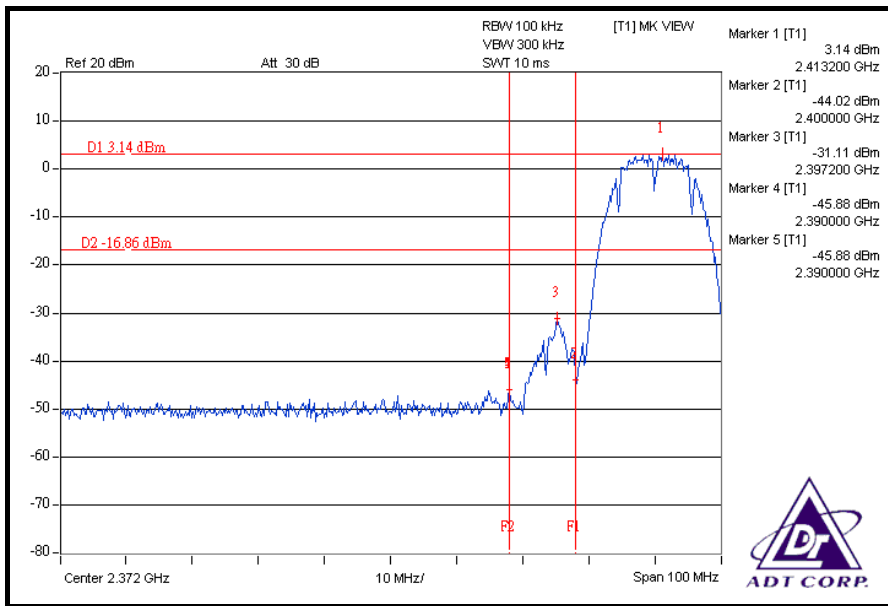

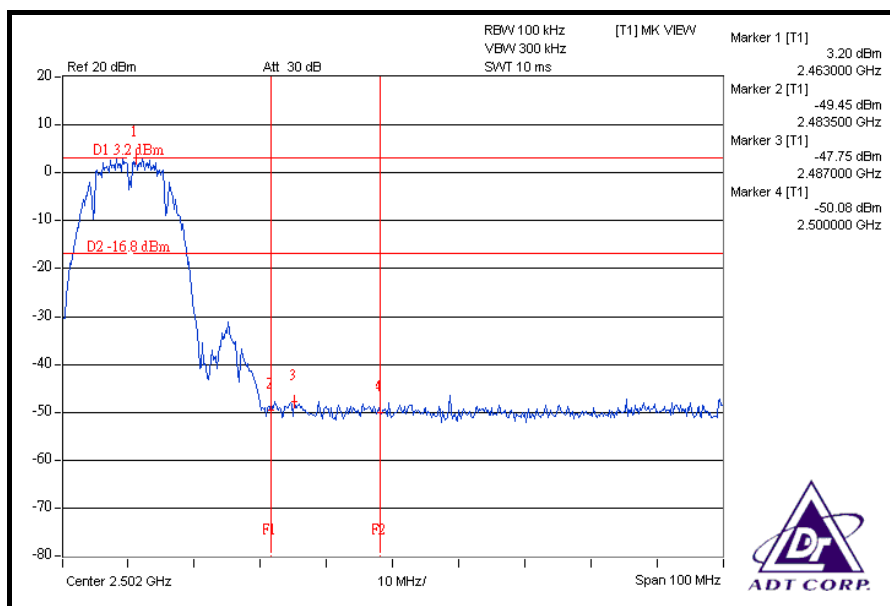
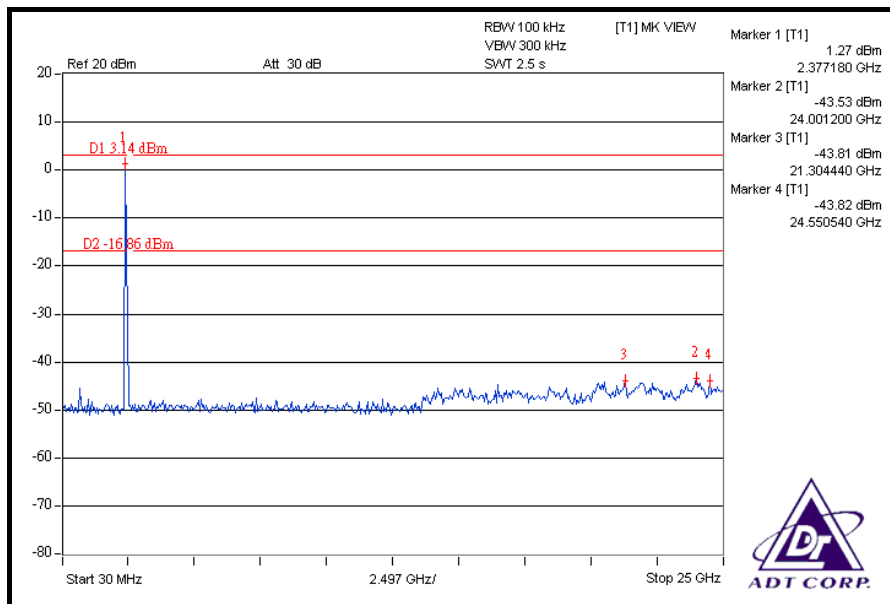

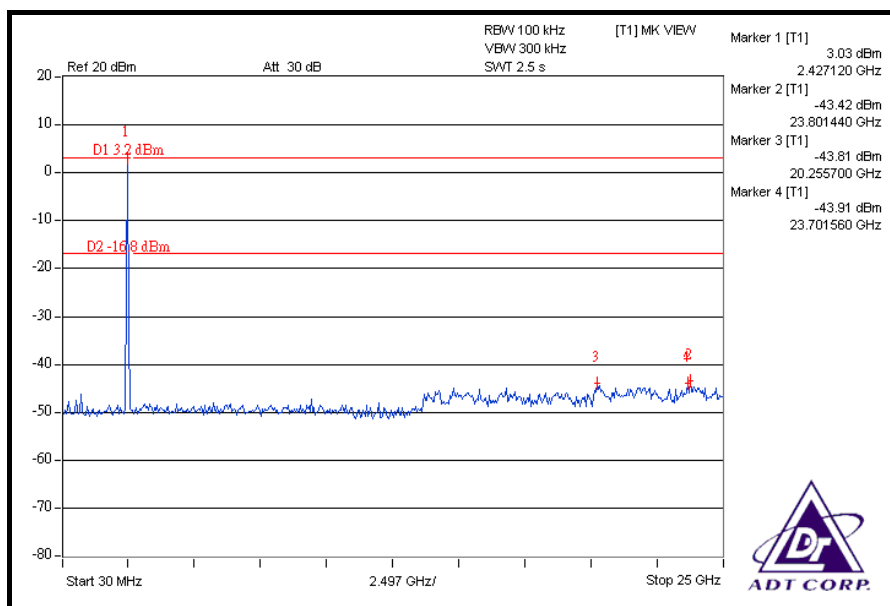
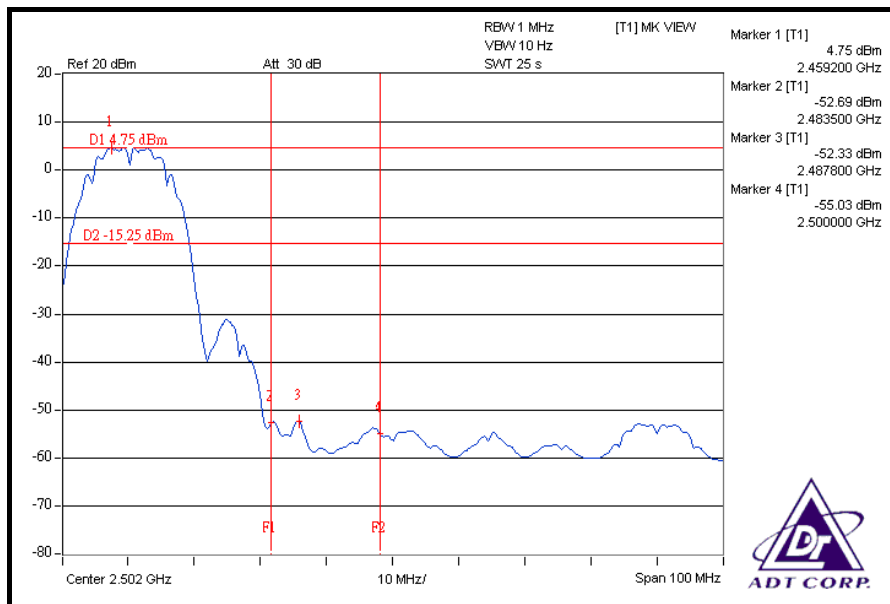

802.11g OFDM MODULATION

NOTE 1: The band edge emission plot on the next page shows 45.57dBc between carrier maximum power and local maximum emission in restrict band (2.390000GHz). The emission of carrier strength list in the test result of channel 1 at the item 4.2.7 is 112.08dBuV/m (Peak), so the maximum field strength in restrict band is $112.08 - 45.57 = 66.51$ dBuV/m which is under 74dBuV/m limit.

The band edge emission plot of on the next page shows 50.51dBc between carrier maximum power and local maximum emission in restrict band (2.390000GHz). The emission of carrier strength list in the test result of channel 1 at the item 4.2.7 is 102.30dBuV/m (Average), so the maximum field strength in restrict band is $102.30 - 50.51 = 51.79$ dBuV/m which is under 54dBuV/m limit.

NOTE 2: The band edge emission plot on the next second page shows 45.67dBc between carrier maximum power and local maximum emission in restrict band (2.485000GHz). The emission of carrier strength list in the test result of channel 11 at the item 4.2.7 is 112.04dBuV/m (Peak), so the maximum field strength in restrict band is $112.04 - 45.67 = 66.37$ dBuV/m which is under 74dBuV/m limit.

The band edge emission plot on the next third page shows 50.88dBc between carrier maximum power and local maximum emission in restrict band (2.483500GHz). The emission of carrier strength list in the test result of channel 11 at the item 4.2.7 is 101.81dBuV/m (Average), so the maximum field strength in restrict band is $101.81 - 50.88 = 50.93$ dBuV/m which is under 54dBuV/m limit.

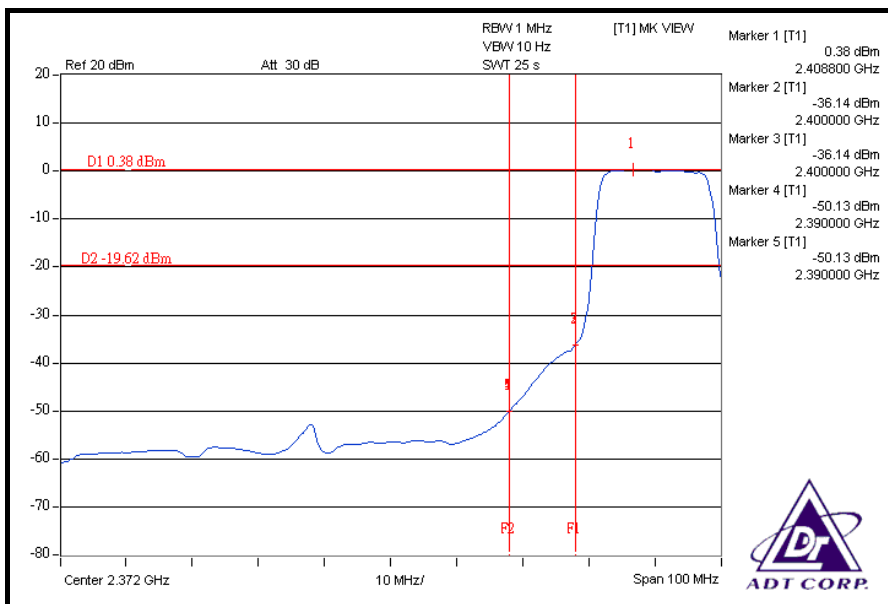
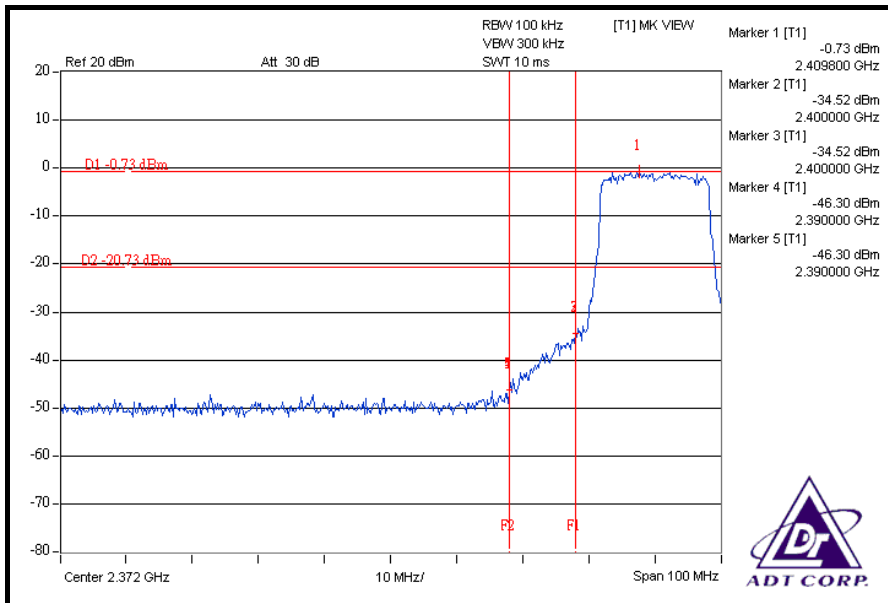

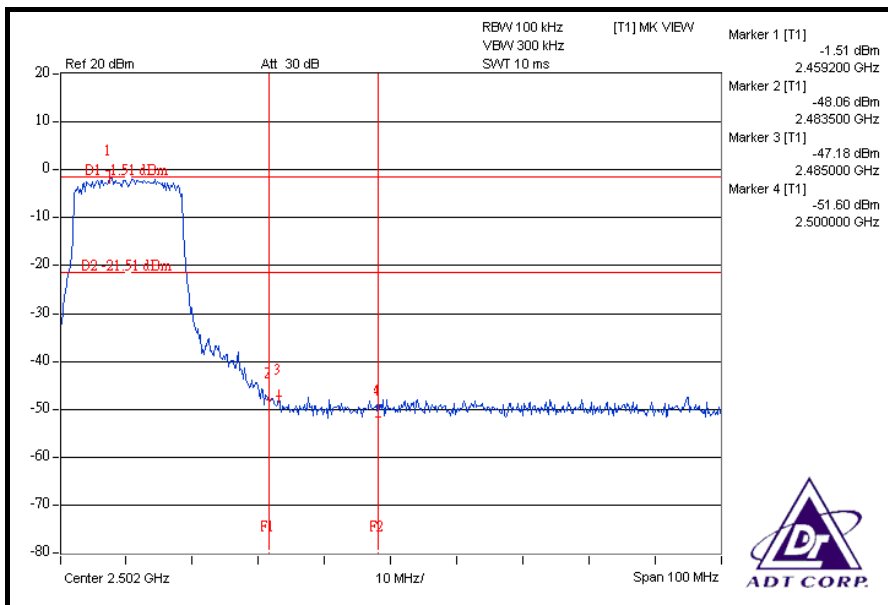
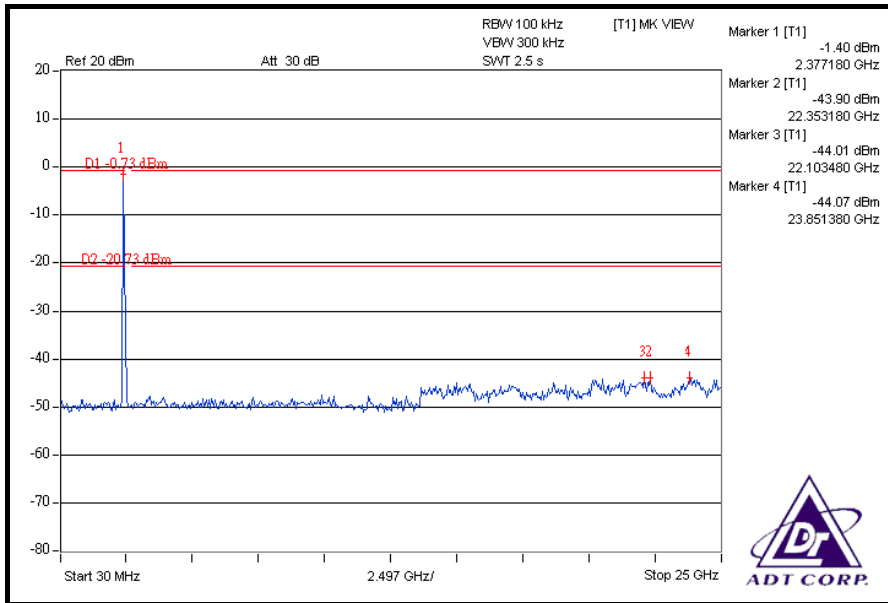

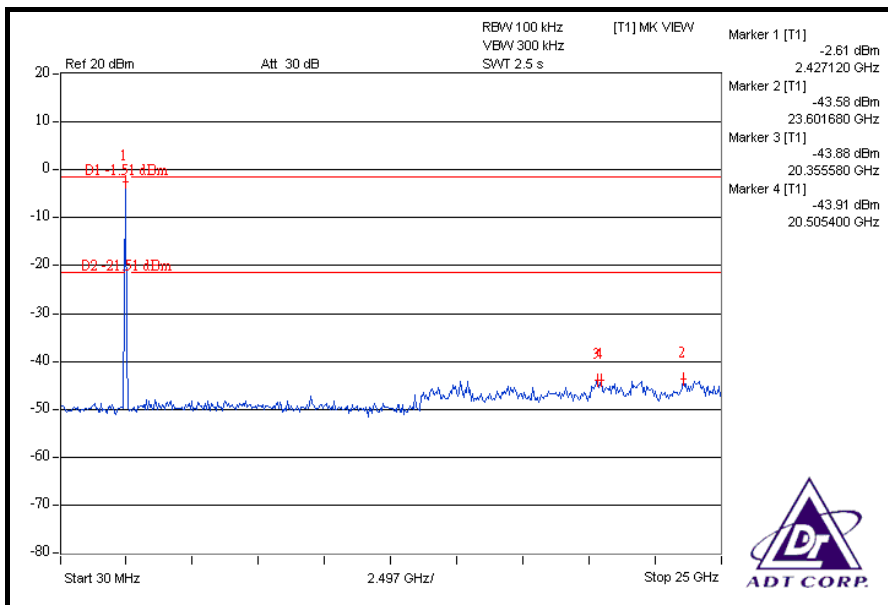
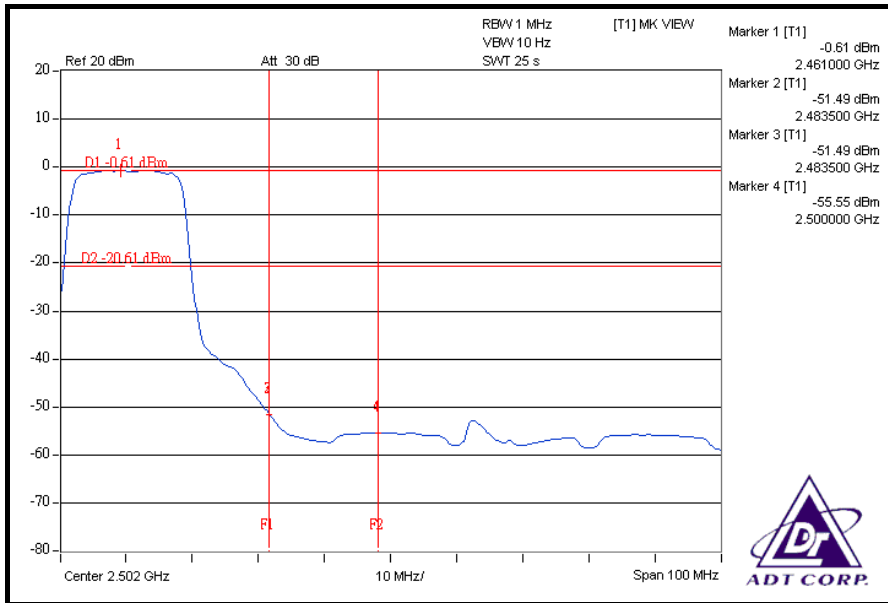

DRAFT 802.11n (20MHz) OFDM MODULATION

NOTE 1: The band edge emission plot on the next page shows 49.15dBc between carrier maximum power and local maximum emission in restrict band (2.360000GHz). The emission of carrier strength list in the test result of channel 1 at the item 4.2.7 is 113.95dBuV/m (Peak), so the maximum field strength in restrict band is $113.95 - 49.15 = 64.80$ dBuV/m which is under 74dBuV/m limit.

The band edge emission plot of on the next page shows 53.92dBc between carrier maximum power and local maximum emission in restrict band (2.390000GHz). The emission of carrier strength list in the test result of channel 1 at the item 4.2.7 is 104.08dBuV/m (Average), so the maximum field strength in restrict band is $104.08 - 53.92 = 50.16$ dBuV/m which is under 54dBuV/m limit.

NOTE 2: The band edge emission plot on the next second page shows 46.78dBc between carrier maximum power and local maximum emission in restrict band (2.483800GHz). The emission of carrier strength list in the test result of channel 11 at the item 4.2.7 is 115.24dBuV/m (Peak), so the maximum field strength in restrict band is $115.24 - 46.78 = 68.46$ dBuV/m which is under 74dBuV/m limit.

The band edge emission plot on the next third page shows 51.73dBc between carrier maximum power and local maximum emission in restrict band (2.483500GHz). The emission of carrier strength list in the test result of channel 11 at the item 4.2.7 is 104.01dBuV/m (Average), so the maximum field strength in restrict band is $104.01 - 51.73 = 52.28$ dBuV/m which is under 54dBuV/m limit.

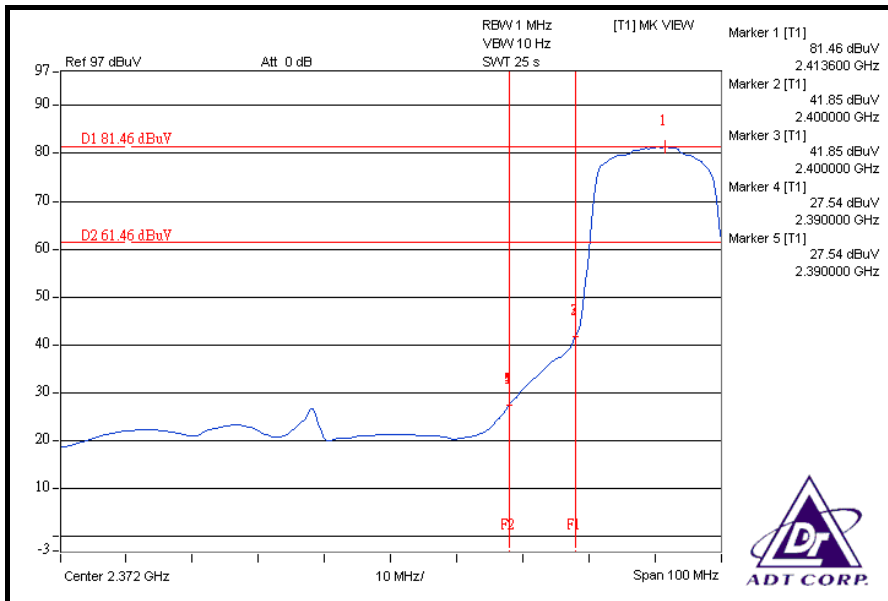
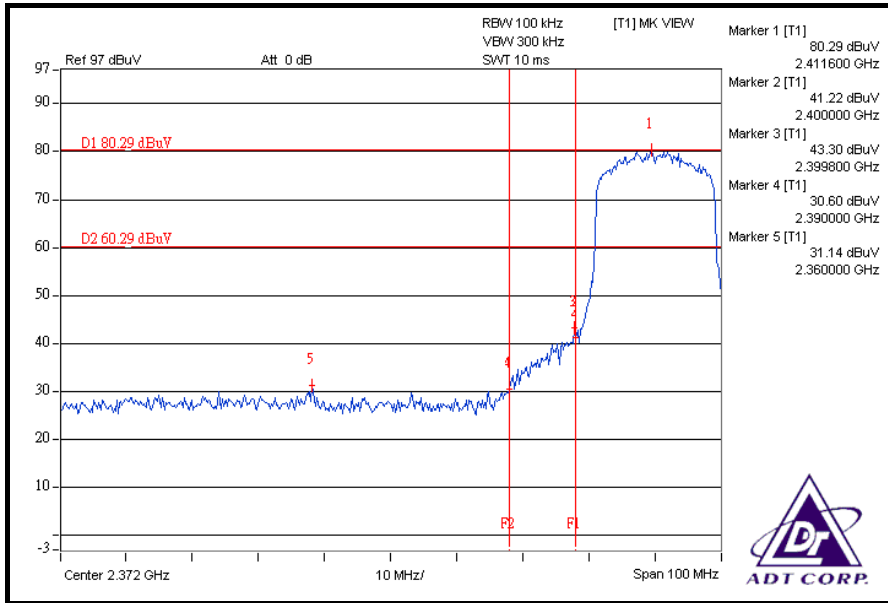

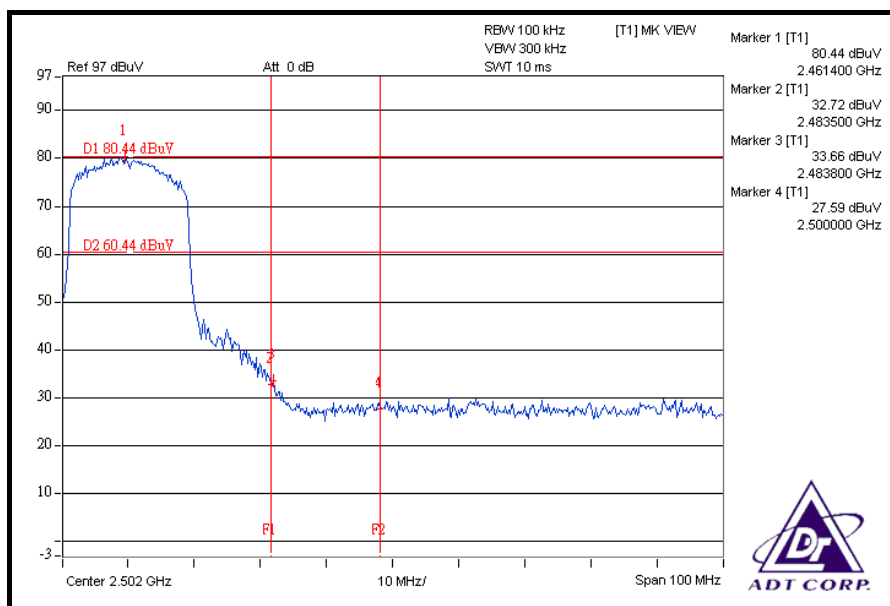
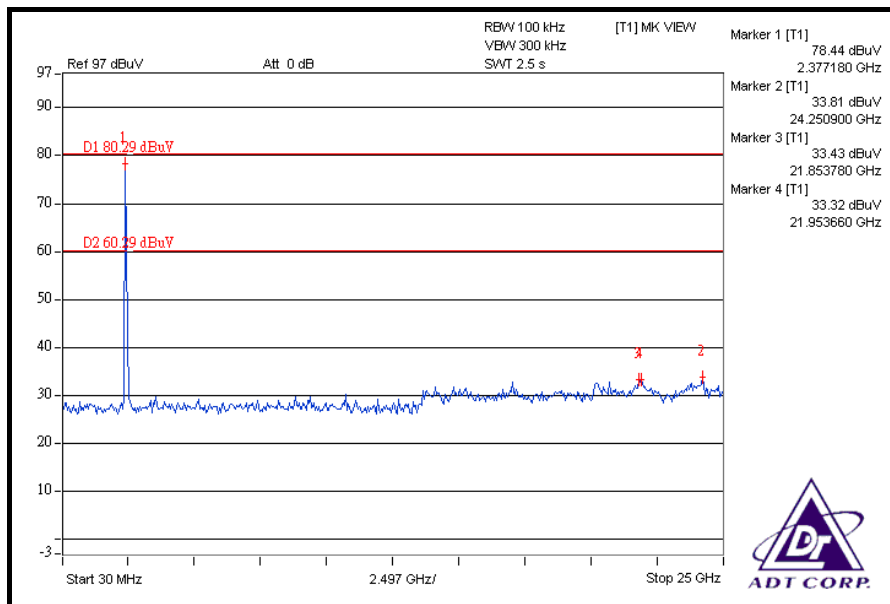

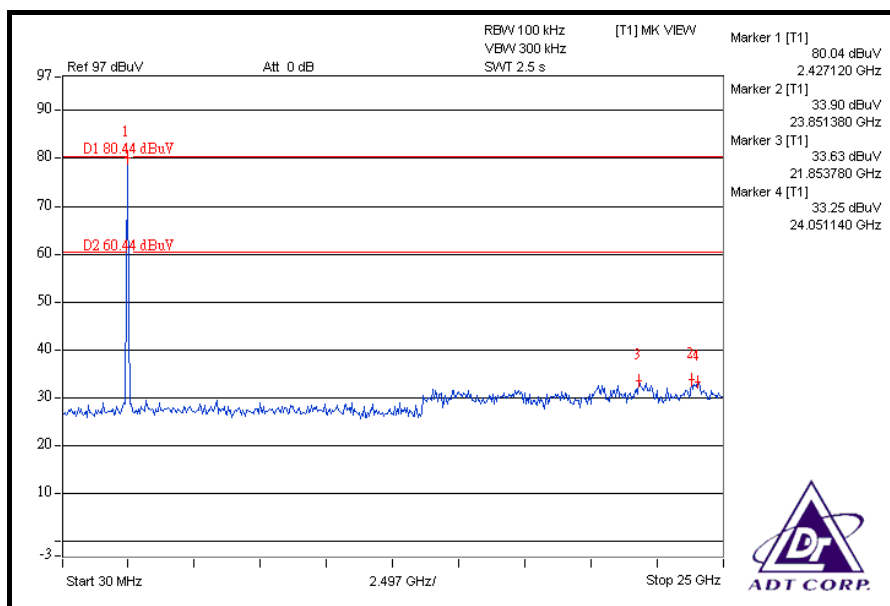
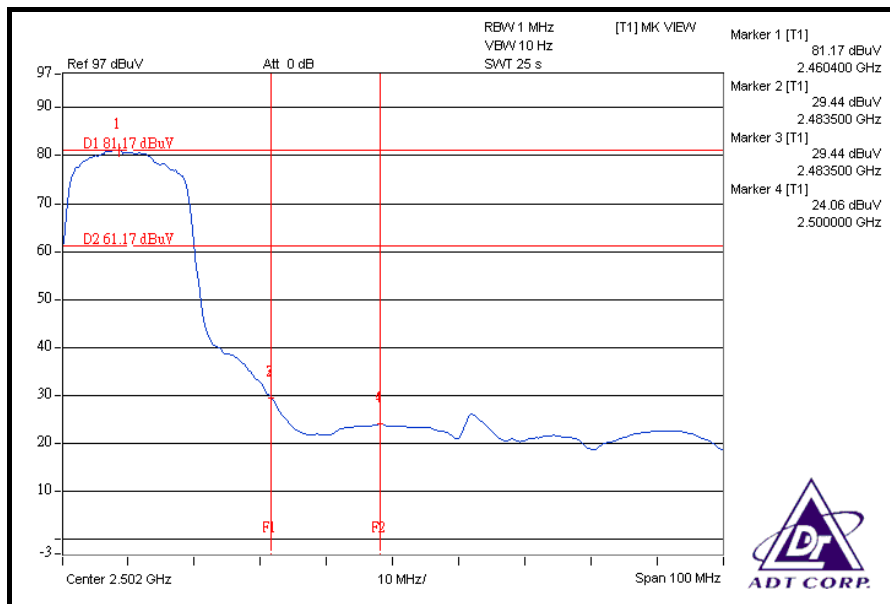

DRAFT 802.11n (40MHz) OFDM MODULATION

NOTE 1: The band edge emission plot on the next page shows 41.71dBc between carrier maximum power and local maximum emission in restrict band (2.388400GHz). The emission of carrier strength list in the test result of channel 1 at the item 4.2.7 is 107.80dBuV/m (Peak), so the maximum field strength in restrict band is $107.80 - 41.71 = 66.09$ dBuV/m which is under 74dBuV/m limit.

The band edge emission plot of on the next page shows 45.56dBc between carrier maximum power and local maximum emission in restrict band (2.390000GHz). The emission of carrier strength list in the test result of channel 1 at the item 4.2.7 is 97.20dBuV/m (Average), so the maximum field strength in restrict band is $97.20 - 45.56 = 51.64$ dBuV/m which is under 54dBuV/m limit.

NOTE 2: The band edge emission plot on the next second page shows 42.28dBc between carrier maximum power and local maximum emission in restrict band (2.484000GHz). The emission of carrier strength list in the test result of channel 7 at the item 4.2.7 is 107.24dBuV/m (Peak), so the maximum field strength in restrict band is $107.24 - 42.28 = 64.96$ dBuV/m which is under 74dBuV/m limit.

The band edge emission plot on the next third page shows 44.25dBc between carrier maximum power and local maximum emission in restrict band (2.483500GHz). The emission of carrier strength list in the test result of channel 7 at the item 4.2.7 is 96.55dBuV/m (Average), so the maximum field strength in restrict band is $96.55 - 44.25 = 52.30$ dBuV/m which is under 54dBuV/m limit.

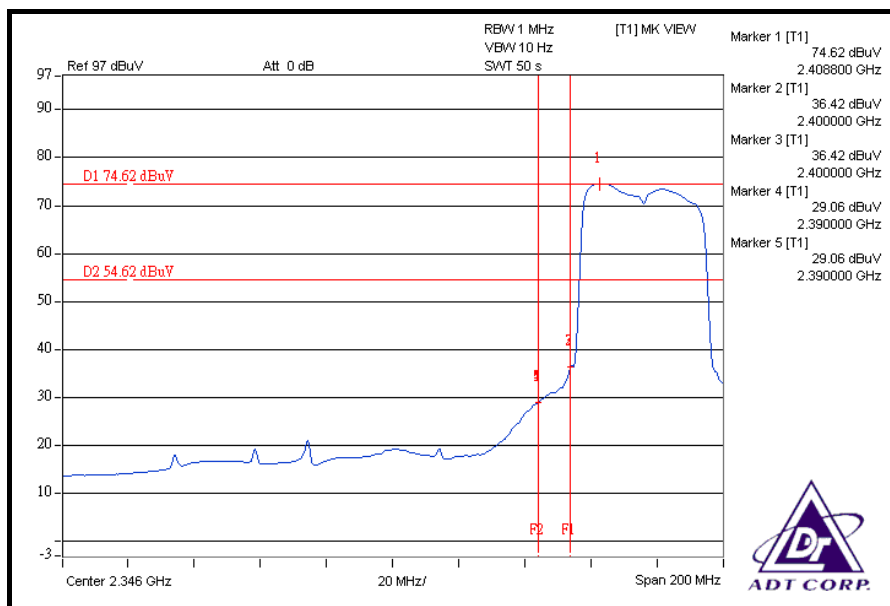
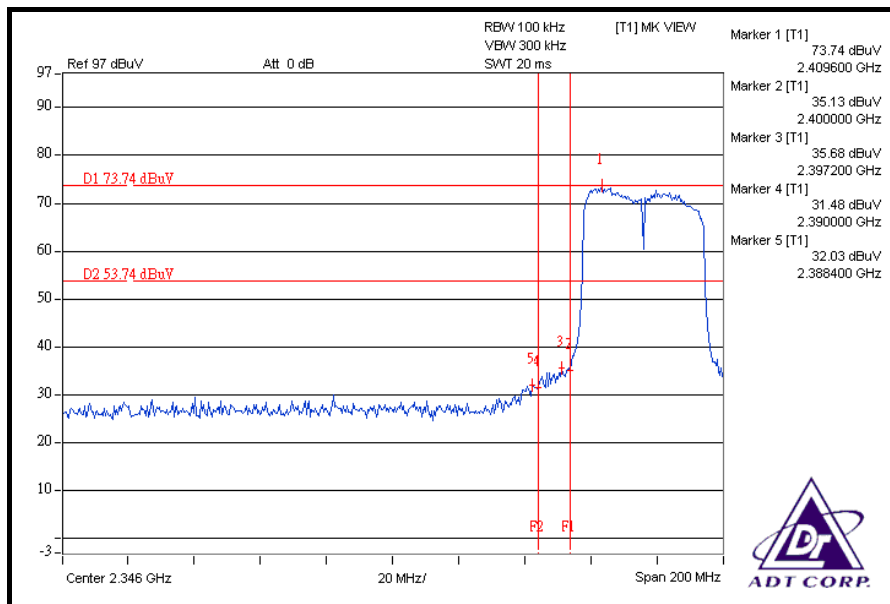

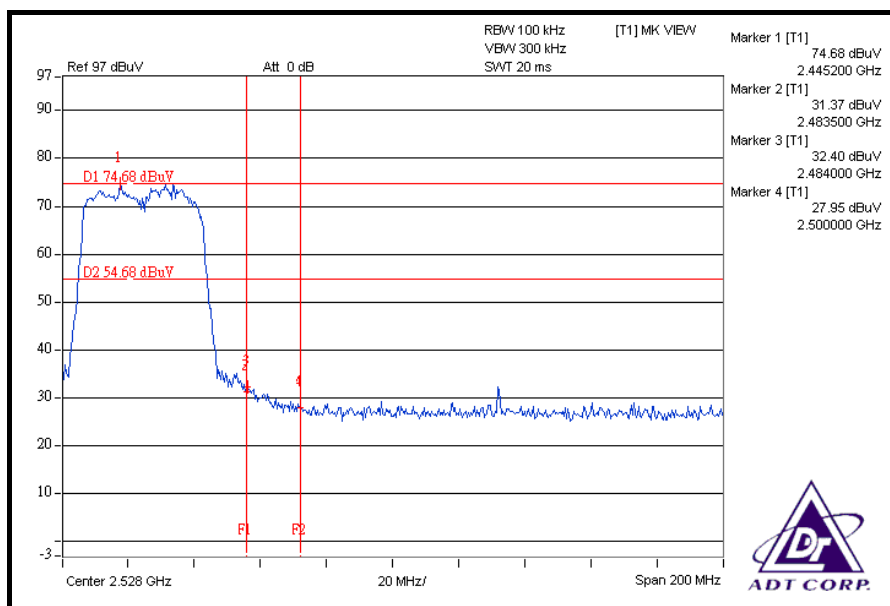
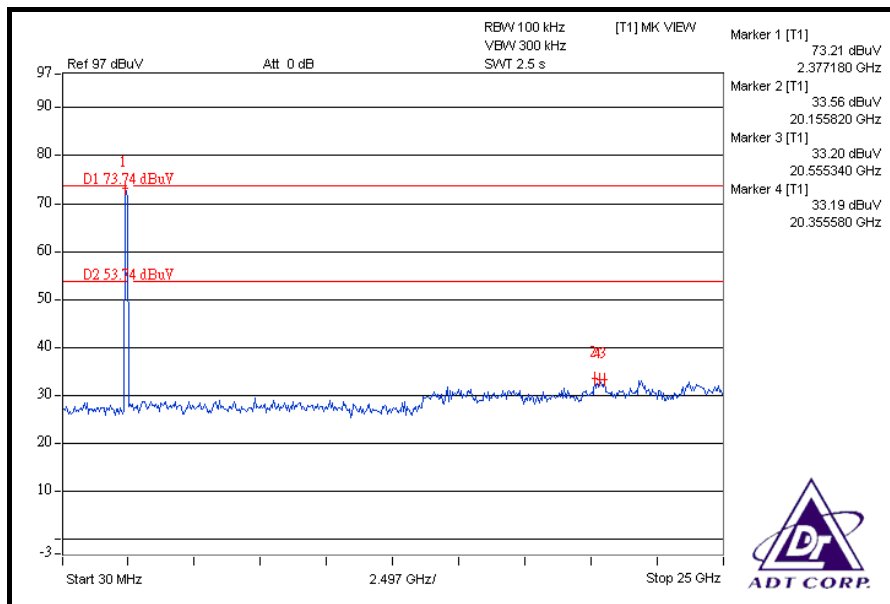

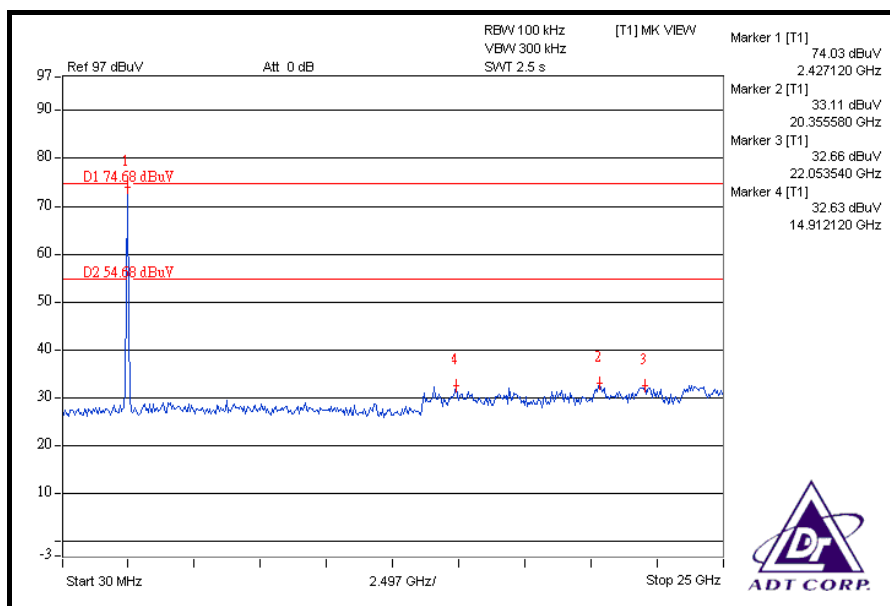
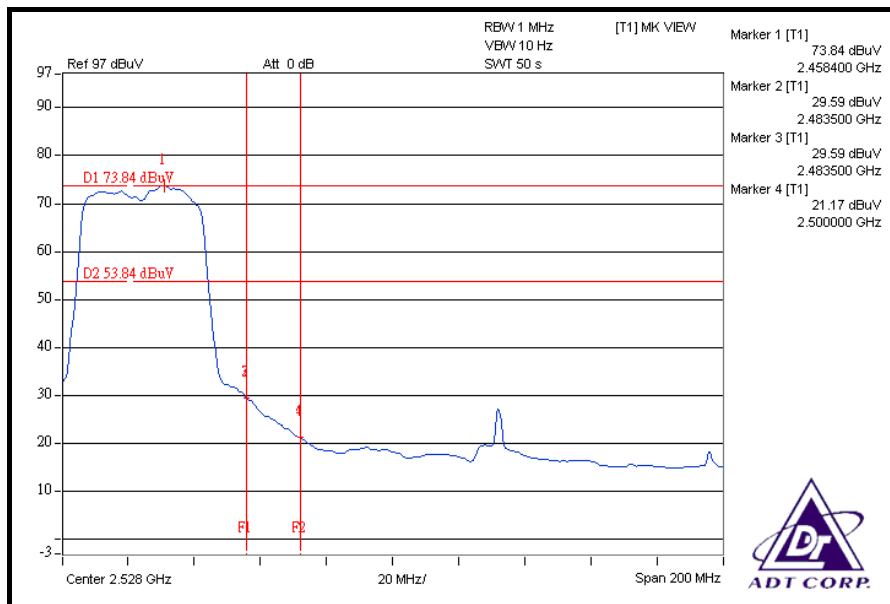



4.7 ANTENNA REQUIREMENT

4.7.1 STANDARD APPLICABLE

For intentional device, according to FCC 47 CFR Section 15.203, an intentional radiator shall be designed to ensure that no antenna other than that furnished by the responsible party shall be used with the device.

And according to FCC 47 CFR Section 15.247 (b), if transmitting antennas of directional gain greater than 6dBi are used, the power shall be reduced by the amount in dB that the directional gain of the antenna exceeds 6dBi.

4.7.2 ANTENNA CONNECTED CONSTRUCTION

The antenna used in this product is Dipole antenna with two connector types, one is without connector, and the other is R-SMA connector. The maximum gain of the antenna is 2dBi.



5. PHOTOGRAPHS OF THE TEST CONFIGURATION

Please refer to the attached file (Test Setup Photo).



6. INFORMATION ON THE TESTING LABORATORIES

We, ADT Corp., were founded in 1988 to provide our best service in EMC, Radio, Telecom and Safety consultation. Our laboratories are accredited and approved by the following approval agencies according to ISO/IEC 17025.

USA	FCC, UL
Germany	TUV Rheinland
Japan	VCCI
Norway	NEMKO
Canada	INDUSTRY CANADA , CSA
R.O.C.	TAF, BSMI, NCC
Netherlands	Telefication
Singapore	GOST-ASIA(MOU)
Russia	CERTIS(MOU)

Copies of accreditation certificates of our laboratories obtained from approval agencies can be downloaded from our web site:

www.adt.com.tw/index.5/phtml. If you have any comments, please feel free to contact us at the following:

Linko EMC/RF Lab:

Tel: 886-2-26052180

Fax: 886-2-26051924

Hsin Chu EMC/RF Lab:

Tel: 886-3-5935343

Fax: 886-3-5935342

Hwa Ya EMC/RF/Safety Telecom Lab:

Tel: 886-3-3183232

Fax: 886-3-3185050

Web Site: www.adt.com.tw

The address and road map of all our labs can be found in our web site also.

7. APPENDIX A - MODIFICATIONS RECORDERS FOR ENGINEERING CHANGES TO THE EUT BY THE LAB

No any modifications are made to the EUT by the lab during the test.

---END---