



A D T

FCC TEST REPORT

REPORT NO.: RF980324L07

MODEL NO.: EOC1650 (Refer to item 3.1 for more details)

RECEIVED: Mar. 24, 2009

TESTED: May 12 ~ Jun. 04, 2009

ISSUED: Jun. 06, 2009

APPLICANT: Senao Networks Inc.

ADDRESS: 3F, No. 529, Chung Cheng Rd., Hsintien, Taipei,
Taiwan, R.O.C.

ISSUED BY: Bureau Veritas Consumer Products Services
(H.K.) Ltd., Taoyuan Branch

LAB ADDRESS: No. 47, 14th Ling, Chia Pau Tsuen, Lin Kou
Hsiang, Taipei Hsien 244, Taiwan, R.O.C.

TEST LOCATION: No. 19, Hwa Ya 2nd Rd, Wen Hwa Tsuen, Kwei
Shan Hsiang, Taoyuan Hsien 333, Taiwan,
R.O.C.

This test report consists of 66 pages in total. It may be duplicated completely for legal use with the approval of the applicant. It should not be reproduced except in full, without the written approval of our laboratory. The client should not use it to claim product endorsement by TAF or any government agencies. The test results in the report only apply to the tested sample.





Table of Contents

1	CERTIFICATION.....	4
2	SUMMARY OF TEST RESULTS	5
2.1	MEASUREMENT UNCERTAINTY.....	5
3	GENERAL INFORMATION.....	6
3.1	GENERAL DESCRIPTION OF EUT	6
3.2	DESCRIPTION OF TEST MODES	8
3.2.1	CONFIGURATION OF SYSTEM UNDER TEST	8
3.2.2	TEST MODE APPLICABILITY AND TESTED CHANNEL DETAIL	9
3.3	GENERAL DESCRIPTION OF APPLIED STANDARDS	11
3.4	DESCRIPTION OF SUPPORT UNITS	11
4	TEST TYPES AND RESULTS	12
4.1	RADIATED EMISSION MEASUREMENT	12
4.1.1	LIMITS OF RADIATED EMISSION MEASUREMENT.....	12
4.1.2	TEST INSTRUMENTS.....	13
4.1.3	TEST PROCEDURES	14
4.1.4	DEVIATION FROM TEST STANDARD.....	14
4.1.5	TEST SETUP.....	15
4.1.6	EUT OPERATING CONDITIONS	15
4.1.7	TEST RESULTS	16
4.2	CONDUCTED EMISSION MEASUREMENT	31
4.2.1	LIMITS OF CONDUCTED EMISSION MEASUREMENT.....	31
4.2.2	TEST INSTRUMENTS.....	31
4.2.3	TEST PROCEDURES	32
4.2.4	DEVIATION FROM TEST STANDARD.....	32
4.2.5	TEST SETUP.....	33
4.2.6	EUT OPERATING CONDITIONS	33
4.2.7	TEST RESULTS	34
4.3	6dB BANDWIDTH MEASUREMENT.....	38
4.3.1	LIMITS OF 6dB BANDWIDTH MEASUREMENT	38
4.3.2	TEST INSTRUMENTS.....	38
4.3.3	TEST PROCEDURE.....	38
4.3.4	DEVIATION FROM TEST STANDARD.....	38
4.3.5	TEST SETUP.....	38
4.3.6	EUT OPERATING CONDITIONS	38
4.3.7	TEST RESULTS	39
4.4	MAXIMUM PEAK OUTPUT POWER.....	43
4.4.1	LIMITS OF MAXIMUM PEAK OUTPUT POWER MEASUREMENT	43
4.4.2	TEST INSTRUMENTS.....	43
4.4.3	TEST PROCEDURES	43
4.4.4	DEVIATION FROM TEST STANDARD.....	43
4.4.5	TEST SETUP.....	44
4.4.6	EUT OPERATING CONDITIONS	44



4.4.7	TEST RESULTS	45
4.5	POWER SPECTRAL DENSITY MEASUREMENT	46
4.5.1	LIMITS OF POWER SPECTRAL DENSITY MEASUREMENT	46
4.5.2	TEST INSTRUMENTS.....	46
4.5.3	TEST PROCEDURE.....	46
4.5.4	DEVIATION FROM TEST STANDARD.....	46
4.5.5	TEST SETUP.....	47
4.5.6	EUT OPERATING CONDITIONS	47
4.5.7	TEST RESULTS	48
4.6	BAND EDGES MEASUREMENT	52
4.6.1	LIMITS OF BAND EDGES MEASUREMENT.....	52
4.6.2	TEST INSTRUMENTS.....	52
4.6.3	TEST PROCEDURE.....	52
4.6.4	DEVIATION FROM TEST STANDARD.....	52
4.6.5	EUT OPERATING CONDITION.....	52
4.6.6	TEST RESULTS	53
4.7	ANTENNA REQUIREMENT	63
4.7.1	STANDARD APPLICABLE	63
4.7.2	ANTENNA CONNECTED CONSTRUCTION	63
5	PHOTOGRAPHS OF THE TEST CONFIGURATION.....	64
6	INFORMATION ON THE TESTING LABORATORIES	65
7	APPENDIX A – MODIFICATIONS RECORDERS FOR ENGINEERING CHANGES TO THE EUT BY THE LAB.....	66



1 CERTIFICATION

PRODUCT: Wireless AP/CB
MODEL NO.: EOC1650 (Refer to item 3.1 for more details)
BRAND: EnGenius (Refer to item 3.1 for more details)
APPLICANT: Senao Networks Inc.
TESTED: May 12 ~ Jun. 04, 2009
TEST SAMPLE: MASS-PRODUCTION
STANDARDS: **FCC Part 15, Subpart C (Section 15.247)**
ANSI C63.4-2003

The above equipment (model: EOC1650) has been tested by **Bureau Veritas Consumer Products Services (H.K.) Ltd., Taoyuan Branch**, and found compliance with the requirement of the above standards. The test record, data evaluation & Equipment Under Test (EUT) configurations represented herein are true and accurate accounts of the measurements of the sample's EMC characteristics under the conditions specified in this report.

PREPARED BY : Ivy Lin , **DATE:** Jun. 06, 2009
Ivy Lin / Specialist

TECHNICAL ACCEPTANCE : Long Chen , **DATE:** Jun. 06, 2009
Responsible for RF Long Chen / Senior Engineer

APPROVED BY : Gary Chang , **DATE:** Jun. 06, 2009
Gary Chang / Assistant Manager

2 SUMMARY OF TEST RESULTS

The EUT has been tested according to the following specifications:

APPLIED STANDARD: FCC Part 15, Subpart C			
Standard Section	Test Type and Limit	Result	Remark
15.207	AC Power Conducted Emission	PASS	Meet the requirement of limit. Minimum passing margin is -11.68dB at 0.193MHz.
15.247(a)(2)	Spectrum Bandwidth of a Direct Sequence Spread Spectrum System Limit: min. 500kHz	PASS	Meet the requirement of limit.
15.247(b)	Maximum Peak Output Power Limit: max. 30dBm	PASS	Meet the requirement of limit.
15.247(d)	Radiated Emissions Limit: Table 15.209	PASS	Meet the requirement of limit. Minimum passing margin is -1.14dB at 4824.00MHz & 68.79MHz.
15.247(e)	Power Spectral Density Limit: max. 8dBm	PASS	Meet the requirement of limit.
15.247(d)	Band Edge Measurement Limit: 20dB less than the peak value of fundamental frequency	PASS	Meet the requirement of limit.

2.1 MEASUREMENT UNCERTAINTY

Where relevant, the following measurement uncertainty levels have been estimated for tests performed on the EUT as specified in CISPR 16-4-2:

MEASUREMENT	FREQUENCY	UNCERTAINTY
Conducted emissions	150kHz~30MHz	2.44 dB
Radiated emissions	30MHz ~ 200MHz	3.19 dB
	200MHz ~1000MHz	3.21 dB
	1GHz ~ 18GHz	2.26 dB
	18GHz ~ 40GHz	1.94 dB

This uncertainty represents an expanded uncertainty expressed at approximately the 95% confidence level using a coverage factor of k=2.

3 GENERAL INFORMATION

3.1 GENERAL DESCRIPTION OF EUT

PRODUCT	Wireless AP/CB
MODEL NO.	EOC1650 (Refer to Note for more details)
FCC ID	U2M-OC1650
POWER SUPPLY	24Vdc from POE
MODULATION TYPE	CCK, DQPSK, DBPSK for DSSS 64QAM, 16QAM, QPSK, BPSK for OFDM
MODULATION TECHNOLOGY	DSSS, OFDM
TRANSFER RATE	802.11b: 11/5.5/2/1Mbps 802.11g: 54/48/36/24/18/12/9/6Mbps
OPERATING FREQUENCY	2412MHz ~ 2462MHz
NUMBER OF CHANNEL	11
MAXIMUM OUTPUT POWER	203.704mW
ANTENNA TYPE	Internal antenna: Patch antenna with 7dBi gain External antenna: Dipole antenna with 5dBi gain
DATA CABLE	NA
I/O PORTS	RJ45
ACCESSORY DEVICES	POE, adapter (for POE use)

NOTE:

1. The following models are identical to each other except their brand and model designation due to marketing requirement.

Brand	Model	Remark
EnGenius	EOC1650	Marketing requirement
	EOC1630	
HIFULL TECH	OBA6211	

2. The details of accessory devices are as below.

POE	
BRAND:	EnGenius
MODEL:	EPE-1212

Adapter (for POE use)	
BRAND:	Powertron Electronics Corp.
MODEL:	PA1015-3HU
INPUT:	100-240Vac, 50-60Hz, 0.4A
OUTPUT:	24Vdc, 0.6A, 14.4W Max
POWER LINE:	1.8m non-shielded cable without core

3. The internal and external antennas work separately. It was controlled by switched, therefore two antennas will not transmit simultaneously.
4. The EUT, operates in the 2.4GHz frequency range, lets you connect IEEE 802.11g or IEEE 802.11b devices to the network. With its high-speed data transmissions of up to 54Mbps.
5. The above EUT information was declared by manufacturer and for more detailed features description, please refer to the manufacturer's specifications or User's Manual.

3.2 DESCRIPTION OF TEST MODES

Eleven channels are provided to this EUT.

CHANNEL	FREQUENCY	CHANNEL	FREQUENCY
1	2412 MHz	7	2442 MHz
2	2417 MHz	8	2447 MHz
3	2422 MHz	9	2452 MHz
4	2427 MHz	10	2457 MHz
5	2432 MHz	11	2462 MHz
6	2437 MHz		

3.2.1 CONFIGURATION OF SYSTEM UNDER TEST

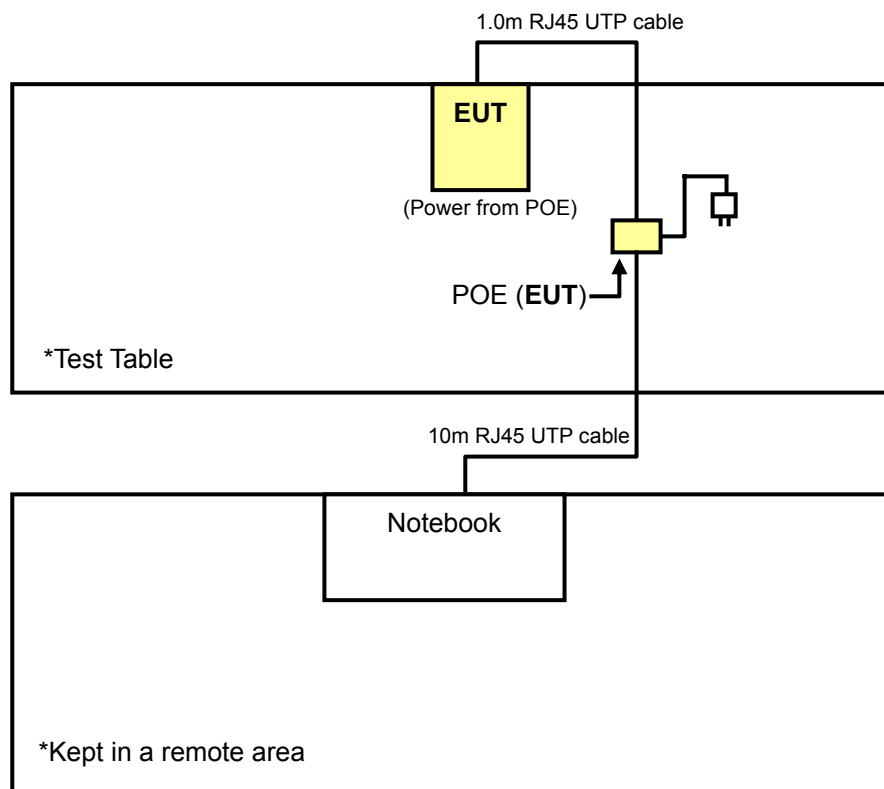

3.2.2 TEST MODE APPLICABILITY AND TESTED CHANNEL DETAIL

EUT CONFIGURE MODE	APPLICABLE TO				DESCRIPTION
	RE≥1G	RE<1G	PLC	APCM	
A	√	√	√	√	With Internal antenna
B	√	√	√	-	With External antenna

Where **RE≥1G**: Radiated Emission above 1GHz

RE<1G: Radiated Emission below 1GHz

PLC: Power Line Conducted Emission

APCM: Antenna Port Conducted Measurement

NOTE: "-" means no effect

RADIATED EMISSION TEST (ABOVE 1 GHz):

- Pre-Scan has been conducted to determine the worst-case mode from all possible combinations between available modulations, data rates, XYZ Axis and antenna ports (if EUT with antenna diversity architecture).
- Following channel(s) was (were) selected for the final test as listed below.

EUT CONFIGURE MODE	MODE	AVAILABLE CHANNEL	TESTED CHANNEL	MODULATION TECHNOLOGY	MODULATION TYPE	DATA RATE (Mbps)	AXIS
A, B	802.11b	1 to 11	1, 6, 11	DSSS	DBPSK	1	X
	802.11g	1 to 11	1, 6, 11	OFDM	BPSK	6	

RADIATED EMISSION TEST (BELOW 1 GHz):

- Pre-Scan has been conducted to determine the worst-case mode from all possible combinations between available modulations, data rates, XYZ Axis and antenna ports (if EUT with antenna diversity architecture).
- Following channel(s) was (were) selected for the final test as listed below.

EUT CONFIGURE MODE	MODE	AVAILABLE CHANNEL	TESTED CHANNEL	MODULATION TECHNOLOGY	MODULATION TYPE	DATA RATE (Mbps)	AXIS
A, B	802.11g	1 to 11	6	OFDM	BPSK	6	X

POWER LINE CONDUCTED EMISSION TEST:

- Pre-Scan has been conducted to determine the worst-case mode from all possible combinations between available modulations, data rates and antenna ports (if EUT with antenna diversity architecture).
- Following channel(s) was (were) selected for the final test as listed below.

EUT CONFIGURE MODE	MODE	AVAILABLE CHANNEL	TESTED CHANNEL	MODULATION TECHNOLOGY	MODULATION TYPE	DATA RATE (Mbps)
A, B	802.11g	1 to 11	6	OFDM	BPSK	6

BANDEDGE MEASUREMENT:

- Pre-Scan has been conducted to determine the worst-case mode from all possible combinations between available modulations, data rates and antenna ports (if EUT with antenna diversity architecture).
- Following channel(s) was (were) selected for the final test as listed below.

EUT CONFIGURE MODE	MODE	AVAILABLE CHANNEL	TESTED CHANNEL	MODULATION TECHNOLOGY	MODULATION TYPE	DATA RATE (Mbps)
A, B	802.11b	1 to 11	1, 11	DSSS	DBPSK	1
	802.11g	1 to 11	1, 11	OFDM	BPSK	6

ANTENNA PORT CONDUCTED MEASUREMENT:

- Pre-Scan has been conducted to determine the worst-case mode from all possible combinations between available modulations, data rates and antenna ports (if EUT with antenna diversity architecture).
- Following channel(s) was (were) selected for the final test as listed below.

EUT CONFIGURE MODE	MODE	AVAILABLE CHANNEL	TESTED CHANNEL	MODULATION TECHNOLOGY	MODULATION TYPE	DATA RATE (Mbps)
A	802.11b	1 to 11	1, 6, 11	DSSS	DBPSK	1
	802.11g	1 to 11	1, 6, 11	OFDM	BPSK	6

3.3 GENERAL DESCRIPTION OF APPLIED STANDARDS

The EUT is a RF product. According to the specifications of the manufacturer, it must comply with the requirements of the following standards:

FCC Part 15, Subpart C (15.247)

ANSI C63.4- 2003

All test items have been performed and recorded as per the above standards.

NOTE: The EUT is also considered as a kind of computer peripheral, because the connection to computer is necessary for typical use. It has been verified to comply with the requirements of FCC Part 15, Subpart B, Class B (DoC). The test report has been issued separately.

3.4 DESCRIPTION OF SUPPORT UNITS

The EUT has been tested as an independent unit together with other necessary accessories or support units. The following support units or accessories were used to form a representative test configuration during the tests.

NO.	PRODUCT	BRAND	MODEL NO.	SERIAL NO.	FCC ID
1	NOTEBOOK	DELL	PP05L	9954115984	E2K24CLNS

NO.	SIGNAL CABLE DESCRIPTION OF THE ABOVE SUPPORT UNITS
1	10m UTP RJ45 cable

NOTE: 1. All power cords of the above support units are non shielded (1.8m).
2. Item 1 acted as a communication partner to transfer data.

4 TEST TYPES AND RESULTS

4.1 RADIATED EMISSION MEASUREMENT

4.1.1 LIMITS OF RADIATED EMISSION MEASUREMENT

Emissions radiated outside of the specified bands, shall be according to the general radiated limits in 15.209 as following:

Frequencies (MHz)	Field strength (microvolts/meter)	Measurement distance (meters)
0.009-0.490	2400/F(kHz)	300
0.490-1.705	24000/F(kHz)	30
1.705-30.0	30	30
30-88	100	3
88-216	150	3
216-960	200	3
Above 960	500	3

NOTE:

1. The lower limit shall apply at the transition frequencies.
2. Emission level (dBuV/m) = 20 log Emission level (uV/m).
3. As shown in 15.35(b), for frequencies above 1000MHz, the field strength limits are based on average detector, however, the peak field strength of any emission shall not exceed the maximum permitted average limits, specified above by more than 20dB under any condition of modulation.

4.1.2 TEST INSTRUMENTS

DESCRIPTION & MANUFACTURER	MODEL NO.	SERIAL NO.	DATE OF CALIBRATION	DUE DATE OF CALIBRATION
Test Receiver ROHDE & SCHWARZ	ESI7	100033	Jun. 30, 2008	Jun. 29, 2009
Spectrum Analyzer ROHDE & SCHWARZ	FSP40	100040	Jul. 04, 2008	Jul. 03, 2009
BILOG Antenna SCHWARZBECK	VULB9168	9168-160	Apr. 27, 2009	Apr. 26, 2010
HORN Antenna SCHWARZBECK	9120D	9120D-209	Jun. 24, 2008	Jun. 23, 2009
HORN Antenna SCHWARZBECK	BBHA 9170	BBHA9170243	Dec. 25, 2008	Dec. 24, 2009
Preamplifier Agilent	8447D	2944A10633	Nov. 03, 2008	Nov. 02, 2009
Preamplifier Agilent	8449B	3008A01964	Oct. 23, 2008	Oct. 22, 2009
RF signal cable HUBER+SUHNNER	SUCOFLEX 104	238141/4	May 13, 2009	May 12, 2010
RF signal cable HUBER+SUHNNER	SUCOFLEX 104	12738/6	May 13, 2009	May 12, 2010
Software ADT.	ADT_Radiated_ V7.6.15.9.2	NA	NA	NA
Antenna Tower inn-co GmbH	MA 4000	013303	NA	NA
Antenna Tower Controller inn-co GmbH	CO2000	017303	NA	NA
Turn Table ADT.	TT100.	TT93021703	NA	NA
Turn Table Controller ADT.	SC100.	SC93021703	NA	NA

- NOTE:**
1. The calibration interval of the above test instruments is 12 months and the calibrations are traceable to NML/ROC and NIST/USA.
 2. The test was performed in HwaYa Chamber 3.
 3. The horn antenna and HP preamplifier (model: 8449B) are used only for the measurement of emission frequency above 1GHz if tested.
 4. The FCC Site Registration No. is 988962.
 5. The IC Site Registration No. is IC 7450F-3.

4.1.3 TEST PROCEDURES

- a. The EUT was placed on the top of a rotating table 0.8 meters above the ground at a 3 meters semi-anechoic chamber. The table was rotated 360 degrees to determine the position of the highest radiation.
- b. The EUT was set 3 meters away from the interference-receiving antenna, which was mounted on the top of a variable-height antenna tower.
- c. The antenna is a broadband antenna, and its height is varied from one meter to four meters above the ground to determine the maximum value of the field strength. Both horizontal and vertical polarizations of the antenna are set to make the measurement.
- d. For each suspected emission, the EUT was arranged to its worst case and then the antenna was tuned to heights from 1 meter to 4 meters and the rotatable table was turned from 0 degrees to 360 degrees to find the maximum reading.
- e. The test-receiver system was set to Peak Detect Function and Specified Bandwidth with Maximum Hold Mode.
- f. If the emission level of the EUT in peak mode was lower than the limit specified, then testing could be stopped and the peak values of the EUT would be reported. Otherwise the emissions would be re-tested one by one using peak, quasi-peak method or average method as specified and then reported in data sheet.

NOTE:

1. The resolution bandwidth and video bandwidth of test receiver/spectrum analyzer is 120kHz for Peak detection (PK) and Quasi-peak detection (QP) at frequency below 1GHz.
2. The resolution bandwidth of test receiver/spectrum analyzer is 1 MHz and video bandwidth is 3MHz for Peak detection at frequency above 1GHz.
3. The resolution bandwidth of test receiver/spectrum analyzer is 1 MHz and the video bandwidth is 10 Hz for Average detection (AV) at frequency above 1GHz.
4. All modes of operation were investigated and the worst-case emissions are reported.

4.1.4 DEVIATION FROM TEST STANDARD

No deviation.

4.1.5 TEST SETUP

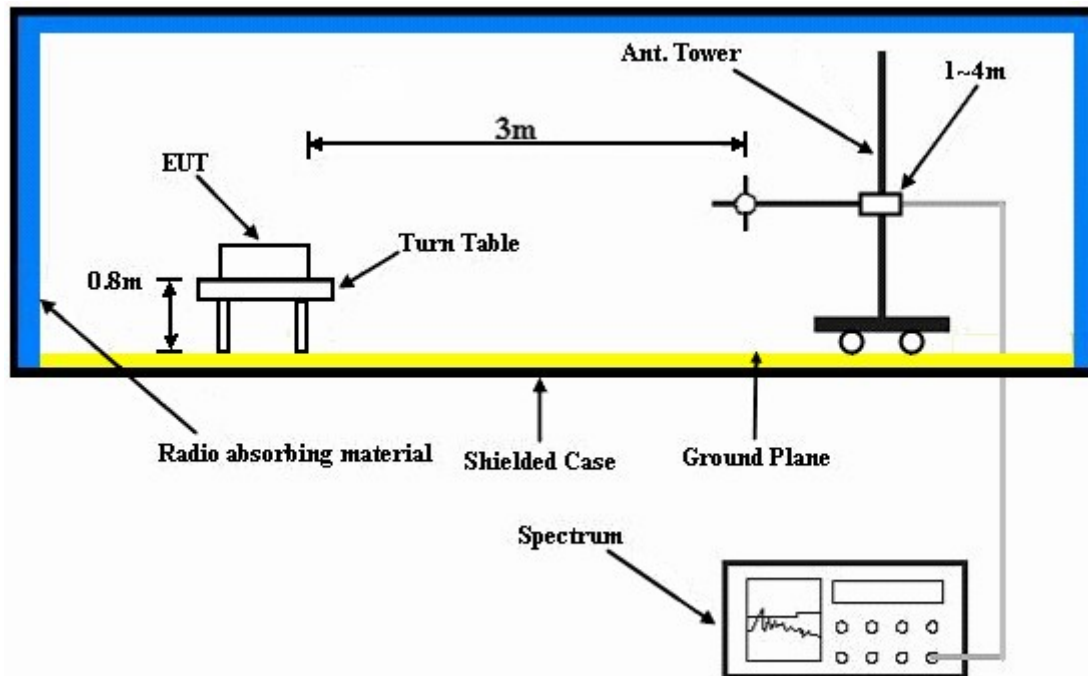

For the actual test configuration, please refer to the attached file (Test Setup Photo).

4.1.6 EUT OPERATING CONDITIONS

- a. Placed the EUT on the testing table.
- b. Prepared the notebook system outside of testing area to act as communication partners.
- c. The communication partner connected with EUT via a RJ45 UTP cable and run a test program (provided by manufacturer) to enable EUT under transmission condition continuously at specific channel frequency.
- d. The communication partner sent data to EUT by command "PING".

4.1.7 TEST RESULTS

802.11b DSSS MODULATION

EUT TEST CONDITION		MEASUREMENT DETAIL	
CHANNEL	Channel 1	FREQUENCY RANGE	1 ~ 25GHz
INPUT POWER (SYSTEM)	120Vac, 60 Hz	DETECTOR FUNCTION	Peak (PK) Average (AV)
ENVIRONMENTAL CONDITIONS	25.0deg. C, 65.0%RH 1005hPa	TESTED BY	Antony Lee
TEST MODE	A		

ANTENNA POLARITY & TEST DISTANCE: HORIZONTAL AT 3 M								
NO.	FREQ. (MHz)	EMISSION LEVEL (dBuV/m)	LIMIT (dBuV/m)	MARGIN (dB)	ANTENNA HEIGHT (m)	TABLE ANGLE (Degree)	RAW VALUE (dBuV)	CORRECTION FACTOR (dB/m)
1	2390.00	61.05 PK	74.00	-12.95	1.31 H	87	28.61	32.44
2	2390.00	51.40 AV	54.00	-2.60	1.31 H	87	18.96	32.44
3	*2412.00	114.89 PK			1.98 H	76	82.37	32.52
4	*2412.00	109.81 AV			1.98 H	76	77.29	32.52
5	4824.00	56.38 PK	74.00	-17.62	1.35 H	344	18.08	38.30
6	4824.00	52.86 AV	54.00	-1.14	1.35 H	344	14.56	38.30
7	#9648.00	76.40 PK	94.89	-18.49	1.01 H	165	28.15	48.25
8	#9648.00	75.70 AV	89.81	-14.11	1.01 H	165	27.45	48.25
ANTENNA POLARITY & TEST DISTANCE: VERTICAL AT 3 M								
NO.	FREQ. (MHz)	EMISSION LEVEL (dBuV/m)	LIMIT (dBuV/m)	MARGIN (dB)	ANTENNA HEIGHT (m)	TABLE ANGLE (Degree)	RAW VALUE (dBuV)	CORRECTION FACTOR (dB/m)
1	2390.00	56.13 PK	74.00	-17.87	1.86 V	133	23.69	32.44
2	2390.00	45.21 AV	54.00	-8.79	1.86 V	133	12.77	32.44
3	*2412.00	104.82 PK			1.91 V	135	72.30	32.52
4	*2412.00	99.71 AV			1.91 V	135	67.19	32.52
5	4824.00	56.42 PK	74.00	-17.58	1.00 V	22	18.12	38.30
6	4824.00	52.80 AV	54.00	-1.20	1.00 V	22	14.50	38.30
7	#9648.00	74.05 PK	84.82	-10.77	1.00 V	105	25.80	48.25
8	#9648.00	73.02 AV	79.71	-6.69	1.00 V	105	24.77	48.25

- REMARKS:**
1. Emission level (dBuV/m) = Raw Value (dBuV) + Correction Factor (dB/m).
 2. Correction Factor (dB/m) = Antenna Factor (dB/m) + Cable Factor (dB).
 3. The other emission levels were very low against the limit.
 4. Margin value = Emission level – Limit value.
 5. “ * “: Fundamental frequency.
 6. “#”:The radiated frequency is out the restricted band.



EUT TEST CONDITION		MEASUREMENT DETAIL	
CHANNEL	Channel 6	FREQUENCY RANGE	1 ~ 25GHz
INPUT POWER (SYSTEM)	120Vac, 60 Hz	DETECTOR FUNCTION	Peak (PK) Average (AV)
ENVIRONMENTAL CONDITIONS	25.0deg. C, 65.0%RH 1005hPa	TESTED BY	Antony Lee
TEST MODE	A		

ANTENNA POLARITY & TEST DISTANCE: HORIZONTAL AT 3 M

NO.	FREQ. (MHz)	EMISSION LEVEL (dBuV/m)	LIMIT (dBuV/m)	MARGIN (dB)	ANTENNA HEIGHT (m)	TABLE ANGLE (Degree)	RAW VALUE (dBuV)	CORRECTION FACTOR (dB/m)
1	*2437.00	113.81 PK			1.26 H	89	81.21	32.60
2	*2437.00	108.75 AV			1.26 H	89	76.15	32.60
3	4874.00	56.14 PK	74.00	-17.86	1.32 H	142	17.64	38.50
4	4874.00	52.26 AV	54.00	-1.74	1.32 H	142	13.76	38.50
5	7311.00	56.37 PK	74.00	-17.63	1.33 H	341	11.89	44.48
6	7311.00	47.21 AV	54.00	-6.79	1.33 H	341	2.73	44.48
7	#9748.00	72.36 PK	93.81	-21.45	1.07 H	164	23.96	48.40
8	#9748.00	71.43 AV	88.75	-17.32	1.07 H	164	23.03	48.40

ANTENNA POLARITY & TEST DISTANCE: VERTICAL AT 3 M

NO.	FREQ. (MHz)	EMISSION LEVEL (dBuV/m)	LIMIT (dBuV/m)	MARGIN (dB)	ANTENNA HEIGHT (m)	TABLE ANGLE (Degree)	RAW VALUE (dBuV)	CORRECTION FACTOR (dB/m)
1	*2437.00	103.63 PK			1.00 V	181	71.03	32.60
2	*2437.00	98.55 AV			1.00 V	181	65.95	32.60
3	4874.00	54.89 PK	74.00	-19.11	1.04 V	44	16.39	38.50
4	4874.00	50.89 AV	54.00	-3.11	1.04 V	44	12.39	38.50
5	7311.00	58.09 PK	74.00	-15.91	1.72 V	263	13.61	44.48
6	7311.00	49.64 AV	54.00	-4.36	1.72 V	263	5.16	44.48
7	#9748.00	73.92 PK	83.63	-9.71	1.00 V	44	25.52	48.40
8	#9748.00	72.25 AV	78.55	-6.30	1.00 V	44	23.85	48.40

- REMARKS:**
1. Emission level (dBuV/m) = Raw Value (dBuV) + Correction Factor (dB/m).
 2. Correction Factor (dB/m) = Antenna Factor (dB/m) + Cable Factor (dB).
 3. The other emission levels were very low against the limit.
 4. Margin value = Emission level – Limit value.
 5. “ * “: Fundamental frequency.
 6. “#”:The radiated frequency is out the restricted band.



A D T

EUT TEST CONDITION		MEASUREMENT DETAIL	
CHANNEL	Channel 11	FREQUENCY RANGE	1 ~ 25GHz
INPUT POWER (SYSTEM)	120Vac, 60 Hz	DETECTOR FUNCTION	Peak (PK) Average (AV)
ENVIRONMENTAL CONDITIONS	25.0deg. C, 65.0%RH 1005hPa	TESTED BY	Antony Lee
TEST MODE	A		

ANTENNA POLARITY & TEST DISTANCE: HORIZONTAL AT 3 M								
NO.	FREQ. (MHz)	EMISSION LEVEL (dBuV/m)	LIMIT (dBuV/m)	MARGIN (dB)	ANTENNA HEIGHT (m)	TABLE ANGLE (Degree)	RAW VALUE (dBuV)	CORRECTION FACTOR (dB/m)
1	*2462.00	113.00 PK			1.30 H	80	80.32	32.68
2	*2462.00	108.29 AV			1.30 H	80	75.61	32.68
3	2483.50	58.83 PK	74.00	-15.17	1.65 H	74	26.07	32.76
4	2483.50	48.61 AV	54.00	-5.39	1.65 H	74	15.85	32.76
5	4924.00	57.19 PK	74.00	-16.81	1.17 H	143	18.55	38.64
6	4924.00	52.46 AV	54.00	-1.54	1.17 H	143	13.82	38.64
7	7386.00	61.12 PK	74.00	-12.88	1.32 H	129	16.49	44.63
8	7386.00	52.23 AV	54.00	-1.77	1.32 H	129	7.60	44.63
9	#9848.00	73.73 PK	93.00	-19.27	1.01 H	170	25.24	48.49
10	#9848.00	73.23 AV	88.29	-15.06	1.01 H	170	24.74	48.49

ANTENNA POLARITY & TEST DISTANCE: VERTICAL AT 3 M								
NO.	FREQ. (MHz)	EMISSION LEVEL (dBuV/m)	LIMIT (dBuV/m)	MARGIN (dB)	ANTENNA HEIGHT (m)	TABLE ANGLE (Degree)	RAW VALUE (dBuV)	CORRECTION FACTOR (dB/m)
1	*2462.00	103.22 PK			1.02 V	161	70.54	32.68
2	*2462.00	98.13 AV			1.02 V	161	65.45	32.68
3	2483.50	56.09 PK	74.00	-17.91	1.02 V	96	23.33	32.76
4	2483.50	45.55 AV	54.00	-8.45	1.02 V	96	12.79	32.76
5	4924.00	54.97 PK	74.00	-19.03	1.06 V	2	16.33	38.64
6	4924.00	50.82 AV	54.00	-3.18	1.06 V	2	12.18	38.64
7	7386.00	58.00 PK	74.00	-16.00	1.00 V	150	13.37	44.63
8	7386.00	50.86 AV	54.00	-3.14	1.00 V	150	6.23	44.63
9	#9848.00	76.20 PK	83.22	-7.02	1.00 V	57	27.71	48.49
10	#9848.00	74.30 AV	78.13	-3.83	1.00 V	57	25.81	48.49

- REMARKS:**
1. Emission level (dBuV/m) = Raw Value (dBuV) + Correction Factor (dB/m).
 2. Correction Factor (dB/m) = Antenna Factor (dB/m) + Cable Factor (dB).
 3. The other emission levels were very low against the limit.
 4. Margin value = Emission level – Limit value.
 5. “ * “: Fundamental frequency.
 6. “#“: The radiated frequency is out the restricted band.



A D T

EUT TEST CONDITION		MEASUREMENT DETAIL	
CHANNEL	Channel 1	FREQUENCY RANGE	1 ~ 25GHz
INPUT POWER (SYSTEM)	120Vac, 60 Hz	DETECTOR FUNCTION	Peak (PK) Average (AV)
ENVIRONMENTAL CONDITIONS	25.0deg. C, 65.0%RH 1005hPa	TESTED BY	Antony Lee
TEST MODE	B		

ANTENNA POLARITY & TEST DISTANCE: HORIZONTAL AT 3 M								
NO.	FREQ. (MHz)	EMISSION LEVEL (dBuV/m)	LIMIT (dBuV/m)	MARGIN (dB)	ANTENNA HEIGHT (m)	TABLE ANGLE (Degree)	RAW VALUE (dBuV)	CORRECTION FACTOR (dB/m)
1	2390.00	56.96 PK	74.00	-17.04	1.33 H	68	24.52	32.44
2	2390.00	47.30 AV	54.00	-6.70	1.33 H	68	14.86	32.44
3	*2412.00	111.65 PK			1.34 H	64	79.13	32.52
4	*2412.00	106.54 AV			1.34 H	64	74.02	32.52
5	4824.00	56.54 PK	74.00	-17.46	1.10 H	145	18.24	38.30
6	4824.00	52.32 AV	54.00	-1.68	1.10 H	145	14.02	38.30
7	#9648.00	73.48 PK	91.65	-18.17	1.17 H	169	25.23	48.25
8	#9648.00	71.72 AV	86.54	-14.82	1.17 H	169	23.47	48.25
ANTENNA POLARITY & TEST DISTANCE: VERTICAL AT 3 M								
NO.	FREQ. (MHz)	EMISSION LEVEL (dBuV/m)	LIMIT (dBuV/m)	MARGIN (dB)	ANTENNA HEIGHT (m)	TABLE ANGLE (Degree)	RAW VALUE (dBuV)	CORRECTION FACTOR (dB/m)
1	2390.00	56.23 PK	74.00	-17.77	1.02 V	6	23.79	32.44
2	2390.00	45.23 AV	54.00	-8.77	1.02 V	6	12.79	32.44
3	*2412.00	97.56 PK			1.00 V	2	65.04	32.52
4	*2412.00	92.44 AV			1.00 V	2	59.92	32.52
5	4824.00	54.57 PK	74.00	-19.43	1.00 V	269	16.27	38.30
6	4824.00	51.12 AV	54.00	-2.88	1.00 V	269	12.82	38.30
7	#9648.00	71.65 PK	77.56	-5.91	1.00 V	175	23.40	48.25
8	#9648.00	70.45 AV	72.44	-1.99	1.00 V	175	22.20	48.25

- REMARKS:**
1. Emission level (dBuV/m) = Raw Value (dBuV) + Correction Factor (dB/m).
 2. Correction Factor (dB/m) = Antenna Factor (dB/m) + Cable Factor (dB).
 3. The other emission levels were very low against the limit.
 4. Margin value = Emission level – Limit value.
 5. “ * “: Fundamental frequency.
 6. “#”: The radiated frequency is out the restricted band.



A D T

EUT TEST CONDITION		MEASUREMENT DETAIL	
CHANNEL	Channel 6	FREQUENCY RANGE	1 ~ 25GHz
INPUT POWER (SYSTEM)	120Vac, 60 Hz	DETECTOR FUNCTION	Peak (PK) Average (AV)
ENVIRONMENTAL CONDITIONS	25.0deg. C, 65.0%RH 1005hPa	TESTED BY	Antony Lee
TEST MODE	B		

ANTENNA POLARITY & TEST DISTANCE: HORIZONTAL AT 3 M								
NO.	FREQ. (MHz)	EMISSION LEVEL (dBuV/m)	LIMIT (dBuV/m)	MARGIN (dB)	ANTENNA HEIGHT (m)	TABLE ANGLE (Degree)	RAW VALUE (dBuV)	CORRECTION FACTOR (dB/m)
1	*2437.00	110.79 PK			1.29 H	66	78.19	32.60
2	*2437.00	105.56 AV			1.29 H	66	72.96	32.60
3	4874.00	55.91 PK	74.00	-18.09	1.00 H	338	17.41	38.50
4	4874.00	52.23 AV	54.00	-1.77	1.00 H	338	13.73	38.50
5	7311.00	57.51 PK	74.00	-16.49	1.00 H	196	13.03	44.48
6	7311.00	50.56 AV	54.00	-3.44	1.00 H	196	6.08	44.48
7	#9748.00	71.34 PK	90.79	-19.45	1.00 H	12	22.94	48.40
8	#9748.00	69.15 AV	85.56	-16.41	1.00 H	12	20.75	48.40
ANTENNA POLARITY & TEST DISTANCE: VERTICAL AT 3 M								
NO.	FREQ. (MHz)	EMISSION LEVEL (dBuV/m)	LIMIT (dBuV/m)	MARGIN (dB)	ANTENNA HEIGHT (m)	TABLE ANGLE (Degree)	RAW VALUE (dBuV)	CORRECTION FACTOR (dB/m)
1	*2437.00	96.39 PK			1.22 V	349	63.79	32.60
2	*2437.00	91.32 AV			1.22 V	349	58.72	32.60
3	4874.00	54.08 PK	74.00	-19.92	1.00 V	207	15.58	38.50
4	4874.00	50.25 AV	54.00	-3.75	1.00 V	207	11.75	38.50
5	7311.00	57.09 PK	74.00	-16.91	1.00 V	211	12.61	44.48
6	7311.00	48.64 AV	54.00	-5.36	1.00 V	211	4.16	44.48
7	#9748.00	69.42 PK	76.39	-6.97	1.00 V	18	21.02	48.40
8	#9748.00	66.03 AV	71.32	-5.29	1.00 V	18	17.63	48.40

- REMARKS:**
1. Emission level (dBuV/m) = Raw Value (dBuV) + Correction Factor (dB/m).
 2. Correction Factor (dB/m) = Antenna Factor (dB/m) + Cable Factor (dB).
 3. The other emission levels were very low against the limit.
 4. Margin value = Emission level – Limit value.
 5. “ * “: Fundamental frequency.
 6. “#”:The radiated frequency is out the restricted band.



EUT TEST CONDITION		MEASUREMENT DETAIL	
CHANNEL	Channel 11	FREQUENCY RANGE	1 ~ 25GHz
INPUT POWER (SYSTEM)	120Vac, 60 Hz	DETECTOR FUNCTION	Peak (PK) Average (AV)
ENVIRONMENTAL CONDITIONS	25.0deg. C, 65.0%RH 1005hPa	TESTED BY	Antony Lee
TEST MODE	B		

ANTENNA POLARITY & TEST DISTANCE: HORIZONTAL AT 3 M								
NO.	FREQ. (MHz)	EMISSION LEVEL (dBuV/m)	LIMIT (dBuV/m)	MARGIN (dB)	ANTENNA HEIGHT (m)	TABLE ANGLE (Degree)	RAW VALUE (dBuV)	CORRECTION FACTOR (dB/m)
1	*2462.00	111.33 PK			1.28 H	67	78.65	32.68
2	*2462.00	106.24 AV			1.28 H	67	73.56	32.68
3	2483.50	56.58 PK	74.00	-17.42	1.00 H	263	23.82	32.76
4	2483.50	45.58 AV	54.00	-8.42	1.00 H	263	12.82	32.76
5	4924.00	55.46 PK	74.00	-18.54	1.05 H	147	16.82	38.64
6	4924.00	52.53 AV	54.00	-1.47	1.05 H	147	13.89	38.64
7	7386.00	58.08 PK	74.00	-15.92	1.00 H	192	13.45	44.63
8	7386.00	49.09 AV	54.00	-4.91	1.00 H	192	4.46	44.63
9	#9848.00	68.21 PK	91.33	-23.12	1.00 H	13	19.72	48.49
10	#9848.00	66.03 AV	86.24	-20.21	1.00 H	13	17.54	48.49

- REMARKS:**
1. Emission level (dBuV/m) = Raw Value (dBuV) + Correction Factor (dB/m).
 2. Correction Factor (dB/m) = Antenna Factor (dB/m) + Cable Factor (dB).
 3. The other emission levels were very low against the limit.
 4. Margin value = Emission level – Limit value.
 5. “ * “: Fundamental frequency.
 6. “#”:The radiated frequency is out the restricted band.



A D T

EUT TEST CONDITION		MEASUREMENT DETAIL	
CHANNEL	Channel 11	FREQUENCY RANGE	1 ~ 25GHz
INPUT POWER (SYSTEM)	120Vac, 60 Hz	DETECTOR FUNCTION	Peak (PK) Average (AV)
ENVIRONMENTAL CONDITIONS	25.0deg. C, 65.0%RH 1005hPa	TESTED BY	Antony Lee
TEST MODE	B		

ANTENNA POLARITY & TEST DISTANCE: VERTICAL AT 3 M								
NO.	FREQ. (MHz)	EMISSION LEVEL (dBuV/m)	LIMIT (dBuV/m)	MARGIN (dB)	ANTENNA HEIGHT (m)	TABLE ANGLE (Degree)	RAW VALUE (dBuV)	CORRECTION FACTOR (dB/m)
1	*2462.00	97.31 PK			1.97 V	347	64.63	32.68
2	*2462.00	92.18 AV			1.97 V	347	59.50	32.68
3	2483.50	55.79 PK	74.00	-18.21	1.02 V	63	23.03	32.76
4	2483.50	45.83 AV	54.00	-8.17	1.02 V	63	13.07	32.76
5	4924.00	54.45 PK	74.00	-19.55	1.00 V	267	15.81	38.64
6	4924.00	50.47 AV	54.00	-3.53	1.00 V	267	11.83	38.64
7	7386.00	57.20 PK	74.00	-16.80	1.00 V	182	12.57	44.63
8	7386.00	48.64 AV	54.00	-5.36	1.00 V	182	4.01	44.63
9	#9848.00	68.69 PK	77.31	-8.62	1.00 V	287	20.20	48.49
10	#9848.00	66.66 AV	72.18	-5.52	1.00 V	287	18.17	48.49

- REMARKS:**
1. Emission level (dBuV/m) = Raw Value (dBuV) + Correction Factor (dB/m).
 2. Correction Factor (dB/m) = Antenna Factor (dB/m) + Cable Factor (dB).
 3. The other emission levels were very low against the limit.
 4. Margin value = Emission level – Limit value.
 5. “ * “: Fundamental frequency.
 6. “#”:The radiated frequency is out the restricted band.

802.11g OFDM MODULATION

EUT TEST CONDITION		MEASUREMENT DETAIL	
CHANNEL	Channel 1	FREQUENCY RANGE	1 ~ 25GHz
INPUT POWER (SYSTEM)	120Vac, 60 Hz	DETECTOR FUNCTION	Peak (PK) Average (AV)
ENVIRONMENTAL CONDITIONS	24.0deg. C, 64.0%RH 1005hPa	TESTED BY	Brad Wu
TEST MODE	A		

ANTENNA POLARITY & TEST DISTANCE: HORIZONTAL AT 3 M								
NO.	FREQ. (MHz)	EMISSION LEVEL (dBuV/m)	LIMIT (dBuV/m)	MARGIN (dB)	ANTENNA HEIGHT (m)	TABLE ANGLE (Degree)	RAW VALUE (dBuV)	CORRECTION FACTOR (dB/m)
1	2390.00	67.88 PK	74.00	-6.12	1.31 H	282	35.44	32.44
2	2390.00	52.85 AV	54.00	-1.15	1.31 H	282	20.41	32.44
3	*2412.00	116.82 PK			1.34 H	259	84.30	32.52
4	*2412.00	106.63 AV			1.34 H	259	74.11	32.52
5	4824.00	50.84 PK	74.00	-23.16	1.04 H	216	12.54	38.30
6	4824.00	37.98 AV	54.00	-16.02	1.04 H	216	-0.32	38.30
ANTENNA POLARITY & TEST DISTANCE: VERTICAL AT 3 M								
NO.	FREQ. (MHz)	EMISSION LEVEL (dBuV/m)	LIMIT (dBuV/m)	MARGIN (dB)	ANTENNA HEIGHT (m)	TABLE ANGLE (Degree)	RAW VALUE (dBuV)	CORRECTION FACTOR (dB/m)
1	2390.00	58.30 PK	74.00	-15.70	1.40 V	189	25.86	32.44
2	2390.00	47.30 AV	54.00	-6.70	1.40 V	189	14.86	32.44
3	*2412.00	106.56 PK			1.40 V	189	74.04	32.52
4	*2412.00	96.40 AV			1.40 V	189	63.88	32.52
5	4824.00	50.61 PK	74.00	-23.39	1.03 V	256	12.31	38.30
6	4824.00	37.74 AV	54.00	-16.26	1.03 V	256	-0.56	38.30

- REMARKS:**
1. Emission level (dBuV/m) = Raw Value (dBuV) + Correction Factor (dB/m).
 2. Correction Factor (dB/m) = Antenna Factor (dB/m) + Cable Factor (dB).
 3. The other emission levels were very low against the limit.
 4. Margin value = Emission level – Limit value.
 5. “ * “: Fundamental frequency.



EUT TEST CONDITION		MEASUREMENT DETAIL	
CHANNEL	Channel 6	FREQUENCY RANGE	1 ~ 25GHz
INPUT POWER (SYSTEM)	120Vac, 60 Hz	DETECTOR FUNCTION	Peak (PK) Average (AV)
ENVIRONMENTAL CONDITIONS	24.0deg. C, 64.0%RH 1005hPa	TESTED BY	Brad Wu
TEST MODE	A		

ANTENNA POLARITY & TEST DISTANCE: HORIZONTAL AT 3 M								
NO.	FREQ. (MHz)	EMISSION LEVEL (dBuV/m)	LIMIT (dBuV/m)	MARGIN (dB)	ANTENNA HEIGHT (m)	TABLE ANGLE (Degree)	RAW VALUE (dBuV)	CORRECTION FACTOR (dB/m)
1	*2437.00	116.62 PK			1.31 H	258	84.02	32.60
2	*2437.00	106.38 AV			1.31 H	258	73.78	32.60
3	4874.00	54.98 PK	74.00	-19.02	1.00 H	178	16.48	38.50
4	4874.00	41.58 AV	54.00	-12.42	1.00 H	178	3.08	38.50
5	7311.00	61.95 PK	74.00	-12.05	1.42 H	174	17.47	44.48
6	7311.00	47.92 AV	54.00	-6.08	1.42 H	174	3.44	44.48
7	#9748.00	68.87 PK	96.62	-27.75	1.38 H	151	20.47	48.40
8	#9748.00	54.47 AV	86.38	-31.91	1.38 H	151	6.07	48.40
ANTENNA POLARITY & TEST DISTANCE: VERTICAL AT 3 M								
NO.	FREQ. (MHz)	EMISSION LEVEL (dBuV/m)	LIMIT (dBuV/m)	MARGIN (dB)	ANTENNA HEIGHT (m)	TABLE ANGLE (Degree)	RAW VALUE (dBuV)	CORRECTION FACTOR (dB/m)
1	*2437.00	106.11 PK			1.41 V	192	73.51	32.60
2	*2437.00	96.02 AV			1.41 V	192	63.42	32.60
3	4874.00	54.26 PK	74.00	-19.74	1.14 V	251	15.76	38.50
4	4874.00	40.83 AV	54.00	-13.17	1.14 V	251	2.33	38.50
5	7311.00	62.73 PK	74.00	-11.27	1.44 V	294	18.25	44.48
6	7311.00	49.60 AV	54.00	-4.40	1.44 V	294	5.12	44.48
7	#9748.00	71.99 PK	86.11	-14.12	1.34 V	257	23.59	48.40
8	#9748.00	57.16 AV	76.02	-18.86	1.34 V	257	8.76	48.40

- REMARKS:**
1. Emission level (dBuV/m) = Raw Value (dBuV) + Correction Factor (dB/m).
 2. Correction Factor (dB/m) = Antenna Factor (dB/m) + Cable Factor (dB).
 3. The other emission levels were very low against the limit.
 4. Margin value = Emission level – Limit value.
 5. “ * “: Fundamental frequency.
 6. “#“: The radiated frequency is out the restricted band.



A D T

EUT TEST CONDITION		MEASUREMENT DETAIL	
CHANNEL	Channel 11	FREQUENCY RANGE	1 ~ 25GHz
INPUT POWER (SYSTEM)	120Vac, 60 Hz	DETECTOR FUNCTION	Peak (PK) Average (AV)
ENVIRONMENTAL CONDITIONS	24.0deg. C, 64.0%RH 1005hPa	TESTED BY	Brad Wu
TEST MODE	A		

ANTENNA POLARITY & TEST DISTANCE: HORIZONTAL AT 3 M								
NO.	FREQ. (MHz)	EMISSION LEVEL (dBuV/m)	LIMIT (dBuV/m)	MARGIN (dB)	ANTENNA HEIGHT (m)	TABLE ANGLE (Degree)	RAW VALUE (dBuV)	CORRECTION FACTOR (dB/m)
1	*2462.00	115.81 PK			1.30 H	262	83.13	32.68
2	*2462.00	105.58 AV			1.30 H	262	72.90	32.68
3	2483.50	58.50 PK	74.00	-15.50	1.30 H	262	25.74	32.76
4	2483.50	47.91 AV	54.00	-6.09	1.30 H	262	15.15	32.76
5	4924.00	55.13 PK	74.00	-18.87	1.02 H	185	16.49	38.64
6	4924.00	41.86 AV	54.00	-12.14	1.02 H	185	3.22	38.64
7	7386.00	62.45 PK	74.00	-11.55	1.29 H	266	17.82	44.63
8	7386.00	48.41 AV	54.00	-5.59	1.29 H	266	3.78	44.63
9	#9848.00	69.21 PK	95.81	-26.60	1.32 H	146	20.72	48.49
10	#9848.00	54.92 AV	85.58	-30.66	1.32 H	146	6.43	48.49

ANTENNA POLARITY & TEST DISTANCE: VERTICAL AT 3 M								
NO.	FREQ. (MHz)	EMISSION LEVEL (dBuV/m)	LIMIT (dBuV/m)	MARGIN (dB)	ANTENNA HEIGHT (m)	TABLE ANGLE (Degree)	RAW VALUE (dBuV)	CORRECTION FACTOR (dB/m)
1	*2462.00	105.83 PK			1.41 V	191	73.15	32.68
2	*2462.00	95.72 AV			1.41 V	191	63.04	32.68
3	2483.50	57.26 PK	74.00	-16.74	1.41 V	191	24.50	32.76
4	2483.50	46.69 AV	54.00	-7.31	1.41 V	191	13.93	32.76
5	4924.00	54.81 PK	74.00	-19.19	1.01 V	26	16.17	38.64
6	4924.00	41.52 AV	54.00	-12.48	1.01 V	26	2.88	38.64
7	7386.00	63.16 PK	74.00	-10.84	1.25 V	281	18.53	44.63
8	7386.00	49.08 AV	54.00	-4.92	1.25 V	281	4.45	44.63
9	#9848.00	69.86 PK	85.83	-15.97	1.08 V	251	21.37	48.49
10	#9848.00	55.42 AV	75.72	-20.30	1.08 V	251	6.93	48.49

- REMARKS:**
1. Emission level (dBuV/m) = Raw Value (dBuV) + Correction Factor (dB/m).
 2. Correction Factor (dB/m) = Antenna Factor (dB/m) + Cable Factor (dB).
 3. The other emission levels were very low against the limit.
 4. Margin value = Emission level – Limit value.
 5. “ * “: Fundamental frequency.
 6. “#“: The radiated frequency is out the restricted band.



A D T

EUT TEST CONDITION		MEASUREMENT DETAIL	
CHANNEL	Channel 1	FREQUENCY RANGE	1 ~ 25GHz
INPUT POWER (SYSTEM)	120Vac, 60 Hz	DETECTOR FUNCTION	Peak (PK) Average (AV)
ENVIRONMENTAL CONDITIONS	24.0deg. C, 64.0%RH 1005hPa	TESTED BY	Brad Wu
TEST MODE	B		

ANTENNA POLARITY & TEST DISTANCE: HORIZONTAL AT 3 M								
NO.	FREQ. (MHz)	EMISSION LEVEL (dBuV/m)	LIMIT (dBuV/m)	MARGIN (dB)	ANTENNA HEIGHT (m)	TABLE ANGLE (Degree)	RAW VALUE (dBuV)	CORRECTION FACTOR (dB/m)
1	2390.00	62.30 PK	74.00	-11.70	1.22 H	75	29.86	32.44
2	2390.00	50.50 AV	54.00	-3.50	1.22 H	75	18.06	32.44
3	*2412.00	113.62 PK			1.22 H	75	81.10	32.52
4	*2412.00	103.31 AV			1.22 H	75	70.79	32.52
5	4824.00	50.31 PK	74.00	-23.69	1.02 H	312	12.01	38.30
6	4824.00	37.44 AV	54.00	-16.56	1.02 H	312	-0.86	38.30
7	#9648.00	68.41 PK	93.62	-25.21	1.33 H	152	20.16	48.25
8	#9648.00	53.60 AV	83.31	-29.71	1.33 H	152	5.35	48.25
ANTENNA POLARITY & TEST DISTANCE: VERTICAL AT 3 M								
NO.	FREQ. (MHz)	EMISSION LEVEL (dBuV/m)	LIMIT (dBuV/m)	MARGIN (dB)	ANTENNA HEIGHT (m)	TABLE ANGLE (Degree)	RAW VALUE (dBuV)	CORRECTION FACTOR (dB/m)
1	2390.00	57.22 PK	74.00	-16.78	1.14 V	158	24.78	32.44
2	2390.00	46.63 AV	54.00	-7.37	1.14 V	158	14.19	32.44
3	*2412.00	99.43 PK			1.14 V	158	66.91	32.52
4	*2412.00	89.08 AV			1.14 V	158	56.56	32.52
5	4824.00	50.02 PK	74.00	-23.98	1.04 V	223	11.72	38.30
6	4824.00	37.14 AV	54.00	-16.86	1.04 V	223	-1.16	38.30
7	#9648.00	71.18 PK	79.43	-8.25	1.53 V	221	22.93	48.25
8	#9648.00	55.97 AV	69.08	-13.11	1.53 V	221	7.72	48.25

- REMARKS:**
1. Emission level (dBuV/m) = Raw Value (dBuV) + Correction Factor (dB/m).
 2. Correction Factor (dB/m) = Antenna Factor (dB/m) + Cable Factor (dB).
 3. The other emission levels were very low against the limit.
 4. Margin value = Emission level – Limit value.
 5. “ * “: Fundamental frequency.
 6. “#”:The radiated frequency is out the restricted band.



EUT TEST CONDITION		MEASUREMENT DETAIL	
CHANNEL	Channel 6	FREQUENCY RANGE	1 ~ 25GHz
INPUT POWER (SYSTEM)	120Vac, 60 Hz	DETECTOR FUNCTION	Peak (PK) Average (AV)
ENVIRONMENTAL CONDITIONS	24.0deg. C, 64.0%RH 1005hPa	TESTED BY	Brad Wu
TEST MODE	B		

ANTENNA POLARITY & TEST DISTANCE: HORIZONTAL AT 3 M

NO.	FREQ. (MHz)	EMISSION LEVEL (dBuV/m)	LIMIT (dBuV/m)	MARGIN (dB)	ANTENNA HEIGHT (m)	TABLE ANGLE (Degree)	RAW VALUE (dBuV)	CORRECTION FACTOR (dB/m)
1	*2437.00	113.82 PK			1.23 H	76	81.22	32.60
2	*2437.00	103.62 AV			1.23 H	76	71.02	32.60
3	4874.00	50.46 PK	74.00	-23.54	1.03 H	211	11.96	38.50
4	4874.00	37.61 AV	54.00	-16.39	1.03 H	211	-0.89	38.50
5	7311.00	60.57 PK	74.00	-13.43	1.09 H	207	16.09	44.48
6	7311.00	47.77 AV	54.00	-6.23	1.09 H	207	3.29	44.48
7	#9748.00	68.45 PK	93.82	-25.37	1.09 H	271	20.05	48.40
8	#9748.00	54.02 AV	83.62	-29.60	1.09 H	271	5.62	48.40

ANTENNA POLARITY & TEST DISTANCE: VERTICAL AT 3 M

NO.	FREQ. (MHz)	EMISSION LEVEL (dBuV/m)	LIMIT (dBuV/m)	MARGIN (dB)	ANTENNA HEIGHT (m)	TABLE ANGLE (Degree)	RAW VALUE (dBuV)	CORRECTION FACTOR (dB/m)
1	*2437.00	99.69 PK			1.15 V	159	67.09	32.60
2	*2437.00	89.41 AV			1.15 V	159	56.81	32.60
3	4874.00	50.13 PK	74.00	-23.87	1.05 V	102	11.63	38.50
4	4874.00	37.29 AV	54.00	-16.71	1.05 V	102	-1.21	38.50
5	7311.00	61.04 PK	74.00	-12.96	1.03 V	309	16.56	44.48
6	7311.00	48.02 AV	54.00	-5.98	1.03 V	309	3.54	44.48
7	#9748.00	68.84 PK	79.69	-10.85	1.13 V	243	20.44	48.40
8	#9748.00	54.36 AV	69.41	-15.05	1.13 V	243	5.96	48.40

- REMARKS:**
1. Emission level (dBuV/m) = Raw Value (dBuV) + Correction Factor (dB/m).
 2. Correction Factor (dB/m) = Antenna Factor (dB/m) + Cable Factor (dB).
 3. The other emission levels were very low against the limit.
 4. Margin value = Emission level – Limit value.
 5. “ * “: Fundamental frequency.
 6. “#”:The radiated frequency is out the restricted band.



A D T

EUT TEST CONDITION		MEASUREMENT DETAIL	
CHANNEL	Channel 11	FREQUENCY RANGE	1 ~ 25GHz
INPUT POWER (SYSTEM)	120Vac, 60 Hz	DETECTOR FUNCTION	Peak (PK) Average (AV)
ENVIRONMENTAL CONDITIONS	24.0deg. C, 64.0%RH 1005hPa	TESTED BY	Brad Wu
TEST MODE	B		

ANTENNA POLARITY & TEST DISTANCE: HORIZONTAL AT 3 M								
NO.	FREQ. (MHz)	EMISSION LEVEL (dBuV/m)	LIMIT (dBuV/m)	MARGIN (dB)	ANTENNA HEIGHT (m)	TABLE ANGLE (Degree)	RAW VALUE (dBuV)	CORRECTION FACTOR (dB/m)
1	*2462.00	113.92 PK			1.21 H	77	81.24	32.68
2	*2462.00	103.63 AV			1.21 H	77	70.95	32.68
3	2483.50	57.62 PK	74.00	-16.38	1.21 H	77	24.86	32.76
4	2483.50	47.29 AV	54.00	-6.71	1.21 H	77	14.53	32.76
5	4924.00	50.63 PK	74.00	-23.37	1.14 H	25	11.99	38.64
6	4924.00	37.82 AV	54.00	-16.18	1.14 H	25	-0.82	38.64
7	7386.00	60.86 PK	74.00	-13.14	1.10 H	209	16.23	44.63
8	7386.00	47.95 AV	54.00	-6.05	1.10 H	209	3.32	44.63
9	#9848.00	68.66 PK	93.92	-25.26	1.08 H	276	20.17	48.49
10	#9848.00	54.31 AV	83.63	-29.32	1.08 H	276	5.82	48.49

ANTENNA POLARITY & TEST DISTANCE: VERTICAL AT 3 M								
NO.	FREQ. (MHz)	EMISSION LEVEL (dBuV/m)	LIMIT (dBuV/m)	MARGIN (dB)	ANTENNA HEIGHT (m)	TABLE ANGLE (Degree)	RAW VALUE (dBuV)	CORRECTION FACTOR (dB/m)
1	*2462.00	99.81 PK			1.16 V	161	67.13	32.68
2	*2462.00	89.57 AV			1.16 V	161	56.89	32.68
3	2483.50	57.03 PK	74.00	-16.97	1.16 V	161	24.27	32.76
4	2483.50	46.71 AV	54.00	-7.29	1.16 V	161	13.95	32.76
5	4924.00	50.12 PK	74.00	-23.88	1.04 V	311	11.48	38.64
6	4924.00	37.34 AV	54.00	-16.66	1.04 V	311	-1.30	38.64
7	7386.00	61.14 PK	74.00	-12.86	1.05 V	331	16.51	44.63
8	7386.00	48.25 AV	54.00	-5.75	1.05 V	331	3.62	44.63
9	#9848.00	68.92 PK	79.81	-10.89	1.09 V	251	20.43	48.49
10	#9848.00	54.64 AV	69.57	-14.93	1.09 V	251	6.15	48.49

- REMARKS:**
1. Emission level (dBuV/m) = Raw Value (dBuV) + Correction Factor (dB/m).
 2. Correction Factor (dB/m) = Antenna Factor (dB/m) + Cable Factor (dB).
 3. The other emission levels were very low against the limit.
 4. Margin value = Emission level – Limit value.
 5. “ * “: Fundamental frequency.
 6. “#“: The radiated frequency is out the restricted band.

BELOW 1GHz WORST-CASE DATA : 802.11g OFDM MODULATION

EUT TEST CONDITION		MEASUREMENT DETAIL	
CHANNEL	Channel 6	FREQUENCY RANGE	Below 1000MHz
INPUT POWER (SYSTEM)	120Vac, 60 Hz	DETECTOR FUNCTION	Quasi-Peak
ENVIRONMENTAL CONDITIONS	24.0deg. C, 64.0%RH 1005hPa	TESTED BY	Brad Wu
TEST MODE	A		

ANTENNA POLARITY & TEST DISTANCE: HORIZONTAL AT 3 M								
NO.	FREQ. (MHz)	EMISSION LEVEL (dBuV/m)	LIMIT (dBuV/m)	MARGIN (dB)	ANTENNA HEIGHT (m)	TABLE ANGLE (Degree)	RAW VALUE (dBuV)	CORRECTION FACTOR (dB/m)
1	101.84	39.57 QP	43.50	-3.93	2.00 H	193	27.99	11.58
2	142.67	38.00 QP	43.50	-5.50	2.00 H	229	24.79	13.22
3	249.99	44.82 QP	46.00	-1.18	1.11 H	204	30.99	13.83
4	274.88	40.46 QP	46.00	-5.54	1.00 H	181	26.70	13.76
5	500.42	32.60 QP	46.00	-13.40	1.50 H	166	12.16	20.44
6	751.23	33.43 QP	46.00	-12.57	1.00 H	160	7.92	25.51

ANTENNA POLARITY & TEST DISTANCE: VERTICAL AT 3 M								
NO.	FREQ. (MHz)	EMISSION LEVEL (dBuV/m)	LIMIT (dBuV/m)	MARGIN (dB)	ANTENNA HEIGHT (m)	TABLE ANGLE (Degree)	RAW VALUE (dBuV)	CORRECTION FACTOR (dB/m)
1	69.01	38.83 QP	40.00	-1.17	1.00 V	274	25.60	13.23
2	107.67	39.55 QP	43.50	-3.95	1.00 V	97	28.06	11.50
3	249.60	43.95 QP	46.00	-2.05	1.00 V	313	30.14	13.80
4	274.88	41.49 QP	46.00	-4.51	1.00 V	157	27.73	13.76
5	368.21	33.29 QP	46.00	-12.71	1.25 V	169	16.58	16.71
6	500.42	32.41 QP	46.00	-13.59	1.00 V	193	11.97	20.44

- REMARKS:**
1. Emission level (dBuV/m) = Raw Value (dBuV) + Correction Factor (dB/m).
 2. Correction Factor (dB/m) = Antenna Factor (dB/m) + Cable Factor (dB).
 3. The other emission levels were very low against the limit.
 4. Margin value = Emission level – Limit value.



A D T

EUT TEST CONDITION		MEASUREMENT DETAIL	
CHANNEL	Channel 6	FREQUENCY RANGE	Below 1000MHz
INPUT POWER (SYSTEM)	120Vac, 60 Hz	DETECTOR FUNCTION	Quasi-Peak
ENVIRONMENTAL CONDITIONS	24.0deg. C, 64.0%RH 1005hPa	TESTED BY	Brad Wu
TEST MODE	B		

ANTENNA POLARITY & TEST DISTANCE: HORIZONTAL AT 3 M								
NO.	FREQ. (MHz)	EMISSION LEVEL (dBuV/m)	LIMIT (dBuV/m)	MARGIN (dB)	ANTENNA HEIGHT (m)	TABLE ANGLE (Degree)	RAW VALUE (dBuV)	CORRECTION FACTOR (dB/m)
1	101.84	40.40 QP	43.50	-3.10	2.00 H	211	28.82	11.58
2	249.60	44.69 QP	46.00	-1.31	1.00 H	208	30.89	13.80
3	274.88	37.93 QP	46.00	-8.07	1.50 H	229	24.17	13.76
4	459.59	31.19 QP	46.00	-14.81	2.00 H	166	11.67	19.52
5	500.42	31.89 QP	46.00	-14.11	1.50 H	175	11.45	20.44
6	751.23	33.17 QP	46.00	-12.83	1.00 H	160	7.66	25.51

ANTENNA POLARITY & TEST DISTANCE: VERTICAL AT 3 M								
NO.	FREQ. (MHz)	EMISSION LEVEL (dBuV/m)	LIMIT (dBuV/m)	MARGIN (dB)	ANTENNA HEIGHT (m)	TABLE ANGLE (Degree)	RAW VALUE (dBuV)	CORRECTION FACTOR (dB/m)
1	68.79	38.86 QP	40.00	-1.14	1.00 V	232	25.64	13.22
2	111.56	39.52 QP	43.50	-3.98	1.00 V	244	28.08	11.44
3	183.50	37.59 QP	43.50	-5.91	1.00 V	175	26.21	11.38
4	249.60	44.13 QP	46.00	-1.87	1.00 V	316	30.32	13.80
5	368.21	33.04 QP	46.00	-12.96	1.00 V	169	16.33	16.71
6	875.67	32.25 QP	46.00	-13.75	1.00 V	100	4.82	27.43

- REMARKS:**
1. Emission level (dBuV/m) = Raw Value (dBuV) + Correction Factor (dB/m).
 2. Correction Factor (dB/m) = Antenna Factor (dB/m) + Cable Factor (dB).
 3. The other emission levels were very low against the limit.
 4. Margin value = Emission level – Limit value.

4.2 CONDUCTED EMISSION MEASUREMENT

4.2.1 LIMITS OF CONDUCTED EMISSION MEASUREMENT

FREQUENCY OF EMISSION (MHz)	CONDUCTED LIMIT (dB μ V)	
	Quasi-peak	Average
0.15 ~ 0.5	66 to 56	56 to 46
0.5 ~ 5	56	46
5 ~ 30	60	50

- NOTE:**
1. The lower limit shall apply at the transition frequencies.
 2. The limit decreases in line with the logarithm of the frequency in the range of 0.15 to 0.50 MHz.
 3. All emanations from a class A/B digital device or system, including any network of conductors and apparatus connected thereto, shall not exceed the level of field strengths specified above.

4.2.2 TEST INSTRUMENTS

DESCRIPTION & MANUFACTURER	MODEL NO.	SERIAL NO.	DATE OF CALIBRATION	DUE DATE OF CALIBRATION
Test Receiver ROHDE & SCHWARZ	ESCS30	100288	Sep. 22, 2008	Sep. 21, 2009
RF signal cable Woken	5D-FB	Cable-HYCO2-01	Dec. 31, 2008	Dec. 30, 2009
LISN ROHDE & SCHWARZ	ESH2-Z5	100100	Dec. 29, 2008	Dec. 28, 2009
LISN ROHDE & SCHWARZ	ESH3-Z5	100311	Jul. 30, 2008	Jul. 29, 2009
Software ADT	ADT_Cond_ V7.3.7	NA	NA	NA

- NOTE:**
1. The calibration interval of the above test instruments is 12 months and the calibrations are traceable to NML/ROC and NIST/USA.
 2. The test was performed in HwaYa Shielded Room 2.
 3. The VCCI Site Registration No. is C-2047.

4.2.3 TEST PROCEDURES

- a. The EUT was placed 0.4 meters from the conducting wall of the shielded room with EUT being connected to the power mains through a line impedance stabilization network (LISN). Other support units were connected to the power mains through another LISN. The two LISNs provide 50 ohm/ 50uH of coupling impedance for the measuring instrument.
- b. Both lines of the power mains connected to the EUT were checked for maximum conducted interference.
- c. The frequency range from 150kHz to 30MHz was searched. Emission levels under (Limit - 20dB) was not recorded.

NOTE: All modes of operation were investigated and the worst-case emissions are reported.

4.2.4 DEVIATION FROM TEST STANDARD

No deviation.

4.2.5 TEST SETUP

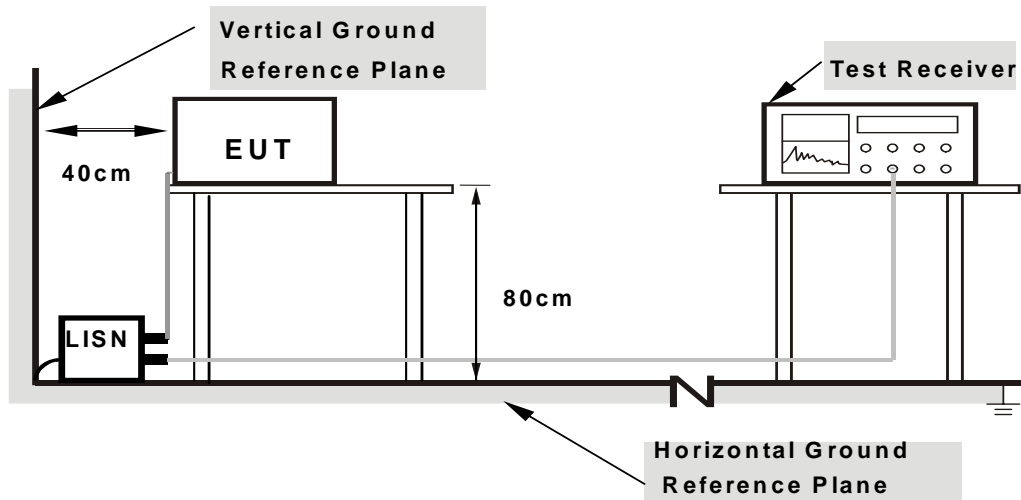

Note: 1.Support units were connected to second LISN.

2.Both of LISNs (AMN) are 80 cm from EUT and at least 80 from other units and other metal planes

For the actual test configuration, please refer to the attached file (Test Setup Photo).

4.2.6 EUT OPERATING CONDITIONS

Same as 4.1.6.

4.2.7 TEST RESULTS

CONDUCTED WORST-CASE DATA : 802.11g OFDM MODULATION

EUT TEST CONDITION		MEASUREMENT DETAIL	
CHANNEL	Channel 6	PHASE	Line 1
MODULATION TYPE	BPSK	6dB BANDWIDTH	9 kHz
TRANSFER RATE	6Mbps	ENVIRONMENTAL CONDITIONS	25deg. C, 65%RH, 1008hPa
INPUT POWER	120Vac, 60 Hz	TEST MODE	A
TESTED BY	Peter Lin		

No	Freq. [MHz]	Corr. Factor (dB)	Reading Value [dB (uV)]		Emission Level [dB (uV)]		Limit [dB (uV)]		Margin (dB)	
			Q.P.	AV.	Q.P.	AV.	Q.P.	AV.	Q.P.	AV.
1	0.158	0.13	53.73	-	53.86	-	65.58	55.58	-11.72	-
2	0.189	0.13	50.95	-	51.08	-	64.08	54.08	-13.00	-
3	0.224	0.13	48.87	-	49.00	-	62.66	52.66	-13.66	-
4	0.252	0.13	47.69	-	47.82	-	61.71	51.71	-13.88	-
5	0.283	0.13	44.98	-	45.11	-	60.73	50.73	-15.62	-
6	0.435	0.14	41.31	-	41.45	-	57.15	47.15	-15.70	-
7	0.677	0.15	41.87	-	42.02	-	56.00	46.00	-13.98	-
8	0.810	0.16	41.88	-	42.04	-	56.00	46.00	-13.96	-
9	0.994	0.17	40.82	-	40.99	-	56.00	46.00	-15.01	-
10	1.738	0.18	42.16	-	42.34	-	56.00	46.00	-13.66	-
11	2.613	0.22	41.05	-	41.27	-	56.00	46.00	-14.73	-
12	21.910	0.66	45.67	-	46.33	-	60.00	50.00	-13.67	-

- REMARKS:**
1. Q.P. and AV. are abbreviations of quasi-peak and average individually.
 2. "-": The Quasi-peak reading value also meets average limit and measurement with the average detector is unnecessary.
 3. The emission levels of other frequencies were very low against the limit.
 4. Margin value = Emission level - Limit value
 5. Correction factor = Insertion loss + Cable loss
 6. Emission Level = Correction Factor + Reading Value.

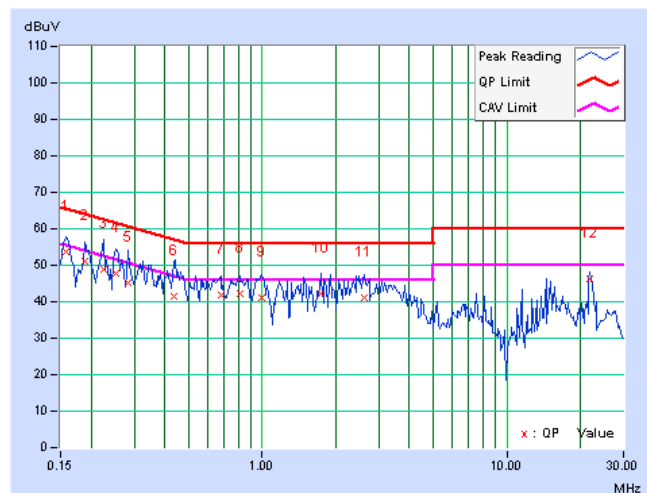

EUT TEST CONDITION		MEASUREMENT DETAIL	
CHANNEL	Channel 6	PHASE	Line 2
MODULATION TYPE	BPSK	6dB BANDWIDTH	9 kHz
TRANSFER RATE	6Mbps	ENVIRONMENTAL CONDITIONS	25deg. C, 65%RH, 1008hPa
INPUT POWER	120Vac, 60 Hz	TEST MODE	A
TESTED BY	Peter Lin		

No	Freq. [MHz]	Corr. Factor (dB)	Reading Value [dB (uV)]		Emission Level [dB (uV)]		Limit [dB (uV)]		Margin (dB)	
			Q.P.	AV.	Q.P.	AV.	Q.P.	AV.	Q.P.	AV.
1	0.158	0.13	51.92	-	52.05	-	65.58	55.58	-13.53	-
2	0.189	0.13	50.67	-	50.80	-	64.08	54.08	-13.28	-
3	0.224	0.13	47.99	-	48.12	-	62.66	52.66	-14.54	-
4	0.259	0.14	46.45	-	46.59	-	61.45	51.45	-14.87	-
5	0.314	0.14	44.31	-	44.45	-	59.86	49.86	-15.41	-
6	0.408	0.15	40.93	-	41.08	-	57.69	47.69	-16.61	-
7	0.509	0.15	38.59	-	38.74	-	56.00	46.00	-17.26	-
8	0.564	0.16	37.60	-	37.76	-	56.00	46.00	-18.24	-
9	0.779	0.16	37.07	-	37.23	-	56.00	46.00	-18.77	-
10	1.488	0.18	41.73	-	41.91	-	56.00	46.00	-14.09	-
11	2.410	0.22	40.94	-	41.16	-	56.00	46.00	-14.84	-
12	21.910	0.81	45.09	-	45.90	-	60.00	50.00	-14.10	-

- REMARKS:**
1. Q.P. and AV. are abbreviations of quasi-peak and average individually.
 2. "-": The Quasi-peak reading value also meets average limit and measurement with the average detector is unnecessary.
 3. The emission levels of other frequencies were very low against the limit.
 4. Margin value = Emission level - Limit value
 5. Correction factor = Insertion loss + Cable loss
 6. Emission Level = Correction Factor + Reading Value.

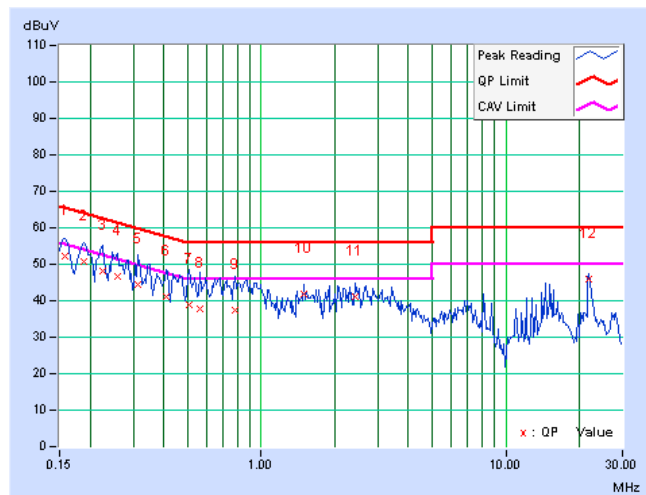

EUT TEST CONDITION		MEASUREMENT DETAIL	
CHANNEL	Channel 6	PHASE	Line 1
MODULATION TYPE	BPSK	6dB BANDWIDTH	9 kHz
TRANSFER RATE	6Mbps	ENVIRONMENTAL CONDITIONS	25deg. C, 65%RH, 1008hPa
INPUT POWER	120Vac, 60 Hz	TEST MODE	B
TESTED BY	Peter Lin		

No	Freq. [MHz]	Corr. Factor (dB)	Reading Value [dB (uV)]		Emission Level [dB (uV)]		Limit [dB (uV)]		Margin (dB)	
			Q.P.	AV.	Q.P.	AV.	Q.P.	AV.	Q.P.	AV.
1	0.162	0.13	52.42	-	52.55	-	65.38	55.38	-12.83	-
2	0.193	0.13	52.10	-	52.23	-	63.91	53.91	-11.68	-
3	0.220	0.13	48.92	-	49.05	-	62.81	52.81	-13.76	-
4	0.252	0.13	47.71	-	47.84	-	61.71	51.71	-13.86	-
5	0.353	0.14	44.95	-	45.09	-	58.89	48.89	-13.80	-
6	0.451	0.14	42.82	-	42.96	-	56.86	46.86	-13.90	-
7	0.509	0.15	38.77	-	38.92	-	56.00	46.00	-17.08	-
8	0.670	0.15	42.62	-	42.77	-	56.00	46.00	-13.23	-
9	0.994	0.17	40.98	-	41.15	-	56.00	46.00	-14.85	-
10	1.156	0.17	41.72	-	41.89	-	56.00	46.00	-14.11	-
11	2.699	0.22	43.89	-	44.11	-	56.00	46.00	-11.89	-
12	21.668	0.66	43.66	-	44.32	-	60.00	50.00	-15.68	-

- REMARKS:**
1. Q.P. and AV. are abbreviations of quasi-peak and average individually.
 2. "-": The Quasi-peak reading value also meets average limit and measurement with the average detector is unnecessary.
 3. The emission levels of other frequencies were very low against the limit.
 4. Margin value = Emission level - Limit value
 5. Correction factor = Insertion loss + Cable loss
 6. Emission Level = Correction Factor + Reading Value.

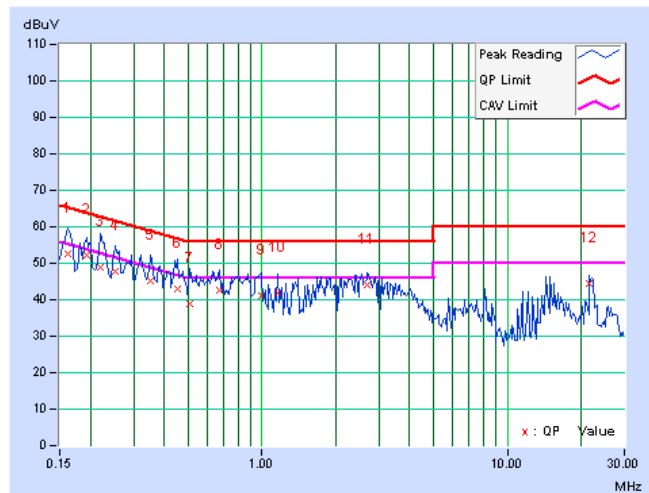



A D T

EUT TEST CONDITION		MEASUREMENT DETAIL	
CHANNEL	Channel 6	PHASE	Line 2
MODULATION TYPE	BPSK	6dB BANDWIDTH	9 kHz
TRANSFER RATE	6Mbps	ENVIRONMENTAL CONDITIONS	25deg. C, 65%RH, 1008hPa
INPUT POWER	120Vac, 60 Hz	TEST MODE	B
TESTED BY	Peter Lin		

No	Freq. [MHz]	Corr. Factor (dB)	Reading Value [dB (uV)]		Emission Level [dB (uV)]		Limit [dB (uV)]		Margin (dB)	
			Q.P.	AV.	Q.P.	AV.	Q.P.	AV.	Q.P.	AV.
1	0.158	0.13	52.12	-	52.25	-	65.58	55.58	-13.33	-
2	0.197	0.13	51.53	-	51.66	-	63.74	53.74	-12.08	-
3	0.224	0.13	50.17	-	50.30	-	62.66	52.66	-12.36	-
4	0.259	0.14	48.07	-	48.21	-	61.45	51.45	-13.25	-
5	0.291	0.14	47.02	-	47.16	-	60.51	50.51	-13.35	-
6	0.349	0.14	45.29	-	45.43	-	58.98	48.98	-13.55	-
7	0.439	0.15	41.71	-	41.86	-	57.08	47.08	-15.22	-
8	0.689	0.16	38.19	-	38.35	-	56.00	46.00	-17.65	-
9	0.877	0.17	42.12	-	42.29	-	56.00	46.00	-13.71	-
10	1.074	0.17	40.71	-	40.88	-	56.00	46.00	-15.12	-
11	1.480	0.18	40.44	-	40.62	-	56.00	46.00	-15.38	-
12	2.484	0.22	41.66	-	41.88	-	56.00	46.00	-14.12	-
13	21.910	0.81	45.09	-	45.90	-	60.00	50.00	-14.10	-

- REMARKS:**
1. Q.P. and AV. are abbreviations of quasi-peak and average individually.
 2. "-": The Quasi-peak reading value also meets average limit and measurement with the average detector is unnecessary.
 3. The emission levels of other frequencies were very low against the limit.
 4. Margin value = Emission level - Limit value
 5. Correction factor = Insertion loss + Cable loss
 6. Emission Level = Correction Factor + Reading Value.

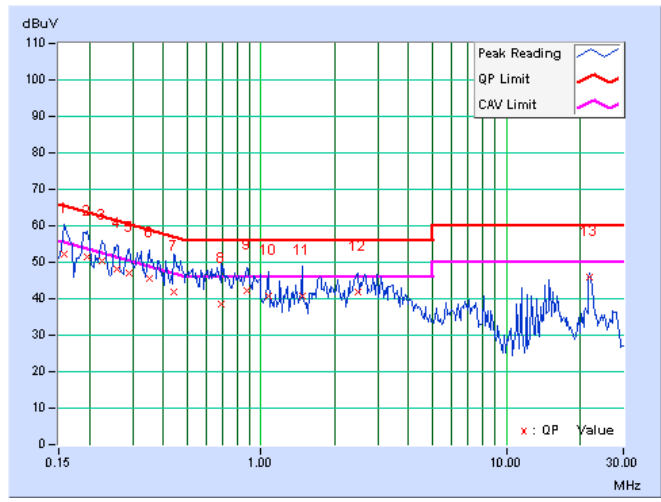

4.3 6dB BANDWIDTH MEASUREMENT

4.3.1 LIMITS OF 6dB BANDWIDTH MEASUREMENT

The minimum of 6dB Bandwidth Measurement is 0.5 MHz.

4.3.2 TEST INSTRUMENTS

DESCRIPTION & MANUFACTURER	MODEL NO.	SERIAL NO.	DATE OF CALIBRATION	CALIBRATED UNTIL
R&S SPECTRUM ANALYZER	FSP40	100040	Jul. 04, 2008	Jul. 03, 2009

NOTE: The calibration interval of the above test instruments is 12 months and the calibrations are traceable to NML/ROC and NIST/USA.

4.3.3 TEST PROCEDURE

The transmitter output was connected to the spectrum analyzer through an attenuator. The bandwidth of the fundamental frequency was measured by spectrum analyzer with 100 kHz RBW and 300kHz VBW. The 6dB bandwidth is defined as the total spectrum the power of which is higher than peak power minus 6dB.

4.3.4 DEVIATION FROM TEST STANDARD

No deviation.

4.3.5 TEST SETUP

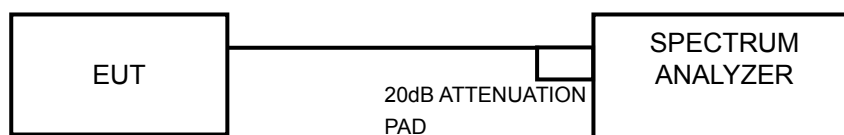

4.3.6 EUT OPERATING CONDITIONS

The software provided by client to enable the EUT under transmission condition continuously at lowest, middle and highest channel frequencies individually.

4.3.7 TEST RESULTS

802.11b DSSS MODULATION

MODULATION TYPE	DBPSK	TRANSFER RATE	1Mbps
INPUT POWER	120Vac, 60 Hz	ENVIRONMENTAL CONDITIONS	25deg. C, 66%RH, 1004hPa
TESTED BY	Antony Lee		

CHANNEL	CHANNEL FREQUENCY (MHz)	6dB BANDWIDTH (MHz)	MINIMUM LIMIT (MHz)	PASS/FAIL
1	2412	11.15	0.5	PASS
6	2437	11.14	0.5	PASS
11	2462	10.63	0.5	PASS

CH 1

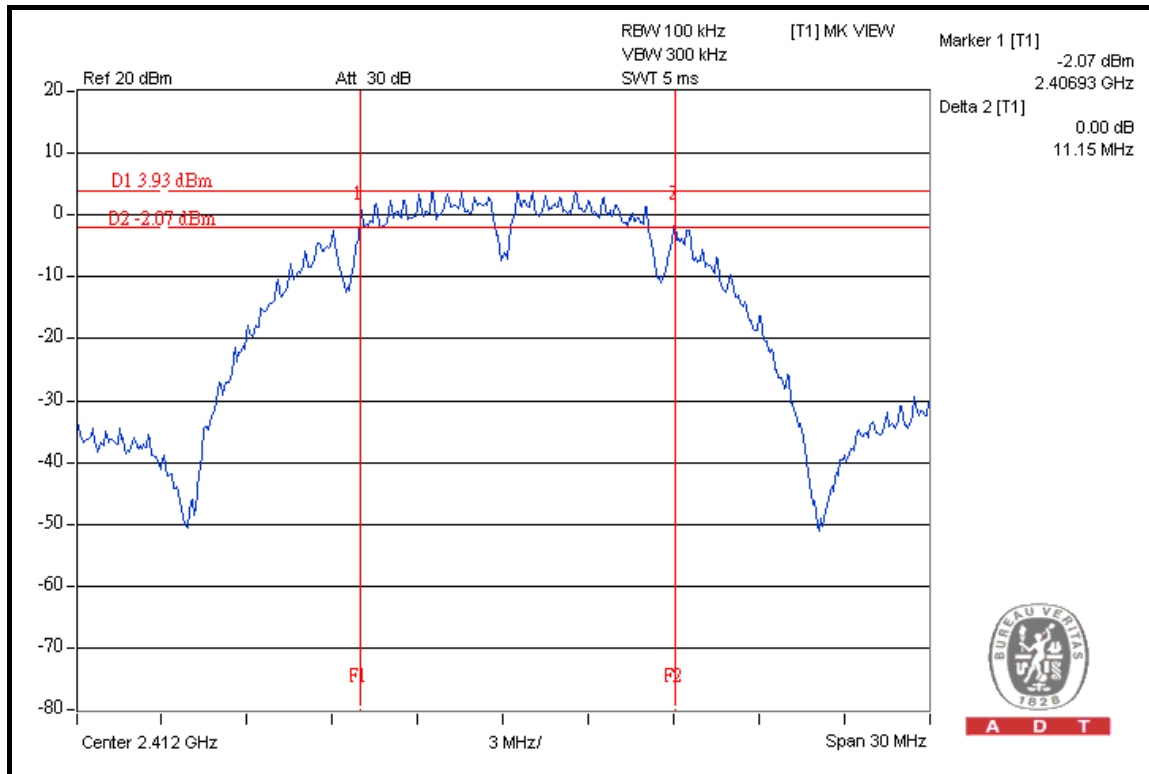



A D T

CH 6

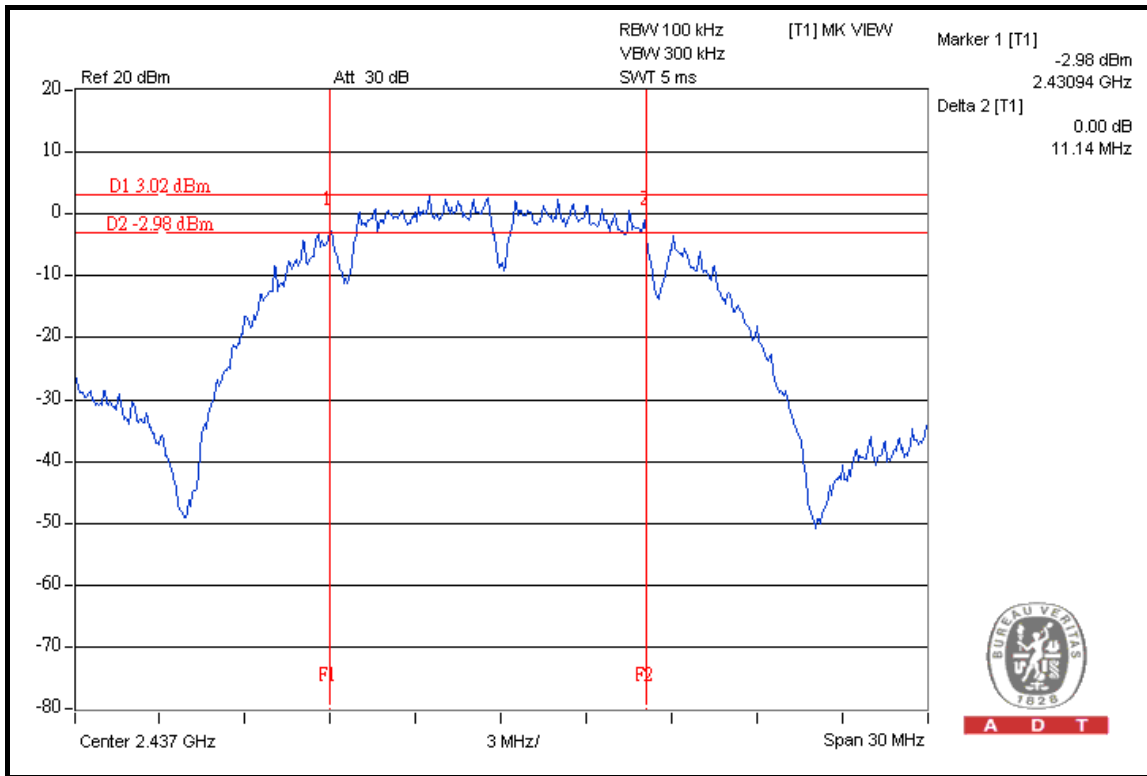

CH 11

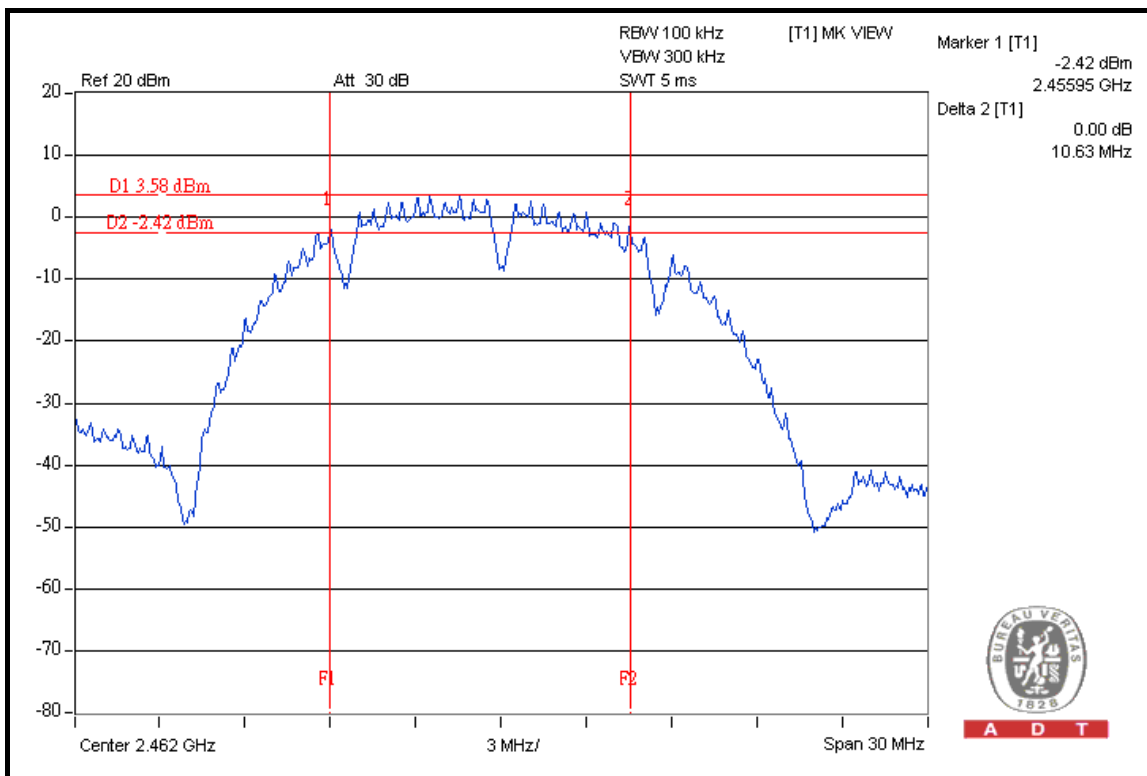



A D T

802.11g OFDM MODULATION

MODULATION TYPE	BPSK	TRANSFER RATE	6Mbps
INPUT POWER	120Vac, 60 Hz	ENVIRONMENTAL CONDITIONS	25deg. C, 66%RH, 1004hPa
TESTED BY	Antony Lee		

CHANNEL	CHANNEL FREQUENCY (MHz)	6dB BANDWIDTH (MHz)	MINIMUM LIMIT (MHz)	PASS/FAIL
1	2412	16.32	0.5	PASS
6	2437	16.42	0.5	PASS
11	2462	15.78	0.5	PASS

CH 1

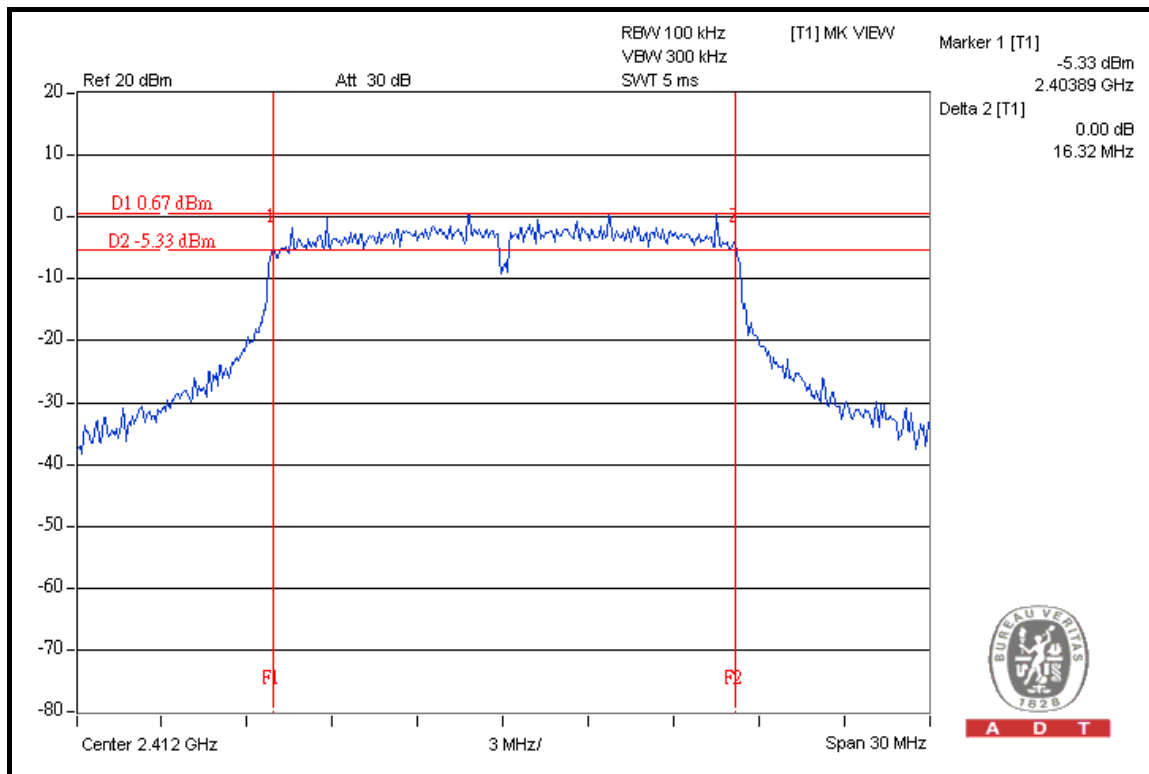



A D T

CH 6

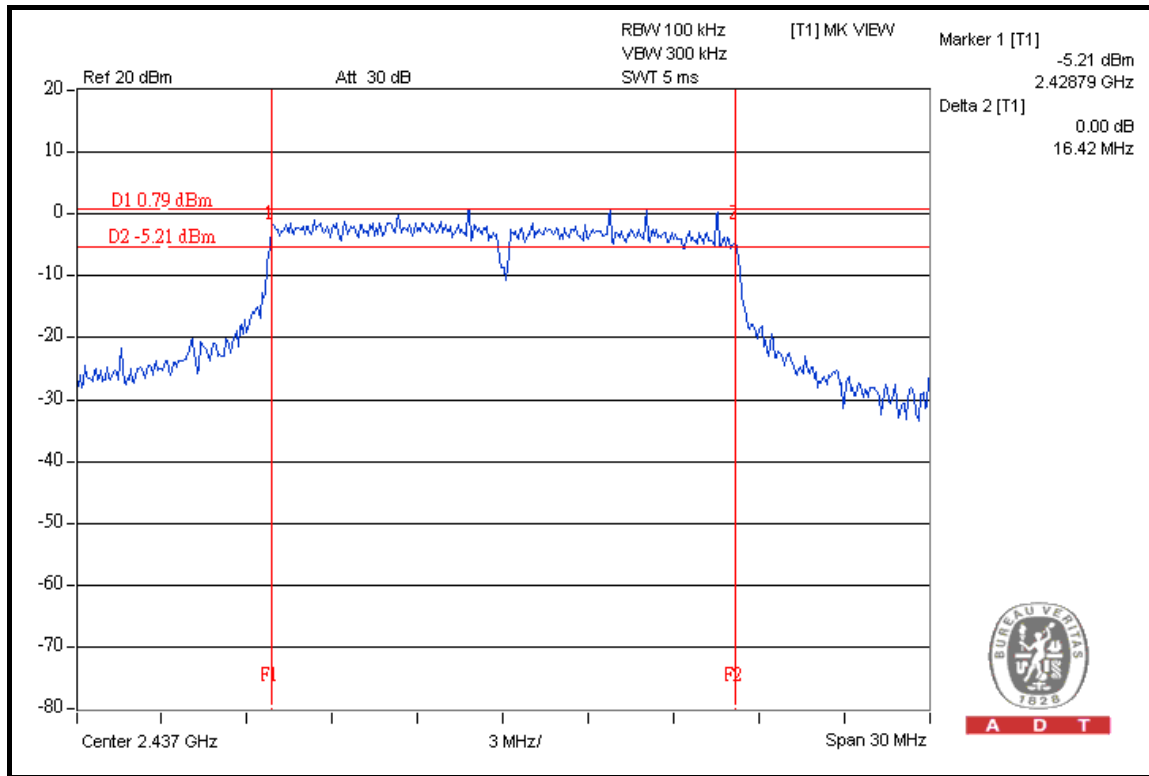

CH 11

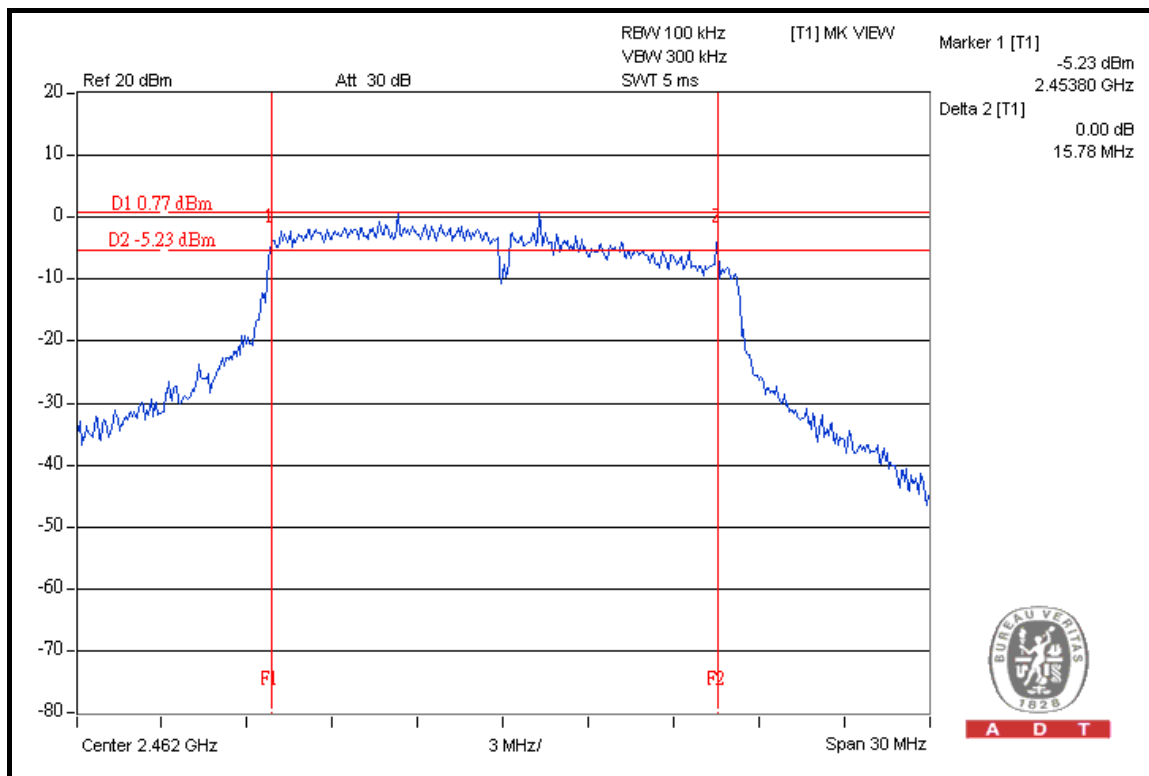

4.4 MAXIMUM PEAK OUTPUT POWER

4.4.1 LIMITS OF MAXIMUM PEAK OUTPUT POWER MEASUREMENT

The Maximum Peak Output Power Measurement is 30dBm.

4.4.2 TEST INSTRUMENTS

DESCRIPTION & MANUFACTURER	MODEL NO.	SERIAL NO.	DATE OF CALIBRATION	CALIBRATED UNTIL
High Speed Peak Power Meter	ML2495A	0824012	Aug. 04, 2008	Aug. 03, 2009
Power Sensor	MA2411B	0738138	Aug. 04, 2008	Aug. 03, 2009

NOTE:

1. The calibration interval of the above test instruments is 12 months and the calibrations are traceable to NML/ROC and NIST/USA.
2. Measurement Bandwidth of ML2495A is 65MHz greater than 6dB bandwidth of emission.

4.4.3 TEST PROCEDURES

A power sensor was used on the output port of the EUT. A power meter was used to read the response of the power sensor. Record the power level.

4.4.4 DEVIATION FROM TEST STANDARD

No deviation.

4.4.5 TEST SETUP

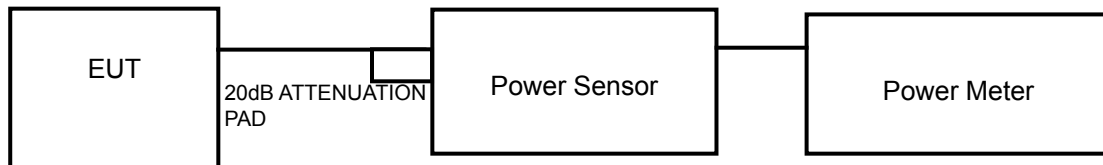

4.4.6 EUT OPERATING CONDITIONS

Same as 4.3.6.

4.4.7 TEST RESULTS

802.11b DSSS MODULATION

MODULATION TYPE	DBPSK	TRANSFER RATE	1Mbps
INPUT POWER	120Vac, 60 Hz	ENVIRONMENTAL CONDITIONS	25deg. C, 66%RH, 1004hPa
TESTED BY	Antony Lee		

CHANNEL	CHANNEL FREQUENCY (MHz)	PEAK POWER OUTPUT (mW)	PEAK POWER OUTPUT (dBm)	PEAK POWER LIMIT (dBm)	PASS/FAIL
1	2412	71.945	18.57	29	PASS
6	2437	57.412	17.59	29	PASS
11	2462	63.533	18.03	29	PASS

NOTE: According to 15.247 (b) (4), the maximum antenna gain 7dBi is higher than 6dBi, so the limit of peak power shall be reduced by 1dBm.

802.11g OFDM MODULATION

MODULATION TYPE	BPSK	TRANSFER RATE	6Mbps
INPUT POWER	120Vac, 60 Hz	ENVIRONMENTAL CONDITIONS	25deg. C, 65%RH, 1013hPa
TESTED BY	Antony Lee		

CHANNEL	CHANNEL FREQUENCY (MHz)	PEAK POWER OUTPUT (mW)	PEAK POWER OUTPUT (dBm)	PEAK POWER LIMIT (dBm)	PASS/FAIL
1	2412	200.909	23.03	29	PASS
6	2437	203.704	23.09	29	PASS
11	2462	201.837	23.05	29	PASS

NOTE: According to 15.247 (b) (4), the maximum antenna gain 7dBi is higher than 6dBi, so the limit of peak power shall be reduced by 1dBm.



4.5 POWER SPECTRAL DENSITY MEASUREMENT

4.5.1 LIMITS OF POWER SPECTRAL DENSITY MEASUREMENT

The Maximum of Power Spectral Density Measurement is 8dBm.

4.5.2 TEST INSTRUMENTS

DESCRIPTION & MANUFACTURER	MODEL NO.	SERIAL NO.	DATE OF CALIBRATION	CALIBRATED UNTIL
R&S SPECTRUM ANALYZER	FSP40	100040	Jul. 04, 2008	Jul. 03, 2009

NOTE: The calibration interval of the above test instruments is 12 months and the calibrations are traceable to NML/ROC and NIST/USA.

4.5.3 TEST PROCEDURE

The transmitter output was connected to the spectrum analyzer through an attenuator, the bandwidth of the fundamental frequency was measured with the spectrum analyzer using 3kHz RBW and 30kHz VBW, set sweep time = span/3kHz. The power spectral density was measured and recorded.

The sweep time is allowed to be longer than span/3kHz for a full response of the mixer in the spectrum analyzer.

4.5.4 DEVIATION FROM TEST STANDARD

No deviation.

4.5.5 TEST SETUP

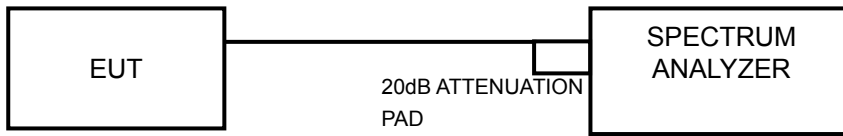

4.5.6 EUT OPERATING CONDITIONS

Same as 4.3.6.

4.5.7 TEST RESULTS

802.11b DSSS MODULATION

MODULATION TYPE	DBPSK	TRANSFER RATE	1Mbps
INPUT POWER	120Vac, 60 Hz	ENVIRONMENTAL CONDITIONS	25deg. C, 66%RH, 1004hPa
TESTED BY	Antony Lee		

CHANNEL	CHANNEL FREQUENCY (MHz)	RF POWER LEVEL IN 3 kHz BW (dBm)	MAXIMUM LIMIT (dBm)	PASS/FAIL
1	2412	-9.79	8	PASS
6	2437	-11.00	8	PASS
11	2462	-10.12	8	PASS

CH 1

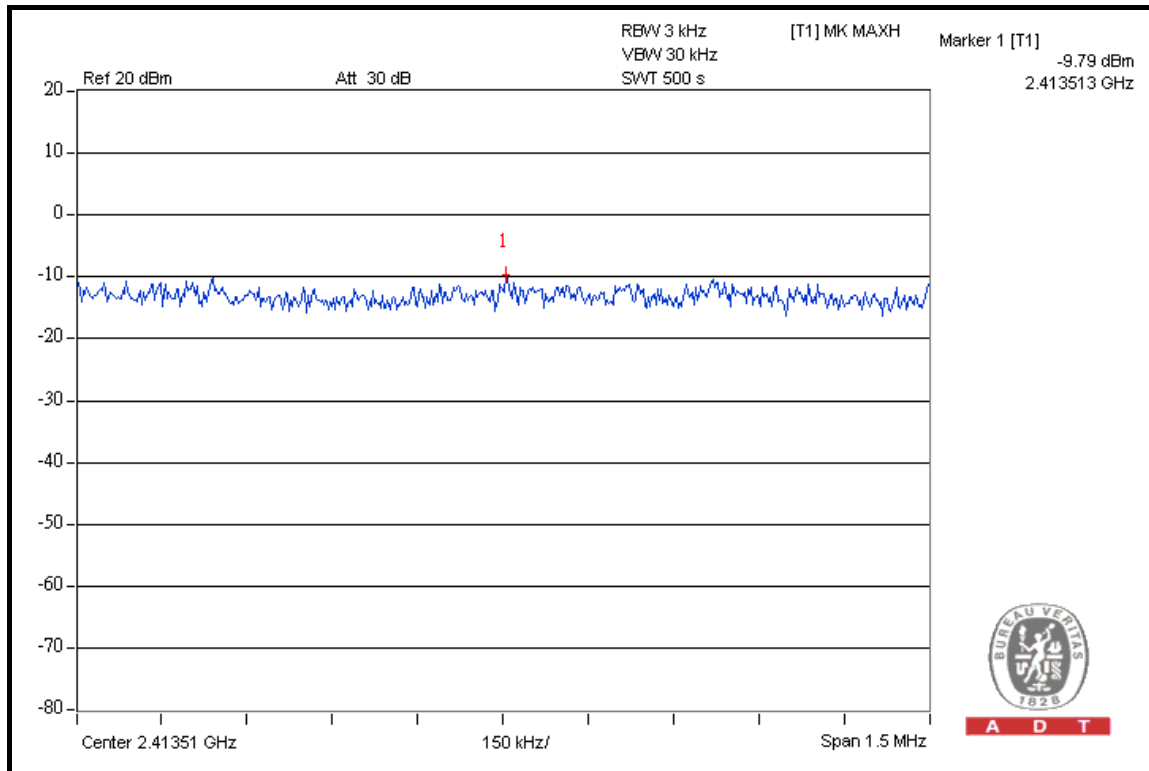



A D T

CH 6

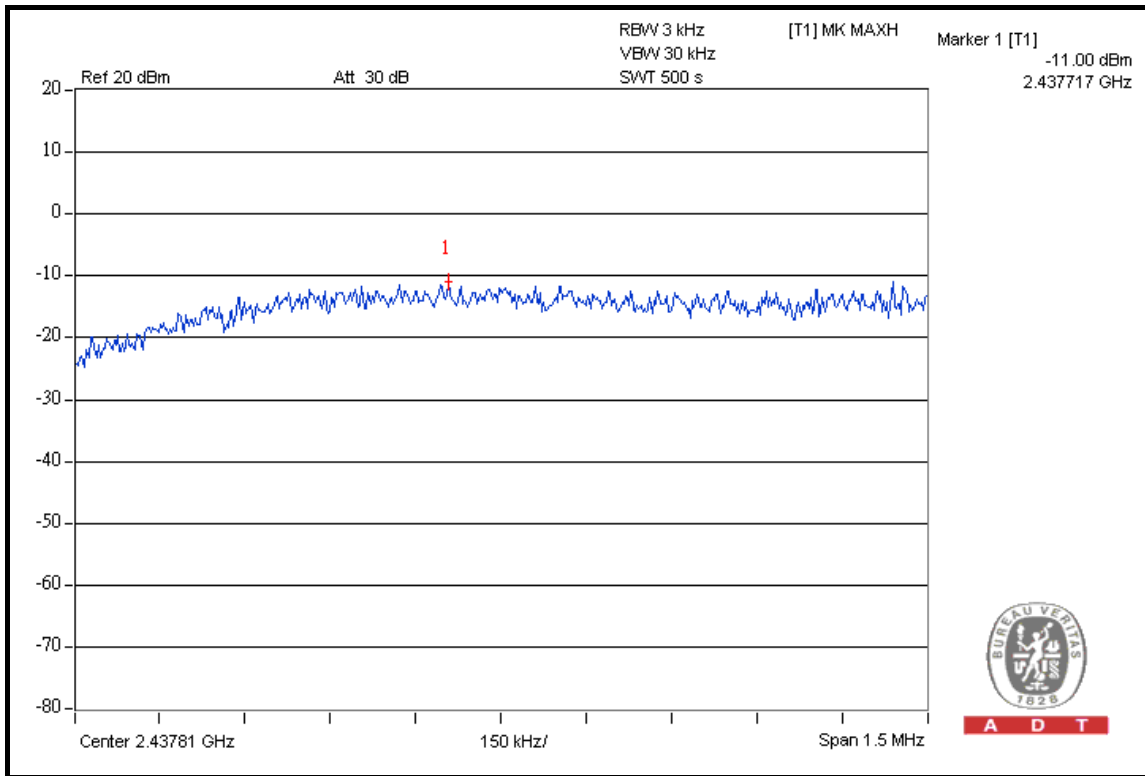

A D T

CH 11

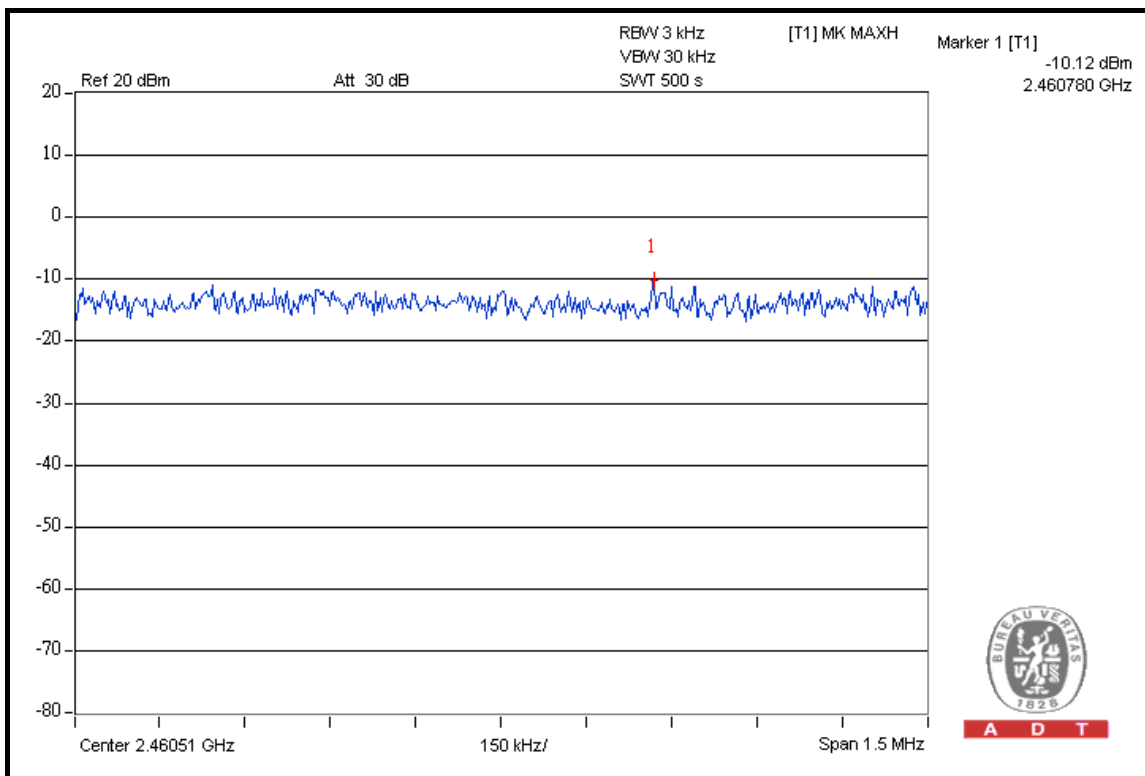

A D T



A D T

802.11g OFDM MODULATION

MODULATION TYPE	BPSK	TRANSFER RATE	6Mbps
INPUT POWER	120Vac, 60 Hz	ENVIRONMENTAL CONDITIONS	25deg. C, 66%RH, 1004hPa
TESTED BY	Antony Lee		

CHANNEL	CHANNEL FREQUENCY (MHz)	RF POWER LEVEL IN 3 kHz BW (dBm)	MAXIMUM LIMIT (dBm)	PASS/FAIL
1	2412	-11.69	8	PASS
6	2437	-11.79	8	PASS
11	2462	-11.44	8	PASS

CH 1

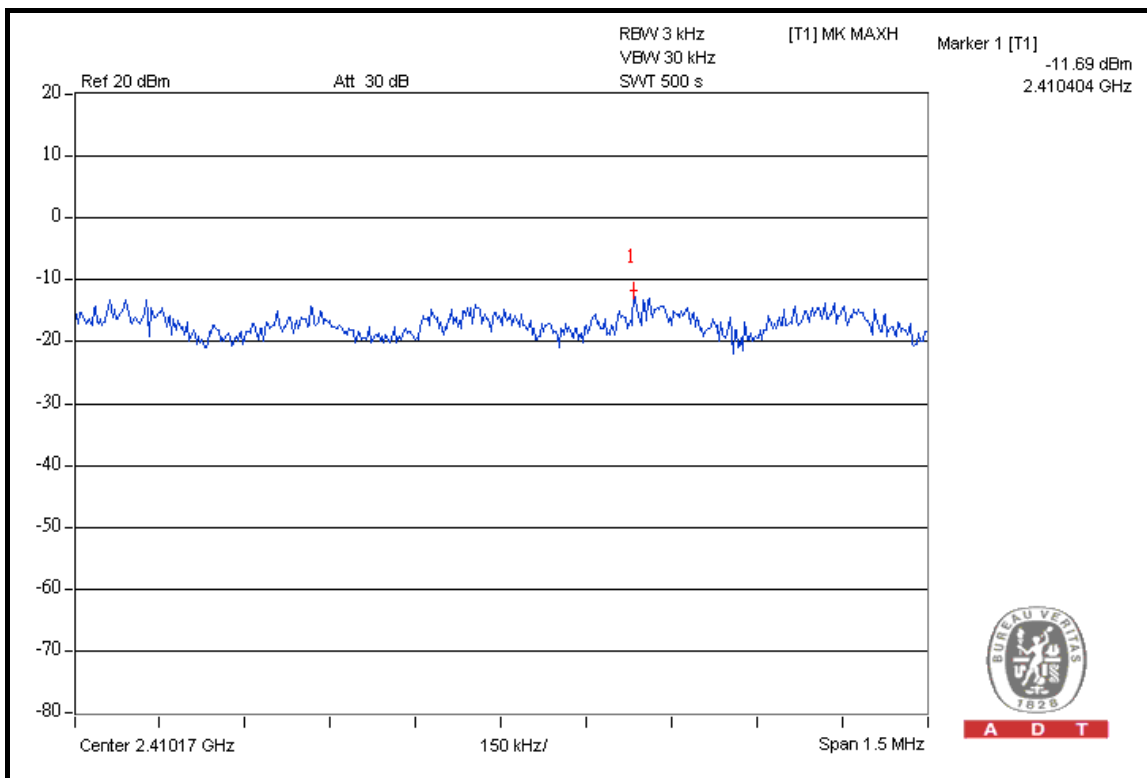

A D T



A D T

CH 6

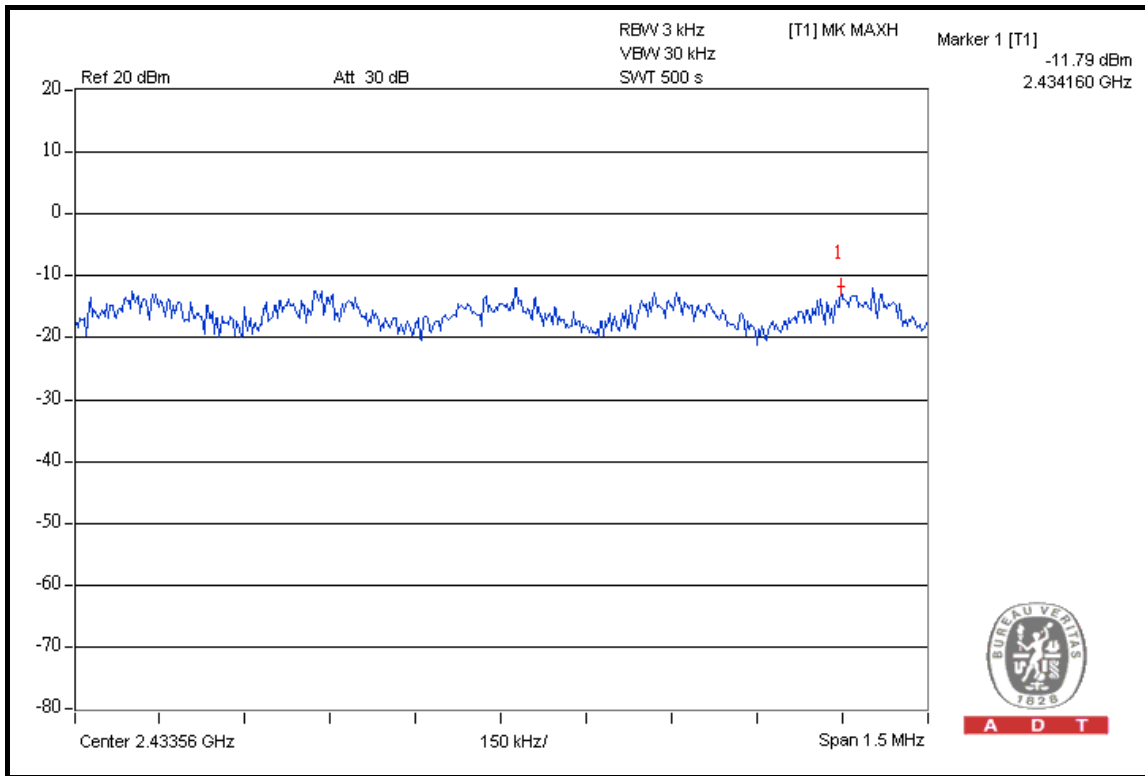

A D T

CH 11

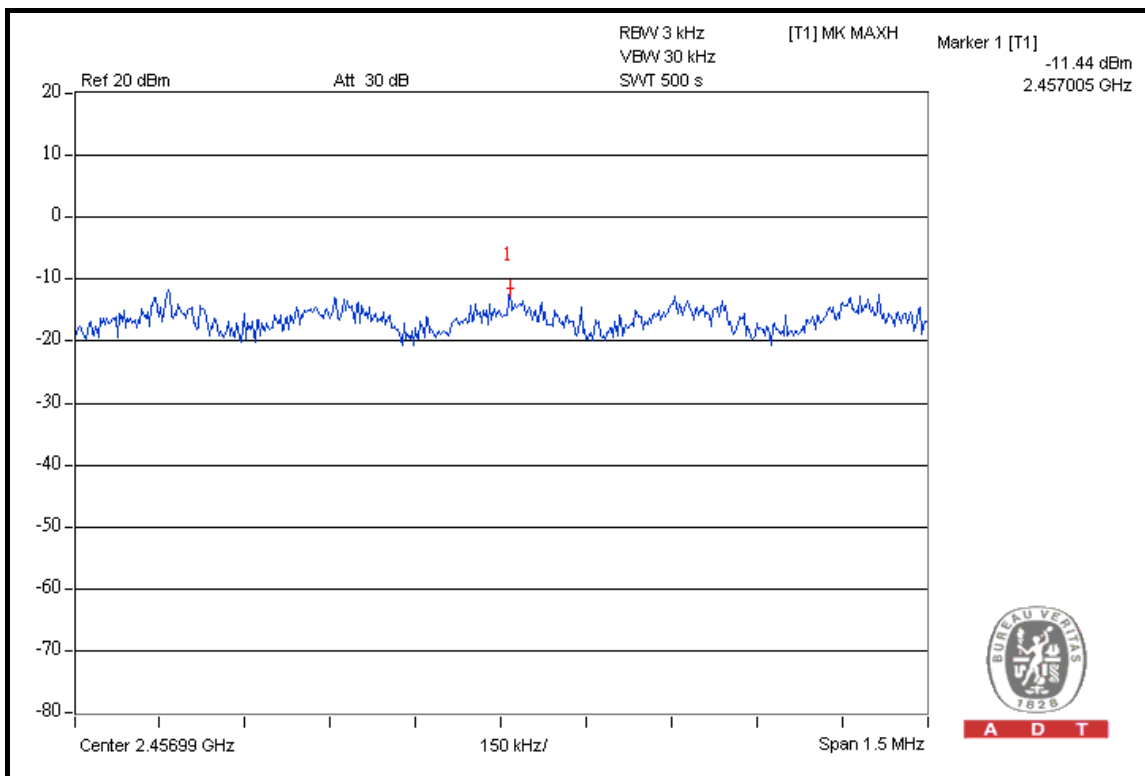

A D T

802.11g OFDM MODULATION (TURBO MODE)

4.6 BAND EDGES MEASUREMENT

4.6.1 LIMITS OF BAND EDGES MEASUREMENT

Below -20dB of the highest emission level of operating band (in 100kHz Resolution Bandwidth).

4.6.2 TEST INSTRUMENTS

DESCRIPTION & MANUFACTURER	MODEL NO.	SERIAL NO.	DATE OF CALIBRATION	DUE DATE OF CALIBRATION
SPECTRUM ANALYZER	FSP 40	100040	Jul. 04, 2008	Jul. 03, 2009

NOTE: The calibration interval of the above test instruments is 12 months and the calibrations are traceable to NML/ROC and NIST/USA.

4.6.3 TEST PROCEDURE

The transmitter output was connected to the spectrum analyzer via a low loss cable. Set both RBW and VBW of spectrum analyzer to 100kHz and 300kHz with suitable frequency span including 100MHz bandwidth from band edge. The band edges was measured and recorded.

The spectrum plots (Peak RBW=100kHz, VBW=300kHz; Average RBW=1MHz, VBW= 10Hz are attached on the following pages.

4.6.4 DEVIATION FROM TEST STANDARD

No deviation.

4.6.5 EUT OPERATING CONDITION

Same as 4.3.6.

4.6.6 TEST RESULTS

The spectrum plots are attached on the following 24 images. D1 line indicates the highest level, and D2 line indicates the 20dB offset below D1. It shows compliance with the requirement in part 15.247(d).

802.11b DSSS MODULATION TEST MODE A

NOTE 1: The band edge emission plot on the next second page shows 52.44dBc between carrier maximum power and local maximum emission in restrict band (2.34180GHz). The emission of carrier strength list in the test result of channel 1 at the item 4.1.7 is 114.89dBuV/m (Peak), so the maximum field strength in restrict band is $114.89 - 52.44 = 62.45$ dBuV/m which is under 74dBuV/m limit.

The band edge emission plot on the next second page shows 61.08Bc between carrier maximum power and local maximum emission in restrict band (2.39000GHz). The emission of carrier strength list in the test result of channel 1 at the item 4.1.7 is 109.81dBuV/m (Average), so the maximum field strength in restrict band is $109.81 - 61.08 = 48.73$ dBuV/m which is under 54dBuV/m limit.

NOTE 2: The band edge emission plot on the next third page shows 52.77dBc between carrier maximum power and local maximum emission in restrict band (2.49340GHz). The emission of carrier strength list in the test result of channel 11 at the item 4.1.7 is 113.00dBuV/m (Peak), so the maximum field strength in restrict band is $113.00 - 52.77 = 60.23$ dBuV/m which is under 74dBuV/m limit.

The band edge emission plot on the next fourth page shows 66.98dBc between carrier maximum power and local maximum emission in restrict band (2.48760GHz). The emission of carrier strength list in the test result of channel 11 at the item 4.1.7 is 108.29dBuV/m (Average), so the maximum field strength in restrict band is $108.29 - 66.98 = 41.31$ dBuV/m which is under 54dBuV/m limit.

802.11b DSSS MODULATION TEST MODE B

NOTE 1: The band edge emission plot on the next page shows 52.44dBc between carrier maximum power and local maximum emission in restrict band (2.34180GHz). The emission of carrier strength list in the test result of channel 1 at the item 4.1.7 is 111.65dBuV/m (Peak), so the maximum field strength in restrict band is $111.65 - 52.44 = 59.21$ dBuV/m which is under 74dBuV/m limit.

The band edge emission plot on the next page shows 61.08dBc between carrier maximum power and local maximum emission in restrict band (2.39000GHz). The emission of carrier strength list in the test result of channel 1 at the item 4.1.7 is 106.54dBuV/m (Average), so the maximum field strength in restrict band is $106.54 - 61.08 = 45.46$ dBuV/m which is under 54dBuV/m limit.

NOTE 2: The band edge emission plot on the next second page shows 52.77dBc between carrier maximum power and local maximum emission in restrict band (2.49340GHz). The emission of carrier strength list in the test result of channel 11 at the item 4.1.7 is 111.33dBuV/m (Peak), so the maximum field strength in restrict band is $111.33 - 52.77 = 58.56$ dBuV/m which is under 74dBuV/m limit.

The band edge emission plot on the next third page shows 66.98dBc between carrier maximum power and local maximum emission in restrict band (2.48760GHz). The emission of carrier strength list in the test result of channel 11 at the item 4.1.7 is 106.24dBuV/m (Average), so the maximum field strength in restrict band is $106.24 - 66.98 = 39.26$ dBuV/m which is under 54dBuV/m limit.



A D T

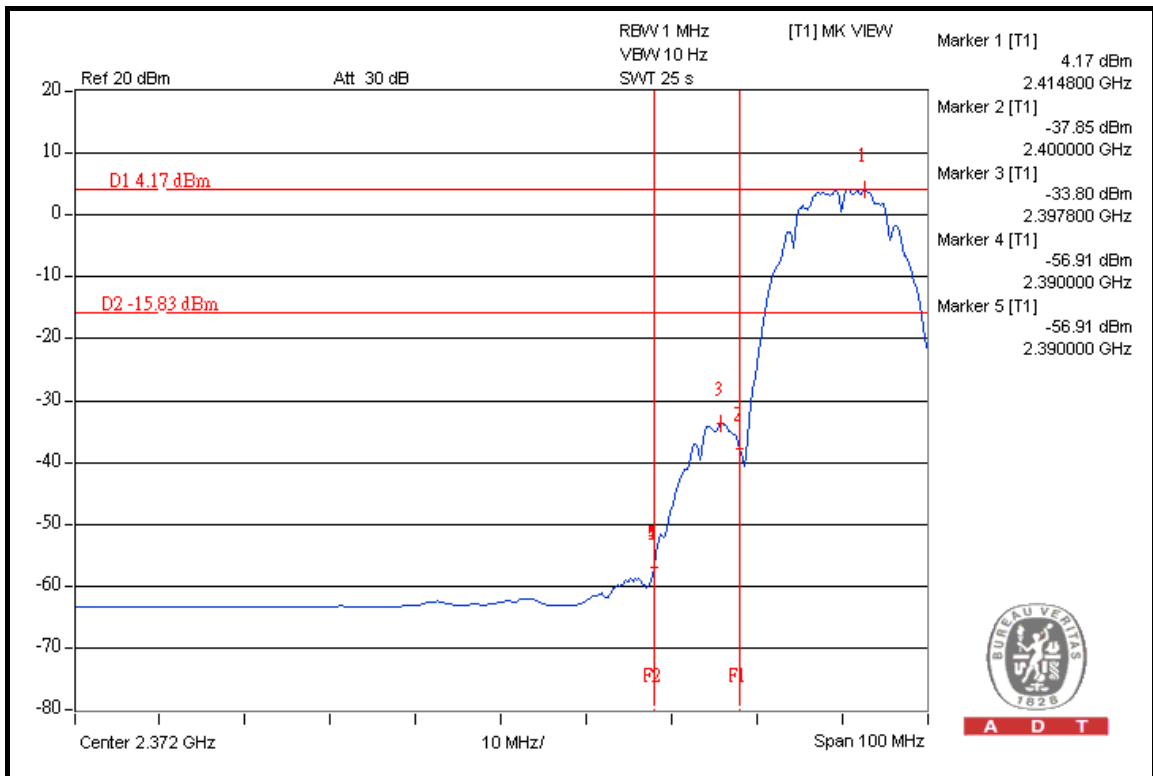
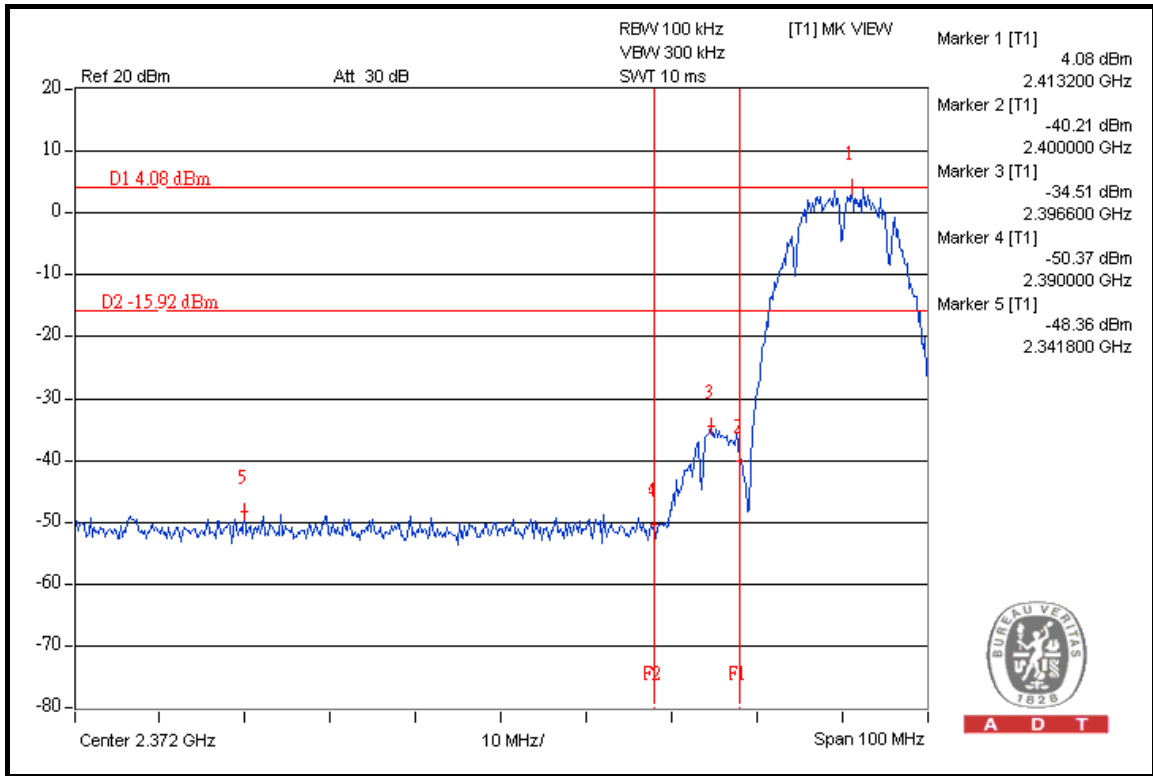



A D T

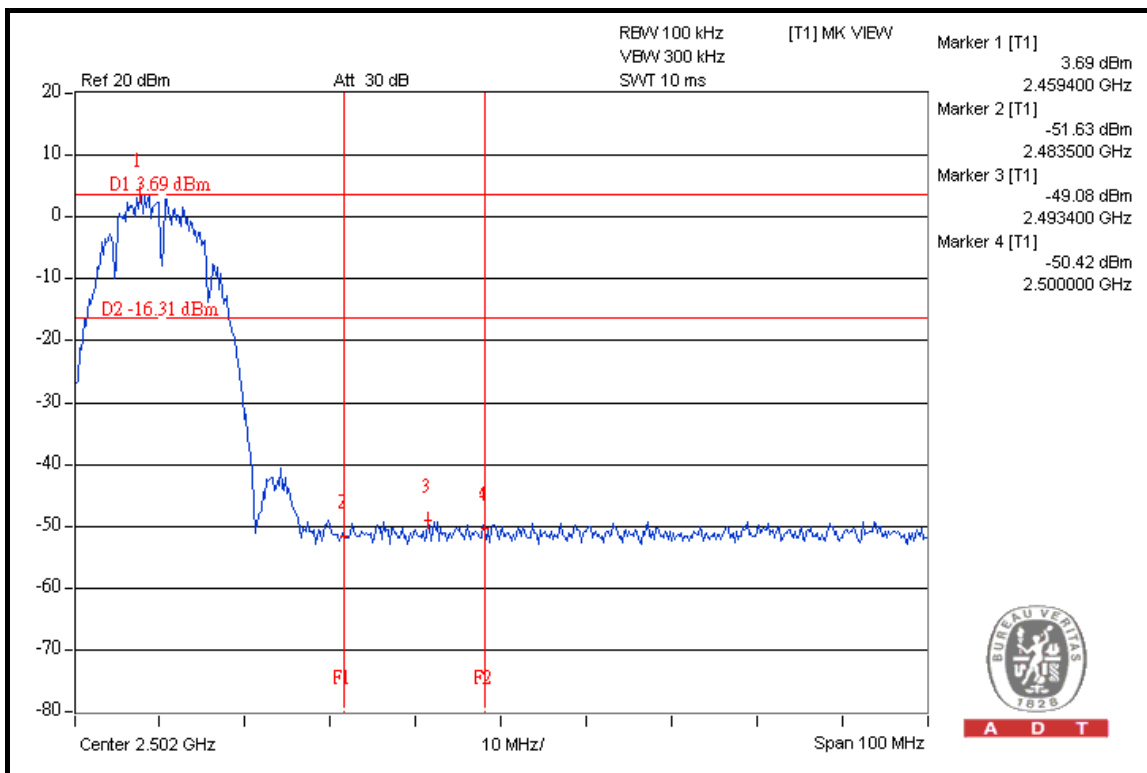
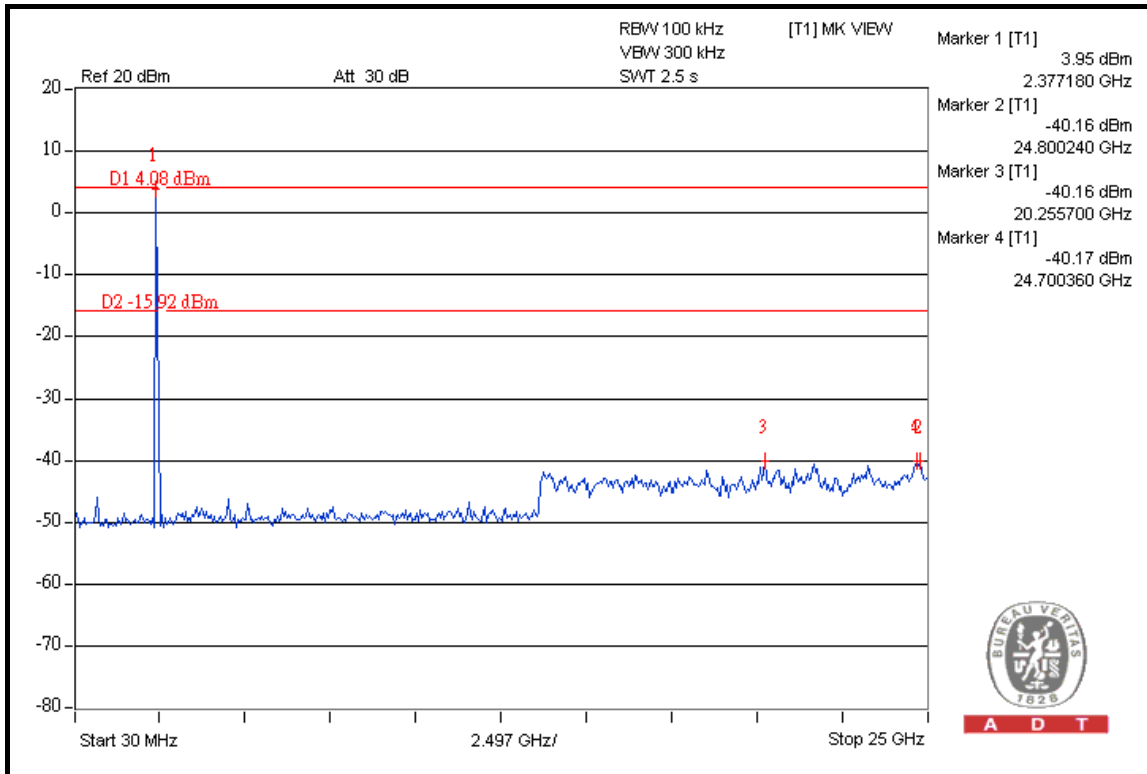



A D T

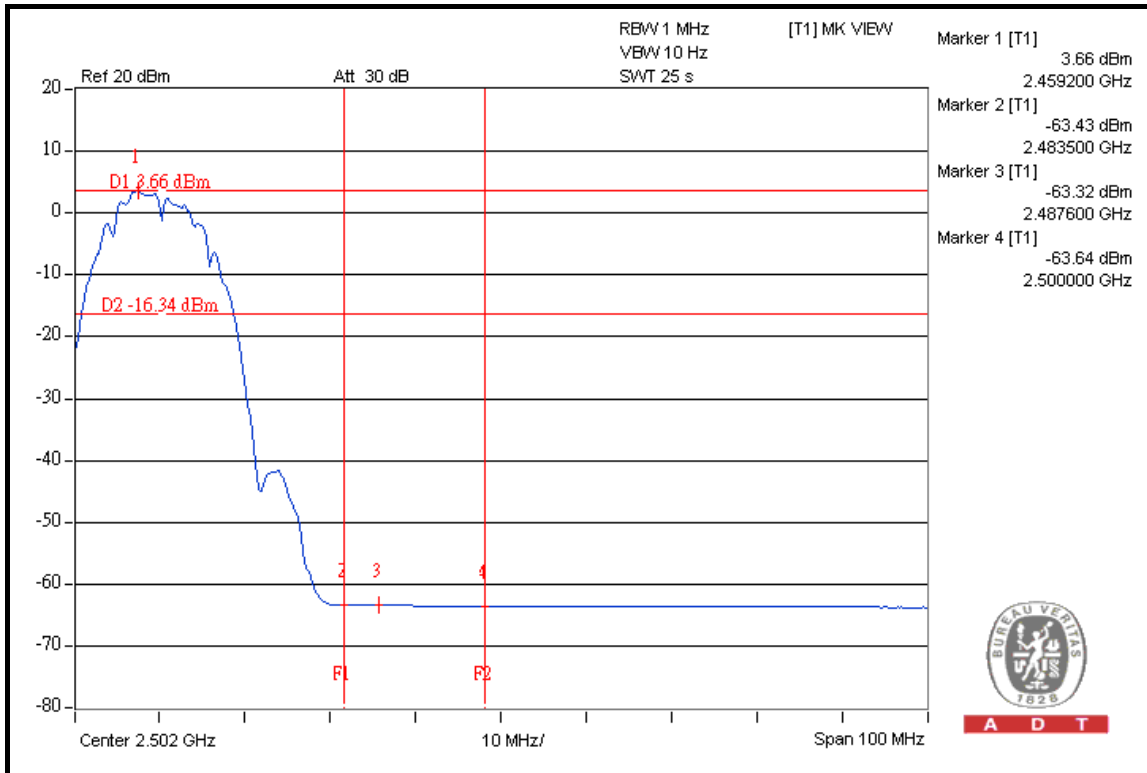

A D T

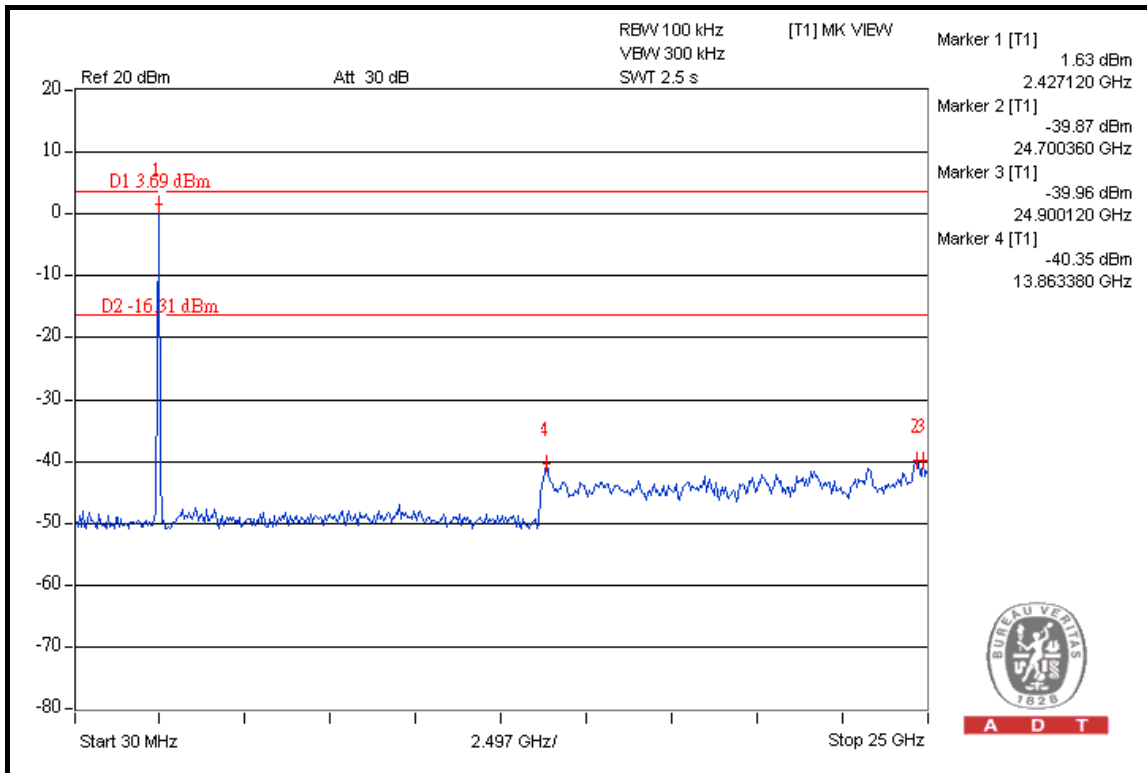

A D T

802.11g OFDM MODULATION TEST MODE A

NOTE 1: The band edge emission plot on the next second page shows 47.89dBc between carrier maximum power and local maximum emission in restrict band (2.38920GHz). The emission of carrier strength list in the test result of channel 1 at the item 4.1.7 is 116.82dBuV/m (Peak), so the maximum field strength in restrict band is $116.82 - 47.89 = 68.93$ dBuV/m which is under 74dBuV/m limit.

The band edge emission plot on the next second page shows 53.99dBc between carrier maximum power and local maximum emission in restrict band (2.39000GHz). The emission of carrier strength list in the test result of channel 1 at the item 4.1.7 is 106.63dBuV/m (Average), so the maximum field strength in restrict band is $106.63 - 53.99 = 52.64$ dBuV/m which is under 54dBuV/m limit.

NOTE 2: The band edge emission plot on the next third page shows 48.93dBc between carrier maximum power and local maximum emission in restrict band (2.49020GHz). The emission of carrier strength list in the test result of channel 11 at the item 4.1.7 is 115.81dBuV/m (Peak), so the maximum field strength in restrict band is $115.81 - 48.93 = 66.88$ dBuV/m which is under 74dBuV/m limit.

The band edge emission plot on the next fourth page shows 62.69dBc between carrier maximum power and local maximum emission in restrict band (2.48360GHz). The emission of carrier strength list in the test result of channel 11 at the item 4.1.7 is 105.58dBuV/m (Average), so the maximum field strength in restrict band is $105.58 - 62.69 = 42.89$ dBuV/m which is under 54dBuV/m limit.

802.11g OFDM MODULATION TEST MODE B

NOTE 1: The band edge emission plot on the next page shows 47.89dBc between carrier maximum power and local maximum emission in restrict band (2.38920GHz). The emission of carrier strength list in the test result of channel 1 at the item 4.1.7 is 113.62dBuV/m (Peak), so the maximum field strength in restrict band is $113.62 - 47.89 = 65.73$ dBuV/m which is under 74dBuV/m limit.

The band edge emission plot on the next page shows 53.99dBc between carrier maximum power and local maximum emission in restrict band (2.39000GHz). The emission of carrier strength list in the test result of channel 1 at the item 4.1.7 is 103.31dBuV/m (Average), so the maximum field strength in restrict band is $103.31 - 53.99 = 49.32$ dBuV/m which is under 54dBuV/m limit.

NOTE 2: The band edge emission plot on the next second page shows 48.93dBc between carrier maximum power and local maximum emission in restrict band (2.49020GHz). The emission of carrier strength list in the test result of channel 11 at the item 4.1.7 is 113.92dBuV/m (Peak), so the maximum field strength in restrict band is $113.92 - 48.93 = 64.99$ dBuV/m which is under 74dBuV/m limit.

The band edge emission plot on the next third page shows 62.69dBc between carrier maximum power and local maximum emission in restrict band (2.48360GHz). The emission of carrier strength list in the test result of channel 11 at the item 4.1.7 is 103.63dBuV/m (Average), so the maximum field strength in restrict band is $103.63 - 62.69 = 40.94$ dBuV/m which is under 54dBuV/m limit.



A D T

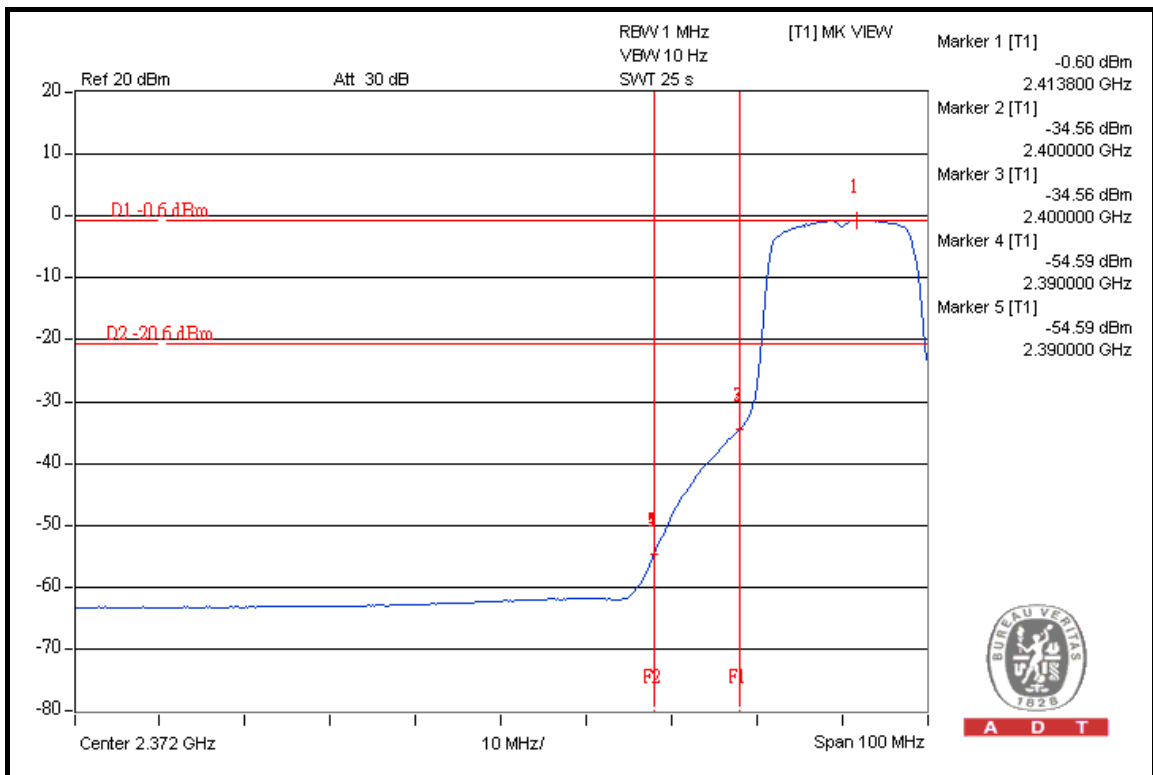
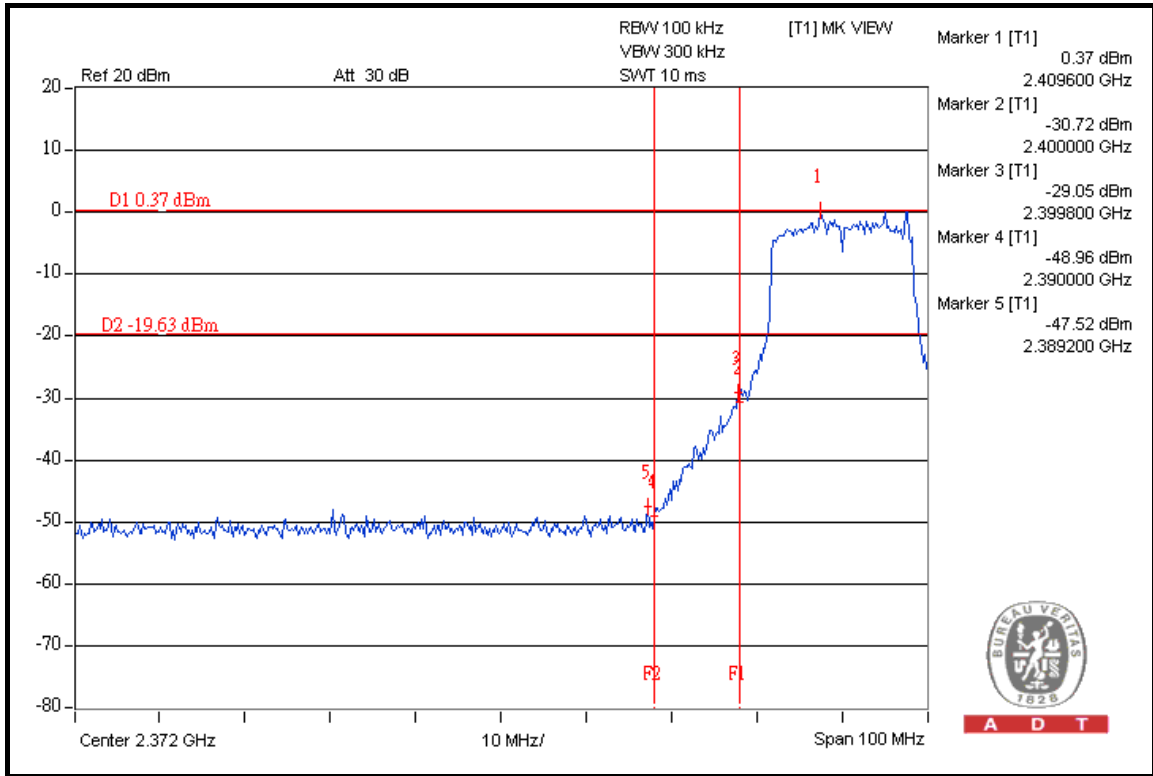



A D T

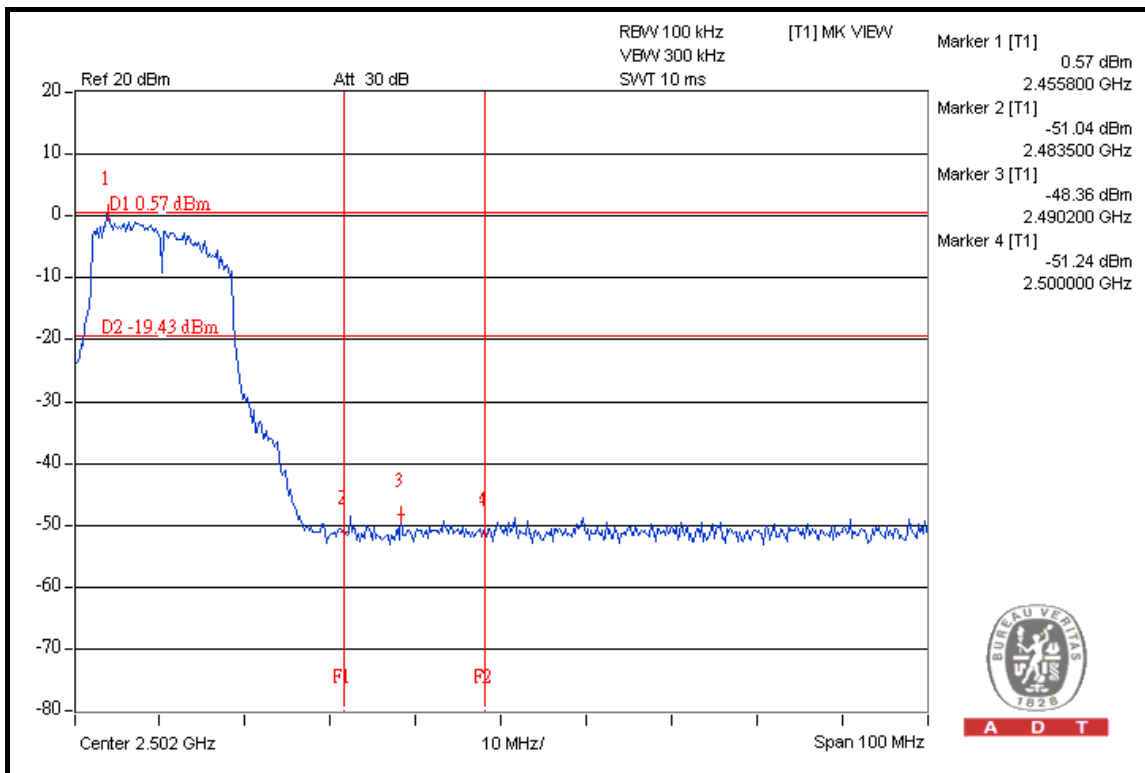
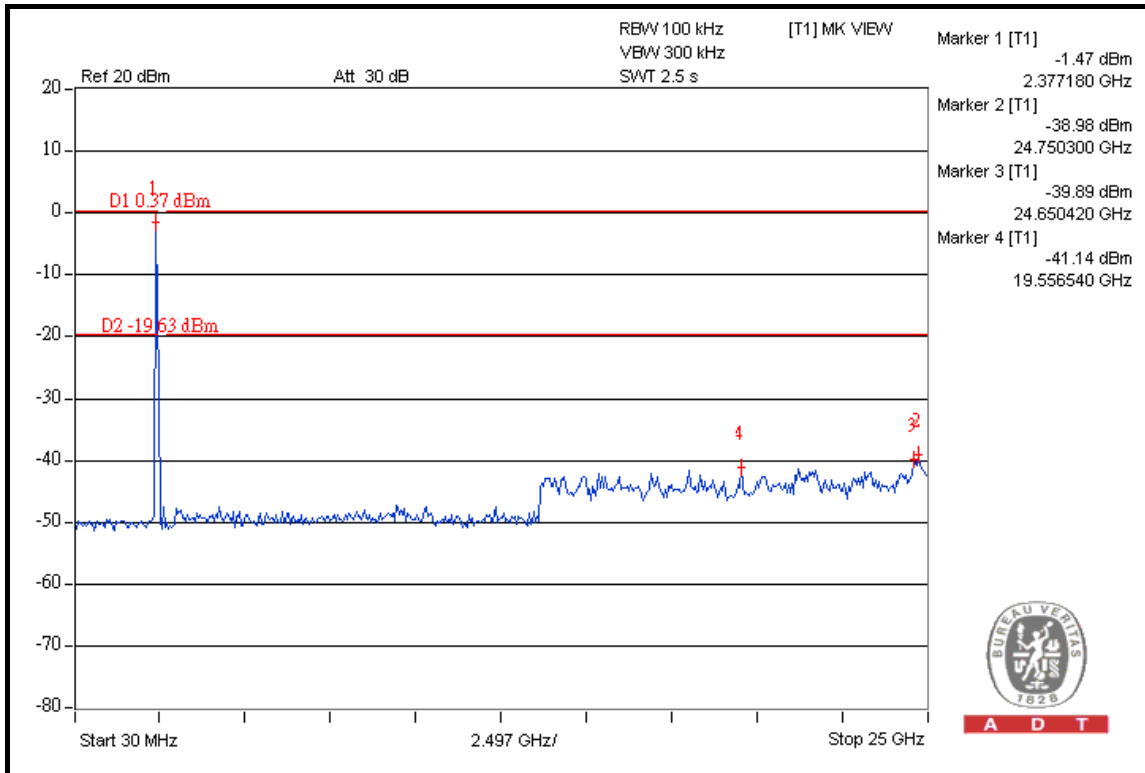



A D T

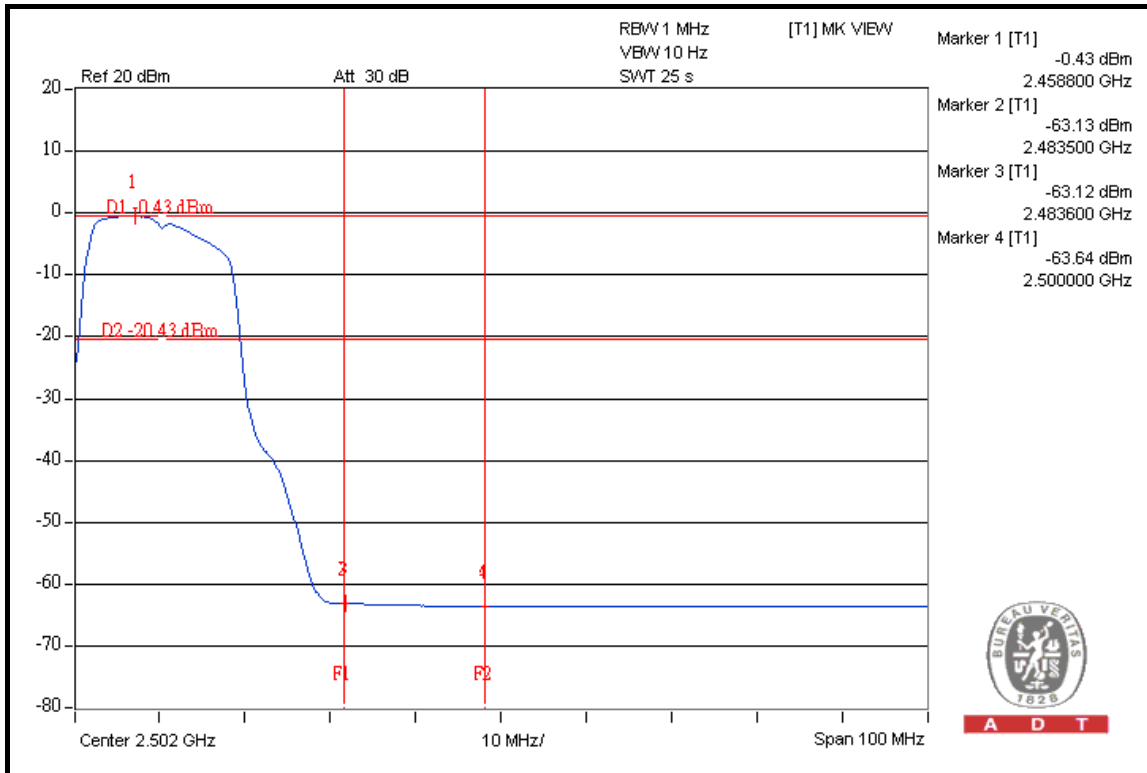

A D T

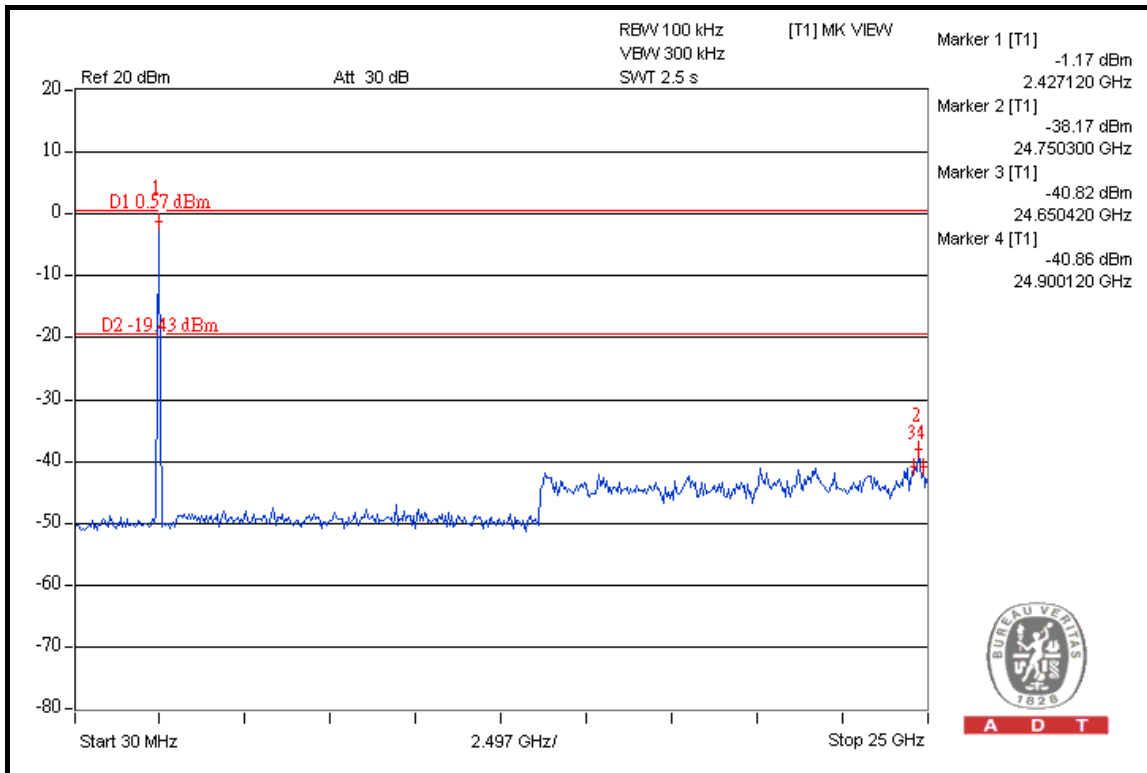

A D T

4.7 ANTENNA REQUIREMENT

4.7.1 STANDARD APPLICABLE

For intentional device, according to FCC 47 CFR Section 15.203, an intentional radiator shall be designed to ensure that no antenna other than that furnished by the responsible party shall be used with the device.

And according to FCC 47 CFR Section 15.247 (b), if transmitting antennas of directional gain greater than 6dBi are used, the power shall be reduced by the amount in dB that the directional gain of the antenna exceeds 6dBi.

4.7.2 ANTENNA CONNECTED CONSTRUCTION

The two kinds of antenna used in this product, one is Internal antenna (Patch) without antenna connector, the other is External antenna (dipole) with RSMA connector. The maximum Gain of the antenna is 7dBi.



A D T

5 PHOTOGRAPHS OF THE TEST CONFIGURATION

Please refer to the attached file (Test Setup Photo).

6 INFORMATION ON THE TESTING LABORATORIES

We, Bureau Veritas Consumer Products Services (H.K.) Ltd., Taoyuan Branch, were founded in 1988 to provide our best service in EMC, Radio, Telecom and Safety consultation. Our laboratories are accredited and approved by the following approval agencies according to ISO/IEC 17025.

USA	FCC, NVLAP
Germany	TUV Rheinland
Japan	VCCI
Norway	NEMKO
Canada	INDUSTRY CANADA , CSA
R.O.C.	TAF, BSMI, NCC
Netherlands	Telefication
Singapore	GOST-ASIA(MOU)
Russia	CERTIS(MOU)

Copies of accreditation certificates of our laboratories obtained from approval agencies can be downloaded from our web site:

www.adt.com.tw/index.5/phtml. If you have any comments, please feel free to contact us at the following:

Linko EMC/RF Lab:

Tel: 886-2-26052180
Fax: 886-2-26051924

Hsin Chu EMC/RF Lab:

Tel: 886-3-5935343
Fax: 886-3-5935342

Hwa Ya EMC/RF/Safety Telecom Lab:

Tel: 886-3-3183232
Fax: 886-3-3185050

Web Site: www.adt.com.tw

The address and road map of all our labs can be found in our web site also.



A D T

7 APPENDIX A – MODIFICATIONS RECORDERS FOR ENGINEERING CHANGES TO THE EUT BY THE LAB

No any modifications are made to the EUT by the lab during the test.

---END---