



A D T

FCC TEST REPORT

REPORT NO.: RF980117L05

MODEL NO.: ECB9500

RECEIVED: Jan. 17, 2009

TESTED: Jan. 21 ~ Feb. 05, 2009

ISSUED: Feb. 09, 2009

APPLICANT: Senao Networks Inc.

ADDRESS: 3F, No. 529, Chung Cheng Rd., Hsintien, Taipei,
Taiwan, R.O.C.

ISSUED BY: Bureau Veritas Consumer Products Services
(H.K.) Ltd., Taoyuan Branch

LAB ADDRESS: No. 47, 14th Ling, Chia Pau Tsuen, Lin Kou
Hsiang, Taipei Hsien 244, Taiwan, R.O.C.

TEST LOCATION: No. 19, Hwa Ya 2nd Rd, Wen Hwa Tsuen, Kwei
Shan Hsiang, Taoyuan Hsien 333, Taiwan,
R.O.C.

This test report consists of 92 pages in total. It may be duplicated completely for legal use with the approval of the applicant. It should not be reproduced except in full, without the written approval of our laboratory. The client should not use it to claim product endorsement by TAF or any government agencies. The test results in the report only apply to the tested sample.





TABLE OF CONTENTS

1.	CERTIFICATION.....	4
2.	SUMMARY OF TEST RESULTS.....	5
2.1	MEASUREMENT UNCERTAINTY	5
3.	GENERAL INFORMATION.....	6
3.1	GENERAL DESCRIPTION OF EUT	6
3.2	DESCRIPTION OF TEST MODES	7
3.2.1	CONFIGURATION OF SYSTEM UNDER TEST.....	8
3.2.2	TEST MODE APPLICABILITY AND TESTED CHANNEL DETAIL.....	10
3.3	GENERAL DESCRIPTION OF APPLIED STANDARDS.....	12
3.4	DESCRIPTION OF SUPPORT UNITS	12
4.	TEST TYPES AND RESULTS.....	13
4.1	RADIATED EMISSION MEASUREMENT.....	13
4.1.1	LIMITS OF RADIATED EMISSION MEASUREMENT	13
4.1.2	TEST INSTRUMENTS.....	14
4.1.3	TEST PROCEDURES	15
4.1.4	DEVIATION FROM TEST STANDARD	15
4.1.5	TEST SETUP.....	16
4.1.6	EUT OPERATING CONDITIONS	16
4.1.7	TEST RESULTS	17
4.2	CONDUCTED EMISSION MEASUREMENT.....	31
4.2.1	LIMITS OF CONDUCTED EMISSION MEASUREMENT	31
4.2.2	TEST INSTRUMENTS.....	31
4.2.3	TEST PROCEDURES	32
4.2.4	DEVIATION FROM TEST STANDARD	32
4.2.5	TEST SETUP.....	33
4.2.6	EUT OPERATING CONDITIONS	33
4.2.7	TEST RESULTS	34
4.3	6dB BANDWIDTH MEASUREMENT	38
4.3.1	LIMITS OF 6dB BANDWIDTH MEASUREMENT	38
4.3.2	TEST INSTRUMENTS.....	38
4.3.3	TEST PROCEDURE.....	38
4.3.4	DEVIATION FROM TEST STANDARD.....	38
4.3.5	TEST SETUP.....	39
4.3.6	EUT OPERATING CONDITIONS	39
4.3.7	TEST RESULTS	40
4.4	MAXIMUM PEAK OUTPUT POWER.....	52
4.4.1	LIMITS OF MAXIMUM PEAK OUTPUT POWER MEASUREMENT.....	52
4.4.2	INSTRUMENTS	52
4.4.3	TEST PROCEDURES	52
4.4.4	DEVIATION FROM TEST STANDARD	53
4.4.5	TEST SETUP.....	53
4.4.6	EUT OPERATING CONDITIONS	53
4.4.7	TEST RESULTS	54
4.5	POWER SPECTRAL DENSITY MEASUREMENT	56
4.5.1	LIMITS OF POWER SPECTRAL DENSITY MEASUREMENT	56



A D T

4.5.2	TEST INSTRUMENTS	56
4.5.3	TEST PROCEDURE	56
4.5.4	DEVIATION FROM TEST STANDARD	57
4.5.5	TEST SETUP	57
4.5.6	EUT OPERATING CONDITION	57
4.5.7	TEST RESULTS	58
4.6	BAND EDGES MEASUREMENT	70
4.6.1	LIMITS OF BAND EDGES MEASUREMENT	70
4.6.2	TEST INSTRUMENTS	70
4.6.3	TEST PROCEDURE	71
4.6.4	DEVIATION FROM TEST STANDARD	72
4.6.5	EUT OPERATING CONDITION	72
4.6.6	TEST RESULTS	73
4.7	ANTENNA REQUIREMENT	89
4.7.1	STANDARD APPLICABLE	89
4.7.2	ANTENNA CONNECTED CONSTRUCTION	89
5.	PHOTOGRAPHS OF THE TEST CONFIGURATION	90
6.	INFORMATION ON THE TESTING LABORATORIES	91
7.	APPENDIX A - MODIFICATIONS RECORDERS FOR ENGINEERING CHANGES TO THE EUT BY THE LAB	92



A D T

1. CERTIFICATION

PRODUCT: 11N Wireless Gigabit Client Bridge

MODEL: ECB9500

BRAND: EnGenius

APPLICANT: Senao Networks Inc.

TEST SAMPLE: ENGINEERING SAMPLE

TESTED: Jan. 21 ~ Feb. 05, 2009

STANDARDS: FCC Part 15, Subpart C (Section 15.247)

ANSI C63.4-2003

The above equipment (Model: ECB9500) has been tested by **Bureau Veritas Consumer Products Services (H.K.) Ltd., Taoyuan Branch**, and found compliance with the requirement of the above standards. The test record, data evaluation & Equipment Under Test (EUT) configurations represented herein are true and accurate accounts of the measurements of the sample's EMC characteristics under the conditions specified in this report.

PREPARED BY : Peggy Chen , **DATE:** Feb. 09, 2009
Peggy Chen / Specialist

TECHNICAL ACCEPTANCE : Long Chen , **DATE:** Feb. 09, 2009
Responsible for RF Long Chen / Senior Engineer

APPROVED BY : Gary Chang , **DATE:** Feb. 09, 2009
Gary Chang / Assistant Manager



2. SUMMARY OF TEST RESULTS

The EUT has been tested according to the following specifications:

APPLIED STANDARD: FCC PART 15, SUBPART C (SECTION 15.247)			
STANDARD SECTION	TEST TYPE AND LIMIT	RESULT	REMARK
15.207	AC Power Conducted Emission	PASS	Meet the requirement of limit. Minimum passing margin is -20.90dB at 4.164MHz.
15.247(a)(2)	Spectrum Bandwidth of a Direct Sequence Spread Spectrum System Limit: min. 500kHz	PASS	Meet the requirement of limit.
15.247(b)	Maximum Peak Output Power Limit: max. 30dBm	PASS	Meet the requirement of limit.
15.247(d)	Radiated Emissions Limit: Table 15.209	PASS	Meet the requirement of limit. Minimum passing margin is -1.01dB at 1000.00MHz.
15.247(e)	Power Spectral Density Limit: max. 8dBm	PASS	Meet the requirement of limit.
15.247(d)	Band Edge Measurement Limit: 20dB less than the peak value of fundamental frequency	PASS	Meet the requirement of limit.

2.1 MEASUREMENT UNCERTAINTY

Where relevant, the following measurement uncertainty levels have been estimated for tests performed on the EUT as specified in CISPR 16-4-2:

MEASUREMENT	FREQUENCY	UNCERTAINTY
Conducted emissions	9kHz~30MHz	2.44 dB
Radiated emissions	30MHz ~ 200MHz	3.34 dB
	200MHz ~1000MHz	3.35 dB
	1GHz ~ 18GHz	2.26 dB
	18GHz ~ 40GHz	1.94 dB

This uncertainty represents an expanded uncertainty expressed at approximately the 95% confidence level using a coverage factor of $k = 2$.



3. GENERAL INFORMATION

3.1 GENERAL DESCRIPTION OF EUT

EUT	11N Wireless Gigabit Client Bridge
MODEL NO.	ECB9500
FCC ID	U2M-CB97508001
POWER SUPPLY	12Vdc from adapter 48Vdc from internal POE
MODULATION TYPE	CCK, DQPSK, DBPSK for DSSS 64QAM, 16QAM, QPSK, BPSK for OFDM
MODULATION TECHNOLOGY	DSSS, OFDM
TRANSFER RATE	802.11b: 11.0/ 5.5/ 2.0/ 1.0Mbps 802.11g: 54.0/ 48.0/ 36.0/ 24.0/ 18.0/ 12.0/ 9.0/ 6.0Mbps Draft 802.11n: up to 300.0Mbps
FREQUENCY RANGE	2400.0 ~ 2483.5MHz
NUMBER OF CHANNEL	11 for 802.11b, 802.11g, draft 802.11n (20MHz) 7 for draft 802.11n (40MHz)
OUTPUT POWER	228.034mW
ANTENNA TYPE	Dipole antenna with 5dBi gain
DATA CABLE	NA
I/O PORTS	RJ45
ACCESSORY DEVICE	Adapter

NOTE:

1. The EUT was tested with the following adapter:

BRAND :	AMIGO
MODEL :	AMS6-1201000SU
INPUT :	120Vac, 60Hz, 0.5A
OUTPUT :	12Vdc, 1.0A
POWER LINE :	1.8m non-shielded cable without core

2. The EUT incorporates a MIMO function. Physically, the EUT provides two completed transmitters and three receivers.

MODULATION MODE	TX FUNCTION
802.11b	1TX
802.11g	1TX
Draft 802.11n (20MHz)	2TX
Draft 802.11n (40MHz)	2TX

3. The above EUT information was declared by manufacturer and for more detailed features description, please refer to the manufacturer's specifications or user's manual.

3.2 DESCRIPTION OF TEST MODES

11 channels are provided for 802.11b, 802.11g and draft 802.11n (20MHz):

CHANNEL	FREQUENCY	CHANNEL	FREQUENCY
1	2412MHz	7	2442MHz
2	2417MHz	8	2447MHz
3	2422MHz	9	2452MHz
4	2427MHz	10	2457MHz
5	2432MHz	11	2462MHz
6	2437MHz		

7 channels are provided for draft 802.11n (40MHz):

CHANNEL	FREQUENCY	CHANNEL	FREQUENCY
1	2422MHz	5	2442MHz
2	2427MHz	6	2447MHz
3	2432MHz	7	2452MHz
4	2437MHz		

3.2.1 CONFIGURATION OF SYSTEM UNDER TEST

Test Mode A

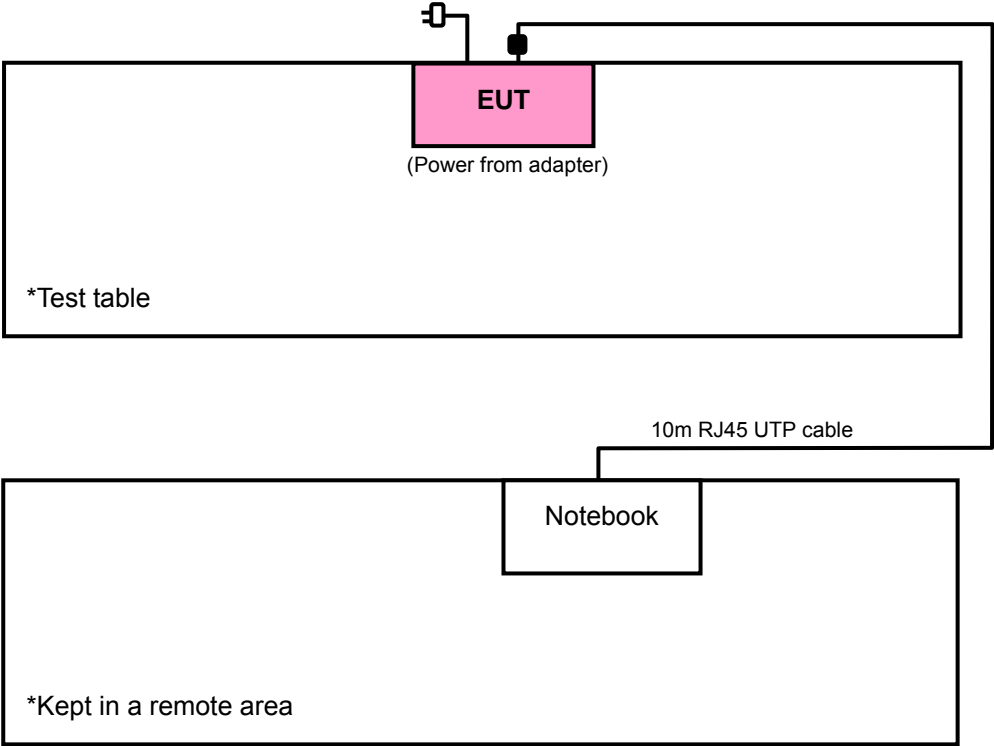



Test Mode B

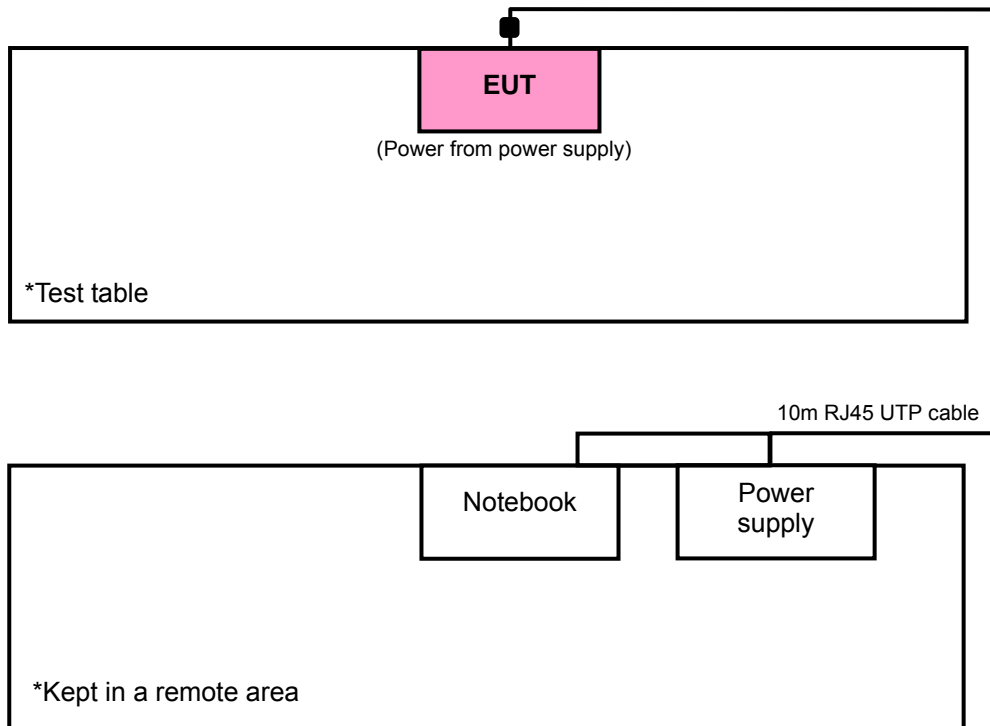



3.2.2 TEST MODE APPLICABILITY AND TESTED CHANNEL DETAIL

EUT CONFIGURE MODE	APPLICABLE TO				DESCRIPTION
	RE≥1G	RE<1G	PLC	APCM	
A	√	√	√	√	Power from adapter
B	-	√	√	-	Power from internal POE

Where **RE≥1G**: Radiated Emission above 1GHz **RE<1G**: Radiated Emission below 1GHz
PLC: Power Line Conducted Emission **APCM**: Antenna Port Conducted Measurement

NOTE: “-”: Means no effect.

RADIATED EMISSION TEST (ABOVE 1GHz):

- Pre-Scan has been conducted to determine the worst-case mode from all possible combinations between available modulations, data rates, XYZ axis and antenna ports (if EUT with antenna diversity architecture).
- Following channel(s) was (were) selected for the final test as listed below.

EUT CONFIGURE MODE	MODE	AVAILABLE CHANNEL	TESTED CHANNEL	MODULATION TECHNOLOGY	MODULATION TYPE	DATA RATE (Mbps)	AXIS
A	802.11b	1 to 11	1, 6, 11	DSSS	DBPSK	1.0	Z
A	802.11g	1 to 11	1, 6, 11	OFDM	BPSK	6.0	Z
A	Draft 802.11n (20MHz)	1 to 11	1, 6, 11	OFDM	BPSK	7.2	Z
A	Draft 802.11n (40MHz)	1 to 7	1, 4, 7	OFDM	BPSK	15.0	Z

RADIATED EMISSION TEST (BELOW 1GHz):

- Pre-Scan has been conducted to determine the worst-case mode from all possible combinations between available modulations, data rates, XYZ axis and antenna ports (if EUT with antenna diversity architecture).
- Following channel(s) was (were) selected for the final test as listed below.

EUT CONFIGURE MODE	MODE	AVAILABLE CHANNEL	TESTED CHANNEL	MODULATION TECHNOLOGY	MODULATION TYPE	DATA RATE (Mbps)	AXIS
A	802.11g	1 to 11	6	OFDM	BPSK	6.0	Z
B	802.11g	1 to 11	6	OFDM	BPSK	6.0	Z

**POWER LINE CONDUCTED EMISSION TEST:**

- Pre-Scan has been conducted to determine the worst-case mode from all possible combinations between available modulations, data rates and antenna ports (if EUT with antenna diversity architecture).
- Following channel(s) was (were) selected for the final test as listed below.

EUT CONFIGURE MODE	MODE	AVAILABLE CHANNEL	TESTED CHANNEL	MODULATION TECHNOLOGY	MODULATION TYPE	DATA RATE (Mbps)
A	802.11g	1 to 11	6	OFDM	BPSK	6.0
B	802.11g	1 to 11	6	OFDM	BPSK	6.0

BANDEDGE MEASUREMENT:

- Pre-Scan has been conducted to determine the worst-case mode from all possible combinations between available modulations, data rates, XYZ axis and antenna ports (if EUT with antenna diversity architecture).
- Following channel(s) was (were) selected for the final test as listed below.

EUT CONFIGURE MODE	MODE	AVAILABLE CHANNEL	TESTED CHANNEL	MODULATION TECHNOLOGY	MODULATION TYPE	DATA RATE (Mbps)	AXIS
A	802.11b	1 to 11	1, 11	DSSS	DBPSK	1.0	Z
A	802.11g	1 to 11	1, 11	OFDM	BPSK	6.0	Z
A	Draft 802.11n (20MHz)	1 to 11	1, 11	OFDM	BPSK	7.2	Z
A	Draft 802.11n (40MHz)	1 to 7	1, 7	OFDM	BPSK	15.0	Z

ANTENNA PORT CONDUCTED MEASUREMENT:

- Pre-Scan has been conducted to determine the worst-case mode from all possible combinations between available modulations, data rates and antenna ports (if EUT with antenna diversity architecture).
- Following channel(s) was (were) selected for the final test as listed below.

EUT CONFIGURE MODE	MODE	AVAILABLE CHANNEL	TESTED CHANNEL	MODULATION TECHNOLOGY	MODULATION TYPE	DATA RATE (Mbps)
A	802.11b	1 to 11	1, 6, 11	DSSS	DBPSK	1.0
A	802.11g	1 to 11	1, 6, 11	OFDM	BPSK	6.0
A	Draft 802.11n (20MHz)	1 to 11	1, 6, 11	OFDM	BPSK	7.2
A	Draft 802.11n (40MHz)	1 to 7	1, 4, 7	OFDM	BPSK	15.0



A D T

3.3 GENERAL DESCRIPTION OF APPLIED STANDARDS

The EUT is a RF Product. According to the specifications of the manufacturer, it must comply with the requirements of the following standards:

FCC Part 15, Subpart C (15.247)

ANSI C63.4-2003

All test items have been performed and recorded as per the above standards.

NOTE: The EUT is also considered as a kind of computer peripheral, because the connection to computer is necessary for typical use. It has been verified to comply with the requirements of FCC Part 15, Subpart B, Class B (DoC). The test report has been issued separately.

3.4 DESCRIPTION OF SUPPORT UNITS

The EUT has been tested as an independent unit together with other necessary accessories or support units. The following support units or accessories were used to form a representative test configuration during the tests.

NO.	PRODUCT	BRAND	MODEL NO.	SERIAL NO.	FCC ID
1	NOTEBOOK COMPUTER	DELL	PP05L	16484462992	E2K24CLNS
2	POWER SUPPLY	TOP WARD	6603A	725906	NA

NO.	SIGNAL CABLE DESCRIPTION OF THE ABOVE SUPPORT UNITS
1	NA
2	10m RJ45 UTP cable with one core

NOTE: 1. All power cords of the above support units are non shielded (1.8m).
2. Item 1, 2 acted as communication partners to transfer data.



4. TEST TYPES AND RESULTS

4.1 RADIATED EMISSION MEASUREMENT

4.1.1 LIMITS OF RADIATED EMISSION MEASUREMENT

Emissions radiated outside of the specified bands, shall be according to the general radiated limits in 15.209 as following:

FREQUENCIES (MHz)	FIELD STRENGTH (microvolts/meter)	MEASUREMENT DISTANCE (meters)
0.009 ~ 0.490	2400/F(kHz)	300
0.490 ~ 1.705	24000/F(kHz)	30
1.705 ~ 30.0	30	30
30 ~ 88	100	3
88 ~ 216	150	3
216 ~ 960	200	3
Above 960	500	3

NOTE:

1. The lower limit shall apply at the transition frequencies.
2. Emission level (dBuV/m) = 20 log Emission level (uV/m).
3. As shown in 15.35(b), for frequencies above 1000MHz, the field strength limits are based on average detector, however, the peak field strength of any emission shall not exceed the maximum permitted average limits, specified above by more than 20dB under any condition of modulation.



A D T

4.1.2 TEST INSTRUMENTS

DESCRIPTION & MANUFACTURER	MODEL NO.	SERIAL NO.	DATE OF CALIBRATION	DUE DATE OF CALIBRATION
Test Receiver ROHDE & SCHWARZ	ESI7	100033	Jun. 30, 2008	Jun. 29, 2009
Spectrum Analyzer ROHDE & SCHWARZ	FSP40	100041	Apr. 22, 2008	Apr. 21, 2009
BILOG Antenna SCHWARZBECK	VULB9168	9168-160	May 02, 2008	May 01, 2009
HORN Antenna SCHWARZBECK	9120D	9120D-209	Jun. 24, 2008	Jun. 23, 2009
HORN Antenna SCHWARZBECK	BBHA 9170	BBHA9170243	Dec. 25, 2008	Dec. 24, 2009
Preamplifier Agilent	8447D	2944A10633	Nov. 03, 2008	Nov. 02, 2009
Preamplifier Agilent	8449B	3008A01964	Oct. 23, 2008	Oct. 22, 2009
RF signal cable HUBER+SUHNNER	SUCOFLEX 104	238141/4	May 20, 2008	May 19, 2009
RF signal cable HUBER+SUHNNER	SUCOFLEX 104	12738/6	May 20, 2008	May 19, 2009
Software ADT.	ADT_Radiated_ V7.6.15.9.2	NA	NA	NA
Antenna Tower inn-co GmbH	MA 4000	013303	NA	NA
Antenna Tower Controller inn-co GmbH	CO2000	017303	NA	NA
Turn Table ADT.	TT100.	TT93021703	NA	NA
Turn Table Controller ADT.	SC100.	SC93021703	NA	NA

- NOTE:** 1. The calibration interval of the above test instruments is 12 months and the calibrations are traceable to NML/ROC and NIST/USA.
2. The test was performed in HwaYa Chamber 3.
3. The horn antenna and HP preamplifier (model: 8449B) are used only for the measurement of emission frequency above 1GHz if tested.
4. The FCC Site Registration No. is 988962.
5. The IC Site Registration No. is IC 7450F-3.



4.1.3 TEST PROCEDURES

- a. The EUT was placed on the top of a rotating table 0.8 meters above the ground at a 3 meters semi-anechoic chamber. The table was rotated 360 degrees to determine the position of the highest radiation.
- b. The EUT was set 3 meters away from the interference-receiving antenna, which was mounted on the top of a variable-height antenna tower.
- c. The antenna is a broadband antenna, and its height is varied from one meter to four meters above the ground to determine the maximum value of the field strength. Both horizontal and vertical polarizations of the antenna are set to make the measurement.
- d. For each suspected emission, the EUT was arranged to its worst case and then the antenna was tuned to heights from 1 meter to 4 meters and the rotatable table was turned from 0 degrees to 360 degrees to find the maximum reading.
- e. The test-receiver system was set to Peak Detect Function and Specified Bandwidth with Maximum Hold Mode.
- f. If the emission level of the EUT in peak mode was lower than the limit specified, then testing could be stopped and the peak values of the EUT would be reported. Otherwise the emissions would be re-tested one by one using peak, quasi-peak or average method as specified and then reported in a data sheet.

NOTE:

1. The resolution bandwidth and video bandwidth of test receiver/spectrum analyzer is 120kHz for Quasi-peak detection at frequency below 1GHz.
2. The resolution bandwidth of test receiver/spectrum analyzer is 1MHz and video bandwidth is 3MHz for Peak detection at frequency above 1GHz.
3. The resolution bandwidth of test receiver/spectrum analyzer is 1MHz and the video bandwidth is 10Hz for Average detection (AV) at frequency above 1GHz.
4. All modes of operation were investigated and the worst-case emissions are reported.

4.1.4 DEVIATION FROM TEST STANDARD

No deviation.

4.1.5 TEST SETUP

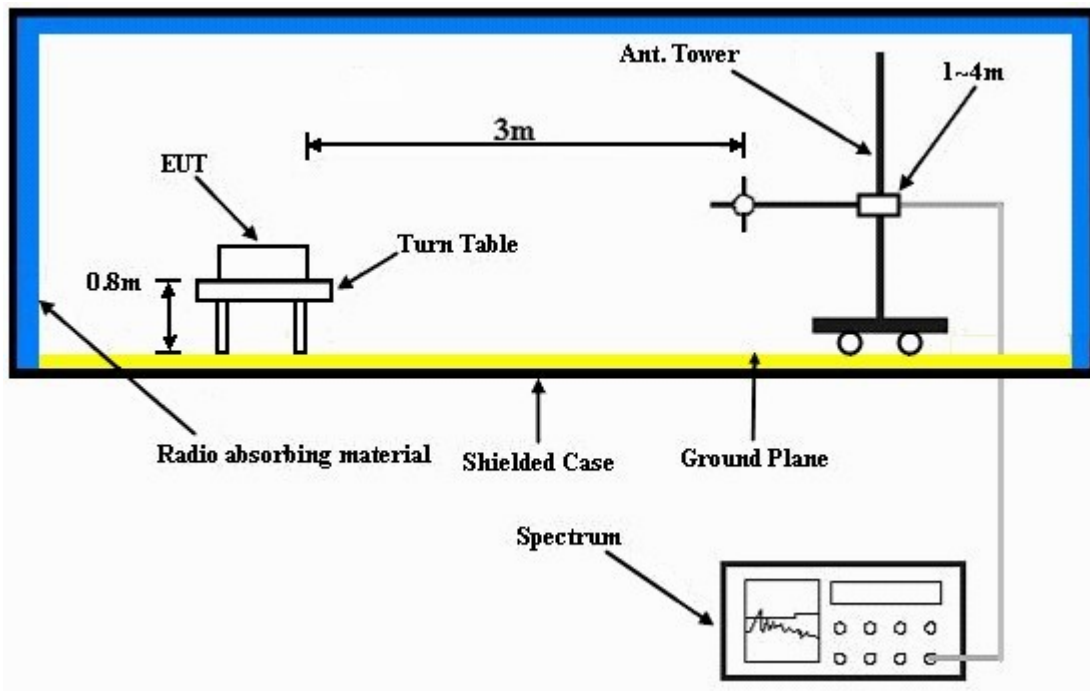

For the actual test configuration, please refer to the attached file (Test Setup Photo).

4.1.6 EUT OPERATING CONDITIONS

- a. Placed the EUT on the testing table.
- b. Prepared a notebook system outside of testing area to act as communication partner.
- c. The communication partners connected with EUT via a RJ45 UTP cable and run a test program (provided by manufacturer) to enable EUT under transmission condition continuously at specific channel frequency.
- d. The communication partner sent data to EUT by command "PING".



A D T

4.1.7 TEST RESULTS

802.11b DSSS MODULATION

EUT TEST CONDITION		MEASUREMENT DETAIL	
CHANNEL	Channel 1	FREQUENCY RANGE	1 ~ 25GHz
INPUT POWER (SYSTEM)	120Vac, 60 Hz	DETECTOR FUNCTION	Peak (PK) Average (AV)
ENVIRONMENTAL CONDITIONS	25deg. C, 65%RH 998hPa	TESTED BY	Brad Wu

ANTENNA POLARITY & TEST DISTANCE: HORIZONTAL AT 3 M								
NO.	FREQ. (MHz)	EMISSION LEVEL (dBuV/m)	LIMIT (dBuV/m)	MARGIN (dB)	ANTENNA HEIGHT (m)	TABLE ANGLE (Degree)	RAW VALUE (dBuV)	CORRECTION FACTOR (dB/m)
1	1000.00	55.34 PK	74.00	-18.66	1.00 H	329	26.20	29.14
2	1000.00	52.57 AV	54.00	-1.43	1.00 H	329	23.43	29.14
3	2390.00	56.05 PK	74.00	-17.95	1.00 H	23	23.61	32.44
4	2390.00	45.64 AV	54.00	-8.36	1.00 H	23	13.20	32.44
5	*2412.00	100.50 PK			1.00 H	23	67.98	32.52
6	*2412.00	95.96 AV			1.00 H	23	63.44	32.52
7	4824.00	52.98 PK	74.00	-21.02	1.00 H	300	14.68	38.30
8	4824.00	47.13 AV	54.00	-6.87	1.00 H	300	8.83	38.30
ANTENNA POLARITY & TEST DISTANCE: VERTICAL AT 3 M								
NO.	FREQ. (MHz)	EMISSION LEVEL (dBuV/m)	LIMIT (dBuV/m)	MARGIN (dB)	ANTENNA HEIGHT (m)	TABLE ANGLE (Degree)	RAW VALUE (dBuV)	CORRECTION FACTOR (dB/m)
1	1000.00	56.20 PK	74.00	-17.80	1.00 V	210	27.06	29.14
2	1000.00	52.92 AV	54.00	-1.08	1.00 V	210	23.78	29.14
3	2390.00	58.97 PK	74.00	-15.03	1.00 V	170	26.53	32.44
4	2390.00	47.82 AV	54.00	-6.18	1.00 V	170	15.38	32.44
5	*2412.00	105.80 PK			1.00 V	170	73.28	32.52
6	*2412.00	101.40 AV			1.00 V	170	68.88	32.52
7	4824.00	55.97 PK	74.00	-18.03	1.00 V	186	17.67	38.30
8	4824.00	52.94 AV	54.00	-1.06	1.00 V	186	14.64	38.30

- REMARKS:**
1. Emission level (dBuV/m) = Raw Value (dBuV) + Correction Factor (dB/m).
 2. Correction Factor (dB/m) = Antenna Factor (dB/m) + Cable Factor (dB).
 3. The other emission levels were very low against the limit.
 4. Margin value = Emission level – Limit value.
 5. “ * “: Fundamental frequency.



A D T

EUT TEST CONDITION		MEASUREMENT DETAIL	
CHANNEL	Channel 6	FREQUENCY RANGE	1 ~ 25GHz
INPUT POWER (SYSTEM)	120Vac, 60 Hz	DETECTOR FUNCTION	Peak (PK) Average (AV)
ENVIRONMENTAL CONDITIONS	25deg. C, 65%RH 998hPa	TESTED BY	Brad Wu

ANTENNA POLARITY & TEST DISTANCE: HORIZONTAL AT 3 M								
NO.	FREQ. (MHz)	EMISSION LEVEL (dBuV/m)	LIMIT (dBuV/m)	MARGIN (dB)	ANTENNA HEIGHT (m)	TABLE ANGLE (Degree)	RAW VALUE (dBuV)	CORRECTION FACTOR (dB/m)
1	1000.00	55.24 PK	74.00	-18.76	1.01 H	330	26.10	29.14
2	1000.00	52.45 AV	54.00	-1.55	1.01 H	330	23.31	29.14
3	*2437.00	100.38 PK			1.02 H	26	67.78	32.60
4	*2437.00	95.84 AV			1.02 H	26	63.24	32.60
5	4874.00	52.84 PK	74.00	-21.16	1.10 H	295	14.34	38.50
6	4874.00	47.09 AV	54.00	-6.91	1.10 H	295	8.59	38.50
ANTENNA POLARITY & TEST DISTANCE: VERTICAL AT 3 M								
NO.	FREQ. (MHz)	EMISSION LEVEL (dBuV/m)	LIMIT (dBuV/m)	MARGIN (dB)	ANTENNA HEIGHT (m)	TABLE ANGLE (Degree)	RAW VALUE (dBuV)	CORRECTION FACTOR (dB/m)
1	1000.00	56.14 PK	74.00	-17.86	1.01 V	211	27.00	29.14
2	1000.00	52.89 AV	54.00	-1.11	1.01 V	211	23.75	29.14
3	*2437.00	105.68 PK			1.01 V	172	73.08	32.60
4	*2437.00	101.19 AV			1.01 V	172	68.59	32.60
5	4874.00	55.80 PK	74.00	-18.20	1.04 V	15	17.30	38.50
6	4874.00	52.96 AV	54.00	-1.04	1.04 V	15	14.46	38.50

- REMARKS:**
1. Emission level (dBuV/m) = Raw Value (dBuV) + Correction Factor (dB/m).
 2. Correction Factor (dB/m) = Antenna Factor (dB/m) + Cable Factor (dB).
 3. The other emission levels were very low against the limit.
 4. Margin value = Emission level – Limit value.
 5. “ * “: Fundamental frequency.



A D T

EUT TEST CONDITION		MEASUREMENT DETAIL	
CHANNEL	Channel 11	FREQUENCY RANGE	1 ~ 25GHz
INPUT POWER (SYSTEM)	120Vac, 60 Hz	DETECTOR FUNCTION	Peak (PK) Average (AV)
ENVIRONMENTAL CONDITIONS	25deg. C, 65%RH 998hPa	TESTED BY	Brad Wu

ANTENNA POLARITY & TEST DISTANCE: HORIZONTAL AT 3 M								
NO.	FREQ. (MHz)	EMISSION LEVEL (dBuV/m)	LIMIT (dBuV/m)	MARGIN (dB)	ANTENNA HEIGHT (m)	TABLE ANGLE (Degree)	RAW VALUE (dBuV)	CORRECTION FACTOR (dB/m)
1	1000.00	55.36 PK	74.00	-18.64	1.02 H	329	26.22	29.14
2	1000.00	52.65 AV	54.00	-1.35	1.02 H	329	23.51	29.14
3	*2462.00	100.61 PK			1.03 H	28	67.93	32.68
4	*2462.00	96.03 AV			1.03 H	28	63.35	32.68
5	2483.50	59.02 PK	74.00	-14.98	1.03 H	28	26.26	32.76
6	2483.50	46.83 AV	54.00	-7.17	1.03 H	28	14.07	32.76
7	4924.00	52.95 PK	74.00	-21.05	1.05 H	304	14.31	38.64
8	4924.00	47.24 AV	54.00	-6.76	1.05 H	304	8.60	38.64
ANTENNA POLARITY & TEST DISTANCE: VERTICAL AT 3 M								
NO.	FREQ. (MHz)	EMISSION LEVEL (dBuV/m)	LIMIT (dBuV/m)	MARGIN (dB)	ANTENNA HEIGHT (m)	TABLE ANGLE (Degree)	RAW VALUE (dBuV)	CORRECTION FACTOR (dB/m)
1	1000.00	56.23 PK	74.00	-17.77	1.02 V	215	27.09	29.14
2	1000.00	52.95 AV	54.00	-1.05	1.02 V	215	23.81	29.14
3	*2462.00	105.92 PK			1.08 V	63	73.24	32.68
4	*2462.00	101.53 AV			1.08 V	63	68.85	32.68
5	2483.50	59.96 PK	74.00	-14.04	1.08 V	63	27.20	32.76
6	2483.50	47.75 AV	54.00	-6.25	1.08 V	63	14.99	32.76
7	4924.00	54.91 PK	74.00	-19.09	1.00 V	18	16.27	38.64
8	4924.00	52.96 AV	54.00	-1.04	1.00 V	18	14.32	38.64

- REMARKS:**
1. Emission level (dBuV/m) = Raw Value (dBuV) + Correction Factor (dB/m).
 2. Correction Factor (dB/m) = Antenna Factor (dB/m) + Cable Factor (dB).
 3. The other emission levels were very low against the limit.
 4. Margin value = Emission level – Limit value.
 5. “ * “: Fundamental frequency.



A D T

802.11g OFDM MODULATION

EUT TEST CONDITION		MEASUREMENT DETAIL	
CHANNEL	Channel 1	FREQUENCY RANGE	1 ~ 25GHz
INPUT POWER (SYSTEM)	120Vac, 60 Hz	DETECTOR FUNCTION	Peak (PK) Average (AV)
ENVIRONMENTAL CONDITIONS	25deg. C, 65%RH 998hPa	TESTED BY	Brad Wu

ANTENNA POLARITY & TEST DISTANCE: HORIZONTAL AT 3 M								
NO.	FREQ. (MHz)	EMISSION LEVEL (dBuV/m)	LIMIT (dBuV/m)	MARGIN (dB)	ANTENNA HEIGHT (m)	TABLE ANGLE (Degree)	RAW VALUE (dBuV)	CORRECTION FACTOR (dB/m)
1	1000.00	62.78 PK	74.00	-11.22	1.00 H	236	33.64	29.14
2	1000.00	52.04 AV	54.00	-1.96	1.00 H	236	22.90	29.14
3	2390.00	59.85 PK	74.00	-14.15	1.00 H	19	27.41	32.44
4	2390.00	47.39 AV	54.00	-6.61	1.00 H	19	14.95	32.44
5	*2412.00	102.50 PK			1.00 H	16	69.98	32.52
6	*2412.00	92.07 AV			1.00 H	16	59.55	32.52
7	4824.00	52.14 PK	74.00	-21.86	1.02 H	48	13.84	38.30
8	4824.00	38.95 AV	54.00	-15.05	1.02 H	48	0.65	38.30
9	#6432.00	56.42 PK	82.50	-26.08	1.01 H	356	14.61	41.81
10	#6432.00	50.90 AV	72.07	-21.17	1.01 H	356	9.09	41.81
ANTENNA POLARITY & TEST DISTANCE: VERTICAL AT 3 M								
NO.	FREQ. (MHz)	EMISSION LEVEL (dBuV/m)	LIMIT (dBuV/m)	MARGIN (dB)	ANTENNA HEIGHT (m)	TABLE ANGLE (Degree)	RAW VALUE (dBuV)	CORRECTION FACTOR (dB/m)
1	1000.00	56.17 PK	74.00	-17.83	1.15 V	341	27.03	29.14
2	1000.00	52.99 AV	54.00	-1.01	1.15 V	341	23.85	29.14
3	2390.00	67.58 PK	74.00	-6.42	1.00 V	191	35.14	32.44
4	2390.00	52.10 AV	54.00	-1.90	1.00 V	191	19.66	32.44
5	*2412.00	110.44 PK			1.00 V	160	77.92	32.52
6	*2412.00	100.60 AV			1.00 V	160	68.08	32.52
7	4824.00	56.63 PK	74.00	-17.37	1.00 V	192	18.33	38.30
8	4824.00	43.98 AV	54.00	-10.02	1.00 V	192	5.68	38.30
9	#6432.00	57.48 PK	90.44	-32.96	1.00 V	45	15.67	41.81
10	#6432.00	51.35 AV	80.60	-29.25	1.00 V	45	9.54	41.81

- REMARKS:**
1. Emission level (dBuV/m) = Raw Value (dBuV) + Correction Factor (dB/m).
 2. Correction Factor (dB/m) = Antenna Factor (dB/m) + Cable Factor (dB).
 3. The other emission levels were very low against the limit.
 4. Margin value = Emission level – Limit value.
 5. “ * “: Fundamental frequency.
 6. “#”:The radiated frequency is out the restricted band.



A D T

EUT TEST CONDITION		MEASUREMENT DETAIL	
CHANNEL	Channel 6	FREQUENCY RANGE	1 ~ 25GHz
INPUT POWER (SYSTEM)	120Vac, 60 Hz	DETECTOR FUNCTION	Peak (PK) Average (AV)
ENVIRONMENTAL CONDITIONS	25deg. C, 65%RH 998hPa	TESTED BY	Brad Wu

ANTENNA POLARITY & TEST DISTANCE: HORIZONTAL AT 3 M								
NO.	FREQ. (MHz)	EMISSION LEVEL (dBuV/m)	LIMIT (dBuV/m)	MARGIN (dB)	ANTENNA HEIGHT (m)	TABLE ANGLE (Degree)	RAW VALUE (dBuV)	CORRECTION FACTOR (dB/m)
1	1000.00	62.41 PK	74.00	-11.59	1.00 H	243	33.27	29.14
2	1000.00	52.33 AV	54.00	-1.67	1.00 H	243	23.19	29.14
3	*2437.00	103.07 PK			1.00 H	58	70.47	32.60
4	*2437.00	92.66 AV			1.00 H	58	60.06	32.60
5	4874.00	52.11 PK	74.00	-21.89	1.00 H	36	13.61	38.50
6	4874.00	39.45 AV	54.00	-14.55	1.00 H	36	0.95	38.50
7	#6498.00	58.36 PK	83.07	-24.71	1.00 H	19	16.36	42.00
8	#6498.00	50.39 AV	72.66	-22.27	1.00 H	19	8.39	42.00
ANTENNA POLARITY & TEST DISTANCE: VERTICAL AT 3 M								
NO.	FREQ. (MHz)	EMISSION LEVEL (dBuV/m)	LIMIT (dBuV/m)	MARGIN (dB)	ANTENNA HEIGHT (m)	TABLE ANGLE (Degree)	RAW VALUE (dBuV)	CORRECTION FACTOR (dB/m)
1	1000.00	56.15 PK	74.00	-17.85	1.15 V	339	27.01	29.14
2	1000.00	52.46 AV	54.00	-1.54	1.15 V	339	23.32	29.14
3	*2437.00	110.47 PK			1.00 V	334	77.87	32.60
4	*2437.00	101.22 AV			1.00 V	334	68.62	32.60
5	4874.00	58.53 PK	74.00	-15.47	1.00 V	17	20.03	38.50
6	4874.00	45.04 AV	54.00	-8.96	1.00 V	17	6.54	38.50
7	#6498.00	60.14 PK	90.47	-30.33	1.00 V	356	18.14	42.00
8	#6498.00	51.64 AV	81.22	-29.58	1.00 V	356	9.64	42.00

- REMARKS:**
1. Emission level (dBuV/m) = Raw Value (dBuV) + Correction Factor (dB/m).
 2. Correction Factor (dB/m) = Antenna Factor (dB/m) + Cable Factor (dB).
 3. The other emission levels were very low against the limit.
 4. Margin value = Emission level – Limit value.
 5. “ * “: Fundamental frequency.
 6. “#“: The radiated frequency is out the restricted band.



A D T

EUT TEST CONDITION		MEASUREMENT DETAIL	
CHANNEL	Channel 11	FREQUENCY RANGE	1 ~ 25GHz
INPUT POWER (SYSTEM)	120Vac, 60 Hz	DETECTOR FUNCTION	Peak (PK) Average (AV)
ENVIRONMENTAL CONDITIONS	25deg. C, 65%RH 998hPa	TESTED BY	Brad Wu

ANTENNA POLARITY & TEST DISTANCE: HORIZONTAL AT 3 M								
NO.	FREQ. (MHz)	EMISSION LEVEL (dBuV/m)	LIMIT (dBuV/m)	MARGIN (dB)	ANTENNA HEIGHT (m)	TABLE ANGLE (Degree)	RAW VALUE (dBuV)	CORRECTION FACTOR (dB/m)
1	1000.00	62.86 PK	74.00	-11.14	1.00 H	241	33.72	29.14
2	1000.00	52.84 AV	54.00	-1.16	1.00 H	241	23.70	29.14
3	*2462.00	102.08 PK			1.00 H	19	69.40	32.68
4	*2462.00	91.87 AV			1.00 H	19	59.19	32.68
5	2483.50	58.38 PK	74.00	-15.62	1.00 H	65	25.62	32.76
6	2483.50	47.95 AV	54.00	-6.05	1.00 H	65	15.19	32.76
7	4924.00	49.16 PK	74.00	-24.84	1.00 H	320	10.52	38.64
8	4924.00	37.26 AV	54.00	-16.74	1.00 H	320	-1.38	38.64
9	#6565.00	57.93 PK	82.08	-24.15	1.02 H	352	15.62	42.31
10	#6565.00	51.26 AV	71.87	-20.61	1.02 H	352	8.95	42.31
ANTENNA POLARITY & TEST DISTANCE: VERTICAL AT 3 M								
NO.	FREQ. (MHz)	EMISSION LEVEL (dBuV/m)	LIMIT (dBuV/m)	MARGIN (dB)	ANTENNA HEIGHT (m)	TABLE ANGLE (Degree)	RAW VALUE (dBuV)	CORRECTION FACTOR (dB/m)
1	1000.00	56.71 PK	74.00	-17.29	1.16 V	342	27.57	29.14
2	1000.00	52.33 AV	54.00	-1.67	1.16 V	342	23.19	29.14
3	*2462.00	110.68 PK			1.25 V	77	78.00	32.68
4	*2462.00	100.85 AV			1.25 V	77	68.17	32.68
5	2483.50	67.61 PK	74.00	-6.39	1.03 V	67	34.85	32.76
6	2483.50	52.46 AV	54.00	-1.54	1.03 V	67	19.70	32.76
7	4924.00	57.42 PK	74.00	-16.58	1.00 V	18	18.78	38.64
8	4924.00	44.45 AV	54.00	-9.55	1.00 V	18	5.81	38.64
9	#6565.00	56.96 PK	90.68	-33.72	1.00 V	355	14.65	42.31
10	#6565.00	51.98 AV	80.85	-28.87	1.00 V	355	9.67	42.31

- REMARKS:**
1. Emission level (dBuV/m) = Raw Value (dBuV) + Correction Factor (dB/m).
 2. Correction Factor (dB/m) = Antenna Factor (dB/m) + Cable Factor (dB).
 3. The other emission levels were very low against the limit.
 4. Margin value = Emission level – Limit value.
 5. “ * “: Fundamental frequency.
 6. “#”:The radiated frequency is out the restricted band.



A D T

DRAFT 802.11n (20MHz) OFDM MODULATION

EUT TEST CONDITION		MEASUREMENT DETAIL	
CHANNEL	Channel 1	FREQUENCY RANGE	1 ~ 25GHz
INPUT POWER (SYSTEM)	120Vac, 60 Hz	DETECTOR FUNCTION	Peak (PK) Average (AV)
ENVIRONMENTAL CONDITIONS	25deg. C, 65%RH 998hPa	TESTED BY	Brad Wu

ANTENNA POLARITY & TEST DISTANCE: HORIZONTAL AT 3 M								
NO.	FREQ. (MHz)	EMISSION LEVEL (dBuV/m)	LIMIT (dBuV/m)	MARGIN (dB)	ANTENNA HEIGHT (m)	TABLE ANGLE (Degree)	RAW VALUE (dBuV)	CORRECTION FACTOR (dB/m)
1	1000.00	55.04 PK	74.00	-18.96	1.05 H	303	25.90	29.14
2	1000.00	52.08 AV	54.00	-1.92	1.05 H	303	22.94	29.14
3	2390.00	60.28 PK	74.00	-13.72	1.00 H	335	27.84	32.44
4	2390.00	47.34 AV	54.00	-6.66	1.00 H	335	14.90	32.44
5	*2412.00	101.93 PK			1.00 H	335	69.41	32.52
6	*2412.00	91.81 AV			1.00 H	335	59.29	32.52
7	4824.00	50.22 PK	74.00	-23.78	1.12 H	6	11.92	38.30
8	4824.00	37.02 AV	54.00	-16.98	1.12 H	6	-1.28	38.30
ANTENNA POLARITY & TEST DISTANCE: VERTICAL AT 3 M								
NO.	FREQ. (MHz)	EMISSION LEVEL (dBuV/m)	LIMIT (dBuV/m)	MARGIN (dB)	ANTENNA HEIGHT (m)	TABLE ANGLE (Degree)	RAW VALUE (dBuV)	CORRECTION FACTOR (dB/m)
1	1000.00	56.15 PK	74.00	-17.85	1.04 V	202	27.01	29.14
2	1000.00	52.63 AV	54.00	-1.37	1.04 V	202	23.49	29.14
3	2390.00	69.08 PK	74.00	-4.92	1.00 V	347	36.64	32.44
4	2390.00	52.14 AV	54.00	-1.86	1.00 V	347	19.70	32.44
5	*2412.00	110.79 PK			1.00 V	341	78.27	32.52
6	*2412.00	100.40 AV			1.00 V	341	67.88	32.52
7	4824.00	55.32 PK	74.00	-18.68	1.73 V	2	17.02	38.30
8	4824.00	40.34 AV	54.00	-13.66	1.73 V	2	2.04	38.30

- REMARKS:**
1. Emission level (dBuV/m) = Raw Value (dBuV) + Correction Factor (dB/m).
 2. Correction Factor (dB/m) = Antenna Factor (dB/m) + Cable Factor (dB).
 3. The other emission levels were very low against the limit.
 4. Margin value = Emission level – Limit value.
 5. “ * “: Fundamental frequency.



A D T

EUT TEST CONDITION		MEASUREMENT DETAIL	
CHANNEL	Channel 6	FREQUENCY RANGE	1 ~ 25GHz
INPUT POWER (SYSTEM)	120Vac, 60 Hz	DETECTOR FUNCTION	Peak (PK) Average (AV)
ENVIRONMENTAL CONDITIONS	25deg. C, 65%RH 998hPa	TESTED BY	Brad Wu

ANTENNA POLARITY & TEST DISTANCE: HORIZONTAL AT 3 M								
NO.	FREQ. (MHz)	EMISSION LEVEL (dBuV/m)	LIMIT (dBuV/m)	MARGIN (dB)	ANTENNA HEIGHT (m)	TABLE ANGLE (Degree)	RAW VALUE (dBuV)	CORRECTION FACTOR (dB/m)
1	1000.00	54.86 PK	74.00	-19.14	1.02 H	306	25.72	29.14
2	1000.00	51.91 AV	54.00	-2.09	1.02 H	306	22.77	29.14
3	*2437.00	101.62 PK			1.02 H	336	69.02	32.60
4	*2437.00	91.53 AV			1.02 H	336	58.93	32.60
5	4874.00	50.46 PK	74.00	-23.54	1.15 H	18	11.96	38.50
6	4874.00	37.28 AV	54.00	-16.72	1.15 H	18	-1.22	38.50
ANTENNA POLARITY & TEST DISTANCE: VERTICAL AT 3 M								
NO.	FREQ. (MHz)	EMISSION LEVEL (dBuV/m)	LIMIT (dBuV/m)	MARGIN (dB)	ANTENNA HEIGHT (m)	TABLE ANGLE (Degree)	RAW VALUE (dBuV)	CORRECTION FACTOR (dB/m)
1	1000.00	56.03 PK	74.00	-17.97	1.02 V	206	26.89	29.14
2	1000.00	52.48 AV	54.00	-1.52	1.02 V	206	23.34	29.14
3	*2437.00	110.45 PK			1.00 V	338	77.85	32.60
4	*2437.00	100.18 AV			1.00 V	338	67.58	32.60
5	4874.00	55.62 PK	74.00	-18.38	1.62 V	15	17.12	38.50
6	4874.00	40.68 AV	54.00	-13.32	1.62 V	15	2.18	38.50

- REMARKS:**
1. Emission level (dBuV/m) = Raw Value (dBuV) + Correction Factor (dB/m).
 2. Correction Factor (dB/m) = Antenna Factor (dB/m) + Cable Factor (dB).
 3. The other emission levels were very low against the limit.
 4. Margin value = Emission level – Limit value.
 5. “ * “: Fundamental frequency.



A D T

EUT TEST CONDITION		MEASUREMENT DETAIL	
CHANNEL	Channel 11	FREQUENCY RANGE	1 ~ 25GHz
INPUT POWER (SYSTEM)	120Vac, 60 Hz	DETECTOR FUNCTION	Peak (PK) Average (AV)
ENVIRONMENTAL CONDITIONS	25deg. C, 65%RH 998hPa	TESTED BY	Brad Wu

ANTENNA POLARITY & TEST DISTANCE: HORIZONTAL AT 3 M								
NO.	FREQ. (MHz)	EMISSION LEVEL (dBuV/m)	LIMIT (dBuV/m)	MARGIN (dB)	ANTENNA HEIGHT (m)	TABLE ANGLE (Degree)	RAW VALUE (dBuV)	CORRECTION FACTOR (dB/m)
1	1000.00	54.92 PK	74.00	-19.08	1.02 H	309	25.78	29.14
2	1000.00	51.84 AV	54.00	-2.16	1.02 H	309	22.70	29.14
3	*2462.00	101.98 PK			1.02 H	338	69.30	32.68
4	*2462.00	91.92 AV			1.02 H	338	59.24	32.68
5	2483.50	60.11 PK	74.00	-13.89	1.02 H	338	27.35	32.76
6	2483.50	47.19 AV	54.00	-6.81	1.02 H	338	14.43	32.76
7	4924.00	50.36 PK	74.00	-23.64	1.13 H	242	11.72	38.64
8	4924.00	37.25 AV	54.00	-16.75	1.13 H	242	-1.39	38.64
ANTENNA POLARITY & TEST DISTANCE: VERTICAL AT 3 M								
NO.	FREQ. (MHz)	EMISSION LEVEL (dBuV/m)	LIMIT (dBuV/m)	MARGIN (dB)	ANTENNA HEIGHT (m)	TABLE ANGLE (Degree)	RAW VALUE (dBuV)	CORRECTION FACTOR (dB/m)
1	1000.00	56.24 PK	74.00	-17.76	1.03 V	209	27.10	29.14
2	1000.00	52.69 AV	54.00	-1.31	1.03 V	209	23.55	29.14
3	*2462.00	110.99 PK			1.14 V	312	78.31	32.68
4	*2462.00	100.65 AV			1.14 V	312	67.97	32.68
5	2483.50	65.78 PK	74.00	-8.22	1.32 V	293	33.02	32.76
6	2483.50	52.33 AV	54.00	-1.67	1.32 V	293	19.57	32.76
7	4924.00	55.84 PK	74.00	-18.16	1.19 V	308	17.20	38.64
8	4924.00	40.92 AV	54.00	-13.08	1.19 V	308	2.28	38.64

- REMARKS:**
1. Emission level (dBuV/m) = Raw Value (dBuV) + Correction Factor (dB/m).
 2. Correction Factor (dB/m) = Antenna Factor (dB/m) + Cable Factor (dB).
 3. The other emission levels were very low against the limit.
 4. Margin value = Emission level – Limit value.
 5. “ * “: Fundamental frequency.



A D T

DRAFT 802.11n (40MHz) OFDM MODULATION

EUT TEST CONDITION		MEASUREMENT DETAIL	
CHANNEL	Channel 1	FREQUENCY RANGE	1 ~ 25GHz
INPUT POWER (SYSTEM)	120Vac, 60 Hz	DETECTOR FUNCTION	Peak (PK) Average (AV)
ENVIRONMENTAL CONDITIONS	25deg. C, 65%RH 998hPa	TESTED BY	Brad Wu

ANTENNA POLARITY & TEST DISTANCE: HORIZONTAL AT 3 M								
NO.	FREQ. (MHz)	EMISSION LEVEL (dBuV/m)	LIMIT (dBuV/m)	MARGIN (dB)	ANTENNA HEIGHT (m)	TABLE ANGLE (Degree)	RAW VALUE (dBuV)	CORRECTION FACTOR (dB/m)
1	1000.00	55.12 PK	74.00	-18.88	1.03 H	296	25.98	29.14
2	1000.00	52.18 AV	54.00	-1.82	1.03 H	296	23.04	29.14
3	2390.00	60.25 PK	74.00	-13.75	1.18 H	224	27.81	32.44
4	2390.00	47.71 AV	54.00	-6.29	1.18 H	224	15.27	32.44
5	*2422.00	98.13 PK			1.00 H	187	65.58	32.55
6	*2422.00	87.54 AV			1.00 H	187	54.99	32.55
7	4844.00	50.62 PK	74.00	-23.38	1.06 H	218	12.24	38.38
8	4844.00	37.02 AV	54.00	-16.98	1.06 H	218	-1.36	38.38
ANTENNA POLARITY & TEST DISTANCE: VERTICAL AT 3 M								
NO.	FREQ. (MHz)	EMISSION LEVEL (dBuV/m)	LIMIT (dBuV/m)	MARGIN (dB)	ANTENNA HEIGHT (m)	TABLE ANGLE (Degree)	RAW VALUE (dBuV)	CORRECTION FACTOR (dB/m)
1	1000.00	56.02 PK	74.00	-17.98	1.02 V	196	26.88	29.14
2	1000.00	52.55 AV	54.00	-1.45	1.02 V	196	23.41	29.14
3	2390.00	66.86 PK	74.00	-7.14	1.39 V	269	34.42	32.44
4	2390.00	52.57 AV	54.00	-1.43	1.39 V	269	20.13	32.44
5	*2422.00	107.76 PK			1.11 V	73	75.21	32.55
6	*2422.00	97.45 AV			1.11 V	73	64.90	32.55
7	4844.00	50.92 PK	74.00	-23.08	1.04 V	211	12.54	38.38
8	4844.00	37.34 AV	54.00	-16.66	1.04 V	211	-1.04	38.38

- REMARKS:**
1. Emission level (dBuV/m) = Raw Value (dBuV) + Correction Factor (dB/m).
 2. Correction Factor (dB/m) = Antenna Factor (dB/m) + Cable Factor (dB).
 3. The other emission levels were very low against the limit.
 4. Margin value = Emission level – Limit value.
 5. “ * “: Fundamental frequency.



A D T

EUT TEST CONDITION		MEASUREMENT DETAIL	
CHANNEL	Channel 4	FREQUENCY RANGE	1 ~ 25GHz
INPUT POWER (SYSTEM)	120Vac, 60 Hz	DETECTOR FUNCTION	Peak (PK) Average (AV)
ENVIRONMENTAL CONDITIONS	25deg. C, 65%RH 998hPa	TESTED BY	Brad Wu

ANTENNA POLARITY & TEST DISTANCE: HORIZONTAL AT 3 M								
NO.	FREQ. (MHz)	EMISSION LEVEL (dBuV/m)	LIMIT (dBuV/m)	MARGIN (dB)	ANTENNA HEIGHT (m)	TABLE ANGLE (Degree)	RAW VALUE (dBuV)	CORRECTION FACTOR (dB/m)
1	1000.00	55.03 PK	74.00	-18.97	1.04 H	295	25.89	29.14
2	1000.00	52.06 AV	54.00	-1.94	1.04 H	295	22.92	29.14
3	*2437.00	98.42 PK			1.01 H	192	65.82	32.60
4	*2437.00	87.72 AV			1.01 H	192	55.12	32.60
5	4874.00	50.85 PK	74.00	-23.15	1.01 H	223	12.35	38.50
6	4874.00	37.26 AV	54.00	-16.74	1.01 H	223	-1.24	38.50
ANTENNA POLARITY & TEST DISTANCE: VERTICAL AT 3 M								
NO.	FREQ. (MHz)	EMISSION LEVEL (dBuV/m)	LIMIT (dBuV/m)	MARGIN (dB)	ANTENNA HEIGHT (m)	TABLE ANGLE (Degree)	RAW VALUE (dBuV)	CORRECTION FACTOR (dB/m)
1	1000.00	55.94 PK	74.00	-18.06	1.05 V	202	26.80	29.14
2	1000.00	52.35 AV	54.00	-1.65	1.05 V	202	23.21	29.14
3	*2437.00	107.96 PK			1.12 V	75	75.36	32.60
4	*2437.00	97.56 AV			1.12 V	75	64.96	32.60
5	4874.00	51.16 PK	74.00	-22.84	1.06 V	208	12.66	38.50
6	4874.00	37.58 AV	54.00	-16.42	1.06 V	208	-0.92	38.50

- REMARKS:**
1. Emission level (dBuV/m) = Raw Value (dBuV) + Correction Factor (dB/m).
 2. Correction Factor (dB/m) = Antenna Factor (dB/m) + Cable Factor (dB).
 3. The other emission levels were very low against the limit.
 4. Margin value = Emission level – Limit value.
 5. “ * “: Fundamental frequency.



A D T

EUT TEST CONDITION		MEASUREMENT DETAIL	
CHANNEL	Channel 7	FREQUENCY RANGE	1 ~ 25GHz
INPUT POWER (SYSTEM)	120Vac, 60 Hz	DETECTOR FUNCTION	Peak (PK) Average (AV)
ENVIRONMENTAL CONDITIONS	25deg. C, 65%RH 998hPa	TESTED BY	Brad Wu

ANTENNA POLARITY & TEST DISTANCE: HORIZONTAL AT 3 M								
NO.	FREQ. (MHz)	EMISSION LEVEL (dBuV/m)	LIMIT (dBuV/m)	MARGIN (dB)	ANTENNA HEIGHT (m)	TABLE ANGLE (Degree)	RAW VALUE (dBuV)	CORRECTION FACTOR (dB/m)
1	1000.00	54.85 PK	74.00	-19.15	1.01 H	302	25.71	29.14
2	1000.00	51.93 AV	54.00	-2.07	1.01 H	302	22.79	29.14
3	*2452.00	98.01 PK			1.00 H	196	65.36	32.65
4	*2452.00	87.35 AV			1.00 H	196	54.70	32.65
5	2483.50	60.02 PK	74.00	-13.98	1.00 H	196	27.26	32.76
6	2483.50	47.48 AV	54.00	-6.52	1.00 H	196	14.72	32.76
7	4904.00	50.51 PK	74.00	-23.49	1.01 H	225	11.90	38.61
8	4904.00	36.88 AV	54.00	-17.12	1.01 H	225	-1.73	38.61
ANTENNA POLARITY & TEST DISTANCE: VERTICAL AT 3 M								
NO.	FREQ. (MHz)	EMISSION LEVEL (dBuV/m)	LIMIT (dBuV/m)	MARGIN (dB)	ANTENNA HEIGHT (m)	TABLE ANGLE (Degree)	RAW VALUE (dBuV)	CORRECTION FACTOR (dB/m)
1	1000.00	55.82 PK	74.00	-18.18	1.02 V	209	26.68	29.14
2	1000.00	52.21 AV	54.00	-1.79	1.02 V	209	23.07	29.14
3	*2452.00	107.56 PK			1.11 V	82	74.91	32.65
4	*2452.00	97.34 AV			1.11 V	82	64.69	32.65
5	2483.50	64.68 PK	74.00	-9.32	1.10 V	73	31.92	32.76
6	2483.50	51.83 AV	54.00	-2.17	1.10 V	73	19.07	32.76
7	4904.00	51.25 PK	74.00	-22.75	1.03 V	221	12.64	38.61
8	4904.00	37.69 AV	54.00	-16.31	1.03 V	221	-0.92	38.61

- REMARKS:**
1. Emission level (dBuV/m) = Raw Value (dBuV) + Correction Factor (dB/m).
 2. Correction Factor (dB/m) = Antenna Factor (dB/m) + Cable Factor (dB).
 3. The other emission levels were very low against the limit.
 4. Margin value = Emission level – Limit value.
 5. “ * “: Fundamental frequency.



A D T

BELOW 1GHz WORST-CASE DATA : 802.11g OFDM MODULATION

EUT TEST CONDITION		MEASUREMENT DETAIL	
CHANNEL	Channel 6	FREQUENCY RANGE	Below 1000MHz
INPUT POWER (SYSTEM)	120Vac, 60 Hz	DETECTOR FUNCTION	Quasi-Peak
ENVIRONMENTAL CONDITIONS	25deg. C, 65%RH 1023hPa	TESTED BY	Brad Wu
TEST MODE	A		

ANTENNA POLARITY & TEST DISTANCE: HORIZONTAL AT 3 M								
NO.	FREQ. (MHz)	EMISSION LEVEL (dBuV/m)	LIMIT (dBuV/m)	MARGIN (dB)	ANTENNA HEIGHT (m)	TABLE ANGLE (Degree)	RAW VALUE (dBuV)	CORRECTION FACTOR (dB/m)
1	132.95	35.71 QP	43.50	-7.79	2.00 H	79	23.36	12.36
2	249.60	41.97 QP	46.00	-4.03	1.25 H	253	28.17	13.80
3	399.31	37.03 QP	46.00	-8.97	1.00 H	295	19.01	18.02
4	624.85	39.24 QP	46.00	-6.76	1.00 H	187	16.15	23.09
5	750.06	44.65 QP	46.00	-1.35	1.00 H	192	19.16	25.50
6	875.67	43.30 QP	46.00	-2.70	1.50 H	334	15.87	27.43
ANTENNA POLARITY & TEST DISTANCE: VERTICAL AT 3 M								
NO.	FREQ. (MHz)	EMISSION LEVEL (dBuV/m)	LIMIT (dBuV/m)	MARGIN (dB)	ANTENNA HEIGHT (m)	TABLE ANGLE (Degree)	RAW VALUE (dBuV)	CORRECTION FACTOR (dB/m)
1	41.57	38.21 QP	40.00	-1.79	1.00 V	289	23.34	14.87
2	132.95	41.64 QP	43.50	-1.86	1.00 V	10	29.29	12.36
3	249.60	44.83 QP	46.00	-1.17	1.25 V	349	31.03	13.80
4	667.63	42.22 QP	46.00	-3.78	1.25 V	10	17.99	24.23
5	751.23	41.96 QP	46.00	-4.04	1.50 V	40	16.45	25.51
6	799.84	41.54 QP	46.00	-4.46	1.50 V	1	15.52	26.02
7	875.67	42.99 QP	46.00	-3.01	1.00 V	274	15.56	27.43
8	933.99	42.13 QP	46.00	-3.87	1.00 V	154	13.78	28.35

- REMARKS:**
1. Emission level (dBuV/m) = Raw Value (dBuV) + Correction Factor (dB/m).
 2. Correction Factor (dB/m) = Antenna Factor (dB/m) + Cable Factor (dB).
 3. The other emission levels were very low against the limit.
 4. Margin value = Emission level – Limit value.



A D T

EUT TEST CONDITION		MEASUREMENT DETAIL	
CHANNEL	Channel 6	FREQUENCY RANGE	Below 1000MHz
INPUT POWER (SYSTEM)	120Vac, 60 Hz	DETECTOR FUNCTION	Quasi-Peak
ENVIRONMENTAL CONDITIONS	25deg. C, 65%RH 1023hPa	TESTED BY	Brad Wu
TEST MODE	B		

ANTENNA POLARITY & TEST DISTANCE: HORIZONTAL AT 3 M								
NO.	FREQ. (MHz)	EMISSION LEVEL (dBuV/m)	LIMIT (dBuV/m)	MARGIN (dB)	ANTENNA HEIGHT (m)	TABLE ANGLE (Degree)	RAW VALUE (dBuV)	CORRECTION FACTOR (dB/m)
1	132.95	40.98 QP	43.50	-2.52	2.00 H	184	28.62	12.36
2	249.60	44.02 QP	46.00	-1.98	1.00 H	157	30.22	13.80
3	500.42	44.62 QP	46.00	-1.38	2.00 H	163	24.18	20.44
4	667.63	40.70 QP	46.00	-5.30	1.00 H	211	16.46	24.23
5	799.84	41.32 QP	46.00	-4.68	1.50 H	241	15.30	26.02
6	933.99	41.18 QP	46.00	-4.82	1.50 H	256	12.83	28.35
ANTENNA POLARITY & TEST DISTANCE: VERTICAL AT 3 M								
NO.	FREQ. (MHz)	EMISSION LEVEL (dBuV/m)	LIMIT (dBuV/m)	MARGIN (dB)	ANTENNA HEIGHT (m)	TABLE ANGLE (Degree)	RAW VALUE (dBuV)	CORRECTION FACTOR (dB/m)
1	132.95	36.53 QP	43.50	-6.97	1.00 V	286	24.18	12.36
2	399.31	41.60 QP	46.00	-4.40	1.50 V	307	23.58	18.02
3	533.47	38.02 QP	46.00	-7.98	1.00 V	175	16.89	21.13
4	667.63	40.84 QP	46.00	-5.16	1.00 V	10	16.60	24.23
5	799.84	42.88 QP	46.00	-3.12	1.50 V	172	16.86	26.02
6	933.99	42.50 QP	46.00	-3.50	1.00 V	154	14.15	28.35

- REMARKS:**
1. Emission level (dBuV/m) = Raw Value (dBuV) + Correction Factor (dB/m).
 2. Correction Factor (dB/m) = Antenna Factor (dB/m) + Cable Factor (dB).
 3. The other emission levels were very low against the limit.
 4. Margin value = Emission level – Limit value.



A D T

4.2 CONDUCTED EMISSION MEASUREMENT

4.2.1 LIMITS OF CONDUCTED EMISSION MEASUREMENT

FREQUENCY OF EMISSION (MHz)	CONDUCTED LIMIT (dB μ V)	
	Quasi-peak	Average
0.15 ~ 0.5	66 to 56	56 to 46
0.5 ~ 5	56	46
5 ~ 30	60	50

- NOTE:** 1. The lower limit shall apply at the transition frequencies.
 2. The limit decreases in line with the logarithm of the frequency in the range of 0.15 to 0.50MHz.
 3. All emanations from a class A/B digital device or system, including any network of conductors and apparatus connected thereto, shall not exceed the level of field strengths specified above.

4.2.2 TEST INSTRUMENTS

DESCRIPTION & MANUFACTURER	MODEL NO.	SERIAL NO.	DATE OF CALIBRATION	DUE DATE OF CALIBRATION
Test Receiver ROHDE & SCHWARZ	ESCS30	100288	Sep. 22, 2008	Sep. 21, 2009
RF signal cable Woken	5D-FB	Cable-HYCO2-01	Dec. 31, 2008	Dec. 30, 2009
LISN ROHDE & SCHWARZ	ESH2-Z5	100100	Dec. 29, 2008	Dec. 28, 2009
LISN ROHDE & SCHWARZ	ESH3-Z5	100311	Jul. 30, 2008	Jul. 29, 2009
Software ADT	ADT_Cond_ V7.3.6	NA	NA	NA

- NOTE:** 1. The calibration interval of the above test instruments is 12 months and the calibrations are traceable to NML/ROC and NIST/USA.
 2. The test was performed in HwaYa Shielded Room 2.
 3. The VCCI Site Registration No. is C-2047.



A D T

4.2.3 TEST PROCEDURES

- a. The EUT was placed 0.4 meters from the conducting wall of the shielded room with EUT being connected to the power mains through a line impedance stabilization network (LISN). Other support units were connected to the power mains through another LISN. The two LISNs provide 50 ohm/ 50uH of coupling impedance for the measuring instrument.
- b. Both lines of the power mains connected to the EUT were checked for maximum conducted interference.
- c. The frequency range from 150kHz to 30MHz was searched. Emission levels under (Limit - 20dB) was not recorded.

NOTE: All modes of operation were investigated and the worst-case emissions are reported.

4.2.4 DEVIATION FROM TEST STANDARD

No deviation.

4.2.5 TEST SETUP

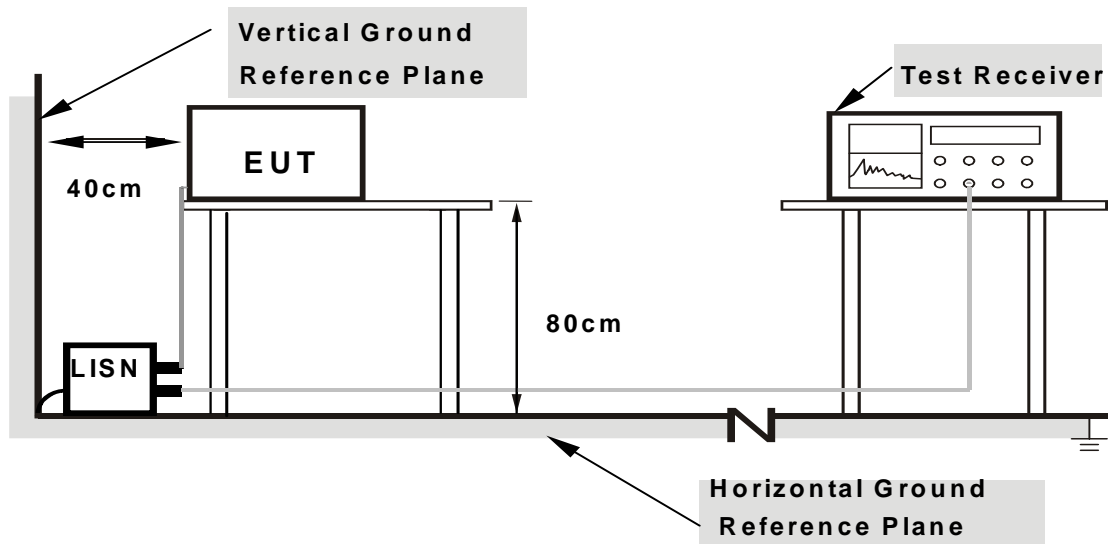

- Note:**
1. Support units were connected to second LISN.
 2. Both of LISNs (AMN) are 80 cm from EUT and at least 80 from other units and other metal planes

For the actual test configuration, please refer to the attached file (Test Setup Photo).

4.2.6 EUT OPERATING CONDITIONS

Same as 4.1.6.

4.2.7 TEST RESULTS

CONDUCTED WORST-CASE DATA : 802.11g OFDM MODULATION

EUT TEST CONDITION		MEASUREMENT DETAIL	
CHANNEL	Channel 6	PHASE	Line 1
MODULATION TYPE	BPSK	INPUT POWER	120Vac, 60Hz
TRANSFER RATE	6.0Mbps	6dB BANDWIDTH	9kHz
ENVIRONMENTAL CONDITIONS	23deg. C, 68%RH, 1021hPa	TESTED BY	Antony Lee
TEST MODE	A		

No	Freq. [MHz]	Corr. Factor (dB)	Reading Value [dB (uV)]		Emission Level [dB (uV)]		Limit [dB (uV)]		Margin (dB)	
			Q.P.	AV.	Q.P.	AV.	Q.P.	AV.	Q.P.	AV.
			1	0.189	0.13	28.09	-	28.22	-	64.08
2	0.252	0.13	29.00	-	29.13	-	61.71	51.71	-32.57	-
3	1.516	0.18	24.64	-	24.82	-	56.00	46.00	-31.18	-
4	4.164	0.28	34.82	-	35.10	-	56.00	46.00	-20.90	-
5	4.551	0.29	33.47	-	33.76	-	56.00	46.00	-22.24	-
6	12.998	0.50	28.65	-	29.15	-	60.00	50.00	-30.85	-

- REMARKS:**
1. Q.P. and AV. are abbreviations of quasi-peak and average individually.
 2. "-": The Quasi-peak reading value also meets average limit and measurement with the average detector is unnecessary.
 3. The emission levels of other frequencies were very low against the limit.
 4. Margin value = Emission level - Limit value
 5. Correction factor = Insertion loss + Cable loss
 6. Emission Level = Correction Factor + Reading Value.

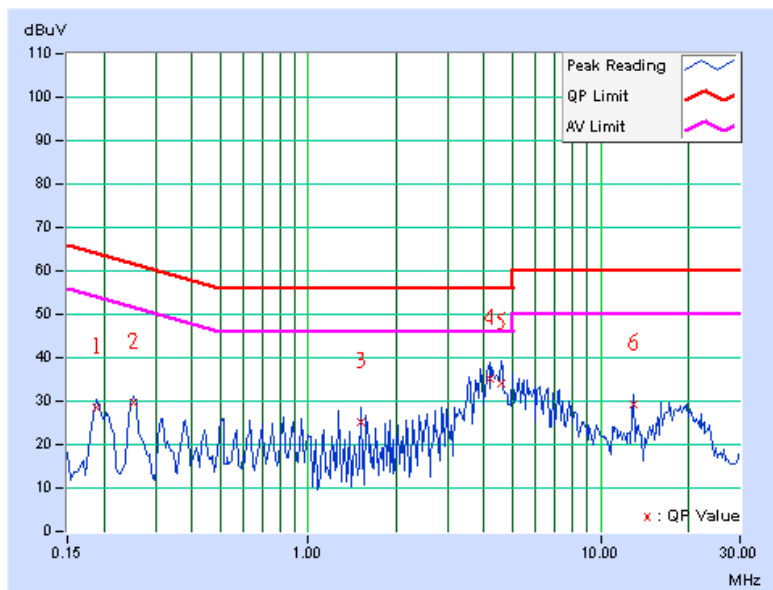

EUT TEST CONDITION		MEASUREMENT DETAIL	
CHANNEL	Channel 6	PHASE	Line 2
MODULATION TYPE	BPSK	INPUT POWER	120Vac, 60Hz
TRANSFER RATE	6.0Mbps	6dB BANDWIDTH	9kHz
ENVIRONMENTAL CONDITIONS	23deg. C, 68%RH, 1021hPa	TESTED BY	Antony Lee
TEST MODE	A		

No	Freq. [MHz]	Corr. Factor (dB)	Reading Value		Emission Level		Limit		Margin	
			[dB (uV)]		[dB (uV)]		[dB (uV)]		(dB)	
			Q.P.	AV.	Q.P.	AV.	Q.P.	AV.	Q.P.	AV.
1	0.189	0.13	30.47	-	30.60	-	64.08	54.08	-33.48	-
2	0.252	0.14	30.65	-	30.79	-	61.71	51.71	-30.92	-
3	0.505	0.15	25.57	-	25.72	-	56.00	46.00	-30.28	-
4	1.137	0.17	25.70	-	25.87	-	56.00	46.00	-30.13	-
5	4.289	0.31	27.27	-	27.58	-	56.00	46.00	-28.42	-
6	16.711	0.72	22.47	-	23.19	-	60.00	50.00	-36.81	-

- REMARKS:**
1. Q.P. and AV. are abbreviations of quasi-peak and average individually.
 2. "-": The Quasi-peak reading value also meets average limit and measurement with the average detector is unnecessary.
 3. The emission levels of other frequencies were very low against the limit.
 4. Margin value = Emission level - Limit value
 5. Correction factor = Insertion loss + Cable loss
 6. Emission Level = Correction Factor + Reading Value.

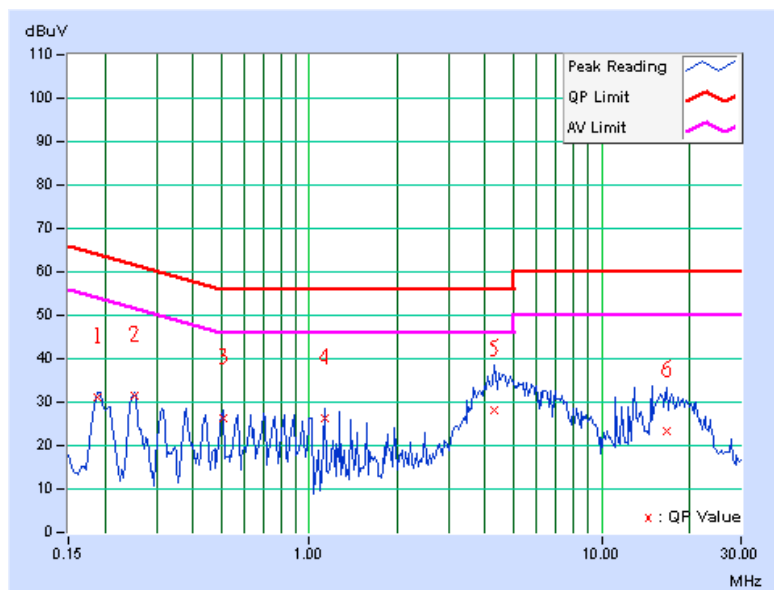

EUT TEST CONDITION		MEASUREMENT DETAIL	
CHANNEL	Channel 6	PHASE	Line 1
MODULATION TYPE	BPSK	INPUT POWER	120Vac, 60Hz
TRANSFER RATE	6.0Mbps	6dB BANDWIDTH	9kHz
ENVIRONMENTAL CONDITIONS	25deg. C, 75%RH, 1021hPa	TESTED BY	Lori Chiu
TEST MODE	B		

No	Freq. [MHz]	Corr. Factor (dB)	Reading Value		Emission Level		Limit		Margin	
			[dB (uV)]		[dB (uV)]		[dB (uV)]		(dB)	
			Q.P.	AV.	Q.P.	AV.	Q.P.	AV.	Q.P.	AV.
1	0.259	0.13	22.20	-	22.33	-	61.45	51.45	-39.12	-
2	0.443	0.14	17.20	-	17.34	-	57.01	47.01	-39.66	-
3	0.896	0.16	20.36	-	20.52	-	56.00	46.00	-35.48	-
4	1.207	0.17	16.70	-	16.87	-	56.00	46.00	-39.13	-
5	2.148	0.20	5.72	-	5.92	-	56.00	46.00	-50.08	-
6	14.152	0.53	32.20	-	32.73	-	60.00	50.00	-27.27	-

- REMARKS:**
1. Q.P. and AV. are abbreviations of quasi-peak and average individually.
 2. "-": The Quasi-peak reading value also meets average limit and measurement with the average detector is unnecessary.
 3. The emission levels of other frequencies were very low against the limit.
 4. Margin value = Emission level - Limit value
 5. Correction factor = Insertion loss + Cable loss
 6. Emission Level = Correction Factor + Reading Value.

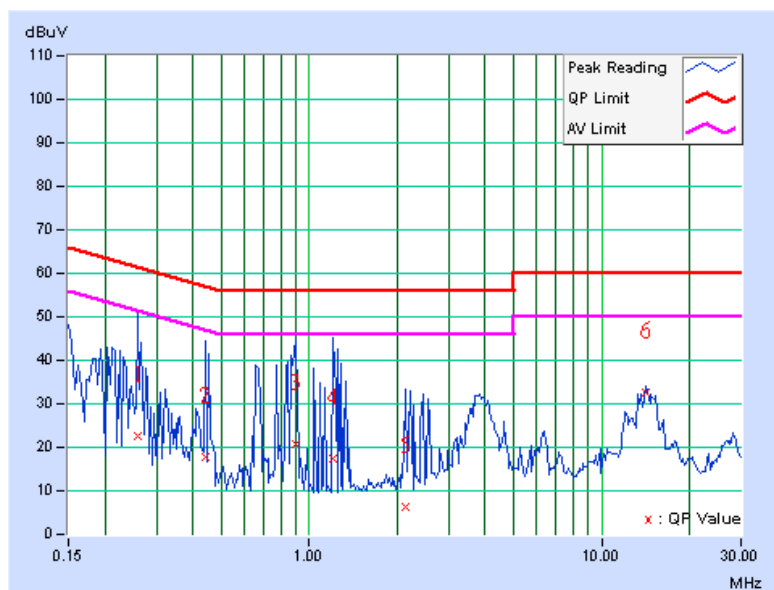

EUT TEST CONDITION		MEASUREMENT DETAIL	
CHANNEL	Channel 6	PHASE	Line 2
MODULATION TYPE	BPSK	INPUT POWER	120Vac, 60Hz
TRANSFER RATE	6.0Mbps	6dB BANDWIDTH	9kHz
ENVIRONMENTAL CONDITIONS	25deg. C, 75%RH, 1021hPa	TESTED BY	Lori Chiu
TEST MODE	B		

No	Freq. [MHz]	Corr. Factor (dB)	Reading Value		Emission Level		Limit		Margin	
			[dB (uV)]		[dB (uV)]		[dB (uV)]		(dB)	
			Q.P.	AV.	Q.P.	AV.	Q.P.	AV.	Q.P.	AV.
1	0.166	0.13	30.10	-	30.23	-	65.18	55.18	-34.95	-
2	0.201	0.13	32.38	-	32.51	-	63.58	53.58	-31.07	-
3	0.396	0.15	21.50	-	21.65	-	57.93	47.93	-36.29	-
4	0.970	0.17	15.16	-	15.33	-	56.00	46.00	-40.67	-
5	3.070	0.25	16.14	-	16.39	-	56.00	46.00	-39.61	-
6	14.211	0.64	32.05	-	32.69	-	60.00	50.00	-27.31	-

- REMARKS:**
1. Q.P. and AV. are abbreviations of quasi-peak and average individually.
 2. "-": The Quasi-peak reading value also meets average limit and measurement with the average detector is unnecessary.
 3. The emission levels of other frequencies were very low against the limit.
 4. Margin value = Emission level - Limit value
 5. Correction factor = Insertion loss + Cable loss
 6. Emission Level = Correction Factor + Reading Value.

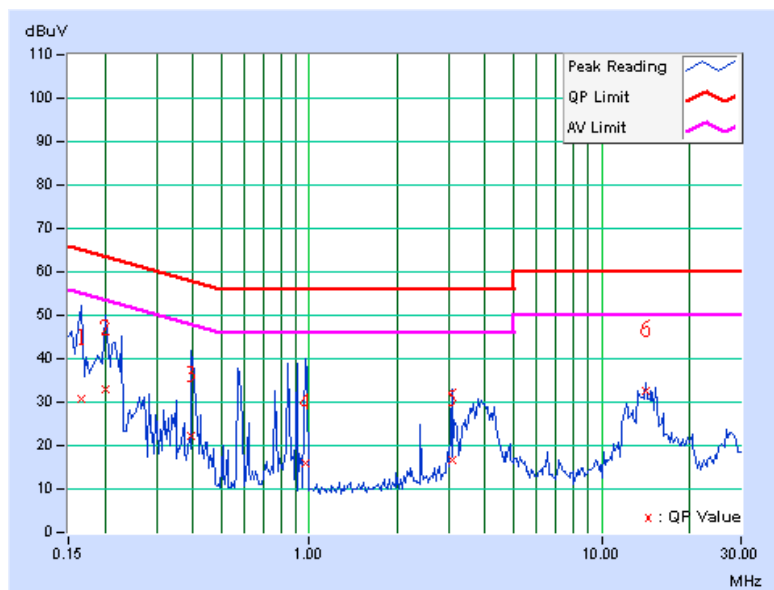



A D T

4.3 6dB BANDWIDTH MEASUREMENT

4.3.1 LIMITS OF 6dB BANDWIDTH MEASUREMENT

The minimum of 6dB Bandwidth Measurement is 0.5 MHz.

4.3.2 TEST INSTRUMENTS

DESCRIPTION & MANUFACTURER	MODEL NO.	SERIAL NO.	DATE OF CALIBRATION	DUE DATE OF CALIBRATION
R&S SPECTRUM ANALYZER	FSP40	100041	Apr. 22, 2008	Apr. 21, 2009

NOTE: The calibration interval of the above test instruments is 12 months and the calibrations are traceable to NML/ROC and NIST/USA.

4.3.3 TEST PROCEDURE

The transmitter output was connected to the spectrum analyzer through an attenuator. The bandwidth of the fundamental frequency was measured by spectrum analyzer with 100kHz RBW and 300kHz VBW. The 6dB bandwidth is defined as the total spectrum the power of which is higher than peak power minus 6dB.

4.3.4 DEVIATION FROM TEST STANDARD

No deviation.

4.3.5 TEST SETUP

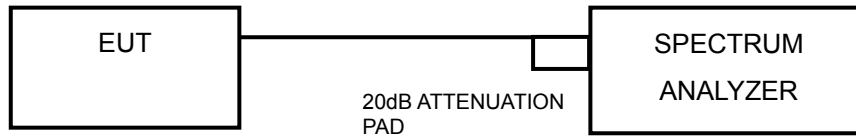

4.3.6 EUT OPERATING CONDITIONS

The software provided by client to enable the EUT under transmission condition continuously at lowest, middle and highest channel frequencies individually.



A D T

4.3.7 TEST RESULTS

802.11b DSSS MODULATION

MODULATION TYPE	DBPSK	TRANSFER RATE	1.0Mbps
INPUT POWER	120Vac, 60Hz	ENVIRONMENTAL CONDITIONS	21 deg.C, 66 %RH, 1021hPa
TESTED BY	Brad Wu		

CHANNEL	CHANNEL FREQUENCY (MHz)	6dB BANDWIDTH (MHz)	MINIMUM LIMIT (MHz)	PASS / FAIL
1	2412	12.23	0.5	PASS
6	2437	12.24	0.5	PASS
11	2462	12.22	0.5	PASS

CH 1

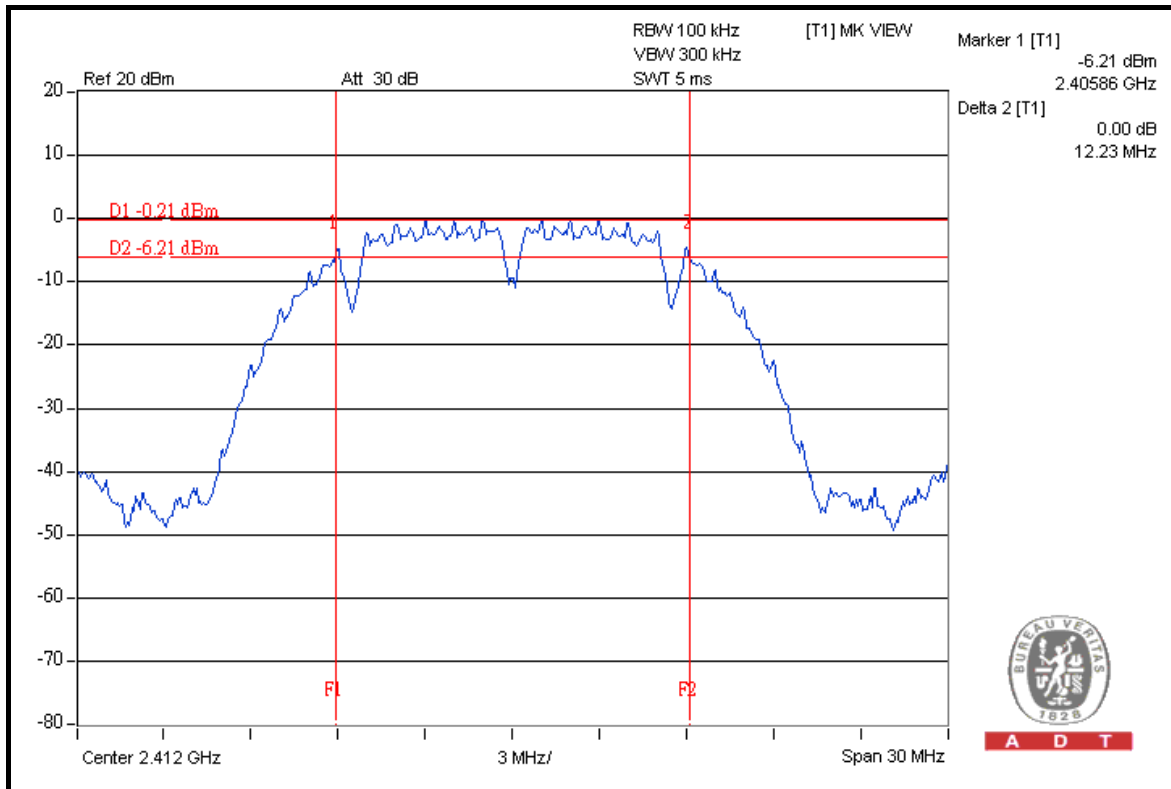

A D T



A D T

CH 6

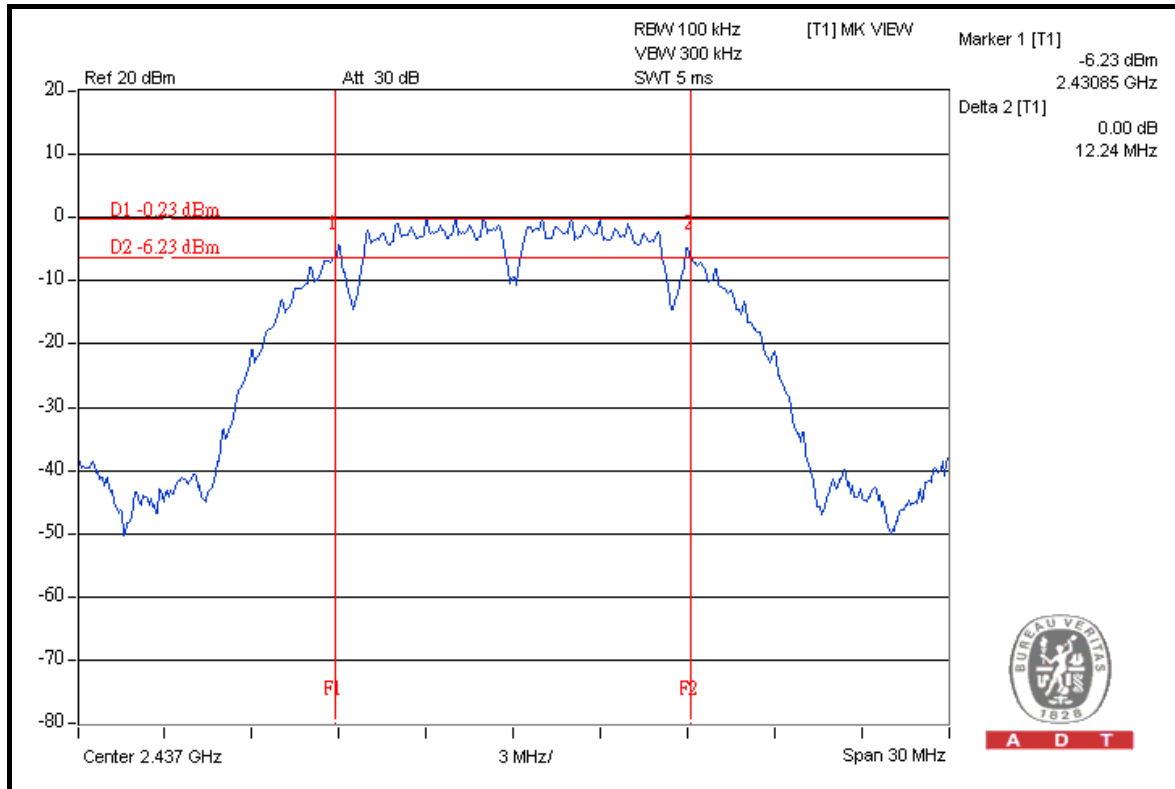

CH 11

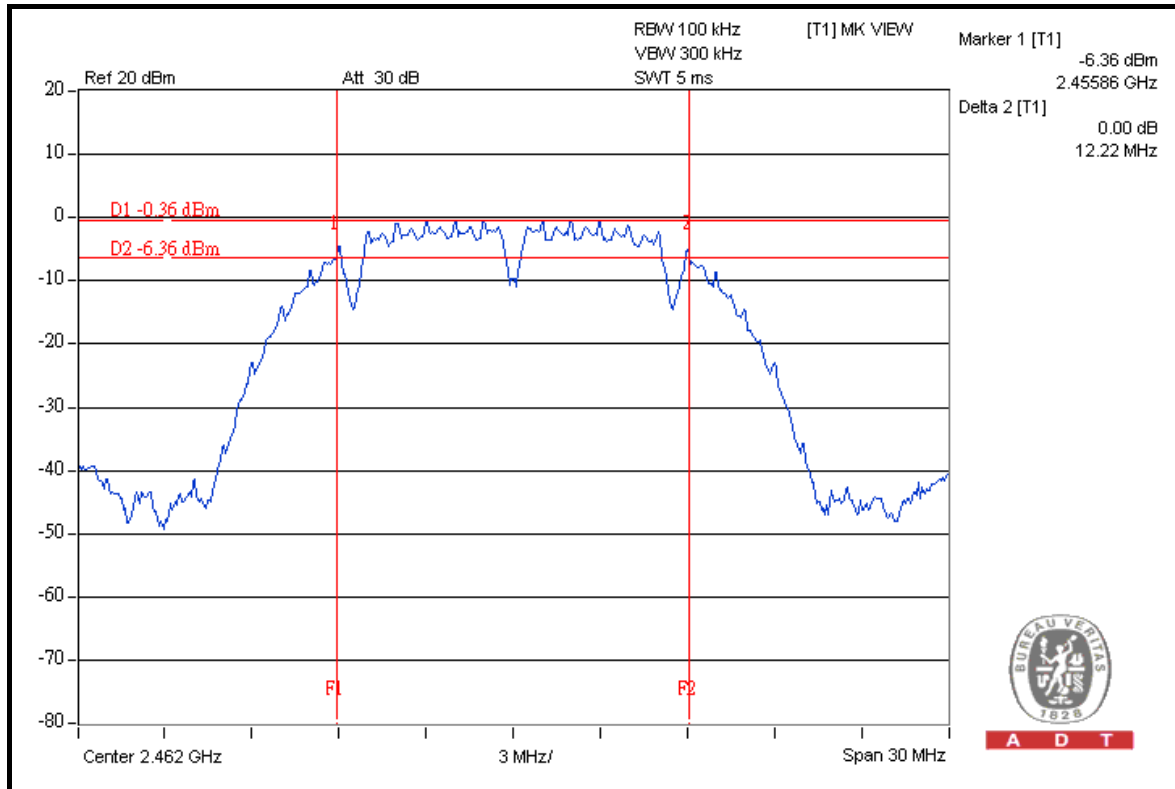



A D T

802.11g OFDM MODULATION

MODULATION TYPE	BPSK	TRANSFER RATE	6.0Mbps
INPUT POWER	120Vac, 60Hz	ENVIRONMENTAL CONDITIONS	21 deg.C, 66 %RH, 1021hPa
TESTED BY	Brad Wu		

CHANNEL	CHANNEL FREQUENCY (MHz)	6dB BANDWIDTH (MHz)	MINIMUM LIMIT (MHz)	PASS / FAIL
1	2412	16.56	0.5	PASS
6	2437	16.60	0.5	PASS
11	2462	16.59	0.5	PASS

CH 1

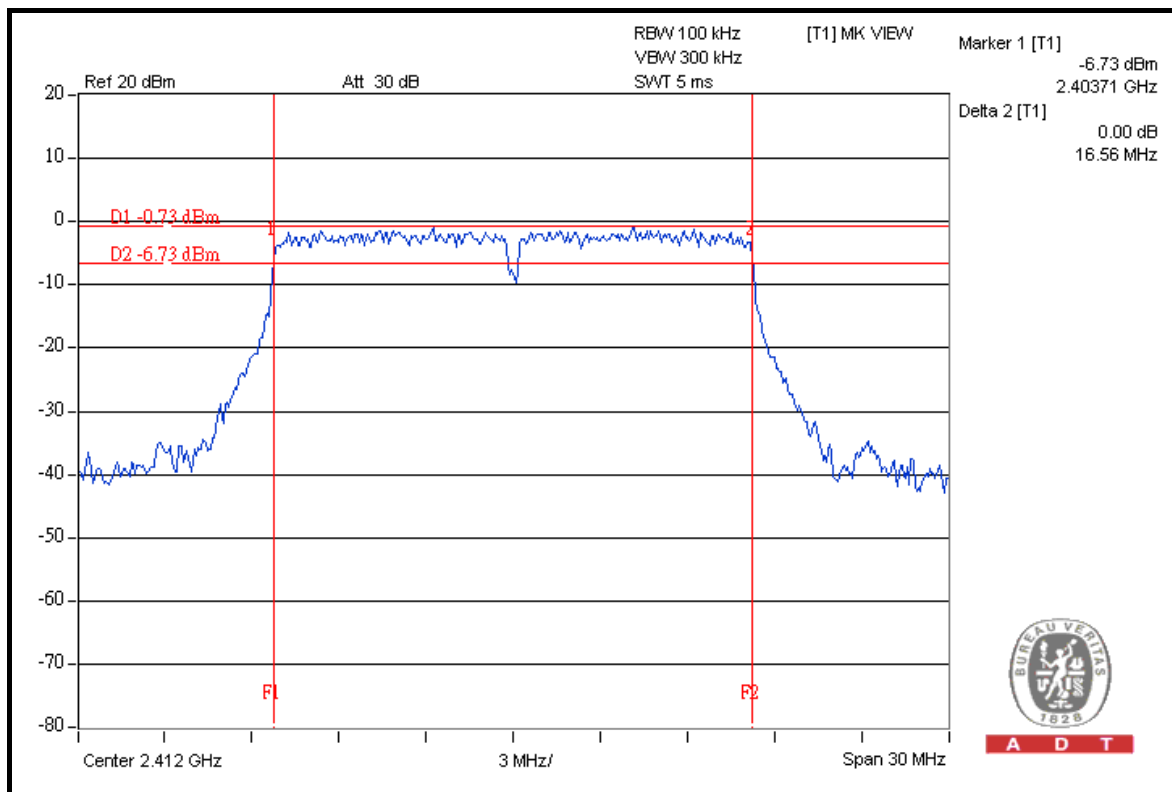

A D T



A D T

CH 6

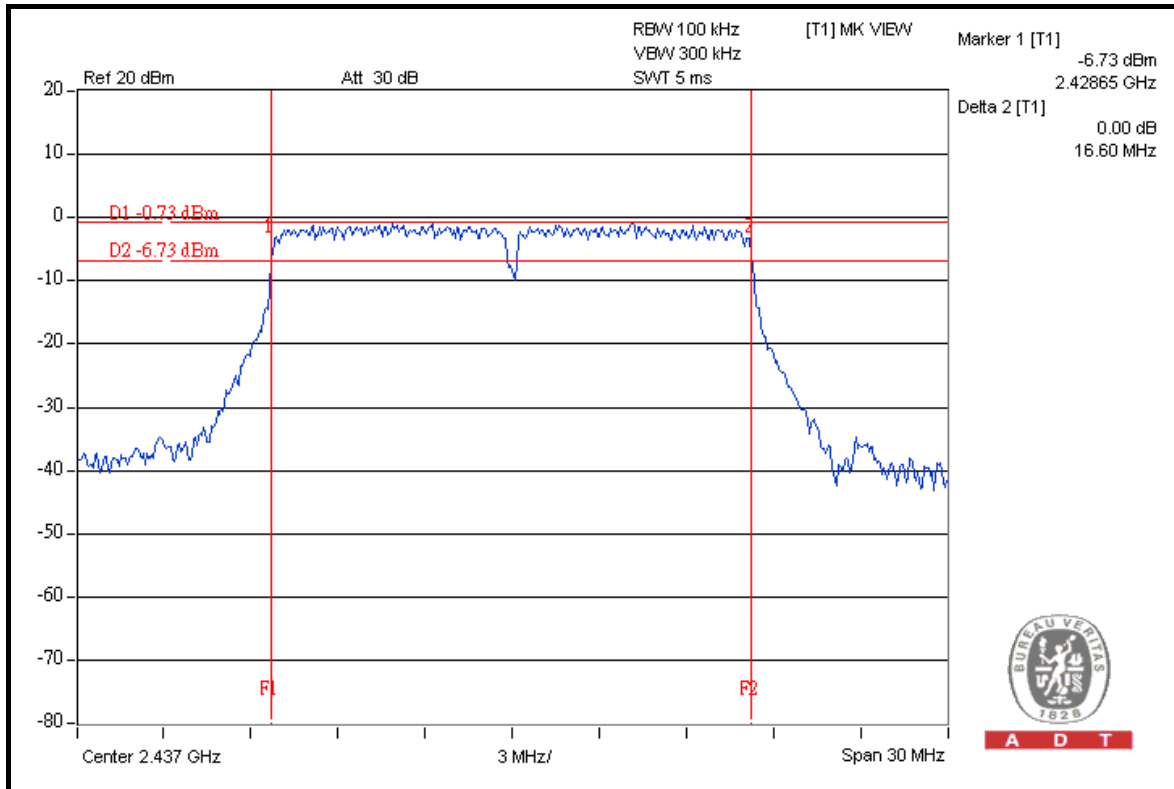

CH 11

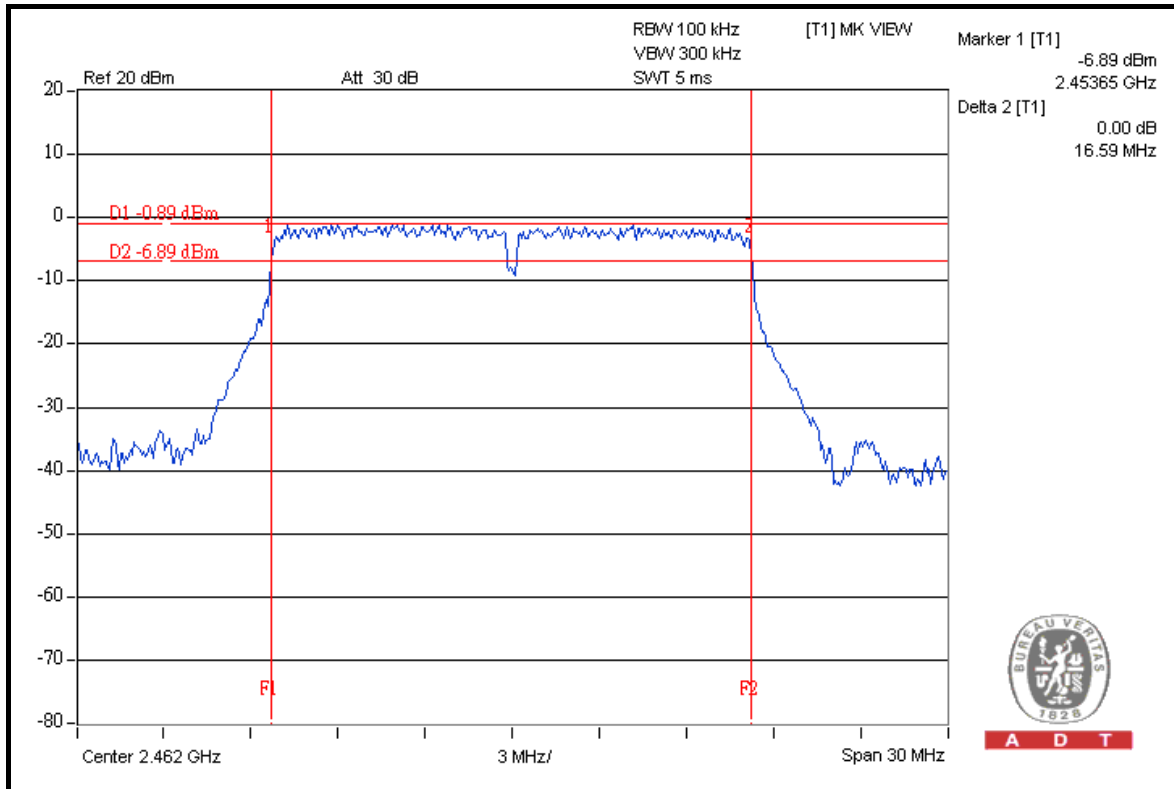



A D T

DRAFT 802.11n (20MHz) OFDM MODULATION

MODULATION TYPE	BPSK	TRANSFER RATE	7.2Mbps
INPUT POWER	120Vac, 60Hz	ENVIRONMENTAL CONDITIONS	21 deg.C, 66 %RH, 1021hPa
TESTED BY	Brad Wu		

CHANNEL	CHANNEL FREQUENCY (MHz)	6dB BANDWIDTH (MHz)		MINIMUM LIMIT (MHz)	PASS / FAIL
		CHAIN 0	CHAIN 1		
1	2412	17.70	17.66	0.5	PASS
6	2437	17.71	17.66	0.5	PASS
11	2462	17.66	17.68	0.5	PASS



A D T

FOR CHAIN 0: CH 1

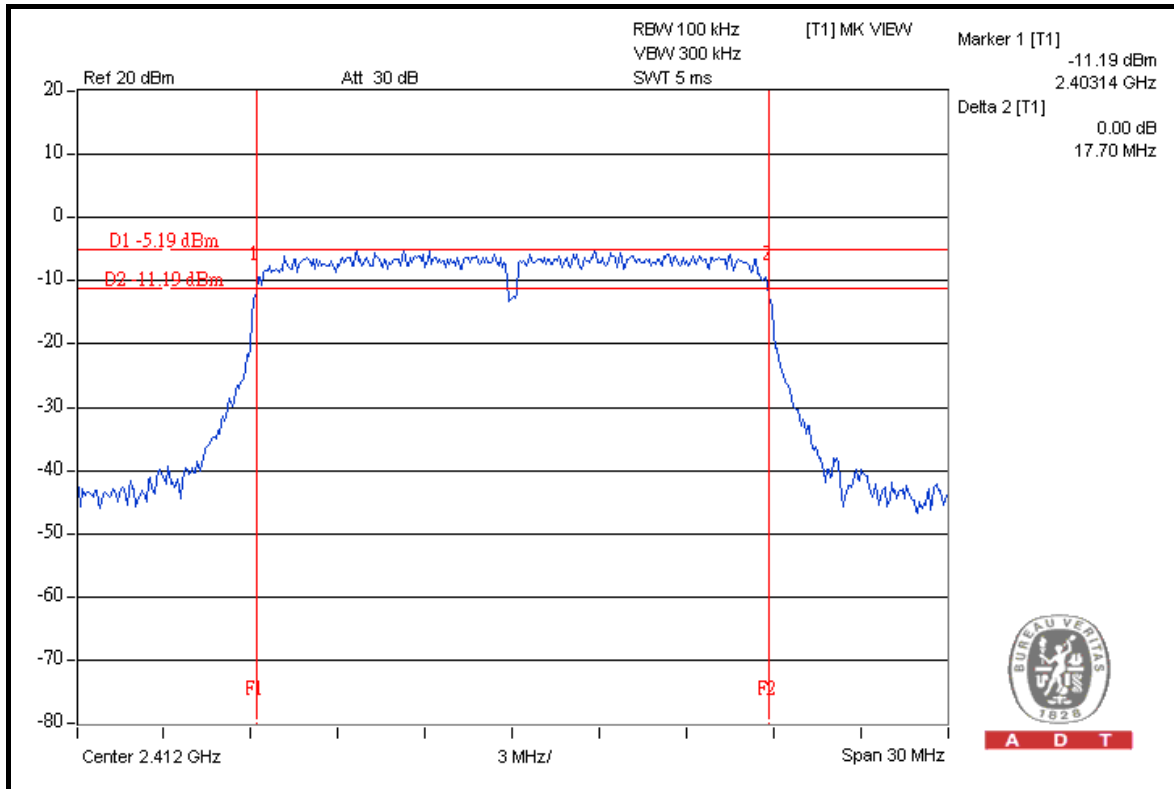

CH 6

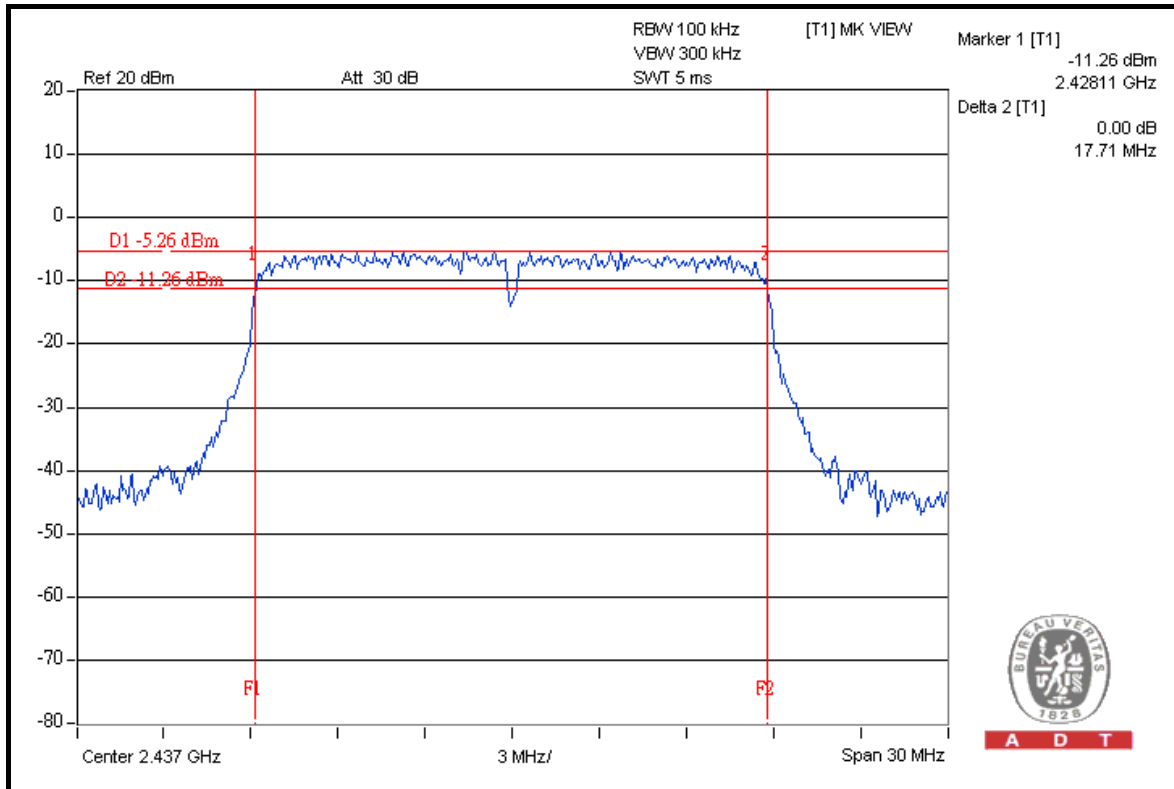



A D T

CH 11

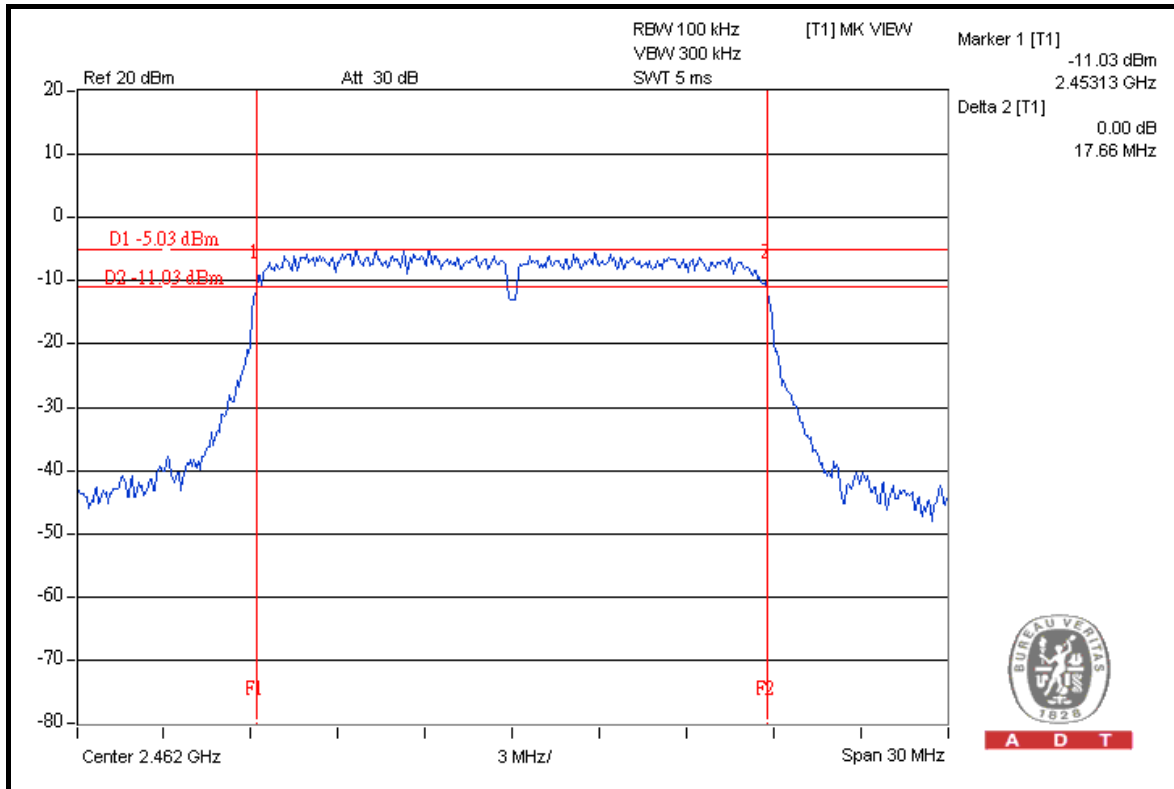

FOR CHAIN 1: CH 1

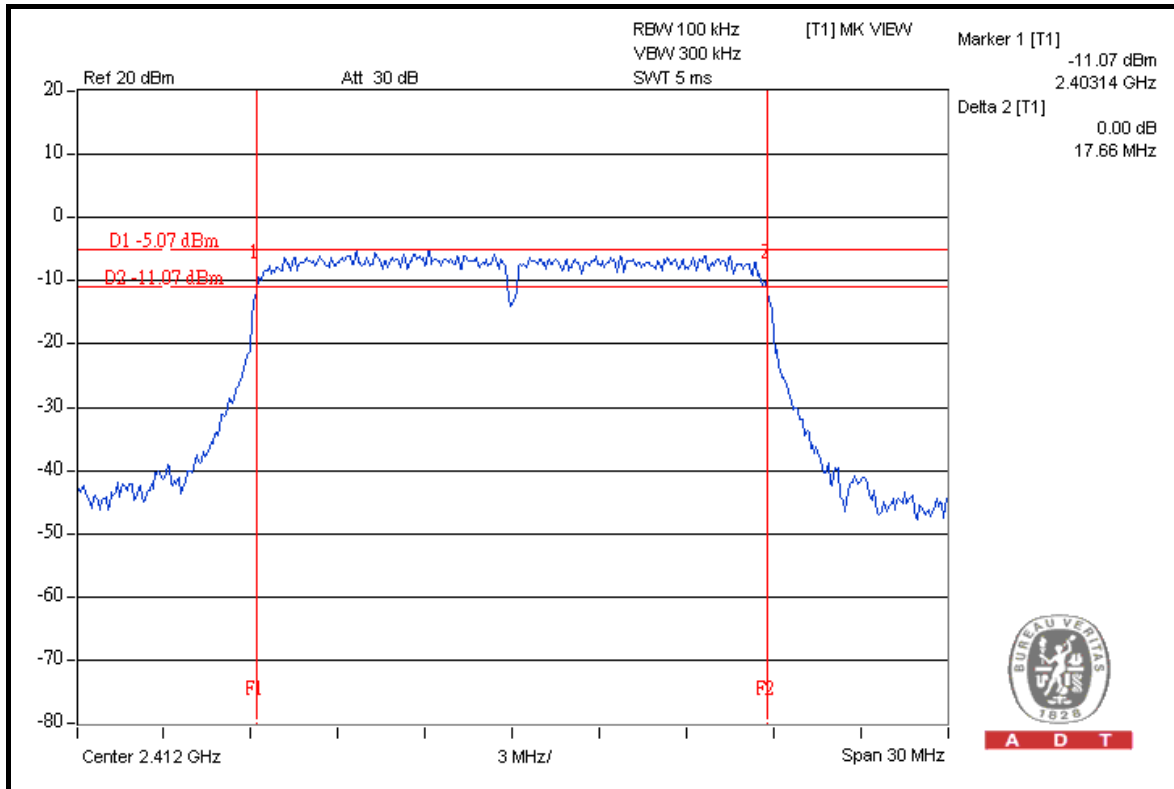



A D T

CH 6

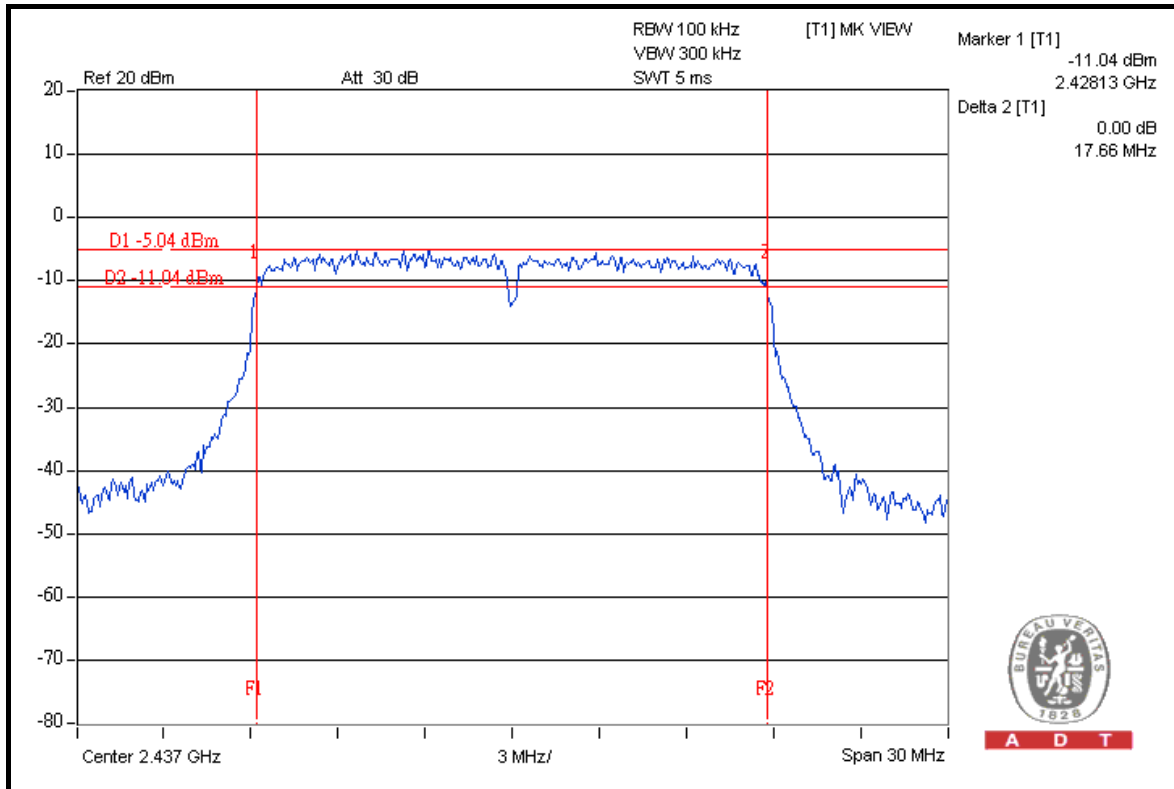

A D T

CH 11

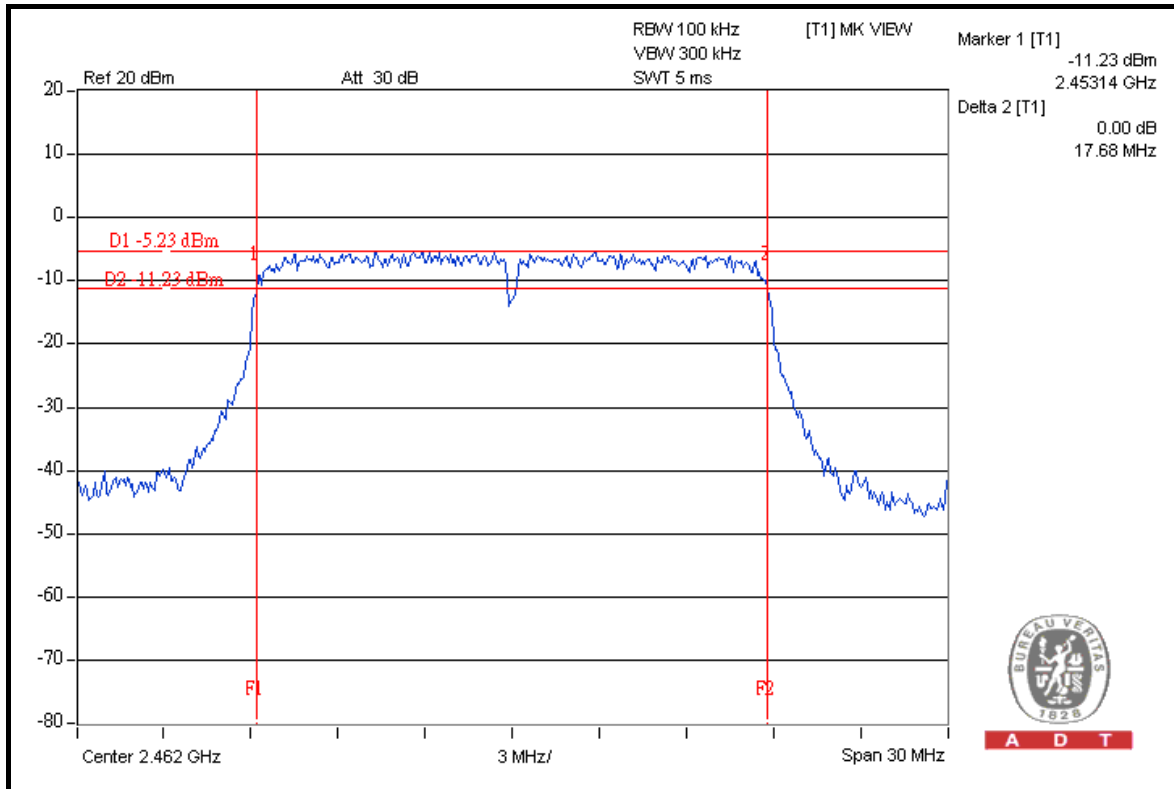

A D T



A D T

DRAFT 802.11n (40MHz) OFDM MODULATION

MODULATION TYPE	BPSK	TRANSFER RATE	15.0Mbps
INPUT POWER	120Vac, 60Hz	ENVIRONMENTAL CONDITIONS	21 deg.C, 66 %RH, 1021hPa
TESTED BY	Brad Wu		

CHANNEL	CHANNEL FREQUENCY (MHz)	6dB BANDWIDTH (MHz)		MINIMUM LIMIT (MHz)	PASS / FAIL
		CHAIN 0	CHAIN 1		
1	2422	36.12	36.41	0.5	PASS
4	2437	35.90	36.12	0.5	PASS
7	2452	36.47	36.24	0.5	PASS



A D T

FOR CHAIN 0: CH 1

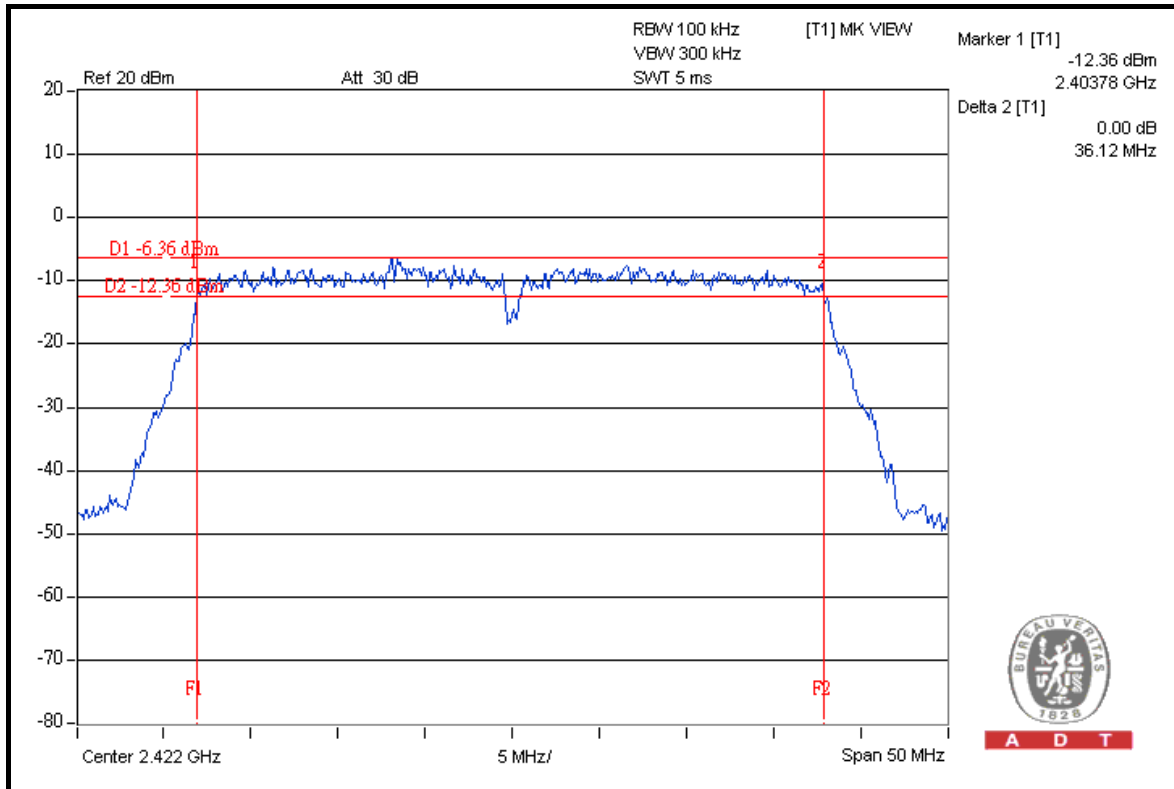

CH 4

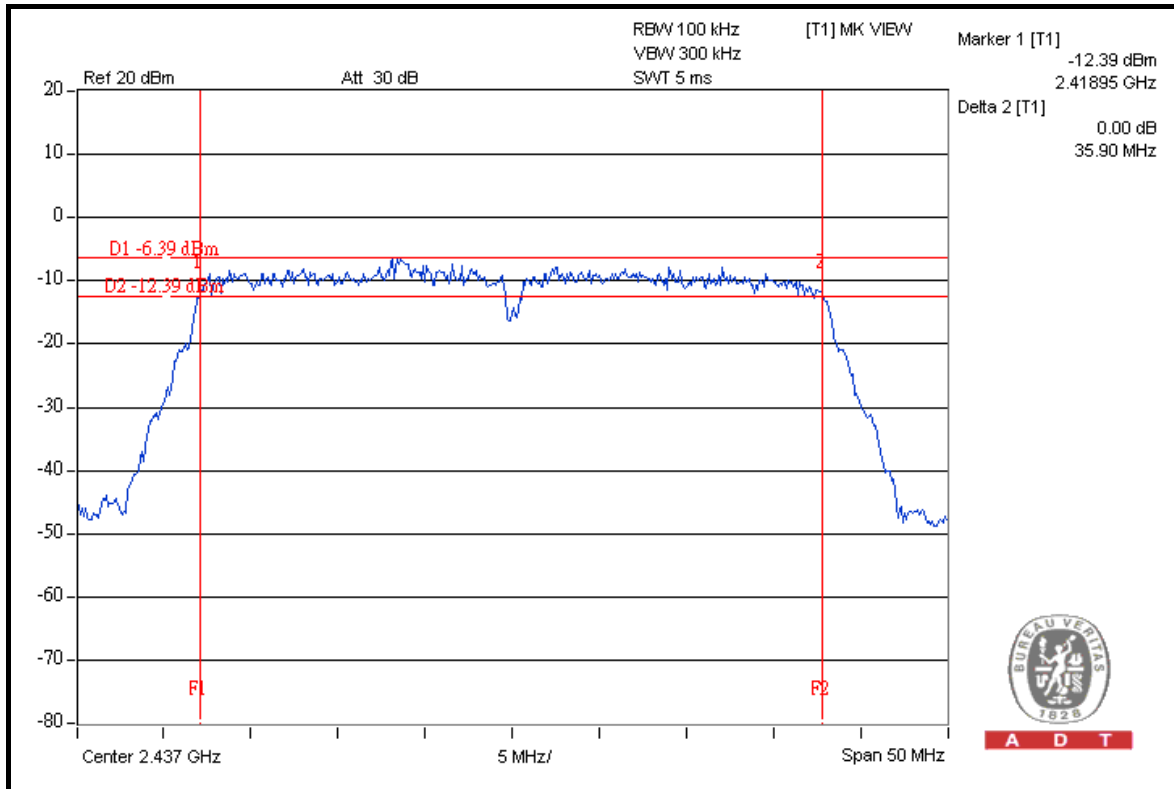



A D T

CH 7

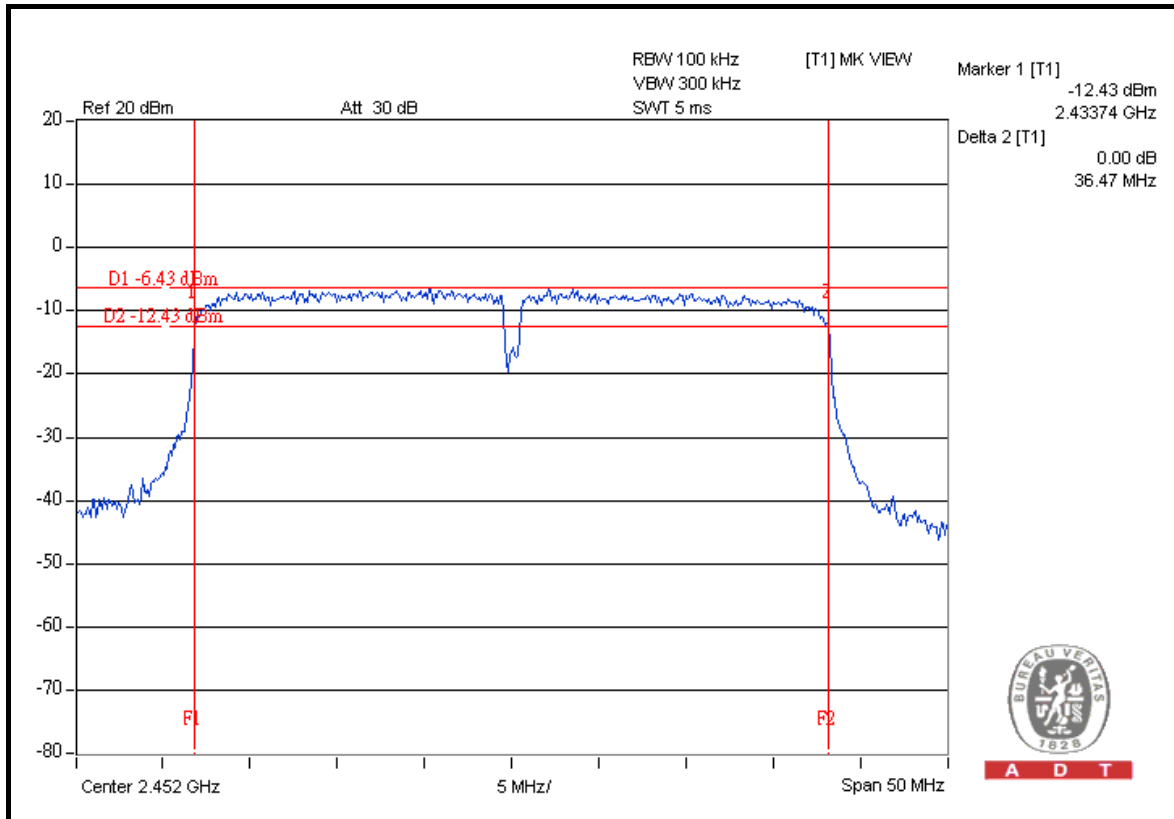

FOR CHAIN 1: CH 1

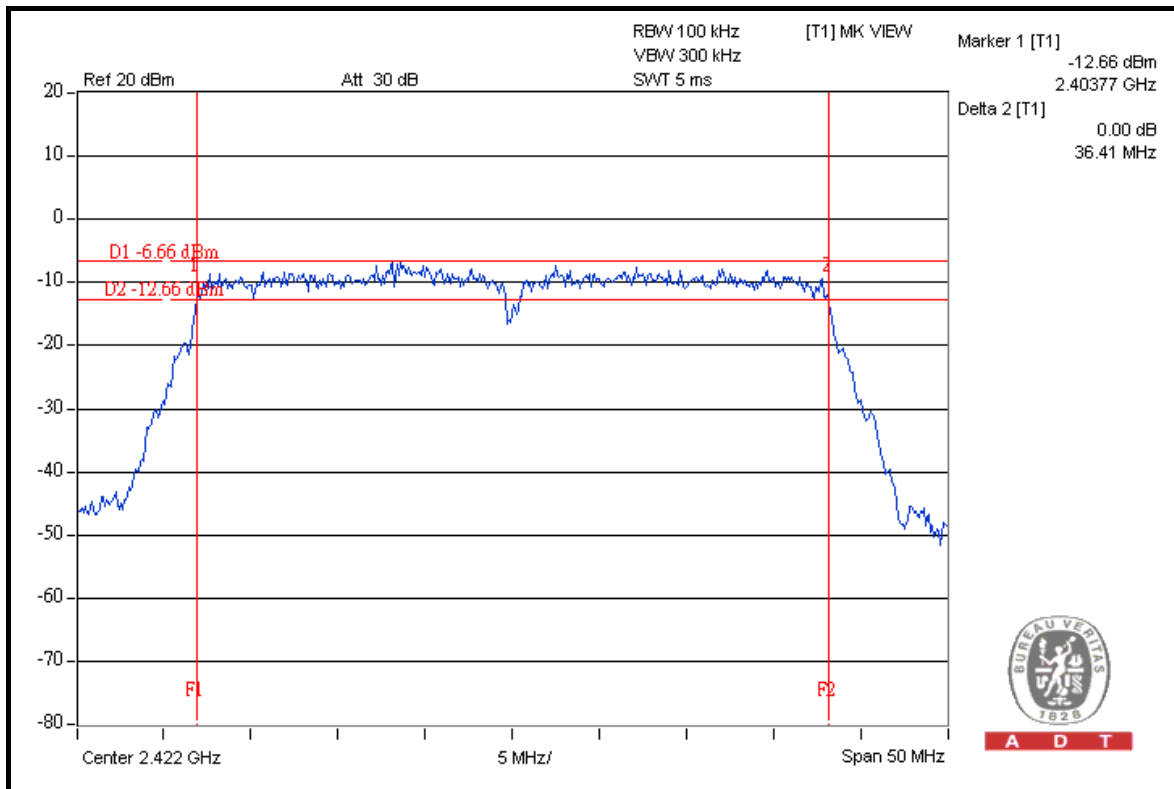



A D T

CH 4

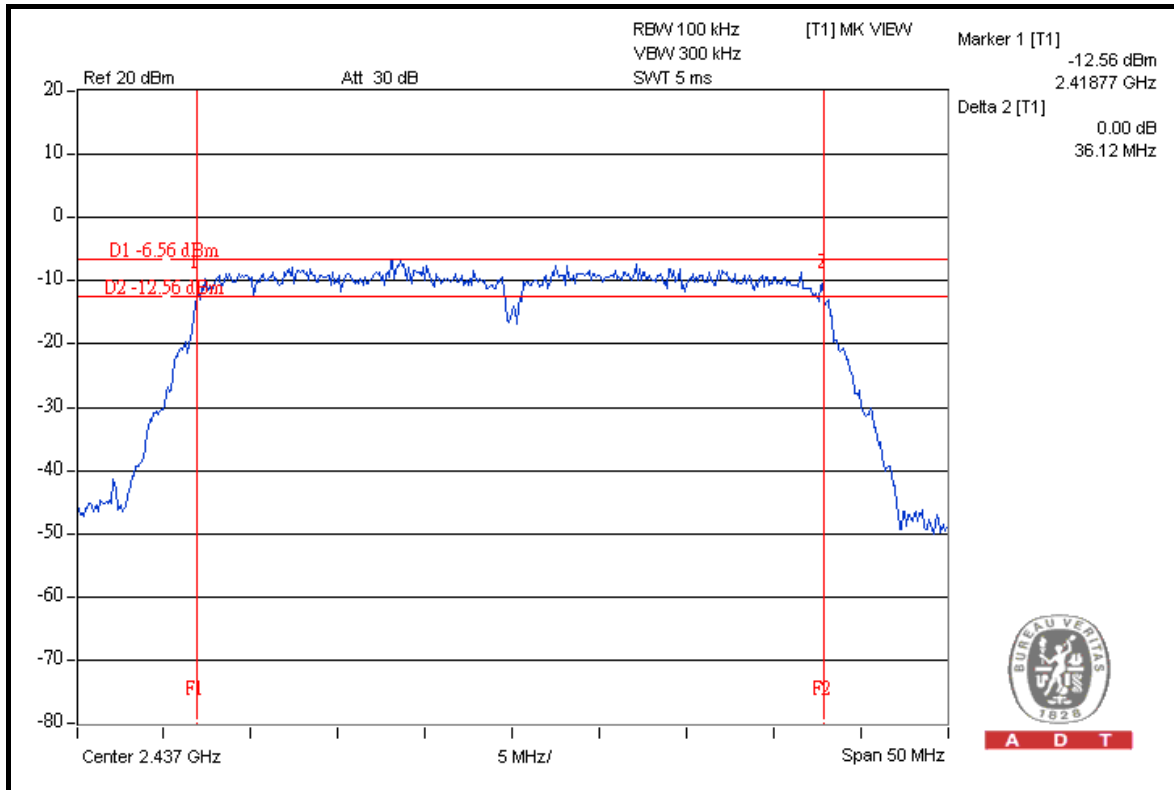

CH 7

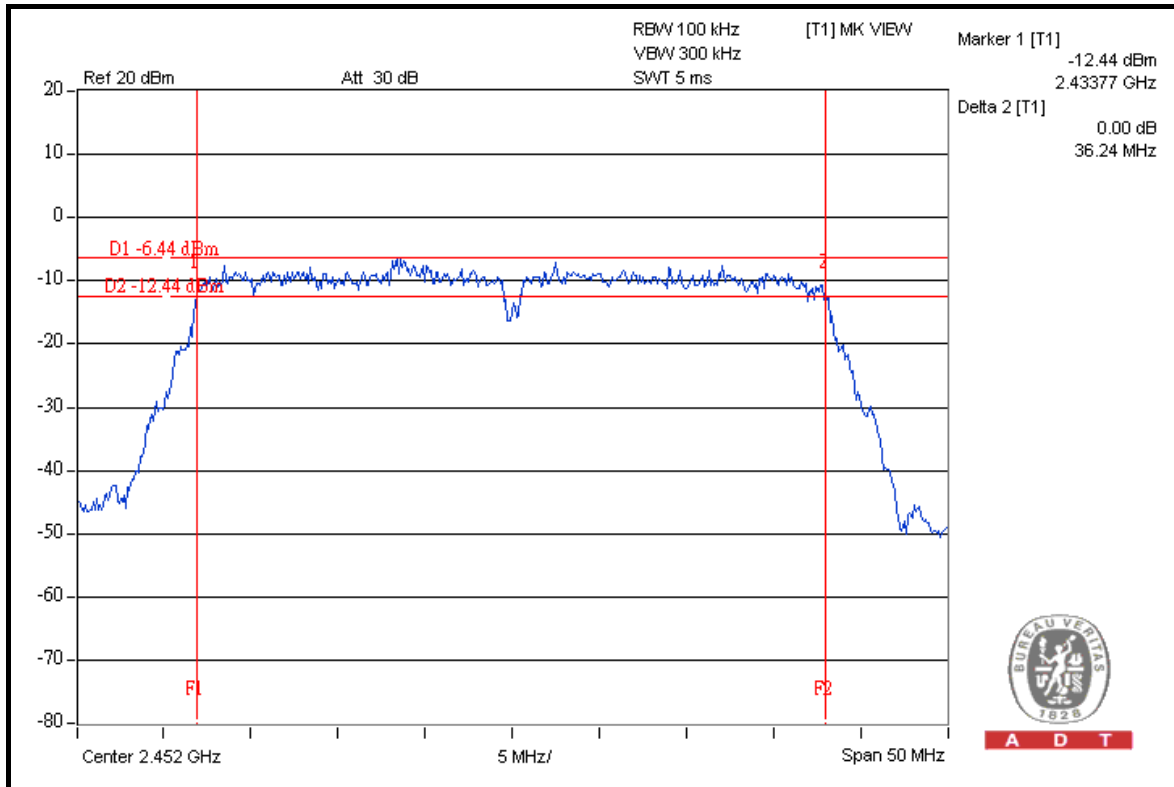



A D T

4.4 MAXIMUM PEAK OUTPUT POWER

4.4.1 LIMITS OF MAXIMUM PEAK OUTPUT POWER MEASUREMENT

The Maximum Peak Output Power Measurement is 30dBm.

4.4.2 INSTRUMENTS

DESCRIPTION & MANUFACTURER	MODEL NO.	SERIAL NO.	DATE OF CALIBRATION	DUE DATE OF CALIBRATION
High Speed Peak Power Meter	ML2495A	0824012	Aug. 04, 2008	Aug. 03, 2009
Power Sensor	MA2444B	0738138	Aug. 04, 2008	Aug. 03, 2009

NOTE:

1. The calibration interval of the above test instruments is 12 months and the calibrations are traceable to NML/ROC and NIST/USA.
2. Measurement Bandwidth of ML2495A is 65MHz greater than 6dB bandwidth of emission.

4.4.3 TEST PROCEDURES

A power sensor was used on the output port of the EUT. A power meter was used to read the response of the power sensor. Record the power level.

4.4.4 DEVIATION FROM TEST STANDARD

No deviation.

4.4.5 TEST SETUP

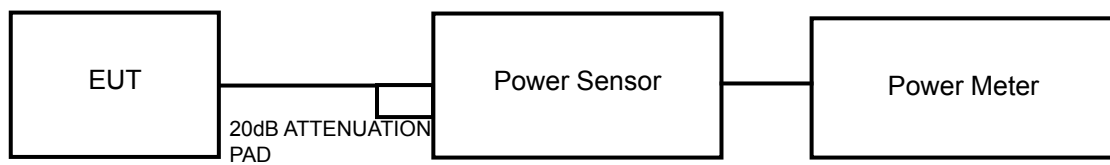

4.4.6 EUT OPERATING CONDITIONS

Same as Item 4.3.6.



A D T

4.4.7 TEST RESULTS

802.11b DSSS MODULATION

MODULATION TYPE	DBPSK	TRANSFER RATE	1.0Mbps
INPUT POWER	120Vac, 60Hz	ENVIRONMENTAL CONDITIONS	21 deg.C, 66 %RH, 1021hPa
TESTED BY	Brad Wu		

CHAN.	CHAN. FREQ. (MHz)	PEAK POWER OUTPUT (dBm)	PEAK POWER (mW)	PEAK POWER LIMIT (dBm)	PASS / FAIL
1	2412	15.06	32.063	30	PASS
6	2437	15.09	32.285	30	PASS
11	2462	15.04	31.915	30	PASS

802.11g OFDM MODULATION

MODULATION TYPE	BPSK	TRANSFER RATE	6.0Mbps
INPUT POWER	120Vac, 60Hz	ENVIRONMENTAL CONDITIONS	21 deg.C, 66 %RH, 1021hPa
TESTED BY	Brad Wu		

CHAN.	CHAN. FREQ. (MHz)	PEAK POWER OUTPUT (dBm)	PEAK POWER (mW)	PEAK POWER LIMIT (dBm)	PASS / FAIL
1	2412	23.53	225.424	30	PASS
6	2437	23.58	228.034	30	PASS
11	2462	23.56	226.986	30	PASS



A D T

DRAFT 802.11n (20MHz) OFDM MODULATION

MODULATION TYPE	BPSK	TRANSFER RATE	7.2Mbps
INPUT POWER	120Vac, 60Hz	ENVIRONMENTAL CONDITIONS	21 deg.C, 66 %RH, 1021hPa
TESTED BY	Brad Wu		

CHAN.	CHAN. FREQ. (MHz)	PEAK POWER OUTPUT (dBm)		TOTAL PEAK POWER (mW)	TOTAL PEAK POWER (dBm)	PEAK POWER LIMIT (dBm)	PASS / FAIL
		CHAIN 0	CHAIN 1				
1	2412	18.55	18.53	142.900	21.55	30	PASS
6	2437	18.57	18.59	144.222	21.59	30	PASS
11	2462	18.52	18.56	142.901	21.55	30	PASS

DRAFT 802.11n (40MHz) OFDM MODULATION

MODULATION TYPE	BPSK	TRANSFER RATE	15.0Mbps
INPUT POWER	120Vac, 60Hz	ENVIRONMENTAL CONDITIONS	24 deg.C, 66 %RH, 1021hPa
TESTED BY	Brad Wu		

CHAN.	CHAN. FREQ. (MHz)	PEAK POWER OUTPUT (dBm)		TOTAL PEAK POWER (mW)	TOTAL PEAK POWER (dBm)	PEAK POWER LIMIT (dBm)	PASS / FAIL
		CHAIN 0	CHAIN 1				
1	2422	17.56	17.54	113.771	20.56	30	PASS
4	2437	17.61	17.57	114.825	20.60	30	PASS
7	2452	17.58	17.52	113.773	20.56	30	PASS



4.5 POWER SPECTRAL DENSITY MEASUREMENT

4.5.1 LIMITS OF POWER SPECTRAL DENSITY MEASUREMENT

The Maximum of Power Spectral Density Measurement is 8dBm.

4.5.2 TEST INSTRUMENTS

DESCRIPTION & MANUFACTURER	MODEL NO.	SERIAL NO.	DATE OF CALIBRATION	DUE DATE OF CALIBRATION
R&S SPECTRUM ANALYZER	FSP40	100041	Apr. 22, 2008	Apr. 21, 2009

NOTE: The calibration interval of the above test instruments is 12 months and the calibrations are traceable to NML/ROC and NIST/USA.

4.5.3 TEST PROCEDURE

The transmitter output was connected to the spectrum analyzer through an attenuator, the bandwidth of the fundamental frequency was measured with the spectrum analyzer using 3kHz RBW and 30kHz VBW, set sweep time = span/3kHz. The power spectral density was measured and recorded.

The sweep time is allowed to be longer than span/3kHz for a full response of the mixer in the spectrum analyzer.

4.5.4 DEVIATION FROM TEST STANDARD

No deviation

4.5.5 TEST SETUP

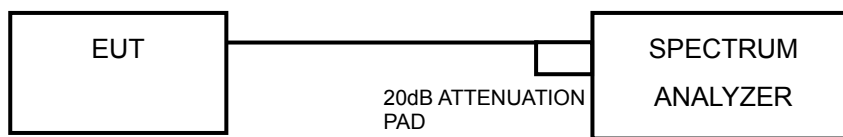

4.5.6 EUT OPERATING CONDITION

Same as Item 4.3.6



A D T

4.5.7 TEST RESULTS

802.11b DSSS MODULATION

MODULATION TYPE	DBPSK	TRANSFER RATE	1.0Mbps
INPUT POWER	120Vac, 60Hz	ENVIRONMENTAL CONDITIONS	24 deg.C, 66 %RH, 1021hPa
TESTED BY	Brad Wu		

CHAN.	CHAN. FREQ. (MHz)	RF POWER LEVEL IN 3kHz BW (dBm)	MAX. LIMIT (dBm)	PASS / FAIL
1	2412	-18.41	8	PASS
6	2437	-18.38	8	PASS
11	2462	-18.59	8	PASS

CH 1

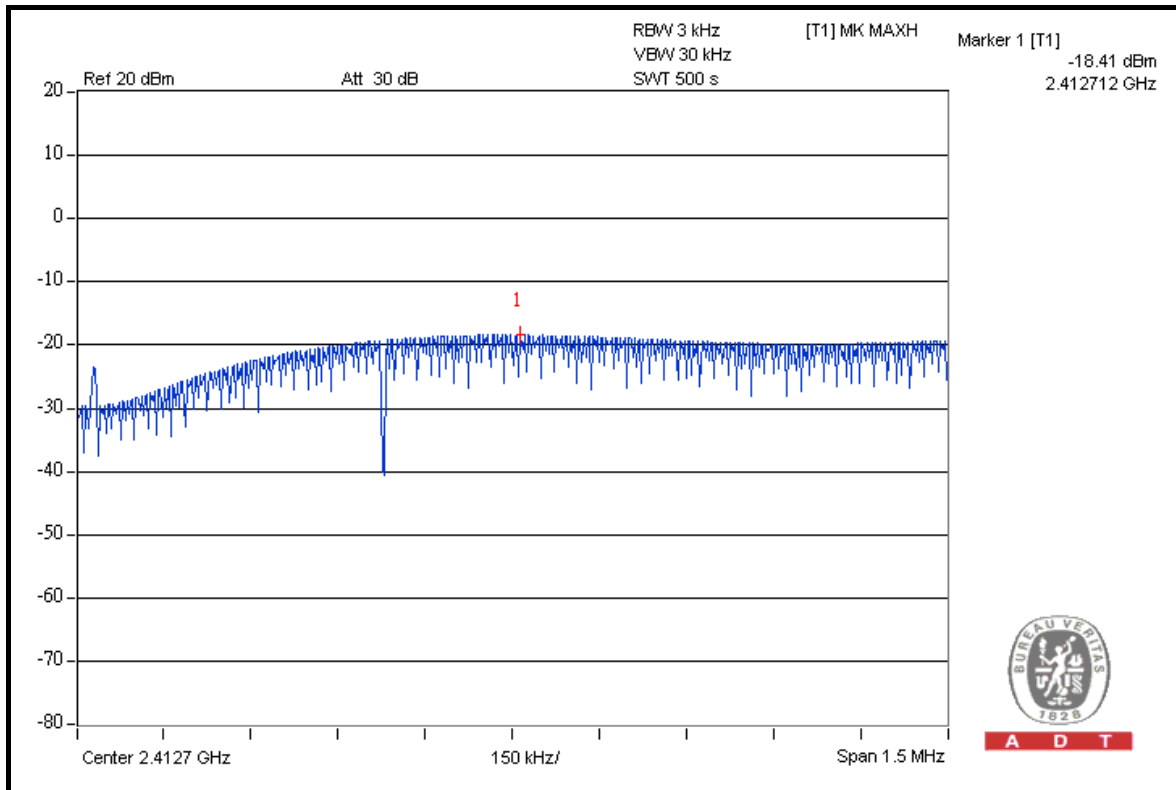

A D T



A D T

CH 6

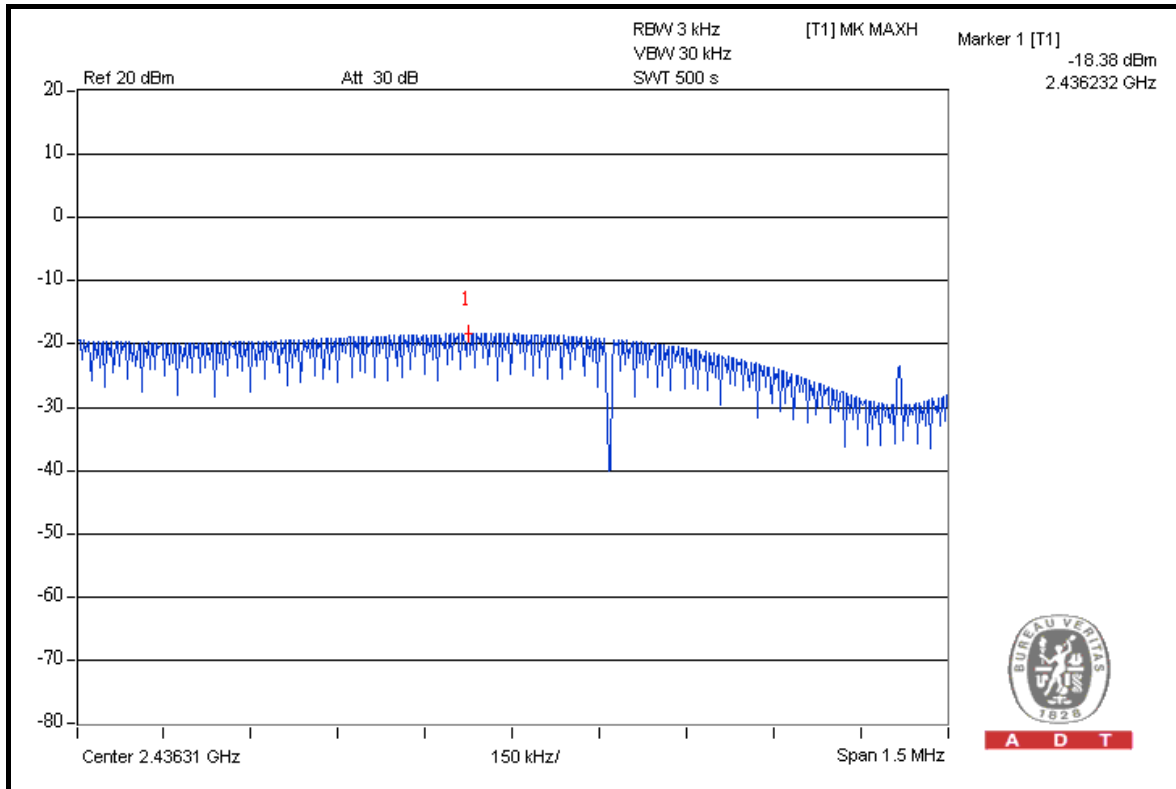

A D T

CH 11

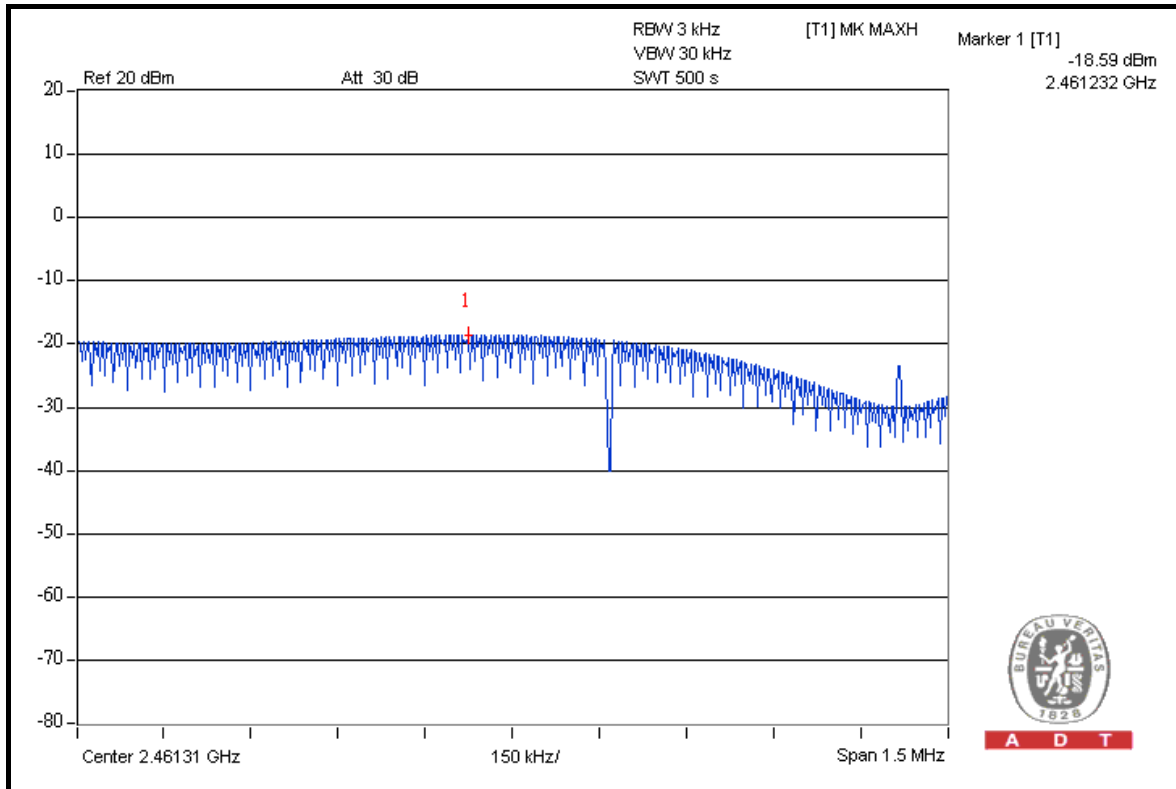

A D T



A D T

802.11g OFDM MODULATION

MODULATION TYPE	BPSK	TRANSFER RATE	6.0Mbps
INPUT POWER	120Vac, 60Hz	ENVIRONMENTAL CONDITIONS	21deg.C, 66%RH, 1021hPa
TESTED BY	Brad Wu		

CHAN.	CHAN. FREQ. (MHz)	RF POWER LEVEL IN 3kHz BW (dBm)	MAX. LIMIT (dBm)	PASS / FAIL
1	2412	-15.02	8	PASS
6	2437	-14.78	8	PASS
11	2462	-15.00	8	PASS

CH 1

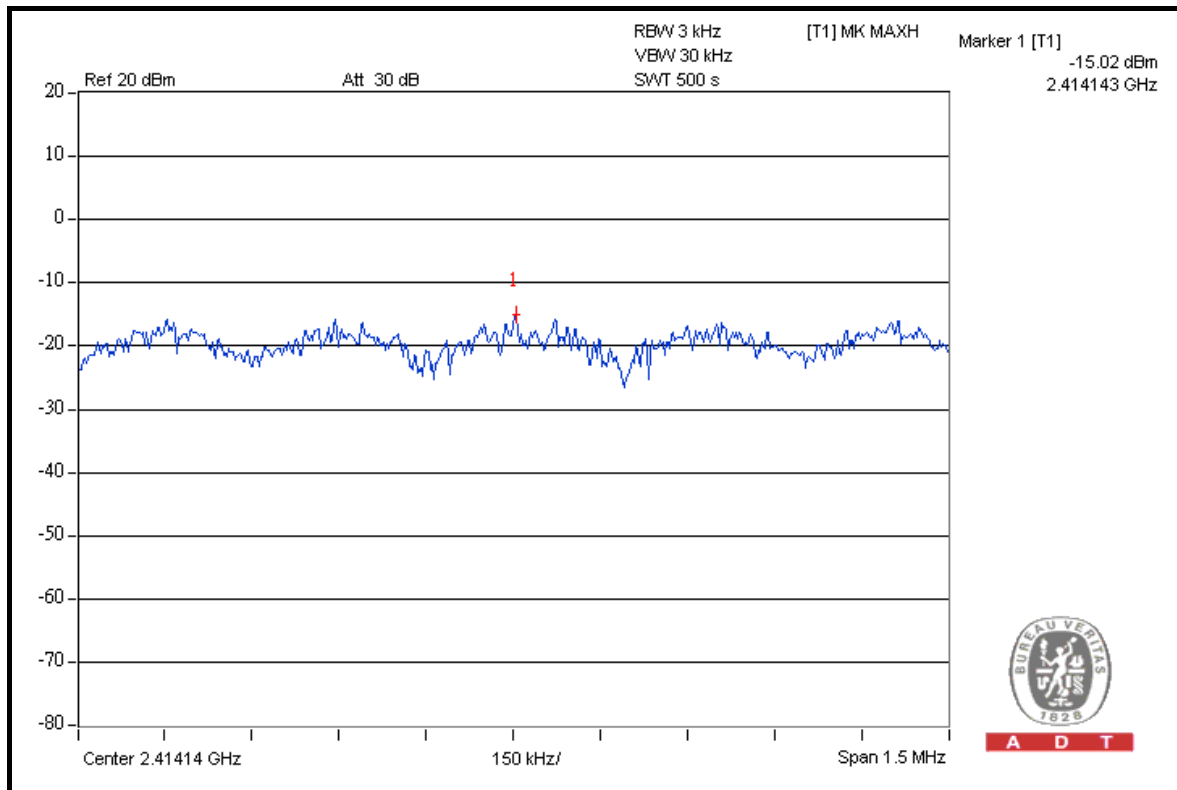

A D T



A D T

CH 6

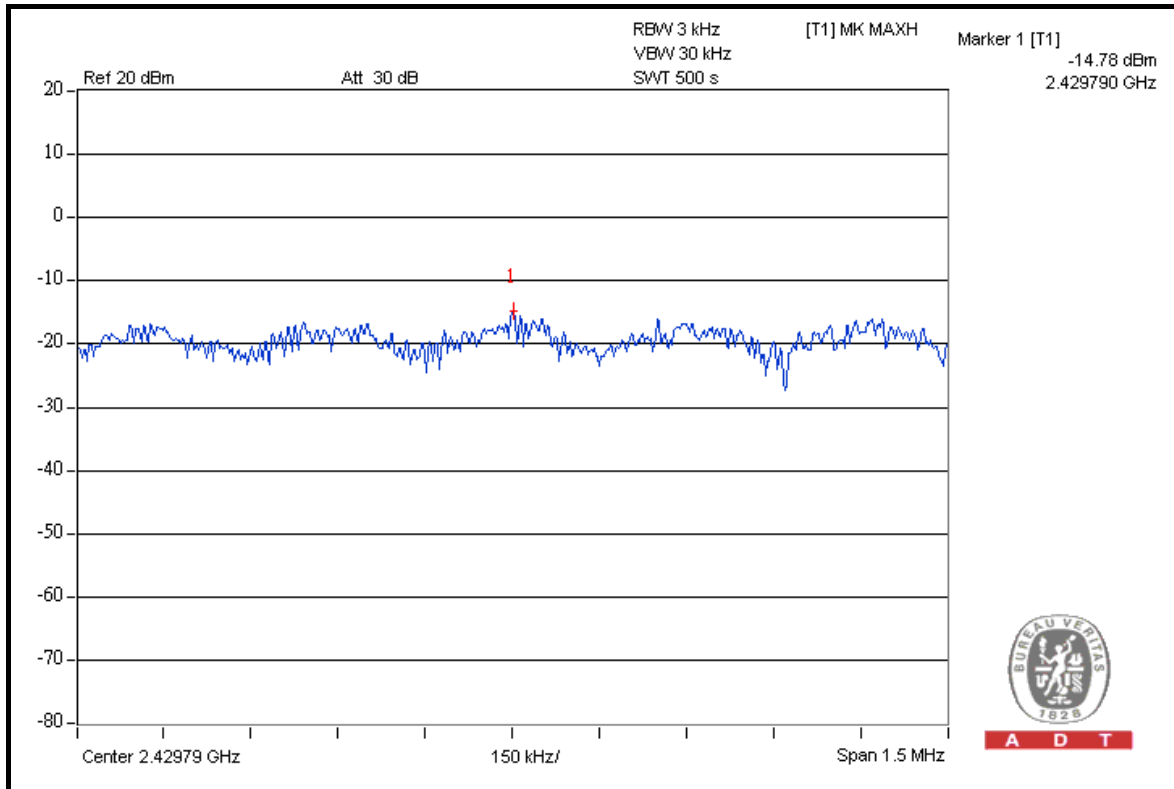

CH 11

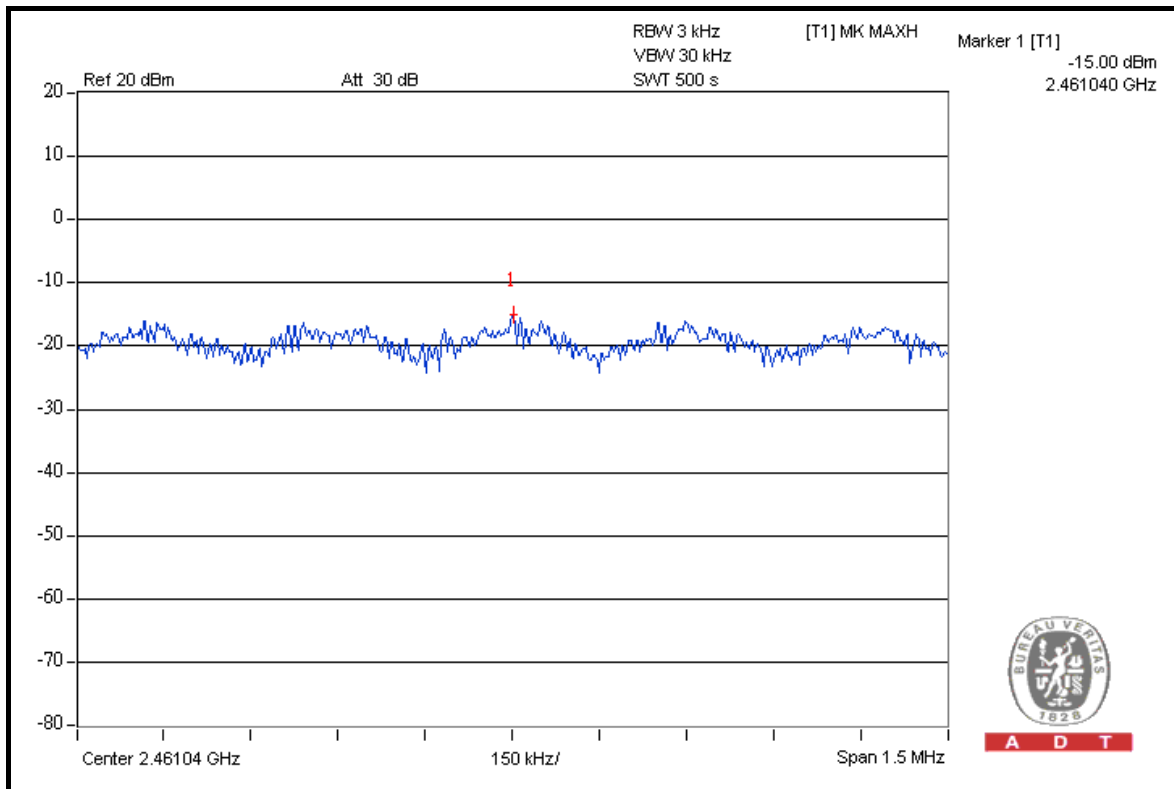



A D T

DRAFT 802.11n (20MHz) OFDM MODULATION

MODULATION TYPE	BPSK	TRANSFER RATE	7.2Mbps
INPUT POWER	120Vac, 60Hz	ENVIRONMENTAL CONDITIONS	21 deg.C, 66 %RH, 1021hPa
TESTED BY	Brad Wu		

CHAN.	CHAN. FREQ. (MHz)	RF POWER LEVEL IN 3kHz BW (dBm)		TOTAL POWER DENSITY (mW)	TOTAL POWER DENSITY (dBm)	MAX. LIMIT (dBm)	PASS / FAIL
		CHAIN 0	CHAIN 1				
1	2412	-18.20	-18.52	0.029	-15.35	8	PASS
6	2437	-18.22	-18.56	0.029	-15.38	8	PASS
11	2462	-18.04	-18.51	0.030	-15.26	8	PASS



A D T

FOR CHAIN 0: CH 1

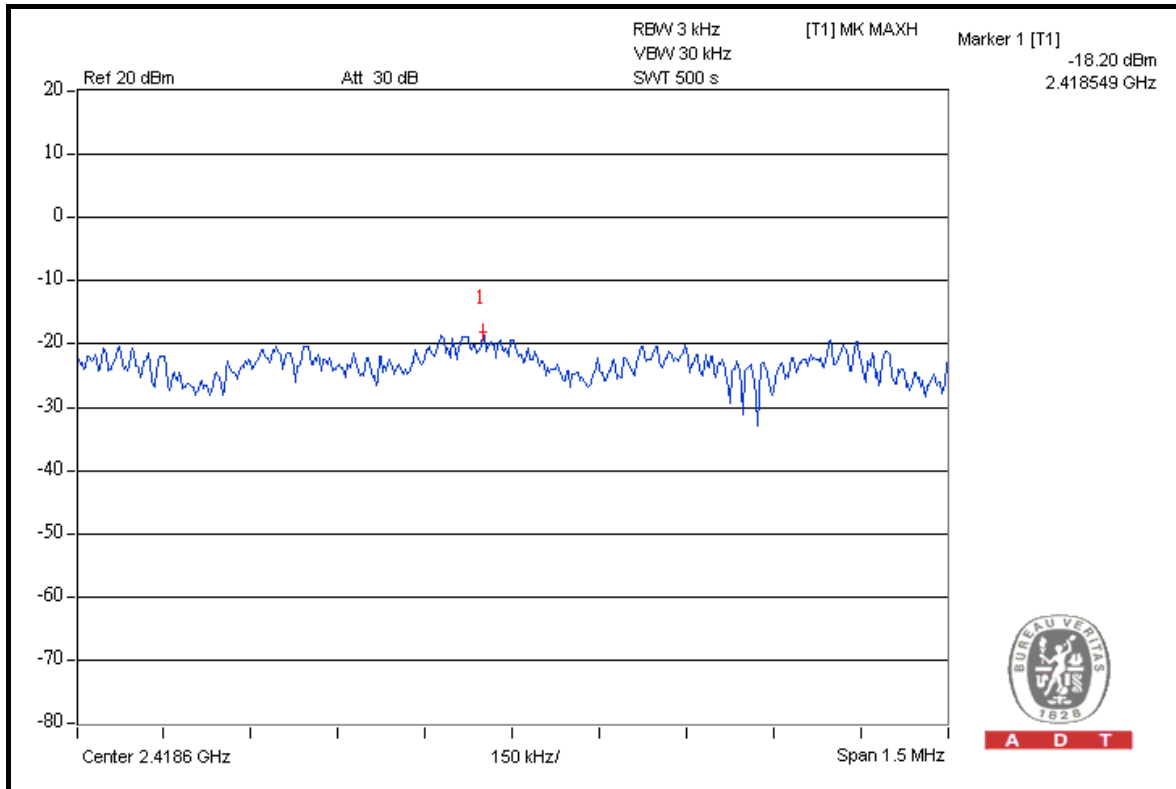

CH 6

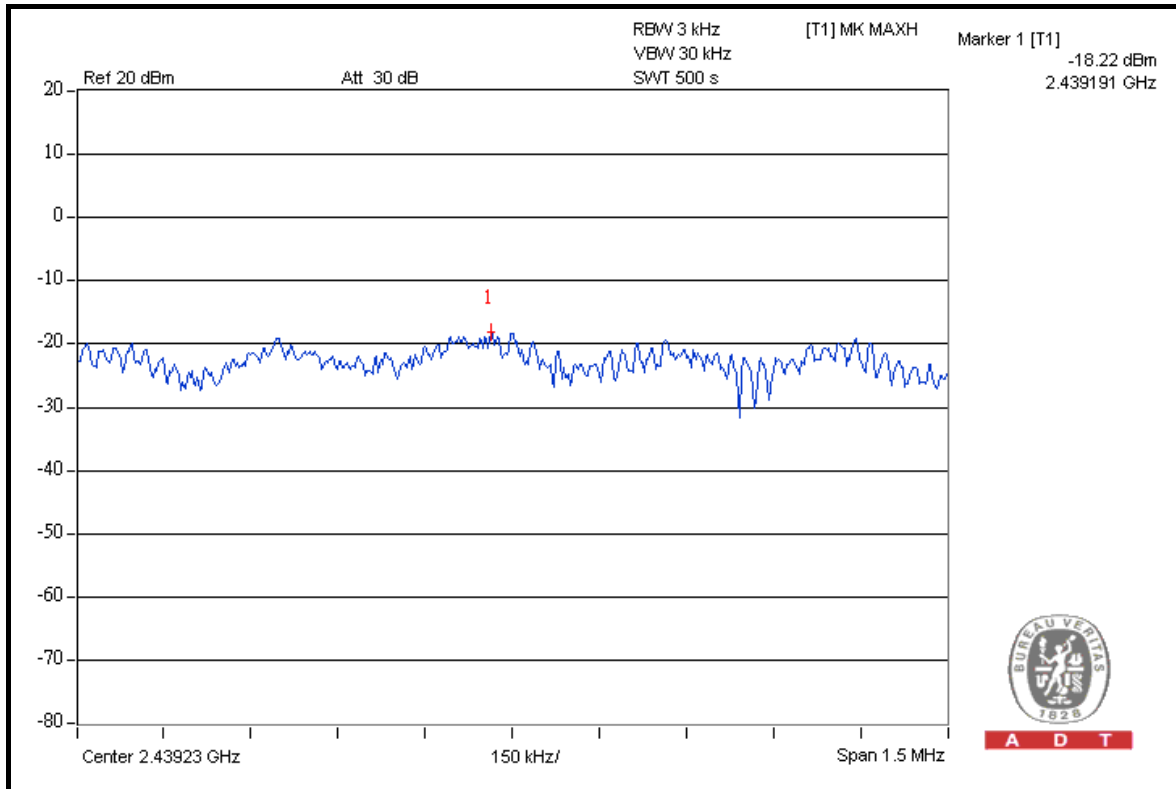



A D T

CH 11

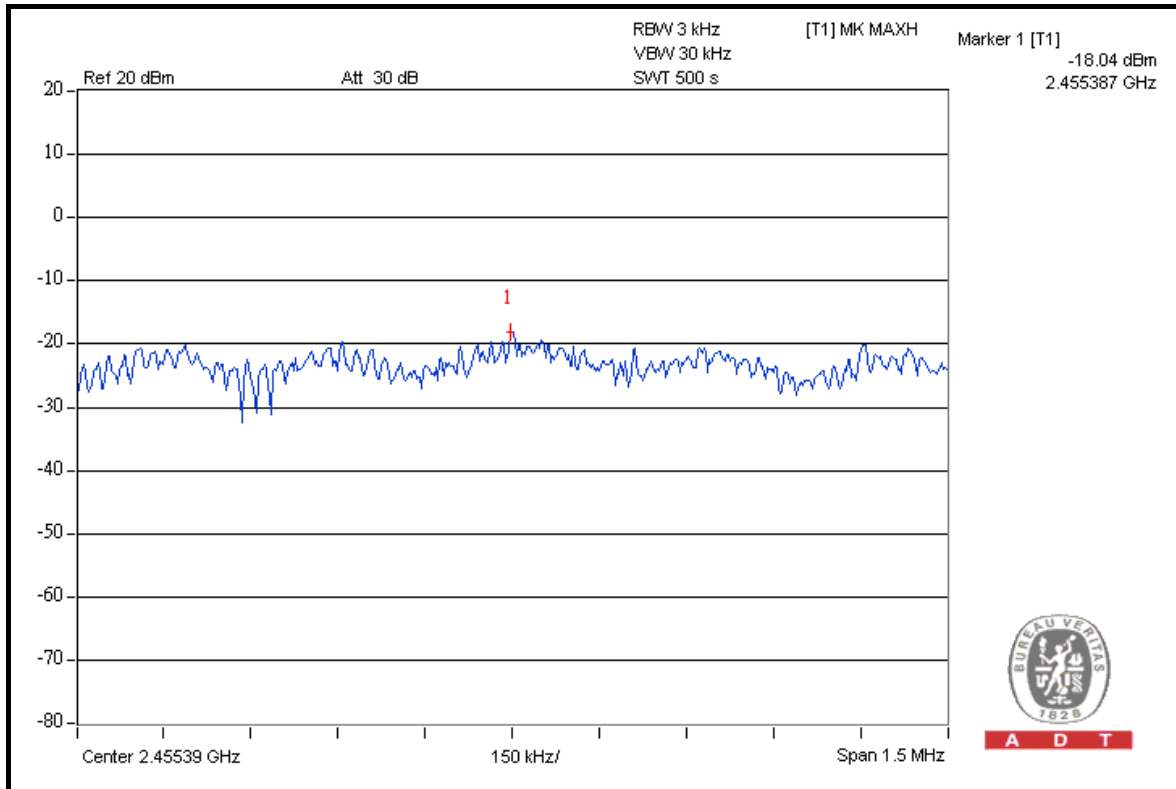

FOR CHAIN 1: CH 1

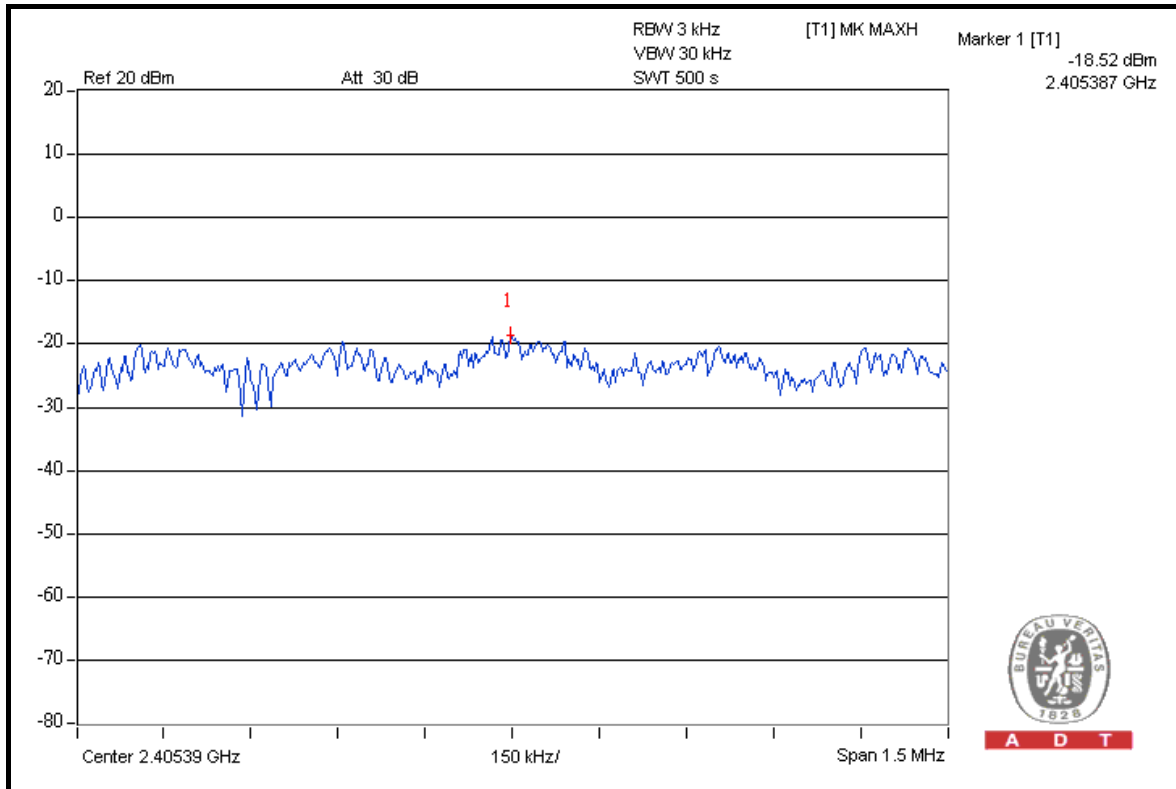



A D T

CH 6

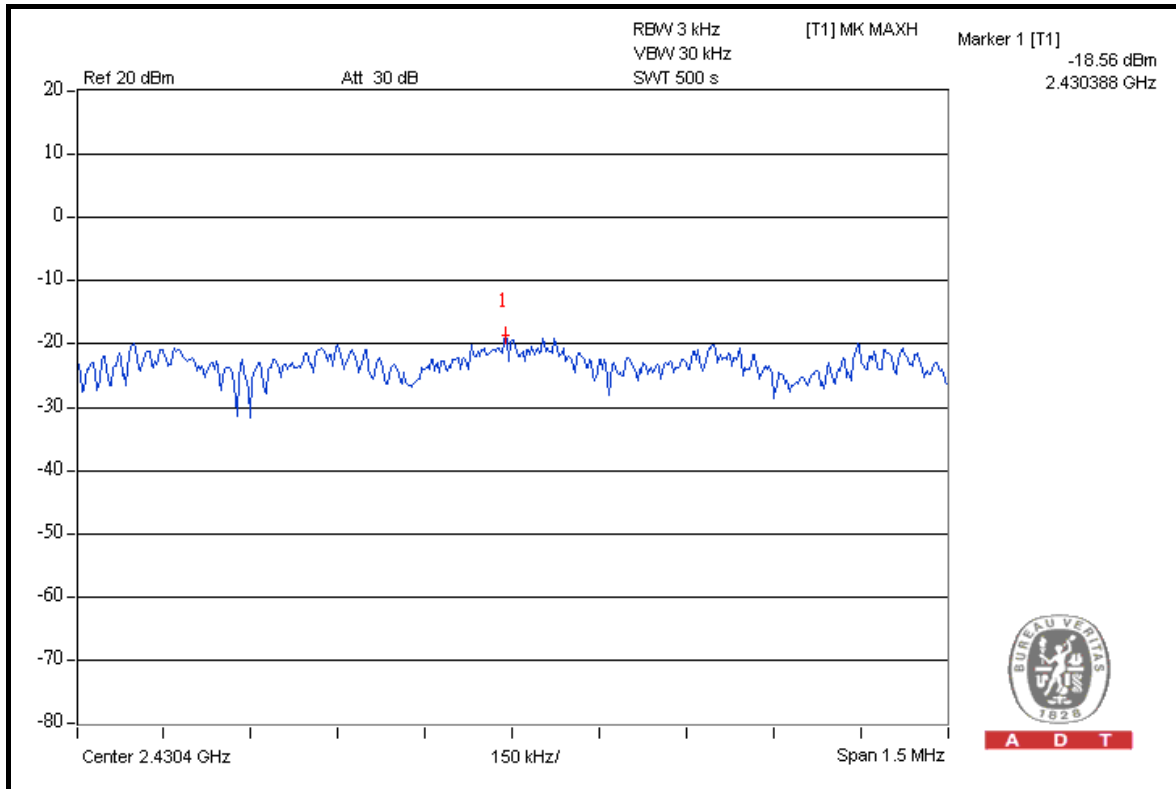

CH 11

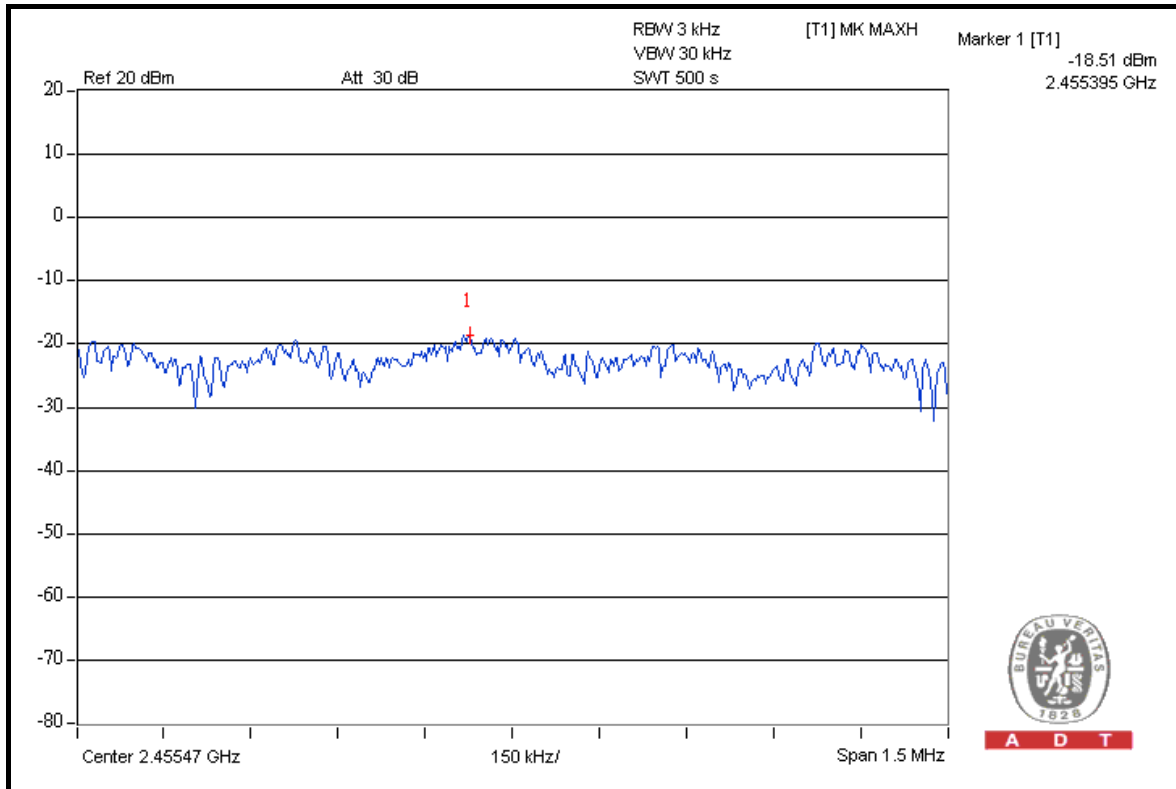



A D T

DRAFT 802.11n (40MHz) OFDM MODULATION

MODULATION TYPE	BPSK	TRANSFER RATE	15.0Mbps
INPUT POWER	120Vac, 60Hz	ENVIRONMENTAL CONDITIONS	21 deg.C, 66 %RH, 1021hPa
TESTED BY	Brad Wu		

CHAN.	CHAN. FREQ. (MHz)	RF POWER LEVEL IN 3kHz BW (dBm)		TOTAL POWER DENSITY (mW)	TOTAL POWER DENSITY (dBm)	MAX. LIMIT (dBm)	PASS / FAIL
		CHAIN 0	CHAIN 1				
1	2422	-21.41	-21.13	0.015	-18.26	8	PASS
4	2437	-21.24	-21.22	0.015	-18.22	8	PASS
7	2452	-21.21	-20.97	0.016	-18.08	8	PASS



A D T

FOR CHAIN 0: CH 1

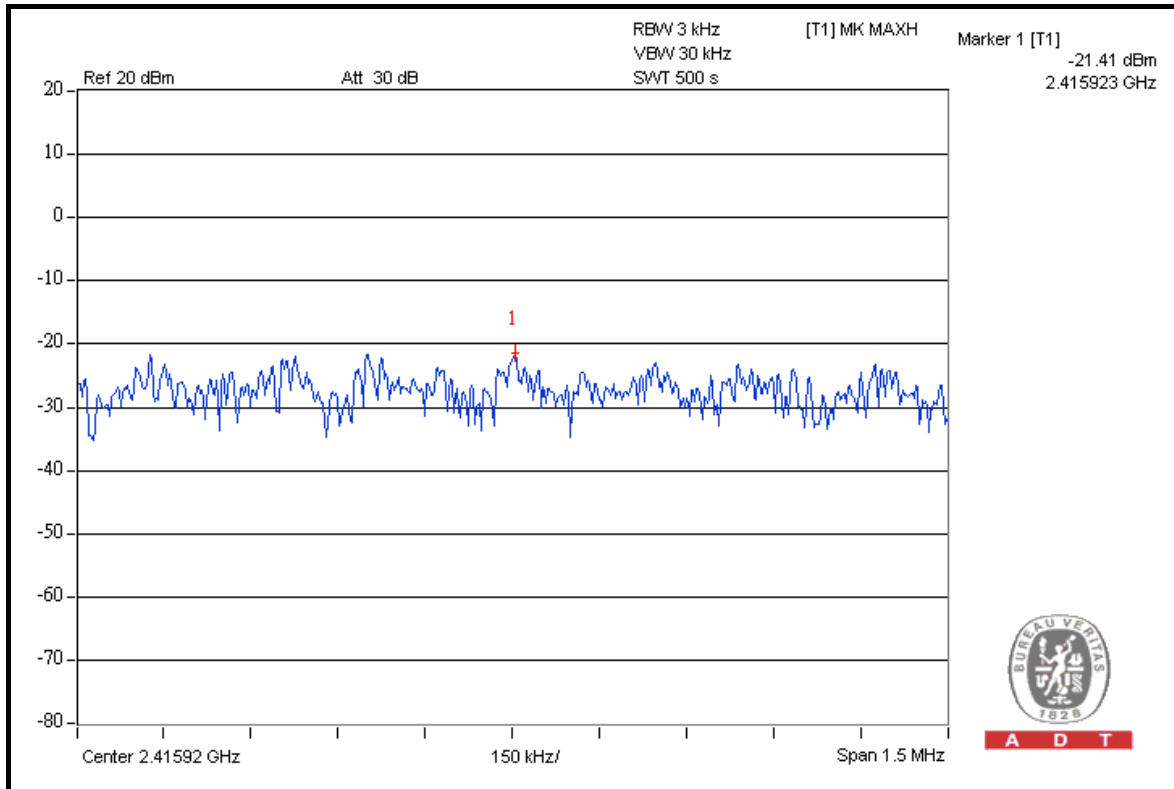

CH 4

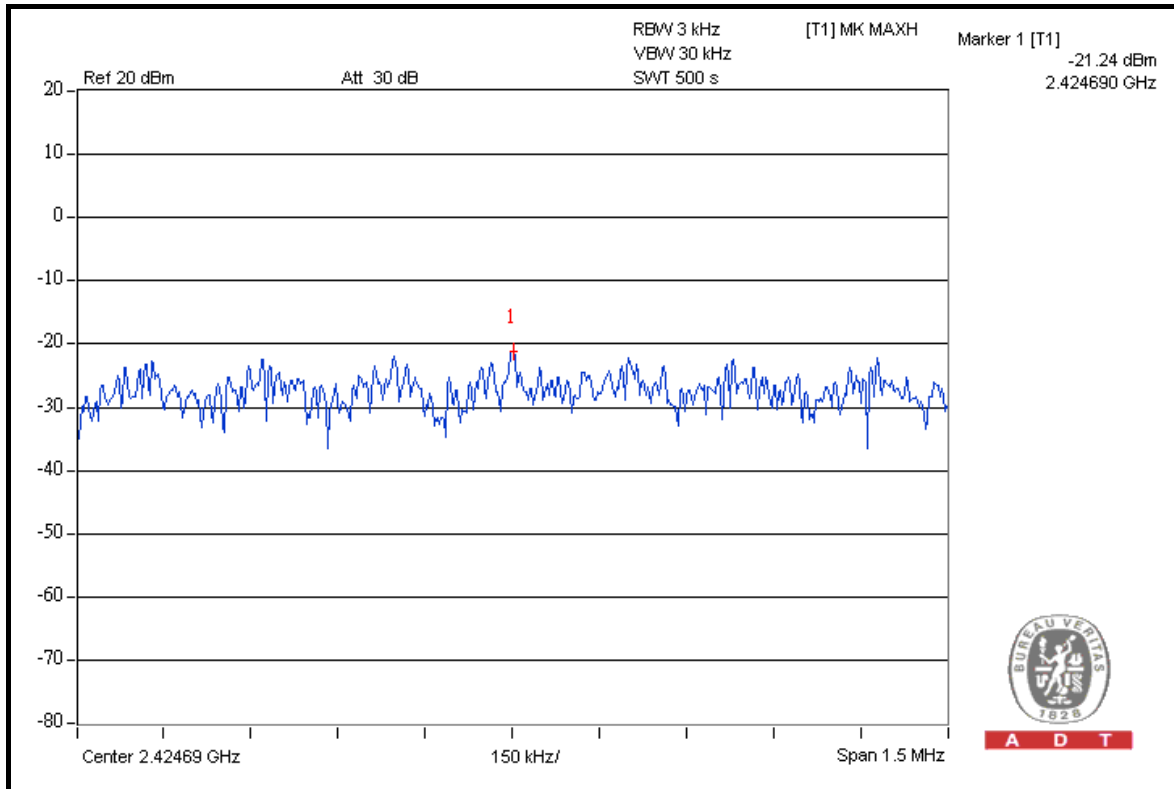



A D T

CH 7

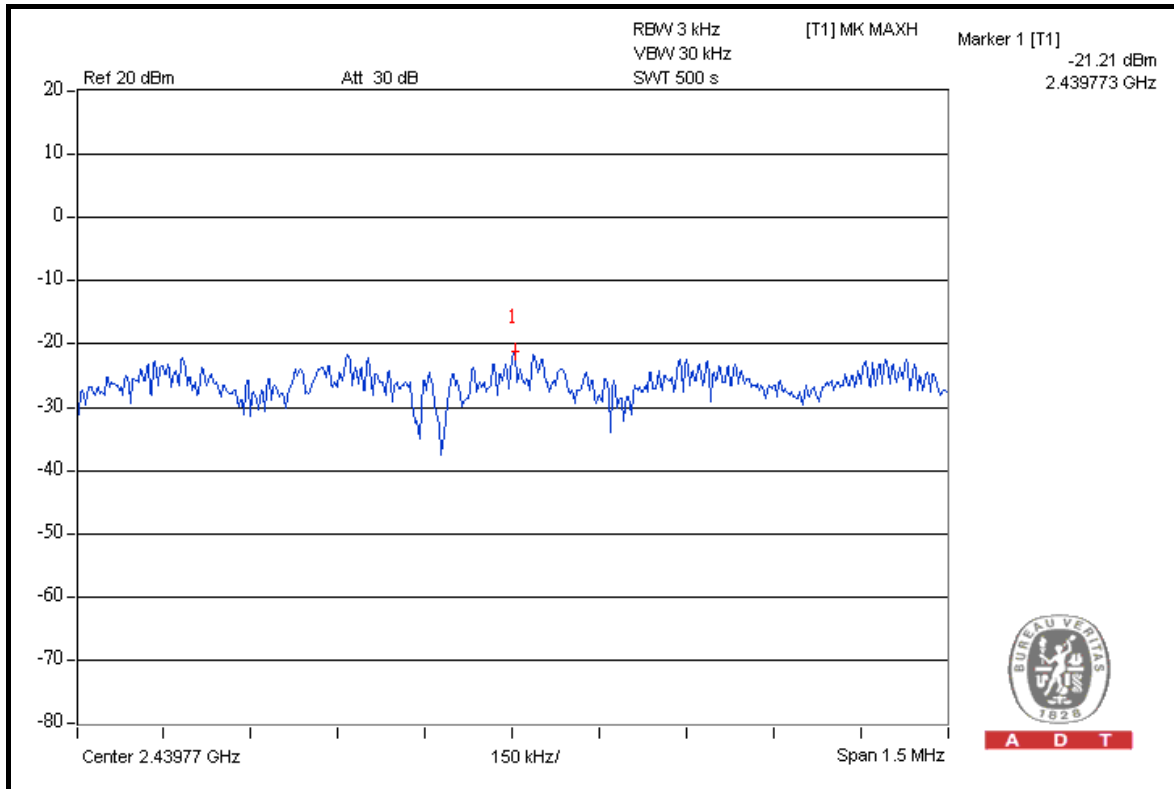

A D T

FOR CHAIN 1: CH 1

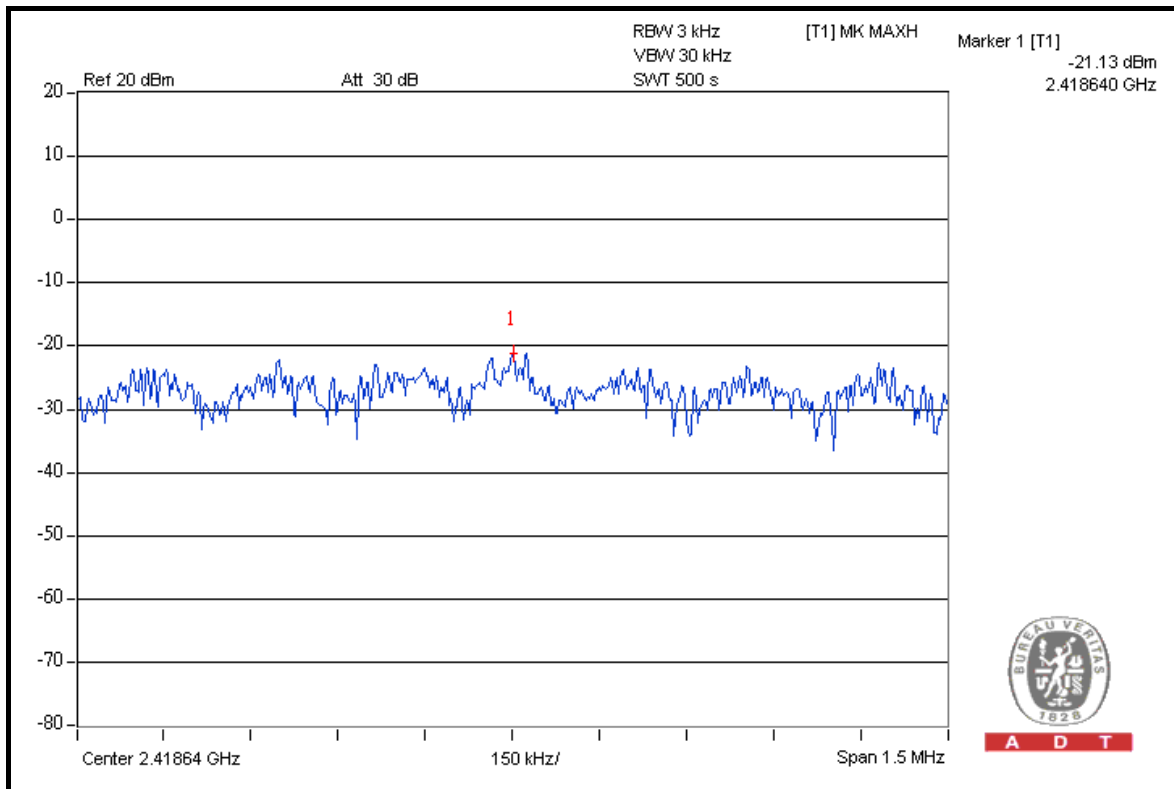

A D T



A D T

CH 4

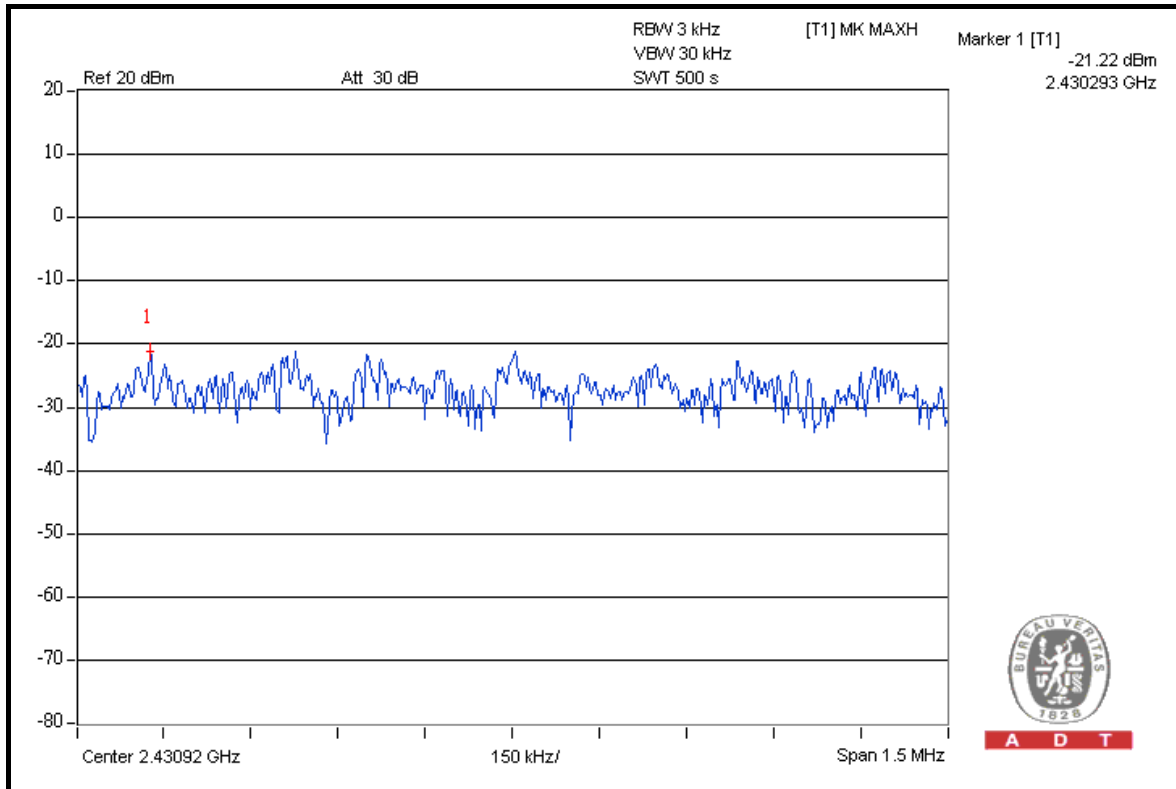

CH 7

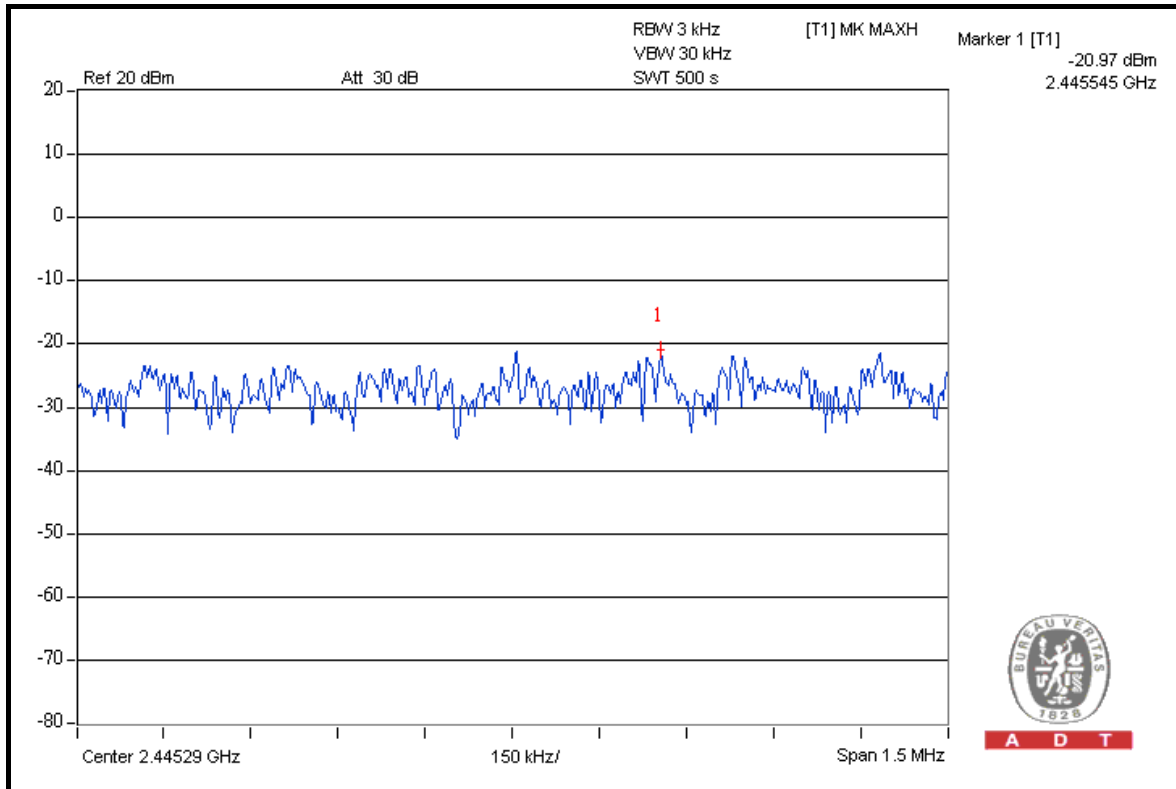



4.6 BAND EDGES MEASUREMENT

4.6.1 LIMITS OF BAND EDGES MEASUREMENT

Below -20dB of the highest emission level of operating band (in 100kHz Resolution Bandwidth).

4.6.2 TEST INSTRUMENTS

DESCRIPTION & MANUFACTURER	MODEL NO.	SERIAL NO.	DATE OF CALIBRATION	DUE DATE OF CALIBRATION
FOR CONDUCTED MEASUREMENT				
Spectrum Analyzer ROHDE & SCHWARZ	FSP40	100041	Apr. 22, 2008	Apr. 21, 2009
FOR RADIATED MEASUREMENT				
Test Receiver ROHDE & SCHWARZ	ESI7	100033	Jun. 30, 2008	Jun. 29, 2009
Spectrum Analyzer ROHDE & SCHWARZ	FSP40	100041	Apr. 22, 2008	Apr. 21, 2009
BILOG Antenna SCHWARZBECK	VULB9168	9168-160	May 02, 2008	May 01, 2009
HORN Antenna SCHWARZBECK	9120D	9120D-209	Jun. 24, 2008	Jun. 23, 2009
HORN Antenna SCHWARZBECK	BBHA 9170	BBHA9170243	Dec. 25, 2008	Dec. 24, 2009
Preamplifier Agilent	8447D	2944A10633	Nov. 03, 2008	Nov. 02, 2009
Preamplifier Agilent	8449B	3008A01964	Oct. 23, 2008	Oct. 22, 2009
RF signal cable HUBER+SUHNNER	SUCOFLEX 104	238141/4	May 20, 2008	May 19, 2009
RF signal cable HUBER+SUHNNER	SUCOFLEX 104	12738/6	May 20, 2008	May 19, 2009
Software ADT.	ADT_Radiated_ V7.6.15.9.2	NA	NA	NA
Antenna Tower inn-co GmbH	MA 4000	013303	NA	NA
Antenna Tower Controller inn-co GmbH	CO2000	017303	NA	NA
Turn Table ADT.	TT100.	TT93021703	NA	NA
Turn Table Controller ADT.	SC100.	SC93021703	NA	NA

NOTE: The calibration interval of the above test instruments is 12 months and the calibrations are traceable to NML/ROC and NIST/USA.



A D T

4.6.3 TEST PROCEDURE

FOR CONDUCTED MEASUREMENT

The transmitter output was connected to the spectrum analyzer via a low loss cable. Set both RBW and VBW of spectrum analyzer to 100kHz and 300kHz with suitable frequency span including 100MHz bandwidth from band edge. The band edges was measured and recorded.

The spectrum plots (Peak RBW = 100kHz, VBW = 300kHz; Average RBW = 1MHz, VBW = 10Hz) are attached on the following pages.

FOR RADIATED MEASUREMENT

- a. The EUT was placed on the top of a rotating table 0.8 meters above the ground at a 3 meter semi-anechoic chamber. The table was rotated 360 degrees to determine the position of the highest radiation.
- b. The EUT was set 3 meters away from the interference-receiving antenna, which was mounted on the top of a variable-height antenna tower.
- c. The antenna is a broadband antenna, and its height is varied from one meter to four meters above the ground to determine the maximum value of the field strength. Both horizontal and vertical polarizations of the antenna are set to make the measurement.
- d. For each suspected emission, the EUT was arranged to its worst case and then the antenna was tuned to heights from 1 meter to 4 meters and the rotatable table was turned from 0 degrees to 360 degrees to find the maximum reading.
- e. Set both RBW and VBW of spectrum analyzer to 100kHz and 300kHz with suitable frequency span including 100MHz bandwidth from band edge. The band edges was measured and recorded.

The spectrum plots (Peak RBW = 100kHz, VBW = 300kHz) are attached on the following pages.

NOTE: The resolution bandwidth of test receiver/spectrum analyzer is 1MHz and the video bandwidth is 10Hz for Average detection (AV) at frequency above 1GHz.



A D T

4.6.4 DEVIATION FROM TEST STANDARD

No deviation.

4.6.5 EUT OPERATING CONDITION

Same as Item 4.3.6.

4.6.6 TEST RESULTS

The spectrum plots are attached on the following pages. D1 line indicates the highest level, and D2 line indicates the 20dB offset below D1. It shows compliance with the requirement in part 15.247(d).

802.11b DSSS MODULATION

NOTE 1: The band edge emission plot on the next page shows 47.67dBc between carrier maximum power and local maximum emission in restrict band (2.3746GHz). The emission of carrier strength list in the test result of channel 1 at the item 4.1.7 is 105.80dBuV/m (Peak), so the maximum field strength in restrict band is $105.80 - 47.67 = 58.13$ dBuV/m which is under 74dBuV/m limit.

The band edge emission plot of on the next page shows 56.86dBc between carrier maximum power and local maximum emission in restrict band (2.3866GHz). The emission of carrier strength list in the test result of channel 1 at the item 4.1.7 is 101.40dBuV/m (Average), so the maximum field strength in restrict band is $101.40 - 56.86 = 44.54$ dBuV/m which is under 54dBuV/m limit.

NOTE 2: The band edge emission plot on the next second page shows 48.48dBc between carrier maximum power and local maximum emission in restrict band (2.4890GHz). The emission of carrier strength list in the test result of channel 11 at the item 4.1.7 is 105.92dBuV/m (Peak), so the maximum field strength in restrict band is $105.92 - 48.48 = 57.44$ dBuV/m which is under 74dBuV/m limit.

The band edge emission plot on the next third page shows 57.85dBc between carrier maximum power and local maximum emission in restrict band (2.4876GHz). The emission of carrier strength list in the test result of channel 11 at the item 4.1.7 is 101.53dBuV/m (Average), so the maximum field strength in restrict band is $101.53 - 57.85 = 43.68$ dBuV/m which is under 54dBuV/m limit.



A D T

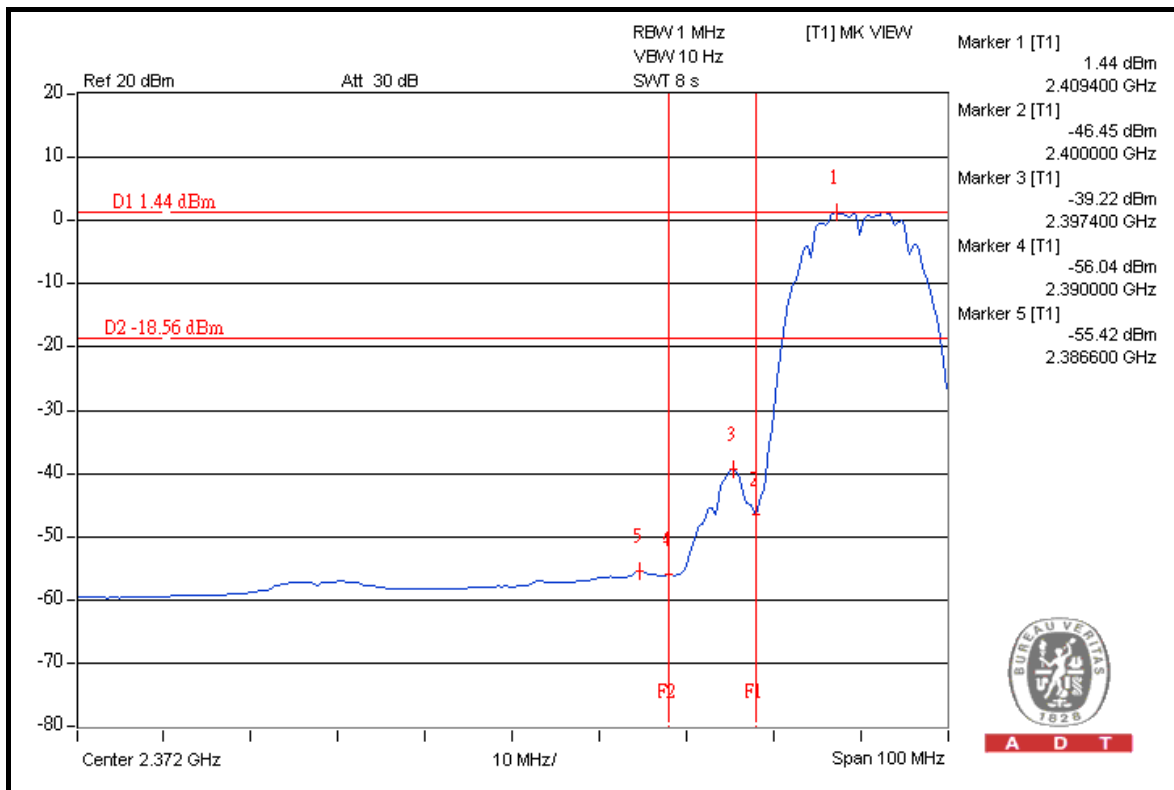
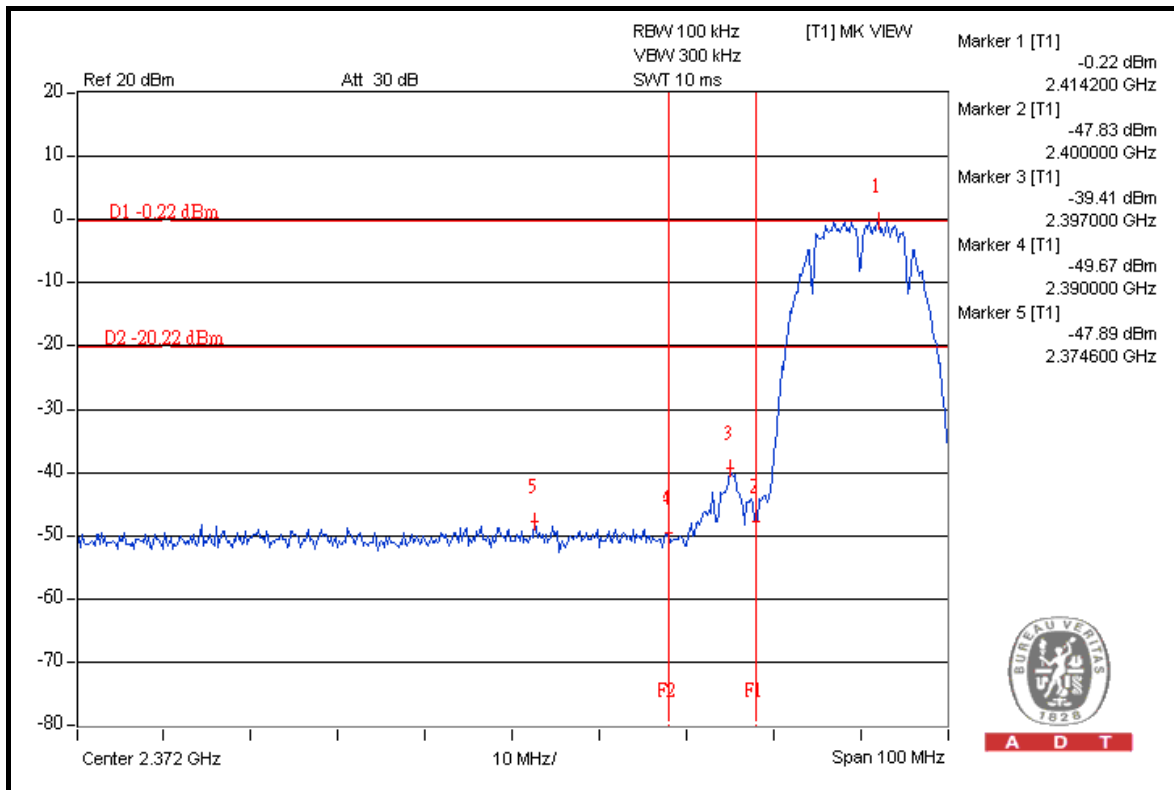



A D T

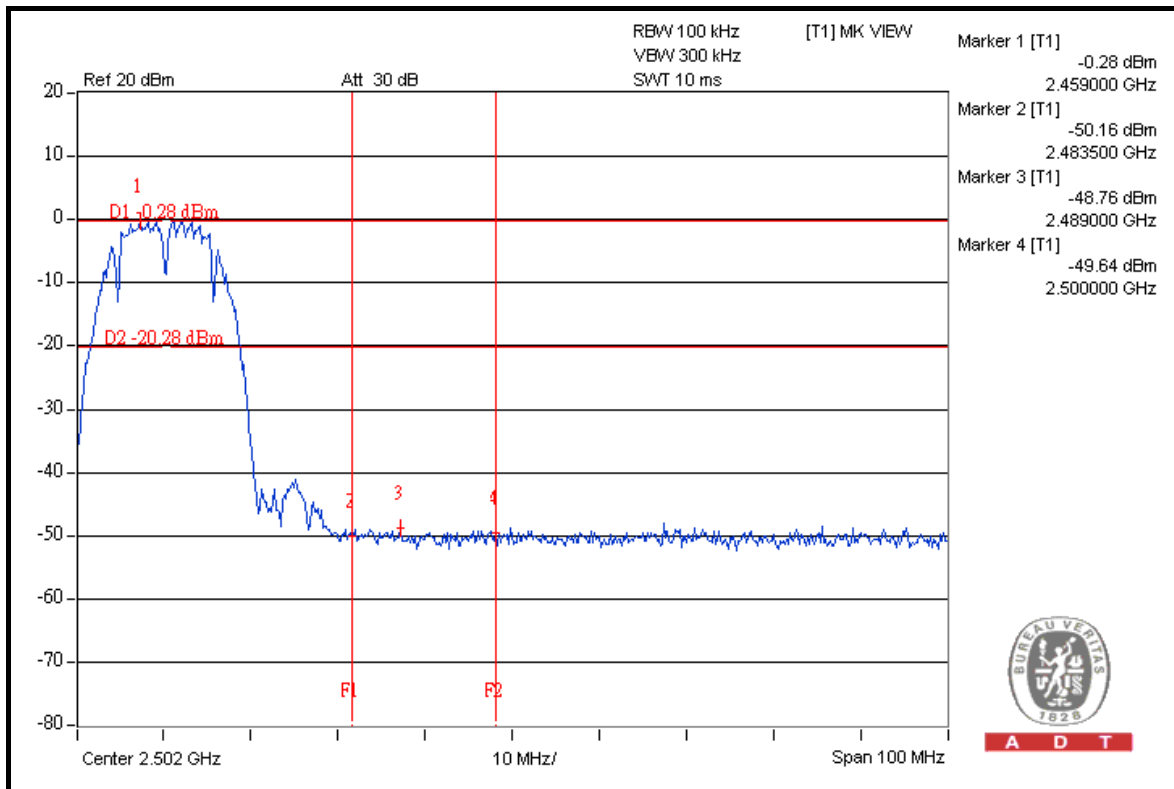
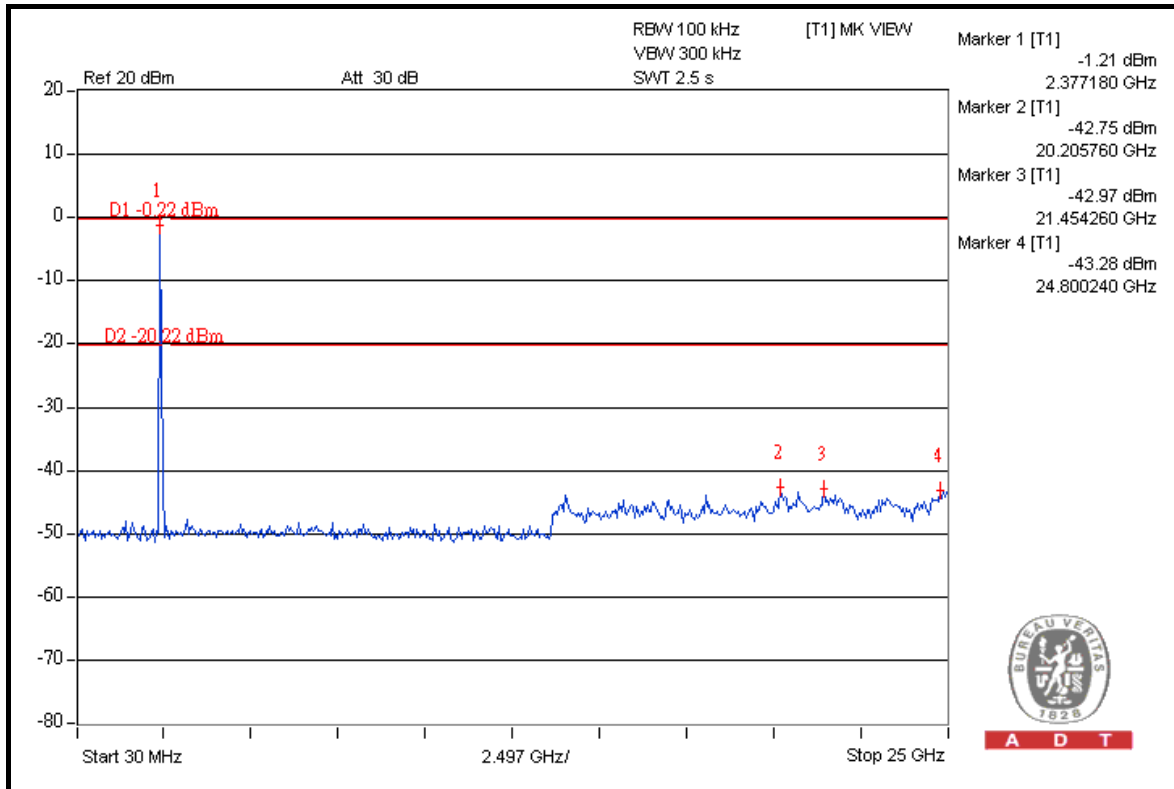



A D T

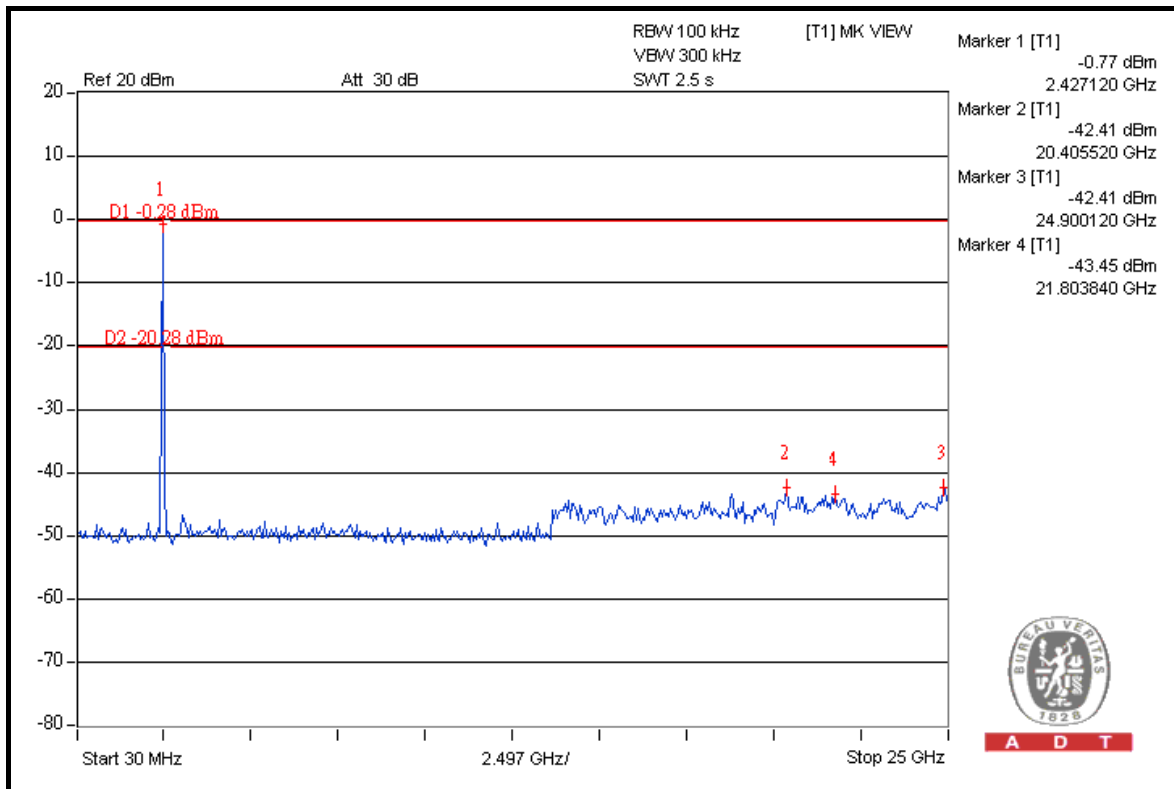
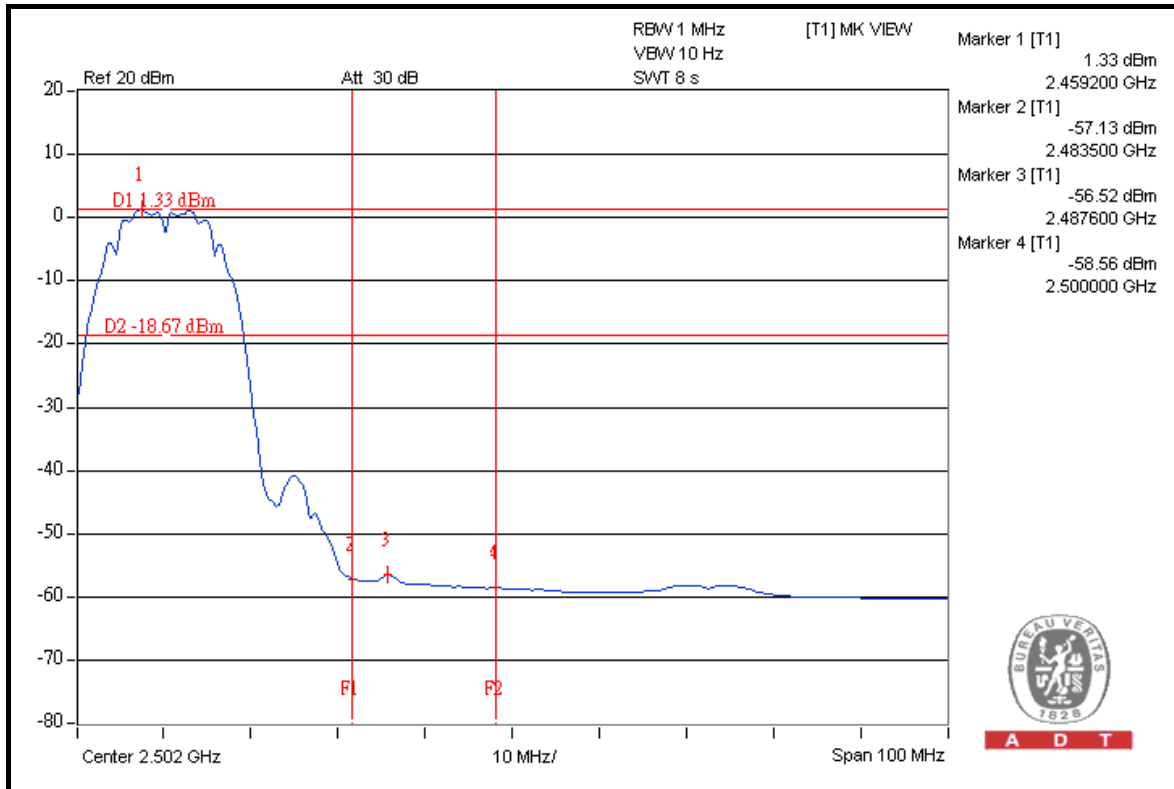



802.11g OFDM MODULATION

NOTE 1: The band edge emission plot on the next page shows 44.33dBc between carrier maximum power and local maximum emission in restrict band (2.3896GHz). The emission of carrier strength list in the test result of channel 1 at the item 4.1.7 is 110.44dBuV/m (Peak), so the maximum field strength in restrict band is $110.44 - 44.33 = 66.11$ dBuV/m which is under 74dBuV/m limit.

The band edge emission plot of on the next page shows 49.69dBc between carrier maximum power and local maximum emission in restrict band (2.3900GHz). The emission of carrier strength list in the test result of channel 1 at the item 4.1.7 is 100.60dBuV/m (Average), so the maximum field strength in restrict band is $100.60 - 49.69 = 50.91$ dBuV/m which is under 54dBuV/m limit.

NOTE 2: The band edge emission plot on the next second page shows 45.55dBc between carrier maximum power and local maximum emission in restrict band (2.4874GHz). The emission of carrier strength list in the test result of channel 11 at the item 4.1.7 is 110.68dBuV/m (Peak), so the maximum field strength in restrict band is $110.68 - 45.55 = 65.13$ dBuV/m which is under 74dBuV/m limit.

The band edge emission plot on the next third page shows 51.50dBc between carrier maximum power and local maximum emission in restrict band (2.4835GHz). The emission of carrier strength list in the test result of channel 11 at the item 4.1.7 is 100.85dBuV/m (Average), so the maximum field strength in restrict band is $100.85 - 51.50 = 49.35$ dBuV/m which is under 54dBuV/m limit.



A D T

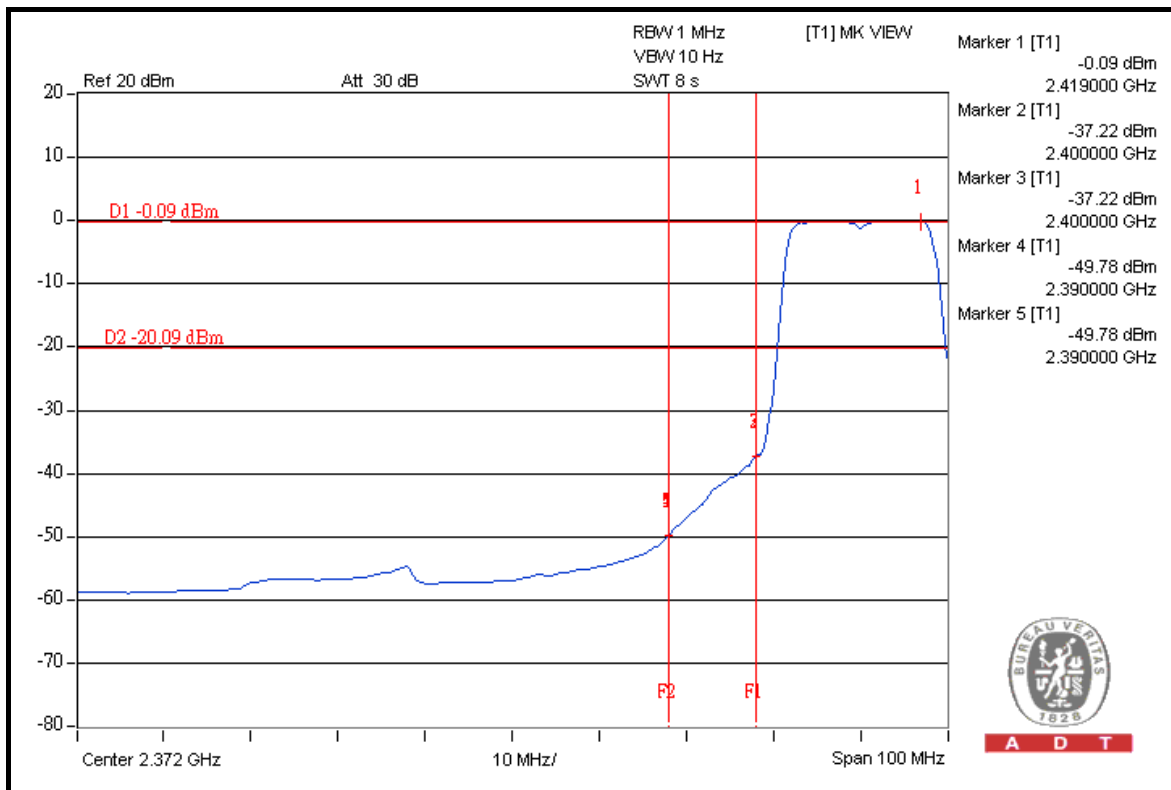
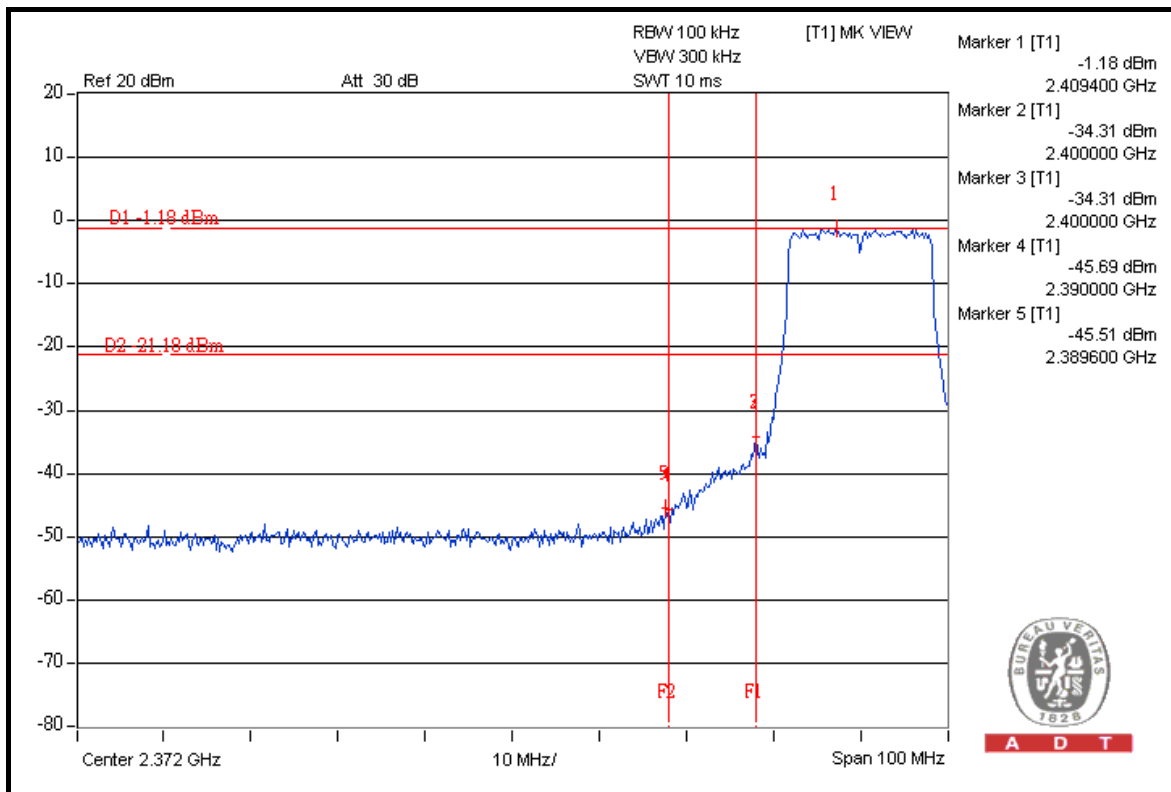



A D T

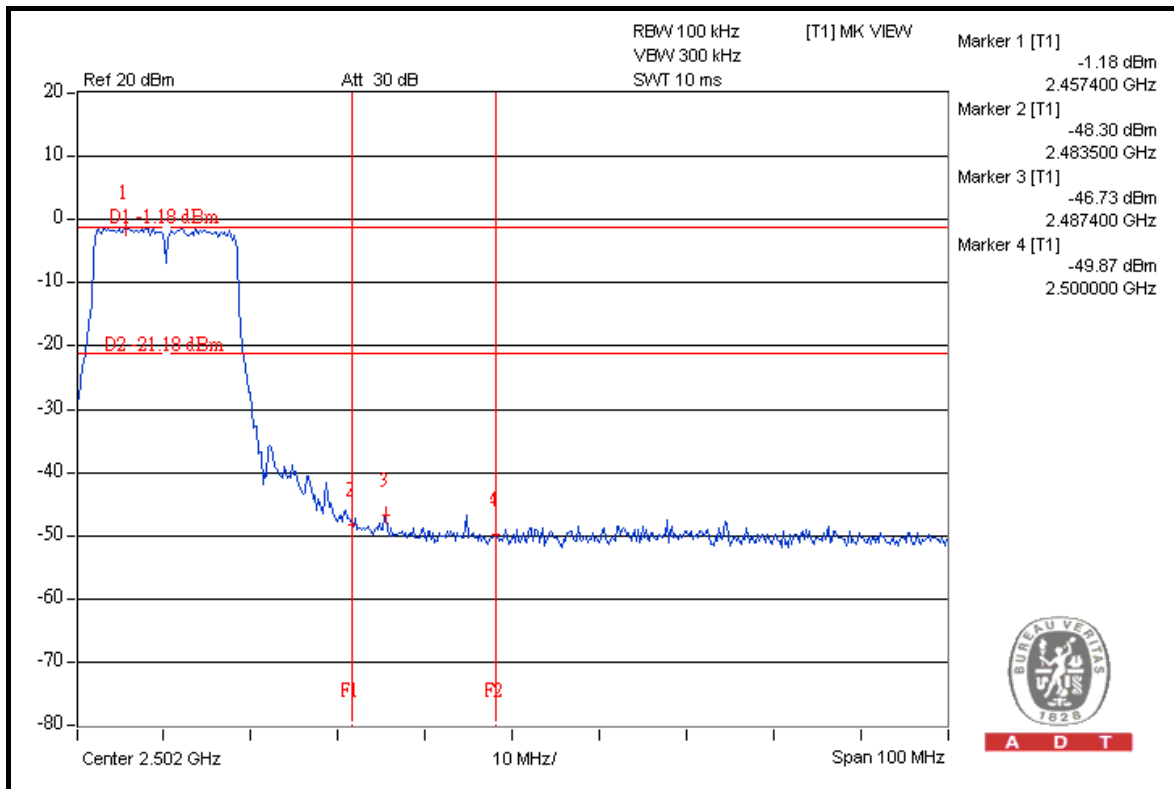
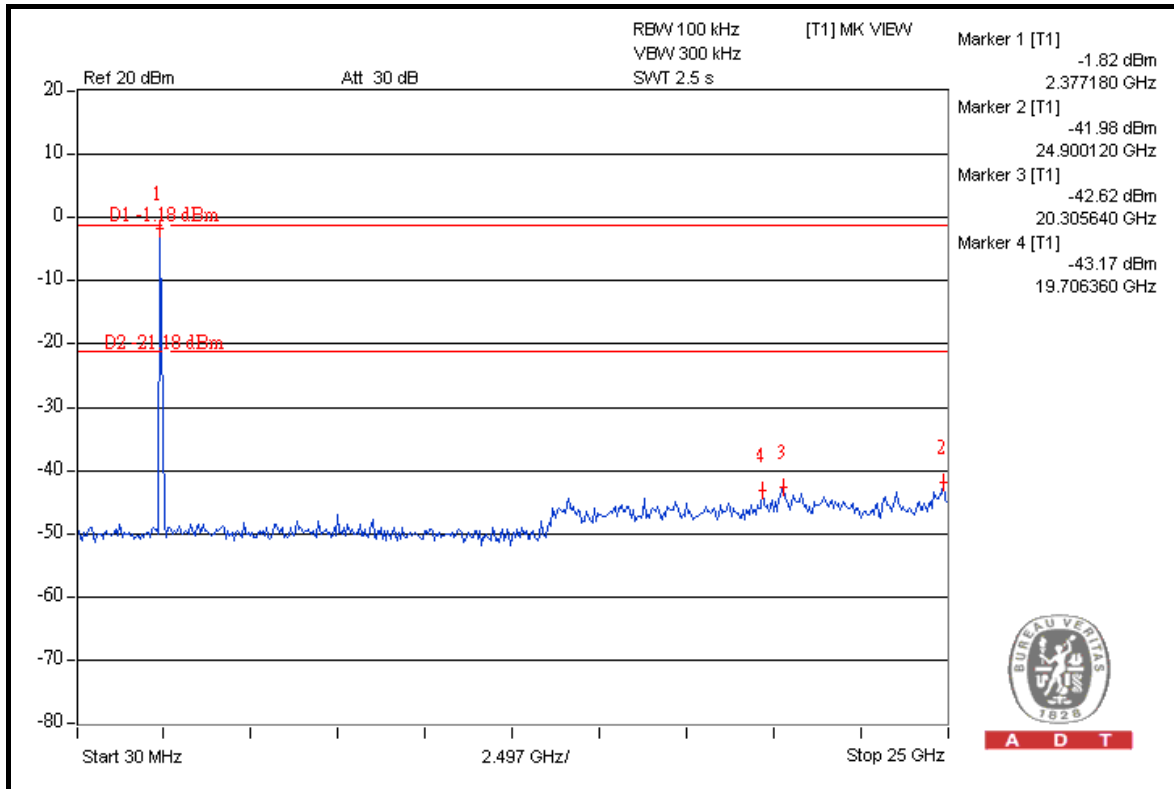



A D T

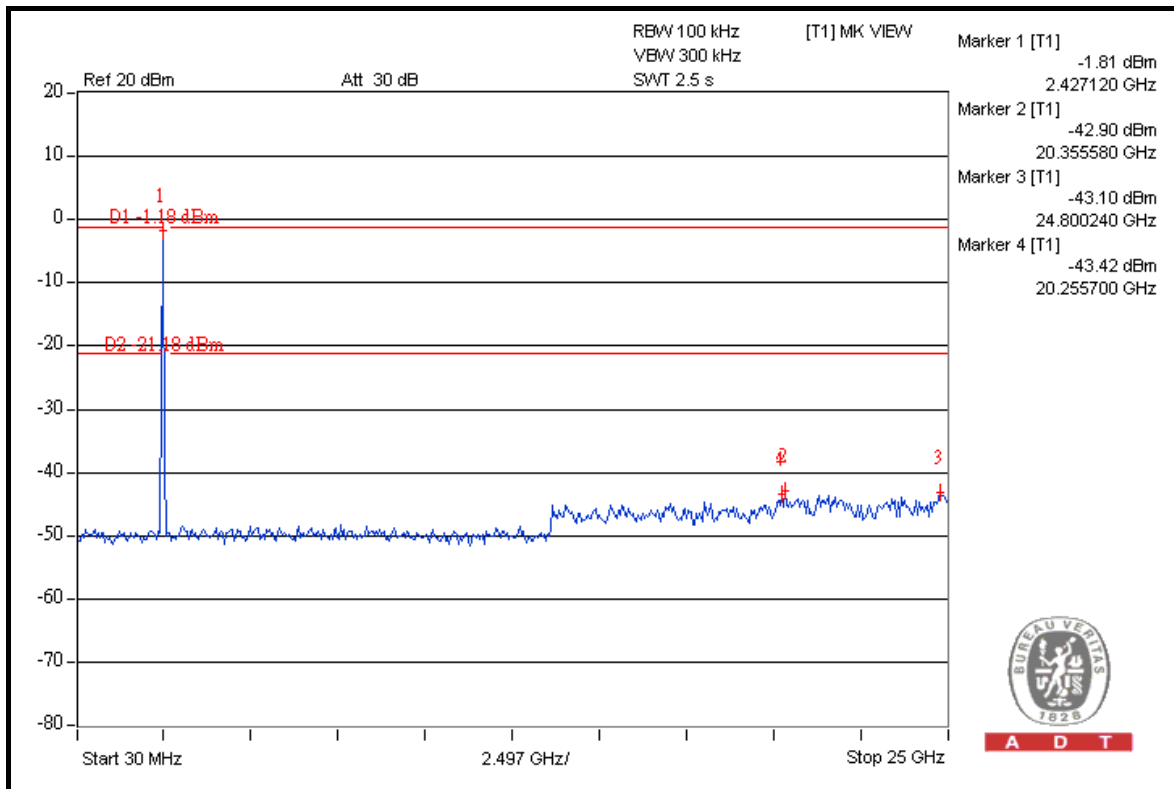
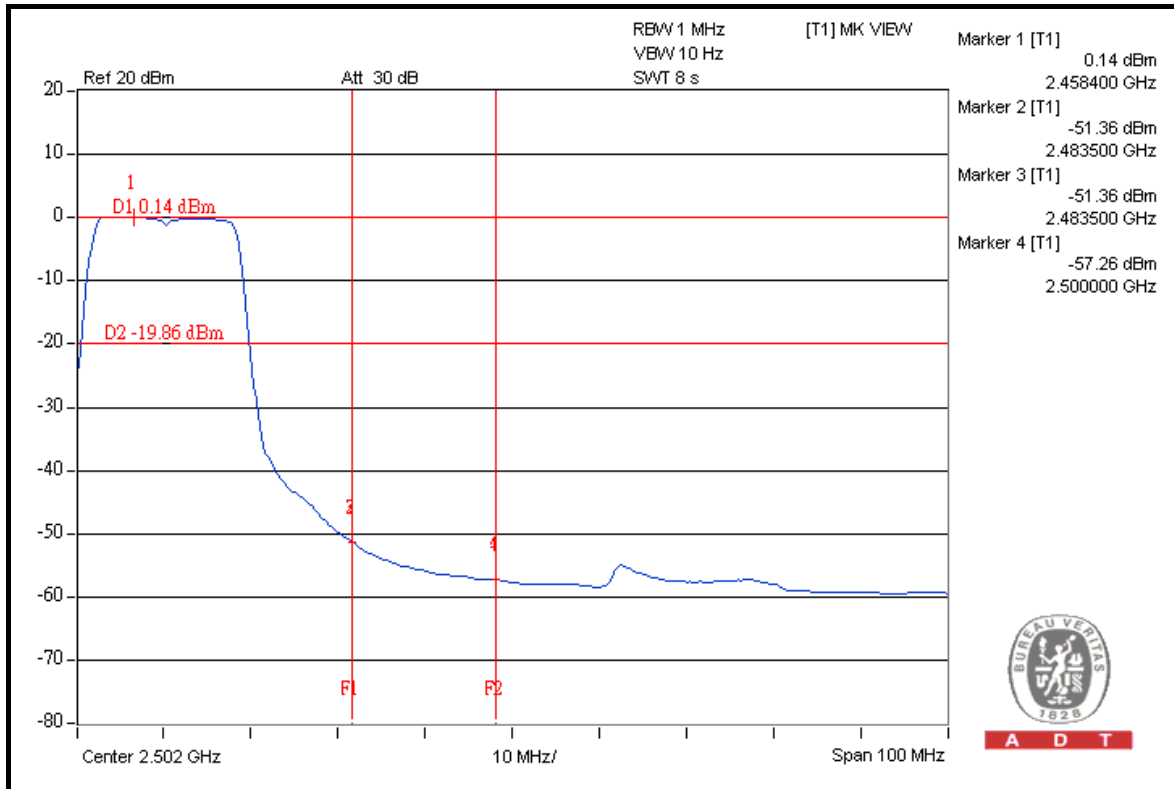



DRAFT 802.11n (20MHz) OFDM MODULATION

NOTE 1: The band edge emission plot on the next page shows 46.43dBc between carrier maximum power and local maximum emission in restrict band (2.3362GHz). The emission of carrier strength list in the test result of channel 1 at the item 4.1.7 is 110.79dBuV/m (Peak), so the maximum field strength in restrict band is $110.79 - 46.43 = 64.36$ dBuV/m which is under 74dBuV/m limit.

The band edge emission plot of on the next page shows 50.34dBc between carrier maximum power and local maximum emission in restrict band (2.3900GHz). The emission of carrier strength list in the test result of channel 1 at the item 4.1.7 is 100.40dBuV/m (Average), so the maximum field strength in restrict band is $100.40 - 50.34 = 50.06$ dBuV/m which is under 54dBuV/m limit.

NOTE 2: The band edge emission plot on the next second page shows 46.51dBc between carrier maximum power and local maximum emission in restrict band (2.4838GHz). The emission of carrier strength list in the test result of channel 11 at the item 4.1.7 is 110.99dBuV/m (Peak), so the maximum field strength in restrict band is $110.99 - 46.51 = 64.48$ dBuV/m which is under 74dBuV/m limit.

The band edge emission plot on the next third page shows 49.37dBc between carrier maximum power and local maximum emission in restrict band (2.4835GHz). The emission of carrier strength list in the test result of channel 11 at the item 4.1.7 is 100.65dBuV/m (Average), so the maximum field strength in restrict band is $100.65 - 49.37 = 51.28$ dBuV/m which is under 54dBuV/m limit.



A D T

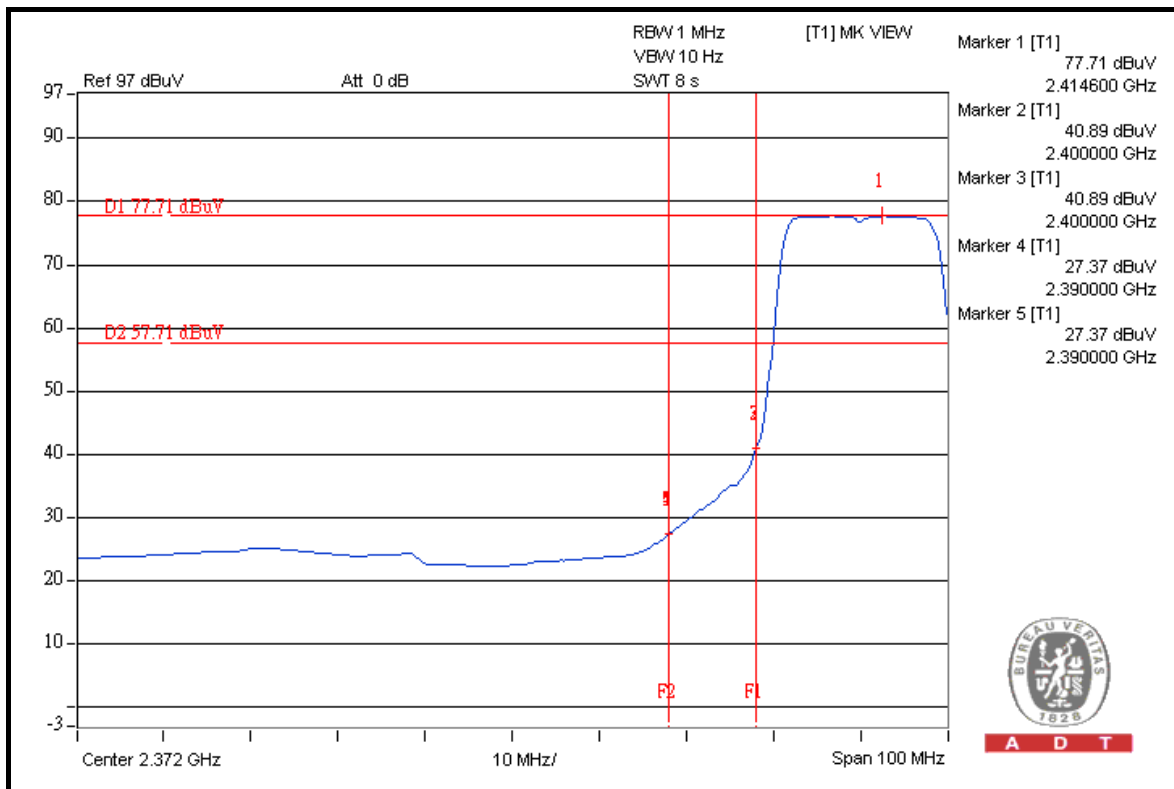
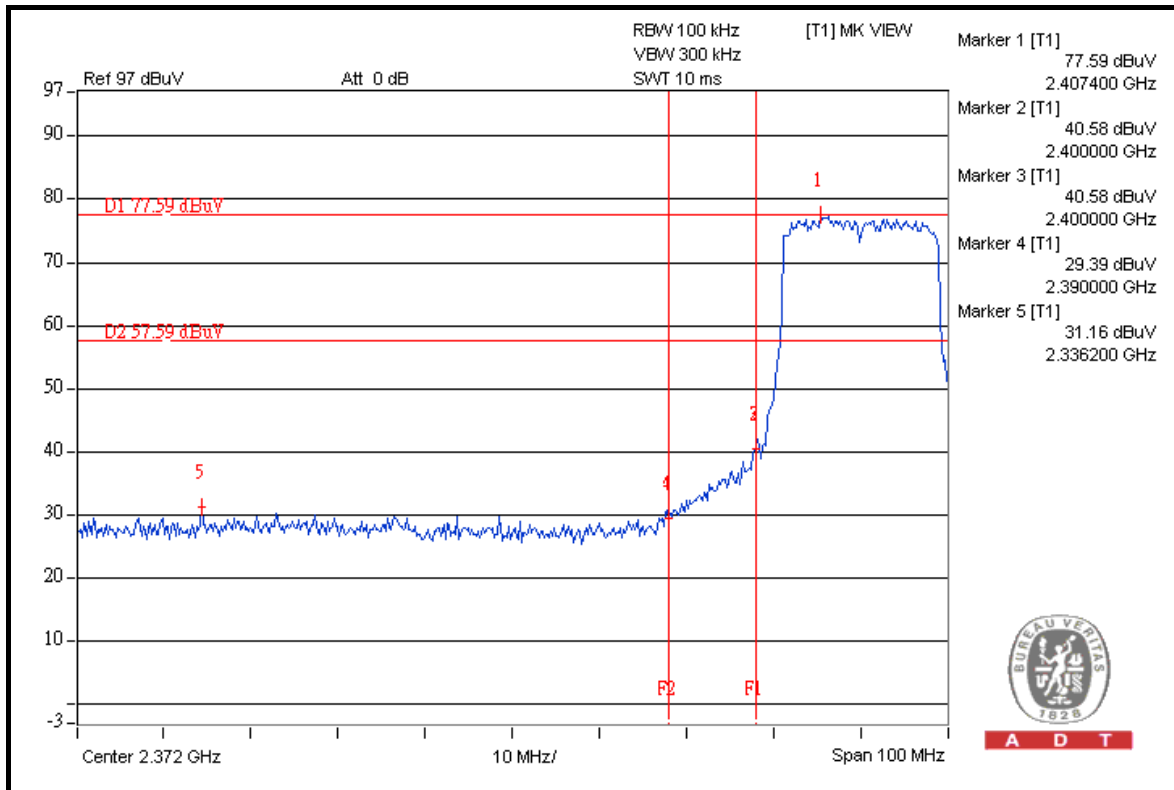



A D T

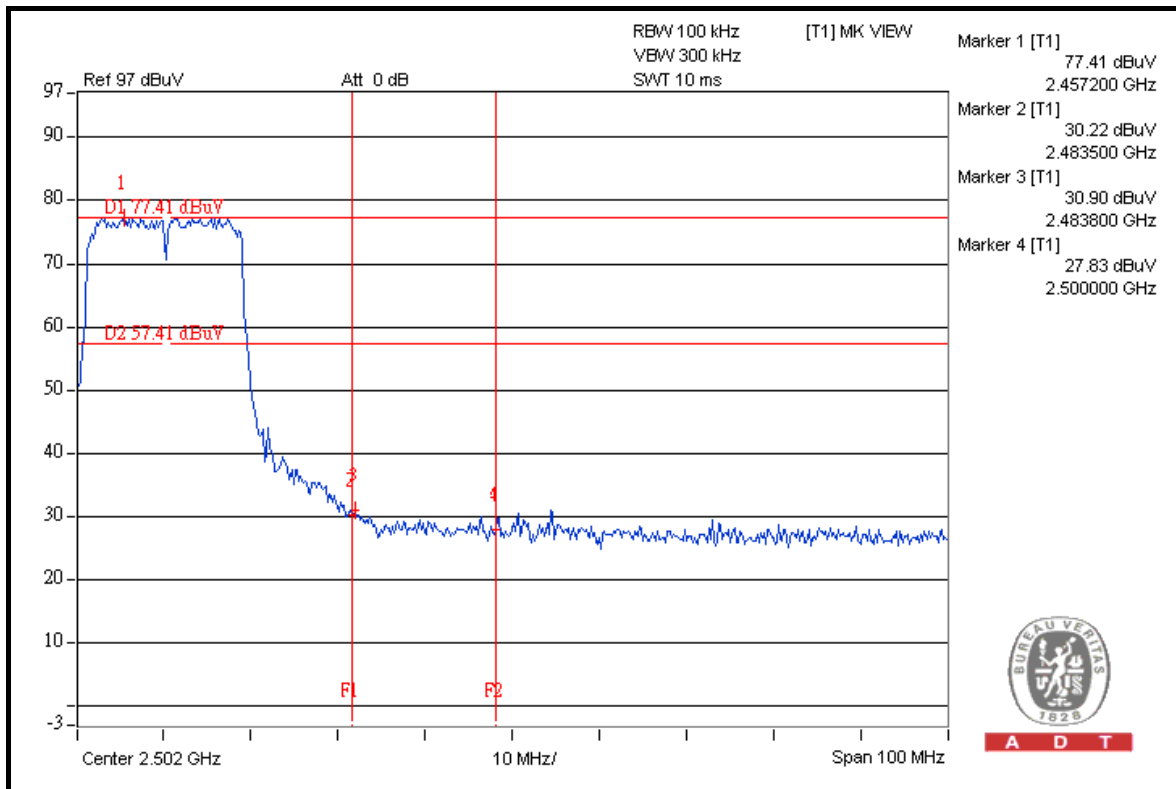
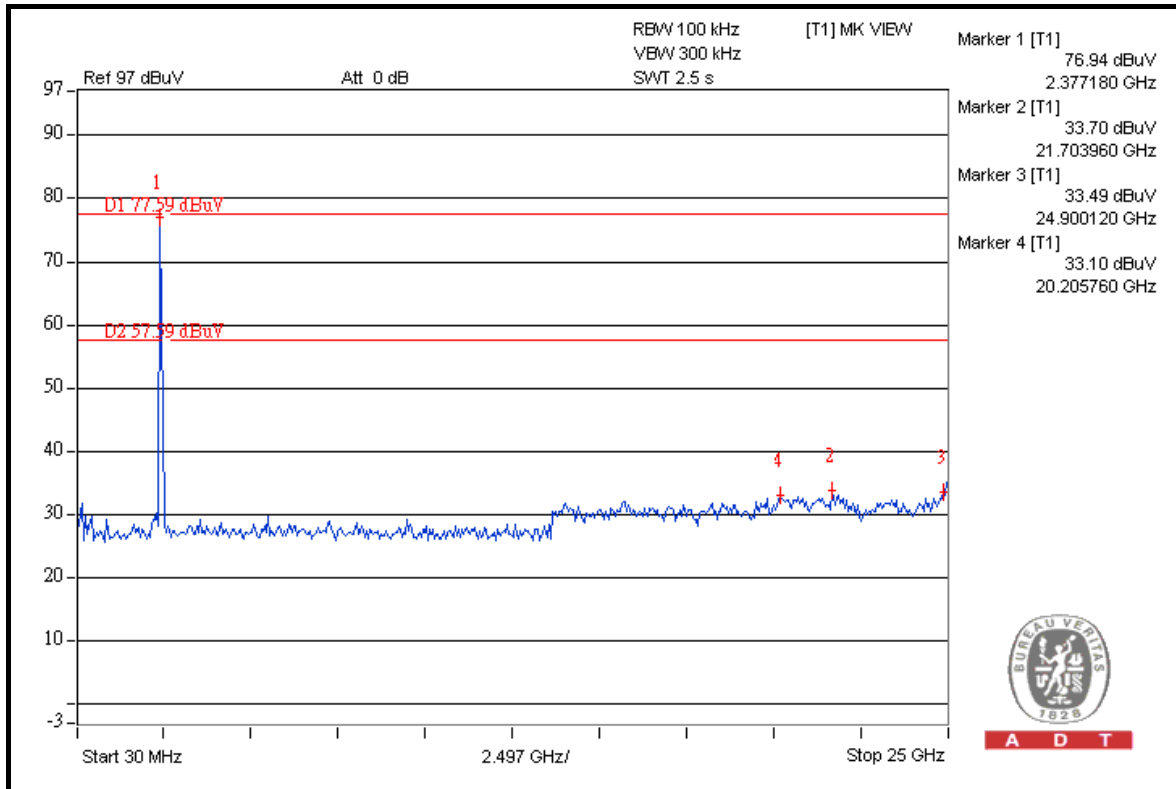



A D T

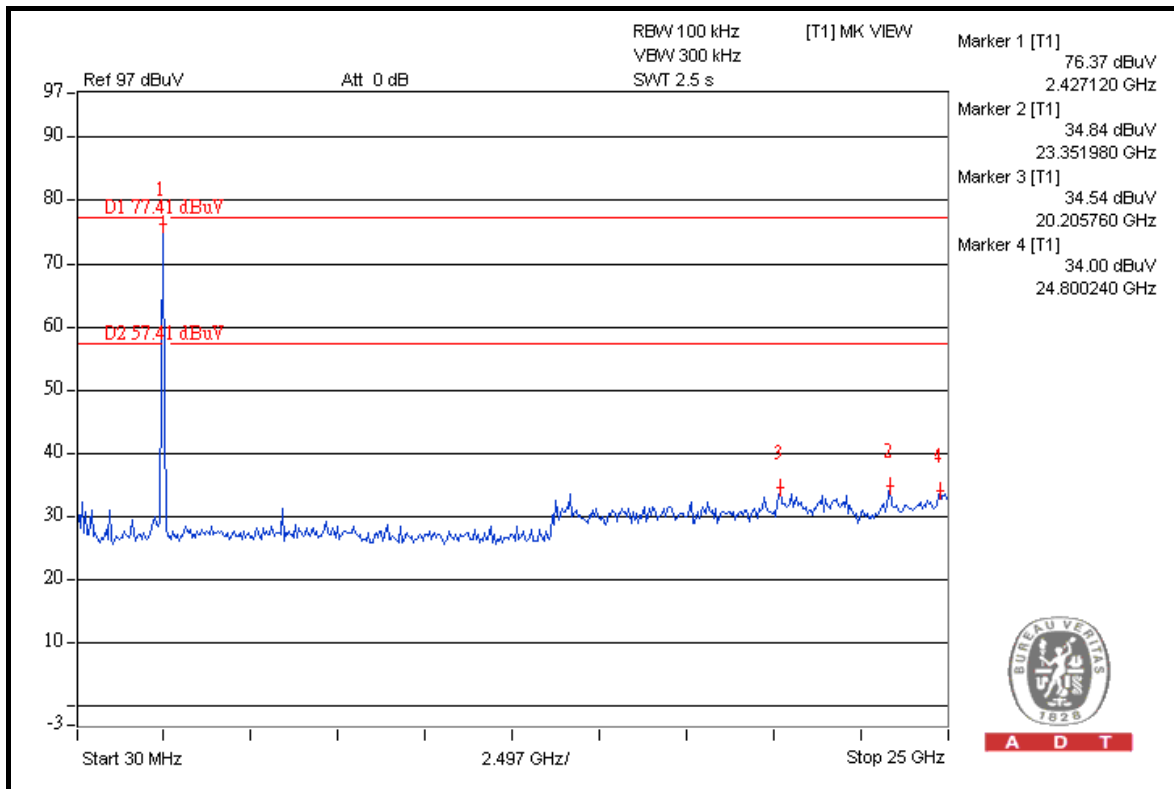
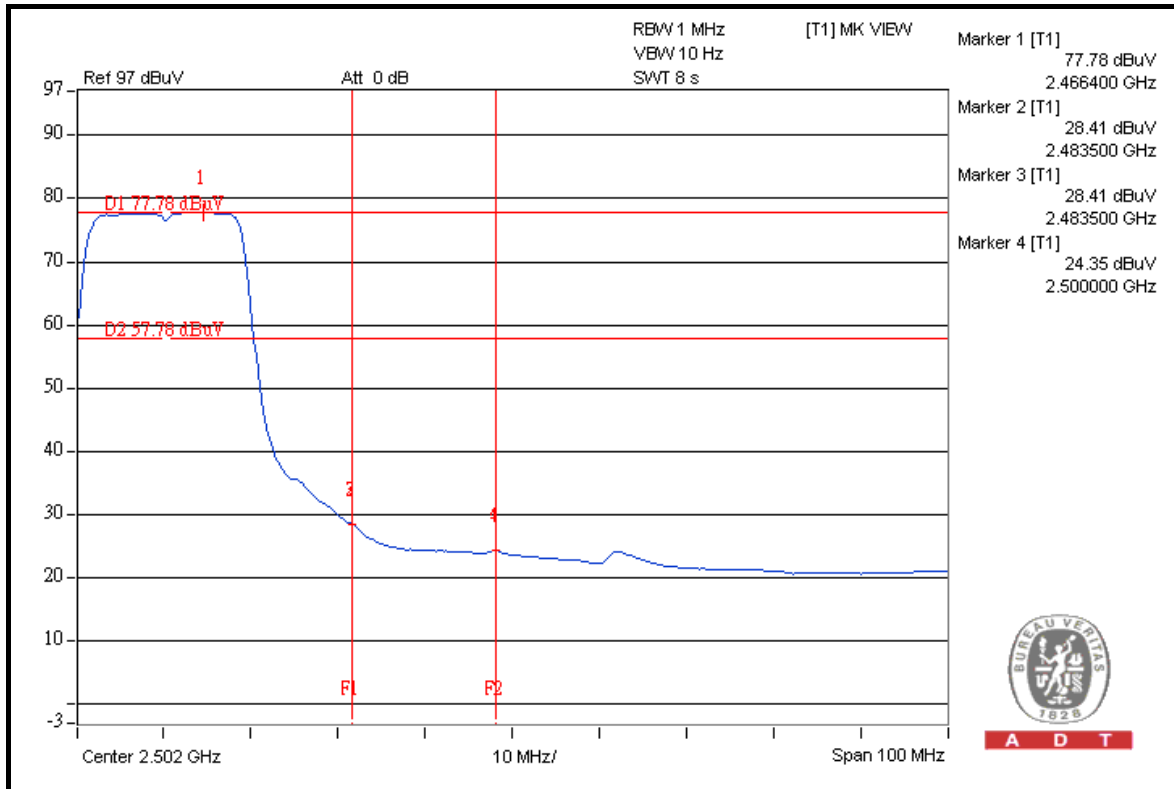



DRAFT 802.11n (40MHz) OFDM MODULATION

NOTE 1: The band edge emission plot on the next page shows 43.08dBc between carrier maximum power and local maximum emission in restrict band (2.3848GHz). The emission of carrier strength list in the test result of channel 1 at the item 4.1.7 is 107.76dBuV/m (Peak), so the maximum field strength in restrict band is $107.76 - 43.08 = 64.68$ dBuV/m which is under 74dBuV/m limit.

The band edge emission plot of on the next page shows 46.99dBc between carrier maximum power and local maximum emission in restrict band (2.3884GHz). The emission of carrier strength list in the test result of channel 1 at the item 4.1.7 is 97.45dBuV/m (Average), so the maximum field strength in restrict band is $97.45 - 46.99 = 50.46$ dBuV/m which is under 54dBuV/m limit.

NOTE 2: The band edge emission plot on the next second page shows 44.77dBc between carrier maximum power and local maximum emission in restrict band (2.4888GHz). The emission of carrier strength list in the test result of channel 7 at the item 4.1.7 is 107.56dBuV/m (Peak), so the maximum field strength in restrict band is $107.56 - 44.77 = 62.79$ dBuV/m which is under 74dBuV/m limit.

The band edge emission plot on the next third page shows 48.89dBc between carrier maximum power and local maximum emission in restrict band (2.4880GHz). The emission of carrier strength list in the test result of channel 7 at the item 4.1.7 is 97.34dBuV/m (Average), so the maximum field strength in restrict band is $97.34 - 48.89 = 48.45$ dBuV/m which is under 54dBuV/m limit.



A D T

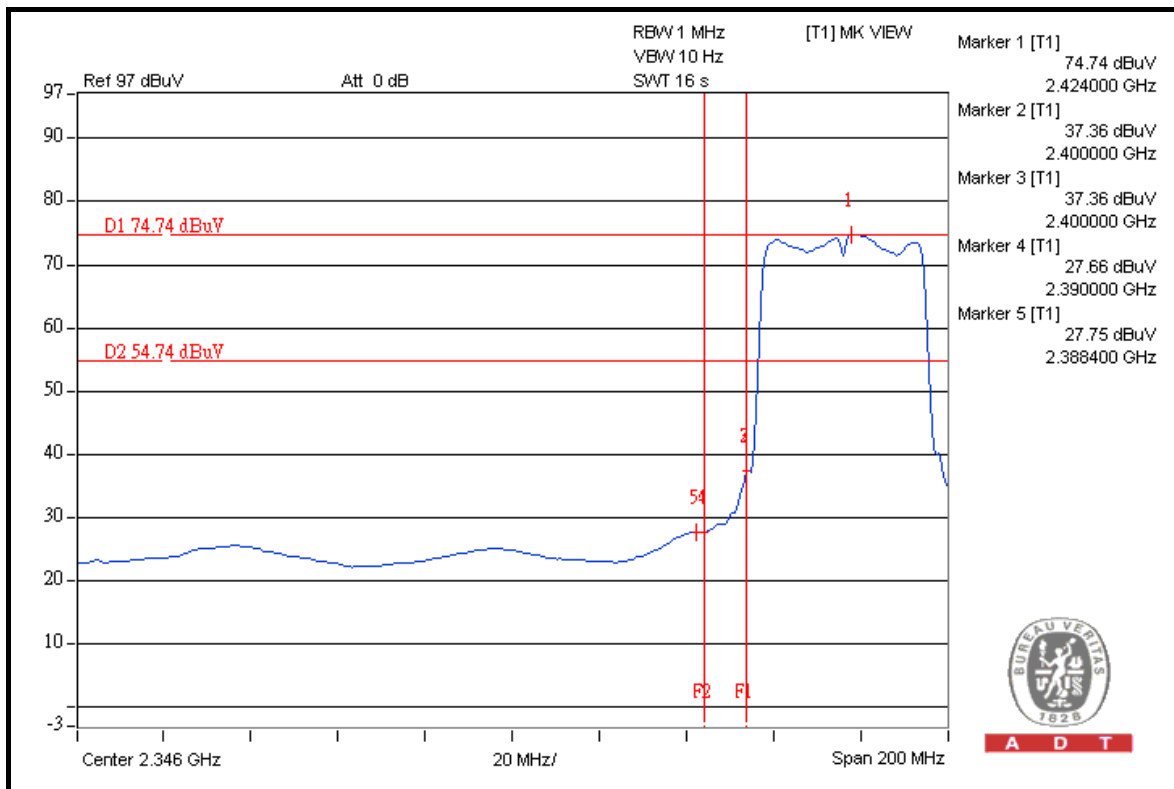
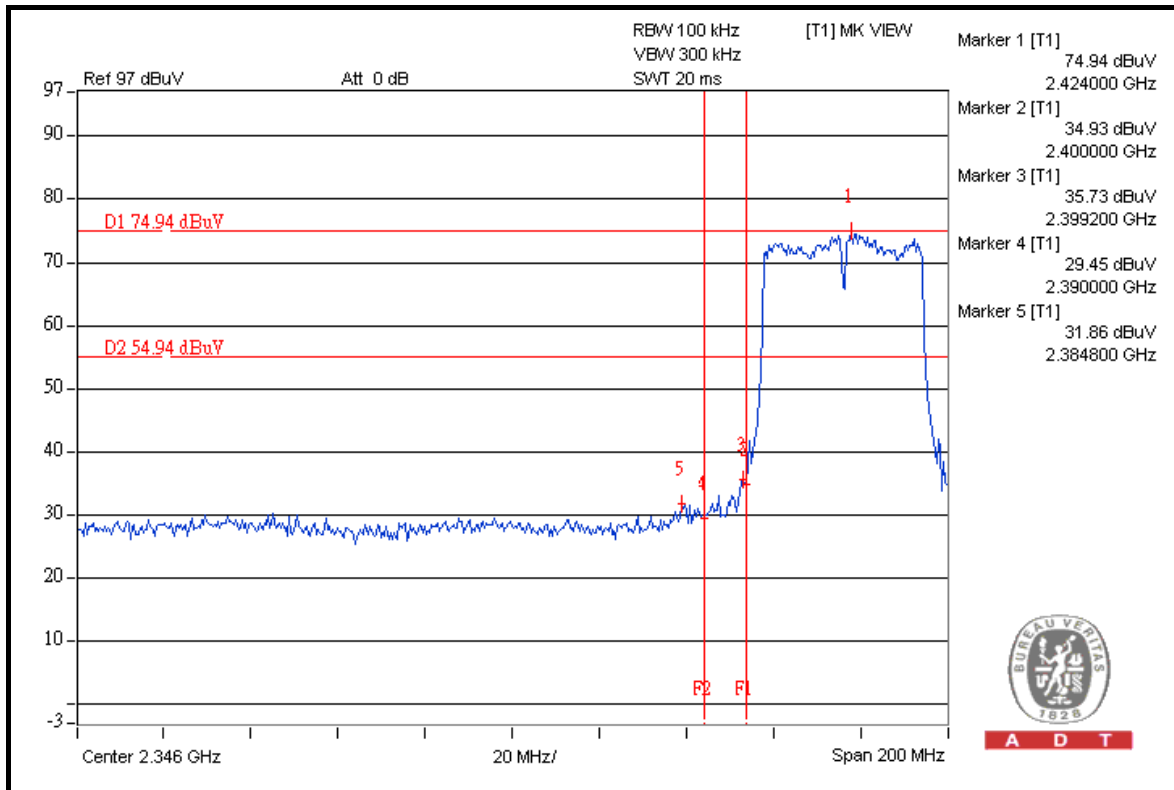



A D T

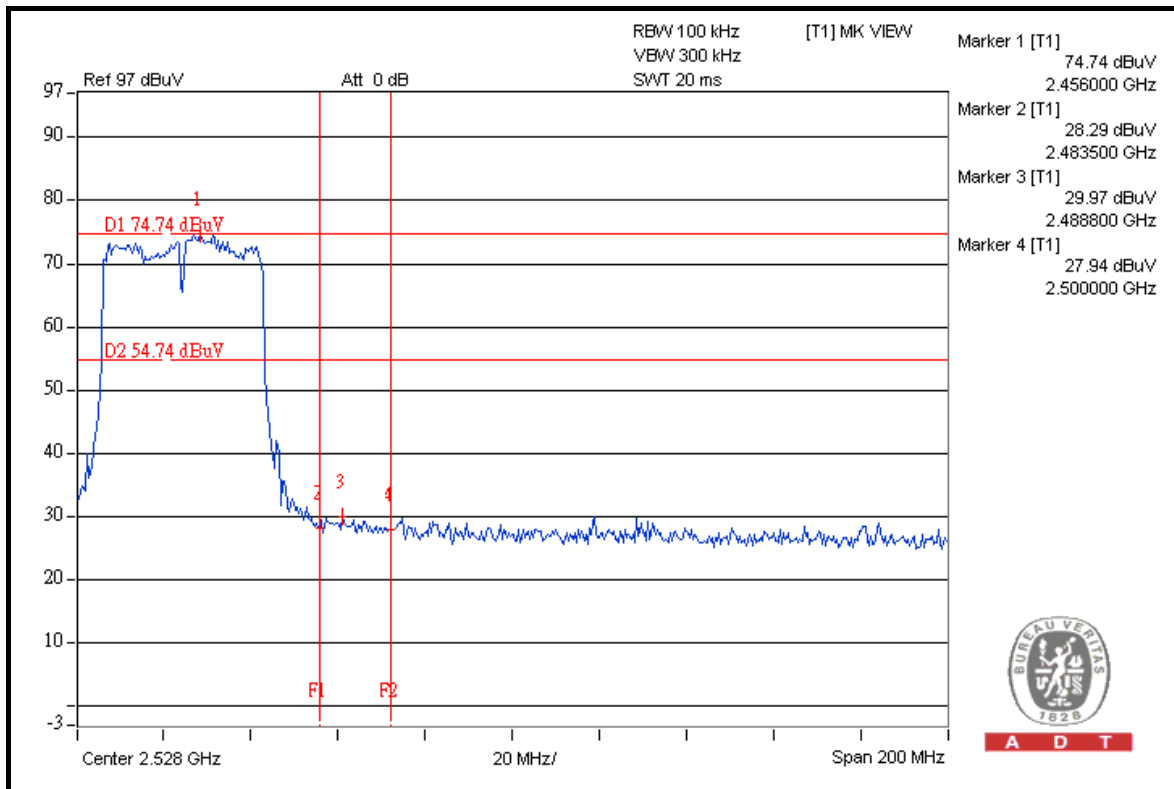
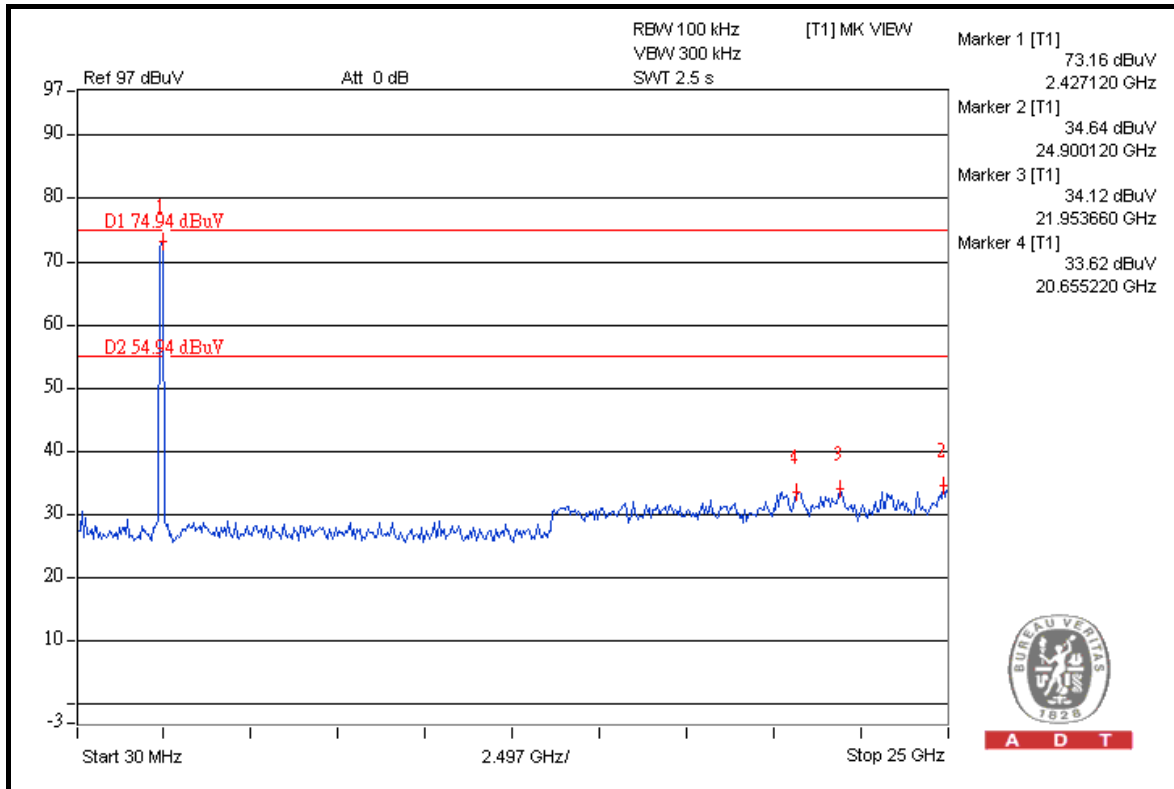



A D T

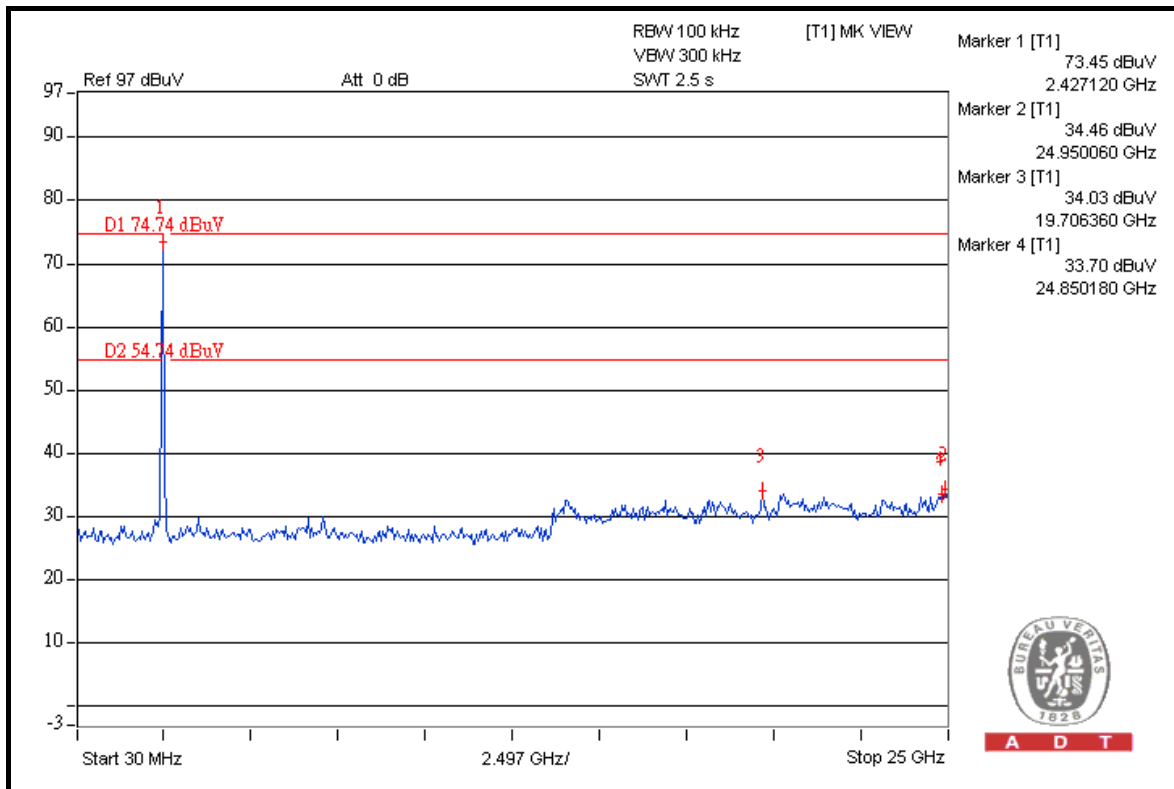
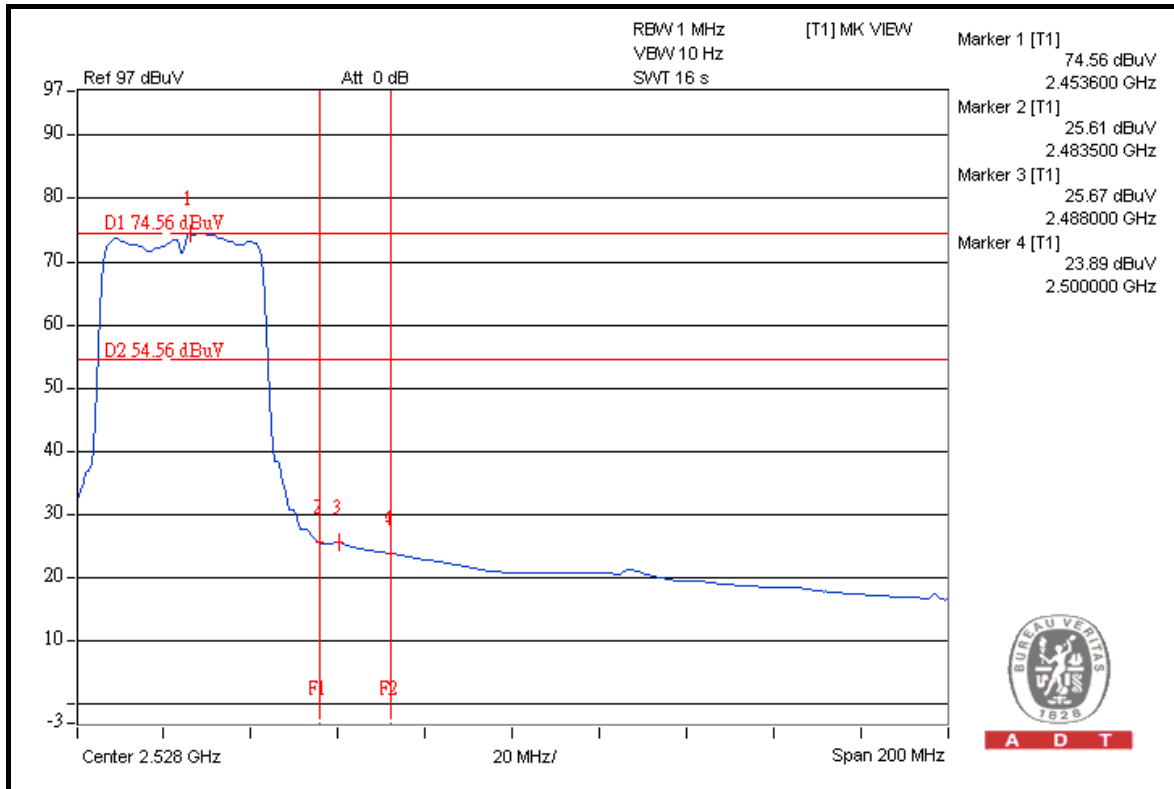



A D T

4.7 ANTENNA REQUIREMENT

4.7.1 STANDARD APPLICABLE

For intentional device, according to FCC 47 CFR Section 15.203, an intentional radiator shall be designed to ensure that no antenna other than that furnished by the responsible party shall be used with the device.

And according to FCC 47 CFR Section 15.247 (b), if transmitting antennas of directional gain greater than 6dBi are used, the power shall be reduced by the amount in dB that the directional gain of the antenna exceeds 6dBi.

4.7.2 ANTENNA CONNECTED CONSTRUCTION

The antenna used in this product is Dipole antenna with RTNC connector. The maximum gain of the antenna is 5dBi.



A D T

5. PHOTOGRAPHS OF THE TEST CONFIGURATION

Please refer to the attached file (Test Setup Photo).



A D T

6. INFORMATION ON THE TESTING LABORATORIES

We, Bureau Veritas Consumer Products Services (H.K.) Ltd., Taoyuan Branch, were founded in 1988 to provide our best service in EMC, Radio, Telecom and Safety consultation. Our laboratories are accredited and approved by the following approval agencies according to ISO/IEC 17025.

USA	FCC, NVLAP
Germany	TUV Rheinland
Japan	VCCI
Norway	NEMKO
Canada	INDUSTRY CANADA, CSA
R.O.C.	TAF, BSMI, NCC
Netherlands	Telefication
Singapore	GOST-ASIA(MOU)
Russia	CERTIS(MOU)

Copies of accreditation certificates of our laboratories obtained from approval agencies can be downloaded from our web site:

www.adt.com.tw/index.5/phtml. If you have any comments, please feel free to contact us at the following:

Linko EMC/RF Lab:

Tel: 886-2-26052180

Fax: 886-2-26051924

Hsin Chu EMC/RF Lab:

Tel: 886-3-5935343

Fax: 886-3-5935342

Hwa Ya EMC/RF/Safety Telecom Lab:

Tel: 886-3-3183232

Fax: 886-3-3185050

Web Site: www.adt.com.tw

The address and road map of all our labs can be found in our web site also.



A D T

7. APPENDIX A - MODIFICATIONS RECORDERS FOR ENGINEERING CHANGES TO THE EUT BY THE LAB

No any modifications are made to the EUT by the lab during the test.

---END---