

TEST REPORT

Test report no.: 1-2555-01-03/10-A



Testing laboratory

CETECOM ICT Services GmbH
 Untertuerkheimer Straße 6 – 10
 66117 Saarbruecken / Germany
 Phone: + 49 681 5 98 - 0
 Fax: + 49 681 5 98 - 9075
 Internet: <http://www.cetecom.com>
 e-mail: ict@cetecom.com

Accredited test laboratory:
 The test laboratory (area of testing) is accredited according to DIN EN ISO/IEC 17025
 DAR registration number: DGA-PL-176/94-D1
 Area of Testing: Radio/Satellite Communications

Applicant

Oticon A/S
 Kongebakken 9
 2765 Smørum / Denmark
 Phone: +45 39 17 71 00
 Contact: Jørgen Peter Hanuscheck
 e-mail: jnp@oticon.dk
 Phone: +45 39 13 85 38

Manufacturer

Oticon A/S
 Kongebakken 9
 2765 Smørum / Denmark

Test standard/s

47 CFR Part 15	Title 47 of the Code of Federal Regulations; Chapter I-Federal Communications Commission subchapter A - general, Part 15-Radio frequency devices
RSS-210, Issue 8	Low-power Licence-exempt Radiocommunication Devices (All Frequency Bands): Category I Equipment

For further applied test standards please refer to section 3 of this test report.

Test item

Kind of test item:	Nearlink 3,8 MHz
Model name:	Streamer 1.4
FCC ID:	U28STREAM02
IC:	1350B-STREAM02
Frequency [MHz]:	3.8MHz
Power supply:	3.7 V DC by Battery / switching power adapter
Temperature range:	+10 °C to +45 °C

This test report is electronically signed and valid without handwriting signature. For verification of the electronic signatures, the public keys can be requested at the testing laboratory.

Test performed:

Test report authorised:

Andreas Keller

Stefan Bös

1 Table of contents	
1	Table of contents2
2	General information3
2.1	Notes.....3
2.2	Application details.....3
3	Test standard/s3
4	Test environment.....3
5	Test item4
6	Test laboratories sub-contracted4
7	Summary of measurement results5
8	RF measurement testing.....6
8.1	Description of test setup6
8.1.1	Radiated measurements.....6
8.1.2	Conducted measurements.....7
8.2	Additional comments7
8.3	RSP100 test report cover sheet / performance test data8
9	Measurement results.....9
9.1	Timing of the transmitter9
9.2	Bandwidth of the modulated carrier10
9.3	Field strength of the fundamental12
9.4	Field strength of the harmonics and spurious14
9.5	Receiver spurious emissions.....18
9.6	Conducted limits22
10	Test equipment and ancillaries used for tests25
Annex A	Document history27
Annex B	Further information.....27

2 General information

2.1 Notes

The test results of this test report relate exclusively to the test item specified in this test report. CETECOM ICT Services GmbH does not assume responsibility for any conclusions and generalisations drawn from the test results with regard to other specimens or samples of the type of the equipment represented by the test item. The test report may only be reproduced or published in full. Reproduction or publication of extracts from the report requires the prior written approval of CETECOM ICT Services GmbH.

This test report is electronically signed and valid without handwriting signature. For verification of the electronic signatures, the public keys can be requested at the testing laboratory.

2.2 Application details

Date of receipt of order:	2010-09-21
Date of receipt of test item:	2010-09-21
Start of test:	2010-09-21
End of test:	2010-09-22
Person(s) present during the test:	Mr. Hanuscheck, Mr Giedenbacher

3 Test standard/s

Test standard	Version	Test standard description
47 CFR Part 15	2009-10	Title 47 of the Code of Federal Regulations; Chapter I-Federal Communications Commission subchapter A - general, Part 15-Radio frequency devices
RSS-210, Issue 8	2011-12	Low-power Licence-exempt Radiocommunication Devices (All Frequency Bands): Category I Equipment

4 Test environment

Temperature:	T_{nom}	+24 °C during room temperature tests
	T_{max}	+45 °C during high temperature test
	T_{min}	+10 °C during low temperature test
Relative humidity content:		55 %
Air pressure:		not relevant for this kind of testing
Power supply:	V_{nom}	3.7 V DC by Battery / switching power adapter
	V_{max}	4.0 V
	V_{min}	3.2 V

5 Test item

Kind of test item	:	Nearlink 3,8
Type identification	:	Streamer 1.4
S/N serial number	:	Rad.: 0334391, 0346649, 0329048, 0329415, 0334383, 0334384, 0347077, 0346649
HW hardware status	:	Rev. 7
SW software status	:	FW version 4.3.0
Frequency band [MHz]	:	3.8MHz
Type of modulation	:	A1D
Number of channels	:	1
Antenna	:	Coil antenna
Power supply	:	3.7V DC by Battery / switching power adapter
Temperature range	:	+10 °C to +45 °C

6 Test laboratories sub-contracted

None

7 Summary of measurement results

- No deviations from the technical specifications were ascertained**
- There were deviations from the technical specifications ascertained

TC Identifier	Description	Verdict	Date	Remark
RF-Testing	CFR Part 15 RSS 210, Issue 8	Passed	2011-01-31	-/-

Test Specification Clause	Test Case	Temperature Conditions	Power Source Voltages	Pass	Fail	NA	NP	Results
§ 15.35 (c) / RSS-GEN Issue 2 Section 4.5	Timing of the transmitter (Duty cycle correction factor)	Nominal	Nominal	<input checked="" type="checkbox"/>	<input type="checkbox"/>	<input type="checkbox"/>	<input type="checkbox"/>	complies
§ 15.223 / RSS-210 Issue 8	Bandwidth of the modulated carrier	Nominal	Nominal	<input checked="" type="checkbox"/>	<input type="checkbox"/>	<input type="checkbox"/>	<input type="checkbox"/>	complies
§ 15.223 / RSS-210 Issue 8	Fieldstrength of fundamental	Nominal	Nominal	<input checked="" type="checkbox"/>	<input type="checkbox"/>	<input type="checkbox"/>	<input type="checkbox"/>	complies
§ 15.209 (a) / RSS-210 Issue 8	Fieldstrength of harmonics and spurious	Nominal	Nominal	<input checked="" type="checkbox"/>	<input type="checkbox"/>	<input type="checkbox"/>	<input type="checkbox"/>	complies
§ 15.109 / RSS-210 Issue 8	Receiver spurious emissions	Nominal	Nominal	<input checked="" type="checkbox"/>	<input type="checkbox"/>	<input type="checkbox"/>	<input type="checkbox"/>	complies
§ 15.107 / § 15.207	Conducted limits	Nominal	Nominal	<input checked="" type="checkbox"/>	<input type="checkbox"/>	<input type="checkbox"/>	<input type="checkbox"/>	complies

Note: NA = Not Applicable; NP = Not Performed

8 RF measurement testing

8.1 Description of test setup

8.1.1 Radiated measurements

The radiated measurements are performed in vertical and horizontal plane in the frequency range from 9 kHz to 25 GHz in semi-anechoic chambers. The EUT is positioned on a non-conductive support with a height of 0.80 m above a conductive ground plane that covers the whole chamber. The receiving antennas are confirmed with specifications ANSI C63.2-1996 and ANSI C63.4-2009. These antennas can be moved over the height range between 1.0 m and 4.0 m in order to search for maximum field strength emitted from EUT. The measurement distances between EUT and receiving antennas are indicated in the test setups for the various frequency ranges. For each measurement, the EUT is rotated in all three axes until the maximum field strength is received. The wanted and unwanted emissions are received by spectrum analysers where the detector modes and resolution bandwidths over various frequency ranges are set according to requirement ANSI C63-4-2009. Antennas are confirmed with ANSI C63.2-1996 item 15.

Semi anechoic chamber

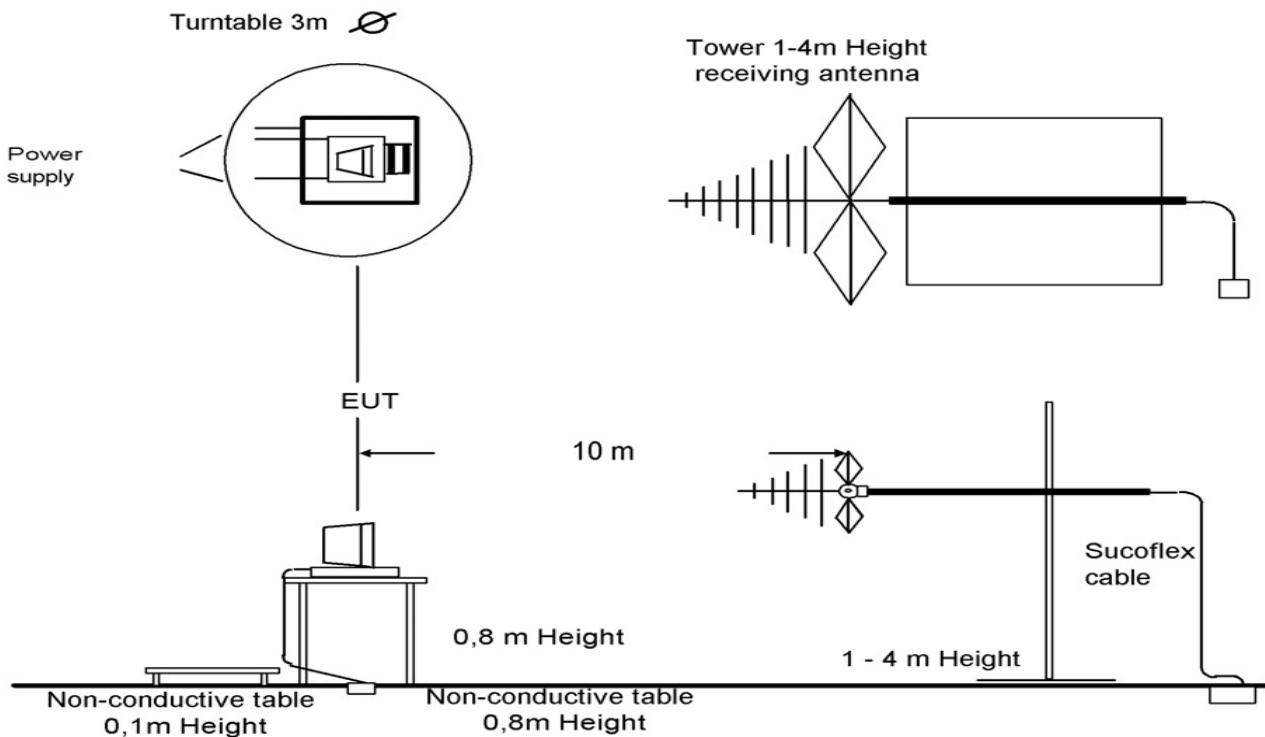

Picture 1: Diagram radiated measurements

9 kHz - 30 MHz:	active loop antenna
30 MHz – 1 GHz:	tri-log antenna
> 1 GHz:	horn antenna

The EUT is powered by an external power supply with nominal voltage. The signalling (if needed) is performed from outside the chamber with a signalling unit by air link using signalling antenna.

8.1.2 Conducted measurements

The EUT's RF signal is coupled out by the antenna connector which is supplied by the manufacturer. The signal is first 10dB attenuated before it is power divided (~6dB loss per branch). The measurement readings on the signalling unit/spectrum analyzer are corrected by the specific test set-up loss. The attenuator, power divider, and the spectrum analyzer are impedance matched on 50 Ohm.

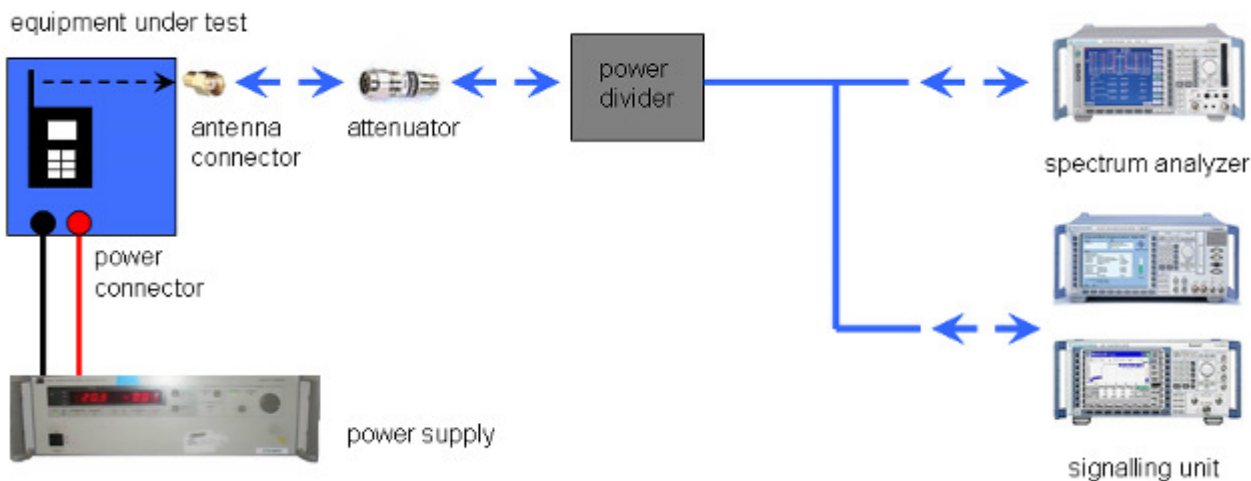

Picture 2: Diagram conducted measurements

8.2 Additional comments

Reference documents: None

Special test descriptions: None

Configuration descriptions: None

8.3 RSP100 test report cover sheet / performance test data

Test Report Number	:	1-2555-01-03/10-A
Equipment Model Number	:	Streamer 1.4
Certification Number	:	1350B-STREAM02
Manufacturer (complete Address)	:	Oticon A/S Kongebakken 9 2765 Smørum / Denmark
Tested to radio standards specification no.	:	RSS 210, Issue 8, Annex 8
Open Area Test Site IC No.	:	IC 3462C-1
Frequency Range or fixed frequency	:	3.8MHz
Field Strength [dB μ V/m]	:	18.0@30m
Occupied bandwidth (99%-BW)	:	278kHz
Type of modulation	:	A1D
Emission Designator (TRC-43)	:	278KA1D
Antenna Information	:	Coil antenna
Transmitter Spurious (worst case) [dB μ V/m @ 3m]:		50dBuV/m noise floor)
Receiver Spurious (worst case) [dB μ V/m @ 3m]:		50dBuV/m noise floor)

ATTESTATION:

DECLARATION OF COMPLIANCE:

I attest that the testing was performed or supervised by me; that the test measurements were made in accordance with the above-mentioned Industry Canada standard(s); and that the equipment identified in this application has been subjected to all the applicable test conditions specified in the Industry Canada standards and all of the requirements of the standard have been met.

Laboratory Manager:

2011-01-31

Andreas Keller

Date

Name

Signature



9 Measurement results

9.1 Timing of the transmitter

Limits:

FCC	IC
CFR Part SUBCLAUSE § 15.35 (c)	RSS-GEN Issue 2 Section 4.5
Timing of the transmitter	
<p>(c) Unless otherwise specified, e.g. Section 15.255(b), when the radiated emission limits are expressed in terms of the average value of the emission, and pulsed operation is employed, the measurement field strength shall be determined by averaging over one complete pulse train, including blanking intervals, as long as the pulse train does not exceed 0.1 seconds. As an alternative (provided the transmitter operates for longer than 0.1 seconds) or in cases where the pulse train exceeds 0.1 seconds, the measured field strength shall be determined from the average absolute voltage during a 0.1 second interval during which the field strength is at its maximum value. The exact method of calculating the average field strength shall be submitted with any application for certification or shall be retained in the measurement data file for equipment subject to notification or verification.</p>	

Duty cycle of the samples with test mode: 50%

In normal use the duty cycle is approximately 2.5% (declared by the manufacturer).

Result: The result of the measurement is passed.

9.2 Bandwidth of the modulated carrier

Limits:

FCC	IC
CFR Part SUBCLAUSE § 15.223	RSS-210 Issue 8
Bandwidth of the modulated carrier	

Measured with the integrated OBW-function of the spectrum analyser Rohde&Schwarz FSIQ26 (measurement criteria is the integrated power in %)

Result:

	Occupied Bandwidth (kHz)
6 dB (75%)	58
20 dB (99%)	278

Sample #0334391

Plots of the measurement

Plot 1: 6dB (75%) – bandwidth

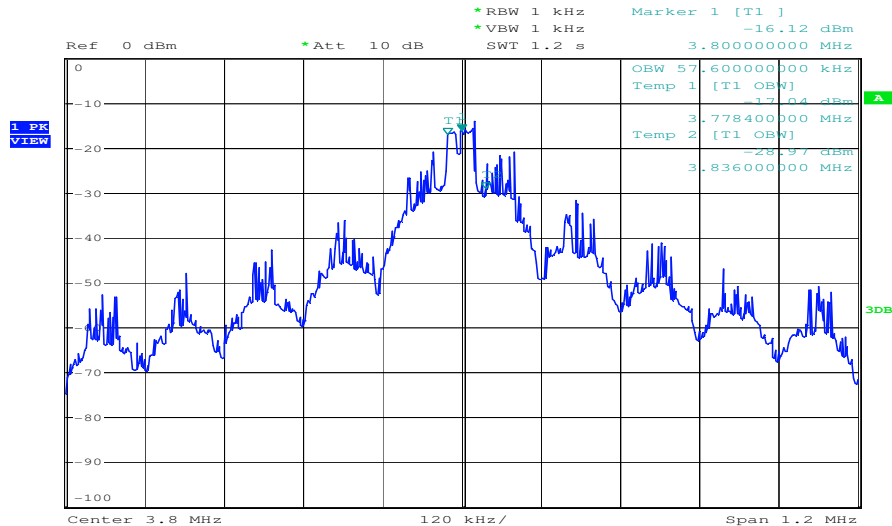

min
Date: 21.SEP.2010 13:38:26

Plot 2: 20dB (99%) - bandwidth

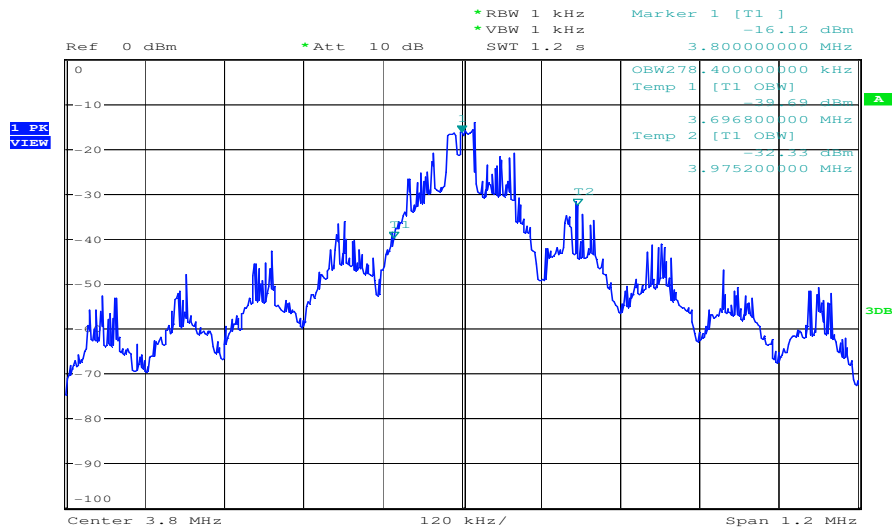

min
Date: 21.SEP.2010 13:38:01

9.3 Field strength of the fundamental

Measurement:

Measurement parameter	
Detector:	Quasi Peak (CISPR)
Resolution bandwidth:	10kHz
Trace-Mode:	Max Hold

Limits:

FCC		IC	
CFR Part SUBCLAUSE § 15.223		RSS-210 Issue 8	
Fundamental Frequency (MHz)	Field strength of Fundamental ($\mu\text{V/m}$)	Measurement distance (m)	
1.705 – 10.0	[15] or [6dB-BW(kHz) / F(MHz)] Whichever is higher	30	

Result:

TEST CONDITIONS		MAXIMUM POWER ($\text{dB}\mu\text{V/m}$)	
Frequency		3.8 MHz	3.8 MHz *)
Mode		at 3 m distance	at 30 m distance
T_{nom}	V_{nom}	58.0	18.0
Measurement uncertainty		±3dB	

*) Recalculation to a measurement distance of 30m with a correction of 40 dB/decade.

Sample #0334391

Result: The result of the measurement is passed.

For information only:

Additional field strength measurement at 3m distance (T_{nom}/V_{nom})	
Sample serial number	Max. power (dB μ V/m)
0329048	57.5
0329415	59.0
0334383	56.5
0334384	56.5
0346649	57.0
0347077	57.5

9.4 Field strength of the harmonics and spurious

Limits:

FCC		IC
SUBCLAUSE § 15.209 (a)		RSS-210 Issue 8
Field strength of the harmonics and spurious.		
Frequency (MHz)	Field strength (µV/m)	Measurement distance (m)
0.009 – 0.490	2400/F(kHz)	300
0.490 – 1.705	24000/F(kHz)	30
1.705 – 30	30 (29.5 dBµV/m)	30
30 – 88	100 (40 dBµV/m)	3
88 – 216	150 (43.5 dBµV/m)	3
216 – 960	200 (46 dBµV/m)	3

Result:

EMISSION LIMITATIONS				
f [MHz]	Detector	Limit max. allowed [dBµV/m]	Amplitude of emission [dBµV/m]	Results
No critical peaks detected				

Result: The result of the measurement is passed.

Plots of the measurements

Plot 1: 9 kHz – 30 MHz (Sample #0334391)

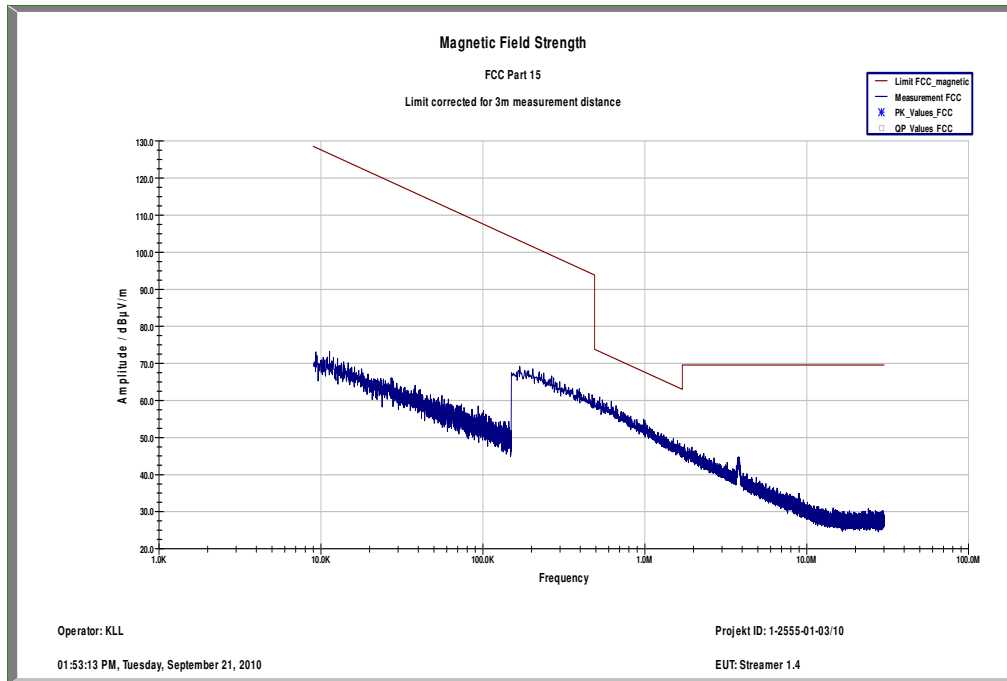

Plot 2: 30 MHz – 1000 MHz

Common Information

EUT: Streamer 1.4
 Serial Number: 0346649
 Test Description: FCC
 Operating Conditions: BT testmode channel idle; /3,84MHz TX / charging
 Operator Name: Kraus
 Comment: Power 115V / 60Hz

Scan Setup: STAN_Fin [EMI radiated]

Hardware Setup: Electric Field (NOS)
 Level Unit: dBµV/m

Subrange	Detectors	IF Bandwidth	Meas. Time	Receiver
30 MHz - 1,05 GHz	QuasiPeak	120 kHz	15 s	Receiver

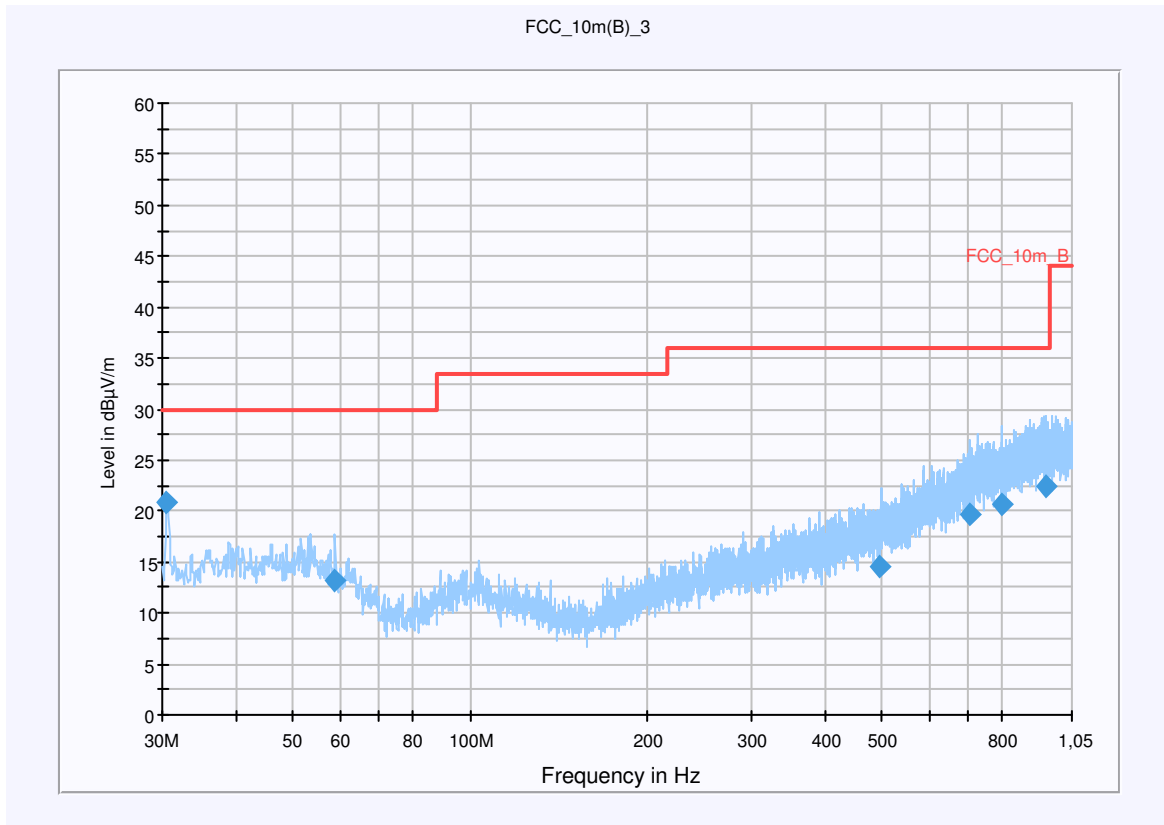

Final Result 1

Frequency (MHz)	QuasiPeak (dBµV/m)	Meas. Time (ms)	Bandwidth (kHz)	Antenna height (cm)	Polarity	Turntable position (deg)	Corr. (dB)	Margin (dB)	Limit (dBµV/m)	Comment
30.481185	20.8	15000.000	120.000	142.0	V	35.0	12.6	9.2	30.0	
58.986000	13.2	15000.000	120.000	164.0	V	236.0	11.9	16.8	30.0	
496.883550	14.6	15000.000	120.000	192.0	V	160.0	18.6	21.4	36.0	
703.425450	19.7	15000.000	120.000	220.0	H	94.0	22.6	16.3	36.0	
796.073850	20.7	15000.000	120.000	98.0	V	200.0	23.8	15.3	36.0	
945.026550	22.5	15000.000	120.000	220.0	V	138.0	25.3	13.5	36.0	

Hardware Setup: EMI radiated\Electric Field (NOS) - [EMI radiated]

Subrange 1

Frequency Range:	30 MHz - 2 GHz
Receiver:	Receiver [ESCI 3] @ GPIB0 (ADR 20), SN 100083/003, FW 4.32
Signal Path:	without Notch FW 1.0
Antenna:	VULB 9163 SN 9163-295, FW --- Correction Table (vertical): VULP6113 Correction Table (horizontal): VULP6113 Correction Table: Cable_EN_1GHz (1005)
Antenna Tower:	Tower [EMCO 2090 Antenna Tower] @ GPIB0 (ADR 8), FW REV 3.12
Turntable:	Turntable [EMCO Turntable] @ GPIB0 (ADR 9), FW REV 3.12

EMC 32 Version 8.10.00

9.5 Receiver spurious emissions

Limits:

FCC		IC
SUBCLAUSE § 15.109		RSS-210 Issue 8
Field strength of the harmonics and spurious.		
Frequency (MHz)	Field strength (µV/m)	Measurement distance (m)
0.009 – 0.490	2400/F(kHz)	300
0.490 – 1.705	24000/F(kHz)	30
1.705 – 30	30 (29.5 dBµV/m)	30
30 – 88	100 (40 dBµv/m)	3
88 – 216	150 (43.5 dBµV/m)	3
216 – 960	200 (46 dBµV/m)	3

Result:

EMISSION LIMITATIONS				
f [MHz]	Detector	Limit max. allowed [dBµV/m]	Amplitude of emission [dBµV/m]	Results
No critical peaks detected				

Result: The result of the measurement is passed.

Plots of the measurements

Plot 1: 9 kHz – 30 MHz (Sample #0334391)

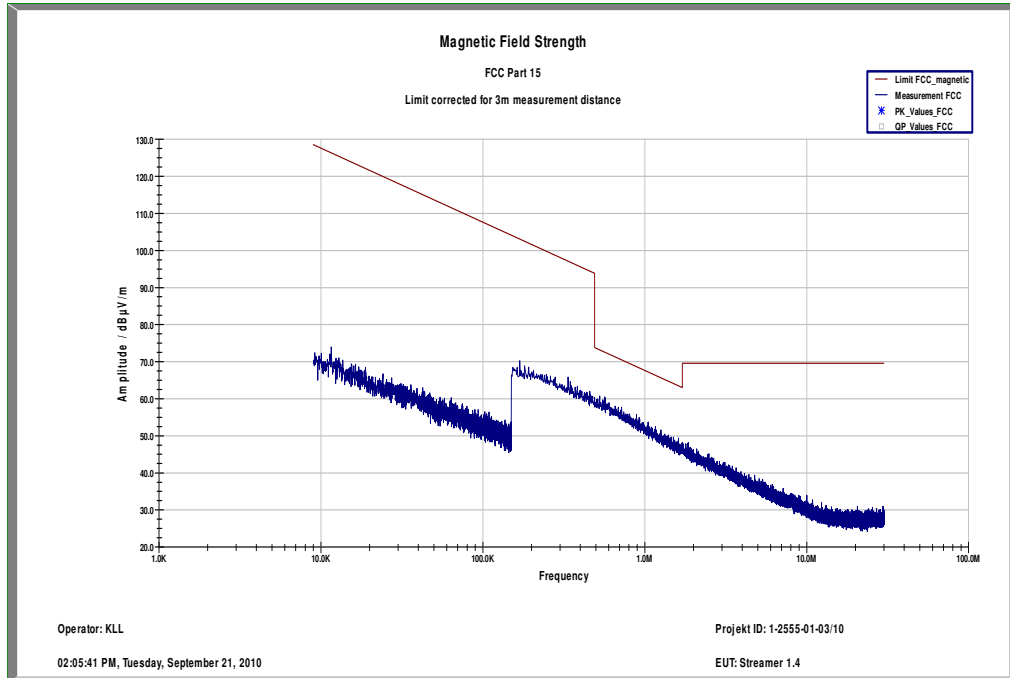

Plot 2: 30 MHz – 1000 MHz

Common Information

EUT: Streamer 1.4
 Serial Number: 0346649
 Test Description: FCC
 Operating Conditions: BT testmode channel idle; /3,84MHz idle / charging
 Operator Name: Kraus
 Comment: Power 115V / 60Hz

Scan Setup: STAN_Fin [EMI radiated]

Hardware Setup: Electric Field (NOS)
 Level Unit: dBµV/m

Subrange **Detectors** **IF Bandwidth** **Meas. Time** **Receiver**
 30 MHz - 1,05 GHz QuasiPeak 120 kHz 15 s Receiver

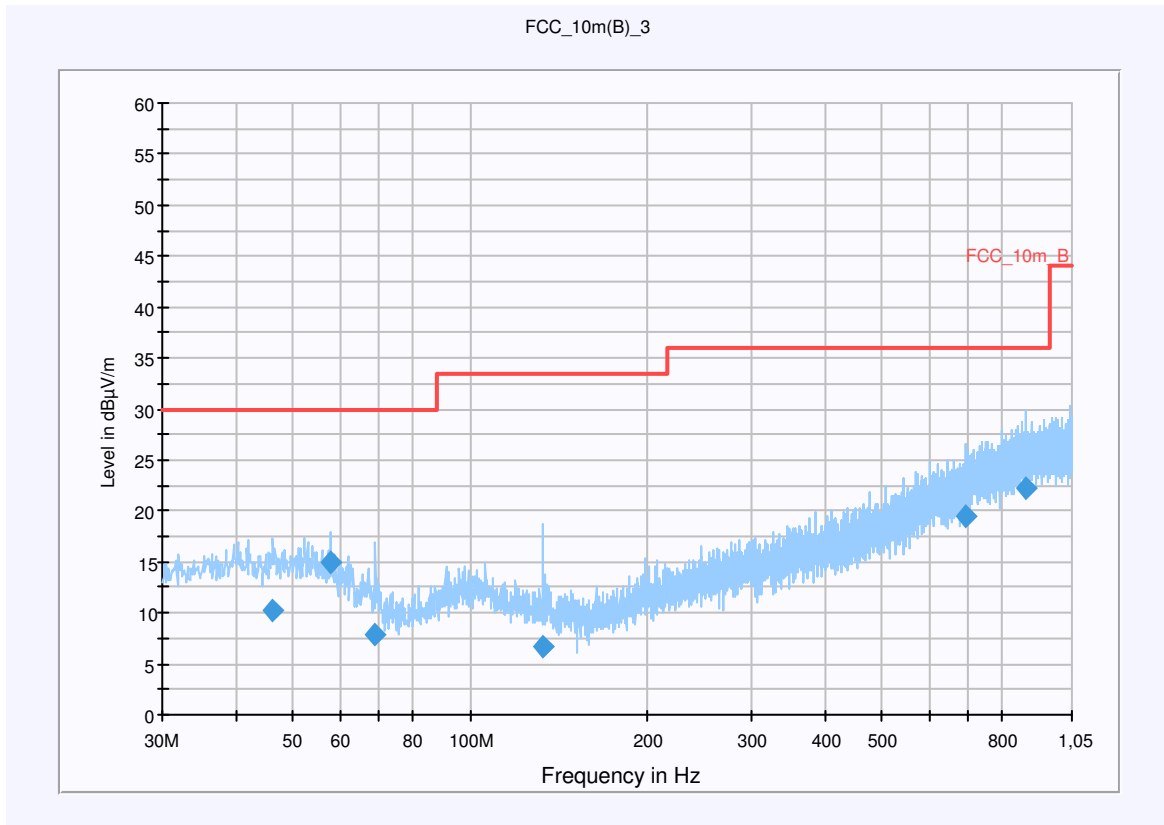

Final Result 1

Frequency (MHz)	QuasiPeak (dBµV/m)	Meas. Time (ms)	Bandwidth (kHz)	Antenna height (cm)	Polarity	Turntable position (deg)	Corr. (dB)	Margin (dB)	Limit (dBµV/m)	Comment
45.979350	10.3	15000.000	120.000	98.0	V	155.0	13.3	19.7	30.0	
57.997200	14.9	15000.000	120.000	185.0	V	228.0	12.1	15.1	30.0	
68.873250	7.8	15000.000	120.000	220.0	V	173.0	9.5	22.2	30.0	
132.742800	6.6	15000.000	120.000	112.0	V	71.0	9.2	26.9	33.5	
694.519650	19.4	15000.000	120.000	143.0	H	220.0	22.4	16.6	36.0	
876.239400	22.2	15000.000	120.000	98.0	V	138.0	24.9	13.8	36.0	

Hardware Setup: EMI radiated\Electric Field (NOS) - [EMI radiated]

Subrange 1

Frequency Range:	30 MHz - 2 GHz
Receiver:	Receiver [ESCI 3] @ GPIB0 (ADR 20), SN 100083/003, FW 4.32
Signal Path:	without Notch FW 1.0
Antenna:	VULB 9163 SN 9163-295, FW --- Correction Table (vertical): VULP6113 Correction Table (horizontal): VULP6113 Correction Table: Cable_EN_1GHz (1005)
Antenna Tower:	Tower [EMCO 2090 Antenna Tower] @ GPIB0 (ADR 8), FW REV 3.12
Turntable:	Turntable [EMCO Turntable] @ GPIB0 (ADR 9), FW REV 3.12

EMC 32 Version 8.10.00

9.6 Conducted limits

Limits:

FCC		IC	
SUBCLAUSE § 15.107 / 15.207		-/-	
Conducted limits			
Frequency of Emission (MHz)	Conducted Limit (dBµV)		
	Quasi-peak	Average	
0.15 – 0.5	66 to 56 *	56 to 46 *	
0.5 – 5	56	46	
5 - 30	60	50	

*Decreases with the logarithm of the frequency

Sample #0334391

Result: The result of the measurement is passed.

Plots of the measurements

Plot 1: 9 kHz to 30 MHz, TX on / phase Line

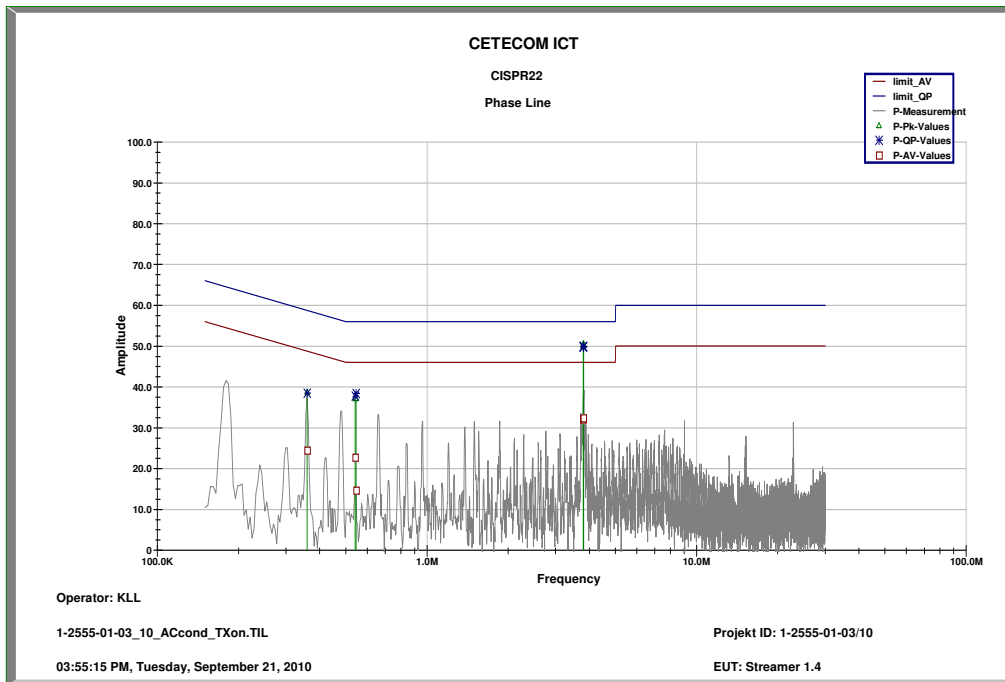

Plot 2: 9 kHz to 30 MHz, TX on / neutral Line

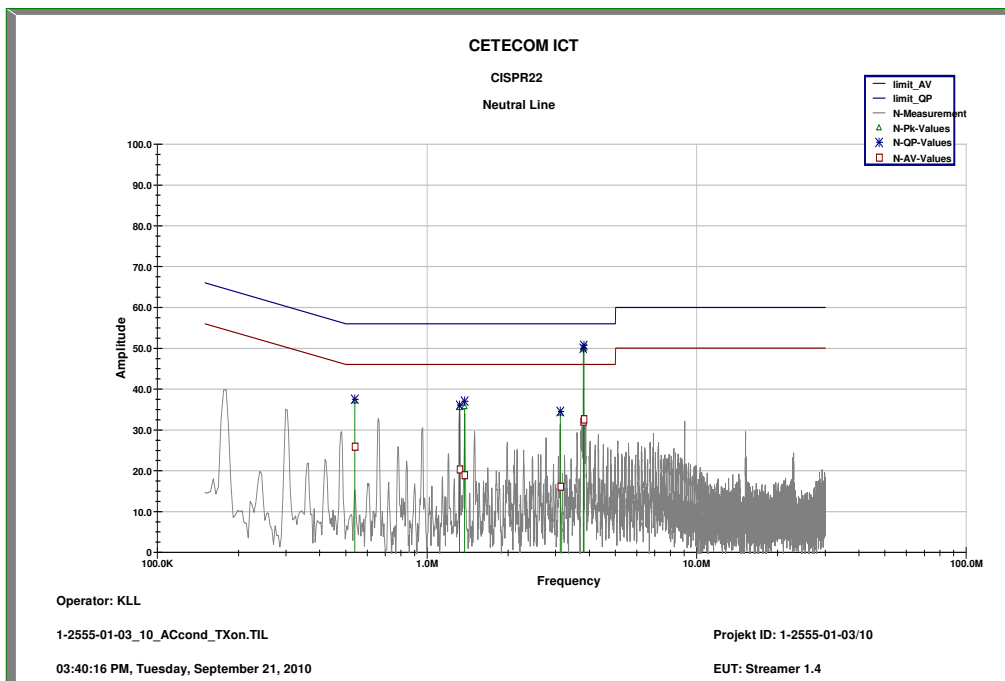

Plot 3: 9 kHz to 30 MHz, idle / phase Line (not mandatory)

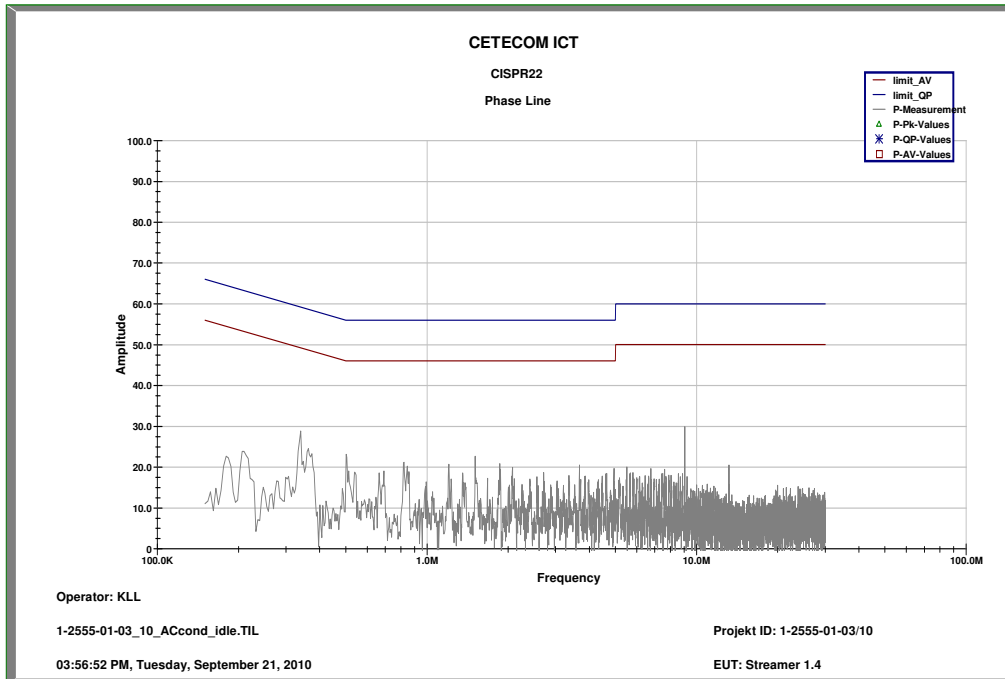

Plot 4: 9 kHz to 30 MHz, idle / neutral Line (not mandatory)

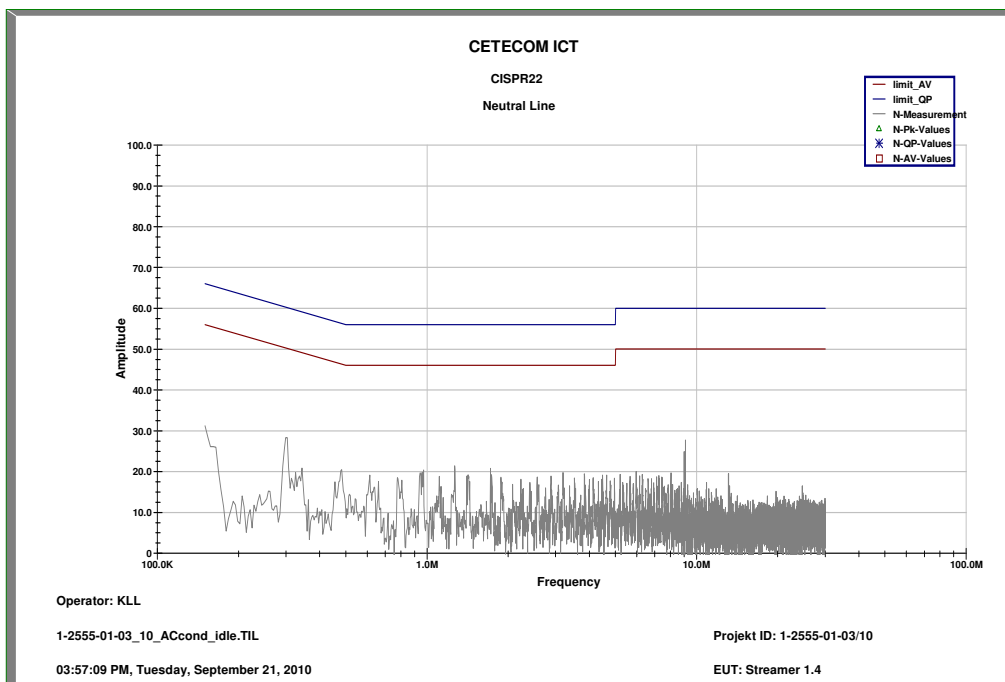

10 Test equipment and ancillaries used for tests

Typically, the calibrations of the test apparatus are commissioned to and performed by an accredited calibration laboratory. The calibration intervals are determined in accordance with the DIN EN ISO/IEC 17025. In addition to the external calibrations, the laboratory executes comparison measurements with other calibrated test systems or effective verifications. Weekly chamber inspections and range calibrations are performed. Where possible, rf-generating and signalling equipment as well as measuring receivers and analyzers are connected to an external high-precision 10 MHz reference (GPS-based or rubidium frequency standard).

In order to simplify the identification of the equipment used at some special tests, some items of test equipment and ancillaries can be provided with an identifier or number in the equipment list below (Labor/Item).

No.	Labor / Item	Equipment	Type	Manufact.	Serial No.	INV. No Cetecom	Kind of Calibration	Last Calibration	Next Calibration
1	n. a.	Signal Analyzer 20Hz-26.5GHz-150 to + 30 DBM	FSIQ26	R&S	835540/018	300002681-0005	k	07.01.2010	07.01.2012
2	n. a.	Spectrum Analyzer 20 Hz - 50 GHz	FSU50	R&S	200012	300003443	ve	01.07.2010	01.07.2012
3	45	Switch-Unit	3488A	HP Meßtechnik	2719A14505	300000368	g	05.03.2009	05.03.2011
4	50	DC power supply, 60Vdc, 50A, 1200 W	6032A	HP Meßtechnik	2920A04466	300000580	k	06.01.2009	06.01.2011
5	n. a.	software	SPS_PHE 1.4f	Spitzberger & Spieß	B5981; 5D1081;B5979	300000210	ne	23.03.2009	
6	n. a.	EMI Test Receiver	ESCI 1166.5950.03	R&S	100083	300003312	k	08.01.2010	08.01.2012
7	n. a.	Analyzer-Reference-System (Harmonics and Flicker)	ARS 16/1	SPS	A3509 07/0 0205	300003314	k	01.06.2009	01.06.2011
8	n. a.	Amplifier	JS42-00502650-28-5A	MITEQ	1084532	300003379	ev		
9	n. a.	Antenna Tower	Model 2175	ETS-LINDGREN	64762	300003745	izw		
10	n. a.	Positioning Controller	Model 2090	ETS-LINDGREN	64672	300003746	izw		
11	n. a.	Turntable Interface-Box	Model 105637	ETS-LINDGREN	44583	300003747	izw		
12	n. a.	TRILOG Broadband Test-Antenna 30 MHz - 3 GHz	VULB9163	Schwarzbeck	295	300003787	k	01.04.2010	01.04.2012
13	n. a.	Spectrum-Analyzer	FSU26	R&S	200809	300003874	k	08.01.2010	08.01.2012
14	n. a.	Horn Antenne 1-26.5GHz	3115	EMCO	9005-3440	300002190	ev		
15	n. a.	Netzgerät 0-20V	6632A	HP Meßtechnik	2851A01814	300000924	k		
16	n. a.	Horn Antenne 1-26.5GHz	3115	EMCO Elektronik	9709-5290	300000212	ev		
17	n. a.	Universal Communication Tester	CMU200	R&S	106826	300003346	k	12.01.2010	12.01.2011
18	n. a.	Software Option für CMU 200	CMU-Kxx	R&S	18	300003345	k	12.01.2010	12.01.2011
19	n. a.	Ultra Stable Notch Filter	WRCD1887.82/1889.55-5EE	Wainwright	1	300000115	ev		
20	n. a.	Funkstörmesempfänger 20Hz- 26,5GHz	ESU26	R&S	100037	300003555	k	08.01.2010	08.01.2011
21	n. a.	HF-Schaltmatrixgrundgerät	TS-RSP 1144.1500K03	R&S	100300	300003556	ev		
22	n. a.	Spiral Antenne	3102L	EMCO	51924	300003385	ne	21.11.2005	21.11.2008
23	n. a.	Spiral Antenne	3102L	EMCO	51918	300003384	k	21.11.2005	21.11.2008
24	n. a.	Signalgenerator 1-20 GHz	SMR20	R&S	101697/020	300003593	k	08.01.2010	08.01.2012
25	n. a.	Turnable Band Reject	WRCT1850/2170-5/40-10EEK	Wainwright	7	300003386	ev		
26	n. a.	Software Option für CMU 200	CMU-K62	R&S	103288	300003600	k	12.01.2010	12.01.2011
27	n. a.	Software Option für CMU 200	CMU-K61	R&S	103354	300003612	k	12.01.2010	12.01.2011
28	n. a.	Software Option für CMU 200	CMU-K64	R&S	102017	300003613	k	12.01.2010	12.01.2011
29	n. a.	Software Option für CMU 200	CMU-K56	R&S	100251	300003614	k	12.01.2010	12.01.2011
30	n. a.	TRILOG Broadband Test-Antenna 30 MHz - 3 GHz	VULB9163	Schwarzbeck	318	300003696	k		

31	n. a.	Tunable Band Reject	WRCT1850/2170-5/40-10EEK	Wainwright	40	300003872	ev		
32	n. a.	Tunable Band Reject	WRCT824/894-5/40-8EEK	Wainwright	27	300003873	ev		
33	n. a.	DC power supply, 60Vdc, 50A, 1200 W	6032A	HP Meßtechnik	2818A03450	300001040	Ve	08.01.2009	08.01.2012
34	n. a.	PowerAttenuator	8325	Byrd	1530	300001595			
35	n. a.	Double-Ridged Waveguide Horn Antenna 1-18.0GHz	3115	EMCO	8812-3088	300001032	vIKI!	05.03.2009	05.03.2011
36	n. a.	Active Loop Antenna	6502	EMCO	2210	300001015	ne		
37	n. a.	Anechoic chamber	FAC 3/5m	MWB / TDK	87400/02	300000996		23.03.2009	
38	Spec.A. 2 2e	System rack for EMI measurement solution	85900	HP I.V.	*	300000222	ne		
39	9	Artificial Mains 9 kHz to 30 MHz	ESH3-Z5	R&S	828576/020	300001210	Ve	06.01.2010	06.01.2012
40	n. a.	Relais Matrix	3488A	HP Meßtechnik	2719A15013	300001156	ne		
41	n. a.	Relais Matrix	PSU	R&S	890167/024	300001168	ne		
42	n. a.	Isolating Transformer	RT5A	Grundig	9242	300001263	ne		
43	n. a.	Three-Way Power Splitter, 50 Ohm	11850C	HP Meßtechnik		300000997	ne		
44	n. a.	Switch / Control Unit	3488A	HP	2605e08770	300001443	ne		
45	n. a.	Band Reject filter	WRCG1855/1910-1835/1925-40/8SS	Wainwright	7	300003350	ev		
46	n. a.	Band Reject filter	WRCG2400/2483-2375/2505-50/10SS	Wainwright	11	300003351	ev		
47	n. a.	TILE-Software Emission	Quantum Change, Modell TILE-ICS/FULL	EMCO	none	300003451	ne		
48	n. a.	Highpass Filter	WHKX2.9/18G-12SS	Wainwright	1	300003492	ev		
49	n. a.	Highpass Filter	WHK1.1/15G-10SS	Wainwright	3	300003255	ev		
50	n. a.	Highpass Filter	WHKX7.0/18G-8SS	Wainwright	18	300003789	ne		
51	n. a.	PSA Spectrum Analyzer 3 Hz - 26.5 GHz	E4440A	Agilent Technologies	MY48250080	300003812	k		
52	n. a.	MXG Microwave Analog Signal Generator	N5183A	Agilent Technologies	MY47420220	300003813	k		
53	n. a.	RF Filter Section 9kHz - 1GHz	N9039A	Agilent Technologies	MY48260003	300003825	vIKI!		
54	n. a.	TRILOG Broadband Test-Antenna 30 MHz - 3 GHz	VULB9163	Schwarzbeck	371	300003854	vIKI!	17.12.2008	17.12.2010
55	n. a.	Test Receiver	ESH2	R&S	871921/095	300002505	k	02/2010	02/2012
56	n. a.	Loop Antenna	HFH2-Z2	R&S	872096/61	300001824	k	18.11.2009	18.11.2011

Agenda: Kind of Calibration

- | | | | |
|-------|--|-----|--|
| k | calibration / calibrated | EK | limited calibration |
| ne | not required (k, ev, izw, zw not required) | zw | cyclical maintenance (external cyclical maintenance) |
| ev | periodic self verification | izw | internal cyclical maintenance |
| Ve | long-term stability recognized | g | blocked for accredited testing |
| vIKI! | Attention: extended calibration interval | *) | next calibration ordered / currently in progress |
| NK! | Attention: not calibrated | | |

Annex A Document history

Version	Applied changes	Date of release
1.0	Initial release	2010-12-21
-A	IC standard up-date; pictures removed	2011-01-31

Annex B Further information

Glossary

DUT	-	Device under Test
EMC	-	Electromagnetic Compatibility
EUT	-	Equipment under Test
FCC	-	Federal Communication Commission
FCC ID	-	Company Identifier at FCC
HW	-	Hardware
IC	-	Industry Canada
Inv. No.	-	Inventory number
N/A	-	not applicable
S/N	-	Serial Number
SW	-	Software