

## TEST REPORT

Test report no.: 1-2071-01-03/10-C



### Testing laboratory

**CETECOM ICT Services GmbH**  
Untertuerkheimer Straße 6 – 10  
66117 Saarbruecken / Germany  
Phone: + 49 681 5 98 - 0  
Fax: + 49 681 5 98 - 9075  
Internet: <http://www.cetecom.com>  
e-mail: [ict@cetecom.com](mailto:ict@cetecom.com)

**Accredited test laboratory:**  
The test laboratory (area of testing) is accredited according to DIN EN ISO/IEC 17025  
DAR registration number: DGA-PL-176/94-D1  
Area of Testing: Radio/Satellite Communications

### Applicant

**Oticon A/S**  
Kongebakken 9  
2765 Smørum / Denmark  
Phone: +45 39 17 71 00  
Contact: Kristine Klitgaard Pedersen  
e-mail: [kkp@oticon.dk](mailto:kkp@oticon.dk)  
Phone: +45 39 13 85 83

### Manufacturer

**Oticon A/S**  
Kongebakken 9  
2765 Smørum / Denmark

### Test standard/s

47 CFR Part 15      Title 47 of the Code of Federal Regulations; Chapter I-Federal Communications Commission  
subchapter A - general, Part 15-Radio frequency devices

For further applied test standards please refer to section 3 of this test report.

### Test item

**Kind of test item:**      **FM Transmitter**  
**Model name:**      **AMIGO T30/T31**  
**FCC ID:**      **U28AT31**  
**IC:**      **1350B-AT31**  
**Frequency [MHz]:**      **3.7**  
**Power supply:**      **1.5V NiMH battery**  
**Temperature range:**      **0 °C to 50 °C**

This test report is electronically signed and valid without handwriting signature. For verification of the electronic signatures, the public keys can be requested at the testing laboratory.

**Test performed:**

**Test report authorised:**

Andreas Keller

Stefan Bös

**1 Table of contents**

1 Table of contents .....2

2 General information .....3

    2.1 Notes.....3

    2.2 Application details.....3

3 Test standard/s .....3

4 Test environment.....3

5 Test item .....4

6 Test laboratories sub-contracted .....4

7 Summary of measurement results .....5

8 RF measurement testing.....6

    8.1 Description of test setup .....6

        8.1.1 Radiated measurements.....6

        8.1.2 Conducted measurements.....7

    8.2 Additional comments .....7

    8.3 RSP100 test report cover sheet / performance test data .....8

9 Measurement results.....9

    9.1 Timing of the transmitter .....9

    9.2 Bandwidth of the modulated carrier .....10

    9.3 Field strength of the fundamental .....12

    9.4 Fieldstrength of the harmonics and spurious .....13

    9.5 Receiver spurious emissions.....18

    9.6 Conducted limits .....23

10 Test equipment and ancillaries used for tests .....24

Annex A Document history .....26

Annex B Further information.....26

## 2 General information

### 2.1 Notes

The test results of this test report relate exclusively to the test item specified in this test report. CETECOM ICT Services GmbH does not assume responsibility for any conclusions and generalisations drawn from the test results with regard to other specimens or samples of the type of the equipment represented by the test item. The test report may only be reproduced or published in full. Reproduction or publication of extracts from the report requires the prior written approval of CETECOM ICT Services GmbH.

This test report is electronically signed and valid without handwriting signature. For verification of the electronic signatures, the public keys can be requested at the testing laboratory.

### 2.2 Application details

Date of receipt of order:	2010-06-28
Date of receipt of test item:	2010-08-31
Start of test:	2010-08-31
End of test:	2010-09-14
Person(s) present during the test:	Mr. Arne Lindbjerg Pedersen Mr. Oli Bovardsen (2010-08-31 to 2010-09-03)

## 3 Test standard/s

Test standard	Version	Test standard description
47 CFR Part 15	2009-10	Title 47 of the Code of Federal Regulations; Chapter I-Federal Communications Commission subchapter A - general, Part 15-Radio frequency devices

## 4 Test environment

Temperature:	$T_{nom}$	23 °C during room temperature tests
	$T_{max}$	
	$T_{min}$	
Relative humidity content:		52 %
Air pressure:		not relevant for this kind of testing
Power supply:	$V_{nom}$	1.5 V NiMH battery
	$V_{max}$	1.0 V
	$V_{min}$	1.6 V

**5 Test item**

Kind of test item	:	<b>FM Transmitter</b>
Type identification	:	<b>AMIGO T30/T31</b>
S/N serial number	:	<b>Rad.: Sample #3, sample#4, sample #26</b>
HW hardware status	:	<b>unknown</b>
SW software status	:	<b>unknown</b>
Frequency band	:	<b>3.7 MHz</b>
Type of modulation	:	<b>A1D</b>
Number of channels	:	<b>1</b>
Antenna	:	<b>Integrated coil antenna</b>
Power supply	:	<b>1.5 V NiMH battery</b>
Temperature range	:	<b>0°C to 50 °C</b>

**6 Test laboratories sub-contracted**

None

**7 Summary of measurement results**

- No deviations from the technical specifications were ascertained**
- There were deviations from the technical specifications ascertained

TC Identifier	Description	Verdict	Date	Remark
RF-Testing	CFR Part 15 RSS 210, Issue 7	Passed	2010-11-17	-/-

Test Specification Clause	Test Case	Temperature Conditions	Power Source Voltages	Pass	Fail	NA	NP	Results
§ 15.35 (c) / RSS-GEN Issue 2 Section 4.5	Timing of the transmitter (Duty cycle correction factor )	Nominal	Nominal	<input checked="" type="checkbox"/>	<input type="checkbox"/>	<input type="checkbox"/>	<input type="checkbox"/>	complies
§ 15.223 / RSS-210 Issue 7	Bandwidth of the modulated carrier	Nominal	Nominal	<input checked="" type="checkbox"/>	<input type="checkbox"/>	<input type="checkbox"/>	<input type="checkbox"/>	complies
§ 15.223 / RSS-210 Issue 7	Fieldstrength of fundamental	Nominal	Nominal	<input checked="" type="checkbox"/>	<input type="checkbox"/>	<input type="checkbox"/>	<input type="checkbox"/>	complies
§ 15.209 (a) / RSS-210 Issue 7	Fieldstrength of harmonics and spurious	Nominal	Nominal	<input checked="" type="checkbox"/>	<input type="checkbox"/>	<input type="checkbox"/>	<input type="checkbox"/>	complies
§ 15.109 / RSS-210 Issue 7	Receiver spurious emissions	Nominal	Nominal	<input checked="" type="checkbox"/>	<input type="checkbox"/>	<input type="checkbox"/>	<input type="checkbox"/>	complies
§ 15.109 / § 15.207	Conducted limits	Nominal	Nominal	<input type="checkbox"/>	<input type="checkbox"/>	<input checked="" type="checkbox"/>	<input type="checkbox"/>	-

**Note:** NA = Not Applicable; NP = Not Performed

## 8 RF measurement testing

### 8.1 Description of test setup

#### 8.1.1 Radiated measurements

The radiated measurements are performed in vertical and horizontal plane in the frequency range from 9 kHz to 25 GHz in semi-anechoic chambers. The EUT is positioned on a non-conductive support with a height of 0.80 m above a conductive ground plane that covers the whole chamber. The receiving antennas are confirmed with specifications ANSI C63.2-1996 and ANSI C63.4-2009. These antennas can be moved over the height range between 1.0 m and 4.0 m in order to search for maximum field strength emitted from EUT. The measurement distances between EUT and receiving antennas are indicated in the test setups for the various frequency ranges. For each measurement, the EUT is rotated in all three axes until the maximum field strength is received. The wanted and unwanted emissions are received by spectrum analysers where the detector modes and resolution bandwidths over various frequency ranges are set according to requirement ANSI C63.4-2009. Antennas are confirmed with ANSI C63.2-1996 item 15.

Semi anechoic chamber

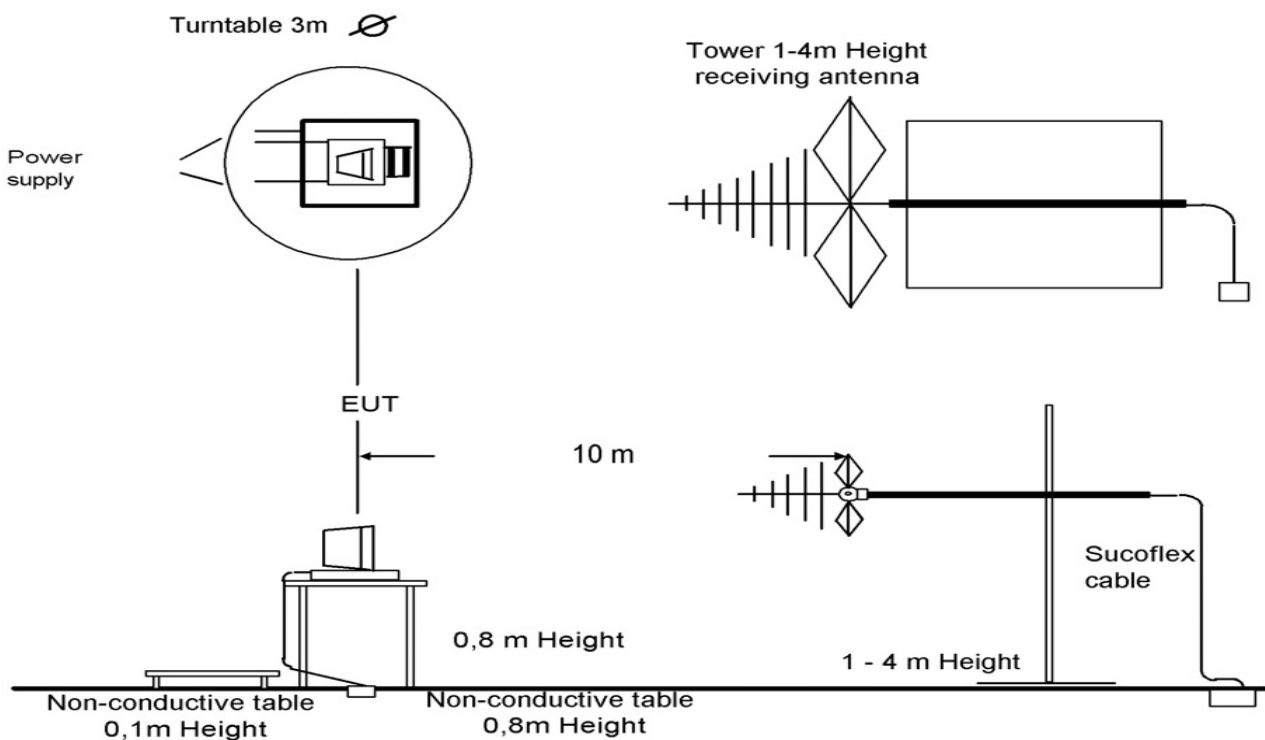

Picture 1: Diagram radiated measurements

9 kHz - 30 MHz:	active loop antenna
30 MHz – 1 GHz:	tri-log antenna
> 1 GHz:	horn antenna

The EUT is powered by an external power supply with nominal voltage. The signalling (if needed) is performed from outside the chamber with a signalling unit by air link using signalling antenna.

### 8.1.2 Conducted measurements

The EUT's RF signal is coupled out by the antenna connector which is supplied by the manufacturer. The signal is first 10dB attenuated before it is power divided (~6dB loss per branch). The measurement readings on the signalling unit/spectrum analyzer are corrected by the specific test setup loss. The attenuator, power divider, and the spectrum analyzer are impedance matched on 50 Ohm.

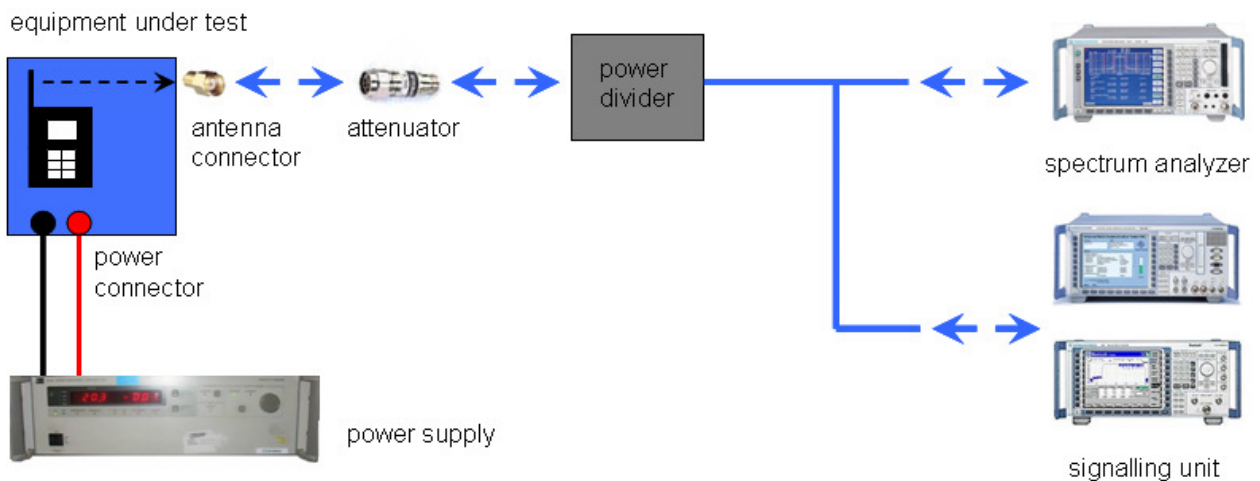

Picture 2: Diagram conducted measurements

### 8.2 Additional comments

Reference documents:	Product information AMIGO T30/T31 XXXXXXUK / 09/10
Special test descriptions:	None
Configuration descriptions:	Permanent transmit test mode. Idle mode via manufacturer software tool. When charging unit is connected, the device is disabled, battery charging only.

### 8.3 RSP100 test report cover sheet / performance test data

Test Report Number	:	1-2071-01-03/10-C
Equipment Model Number	:	AMIGO T30/T31
Certification Number	:	1350B-AT31
Manufacturer (complete Address)	:	Oticon A/S Kongebakken 9 2765 Smørum / Denmark
Tested to radio standards specification no.	:	RSS 210, Issue 7, Annex 8
Open Area Test Site IC No.	:	IC 3462C-1
Frequency Range or fixed frequency	:	3.7MHz
Field Strength (at which distance)	:	51.5 dB $\mu$ V/m @ 3m
Occupied bandwidth (99%-BW)	:	377 kHz
Type of modulation	:	A1D
Emission Designator (TRC-43)	:	377KA1D
Antenna Information	:	Integrated coil antenna
Transmitter Spurious (worst case) [dB $\mu$ V/m @ 3m]:		50 (noise floor)
Receiver Spurious (worst case) [dB $\mu$ V/m @ 3m]:		50 (noise floor)

#### ATTESTATION:

#### DECLARATION OF COMPLIANCE:

I attest that the testing was performed or supervised by me; that the test measurements were made in accordance with the above-mentioned Industry Canada standard(s); and that the equipment identified in this application has been subjected to all the applicable test conditions specified in the Industry Canada standards and all of the requirements of the standard have been met.

Laboratory Manager:



2010-11-17

Signature



**9 Measurement results**

**9.1 Timing of the transmitter**

**Limits:**

FCC	IC
CFR Part SUBCLAUSE § 15.35 (c)	RSS-GEN Issue 2 Section 4.5
Timing of the transmitter	
<p>(c) Unless otherwise specified, e.g. Section 15.255(b), when the radiated emission limits are expressed in terms of the average value of the emission, and pulsed operation is employed, the measurement field strength shall be determined by averaging over one complete pulse train, including blanking intervals, as long as the pulse train does not exceed 0.1 seconds. As an alternative (provided the transmitter operates for longer than 0.1 seconds) or in cases where the pulse train exceeds 0.1 seconds, the measured field strength shall be determined from the average absolute voltage during a 0.1 second interval during which the field strength is at its maximum value. The exact method of calculating the average field strength shall be submitted with any application for certification or shall be retained in the measurement data file for equipment subject to notification or verification.</p>	

Test sample with permanent transmit test mode.

**In normal use the duty cycle is approximately 5% (declared by the manufacturer).**

**Result: The result of the measurement is passed.**

## 9.2 Bandwidth of the modulated carrier

### Limits:

FCC	IC
CFR Part SUBCLAUSE § 15.223	RSS-210 Issue 7
Bandwidth of the modulated carrier	

Measured with the integrated OBW-function of the spectrum analyser Rohde&Schwarz FSIQ26 (measurement criteria is the integrated power in %)

### Result:

	Occupied Bandwidth (kHz)
6 dB (75%)	126
20 dB (99%)	377

Plots of the measurement

Sample #3

Plot 1: 6dB (75%) – bandwidth

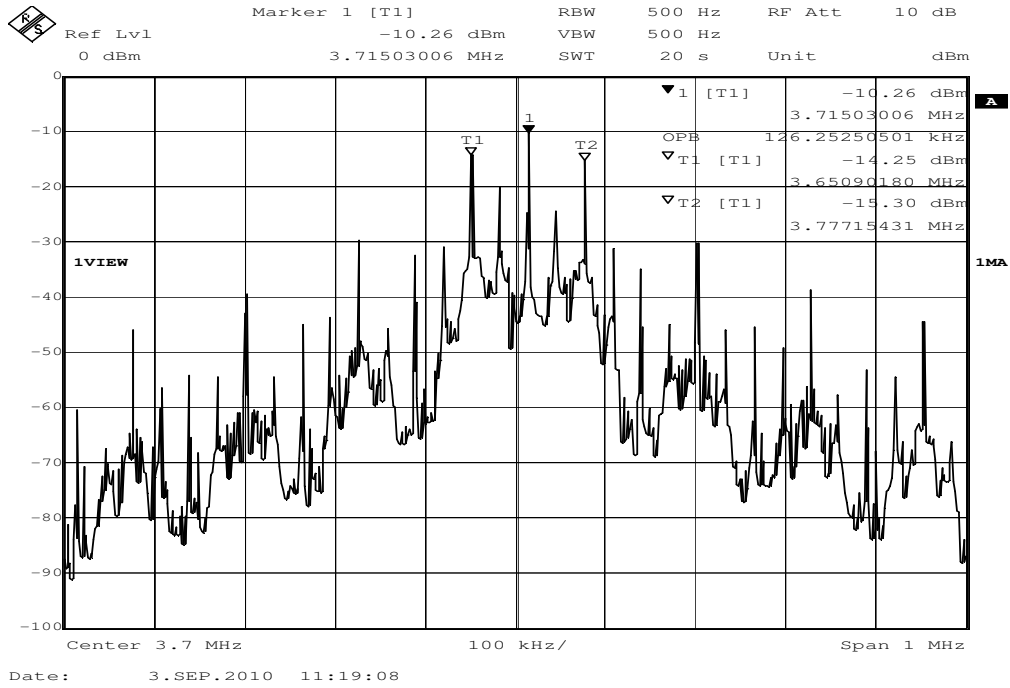

Plot 2: 20dB (99%) - bandwidth

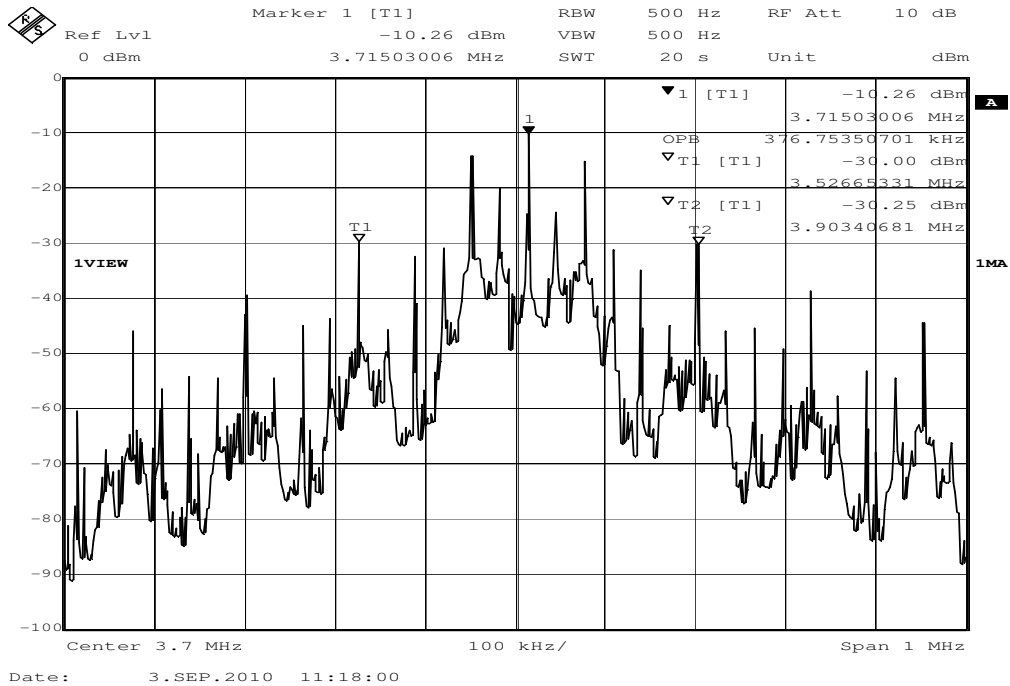

### 9.3 Field strength of the fundamental

#### Measurement:

Measurement parameter	
Detector:	Quasi Peak (CISPR)
Resolution bandwidth:	10kHz
Trace-Mode:	Max Hold

#### Limits:

FCC		IC	
CFR Part SUBCLAUSE § 15.223		RSS-210 Issue 7	
Fundamental Frequency (MHz)	Field strength of Fundamental ( $\mu\text{V/m}$ )	Measurement distance (m)	
1.705 – 10.0	[15] or [6dB-BW(kHz) / F(MHz)] Whichever is higher	30	

#### Result:

TEST CONDITIONS		MAXIMUM POWER ( $\text{dB}\mu\text{V/m}$ )	
Frequency		3.7 MHz	3.7 MHz
Mode		at 3 m distance	at 30 m distance
$T_{\text{nom}}$	$V_{\text{nom}}$	51.5	11.5
Measurement uncertainty		$\pm 3\text{dB}$	

Recalculation to a measurement distance of 30m with a correction of 40 dB/decade.

**Result:** The result of the measurement is passed.

## 9.4 Fieldstrength of the harmonics and spurious

**Limits:**

FCC		IC
SUBCLAUSE § 15.209 (a)		RSS-210 Issue 7
Field strength of the harmonics and spurious.		
Frequency (MHz)	Field strength ( $\mu\text{V/m}$ )	Measurement distance (m)
0.009 – 0.490	2400/F(kHz)	300
0.490 – 1.705	24000/F(kHz)	30
1.705 – 30	30 (29.5 dB $\mu\text{V/m}$ )	30
30 – 88	100 (40 dB $\mu\text{v/m}$ )	3
88 – 216	150 (43.5 dB $\mu\text{V/m}$ )	3
216 – 960	200 (46 dB $\mu\text{V/m}$ )	3

**Result:**

EMISSION LIMITATIONS				
f [MHz]	Detector	Limit max. allowed [dB $\mu\text{V/m}$ ]	Amplitude of emission [dB $\mu\text{V/m}$ ]	Results
No critical peaks detected				

**Result:** The result of the measurement is passed.

Plots of the measurements

Sample #3

Plot 1: 9 kHz – 30 MHz, loop antenna 0°

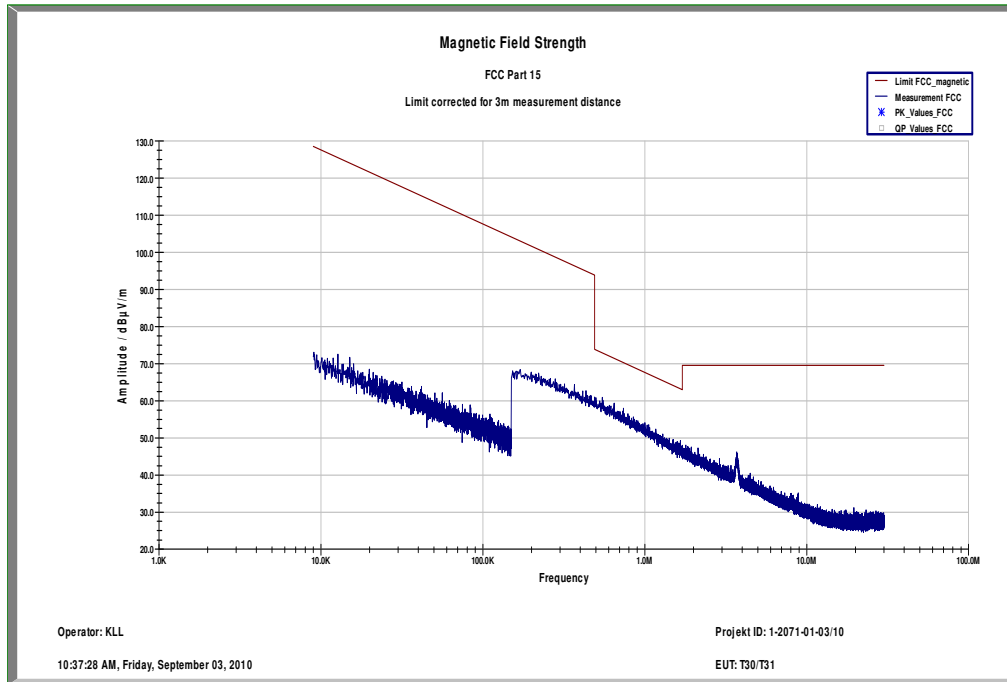

Plot 2: 9 kHz – 30 MHz, loop antenna 90°

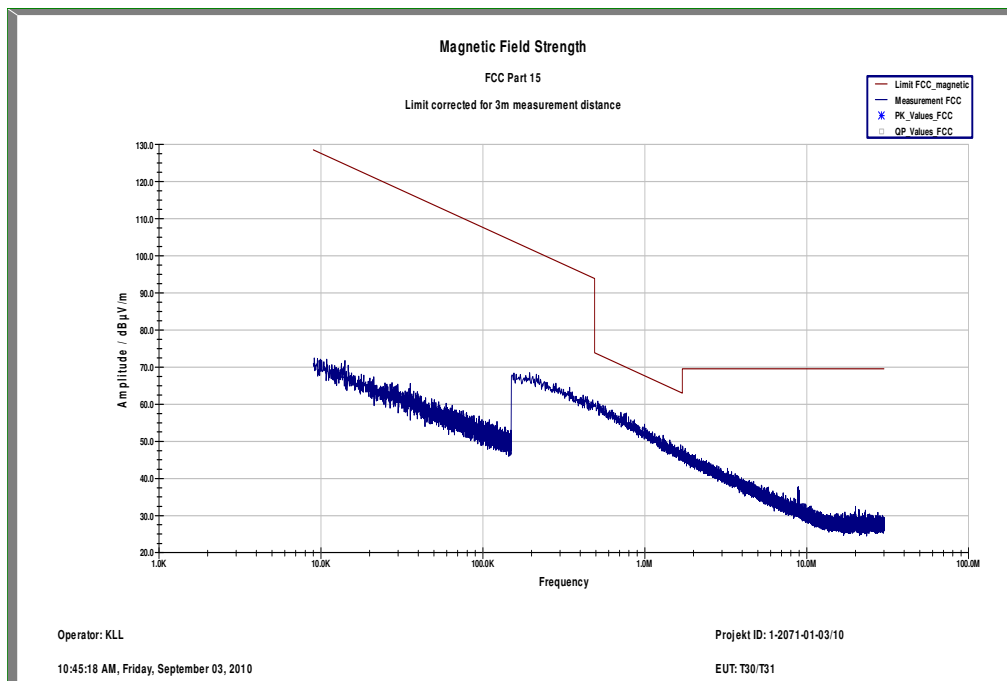

Plot 3: 30 MHz – 1000 MHz

EUT: AMIGO T30/T31  
 Serial Number: # 03  
 Test Description: FCC part 15 C @ 10 m  
 Operating Conditions: TX on 3,7 MHz; TX on 216 MHz  
 Operator Name: LNG  
 Comment: Battery Powered; Carrier frequency on 216 MHz

**Scan Setup: STAN\_Fin [EMI radiated]**

Hardware Setup: Electric Field (NOS)  
 Level Unit: dBµV/m  
**Subrange**                      **Detectors**                      **IF Bandwidth**                      **Meas. Time**                      **Receiver**  
 30 MHz – 1,05 GHz              QuasiPeak                      120 kHz                      15 s                      Receiver

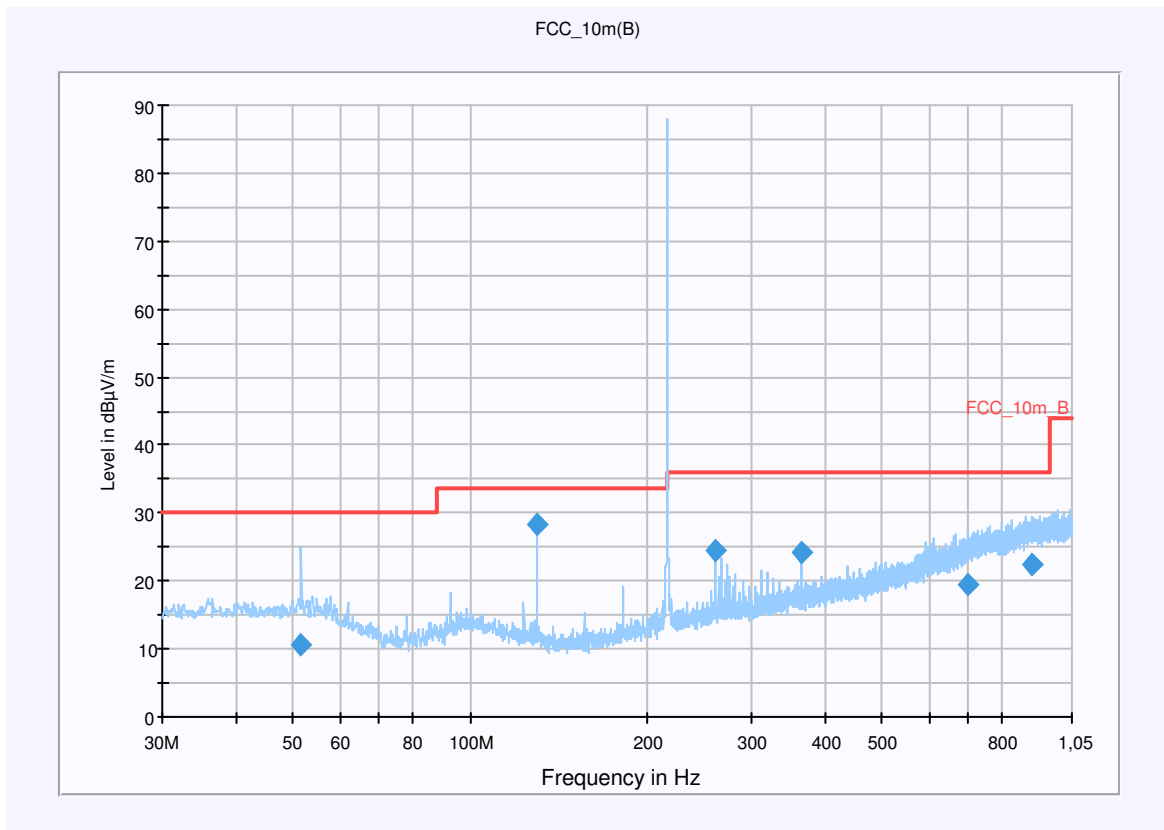

**Final Result 1**

Frequency (MHz)	QuasiPeak (dBµV/m)	Meas. Time (ms)	Bandwidth (kHz)	Antenna height (cm)	Polarity	Turntable position (deg)	Corr. (dB)	Margin (dB)	Limit (dBµV/m)	Comment
51.584100	10.6	15000.000	120.000	200.0	V	161.0	13.2	19.4	30.0	
129.996300	28.3	15000.000	120.000	121.0	V	282.0	9.4	5.2	33.5	
260.001450	24.6	15000.000	120.000	113.0	V	7.0	13.6	11.4	36.0	
364.010400	24.2	15000.000	120.000	100.0	V	3.0	16.3	11.8	36.0	
696.945900	19.5	15000.000	120.000	208.0	H	39.0	22.4	16.5	36.0	
901.247400	22.3	15000.000	120.000	100.0	H	268.0	25.2	13.7	36.0	

**Hardware Setup: EMI radiated\Electric Field (NOS) – [EMI radiated]**

Subrange 1

Frequency Range:	30 MHz – 2 GHz
Receiver:	Receiver [ESCI 3] @ GPIB0 (ADR 20), SN 100083/003, FW 4.32
Signal Path:	without Notch FW 1.0
Antenna:	VULB 9163 SN 9163-295, FW --- Correction Table (vertical): VULP6113 Correction Table (horizontal): VULP6113 Correction Table : Cable_EN_1GHz (1005)
Antenna Tower:	Tower [EMCO 2090 Antenna Tower] @ GPIB0 (ADR 8), FW REV 3.12
Turntable:	Turntable [EMCO Turntable] @ GPIB0 (ADR 9), FW REV 3.12

EMC 32 Version 8.10.00



Sample #3

Plot 4: 1 GHz – 12.75 GHz, antenna vertical

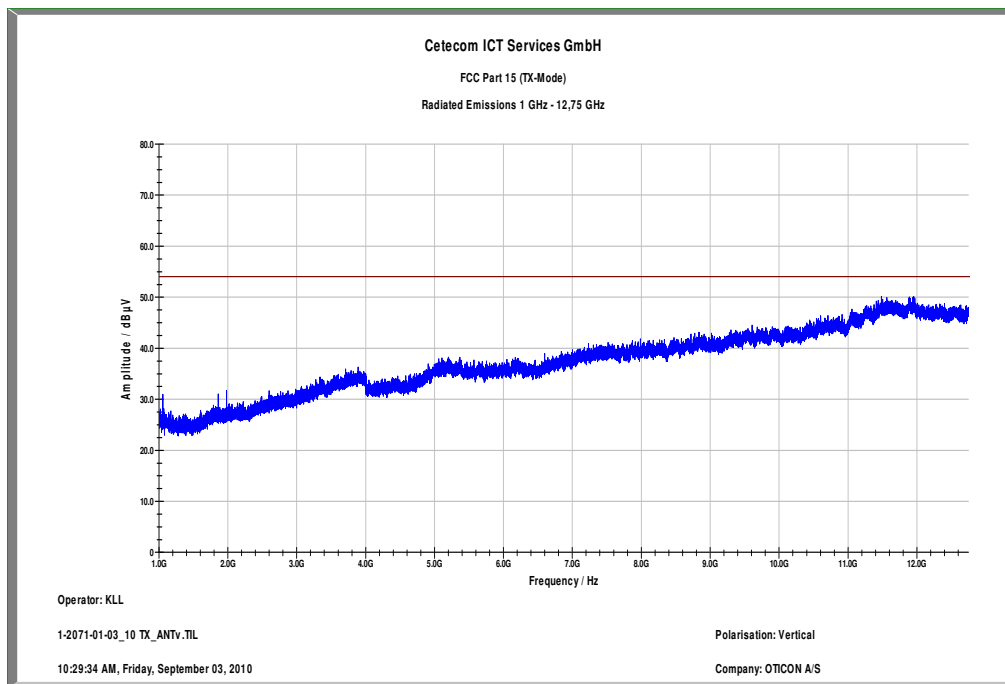

Plot 5: 1 GHz – 12.75 GHz, antenna horizontal

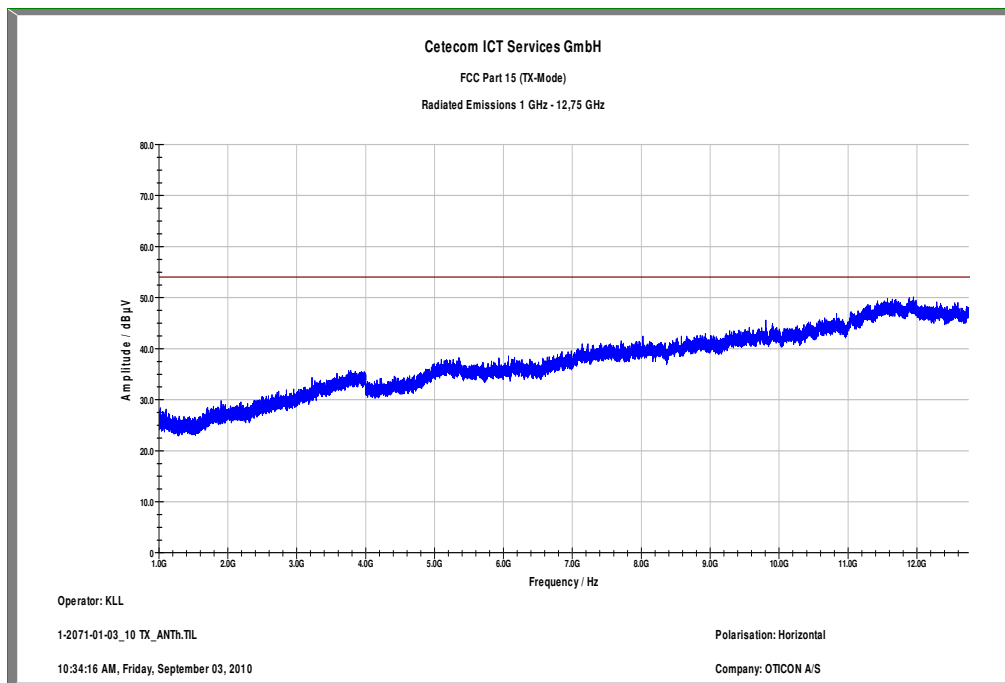

## 9.5 Receiver spurious emissions

**Limits:**

FCC		IC
SUBCLAUSE § 15.109		RSS-210 Issue 7
Field strength of the harmonics and spurious.		
Frequency (MHz)	Field strength (µV/m)	Measurement distance (m)
0.009 – 0.490	2400/F(kHz)	300
0.490 – 1.705	24000/F(kHz)	30
1.705 – 30	30 (29.5 dBµV/m)	30
30 – 88	100 (40 dBµv/m)	3
88 – 216	150 (43.5 dBµV/m)	3
216 – 960	200 (46 dBµV/m)	3

**Result:**

EMISSION LIMITATIONS				
f [MHz]	Detector	Limit max. allowed [dBµV/m]	Amplitude of emission [dBµV/m]	Results
No critical peaks detected				

**Result:** The result of the measurement is passed.

Plots of the measurements

Sample #26

Plot 1: 9 kHz – 30 MHz

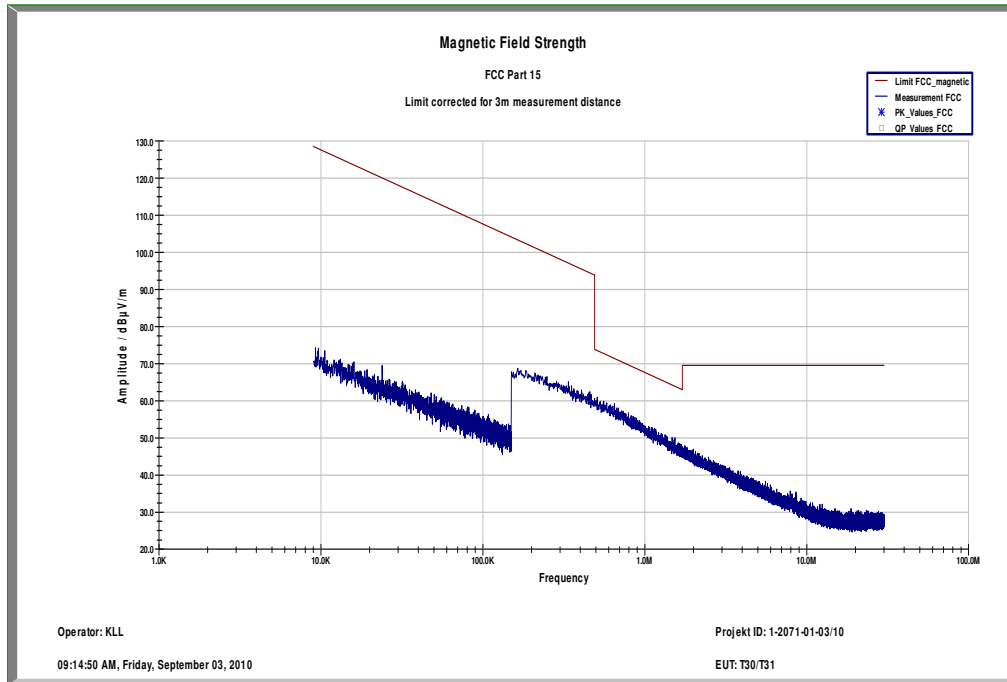

Plot 2: 30 MHz – 1000 MHz

EUT: AMIGO T30/T31  
 Serial Number: # 04  
 Test Description: FCC part 95  
 Operating Conditions: idle  
 Operator Name: LNG  
 Comment: Battery Powered

**Scan Setup: STAN\_Fin [EMI radiated]**

Hardware Setup: Electric Field (NOS)  
 Level Unit: dBµV/m

Subrange	Detectors	IF Bandwidth	Meas. Time	Receiver
30 MHz – 1,05 GHz	QuasiPeak	120 kHz	15 s	Receiver

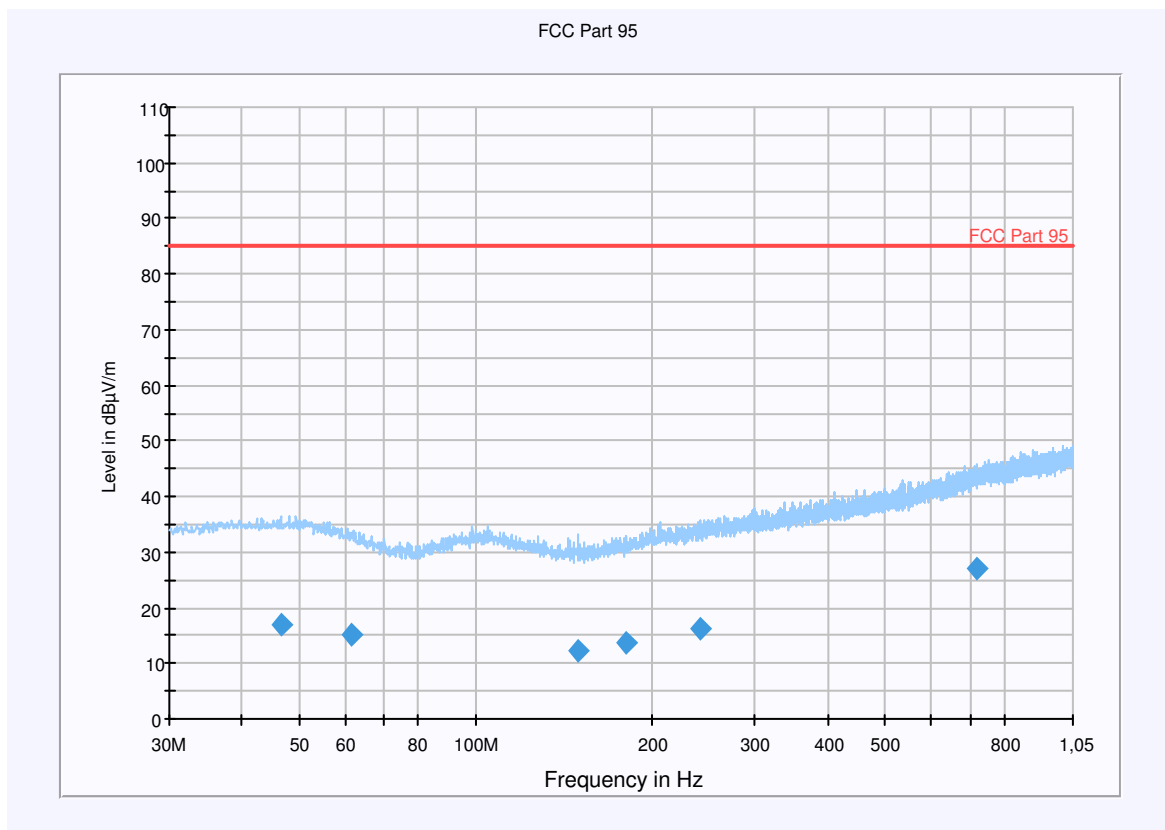

**Final Result 1**

Frequency (MHz)	QuasiPeak (dBµV/m)	Meas. Time (ms)	Bandwidth (kHz)	Antenna height (cm)	Polarity	Turntable position (deg)	Corr. (dB)	Margin (dB)	Limit (dBµV/m)	Comment
46.822500	17.1	15000.000	120.000	333.0	H	67.0	13.3	67.9	85.0	
61.290600	15.2	15000.000	120.000	381.0	V	112.0	11.3	69.8	85.0	
150.358650	12.4	15000.000	120.000	300.0	H	291.0	8.9	72.6	85.0	
181.029000	13.8	15000.000	120.000	365.0	V	-5.0	10.5	71.2	85.0	
241.456350	16.1	15000.000	120.000	181.0	V	305.0	13.1	68.9	85.0	
716.598750	27.0	15000.000	120.000	400.0	V	-5.0	22.9	58.0	85.0	

**Hardware Setup: EMI radiated\Electric Field (NOS) – [EMI radiated]**

Subrange 1

Frequency Range:	30 MHz – 2 GHz
Receiver:	Receiver [ESCI 3] @ GPIB0 (ADR 20), SN 100083/003, FW 4.32
Signal Path:	without Notch FW 1.0
Antenna:	VULB 9163 SN 9163-295, FW --- Correction Table (vertical): VULP6113 Correction Table (horizontal): VULP6113 Correction Table : Cable_EN_1GHz (1005)
Antenna Tower:	Tower [EMCO 2090 Antenna Tower] @ GPIB0 (ADR 8), FW REV 3.12
Turntable:	Turntable [EMCO Turntable] @ GPIB0 (ADR 9), FW REV 3.12

EMC 32 Version 8.10.00

Sample #26

Plot 4: 1 GHz – 12.75 GHz, antenna vertical

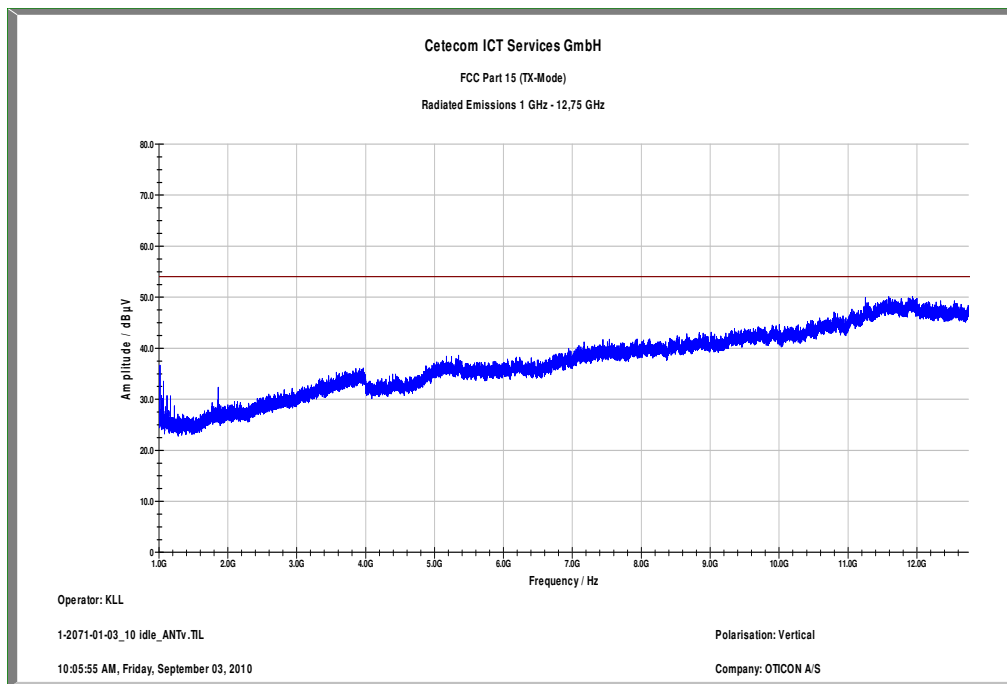

Plot 5: 1 GHz – 12.75 GHz, antenna horizontal

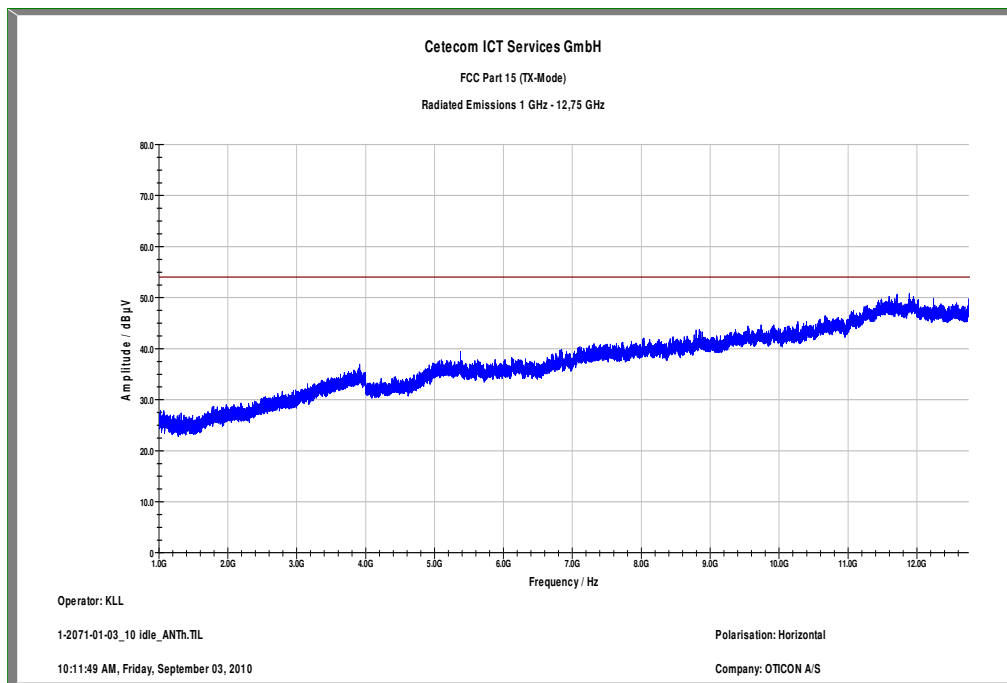

**9.6 Conducted limits**

**Not applicable**

**Measurement:**

Measurement parameter	
Detector:	
Sweep time:	
Resolution bandwidth:	
Video bandwidth:	
Span:	
Trace-Mode:	

**Limits:**

FCC		IC	
SUBCLAUSE § 15.107 / 15.207		-/-	
Conducted limits			
Frequency of Emission (MHz)	Conducted Limit (dBµV)		
	Quasi-peak	Average	
0.15 – 0.5	66 to 56 *	56 to 46 *	
0.5 – 5	56	46	
5 – 30	60	50	

**Result:** -/-.

## 10 Test equipment and ancillaries used for tests

Typically, the calibrations of the test apparatus are commissioned to and performed by an accredited calibration laboratory. The calibration intervals are determined in accordance with the DIN EN ISO/IEC 17025. In addition to the external calibrations, the laboratory executes comparison measurements with other calibrated test systems or effective verifications. Weekly chamber inspections and range calibrations are performed. Where possible, rf-generating and signalling equipment as well as measuring receivers and analyzers are connected to an external high-precision 10 MHz reference (GPS-based or rubidium frequency standard).

In order to simplify the identification of the equipment used at some special tests, some items of test equipment and ancillaries can be provided with an identifier or number in the equipment list below (Labor/Item).

No.	Labor / Item	Equipment	Type	Manufact.	Serial No.	INV. No Cetecom	Kind of Calibration	Last Calibration	Next Calibration
1	n. a.	Signal Analyzer 20Hz-26,5GHz-150 to + 30 DBM	FSIQ26	R&S	835540/018	300002681-0005	k	07.01.2010	07.01.2012
2	n. a.	DC Power Supply 0 – 32V	1108-32	Heiden	001802	300001383	Ve	23.06.2010	23.06.2013
3	n. a.	DC power supply, 60Vdc, 50A, 1200 W	6032A	HP Meßtechnik	2818A03450	300001040	Ve	08.01.2009	08.01.2012
4	n. a.	PowerAttenuator	8325	Byrd	1530	300001595			
5	n. a.	Double-Ridged Waveguide Horn Antenna 1-18.0GHz	3115	EMCO	8812-3088	300001032	viKI!	05.03.2009	05.03.2011
6	n. a.	Active Loop Antenna	6502	EMCO	2210	300001015	ne		
7	n. a.	Anechoic chamber	FAC 3/5m	MWB / TDK	87400/02	300000996		23.03.2009	
8	Spec.A. 2_2e	System rack for EMI measurement solution	85900	HP I.V.	*	300000222	ne		
9	9	Artificial Mains 9 kHz to 30 MHz	ESH3-Z5	R&S	828576/020	300001210	Ve	06.01.2010	06.01.2012
10	n. a.	Relais Matrix	3488A	HP Meßtechnik	2719A15013	300001156	ne		
11	n. a.	Relais Matrix	PSU	R&S	890167/024	300001168	ne		
12	n. a.	Isolating Transformer	RT5A	Grundig	9242	300001263	ne		
13	n. a.	Three-Way Power Splitter, 50 Ohm	11850C	HP Meßtechnik		300000997	ne		
14	n. a.	Switch / Control Unit	3488A	HP	2605e08770	300001443	ne		
15	n. a.	Band Reject filter	WRCG1855/1910-1835/1925-40/8SS	Wainwright	7	300003350	ev		
16	n. a.	Band Reject filter	WRCG2400/2483-2375/2505-50/10SS	Wainwright	11	300003351	ev		
17	n. a.	TILE-Software Emission	Quantum Change, Modell TILE-ICS/FULL	EMCO	none	300003451	ne		
18	n. a.	Highpass Filter	WHKX2.9/18G-12SS	Wainwright	1	300003492	ev		
19	n. a.	Highpass Filter	WHK1.1/15G-10SS	Wainwright	3	300003255	ev		
20	n. a.	Highpass Filter	WHKX7.0/18G-8SS	Wainwright	18	300003789	ne		
21	n. a.	PSA Spectrum Analyzer 3 Hz – 26.5 GHz	E4440A	Agilent Technologies	MY48250080	300003812	k		
22	n. a.	MXG Microwave Analog Signal Generator	N5183A	Agilent Technologies	MY47420220	300003813	k		
23	n. a.	RF Filter Section 9kHz – 1GHz	N9039A	Agilent Technologies	MY48260003	300003825	viKI!		
24	n. a.	TRILOG Broadband Test-Antenna 30 MHz	VULB9163	Schwarzbeck	371	300003854	viKI!	17.12.2008	17.12.2010



		- 3 GHz							
25	45	Switch-Unit	3488A	HP Meßtechnik	2719A14505	300000368	g		
26	50	DC power supply, 60Vdc, 50A, 1200 W	6032A	HP Meßtechnik	2920A04466	300000580	k	06.01.2009	06.01.2011
27	n. a.	software	SPS_PHE 1.4f	Spitzberger & Spieß	B5981; 5D1081;B5979	300000210	ne		
28	n. a.	EMI Test Receiver	ESCI 1166.5950.03	R&S	100083	300003312	k	08.01.2010	08.01.2012
29	n. a.	Analyzer- Reference- System (Harmonics and Flicker)	ARS 16/1	SPS	A3509 07/0 0205	300003314	k	01.06.2009	01.06.2011
30	n. a.	Amplifier	JS42-00502650- 28-5A	MITEQ	1084532	300003379	ev		
31	n. a.	Antenna Tower	Model 2175	ETS- LINDGREN	64762	300003745	izw		
32	n. a.	Positioning Controller	Model 2090	ETS- LINDGREN	64672	300003746	izw		
33	n. a.	Turntable Interface-Box	Model 105637	ETS- LINDGREN	44583	300003747	izw		
34	n. a.	TRILOG Broadband Test- Antenna 30 MHz - 3 GHz	VULB9163	Schwarzbeck	295	300003787	k	01.04.2010	01.04.2012
35	n. a.	Spectrum- Analyzer	FSU26	R&S	200809	300003874	k	08.01.2010	08.01.2012
36	n. a.	Test Receiver ESH2	n. a.	R&S	871921/095	300002505	k	02/2010	02/2012
37	n. a.	Loop Antenna HFH2-Z2	n. a.	R&S	872096/61	300001824	k	11/2009	11/2011

## Agenda: Kind of Calibration

k calibration / calibrated  
 ne not required (k, ev, izw, zw not required)  
 ev periodic self verification  
 Ve long-term stability recognized  
 vlk! Attention: extended calibration interval  
 NK! Attention: not calibrated

EK limited calibration  
 zw cyclical maintenance (external cyclical maintenance)  
 izw internal cyclical maintenance  
 g blocked for accredited testing  
 \*) next calibration ordered / currently in progress

**Annex A Document history**

Version	Applied changes	Date of release
1.0	Initial release	2010-11-05
-A	FCC-ID corrected	2010-11-11
-B	Without photos	2010-11-15
-C	Page 8 + Page 12 typing error (value of field strength/max. power)	2010-11-17

**Annex B Further information****Glossary**

DUT	-	Device under Test
EMC	-	Electromagnetic Compatibility
EUT	-	Equipment under Test
FCC	-	Federal Communication Commission
FCC ID	-	Company Identifier at FCC
HW	-	Hardware
IC	-	Industry Canada
Inv. No.	-	Inventory number
N/A	-	not applicable
S/N	-	Serial Number
SW	-	Software