



TRaC Global  
100 Frobisher Business Park,  
Leigh Sinton Road  
Malvern,  
Worcestershire,  
WR14 1BX,  
UK

Date 18<sup>th</sup> December, 2012

## TYOJN5168U0 – Operational Description

### Radio

The figure below shows the single ended radio architecture and frequency generating scheme used in the JN5168 chip:

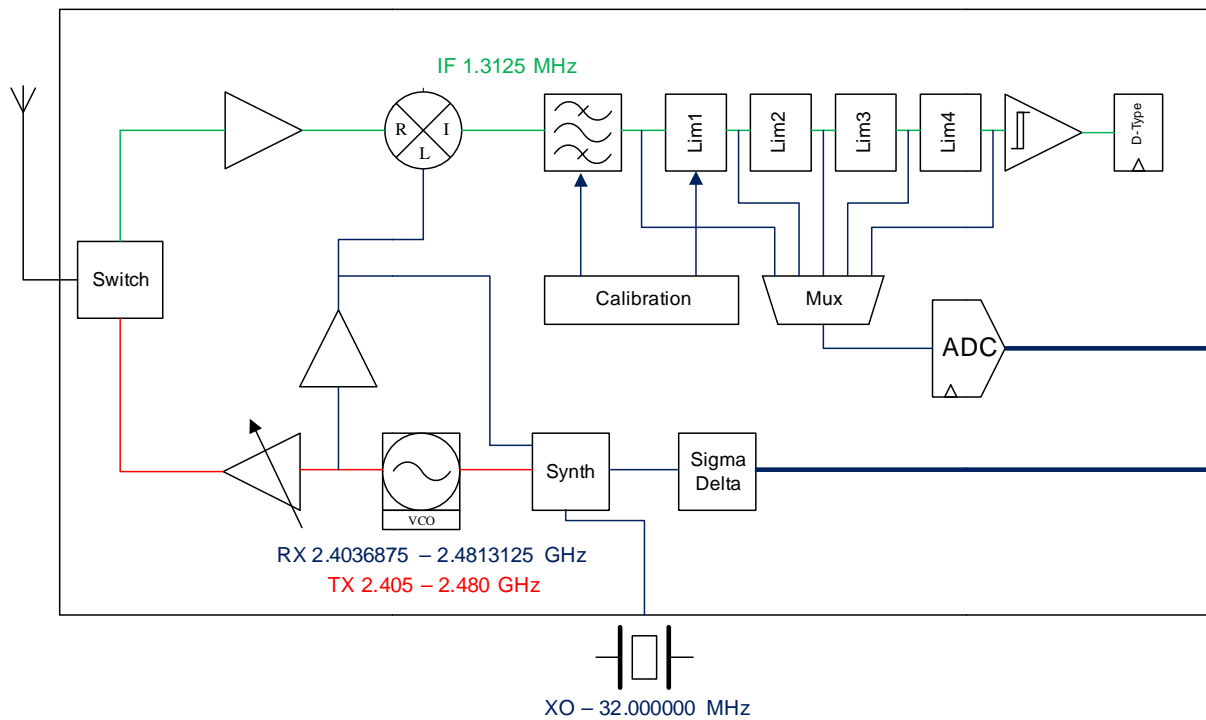

Figure 1: Radio Architecture

The radio comprises a low-IF receive path and a direct modulation transmit path, which converge at the TX/RX switch. The switch connects to the external single ended matching network, which consists of two inductors and a capacitor, this arrangement creates a 50Ω port and removes the need for a balun. A 50Ω single ended antenna can be connected directly to this port.



The 32MHz crystal oscillator feeds a divider, which provides the frequency synthesiser with a reference frequency. The synthesiser contains programmable feedback dividers, phase detector, charge pump and internal Voltage Controlled Oscillator (VCO). The VCO has no external components, and includes calibration circuitry to compensate for differences in internal component values due to process and temperature variations. The VCO is controlled by a Phase Locked Loop (PLL) that has an internal loop filter. A programmable charge pump is also used to tune the loop characteristic.

The receiver chain starts with the low noise amplifier/mixer combination whose outputs are passed to a low pass filter, which provides the channel definition. The signal is then passed to a series of amplifier blocks forming a limiting strip. The signal is converted to a digital signal before being passed to the Modem. The gain control for the RX path is derived in the automatic gain control (AGC) block within the Modem, which samples the signal level at various points down the RX chain. To improve the performance and reduce current consumption, automatic calibration is applied to various blocks in the RX path.

In the transmit direction, the digital stream from the Modem is passed to a digital sigma-delta modulator which controls the feedback dividers in the synthesiser, (dual point modulation). The VCO frequency now tracks the applied modulation. The 2.4 GHz signal from the VCO is then passed to the RF Power Amplifier (PA), whose power control can be selected from one of three settings. The output of the PA drives an external Skyworks Front End Module which houses an LNA, PA and necessary RF switching as shown in figure 2 the module block diagram.

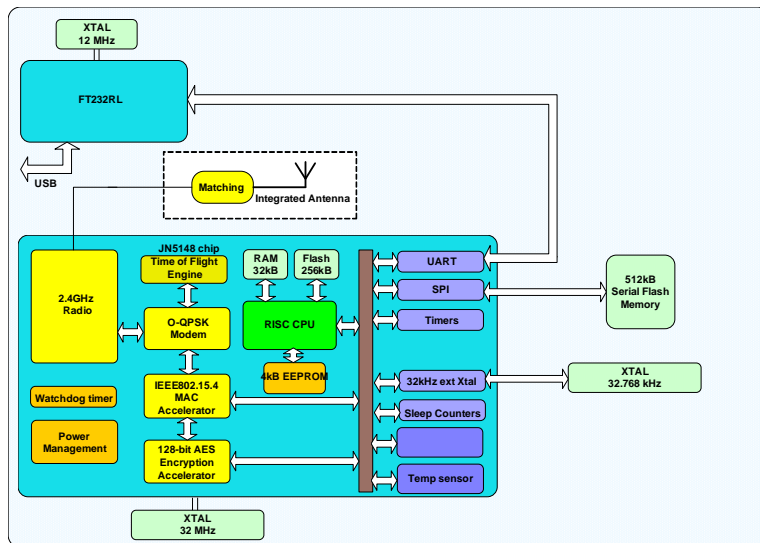

Figure 2: Dongle Block diagram