

Figure 16.3 — Lateral surface of retro-reflection material on EPIRB S2=6.88 cm²

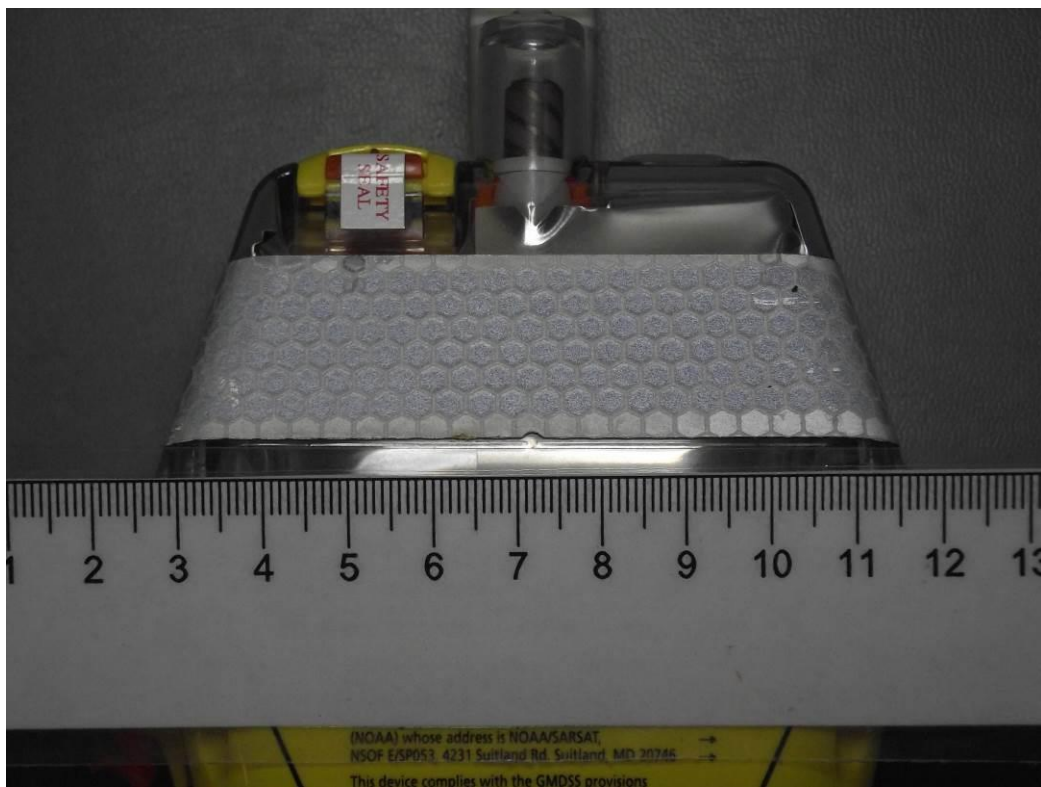

Figure 16.4 — The reverse side of retro-reflection material on EPIRB S3=6.44 cm²

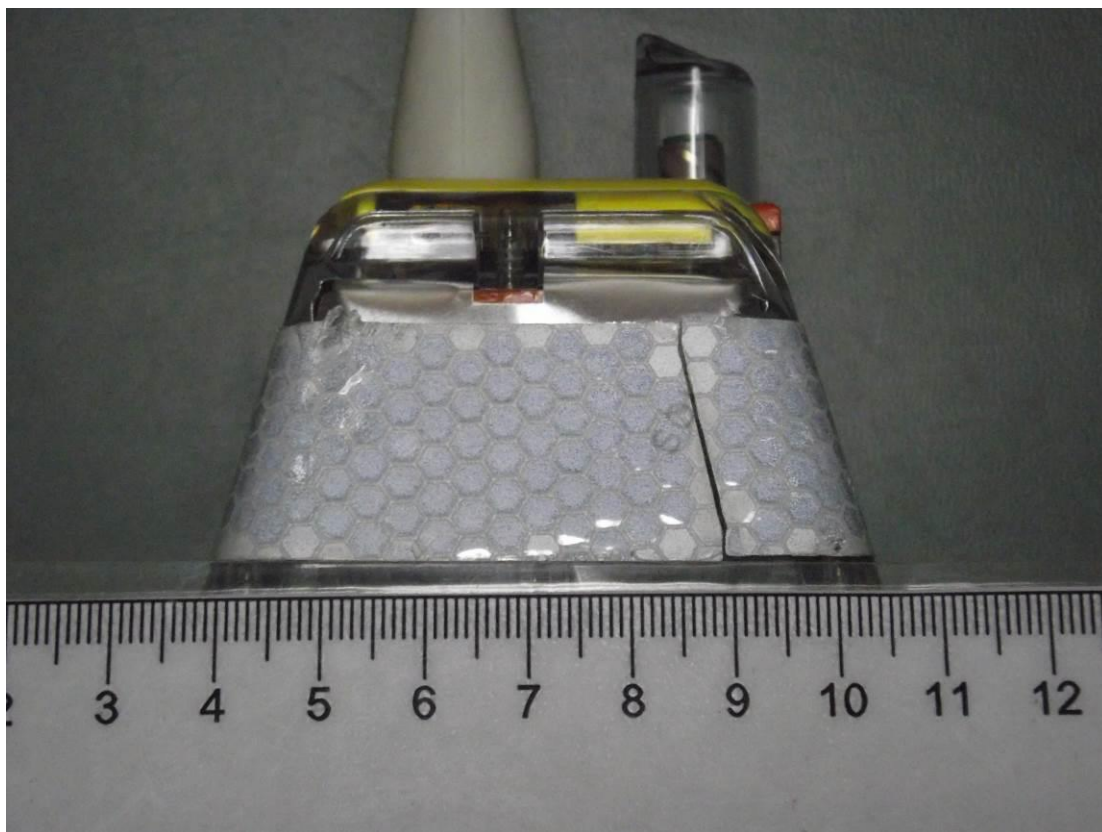

Figure 16.5 — Lateral surface of retro-reflection material on EPIRB S4=9.63 cm²

ANNEX 17.
LANYARD CHECK

Equipment Under Test (EUT): MT603FG

SW version: OS0021 ver 1.00 (8/12/2014)

Test Date: 18.04.16

Test Conditions:

- Ambient temperature: 19.3 °C
- Relative humidity: 49%
- Atmospheric pressure: 755mm/Hg

TEST PROGRAM

No	Test name	Requirements	Methods
1.	Lanyard Check	A.2.1, 3.3.6 IEC 61097-2	5.3.6 IEC 61097-2

TEST DESCRIPTION:

The satellite EPIRB shall be equipped with a buoyant lanyard, firmly attached to it, suitable for use as a tether for survivors or from a survival craft in the water. It is so arranged as to prevent its being trapped in the ship's structure when floating free. The buoyant lanyard shall have a length of 5 m to 8 m. The breaking strength of the lanyard and its attachment to the satellite EPIRB shall be at least 25 kg.

TEST RESULT

Passed

TEST DETAILS

Parameter	Result	Comment	Conclusion
Length of the lanyard check	5.37 m	By measurement	Pass
The breaking strength check	25,57 kg	By inspection ¹⁾	Pass

Note ¹⁾ Manufacturersubmitted own test report as evidence that lanyard meets this requirement according with item 5.3.6 of standard IEC 61097-2.



Figure 17.1 - Length of the lanyard 5.37 m



Figure 17.2 - Attaching of the lanyard



Figure 17.3 – View of the lanyard on the MT603FG



Figure 17.4 – Checking buoyancy of the lanyard



Figure 17.5 – Test installation

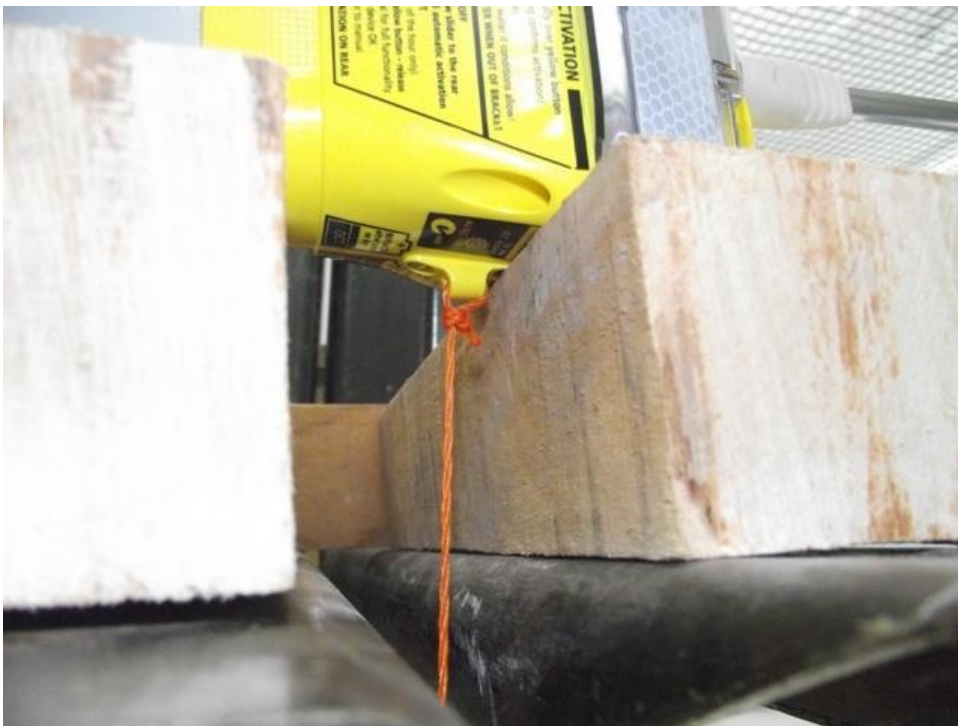

Figure 17.6 – Checking buoyancy of the lanyard

TEST EQUIPMENT USED

No	Name of test equipment	Type, model	ser. No	Calibration Due date
1	Set of buoyancy	-	101173	01.2018
2	Scale	CAS AD-10H	60400410	12.2016
3	Ruler	Lineyka-1000	64	03.2018
4	Ruler	P5Y3Д (S-Line)	23	11.2016

ANNEX 18.
STABILITY AND BUOYANCY TEST

Equipment Under Test (EUT): MT603FG

SW version: OS0021 ver 1.00 (8/12/2014)

Test Date: 19.04.16

Test Conditions:

- Ambient temperature: 20.9 °C
- Atmospheric pressure: 753 mm/Hg
- Relative air humidity: 57 %

TEST PROGRAM

No	Test name	Requirements	Methods
1	Stability and buoyancy test	A.2.3, 3.3.2 b) IEC 61097-2	5.3.2.2 IEC 61097-2

TEST DESCRIPTION

With the antenna deployed in its normal operating position, the EUT should, when rotated to a horizontal position about any axis, submerged just below the surface, and released, pass through an upright position within 2 seconds. The EUT should float upright in calm fresh water with the base of the antenna a minimum of 40 mm above the water-line.

The reserve buoyancy of the satellite EUT (EPIRB) should be at least 5% when determined by the following procedure:

Submerge the complete unit and measure the buoyant force with a scale.

Divide the measured buoyant force by the weight of the unit. The result should be at least 0.05.

TEST RESULT

Passed

TEST DETAILS

When released from submerged in horizontal position, EUT passed through an upright position within 1.2 s.

In calm fresh water EUT floats upright with the base of the antenna 44 mm above the water-line.

Buoyancy force: 1.47 N (i.e. 0.150 kg)

EUT weight: 0.556 kg

Thus, reserve buoyancy is:

$$0.150 / 0.55 = 0.269$$

Test result is presented in table below.

Parameters	Range of Specification	Test results
High of antenna base above the water-line	> 40 mm	78 mm
Stability	< 2 s	1.22 s
Reserve buoyancy	> 5 %	27 %



Figure 18.1 – Buoyancy test



Figure 18.2 – Measuring of distance from water level to the base of antenna while EUT floating in calm fresh water



Figure 18.3 – Measuring of buoyant force



Figure 18.4 – Dynamometer

TEST EQUIPMENT

No	Name of test equipment	Type, model	ser. No	Calibration Due date
1	Set of buoyancy	-	101173	01.2018
2	Set of stability	-	101175	05.2016
3	Scale	CAS AD-10H	60400410	12.2016
4	Dynamometer	Г25-150	13465	12.2016
5	Ruler	Lineyka-1000	64	03.2018

ANNEX 19.
PREVENTION TO INADVERTENT ACTIVATION

Equipment Under Test (EUT): 1) MT603G
2) MT603FG

SW version: OS0021 ver 1.00 (8/12/2014)

Test Date: 18.04.2016

Test Conditions:

- Ambient temperature: 23 °C
- Atmospheric pressure: 753 mm/Hg
- Relative air humidity: 54 %

TEST PROGRAM

No	Test name	Requirements	Methods
1	Prevention of inadvertent activation	A.2.1, 3.3.1 a) IEC 61097-2	5.3.1, 5.5.1.1 IEC 61097-2

TEST DESCRIPTION

The EUT was mounted on the rotatable support and fixed as it is described in the user's manual. A stream from a hose was directed at the EUT for a period of 5 min. The nozzle of the hose has a nominal diameter of 63.5 mm and a water-delivery rate of 2300 liters of water per minute. The end of the nozzle was 3.50 m away from the EUT and 1.50 m above the base of the antenna. EUT was rotated during the test, so that water strikes the EUT in an arc of 180° perpendicular to the normal mounting position of the EUT.

TEST RESULT

Passed.

TEST DETAILS

EPIRB was not released from its release mechanism. EPIRB was not automatically activated as a result of the water from the hose stream.



Figure 19.1 – EUT (MT603G) mounted on the rotatable support before test.



Figure 19.2 – EUT (MT603FG) mounted on the rotatable support before test.

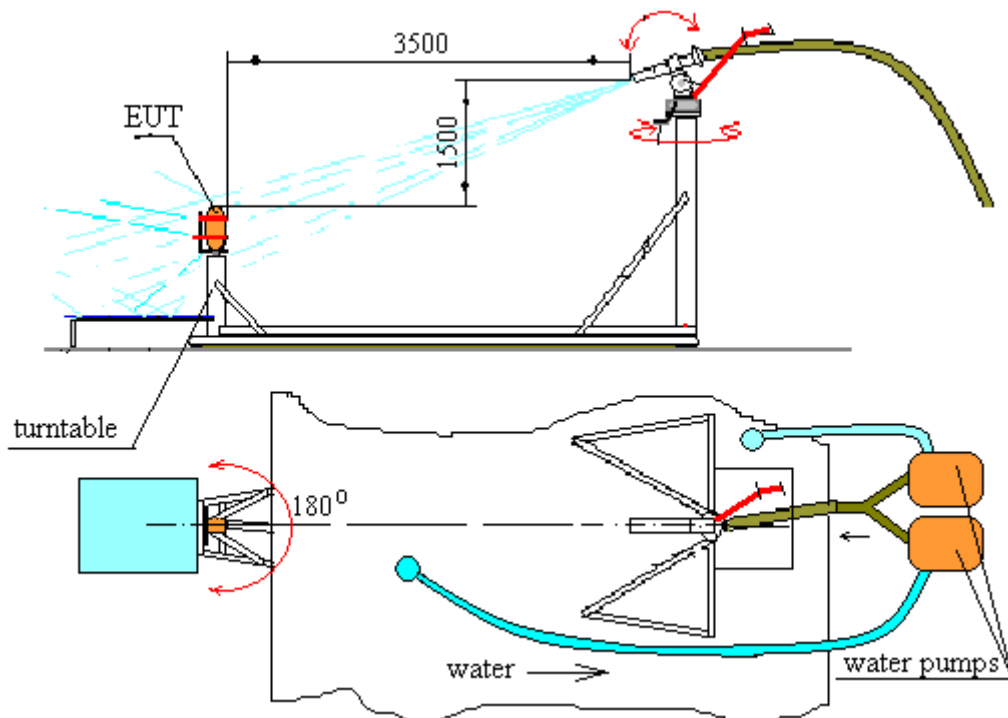



Figure 19.3 – General view of the test setup MT603G



Figure 19.4 – General view of the test setup MT603FG



Figure 19.5 - The water strikes EUT (MT603G) in an arc of 180°.



Figure 19.6 - The water strikes EUT (MT603FG) in an arc of 180°.



Figure 19.7 - View of EUT (MT603G) upon completion of inadvertent activation test



Figure 19.8 - View of EUT (MT603FG) upon completion of inadvertent activation test

Parameter	Conclusion
MT603G is fitted with adequate means to prevent inadvertent activation an deactivation	Passed
MT603G was not released from release mechanism. MT603G was not inadvertently activated.	Passed
MT603FG is fitted with adequate means to prevent inadvertent activation an deactivation	Passed
MT603FG was not released from release mechanism. MT603FG was not inadvertently activated.	Passed

TEST EQUIPMENT

No	Name of test equipment	Type, model	ser. No	Calibration Due date
1	Beacon tester	BT-611	1005	11.2016
2	Installation of water washing	-	101174	04.2018
3	Stopwatch	SOSpr-2b-2	2388	10.2018

ANNEX 20.
121.5 MHz HOMING DEVICETESTS

Equipment Under Test (EUT): MT603G

SW version: OS0021 ver 1.00 (8/12/2014)

Test Date: 18.05.16

Test Conditions:

– Temperature

Minimum: -20 °C

Maximum: +55 °C

Ambient: +20°C

TEST PROGRAM

Item	Test name	Requirements	Methods
1	121.5 MHz auxiliary radio-locating device transmitter test	D.3 IEC 61097-2	Annex D IEC 61097-2

TEST DESCRIPTION

1. Carrier Frequency Test

The carrier frequency test was performed with a spectrum analyzer. The carrier frequency measured at the minimum and maximum operating temperatures.

2. Modulation Characteristics

The transmitter duty cycle, modulation frequency, modulation duty cycle, modulation factor and sweep repetition rate were determined by observing the detected RF signal with a storage oscilloscope. The frequency coherence test was performed with a spectrum analyzer.

All measurements were made at the minimum and maximum operating temperatures.

3. Peak Effective Radiated Power

The elevation angle between 5° and 20° which produces a maximum gain was determined with the EUT at an arbitrary azimuth. The peak envelope power was measured and the elevation angle was noted and should remain fixed for the remainder of the test. The remaining 11 measurements of the peak effective radiated power were obtained by rotating the EUT in increments of 30° ± 3°. For each measurement the EUT peak effective radiated power (PERP) was computed using the following equation:

$$PEIRP = LOG^{-1} \frac{P_{REC} - G_{REC} + L_C + L_P}{10},$$

Where:

P_{REC} – Measured Power level from spectrum analyzer (dBm);

G_{REC} – Antenna gain of search antenna (dB);

L_C – Receive system attenuator and cable loss (dB);

L_P – Free space propagation loss (dB).

4. Off ground plane radiated power test

This test is effectively a repeat of the peak effective radiated power test except that the satellite EPIRB is raised off the ground plane.

The measurement procedure included a determination of four values of PERP made by direct measurement of radiated power. Four measurements were taken every 90° ± 3° in azimuth. The four azimuth PERP measurements were made at the same elevation angle; the elevation used was the angle between 5° and 20° for which the EUT exhibits a maximum antenna gain.

– StepNo. 1

Carrier Frequency Test(D.3 a)

Condition: The carrier frequency was measured at the minimum and maximum operating temperatures.

– Step No. 2

Transmitter Duty Cycle(D.3 c)

Condition: During the observation of the transmitted signal the carrier was not interrupted (except for up to two seconds during transmission of the 406 MHz pulse).

– Step No. 3

Modulation Characteristics(D.3 d)

Condition for Modulation Frequency and Sweep Repetition Rate Measurement: During the observation of the modulation envelope the upper and lower audio-frequency sweep limits and sweep repetition rate were measured.

– Step No. 4

Modulation Characteristics(D.3 d)

Condition for Modulation Duty Cycle Measurement: The modulation duty cycle was measured near the start, midpoint, and end of the modulation sweep period. Modulation duty cycle was calculated using the following formula

$$\text{Duty Circle} = \frac{A}{B} \times 100\%$$

– Step No. 5

Modulation Characteristics(D.3 d)

Condition for Modulation Factor Measurement: The modulation factor was defined with respect to the maximum and minimum amplitudes of the modulation envelope, by the following formula

$$\text{Modulation Factor} = \frac{A - B}{A + B}$$

– Step No. 6

Modulation Characteristics(D.3 d)

Condition for Frequency Coherence Measurement:

The measurement was made for the total power emitted during any transmission cycle with or without modulation.

The measurement was made to define the carrier frequency shift after interruption by the transmission of the 406 MHz burst.

– Step No. 7

Peak Effective Radiated Power (D.3 b)

Condition for Peak Effective Radiated Power Measurement: This test was performed at ambient temperature for the EUT whose battery had been ON for a minimum of 44 hours.

The test site was positioned on the ground with uniform electrical characteristics. The site was clear of metal objects, overhead wires, etc., and was as free as possible from undesired signals such as ignition noise or other RF carriers. The distance from the EUT, or the search antenna to reflecting objects was more than 30 m. The EUT was placed in the center of a ground plane with a radius of 75 cm ± 5 cm mounted on the ground level. The EUT was positioned vertically such that the ground plane was at the nominal waterline. The ground plane was resting on the ground and extended so that it completely enclosed and presented a snug fit to the below waterline portion of the EUT.

Measurement of the radiated signals was made at a point 10 m from the EUT. At this point, a wooden pole or insulated tripod with a movable horizontal boom was arranged. The search antenna was raised and lowered through an elevation angle of 5° to 20°. It was mounted on the end of the boom with its cable lying horizontally on the boom and run back to the supporting mast. The other end of the search antenna cable was connected to a spectrum analyzer located at the foot of the mast.

Note. The PERP measurement was performed on OATS which is compliant with CISPR requirements.

– Step No. 8

Off ground plane radiated power test (D.4.3)

Condition for off ground plane radiated Power Measurement: This test was performed at ambient temperature for the EUT whose battery had been ON for a minimum of 44 hours.

The test site was the same as used in C/S T.007 Figure B.5 except that the distance between the Beacon Under Test and the RF Receiver was 10 m (not 3 m). The RFAM material was positioned such that the centre of the 3.6 m by 2.4 m section of RFAM was positioned at the specular reflection point for the ground reflected path signal between the EUT and the spectrum analyzer positioned at the elevation angle between 5° and 20° for which the EUT exhibits a maximum an-

tenna gain. The EUT was mounted on a nonconductive wooden stand that raised the height of the base of the EUT 450 mm \pm 25 mm above ground level.

The method of measurement was the same as in Step No.6 except that only 4 azimuth measurements were made at 90° \pm 3° intervals.

TEST RESULT

Minimum Operating Temperature

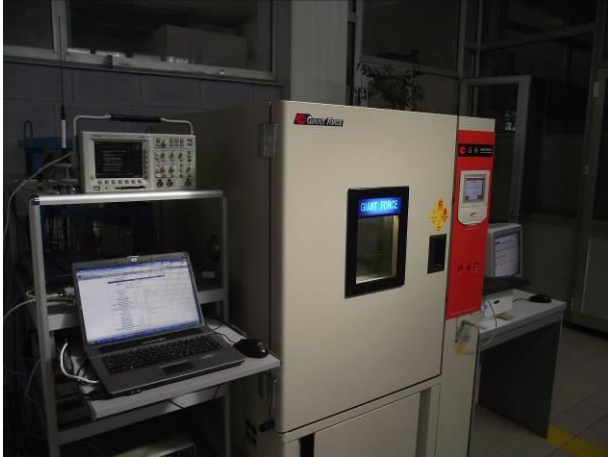

Figure 20.1 – Site for Carrier Frequency Test and Modulation Characteristic Measurement at the minimum, ambient and maximum operating temperatures

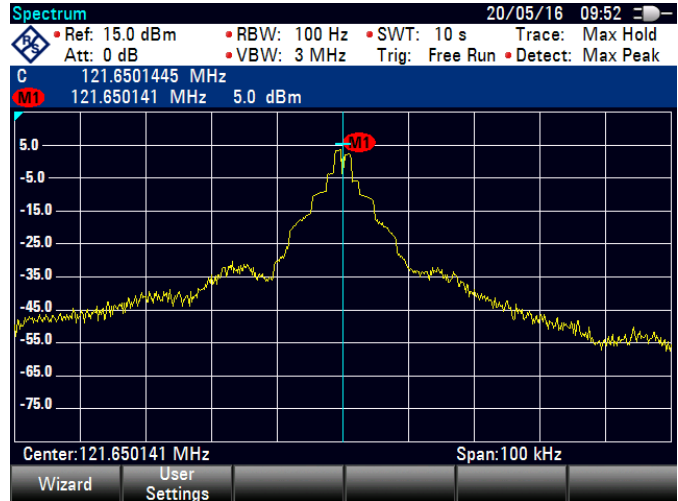

Figure 20.2 – Screenshot of Carrier Frequency Test Result at the minimum operating temperature

Frequency Coherence Measurement Test Result:

- (i) Set the spectrum analyzer controls as follows:
- I.F. bandwidth: 10 kHz
 - Video filter: OFF or as wide as possible
 - Scan time: 100 ms./div.
 - Amplitude scale: 5 dB/div.
 - Scan width: 10 kHz/div.
 - Center frequency: 121.5 MHz
- (ii) Record the amplitude in dBm. (Figure 20.3)

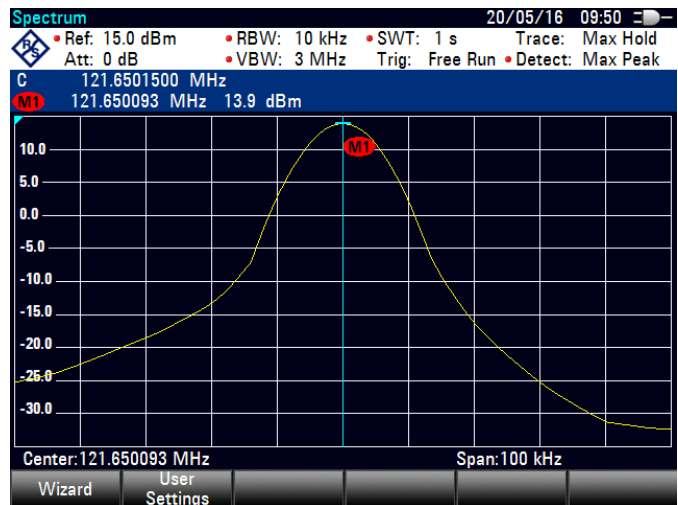

Figure 20.3 – Screenshot of Frequency Coherence Measurement Test Result (transmitted power at wide band) at the minimum operating temperature

(iii) Calculate the mean output power by adding 10 log(D), where D is the modulation duty cycle determined below, to the recorded signal level.

(iv) Set the spectrum analyzer controls as follows:

- I.F. bandwidth: 60 Hz or less
- Video filter: OFF or as wide as possible
- Scan time: 10 sec/div
- Amplitude scale: 0.5 dB/div
- Scan width: 20 Hz/div
- Center frequency: 121.5 MHz

(v) Measure and record the carrier power dBm as displayed on the spectrum analyzer (Figure 20.4).

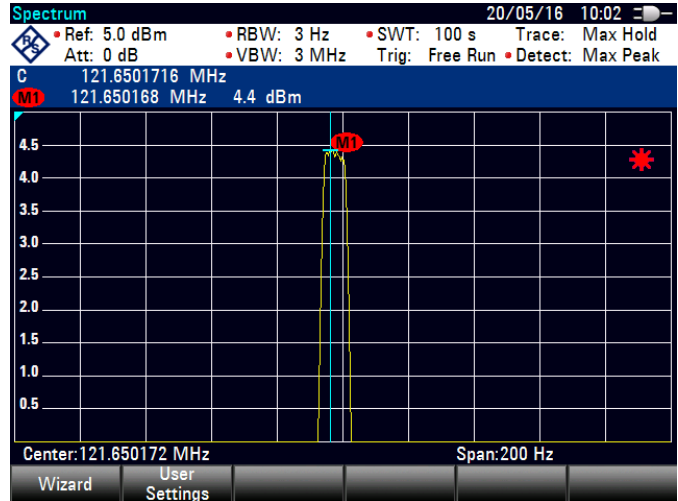

Figure 20.4 – Screenshot of Frequency Coherence Measurement Test Result (transmitted power at narrow band) at the minimum operating temperature

(vi) Calculate the ratio of carrierpower to mean power from steps (iii) and (v) using the following formula:

$$\frac{\text{Carrier_power}}{\text{Mean_power}} = 10^{\frac{\text{dB}_C - \text{dB}_{\text{mean}}}{10}}$$

dB_C = carrier power in step (v)

dB_{mean} = mean power in step (iii)

TEST RESULTS

Output power measurement at the antenna connector as persteps (i)and (ii) is 13.9dBm.

Mean power calculated as perstep (iii) is 13.9 + 10log(D), where D is the modulationduty cycle. In the worst case D is 32.00%, therefore mean power is 13.9 + 10 log(0.32) = 8.95dBm

Carrier power that measured with 3 Hz I.F. bandwidth is 5dBm.

Ratio of carrierpower to mean power is 40.27 %.

$$\frac{\text{Carrier_power}}{\text{Mean_power}} = 10^{\frac{\text{dB}_C - \text{dB}_{\text{mean}}}{10}} = 10^{\frac{5 - 8.95}{10}} = 0.4027$$

Carrier power is below of the mean power by 3.95dB.

40.27% of the total power is shown to be within ±3Hz of the carrier frequency.

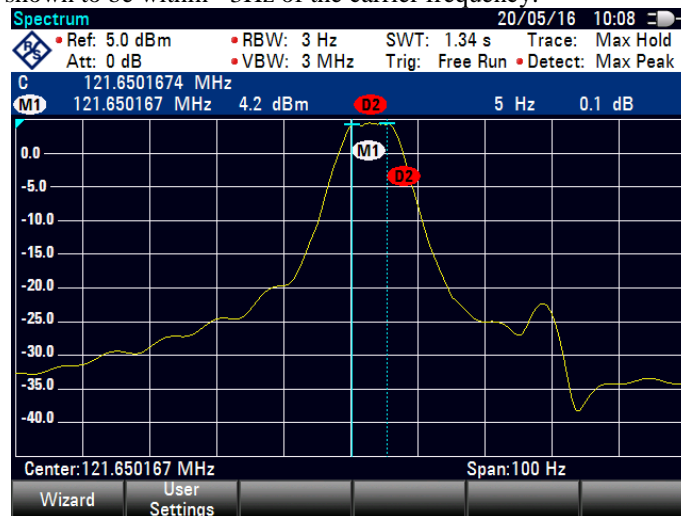

Figure 20.5 – Screenshot of Frequency Coherence Measurement Test Result (Frequency Shift) at the minimum operating temperature. Transmitted RF (121.5 MHz) before the interruption for the 406 MHz RF burst (M1) and after the interruption for the 406 MHz RF burst (D2)

The carrier frequency does not vary by more than $\pm 5\text{Hz}$ during the interruption for a 406MHz transmission. See Figures 20.5.

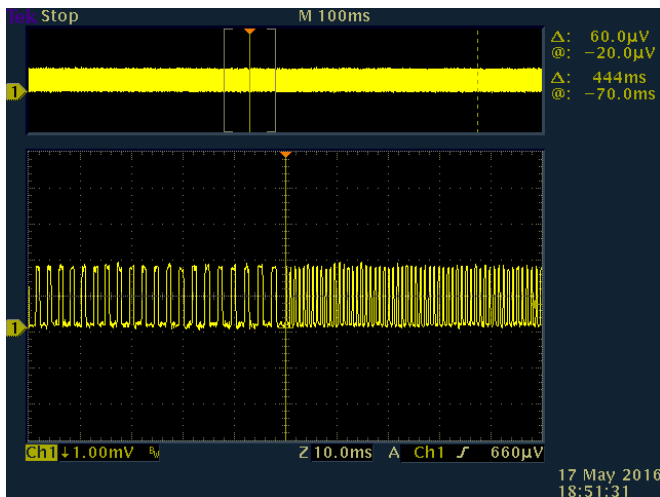

Figure 20.6 – Screenshot of Sweep repetition rate Test Result at the minimum operating temperature

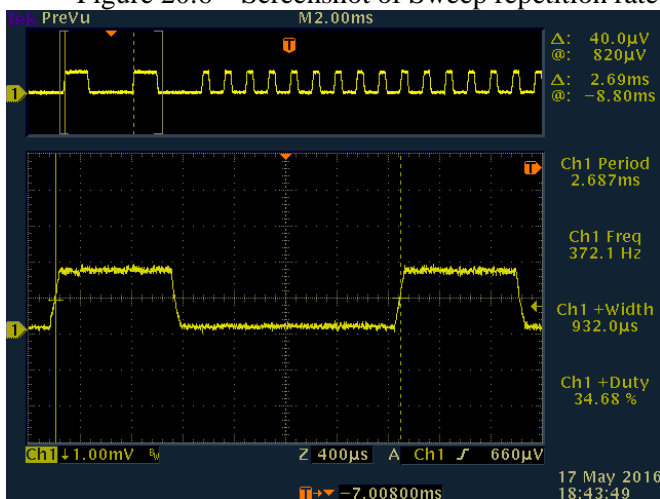
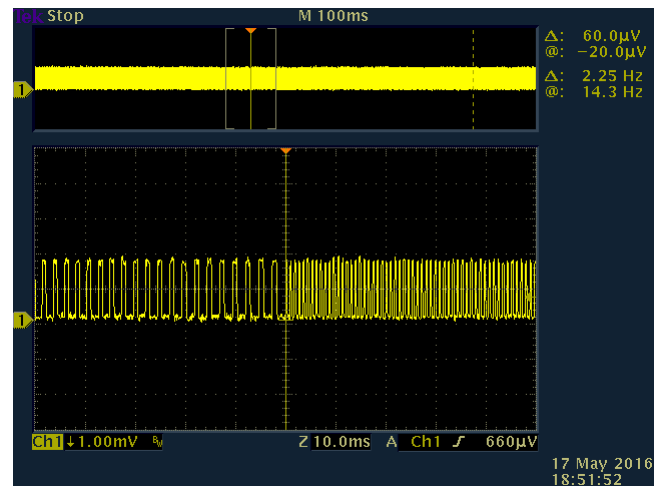

Figure 20.7 – Screenshot of Demodulation Waveform (A) measured start of the modulation sweep period at the minimum operating temperature

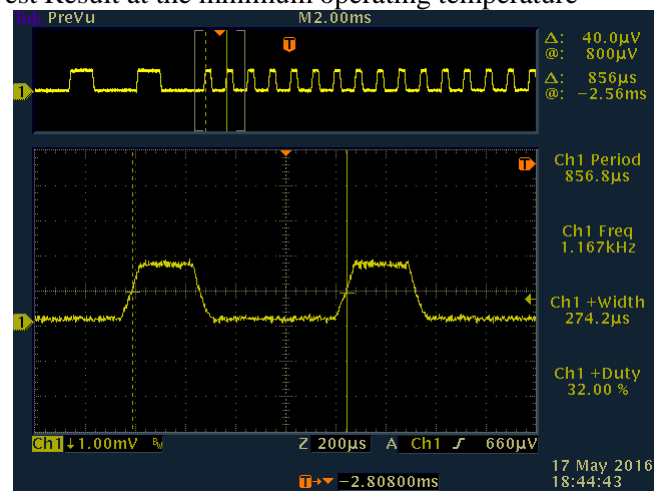

Figure 20.8 – Screenshot of Demodulation Waveform (A) measured near midpoint of the modulation sweep period at the minimum operating temperature

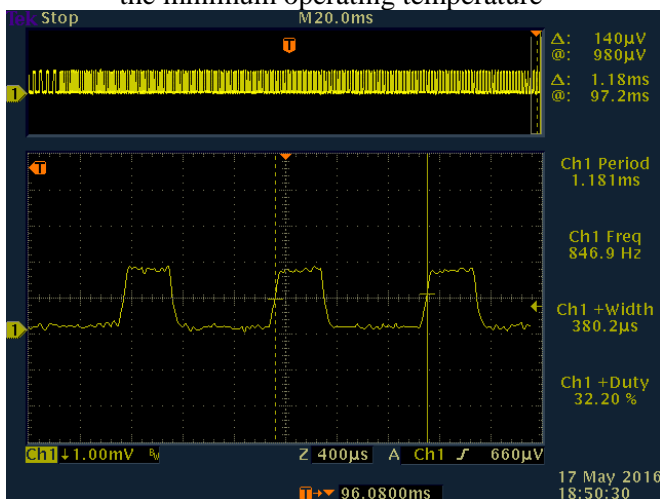

Figure 20.9 – Screenshot of Demodulation Waveform (A) measured near end of the modulation sweep period at the minimum operating temperature

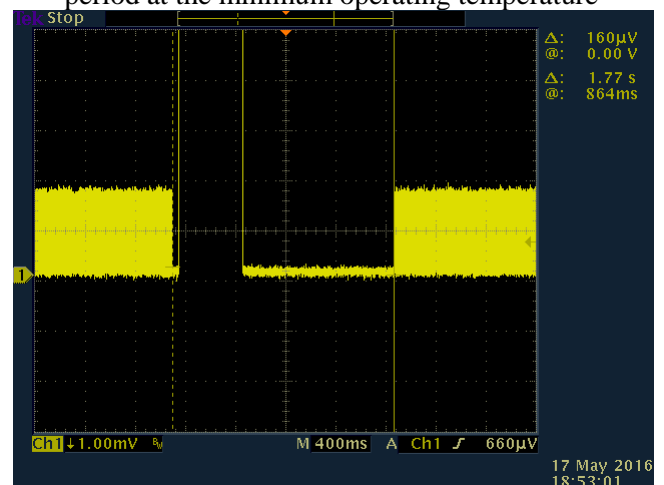

Figure 20.10 – Screenshot of Transmitter Duty Cycle Test Result at the minimum operating temperature

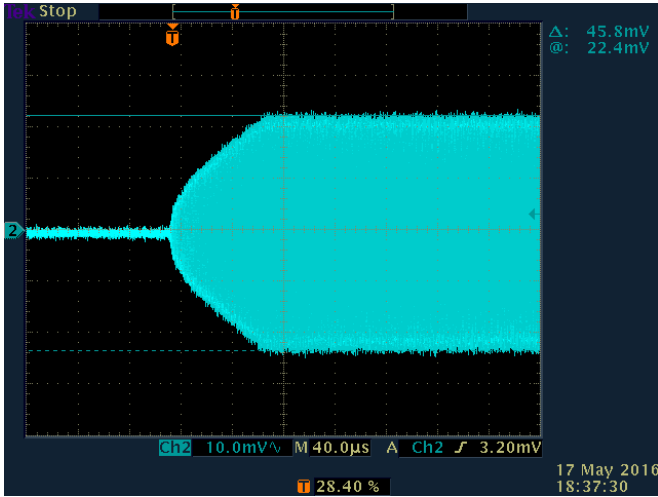

Figure 20.11 – Screenshot of maximum amplitude signal for determination of the Modulation Factor at the minimum operating temperature

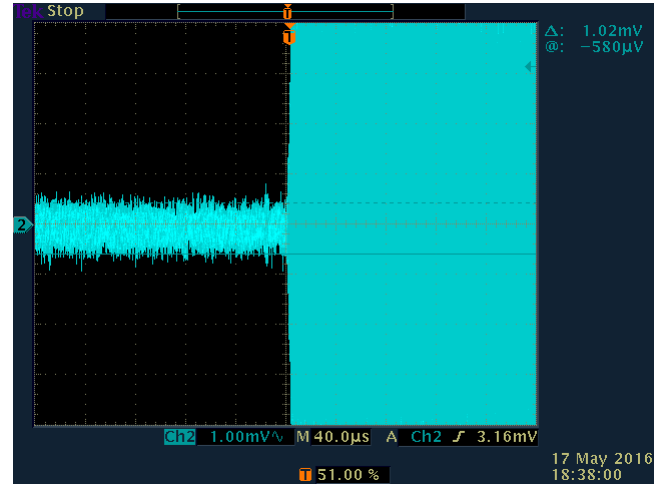

Figure 20.12 – Screenshot of minimum amplitude signal for determination the Modulation Factor at the minimum operating temperature

$$Modulation\ Factor = \frac{A - B}{A + B} = \frac{45.8 - 1.02}{45.8 + 1.02} = 95.27\%$$

Maximum Temperature

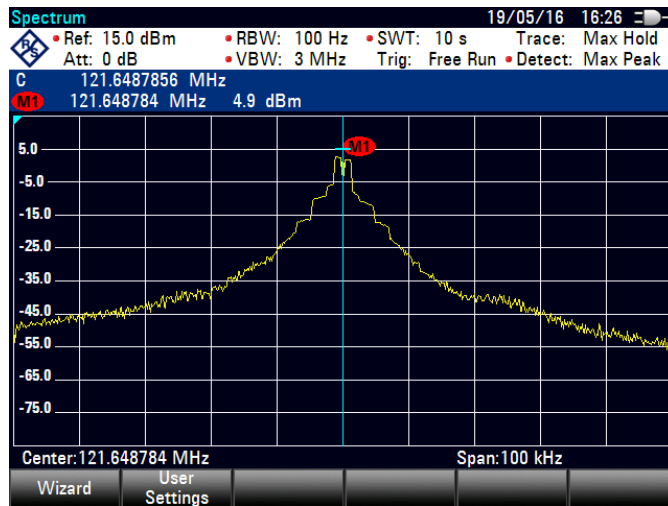

Figure 20.13 – Screenshot of Carrier Frequency Test Result at the maximum operating temperature

Frequency Coherence Measurement Test Result:

(i) Set the spectrum analyzer controls as follows:

- I.F. bandwidth: 10 kHz
- Video filter: OFF or as wide as possible
- Scan time: 100 ms./div.
- Amplitude scale: 5 dB/div.
- Scan width: 10 kHz/div.
- Center frequency: 121.5 MHz

(ii) Record the amplitude in dBm. (Figure 20.14)

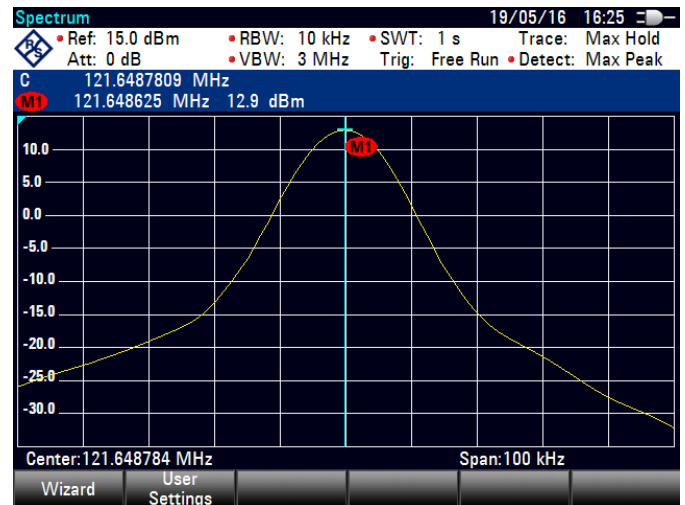

Figure 20.14 – Screenshot of Frequency Coherence Measurement Test Result (transmitted power at wide band) at the maximum operating temperature

(iii) Calculate the mean output power by adding 10 log(D), where D is the modulation duty cycle determined below, to the recorded signal level.

(iv) Set the spectrum analyzer controls as follows:

- I.F. bandwidth: 60 Hz or less
- Video filter: OFF or as wide as possible
- Scan time: 10 sec/div
- Amplitude scale: 0.5 dB/div
- Scan width: 20 Hz/div
- Center frequency: 121.5 MHz

(v) Measure and record the carrier power dBm as displayed on the spectrum analyzer (Figure 20.15).

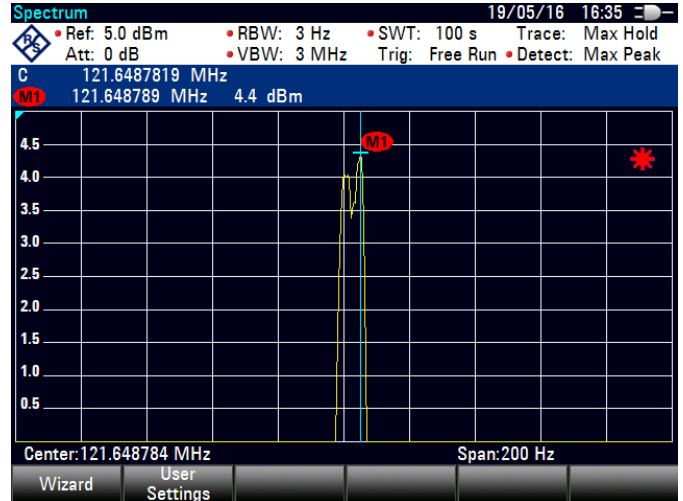

Figure 20.15 – Screenshot of Frequency Coherence Measurement Test Result (transmitted power at narrow band) at the maximum operating temperature

(vi) Calculate the ratio of carrier power to mean power from steps (iii) and (v) using the following formula:

$$\frac{\text{Carrier_power}}{\text{Mean_power}} = 10^{\frac{\text{dBc-dBmean}}{10}}$$

dB_C = carrier power in step (v)

dB_{mean} = mean power in step (iii)

TEST RESULTS

Output power measurement at the antenna connector as per steps (i) and (ii) is 12.9dBm.

Mean power calculated as perstep (iii) is 12.9 + 10log(D), where D is the modulation duty cycle. In the worst case D is 36.41%, therefore mean power is 12.9 + 10 log(0.3641) = 8.51dBm

Carrier power that measured with 3 Hz I.F. bandwidth is 4.9dBm.

Ratio of carrier power to mean power is 43.55%.

$$\frac{\text{Carrier_power}}{\text{Mean_power}} = 10^{\frac{\text{dBc-dBmean}}{10}} = 10^{\frac{4.9-8.51}{10}} = 0.4355$$

Carrier power is below of the mean power by 3.61dB.

43.55% of the total power is shown to be within ±3Hz of the carrier frequency.

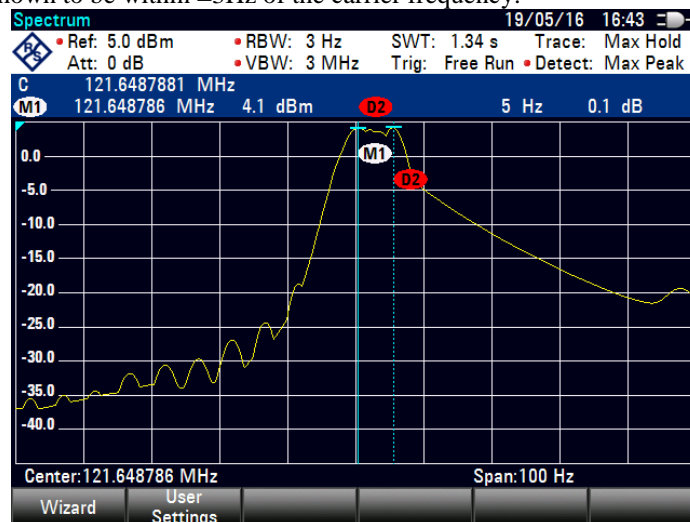

Figure 20.16 – Screenshot of Frequency Coherence Measurement Test Result (Frequency Shift) at the maximum operating temperature. Transmitted RF (121.5 MHz) before the interruption for the 406 MHz RF burst (M1) and after the interruption for the 406 MHz RF burst (D2)

The carrier frequency does not vary by more than $\pm 5\text{Hz}$ during the interruption for a 406 MHz transmission. See Figures 20.16.

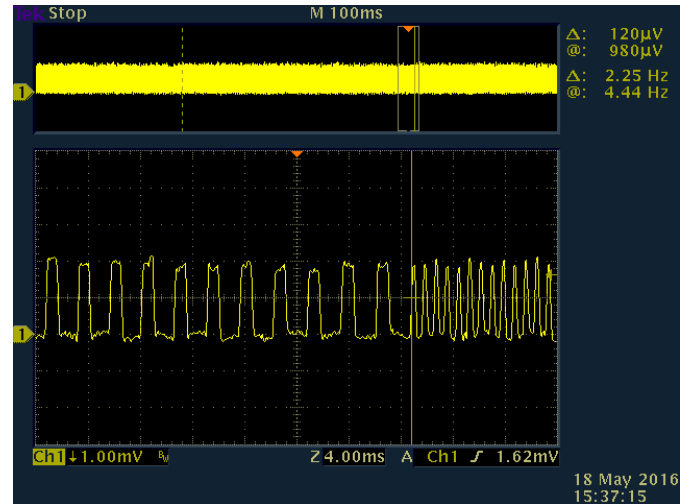
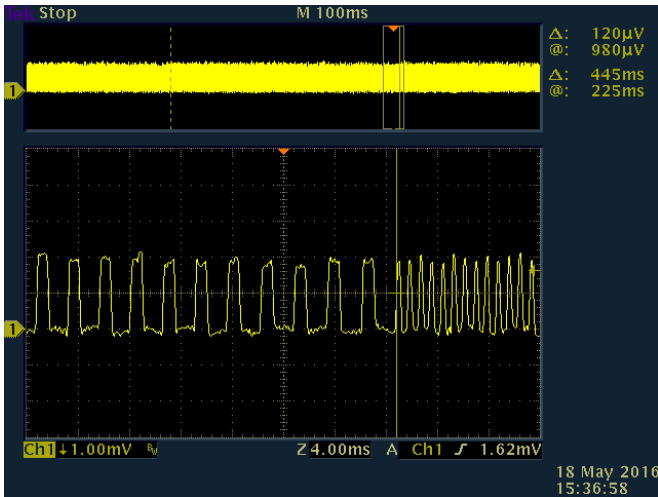

Figure 20.17 – Screenshot of Sweep repetition rate Test Result at the maximum operating temperature

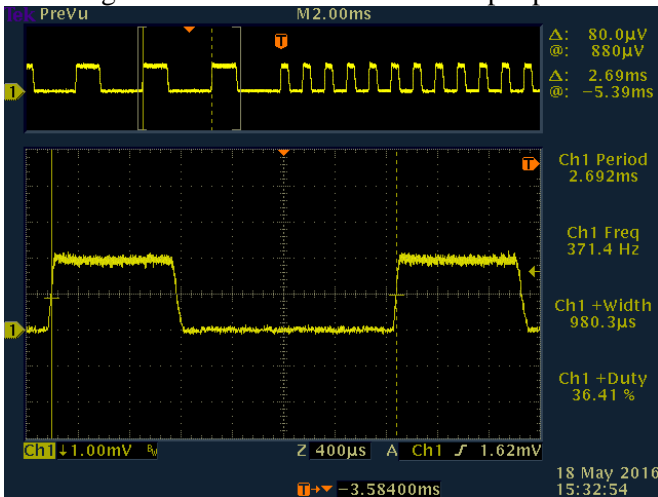

Figure 20.18 – Screenshot of Demodulation Waveform (A) measured start of the modulation sweep period at the maximum operating temperature

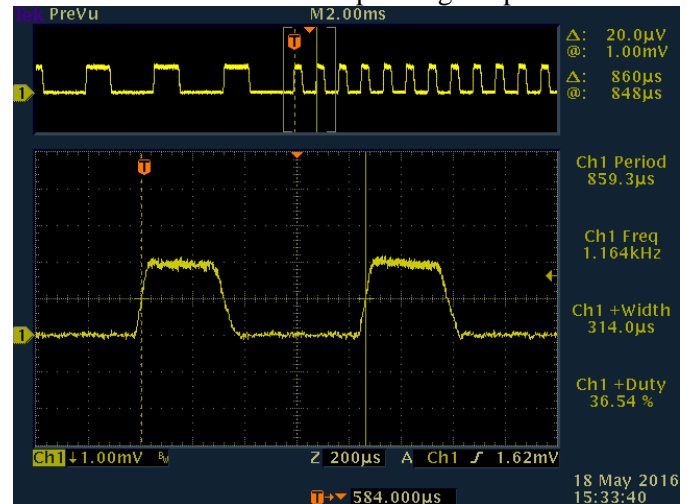

Figure 20.19 – Screenshot of Demodulation Waveform (A) measured near midpoint of the modulation sweep period at the maximum operating temperature

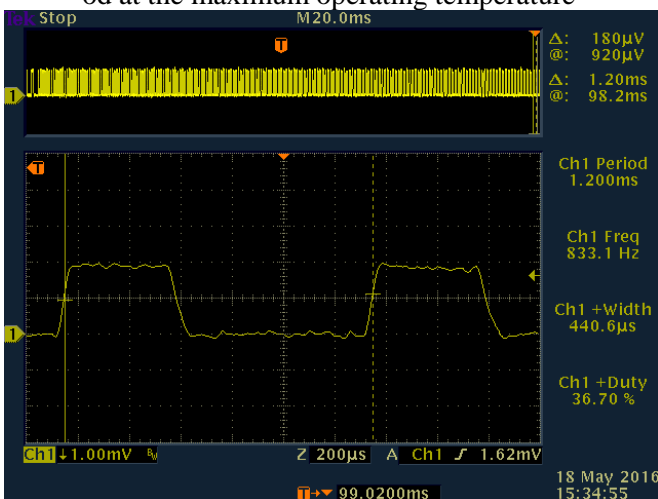

Figure 20.20 – Screenshot of Demodulation Waveform (A) measured near end of the modulation sweep period at the maximum operating temperature

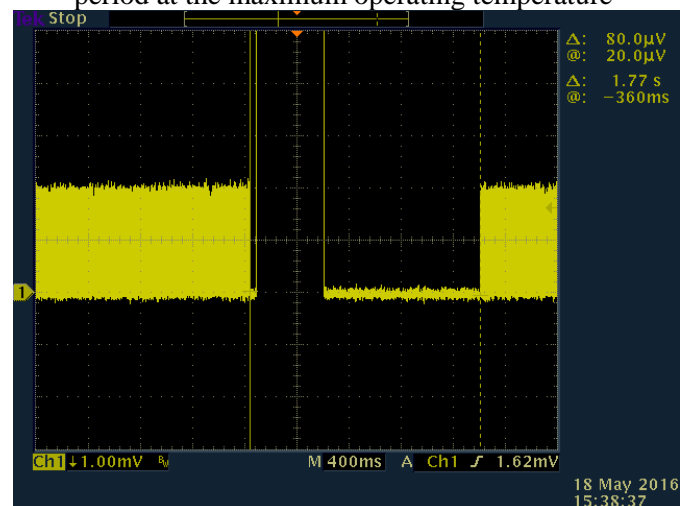

Figure 20.21 – Screenshot of Transmitter Duty Cycle Test Result at the maximum operating temperature

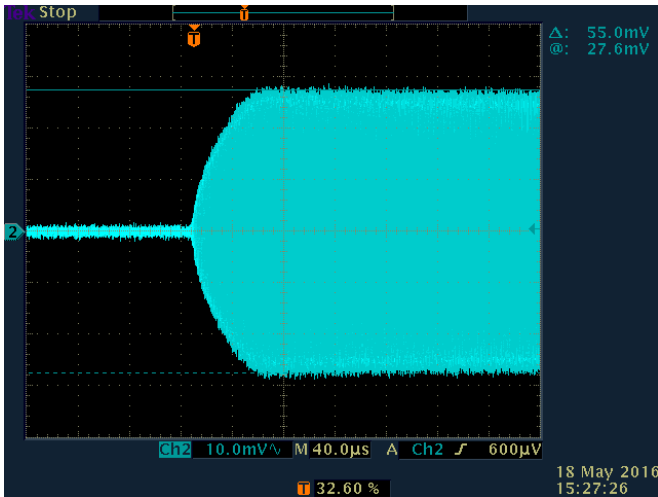

Figure 20.22 – Screenshot of maximum amplitude signal for determination of the Modulation Factor at the maximum operating temperature

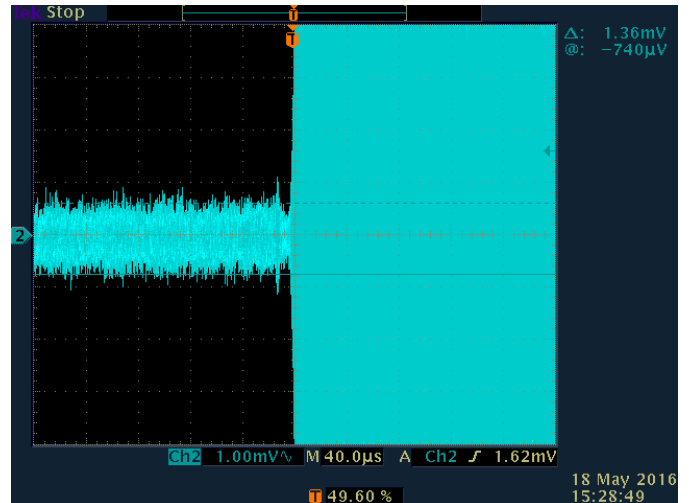

Figure 20.23 – Screenshot of minimum amplitude signal for determination the Modulation Factor at the maximum operating temperature

$$Modulation\ Factor = \frac{A - B}{A + B} = \frac{55.0 - 1.36}{55.0 + 1.36} = 95.17\%$$

Ambient Temperature

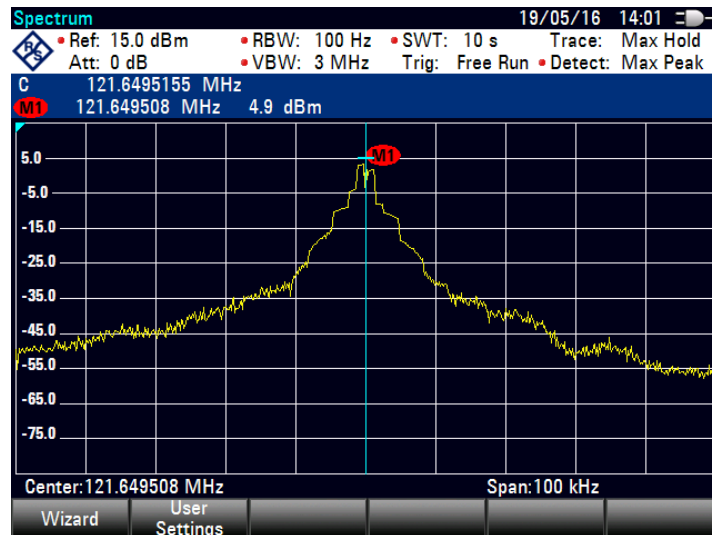

Figure 20.24 – Screenshot of Carrier Frequency Test Result at the ambient operating temperature

Frequency Coherence Measurement Test Result:

(i) Set the spectrum analyzer controls as follows:

- I.F. bandwidth: 10 kHz
- Video filter: OFF or as wide as possible
- Scan time: 100 ms/div.
- Amplitude scale: 5 dB/div.
- Scan width: 10 kHz/div.
- Center frequency: 121.5 MHz

(ii) Record the amplitude in dBm. (Figure 20.25)

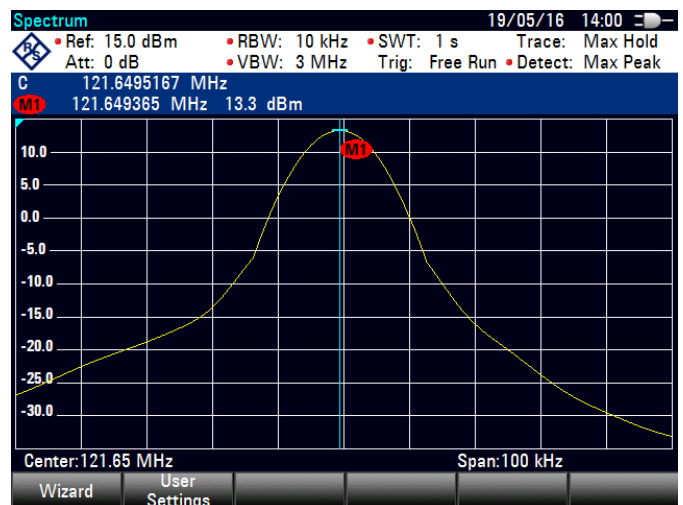

Figure 20.25 – Screenshot of Frequency Coherence Measurement Test Result (transmitted power at wide band) at the ambient operating temperature

(iii) Calculate the mean output power by adding 10 log(D), where D is the modulation duty cycle determined below, to the recorded signal level.

(iv) Set the spectrum analyzer controls as follows:

- I.F. bandwidth: 60 Hz or less
- Video filter: OFF or as wide as possible
- Scan time: 10 sec/div
- Amplitude scale: 0.5 dB/div
- Scan width: 20 Hz/div
- Center frequency: 121.5 MHz

(v) Measure and record the carrier power dBm as displayed on the spectrum analyzer (Figure 20.26).

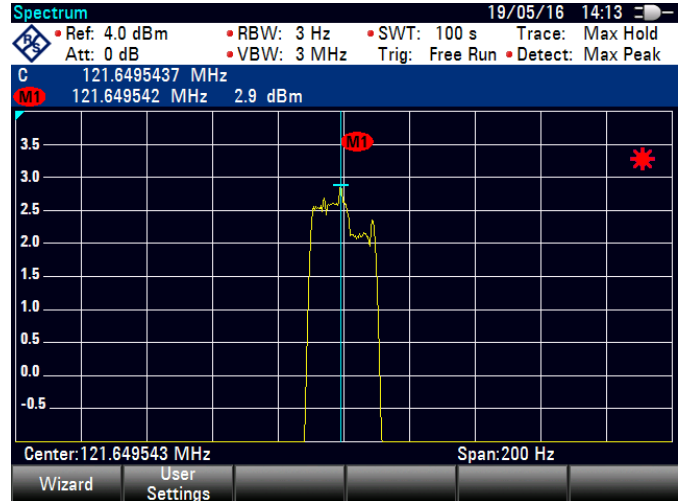

Figure 20.26 – Screenshot of Frequency Coherence Measurement Test Result (transmitted power at narrow band) at the ambient operating temperature

(vi) Calculate the ratio of carrier power to mean power from steps (iii) and (v) using the following formula:

$$\frac{\text{Carrier_power}}{\text{Mean_power}} = 10^{\frac{\text{dB}_C - \text{dB}_{\text{mean}}}{10}}$$

dB_C = carrier power in step (v)

dB_{mean} = mean power in step (iii)

TEST RESULTS

Output power measurement at the antenna connector as per steps (i) and (ii) is 13.3dBm.

Mean power calculated as perstep (iii) is 13.3 + 10log(D), where D is the modulation duty cycle. In the worst case D is 34.02%, therefore mean power is 13.3 + 10log(0.3402) = 8.62dBm

Carrier power that measured with 3 Hz I.F. bandwidth is 4.9dBm.

Ratio of carrier power to mean power is 34.28 %.

$$\frac{\text{Carrier_power}}{\text{Mean_power}} = 10^{\frac{\text{dB}_C - \text{dB}_{\text{mean}}}{10}} = 10^{\frac{4,9 - 8,62}{10}} = 0.4246$$

Carrier power is below of the mean power by 3.72dB.

42.46% of the total power is shown to be within ±3Hz of the carrier frequency.

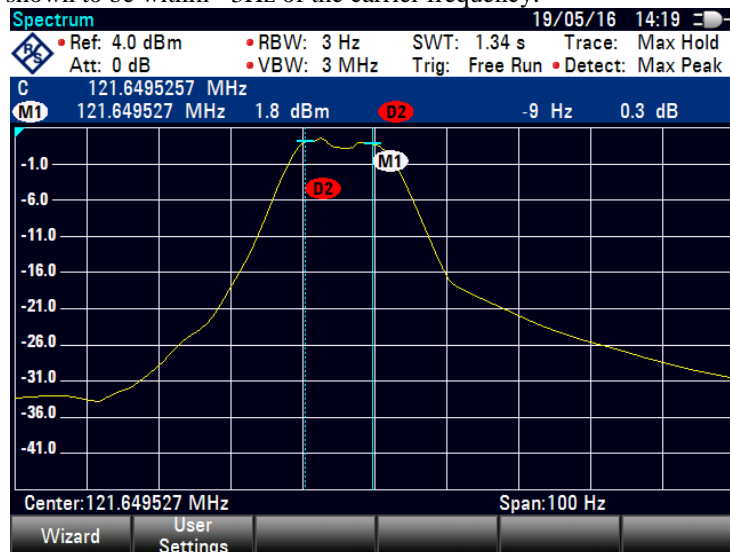

Figure 20.27 – Screenshot of Frequency Coherence Measurement Test Result (Frequency Shift) at the ambient operating temperature. Transmitted RF (121.5 MHz) before the interruption for the 406 MHz RF burst (M1) and after the interruption for the 406 MHz RF burst (D2)

The carrier frequency does not vary by more than $\pm 5\text{Hz}$ during the interruption for a 406 MHz transmission. See Figures 20.27.

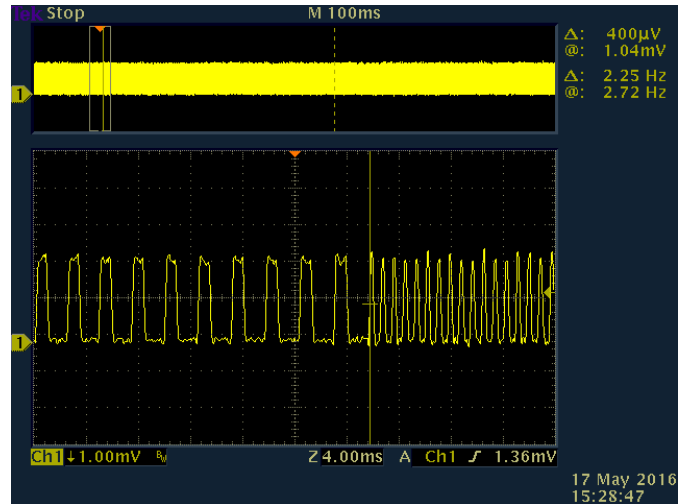
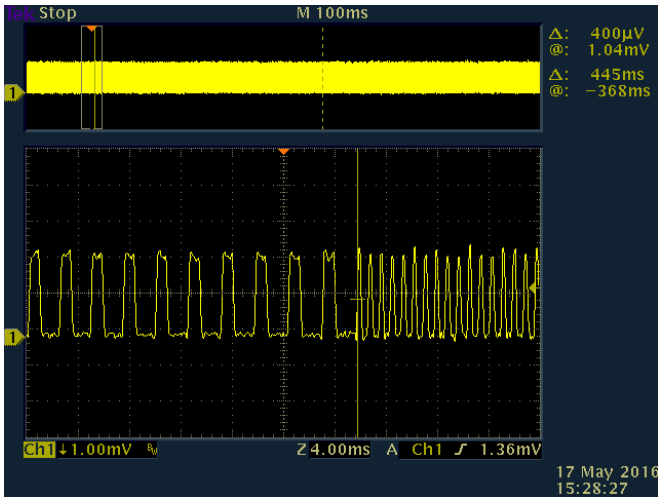

Figure 20.28 – Screenshot of Sweep repetition rate Test Result at the ambient operating temperature

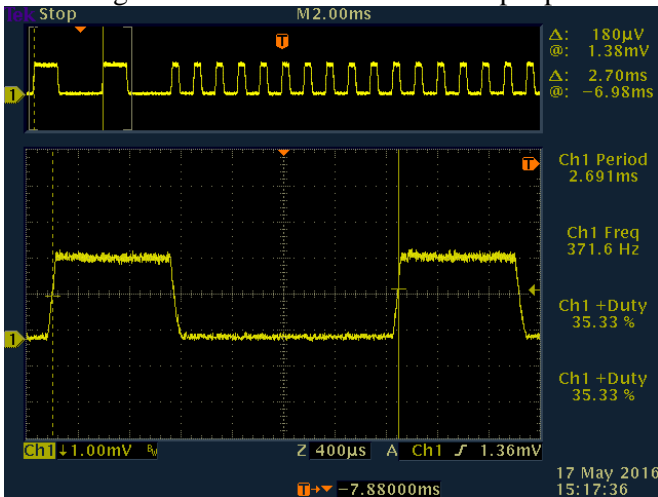

Figure 20.29 – Screenshot of Demodulation Waveform (A) measured start of the modulation sweep period at the ambient operating temperature

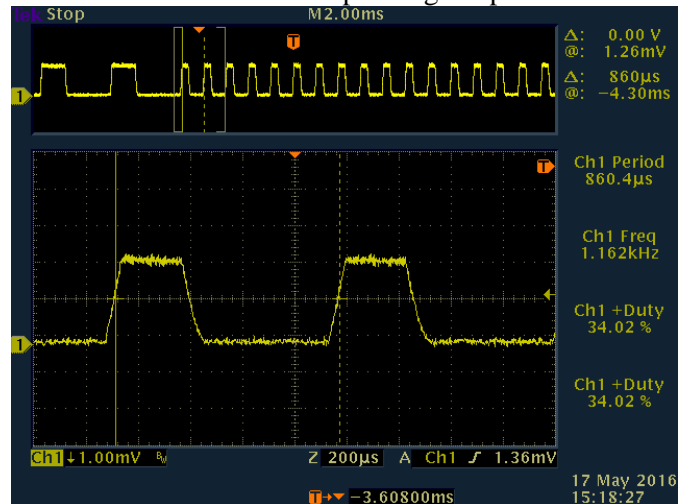

Figure 20.30 – Screenshot of Demodulation Waveform (A) measured near midpoint of the modulation sweep period at the ambient operating temperature

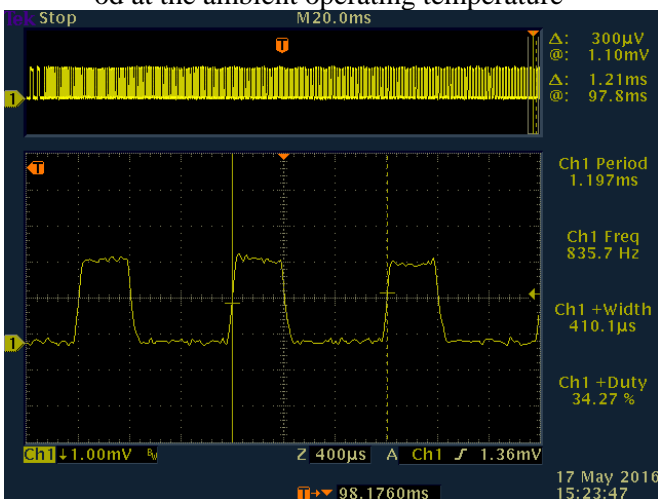

Figure 20.31 – Screenshot of Demodulation Waveform (A) measured near end of the modulation sweep period at the ambient operating temperature

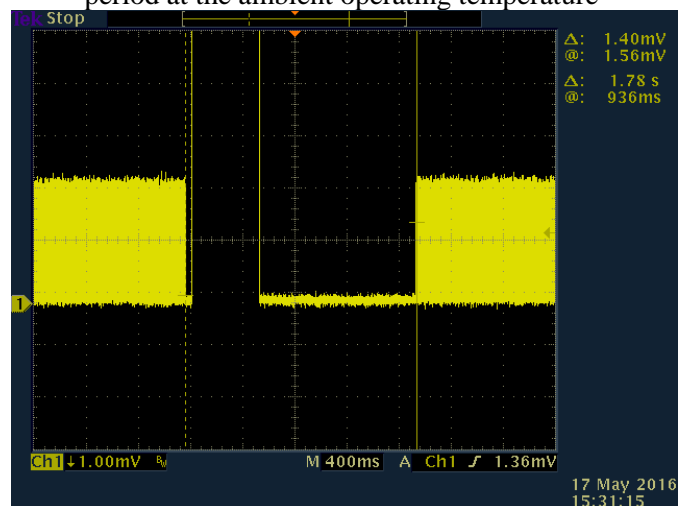

Figure 20.32 – Screenshot of Transmitter Duty Cycle Test Result at the ambient operating temperature

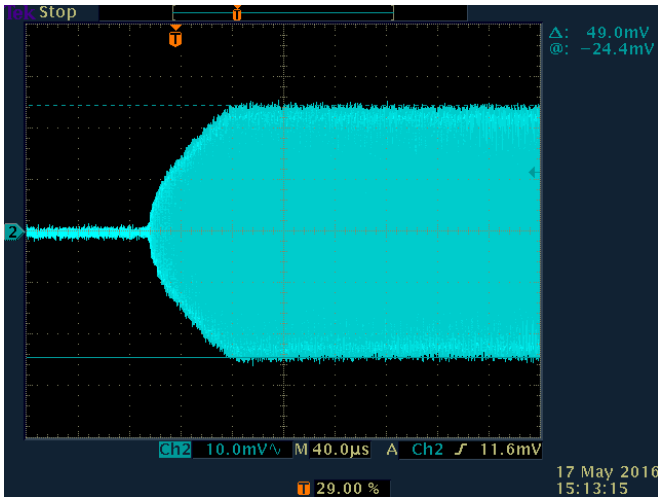

Figure 20.33 – Screenshot of maximum amplitude signal for determination of the Modulation Factor at the ambient operating temperature

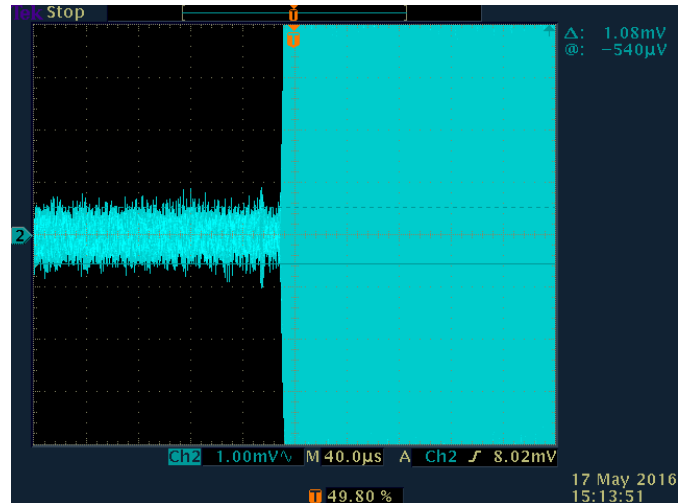

Figure 20.34 – Screenshot of minimum amplitude signal for determination the Modulation Factor at the ambient operating temperature

$$Modulation\ Factor = \frac{A - B}{A + B} = \frac{49.0 - 1.08}{49.0 + 1.08} = 95.68\%$$

Peak Equivalent Isotropic Radiated Power

On Ground Plane Radiated Power Test

Table 20.1 - Elevation Maximum search of Peak Equivalent Isotropic Radiated Power

Elevation, degrees	Antenna gain,dBi	Receive system attenuator and cable loss, dB	Free space propagation loss, dB	PEIRP,mW
5	1.10	1.10	34.173	12.3
10	1.10	1.10	34.272	13.9
15	1.10	1.10	34.441	14.3
20	1.10	1.10	34.680	14.4

Table 20.2 - Peak Equivalent Isotropic Radiated Power

Elevation, degrees	Azimuth, degrees	Antenna gain,dBi	Receive system attenuator and cable loss, dB	Free space propagation loss, dB	PEIRP, mW	PEIRP,d Bm
20.00	0	1.10	1.10	34.67	26.9	14.3
20.00	30	1.10	1.10	34.67	30.2	14.8
20.00	60	1.10	1.10	34.67	34.7	15.4
20.00	90	1.10	1.10	34.67	35.5	15.5
20.00	120	1.10	1.10	34.67	30.9	14.9
20.00	150	1.10	1.10	34.67	33.9	15.3
20.00	180	1.10	1.10	34.67	27.5	14.4
20.00	210	1.10	1.10	34.67	30.2	14.8
20.00	240	1.10	1.10	34.67	35.5	15.5
20.00	270	1.10	1.10	34.67	30.9	14.9
20.00	300	1.10	1.10	34.67	29.5	14.7
20.00	330	1.10	1.10	34.67	33.1	15.2

Results:

The median of twelve values was 31.5 mW (14.9 dBm).

Of the highest 11 values, the maximum was 35.5 mW and the minimum was 26.9 mW.

The ratio of maximum to minimum values is 1.3:1 (1.1 dB).

TEST EQUIPMENT

No	Name of test equipment	Type, model	ser. No	Calibration Due date
1.	Climatic chamber	GTH 408-70-CP-AR-LN2	MAA1212-004	12.2016
2.	Temperature meter	Gradient -2002	078	01.2017
3.	Beacon tester	BT-611	1005	11.2016
4.	Spectrum analyzer	FSH8	105763	10.2016
5.	Oscilloscope	TDS-3052	B011258	02.2017
6.	Coaxial detector	Agilent 8471E	100104	n/a
7.	Antenna	HK116	100345	08.2016
8.	Antenna mast	ATR 2	101208	n/a
9.	OATS No.33			07.2017
10.	RFAM	TernovnikMO	No.1	n/a
11.	Ground plane	Ug	102282	n/a

ANNEX 21.
COMPASS SAFE DISTANCE

Equipment Under Test (EUT): 1) MT603G
2) MT603FG

SW version: OS0021 ver 1.00 (8/12/2014)

Test Date: 25.04.16-26.04.16

Test Conditions:

- Ambient temperature: 16.8-20°C
- Relative humidity: 56-63%
- Atmospheric pressure: 743-745mm/Hg

TEST PROGRAM

Item	Test name	Requirements	Methods
1.	Compass safe distance	A.2.6 IEC 61097-2; 4.5.3 IEC 60945	5.20 IEC 61097-2; 11.2 IEC 60945

TEST DESCRIPTION

The EUT was tested in the position and attitude relative to the compass at which the error produced at the compass was a maximum, provided the item was fitted in this way.

The compass-safe distance of the EUT is defined as the distance between the nearest point of the unit and the centre of the compass or magnetometer at which it will not produce a deviation in the standard compass of more than $5.4^\circ/H$ where H is the horizontal component of the magnetic flux density in μT (microtesla) at the place of testing. For the steering compass, the standby steering compass and the emergency compass, the permitted deviation is $18^\circ/H$, H being defined as above.

The EUT was tested:

- a) in the magnetic condition in which it is received with the EUT unpowered;
- b) after normalizing with the EUT unpowered;
- c) in the powered condition, if the unit is capable of being energized electrically.

Normalizing means a procedure to maximize the homogeneity of the magnetic flux in the EUT by placing it in Helmholtz coils or by other adequate means.

In each of the above tests, the unit was rotated to determine the direction in which it produces the maximum deviation.

TEST RESULT FOR MT603G

Horizontal maximum flux density, μT	B=	20.9 μT
Standard compass deviation limit (degrees)	$5.4^\circ/B$	0.26°
Emergency compass deviation limit (degrees)	$18^\circ/B$	0.86°

The EUT was tested in the magnetic condition in which it is received. The EUT was unpowered. The direction in which the EUT produces the maximum deviation - horizontal antenna to the compass.

Then the EUT was tested after normalizing. The EUT was unpowered

The direction in which the EUT produces the maximum deviation - horizontal antenna to the compass.

Then the EUT was tested in the powered condition without manual bracket.

The direction in which the EUT produces the maximum deviation - horizontal antenna to the compass

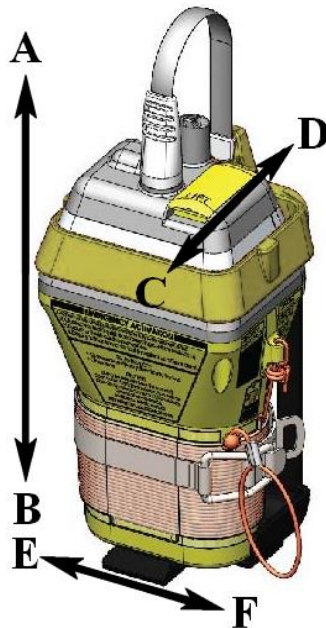

Figure 21.1 - The orientation of the MT603G to the long axis



Figure 21.2 - Test installation



Figure 21.3 - The safety distance from EUT in stand-by mode to standard compass is 0.28 m (position F)

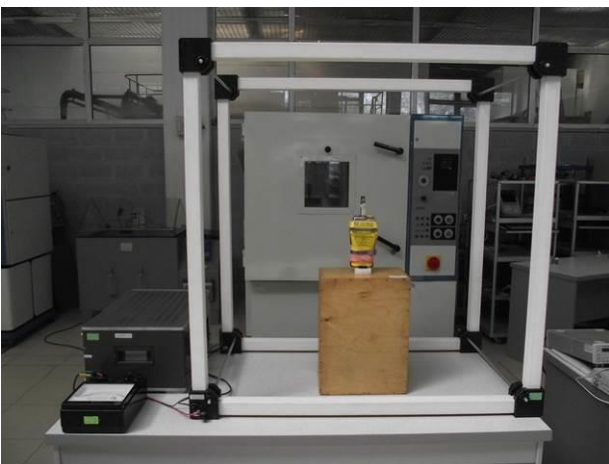

Figure 21.4 – Installation for normalizing



Figure 21.5 - The safety distance from EUT in operation mode to standard compass is 0.125 m (position D)

The orientation of the test equipment to the long axis	EUT unpowered		After normalizing with the EUT unpowered		Operation mode	
	The distance to the compass for deviation		The distance to the compass for deviation		The distance to the compass for deviation	
	0.26°	0.86°	0.26°	0.86°	0.26°	0.86°
Direction "A" – Horizontal antenna to the compass	<0.1m	<0.1m	0.1 m	<0.1m	<0.1 m	<0.1 m
Direction "B" – Horizontally to the bottom of the compass	0.13 m	<0.1m	0.15 m	0.1 m	<0.1m	<0.1 m
Direction "C" - Horizontally, the front of the EPIRB to the compass	0.215 m	0.13 m	0.23 m	<0.1 m	0.1 m	<0.1 m
Direction "D" - Horizontally mounting bracket to the compass	0.15 m	<0.1m	0.18 m	0.14 m	0.125m	<0.1 m
Direction "E" - Horizontally, the left side of the mounting brackets to the compass	0.24 m	0.14 m	0.25 m	0.13 m	<0.1 m	<0.1 m
Direction "F" - Horizontally, the right side of the mounting brackets to the compass	0.27 m	0.18m	0.26 m	0.15 m	<0.1 m	<0.1 m
Direction "C" - Vertically, the front of the EPIRB to the compass	0.21 m	0.21 m	0.23 m	0.13 m	0.12 m	<0.1m
Direction "D" – Vertical mounting bracket to the compass	0.13 m	<0.1m	0.15 m	0.13 m	0.125 m	<0.1m
Direction "E" - Vertically, the left side of the mounting brackets to the compass	0.17 m	0.13 m	0.18 m	0.12 m	<0.1 m	<0.1m
Direction "F" - Vertically, the right side of the mounting brackets to the compass	0.28 m	0.16 m	0.27 m	0.16 m	<0.1 m	<0.1m

Test results:

The safety distance from EUT in stand-by mode to compass is 0.3 m (in compliance with the required IEC 60945 item 11.2.3).

Results required IEC 60945 item 11.2.3.

The greatest distance obtained under all these conditions is the safe distance. Distances are rounded up to the nearest 50 mm or 100 mm.

The safe distance shall be marked on the EUT.

TEST RESULT FOR MT603FG

Horizontal maximum flux density, μT	$B=$	20.9 μT
Standard compass deviation limit (degrees)	$5.4^\circ/B$	0.26°
Emergency compass deviation limit (degrees)	$18^\circ/B$	0.86°

The EUT was tested in the magnetic condition in which it is received. The EUT was unpowered. The direction in which the EUT produces the maximum deviation is horizontal antenna to the compass. Then the EUT was tested after normalizing. The EUT was unpowered. The direction in which the EUT produces the maximum deviation is horizontal antenna to the compass.

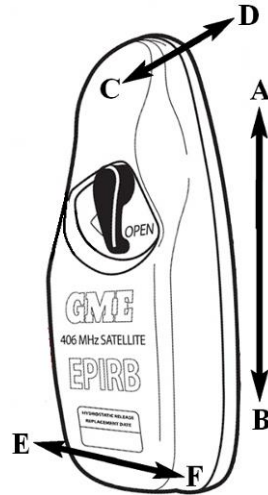

Figure 21.6 - The orientation of the EUT to the long axis



Figure 21.7 - The safety distance from EUT to standard compass is 0.74 m (position E).



Figure 21.8 - Installation for normalizing



Figure 21.9 - The safety distance from EUT in operation mode to standard compass is 0.23 m (position B)

The orientation of the test equipment to the long axis	EUT unpowered		After normalizing with the EUT unpowered		Operation mode	
	The distance to the compass for deviation		The distance to the compass for deviation		The distance to the compass for deviation	
	0.26°	0.86°	0.26°	0.86°	0.26°	0.86°
Direction "A" - Horizontal antenna to the compass	0.14m	<0.1m	0.16 m	<0.1 m	<0.1 m	<0.1 m
Direction "B" – Horizontally to the bottom of the compass	0.21 m	<0.1m	0.27 m	<0.1 m	<0.1 m	<0.1 m
Direction "C" - Horizontally, the front of the EPIRB to the compass	0.352 m	0.185 m	0.325 m	0.195m	<0.1 m	<0.1 m
Direction "D" - Horizontally mounting bracket to the compass	0.22 m	0.14m	0.265 m	0.13 m	0.12m	<0.1 m
Direction "E" - Horizontally, the left side of the mounting brackets to the compass	0.24 m	0.16 m	0.23 m	0.12 m	<0.1 m	<0.1 m
Direction "F" - Horizontally, the right side of the mounting brackets to the compass	0.372 m	0.17 m	0.356 m	0.18 m	<0.1 m	<0.1 m
Direction "C" - Vertically, the front of the EPIRB to the compass	0.36 m	0.22 m	0.32 m	0.25 m	0.11 m	<0.1 m
Direction "D" – Vertical mounting bracket to the compass	0.26 m	0.16m	0.275 m	0.17 m	0.12 m	<0.1 m
Direction "E" - Vertically, the left side of the mounting brackets to the compass	0.15 m	<0.1m	0.18 m	<0.1 m	<0.1 m	<0.1 m
Direction "F" - Vertically, the right side of the mounting brackets to the compass	0.295 m	0.15 m	0.365 m	0.175 m	<0.1 m	<0.1 m

Test results:

The safety distance from EUT to compass is 0.4 m (in compliance with the required IEC 60945 item 11.2.3).

Results required IEC 60945 item 11.2.3.

The greatest distance obtained under all these conditions is the safe distance. Distances are rounded up to the nearest 50 mm or 100 mm.

The safe distance shall be marked on the EUT.

TEST EQUIPMENT USED

No	Name of test equipment	Type, model	ser. No	Calibration Due date
1.	Ruler	Lineyka-1000	64	03.2018
2.	Hygrometer digital	HP 22-A	60974546	09.2016
3.	Uncompensated magnetic compass (marine compass, compass rose diameter 127 mm, scale interval 1°.	КИ-13	25	05.2016
4.	Tool for workplace equipment for testing magnetic effect	-	101555	06.2016
5.	Power supply	SEA PS 3020	100185	02.2018
6.	Multimeter	M2051	1908	12.2016
7.	Helmholtz coils	HHS 5210	1	06.2016
8.	Microscope	MPB-3	9008069	12.2017
9.	Magnetometer	HB0599A	12010701	02.2017

ANNEX 22.
CORROSION TEST

Extractions from
TEST REPORT No. 16/224 Issue 3
Emergency Position Indicating Radio Beacon (EPIRB)
for compliance with RTCM Standard 11000.2
Model MT603G, MT603FG
Manufacturer Standard Communications Pty
Ltd, Australia

----- Extraction from Test Report No.16/224 -----

**ANNEX 6.
SALT FOG TEST (A7.0)****Equipment Under Test (EUT):** MT603G
MT603FG**SW version:** OS0021 ver 1.00 (8/12/2014)**Test Date:** from 15.01.2016 until 19.01.2016**Test Conditions:**

- Ambient temperature: 15.8-17.9 °C
- Relative humidity: 47-51 %
- Atmospheric pressure: 750-759 mm/Hg

TEST DESCRIPTION

The salt fog test should be conducted on a Category 2 satellite EPIRBs with its mounting device. The EUT should be turned OFF during the test.

Before exposing the EUT to salt fog, it should be conditioned for duration of at least 2 hours at a temperature of 35° C ± 2° C. After this conditioning and with the ambient temperature maintained at 35° C, salt fog should be added and maintained at the saturation point for 48 hours.

The salt fog should be prepared from a 5% ± 1% salt (sodium chloride) solution.

After exposure to salt fog, the EUT should be permitted to dry at room temperature (20° C ± 5° C) for 24 hours before being exposed to another period of 12 hours of salt fog exposure at 35° C.

Upon completion of this exposure and after a 12 hour drying period at room temperature, the exterior of the unit should be inspected for corrosion, peeling paint, and other signs of deterioration and the aliveness test conducted.

TEST RESULT

- EPIRB is OFF during the test.
- Preparation of salt solution: Resistance distilled, demineralized, deionized use water not introduces contaminants is 555 kOhms/cm. Salt solution concentration is 5.2%. Salt solution containing (on dry basis) 0.02% sodium iodide and 0.07 % total impurities. Salt solution pH is 6.9. Preheat temperature compressed air (before atomizing) is 46.3 °C. Air pressure is 83.5 kPa. Reference MIL-STD-810D (19 July 1983) method 509.2 item II-2.2 on the preparation of 5% salt solution.
- Preparation of salt fog: from a 5% salt (sodium chloride) solution. Salt fog fallout such that each receptacle collects is 2.4 ml of solution per hour for each 80 cm³ of horizontal collecting area (10 cm diameter) in an average test at 16 hours. Salt fogpH is 7.0. Reference MIL-STD-810D (19 July 1983) method 509.2 item II-1 on the preparation of the apparatus for generating salt fog.

- Step 1 Condition: temperature +35 °C in the chamber with EUT duration 2 hours; no salt fog;
 - Step 2 Condition: temperature +35 °C in the salt fog chamber with EUT duration 48 hours; exposed to salt fog;
 - Step 3 Condition: temperature is +20 °C in the chamber with EUT duration 24 hours; no salt fog;
 - Step 4 Condition: temperature is +35 °C in the salt fog chamber with EUT duration 12 hours; exposed to salt fog;
 - Step 5 Condition: temperature is +20 °C in the chamber with EUT; no salt fog; duration 12 hours;
 - Step 6 Corrosion, peeling paint, and other signs of deterioration are inspected;
 - Step 7 Salt deposits and water stains is wash off with clean warm water not exceeding a temperature +38 °C;
 - Step 8 Aliveness test of EUT upon completion of the salt fog test.
-



Figure 22.1 – Views of the EUT in salt fog chamber



Figure 22.2 – View exterior inspection of the MT603G upon completion of the salt fog test



Figure 22.3 – View exterior inspection of the MT603G upon completion of the salt fog test

Table 22.1 — Detailed measurement results of EUT model MT603G after of the salt fog test

Test duration 0 h 1 m	Bursts received 3	BCH error 0	Self-Test 0		
406 MHz Transmitter Parameters	Limits		Measured		
	min	max	min	current	max
Frequency, kHz	406039.000	406041.000	406039.858	406039.858	406039.858
Power, Wt	3.16	7.94	4.32	4.32	4.32
121.5 MHz Transmitter Parameters					
Carrier Frequency, Hz	1216487302				
Power, dBm	12.91				
Message					
Digital message	FFFE2F8C9E0000007FDFFA79ED3783E0F66C				

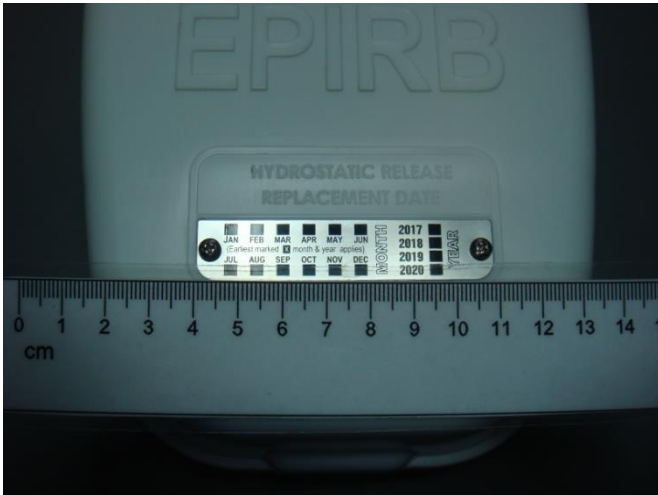

Figure 22.4 – View exterior inspection of the MT603FG upon completion of the salt fog test



Figure 22.5 – View exterior inspection of the MT603FG upon completion of the salt fog test

Table 22.2 — Detailed measurement results of EUT model MT603FG after of the salt fog test

Test duration 0 h 1 m	Bursts received 3	BCH error 0	Self-Test 0		
406 MHz Transmitter Parameters	Limits		Measured		
	min	max	min	current	max
Frequency, kHz	406039.000	406041.000	406040.131	406040.127	406040.127
Power, Wt	3.16	7.94	4.30	4.30	4.30
121.5 MHz Transmitter Parameters					
Carrier Frequency, Hz	1216493651				
Power, dBm	12.91				
Message					
Digital message	FFFE2F8C9E0000007FDFFA79ED3783E0F66C				

TEST EQUIPMENT

No	Name of test equipment	Type, model	ser. No	Calibration Due date
11.	Salt Fog Chamber	DS090-X	20807004	05.2016
12.	Temperature meter	gradient 2002	078	01.2017
13.	Hygrometer digital	HP 22-A	60974546	09.2016
14.	Beacon tester	BT100AVS	2315	07.2016
15.	Beacon tester	BT-611	1005	11.2016
16.	Spectrum analyzer	FSH8	105763	10.2016
17.	Tuned dipole antenna	FCC-4	587A	09.2016

----- End of Extraction from Test Report No.16/224 -----

ANNEX 23.
ERGONOMICS CHECK

Equipment Under Test (EUT): MT603FG

SW version: OS0021 ver 1.00 (8/12/2014)

Test Date: 18.04.16

Test Conditions:

- Ambient temperature: 21.1 °C
- Relative humidity: 53 %
- Atmospheric pressure: 755 mm/Hg

TEST PROGRAM

Item	Test name	Requirements	Methods
1.	Ergonomics check	A.2.1, 3.3.8 IEC 61097-2	5.3.8 IEC 61097-2
2.	Check the possibility of manual release and capability be carried by one person	3.2 a) IEC 61097-2	5.2 IEC 61097-2
3.	Manual release	A.2.1, 3.5.4 IEC 61097-2	5.5.4 IEC 61097-2

DESCRIPTION OF TEST

The satellite EPIRB shall have all controls of sufficient size for simple and satisfactory operation and also be capable of being operated by a person wearing an immersion suit as defined in the IMO Lifesaving Appliance Code (Resolution MSC.48(66), section 2.3). This shall include removing the EPIRB from its bracket, manual activation and deactivation of the control function and deployment of the lanyard.

The satellite EPIRB shall be ready to be manually released and capable to be carried by one person into a survival craft.

It shall be possible to release the satellite EPIRB manually from the float-free mechanism, without tools.

TEST RESULT

Passed

TEST DETAILS

Parameter	Result	Conclusion
Controls size	all controls have sufficient size for action (see photos)	Pass
Removing the EPIRB from its bracket	inspected	Pass
Manual activation	inspected	Pass
Manual deactivation	inspected	Pass
Deployment of the lanyard	inspected	Pass
Readiness to be manually released and capable to be carried by one person into a survival craft	inspected	Pass
Manual release	inspected	Pass

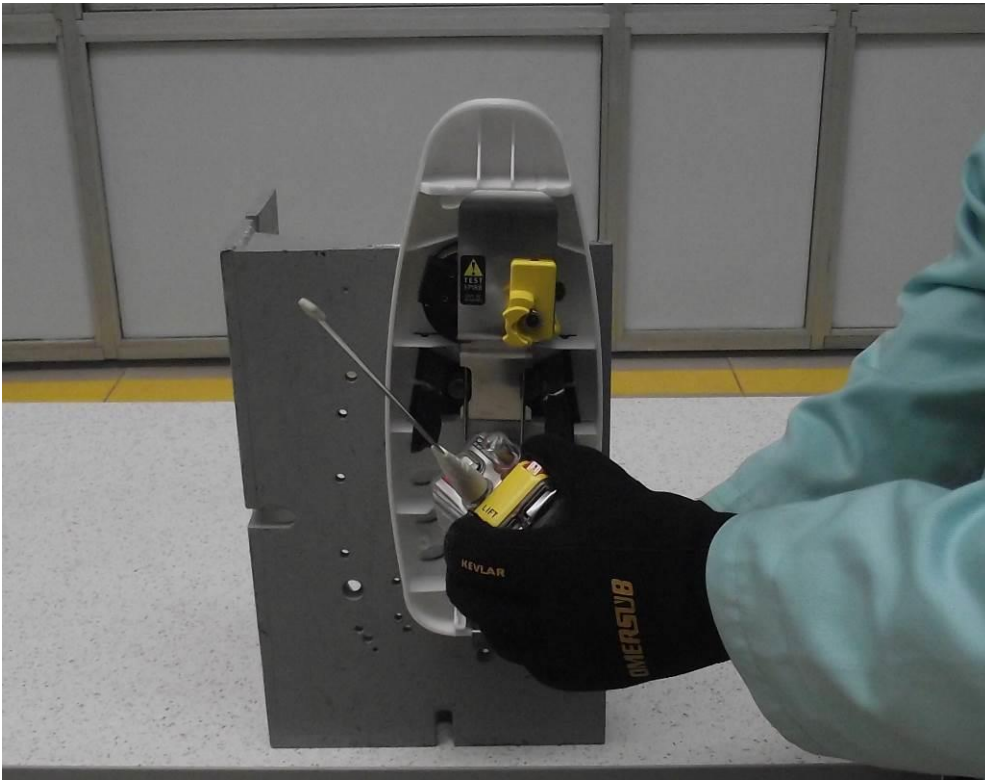

Figure 23.1 — EUT has all controls of sufficient size for simple and satisfactory operation and also be capable of being operated by a person wearing an immersion suit



Figure 23.2 — Removing the MT603FG from Manual Release Housing (MRH)

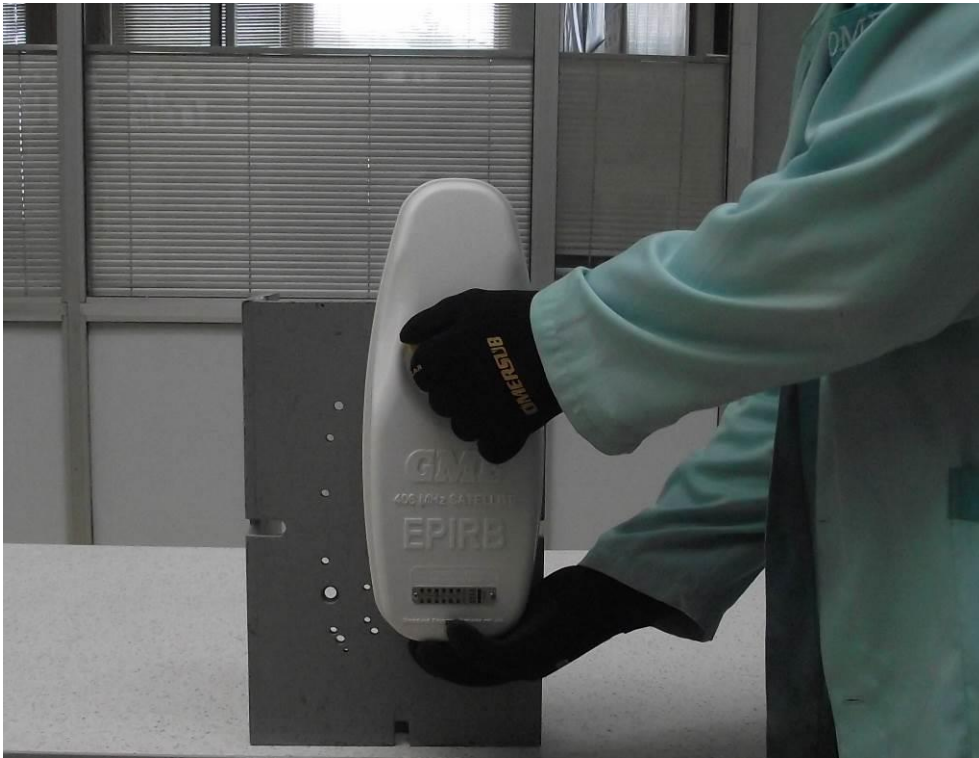

Figure 23.3 — Removing the MT603FG from Manual Release Housing (MRH)

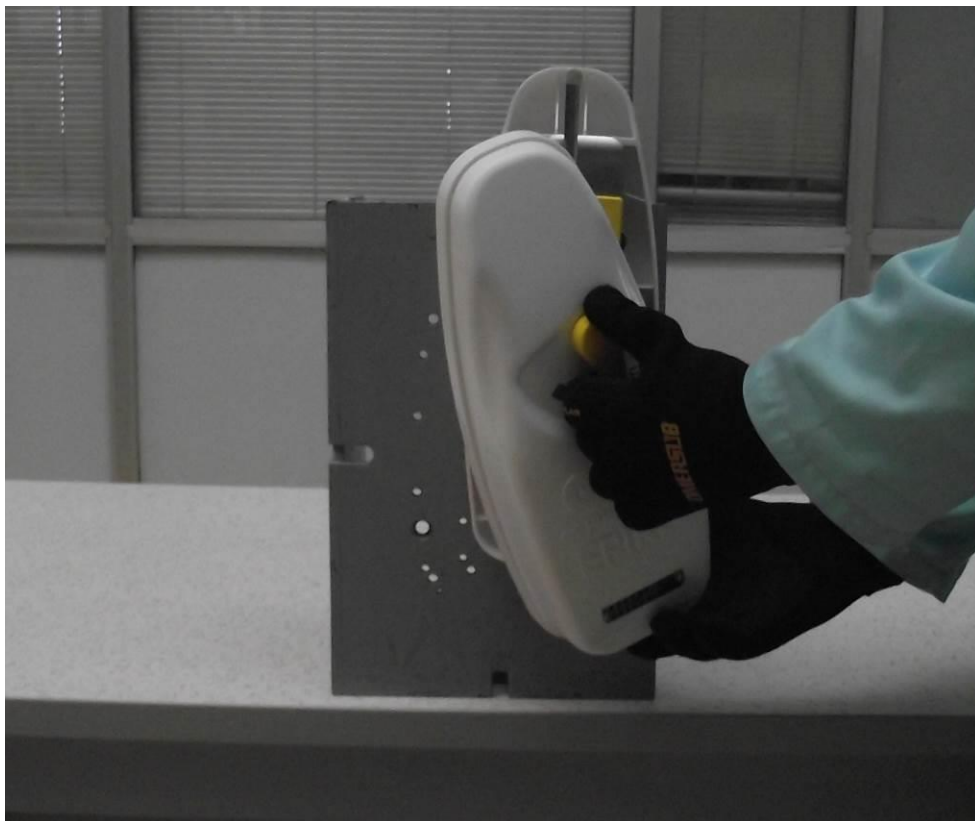

Figure 23.4 — Removing the MT603FG from Manual Release Housing (MRH)

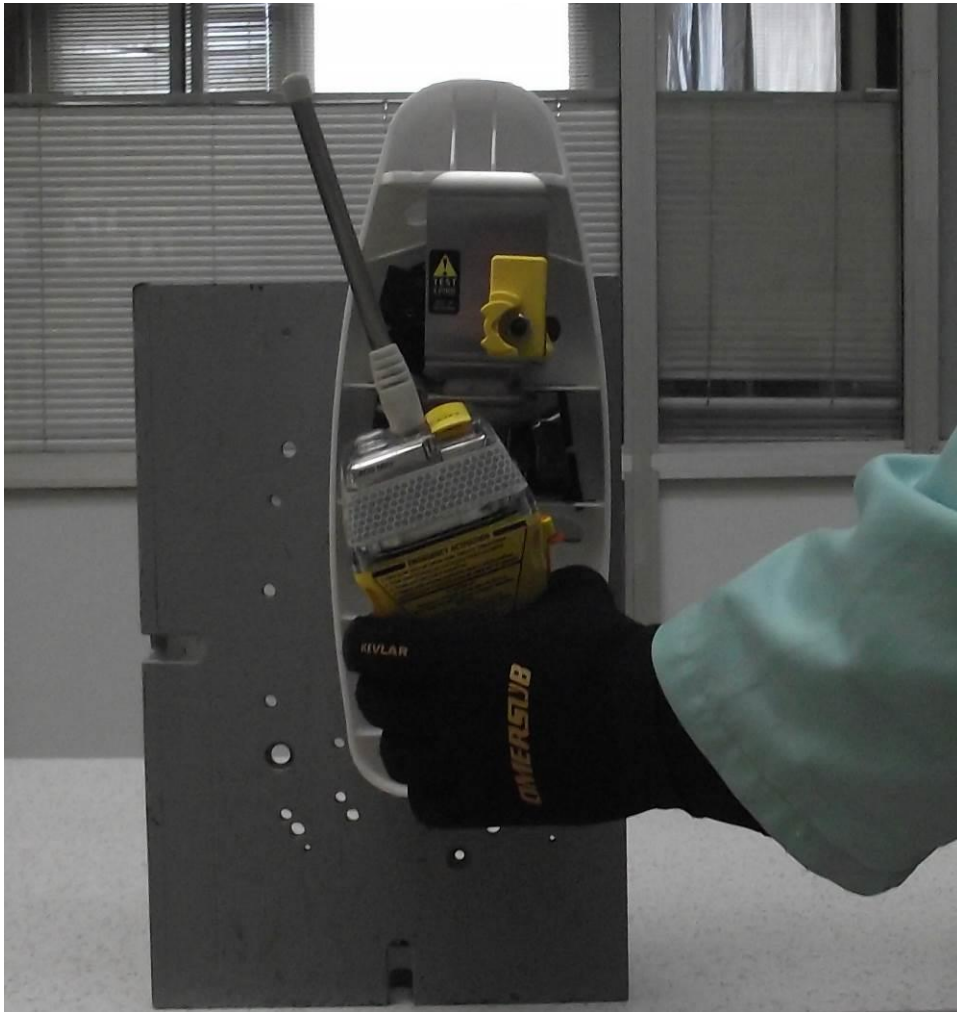

Figure 23.5 — Removing the MT603FG from Manual Release Housing (MRH)

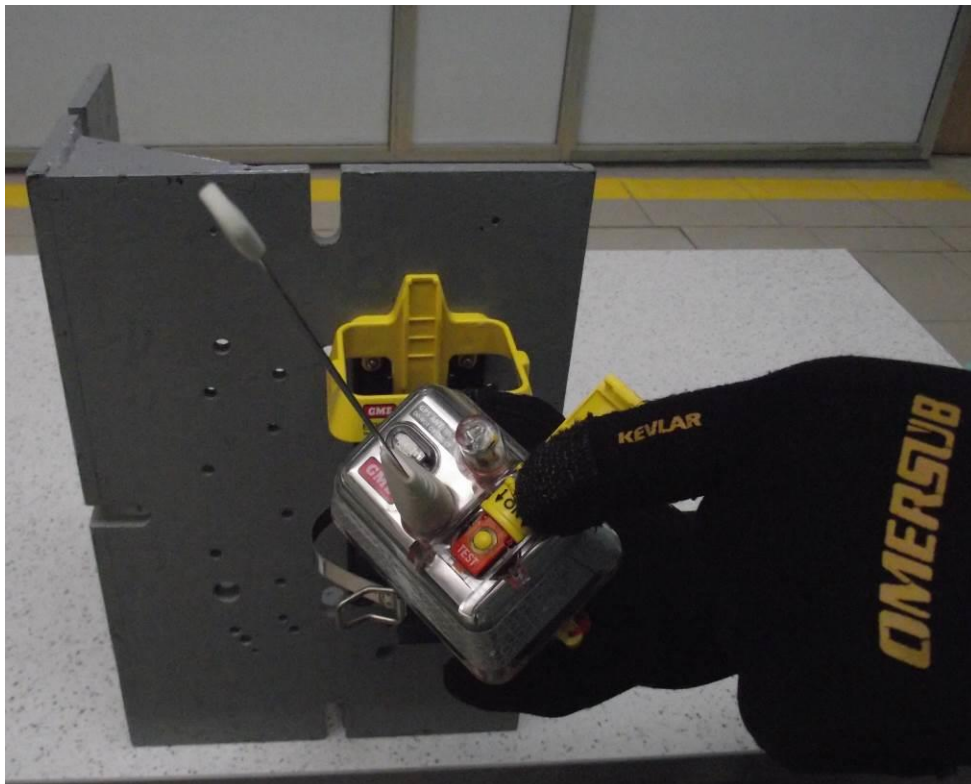

Figure 23.6 — Manual Test mode activation

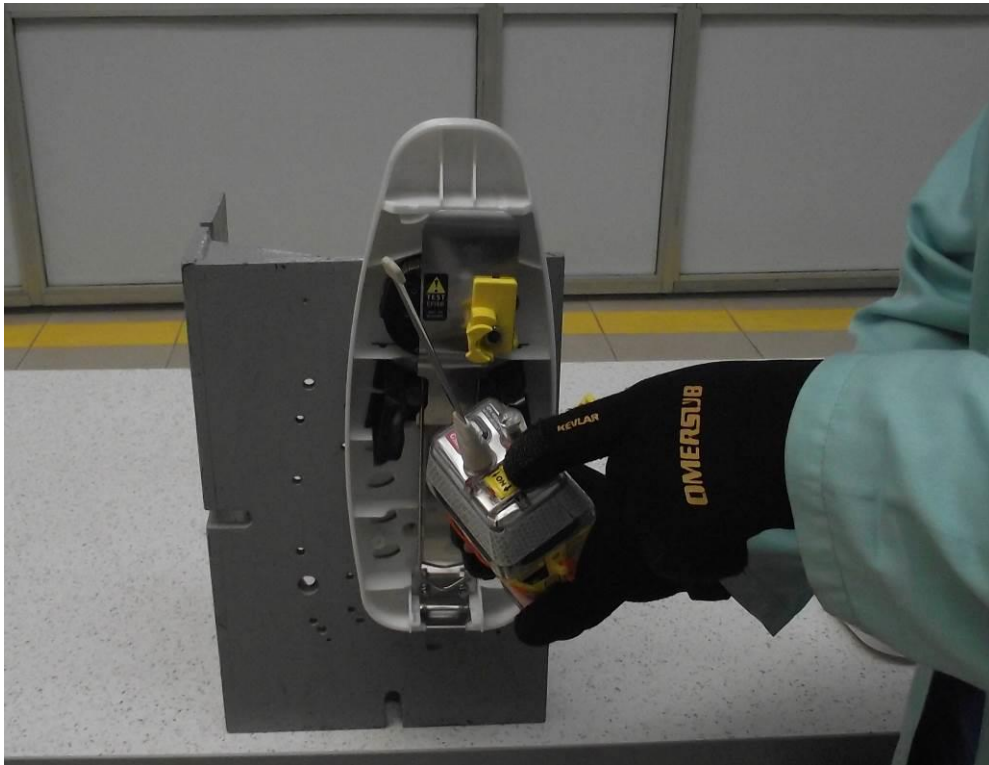

Figure 23.7 — Manual activation

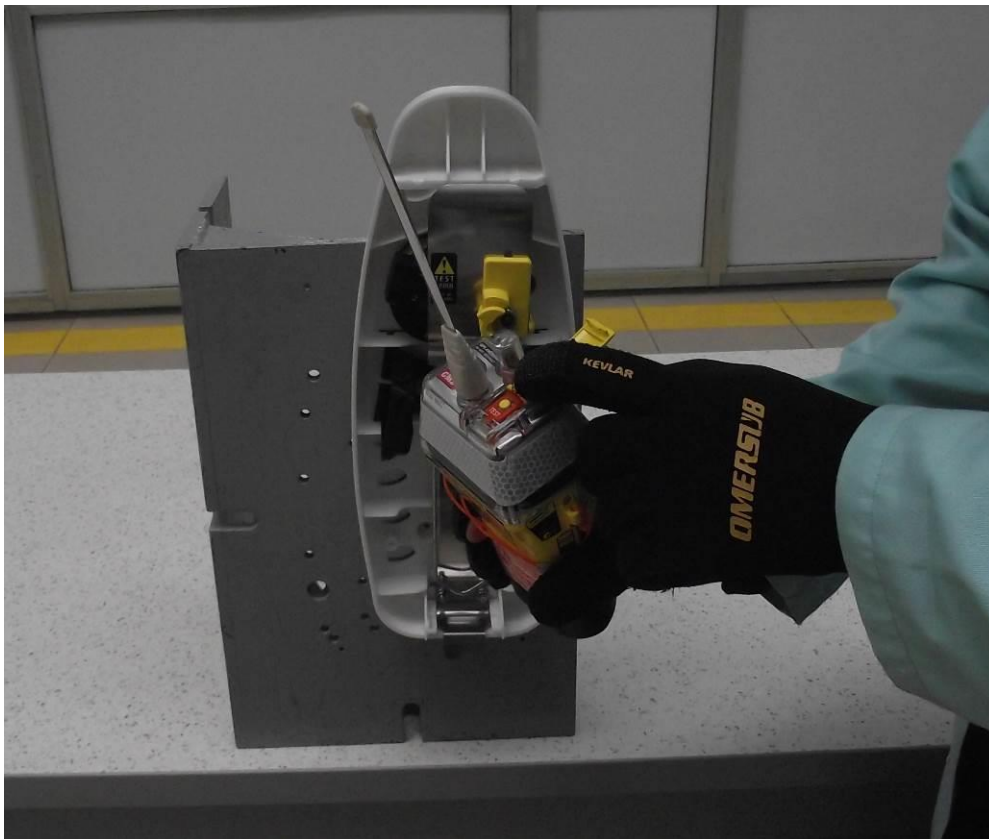

Figure 23.8 — Manual activation



Figure 23.9 — Manual deactivation

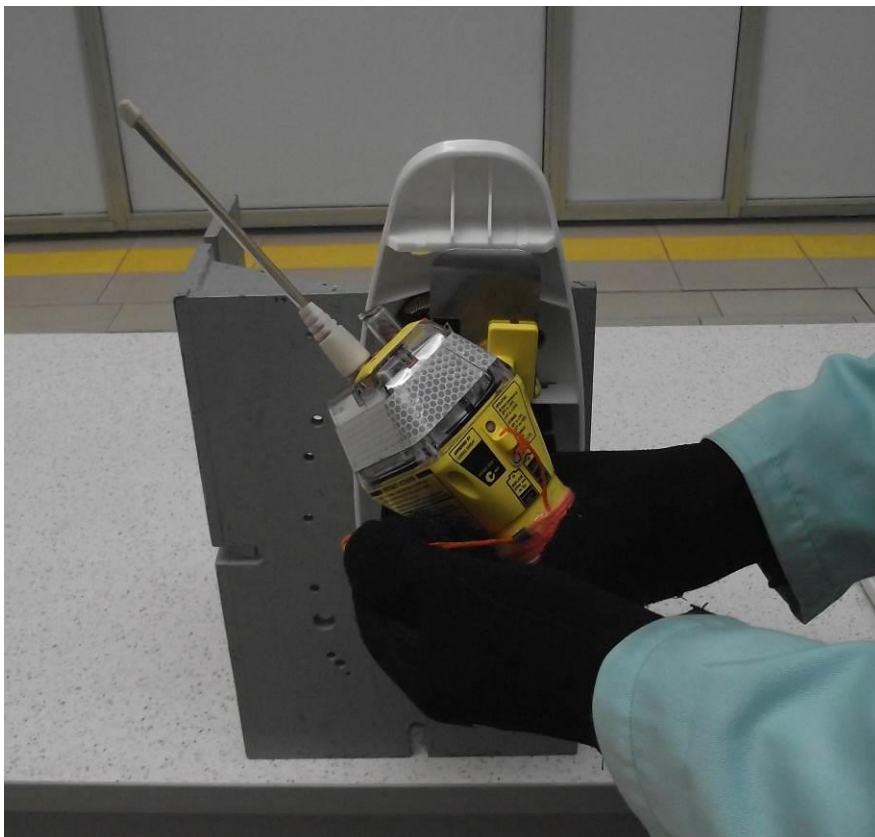

Figure 23.10 — Deployment of the lanyard



Figure 23.11 — Deployment of the lanyard

TEST EQUIPMENT USED

No	Name of test equipment	Type, model	ser. No	Calibration Due date
1.	Gloves from an IMO SOLAS 17 compliant immersion suit.	-		N/A

ANNEX 24.
DISTRESS FUNCTION CHECK

Equipment Under Test (EUT): MT603G

SW version: OS0021 ver 1.00 (8/12/2014)

Test Date: 18.04.2016

Test Conditions:

- Ambient temperature: 21.1°C
- Atmospheric pressure: 755 mm/Hg
- Relative air humidity: 53 %

TEST PROGRAM

Item	Test name	Requirements	Methods
1.	Distress Function Check	A.2.1, 3.4 IEC 61097-2	5.4 IEC 61097-2

TEST DESCRIPTION

When the satellite EPIRB is manually operated a distress alert shall be initiated only by means of a dedicated distress alert activator.

The dedicated activator shall:

- a) be clearly identified;
- b) be protected against inadvertent operation

Manual distress alert initiation shall require two independent actions neither of which on its own shall activate the satellite EPIRB.

The satellite EPIRB shall not be automatically activated after being manually removed from the release mechanism.

TEST RESULT

Passed

TEST DETAILS

Parameter	Result
Clearly identified activator of distress signal check	Inspected
Initiation with two independent actions	Checked
Protected against inadvertent operation check	Checked
Not automatically activated after being manually removed from the release mechanism check	Checked



Figure 24.1 - Activator of distress signal



Figure 24.2 - Manual distress alert initiation step 1

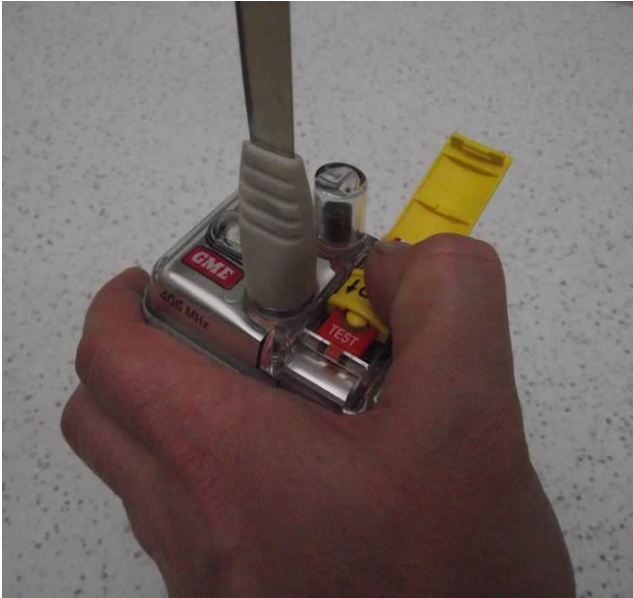

Figure 24.3 - Manual distress alert initiation step 2



Figure 24.4 - Manual distress alert initiation step 3



Figure 24.5 - Removed EUT from the Manual Release Housing (MRH) and Manual bracket. EPIRB was not automatically activated

**ANNEX 25.
LABELING CHECK**

Equipment Under Test (EUT): MT603FG

SW version: OS0021 ver 1.00 (8/12/2014)

Test Date: 05.05.2016

Test Conditions:

- Ambient temperature: 20.7 °C
- Relative humidity: 61 %
- Atmospheric pressure: 753 mm/Hg

TEST PROGRAM

Item	Test name	Requirements	Methods
1.1	Equipment labelling	3.12.1 IEC 61097-2	5.12.1 IEC 61097-2
1.2	Float-free arrangement labelling	3.12.2 IEC 61097-2	5.12.2 IEC 61097-2
1.3	Battery expiry date	A.2.1, 4.6.3 IEC 61097-2	5.15.2 IEC 61097-2
1.4	Reverse polarity protection	A.2.1, 4.6.4 IEC 61097-2	5.15.3 IEC 61097-2

DESCRIPTION OF TEST

The label or labels shall be placed on the satellite EPIRB itself and on its container.

The following shall be clearly indicated on the exterior of the equipment:

- a) brief operating instructions at least in English, to enable manual activation, deactivation and self-test ;
- b) a warning to the effect that the satellite EPIRB shall not be operated except in an emergency;
- c) type designation and class as specified by the manufacturer, type of battery and expiry date for the primary battery used. Means shall be provided to change this date when the battery is replaced;
- d) the name of the ship and beacon identification data:
 - 1) the identity code programmed into the transmitter of the satellite EPIRB (i.e. hexadecimal representation of bits 26 to 85 of the digital message, as described in C/S T.001), together with the call sign or MMSI of the ship as required by the Administration and the MID;
 - 2) country (i.e. name of country as programmed in the MID);
 - 3) a space for registration information (for instance Decals) as required by administrations;
- e) if applicable, for those satellite EPIRBs with an integral GNSS receiver or that can be interfaced with an external GNSS receiver, a statement that the device either contains a GNSS receiver or may be interfaced to one and, if necessary, brief operating instructions relevant to this feature;
- f) a warning to limit testing to the first five minutes of the hour, as the satellite EPIRB emits a 121,5 MHz signal during self-test.

The Manual release arrangement shall carry a label or labels indicating clearly at least in English:

- the operating instructions for manual release;

TEST RESULT

Passed

TEST DETAILS

Parameter	Result
EPIRB Labelling	Inspected
Battery expiry date	Inspected
Reverse polarity protection	Inspected
Manual release arrangement labelling	Inspected



Figure 25.1 — Photo of marking of top view



Figure 25.2 — Labelling of warning on the cover that the EPIRB is activated in emergency only

The label was placed on the satellite EPIRB itself. It indicates type of battery and expiry date for the primary battery used.

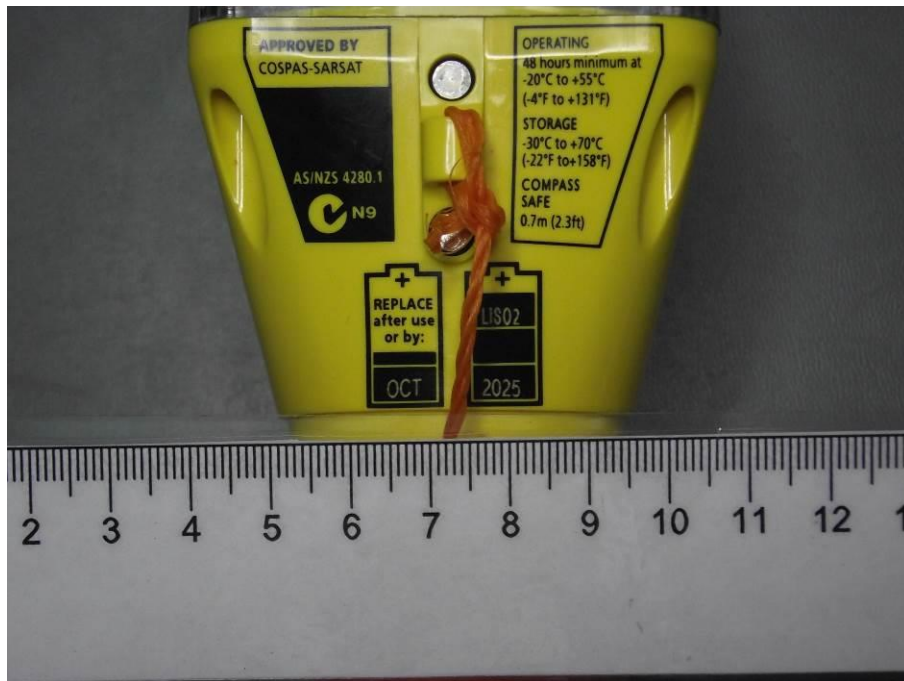

Figure 25.3 — Labeling class beacon, and expiry date when battery should be replaced

Reverse polarity protection is achieved by using specially shaped connector, which makes it impossible to inclusion with the change polarity, as well as rigid fixation of the wires connected to the battery.

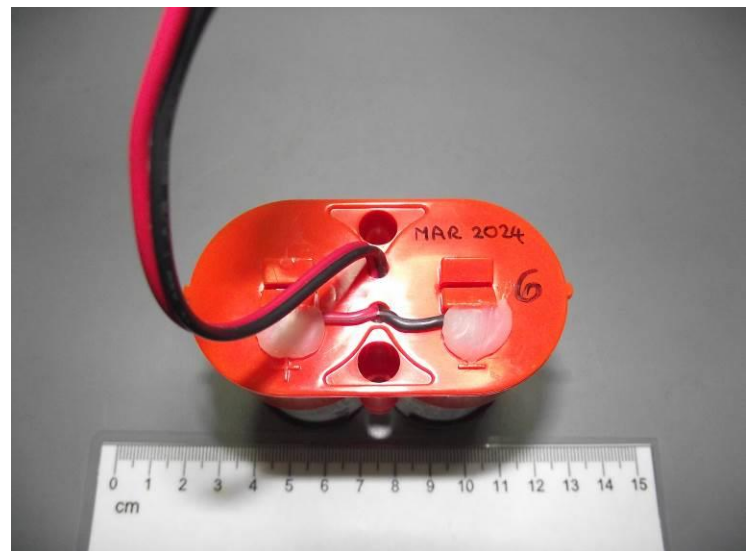
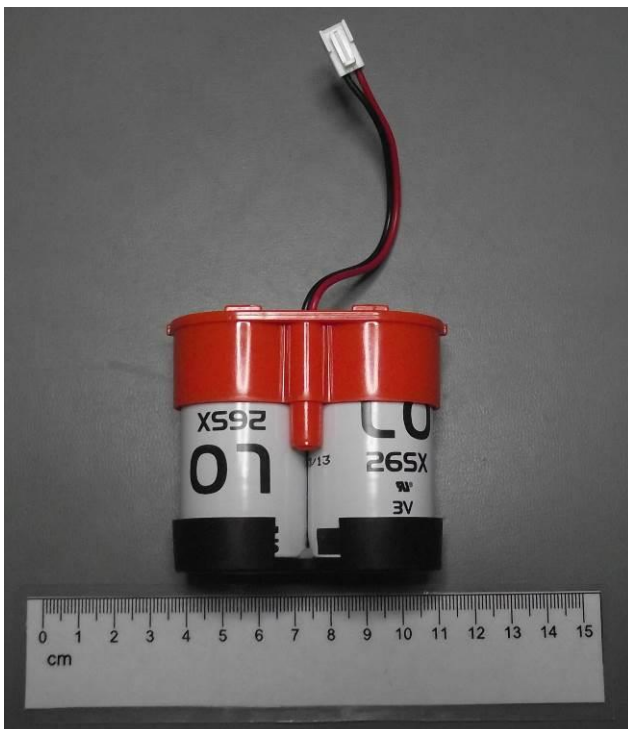

Figure 25.4 — View to Battery Connector to reverse polarity protection



Figure 25.5— Labelling of vessel (Vessel Name) and identifier number (UIN)



Figure 25.6— Labelling of brief manual activation instruction

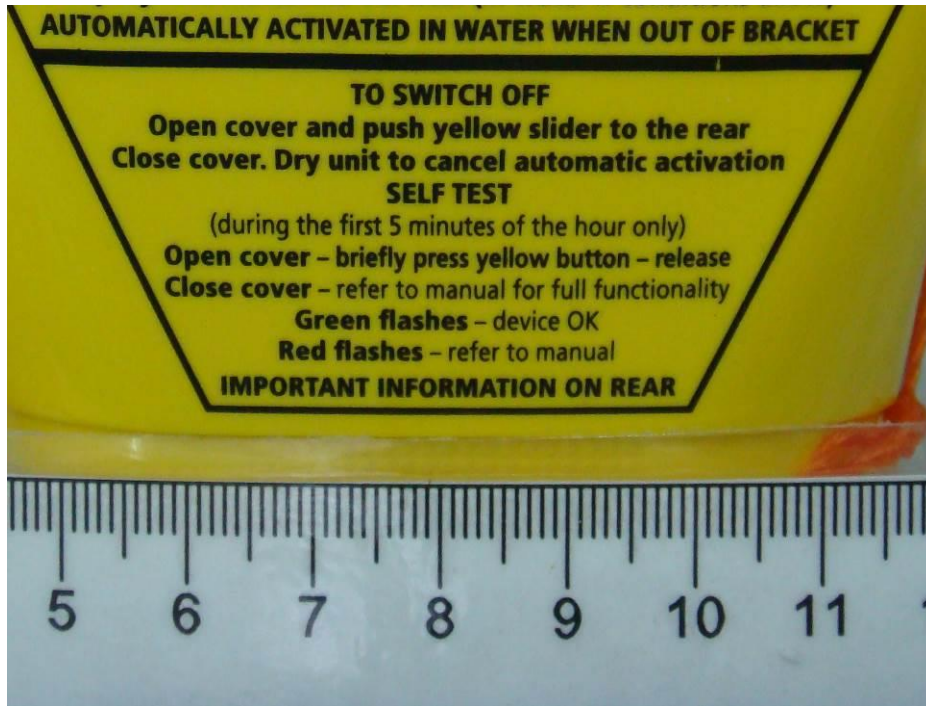

Figure 25.7— Labelling of information to automatic activation, deactivation and warning to limit tasting to the first five minutes of the hour.

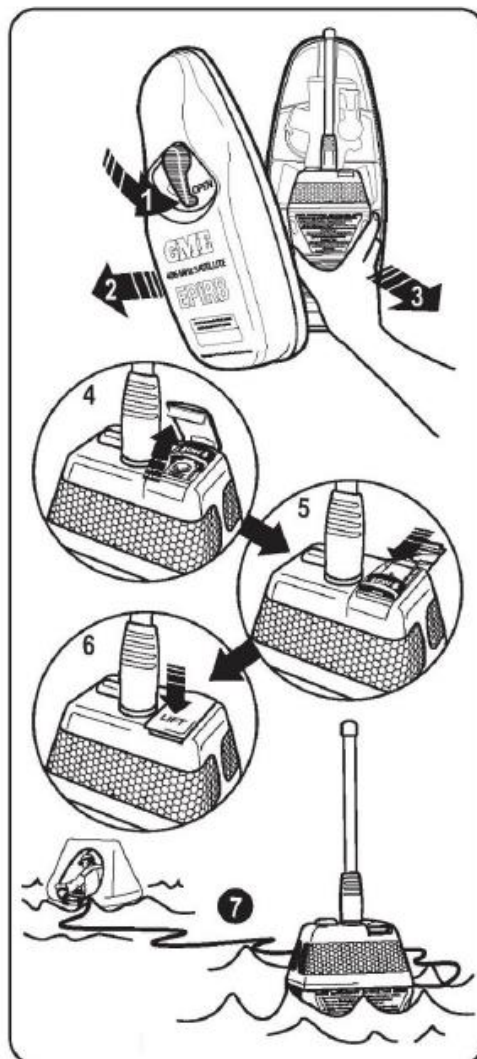

Figure 25.9— Photo of MRH manual activating instruction.

ANNEX 26.
EQUIPMENT MANUAL CHECK

Equipment Under Test (EUT): MT603FG

SW version: OS0021 ver 1.00 (8/12/2014)

Test Date: 05.05.2016

TEST PROGRAM

Item	Test name	Requirements	Methods
1.	Equipment manual check	3.11 IEC 61097-2	5.11IEC 61097-2

DESCRIPTION OF TEST:

Equipment manual was checked.

The information supplied with the satellite EPIRB shall include pictorial operating instructions on a waterproof placard, suitable for mounting on a bulkhead. Numerals may be used to indicate the order of the illustrated operations, but words should not be used as part of the instructions.

The equipment manual also shall include:

- an overview of the COSPAS-SARSAT system;
 - complete instructions for the operation and the self testing of the satellite EPIRB;
 - cautions and recommendations to prevent false alerts;
 - instructions for licensing and registration, registration renewal and a discussion on the importance of accurate registration;
 - battery information including replacement instructions, battery type, and safety information regarding battery use and disposal;
 - an instruction to replace the battery after the satellite EPIRB is operated for any purpose other than a test;
 - the minimum operating life-time and operating and stowage temperatures;
 - the purpose of the lanyard and a precaution against using it to secure the satellite EPIRB to the ship;
 - a recommendation against attempting to operate the satellite EPIRB inside a life raft or under any similar cover or canopy;
 - the servicing and/or replacement of any hydrostatic release unit and any associated components subject to ageing, such as release rods;
 - manufacturer recommendations, if any, on periodic functional testing, possibly in connection with battery replacement;
 - a note to keep the original satellite EPIRB packaging, since it may be needed if the EPIRB has to be shipped for servicing. UN requirements for shipping some batteries as hazardous goods require certain packaging standards and labeling;
 - instructions for the safe transportation or shipping of the satellite EPIRB or the location where such information can be obtained by the user;
 - warranty information;
 - a warning to the effect that the Satellite EPIRB shall not be operated except in an emergency;
 - a warning against installation near strong magnetic fields, if that might activate the satellite EPIRB;
 - a recommendation to mounting the satellite EPIRB as high as possible, especially on small vessels. This will help ensure operation of the hydrostatic float-free release unit, in the event the vessel capsizes without sinking;
 - a recommendation to limit self-testing to the minimum necessary to ensure confidence in the operation of the satellite EPIRB;
 - a warning to limit testing to the first five minutes of the hour, as the satellite EPIRB emits a 121.5 MHz signal during self-test;
-

- if appropriate a list of approved external GNSS Receivers for those satellite EPIRBs accepting external navigation inputs together with instructions for connecting and setting up the external devices;
- if appropriate for those satellite EPIRBs with an integral GNSS receiver or that can be interfaced with an external GNSS receiver, information to guide the operator towards maximizing self-locating performance including a warning not to obstruct the GNSS antenna's view of the sky.

The equipment manual shall include information explaining the necessity to report satellite EPIRB false alarms by the most expedient means to the nearest search and rescue authorities. The information that should be reported includes the satellite EPIRB 15-Hex ID; date, time, duration and cause of activation; and location at time of deactivation.

TEST RESULT

Passed

TEST DETAILS

Required information for Equipment Manual	Reference on Equipment Manual page	Result
An overview of the COSPAS-SARSAT system	Page 17	Pass
Complete instructions for the operation and the self testing of the satellite EPIRB	Page 9-10,12-16	Pass
Cautions and recommendations to prevent false alerts	Page 7, 11	Pass
Instructions for licensing and registration, registration renewal and a discussion on the importance of accurate registration	Page 6	Pass
Battery information including replacement instructions, battery type, and safety information regarding battery use and disposal	Page 11	Pass
An instruction to replace the battery after the satellite EPIRB is operated for any purpose other than a test	Page 11	Pass
The minimum operating life-time and operating and stowage temperatures	Page 18	Pass
The purpose of the lanyard and a precaution against using it to secure the satellite EPIRB to the ship	Page 10	Pass
Recommendation against attempting to operate the satellite EPIRB inside a life raft or under any similar cover or canopy	Page 10	Pass
The servicing and/or replacement of any hydrostatic release unit and any associated components subject to ageing, such as release rods	Page 11-12	Pass
Manufacturer recommendations, if any, on periodic functional testing, possibly in connection with battery replacement	Page 12	Pass
A note to keep the original satellite EPIRB packaging, since it may be needed if the EPIRB has to be shipped for servicing. UN requirements for shipping some batteries as hazardous goods require certain packaging standards and labelling	Page 16-17	Pass
Instructions for the safe transportation or shipping of the satellite EPIRB or the location where such information can be obtained by the user	Page 6, 16	Pass
Warranty information	Page 20	Pass
A warning to the effect that the Satellite EPIRB shall not be operated except in an emergency	Page 5	Pass
A warning against installation near strong magnetic fields, if that might activate the satellite EPIRB	Page 7	Pass
A recommendation to mounting the satellite EPIRB as high as possible, especially on small vessels. This will help ensure operation of the hydrostatic float-free release unit, in the event the vessel capsizes without sinking;	Page 7	Pass
A recommendation to limit self-testing to the minimum necessary to	Page 12	Pass

Required information for Equipment Manual	Reference on Equipment Manual page	Result
ensure confidence in the operation of the satellite EPIRB		
A warning to limit testing to the first five minutes of the hour, as the satellite EPIRB emits a 121.5 MHz signal during self-test	Page 12	Pass
If appropriate a list of approved external GNSS Receivers for those satellite EPIRBs accepting external navigation inputs together with instructions for connecting and setting up the external devices	Not applicable for this satellite EPIRB	-
If appropriate for those satellite EPIRBs with an integral GNSS receiver or that can be interfaced with an external GNSS receiver, information to guide the operator towards maximizing self-locating performance including a warning not to obstruct the GNSS antenna's view of the sky	Page 10, 14	Pass
Information explaining the necessity to report satellite EPIRB false alarms	Page 11	Pass

ANNEX 27.
INSTALLATION TEST

Equipment Under Test (EUT): MT603FG

SW version: OS0021 ver 1.00 (8/12/2014)

Test Date: 05.05.2016

TEST PROGRAM

Item	Test name	Requirements	Methods
1.	Installation test	3.13 IEC 61097-2	5.13 IEC 61097-2

DESCRIPTION OF TEST:

The equipment manual shall contain instructions to ensure that the installed satellite EPIRB shall:

- a) be installed in an easily accessible position;
- b) be installed in such a manner that it is capable of meeting the requirements of this standard;
- c) have local manual activation; remote activation may also be provided from the navigating bridge, while the device is installed in the manual release arrangement.

TEST RESULT

Passed

TEST DETAILS

Requirement for installation	Instruction Manual item	Results
Installed in an easily accessible position	page 7-8	Pass
Installed in such a manner that it is capable of meeting the requirements of this standard	page 7-8	Pass
Have local manual activation; remote activation may also be provided from the navigating bridge, while the device is installed in the manual release arrangement	page 9 page 10	Pass

ANNEX 28.
MAINTENANCE CHECK

Equipment Under Test (EUT): MT603FG

SW version: OS0021 ver 1.00 (8/12/2014)

Test Date :05.05.2016

TEST PROGRAM

Item	Test name	Requirements	Methods
1.	Maintenance check	3.9 IEC 61097-2	5.9IEC 61097-2
2.	Single integral EPIRB unit check	3.2 g) IEC 61097-2	5.2 IEC 61097-2

DESCRIPTION OF TEST

As defined in 3.2 g), the satellite EPIRB is a single integral unit, which is not suited for onboard repairs.

As a consequence, the equipment shall be so constructed that it is readily accessible for inspection and testing purposes only, access to the interior of the satellite EPIRB is possible only with the use of tools.

TEST RESULT

Passed

TEST DETAILS

Requirement for installation	Results
As defined in 3.2 g), the satellite EPIRB is a single integral unit, which is not suited for onboard repairs	Pass
As a consequence, the equipment is so constructed that it is readily accessible for inspection and testing purposes only, access to the interior of the satellite EPIRB is possible only with the use of tools	Pass



Figure 28.1- EPIRB is a single integral unit