

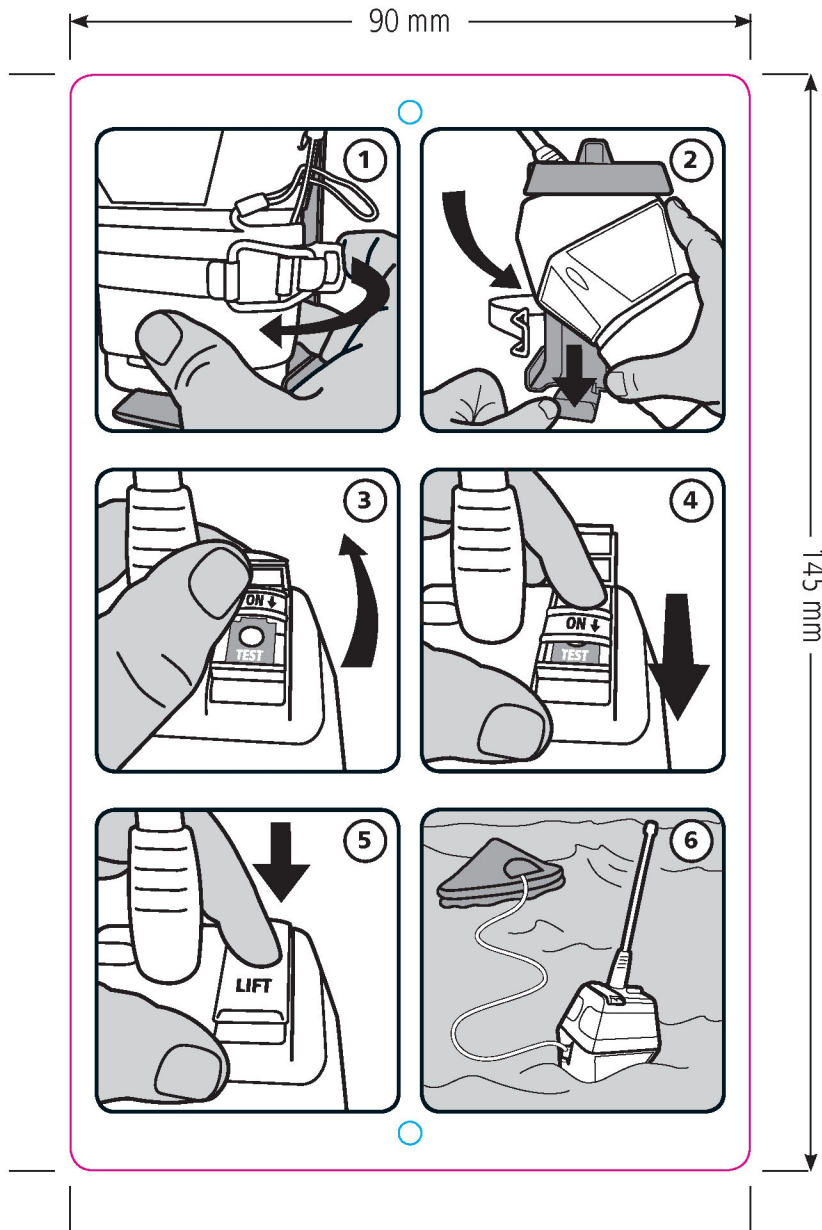

MT600 Placard

CHANGES			
Issue No.	Date	ECO No.	Changed by
2	240314	7097	BL



 Standard Communications Pty Ltd. 17 Gibbon Road, Winston Hills, NSW 2153, Australia www.gme.net.au			
Description:			
MT600 Placard			
Sheet:	Scale:	Units:	Drawn by:
1 of 1	1 : 1	mm	MS
Part Number:		Date:	
310647		24/03/2014	
Drawing Number:		Issue No:	Engineer:
47424		2	CM
File Name:			
47424-2_MT600_Placard.pdf			

CHANGES			
Issue No.	Date	ECO No.	Changed by
XXX	XX/XX/XX	XXXXXX	XXX

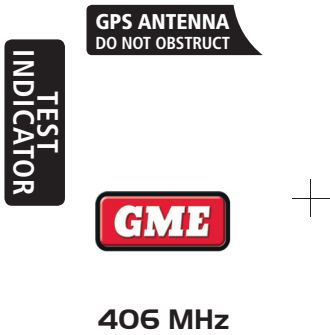

Standard Communications Pty. Ltd.			
6 Frank Street, Gladesville, NSW 2111, Australia. www.gme.net.au			
Description: MT603G_Foil_Plane			
Sheet: 1 of 1	Scale: 1 : 1	Units: mm	Drawn by: BL
Part Number: 46A0701		Date: 21/07/2011	
Drawing Number: 45740		Issue Number: 1	
File Name: 45740-1_MT603G_Foil_Plane.indd			

CHANGES			
Issue No.	Date	ECO No.	Changed by
XXX	XX/XX/XX	XXXXX	XXX

TEST
INDICATOR



+

406 MHz

Standard Communications Pty. Ltd.			
6 Frank Street, Gladesville, NSW 2111, Australia. www.gme.net.au			
Description: MT600_Foil_Plane			
Sheet: 1 of 1	Scale: 1 : 1	Units: mm	Drawn by: BL
Part Number: 46A0700		Date: 21/07/2011	
Drawing Number: 45739		Issue Number: 1	
File Name: 45739-1_MT600_Foil_Plane.indd			

OPERATION Enclosed EPIRB auto-releases then activates upon submersion to 4m (13ft)	EPIRB INFORMATION Model: MT603FG Compass Safe: 0.7m (2.3ft)	UIN(15HEX): 192DF380C6FFBFF COUNTRY: Albania Operating: -20°C to +55°C (-4°F to +131°F) Type: C/S Class2 Water Act + GPS	REPLACE BATTERY LiSO2 OCT 2025	 0062/14	 S/N 1410407582
---	---	---	---	--	---

Reference oscillator type and technical data

Oscillator Specification: E5344LF(T)

Issue 1, 24th February 2010

Designed for use in "Cospas-Sarsat" Emergency Beacon Applications

Outline in mm

Pad Connections

1. Do not connect
2. NC
3. Do not connect
4. GND
5. RF Output
6. NC
7. NC
8. Tri-State Control (Enable)*
9. Supply, +Vs
10. Do not connect

* leave unconnected if not required

Weight 170mg (typical)

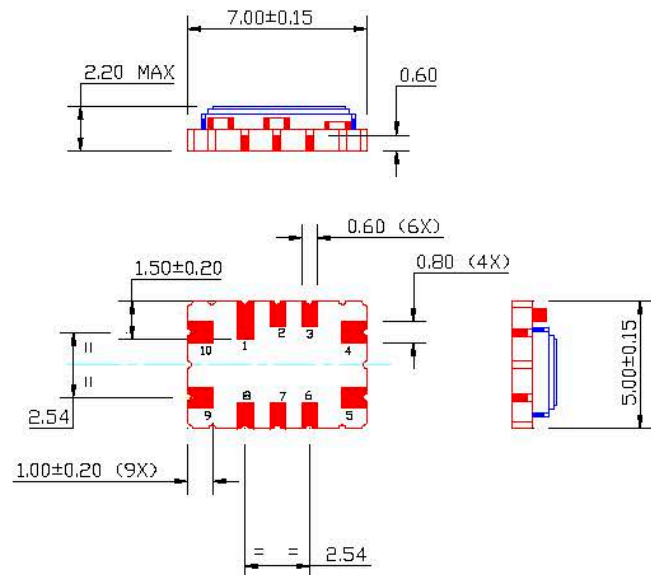

Marking includes

- Manufacturers ID (R)
- Manufacturing identifier (X XX)
- Pad 1 / Static sensitivity identifier (Δ)
- Abbreviated P/N (5344)
- Device date code (YW)
- Serial number (nnnn)

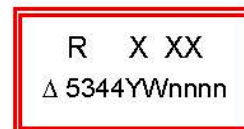

Electrical

Nominal Frequency, F_0	12.688750 MHz
Supply Voltage, V_s	3.3 V \pm 10%
Input Current	\leq 4.0 mA
Output:	
Type	HCMOS
Load	15 pF
V_{ol}	\leq 0.1 * V_s
V_{oh}	\geq 0.9 * V_s
Duty cycle @ 50%	45% to 55%
Rise time, 10% to 90%	\leq 8 ns
Fall time, 90% to 10%	\leq 8 ns
Frequency Stability	
Calibration Tolerance at 25°C	\leq \pm 0.5 ppm
Temperature, -20°C to 55°C	\leq \pm 0.2 ppm reference to $(F_{MAX}+F_{MIN})/2$
Supply Voltage, \pm 10%	\leq \pm 0.1 ppm reference to frequency at 3.3V
Load, \pm 5pF	\leq \pm 0.1 ppm reference to frequency at 15 pF
Allan Variance (tau=100ms)	\leq 1.0 ppb



Oscillator Specification: E5344LF(T)

Issue 1, 24th February 2010

Designed for use in "Cospas-Sarsat" Emergency Beacon Applications

Medium Term Stability specified and measured according to C/S T.001 & T.007* (averaged over 18 measurements in 15 minute period, and following 15 minute power up period)

Mean Slope dF/dt	
Steady state conditions	$\leq \pm 0.7$ ppb/min
During and 15 minutes after variable temperature conditions	$\leq \pm 1.7$ ppb/min (dT/dt $\leq \pm 5^{\circ}\text{C} / \text{hour}$)
Residual dF from slope	$\leq \pm 2.0$ ppb (dT/dt $\leq \pm 5^{\circ}\text{C} / \text{hour}$)
Test results shipped with each device, identified by date and serial number, retained for 10 years.	
Reflow soldering	$\leq \pm 1.0$ ppm
Ageing, first year	$\leq \pm 1.0$ ppm
Ageing, 10 years	$\leq \pm 3.0$ ppm
Tri-State	
Pad 8 open circuit or $\geq 0.6\text{Vs}$	Output Enabled
Pad 8 $\leq 0.2\text{Vs}$	Output High impedance
In Tri-state mode, the output stage is disabled but the oscillator and compensation circuit are still active (current consumption 1mA typ.).	
Phase Noise (typical values)	-90 dBc/Hz at 10 Hz -115 dBc/Hz at 100 Hz -127 dBc/Hz at 1 kHz -137 dBc/Hz at 10 kHz -143 dBc/Hz at 100 kHz

Environmental

Operating Temperature Range	-20 to +55°C
Storage Temperature Range	-55 to +125°C
Vibration	IEC 60068-2-6 Test Fc, 10-60Hz 1.5mm displacement, at 98.1 ms ⁻² , 30 minutes in each of three mutually perpendicular axes at 1 octave per minute
Shock	IEC 60068-2-27 Test Ea, 980ms ⁻² acceleration for 6ms duration, 3 shocks in each direction along three mutually perpendicular axes
Soldering	SMD product suitable for Convection Reflow soldering. Peak temperature 260°C. Maximum time above 220°C, 60 secs.
Solderability	MIL-STD-202, Method 208, Category 3
RoHS	Parts are fully compliant with the European Union directive 2002/95/EC on the restriction of the use of certain hazardous substances in electrical and electronic equipment. Note these RoHS compliant parts are suitable for assembly using both Lead-free solders and Tin/Lead solders.
Marking	Laser Marked
Packaging	Parts ordered with suffix 'T' are supplied on Tape-and-Reel.

* COSPAS SARSAT 406MHz distress beacons specification C/S T.001 (Issue 3, Revision 9, OCT 2008) and C/S T.007 (Issue 4, Revision 3, OCT 2008)

Report on oscillator ageing



TEST REPORT

Report number	2012-137
Date of issue	26th November 2012
Product description	Temperature Compensated Crystal Oscillator (TCXO)
Product type	CFPT-9000
Rakon Part number	E5344LFT
Construction	Surface mount; 7.0x5.0mm, 10-pad
Output Frequency	12.688750 MHz
Class	II
Number tested	20

TESTS PERFORMED

Mid Term Frequency stability (MTS) measurements are made over a 6-month period. This data is used to predict the performance of the device over a 10-year period.

- Test sequence
- 1) Measure MTS over the temperature range -20°C to +55°C to -20°C
 - 2) Store for 1-month at room temperature (+20°C ± 5°C)
 - 3) Measure MTS over the temperature range -20°C to +55°C to -20°C
 - 4) Store for 1-month at room temperature (+20°C ± 5°C)
 - 5) Repeat testing & storage sequence for a further 4 months

This data was collected between February & July 2010.

Applicable standard

Cospas-Sarsat T.007, issue 4, revision 6

SUMMARY OF TEST RESULTS

TEST	PASS	FAIL	REMARKS
Residual (10-year prediction)	20	0	Minimum Cpk = 2.85
Minimum Static Slope (10-year prediction)	20	0	Minimum Cpk = 5.26
Maximum Static Slope (10-year prediction)	20	0	Minimum Cpk = 11.89
Minimum Gradient Slope (10-year prediction)	20	0	Minimum Cpk = 1.42
Maximum Gradient Slope (10-year prediction)	20	0	Minimum Cpk = 1.40
Aging Mid Frequency (10-year prediction)	20	0	Minimum Cpk = 27.62

CONCLUSIONS

The conclusion reached following the analysis of the data contained within this report indicates that the failure rate for this product after 10-years operation will be less than 3500 ppm.

Testing conducted by
Report prepared by
Report approved by

Ian Payne
David R Woodall
David R Woodall

THE COPYRIGHT IN THIS DOCUMENT IS THE PROPERTY OF RAKON UK LIMITED AND THE DOCUMENT IS ISSUED ON CONDITION THAT IT IS NOT COPIED, REPRINTED OR REPRODUCED, NOR ITS CONTENTS DISCLOSED EITHER WHOLLY OR IN PART TO ANY THIRD PARTY WITHOUT EITHER THE CONSENT IN WRITING OF, OR IN ACCORDANCE WITH THE CONDITIONS OF A CONTRACT WITH RAKON UK LTD. ©

Rakon UK Limited

T +44(0)1522 812 600, F +44(0)1522 812 660, Email: info@rakon.co.uk

Dowsett House, Sadler Road, Lincoln, LN6 3RS, England

Registered Office: Dowsett House, Sadler Road, Lincoln, LN6 3RS, England

Registered in England and Wales. Registered Number: 05128090

www.rakon.com



MEDIUM TERM FREQUENCY STABILITY (MTS) - 10-YEAR PREDICTION

Device: E5344LFT	Frequency: 12.688750 MHz	Class: II	Package: SM (7x5.0mm),10-pad	Date: 26-Nov-2012
----------------------------	------------------------------------	---------------------	--	-----------------------------

RESIDUAL (ppb)

Serial Number / Time (Days)	RESIDUAL (ppb)						Slope	Intercept	Predicted Residual after 10 years
	1	30	60	90	150	180			
1	1.07	1.04	0.61	0.45	0.53	0.55	-0.268	1.138	0.185
3	1.06	1.53	1.07	1.00	1.01	1.10	-0.024	1.166	1.082
7	0.64	0.64	0.63	0.62	0.65	0.62	-0.005	0.641	0.624
9	0.38	0.41	0.21	0.31	0.54	0.67	0.063	0.318	0.544
11	0.43	0.43	0.21	0.39	0.56	0.60	0.038	0.376	0.511
13	0.59	0.70	0.61	0.80	0.82	0.77	0.089	0.573	0.888
17	1.34	1.36	1.38	0.56	0.89	1.39	-0.140	1.379	0.879
19	0.59	0.53	0.48	0.53	0.52	0.54	-0.030	0.580	0.473
21	1.62	1.36	0.73	1.13	0.89	0.99	-0.319	1.632	0.497
27	1.27	1.21	0.80	0.98	1.24	1.66	0.018	1.165	1.228
29	0.72	0.80	0.62	0.86	0.83	0.74	0.028	0.717	0.816
31	0.73	0.91	0.64	0.62	0.74	0.93	0.017	0.735	0.794
33	0.89	0.95	0.82	0.96	1.00	1.45	0.123	0.814	1.253
37	0.57	0.59	0.29	1.09	0.82	0.76	0.113	0.505	0.908
44	0.63	0.60	0.55	0.68	0.74	0.74	0.041	0.592	0.736
46	0.90	0.95	0.89	0.85	0.82	0.87	-0.026	0.922	0.829
52	0.43	0.39	0.47	0.38	0.48	0.67	0.051	0.388	0.570
54	0.77	0.76	0.68	0.78	0.82	0.73	-0.002	0.760	0.752
56	0.53	0.53	0.35	0.49	0.63	0.56	0.009	0.500	0.533
60	0.92	0.77	0.65	0.65	0.63	0.97	-0.073	0.882	0.623
							Maximum		1.253
							Minimum		0.185
							Mean		0.736
							Standard Deviation		0.265
							Upper Spec. Limit		3.000
								2 Sigma (95% Conf.)	3 Sigma (99% Conf.)
							Calc. Max. value	1.266	1.531
							Cpk (Upper)	n/a	2.850



MEDIUM TERM FREQUENCY STABILITY (MTS) - 10-YEAR PREDICTION

Device: E5344LFT	Frequency: 12.688750 MHz	Class: II	Package: SM (7x5.0mm),10-pad	Date: 26-Nov-2012
----------------------------	------------------------------------	---------------------	--	-----------------------------

MINIMUM STATIC SLOPE (ppb/min)

Serial Number / Time (Days)							Predicted Minimum Static Slope after 10 years		
	1	30	60	90	150	180	Slope	Intercept	
1	-0.03	-0.01	-0.01	-0.01	-0.03	-0.03	0.002	-0.024	-0.016
3	-0.11	-0.10	-0.13	-0.12	-0.14	-0.13	-0.011	-0.104	-0.143
7	-0.17	-0.15	-0.25	-0.17	-0.15	-0.16	0.000	-0.176	-0.174
9	-0.08	-0.08	-0.09	-0.07	-0.08	-0.08	0.001	-0.081	-0.079
11	-0.15	-0.14	-0.14	-0.14	-0.13	-0.14	0.006	-0.150	-0.128
13	-0.08	-0.08	-0.08	-0.07	-0.08	-0.07	0.003	-0.081	-0.071
17	-0.19	-0.13	-0.01	-0.01	-0.02	-0.03	0.082	-0.197	0.095
19	-0.08	-0.11	-0.14	-0.10	-0.09	-0.09	-0.007	-0.090	-0.116
21	-0.11	-0.12	-0.08	-0.08	-0.09	-0.08	0.014	-0.115	-0.067
27	-0.08	-0.08	-0.03	-0.05	-0.04	-0.07	0.014	-0.081	-0.031
29	-0.05	-0.05	-0.11	-0.06	-0.07	-0.08	-0.013	-0.049	-0.095
31	-0.08	-0.09	-0.08	-0.08	-0.07	-0.09	0.000	-0.082	-0.081
33	-0.02	-0.06	-0.09	-0.02	-0.05	-0.08	-0.018	-0.024	-0.088
37	-0.10	-0.09	-0.13	-0.10	-0.10	-0.11	-0.004	-0.099	-0.112
44	-0.05	-0.06	-0.05	-0.05	-0.06	-0.06	-0.003	-0.050	-0.061
46	-0.08	-0.09	-0.07	-0.07	-0.07	-0.07	0.005	-0.084	-0.065
52	-0.06	-0.10	-0.12	-0.11	-0.12	-0.11	-0.025	-0.062	-0.153
54	-0.06	-0.08	-0.11	-0.07	-0.08	-0.10	-0.013	-0.062	-0.110
56	-0.08	-0.11	-0.09	-0.11	-0.11	-0.11	-0.013	-0.081	-0.127
60	-0.04	-0.06	-0.07	-0.08	-0.06	-0.07	-0.014	-0.042	-0.090
							Maximum		0.095
							Minimum		-0.174
							Mean		-0.086
							Standard Deviation		0.058
							Upper Spec. Limit		1.000
							Lower Spec. Limit		-1.000
							2 Sigma (95% Conf.)		sigma (99% Conf.)
							Calc. Max. value	0.030	0.088
							Calc. Min. value	-0.201	-0.259
							Cpk (Upper)	n/a	6.250
							Cpk (Lower)	n/a	5.265



MEDIUM TERM FREQUENCY STABILITY (MTS) - 10-YEAR PREDICTION				
Device: E5344LFT	Frequency: 12.688750 MHz	Class: II	Package: SM (7x5.0mm),10-pad	Date: 26-Nov-2012
MAXIMUM STATIC SLOPE (ppb/min)				

Serial Number / Time (Days)							Predicted Maximum Static Slope after 10				
	1	30	60	90	150	180	Slope	Intercept	years		
1	0.10	0.08	0.19	0.08	0.12	0.09	0.005	0.103	0.119		
3	0.12	0.06	0.11	0.07	0.06	0.10	-0.017	0.114	0.054		
7	0.05	0.06	0.05	0.06	0.05	0.07	0.004	0.050	0.065		
9	0.04	0.05	0.02	0.02	0.05	0.07	0.004	0.035	0.049		
11	0.08	0.08	0.05	0.07	0.07	0.11	0.001	0.074	0.080		
13	0.06	0.04	0.05	0.08	0.05	0.08	0.004	0.053	0.068		
17	0.23	0.21	0.14	0.13	0.11	0.10	-0.057	0.245	0.041		
19	0.06	0.09	0.03	0.17	0.05	0.06	0.007	0.066	0.090		
21	0.08	0.10	0.06	0.09	0.07	0.08	-0.002	0.084	0.075		
27	0.12	0.07	0.07	0.10	0.16	0.12	0.004	0.100	0.114		
29	0.09	0.07	0.05	0.08	0.09	0.08	-0.004	0.083	0.069		
31	0.06	0.06	0.05	0.05	0.06	0.11	0.008	0.052	0.080		
33	0.11	0.07	0.12	0.12	0.13	0.12	0.008	0.099	0.127		
37	0.07	0.07	0.04	0.11	0.10	0.08	0.009	0.063	0.096		
44	0.01	0.04	0.02	0.03	0.02	0.05	0.010	0.012	0.049		
46	0.06	0.05	0.05	0.08	0.05	0.06	0.000	0.058	0.059		
52	0.05	0.05	0.08	0.07	0.05	0.08	0.009	0.049	0.081		
54	0.05	0.07	0.03	0.06	0.05	0.09	0.007	0.048	0.071		
56	0.04	0.05	0.03	0.04	0.06	0.04	0.002	0.039	0.048		
60	0.17	0.14	0.19	0.13	0.15	0.11	-0.016	0.174	0.116		
							Maximum		0.127		
							Minimum		0.041		
							Mean		0.078		
							Standard Deviation		0.026		
							Upper Spec. Limit		1.000		
							Lower Spec. Limit		-1.000		
								2 Sigma (95% Conf.)		3 Sigma (99% Conf.)	
							Calc. Max. value		0.129		0.155
							Calc. Min. value		0.026		0.000
							Cpk (Upper)		n/a		11.894
							Cpk (Lower)		n/a		13.897



MEDIUM TERM FREQUENCY STABILITY (MTS) - 10-YEAR PREDICTION				
Device: E5344LFT	Frequency: 12.688750 MHz	Class: II	Package: SM (7x5.0mm),10-pad	Date: 26-Nov-2012
MINIMUM GRADIENT SLOPE (ppb/min)				

Serial Number / Time (Days)							Predicted Minimum Gradient Slope after		
	1	30	60	90	150	180	Slope	Intercept	10 years
1	-1.01	-0.91	-0.90	-0.92	-0.93	-0.95	0.035	-0.993	-0.869
3	-1.01	-1.00	-1.07	-1.00	-0.99	-1.04	-0.005	-1.011	-1.027
7	-0.73	-0.72	-0.78	-0.72	-0.72	-0.74	-0.002	-0.732	-0.739
9	-0.52	-0.50	-0.49	-0.50	-0.50	-0.49	0.012	-0.519	-0.477
11	-0.20	-0.17	-0.22	-0.18	-0.20	-0.22	-0.004	-0.192	-0.206
13	-0.33	-0.28	-0.25	-0.25	-0.24	-0.23	0.043	-0.333	-0.179
17	-0.49	-0.45	-0.60	-0.45	-0.52	-0.55	-0.019	-0.480	-0.547
19	-0.69	-0.66	-0.64	-0.65	-0.66	-0.65	0.018	-0.687	-0.624
21	-1.18	-1.16	-1.16	-1.15	-1.17	-1.19	0.003	-1.173	-1.162
27	-0.97	-0.94	-0.83	-0.90	-1.05	-1.09	-0.023	-0.927	-1.008
29	-0.99	-0.95	-0.94	-0.96	-0.95	-0.94	0.020	-0.987	-0.916
31	-0.83	-0.83	-0.83	-0.84	-0.75	-0.79	0.019	-0.843	-0.774
33	-1.01	-1.03	-0.98	-1.00	-1.03	-1.05	-0.007	-1.005	-1.031
37	-0.26	-0.26	-0.25	-0.26	-0.27	-0.34	-0.016	-0.248	-0.305
44	-0.47	-0.49	-0.54	-0.58	-0.53	-0.55	-0.038	-0.465	-0.601
46	-0.84	-0.83	-0.79	-0.76	-0.71	-0.75	0.048	-0.857	-0.686
52	-0.42	-0.42	-0.44	-0.46	-0.49	-0.48	-0.028	-0.407	-0.505
54	-0.97	-1.00	-1.01	-1.01	-1.03	-1.04	-0.028	-0.966	-1.064
56	-0.35	-0.33	-0.35	-0.37	-0.35	-0.39	-0.010	-0.340	-0.377
60	-0.35	-0.27	-0.29	-0.27	-0.25	-0.30	0.034	-0.342	-0.223
							Maximum		-0.179
							Minimum		-1.162
							Mean		-0.666
							Standard Deviation		0.312
							Upper Spec. Limit		2.000
							Lower Spec. Limit		-2.000
								2 Sigma (95% Conf.)	3 Sigma (99% Conf.)
							Calc. Max. value	-0.042	0.270
							Calc. Min. value	-1.290	-1.602
							Cpk (Upper)	n/a	2.849
							Cpk (Lower)	n/a	1.426



MEDIUM TERM FREQUENCY STABILITY (MTS) - 10-YEAR PREDICTION				
Device: E5344LFT	Frequency: 12.688750 MHz	Class: II	Package: SM (7x5.0mm),10-pad	Date: 26-Nov-2012
MAXIMUM GRADIENT SLOPE (ppb/min)				

Serial Number / Time (Days)							Predicted Maximum Gradient Slope after		
	1	30	60	90	150	180	Slope	Intercept	10 years
1	1.26	0.92	0.97	1.00	1.02	1.02	-0.111	1.210	0.814
3	1.06	1.04	1.01	1.04	1.06	1.05	-0.006	1.052	1.032
7	0.55	0.57	0.60	0.63	0.66	0.68	0.052	0.532	0.716
9	0.45	0.44	0.45	0.44	0.43	0.43	-0.008	0.452	0.425
11	0.19	0.19	0.18	0.19	0.20	0.20	0.003	0.187	0.198
13	0.19	0.19	0.17	0.17	0.17	0.18	-0.008	0.191	0.163
17	1.05	1.06	0.39	0.48	0.52	0.54	-0.270	1.108	0.144
19	0.69	0.68	0.69	0.74	0.69	0.70	0.007	0.687	0.712
21	1.14	1.17	1.16	1.15	1.16	1.18	0.012	1.141	1.183
27	0.69	0.67	0.49	0.45	0.45	0.49	-0.109	0.715	0.327
29	0.99	0.95	0.92	0.92	0.93	0.93	-0.030	0.988	0.882
31	0.86	0.85	0.86	0.91	0.78	0.77	-0.024	0.878	0.791
33	1.08	1.05	1.06	1.06	1.07	1.09	-0.002	1.071	1.065
37	0.28	0.26	0.23	0.24	0.24	0.24	-0.020	0.280	0.210
44	0.44	0.46	0.49	0.51	0.52	0.55	0.042	0.427	0.577
46	0.97	0.87	0.60	0.62	0.62	0.65	-0.166	0.988	0.398
52	0.38	0.39	0.38	0.40	0.41	0.42	0.014	0.374	0.424
54	0.95	0.95	0.95	0.95	0.96	0.97	0.005	0.946	0.965
56	0.33	0.33	0.37	0.37	0.39	0.40	0.029	0.319	0.421
60	0.25	0.26	0.23	0.22	0.22	0.21	-0.017	0.258	0.199
							Maximum		1.183
							Minimum		0.144
							Mean		0.582
							Standard Deviation		0.336
							Upper Spec. Limit		2.000
							Lower Spec. Limit		-2.000
								2 Sigma (95% Conf.)	3 Sigma (99% Conf.)
							Calc. Max. value	1.254	1.589
							Calc. Min. value	-0.089	-0.425
							Cpk (Upper)	n/a	1.408
							Cpk (Lower)	n/a	2.564



MEDIUM TERM FREQUENCY STABILITY (MTS) - 10-YEAR PREDICTION				
Device: E5344LFT	Frequency: 12.688750 MHz	Class: II	Package: SM (7x5.0mm),10-pad	Date: 26-Nov-2012
AGING - MID FREQUENCY (ppm)				

Serial Number / Time (Days)	Predicted Aging-Mid Frequency after 10						Slope	Intercept	years	2 Sigma (95% Conf.)		3 Sigma (99% Conf.)	
	1	30	60	90	150	180				Calc. Max. value	Calc. Min. value	Cpk (Upper)	Cpk (Lower)
1	-0.19	-0.20	-0.18	-0.19	-0.20	-0.20	-0.003	-0.189	-0.198				
3	-0.09	-0.09	-0.12	-0.14	-0.15	-0.16	-0.029	-0.078	-0.182				
7	0.07	0.06	0.01	0.00	-0.01	-0.01	-0.037	0.080	-0.053				
9	-0.03	-0.03	-0.12	-0.14	-0.15	-0.15	-0.057	-0.011	-0.215				
11	0.00	-0.04	-0.07	-0.08	-0.09	-0.09	-0.041	0.005	-0.142				
13	0.00	0.01	-0.06	-0.07	-0.08	-0.08	-0.038	0.015	-0.121				
17	-0.06	0.06	-0.12	-0.15	-0.15	-0.15	-0.048	-0.018	-0.188				
19	0.02	0.00	-0.05	-0.06	-0.07	-0.07	-0.042	0.029	-0.121				
21	0.03	0.03	-0.03	-0.04	-0.05	-0.05	-0.038	0.042	-0.092				
27	-0.03	-0.03	-0.09	-0.10	-0.12	-0.12	-0.041	-0.015	-0.162				
29	0.03	-0.03	-0.03	-0.04	-0.04	-0.04	-0.032	0.027	-0.088				
31	-0.04	-0.05	-0.11	-0.12	-0.05	-0.05	-0.015	-0.047	-0.098				
33	-0.05	-0.05	-0.17	-0.18	-0.19	-0.20	-0.069	-0.028	-0.276				
37	0.08	0.06	0.01	0.00	-0.01	-0.01	-0.042	0.089	-0.061				
44	-0.03	-0.04	-0.10	-0.11	-0.12	-0.13	-0.044	-0.017	-0.175				
46	0.07	0.07	0.01	0.00	-0.02	-0.02	-0.041	0.085	-0.062				
52	0.00	-0.01	-0.07	-0.09	-0.09	-0.10	-0.045	0.013	-0.148				
54	0.03	0.03	-0.02	-0.03	-0.03	-0.03	-0.029	0.039	-0.066				
56	0.00	-0.01	-0.05	-0.06	-0.06	-0.06	-0.029	0.007	-0.097				
60	0.03	0.03	-0.02	-0.03	-0.04	-0.04	-0.033	0.041	-0.076				
							Maximum		-0.053				
							Minimum		-0.276				
							Mean		-0.131				
							Standard Deviation		0.061				
							Upper Spec. Limit		4.925				
							Lower Spec. Limit		-12.315				
							Calc. Max. value		-0.009			0.052	
							Calc. Min. value		-0.253			-0.314	
							Cpk (Upper)		n/a			27.624	
							Cpk (Lower)		n/a			66.566	

**The serial number of the temperature-compensated oscillator device
installed in the test beacon**



HEAD OFFICE 17 Gibbon Road, Winston Hills, NSW 2153, Australia
T (02) 8867 6000 **F** (02) 8867 6199 **SALES** 1300 463 463 **F** (02) 8867 6190
POSTAL ADDRESS PO Box 96, Winston Hills, NSW 2153, Australia
EMAIL enquiries@gme.net.au

Division of Standard Communications Pty Ltd ABN: 93 000 346 814 ACN: 000 346 814

www.gme.net.au

www.kingray.net.au

I hereby declare that Rakon Ltd. TCXO part number E5344LF, serial number NK9508 is installed in Beacon Model MT603G serial number 1410407582.

Date. 04/12/2014

Signed

A handwritten signature in black ink, appearing to read 'KWE', written over a horizontal line.

Kevan Wilson-Elswood
Technical Compliance Manager

Protection against continuous transmission

MT603 Family – Protection Against Continuous Transmit

Referring to the schematic at the end of this document;

Transmit is controlled by the Microcontroller U2 via the 406_enable line.

When the unit is NOT transmitting, the gates of Power Amplifier stages Q3 and Q4 are held at a low voltage (approximately 0.2 V) By the output of U4 via Diodes D7.

During Transmit, microcontroller U2, 406_enable line transitions from a high to Low logic level. This transition discharges C64, resulting in a low logic level to the input of inverter U4. The U4 output transitions to a high level effectively "switching off" Diodes D7, enabling the gates of Q3 and Q4 to rise to the level defined by 406_power.

In normal operation, at the end of transmit, microcontroller U2, 406 enable line returns from low logic level to high logic level. This transition results in a low to high transition at the input of U4, the output of U4 then transitioning high to low and inhibiting the Power amplifier stages Q3 and Q4.

If the microcontroller U2 develops a fault such that 406_enable remains at a logic low level, Capacitor C64 will slowly charge via R30 to the Vcc_3 voltage. When the voltage reaches approximately 1.6V, the output of U4 will transition from High to low, inhibiting the Power amplifier stages.

Frequency 5-year frequency stability



HEAD OFFICE 17 Gibbon Road, Winston Hills, NSW 2153, Australia
T (02) 8867 6000 **F** (02) 8867 6199 **SALES** 1300 463 463 **F** (02) 8867 6190
POSTAL ADDRESS PO Box 96, Winston Hills, NSW 2153, Australia
EMAIL enquiries@gme.net.au

Division of Standard Communications Pty Ltd ABN: 93 000 346 814 ACN: 000 346 814

www.gme.net.au

www.kingray.net.au

MT603G and MT603 Statement of 5 Year Frequency Stability

The TCXO, Rakon Ltd. Model E5344LF, used within GME Models MT603 and MT603G plus variants thereof will comply with the Frequency Stability requirements of C/S T.001 section 2.3.1 at an age of 5 years as attested by Rakon Document "2010_029 E5344LFT MTS 5-year prediction.xlsx"

Date. 22/03/2016

Signed

A handwritten signature in black ink, appearing to read 'Kevan Wilson-Elswood', written over a horizontal line.

Kevan Wilson-Elswood
Technical Compliance Manager

Protection against repetitive self-test



HEAD OFFICE 17 Gibbon Road, Winston Hills, NSW 2153, Australia
T (02) 8867 6000 **F** (02) 8867 6199 **SALES** 1300 463 463 **F** (02) 8867 6190
POSTAL ADDRESS PO Box 96, Winston Hills, NSW 2153, Australia
EMAIL enquiries@gme.net.au

Division of Standard Communications Pty Ltd ABN: 93 000 346 814 ACN: 000 346 814

www.gme.net.au

www.kingray.net.au

MT603(G) 406MHz EPIRB

PROTECTION FROM REPETITIVE SELF-TEST

1) Introduction

The potential for repetitive self-test emissions arises during a hardware or software malfunction involving the beacons controller circuitry.

It is more likely that such malfunctions could occur towards the end of battery life, where the supply voltage is insufficient to support reliable microprocessor operation.

2) Protection Features

The MT603 architecture and circuitry contains integral measures designed to avoid the potential occurrence of repetitive self-test emissions. Primarily these measures are aimed at ensuring that the MT603 software always executes as intended; from initial activation right through to the point where all power reserves are exhausted.

2.1 Protection of Microcontroller Operating Voltage

This feature will not allow the microcontroller to place the beacon in an operational state which will compromise its own supply voltage requirements.

During a 406MHz transmission and strobe light flashes particularly high energy demands are placed on the battery cells. The terminal voltage on a significantly depleted cell will dip whilst a high current demand is present, and subsequently recover once that demand is removed.

Voltage detection circuitry provided within the beacon continuously monitors the regulated supply voltage provided to the microcontroller. If that voltage passes down through a predefined threshold a microcontroller interrupt is generated. The interrupt service routine within the firmware immediately aborts the current 406MHz/strobe flash prior to the voltage reaching a critically low level. All transmissions and indications cease and the Microcontroller enters a shut down state. The microcontroller will not enter an operational state unless the power is fully removed and re-applied, the only means by which this can be achieved is if the operator switches the unit off/on.

In the instance of an operator initiated self-test (which normally includes a 406MHz transmission and operation of the strobe), correct microcontroller operation is ensured by this protective feature even when the battery energy reserve is nearly exhausted.

2.2 End of Life Operational mode

This feature provides for an extended operational duration of the beacon and a graceful failure as battery capacity is exhausted. By controlling the end-of-life performance the occurrence of spurious self-test (and other) messages are avoided.

During a 406 MHz transmission, or strobe flash, a high current demand of short duration is placed on the battery cells. In contrast 121.5 MHz homer operation places a much more modest, but continuous requirement on the energy source. Consequently as cells discharge they will reach a point where they are unable to service high current demands (terminal voltage collapses significantly), but could continue to support satisfactory operation of the homer transmitter.



HEAD OFFICE 17 Gibbon Road, Winston Hills, NSW 2153, Australia
T (02) 8867 6000 **F** (02) 8867 6199 **SALES** 1300 463 463 **F** (02) 8867 6190
POSTAL ADDRESS PO Box 96, Winston Hills, NSW 2153, Australia
EMAIL enquiries@gme.net.au

Division of Standard Communications Pty Ltd ABN: 93 000 346 814 ACN: 000 346 814

www.gme.net.au

www.kingray.net.au

The MT603 includes a feature which monitors the battery voltage during high current pulses.. Should the voltage fall below a pre-defined threshold on 5 consecutive pulses then:

- it is deemed that the battery cell capacity is almost exhausted
- no further 406MHz transmissions (or strobe flashes) shall be attempted
- the units audible enunciator will continue to operate to indicate that the unit is activated
- 121.5 MHz homer operation shall continue until all available energy is consumed, at which time the unit will completely cease to operate, shutting down as described in sec. 2.1

Note that if the MT603 is switched off, then on again, the limit counter will be reset and the unit will attempt to enter the normal operational mode.

3) *Conclusion*

The MT603 design incorporates a number of features which will act to prevent the occurrence of repetitive self-test transmissions.

Date. 06/12/2014

Signed

A handwritten signature in black ink, appearing to read 'KWE', written over a horizontal line.

Kevan Wilson-Elswood
Technical Compliance Manager

Self-test default values



HEAD OFFICE 17 Gibbon Road, Winston Hills, NSW 2153, Australia
T (02) 8867 6000 **F** (02) 8867 6199 **SALES** 1300 463 463 **F** (02) 8867 6190
POSTAL ADDRESS PO Box 96, Winston Hills, NSW 2153, Australia
EMAIL enquiries@gme.net.au

Division of Standard Communications Pty Ltd ABN: 93 000 346 814 ACN: 000 346 814

www.gme.net.au

www.kingray.net.au

MT603G Self-test default Location Encoding

Within the MT603 series beacons, the 406 Data Payload is “double buffered”.

Upon Power on, the message is constructed in volatile memory (lower buffer) based on the permanently encoded, internal UIN /configuration data within the Flash ROM. This permanent data includes the default location data as required by C/S.

Subsequent to this, the unit enters normal routines, monitoring the switch to sense if it is released thereby indicating a Self –Test or GNSS Self-test dependent upon the time of release. The microcontroller also monitors the NMEA messages produced by the GNSS device and if a valid position is obtained, it is encoded into the lower buffer. If the On/Off switch is released within 2 seconds of activation, indicating a ‘Self-Test’, an internal system flag is set.

As part of the normal Transmit request procedure, the contents of this lower buffer are transferred to a “Transmit buffer” immediately prior to 406 Transmission, this occurring initially after 50 seconds and thereafter as per C/S requirements. Before transferring the data between buffers the microcontroller verifies the setting of the Self-Test flag and if set, the lower buffer is flushed and re-filled with default data immediately prior to transferral to the transmit buffer and transmission.

Date. 05/12/2014

Signed

A handwritten signature in black ink, appearing to read 'KWE', written over a horizontal line.

Kevan Wilson-Elswood
Technical Compliance Manager

Protection against GNSS receiver faulty operation



HEAD OFFICE 17 Gibbon Road, Winston Hills, NSW 2153, Australia
T (02) 8867 6000 **F** (02) 8867 6199 **SALES** 1300 463 463 **F** (02) 8867 6190
POSTAL ADDRESS PO Box 96, Winston Hills, NSW 2153, Australia
EMAIL enquiries@gme.net.au

Division of Standard Communications Pty Ltd ABN: 93 000 346 814 ACN: 000 346 814

www.gme.net.au

www.kingray.net.au

MT603G EPIRB, protection against erroneous position encoding into beacon message.

C/S T.001 sec. 4.5.5.3 requires "the distance between the position provided by the navigation device, at the time of the position update, and the true beacon position shall not exceed 500 m for beacons transmitting the Standard or National location protocols. To obtain positional information beacons are dependent upon GNSS systems which inherently have statistical errors (usually of a Gaussian distribution) associated with the solution eg. Pseudo-range errors.

In the absence of statistical loadings in the C/S requirement and based on external documents eg IMO resolution A.915(22) sec. 2.1, a 95% probability that the accuracy is better than 500m was chosen for the design specification of the MT603G.

Upon power up the Antenova M10478-A2 module, by default, generates the following NMEA messages;

GGA, RMC, GSV, GSA

To determine positional information the MT603G microcontroller monitors the output of the Antenova M10478-A2, extracting and parsing the GGA message. Receipt of this message confirms the communications link and is in fact used within the standard Self-Test procedure for that same purpose.

The GGA message contains positional information together with a Horizontal Dilution of Precision (HDOP) for that calculated position and a GPS Quality Indicator amongst other parameters. The MT603G controller parses the GGA message to determine the position but will only encode the position into the 406.04MHz transmission if the GPS Quality Indicator contains the value 1, 2 or 3 indicating a valid Fix and if the HDOP is below a defined value.

To determine the HDOP "threshold" value one must review the US Department of Defense, Global Positioning System Standard Positioning Service Performance Standard 2008. From the standard;

$$UHNE = UERE \times HDOP \quad (B-2)$$

where

UHNE = User Horizontal Navigation Error (rms)

UERE = User Equivalent Range Error

The System User Range error (URE) for Satellites in Space (SIS) is shown in Table 3.4-1 and summarised below

 SIS Accuracy Standard, Single-Frequency C/A-Code:

<= 7.8 m 95% Global Average URE during Normal Operations over all AODs

<= 6.0 m 95% Global Average URE during Normal Operations at Zero AOD

<= 12.8 m 95% Global Average URE during Normal Operations at Any AOD

Notes To table 3.4-1

1. For single-frequency C/A-code URE, see Appendix A for information on how to factor in the single-frequency ionospheric delay model errors for L1. Single-frequency ionospheric delay model errors are specifically excluded from the Standard Positioning Service (SPS) SIS URE standard as an explicit constraint to emphasize they are neglected despite the fact that the single-frequency ionospheric delay model parameters are part of the broadcast SPS SIS.



Kingray

HEAD OFFICE 17 Gibbon Road, Winston Hills, NSW 2153, Australia
T (02) 8867 6000 **F** (02) 8867 6199 **SALES** 1300 463 463 **F** (02) 8867 6190
POSTAL ADDRESS PO Box 96, Winston Hills, NSW 2153, Australia
EMAIL enquiries@gme.net.au

Division of Standard Communications Pty Ltd ABN: 93 000 346 814 ACN: 000 346 814

www.gme.net.au

www.kingray.net.au

2. The “**over all AODs**” performance standards are the ones which are the most directly representative of the URE experienced by SPS receivers. See Appendix A for further information.
3. The = 7.8 m 95% SPS SIS URE performance standard is statistically equivalent to a = 4.0 m rms SPS SIS URE performance standard, assuming a normal distribution with zero mean.

 Also, noting Table A4.2;

Table A.4-2. L1 Single-Frequency C/A-Code UERE Budget

Segment	Error Source	UERE Contribution (95%) (metres)	
		Iono. Delay Model Min Max AOD in Normal Operation	Iono. Delay Model Max Max AOD in Normal Operation
Space	Clock Stability	8.9	8.9
Space	Group Delay Stability	3.1	3.1
Space	Diff'l Group Delay Stability	0	0
Space	Satellite Acceleration Uncertainty	2	2
Space	Other Space Segment Errors	1	1
Control	Clock/Ephemeris Estimation	2	2
Control	Clock/Ephemeris Prediction	6.7	6.7
Control	Clock/Ephemeris Curve Fit	0.8	0.8
Control	Iono Delay Model Terms	9.8	19.6
Control	Group Delay Time Correction	4.5	4.5
Control	Other Control Segment Errors	1	1
User*	Ionospheric Delay Compensation	N/A	N/A
User*	Tropospheric Delay Compensation	3.9	3.9
User*	Receiver Noise and Resolution	2.9	2.9
User*	Multipath	2.4	2.4
User*	Other User Segment Errors	1	1
		17.06	24.07

Notes to table A.4-2

.
 .
 .

8. Actual single-frequency ionospheric delay model errors depend on the point in the 11-year sunspot cycle, the geomagnetic location, the local solar time of day, and the local satellite elevation angle. Due to this variability, the single-frequency URE, URRE, and URAE standards do not include the single-frequency ionospheric delay model errors. **Tables A.4-2 and A.4-4 illustrate the typical method for including the single-frequency ionospheric delay model errors at L1.** See paragraph A.4.9 for additional information.

9. **The user contributions to the UERE budget illustrate mid-1980s vintage receiving equipment.** See Appendix B for additional information on different SPS receivers and environments.

10. All statistical values are expressed at the 95% probability level in accordance with international standards.



HEAD OFFICE 17 Gibbon Road, Winston Hills, NSW 2153, Australia
T (02) 8867 6000 **F** (02) 8867 6199 **SALES** 1300 463 463 **F** (02) 8867 6190
POSTAL ADDRESS PO Box 96, Winston Hills, NSW 2153, Australia
EMAIL enquiries@gme.net.au

Division of Standard Communications Pty Ltd ABN: 93 000 346 814 ACN: 000 346 814

www.gme.net.au

www.kingray.net.au

Table A.4-2 illustrates the typical method for including the single-frequency ionospheric delay model errors in the Control Segment contribution to the L1 SPS SIS URE.

It should be noted that figures in table A.4-2 are quoted at **Maximum Age of Data (AOD)**. The range errors due to age of data are represented by the Space and Control Segment contributions, excluding Ionospheric Delay Model Terms and indeed if the rms value of these contributions is calculated, it gives a result of 12.8m as indicated in table 3.4-1.

It should also be noted that Note 2 to table 3.4-1, at the beginning of this text, indicates the “**over all AODs**” performance standards are the ones which are the most directly representative of the URE experienced by SPS receivers.”

Table 3.4-1 shows the rms contribution of Space and Control segment errors “**over all AODs**” equates to 7.8m and if this is substituted into Table A.4-2, the resultant UERE when considering the Maximum Ionospheric Delay compensation is 21.825m.

Using the value of 21.825m derived above within equation B2;

$$\text{HDOP} = 500 / 21.825 = 22.91.$$

Since the User segment values within Table A.4-2 illustrate mid 1980 vintage equipment, GME feels it is safe to round this figure up to

$$\text{HDOP}_{(\text{threshold})} = 23.$$

This threshold value is programmed into the MT603G system configuration memory and is not “hard coded” into the firmware thus the value may be easily changed if C/S requirements change at a later date.

To ensure that a geographically valid position is encoded into the transmitted message, the NMEA message GGA is parsed and processed as above. It is assumed that the level of processing required within modern GNSS receivers is such that they would not generate a message with invalid Geographical co-ordinates. This is a mature market and devices with such a fundamental error of coding would not remain on the market. There does remain a possibility of corruption within the data stream between the GNSS device and the MT603G microcontroller. The output messages of the M10478-A2 GNSS device adheres to the NMEA 0183 Standard and as such all messages end with an 8-bit check sum. All messages received by the MT603G microcontroller are validated using this checksum.

Date. 05/12/2014

Signed

Kevan Wilson-Elswood
 Technical Compliance Manager

Information that confirms that the nominal output impedance of the beacon power amplifier is 50 Ohms

STANDARD COMMUNICATIONS PTY LTD
Engineering Department

Commercial-in-Confidence

Document: 46798
Revision: 2
Status: Released
Issue Date: 16-12-2014

EPIRB Model(s): MT600, MT600G, MT603 and MT603G

50 OHM INTERFACE ADAPTOR

TYPE APPROVAL SUBMISSION PREPARED FOR COSPAS/SARSAT

Document: 46798
Revision: 2
Status: Released
Issue Date: 16-12-2014
Prepared: Vince Todd
Position: Senior Design Engineer (RF)

Approved: Kevan Wilson-Elswood
Position: Technical Compliance
Manager
Date: 16-12-2014



1. INTRODUCTION

This document describes the 50 ohm interface adaptor supplied by Standard Communications for use in the testing of EPIRB Models MT600, MT600G, MT603 and MT603G (hereafter collectively referred to as 'MT600').

The MT600 is equipped with a permanently attached (integral) antenna. To obtain optimum power efficiency the 121.5MHz and 406MHz amplifier circuits are directly matched to the respective antenna impedance measured at those frequencies. In order to support laboratory measurements it is convenient to have an adaptor which presents the same antenna impedances to the power amplifiers while providing a 50 ohm interface port to which test equipment may be directly connected.

2. IMPLEMENTATION

The tape radiating element is removed from the MT600 EPIRB and the adaptor circuit connected directly at that point and also to module ground. For the purposes of clarity the method of adaptation is shown diagrammatically as BEFORE (Figure 1) and AFTER (Figure 2).

This approach has been adopted as it includes all beacon passive and active components, with only the wire radiating element ('the antenna') removed. The adaptor circuitry has been designed such that both 406MHz and 121.5MHz RF amplifiers see the same respective impedances as when the antenna element is present.

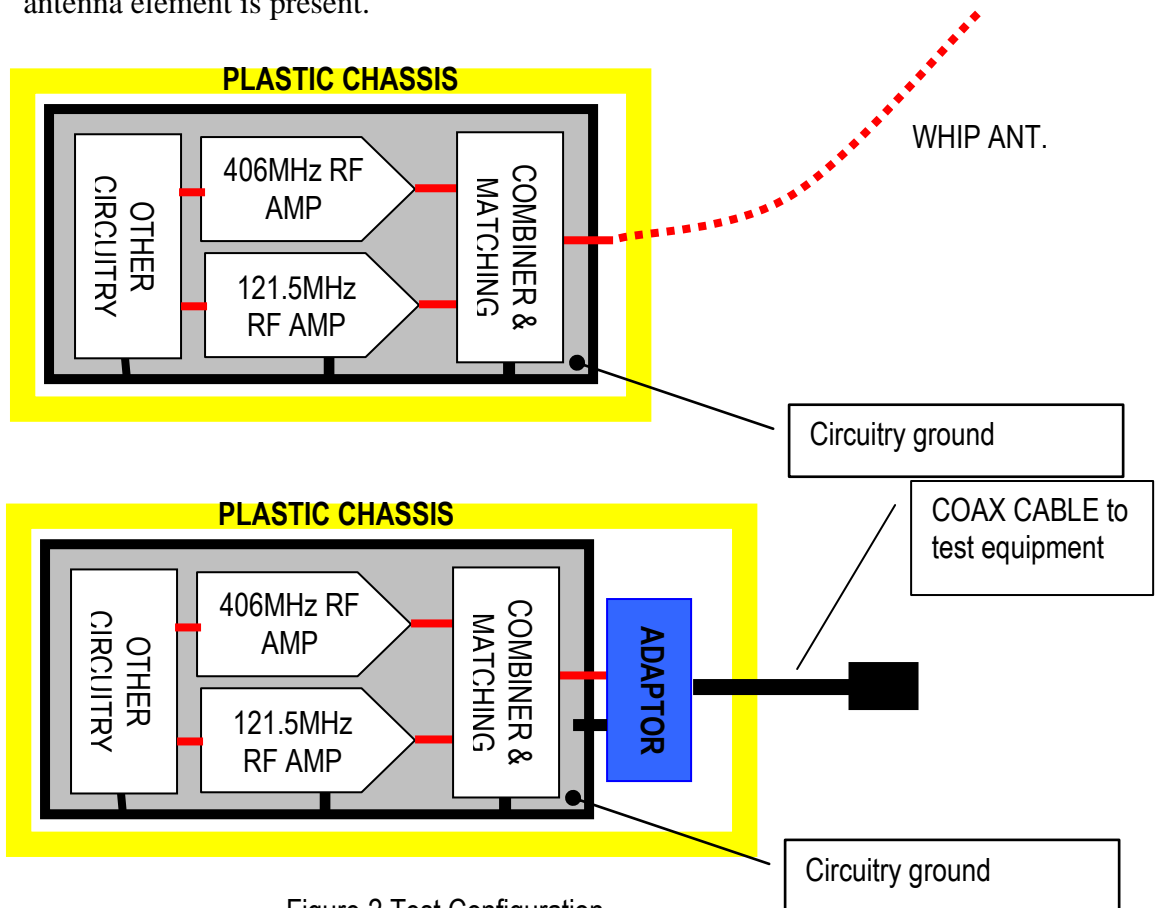

Figure 2 Test Configuration

The adaptor is constructed on a printed circuit board (part no. 580464) and has a lug at one end which couples to the EPIRB antenna bracket, and a MCX female RF connector at the other end. A short coaxial cable (RG178, 240mm. MCX-male to BNC male) is provided to connect the adaptor to the test equipment.

Earlier versions of the adaptor featured a tuneable inductor. This component proved to be susceptible to misalignment. The current version (580464-B) uses a fixed inductor and trimmer capacitor to tune the 121MHz notch.



Figure 3 antenna adaptor installed on MT600 pcb

3. TECHNICAL DESCRIPTION

3.1 Antenna Measurements

With the MT600 in a standard deployment, the antenna has been measured as presenting the following impedances at the interface with the internal circuitry:

$$Z_{121} = 2.9 - j192$$

$$Z_{406} = 72 - j8.3$$

3.2 Circuit Configuration

The circuit of Figure 4 was designed and optimised so as to present, at the respective operating frequencies, an identical complex impedance to the MT600 tape antenna assembly which it replaces.

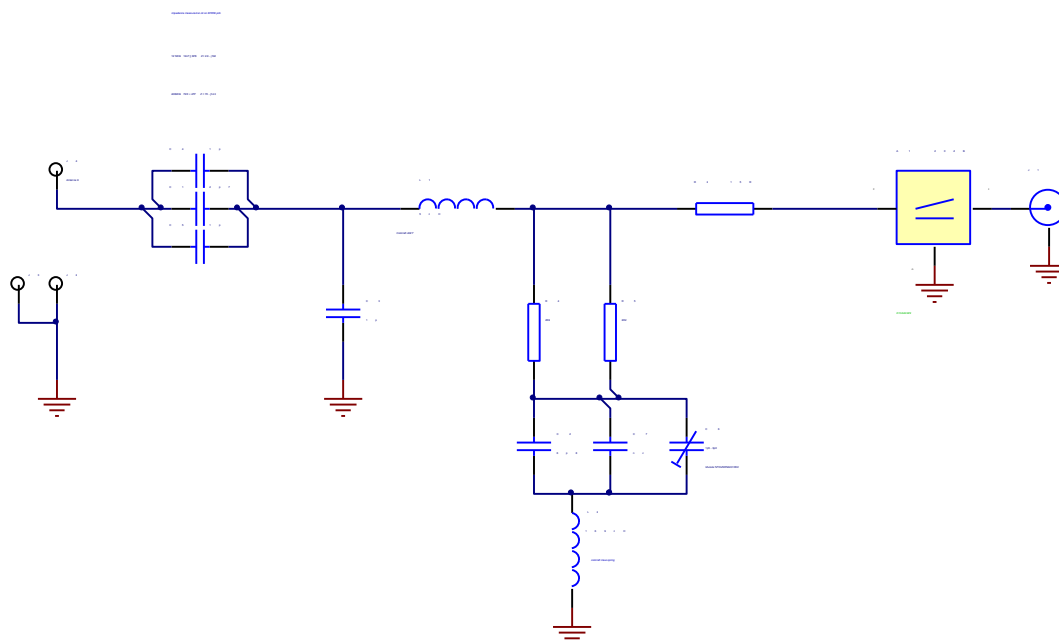

Figure 4 – MT600 50 ohm Interface Adaptor (dummy antenna)

3.3 Circuit Description

C2||C6 and L2 are series resonant at 121.5MHz. This combination presents a low, purely resistive impedance set by R4 and R5 and the resistance of L2 at 121.5MHz and a large inductive reactance at 406MHz. C1||C4||C5, when combined with the inductive reactance of L1, provides the correct net reactance at 121.5MHz.

At 406MHz the L2 and C2 have a net reactance of +j387. This is considerably larger than the shunt resistance due to R2 and the 50 ohm attenuator. This resistance, when combined with the net reactance of C1 and L1, provides the correct net impedance at 406MHz.

A theoretical design was used as a starting point. A printed circuit board was produced in order to make a circuit that could easily be reproduced. Impedance measurements were made using a Vector Network Analyser (VNA). Parasitic capacitance and inductance due to the physical arrangement of components, and finite Q of inductors, cause the measured impedance to differ from the theoretical design values. Component values were adjusted to compensate for the effects of parasitic reactances, until the measured impedances agreed with the design values. The component values shown in Figure 4 are the final values.

The antenna impedance at 121.5MHz is highly reactive, and hence the matching circuit has a very high Q. In order that the impedance presented to the MT600 circuitry is not affected by the load at J1 (ie the input VSWR of the test equipment), a 20dB attenuator was added to the antenna adaptor. This has the added benefit of dissipating most of the power in the 5W bursts, to protect sensitive test equipment.

STANDARD COMMUNICATIONS PTY LTD
Engineering Department

Commercial-in-Confidence

Document: 46798
Revision: 2
Status: Released
Issue Date: 16-12-2014

3.4 Loss Calibration at Operating Frequencies

The unit was calibrated to determine circuit, cable and attenuator losses, for the purpose of measuring transmitter power at 121.5MHz and 406MHz.

3.4.1 **Circuit loss**

Theoretical circuit losses can be calculated based on the resistive elements.

$$\begin{aligned} L_{\text{cct}121} &= -10 \cdot \log_{10} [50 \cdot ((R4 || R5) + r) / ((50 + R2) \cdot (50 + R2 + (R4 || R5) + r))] \\ &= 17.3\text{dB} \end{aligned}$$

where r is the series resistance of L2, estimated to be 0.5 ohms.

$$\begin{aligned} L_{\text{cct}406} &= -10 \cdot \log_{10} [50 / (50 + R2)] \\ &= 1.14\text{dB} \end{aligned}$$

The calculated circuit loss gives reasonable agreement with measurement at 406MHz, where parasitic losses are relatively small. At 121.5MHz, the very low series resistance makes the circuit very susceptible to measurement errors due to parasitic inductance.

To provide a more accurate estimate of the circuit losses at 121 MHz, an alternative circuit which was accurately measured, was used to calibrate the Dummy Antenna circuit loss. Details of the alternative circuit are given in Appendix A.

Circuit loss at 406MHz was measured directly using a VNA, and corrected for mismatch loss (0.37dB).

Measured circuit losses are (including attenuator)

$$L_{\text{cct}121\text{M}} = 38.9\text{dB}$$

$$L_{\text{cct}406\text{M}} = 21.4\text{dB}$$

3.4.2 **Attenuator loss**

A surface-mount attenuator element, model D10AA20Z4 (Anaren) was used. Nominal insertion loss is 20.0±0.5dB

3.4.3 **Cable loss**

A cable was supplied for testing, fitted in a modified MT600 cap. The insertion loss was measured on a VNA. (Cable description: RG178, 240mm. MCX-male to BNC male).

$$L_{\text{cab}121} = 0.12\text{dB}$$

$$L_{\text{cab}406} = 0.22\text{dB}$$

3.4.4 Total loss

$$L_{121} = L_{cab121} + L_{cct121M} = 39.0\text{dB}$$

$$L_{406} = L_{cab406} + L_{cct406M} = 21.6\text{dB}$$

3.5 Loss Calibration at Spurious Frequencies

The antenna adaptor simulates the antenna impedance accurately at the two transmit frequencies. However at other frequencies it presents impedances which might be quite different to those presented by the antenna at such frequencies. Thus it is difficult to measure the precise level of spurious emissions when using the antenna adaptor. A reasonable approximation is to measure the insertion loss of the antenna adaptor, at the spurious frequencies, in a 50-ohm measurement system. A margin of error of several dB should be assumed, but since the recorded spurious emission levels are very far below the test limit (25uW / -16dBm), this is acceptable.

Since the antenna adaptor has a reactive input impedance, it is necessary to match the input to 50 ohms in order to measure transmission loss without significant mismatch loss.

3.5.1 VHF Band

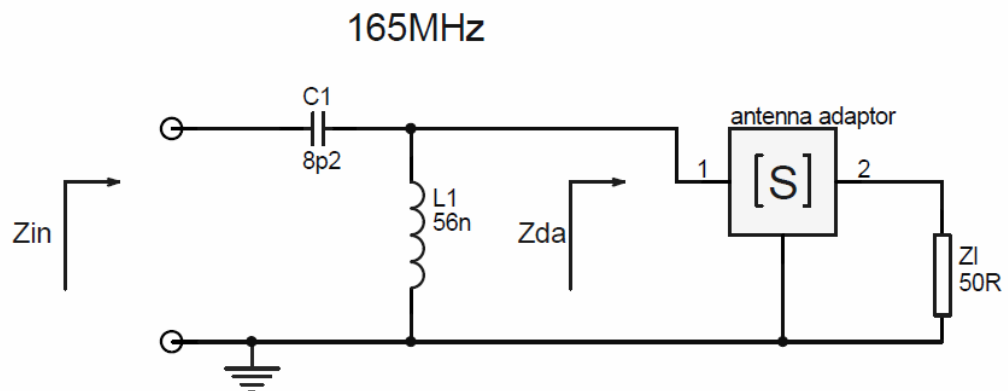

frequency / MHz	Zda / ohm	Zin / ohm	20*log s ₂₁ / dB
154	24 - j101	29.6 - j19.5	-2.6
165	30.5 - j92.4	56.7 - j2.7	-2.0
174	34.4 - j86.7	80 - j2.0	-2.0

3.5.2 GNSS Band

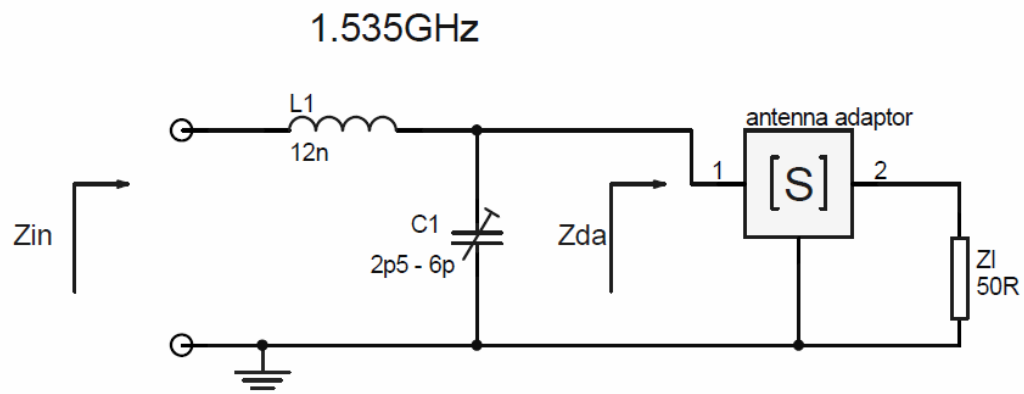

frequency / GHz	Zda / ohm	Zin* / ohm	20*log s ₂₁ / dB
1.525	9.7 + j54.2	124 + j4	-7.9
1.535	9.7 + j55.5	84 + j12	-7.7
1.545	9.4 + j56.9	56 + j28	-8.0

*Note: it is difficult to achieve a good input match to the antenna adaptor at 1.5GHz due to parasitic capacitance. However this has only a minor effect on the insertion loss.

3.6 Temperature Dependence

Temperature variations in the passive components used in the adaptor can cause errors in the transmitter power measurement. Changes to the insertion loss can be corrected simply. Changes to the input impedance of the adaptor are more difficult to correct for. These change the load presented to the power amplifier, which can change the operating condition and the power delivered to the load.

At 406MHz the impedance changes with temperature are negligible. At 121MHz, the impedance changes are significant and an indirect method was used to evaluate the temperature dependence of the antenna adaptor.

3.6.1 406MHz

Measurements show that the antenna adaptor is unchanged with temperature (within measurement error) at 406MHz. Insertion loss and input impedance were measured with a vector network analyser. Over the operating temperature range of -20°C - 55°C, the impedance change was within 1%, and the insertion loss change was 0.0 +/- 0.1dB.

STANDARD COMMUNICATIONS PTY LTD
Engineering Department

Commercial-in-Confidence

Document: 46798
Revision: 2
Status: Released
Issue Date: 16-12-2014

3.6.2 121MHz

The adaptor input impedance shows significant temperature variation at 121MHz. Thus the power measured at the output of the antenna adaptor could vary with temperature due to:

- Changes to the load on the power amplifier
- Changes in the insertion loss of the adaptor
- Other temperature-dependent changes in the RF circuitry

In order to quantify these effects, the output power was measured via the antenna adaptor over the operating temperature range. The measurement was then repeated using an RC network in place of the antenna adaptor to simulate the antenna impedance. The RC network has a negligible variation with temperature.

Into the RC network, from 25°C to -20°C the power varied by +0.4dB. From 25°C to 55°C power varied by -0.2dB.

Into the antenna adaptor the power varied by -0.7dB at -20°C and 0dB at 55°C.

Assuming that the measurements with the RC network account for all changes to RF circuitry not directly related to the antenna adaptor, the net effect of the antenna adaptor is -1.1dB at -20°C and +0.2dB at 55°C.

Temperature / °C	Correction factor @ 121MHz / dB	Correction factor @ 406MHz / dB
-20	38.5	21.6
25	37.4	21.6
55	37.2	21.6

APPENDIX A

121.5MHZ POWER MEASUREMENT

The dummy antenna simulates the measured antenna impedance at the transmission frequencies while providing a defined coupling to test instruments. The series-equivalent circuit described in this document has advantages for realising an adaptor to be used at both transmit frequencies. However, because of the high-Q nature of the 121MHz antenna impedance, the dummy antenna is susceptible to parasitics which create a degree of uncertainty in the attenuation factor to be applied when making measurements.

A parallel-equivalent circuit provides a means of verifying the attenuation factor by measurement. The effect of parasitics are predictable, measurable and can be compensated for.

The antenna impedance at 121.5MHz is $2.9 - j192$. The parallel equivalent is $12k7 \parallel 6p8$. In order to develop a measurement circuit, firstly a simple resistive divider is constructed.

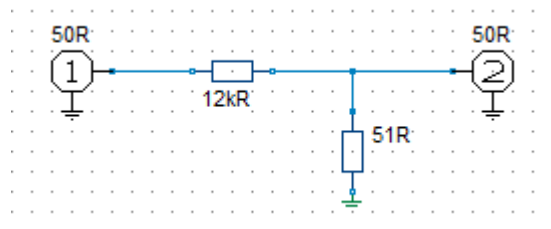

The characteristics of this circuit can be calculated:

reflection coefficient:	ρ	$= (Z_L - Z_0) / (Z_L + Z_0)$	
mag refl. coeff.	Γ	$= \rho $	$= 0.9917$
return loss	RL	$= -20 \log(\Gamma)$	$= 0.072 \text{dB}$
mismatch loss	ML	$= -10 \log(1 - \Gamma^2)$	$= 17.82 \text{dB}$
insertion loss	IL	$= **$	$= 29.75 \text{dB}$
through loss	$20 \log(s_{21})$	$= \text{ML} + \text{IL}$	$= 47.56 \text{dB}$

** insertion loss calculation:

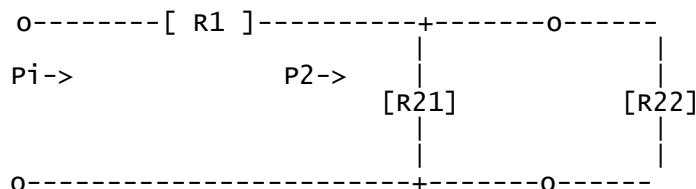

$$P_2 / P_i = R_2 / (R_1 + R_2) \quad \text{where } R_2 = R_{21} \parallel R_{22}$$

$$P_2 = P_{21} + P_{22}$$

$$P_{22} / P_2 = R_{21} / (R_{21} + R_{22})$$

$$\begin{aligned} \text{IL} &= -10 \log(P_{22} / P_i) \\ &= -10 \log\left(\frac{R_{21}}{R_{21} + R_{22}}\right) * \left(\frac{R_2}{R_1 + R_2}\right) \end{aligned}$$

STANDARD COMMUNICATIONS PTY LTD
Engineering Department

Commercial-in-Confidence

Document: 46798
Revision: 2
Status: Released
Issue Date: 16-12-2014

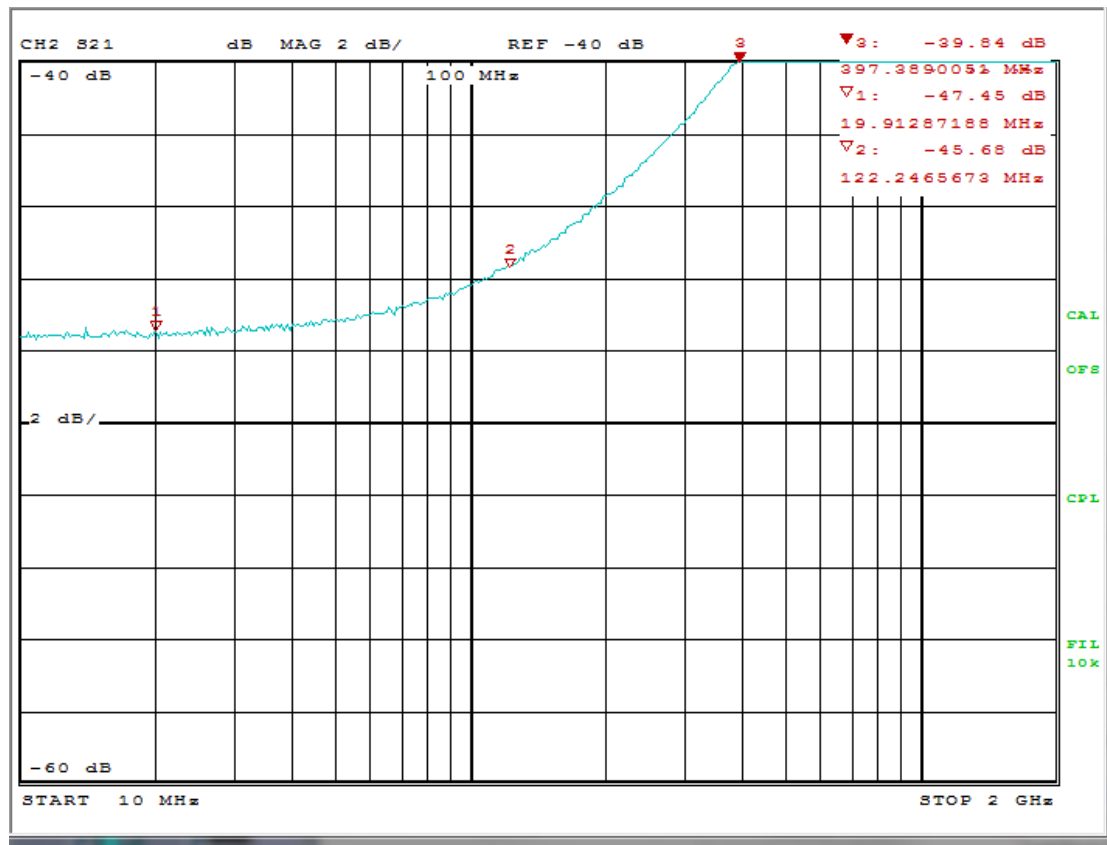

Measurement shows that the attenuation is in very close agreement with calculations up to around 20MHz. Above that, the effects of stray capacitance between the terminals of the 12k resistor are evident. This capacitance is estimated at 70fF. Its effect can be compensated out by a capacitor across the output.

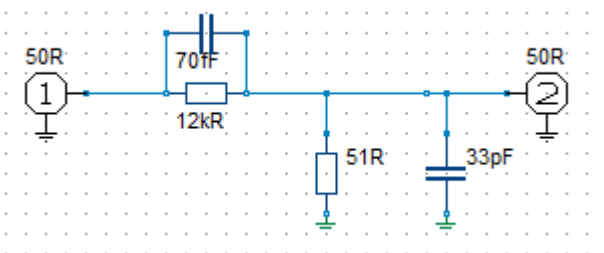

The 33pF capacitor flattens the frequency response up to around 250MHz. It also introduces a series resonance which produces a notch at 750MHz.

STANDARD COMMUNICATIONS PTY LTD
Engineering Department

Commercial-in-Confidence

Document: 46798
Revision: 2
Status: Released
Issue Date: 16-12-2014

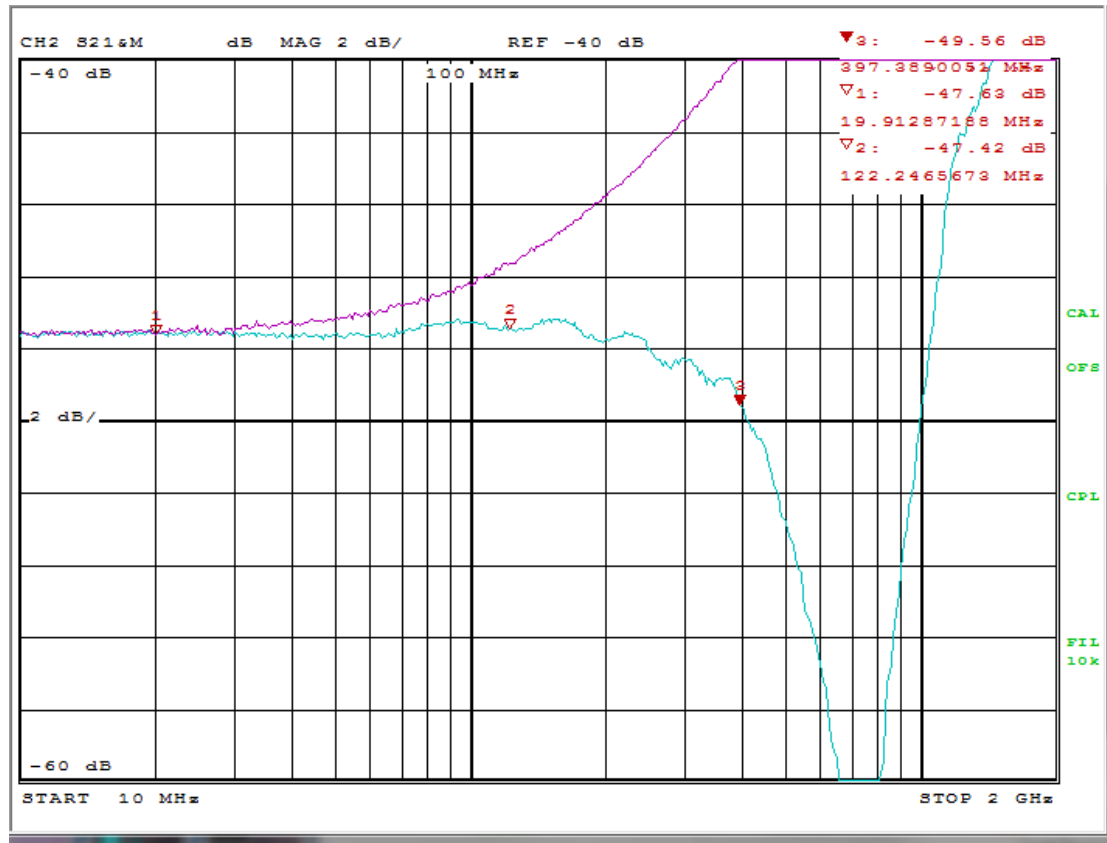

Adding a 6p8 capacitor across the input provides the correct antenna impedance. In theory it should not affect the attenuation. In practice, it is essential to isolate the ground currents of the 6p8 capacitor from the much lower currents of the resistive divider, otherwise significant measurement error will result.

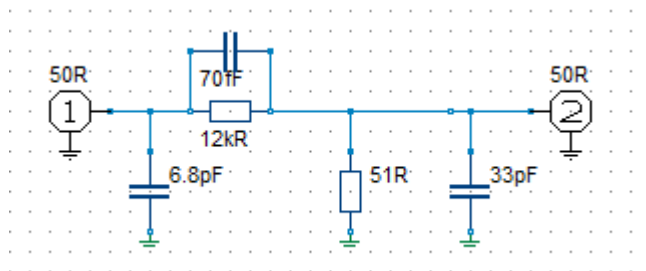

Thus a circuit has been constructed that provides the correct antenna load impedance and has an attenuation at the measurement frequency which agrees with theoretical values to within 0.1dB at the measurement frequency.

STANDARD COMMUNICATIONS PTY LTD
Engineering Department

Commercial-in-Confidence

Document: 46798
Revision: 2
Status: Released
Issue Date: 16-12-2014

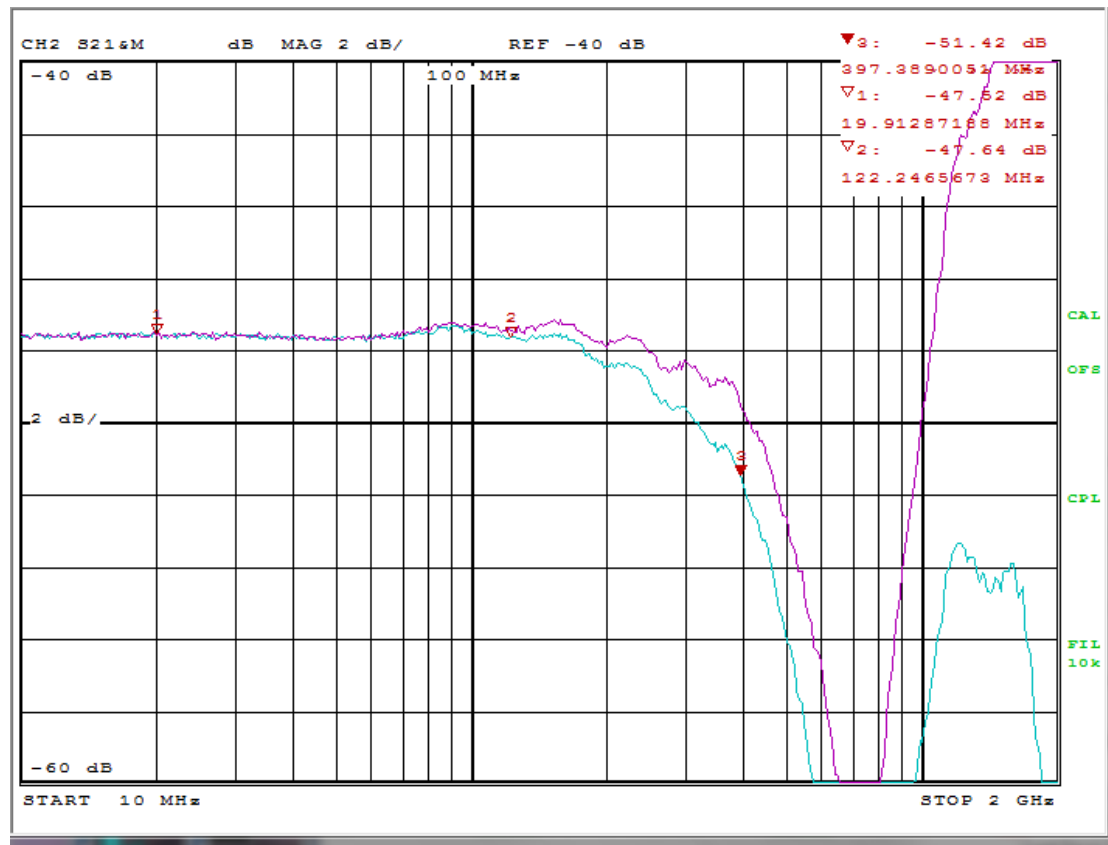

To use this circuit to check the attenuation of the dummy antenna, a substitution method is used whereby the power amplifier is operated into the reference circuit and the power is measured. Then the reference circuit is removed and the dummy antenna is substituted and again the power is measured. It is assumed that, since the impedance is the same in each case, that the power delivered to the load is the same. Since the attenuation of the reference circuit is accurately known, the dummy antenna attenuation factor can be derived.

To facilitate changing between matching circuits, the reference circuit was built up on a dummy antenna board with the same input coupling lug and ground contact fingers. Thus the reference circuit could be mounted to the MT600 board using a nylon bolt in the same way as the dummy antenna.

This introduces new parasitic effects, the most significant being ground inductance. This is difficult to reduce because of the physical arrangement, especially the spring fingers which connect the ground of the reference circuit to that of the main (MT600) pcb. The attenuation at the measurement frequency is reduced by 0.7dB to 46.9dB.

When making measurements of the power amplifier, we are concerned with the power delivered to the matching circuit. Hence the mismatch loss is not relevant, only the insertion loss. It is fair to assume that the effect of ground inductance on through loss seen in the plot below is due to increased coupling from input to output; in other words, it affects the insertion loss but not the mismatch loss. Hence the measured insertion loss for the reference circuit is $46.87 - 17.82 = 29.05\text{dB}$.

STANDARD COMMUNICATIONS PTY LTD
 Engineering Department

Document: 46798
 Revision: 2
 Status: Released
 Issue Date: 16-12-2014

Commercial-in-Confidence

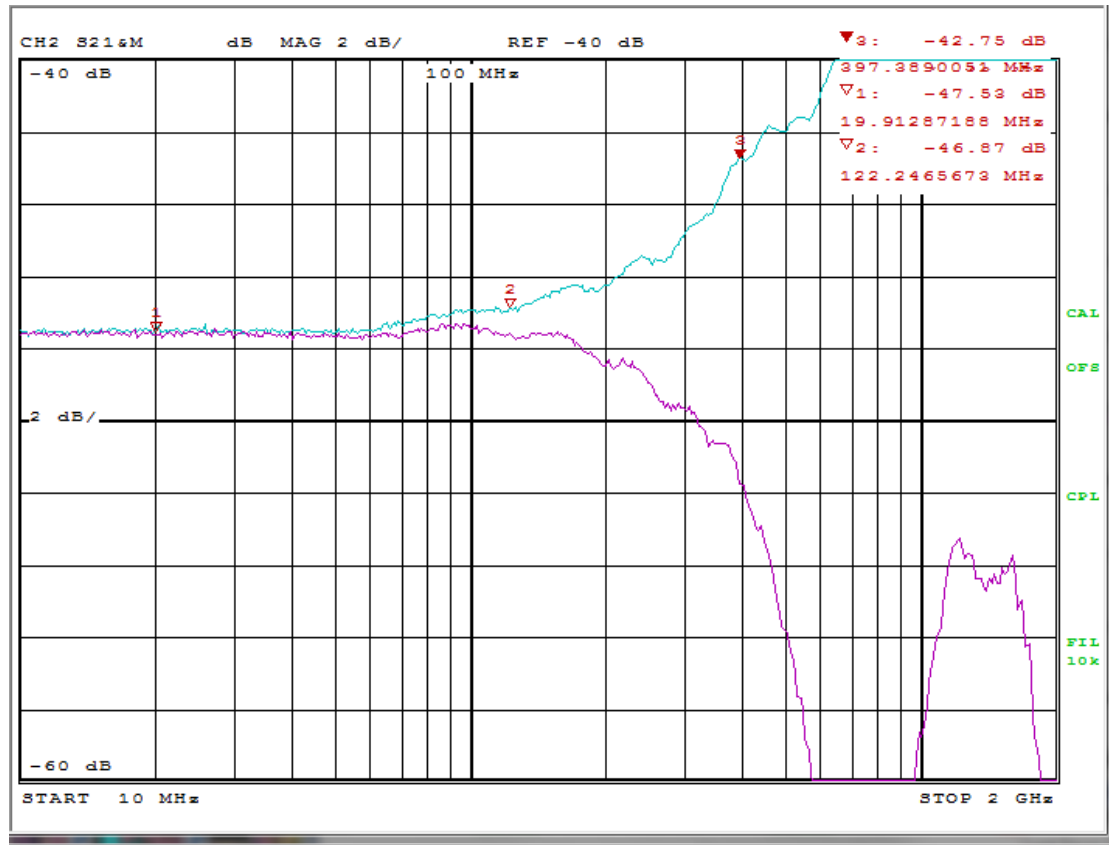

By comparing power readings for the same MT600 board with the reference circuit and the dummy antenna, the dummy antenna attenuation was determined as **38.9dB**.

GNSS receiver operating cycle and battery current



HEAD OFFICE 17 Gibbon Road, Winston Hills, NSW 2153, Australia
T (02) 8867 6000 **F** (02) 8867 6199 **SALES** 1300 463 463 **F** (02) 8867 6190
POSTAL ADDRESS PO Box 96, Winston Hills, NSW 2153, Australia
EMAIL enquiries@gme.net.au

Division of Standard Communications Pty Ltd ABN: 93 000 346 814 ACN: 000 346 814

www.gme.net.au

www.kingray.net.au

MT603G EPIRB, Modes of Operation (Including GNSS Receiver Schedule)

Beacon Performance

The MT603G model of EPIRB has no operator selectable modes of operation.

The operation of the internal GPS is automatic with no operator selectable options. This internal GPS receiver is operational from the time of activation and continues to run according to the schedule tabulated below. The initial GPS acquisition mode is a cold start, however subsequent activations of the GPS receiver after sleep, retain any received system data from prior GPS positional fixes to improve acquisition time.

This Schedule indicates the timing when the Beacon energy consumption is greatest i.e. when a GPS satellite constellation is not visible and a positional fix cannot be determined. Times are referenced to the Beacon turn on time. GPS ON times are absolute but GPS OFF times may reduce if a valid position is determined. If a valid position is determined during any GPS ON period, that data is retained by the Beacon microcontroller for inclusion in the next 406 MHz transmission and the GPS receiver is returned to a sleep mode.

If a position is determined during any wake period within the first 2 hours of operation, the GPS timing is altered from the tabulated schedule thus;

- Until 6 hours have elapsed (since Beacon power on), the navigation device “wakes” every 30 minutes for a period of 6 minutes.

Thereafter, the tabulated schedule is followed with the ultimate wake/sleep period continuing at 4 hours until end of life.

If a valid position cannot be obtained for a period of 4 hours +/- 5minutes since the last update, the transmitted position returns to default

All other functions including homing transmitter and strobe light are continuously operational, with current consumption cyclically repeating around 406MHz emissions

Date. 25/11/2015

Signed

A handwritten signature in black ink, appearing to read 'Kevan Wilson-Elswood'.

Kevan Wilson-Elswood
Technical Compliance Manager



Kingray

HEAD OFFICE 17 Gibbon Road, Winston Hills, NSW 2153, Australia
T (02) 8867 6000 **F** (02) 8867 6199 **SALES** 1300 463 463 **F** (02) 8867 6190
POSTAL ADDRESS PO Box 96, Winston Hills, NSW 2153, Australia
EMAIL enquiries@gme.net.au

Division of Standard Communications Pty Ltd ABN: 93 000 346 814 ACN: 000 346 814

www.gme.net.au

www.kingray.net.au

GPS Timing Schedule

Elapsed time hours	Elapsed time s	GPS on Time min	GPS off Time min	On duration min	Off duration min	Values at end of ON/OFF cycle	
						Cumulative On time min	Cumulative Off time min
0	0	0	8	8	7	8	7
0.25	900	15	23	8	7	16	14
0.5	1800	30	38	8	7	24	21
0.75	2700	45	53	8	7	32	28
1	3600	60	66	6	9	38	37
1.25	4500	75	81	6	9	44	46
1.5	5400	90	96	6	9	50	55
1.75	6300	105	111	6	9	56	64
2	7200	120	126	6	24	62	88
2.5	9000	150	156	6	24	68	112
3	10800	180	186	6	24	74	136
3.5	12600	210	216	6	24	80	160
4	14400	240	246	6	24	86	184
4.5	16200	270	276	6	24	92	208
5	18000	300	306	6	24	98	232
5.5	19800	330	336	6	24	104	256
6	21600	360	366	6	114	110	370
8	28800	480	486	6	114	116	484
10	36000	600	606	6	114	122	598
12	43200	720	726	6	114	128	712
14	50400	840	846	6	114	134	826
16	57600	960	966	6	114	140	940
18	64800	1080	1086	6	114	146	1054
20	72000	1200	1206	6	114	152	1168
22	79200	1320	1326	6	114	158	1282
24	86400	1440	1446	6	234	164	1516
28	100800	1680	1686	6	234	170	1750
32	115200	1920	1926	6	234	176	1984
36	129600	2160	2166	6	234	182	2218
40	144000	2400	2406	6	234	188	2452
44	158400	2640	2646	6	234	194	2686
48	172800	2880	2886	6	234	200	2920
52	187200	3120	3126	6	234	206	3154

Internal GNSS receiver and antenna data sheets

GPS RADIONOVA® RF Antenna Module

Part No. M10478-A2

Product Specification

Applications

- Personal Navigation Devices (PNDs)
- Portable Media Players (PMPs)
- Personal Digital Assistants (PDAs)
- Medical / eHealth
- Smart Watches
- Asset Tracking / Personal Safety

Features

- Easy to use, low cost single package GPS RF antenna module
- Mediatek MT3337 chip
- Ultra small SMT package; 13.8 x 9.5 x 1.8mm
- Low current consumption <200uA required for Periodic mode.
- Novel external matching ensure easy tuning for each platform
- AIC, Active Interference Cancellation for anti Jamming.
- EPO (Extended Prediction Orbit), up to 30day orbit prediction, Warm TTF = <5sec

Functional Block Diagram

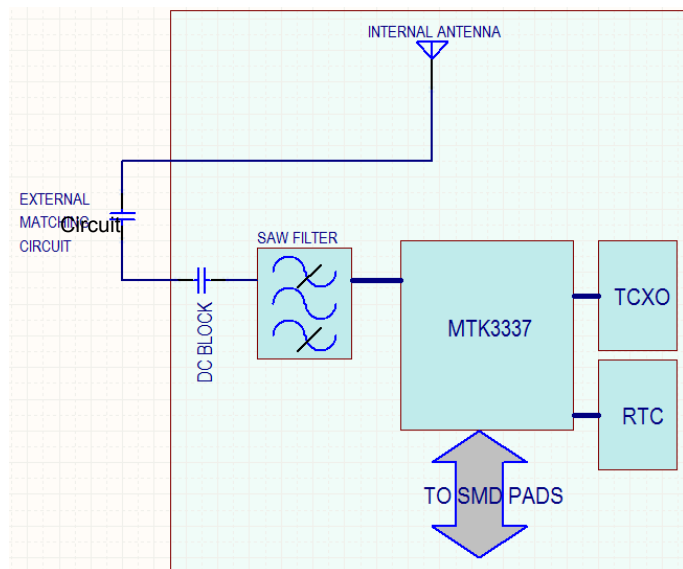

Description

Antenna M2M's GPS RADIONOVA® M10478-A2 antenna module is an ultra compact single package solution that combines full GPS receiver and antenna on the same module. The M10478-A2 is a highly integrated GPS RF antenna module suitable for L1-band GPS systems. The device is based on the Mediatek MT3337 GPS architecture combined with Antenna's antenna technology. Using patented external matching means this module is suitable from small watch applications to large tracker devices.

All front-end and receiver components are contained in a single package laminate base module, providing a complete GPS receiver for optimum performance. The M10478-A2 operates on a versatile 2.8V-4.2V supply with low power consumption and several low power modes for further power savings. An accurate 0.5ppm TXCO ensures short TTF. Indoor and outdoor multi-path detection and compensation. Support multi-GNSS incl. QZSS, SBAS ranging.

Providing a true drop in solution with the antenna and RF in a single SMT package, GPS RADIONOVA® M10478-A2 offers ease of integration and shorter design cycles for faster time to market.

Package Style

SMD Castellated pads enable SMT placement and re flow as well as hand soldering.
 13.8 x 9.5 x 1.8mm RF Antenna Module

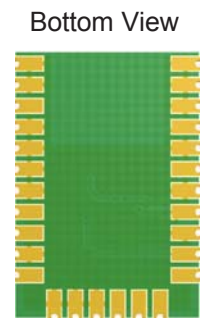
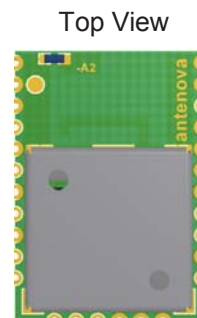

Absolute Maximum Ratings

Symbol	Parameter	Min	Max	Unit
V_{CC}	Main Supply Voltage	-0.3	4.3	V
V_{IO}	Supply voltage I/O ring	-0.3	3.6	V
V_{BATT}	VBACKP Supply	-0.3	4.3	V
RF_{IN}	Maximum RF Input Power	N/A	+10	dBm
T_{STG}	Storage Temperature	-40	+85	°C
T_A	Operating Temperature	-40	+85	°C

* Exposure to absolute ratings may adversely affect reliability and may cause permanent damage.

Recommended Operating Conditions

Symbol	Parameter	Min	Typ	Max	Unit
V_{CC}	Main Supply Voltage	2.8	3.3	4.3	V
V_{BATT}	VBACKP Supply	2.8	3.3	4.3	V
T_{OP}	Operating Temperature	-40	+85°C		

DC Electrical Characteristics

Conditions: $V_{CC} = 3.3V$, $T_{OP} = 25\text{ °C}$

Symbol	Parameter	Typ	Unit
$I_{CC(PK)}$	Peak Acquisition Current	31	mA
$I_{CC(AVG)}$	Average Tracking Supply Current	24	mA
$I_{CC(STBY)}$	Standby (Sleep) Power Supply Mode	<200	µA
$I_{CC(BCKUP)}$	Backup Mode	<200	µA

RF Specifications

Conditions: $V_{CC} = 3.3V$, $T_{OP} = 25\text{ °C}$, Freq = 1575.420MHz

Symbol	Parameter	Typ	Unit
NF_{LNA}	LNA Noise Figure	2	dB
ANT_{RL}	Antenna Return Loss	-15	dB
ANT_{BW}	Antenna Bandwidth at -10dB return loss	30	MHz
ANT_{EFF}	Antenna Total Efficiency	>40%	%
ANT_{EFF_RHCP}	Antenna RHCP Efficiency	>30%	%

Band Rejection*

Frequency	Standard	Typ*	Unit
698-798	LTE700	43	dB
824-849	Cellular CDMA	43	dB
869-894	GSM850	43	dB
880-915	GSM900	43	dB
1710-1785	GSM1800/DCS	44	dB
1850-1910	GSM1900/PCS	46	dB
1920-1980	WCDMA	46	dB
2400-2492	WLAN, BT and WiMAX	50	dB
2500-2690	LTE2600	52	dB

*Does not include antenna rejection.

Mechanical Specifications

Parameter	Typ	Unit
Module exterior dimensions (L x W x H)	13.8 (+0.1/-0.1) x 9.5 (+0.1 / -0.1) x 1.8 (+0.2 / - 0.0)	mm
Module support and connection	Surface mounted (SMD)	-
Module mass	<1	g

System Specifications

Communication	Specification
Data Output Protocol	NMEA 0183
Host Interfaces	UART
Default data rate on UART	4800/9600/38400/115200 bps
GPS Engine	
Chip	MTK MT3337 Chip
Channels	66 Acquisition Channels
TCXO	0.5ppm
Accuracy	
Horizontal Position Accuracy	<2.5m CEP
Maximum Position Update Rate	5 Hz
Sensitivity	
Acquisition (Cold)	-148dBm
Acquisition (Hot)	-163dBm
Tracking	-165dBm
TTFF	
Hot Start	<1s
Warm Start	<25s (typical)
Cold Start	<35s (typical)
General	
Maximum Altitude	<18.000 km
Maximum Speed	<514 m/s
Active Interference Cancellers	12 multi tone active cancellers ISSCC2011 award
Additional Features	SBAS, WAAS, EGNOS, QRZZ, GAGAN Support
EPO	Orbit prediction

50% CEP, Open-Sky, 24hr Static, -130dBm, good view of the sky

Pin out Description

Table shows the designation and function of each pin on the M10478-A2 module. Please note that several pins have multiple functions.

Pin	Designator	Description
1	GND	Ground connection
2	GND	Ground connection
3	GND	Ground connection
4	ANT_OUT	RF from internal antenna to external matching circuit
5	GND	Ground connection
6	ANT_IN	RF from external matching circuit back into module
7	GND	Ground connection
8	VCC	Main DC supply, +2.8 to +4.2V
9	GND	Ground connection
10	HRST	System reset, active low
	TM	1PPS Tim Mark Out
12	VBCKUP	Backup supply +2.0V to 4.2V
13	EINT2/GIO14	Hardware Baud rate select
14	EINT3/GIO15	Hardware Baud rate select
15	GND	Ground connection
16	GND	Ground connection
17	GND	Ground connection
18	FIXED INDICATOR	Indicates once a GPS fix has been obtained.
19	GND	Ground connection
20	TX	UART Transmit data line
21	RX	UART Receive data line
22	GND	Ground connection
23	GND	Ground connection
24	GND	Ground connection
25	GND	Ground connection
26	HW_STANDBY	Used to enable standby mode. If not used leave floating.
27	GND	Ground connection
28	GND	Ground connection

GPS RADIONOVA® RF Antenna Module
Part No. M10478-A2

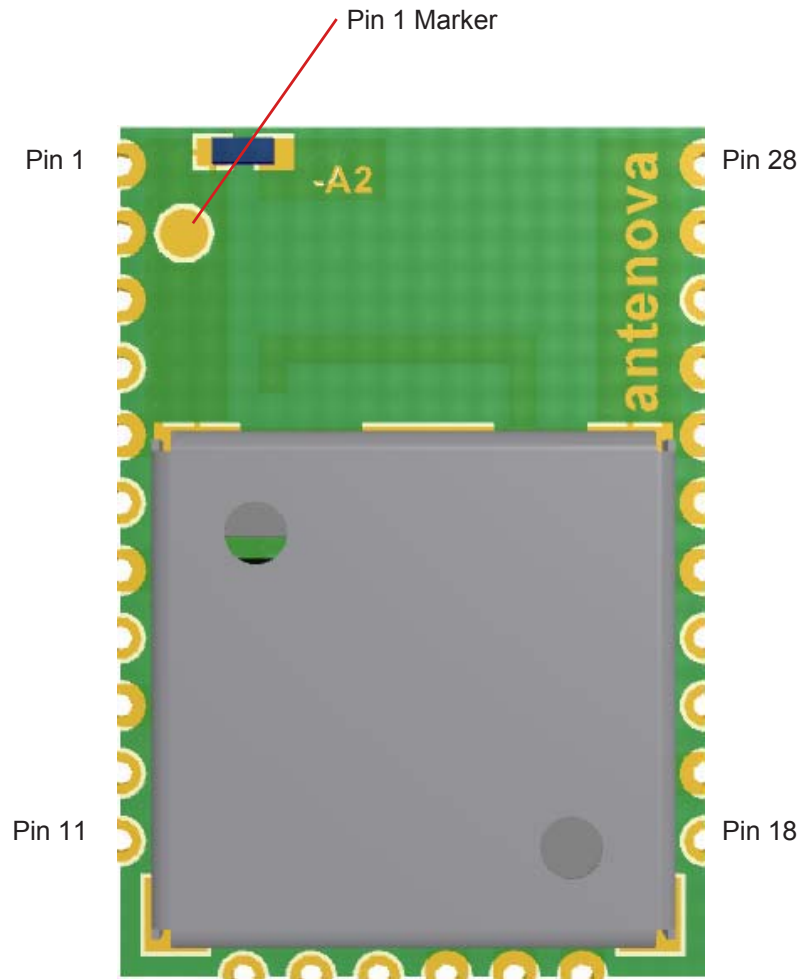

Application Schematic Example for M10478: UART - 9600 Baud

The circuit below shows a basic design for use with the UART interface and configuring the default baud rate to 9600.

Baud Rate = 9600 (Hardware configured)

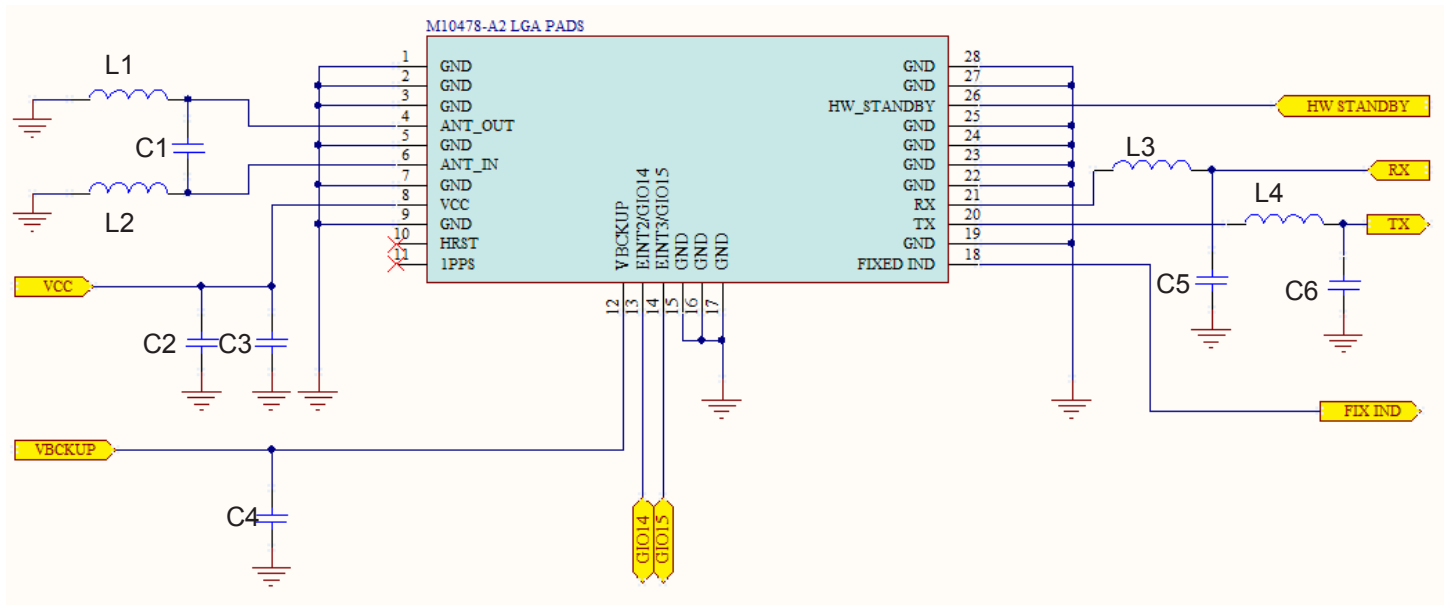

Bill of Material

Designator	Value	Description/Comments	Quantity
C1, L1, L2	TBD	Depending on device antenna matching circuit	TBD
C3, C4, C5, C6	22pF capacitor	Decoupling capacitor. Place close to corresponding pin	4
C2	2.2uF capacitor	Decoupling capacitor. Place close to corresponding pin	1
L3, L4	47nH Inductor	Filter component to suppress any potential host PCB noise	2

Host Baud Rate/Protocol Selection

The modules default baud rate is user configurable at start-up with a hardware configuration. This is limited to the values in the following table.

The baud rate and output protocol can be changed dynamically after start up using the relevant commands. Please contact Antenna for more information about protocol messages.

Hardware Baud Rate Selection Table

Baud Rate	Pin13 (GIO)	Pin 14 (GIO)
9600	NC	NC
115200	NC	PD
4800	PD	NC
38400	PD	PD

NC = Not connected. Leave floating
 PD = Pull down resistor to GND (10K Ω)

Host Interface Overview

UART Interface

The UART converts bytes of data to and from asynchronous start-stop bit streams as binary electrical impulses. The port contains a 16-byte FIFO, and 256 bytes of URAM. The bit rates are selectable from 4800, 9600, 38400 and 115200 bps.

The IO level from the UART port are CMOS compatible, however for RS-485 compatibility the use of external level shifters will be required. The hardware configuration of the port baud can be changed dynamically by the use of commands. These will be active and saved as long as the VBACKP supply is applied.

The default protocol is determined by hardware configuration.

Power Supply

The M10478-A2 uses two DC supply inputs. VBCKUP to power the RAM and RTC sections of the receiver, and VCC to power the digital and processing sections. VBCKUP is to be applied all the time to keep these sections alive. VCC can be removed to initiate a backup power save mode (See page 9). VBCKUP can be removed if a battery is also used at VBCKUP to maintain this supply. The supply is internally regulated for 2.8V meaning the external supply is versatile for a range of voltage levels.

TM (1PPS)

TM is a one pulse per second output from the receiver providing uses for timing purposes.

HRST (Hardware Reset Pin)

The External reset pin is default high by an internal 75Kohm and should be left floating if not used. To initiate a reset The pin needs to be pulled low. The module also initiates a reset if the VCC drops below the minimum 2.8V supply.

Power Management

The M10478-A2 has three power saving modes.

- Standby mode
- Back up mode
- Periodic mode

Standby Mode

Standby mode is a power saving mode that shuts down the RF section of the module and puts the processor into a standby mode. The RTC is kept alive and the RAM power is maintained to keep the module configuration. The standby state can be initiated either with a hardware signal to Pin26 or by using a command.

Hardware controlled Standby:

Enable standby mode by a low state to pin 26 (HW_STANDBY). To wake the module back to full power a high state Needs to be applied to pin 26. If Pin 26 is not to be used then it must be kept floating (not connected).

Standby mode command:

Software on the host needs to send the "PMTK161 command through the UART interface.

Command	M10478-A2 standby then wakeup	Current consumption (Typ)
\$PMTK161,0*28	M10478-A2 enters standby mode	<200uA
Any byte	M10478-A2 wakes up from standby mode	

Back up mode

To enter backup mode the VCC simply needs to be removed. Once initiated the RTC and all configuration is saved along with any ephemeris data to allow quick TTFF once the VCC is re-applied. VBACKUP needs to be applied at all times for backup mode to run correctly.

Periodic mode

Periodic mode is a module controlled mode that reduces current consumption by only waking the module for short periods to maintain fix data. The periodic state is user configured. Contact Antenna for more information and a user command manual.

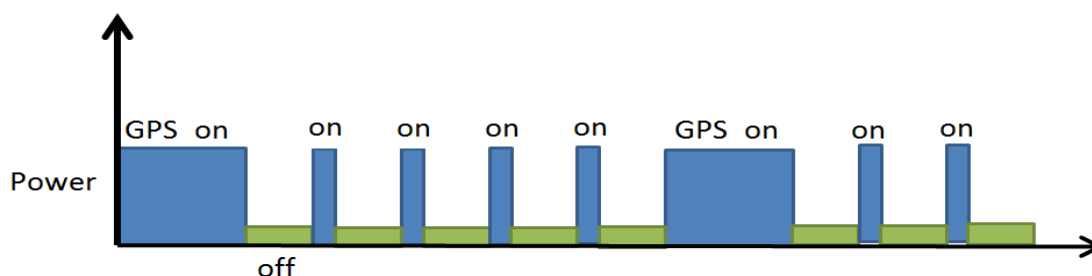

PMTK225 setting	M10478-A2 time off/awake	Current usage (Typ)
PMTK225, 2,3000,18000,72000	Module sleeps for 12secs, then wakes for 3secs periodically. 72000 is for a cold boot condition .	<200uA

EPO (Extended Prediction Orbit) data service

The EPO allows the use of up to a 30-day orbit predictions that can be used to aid the module for an instant fix solution

- A proxy server on the customers side to update EPO files from the MTK server daily.
- Application software to access the proxy server through the internet (optional if host device can access internet)
- Software on host device to send EPO data to M10478-A2 module to allow instant fix by using EE data.

Please contact Antenna for more information. Requires permission from MTK to use service.

AIC (Active Interference Cancellation)

The AIC feature provides effective narrow-band interference and jamming elimination. The GPS signal can be recovered from the jammed signal and allows users to obtain better navigation quality. This can be beneficial since many of today's devices have more and more functionality with regards to transmitters with many on-board antenna's

External Matching

The M10478-A2 module uses a matching circuit on the host PCB in order to fine-tune the on-board antenna to each specific application. This “external matching” allows compensating for the detuning of the antenna caused by various different components that can be close to the M10478-A2 module in the actual application (plastic case, battery, speakers etc).

The external matching must be placed on the host PCB between ANT_OUT (PIN3) and ANT_IN (PIN1). Although 2 components are typically more than enough to match the antenna to the 50Ω impedance required, a π -network topology with 3 components is recommended for safe proving.

Schematic

Both low-pass and hi-pass topologies for the matching network can be used with similar results. As the same footprint can be used for both topologies, the exact type and value of the components used can be determined during the optimization phase.

- The initial values can be simply chosen as the null-circuit (no impedance matching):
 - Hi-pass:
 - C1 = 18pF
 - L1, L2 = Not Fitted

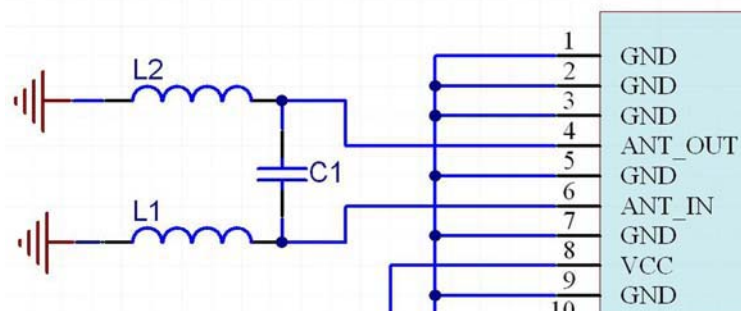

- Low-pass:
 - L1 = Jumper (0Ω resistor)
 - C1, C2 = Not Fitted

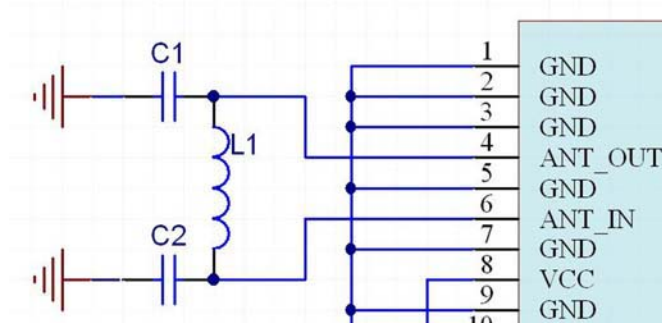

Type of Matching Components

- Capacitors:
 - Use 0402, COG components
- Inductors:
 - High-Q, wire wound inductors in 0402 size are recommended for maximum performance, e.g. Murata LQW15 series
 - Good quality multi-layer type inductors (e.g. Murata LQG15 series) can also be used as a lower cost alternative

Matching Procedure

The types and values of the matching components must be chosen so that the impedance seen by port ANT_IN (PIN4) is as close as possible as 50Ω. Although it is a relatively simple operation, it requires some RF skills and a VNA (Vector Network Analyzer). **Please contact an Antenova M2M FAE to get support on defining the optimal matching for your specific device.**

External Antenna Support

A low cost external circuit can be used to provide external antenna support. Please contact Antenova for more information, and example circuit.

PCB Matching Circuit Layout

The layout of the external matching circuit should be done using the following guidelines:

- Minimize the length of the tracks connecting the ANT_OUT and ANT_IN pads to the matching
- Minimize the length of the tracks between the components
- Use a solid groundplane under the matching circuit area
- Absolutely avoid routing any track under the matching circuit area
- Connect the top ground layer with the ground layer underneath using several vias

Layout drawings (Gerber or other format) are available from Antenova. Please contact your local FAE.

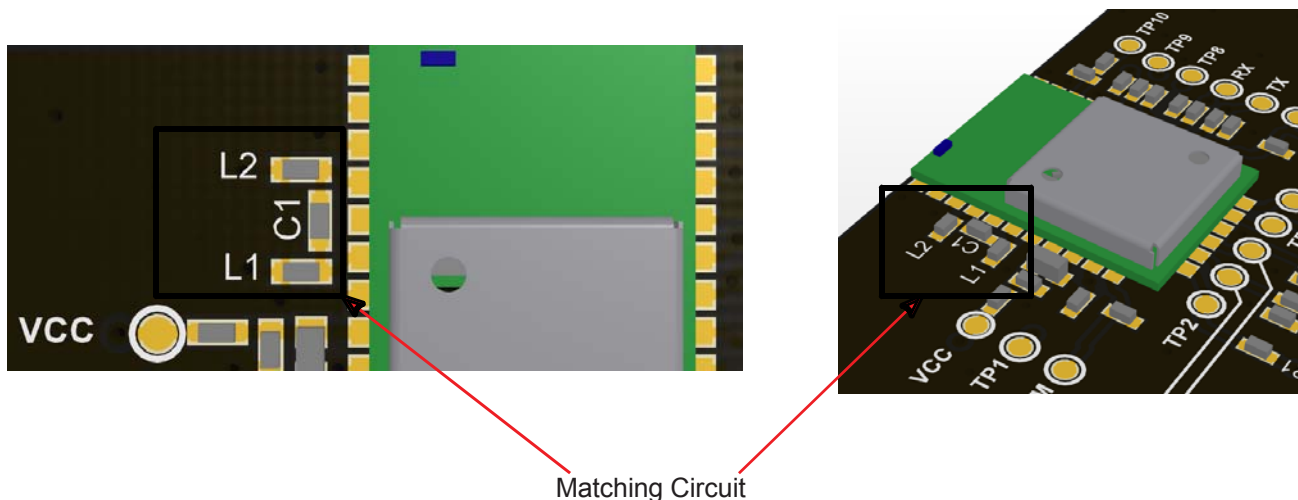

Example of external matching circuit layout

Internal Antenna Clearance

The M10478-A2 module internal antenna requires a small clearance on the host PCB to operate. The clearance means that no Ground or tracks of any kind are allowed to be within this area. This must also be clear through the entire PCB stack up. The minimum area needed clear is 6mm X 4.87mm.

Top view of M10478 Footprint

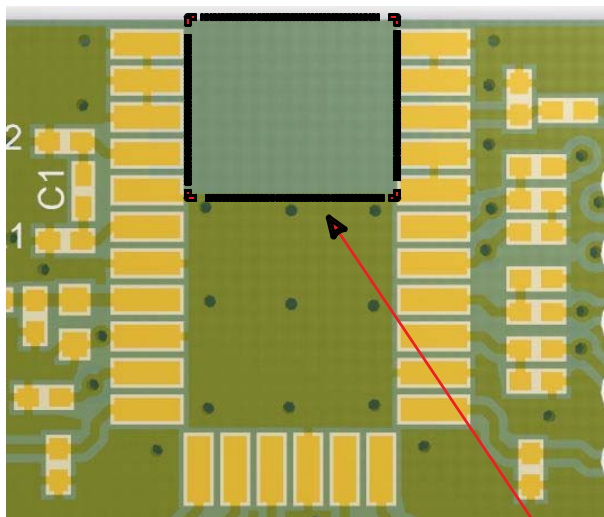

End view - 4 layer PCB stack-up

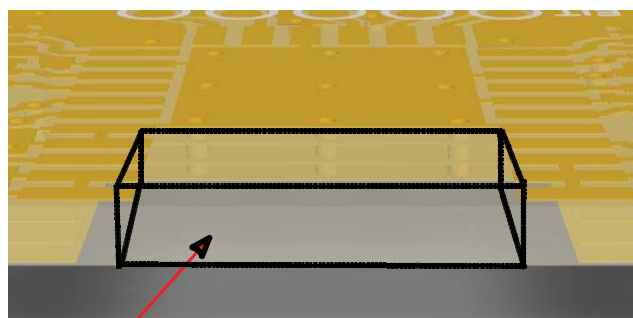

Keep out area

Typical RF Antenna Module Placement

Note: Module placement locations and orientations are critical for achieving optimal system performance. It is strongly recommended to contact Antenna M2M for design recommendations. Below is the placement shown on the Antenna evaluation PCB.

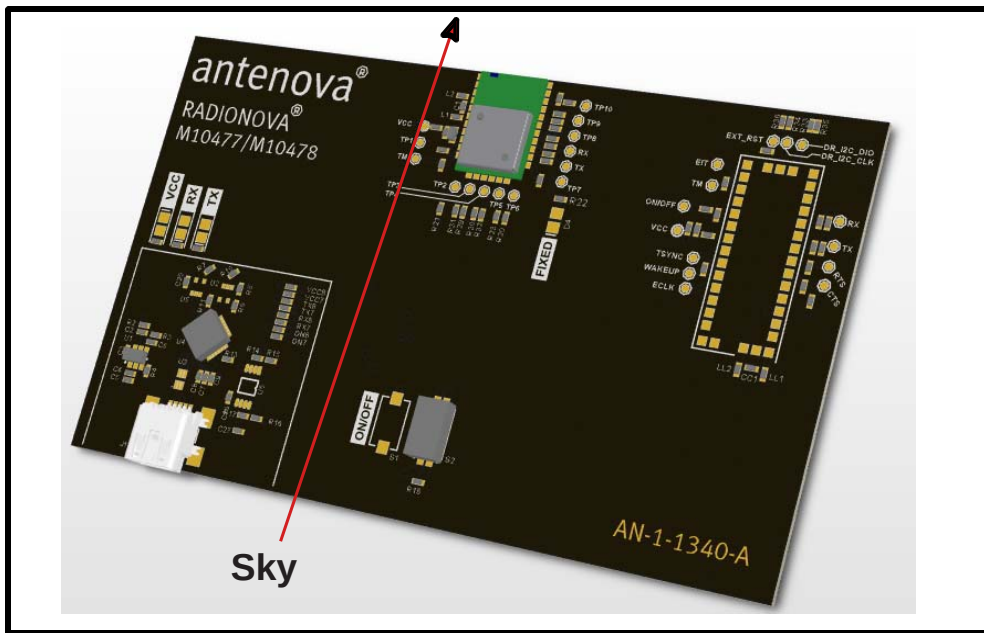

Front View



Back View

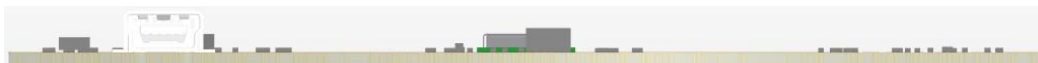

Side View

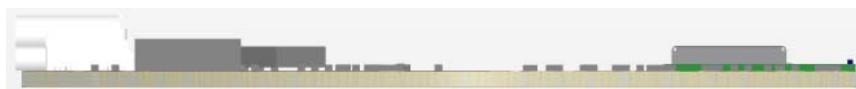

Typical Antenna Matching Results

Typical antenna matching as seen by ANT_IN (Pin 3) is shown in the following plot. The matching bandwidth at -10dB is typically 30MHz. Measured on M10478-U1 test board.

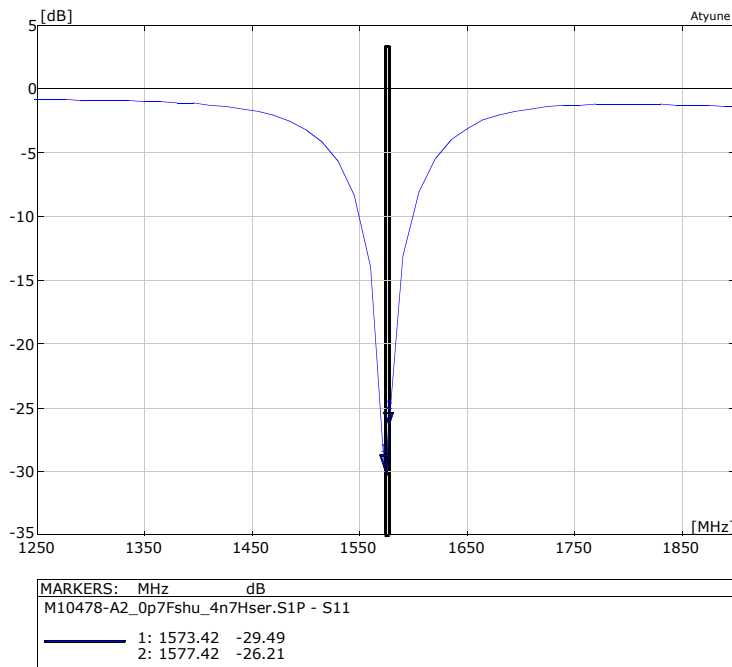

Typical antenna return loss after matching

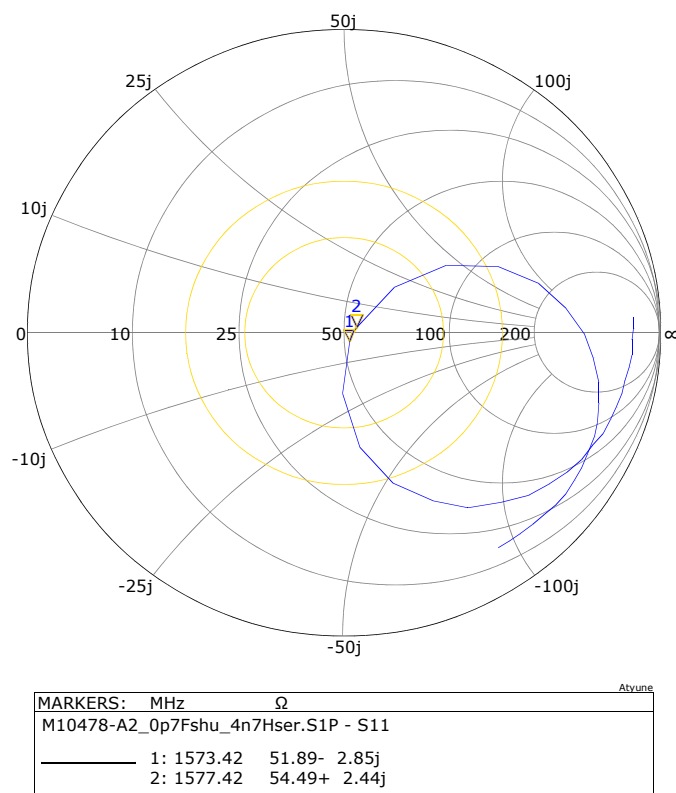

Front-end Rejection

The figure below shows the rejection for the input SAW filter before the RF input, including the effect of pads, tracks and decoupling. The plot can be useful to calculate the isolation required from adjacent transmitters in order to avoid the saturation of the LNA.

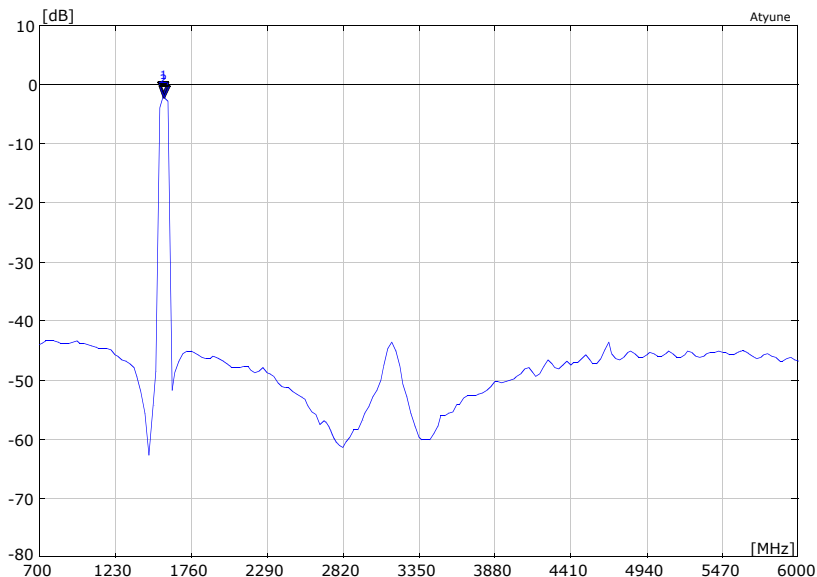

Input SAW Rejection - Wideband

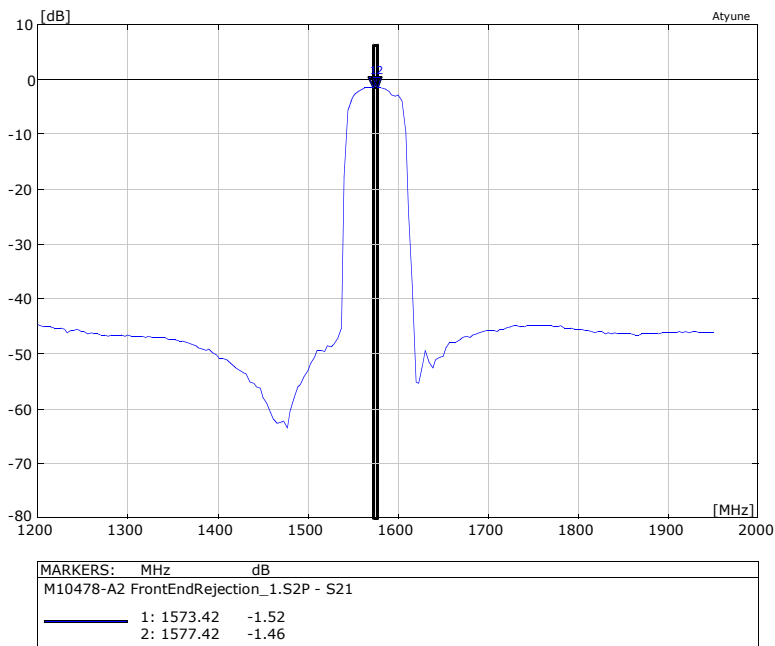

Input SAW Rejection - Narrowband

Module Placement Guidelines

Due to the internal antenna, care must be taken when defining the placement of the module on the host PCB. Here are some guidelines that should be used when deciding the position of the module.

- The module top edge must be placed almost level with the edge of the host PCB
- The edge of the host PCB that the module is to be placed at must be a minimum of 40mm in length.

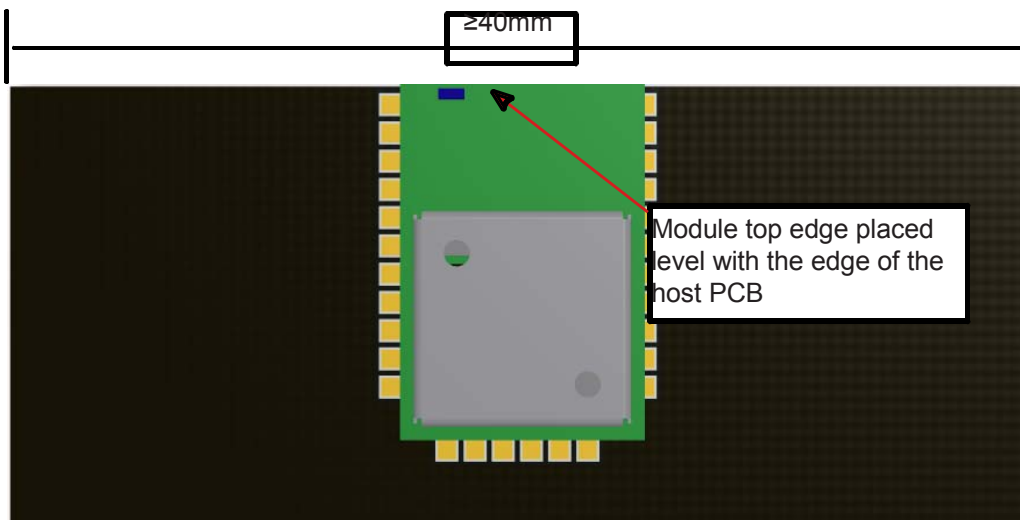

- The central placement of the module is advised. However, an offset placement is also possible.
- For an offset closer to the PCB edge to the right side of the module, a minimum of 10mm distance is required to the edge of the host PCB.

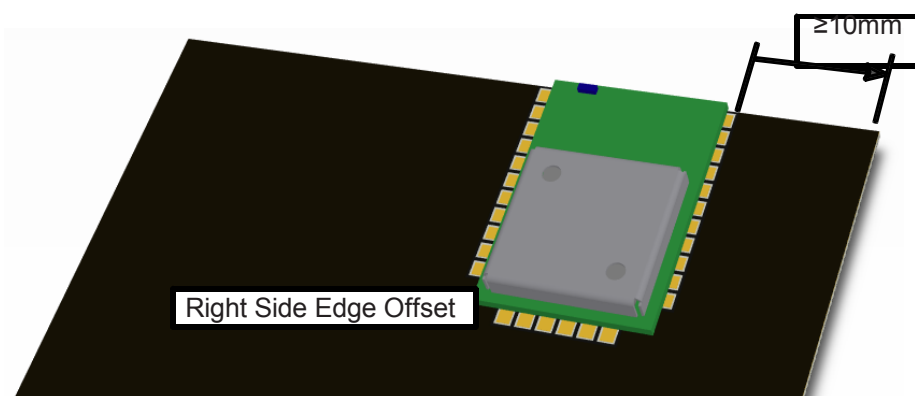

- For an offset closer to the PCB edge on the left side of the module, a minimum of 15mm distance is required to the edge of the host PCB. This additional distance is due to the matching circuit placement.

GPS RADIONOVA® RF Antenna Module
 Part No. M10478-A2

- For an offset closer to the PCB edge to the left side of the module, a minimum of 15mm distance is required to the edge of the host PCB. This additional distance is due to the matching circuit placement.

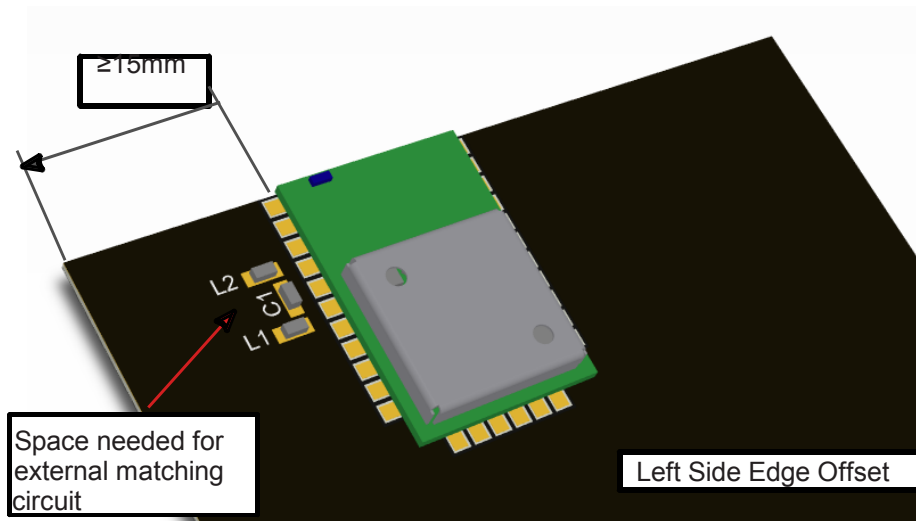

- The antenna uses the host PCB ground to effectively radiate. As such, a GND plane must be placed on the host PCB on at least one layer.
- In the example below, the only area void of GND is the antenna keep-out area.

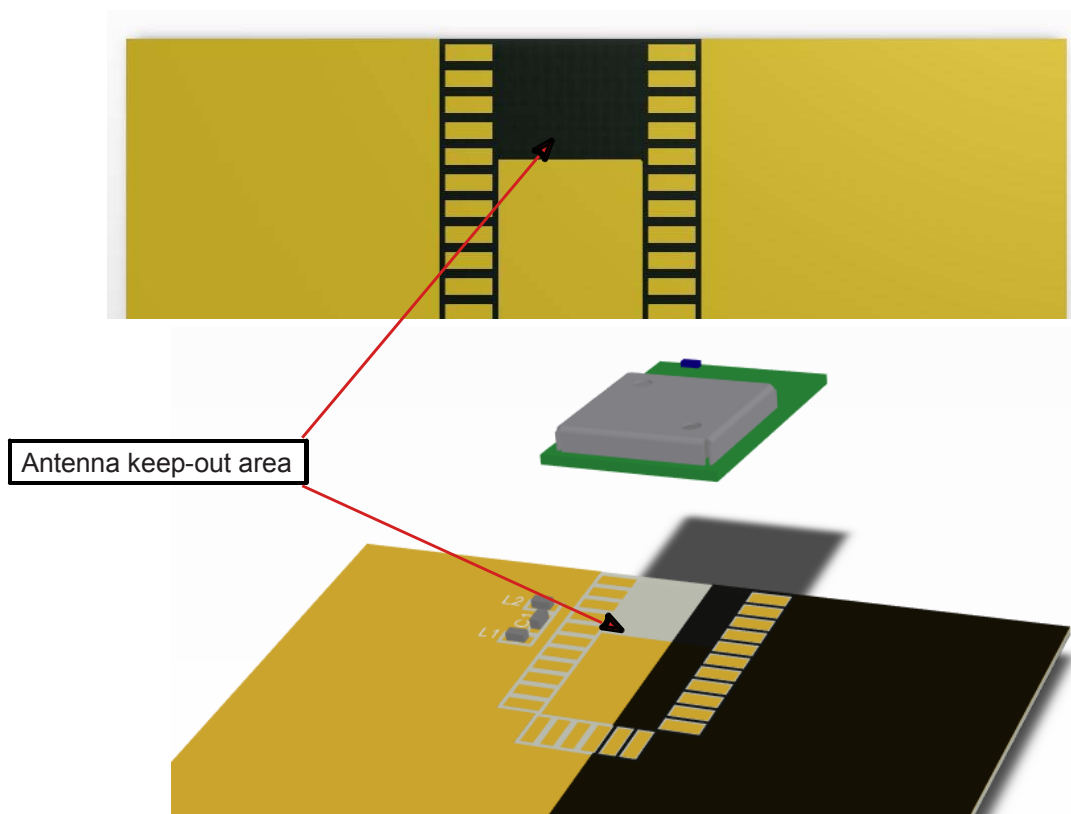

GPS RADIONOVA® RF Antenna Module
 Part No. M10478-A2

- An ideal stack-up for a host PCB would be to use the top and bottom layers as GND planes, while using the internal layers for any signal and power planes. This not only helps the GPS antenna to perform effectively, but also helps to reduce any potential noise issues that can be associated with mixed signal PCB's.
- An exaggerated example below shows a 4 layer host PCB, GND flooding all available space not used by signals or components.

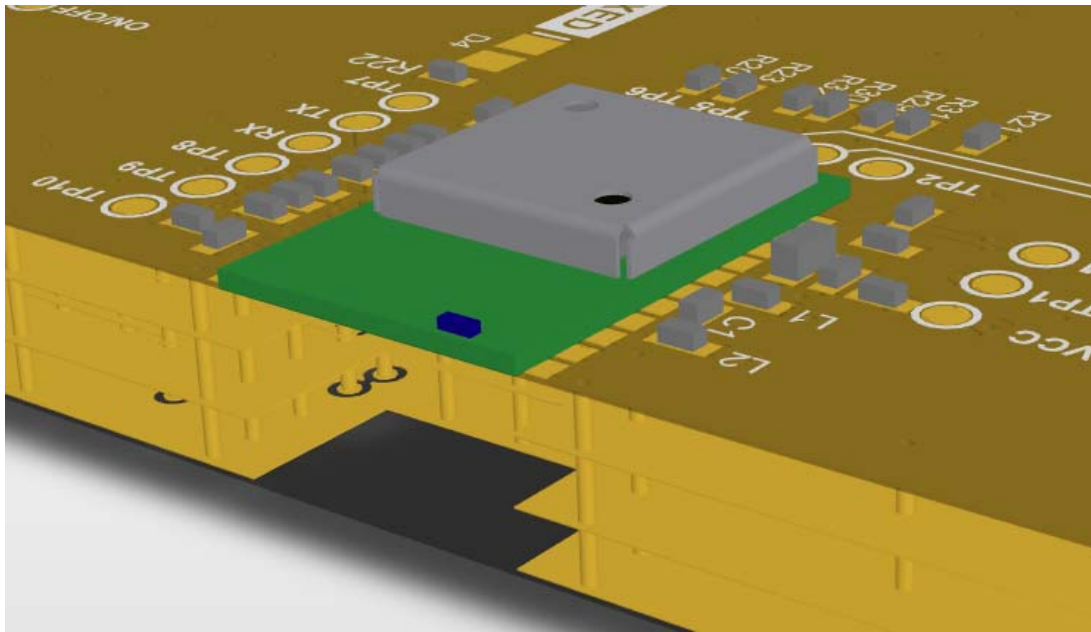

Please contact Antenna M2M for advice on placement.

Reflow Soldering

Placement

Typical placement systems used for any BGA/LGA package are acceptable. Recommended nozzle diameter for placement: 5mm

Soldering Paste

Use of "No Clean" soldering paste is strongly recommended, as it does not require cleaning after the soldering process has taken place. An example of suitable soldering paste is Alpha OM350.

Soldering

The recommended soldering profile for M10478-A2 is shown below. However, it is the responsibility of the Contract Manufacturer to determine the exact reflow profile used, taking into consideration the parameters of the host PCB, solder paste used, etc.

Profile Feature		Pb-Free Solder
Pre-Heat	Temperature (T_s) Min	130°C
	Temperature (T_s) Max	220°C
	Time (t_s)	<150s
Reflow	Liquidus Temperature - (T_l)	220°C
	Time (t_l)	45-90s
Peak Package Body Temperature (T_p)		245°C
Time within 5°C of peak temp (t_p)		30s
Average Ramp up rate - $T_s(\text{max})$ to (T_p)		3°C/s
Ramp Down Rate		6°C/s max

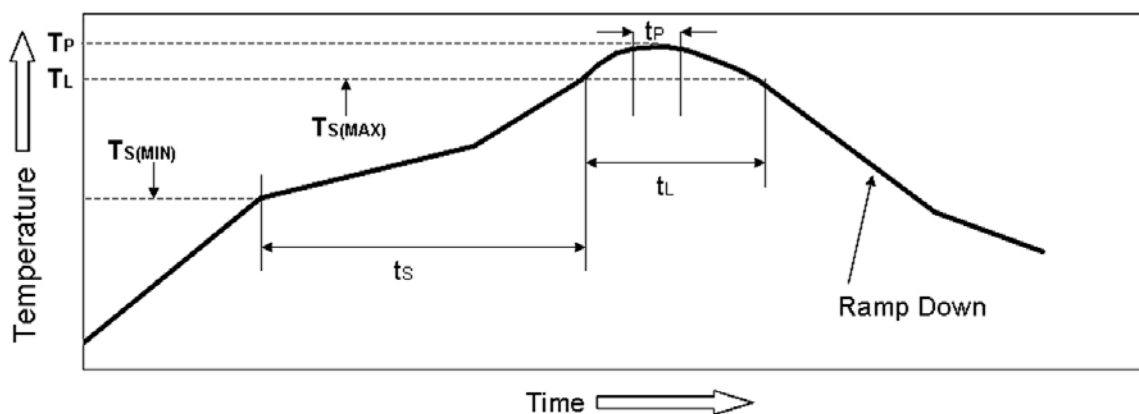

Example Reflow profile

The Pb Free Process-Package Peak Reflow Temperature is 260°C.

Exceeding the maximum soldering temperature could permanently damage the module.

GPS RADIONOVA® RF Antenna Module

Part No. M10478

Multiple Soldering

The M10478-A2 module can be submitted up to 2 reflow soldering processes.

Upside-down soldering is acceptable but it is recommended that the Contract Manufacturer qualify the process before mass production. The second reflow must take place within the recommended floor life limit (MSL3). Please contact Antenova for further information.

Hand Soldering

Hand-soldering and rework of the M10478-A2 module is acceptable, however care must be taken to avoid short circuits due to the small size of the module pads.

Quality and Environmental Specifications

Test	Standard	Parameters
PCB Inspection	IPC-6012B, Class 2. Qualification and Performance Specification for Rigid Printed Boards - Jan 2007	
Assembly Inspection	IPC-A-610-D, Class 2 "Acceptability of electronic assemblies"	
Temperature Range	ETSI EN 300 019-2-7 specification T 7.3	-30 °C, +25 °C, +85 °C, operating
Damp Heat	ETSI EN 300 019-2-7 specification T 7.3	+70 °C, 80% RH, 96 hrs, non-operating
Thermal Shock	ETSI EN 300 019-2-7 specification T 7.3 E	-40 °C ... +85 °C, 200 cycles
Vibration	ISO16750-3	Random vibration, 10~1000Hz, 27.8m/s ² , 8hrs/axis, X, Y, Z 8hrs for each 3 axis non-operating
Shock	ISO16750-3	Half-sinusoidal 50g, 6ms, 10time/face, ±X, ±Y and ±Z non-operating
Free Fall	ISO16750-3	1m height, 2 drops on opposite side
ESD Sensitivity	JEDEC, JESD22-A114 ESD Sensitivity Testing Human Body Model (HBM), Class 2 JEDEC, JESD22-A115 ESD Sensitivity Testing Machine Model (MM), Class B	+2000V - Human hand assembly +200V - Machine automatic final assembly
Shear	IEC 60068-2-21, Test Ue3: Shear	Force of 5N applied to the side of the PCB
Moisture/Reflow Sensitivity	IPC/JEDEC J-STD-020D.1	MSL3
Storage (Dry Pack)	IPC/JEDEC J-STD-033C	MSL3
Solderability	EN/IEC 60068-2-58 Test Td	More than 90% of the electrode should be covered by solder. Solder temperature 245 °C ± 5 °C

Moisture Sensitivity

Antenna ships all devices dry packed in tape on reel with desiccant and moisture level indicator sealed in an airtight package. If on receiving the goods the moisture indicator is pink in color or a puncture of the airtight seal packaging is observed, then follow J-STD-033 "Handling and Use of Moisture/Reflow Sensitive Surface Mount Devices".

Storage (Out of Bag)

The M10478-A2 modules meet MSL Level 3 of the JEDEC specification J-STD-020D - 168 hours Floor Life (out of bag) ≤30 °C/60% RH. If the stated floor life expires prior to reflow process then follow J-STD-033 "Handling and Use of Moisture/Reflow Sensitive Surface Mount Devices".

Hazardous material regulation conformance

The RF antenna module meets RoHS requirements.

Packaging

Tape Characteristics

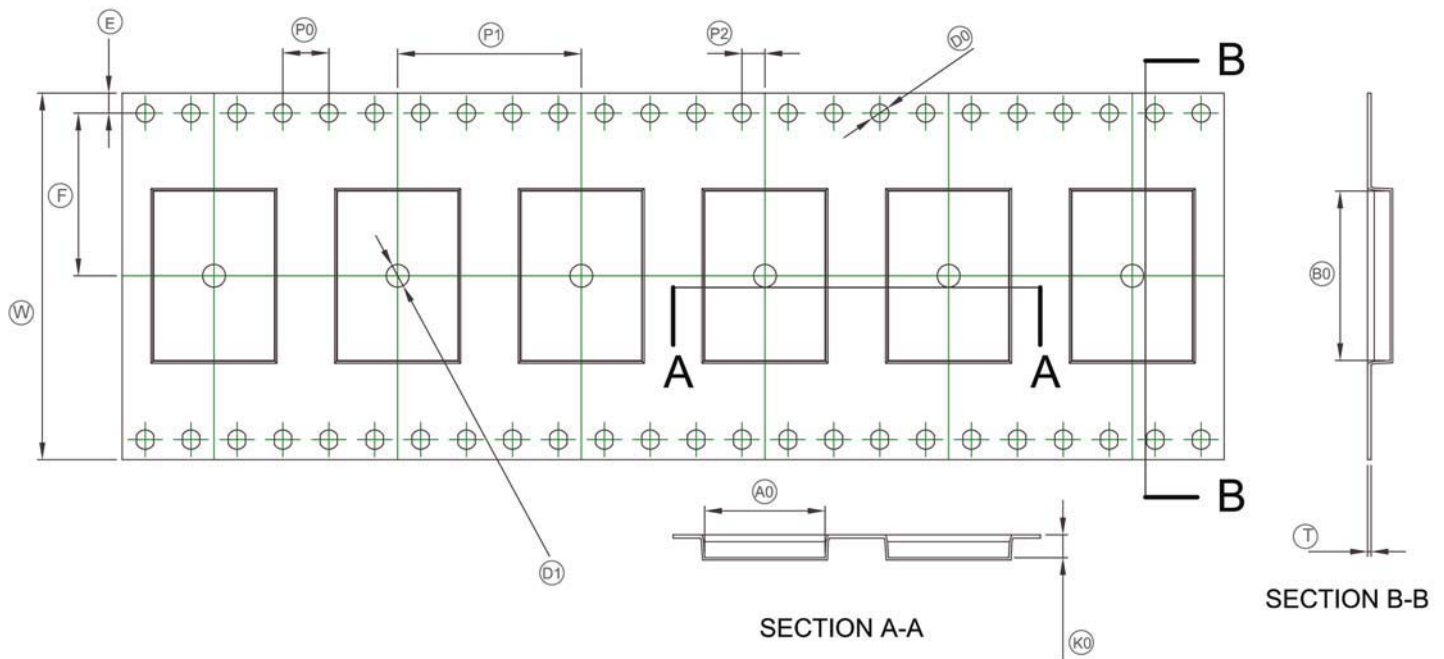

WFEP0P1P2					
32.00±0.3	14.20±0.1	1.75±0.2	4.00±0.1	16±0.1	2.00±0.1
D0	B0	T	K0	A0	D1
1.55±0.1	14.80±0.1	0.30±0.1	2.00±0.1	10.50±0.05	0.85±0.1

Dimensions in mm

Quantity	Leading Space	Trailing Space
1000 pcs / reel	50 blank module holders	50 blank module holders

Reel Dimensions

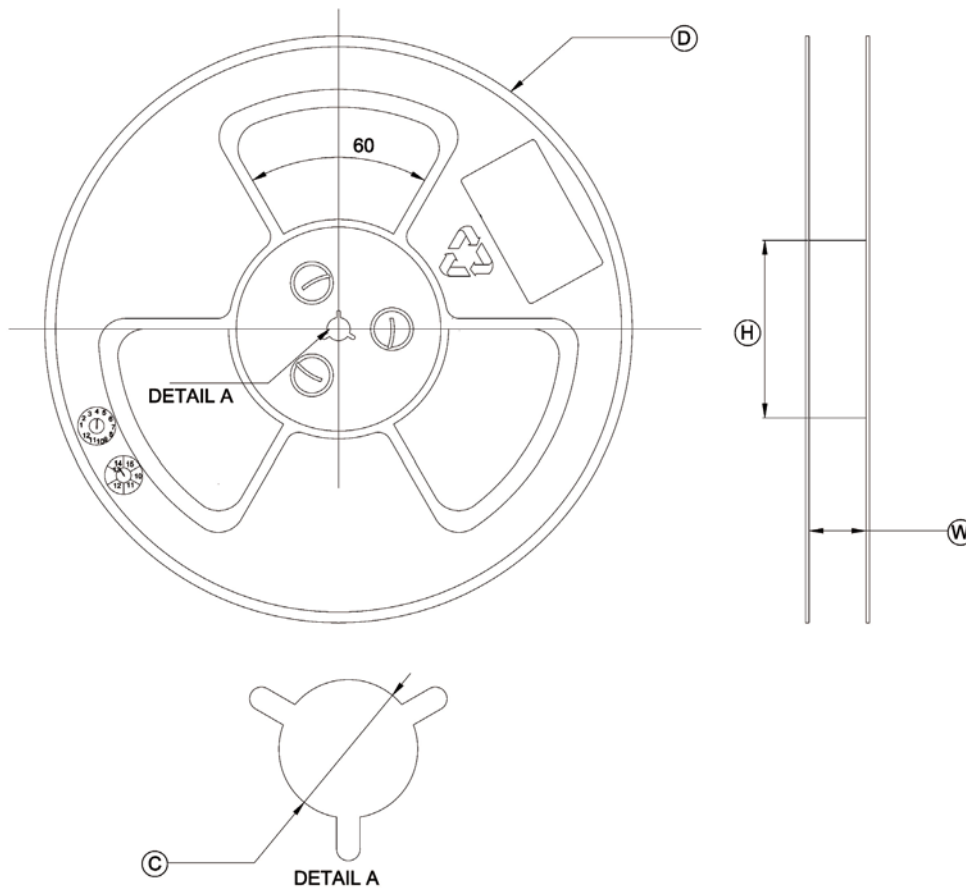

Width (W)	Reel Diameter (D)	Hub Diameter (H)	Shaft Diameter (C)
32.0mm	330.0±2mm	100.0mm	13.0+0.2/-0.0mm



www.antenova-m2m.com

Corporate Headquarters

Antenova Ltd.
Far Field House
Albert Road
Stow-cum-Quy
Cambridge, CB25 9AR
UK

Tel: +44 (0) 1223 810600
Fax: +44 (0) 1223 810650
Email: sales@antenova-m2m.com

USA Headquarters

Antenova USA
Rogers Business Park
2541 Technology Drive, Suite 403
Elgin, IL 60124
USA

Tel: +1 (847) 551-9710
Fax: +1 (847) 551-9719
Email: sales@antenova-m2m.com

Asia Headquarters

Antenova Asia Ltd.
4F, No. 324, Sec. 1, Nei-Hu Road
Nei-Hu District
Taipei 11493
Taiwan, ROC

Tel: +886 (0) 2 8797 8630
Fax: +886 (0) 2 8797 6890
Email: sales@antenova-m2m.com

Copyright® 2013 Antenova Ltd. All Rights Reserved. Antenova®, Antenova M2M, RADIONOVA® and the Antenova and Antenova M2M logos are trademarks and/or registered trademarks of Antenova Ltd. Any other names and/or trademarks belong to their respective companies.

The materials provided herein are believed to be reliable and correct at the time of print. Antenova does not warrant the accuracy or completeness of the information, text, graphics or other items contained within these information. Antenova further assumes no responsibility for the use of this information, and all such information shall be entirely at the user's risk.



Certificate No: 4598

Antennas for Wireless M2M Applications

27

Product Specification 12MD-0050-2-PS

Release Date 05 February 2013

Description of differences between beacon model variants
