



FCC CFR 47 Part 22 E Test Report

| | |
|-----------------------------|---|
| APPLICANT | STANDARD COMMUNICATIONS PTY.LTD. |
| ADDRESS | 17 GIBBON ROAD WINSTON HILLS NSW 2153 AUSTRALIA |
| FCC ID | TXJCM60UL25 |
| MODEL NUMBER | CM60-UL25B, CM60-UL25D, CM60-UL25L, CM60-UL25P, CM60-UL25R, CM60-UL25S |
| PRODUCT DESCRIPTION | UHF MOBILE TRANSCEIVER |
| DATE SAMPLE RECEIVED | 4/11/2018 |
| FINAL TEST DATE | 4/27/2018 |
| TESTED BY | Franklin Rose |
| APPROVED BY | Tim Royer |
| TEST RESULTS | <input checked="" type="checkbox"/> PASS <input type="checkbox"/> FAIL |

| Report Number | Report Version | Description | Issue Date |
|------------------------------|----------------|--|------------|
| 484CUT18 PT22_TestReport_ | Rev1 | Initial Issue | 04/27/2018 |
| 484CUT18 PT22_TestReport_ | Rev2 | Clerical Updates | 05/30/2018 |
| 484CUT18 PT22_TestReport_ | Rev3 | Updated Model Numbers and Emission Designator | 11/06/2018 |
| 484CUT18 PT22_TestReport_ | Rev4 | Updated Address | 12/28/2018 |

THE ATTACHED REPORT SHALL NOT BE REPRODUCED EXCEPT IN FULL WITHOUT THE WRITTEN APPROVAL OF TIMCO ENGINEERING, INC.

TABLE OF CONTENTS

| | |
|--|-----------|
| GENERAL REMARKS | 2 |
| GENERAL INFORMATION | 3 |
| RESULTS SUMMARY | 4 |
| RF POWER OUTPUT | 5 |
| PART 2.1033 (c)(8) DC INPUT INTO FINAL AMPLIFIER..... | 5 |
| MODULATION CHARACTERISTICS | 6 |
| 11K2F3E (NARROWBAND ANALOG FM VOICE) BANDWIDTH | 6 |
| 8K10F1E/F1D (C4FM VOICE/DATA) BANDWIDTH | 6 |
| AUDIO FREQUENCY RESPONSE & LOW PASS FILTER | 7 |
| <i>Test Data: 12.5 kHz FM Audio Frequency Response & Low Pass Filter</i> | 7 |
| MODULATION LIMITING | 8 |
| <i>Test Data: 12.5 kHz FM Modulation Limiting</i> | 8 |
| OCCUPIED BANDWIDTH | 9 |
| TEST DATA: 11K2F3E (NARROWBAND ANALOG FM VOICE)..... | 10 |
| TEST DATA: 8K10F1E/F1D (C4FM VOICE/DATA) | 11 |
| SPURIOUS EMISSIONS AT ANTENNA TERMINALS (CONDUCTED) | 12 |
| SPURIOUS EMISSIONS - NARROWBAND FM (12.5 kHz) | 13 |
| <i>Test Data: 454.00625 MHz</i> | 13 |
| <i>Test Data: 454.99375 MHz</i> | 14 |
| <i>Test Data: 456.00625 MHz</i> | 15 |
| <i>Test Data: 459.99375 MHz</i> | 16 |
| <i>Test Data: 470.00625 MHz</i> | 17 |
| <i>Test Data: 475.0000 MHz</i> | 18 |
| <i>Test Data: 479.99375 MHz</i> | 19 |
| SPURIOUS EMISSIONS – P25 PHASE I C4FM | 20 |
| <i>Test Data: 454.00625 MHz</i> | 20 |
| <i>Test Data: 454.99375 MHz</i> | 21 |
| <i>Test Data: 456.00625 MHz</i> | 22 |
| <i>Test Data: 459.99375 MHz</i> | 23 |
| <i>Test Data: 470.00625 MHz</i> | 24 |
| <i>Test Data: 475.0000 MHz</i> | 25 |
| <i>Test Data: 479.99375 MHz</i> | 26 |
| FIELD STRENGTH OF SPURIOUS EMISSIONS | 27 |
| TEST DATA: 454.00625 MHz | 28 |
| TEST DATA: 454.99375 MHz | 30 |
| TEST DATA: 456.00625 MHz | 33 |
| TEST DATA: 459.99375 MHz | 36 |
| TEST DATA: 470.00625 MHz | 39 |
| TEST DATA: 475.00 MHz..... | 40 |
| TEST DATA: 479.99375 MHz | 41 |
| FREQUENCY STABILITY | 43 |
| STATEMENT OF MEASUREMENT UNCERTAINTY | 46 |
| EMC EQUIPMENT LIST | 47 |

GENERAL REMARKS

Summary

The device under test does:

- Fulfill the general approval requirements as identified in this test report and was selected by the customer.
- Not fulfill the general approval requirements as identified in this test report

Attestations

This equipment has been tested in accordance with the standards identified in this test report. To the best of my knowledge and belief, these tests were performed using the measurement procedures described in this report.

All instrumentation and accessories used to test products for compliance to the indicated standards are calibrated regularly in accordance with ISO 17025 requirements.

I attest that the necessary measurements were made at:

Timco Engineering Inc.
849 NW State Road 45
Newberry, FL 32669
Designation #: US1070

Tested by:



| | |
|-----------------------|---|
| Name and Title | Franklin Rose, Project Manager / EMC Testing Technician |
| Date | 04/27/2018 |

Reviewed and Approved by:



| | |
|-----------------------|---|
| Name and Title | Tim Royer, Project Manager / EMC Testing Engineer |
| Date | 04/27/2018 |

GENERAL INFORMATION

EUT Specification

| | |
|--------------------------------|--|
| EUT Description | UHF MOBILE TRANSCEIVER |
| FCC ID | TXJCM60UL25 |
| Model Number | CM60-UL25B, CM60-UL25D, CM60-UL25L, CM60-UL25P, CM60-UL25R, CM60-UL25S |
| Operating Frequency | Band 1: 454 – 455 MHz Band 2: 456 – 460 MHz Band 3: 470 - 480 MHz |
| Test Frequencies | Band 1: 454.00625, 454.99375 MHz Band 2: 456.00625, 459.99375 MHz Band 3: 470.00625, 475.00, 479.99375 MHz |
| Type of Emission | 11K2F3E (Narrowband Analog FM Voice), 8K10F1E (P25 Phase I C4FM Voice), 8K10F1D (P25 Phase I C4FM Data) |
| Modulation | FM |
| EUT Power Source | <input type="checkbox"/> 110–120Vac/50– 60Hz |
| | <input checked="" type="checkbox"/> DC Power (13.8 V) |
| | <input type="checkbox"/> Battery Operated Exclusively |
| Test Item | <input type="checkbox"/> Prototype |
| | <input checked="" type="checkbox"/> Pre-Production |
| | <input type="checkbox"/> Production |
| Type of Equipment | <input type="checkbox"/> Fixed |
| | <input checked="" type="checkbox"/> Mobile |
| | <input type="checkbox"/> Portable |
| Antenna Connector | BNC |
| Test Conditions | The temperature was 26°C Relative humidity of 50%. |
| Modification to the EUT | No Modification to EUT. |
| Test Exercise | The EUT was placed in continuous transmit and was operated in “Test Mode” for digital emissions tests. |
| Applicable Standards | ANSI/TIA 603-E:2016, ANSI C63.26, FCC CFR 47 Part 2, Part 22 |
| Test Facility | Timco Engineering Inc. at 849 NW State Road 45 Newberry, FL 32669 USA. Designation #: US1070 |

RESULTS SUMMARY

| Rule Part No. | Test Item | Results |
|--|---|-------------|
| 2.1046(a), 22.565(f), 22.593, 22.627(a), (b), 22.659(a) | RF Power Output | PASS |
| Part 2.1033(c)(4), Part 22.357 | Modulation Characteristics | PASS |
| 2.1047(a) | Audio Frequency Response and Low Filter | PASS |
| 2.1047(b) | Modulation Limiting | PASS |
| 2.1049 (c) | Occupied Bandwidth | PASS |
| 2.1051(a), 22.359(a) | Spurious Emissions at Antenna Terminals | PASS |
| 2.1053(a), 22.359(a) | Field Strength of Spurious Emissions | PASS |
| 2.1055(a)(2), 22.355 | Frequency Stability < 5 ppm | PASS |

RF POWER OUTPUT

FCC Rule Parts: 2.1046(a), 22.565(f), 22.593, 22.627(a), (b), 22.659(a)

(f) *Mobile transmitters.* The transmitter output power of mobile transmitters must not exceed 60 watts.

The effective radiated power of fixed stations operating on the channels listed in §22.591 must not exceed 150 Watts. The equivalent isotropically radiated power of existing fixed microwave stations (2110-2130 and 2160-2180 MHz) licensed under this part (pursuant to former rules) must not exceed the applicable limits set forth in §101.113 of this chapter.

The effective radiated power (ERP) of transmitters operating on the channels listed in §22.621 must not exceed the limits in this section.

(a) *Maximum ERP.* The ERP must not exceed the applicable limits in this paragraph under any circumstances.

| Frequency range (MHz) | Maximum ERP (watts) |
|-----------------------|---------------------|
| 470-512 | 1000 |
| 928-929 | 50 |
| 932-933 | 30 |
| 941-942 | 600 |
| 952-960 | 150 |

(b) *470-512 MHz limits.* The purpose of the rules in paragraphs (b)(1) through (b)(3) of this section is to reduce the likelihood that interference to television reception from public mobile operations on these channels will occur. The protected TV station locations specified in this section are the locations of record as of September 1974, and these do not change even though the TV stations may have been subsequently relocated.

(a) *Maximum ERP.* The ERP of base transmitters must not exceed 100 Watts under any circumstances. The ERP of mobile transmitters must not exceed 60 Watts under any circumstances.

Method of Measurement: TIA-603-E, 2.2.1

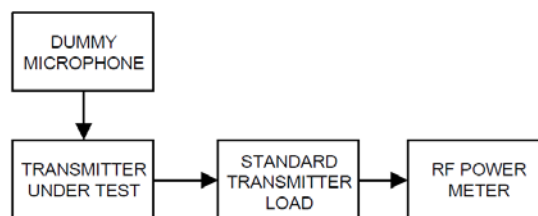

Test Data: Power Measurement Table

| Peak Power Output | | | | | |
|-------------------|-------|-------|-------|-------|------|
| dBm | | | Watts | | |
| High | Med | Low | High | Med | Low |
| 44.00 | 40.16 | 30.17 | 25.12 | 10.38 | 1.04 |

Part 2.1033 (c) (8) DC Input into Final Amplifier

INPUT POWER: (13.8 V) (6.0 A) = **82.8 Watts**

Result: Meets Requirements

Applicant: STANDARD COMMUNICATIONS PTY.LTD.
 FCC ID: TXJCM60UL25
 Report: 484CUT18 PT22_TestReport_Rev4

[Table of Contents](#)

MODULATION CHARACTERISTICS

FCC Rule Parts: Part 2.1033(c)(4), Part 22.357

§22.357 Emission types.

Any authorized station in the Public Mobile Services may transmit emissions of any type(s) that comply with the applicable emission rule, *i.e.* §22.359, §22.861 or §22.917.

11K2F3E (Narrowband Analog FM Voice) Bandwidth

$$B_n = 2M + 2Dk$$
$$B_n = (2*3) + (2*2.5) = 11.0 \text{ kHz}$$

Where:

$$f_m = \text{modulating frequency, kHz}$$
$$f_d = \text{deviation, kHz}$$
$$k = \text{constant} (= 1)$$

Necessary Bandwidth for 11K2F3E = **11.0 kHz**

90. 209(b)(5) Authorized Bandwidth for 11K2F3E = **11.25 kHz**

8K10F1E/F1D (C4FM Voice/Data) Bandwidth

$$B_n = (R/\log_2 S) + 2DK$$
$$B_n = (9600/\log_2(4)) + 2(1800)(0.916)$$
$$B_n = 4800 + 3298$$
$$B_n = 8.10 \text{ kHz}$$

Where:

$$R \text{ (data rate)} = 9600 \text{ bps}$$
$$D \text{ (peak deviation)} = 1800 \text{ Hz}$$
$$S \text{ (symbols)} = 4$$
$$K \text{ (constant)} = 0.916$$

Necessary Bandwidth for 8K10F1E/F1D = **8.10 kHz**

90. 209(b)(5) Authorized Bandwidth for 8K10F1E/F1D = **11.25 kHz**

Note: This device is intended for operation also under FCC CFR 47 Part 90. Part 22 E "One-way or Two-way Mobile Operation" does not provide a bandwidth limitation, so Part 90 bandwidth limitations have been shown in this test report.

Result: Meets Requirements

AUDIO FREQUENCY RESPONSE & LOW PASS FILTER

Rule Part No.: 2.1047(a)

Requirements:

(a) *Voice modulated communication equipment.* A curve or equivalent data showing the frequency response of the audio modulating circuit over a range of 100 to 5000 Hz shall be submitted. For equipment required to have an audio low-pass filter, a curve showing the frequency response of the filter, or of all circuitry installed between the modulation limiter and the modulated stage shall be submitted.

Test Procedure: TIA 603-E, 2.2.6.2.2, 2.2.15 (Using the Test Setup from section 2.2.6)

Note: The Low Pass Filter is digital, and has no "input" or "output" as found in the method of measurement, above. Testing has been altered accordingly to show the operation of the filter.

Note: Testing deviates from TIA 603-E 2.2.6.2.2 and 2.2.15. The Audio Frequency Response and Low Pass Filter Response plot data has been taken simultaneously using the Modulation Meter reading of Deviation (kHz), satisfying the requirements above.

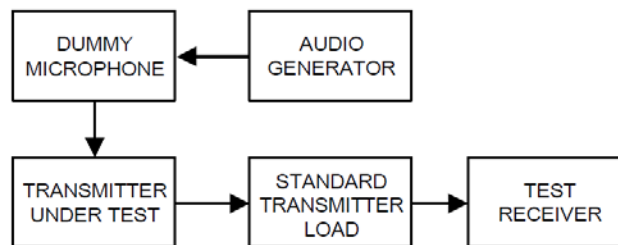

Test Data: 12.5 kHz FM Audio Frequency Response & Low Pass Filter

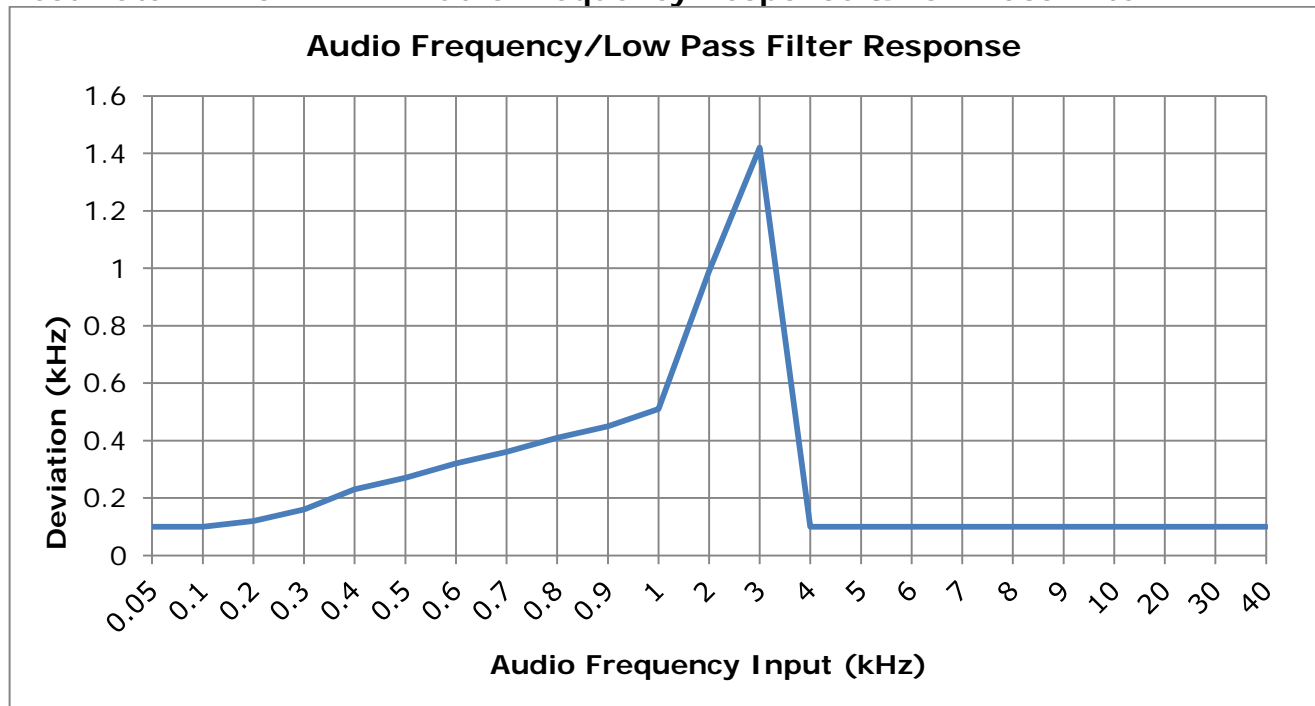

MODULATION LIMITING

Rule Part No.: 2.1047(b)

Requirements:

(b) *Equipment which employs modulation limiting.* A curve or family of curves showing the percentage of modulation versus the modulation input voltage shall be supplied. The information submitted shall be sufficient to show modulation limiting capability throughout the range of modulating frequencies and input modulating signal levels employed.

Test Procedure: TIA 603-E, 2.2.3

Note: The test method alone is not sufficient to meet the standard of FCC Pt. 2.1047(b). Deviation (kHz), as recorded from test equipment, has been converted into percentage as required above.

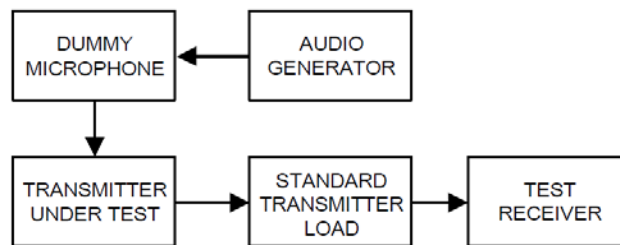

Test Data: 12.5 kHz FM Modulation Limiting

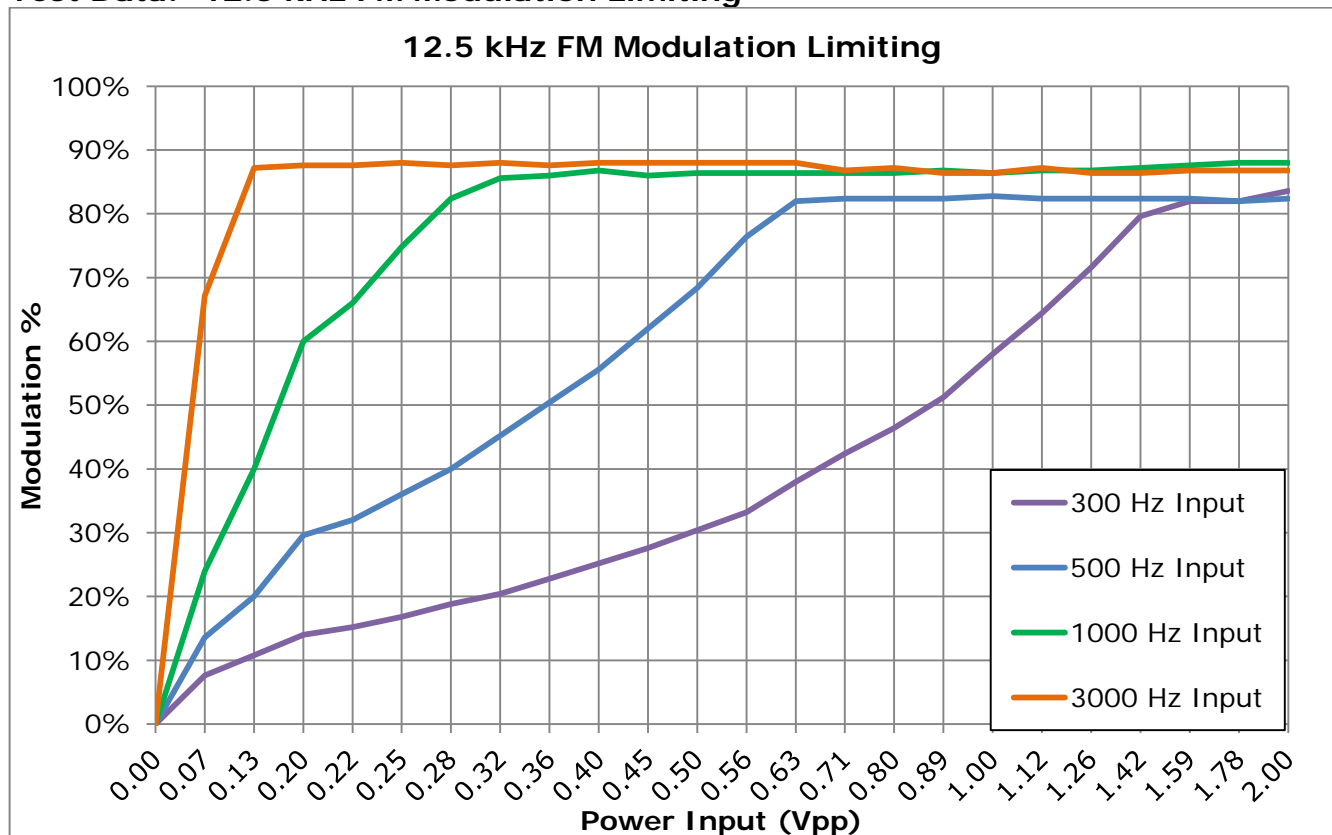

OCCUPIED BANDWIDTH

FCC Rule Parts: 2.1049 (c)

(c) Radiotelephone transmitters equipped with a device to limit modulation or peak envelope power shall be modulated as follows. For single sideband and independent sideband transmitters, the input level of the modulating signal shall be 10 dB greater than that necessary to produce rated peak envelope power.

(1) Other than single sideband or independent sideband transmitters—when modulated by a 2500 Hz tone at an input level 16 dB greater than that necessary to produce 50 percent modulation. The input level shall be established at the frequency of maximum response of the audio modulating circuit.

Method of Measurement: ANSI C63.26, 5.4.4 (using Test Setup from TIA 603-E 2.2.11, below)

Note: The receiver's automatic 99% Occupied Bandwidth function was used. The function is identical in operation to ANSI C63.26, 5.4.4, Step e).

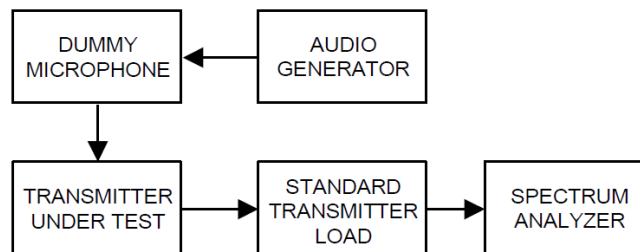

OCCUPIED BANDWIDTH 99%

Test Data: 11K2F3E (Narrowband Analog FM Voice)



| | | | | | | | |
|---------|--------|---------------|------------------|-----|--------|--------|-------|
| Ref Lvl | 44 dBm | Marker 1 [T1] | 40.69 dBm | RBW | 300 Hz | RF Att | 20 dB |
| | | | 459.99382515 MHz | VBW | 3 kHz | | |
| | | | | SWT | 1.4 s | Unit | dBm |

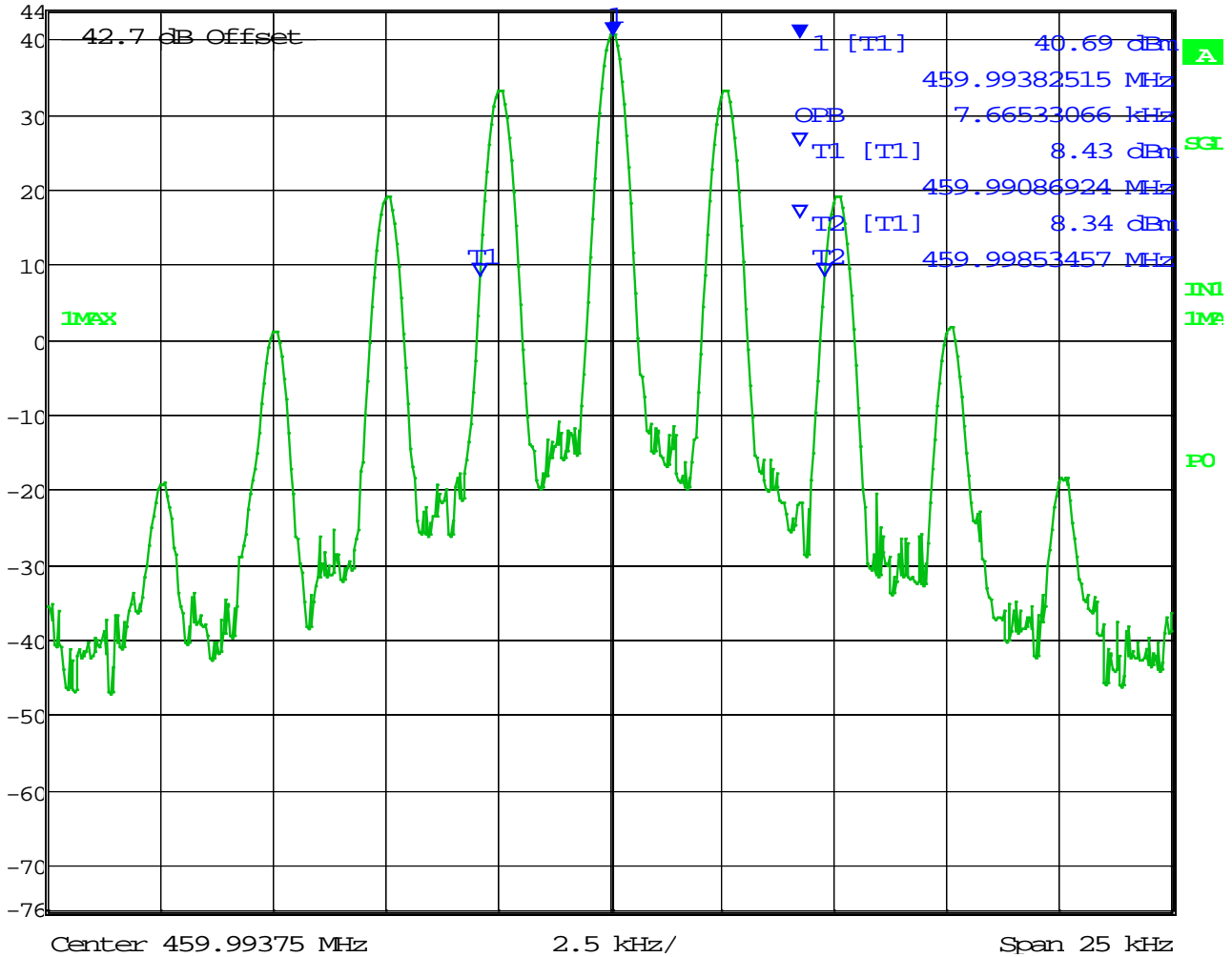

Date: 1.JAN.1997 02:26:53

99% OBW = 7.67 kHz

OCCUPIED BANDWIDTH 99%

Test Data: 8K10F1E/F1D (C4FM Voice/Data)



| | | | | | | | |
|---------|--------|---------------|------------------|-----|--------|--------|-------|
| Ref Lvl | 44 dBm | Marker 1 [T1] | 39.91 dBm | RBW | 300 Hz | RF Att | 20 dB |
| | | | 459.99407565 MHz | VBW | 3 kHz | | |
| | | | | SWT | 1.4 s | Unit | dBm |

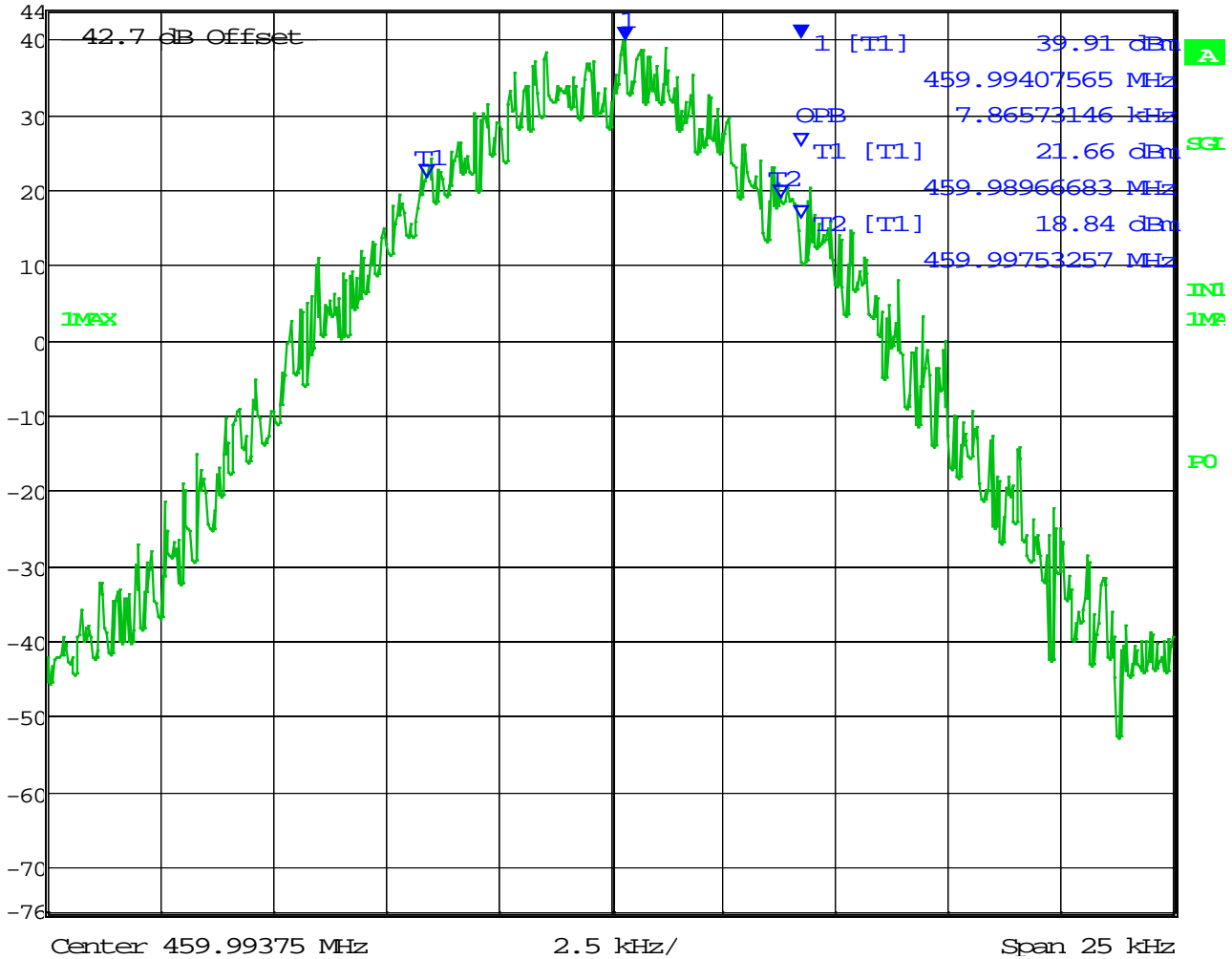

Date: 1.JAN.1997 02:29:30

99% OBW = 7.87 kHz

Result: Meets Requirements

SPURIOUS EMISSIONS AT ANTENNA TERMINALS (CONDUCTED)

FCC Rule Parts: 2.1051(a), 22.359(a)

Requirements:

(a) *Out of band emissions.* The power of any emission outside of the authorized operating frequency ranges must be attenuated below the transmitting power (P) by a factor of at least $43 + 10 \log (P)$ dB.

The limit below conforms to FCC CFR 47 Part 90.210(d)(3) and in all cases is more strict than that set forth in this rulepart. Please refer below:

FCC Rule Parts: 90.210(d)(3)

(3) On any frequency removed from the center of the authorized bandwidth by a displacement frequency (f_d in kHz) of more than 12.5 kHz: At least $50 + 10 \log (P)$ dB or 70 dB, whichever is the lesser attenuation.

Method of Measurement: ANSI/TIA-603-E

Test Procedure: TIA 603-E, 2.2.13

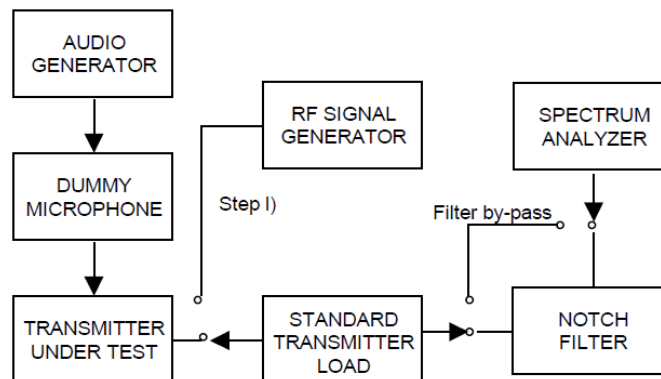

SPURIOUS EMISSIONS - NARROWBAND FM (12.5 kHz)

Test Data: 454.00625 MHz

| Spurious Conducted Emissions, Narrowband FM (12.5 kHz), Mask D Limit (≥250% Authorized BW) | High Power | | Med Power | | Low Power | |
|--|-------------|----------------|-------------|----------------|-------------|----------------|
| | dBm | 44.00 | dBm | 40.16 | dBm | 30.17 |
| | Watts | 25.12 | Watts | 10.38 | Watts | 1.04 |
| | Limit (dBm) | -20 | Limit (dBm) | -20 | Limit (dBm) | -20 |
| Frequency (MHz) | Peak (dBm) | Margin (dB) | Peak (dBm) | Margin (dB) | Peak (dBm) | Margin (dB) |
| Fundamental 454.0063 | 44.00 | 0.00 | 40.16 | 0.00 | 30.17 | 0.00 |
| 2nd Harmonic 908.0125 | -32.91 | 12.91 | -30.81 | 10.81 | -31.32 | 11.32 |
| 3rd Harmonic 1362.0188 | -42.88 | 22.88 | -51.90 | 31.90 | -54.49 | 34.49 |
| 4th Harmonic 1816.0250 | -49.27 | 29.27 | -53.93 | 33.93 | -57.98 | 37.98 |
| 5th Harmonic 2270.0313 | -57.10 | 37.10 | -56.22 | 36.22 | -53.06 | 33.06 |
| 6th Harmonic 2724.0375 | -61.70 | 41.7 * | -61.20 | 41.20 | -63.20 | 43.2 * |
| 7th Harmonic 3178.0438 | -61.56 | 41.56 * | -61.50 | 41.5 * | -63.06 | 43.06 * |
| 8th Harmonic 3632.0500 | -61.58 | 41.58 * | -61.52 | 41.52 * | -63.08 | 43.08 * |
| 9th Harmonic 4086.0563 | -61.31 | 41.31 * | -61.25 | 41.25 * | -62.81 | 42.81 * |
| 10th Harmonic 4540.0625 | -60.97 | 40.97 * | -60.91 | 40.91 * | -62.47 | 42.47 * |

* Indicates Noise Floor of Measurement

SPURIOUS EMISSIONS AT ANTENNA TERMINALS

Test Data: 454.99375 MHz

| Spurious Conducted Emissions, Narrowband FM (12.5 kHz), Mask D Limit (≥250% Authorized BW) | High Power | | Med Power | | Low Power | |
|--|-------------|----------------|-------------|----------------|-------------|----------------|
| | dBm | 44.00 | dBm | 40.16 | dBm | 30.17 |
| | Watts | 25.12 | Watts | 10.38 | Watts | 1.04 |
| | Limit (dBm) | -20 | Limit (dBm) | -20 | Limit (dBm) | -20 |
| Frequency (MHz) | Peak (dBm) | Margin (dB) | Peak (dBm) | Margin (dB) | Peak (dBm) | Margin (dB) |
| Fundamental 454.9938 | 44.00 | 0.00 | 40.16 | 0.00 | 30.17 | 0.00 |
| 2nd Harmonic 909.9875 | -32.60 | 12.60 | -29.16 | 9.16 | -30.07 | 10.07 |
| 3rd Harmonic 1364.9813 | -42.71 | 22.71 | -49.15 | 29.15 | -54.25 | 34.25 |
| 4th Harmonic 1819.9750 | -48.69 | 28.69 | -54.25 | 34.25 | -57.89 | 37.89 |
| 5th Harmonic 2274.9688 | -54.31 | 34.31 | -53.85 | 33.85 | -52.73 | 32.73 |
| 6th Harmonic 2729.9625 | -61.20 | 41.20 | -61.66 | 41.66 | -63.20 | 43.2 * |
| 7th Harmonic 3184.9563 | -61.56 | 41.56 * | -61.50 | 41.5 * | -63.06 | 43.06 * |
| 8th Harmonic 3639.9500 | -61.58 | 41.58 * | -61.52 | 41.52 * | -63.08 | 43.08 * |
| 9th Harmonic 4094.9438 | -61.31 | 41.31 * | -61.25 | 41.25 * | -62.81 | 42.81 * |
| 10th Harmonic 4549.9375 | -60.97 | 40.97 * | -60.91 | 40.91 * | -62.47 | 42.47 * |

* Indicates Noise Floor of Measurement

SPURIOUS EMISSIONS AT ANTENNA TERMINALS

Test Data: 456.00625 MHz

| Spurious Conducted Emissions, Narrowband FM (12.5 kHz), Mask D Limit (≥250% Authorized BW) | High Power | | Med Power | | Low Power | |
|--|-------------|----------------|-------------|----------------|-------------|----------------|
| | dBm | 44.00 | dBm | 40.16 | dBm | 30.17 |
| | Watts | 25.12 | Watts | 10.38 | Watts | 1.04 |
| | Limit (dBm) | -20 | Limit (dBm) | -20 | Limit (dBm) | -20 |
| Frequency (MHz) | Peak (dBm) | Margin (dB) | Peak (dBm) | Margin (dB) | Peak (dBm) | Margin (dB) |
| Fundamental 456.0063 | 44.00 | 0.00 | 40.16 | 0.00 | 30.17 | 0.00 |
| 2nd Harmonic 912.0125 | -32.47 | 12.47 | -29.26 | 9.26 | -30.23 | 10.23 |
| 3rd Harmonic 1368.0188 | -42.96 | 22.96 | -49.12 | 29.12 | -54.55 | 34.55 |
| 4th Harmonic 1824.0250 | -48.87 | 28.87 | -54.59 | 34.59 | -56.99 | 36.99 |
| 5th Harmonic 2280.0313 | -55.05 | 35.05 | -54.84 | 34.84 | -52.46 | 32.46 |
| 6th Harmonic 2736.0375 | -61.81 | 41.81 | -61.75 | 41.75 | -63.20 | 43.2 * |
| 7th Harmonic 3192.0438 | -61.56 | 41.56 * | -61.50 | 41.5 * | -63.06 | 43.06 * |
| 8th Harmonic 3648.0500 | -61.58 | 41.58 * | -61.52 | 41.52 * | -63.08 | 43.08 * |
| 9th Harmonic 4104.0563 | -61.31 | 41.31 * | -61.25 | 41.25 * | -62.81 | 42.81 * |
| 10th Harmonic 4560.0625 | -60.97 | 40.97 * | -60.91 | 40.91 * | -62.47 | 42.47 * |

* Indicates Noise Floor of Measurement

SPURIOUS EMISSIONS AT ANTENNA TERMINALS

Test Data: 459.99375 MHz

| Spurious Conducted Emissions, Narrowband FM (12.5 kHz), Mask D Limit (≥250% Authorized BW) | High Power | | Med Power | | Low Power | |
|--|-------------|----------------|-------------|----------------|-------------|----------------|
| | dBm | 44.00 | dBm | 40.16 | dBm | 30.17 |
| | Watts | 25.12 | Watts | 10.38 | Watts | 1.04 |
| | Limit (dBm) | -20 | Limit (dBm) | -20 | Limit (dBm) | -20 |
| Frequency (MHz) | Peak (dBm) | Margin (dB) | Peak (dBm) | Margin (dB) | Peak (dBm) | Margin (dB) |
| Fundamental 459.9938 | 44.00 | 0.00 | 40.16 | 0.00 | 30.17 | 0.00 |
| 2nd Harmonic 919.9875 | -32.45 | 12.45 | -31.04 | 11.04 | -31.80 | 11.80 |
| 3rd Harmonic 1379.9813 | -43.61 | 23.61 | -49.12 | 29.12 | -53.85 | 33.85 |
| 4th Harmonic 1839.9750 | -51.29 | 31.29 | -56.32 | 36.32 | -57.12 | 37.12 |
| 5th Harmonic 2299.9688 | -55.28 | 35.28 | -53.69 | 33.69 | -53.29 | 33.29 |
| 6th Harmonic 2759.9625 | -61.85 | 41.85 | -60.57 | 40.57 | -63.20 | 43.2 * |
| 7th Harmonic 3219.9563 | -61.56 | 41.56 * | -61.50 | 41.5 * | -63.06 | 43.06 * |
| 8th Harmonic 3679.9500 | -61.58 | 41.58 * | -61.52 | 41.52 * | -63.08 | 43.08 * |
| 9th Harmonic 4139.9438 | -61.31 | 41.31 * | -61.25 | 41.25 * | -62.81 | 42.81 * |
| 10th Harmonic 4599.9375 | -60.97 | 40.97 * | -60.91 | 40.91 * | -62.47 | 42.47 * |

* Indicates Noise Floor of Measurement

SPURIOUS EMISSIONS AT ANTENNA TERMINALS

Test Data: 470.00625 MHz

| Spurious Conducted Emissions, Narrowband FM (12.5 kHz), Mask D Limit (≥250% Authorized BW) | High Power | | Med Power | | Low Power | |
|--|-------------|----------------|-------------|----------------|-------------|----------------|
| | dBm | 44.00 | dBm | 40.16 | dBm | 30.17 |
| | Watts | 25.12 | Watts | 10.38 | Watts | 1.04 |
| | Limit (dBm) | -20 | Limit (dBm) | -20 | Limit (dBm) | -20 |
| Frequency (MHz) | Peak (dBm) | Margin (dB) | Peak (dBm) | Margin (dB) | Peak (dBm) | Margin (dB) |
| Fundamental 470.0063 | 44.00 | 0.00 | 40.16 | 0.00 | 30.17 | 0.00 |
| 2nd Harmonic 940.0125 | -39.20 | 19.20 | -35.84 | 15.84 | -36.12 | 16.12 |
| 3rd Harmonic 1410.0188 | -47.42 | 27.42 | -51.49 | 31.49 | -51.34 | 31.34 |
| 4th Harmonic 1880.0250 | -48.95 | 28.95 | -54.07 | 34.07 | -55.73 | 35.73 |
| 5th Harmonic 2350.0313 | -54.82 | 34.82 | -54.62 | 34.62 | -57.50 | 37.50 |
| 6th Harmonic 2820.0375 | -61.67 | 41.67 | -61.64 | 41.64 * | -63.20 | 43.2 * |
| 7th Harmonic 3290.0438 | -61.56 | 41.56 * | -61.50 | 41.5 * | -63.06 | 43.06 * |
| 8th Harmonic 3760.0500 | -61.58 | 41.58 * | -61.52 | 41.52 * | -63.08 | 43.08 * |
| 9th Harmonic 4230.0563 | -61.31 | 41.31 * | -61.25 | 41.25 * | -62.81 | 42.81 * |
| 10th Harmonic 4700.0625 | -60.97 | 40.97 * | -60.91 | 40.91 * | -62.47 | 42.47 * |

* Indicates Noise Floor of Measurement

SPURIOUS EMISSIONS AT ANTENNA TERMINALS

Test Data: 475.0000 MHz

| Spurious Conducted Emissions, Narrowband FM (12.5 kHz), Mask D Limit (≥250% Authorized BW) | High Power | | Med Power | | Low Power | |
|--|-------------|----------------|-------------|----------------|-------------|----------------|
| | dBm | 44.00 | dBm | 40.16 | dBm | 30.17 |
| | Watts | 25.12 | Watts | 10.38 | Watts | 1.04 |
| | Limit (dBm) | -20 | Limit (dBm) | -20 | Limit (dBm) | -20 |
| Frequency (MHz) | Peak (dBm) | Margin (dB) | Peak (dBm) | Margin (dB) | Peak (dBm) | Margin (dB) |
| Fundamental 475.0000 | 44.00 | 0.00 | 40.16 | 0.00 | 30.17 | 0.00 |
| 2nd Harmonic 950.0000 | -39.87 | 19.87 | -36.49 | 16.49 | -37.14 | 17.14 |
| 3rd Harmonic 1425.0000 | -49.80 | 29.80 | -52.48 | 32.48 | -50.38 | 30.38 |
| 4th Harmonic 1900.0000 | -53.20 | 33.20 | -53.05 | 33.05 | -56.87 | 36.87 |
| 5th Harmonic 2375.0000 | -52.54 | 32.54 | -55.18 | 35.18 | -57.74 | 37.74 |
| 6th Harmonic 2850.0000 | -61.70 | 41.7 * | -61.64 | 41.64 * | -63.20 | 43.2 * |
| 7th Harmonic 3325.0000 | -61.56 | 41.56 * | -61.50 | 41.5 * | -63.06 | 43.06 * |
| 8th Harmonic 3800.0000 | -61.58 | 41.58 * | -61.52 | 41.52 * | -63.08 | 43.08 * |
| 9th Harmonic 4275.0000 | -61.31 | 41.31 * | -61.25 | 41.25 * | -62.81 | 42.81 * |
| 10th Harmonic 4750.0000 | -60.97 | 40.97 * | -60.91 | 40.91 * | -62.47 | 42.47 * |

* Indicates Noise Floor of Measurement

SPURIOUS EMISSIONS AT ANTENNA TERMINALS

Test Data: 479.99375 MHz

| Spurious Conducted Emissions, Narrowband FM (12.5 kHz), Mask D Limit (≥250% Authorized BW) | High Power | | Med Power | | Low Power | |
|--|-------------|----------------|-------------|----------------|-------------|----------------|
| | dBm | 44.00 | dBm | 40.16 | dBm | 30.17 |
| | Watts | 25.12 | Watts | 10.38 | Watts | 1.04 |
| | Limit (dBm) | -20 | Limit (dBm) | -20 | Limit (dBm) | -20 |
| Frequency (MHz) | Peak (dBm) | Margin (dB) | Peak (dBm) | Margin (dB) | Peak (dBm) | Margin (dB) |
| Fundamental 479.9938 | 44.00 | 0.00 | 40.16 | 0.00 | 30.17 | 0.00 |
| 2nd Harmonic 959.9875 | -40.73 | 20.73 | -37.10 | 17.10 | -37.37 | 17.37 |
| 3rd Harmonic 1439.9813 | -49.67 | 29.67 | -53.12 | 33.12 | -51.26 | 31.26 |
| 4th Harmonic 1919.9750 | -51.23 | 31.23 | -53.80 | 33.80 | -56.66 | 36.66 |
| 5th Harmonic 2399.9688 | -56.43 | 36.43 | -57.69 | 37.69 | -59.99 | 39.99 |
| 6th Harmonic 2879.9625 | -61.70 | 41.7 * | -61.64 | 41.64 * | -63.20 | 43.2 * |
| 7th Harmonic 3359.9563 | -61.56 | 41.56 * | -61.50 | 41.5 * | -63.06 | 43.06 * |
| 8th Harmonic 3839.9500 | -61.58 | 41.58 * | -61.52 | 41.52 * | -63.08 | 43.08 * |
| 9th Harmonic 4319.9438 | -61.31 | 41.31 * | -61.25 | 41.25 * | -62.81 | 42.81 * |
| 10th Harmonic 4799.9375 | -60.97 | 40.97 * | -60.91 | 40.91 * | -62.47 | 42.47 * |

* Indicates Noise Floor of Measurement

Result: Meets Requirement

SPURIOUS EMISSIONS – P25 Phase I C4FM

Test Data: 454.00625 MHz

| Spurious Conducted Emissions, C4FM, Mask D Limit (≥250% Authorized BW) | High Power | | Med Power | | Low Power | |
|--|-------------|----------------|-------------|----------------|-------------|----------------|
| | dBm | 44.00 | dBm | 40.16 | dBm | 30.17 |
| | Watts | 25.12 | Watts | 10.38 | Watts | 1.04 |
| | Limit (dBm) | -20 | Limit (dBm) | -20 | Limit (dBm) | -20 |
| Frequency (MHz) | Peak (dBm) | Margin (dB) | Peak (dBm) | Margin (dB) | Peak (dBm) | Margin (dB) |
| Fundamental 454.0063 | 44.00 | 0.00 | 40.16 | 0.00 | 30.17 | 0.00 |
| 2nd Harmonic 908.0125 | -39.31 | 19.31 | -35.94 | 15.94 | -35.93 | 15.93 |
| 3rd Harmonic 1362.0188 | -42.61 | 22.61 | -47.33 | 27.33 | -53.23 | 33.23 |
| 4th Harmonic 1816.0250 | -53.80 | 33.80 | -57.79 | 37.79 | -61.37 | 41.37 |
| 5th Harmonic 2270.0313 | -53.57 | 33.57 | -54.50 | 34.50 | -52.12 | 32.12 |
| 6th Harmonic 2724.0375 | -61.67 | 41.67 | -61.64 | 41.64 * | -63.20 | 43.2 * |
| 7th Harmonic 3178.0438 | -61.56 | 41.56 * | -61.39 | 41.39 | -63.06 | 43.06 * |
| 8th Harmonic 3632.0500 | -61.58 | 41.58 * | -61.52 | 41.52 * | -63.08 | 43.08 * |
| 9th Harmonic 4086.0563 | -61.31 | 41.31 * | -61.25 | 41.25 * | -62.81 | 42.81 * |
| 10th Harmonic 4540.0625 | -61.18 | 41.18 | -60.91 | 40.91 * | -62.47 | 42.47 * |

* Indicates Noise Floor of Measurement

SPURIOUS EMISSIONS AT ANTENNA TERMINALS

Test Data: 454.99375 MHz

| Spurious Conducted Emissions, C4FM, Mask D Limit (≥250% Authorized BW) | High Power | | Med Power | | Low Power | |
|--|-------------|----------------|-------------|----------------|-------------|----------------|
| | dBm | 44.00 | dBm | 40.16 | dBm | 30.17 |
| | Watts | 25.12 | Watts | 10.38 | Watts | 1.04 |
| | Limit (dBm) | -20 | Limit (dBm) | -20 | Limit (dBm) | -20 |
| Frequency (MHz) | Peak (dBm) | Margin (dB) | Peak (dBm) | Margin (dB) | Peak (dBm) | Margin (dB) |
| Fundamental 454.9938 | 44.00 | 0.00 | 40.16 | 0.00 | 30.17 | 0.00 |
| 2nd Harmonic 909.9875 | -32.89 | 12.89 | -36.55 | 16.55 | -37.64 | 17.64 |
| 3rd Harmonic 1364.9813 | -43.42 | 23.42 | -50.04 | 30.04 | -52.91 | 32.91 |
| 4th Harmonic 1819.9750 | -54.00 | 34.00 | -58.76 | 38.76 | -61.54 | 41.54 |
| 5th Harmonic 2274.9688 | -54.08 | 34.08 | -54.77 | 34.77 | -52.85 | 32.85 |
| 6th Harmonic 2729.9625 | -61.16 | 41.16 | -61.64 | 41.64 * | -63.20 | 43.2 * |
| 7th Harmonic 3184.9563 | -61.56 | 41.56 * | -61.50 | 41.5 * | -63.06 | 43.06 * |
| 8th Harmonic 3639.9500 | -61.58 | 41.58 * | -61.52 | 41.52 * | -63.08 | 43.08 * |
| 9th Harmonic 4094.9438 | -61.31 | 41.31 * | -61.25 | 41.25 * | -62.81 | 42.81 * |
| 10th Harmonic 4549.9375 | -60.97 | 40.97 * | -60.91 | 40.91 * | -62.47 | 42.47 * |

* Indicates Noise Floor of Measurement

SPURIOUS EMISSIONS AT ANTENNA TERMINALS

Test Data: 456.00625 MHz

| Spurious Conducted Emissions, C4FM, Mask D Limit (≥250% Authorized BW) | High Power | | Med Power | | Low Power | |
|--|-------------|----------------|-------------|----------------|-------------|----------------|
| | dBm | 44.00 | dBm | 40.16 | dBm | 30.17 |
| | Watts | 25.12 | Watts | 10.38 | Watts | 1.04 |
| | Limit (dBm) | -20 | Limit (dBm) | -20 | Limit (dBm) | -20 |
| Frequency (MHz) | Peak (dBm) | Margin (dB) | Peak (dBm) | Margin (dB) | Peak (dBm) | Margin (dB) |
| Fundamental 456.0063 | 44.00 | 0.00 | 40.16 | 0.00 | 30.17 | 0.00 |
| 2nd Harmonic 912.0125 | -35.28 | 15.28 | -33.66 | 13.66 | -40.92 | 20.92 |
| 3rd Harmonic 1368.0188 | -46.22 | 26.22 | -48.88 | 28.88 | -53.52 | 33.52 |
| 4th Harmonic 1824.0250 | -53.02 | 33.02 | -59.80 | 39.80 | -60.90 | 40.90 |
| 5th Harmonic 2280.0313 | -53.28 | 33.28 | -55.35 | 35.35 | -53.03 | 33.03 |
| 6th Harmonic 2736.0375 | -62.04 | 42.04 | -62.15 | 42.15 | -63.20 | 43.2 * |
| 7th Harmonic 3192.0438 | -61.56 | 41.56 * | -61.50 | 41.5 * | -63.06 | 43.06 * |
| 8th Harmonic 3648.0500 | -62.62 | 42.62 | -61.52 | 41.52 * | -63.08 | 43.08 * |
| 9th Harmonic 4104.0563 | -61.31 | 41.31 * | -61.25 | 41.25 * | -62.81 | 42.81 * |
| 10th Harmonic 4560.0625 | -60.97 | 40.97 * | -61.06 | 41.06 | -62.47 | 42.47 * |

* Indicates Noise Floor of Measurement

SPURIOUS EMISSIONS AT ANTENNA TERMINALS

Test Data: 459.99375 MHz

| Spurious Conducted Emissions, C4FM, Mask D Limit (≥250% Authorized BW) | High Power | | Med Power | | Low Power | |
|--|-------------|----------------|-------------|----------------|-------------|----------------|
| | dBm | 44.00 | dBm | 40.16 | dBm | 30.17 |
| | Watts | 25.12 | Watts | 10.38 | Watts | 1.04 |
| | Limit (dBm) | -20 | Limit (dBm) | -20 | Limit (dBm) | -20 |
| Frequency (MHz) | Peak (dBm) | Margin (dB) | Peak (dBm) | Margin (dB) | Peak (dBm) | Margin (dB) |
| Fundamental 459.9938 | 44.00 | 0.00 | 40.16 | 0.00 | 30.17 | 0.00 |
| 2nd Harmonic 919.9875 | -43.28 | 23.28 | -33.39 | 13.39 | -34.24 | 14.24 |
| 3rd Harmonic 1379.9813 | -45.86 | 25.86 | -49.01 | 29.01 | -51.88 | 31.88 |
| 4th Harmonic 1839.9750 | -53.59 | 33.59 | -55.03 | 35.03 | -59.70 | 39.70 |
| 5th Harmonic 2299.9688 | -55.97 | 35.97 | -58.52 | 38.52 | -54.62 | 34.62 |
| 6th Harmonic 2759.9625 | -62.17 | 42.17 | -60.25 | 40.25 | -63.20 | 43.2 * |
| 7th Harmonic 3219.9563 | -61.56 | 41.56 * | -61.50 | 41.5 * | -63.06 | 43.06 * |
| 8th Harmonic 3679.9500 | -61.58 | 41.58 * | -61.52 | 41.52 * | -63.08 | 43.08 * |
| 9th Harmonic 4139.9438 | -61.31 | 41.31 * | -61.25 | 41.25 * | -62.81 | 42.81 * |
| 10th Harmonic 4599.9375 | -60.97 | 40.97 * | -60.91 | 40.91 * | -62.47 | 42.47 * |

* Indicates Noise Floor of Measurement

SPURIOUS EMISSIONS AT ANTENNA TERMINALS

Test Data: 470.00625 MHz

| Spurious Conducted Emissions, C4FM, Mask D Limit ($\geq 250\%$ Authorized BW) | High Power | | Med Power | | Low Power | |
|--|-------------|----------------|-------------|----------------|-------------|----------------|
| | dBm | 44.00 | dBm | 40.16 | dBm | 30.17 |
| | Watts | 25.12 | Watts | 10.38 | Watts | 1.04 |
| | Limit (dBm) | -20 | Limit (dBm) | -20 | Limit (dBm) | -20 |
| Frequency (MHz) | Peak (dBm) | Margin (dB) | Peak (dBm) | Margin (dB) | Peak (dBm) | Margin (dB) |
| Fundamental 470.0063 | 44.00 | 0.00 | 40.16 | 0.00 | 30.17 | 0.00 |
| 2nd Harmonic 940.0125 | -36.55 | 16.55 | -33.76 | 13.76 | -35.10 | 15.10 |
| 3rd Harmonic 1410.0188 | -46.77 | 26.77 | -50.05 | 30.05 | -50.86 | 30.86 |
| 4th Harmonic 1880.0250 | -53.42 | 33.42 | -54.56 | 34.56 | -59.36 | 39.36 |
| 5th Harmonic 2350.0313 | -52.70 | 32.70 | -55.24 | 35.24 | -58.43 | 38.43 |
| 6th Harmonic 2820.0375 | -62.39 | 42.39 | -61.64 | 41.64 * | -63.20 | 43.2 * |
| 7th Harmonic 3290.0438 | -61.56 | 41.56 * | -61.50 | 41.5 * | -63.06 | 43.06 * |
| 8th Harmonic 3760.0500 | -61.58 | 41.58 * | -61.52 | 41.52 * | -63.08 | 43.08 * |
| 9th Harmonic 4230.0563 | -61.31 | 41.31 * | -61.25 | 41.25 * | -62.81 | 42.81 * |
| 10th Harmonic 4700.0625 | -60.97 | 40.97 * | -60.91 | 40.91 * | -62.47 | 42.47 * |

* Indicates Noise Floor of Measurement

SPURIOUS EMISSIONS AT ANTENNA TERMINALS

Test Data: 475.0000 MHz

| Spurious Conducted Emissions, C4FM, Mask D Limit ($\geq 250\%$ Authorized BW) | High Power | | Med Power | | Low Power | |
|--|-------------|----------------|-------------|----------------|-------------|----------------|
| | dBm | 44.00 | dBm | 40.16 | dBm | 30.17 |
| | Watts | 25.12 | Watts | 10.38 | Watts | 1.04 |
| | Limit (dBm) | -20 | Limit (dBm) | -20 | Limit (dBm) | -20 |
| Frequency (MHz) | Peak (dBm) | Margin (dB) | Peak (dBm) | Margin (dB) | Peak (dBm) | Margin (dB) |
| Fundamental 475.0000 | 44.00 | 0.00 | 40.16 | 0.00 | 30.17 | 0.00 |
| 2nd Harmonic 950.0000 | -36.63 | 16.63 | -34.49 | 14.49 | -35.51 | 15.51 |
| 3rd Harmonic 1425.0000 | -48.67 | 28.67 | -51.55 | 31.55 | -51.74 | 31.74 |
| 4th Harmonic 1900.0000 | -51.29 | 31.29 | -53.02 | 33.02 | -54.59 | 34.59 |
| 5th Harmonic 2375.0000 | -53.47 | 33.47 | -56.15 | 36.15 | -61.06 | 41.06 |
| 6th Harmonic 2850.0000 | -61.70 | 41.7 * | -61.64 | 41.64 * | -63.20 | 43.2 * |
| 7th Harmonic 3325.0000 | -61.56 | 41.56 * | -61.50 | 41.5 * | -63.06 | 43.06 * |
| 8th Harmonic 3800.0000 | -61.58 | 41.58 * | -61.35 | 41.35 | -63.08 | 43.08 * |
| 9th Harmonic 4275.0000 | -61.31 | 41.31 * | -61.25 | 41.25 * | -62.81 | 42.81 * |
| 10th Harmonic 4750.0000 | -60.97 | 40.97 * | -60.91 | 40.91 * | -62.47 | 42.47 * |

* Indicates Noise Floor of Measurement

SPURIOUS EMISSIONS AT ANTENNA TERMINALS

Test Data: 479.99375 MHz

| Spurious Conducted Emissions, C4FM, Mask D Limit ($\geq 250\%$ Authorized BW) | High Power | | Med Power | | Low Power | |
|--|-------------|----------------|-------------|----------------|-------------|----------------|
| | dBm | 44.00 | dBm | 40.16 | dBm | 30.17 |
| | Watts | 25.12 | Watts | 10.38 | Watts | 1.04 |
| | Limit (dBm) | -20 | Limit (dBm) | -20 | Limit (dBm) | -20 |
| Frequency (MHz) | Peak (dBm) | Margin (dB) | Peak (dBm) | Margin (dB) | Peak (dBm) | Margin (dB) |
| Fundamental 479.9938 | 44.00 | 0.00 | 40.16 | 0.00 | 30.17 | 0.00 |
| 2nd Harmonic 959.9875 | -38.13 | 18.13 | -37.11 | 17.11 | -38.11 | 18.11 |
| 3rd Harmonic 1439.9813 | -50.45 | 30.45 | -53.47 | 33.47 | -52.33 | 32.33 |
| 4th Harmonic 1919.9750 | -49.58 | 29.58 | -53.36 | 33.36 | -55.26 | 35.26 |
| 5th Harmonic 2399.9688 | -56.78 | 36.78 | -57.56 | 37.56 | -57.55 | 37.55 |
| 6th Harmonic 2879.9625 | -61.70 | 41.7 * | -61.64 | 41.64 * | -62.46 | 42.46 |
| 7th Harmonic 3359.9563 | -61.56 | 41.56 * | -61.50 | 41.5 * | -63.06 | 43.06 * |
| 8th Harmonic 3839.9500 | -61.58 | 41.58 * | -61.52 | 41.52 * | -63.08 | 43.08 * |
| 9th Harmonic 4319.9438 | -61.31 | 41.31 * | -61.25 | 41.25 * | -62.81 | 42.81 * |
| 10th Harmonic 4799.9375 | -60.97 | 40.97 * | -60.91 | 40.91 * | -62.47 | 42.47 * |

* Indicates Noise Floor of Measurement

Result: Meets Requirement

FIELD STRENGTH OF SPURIOUS EMISSIONS

FCC Rule Parts: 2.1053(a), 22.359(a)

Method of Measurement: ANSI C63.26, 5.5.4

Test Site Setup:

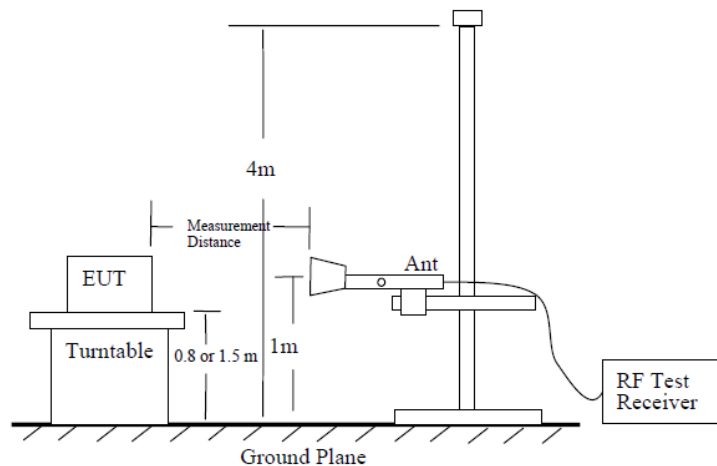

EUT Orientation(s):

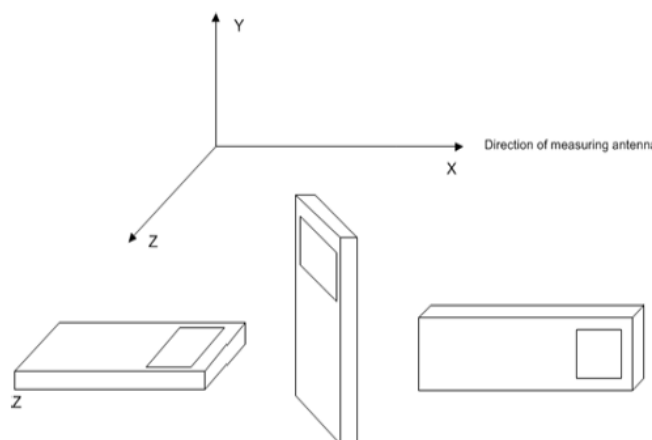

Note: The tabulated data shows the results of the radiated field strength emissions test. The spectrum was scanned from the lowest frequency generated internally to at least the tenth harmonic of the fundamental. This test was conducted in accordance with the standard listed above using the substitution method. Measurements were made at the test site of TIMCO ENGINEERING, INC. located at 849 NW State Road 45, Newberry, FL 32669. The measurements below represent the worst case of all the frequencies tested.

Note: The six (6) highest emissions or more of each worst-case operational modes of the EUT are represented below. Emissions 20 dB below the limit are not required to be reported.

FIELD STRENGTH OF SPURIOUS EMISSIONS

Test Data: 454.00625 MHz

Low Power

| Power Output | | Limit | | |
|----------------|------------------------|------------------|-----------|-------------|
| dBm | Watts | dBc | dBm | |
| 30.17 | 1.04 | 50.17 | -20.00 | |
| Tuned Freq MHz | Emission Frequency MHz | Antenna Polarity | ERP (dBm) | Margin (dB) |
| 454.01 | 908.01 | H | -26.987 | 6.99 |
| 454.01 | 908.01 | V | -32.877 | 12.88 |
| 454.01 | 1362.02 | V | -39.357 | 19.36 |
| 454.01 | 1816.03 | V | -39.987 | 19.99 |
| 454.01 | 2270.03 | H | -37.867 | 17.87 |
| 454.01 | 2270.03 | V | -39.717 | 19.72 |

Medium Power

| Power Output | | Limit | | |
|----------------|------------------------|------------------|-----------|-------------|
| dBm | Watts | dBc | dBm | |
| 40.16 | 10.38 | 60.16 | -20.00 | |
| Tuned Freq MHz | Emission Frequency MHz | Antenna Polarity | ERP (dBm) | Margin (dB) |
| 454.01 | 908.01 | V | -32.027 | 12.03 |
| 454.01 | 908.01 | H | -27.257 | 7.26 |
| 454.01 | 1362.02 | V | -39.087 | 19.09 |
| 454.01 | 1362.02 | H | -40.187 | 20.19 |
| 454.01 | 1816.03 | H | -39.597 | 19.60 |
| 454.01 | 1816.03 | V | -39.237 | 19.24 |
| 454.01 | 2270.03 | V | -33.527 | 13.53 |
| 454.01 | 2270.03 | H | -37.757 | 17.76 |

FIELD STRENGTH OF SPURIOUS EMISSIONS

High Power

| Power Output | | Limit | | |
|----------------|------------------------|------------------|----------------|-------------|
| dBm | Watts | dBc | dBm | |
| 44 | 25.12 | 64 | -20.00 | |
| Tuned Freq MHz | Emission Frequency MHz | Antenna Polarity | ERP (dBm) | Margin (dB) |
| 454.01 | 908.01 | H | -27.297 | 7.30 |
| 454.01 | 908.01 | V | -27.297 | 7.30 |
| 454.01 | 2724.04 | H | -31.507 | 11.51 |
| 454.01 | 2724.04 | V | -32.197 | 12.20 |
| 454.01 | 3178.04 | V | -34.907 | 14.91 |
| 454.01 | 1362.02 | V | -38.287 | 18.29 |
| 454.01 | 1816.03 | V | -35.877 | 15.88 |
| 454.01 | 1816.03 | H | -39.227 | 19.23 |
| 454.01 | 2270.03 | H | -33.627 | 13.63 |
| 454.01 | 2270.03 | V | -32.197 | 12.20 |
| 454.01 | 3632.05 | V | -34.627 | 14.63 |

FIELD STRENGTH OF SPURIOUS EMISSIONS

Test Data: 454.99375 MHz

Low Power

| Power Output | | Limit | | |
|----------------|------------------------|------------------|-----------|-------------|
| dBm | Watts | dBc | dBm | |
| 30.17 | 1.04 | 50.17 | -20.00 | |
| Tuned Freq MHz | Emission Frequency MHz | Antenna Polarity | ERP (dBm) | Margin (dB) |
| 454.99 | 909.99 | V | -31.957 | 11.96 |
| 454.99 | 909.99 | H | -25.198 | 5.20 |
| 454.99 | 1364.98 | V | -36.200 | 16.20 |
| 454.99 | 1364.98 | H | -32.267 | 12.27 |
| 454.99 | 1819.97 | H | -32.098 | 12.10 |
| 454.99 | 1819.97 | V | -33.408 | 13.41 |
| 454.99 | 2274.97 | V | -28.665 | 8.66 |
| 454.99 | 2274.97 | H | -27.070 | 7.07 |
| 454.99 | 2729.96 | H | -36.092 | 16.09 |
| 454.99 | 2729.96 | V | -35.336 | 15.34 |
| 454.99 | 3184.96 | V | -30.961 | 10.96 |
| 454.99 | 3184.96 | H | -31.137 | 11.14 |
| 454.99 | 3639.95 | H | -33.398 | 13.40 |
| 454.99 | 3639.95 | V | -32.837 | 12.84 |
| 454.99 | 4094.94 | V | -32.311 | 12.31 |
| 454.99 | 4094.94 | H | -31.814 | 11.81 |
| 454.99 | 4549.94 | H | -31.345 | 11.34 |
| 454.99 | 4549.94 | V | -30.899 | 10.90 |

FIELD STRENGTH OF SPURIOUS EMISSIONS

Medium Power

| Power Output | | Limit | | |
|----------------|------------------------|------------------|-----------|-------------|
| dBm | Watts | dBc | dBm | |
| 40.16 | 10.38 | 60.16 | -20.00 | |
| Tuned Freq MHz | Emission Frequency MHz | Antenna Polarity | ERP (dBm) | Margin (dB) |
| 454.99 | 909.99 | H | -28.067 | 8.07 |
| 454.99 | 909.99 | V | -28.258 | 8.26 |
| 454.99 | 1364.98 | V | -33.200 | 13.20 |
| 454.99 | 1364.98 | V | -32.257 | 12.26 |
| 454.99 | 1819.97 | V | -33.968 | 13.97 |
| 454.99 | 1819.97 | H | -30.208 | 10.21 |
| 454.99 | 1819.97 | V | -26.145 | 6.14 |
| 454.99 | 1819.97 | H | -26.080 | 6.08 |
| 454.99 | 2274.97 | H | -32.802 | 12.80 |
| 454.99 | 2274.97 | V | -33.576 | 13.58 |
| 454.99 | 2729.96 | V | -29.101 | 9.10 |
| 454.99 | 2729.96 | H | -31.227 | 11.23 |
| 454.99 | 3184.96 | H | -33.398 | 13.40 |
| 454.99 | 3184.96 | V | -32.837 | 12.84 |
| 454.99 | 3639.95 | V | -32.311 | 12.31 |
| 454.99 | 3639.95 | H | -31.814 | 11.81 |
| 454.99 | 4094.94 | H | -31.345 | 11.34 |
| 454.99 | 4094.94 | V | -30.899 | 10.90 |
| 454.99 | 4549.94 | V | -30.475 | 10.48 |
| 454.99 | 4549.94 | H | -30.071 | 10.07 |

FIELD STRENGTH OF SPURIOUS EMISSIONS

High Power

| Power Output | | Limit | | |
|----------------|------------------------|------------------|-----------|-------------|
| dBm | Watts | dBc | dBm | |
| 44 | 25.12 | 64 | -20.00 | |
| Tuned Freq MHz | Emission Frequency MHz | Antenna Polarity | ERP (dBm) | Margin (dB) |
| 454.99 | 909.99 | V | -27.747 | 7.75 |
| 454.99 | 909.99 | H | -23.308 | 3.31 |
| 454.99 | 1364.98 | H | -32.660 | 12.66 |
| 454.99 | 1364.98 | V | -29.557 | 9.56 |
| 454.99 | 1819.97 | V | -31.978 | 11.98 |
| 454.99 | 1819.97 | H | -29.268 | 9.27 |
| 454.99 | 2274.97 | H | -25.465 | 5.46 |
| 454.99 | 2274.97 | V | -25.560 | 5.56 |
| 454.99 | 2729.96 | V | -36.092 | 16.09 |
| 454.99 | 2729.96 | H | -35.336 | 15.34 |
| 454.99 | 3184.96 | H | -30.841 | 10.84 |
| 454.99 | 3184.96 | V | -30.597 | 10.60 |
| 454.99 | 3639.95 | V | -33.398 | 13.40 |
| 454.99 | 3639.95 | H | -32.837 | 12.84 |
| 454.99 | 4094.94 | H | -32.311 | 12.31 |
| 454.99 | 4094.94 | V | -31.814 | 11.81 |
| 454.99 | 4549.94 | V | -31.345 | 11.34 |
| 454.99 | 4549.94 | H | -30.899 | 10.90 |

FIELD STRENGTH OF SPURIOUS EMISSIONS

Test Data: 456.00625 MHz

Low Power

| Power Output | | Limit | | |
|----------------|------------------------|------------------|-----------|-------------|
| dBm | Watts | dBc | dBm | |
| 30.17 | 1.04 | 50.17 | -20.00 | |
| Tuned Freq MHz | Emission Frequency MHz | Antenna Polarity | ERP (dBm) | Margin (dB) |
| 456.01 | 912.01 | H | -25.997 | 6.00 |
| 456.01 | 912.01 | V | -26.018 | 6.02 |
| 456.01 | 1368.02 | H | -34.700 | 14.70 |
| 456.01 | 1368.02 | V | -35.687 | 15.69 |
| 456.01 | 1824.03 | V | -33.808 | 13.81 |
| 456.01 | 1824.03 | H | -31.348 | 11.35 |
| 456.01 | 2280.03 | H | -23.825 | 3.82 |
| 456.01 | 2280.03 | V | -32.300 | 12.30 |
| 456.01 | 2736.04 | V | -36.092 | 16.09 |
| 456.01 | 2736.04 | H | -35.336 | 15.34 |
| 456.01 | 3192.04 | V | -28.741 | 8.74 |
| 456.01 | 3192.04 | H | -31.967 | 11.97 |
| 456.01 | 3648.05 | H | -33.398 | 13.40 |
| 456.01 | 3648.05 | V | -32.837 | 12.84 |
| 456.01 | 4104.06 | V | -32.311 | 12.31 |
| 456.01 | 4104.06 | H | -31.814 | 11.81 |
| 456.01 | 4560.06 | H | -31.345 | 11.34 |
| 456.01 | 4560.06 | V | -30.899 | 10.90 |

FIELD STRENGTH OF SPURIOUS EMISSIONS

Medium Power

| Power Output | | Limit | | |
|----------------|------------------------|------------------|-----------|-------------|
| dBm | Watts | dBc | dBm | |
| 40.16 | 10.38 | 60.16 | -20.00 | |
| Tuned Freq MHz | Emission Frequency MHz | Antenna Polarity | ERP (dBm) | Margin (dB) |
| 456.01 | 912.01 | V | -28.277 | 8.28 |
| 456.01 | 912.01 | H | -24.038 | 4.04 |
| 456.01 | 1368.02 | H | -37.270 | 17.27 |
| 456.01 | 1368.02 | V | -36.207 | 16.21 |
| 456.01 | 1824.03 | V | -28.668 | 8.67 |
| 456.01 | 1824.03 | H | -32.948 | 12.95 |
| 456.01 | 2280.03 | H | -27.335 | 7.33 |
| 456.01 | 2280.03 | V | -26.770 | 6.77 |
| 456.01 | 2736.04 | V | -33.022 | 13.02 |
| 456.01 | 2736.04 | H | -32.686 | 12.69 |
| 456.01 | 3192.04 | H | -34.641 | 14.64 |
| 456.01 | 3192.04 | V | -33.997 | 14.00 |
| 456.01 | 3648.05 | V | -33.398 | 13.40 |
| 456.01 | 3648.05 | H | -32.837 | 12.84 |
| 456.01 | 4104.06 | H | -32.311 | 12.31 |
| 456.01 | 4104.06 | V | -31.814 | 11.81 |
| 456.01 | 4560.06 | V | -31.345 | 11.34 |
| 456.01 | 4560.06 | H | -30.899 | 10.90 |

FIELD STRENGTH OF SPURIOUS EMISSIONS

High Power

| Power Output | | Limit | | |
|----------------|------------------------|------------------|-----------|-------------|
| dBm | Watts | dBc | dBm | |
| 44 | 25.12 | 64 | -20.00 | |
| Tuned Freq MHz | Emission Frequency MHz | Antenna Polarity | ERP (dBm) | Margin (dB) |
| 456.01 | 912.01 | H | -27.117 | 7.12 |
| 456.01 | 912.01 | V | -25.178 | 5.18 |
| 456.01 | 1368.02 | H | -30.290 | 10.29 |
| 456.01 | 1368.02 | V | -34.297 | 14.30 |
| 456.01 | 1824.03 | V | -28.318 | 8.32 |
| 456.01 | 1824.03 | H | -33.828 | 13.83 |
| 456.01 | 2280.03 | H | -28.815 | 8.81 |
| 456.01 | 2280.03 | V | -30.810 | 10.81 |
| 456.01 | 2736.04 | V | -36.092 | 16.09 |
| 456.01 | 2736.04 | H | -35.336 | 15.34 |
| 456.01 | 3192.04 | H | -34.641 | 14.64 |
| 456.01 | 3192.04 | V | -33.997 | 14.00 |
| 456.01 | 3648.05 | V | -33.398 | 13.40 |
| 456.01 | 3648.05 | H | -32.837 | 12.84 |
| 456.01 | 4104.06 | H | -32.311 | 12.31 |
| 456.01 | 4104.06 | V | -31.814 | 11.81 |
| 456.01 | 4560.06 | V | -31.345 | 11.34 |
| 456.01 | 4560.06 | H | -30.899 | 10.90 |

FIELD STRENGTH OF SPURIOUS EMISSIONS

Test Data: 459.99375 MHz

Low Power

| Power Output | | Limit | | |
|----------------|------------------------|------------------|-----------|-------------|
| dBm | Watts | dBc | dBm | |
| 30.17 | 1.04 | 50.17 | -20.00 | |
| Tuned Freq MHz | Emission Frequency MHz | Antenna Polarity | ERP (dBm) | Margin (dB) |
| 459.99 | 919.99 | V | -25.957 | 5.96 |
| 459.99 | 919.99 | H | -26.128 | 6.13 |
| 459.99 | 1379.98 | V | -33.100 | 13.10 |
| 459.99 | 1379.98 | H | -33.467 | 13.47 |
| 459.99 | 1839.97 | H | -33.358 | 13.36 |
| 459.99 | 1839.97 | V | -32.418 | 12.42 |
| 459.99 | 2299.97 | V | -26.535 | 6.53 |
| 459.99 | 2299.97 | H | -25.050 | 5.05 |
| 459.99 | 2759.96 | H | -32.572 | 12.57 |
| 459.99 | 2759.96 | V | -33.146 | 13.15 |
| 459.99 | 3219.96 | V | -29.651 | 9.65 |
| 459.99 | 3219.96 | H | -31.617 | 11.62 |
| 459.99 | 3679.95 | H | -33.398 | 13.40 |
| 459.99 | 3679.95 | V | -32.837 | 12.84 |
| 459.99 | 4139.94 | V | -32.311 | 12.31 |
| 459.99 | 4139.94 | H | -31.814 | 11.81 |
| 459.99 | 4599.94 | H | -31.345 | 11.34 |
| 459.99 | 4599.94 | V | -30.899 | 10.90 |

FIELD STRENGTH OF SPURIOUS EMISSIONS

Medium Power

| Power Output | | Limit | | |
|----------------|------------------------|------------------|----------------|-------------|
| dBm | Watts | dBc | dBm | |
| 40.16 | 10.38 | 60.16 | -20.00 | |
| Tuned Freq MHz | Emission Frequency MHz | Antenna Polarity | ERP (dBm) | Margin (dB) |
| 459.99 | 919.99 | H | -28.847 | 8.85 |
| 459.99 | 919.99 | V | -21.238 | 1.24 |
| 459.99 | 1379.98 | V | -32.870 | 12.87 |
| 459.99 | 1379.98 | H | -33.037 | 13.04 |
| 459.99 | 1839.97 | V | -31.878 | 11.88 |
| 459.99 | 1839.97 | H | -33.018 | 13.02 |
| 459.99 | 2299.97 | H | -24.955 | 4.95 |
| 459.99 | 2299.97 | V | -27.510 | 7.51 |
| 459.99 | 2759.96 | V | -30.142 | 10.14 |
| 459.99 | 2759.96 | H | -32.586 | 12.59 |
| 459.99 | 3219.96 | H | -30.771 | 10.77 |
| 459.99 | 3219.96 | V | -29.827 | 9.83 |
| 459.99 | 3679.95 | V | -33.398 | 13.40 |
| 459.99 | 3679.95 | H | -32.837 | 12.84 |
| 459.99 | 4139.94 | H | -29.341 | 9.34 |
| 459.99 | 4139.94 | V | -31.814 | 11.81 |
| 459.99 | 4599.94 | V | -31.345 | 11.34 |
| 459.99 | 4599.94 | H | -30.899 | 10.90 |

FIELD STRENGTH OF SPURIOUS EMISSIONS

High Power

| Power Output | | Limit | | |
|----------------|------------------------|------------------|-----------|-------------|
| dBm | Watts | dBc | dBm | |
| 44 | 25.12 | 64 | -20.00 | |
| Tuned Freq MHz | Emission Frequency MHz | Antenna Polarity | ERP (dBm) | Margin (dB) |
| 459.99 | 919.99 | V | -28.157 | 8.16 |
| 459.99 | 919.99 | H | -25.918 | 5.92 |
| 459.99 | 1379.98 | H | -27.460 | 7.46 |
| 459.99 | 1379.98 | V | -28.607 | 8.61 |
| 459.99 | 1839.97 | V | -29.008 | 9.01 |
| 459.99 | 1839.97 | H | -30.278 | 10.28 |
| 459.99 | 2299.97 | H | -24.945 | 4.94 |
| 459.99 | 2299.97 | V | -25.260 | 5.26 |
| 459.99 | 2759.96 | V | -27.852 | 7.85 |
| 459.99 | 2759.96 | H | -23.746 | 3.75 |
| 459.99 | 3219.96 | H | -31.371 | 11.37 |
| 459.99 | 3219.96 | V | -32.237 | 12.24 |
| 459.99 | 3679.95 | V | -28.098 | 8.10 |
| 459.99 | 3679.95 | H | -29.457 | 9.46 |
| 459.99 | 4139.94 | H | -32.311 | 12.31 |
| 459.99 | 4139.94 | V | -31.814 | 11.81 |
| 459.99 | 4599.94 | V | -31.345 | 11.34 |
| 459.99 | 4599.94 | H | -30.899 | 10.90 |

FIELD STRENGTH OF SPURIOUS EMISSIONS

Test Data: 470.00625 MHz

Low Power

| Power Output | | Limit | | |
|----------------|------------------------|------------------|-----------|-------------|
| dBm | Watts | dBc | dBm | |
| 30.17 | 1.04 | 50.17 | -20.00 | |
| Tuned Freq MHz | Emission Frequency MHz | Antenna Polarity | ERP (dBm) | Margin (dB) |
| 470.01 | 940.01 | H | -21.067 | 1.07 |
| 470.01 | 940.01 | V | -20.147 | 0.15 |
| 470.01 | 2350.03 | V | -39.887 | 19.89 |
| 470.01 | 3290.04 | V | -39.567 | 19.57 |

Medium Power

| Power Output | | Limit | | |
|----------------|------------------------|------------------|-----------|-------------|
| dBm | Watts | dBc | dBm | |
| 40.16 | 10.38 | 60.16 | -20.00 | |
| Tuned Freq MHz | Emission Frequency MHz | Antenna Polarity | ERP (dBm) | Margin (dB) |
| 470.01 | 940.01 | V | -25.847 | 5.85 |
| 470.01 | 940.01 | H | -27.037 | 7.04 |
| 470.01 | 1410.02 | H | -40.287 | 20.29 |
| 470.01 | 1410.02 | V | -38.547 | 18.55 |
| 470.01 | 1880.03 | V | -37.917 | 17.92 |
| 470.01 | 1880.03 | H | -37.127 | 17.13 |
| 470.01 | 2350.03 | H | -33.917 | 13.92 |
| 470.01 | 2350.03 | V | -38.387 | 18.39 |
| 470.01 | 3290.04 | V | -40.107 | 20.11 |

High Power

| Power Output | | Limit | | |
|----------------|------------------------|------------------|-----------|-------------|
| dBm | Watts | dBc | dBm | |
| 44 | 25.12 | 64 | -20.00 | |
| Tuned Freq MHz | Emission Frequency MHz | Antenna Polarity | ERP (dBm) | Margin (dB) |
| 470.01 | 940.01 | H | -24.467 | 4.47 |
| 470.01 | 940.01 | V | -24.287 | 4.29 |
| 470.01 | 2350.03 | H | -39.757 | 19.76 |
| 470.01 | 3290.04 | V | -40.437 | 20.44 |

FIELD STRENGTH OF SPURIOUS EMISSIONS

Test Data: 475.00 MHz

Low Power

| Power Output | | Limit | | |
|----------------|------------------------|------------------|-----------|-------------|
| dBm | Watts | dBc | dBm | |
| 30.17 | 1.04 | 50.17 | -20.00 | |
| Tuned Freq MHz | Emission Frequency MHz | Antenna Polarity | ERP (dBm) | Margin (dB) |
| 475.00 | 950.00 | V | -27.477 | 7.48 |
| 475.00 | 950.00 | H | -30.147 | 10.15 |
| 475.00 | 1425.00 | H | -40.817 | 20.82 |
| 475.00 | 1425.00 | V | -38.707 | 18.71 |
| 475.00 | 2375.00 | H | -39.227 | 19.23 |
| 475.00 | 3325.00 | V | -39.877 | 19.88 |

Medium Power

| Power Output | | Limit | | |
|----------------|------------------------|------------------|-----------|-------------|
| dBm | Watts | dBc | dBm | |
| 40.16 | 10.38 | 60.16 | -20.00 | |
| Tuned Freq MHz | Emission Frequency MHz | Antenna Polarity | ERP (dBm) | Margin (dB) |
| 475.00 | 950.00 | H | -27.587 | 7.59 |
| 475.00 | 950.00 | V | -27.077 | 7.08 |
| 475.00 | 3325.00 | H | -40.227 | 20.23 |
| 475.00 | 1900.00 | H | -39.227 | 19.23 |

High Power

| Power Output | | Limit | | |
|----------------|------------------------|------------------|-----------|-------------|
| dBm | Watts | dBc | dBm | |
| 44 | 25.12 | 64 | -20.00 | |
| Tuned Freq MHz | Emission Frequency MHz | Antenna Polarity | ERP (dBm) | Margin (dB) |
| 475.00 | 950.00 | V | -25.330 | 5.33 |
| 475.00 | 950.00 | H | -28.167 | 8.17 |
| 475.00 | 1425.00 | V | -33.887 | 13.89 |
| 475.00 | 1425.00 | H | -34.277 | 14.28 |
| 475.00 | 2375.00 | V | -38.477 | 18.48 |
| 475.00 | 2375.00 | H | -40.507 | 20.51 |

FIELD STRENGTH OF SPURIOUS EMISSIONS

Test Data: 479.99375 MHz

Low Power

| Power Output | | Limit | | |
|----------------|------------------------|------------------|----------------|-------------|
| dBm | Watts | dBc | dBm | |
| 30.17 | 1.04 | 50.17 | -20.00 | |
| Tuned Freq MHz | Emission Frequency MHz | Antenna Polarity | ERP (dBm) | Margin (dB) |
| 479.99 | 959.99 | H | -24.907 | 4.91 |
| 479.99 | 959.99 | V | -21.487 | 1.49 |
| 479.99 | 2399.97 | V | -36.777 | 16.78 |
| 479.99 | 2399.97 | H | -40.497 | 20.50 |
| 479.99 | 1919.97 | H | -37.087 | 17.09 |
| 479.99 | 1919.97 | V | -36.647 | 16.65 |
| 479.99 | 1439.98 | V | -38.617 | 18.62 |

Medium Power

| Power Output | | Limit | | |
|----------------|------------------------|------------------|----------------|-------------|
| dBm | Watts | dBc | dBm | |
| 40.16 | 10.38 | 60.16 | -20.00 | |
| Tuned Freq MHz | Emission Frequency MHz | Antenna Polarity | ERP (dBm) | Margin (dB) |
| 479.99 | 959.99 | V | -21.147 | 1.15 |
| 479.99 | 959.99 | H | -24.317 | 4.32 |
| 479.99 | 1439.98 | H | -40.357 | 20.36 |
| 479.99 | 1439.98 | V | -39.117 | 19.12 |
| 479.99 | 1919.97 | H | -40.527 | 20.53 |
| 479.99 | 2399.97 | H | -39.737 | 19.74 |

FIELD STRENGTH OF SPURIOUS EMISSIONS

High Power

| Power Output | | Limit | | |
|----------------|------------------------|------------------|-----------|-------------|
| dBm | Watts | dBc | dBm | |
| 44 | 25.12 | 64 | -20.00 | |
| Tuned Freq MHz | Emission Frequency MHz | Antenna Polarity | ERP (dBm) | Margin (dB) |
| 479.99 | 959.99 | H | -25.547 | 5.55 |
| 479.99 | 959.99 | V | -29.078 | 9.08 |
| 479.99 | 1439.98 | V | -31.290 | 11.29 |
| 479.99 | 1439.98 | H | -33.677 | 13.68 |
| 479.99 | 1919.97 | H | -38.088 | 18.09 |
| 479.99 | 1919.97 | V | -38.548 | 18.55 |
| 479.99 | 2399.97 | V | -31.025 | 11.02 |
| 479.99 | 2399.97 | H | -33.460 | 13.46 |
| 479.99 | 2879.96 | H | -39.852 | 19.85 |
| 479.99 | 2879.96 | V | -33.256 | 13.26 |
| 479.99 | 3359.96 | H | -35.641 | 15.64 |
| 479.99 | 3359.96 | V | -33.567 | 13.57 |
| 479.99 | 3839.95 | V | -35.778 | 15.78 |
| 479.99 | 3839.95 | H | -40.177 | 20.18 |
| 479.99 | 4319.94 | H | -38.631 | 18.63 |
| 479.99 | 4319.94 | V | -38.134 | 18.13 |
| 479.99 | 4799.94 | V | -37.665 | 17.66 |
| 479.99 | 4799.94 | H | -37.219 | 17.22 |

FREQUENCY STABILITY

FCC Rule Parts: 2.1055(a)(2), 22.355

TABLE C-1—FREQUENCY TOLERANCE FOR TRANSMITTERS IN THE PUBLIC MOBILE SERVICES

| Frequency range (MHz) | Base, fixed (ppm) | Mobile >3 watts (ppm) | Mobile ≤3 watts (ppm) |
|-----------------------|-------------------|-----------------------|-----------------------|
| 450 to 512 | 2.5 | 5.0 | 5.0 |

The limit below conforms to FCC CFR 47 Part 90. 90.213 and in all cases is more strict than that set forth in this rulepart. Please refer below:

FCC Rule Parts: 90.213

MINIMUM FREQUENCY STABILITY

[Parts per million (ppm)]

| Frequency range (MHz) | Fixed and base stations | Mobile stations | |
|-----------------------|--------------------------------------|---------------------------|------------------------------|
| | | Over 2 watts output power | 2 watts or less output power |
| 421-512 | 7 ¹¹ 14 ¹⁴ 2.5 | 8 ⁵ | 8 ⁵ |

⁷In the 421-512 MHz band, fixed and base stations with a 12.5 kHz channel bandwidth must have a frequency stability of 1.5 ppm. Fixed and base stations with a 6.25 kHz channel bandwidth must have a frequency stability of 0.5 ppm.

⁸In the 421-512 MHz band, mobile stations designed to operate with a 12.5 kHz channel bandwidth must have a frequency stability of 2.5 ppm. Mobile stations designed to operate with a 6.25 kHz channel bandwidth must have a frequency stability of 1.0 ppm.

¹¹Paging transmitters operating on paging-only frequencies must operate with frequency stability of 5 ppm in the 150-174 MHz band and 2.5 ppm in the 421-512 MHz band.

¹⁴Control stations may operate with the frequency tolerance specified for associated mobile frequencies.

Method of Measurements: TIA 603-E, 2.2.2

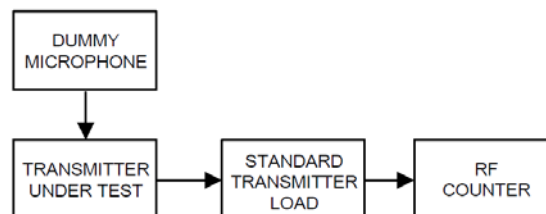

FREQUENCY STABILITY

Test Data: Frequency Error Measurement Plot

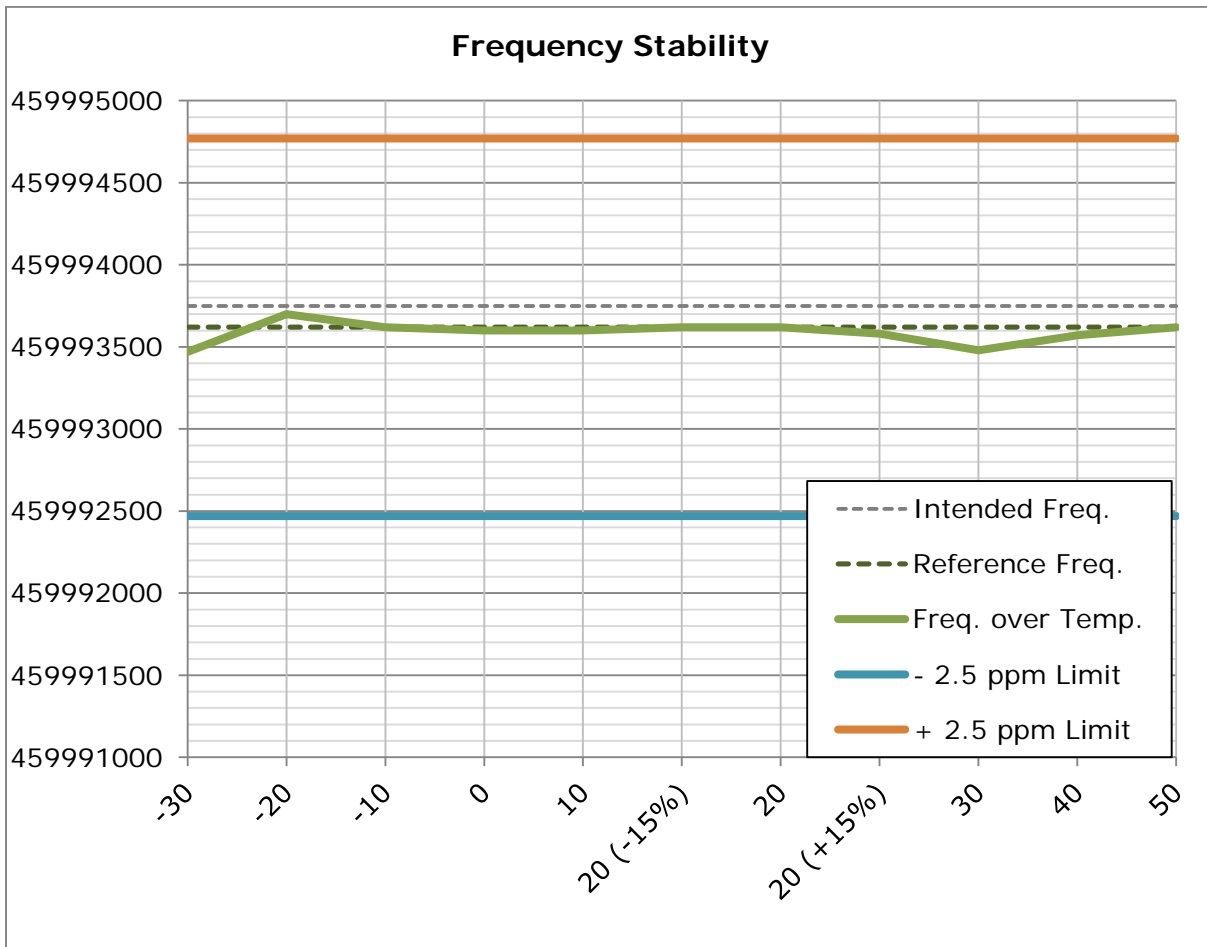

FREQUENCY STABILITY

Test Data: Frequency Error Measurement Table

| Limit: | | 2.5 ppm | | |
|------------------|------------------------|-------------------------|-----------------------------------|----------------|
| Temperature (°C) | Supplied Voltage (VDC) | Intended Frequency (Hz) | Measured Reference Frequency (Hz) | Deviation (Hz) |
| 20°C (reference) | 13.8 | 459993750 | 459993620 | 130 |

| @ 20°C (reference) | | | | |
|----------------------|------------------------|----------------|----------------|-------|
| Supplied Voltage (%) | Supplied Voltage (VDC) | Frequency (Hz) | Deviation (Hz) | PPM |
| -15% | 11.73 | 459993620 | 0 | 0.000 |
| 15% | 15.87 | 459993580 | 40 | 0.087 |

| Temperature (°C) | Supplied Voltage (VDC) | Frequency (Hz) | Deviation (Hz) | PPM |
|------------------|------------------------|----------------|----------------|--------|
| 50 | 13.8 | 459993620 | 0.00000 | 0.000 |
| 40 | 13.8 | 459993570 | 50.00000 | 0.109 |
| 30 | 13.8 | 459993480 | 140.00000 | 0.304 |
| 20 | 13.8 | 459993620 | 0.00000 | 0.000 |
| 10 | 13.8 | 459993600 | 20.00000 | 0.043 |
| 0 | 13.8 | 459993600 | 20.00000 | 0.043 |
| -10 | 13.8 | 459993620 | 0.00000 | 0.000 |
| -20 | 13.8 | 459993700 | 80.00000 | -0.174 |
| -30 | 13.8 | 459993470 | 150.00000 | 0.326 |

RESULT: Meets Requirements

STATEMENT OF MEASUREMENT UNCERTAINTY

The data and results referenced in this document are true and accurate. The measurement uncertainty was calculated for all measurements listed in this test report according To CISPR 16-4 or ENTR 100-028 Specification for radio disturbance and immunity measuring apparatus and methods – Part 4: “Uncertainty in EMC Measurements” and is documented in the Timco Engineering, Inc. quality system according to DIN EN ISO/IEC 17025. Furthermore, component and process variability of devices similar to that tested may result in additional deviation. The manufacturer has the sole responsibility of continued compliance of the device.

Hereafter the best measurement capability for Timco Engineering, Inc. is reported:

| Test Items | Measurement Uncertainty | Notes |
|---|-------------------------|-------|
| RF Frequency Accuracy | ± 49.5 Hz | (1) |
| RF Conducted Power | ±0.93dB | (1) |
| Conducted spurious emission of transmitter valid up to 40GHz | ± 1.86dB | |
| Occupied Bandwidth | ± 2.65% | |
| Audio Frequency Response | ± 1.86dB | |
| Modulation limiting | ± 1.88% | |
| Radiated RF Power | ± 1.4dB | |
| Maximum frequency deviation: Within 300 Hz and 6kHz of audio freq. | ± 1.88% | |
| Within 6kHz and 25kHz of audio Freq. | ± 2.04% | |
| Rad Emissions Sub Meth up to 26.5GHz | ± 2.14dB | |
| Adjacent channel power | ± 1.47dB | (1) |
| Transient Frequency Response | ± 1.88% | |
| Temperature | ± 1.0°C | (1) |
| Humidity | ± 5.0% | |

This uncertainty represents an expanded uncertainty expressed at approximately the 95% confidence level using a coverage factor of $k=1.96$.

EMC EQUIPMENT LIST

| Device | Manufacturer | Model | Serial Number | Cal/Char Date | Due Date |
|--|--------------------|------------------------------|--|---------------|----------|
| Coaxial Cable - BMBM-0065-01 Black DC-2G | Belden | | BMBM-0065-01 | 07/18/16 | 07/18/18 |
| Antenna: Biconical 1096 | Eaton | 94455-1 | 1096 | 08/01/17 | 08/01/19 |
| Antenna: Log-Periodic 1122 | Electro-Metrics | LPA-25 | 1122 | 07/26/17 | 07/26/19 |
| Temperature Chamber LARGE | Tenney Engineering | TTRC | 11717-7 | 09/01/16 | 09/01/18 |
| Frequency Counter Small Chamber | HP | 5385A | 3242A07460 | 08/22/17 | 08/22/19 |
| Coaxial Cable - Chamber 3 cable set (backup) | Micro-Coax | Chamber 3 cable set (backup) | KMKM-0244-02 KMKM-0670-01 KFKF-0197-00 | N/A | N/A |
| CHAMBER | Panashield | 3M | N/A | 04/25/16 | 5/31/18 |
| Antenna: Double-Ridged Horn/ETS Horn 2 | ETS-Lindgren | 3117 | 00041534 | 03/01/17 | 03/01/19 |
| Software: Field Strength Program | Timco | N/A | Version 4.10.7.0 | N/A | N/A |
| Antenna: Passive Loop | EMCO | 6512 | 9706-1211 | 07/26/17 | 07/26/19 |
| Type K J Thermometer | Martel | 303 | 080504494 | 11/02/17 | 11/02/19 |
| EMI Test Receiver R & S ESIB 40 | Rohde & Schwarz | ESIB 40 | 100274 | 08/18/16 | 08/18/18 |
| EMI Test Receiver R & S ESU 40 | Rohde & Schwarz | ESU 40 | 100320 | 04/01/16 | 04/01/19 |
| Attenuator N 20dB 20W DC-12G | Narda | 768-20-SP | 155 | 07/10/17 | 07/10/19 |
| Attenuator N 20dB 20W DC-12G | Narda | 768-20-SP | 344 | 07/10/17 | 07/10/19 |
| Attenuator N 30dB 100W DC-6G | Pasternack | PE7214-30 | #109 | 05/24/17 | 05/24/19 |
| Attenuator BNC 10dB DC-2G | MiniCircuits | HAT-10+ | #54 | 07/14/17 | 07/14/19 |
| Bore-sight Antenna Positioning Tower | Sunol Sciences | TLT2 | N/A | N/A | N/A |
| Tunable Notch Filter 250-850 MHz | Eagle | TNF-200 | 250-850 MHz (#19) | 11/19/17 | 11/19/19 |
| Terminator N 20W DC-18G | Narda | 8205 | #14 | 04/06/17 | 04/06/19 |
| Attenuator BNC 6dB 50Ohm DC-2G | Mini-Circuits | HAT-6+ | #53 | 07/14/17 | 07/14/19 |
| Attenuator N 30dB 100W DC-6G | Pasternack | PE7214-30 | #109 | 05/24/17 | 05/23/19 |
| DC Power Supply | HP | 6286A | 1744A03842 | N/A | N/A |
| Modulation Analyzer | HP | 8901A | 3050A05856 | 04/13/17 | 04/13/19 |
| Function Generator | Standford | DS340 | 25200 | 02/21/18 | 02/21/20 |
| Terminator N 20W DC-18G | Narda | 8205 | #14 | 04/06/17 | 04/06/19 |

*EMI RECEIVER SOFTWARE VERSION

The receiver firmware used was version 4.43 Service Pack 3

END OF TEST REPORT