



849 NW STATE ROAD 45
 NEWBERRY, FL 32669 USA
 PH: 888.472.2424 OR 352.472.5500
 FAX: 352.472.2030
 EMAIL: INFO@TIMCOENGR.COM
[HTTP://WWW.TIMCOENGR.COM](http://WWW.TIMCOENGR.COM)

FCC PART 90 TEST REPORT

APPLICANT	STANDARD COMMUNICATIONS Pty.Ltd.
	Locked Bag 2086 Nth Ryde NSW 1670 AUSTRALIA
FCC ID	TXJCM1039U
MODEL NUMBER	CM1039U
PRODUCT DESCRIPTION	RADIO TRANSCEIVER
DATE SAMPLE RECEIVED	2/25/2013
DATE TESTED	3/15/2013
TESTED BY	Nam Nguyen
APPROVED BY	Mario de Aranzeta
TIMCO REPORT NO.	351AUT13TestReport.doc
TEST RESULTS	<input checked="" type="checkbox"/> PASS <input type="checkbox"/> FAIL

**THE ATTACHED REPORT SHALL NOT BE REPRODUCED EXCEPT IN FULL
WITHOUT THE WRITTEN APPROVAL OF TIMCO ENGINEERING, INC.**





TABLE OF CONTENTS

GENERAL REMARKS.....3
GENERAL INFORMATION.....4
TEST PROCEDURES5
RF POWER OUTPUT.....6
MODULATION CHARACTERISTICS7
AUDIO FREQUENCY RESPONSE8
AUDIO LOW PASS FILTER.....9
AUDIO INPUT VERSUS MODULATION10
OCCUPIED BANDWIDTH.....11
SPURIOUS EMISSIONS AT ANTENNA TERMINALS (CONDUCTED).....19
FIELD STRENGTH OF SPURIOUS EMISSIONS22
FREQUENCY STABILITY.....25
TRANSIENT FREQUENCY BEHAVIOR26
EMC EQUIPMENT LIST29

GENERAL REMARKS

The attached report shall not be reproduced except in full without the written permission of Timco Engineering Inc.

The test results relate only to the items tested.

Summary

The device under test does:

- fulfill the general approval requirements as identified in this test report
 not fulfill the general approval requirements as identified in this test report

Attestations

This equipment has been tested in accordance with the standards identified in this test report. To the best of my knowledge and belief, these tests were performed using the measurement procedures described in this report.

All instrumentation and accessories used to test products for compliance to the indicated standards are calibrated regularly in accordance with ISO 17025: 2005 requirements.



Testing Certificate # 0955-01

I attest that the necessary measurements were made, under my supervision, at:

Timco Engineering Inc.
849 NW State Road 45
Newberry, FL 32669

Authorized Signatory Name:



Nam Nguyen
Project Manager/Testing Technician



Mario de Aranzeta C.E.T.
Compliance Engineer/ Lab. Supervisor

Date: April 30, 2013

Applicant: STANDARD COMMUNICATIONS Pty.Ltd.
FCC ID: TXJCM1039U
Report: s\STANDARD Comm Au\351AUT13\351AUT13TestReport.doc

GENERAL INFORMATION
DUT Specification

DUT Description	RADIO TRANSCEIVER
FCC ID	TXJCM1039U
Model Number	CM1039U
Serial Number	N/A
Operating Frequency	450 – 512 MHz
Test Frequencies	450.1, 481.1, and 511.9 MHz
Type of Emission	11K0F3E, 7K60F1D, 7K60F1E 7K60F1W, 7K60FXE, 7K60FXD
Modulation	FM, 4FSK
DUT Power Source	<input type="checkbox"/> 110–120Vac/50– 60Hz
	<input checked="" type="checkbox"/> DC Power 12V
	<input type="checkbox"/> Battery Operated Exclusively
Test Item	<input type="checkbox"/> Prototype
	<input checked="" type="checkbox"/> Pre-Production
	<input type="checkbox"/> Production
Type of Equipment	<input type="checkbox"/> Fixed
	<input checked="" type="checkbox"/> Mobile
	<input type="checkbox"/> Portable
Test Conditions	The temperature was 26°C with a relative humidity of 50%.
Modification to the DUT	None
Test Exercise	The DUT was placed in continuous transmit mode.
Applicable Standards	ANSI/TIA 603-C:2004, FCC CFR 47 Part 90, IC RSS-119, RSS-GEN
Test Facility	Timco Engineering Inc. at 849 NW State Road 45 Newberry, FL 32669 USA.

Applicant: STANDARD COMMUNICATIONS Pty.Ltd.
 FCC ID: TXJCM1039U
 Report: s\STANDARD Comm Au\351AUT13\351AUT13TestReport.doc

TEST PROCEDURES

Power Line Conducted Interference: The procedure used was ANSI/TIA 603-C:2004 using a 50uH LISN. Both lines were observed with the DUT transmitting. The bandwidth of the spectrum analyzer was 10 kHz with an appropriate sweep speed.

Bandwidth 20 dB: The measurements were made with the spectrum analyzer's resolution bandwidth (RBW) = 1 MHz and the video bandwidth (VBW) = 3 MHz and the span set as shown on plot.

Power Output: The RF power output was measured at the antenna feed point using a peak power meter.

Antenna Conducted Emissions: The RBW = 100 kHz, VBW = 300 kHz and the span set to 10.0 MHz and the spectrum was scanned from 30 MHz to the 10th harmonic of the fundamental. Above 1 GHz the resolution bandwidth was 1 MHz and the VBW = 3 MHz and the span to 50 MHz.

Radiation Interference: The test procedure used was ANSI/TIA 603-C:2004 using an Agilent spectrum receiver with pre-selector. The bandwidth (RBW) of the spectrum receiver was 100 kHz up to 1 GHz and 1 MHz above 1 GHz with an appropriate sweep speed. The VBW above 1 GHz was 3 MHz. The analyzer was calibrated in dB above a micro volt at the output of the antenna.

RF POWER OUTPUT

Rule Part No.: FCC Part 2.1046(a), IC RSS-119 4.1 and 5.4, RSS-GEN 4.8

Test Requirements:

Method of Measurement: RF power is measured by connecting a 50-ohm, resistive wattmeter to the RF output connector. With a nominal battery voltage, and the transmitter properly adjusted the RF output measures:

Test Setup Diagram:



Test Data:

OUTPUT POWER:

Tuned Frequency (MHz)	RF POWER (W)	
	HI	LOW
450.10	24.8	1.0
481.10	25.1	1.1
511.90	25.5	1.1

Part 2.1033 (C)(8) DC Input into the final amplifier

FOR LOW POWER SETTING INPUT POWER: $(12.0V)(1.7A) = 20.4$ Watts

FOR HIGH POWER SETTING INPUT POWER: $(12.0V)(6.1A) = 73.2$ Watts

MODULATION CHARACTERISTICS

Part 2.1033(c)

Part 2.1033(c) (4) Type of Emission: 11K2F3E, 7K60F1D, 7K60F1E, 7K60F1W, 7K60FXE, 7K60FXD

FCC Part 90.209

FCC Part 90.207

Type of Emission: 11K2F3E

$$B_n = 2M + 2DK$$

$$M = 3000$$

$$D = 2100$$

$$K=1$$

$$B_n = 2(3000)+2(2100) = 10.2k$$

The CM1039U Digital functions comply with DMR (Digital Mobile Radio).

Format: 2-slot TDMA

Modulation: 4FSK

Bandwidth: 12.5 kHz / 6.25 kHz

Data rate: 9,600bps / 4,800bps

Using the 99% bandwidth method yields a emission designator of:

7K60F1D, 7K60F1E, 7K60F1W, 7K60FXE, 7K60FXD

AUDIO FREQUENCY RESPONSE

Rule Part No.: FCC Part 2.1047(a)(b)

Test Requirements:

Method of Measurement:

The audio frequency response was measured in accordance with ANSI/TIA 603-C: 2004. A curve or equivalent data showing the frequency response of the audio modulating circuit over a range of 100 – 5000Hz shall be submitted. The audio frequency response curve is shown below.

AUDIO FREQUENCY RESPONSE PLOT

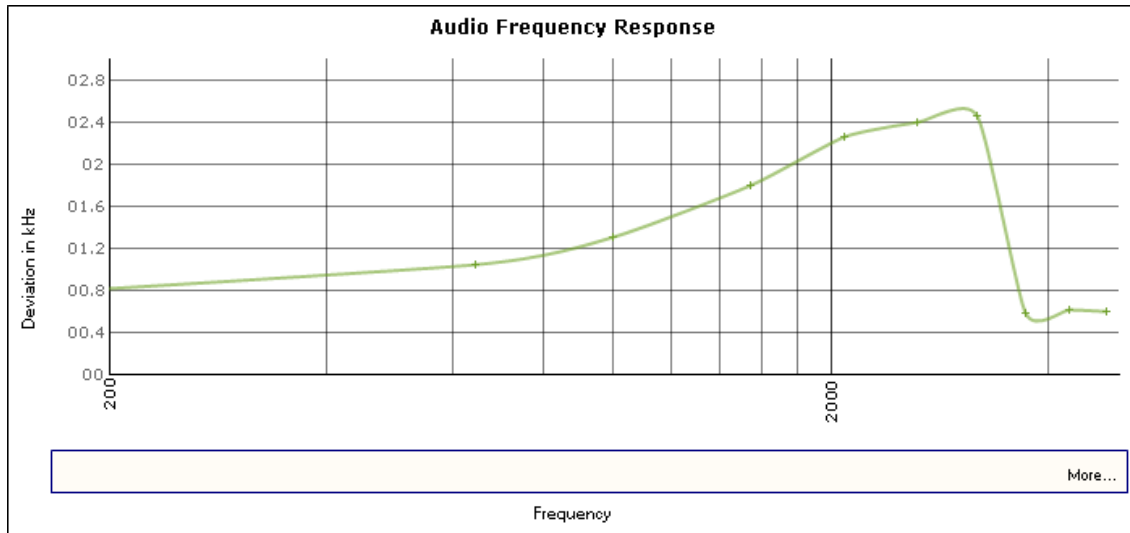

AUDIO LOW PASS FILTER

VOICE MODULATED COMMUNICATION EQUIPMENT

Part 2.1047(a) Voice modulated communication equipment: For equipment required to have an audio low-pass filter, a curve showing the frequency response of the filter, or of all the circuitry installed between the modulation limiter and the modulated stage shall be submitted.

AUDIO LOW PASS FILTER

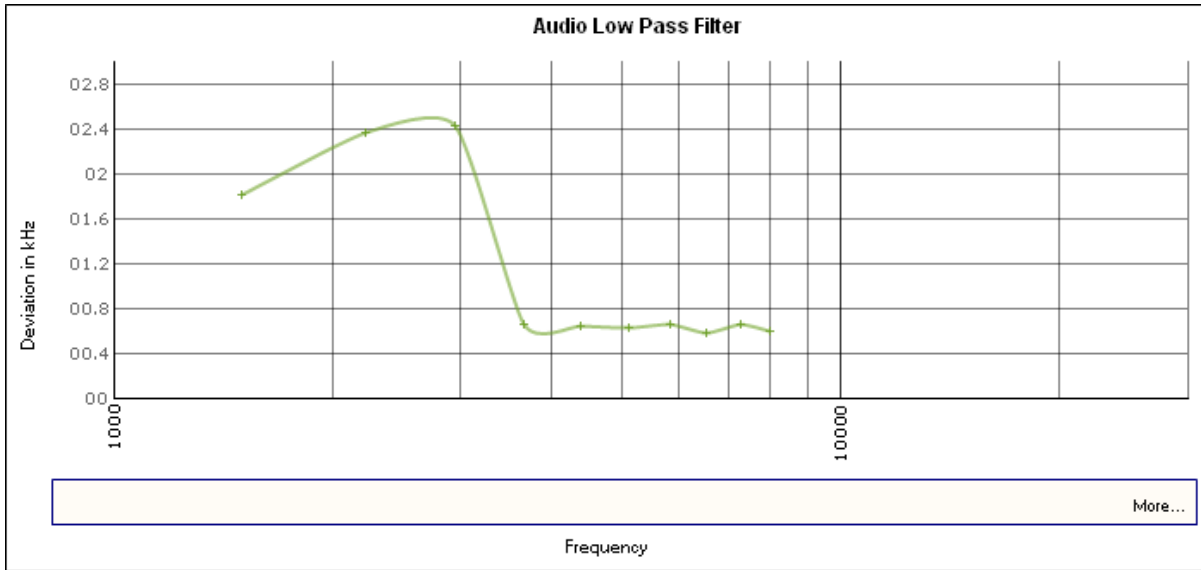

AUDIO INPUT VERSUS MODULATION

Rule Part No.: FCC Part 2.1047(b) & 90

Test Requirements:

Method of Measurement: **Modulation cannot exceed 100%**, The audio input level needed for a particular percentage of modulation was measured in accordance with ANSI/TIA 603-C:2004. The audio input curves versus modulation are shown below. Curves are provided for audio input frequencies of 300, 1000, and 2500 Hz.

Test data:

MODULATION LIMITING PLOT

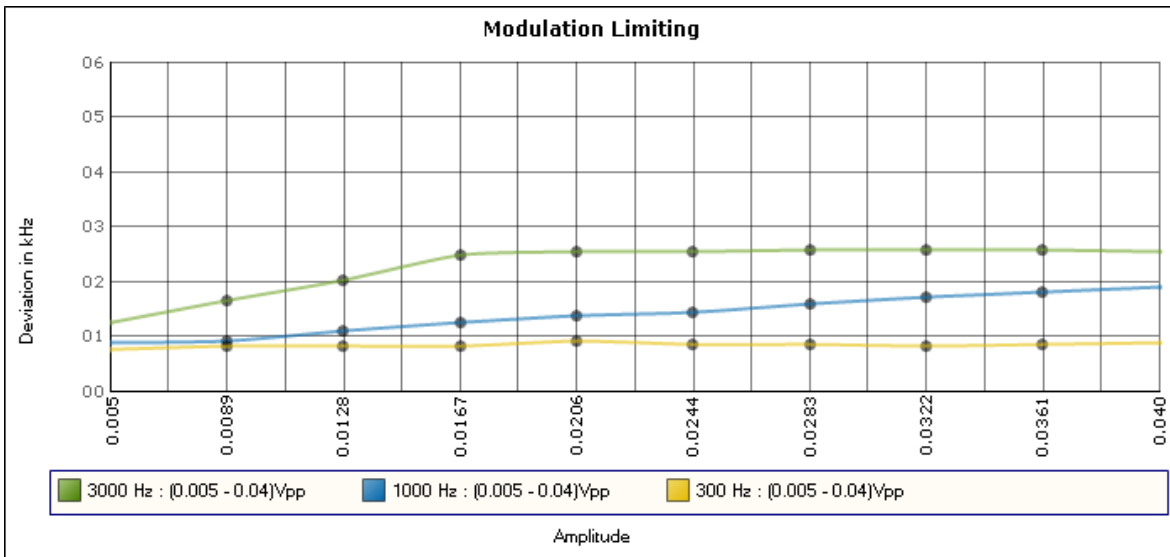

OCCUPIED BANDWIDTH

FCC Part 2.1049(c), EMISSION BANDWIDTH

Part 90.210(d) Emission Mask D - 12.5 kHz channel BW equipment.

For transmitters designed to operate with a 12.5 kHz channel bandwidth, any emission must be attenuated below the power (P) of the highest emission contained within the authorized bandwidth as follows:

- (1) On any frequency from the center of the authorized bandwidth f_0 to 5.625 kHz removed from f_0 : Zero dB.
- (2) On any frequency from the center of the authorized bandwidth by a displacement frequency (f_d in kHz) of more than 5.625 kHz but no more than 12.5 kHz: At least $7.27(f_d - 2.88 \text{ kHz})$ dB.
- (3) On any frequency removed from the center of the authorized bandwidth by a displacement frequency (f_d in kHz) of more than 12.5 kHz: At least $50 + 10\log(P)$ dB or 70 dB, whichever is the lesser attenuation.

Part 90.210(e) Emission Mask E - 6.25 kHz channel BW equipment.

For transmitters designed to operate with a 6.25 kHz bandwidth, any emission must be attenuated below the power (P) of the highest emission contained within the authorized bandwidth as follows:

- (1) On any frequency from the center of the authorized bandwidth f_0 to 3.0 kHz removed from f_0 : Zero dB.
- (2) On any frequency from the center of the authorized bandwidth by a displacement frequency (f_d in kHz) of more than 3.0 kHz but no more than 4.6 kHz: At least $30 + 16.67(f_d - 3.0 \text{ kHz})$ or $55 + 10 \text{ Log}(P)$ or 65, whichever is the lesser attenuation.
- (3) On any frequency removed from the center of the authorized bandwidth by more than 4.6kHz: At least $55 + 10\log(P)$ dB or 65 dB, whichever is the lesser attenuation.

OCCUPIED BANDWIDTH MEASUREMENT

Test procedure: ANSI/TIA-603-C:2004 para 2.2.11.

Test Setup Diagram:

OCCUPIED BANDWIDTH MEASUREMENT

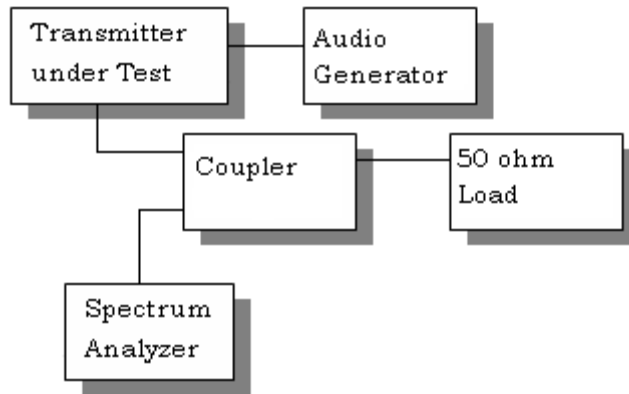

Test Data: See the plots below

12.5kHz: ANALOG

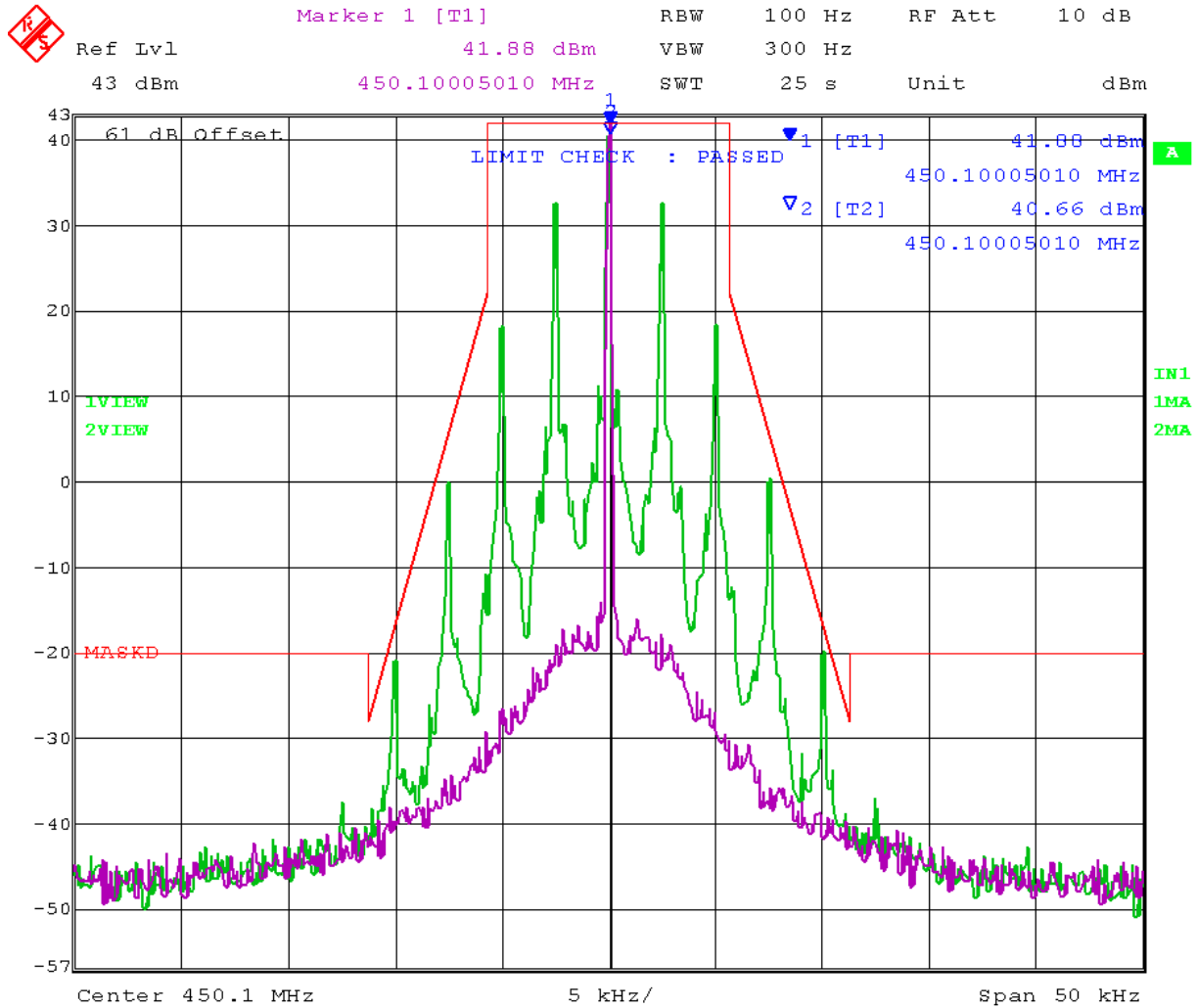

Date: 27.FEB.2013 14:02:19



Marker 1 [T1] RBW 100 Hz RF Att 10 dB
 Ref Lvl 41.81 dBm VBW 300 Hz
 43 dBm 481.10005010 MHz SWT 25 s Unit dBm

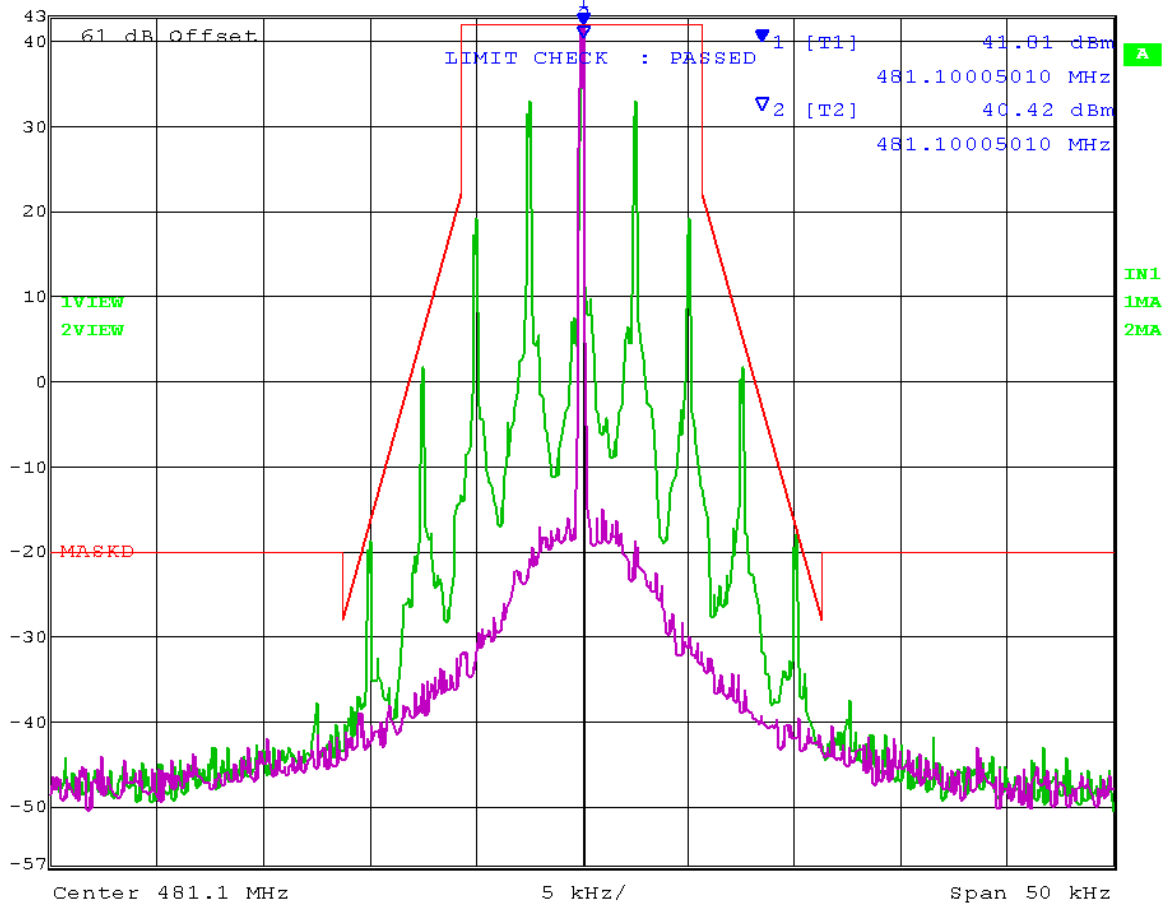

Date: 27.FEB.2013 11:05:14

Applicant: STANDARD COMMUNICATIONS Pty.Ltd.
 FCC ID: TXJCM1039U
 Report: s\STANDARD Comm Au\351AUT13\351AUT13TestReport.doc



Marker 1 [T1] RBW 100 Hz RF Att 10 dB
 Ref Lvl 42.21 dBm VBW 300 Hz
 43 dBm 511.90005010 MHz SWT 25 s Unit dBm

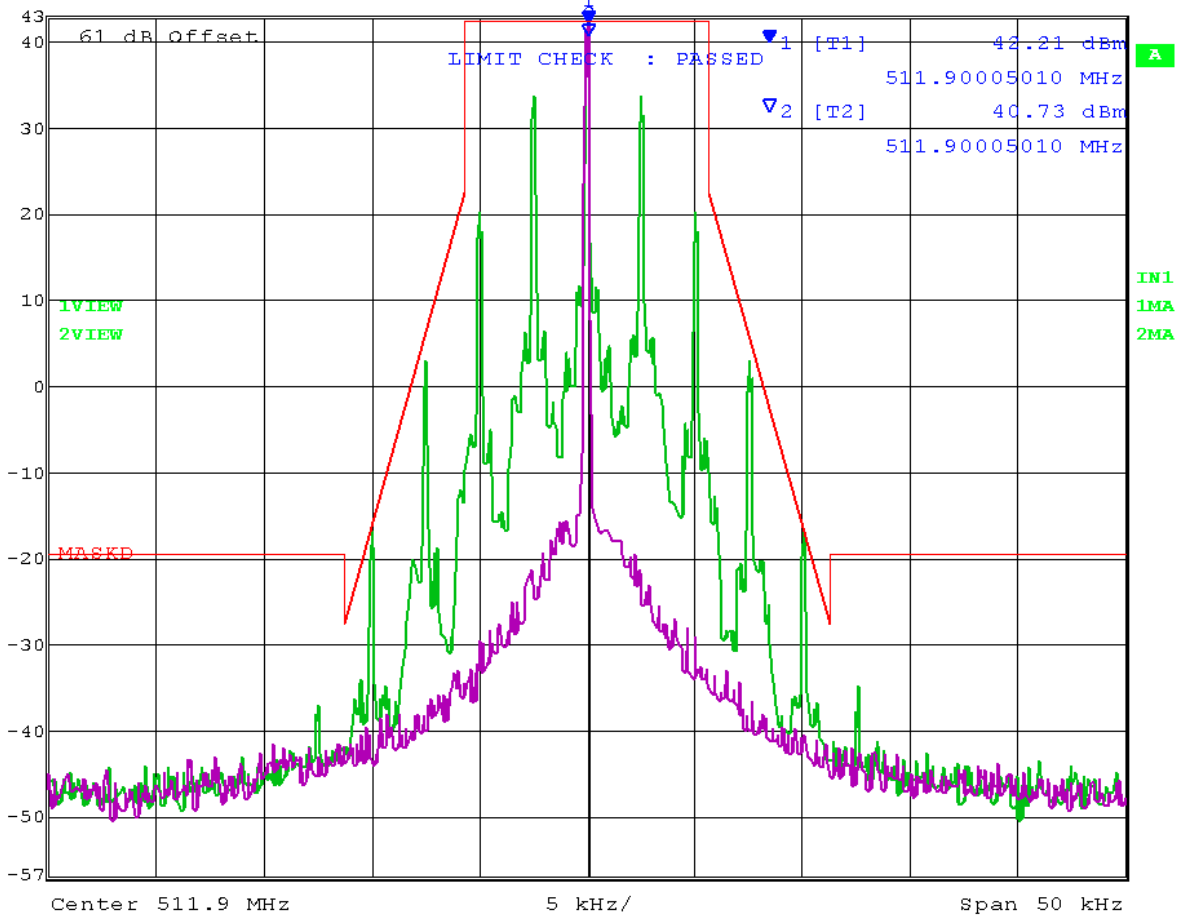

12.5kHz - DIGITAL

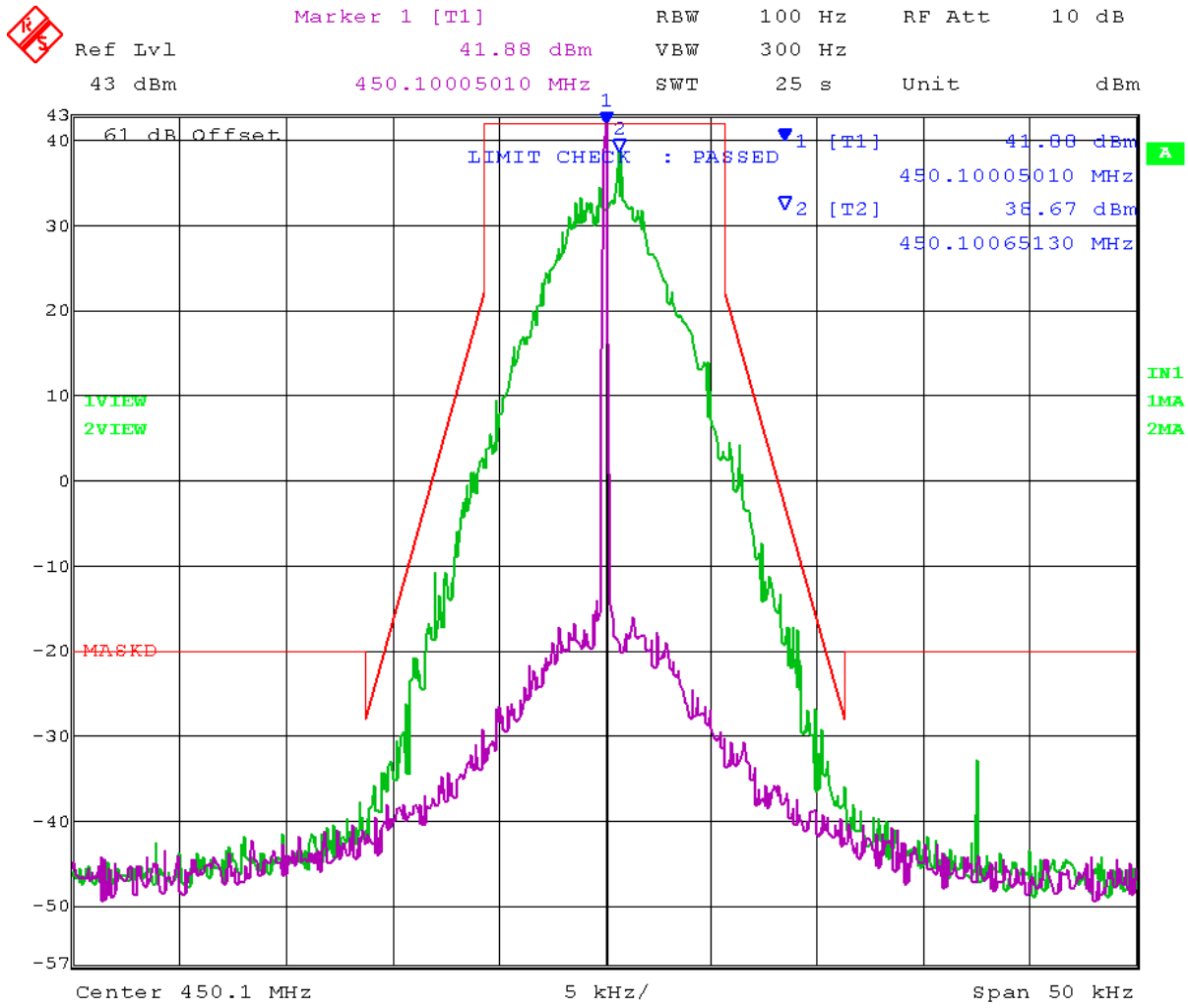

Date: 27.FEB.2013 14:06:15

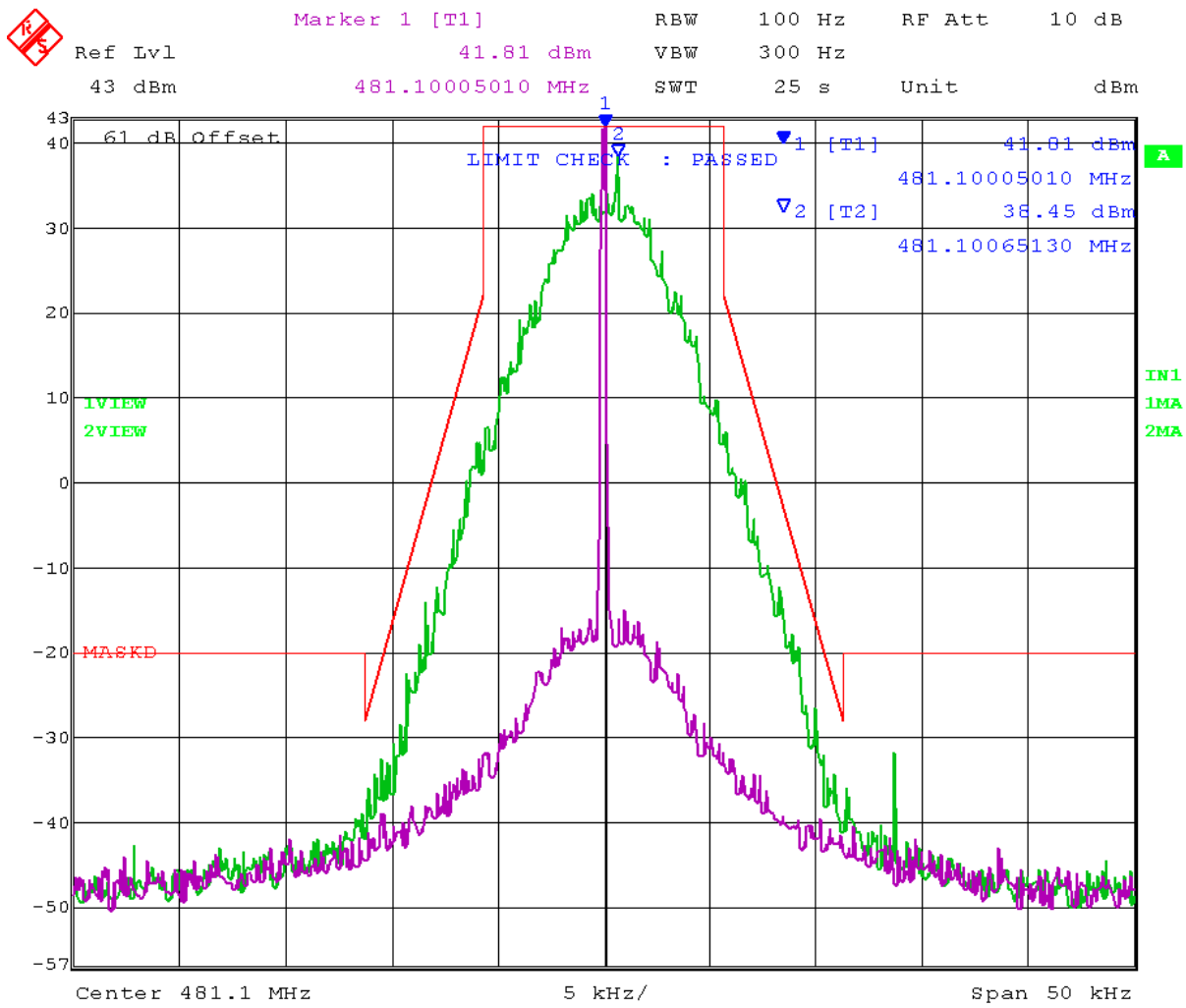

Date: 27.FEB.2013 11:10:58

Applicant: STANDARD COMMUNICATIONS Pty.Ltd.
 FCC ID: TXJCM1039U
 Report: s\STANDARD Comm Au\351AUT13\351AUT13TestReport.doc



Marker 1 [T1] RBW 100 Hz RF Att 10 dB
 Ref Lvl 42.21 dBm VBW 300 Hz
 43 dBm 511.90005010 MHz SWT 25 s Unit dBm

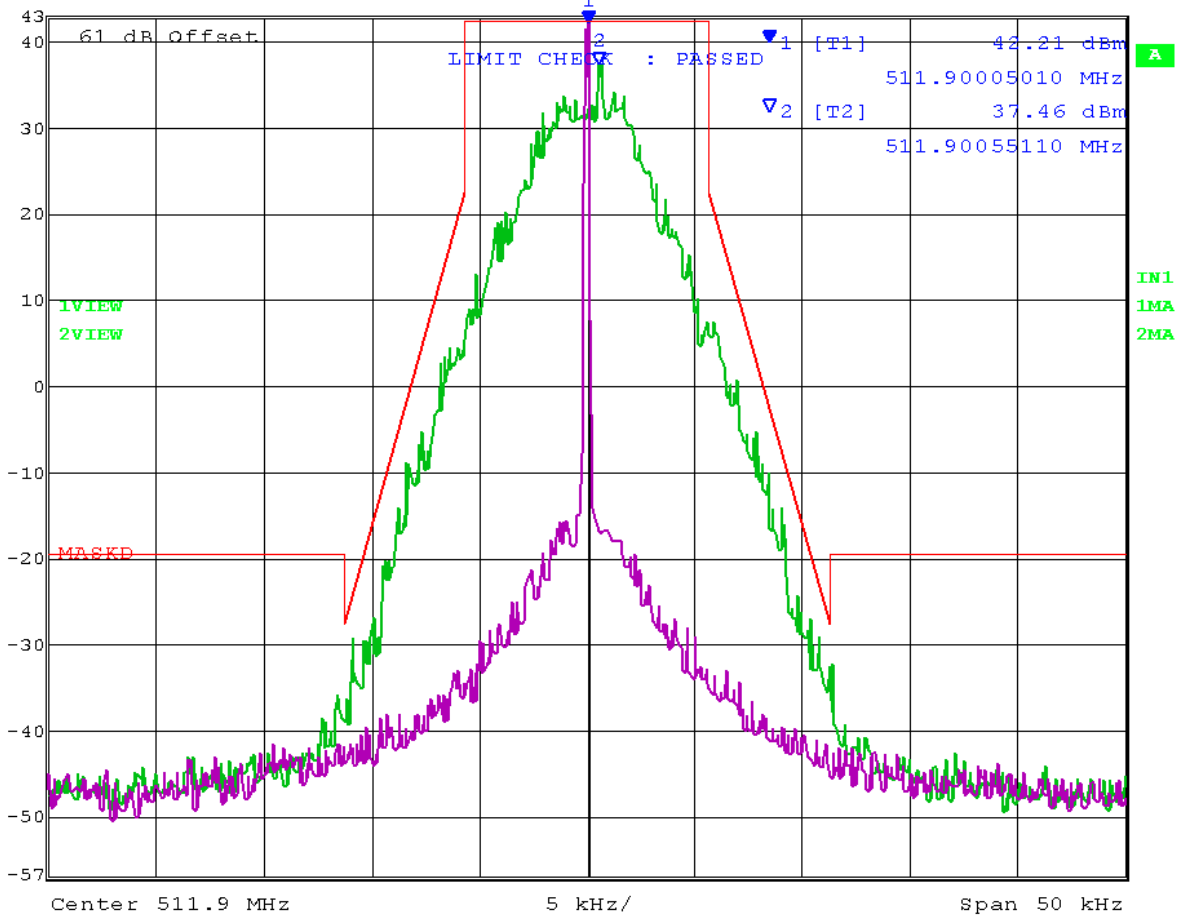

Date: 27.FEB.2013 14:47:21

SPURIOUS EMISSIONS AT ANTENNA TERMINALS (CONDUCTED)

Rule Part No.: FCC Part 2.1051(a), RSS-GEN 7.1.4

Requirements: 12.5 kHz Channel Spacing = 64 dBc (for 25 Watts)

Method of Measurement: The carrier was modulated 100% using a 2500 Hz tone. The spectrum was scanned from 0.4 to at least the 10th harmonic of the fundamental. The measurements were made in accordance with standard ANSI/TIA 603-C:2004.

Test Data:

TF HIGH POWER	EF	dB below carrier		TF LOW POWER	EF	dB below carrier
450.10	900.20	87.3		450.10	900.20	79.1
	1350.30	86.8			1350.30	86.9
	1800.40	90.2			1800.40	91.8
	2250.50	90.8			2250.50	90.7
	2700.60	94.9			2700.60	95
	3150.70	91.9			3150.70	92.5
	3600.80	97.3			3600.80	94.1
	4050.90	97.5			4050.90	94.7
	4501.00	97.8			4501.00	93.7

TF HIGH POWER	EF	dB below carrier		TF LOW POWER	EF	dB below carrier
481.1	962.20	102		481.1	962.20	93.1
	1443.30	80.5			1443.30	83.1
	1924.40	90.3			1924.40	78.7
	2405.50	86.6			2405.50	89.5
	2886.60	96.3			2886.60	93.9
	3367.70	98.4			3367.70	94.7
	3848.80	94.8			3848.80	94.3
	4329.90	97.5			4329.90	92.5
	4811.00	96.4			4811.00	94.4

TF HIGH POWER	EF	dB below carrier		TF LOW POWER	EF	dB below carrier
511.90	1023.80	93.3		511.90	1023.80	80.2
	1535.70	75.5			1535.70	78.3
	2047.60	86.5			2047.60	90
	2559.50	86.1			2559.50	90.6
	3071.40	86.7			3071.40	92
	3583.30	101.1			3583.30	95.3
	4095.20	103.6			4095.20	94.3
	4607.10	105.2			4607.10	93.6
	5119.00	105.5			5119.00	95

Method of Measuring Conducted Spurious Emissions

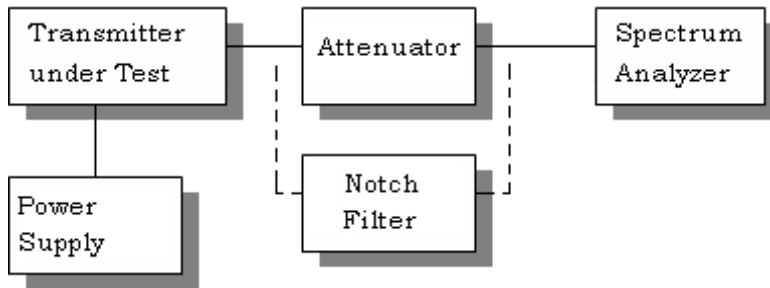

METHOD OF MEASUREMENT: The procedure used was ANSI/TIA 603-C: 2004. The measurements were made at TIMCO ENGINEERING INC. 849 N.W. State Road 45, Newberry, Florida 32669.

FIELD STRENGTH OF SPURIOUS EMISSIONS

Rule Parts. No.: FCC Part 2.1053, RSS-GEN 4.9

Requirements: The FCC limits for radiated emissions are the same as previously stated for the conducted emissions.

METHOD OF MEASUREMENT: The tabulated data shows the results of the radiated field strength emissions test. The spectrum was scanned from 30 MHz to at least the tenth harmonic of the fundamental. This test was conducted per ANSI/TIA 603-C: 2004 using the substitution method. Measurements were made at the test site of TIMCO ENGINEERING, INC. located at 849 NW State Road 45, Newberry, FL 32669.

Test Setup Diagram:

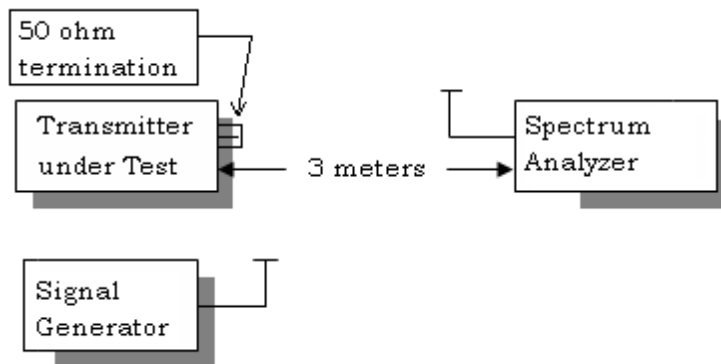

Test Data:

High Power

Emission Frequency MHz	Ant. Polarity	dB Below Carrier (dBc)
450.10	0	0
900.20	H	80.8
1350.30	H	77.5
1800.40	H	74.3
2250.50	H	75.7
2700.60	H	79.1
3150.70	H	87.8
3600.80	H	87.3
4050.90	H	89.4
4501.00	H	85.2

Low Power

Emission Frequency MHz	Ant. Polarity	dB Below Carrier (dBc)
450.10	0	0
900.20	H	71.5
1350.30	H	78.8
1800.40	H	66.4
2250.50	H	77.6
2700.60	H	82.0
3150.70	H	79.5
3600.80	H	78.6
4050.90	H/V	NE
4501.00	H/V	NE

High Power

Emission Frequency MHz	Ant. Polarity	dB Below Carrier (dBc)
481.10	0	0
962.20	H	91.4
1443.30	H	72.7
1924.40	H	71.7
2405.50	H	67.5
2886.60	H	74.1
3367.70	H	87.8
3848.80	H	73.4
4329.90	H	82.8
4811.00	H	79.2

Low Power

Emission Frequency MHz	Ant. Polarity	dB Below Carrier (dBc)
481.10	0	0
962.20	H	71.6
1443.30	H	68.3
1924.40	H	64.2
2405.50	H	77.0
2886.60	H	78.6
3367.70	H	79.5
3848.80	H	80.9
4329.90	H/V	NE
4811.00	H/V	NE

HIGH POWER

Emission Frequency MHz	Ant. Polarity	dB Below Carrier (dBc)
511.90	0	0
1023.80	H	85.8
1535.70	H	69.7
2047.60	H	67.8
2559.50	H	74.4
3071.40	H	78.6
3583.30	H	76.4
4095.20	H	79.2
4607.10	H	83.7
5119.00	H	87.8

LOW POWER

Emission Frequency MHz	Ant. Polarity	dB Below Carrier (dBc)
511.90	0	0
1023.80	H	70.8
1535.70	H	66.2
2047.60	H	66.5
2559.50	H	80.7
3071.40	H	74.4
3583.30	H/V	NE
4095.20	H/V	NE
4607.10	H/V	NE
5119.00	H/V	NE

FREQUENCY STABILITY

Rule Parts. No.: FCC Part 2.1055, Part 90.213, RSS-119 5.3, RSS-GEN 7.2.4

Requirements: Temperature range requirements: -30 to +50° C.
Voltage Variation +, -15%
±1.5 PPM

Method of Measurements: ANSI/TIA 603-C:2004

Test Data:

Assigned Frequency (Ref. Frequency) (MHz)		460.000037
Temperature (°C)	Frequency (MHz)	Frequency Stability (PPM)
-30	460.000286	0.54
-20	460.000055	0.04
-10	459.999921	-0.25
0	459.999804	-0.51
+10	459.999953	-0.18
+20	460.000008	-0.06
+30	459.999980	-0.12
+40	459.999976	-0.13
+50	459.999995	-0.09

Assigned Frequency (Ref. Frequency) (MHz)		
% Battery (%)	Frequency (MHz)	Frequency Stability (PPM)
-15%	460.000043	0.01
	460.000037	0
+15%	460.000034	-0.01

TRANSIENT FREQUENCY BEHAVIOR

FCC Part 2.1055(a)(1)

FCC Part 90.214, IC RSS-119 5.8

REQUIREMENTS: Transmitters designed to operate in the 150-174 MHz and 421-512 MHz frequency bands must maintain transient frequencies within the maximum transient frequencies within the maximum frequency difference limits during the time intervals indicated:

Time Intervals	Maximum frequency difference	All Equipment	
		150-174 MHz	421-512 MHz

Transient Frequency Behavior for Equipment Designed to Operate on 25 kHz Channels

Time Intervals	Maximum frequency difference	150-174 MHz	421-512 MHz
t ₁ ⁴	±25.0 kHz	5.0 ms	10.0 ms
t ₂	±12.5 kHz	20.0 ms	25.0 ms
t ₃ ⁴	±25.0 kHz	5.0 ms	10.0 ms

Transient Frequency Behavior for Equipment Designed to Operate on 12.5 kHz Channels

Time Intervals	Maximum frequency difference	150-174 MHz	421-512 MHz
t ₁ ⁴	±12.5 kHz	5.0 ms	10.0 ms
t ₂	±6.25 kHz	20.0 ms	25.0 ms
t ₃ ⁴	±12.5 kHz	5.0 ms	10.0 ms

Transient Frequency Behavior for Equipment Designed to Operate on 6.25 kHz Channels

Time Intervals	Maximum frequency difference	150-174 MHz	421-512 MHz
t ₁ ⁴	±6.25 kHz	5.0 ms	10.0 ms
t ₂	±3.125 kHz	20.0 ms	25.0 ms
t ₃ ⁴	±6.25 kHz	5.0 ms	10.0 ms

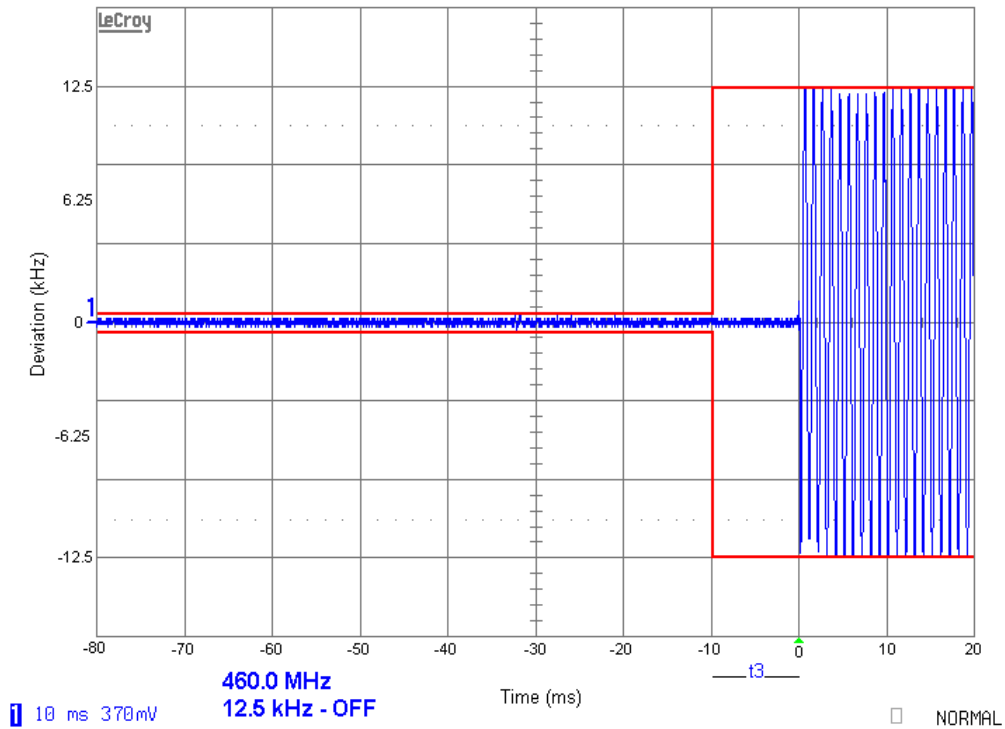
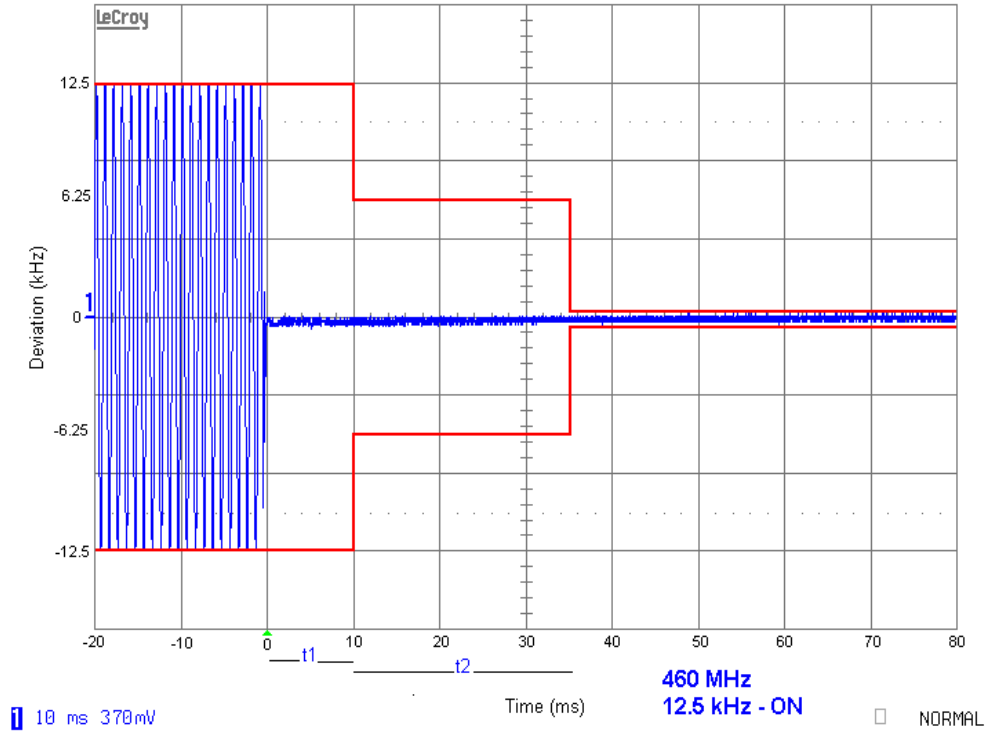

Applicant: STANDARD COMMUNICATIONS Pty.Ltd.
 FCC ID: TXJCM1039U
 Report: s\STANDARD Comm Au\351AUT13\351AUT13TestReport.doc

TEST PROCEDURE: ANSI/TIA 603-C:2004 PARA 2.2.19

1. Using the variable attenuator the transmitter level was set to 40 dB below the test receivers maximum input level, then the transmitter was turned off.
2. With the transmitter off the signal generator was set 20dB below the level of the transmitter in the above step, this level will be maintained with the signal generator through-out the test.
3. Reduce the attenuation between the transmitter and the RF detector by 30 dB. With the levels set as above the transient frequency behavior was observed & recorded.

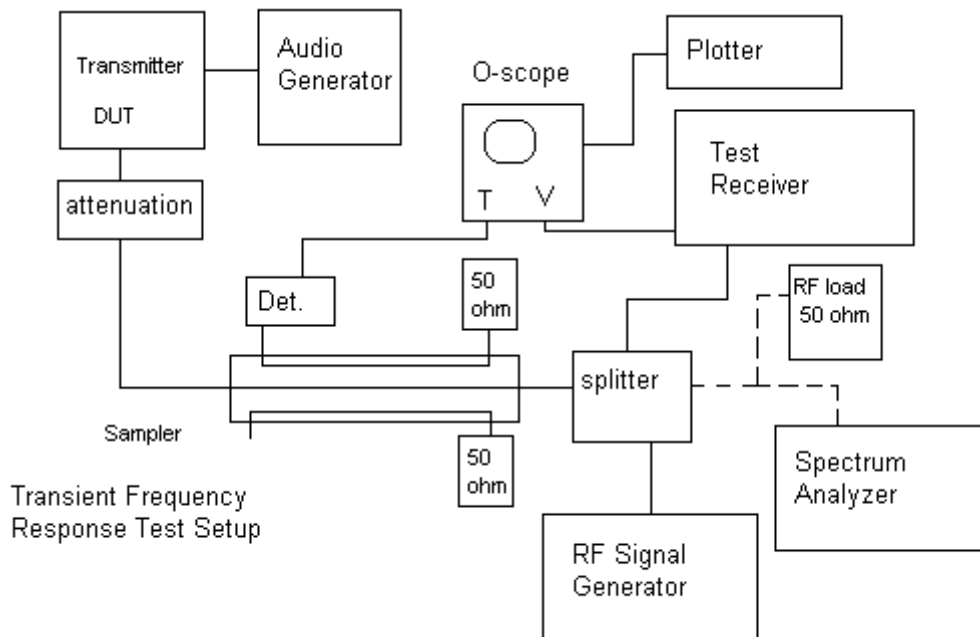

EMC EQUIPMENT LIST

Device	Manufacturer	Model	Serial Number	Cal/Char Date	Due Date
3-Meter Semi-Anechoic Chamber	Panashield	N/A	N/A	Listed 12/31/11	12/31/13
AC Voltmeter	HP	400FL	2213A14499	CAL 6/12/11	6/12/13
Frequency Counter	HP	5385A	2730A03025	CAL 8/17/11	8/17/13
Hygro-Thermometer	Extech	445703	0602	CAL 6/15/11	6/15/13
Modulation Analyzer	HP	8901A	3435A06868	CAL 7/18/11	7/18/13
Digital Multimeter	Fluke	FLUKE-77	35053830	CAL 9/9/11	9/9/13
Power Meter	Boonton Electronics	4531	11793	CAL 1/9/13	1/9/15
EMI Receiver	Rohde & Schwarz	ESIB40	100274	CAL 3/16/12	3/16/14
Analyzer Tan Tower Preamplifier	HP	8449B-H02	3008A00372	CAL 10/28/11	10/28/13
Analyzer Tan Tower Quasi-Peak Adapter	HP	85650A	3303A01690	CAL 10/28/11	10/28/13
Analyzer Tan Tower RF Preselector	HP	85685A	3221A01400	CAL 10/28/11	10/28/13
Analyzer Tan Tower Spectrum Analyzer	HP	8566B Opt 462	3138A07786 3144A20661	CAL 10/28/11	10/28/13
Temperature Chamber	Thermotron	S 1.2 Mini max	25-1420-0	CHAR 7/3/12	7/3/14
Power Meter	Bird	4421	0166	12/15/11	12/15/13
Oscilloscope	Lecroy	LT364L	00543	6/15/11	6/15/13
Horn Antenna	ETS	3117	35923	12/7/11	12/7/13
Antenna	Electro metrics	LPA-25	1122	5/04/11	5/04/13
Antenna	Electro metrics	BIA-25	1096	5/04/11	5/04/13

Applicant: STANDARD COMMUNICATIONS Pty.Ltd.
 FCC ID: TXJCM1039U
 Report: s\STANDARD Comm Au\351AUT13\351AUT13TestReport.doc