

Certification of Compliance

CFR 47 Part 15 Subpart B, Subpart C

Test Report File No. : 08-IST-0409 **Date of Issue** : June 23, 2008

Model(s) : RH55K00
Buyer Model(s) : RH55L, RFIRCONV, ZR100, ZR200
Kind of Product : RF IR Converter
FCC ID : TX4RH55K
Applicant : Remote Solution Co., Ltd.
Address : 92, Chogokri, Nammyun, Kimchon city, Kyungbuk, 740-871, Korea

Manufacturer : Remote Solution Co., Ltd.
Address : 92, Chogokri, Nammyun, Kimchon city, Kyungbuk, 740-871, Korea

Test Result

Positive

Negative

Reviewed By

Approved By



S.J.CHO / EMC Group Manager



B.S.KIM / Chief

Comment (s)

- Investigations requested : Measurement to the relevant clauses of FCC rules and regulations Part 15 Subpart B, Subpart C.
 - The test report with appendix consists of 45 pages.
 - The test result only responds to the tested sample.
 - It is not allowed to copy this report even partly without the allowance of IST EMC Laboratory.
 - This equipment as for has been shown to be capable of continued compliance with the applicable technical standards as indicated in the measurement report and was tested in accordance with the measurement procedures specified in ANSI C63.4
- I assume full responsibility for accuracy and completeness of these data.



TABLE OF CONTENTS

Table of contents	2
Information of test laboratory, Environmental conditions, Power used, Product information	3
Descriptions of Test	4
- Conducted Emission	4
-Conducted Emission Limits	5
- Radiated Emission	6
-Radiated Emission Limits	7
Measurement Uncertainty Calculations	8
Equipment Under Test	9
- Summary	10
- Conducted Emission	11
-Conducted Emission Result	12-13
- Radiated Emission	14
- Radiated Emission Result	15-28
- Peak power output	29
- Test Equipment & Limits	29
-Test result	30
- Band edge	31
- Test Equipment & Limits	31-32
- Test result	33
- 6dB Band	38
- Test Equipment & Limits	38
- Test Result	39
- Power Density	40
- Test Equipment & Limits	40
- Test Result	41
- Test Photo of Test Setup	42-44
- The Photos of Equipment Under Test	45

Note:

INFORMATIONS OF TEST LABORATORY

EMC LABORATORY of IST Co., Ltd. (*FCC Filing Lab-400603.*)

Singal-dong, Giheung-gu, Yongin-City

Kyonggi-Do, 400-19, Korea

TEL : +82 31 326 6700

FAX : +82 31 326 6797

ENVIRONMENTAL CONDITIONS

Temperature 23 °C Humidity 44 %

Atmospheric pressure 1012 mbar

POWER SUPPLY SYSTEM USED

Power supply system AC 120V(Adaptor)

(Refer to the product information)

PRODUCT INFORMATION

Item	Specification
RF Frequency Range	2400 MHz ~ 2483.5 MHz
Use Distance	IR Blaster : 1 m
	IR Flashers : 5 cm
RS232	RF : 20 meters (Depending on operation condition, distance can be changed)
	Speed : 2,400 ~ 115,200 bps
	Interface : Tx, Rx and GND
Operating temperature	Cable Adapter : male DB9 to Stereo Plug (Need to purchase a converter for PC firmware upgrade)
Humidity	0 °C ~ + 35 °C
Power	0 ~ 90 %
	Input : AC 100~240V ~ 50/60 Hz, 0.35A
Dimension	Output : DC 12 V, 1.0A
	130(W)*100(H)*27(D)mm

- Regards to the frequency band operation; the highest that was included the lowest, middle and highest frequency of channel were selected to perform the test, and then shown on this report.

- Please refer to user's manual.

DESCRIPTION OF TEST

Conducted Emissions:

The measurement were performed over the frequency range of 0.15 MHz to 30 MHz using a 50 Ω/50 uH LISN as the input transducer to a Spectrum Analyzer or a Field Intensity Meter. The measurements were made with the detector set for "Peak" amplitude within a bandwidth of 10KHz or for "quasi-peak" & "Average" within a bandwidth of 9 KHz.

-Procedure of Test

The line-conducted facility is located inside a shielded room No.1. A 1 m X 1.5 m wooden table 80 cm height is placed 40 cm away from the vertical wall and 1.5 m away from the other wall of the shielded room. The R/S ESCI and Hyup-Rip KNW-407 LISN are bonded to bottom of the shielded room. The EUT is located on the wooden table with distance more than 80 cm from the LISN and powered from the EMCO LISN .The peripheral equipment is powered from the other LISN. Power to the LISNs are filtered by a noise cut power line filters. All electrical cables are shielded by braided tinned steel tubing with inner φ 1.2 cm. If the EUT is a DC-powered device, power will be derived from the source power supply it normally will be powered from and this supply lines will be connected to the EMCO LISN. All interconnecting cables more than 1m were shortened by non-inductive bundling to a 1m length. Sufficient time for the EUT, support equipment, and test equipment was allowed in order for them to warm up to their normal operating conditions. The RF output of the LISN was connected to the R/S receiver to determine the frequency producing the maximum emission from the EUT. The frequency producing the maximum level was reexamined using Quasi-Peak mode by manual measurement, after scanned by automatic Peak mode for frequency range from 0.15 to 30 MHz. The bandwidth of the receiver was set to 10 kHz. The EUT, peripheral equipment, and interconnecting cables were arranged and manipulated to maximize each EME emission.

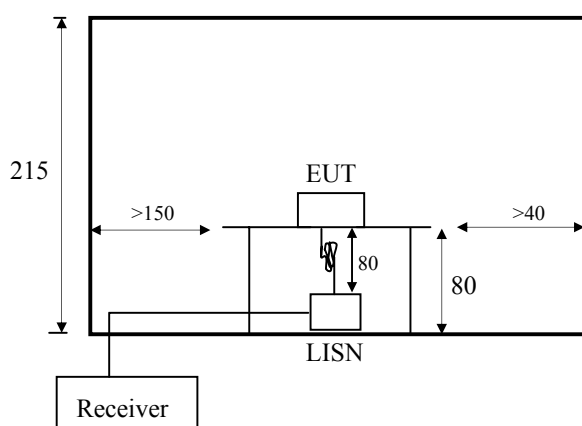

< Side View >

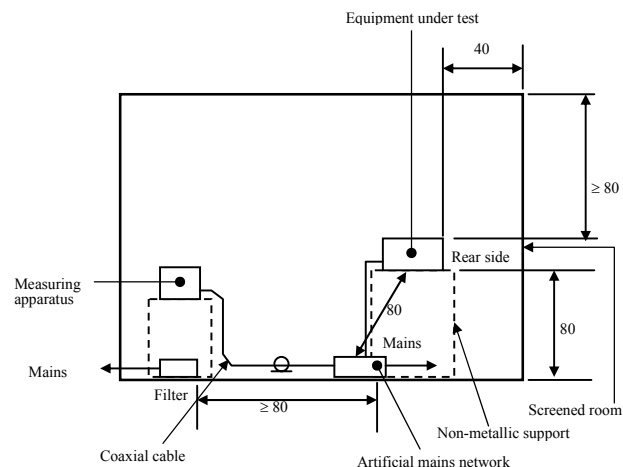

< Concept Drawing >

Limits

According to § 15.107(a), 15.207(a) except as shown in paragraphs (b) and (c) of this section, for an intentional radiator that is designed to be connected to the public utility (AC) power line, the radio frequency voltage that is conducted back onto the AC power line on any frequency or frequencies within the band 150 kHz to 30 MHz shall not exceed the limits in the following table, as measured using a 50 μH/50 ohms line impedance stabilization network(LISN). Compliance with the provisions of this paragraph shall be based on the measurement of the radio frequency voltage between each power line and ground at the power terminal. The lower limit applies at the boundary between the frequency ranges.

Frequency Range (MHz)	Limits	
	Quasi-peak	Average
0.15 to 0.50	66 to 56*	56 to 46*
0.50 to 5	56	46
5 to 30	60	50

* Decreases with the logarithm of the frequency.

Test specification.

According to FCC CFR Title 47 Part 15 Subpart B Section 15.107

FCC CFR Title 47 Part 15 Subpart C Section 15.207 : 2005

Radiated Emissions:

The measurement was performed over the frequency range of 30MHz to 1GHz using antenna as the input transducer to a Spectrum analyzer or a Field Intensity Meter. The measurement was made with the detector set for "quasi-peak" within a bandwidth of 120kHz. Procedure of Test

Preliminary measurements were made at 3 meter using bi-log antennas, and spectrum analyzer to determine the frequency producing the max. emission in anechoic chamber. Appropriate precaution was taken to ensure that all emission from the EUT were maximized and investigated. The system configuration, mode of operation, turn-table azimuth and height with respect to the antenna were noted for each frequency found. The spectrum was scanned from 30MHz to 1000MHz using bi-log antenna. Above 1GHz, linearly polarized double ridge horn antennas were used. Final measurements were made at open site with 3-meters test distance using bi-log antenna or horn antenna. The OATS have been verified in regular for its normalized site attenuation. The test equipment was placed on a wooden table. Sufficient time for the EUT, peripheral equipment, and test equipment was allowed in order for them to warm up to their normal operating condition. Each frequency found during pre-scan measurements was re-examined by manual. The detector function was set to CISPR quasi-peak mode and the bandwidth of the receiver was set to 120kHz or 1MHz depending on the frequency of type of signal. The EUT, peripheral equipment and interconnecting cables were re-configured to the set-up producing the max. emission for the frequency and were placed on top of a 0.8-meter high nonmetallic 1 x 1.5 meter table. The EUT, peripheral equipment, and interconnecting cables were re-arranged and manipulated to maximize each emission. The turntable containing the system was rotated; the antenna height was varied 1 to 4 meters and stopped at the azimuth or height producing the maximum emission. Each emission was maximized by: varying the mode of operation to the EUT and/or peripheral equipment and changing the polarity of the antenna, whichever determined the worst-case emission. (The bandwidth below 1GHz setting on the field strength meter is 120KHz and above 1GHz is 1MHz.)

Under 1GHz Test Setup:

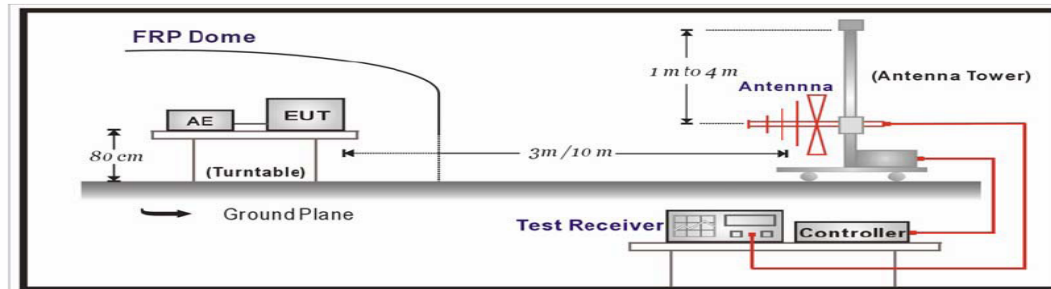

Above 1GHz Test Setup:

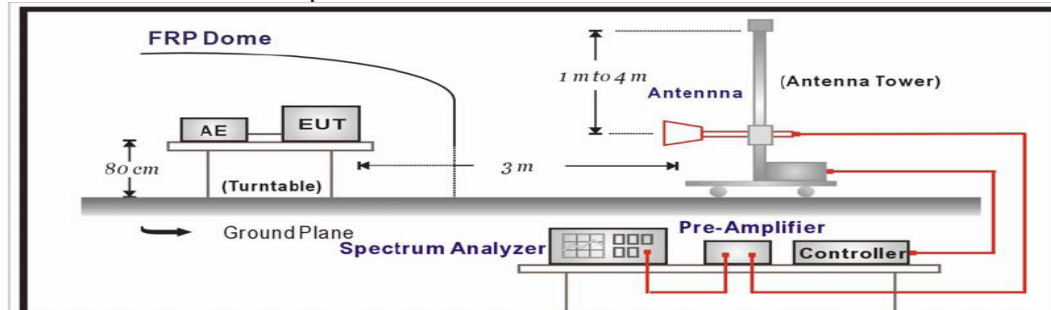

Limits

Emissions radiated outside of the specified frequency bands, except for harmonics, Shall be attenuated by at least 20dB below the level of the fundamental or to the General radiated emission limits in paragraph 15.109, 15.209, whichever is the lesser attenuation:

FCC Part 15 Subpart C Section 15.209 Limits		
Frequency (MHz)	μV/meter	dBμV/meter
30-88	100	40
88-216	150	43.5
216-960	200	46
Above 960	500	54

Remarks :

1. RF Voltage(dBuv)=20log RF Voltage(uV)
2. In the Above Table, the tighter limit applies at the band edges.
3. Distance refers to the distance in meters between the measuring Instrument antenna and the closed point of any part of the device or System.

Test specification.

According to FCC CFR Title 47 Part 15 Subpart B Section 15.109,
 FCC CFR Title 47 Part 15 Subpart C Section 15.209 : 2005

Measurement Uncertainty Calculations

The measurement uncertainties stated were calculated in accordance with the requirements of NIST Technical Note 1297 and NIS 81 (1994).

Contribution (Conducted Emissions)	Probability Distribution	Uncertainty (\pm dB)
		0.15-30MHz
Receiver Specification	Rectangular	1.5
LISN Coupling Specification	Rectangular	1.5
Cable and Input Attenuator Calibration	Normal (k=2)	0.5
Mismatch to Reciver	U-Shaped	-0.8 / +0.7
System Repeatability	Normal (k=1)	0.2
Combined Standard Uncertainty	Normal (k=2)	-1.85 / +1.71
Expanded Uncertainty U	Normal (k=2)	-3.7 / +3.42

$$U_{c,minus} = -1.85, U_{c,plus} = 1.71$$

$$U = -3.70 / +3.42 \text{ (k=2, 95.45\% confidence level)}$$

Contribution (Radiated Emissions)	Probability Distribution	Uncertainties(\pm dB)
		3 m
Antenna		
Factor	Normal (k=2)	0.9968
Frequency Interpolation	Rectangular	0.1039
Height Variation	Rectangular	-2.6 / +1.5
Directivity Difference	Rectangular	-1.0 / +0
Phase Center Location	Rectangular	1.0
Cable Loss	Normal (k=2)	0.5
Receiver		
Voltage Accuracy	Normal (k=2)	2.0
Pulse Response	Rectangular	1.5
Absolute Repetition Rate	Rectangular	1.5
Mismatch to Receiver		
$ \Gamma_{\text{antenna}} = 0.33$	U-Shaped	-1.0 / +0.9
$ \Gamma_{\text{receiver}} = 0.33$		
System Repeatability	Std Deviation	0.5
Combined Standard Uncertainty	Normal	-2.6048 / 2.2775
Expanded Uncertainty U	Normal (k=2)	-5.21 / +4.55

$$U_{c,minus} = -2.6048, U_{c,plus} = 2.2775$$

$$U = -5.21 / +4.55 \text{ (k=2, 95.45\% confidence level)}$$

Equipment Under Test

EUT Type :

- Table-Top. Floor-Standing.
- Table-Top and Floor-Standing(Combination).

Operation – mode of the E.U.T. :

The equipment under test was operated during the measurement under following conditions :

- Standby Mode
- Operational Condition : Continue Transmit, Serial Communication

Configuration of the equipment under test :

Following peripheral devices and interface cables were connected during the measurement :

Equipment	Type	Brand	Serial No.
PC	dx-6120MT	H.P.	CNG5210N2R
LCD Monitor	1707FPt	Dell Inc.	N/A
Keyboard(USB)	SK-2885	H.P.	B94750ACPSA7VE
Mouse(PS/2)	M-S48a	LZB11709821	H.P.
Adapter	HK-CH06-A12	HON-KWANG	N/A

Connecting Interface Cables :

- Unshielded AC power cable(without ferrite core) : 1.8 m
- Unshielded DC power cable(with one ferrite core) : 1.8 m
- Shielded D-sub signal cable (with two ferrite core) : 1.8 m
- Unshielded Serial cable (without ferrite core) : 1.9 m
- Unshielded IR cable(without ferrite core) : 2.9 m

Test Set-Up Configuration

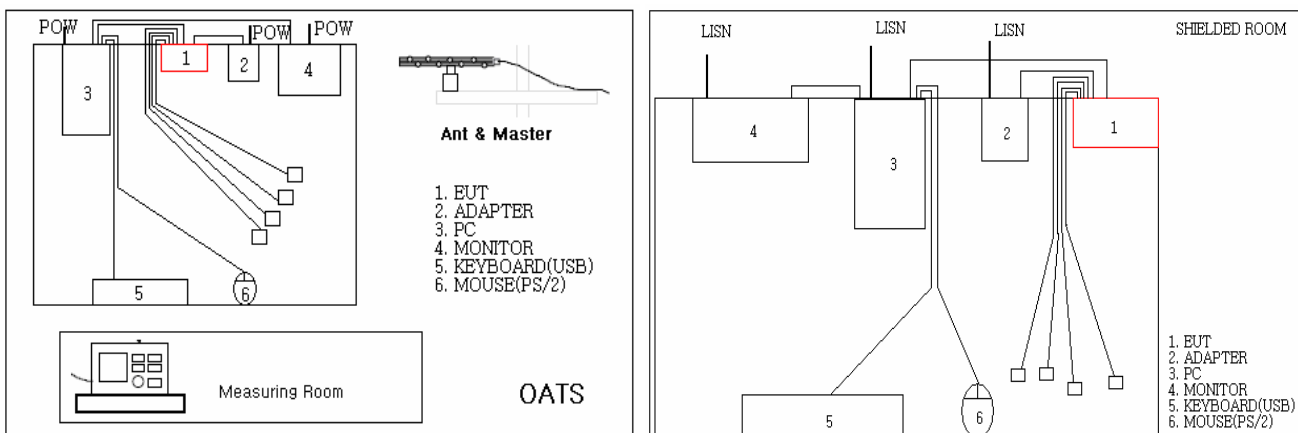

Radiated/Conducted Emissions

SUMMARY

Test Descriptions

- Conducted Emission	PASS
-Conducted Emission result	
- Radiated Emission	PASS
- Radiated Emission Result	
- Peak power output	PASS
- Test result	
- Band edge	PASS
- Test result	
- 6dB Band(Occupied Bandwidth)	PASS
- Test Result	
- Power Density	PASS
- Test Result	

Test Date

Begin of Testing : May 06, 2008 - End of Testing : June 09, 2008

Note :

- means the test is applicable,
- is not applicable.

Prepared By



J.Y. Choi / Senior Engineer

Conducted Emissions

[Applicable]

◆ Test Equipment Used

Model Name	Description	Manufacturer	Calibration Date	Serial No.
ESCI	Test Receiver	Rohde & Schwarz	Jun. 26, 2007	100373
ESH3-Z5	LISN	Rohde & Schwarz	Jul. 21, 2007	862770/025
ESH3-Z2	Pulse Limiter	Rohde & Schwarz	May. 21, 2008	357.8810.52

◆ Test Accessories Used

Type	Manufacturer
Aneroid Barometer	Sato
Hygrometer	Sato

◆ Test Program Continue Transmit, Serial Communication

◆ Test Date May 01, 2008

◆ Test Area Conducted Room No.2

Note : *The equipment used is calibrated in regular for every year.*

Conducted Emissions Result

Phase : Live

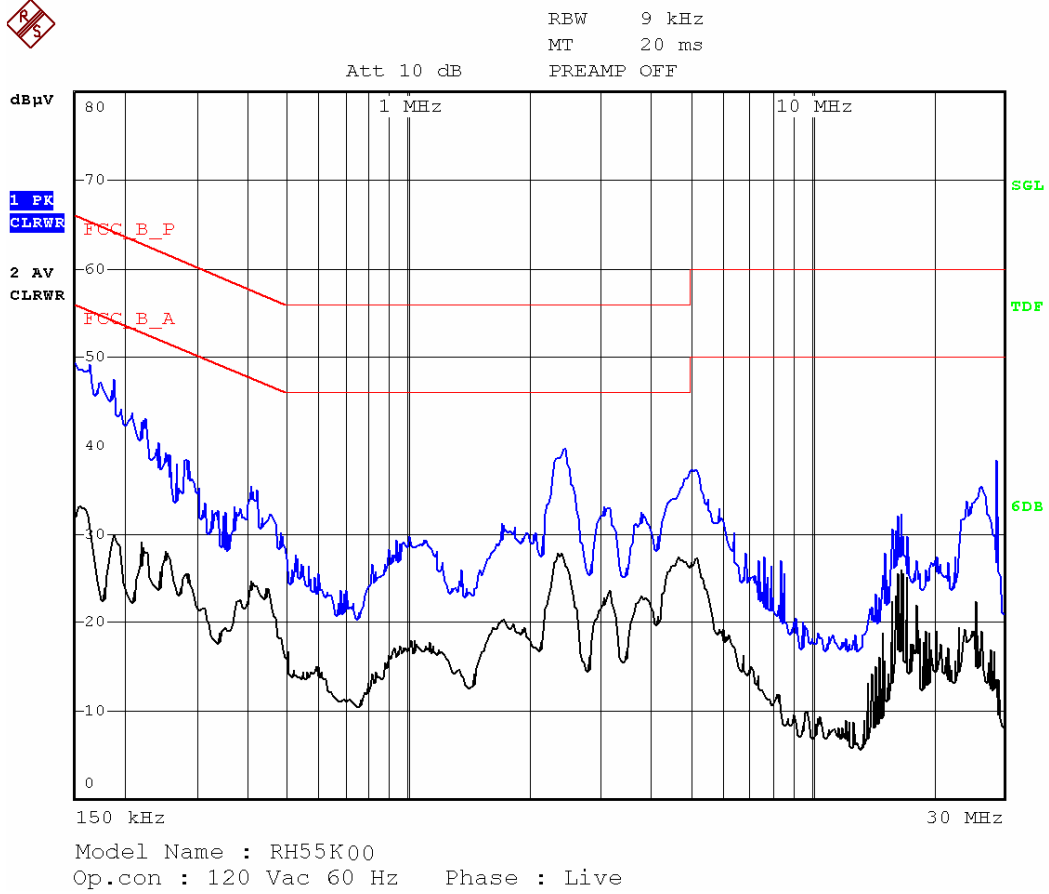

Freq. [MHz]	Measurement [dB µV]		Limit [dB µV]		Insertion Loss [dB]	Cable Loss [dB µV]	Result [dB µV]		Margin [dB]	
	Q-peak	Average	Q-peak	Average			Q-peak	Average	Q-peak	Average
0.15	46.61	30.85	66.00	56.00	0.06	0.25	46.92	31.16	19.08	24.84
0.18	41.78	28.44	64.72	54.72	0.06	0.25	42.09	28.75	22.63	25.97
0.22	37.22	25.55	62.74	52.74	0.07	0.29	37.58	25.91	25.16	26.83
2.41	35.22	26.89	56.00	46.00	0.14	0.39	35.75	27.42	20.25	18.58
4.98	31.01	26.65	56.00	46.00	0.21	0.44	31.66	27.30	24.34	18.70
26.35	24.28	18.51	60.00	50.00	1.38	0.61	26.27	20.50	33.73	29.50

Note : Continue Transmit and Serial Communication Mode

Conducted Emissions Result

Phase : Neutral



RBW 9 kHz
MT 20 ms
PREAMP OFF

Att 10 dB

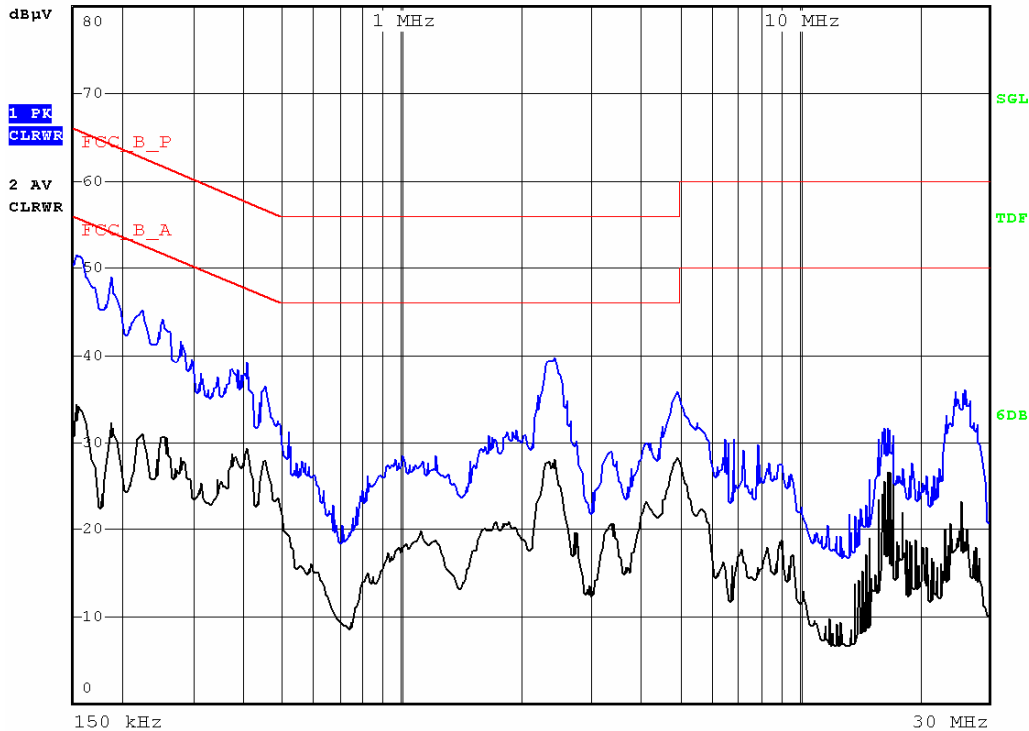

Model Name : RH55K00
Op.con : 120 Vac 60 Hz Phase : Neutral

Freq. [MHz]	Measurement [dB µV]		Limit [dB µV]		Insertion Loss [dB]	Cable Loss [dB µV]	Result [dB µV]		Margin [dB]	
	Q-peak	Average	Q-peak	Average			Q-peak	Average	Q-peak	Average
0.15	47.05	31.44	66.00	56.00	0.06	0.25	47.36	31.75	18.64	24.25
0.18	43.03	29.12	64.72	54.72	0.06	0.25	43.34	29.43	21.38	25.29
0.22	37.65	30.72	62.74	52.74	0.07	0.29	38.01	31.08	24.73	21.66
2.41	35.28	27.01	56.00	46.00	0.14	0.39	35.81	27.54	20.19	18.46
4.98	32.35	26.94	56.00	46.00	0.21	0.44	33.00	27.59	23.00	18.41
26.35	25.14	19.41	60.00	50.00	1.38	0.61	27.13	21.40	32.87	28.60

Note : Continue Transmit and Serial Communication Mode

Radiated Emission

[Applicable]

◆ Test Equipment Used

Name	Type	Manufacturer	Calibration. Date	Serial Number
ESCS30	EMI Receiver	Rohde & Schwarz	Aug. 10, 2007	100373
SPECTRUM ANALYZER	R3273	ADVANTEST	Oct. 01, 2007	MY420000092
BICONILOG Antenna	VULB 9160	Schwarz beck	Aug. 28, 2007	3047
HORN-Antenna	3115	EMCO	Dec. 26, 2007	9012-3602
HORN-Antenna	SAS-571	A.H. SYSTEMS	Dec. 26, 2007	500
PRE AMPLIFIER	8449B OPT H02	Rohde & Schwarz	Oct. 17, 2007	3008A0530

Note : 1. The calibration interval of the above test instruments is 12 months and the calibrations are traceable to RRL, KRISS, KTL and HCT.

2. The calibration interval of horn ant. and loop ant. is 24 months

Field Strength Calculation

The field strength is calculated by adding the Antenna Factor and Cable Factor, and subtracting the Amplifier Gain (if any) from the measured reading. For the limit is employed average value, therefore the peak value can be transferred to average value by subtracting the duty factor. The basic equation with a sample calculation is as follows:

$$Peak = Reading + Corrected Factor$$

Where

Corr. Factor = Antenna Factor + Cable Factor - Amplifier Gain (if any)

Radiated Emission Result

[Applicable]

EUT	RH55K00	PROBE	0.3GHz~1GHz-HOR
POWER	AC 120 V	NOTE	Serial Communication

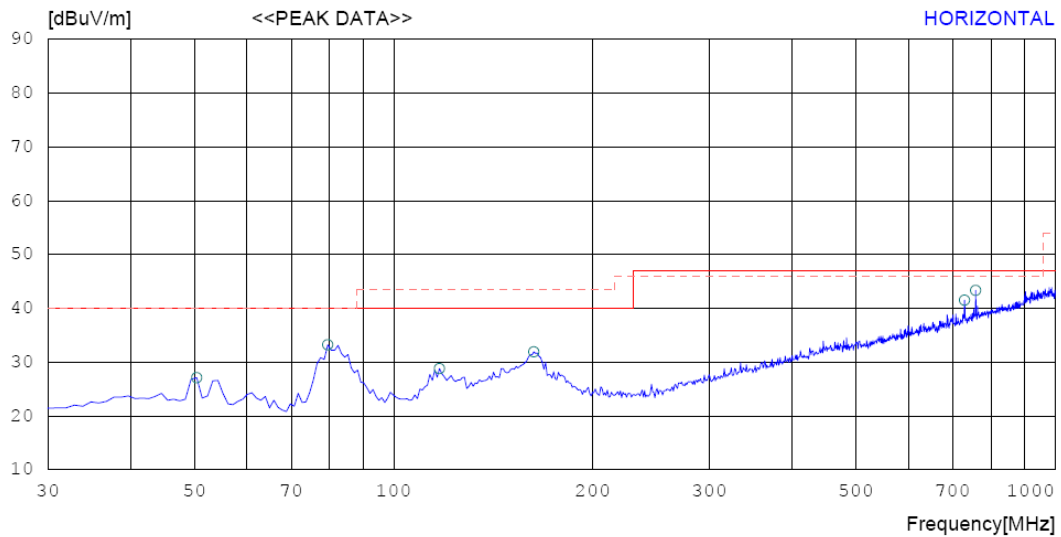

Frequency MHz	Reading dBuV	P (H, V)	Ant. Factor dB	Cable Loss dB	AMP GAIN dB	Limit dBuV	Total dBuV	Margin dB
50.37	14.30	H	11.22	0.81	0.0	40.00	26.33	-13.67
79.47	24.70	H	7.76	1.46	0.0	40.00	33.92	-6.08
117.30	15.10	H	11.32	1.89	0.0	43.50	28.31	-15.19
162.89	10.40	H	16.80	1.91	0.0	43.50	29.11	-14.39
729.36	15.20	H	21.05	5.45	0.0	46.00	41.70	-4.30
*758.46	16.40	H	21.02	4.82	0.0	46.00	42.24	-3.76

Note :

1. Remark "*" means that the data is the worst emission level.
2. All reading levels are Quasi-peak value.
3. Measurement level = reading level + correct factor

[Applicable]

EUT	RH55K00	PROBE	0.3GHz~1GHz-VER
POWER	AC 120 V	NOTE	Serial Communication

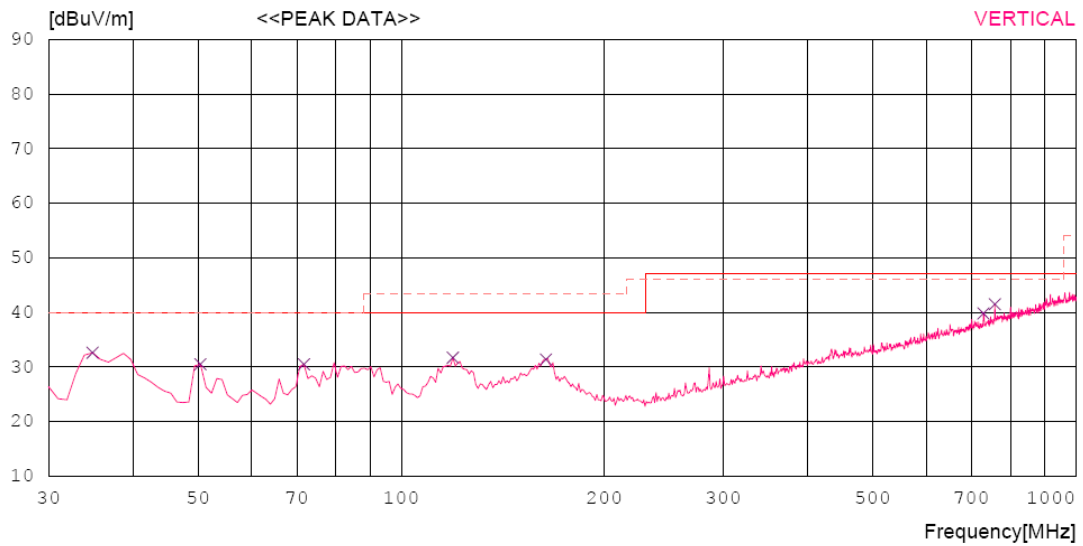

Frequency MHz	Reading dBuV	P (H, V)	Ant. Factor dB	Cable Loss dB	AMP GAIN dB	Limit dBuV	Total dBuV	Margin dB
34.85	20.60	V	11.25	0.97	0.0	40.00	32.82	-7.18
50.37	17.70	V	11.22	0.81	0.0	40.00	29.73	-10.27
71.71	21.30	V	8.03	1.00	0.0	40.00	30.33	-9.67
119.24	18.00	V	11.38	1.96	0.0	43.50	31.34	-12.16
163.86	9.70	V	16.47	1.95	0.0	43.50	28.12	-15.38
729.36	13.50	V	21.05	5.45	0.0	46.00	40.00	-6.00
*758.44	14.60	V	21.02	4.82	0.0	46.00	40.44	-5.56

Note :

1. Remark "*" means that the data is the worst emission level.
2. All reading levels are Quasi-peak value.
3. Measurement level = reading level + correct factor

[Applicable]

EUT	RH55K00	PROBE	0.3GHz~1GHz-HOR
POWER	AC 120 V	NOTE	TX-CH1 (2405 MHz)

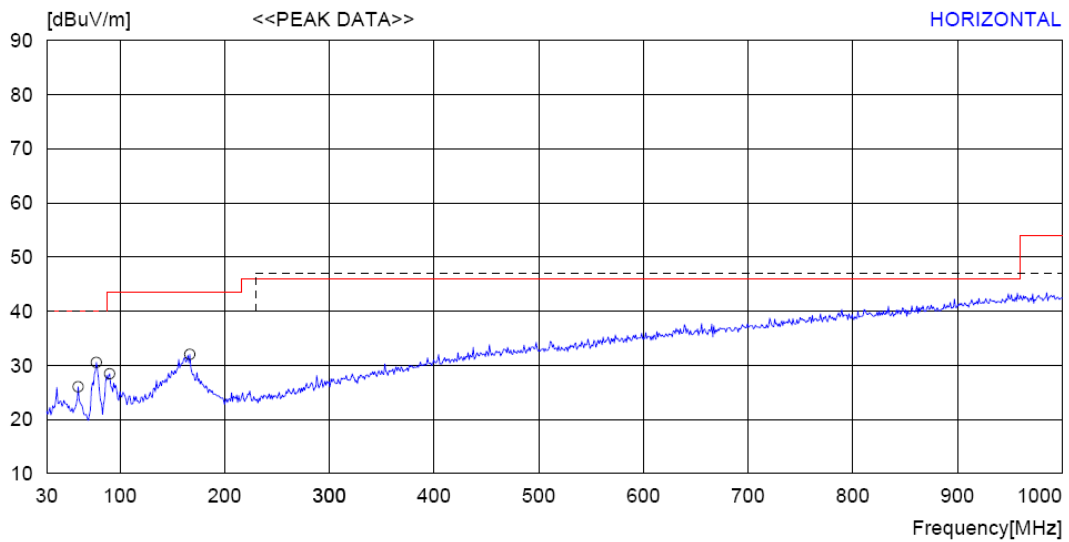

Frequency MHz	Reading dBuV	P (H, V)	Ant. Factor dB	Cable Loss dB	AMP GAIN dB	Limit dBuV	Total dBuV	Margin dB
60.07	11.80	H	12.43	0.80	0.0	40.00	25.03	-14.97
*77.53	22.00	H	7.83	1.35	0.0	40.00	31.18	-8.82
90.14	16.70	H	9.71	1.11	0.0	43.50	27.52	-15.98
166.77	11.30	H	15.45	2.07	0.0	43.50	28.82	-14.68

Note :

1. Remark "*" means that the data is the worst emission level.
2. All reading levels are Quasi-peak value.
3. Measurement level = reading level + correct factor

[Applicable]

EUT	RH55K00	PROBE	0.3GHz~1GHz-VER
POWER	AC 120 V	NOTE	TX-CH1 (2405 MHz)

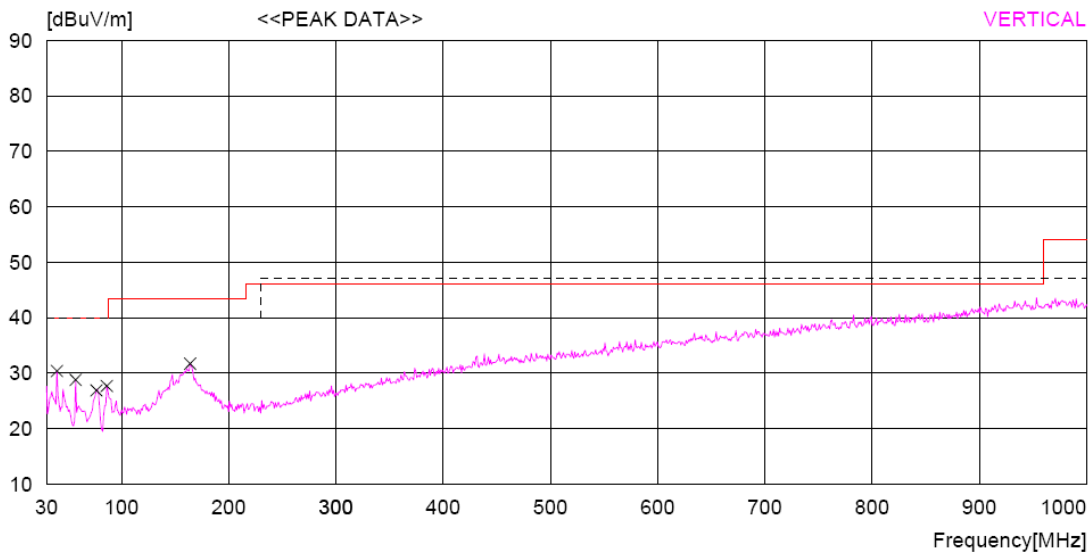

Frequency MHz	Reading dBuV	P (H, V)	Ant. Factor dB	Cable Loss dB	AMP GAIN dB	Limit dBuV	Total dBuV	Margin dB
*39.70	17.30	V	11.53	1.07	0.0	40.00	29.90	-10.10
57.16	16.20	V	11.09	1.15	0.0	40.00	28.44	-11.56
76.65	18.60	V	7.86	1.29	0.0	40.00	27.75	-12.25
86.26	17.20	V	7.50	1.50	0.0	40.00	26.20	-13.80
163.86	10.00	V	16.47	1.95	0.0	43.50	28.42	-15.08

Note :

1. Remark "*" means that the data is the worst emission level.
2. All reading levels are Quasi-peak value.
3. Measurement level = reading level + correct factor

[Applicable]

EUT	RH55K00	PROBE	0.3GHz~1GHz-HOR
POWER	AC 120 V	NOTE	TX-CH8 (2445 MHz)

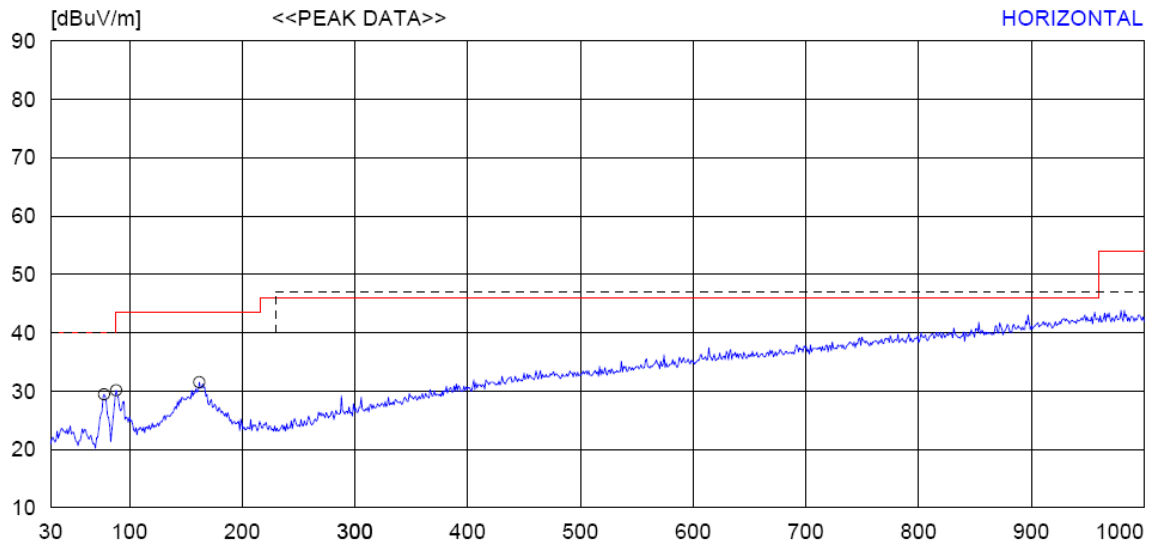

Frequency MHz	Reading dBuV	P (H, V)	Ant. Factor dB	Cable Loss dB	AMP GAIN dB	Limit dBuV	Total dBuV	Margin dB
*77.53	20.90	H	7.83	1.35	0.0	40.00	30.08	-9.92
88.20	18.90	H	7.76	1.65	0.0	43.50	28.31	-15.19
161.92	10.20	H	17.14	1.87	0.0	43.50	29.21	-14.29

Note :

1. Remark "*" means that the data is the worst emission level.
2. All reading levels are *Quasi-peak* value.
3. *Measurement level* = reading level + correct factor

[Applicable]

EUT	RH55K00	PROBE	0.3GHz~1GHz-VER
POWER	AC 120 V	NOTE	TX-CH8 (2445 MHz)

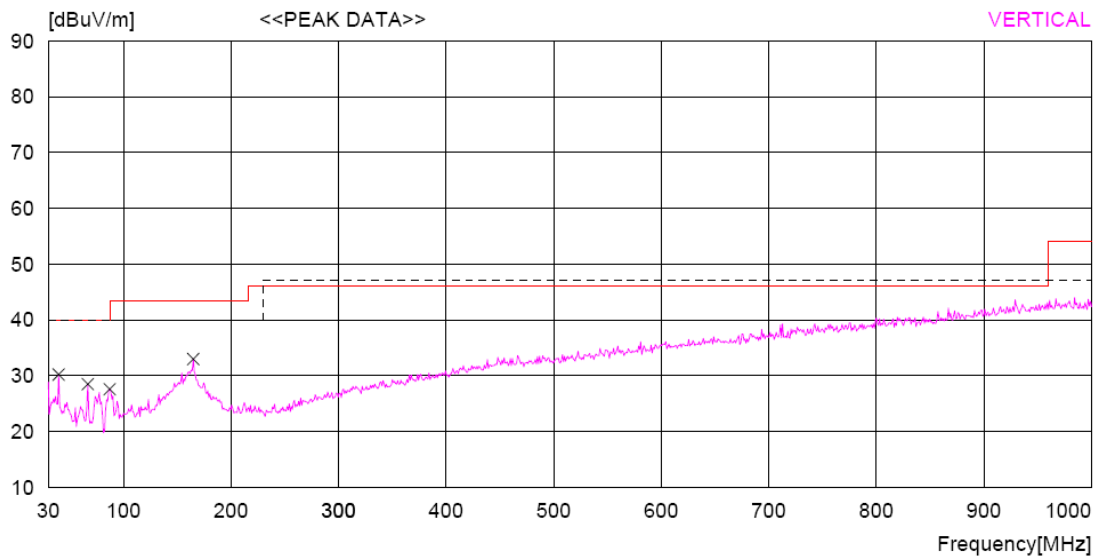

Frequency MHz	Reading dBuV	P (H, V)	Ant. Factor dB	Cable Loss dB	AMP GAIN dB	Limit dBuV	Total dBuV	Margin dB
*39.70	17.10	V	11.53	1.07	0.0	40.00	29.70	-10.30
66.86	17.10	V	10.18	1.28	0.0	40.00	28.56	-11.44
87.23	16.80	V	7.63	1.57	0.0	40.00	26.00	-14.00
164.83	11.20	V	16.13	1.99	0.0	43.50	29.32	-14.18

Note :

1. Remark "*" means that the data is the worst emission level.
2. All reading levels are Quasi-peak value.
3. Measurement level = reading level + correct factor

[Applicable]

EUT	RH55K00	PROBE	0.3GHz~1GHz-HOR
POWER	AC 120 V	NOTE	TX-CH15 (2480 MHz)

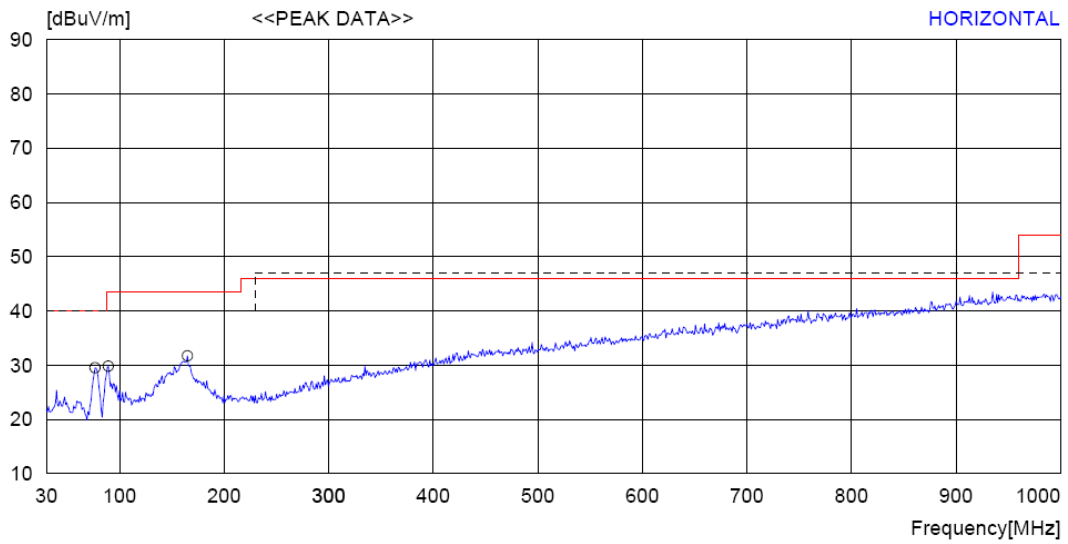

Frequency MHz	Reading dBuV	P (H, V)	Ant. Factor dB	Cable Loss dB	AMP GAIN dB	Limit dBuV	Total dBuV	Margin dB
*76.56	21.20	H	7.86	1.29	0.0	40.00	30.35	-9.65
89.17	18.30	H	7.88	1.73	0.0	40.00	27.91	-12.09
164.83	9.90	H	16.13	1.99	0.0	43.50	28.02	-15.48

Note :

1. Remark "*" means that the data is the worst emission level.
2. All reading levels are *Quasi-peak* value.
3. *Measurement level* = *reading level* + *correct factor*

[Applicable]

EUT	RH55K00	PROBE	0.3GHz~1GHz-VER
POWER	AC 120 V	NOTE	TX-CH15 (2480 MHz)

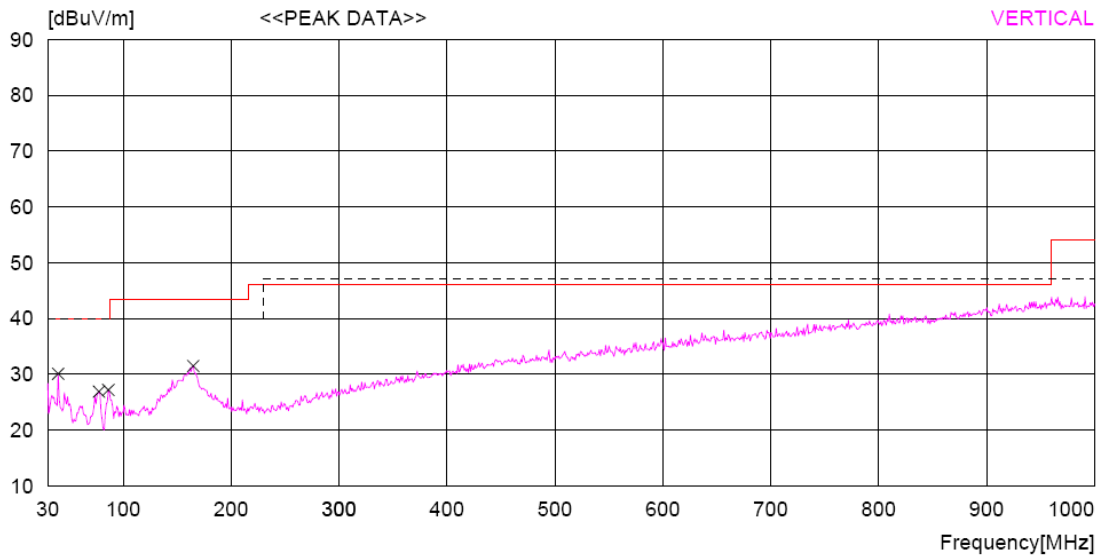

Frequency MHz	Reading dBuV	P (H, V)	Ant. Factor dB	Cable Loss dB	AMP GAIN dB	Limit dBuV	Total dBuV	Margin dB
*39.70	17.00	V	11.53	1.07	0.0	40.00	29.60	-10.40
77.53	18.40	V	7.83	1.35	0.0	40.00	27.58	-12.42
86.26	16.70	V	7.50	1.50	0.0	40.00	25.70	-14.30
164.83	9.70	V	16.13	1.99	0.0	43.50	27.82	-15.68

Note :

1. Remark "*" means that the data is the worst emission level.
2. All reading levels are Quasi-peak value.
3. Measurement level = reading level + correct factor

Radiated Emissions Result

(Disturbance Radiation)

[Applicable]

EUT	RH55K00	PROBE	RF 1GHZ~26GHz-VER
POWER	AC 120 V	NOTE	TX-CH1 (2405 MHz)

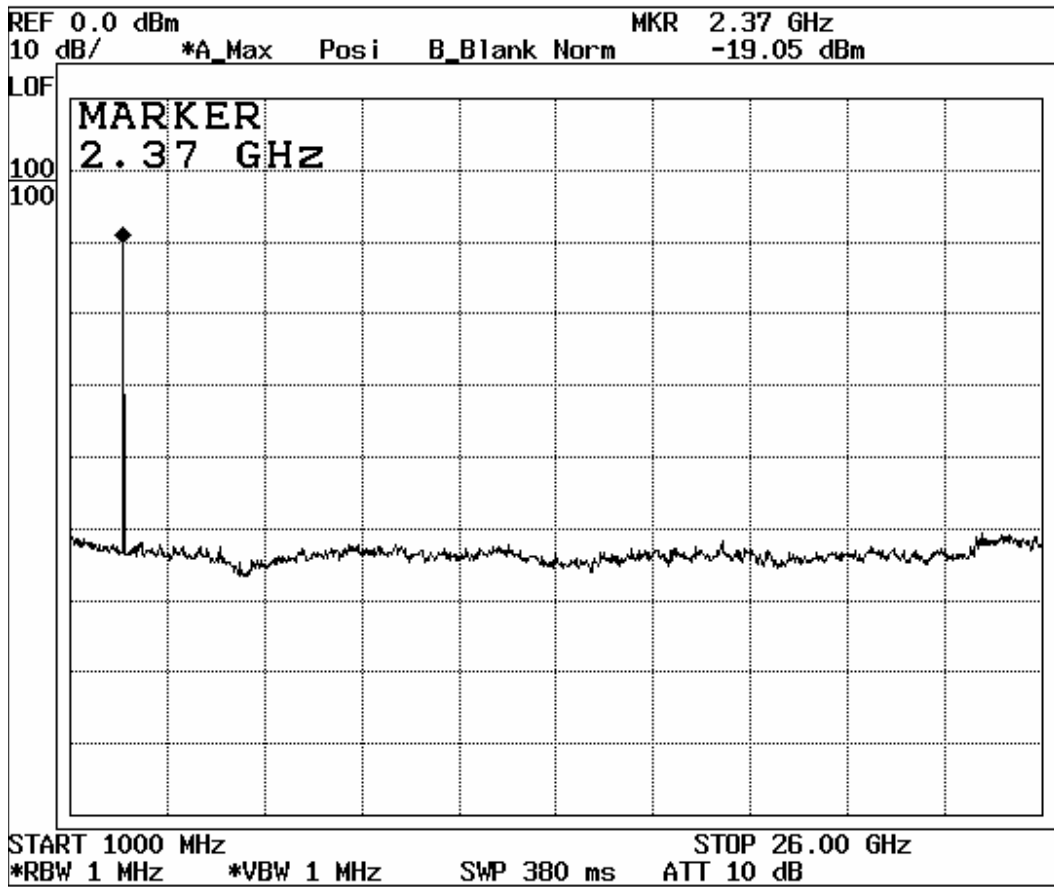

Frequency MHz	Reading dBuV	P (H, V)	Ant. Factor dB	Cable Loss dB	AMP GAIN dB	Total dBuV	Limit dBuV	Margin dB
-	-	-	-	-	-	-	-	-

Note : Other emissions don't exceed the level of 20 dB below the applicable Limit.

[Applicable]

EUT	RH55K00	PROBE	RF 1GHZ~26GHz-HOR
POWER	AC 120 V	NOTE	TX-CH1 (2405 MHz)

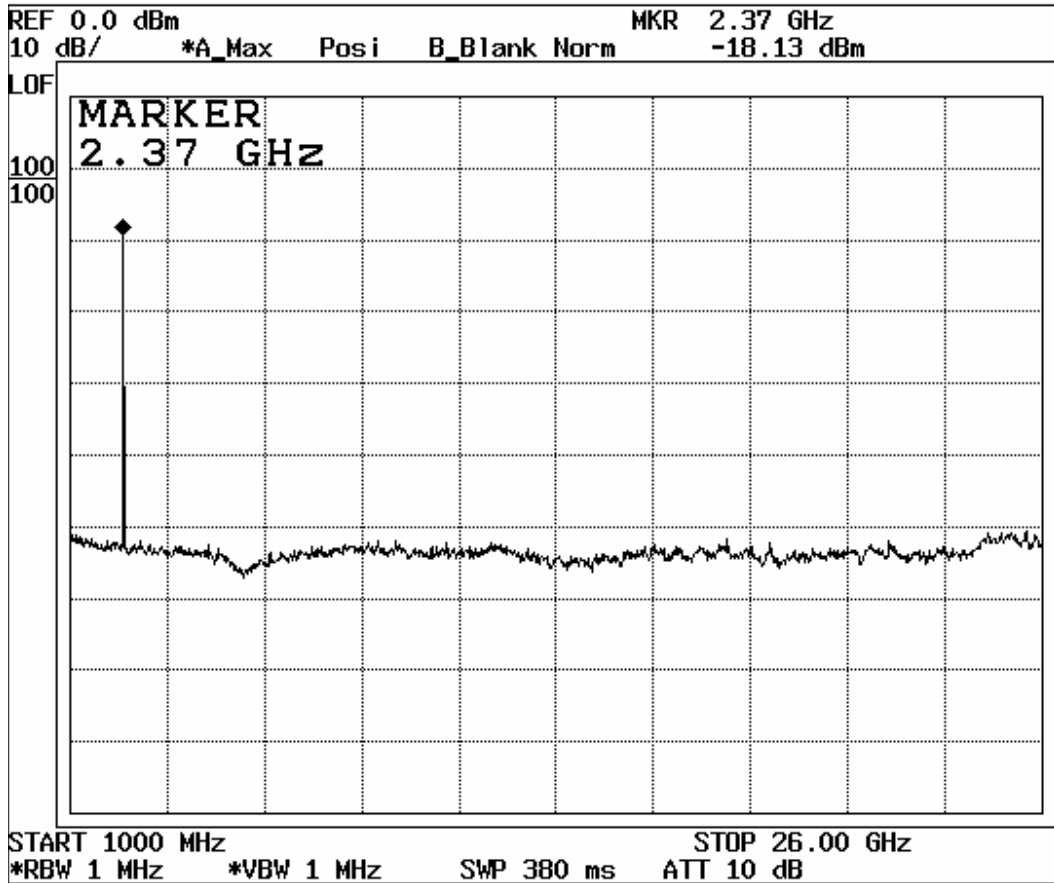

Frequency MHz	Reading dBuV	P (H, V)	Ant. Factor dB	Cable Loss dB	AMP GAIN dB	Total dBuV	Limit dBuV	Margin dB
-	-	-	-	-	-	-	-	-

Note : Other emissions don't exceed the level of 20 dB below the applicable Limit.

[Applicable]

EUT	RH55K00	PROBE	RF 1GHZ~26GHz-VER
POWER	AC 120 V	NOTE	TX-CH8 (2445 MHz)

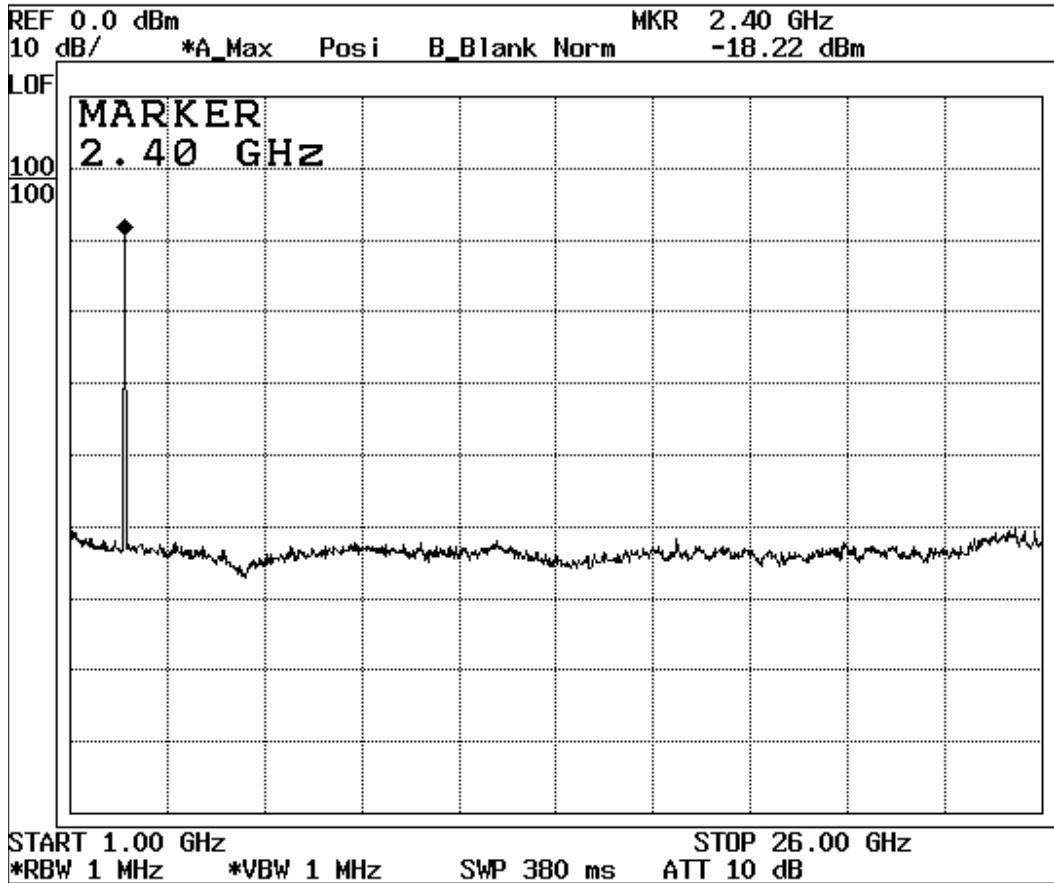

Frequency MHz	Reading dBuV	P (H, V)	Ant. Factor dB	Cable Loss dB	AMP GAIN dB	Total dBuV	Limit dBuV	Margin dB
-	-	-	-	-	-	-	-	-

Note : Other emissions don't exceed the level of 20 dB below the applicable Limit.

[Applicable]

EUT	RH55K00	PROBE	RF 1GHZ~26GHz-HOR
POWER	AC 120 V	NOTE	TX-CH8 (2445 MHz)

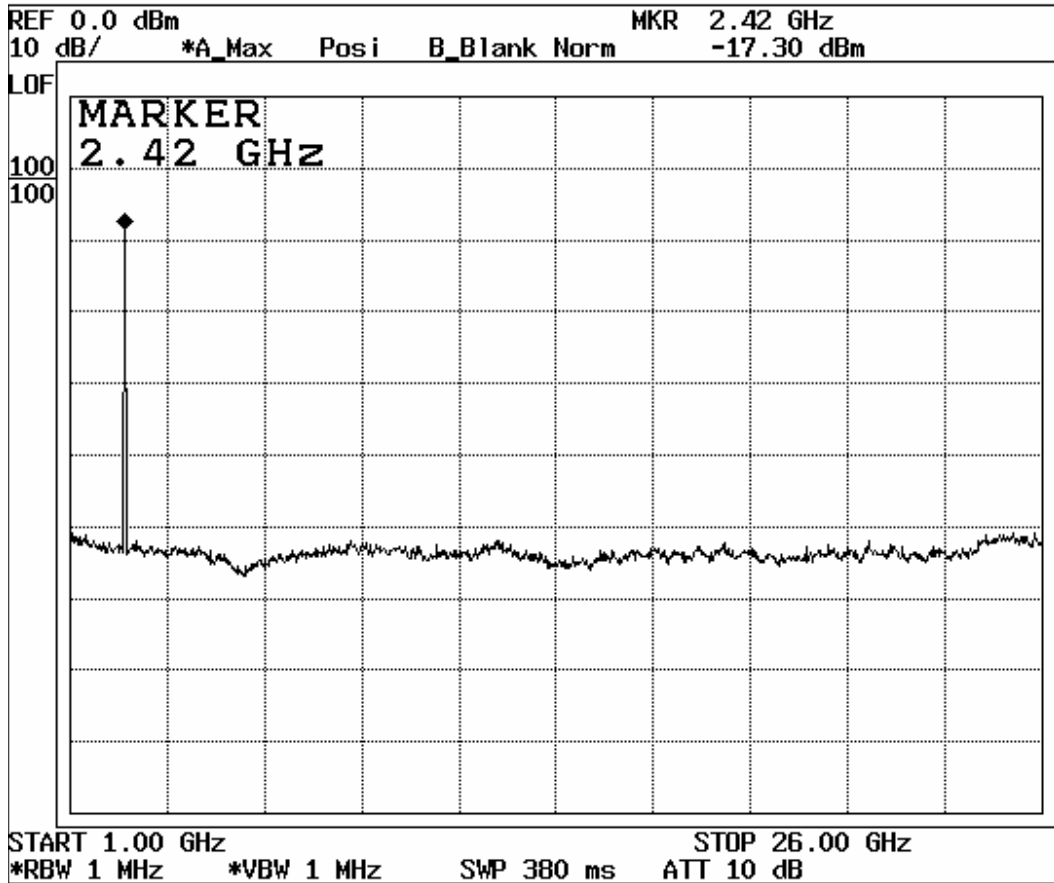

Frequency MHz	Reading dBuV	P (H, V)	Ant. Factor dB	Cable Loss dB	AMP GAIN dB	Total dBuV	Limit dBuV	Margin dB
-	-	-	-	-	-	-	-	-

Note : Other emissions don't exceed the level of 20 dB below the applicable Limit.

[Applicable]

EUT	RH55K00	PROBE	RF 1GHZ~26GHz-VER
POWER	AC 120 V	NOTE	TX-CH15 (2480 MHz)

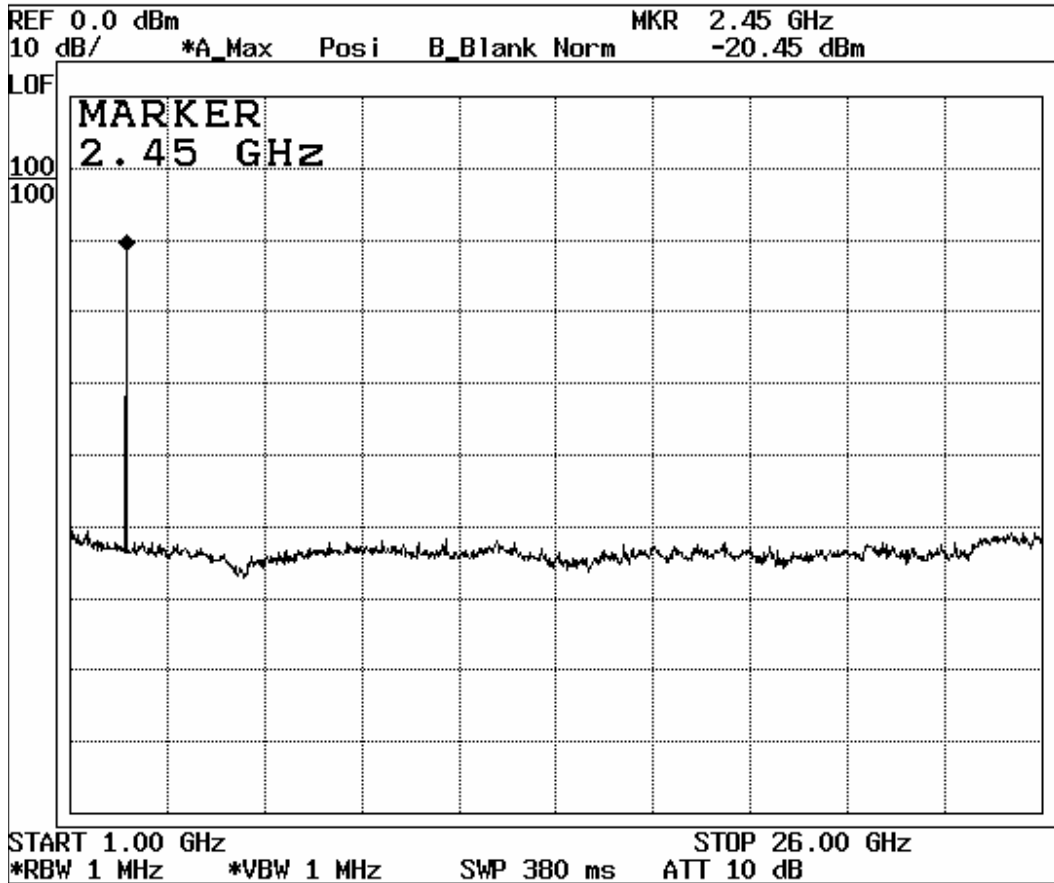

Frequency MHz	Reading dBuV	P (H, V)	Ant. Factor dB	Cable Loss dB	AMP GAIN dB	Total dBuV	Limit dBuV	Margin dB
-	-	-	-	-	-	-	-	-

Note : Other emissions don't exceed the level of 20 dB below the applicable Limit.

[Applicable]

EUT	RH55K00	PROBE	RF 1GHZ~26GHZ-HOR
POWER	AC 120 V	NOTE	TX-CH15 (2480 MHz)

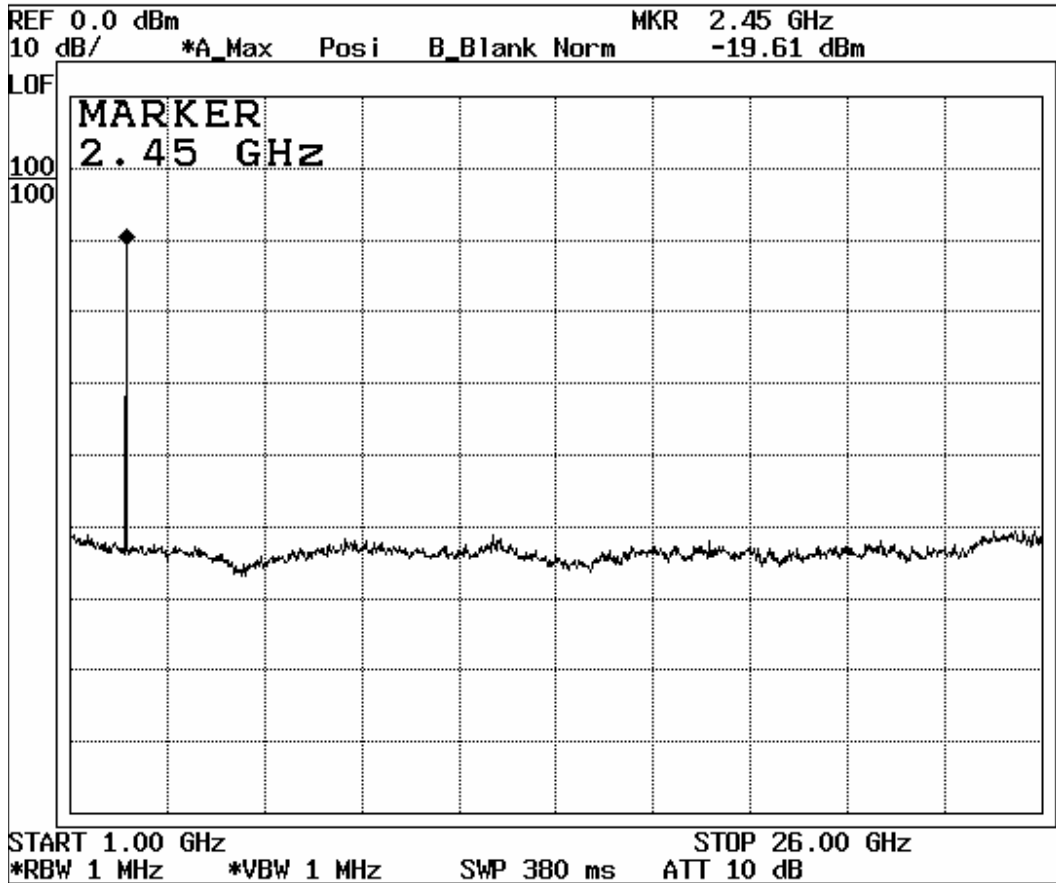

Frequency MHz	Reading dBuV	P (H, V)	Ant. Factor dB	Cable Loss dB	AMP GAIN dB	Total dBuV	Limit dBuV	Margin dB
-	-	-	-	-	-	-	-	-

Note : Other emissions don't exceed the level of 20 dB below the applicable Limit.

Peak Power Output

◆ Test Equipment

The following test equipment are used during the test:

Item	Equipment	Manufacturer	Model no/Serial No.	Last Cal.
1	Spectrum Analyzer	ADVANTEST	R3273 / 95090431	Aug. 01, 2008
2	RF ROOM			

Note : All equipment upon which need to calibrated are with calibration period of 1 year.

◆ Limits

The maximum peak output power of the intentional radiator shall not exceed the following :

1. According to § 15.247(b)(3), for systems using digital modulation in the bands of 902-928 MHz, 2400-2483.5 MHz, and 5725-5850 MHz : 1Watt.
2. According to § 15.247(b)(4), the conducted output power limit specified in paragraph(b) of this section is based on the use of antennas with directional gains that do not exceed 6 dBi. Except as shown in paragraph(c) of this section, is transmitting antennas of directional gain greater than 6 dBi are used, the conducted output power from the intentional radiator shall be reduced below the stated values in paragraphs(b)(1), (b)(2), and (b)(3) of this section, as appropriate, by the amount in dB that the directional gain of the antenna exceeds 6 dBi

◆ Test Setup

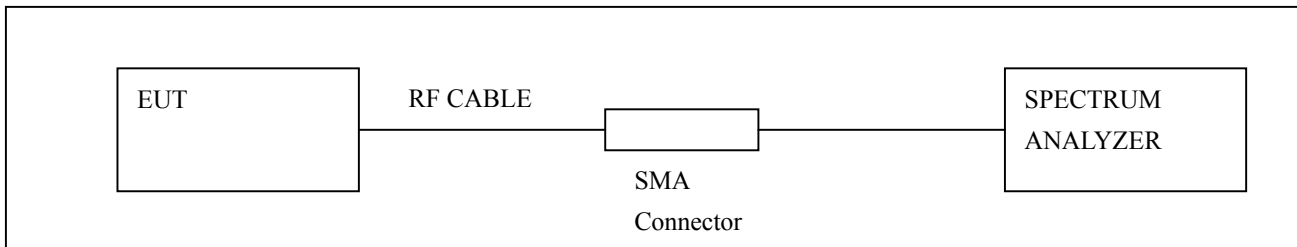

◆ Test Procedure

The transmitter output is connected to the Spectrum analyzer. The Spectrum analyzer is set to the peak power detection.

Peak Power Test result

Product	RH55K00
Test Item	Peak Power Output
Test Mode	Transmit
Test Site	RF Room
Measurement Method	Conducted

Channel No.	Frequency (MHz)	Measure Level (dBm)	Limit (dBm)	Result
1	2405	-7.50	1Watt=30dBm	Pass
8	2445	-4.55	1Watt=30dBm	Pass
15	2480	-3.41	1Watt=30dBm	Pass

Channel 1.

Channel 8.

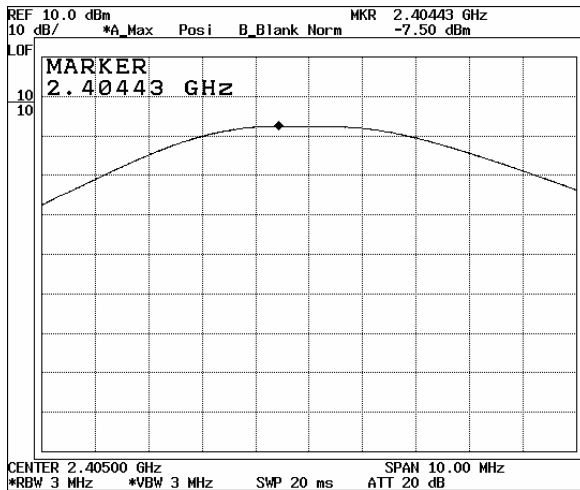

Channel 15

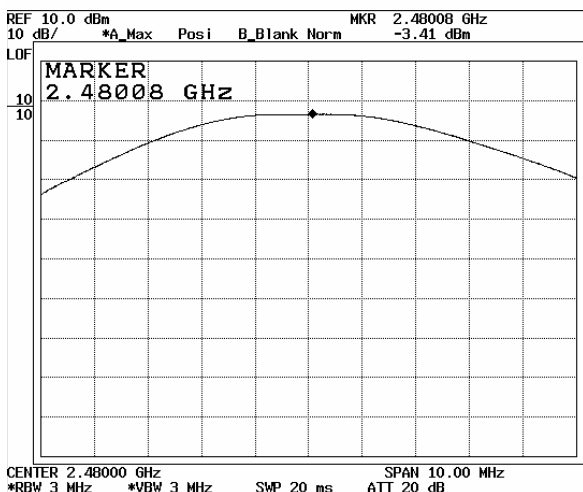
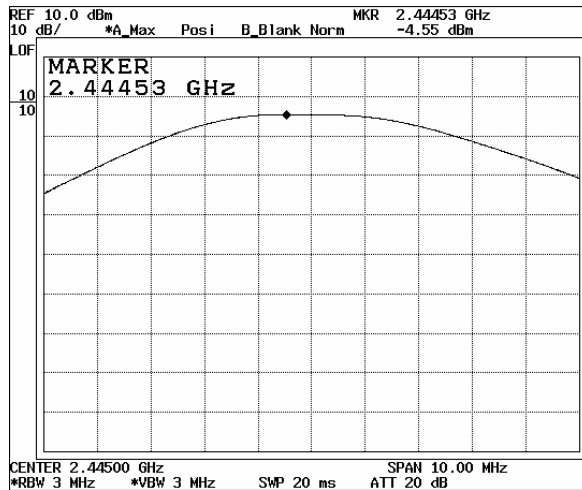

Note : Measurement level = reading level + correct factor

Band Edge

◆TEST Equipment

The following test equipment are used during the test:

Name	Type	Manufacturer	Calibration. Date	Serial Number
ESCS30	EMI Receiver	Rohde & Schwarz	Aug. 10, 2007	100373
SPECTRUM ANALYZER	R3273	ADVANTEST	Oct. 01, 2007	MY420000092
BICONILOG Antenna	VULB 9160	Schwarz beck	Aug. 28, 2007	3047
HORN-Antenna	3115	EMCO	Dec. 26, 2007	9012-3602
HORN-Antenna	SAS-571	A.H. SYSTEMS	Dec. 26, 2007	500
PRE AMPLIFIER	8449B OPT H02	Rohde & Schwarz	Oct. 17, 2007	3008A0530

Note : 1. The calibration interval of the above test instruments is 12 months and the calibrations are traceable to RRL, KRISS, KTL and HCT.

2. The calibration interval of horn ant. and loop ant. is 24 months

◆Limits

In any 100 kHz bandwidth outside the frequency band in which the spread spectrum intentional radiator is operating, the radio Frequency power that is produced by the intentional radiator shall be at least 20 dB below that in the 100 kHz bandwidth within The band that contains the highest level of the desired power, based on either an RF conducted or a radiated measurement.

Attenuation below the general limits specified in section 15.209(a) is not required. In addition, radiated emission which fall in the restricted bands, as defined in section 15.205(a), must also comply with the radiated emission limits specified in section 15.209(a)(see Section 15.205(c)).

◆ Test setup

RF Conducted Measurement:

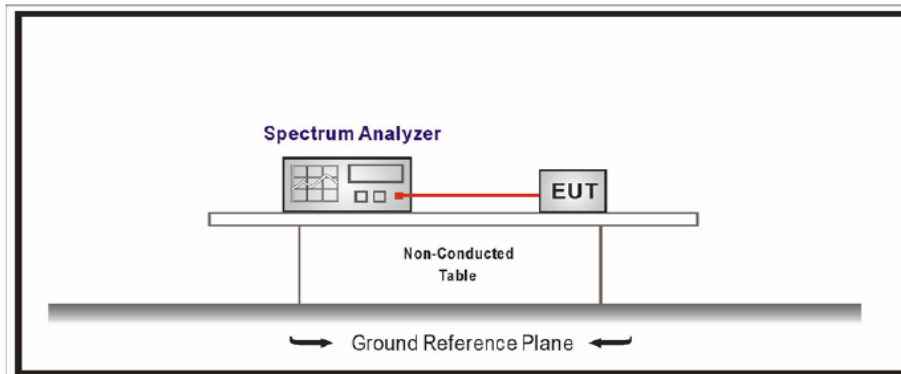

RF Radiated Measurement:

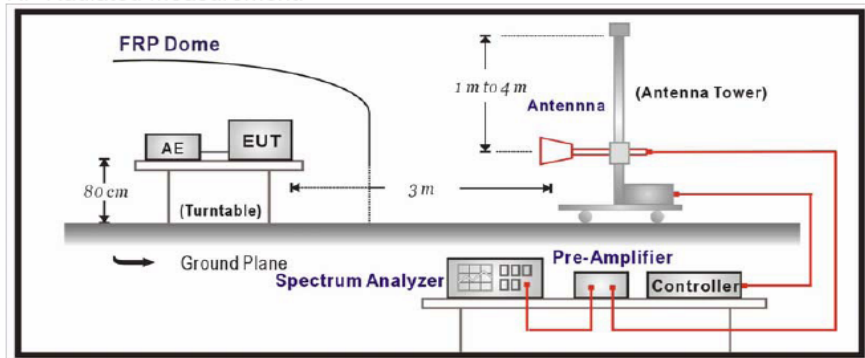

◆ Test procedure

The EUT and its simulators are placed on a turn table which is 0.8 meter above ground. The turn table can rotate 360 degrees to determine the position of the maximum emission level. The EUT was positioned such that the distance from antenna to the EUT was 3 meters. The antenna can move up and down between 1 meter and 4 meters to fine out the maximum emission level.

Both horizontal and vertical polarization of the antenna are set on measurement. In order to find the maximum emission, all of the interface cables must be manipulated according to ANSI C63.4:2003 on radiated measurement.

The bandwidth below 1 GHz setting on the field strength meter is 120 kHz, above 1GHz are 1MHz.

Test specification

According to FCC Part 15 Subpart C paragraph 15.247:2005

Band Edge Test result

Product	RH55K00
Test Item	Band Edge
Test Mode	Transmit
Test Site	RF Room
Measurement Method	Conducted

Detect mode : Peak

Channel : 1 CH(2405 MHz)-Ver.

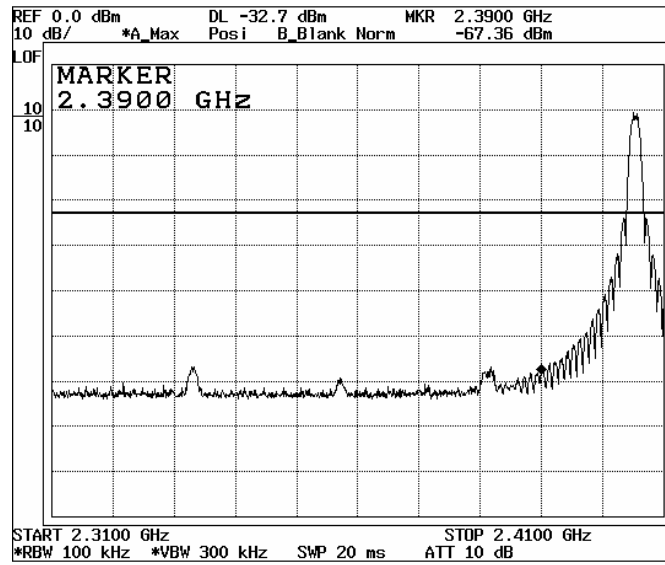

Detect mode : Peak

Channel : 15 CH(2480 MHz)-Hor.

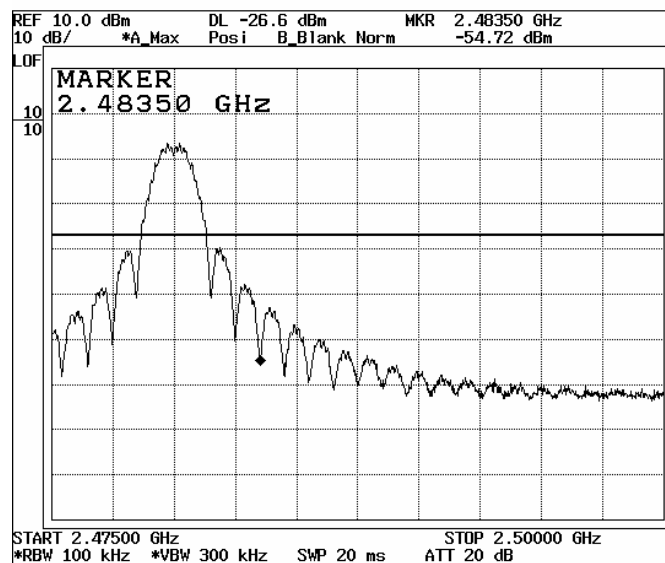

Product	RH55K00
Test Item	Band Edge
Test Mode	Transmit
Test Site	Radiated Measure Room #1
Measurement Method	Radiated-Enclosure

Detect mode : Peak

Channel : 1 CH(2405 MHz)-Ver.

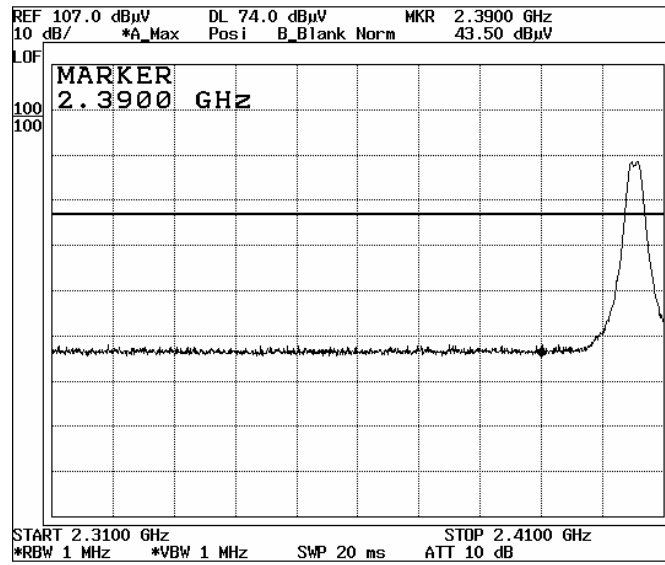

Detect mode : Peak

Channel : 1 CH(2405 MHz)-Hor.

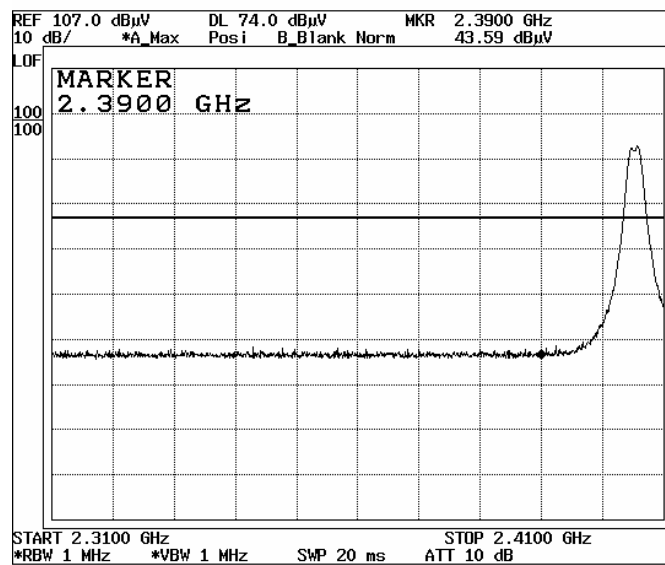

Detect mode : Average

Channel : 1 CH(2405 MHz)-Ver.

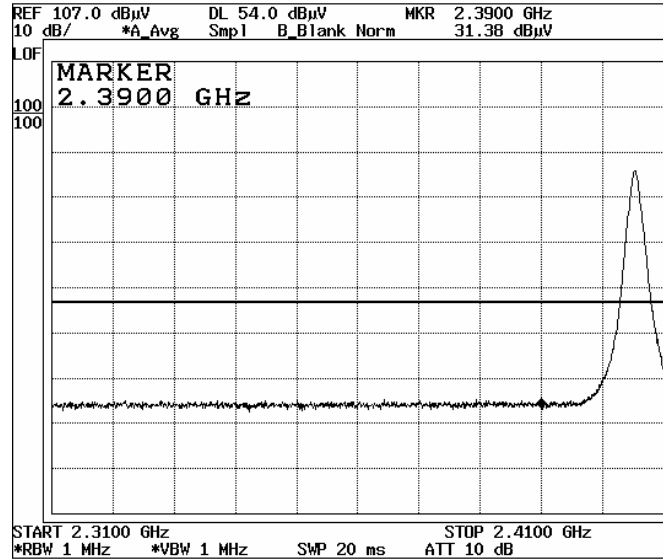

Detect mode : Average

Channel : 1 CH(2405MHz)-Hor.



Detect mode : Peak

Channel : 15 CH(2480 MHz)-Ver.

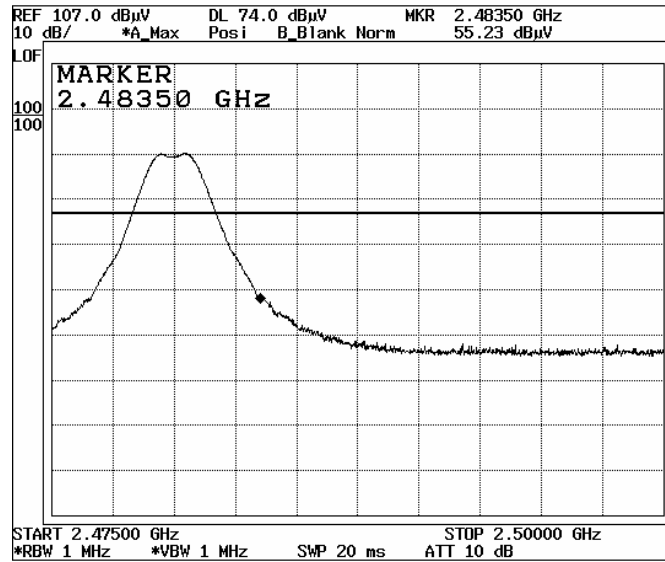

Detect mode : Peak

Channel : 15 CH(2408 MHz)-Hor.

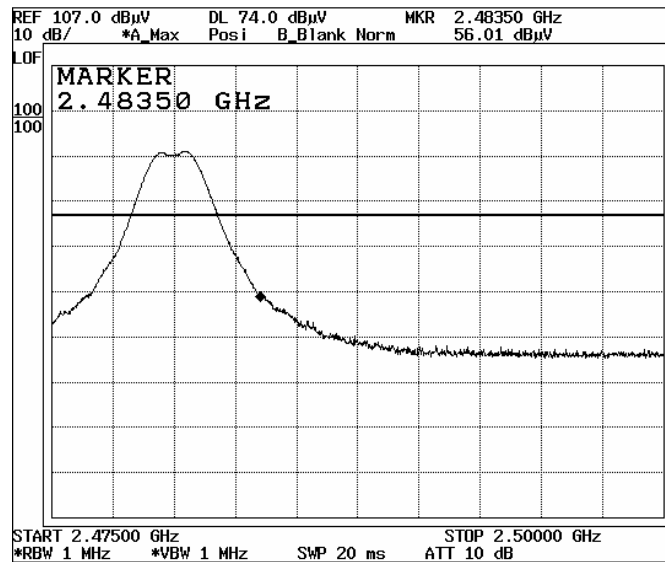

Detect mode : Average

Channel : 15 CH(2480 MHz)-Ver.

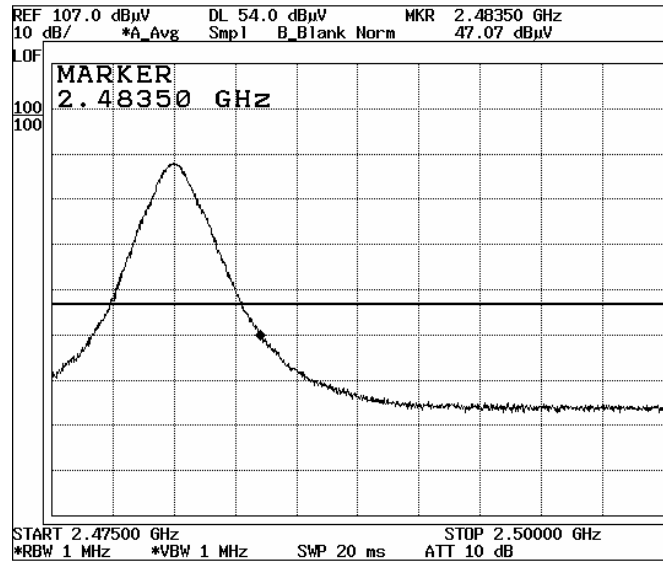

Detect mode : Average

Channel : 15 CH(2480 MHz)-Hor.

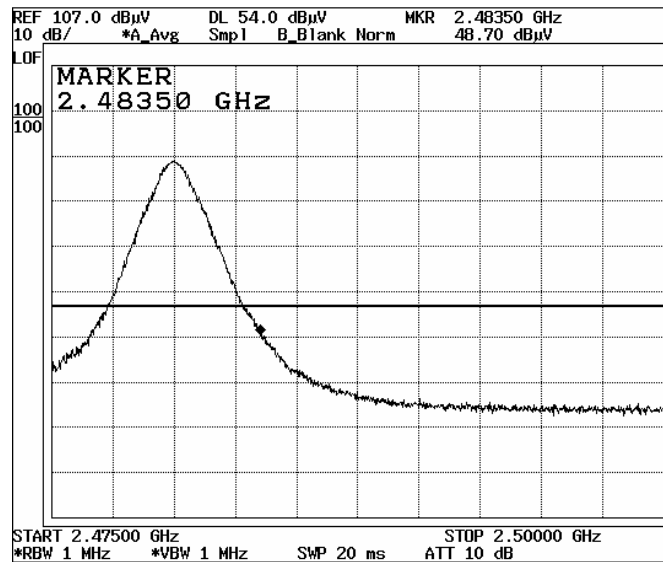

6dB Band

◆Test Equipment

The following test equipment are used during the test:

Item	Equipment	Manufacturer	Model no/Serial No.	Last Cal.
1	Spectrum Analyzer	ADVANTEST	R3273 / 95090431	Aug. 01, 2008
2	RF ROOM			

Note : All equipment upon which need to calibrated are with calibration period of 1 year.

◆Test Setup

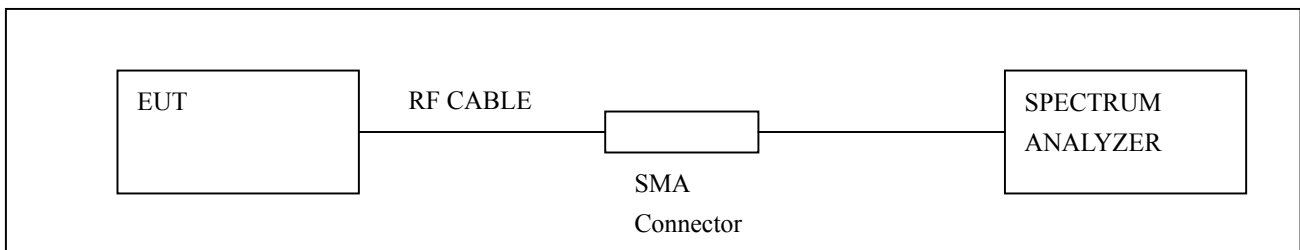

◆Limits

(a) Operation under the provisions of this Section is limited to frequency hopping and digitally modulated intentional radiators that comply with the following provisions :

(2) systems using digital modulation techniques may operate in the 902-928 MHz, 2400-2483.5 MHz, and 5725-5850 MHz bands. The minimum 6 dB bandwidth shall be at least 500 kHz.

◆Test Procedure

The transmitter output is connected to the Spectrum analyzer. The Spectrum analyzer is set to the 6dB Band(Occupied Bandwidth). According to FCC CFR Title 47 Part 15 Subpart C Section 15.247:2005

Test result

Product	RH55K00
Test Item	6dB Band
Test Mode	Transmit
Test Site	RF Room
Measurement Method	Conducted

Channel No.	Frequency (MHz)	Measure Level (KHz)	Limit (KHz)	Result
1	2405	1580	>500	Pass
8	2445	1560	>500	Pass
15	2480	1550	>500	Pass

Channel 1.

Channel 8.

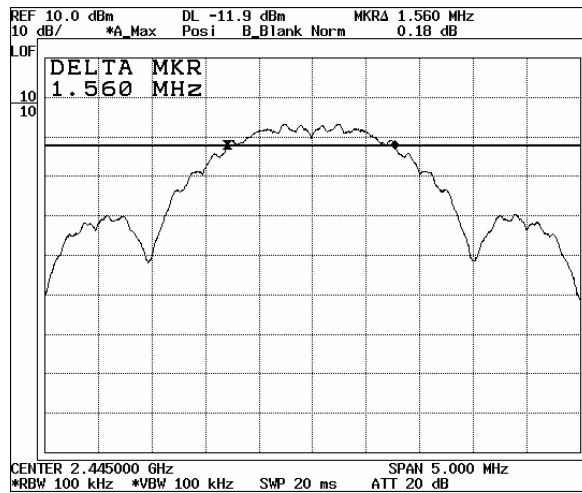
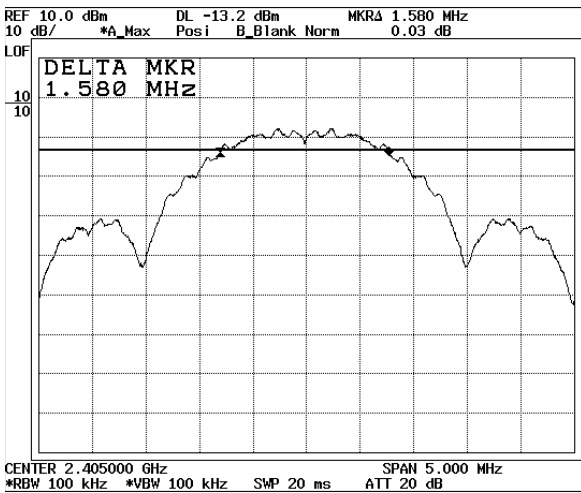

Channel 15

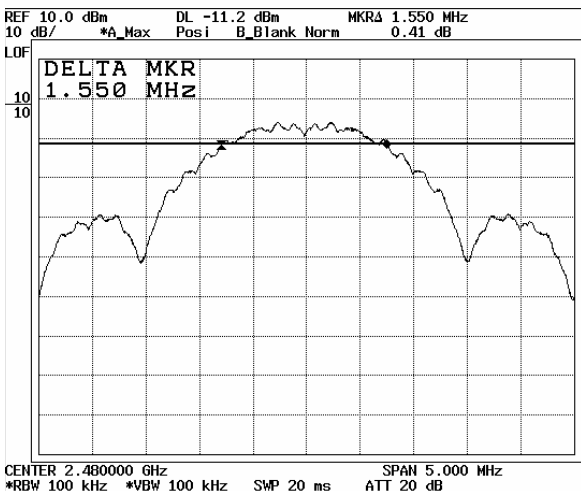

Power Density

◆Test Equipment

The following test equipment are used during the test:

Item	Equipment	Manufacturer	Model no/Serial No.	Last Cal.
1	Spectrum Analyzer	ADVANTEST	R3273 / 95090431	Aug. 01, 2008
2	RF ROOM			

Note : All equipment upon which need to calibrated are with calibration period of 1 year.

◆Test Setup

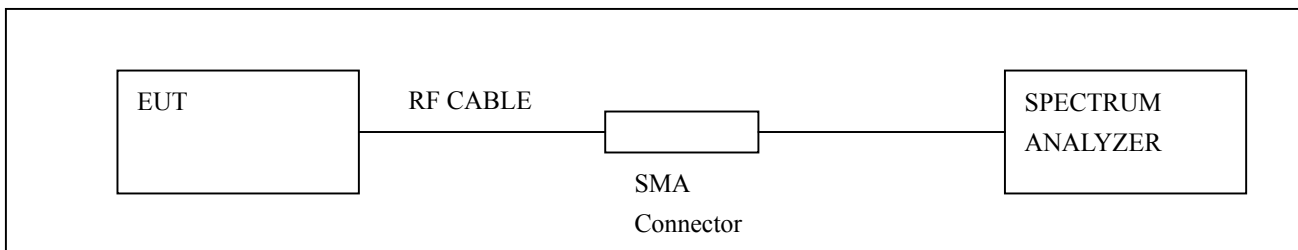

◆Limits

Section 15.247 (e) For digitally modulated systems, the power spectral density conducted from the intentional radiator to the antenna shall not be greater than 8 dBm in any 3 kHz band during any time interval of continuous transmission. This power spectral density shall be determined in accordance with the provisions of paragraph (v) of this section. The same method of determining the conducted output power shall be used to determine the power spectral density.

◆Test Procedure

The transmitter output is connected to the Spectrum analyzer. The Spectrum analyzer is set to the 6dB Band(Occupied Bandwidth). According to FCC CFR Title 47 Part 15 Subpart C Section 15.247:2005

Test result

Product	RH55K00
Test Item	Power Density
Test Mode	Transmit
Test Site	RF Room
Measurement Method	Conducted

Channel No.	Frequency (MHz)	Measure Level (dBm)	Limit (dBm)	Result
1	2405	-22.11	< 8	Pass
8	2445	-19.88	< 8	Pass
15	2480	-18.52	< 8	Pass

Channel 1.

Channel 8.

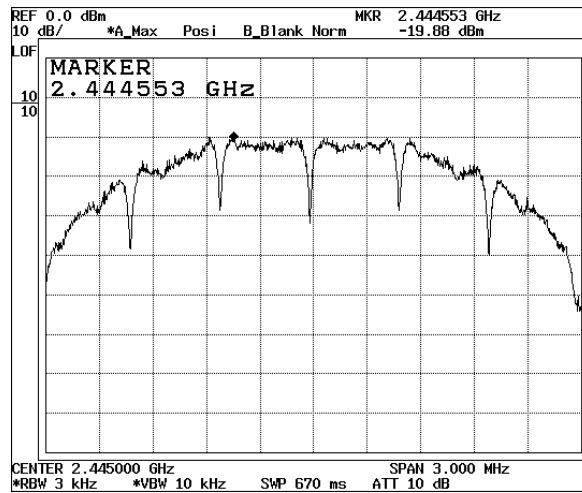

Channel 15



Note : Measurement level = reading level + correct factor

Appendix A. The Photos of Test Setup



Conducted Emissions - Front View

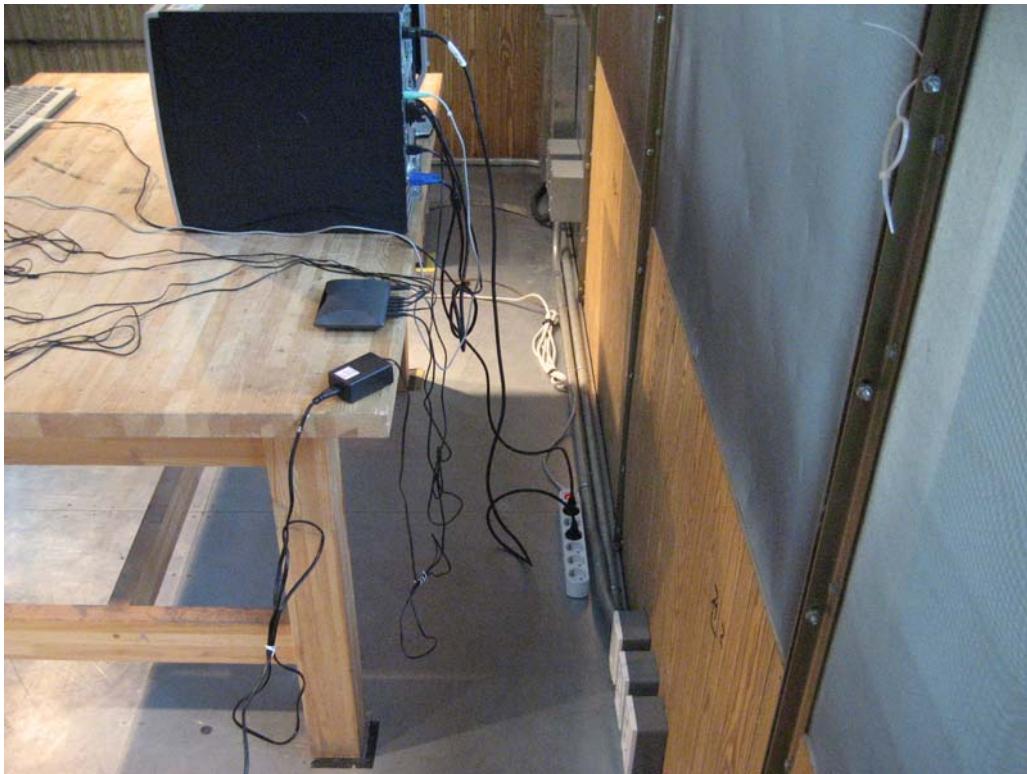

Conducted Emissions) - Rear View

Appendix A. The Photos of Test Setup

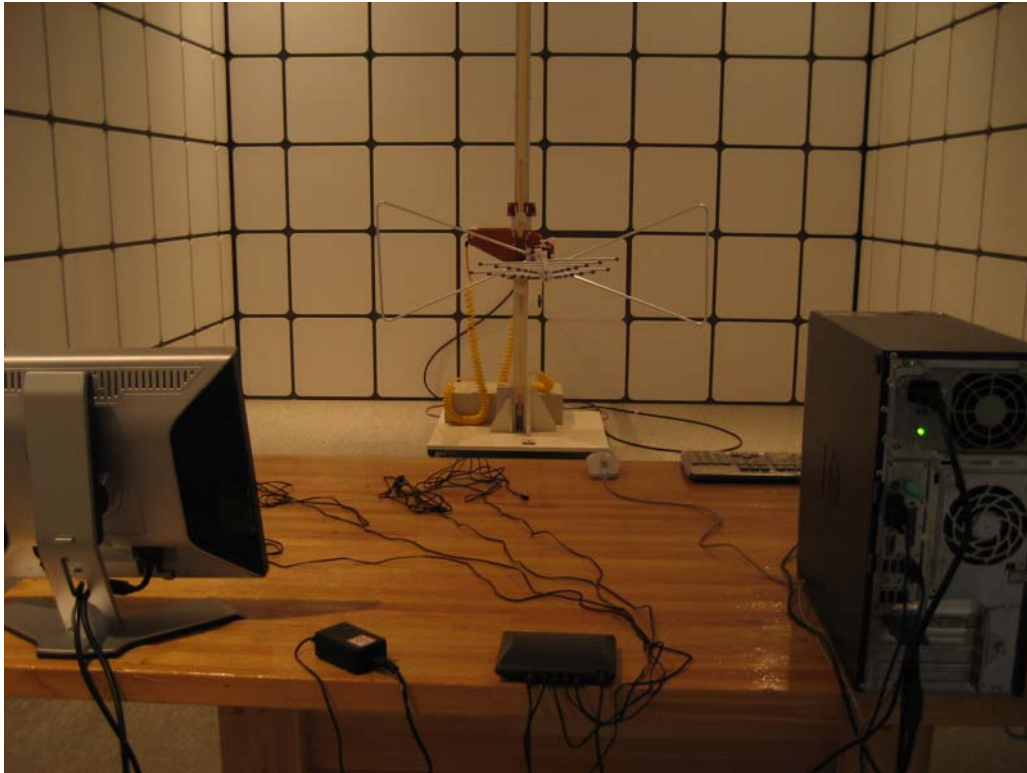

Radiated Emissions(30MHz~1000MHz) - Serial Communication Mode

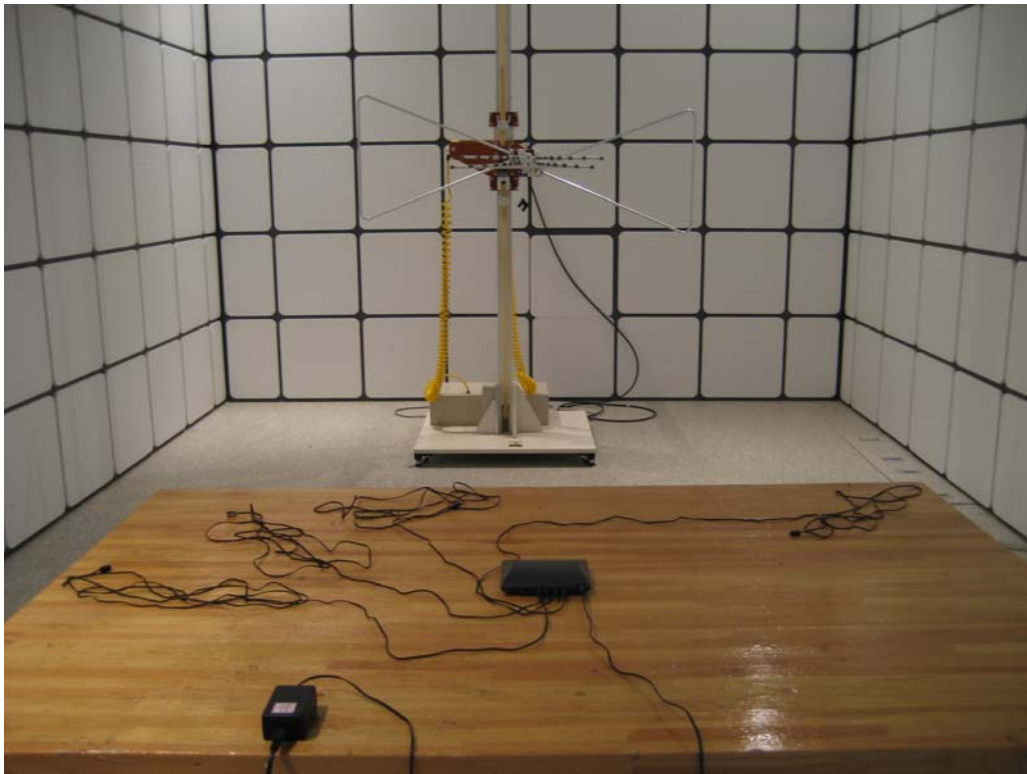

Radiated Emissions(30MHz~1000MHz) - Continue Transmit

Appendix A. The Photos of Test Setup

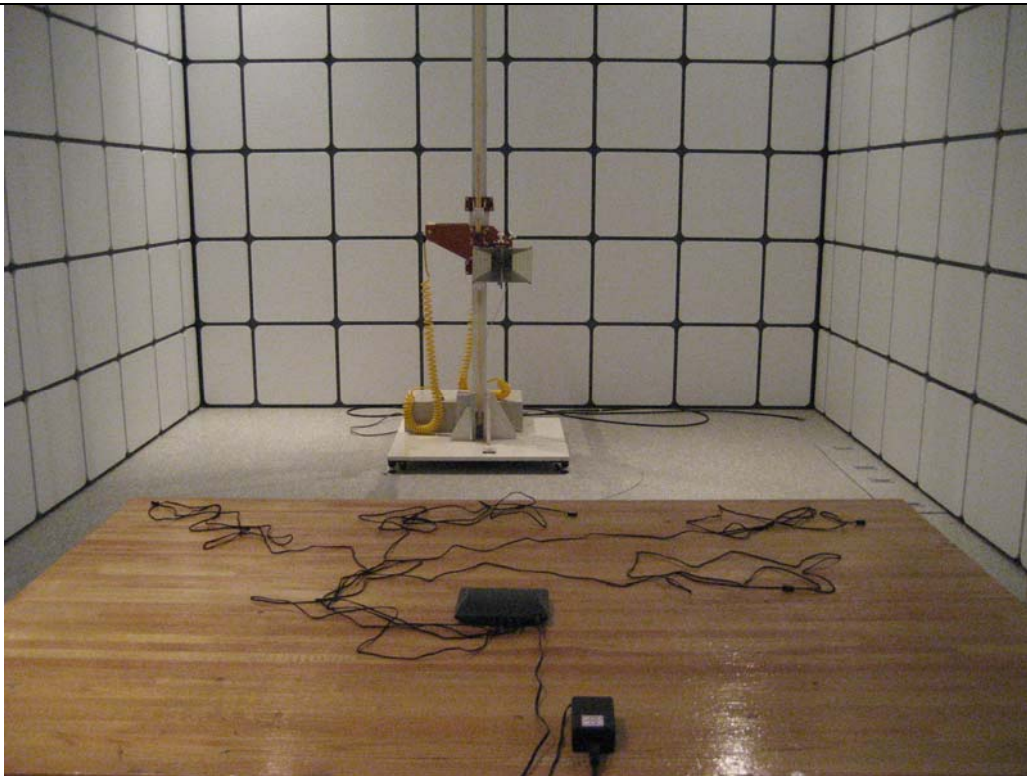

Radiated Emissions(1000MHz~1800MHz)

Appendix B. The Photos of Equipment Under Test



Front view



Rear view