

ELECTROMAGNETIC EMISSION COMPLIANCE REPORT FOR LOW-POWER, NON-LICENSED TRANSMITTER

Test Report No. : E139R-052

AGR No. : A138A-111R

Applicant : Remote Solution Co., Ltd.
Address : 92, Chogokri, Nammyun, Kimchon city, Kyungbuk, Korea, 740-871

Manufacturer : Remote Solution Co., Ltd.
Address : 92, Chogokri, Nammyun, Kimchon city, Kyungbuk, Korea, 740-871

Type of Equipment : Remote Control

FCC ID. : TX4RC44A

Model Name : RC44A

Multiple Model Name : SUR-0500

Serial number : N/A

Total page of Report : 69 pages (including this page)

Date of Incoming : September 05, 2013

Date of issue : September 25, 2013

SUMMARY

The equipment complies with the regulation; *FCC PART 15 SUBPART C Section 15.247*

This test report only contains the result of a single test of the sample supplied for the examination.

It is not a generally valid assessment of the features of the respective products of the mass-production.

Prepared by:

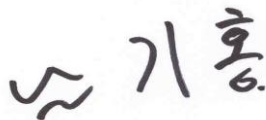

Ki-Hong, Nam / Senior Engineer
ONETECH Corp.

Approved by:

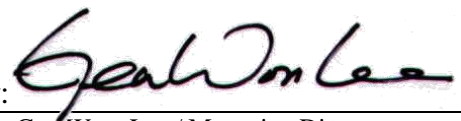

Gea-Won, Lee / Managing Director
ONETECH Corp.

CONTENTS

	PAGE
1. VERIFICATION OF COMPLIANCE	6
2. TEST SUMMARY	7
2.1 TEST ITEMS AND RESULTS	7
2.2 ADDITIONS, DEVIATIONS, EXCLUSIONS FROM STANDARDS	7
2.3 RELATED SUBMITTAL(S) / GRANT(S)	7
2.4 PURPOSE OF THE TEST	7
2.5 TEST METHODOLOGY	7
2.6 TEST FACILITY	7
3. GENERAL INFORMATION	8
3.1 PRODUCT DESCRIPTION	8
3.2 ALTERNATIVE TYPE(S)/MODEL(S); ALSO COVERED BY THIS TEST REPORT	8
4. EUT MODIFICATIONS	8
5. SYSTEM TEST CONFIGURATION	9
5.1 JUSTIFICATION	9
5.2 PERIPHERAL EQUIPMENT	9
5.3 MODE OF OPERATION DURING THE TEST	10
6. PRELIMINARY TEST	12
6.1 AC POWER LINE CONDUCTED EMISSIONS TESTS	12
6.2 GENERAL RADIATED EMISSIONS TESTS	12
7. MIMIMUM 6 DB BANDWIDTH	13
7.1 OPERATING ENVIRONMENT	13
7.2 TEST SET-UP	13
7.3 TEST EQUIPMENT USED	13
7.4 TEST DATA FOR 802.11B MODE	14
7.5 TEST DATA FOR 802.11G MODE	16
7.6 TEST DATA FOR 802.11N MODE	18
8. MAXIMUM PEAK OUTPUT POWER	20
8.1 OPERATING ENVIRONMENT	20
8.2 TEST SET-UP	20
8.3 TEST EQUIPMENT USED	20
8.4 TEST DATA FOR 802.11B MODE	21

8.5 TEST DATA FOR 802.11G MODE23

8.6 TEST DATA FOR 802.11N MODE.....25

9. 100 KHZ BANDWIDTH OUTSIDE THE FREQUENCY BAND.....27

9.1 OPERATING ENVIRONMENT27

9.2 TEST SET-UP FOR CONDUCTED MEASUREMENT27

9.3 TEST SET-UP FOR RADIATED MEASUREMENT.....27

9.4 TEST EQUIPMENT USED.....27

9.5 TEST DATA FOR CONDUCTED EMISSION28

 9.5.1 Test data for 802.11b Mode28

 9.5.2 Test data for 802.11g Mode33

 9.5.3 Test data for 802.11n Mode38

9.6 TEST DATA FOR RADIATED EMISSION43

 9.6.1 Radiated Emission which fall in the Restricted Band.....43

 9.6.2 Spurious & Harmonic Radiated Emission.....46

10 PEAK POWER SPECTRUL DENSITY52

10.1 OPERATING ENVIRONMENT52

10.2 TEST SET-UP52

10.3 TEST EQUIPMENT USED.....52

10.4 TEST DATA FOR 802.11B MODE.....53

10.5 TEST DATA FOR 802.11G MODE55

10.6 TEST DATA FOR 802.11N MODE.....57

11. RADIATED EMISSION TEST59

11.1 OPERATING ENVIRONMENT59

11.2 TEST SET-UP59

11.3 TEST EQUIPMENT USED.....59

11.4 TEST DATA FOR 802.11B MODE.....60

 11.4.1 Test data for 30 MHz ~ 1 000 MHz.....60

 11.4.2 Test data for Below 30 MHz.....62

 11.4.3 Test data for above 1 GHz62

11.5 TEST DATA FOR 802.11G MODE63

 11.5.1 Test data for 30 MHz ~ 1 000 MHz.....63

 11.5.2 Test data for Below 30 MHz.....65

 11.5.3 Test data for above 1 GHz65

11.6 TEST DATA FOR 802.11N MODE.....66

 11.6.1 Test data for 30 MHz ~ 1 000 MHz.....66

 11.6.2 Test data for Below 30 MHz.....68

11.6.3 Test data for above 1 GHz68

12. RADIO FREQUENCY EXPOSURE**69**

12.1 RF EXPOSURE LIMIT69

12.2 EUT DESCRIPTION.....69

12.3 TEST RESULT69

Revision History

Issued Report No.	Issued Date	Revisions	Effect Section
E139R-052	September 25, 2013	Initial Issue	All

1. VERIFICATION OF COMPLIANCE

Applicant : Remote Solution Co., Ltd.
 Address : 92, Chogokri, Nammyun, Kimchon city, Kyungbuk, Korea, 740-871
 Contact Person : Young Tae, AHN / Senior Research Engineer
 Telephone No. : +82-31-420-5723
 FCC ID : TX4RC44A
 Model Name : RC44A
 Serial Number : N/A
 Date : September 25, 2013

EQUIPMENT CLASS	<i>DTS – DIGITAL TRNSMISSION SYSTEM</i>
E.U.T. DESCRIPTION	Remote Control
THIS REPORT CONCERNS	Original Grant
MEASUREMENT PROCEDURES	ANSI C63.10: 2009
TYPE OF EQUIPMENT TESTED	Pre-Production
KIND OF EQUIPMENT AUTHORIZATION REQUESTED	Certification
EQUIPMENT WILL BE OPERATED UNDER FCC RULES PART(S)	FCC PART 15 SUBPART C Section 15.247
MODIFICATIONS ON THE EQUIPMENT TO ACHIEVE COMPLIANCE	None
FINAL TEST WAS CONDUCTED ON	3 m semi anechoic chamber.

-. The above equipment was tested by ONETECH Corp. for compliance with the requirement set forth in the FCC Rules and Regulations. This said equipment in the configuration described in this report, shows the maximum emission levels emanating from equipment are within the compliance requirements.

2. TEST SUMMARY

2.1 Test items and results

SECTION	TEST ITEMS	RESULTS
15.247 (a) (2)	Minimum 6 dB Bandwidth	Met the Limit / PASS
15.247 (b) (3)	Maximum Peak Conducted Output Power	Met the Limit / PASS
15.247 (d)	100 kHz Bandwidth Outside the Frequency Band	Met the Limit / PASS
15.247 (d)	Radiated Emission which fall in the Restricted Band	Met the Limit / PASS
15.247 (e)	Peak Power Spectral Density	Met the Limit / PASS
15.209	Radiated Emission Limits	Met the Limit / PASS
15.207	Conducted Limits	Met the Limit / PASS
15.203	Antenna Requirement	Met requirement / PASS

2.2 Additions, deviations, exclusions from standards

No additions, deviations or exclusions have been made from standard.

2.3 Related Submittal(s) / Grant(s)

Original submittal only

2.4 Purpose of the test

To determine whether the equipment under test fulfills the requirements of the regulation stated in section 2.1.

2.5 Test Methodology

Radiated testing was performed according to the procedures in ANSI C63.10: 2009 at a distance of 3 m from EUT to the antenna.

2.6 Test Facility

The open area test site is located at 307-51 Daessangryung-ri, Chowol-eup, Gwangju-si, Gyeonggi-do and 10 m Semi Anechoic Chamber (SAC) and conducted measurement facilities are located at 301-14, Daessangryung-ri, Chowol-eup, Gwangju-si, Gyeonggi-do, 464-862, Korea. The Onetech Corp. has been accredited as a Conformity Assessment Body (CAB) with designation number KR0013 under APEC TEL MAR between the RRA and the FCC.

3. GENERAL INFORMATION

3.1 Product Description

The Remote Solution Co., Ltd., Model RC44A (referred to as the EUT in this report) is a Remote Control. Product specification information described herein was obtained from product data sheet or user’s manual.

DEVICE TYPE	Portable Device
FREQUENCY RANGE	TX: 2 412 MHz ~ 2 462 MHz RX: 2 412 MHz ~ 2 462 MHz
MAX. RF OUTPUT POWER:	802.11b: 3.56 dBm 802.11g: 2.87 dBm 802.11n(HT20): 2.88 dBm
MODULATION TYPE	802.11b: DSSS Modulation(DBPSK/DQPSK/CCK) 802.11g/n(HT20): OFDM Modulation(BPSK/QPSK/16QAM/64QAM)
Number of Channel	11 Channel
Antenna Type	Inserted into the main board (Dielectric Chip Antenna)
USED RF CHIP	Marker: JORJIN TECHNOLOGIES INC. Model Name: WG7311-XA
Antenna Gain	3.40 dBi
List of each Osc. or crystal Freq.(Freq. >= 1 MHz)	24 MHz, 38.4 MHz, 32 KHz

3.2 Alternative type(s)/model(s); also covered by this test report.

-. The following lists consist of the added model and their differences.

Model Name	Differences	Tested
RC44A	Basic Model	<input checked="" type="checkbox"/>
SUR-0500	These models are identical to basic model except for the model name only.	<input type="checkbox"/>

Note: 1. Applicant consigns only basic model to test. Therefore this test report just guarantees the units, which have been tested.

2. The Applicant/manufacturer is responsible for the compliance of all variants.

4. EUT MODIFICATIONS

-. None

5. SYSTEM TEST CONFIGURATION

5.1 Justification

This device was configured for testing in a typical way as a normal customer is supposed to be used. During the test, the following components were installed inside of the EUT.

DEVICE TYPE	MANUFACTURER	MODEL/PART NUMBER	FCC ID
Main Board	Remote Solution Co., Ltd.	1BL-3042B	N/A

5.2 Peripheral equipment

Defined as equipment needed for correct operation of the EUT, but not considered as tested:

Model	Manufacturer	Description	Connected to
RC44A	Remote Solution Co., Ltd.	Remote Control (EUT)	-

5.3 Mode of operation during the test

For the testing, software used to control the EUT for staying in continuous transmitting mode is programmed.

Maximum Output Power

Modulation & Channel selected	DATA RATE	OUTPUT POWER
		Ant 0
802.11 b (Middle Channel)	1 Mbps	3.29
	2 Mbps	3.31
	5.5 Mbps	3.42
	11 Mbps	3.56
802.11g (Middle Channel))	6 Mbps	2.57
	9 Mbps	2.59
	12 Mbps	2.64
	18 Mbps	2.62
	24 Mbps	2.71
	36 Mbps	2.73
	48 Mbps	2.80
	54 Mbps	2.87
HT 20 (Middle Channel))	6.5 Mbps	2.67
	13 Mbps	2.64
	19.5 Mbps	2.69
	26 Mbps	2.75
	39 Mbps	2.79
	52 Mbps	2.84
	58.5 Mbps	2.84
	65 Mbps	2.88

- The worse case data rate for each modulation is determined 11 Mbps for IEEE 802.11b, 54 Mbps for IEEE 802.11g, 65 Mbps for IEEE 802.11n(HT20).

- To get a maximum emission levels from the EUT, the EUT was moved throughout the XY, XZ, and YZ planes and the worst case is “XY” axis.

5.4 Configuration of Test System

Line Conducted Test: It is not need to test this requirement, because the EUT shall be operated by DC battery.

Radiated Emission Test: Preliminary radiated emissions test were conducted using the procedure in ANSI C63.10: 2009 to determine the worse operating conditions. Final radiated emission tests were conducted at 3 m open area test site.

The turntable was rotated through 360 degrees and the EUT was tested by positioned three orthogonal planes to obtain the highest reading on the field strength meter. Once maximum reading was determined, the search antenna was raised and lowered in both vertical and horizontal polarization.

5.5 Antenna Requirement

For intentional device, according to section 15.203, an intentional radiator shall be designed to ensure that no antenna other than that furnished by the responsible party shall be used with the device.

Antenna Construction:

The transmitter antenna of the EUT is a chip antenna, so no consideration of replacement by the user.

6. PRELIMINARY TEST

6.1 AC Power line Conducted Emissions Tests

During Preliminary Tests, the following operating mode was investigated

Operation Mode	The Worse operating condition (Please check one only)
It is not need to test this requirement, because the power of the EUT is supplied by battery.	

6.2 General Radiated Emissions Tests

During Preliminary Tests, the following operating modes were investigated

Operation Mode	The Worse operating condition (Please check one only)
TX Mode	X

7. MIMIMUM 6 dB BANDWIDTH

7.1 Operating environment

Temperature : 24 °C
Relative humidity : 44 % R.H.

7.2 Test set-up

The antenna output of the EUT was connected to the spectrum analyzer. The resolution bandwidth is set to 100 kHz, and peak detection was used. The 6 dB bandwidth is defined as the total spectrum over which the power is higher than the peak power minus 6 dB.

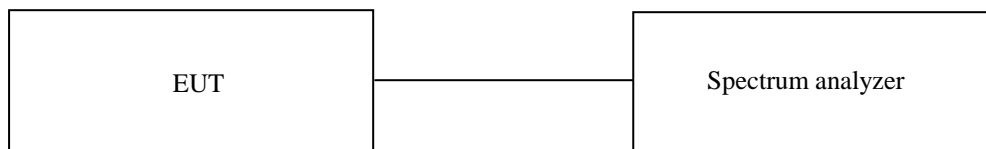

7.3 Test equipment used

Model Number	Manufacturer	Description	Serial Number	Last Cal.
■ - FSV30	R/S	Spectrum Analyzer	101372	May 20, 2013

All test equipment used is calibrated on a regular basis.

7.4 Test data for 802.11b Mode

- Test Date : September 12, 2013
- Test Result : Pass

CHANNEL	FREQUENCY(MHz)	MEASURED VALUE (MHz)	LIMIT (MHz)	MARGIN (MHz)
Low	2 412	9.91	0.5	9.41
Middle	2 442	9.55	0.5	9.05
High	2 462	10.06	0.5	9.56

Remark. Margin = Measured Value - Limit



Tested by: Tae-Ho, Kim / Project Engineer

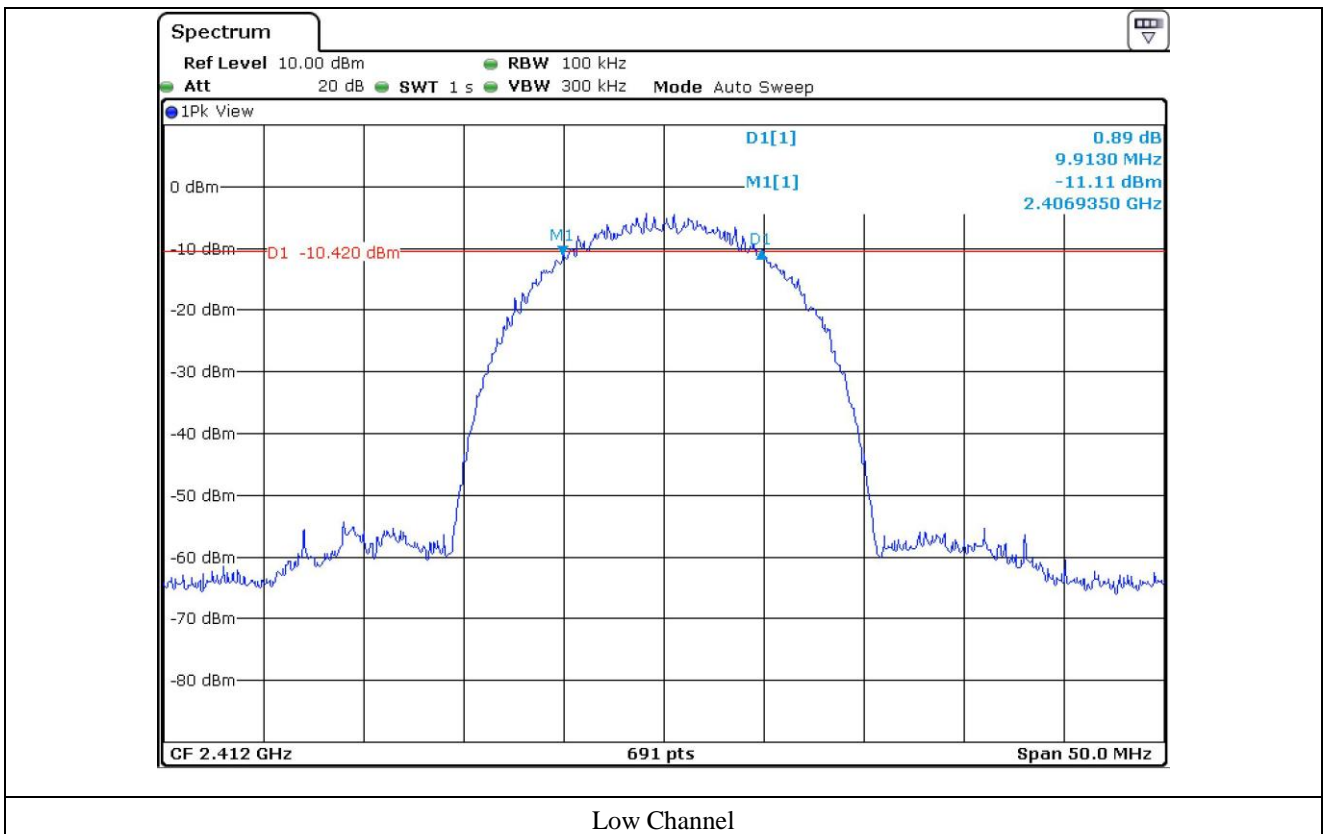

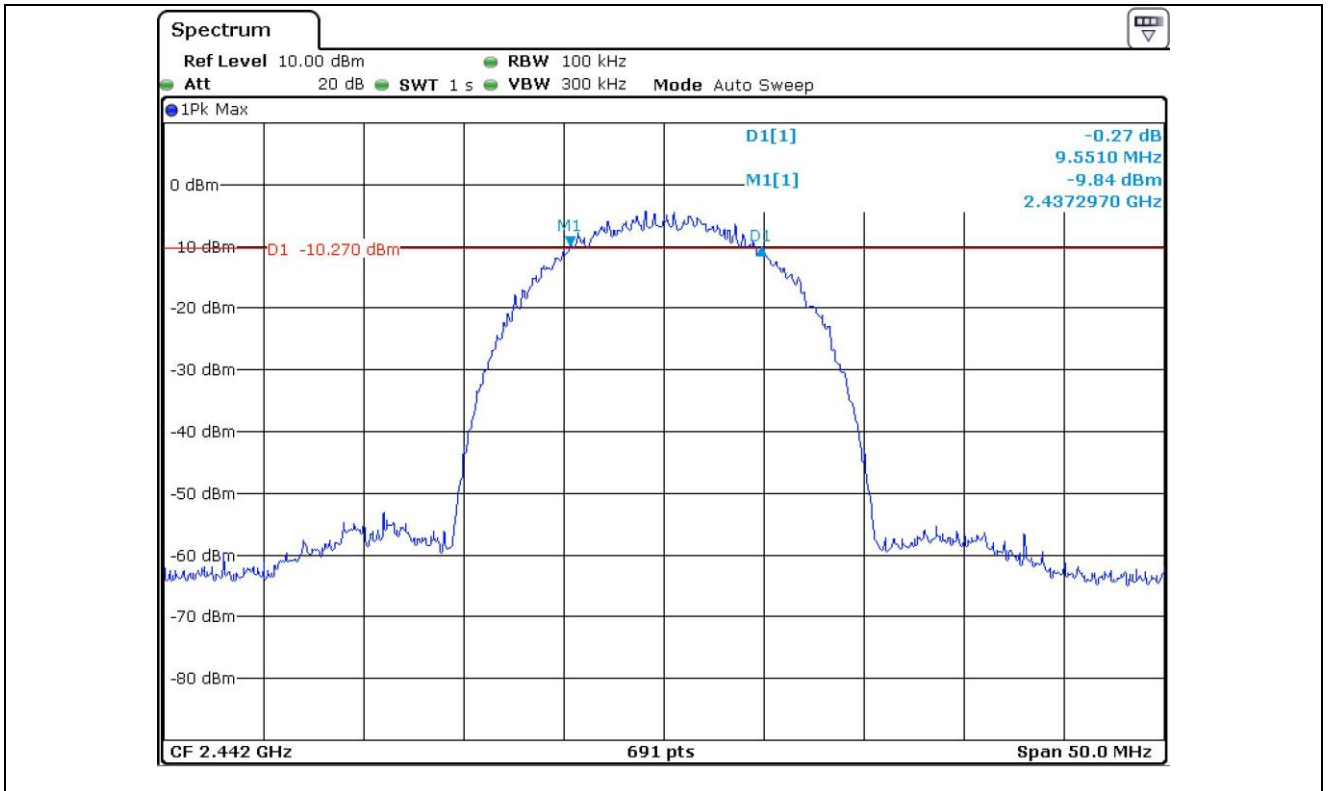

Middle Channel

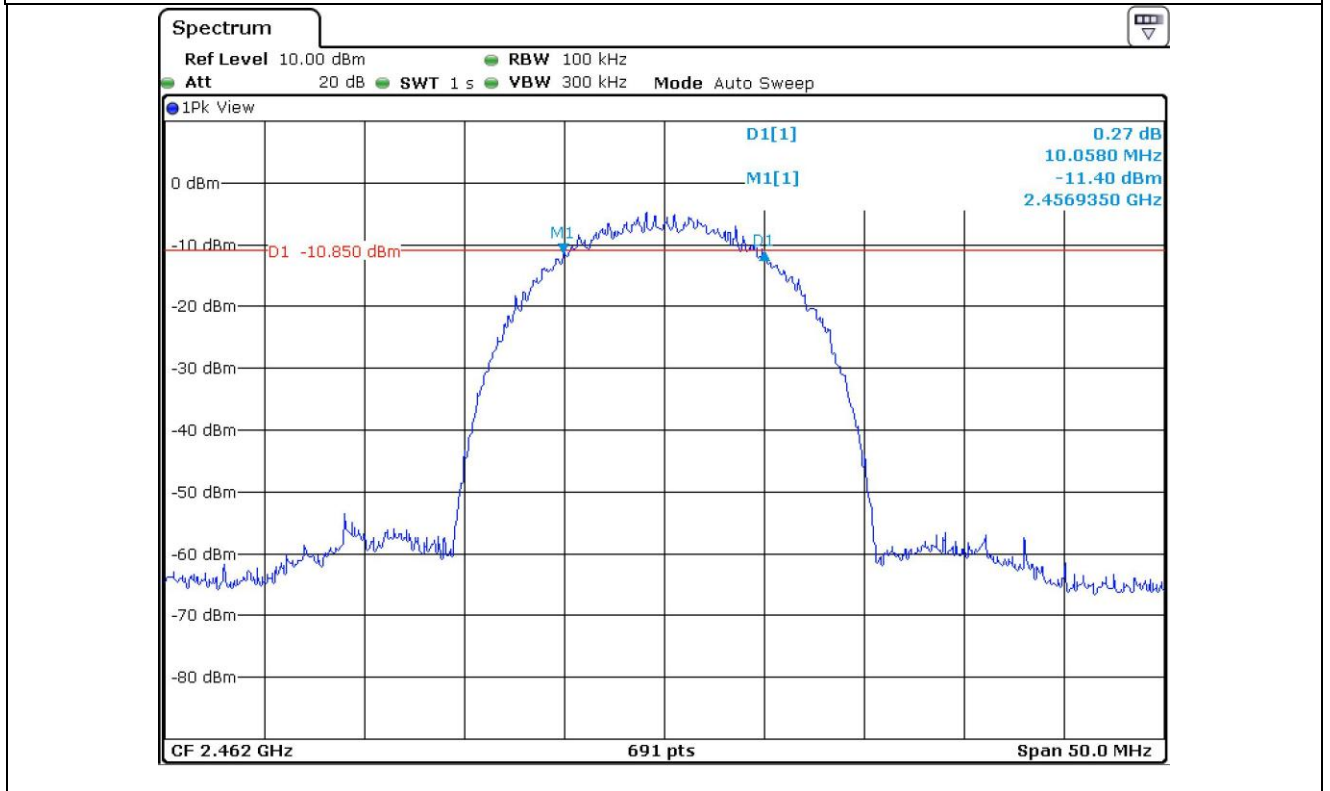

High Channel

7.5 Test data for 802.11g Mode

- Test Date : September 12, 2013
- Test Result : Pass

CHANNEL	FREQUENCY(MHz)	MEASURED VALUE (MHz)	LIMIT (MHz)	MARGIN (MHz)
Low	2 412	16.21	0.5	15.70
Middle	2 442	16.43	0.5	15.93
High	2 462	16.35	0.5	15.85

Remark. Margin = Measured Value - Limit



Tested by: Tae-Ho, Kim / Project Engineer

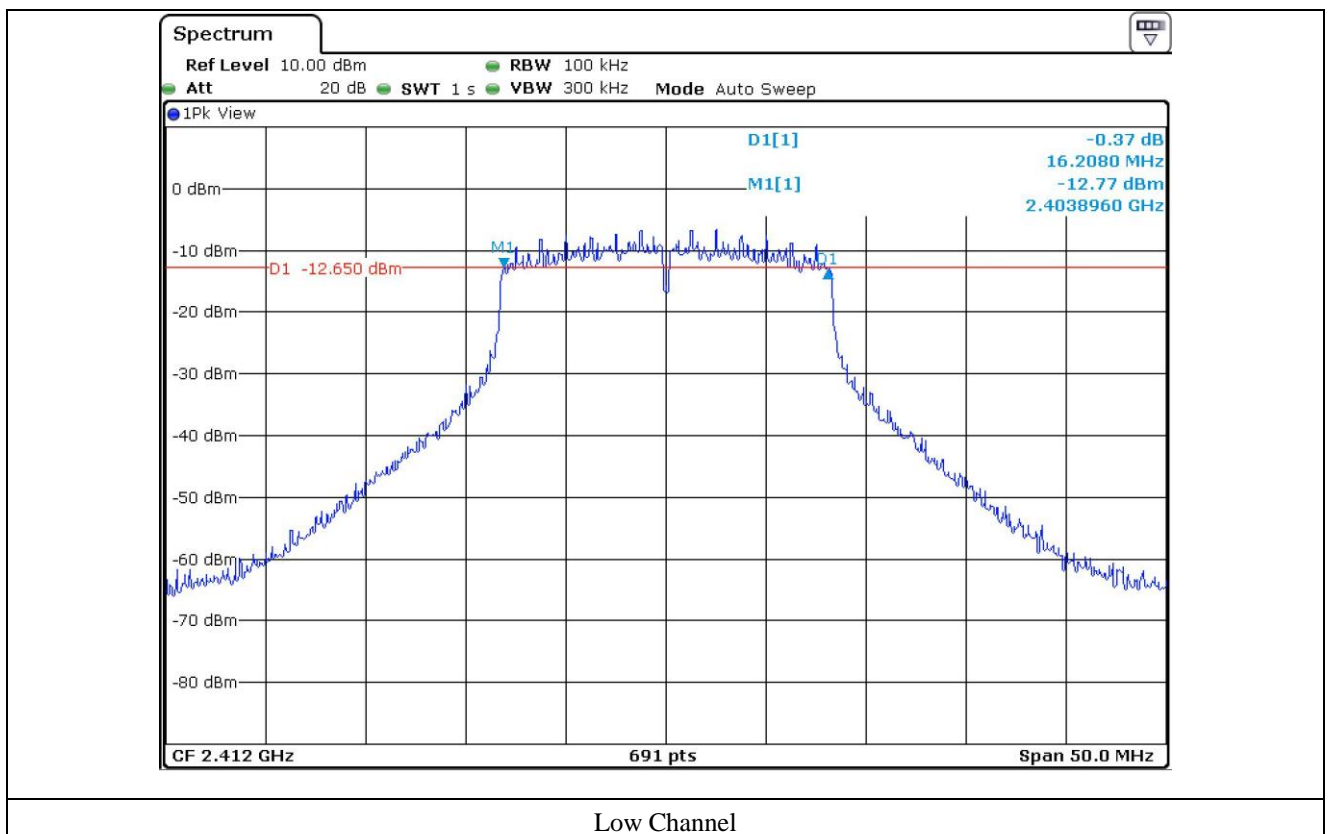

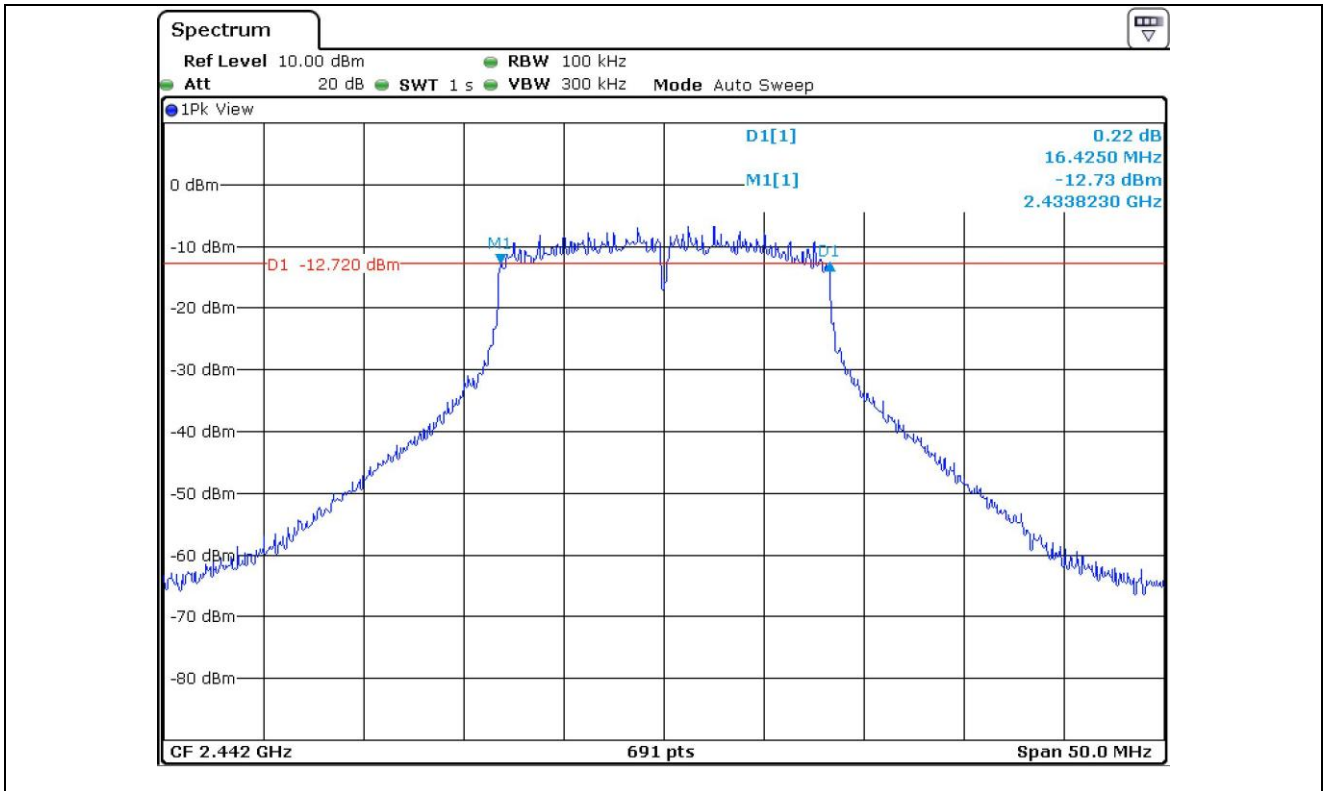

Middle Channel

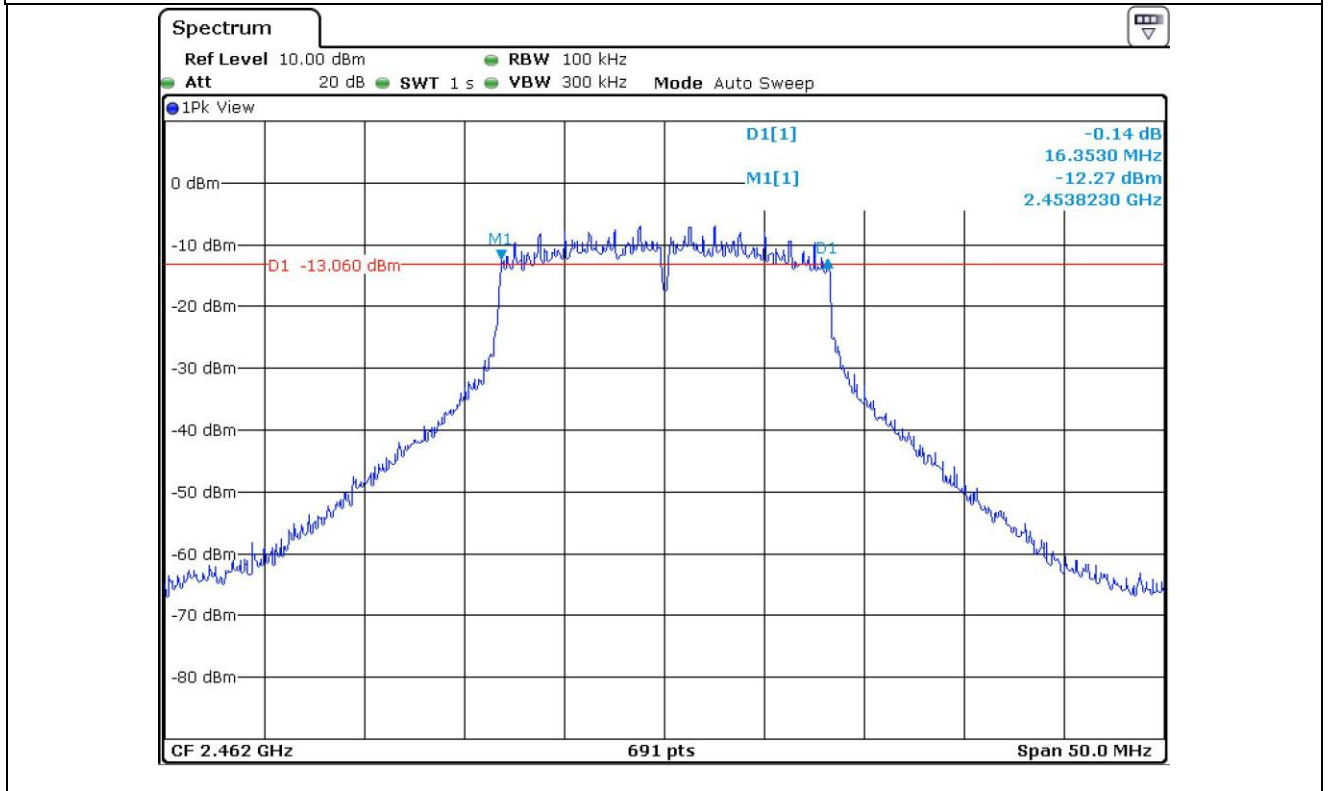

High Channel

7.6 Test data for 802.11n Mode

- Test Date : September 12, 2013
- Test Result : Pass

CHANNEL	FREQUENCY(MHz)	MEASURED VALUE (MHz)	LIMIT (MHz)	MARGIN (MHz)
Low	2 412	17.08	0.5	16.58
Middle	2 442	17.44	0.5	16.94
High	2 462	17.58	0.5	17.08

Remark. Margin = Measured Value - Limit



Tested by: Tae-Ho, Kim / Project Engineer

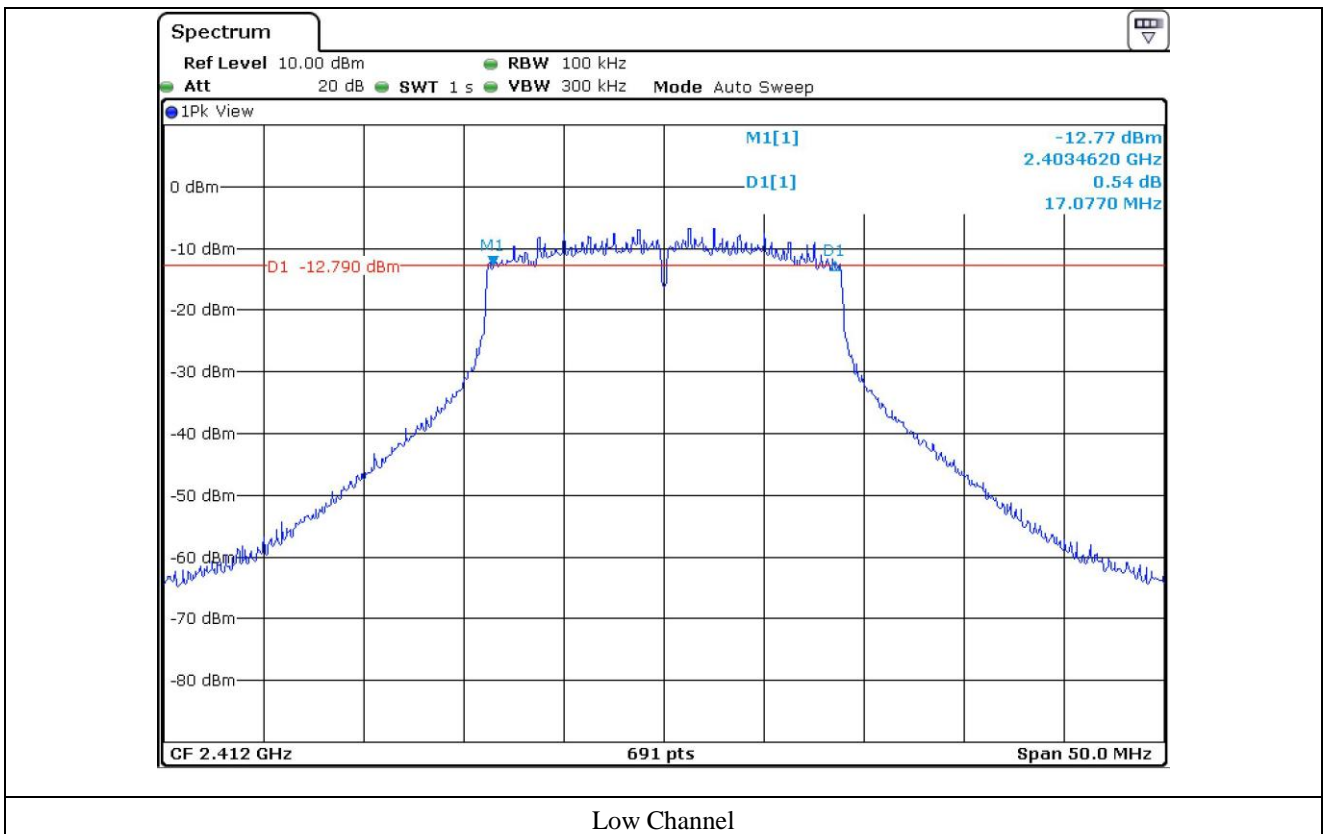

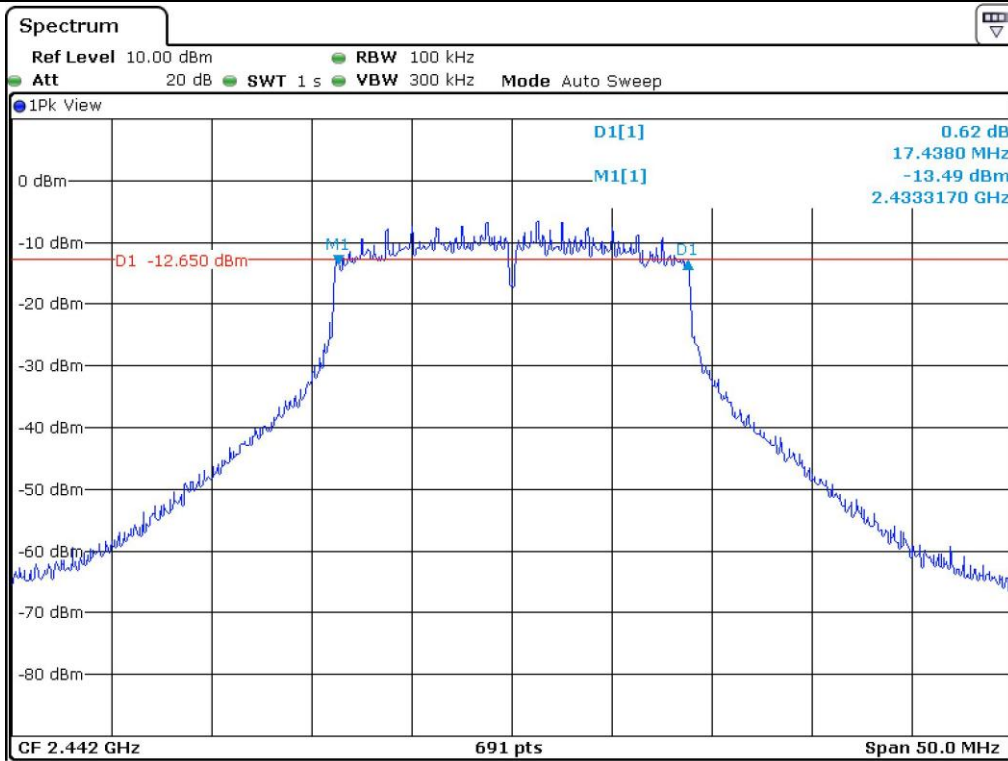

Middle Channel

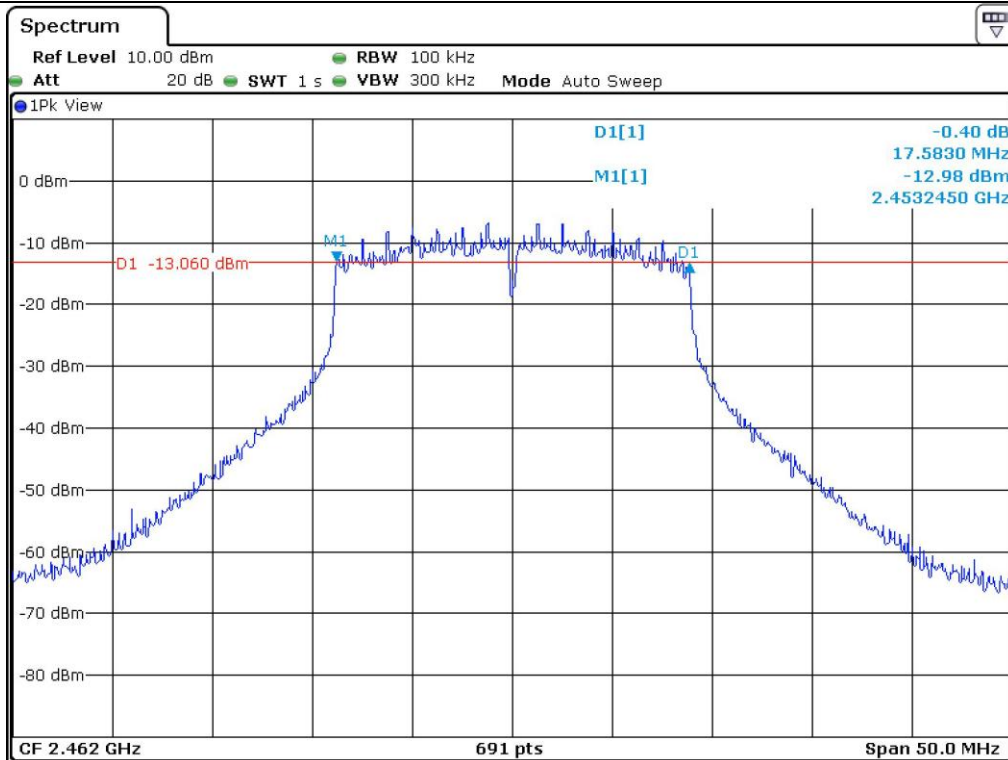

High Channel

8. MAXIMUM PEAK OUTPUT POWER

8.1 Operating environment

Temperature : 25 °C
Relative humidity : 40 % R.H.

8.2 Test set-up

The maximum peak output power was measured with the spectrum analyzer connected to the antenna output of the EUT. The spectrum analyzer's internal channel power integration function is used to integrate the power over a bandwidth greater than or equal to the DTS bandwidth. The EUT was operating in transmit mode at the appropriate center frequency.

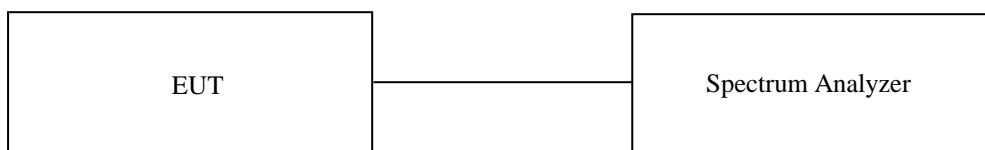

8.3 Test equipment used

Model Number	Manufacturer	Description	Serial Number	Last Cal.
■ - FSV30	R/S	Spectrum Analyzer	101372	May 30, 2013

All test equipment used is calibrated on a regular basis.

8.4 Test data for 802.11b Mode

- Test Date : September 13, 2013
- Test Result : Pass

CHANNEL	FREQUENCY (MHz)	DTS (MHz)	MEASURED VLAUE (dBm)	LIMIT (dBm)	MARGIN (dB)
LOW	2 412	9.91	3.49	30	26.51
MIDDLE	2 442	9.55	3.56	30	26.44
HIGH	2 462	10.06	3.49	30	26.44

Remark. Margin = Limit – Measured Value (=Receiver Reading + Cable Loss)



Tested by: Tae-Ho, Kim / Project Engineer

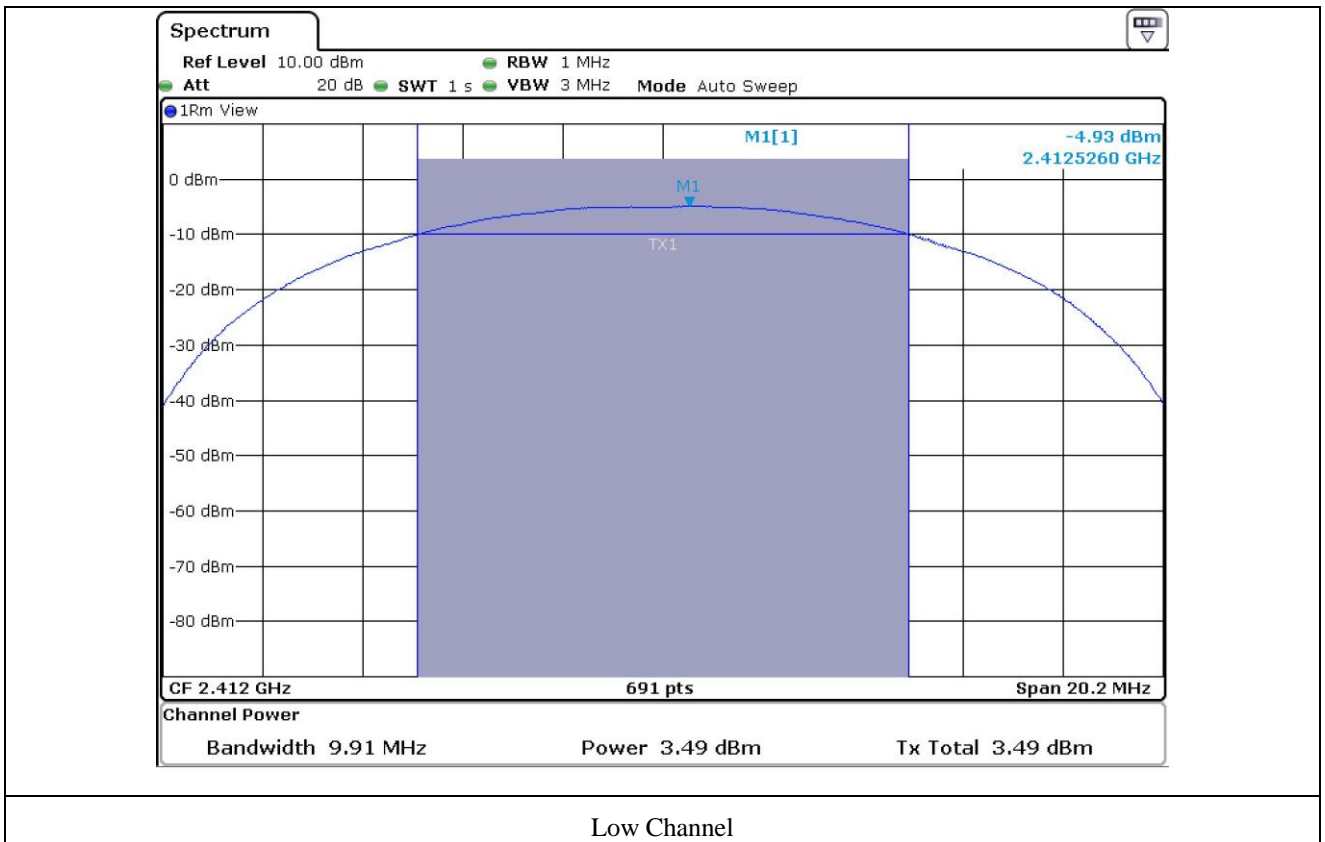

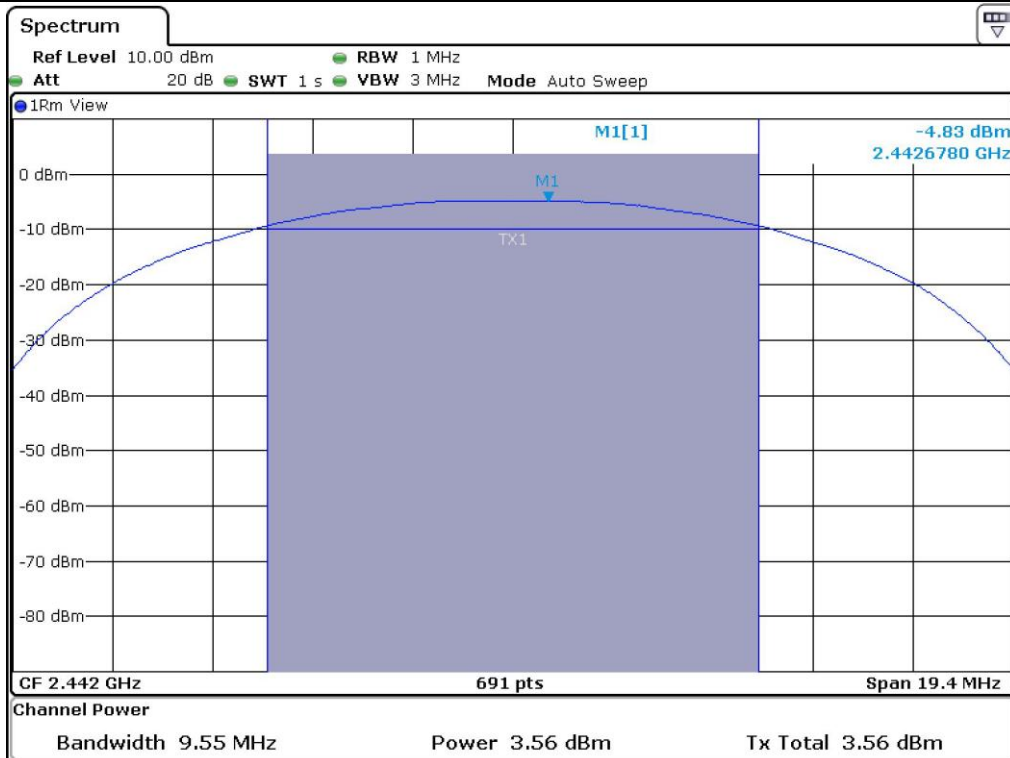

Middle Channel

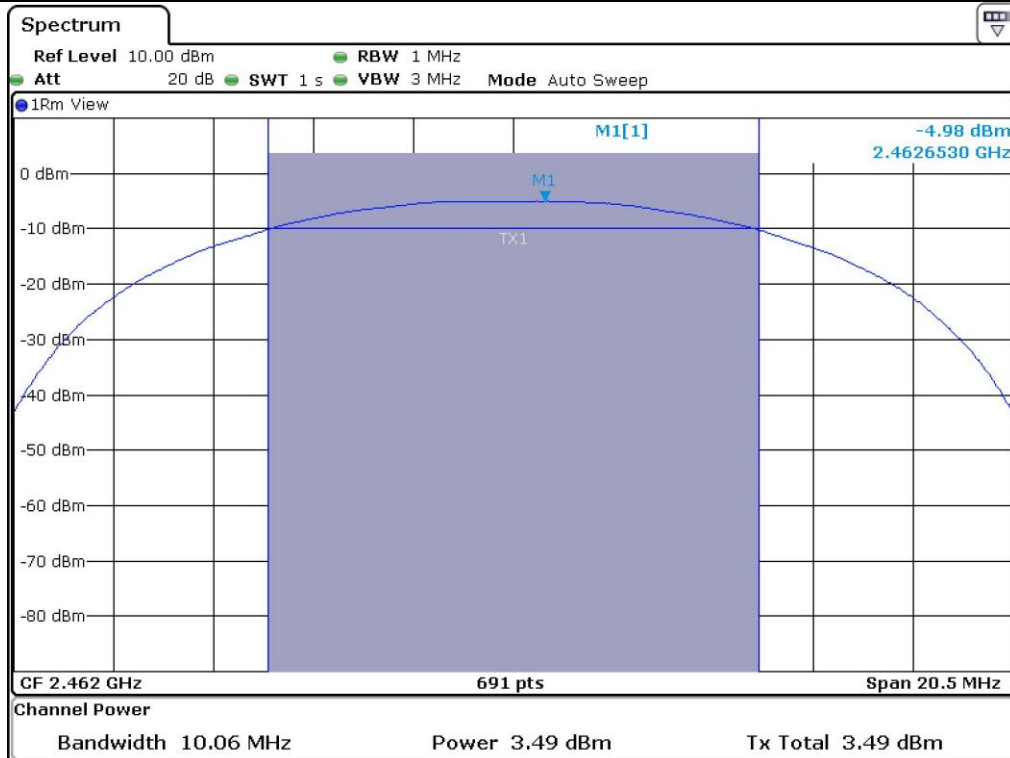

High Channel

8.5 Test data for 802.11g Mode

-. Test Date : September 13, 2013
-. Test Result : Pass

CHANNEL	FREQUENCY (MHz)	DTS (MHz)	MEASURED VLAUE (dBm)	LIMIT (dBm)	MARGIN (dB)
LOW	2 412	16.21	2.74	30	27.26
MIDDLE	2 442	16.43	2.87	30	27.13
HIGH	2 462	16.35	2.57	30	27.43

Remark. Margin = Limit – Measured Value (=Receiver Reading + Cable Loss)



Tested by: Tae-Ho, Kim / Project Engineer

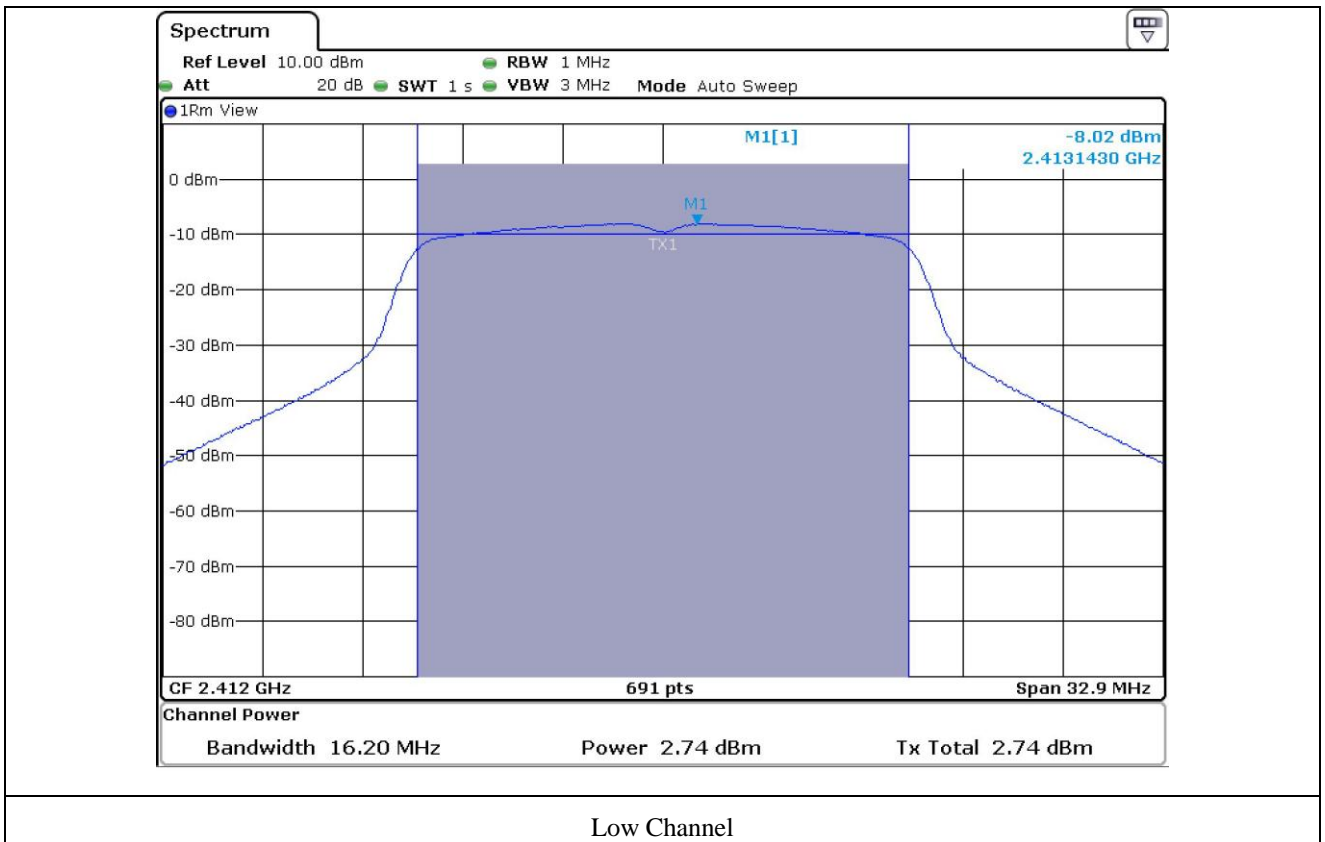

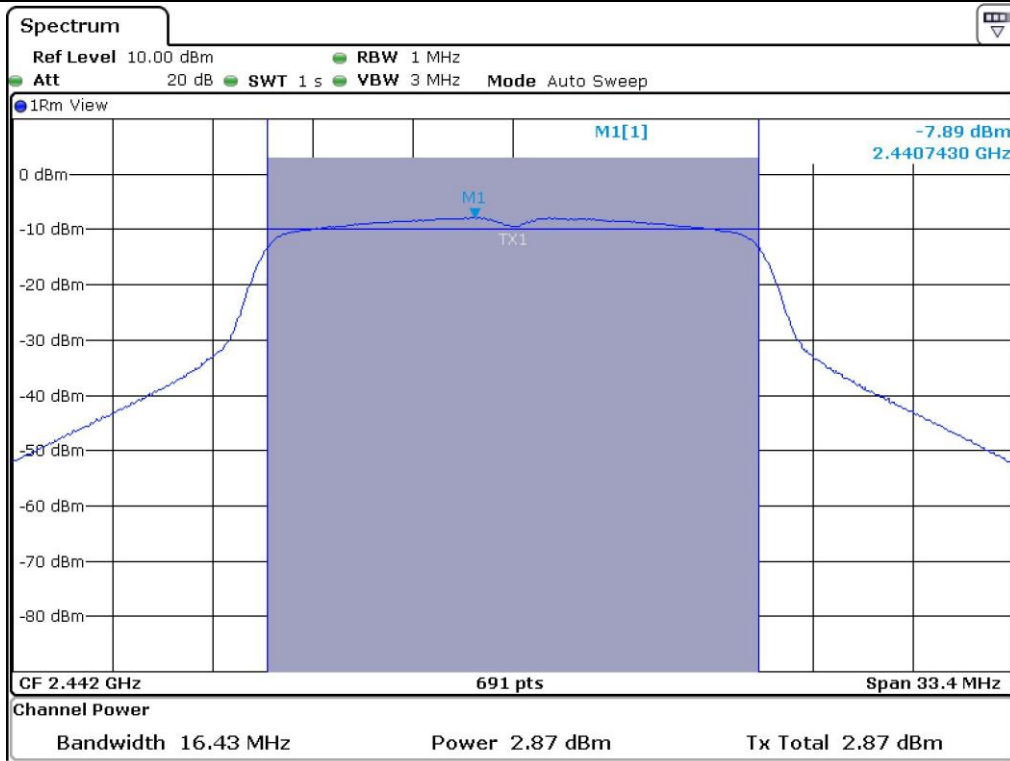

Middle Channel

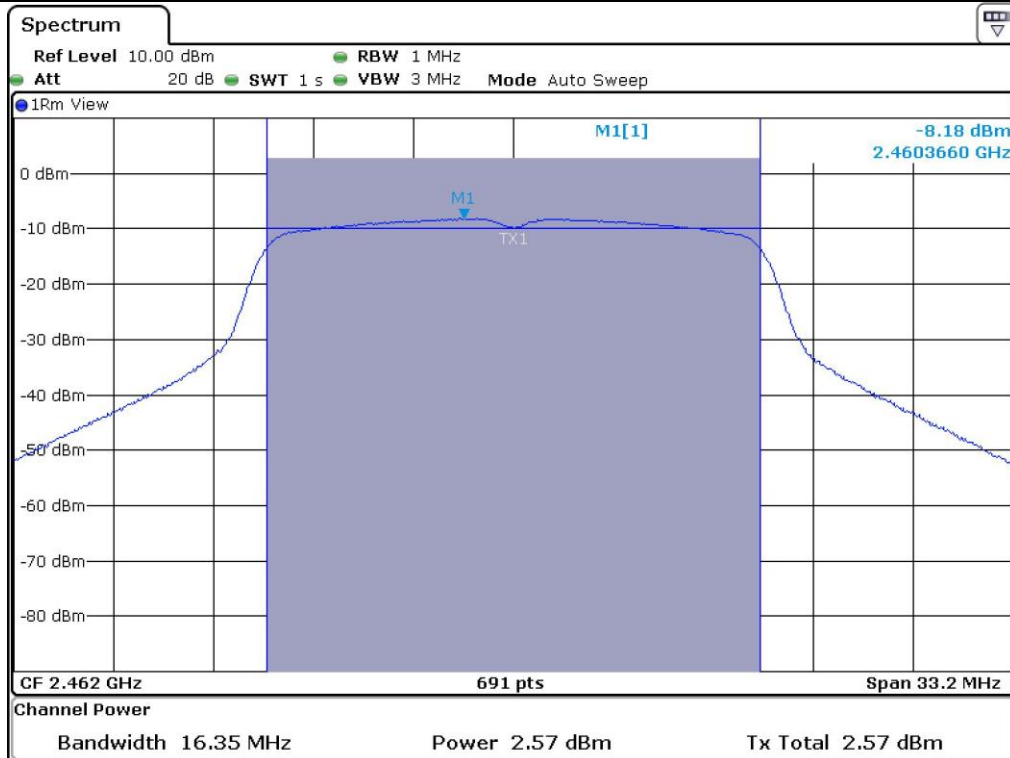

High Channel

8.6 Test data for 802.11n Mode

- Test Date : September 13, 2013
- Test Result : Pass

CHANNEL	FREQUENCY (MHz)	DTS (MHz)	MEASURED VLAUE (dBm)	LIMIT (dBm)	MARGIN (dB)
LOW	2 412	17.08	2.70	30	27.30
MIDDLE	2 442	17.44	2.88	30	27.12
HIGH	2 462	17.58	2.61	30	27.39

Remark. Margin = Limit – Measured Value (=Receiver Reading + Cable Loss)



Tested by: Tae-Ho, Kim / Project Engineer

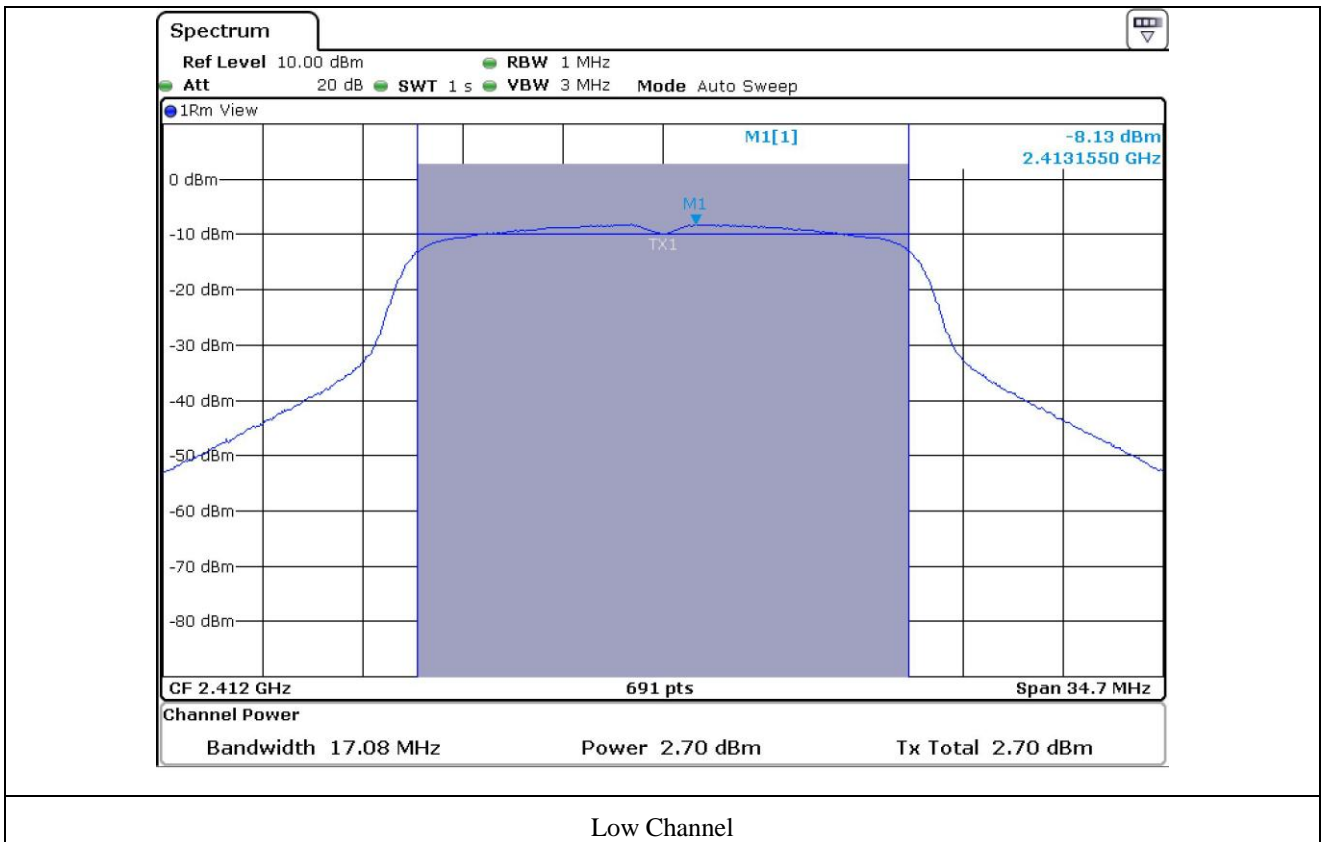

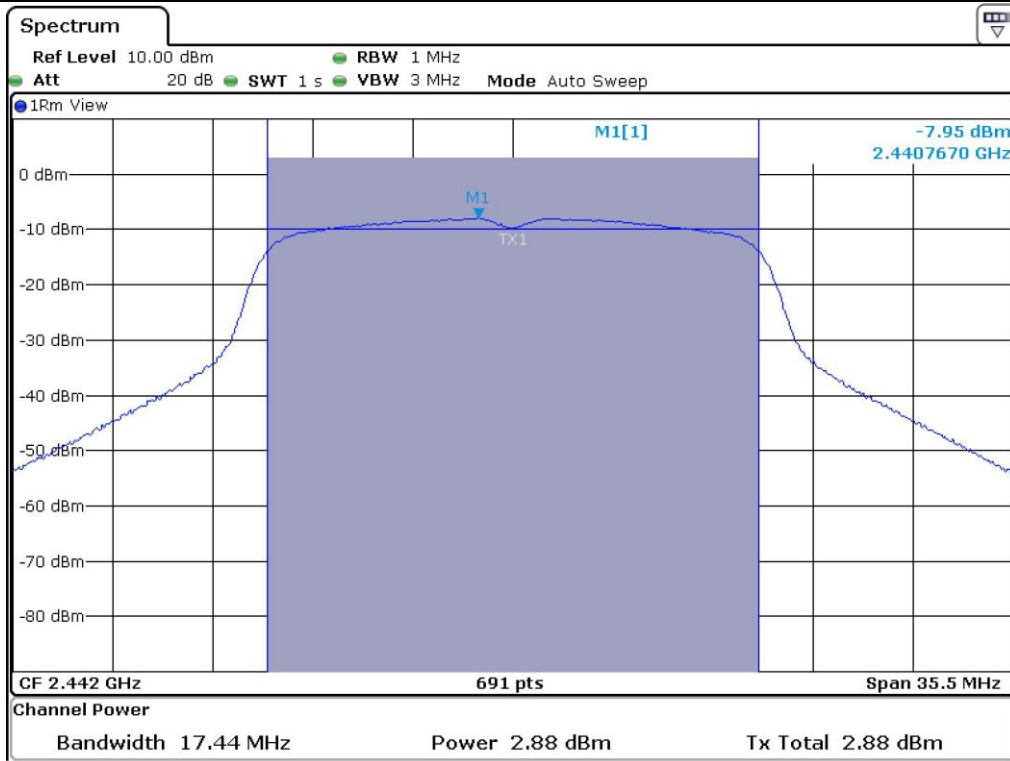

Middle Channel

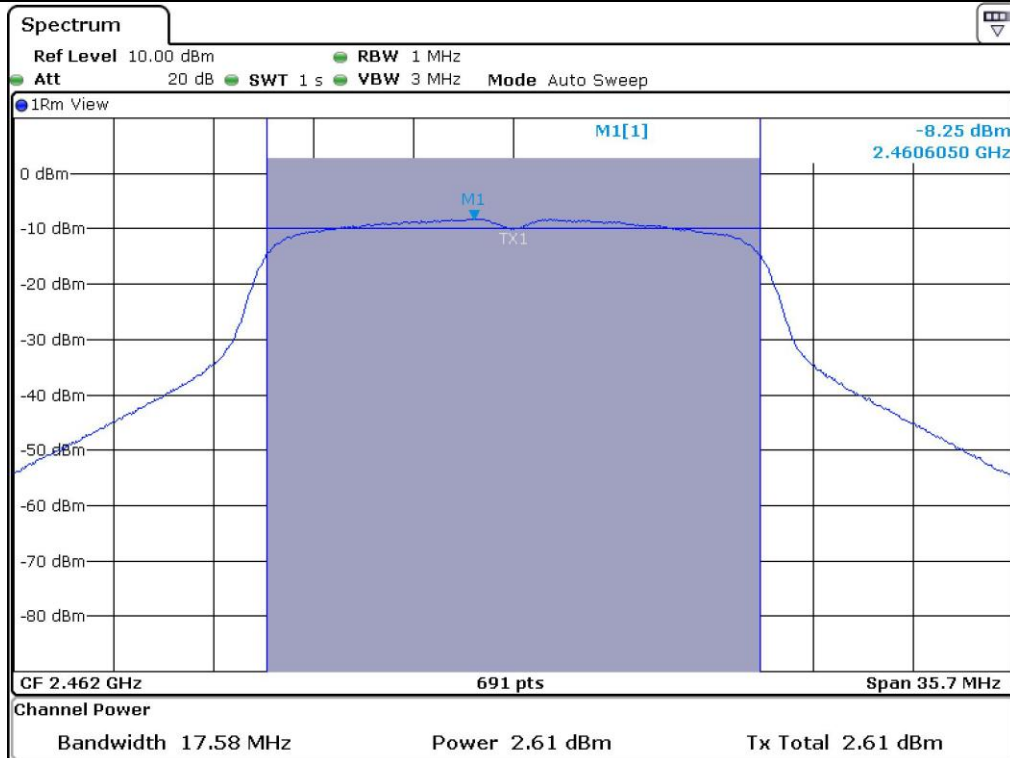

High Channel

9. 100 kHz BANDWIDTH OUTSIDE THE FREQUENCY BAND

9.1 Operating environment

Temperature : 28 °C
Relative humidity : 45 % R.H.

9.2 Test set-up for conducted measurement

The antenna output of the EUT was connected to the spectrum analyzer. The resolution and video bandwidth is set to 100 kHz, and peak detection was used.

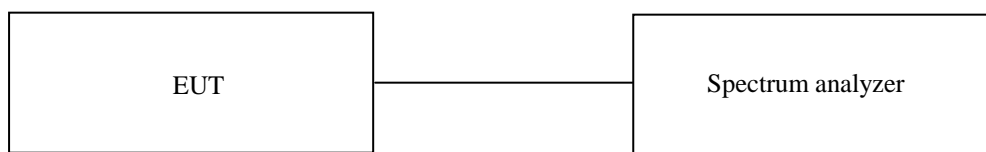

9.3 Test set-up for radiated measurement

The radiated emissions measurements were performed on the 3 m, open-field test site. The EUT was placed on a non-conductive turntable approximately 0.8 m above the ground plane.

The frequency spectrum from 30 MHz to 26.5 GHz was scanned and maximum emission levels at each frequency recorded. The system was rotated 360°, and the antenna was varied in the height between 1.0 m and 4.0 m in order to determine the maximum emission levels. This procedure was performed for horizontal and vertical polarization of the receiving antenna.

9.4 Test equipment used

	Model Number	Manufacturer	Description	Serial Number	Last Cal.(Interval)
■ -	8564E	HP	Spectrum Analyzer	3650A00756	May 03, 2013(1Y)
■ -	ESU	Rohde & Schwarz	EMI Test Receiver	100261	May 27, 2013(1Y)
■ -	310N	Sonoma Instrument	AMPLIFIER	312544	May 21, 2013(1Y)
■ -	FSV30	Rohde & Schwarz	Signal Analyzer	101372	May 20, 2013(1Y)
■ -	SCU-18	Rohde & Schwarz	PRE-AMPLIFIER	10041	Jan. 25, 2013(1Y)
■ -	MA220	HD	Turn Table	N/A	N/A
■ -	HD240	HD	Antenna Mast	N/A	N/A
■ -	VULB9163	Schwarzbeck	TRILOG Broadband Antenna	VULB9163-255	Apr. 24, 2012(2Y)
■ -	BBHA9120D	Schwarzbeck	Horn Antenna	BBHA9120D294	Jun. 17, 2013 (2Y)
■ -	BBHA9170	Schwarzbeck	Horn Antenna	BBHA9170178	Jun. 17, 2013 (2Y)

All test equipment used is calibrated on a regular basis.

9.5 Test data for conducted emission

9.5.1 Test data for 802.11b Mode

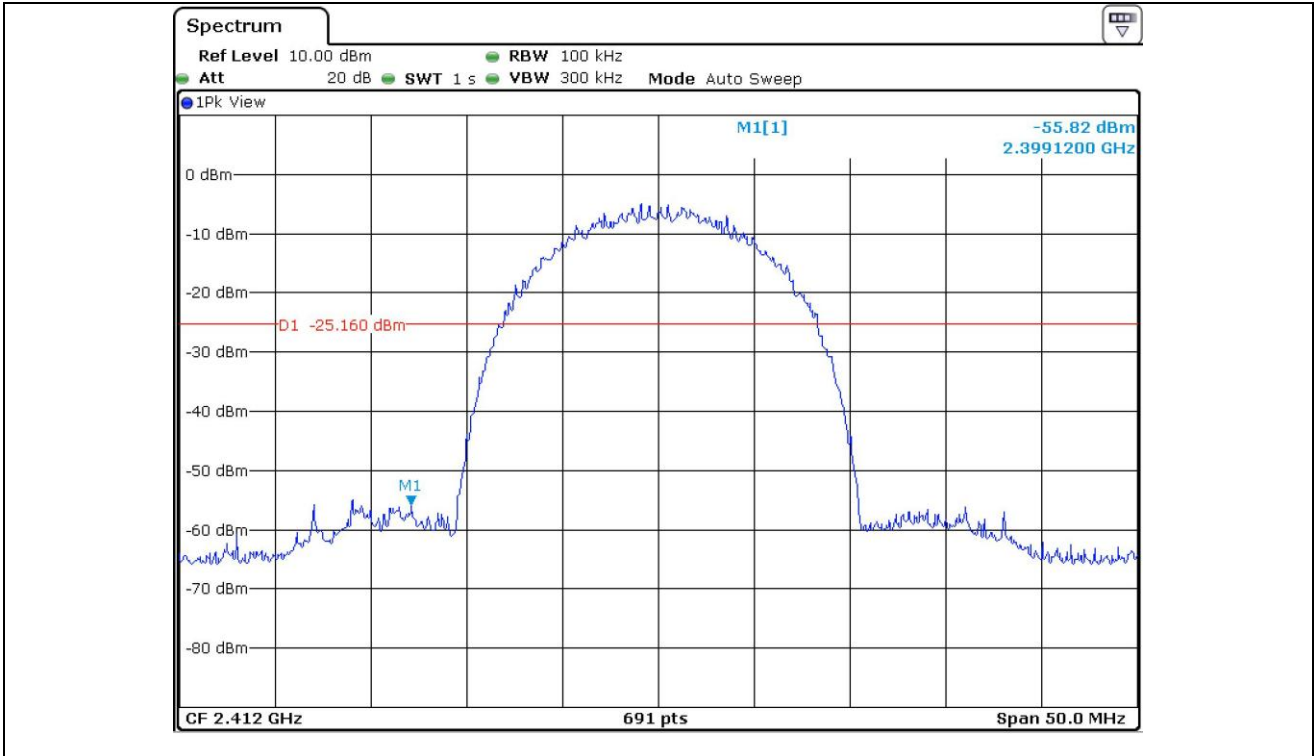

Low Channel

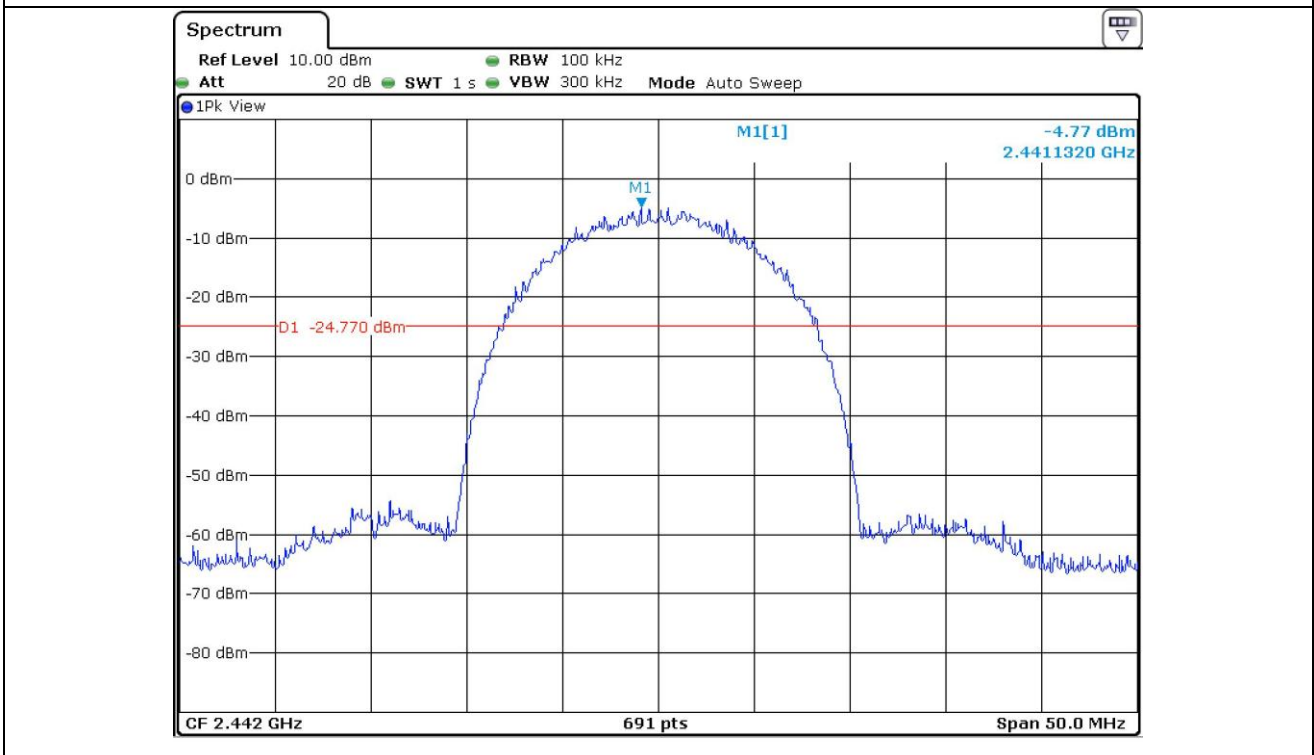

Middle Channel

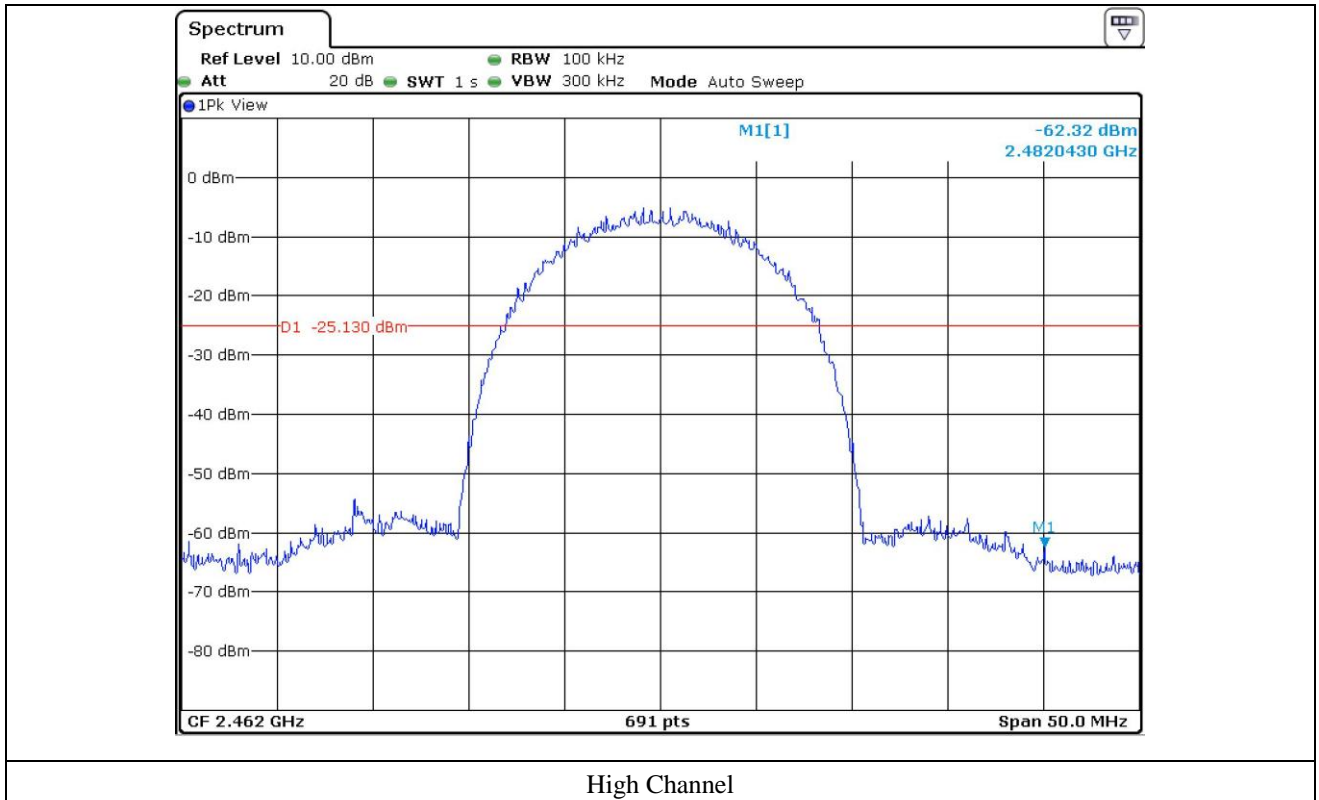

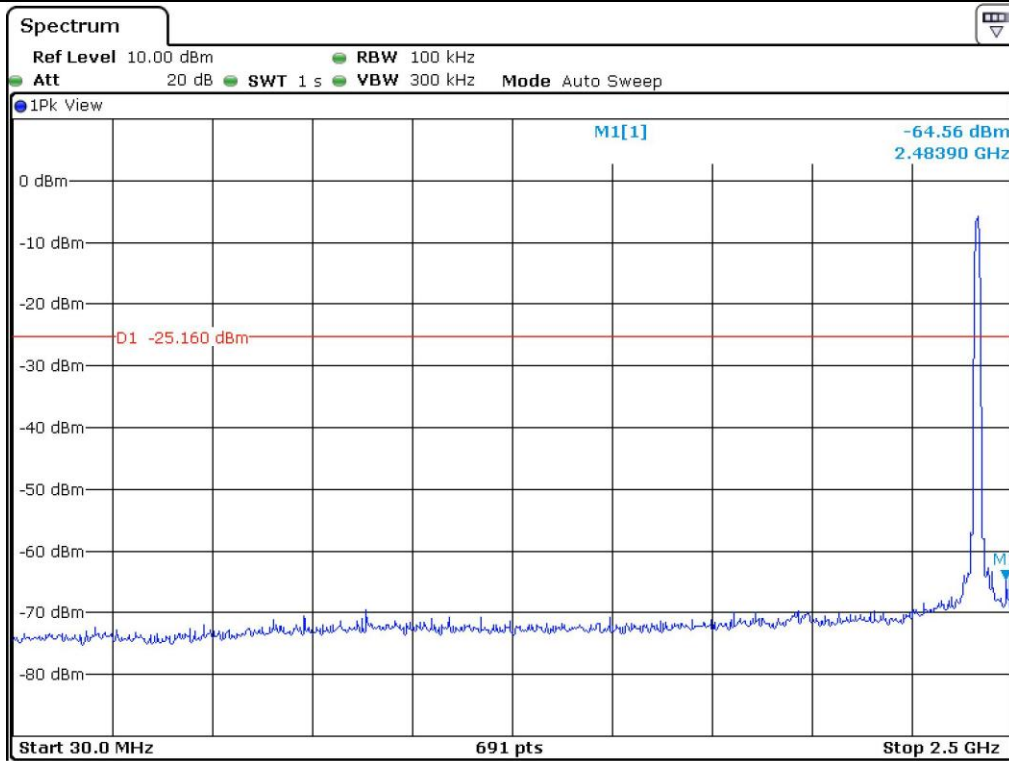

Low Channel

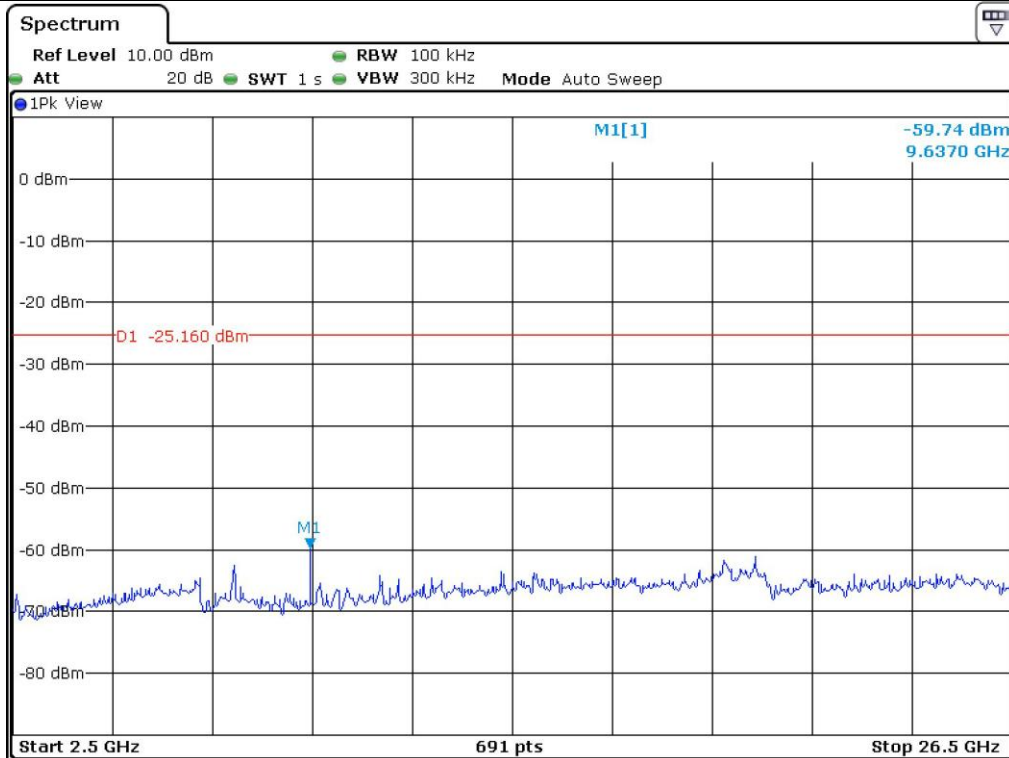

Low Channel

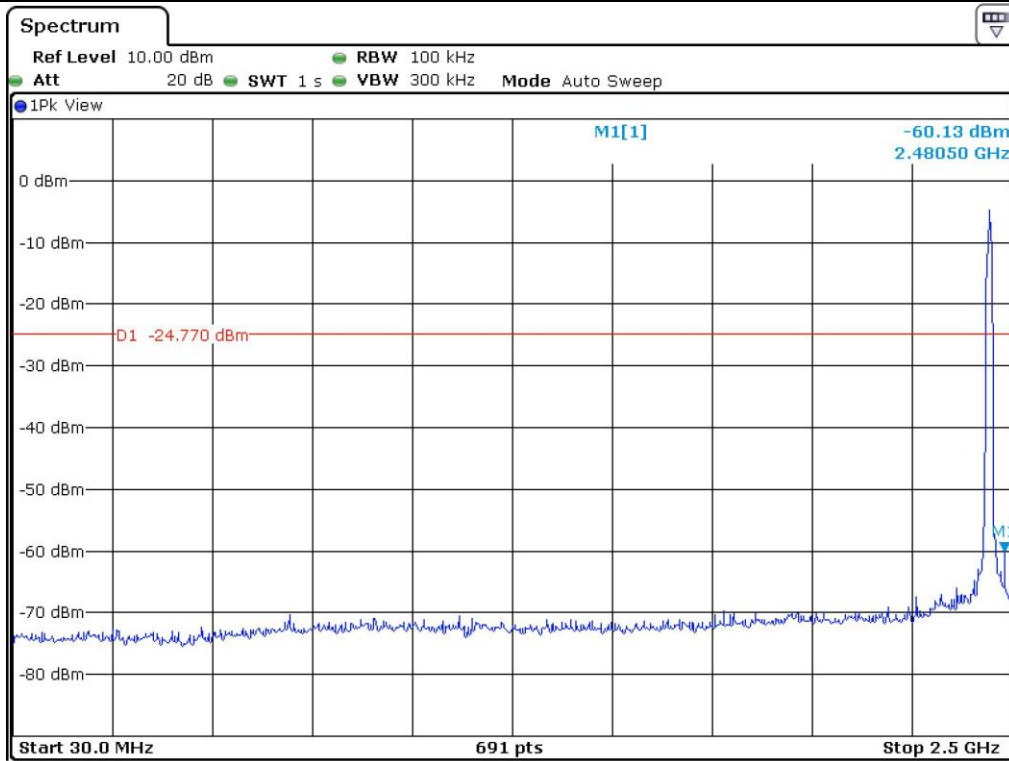

Middle Channel

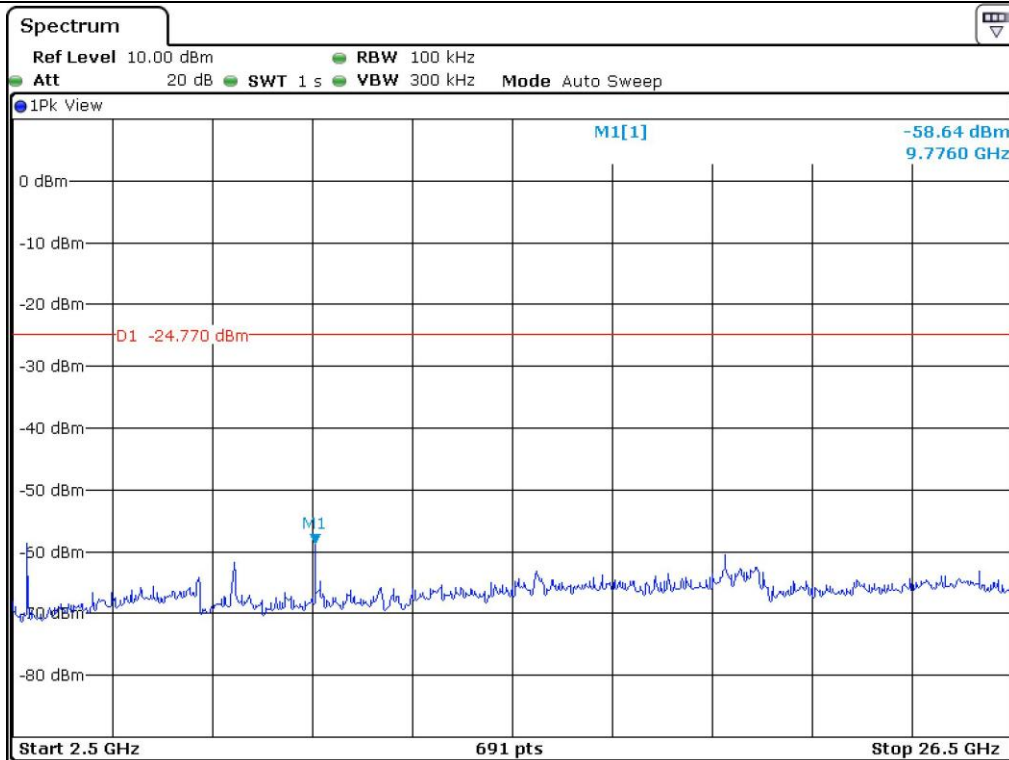

Middle Channel

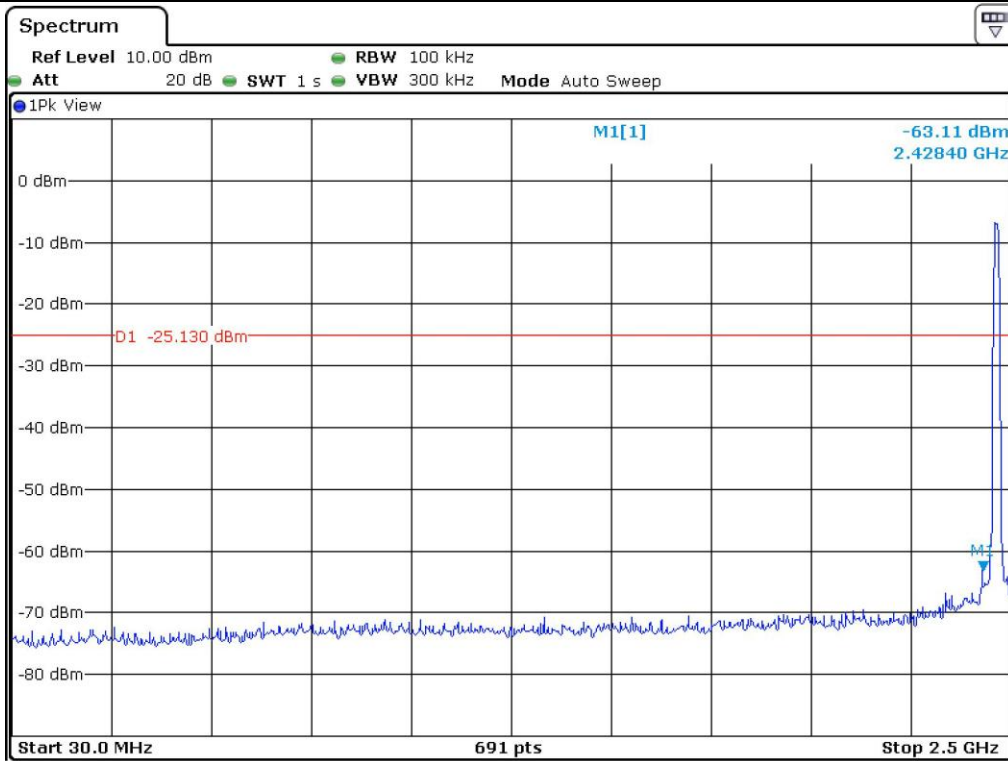

High Channel

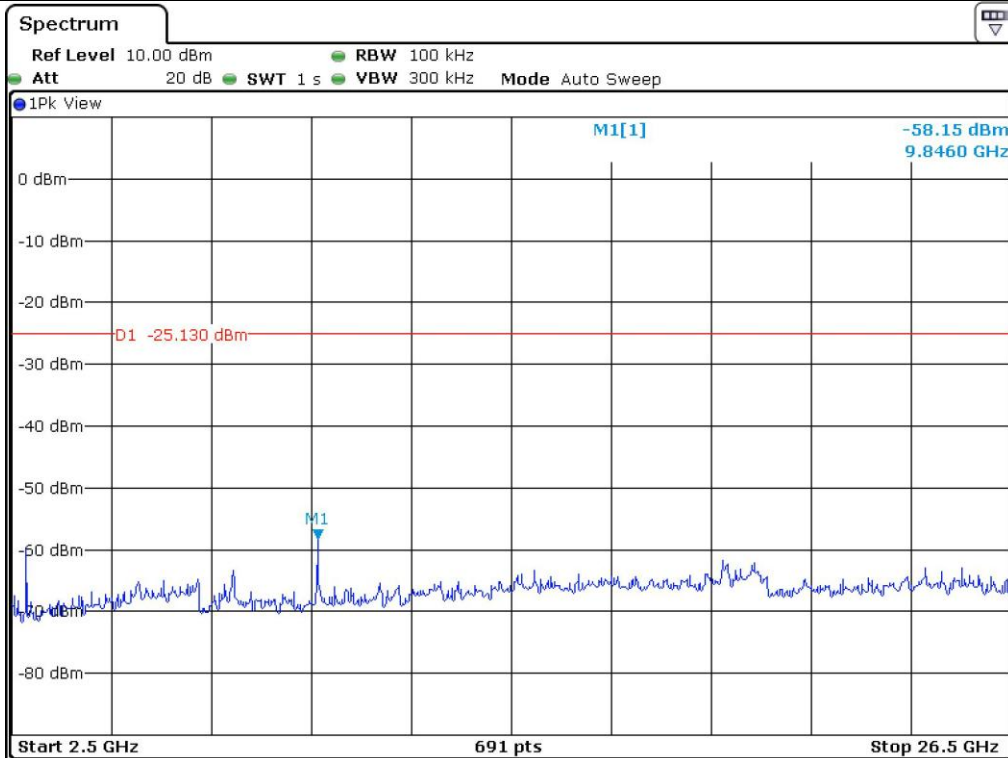

High Channel

9.5.2 Test data for 802.11g Mode

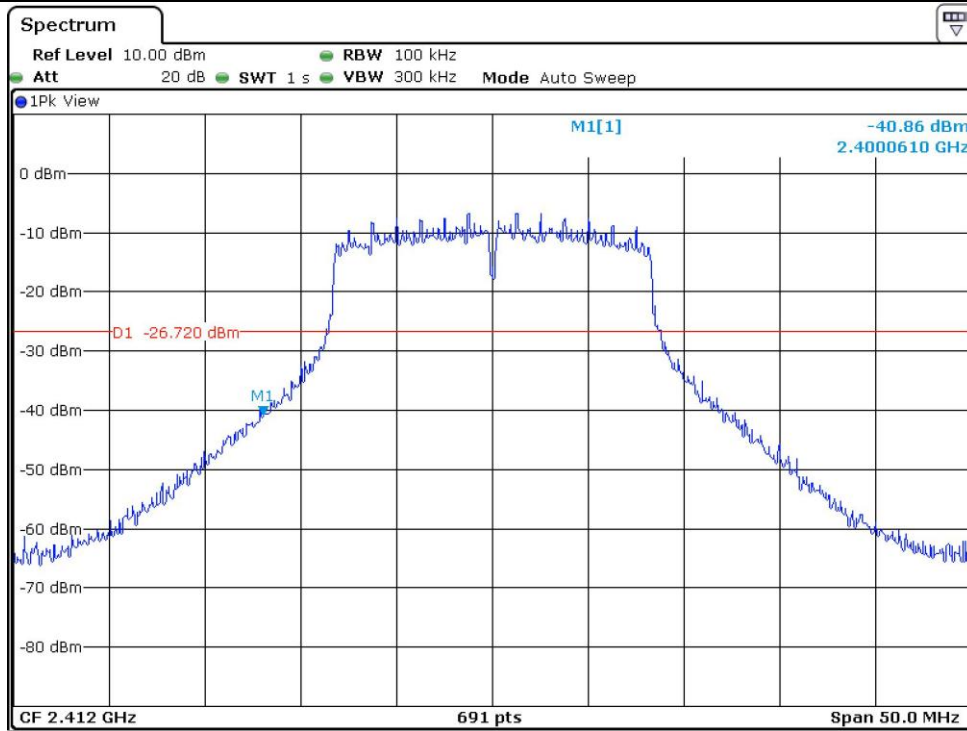

Low Channel

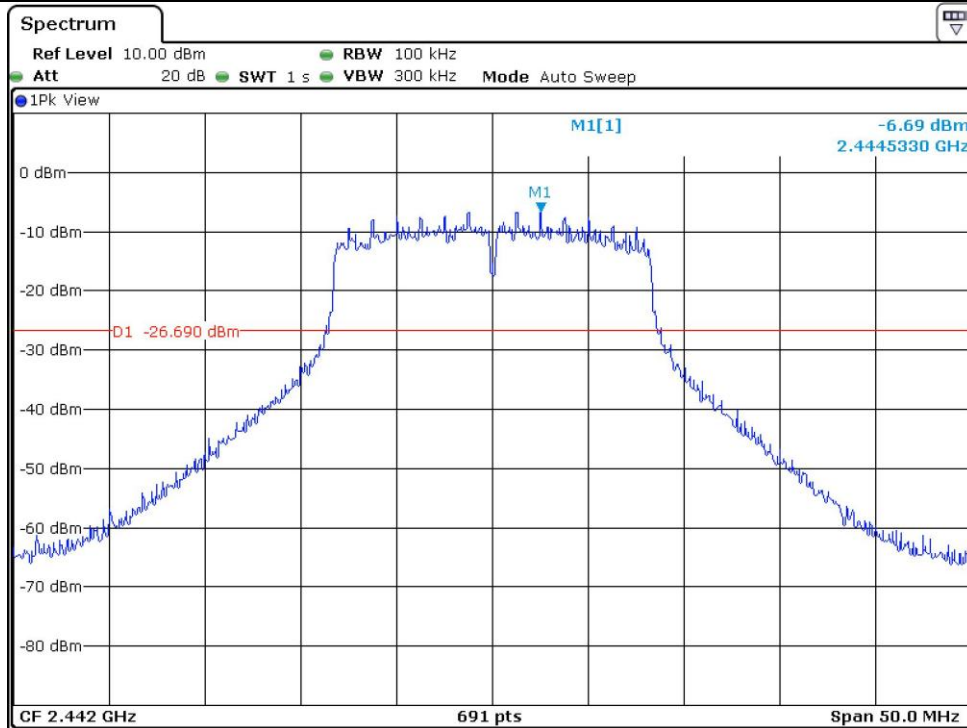

Middle Channel

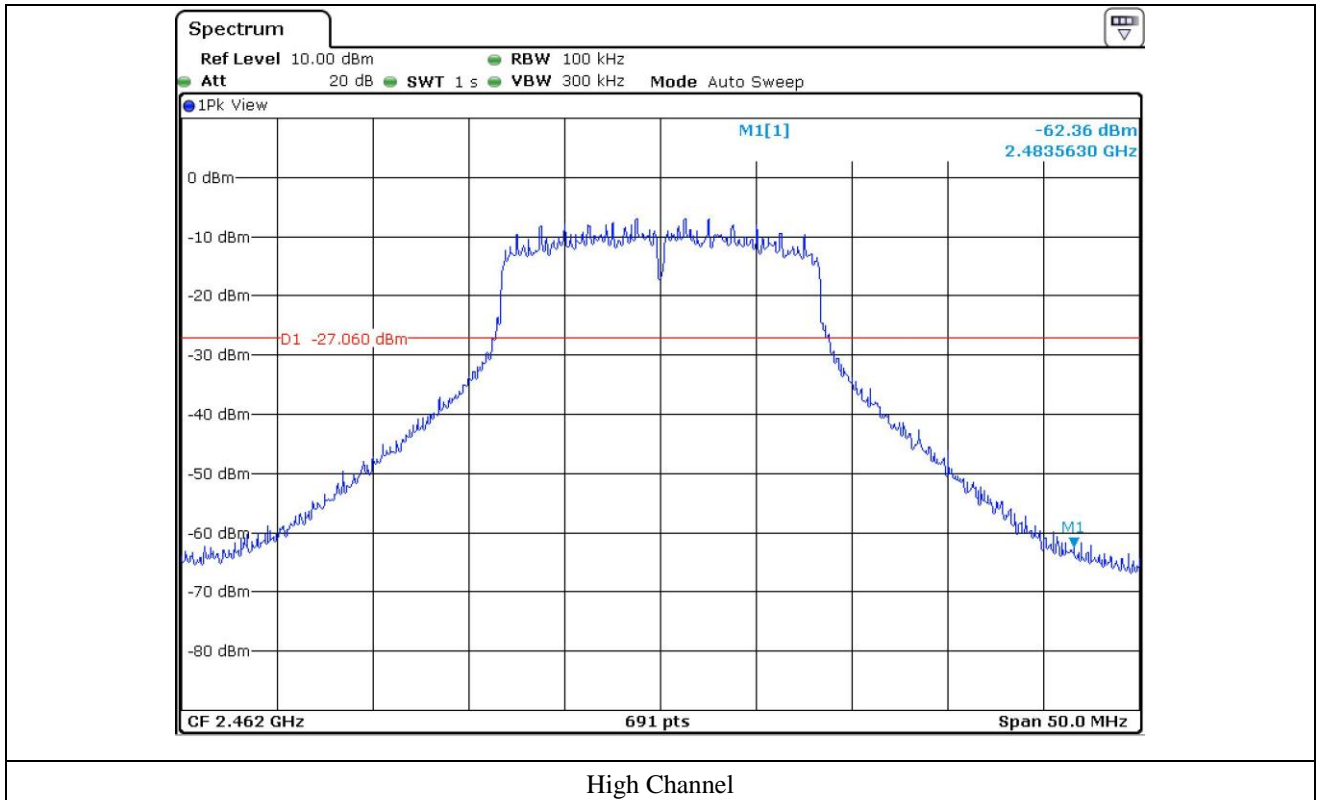

High Channel

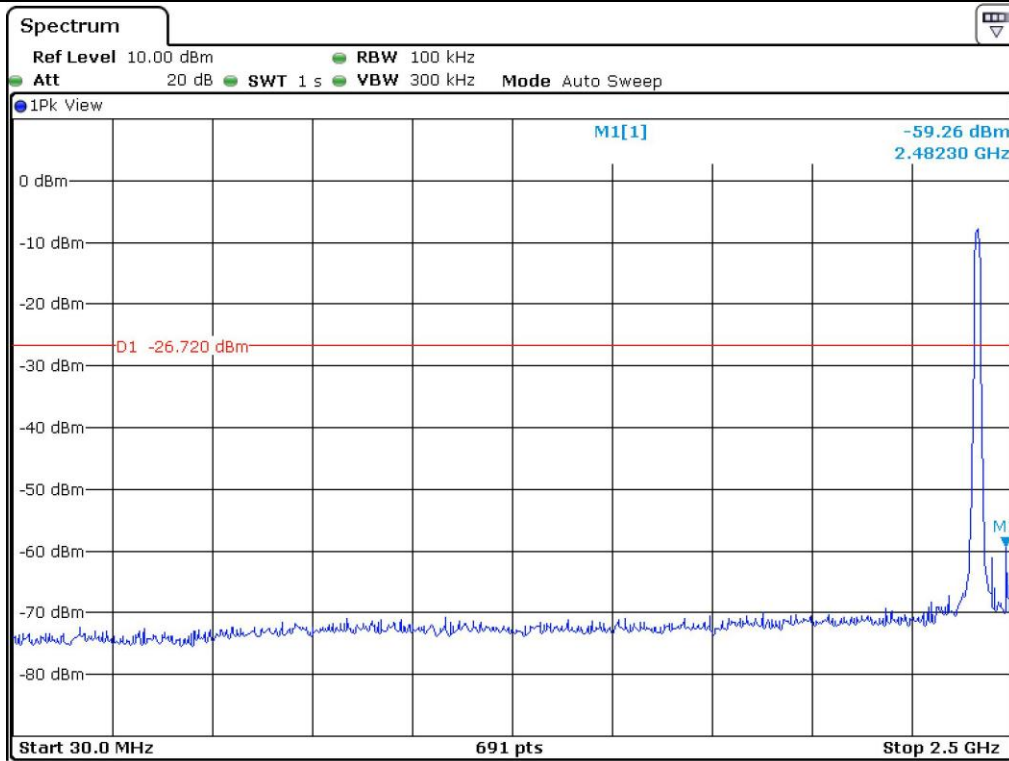

Low Channel

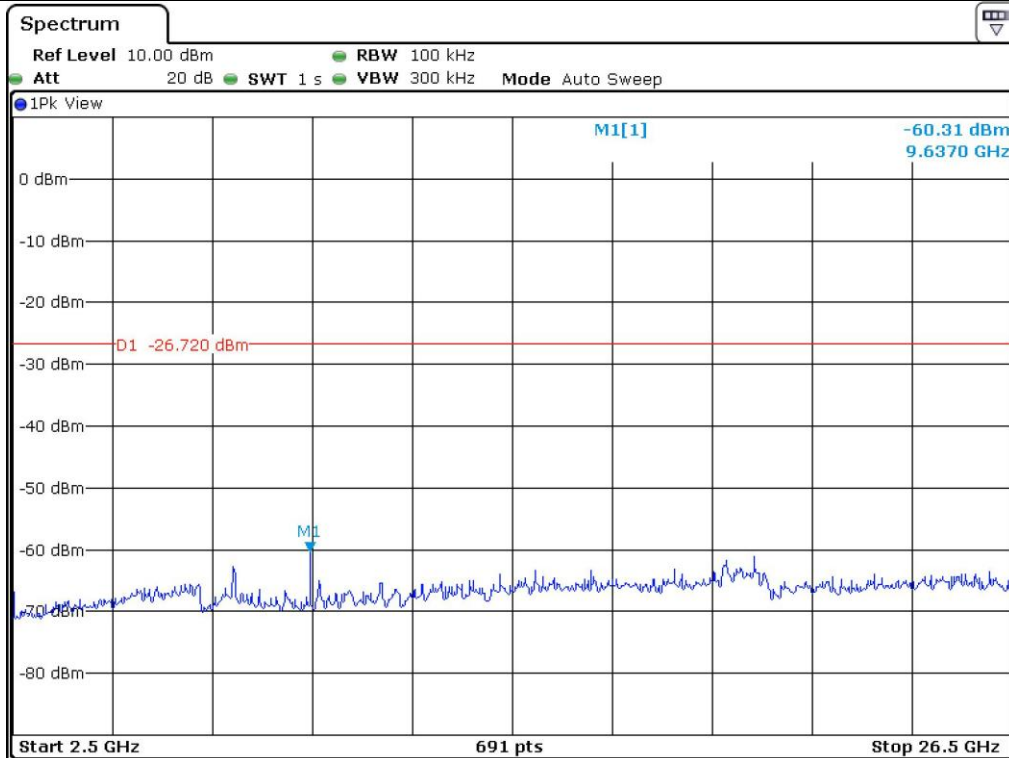

Low Channel

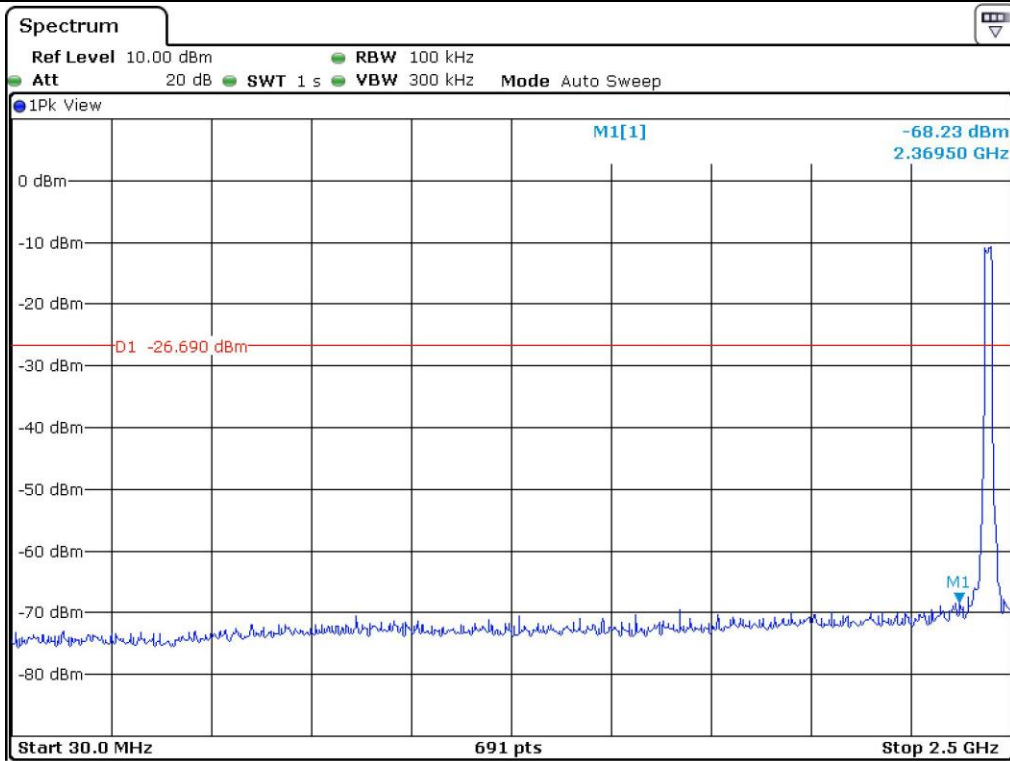

Middle Channel

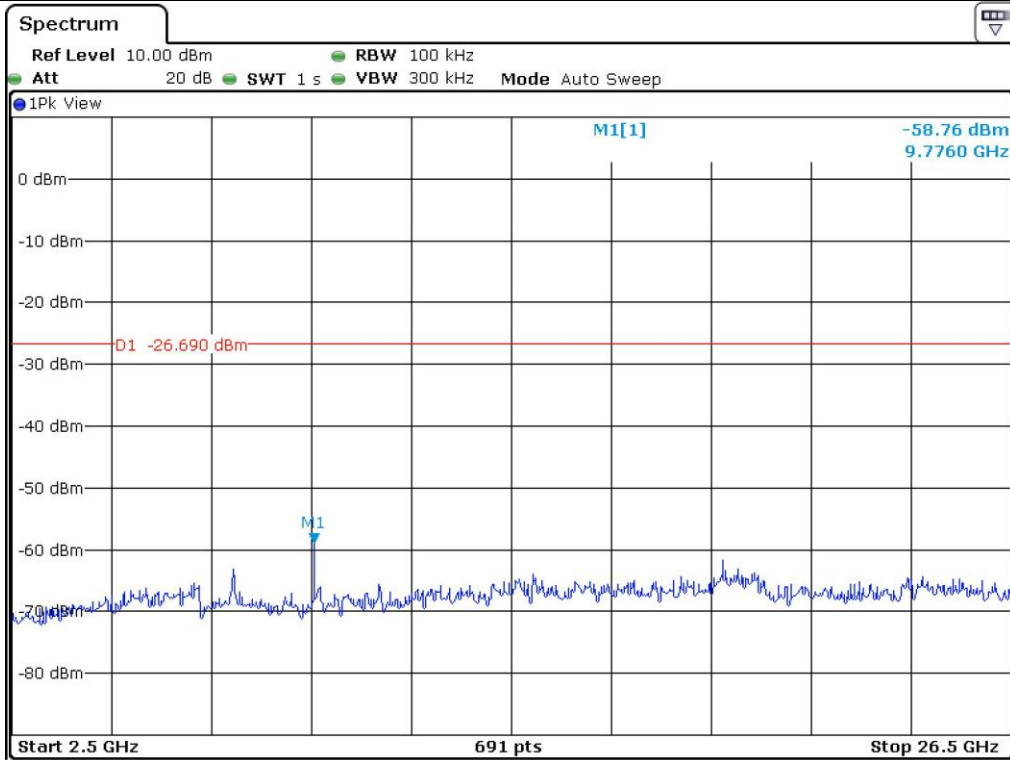

Middle Channel

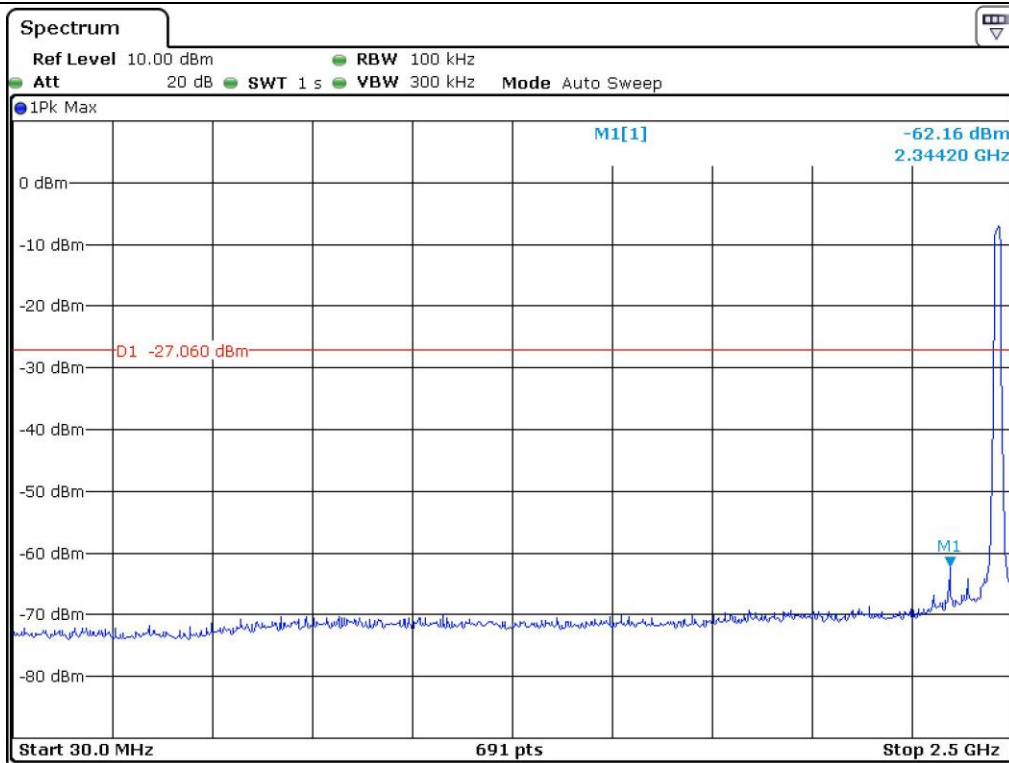

High Channel

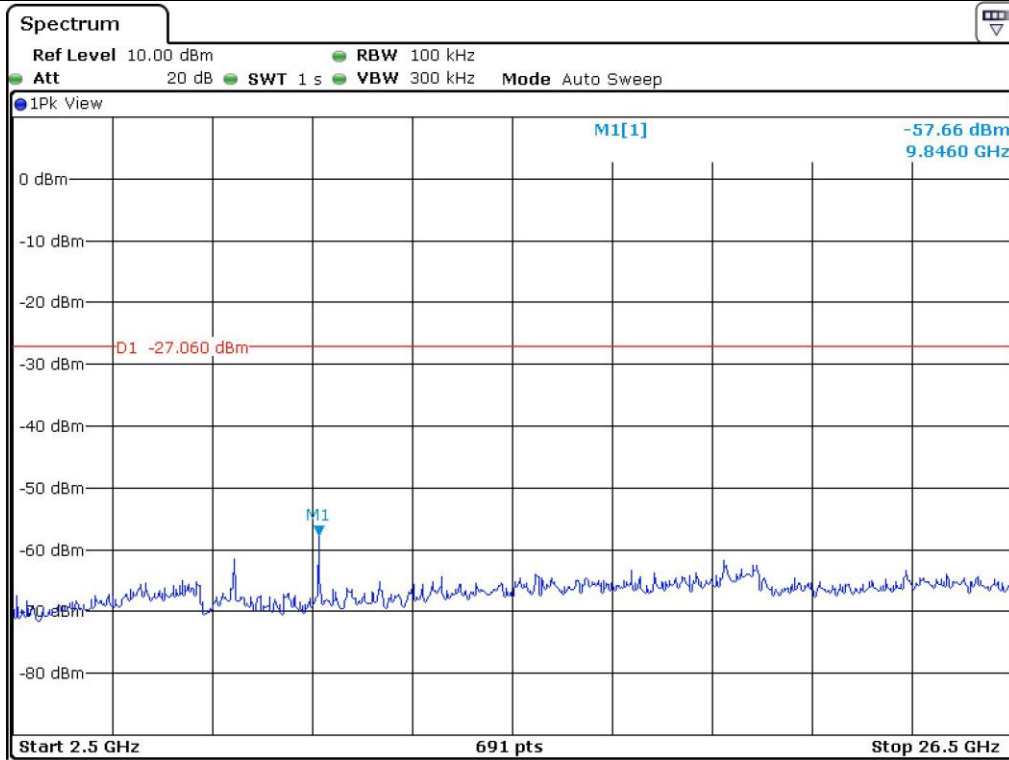

High Channel

9.5.3 Test data for 802.11n Mode

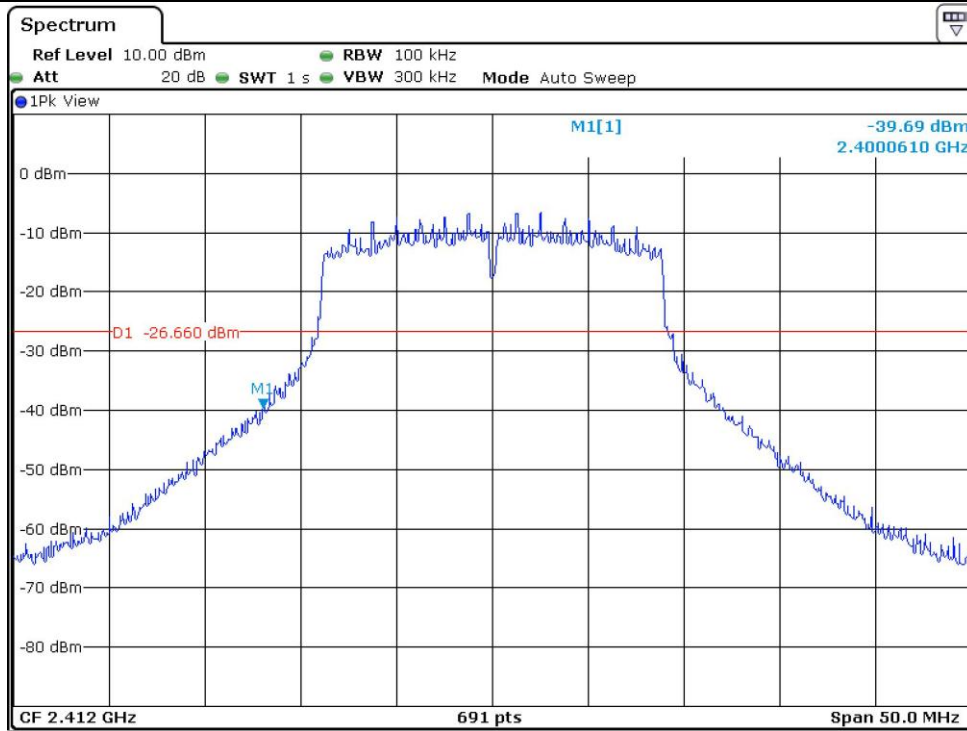

Low Channel

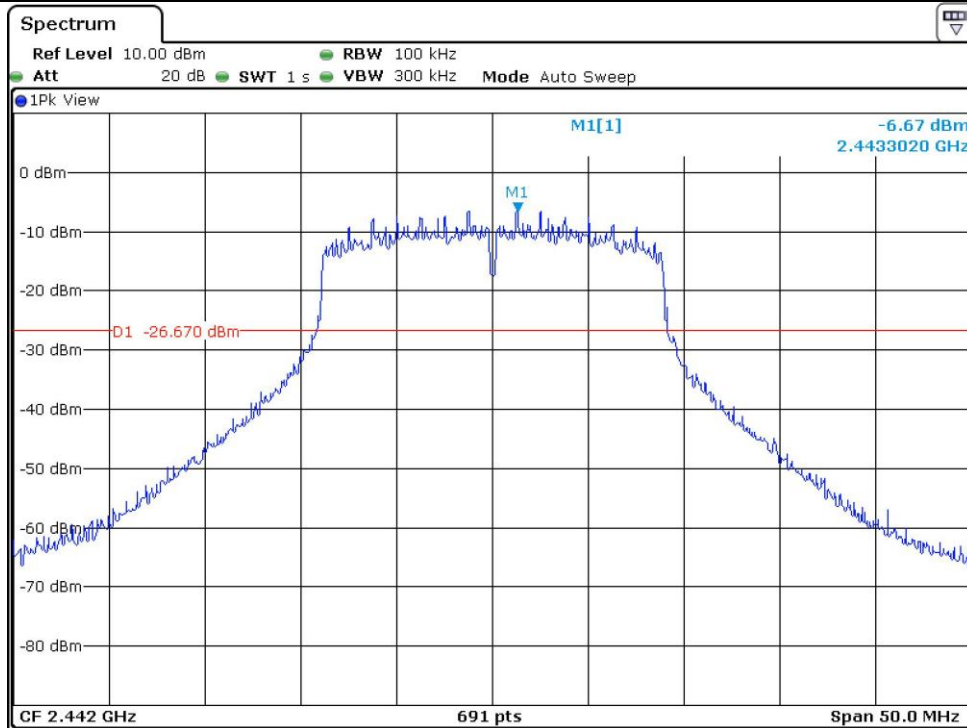

Middle Channel

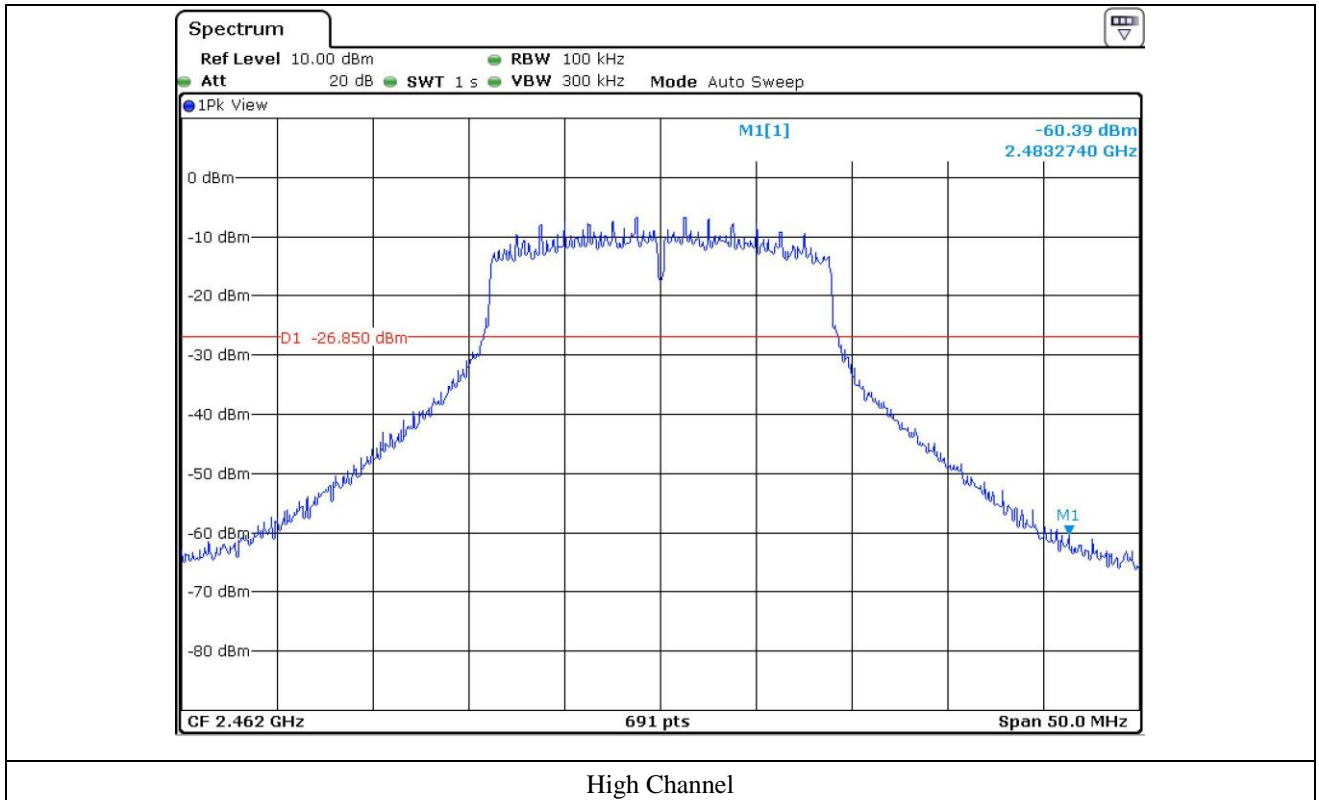

High Channel

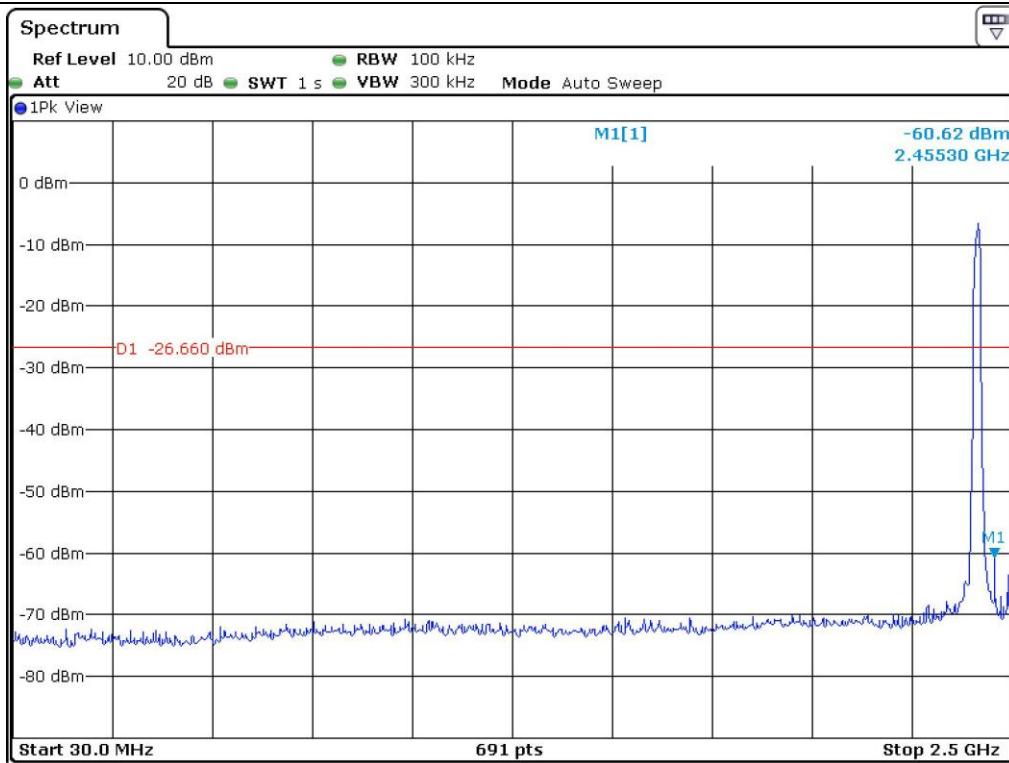

Low Channel

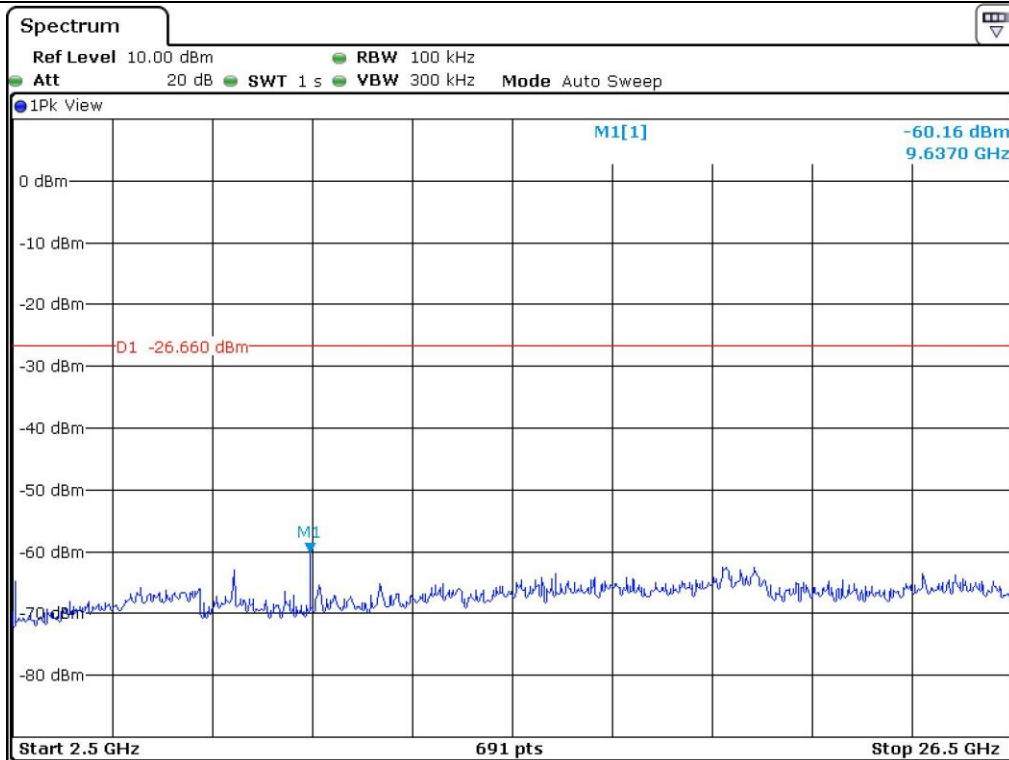

Low Channel

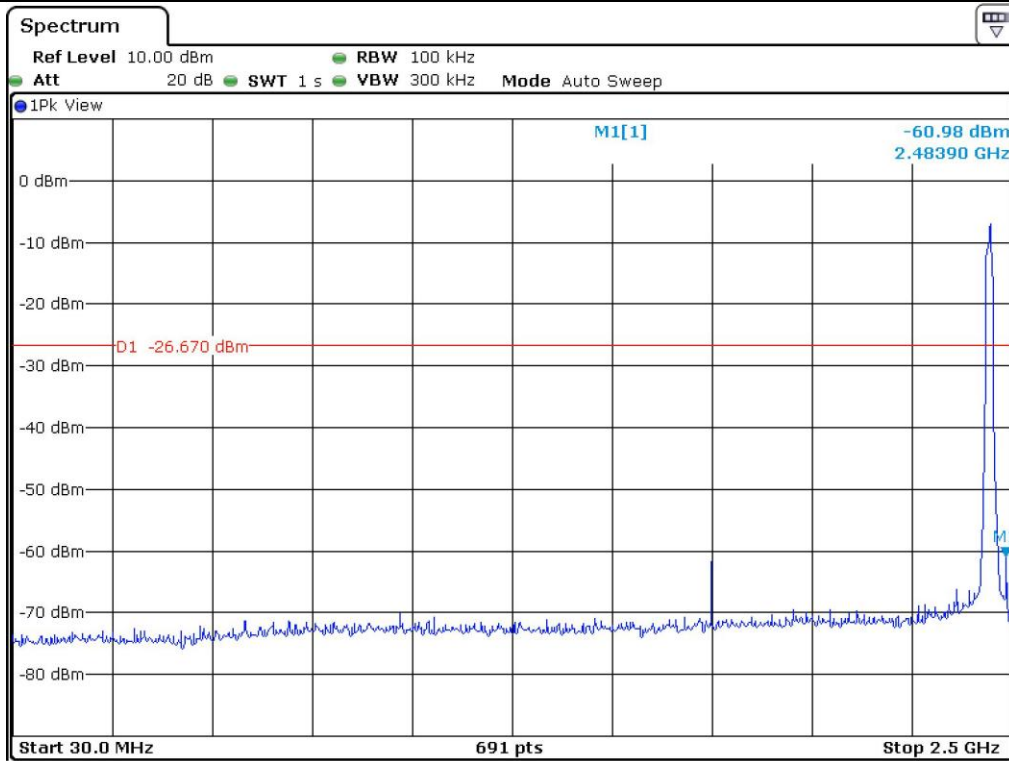

Middle Channel

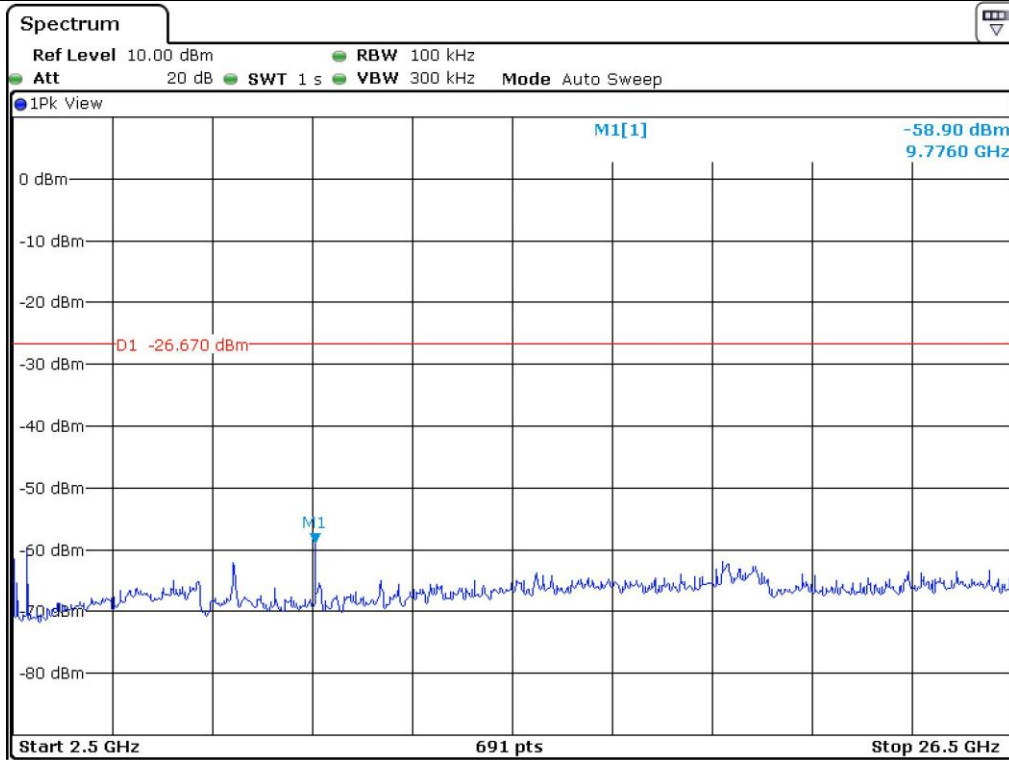

Middle Channel

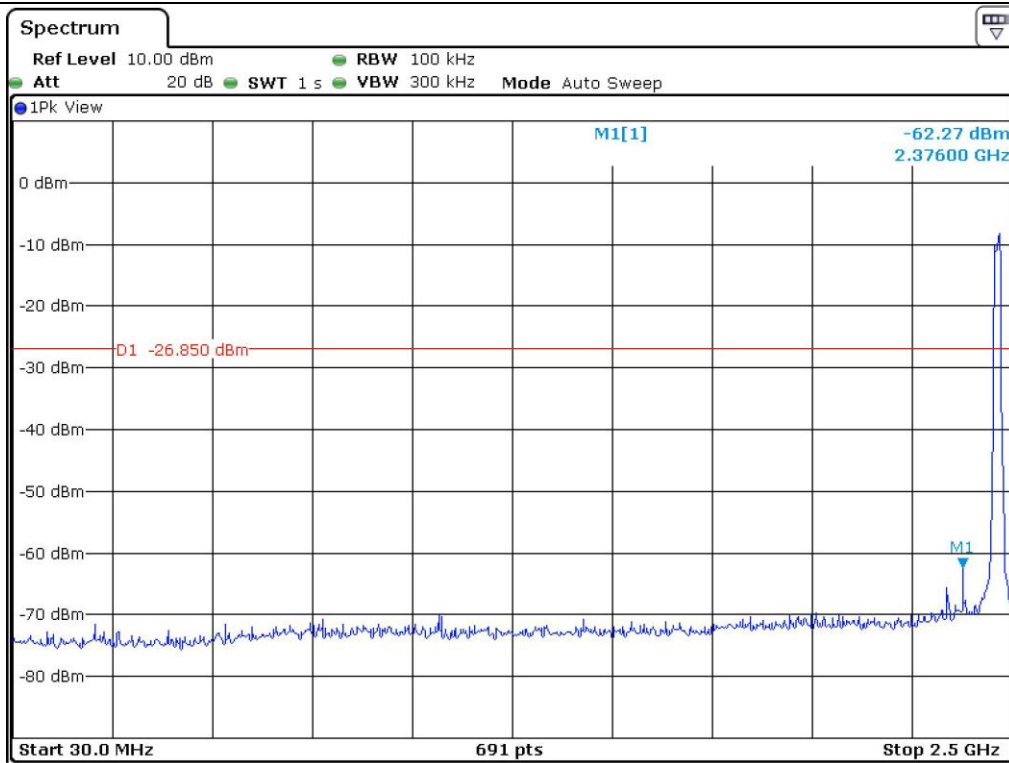

High Channel

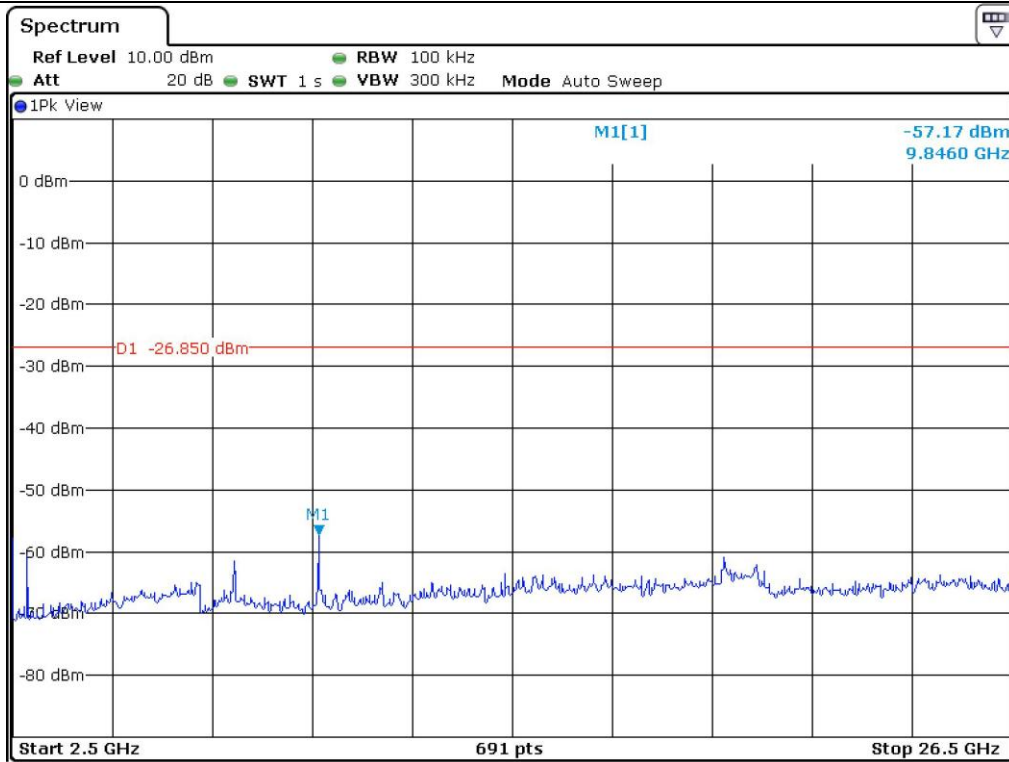

High Channel

9.6 Test data for radiated emission

9.6.1 Radiated Emission which fall in the Restricted Band

9.6.1.1 Test data for 802.11b Mode

- . Test Date : September 23, 2013
- . Resolution bandwidth : 1 MHz for Peak and Average Mode
- . Video bandwidth : 1 MHz for Peak Mode, 10 Hz for Average Mode
- . Frequency range : 30 MHz ~ 26.5 GHz
- . Measurement distance : 3 m
- . Result : PASSED

Frequency (MHz)	Reading (dBμV)	Detector Mode	Ant. Pol. (H/V)	Ant. Factor	Cable Loss	Amp Gain	Total (dBμV/m)	Limits (dBμV/m)	Margin (dB)
Test Data for Low Channel									
2 398.70	49.81	Peak	H	27.20	7.10	43.10	41.01	74.00	32.99
	31.30	Average	H				22.50	54.00	31.50
2 390.00	46.24	Peak	V				37.44	74.00	36.56
	30.15	Average	V				21.35	54.00	32.65
Test Data for High Channel									
2 483.50	46.96	Peak	H	27.40	7.10	43.10	38.36	74.00	35.64
	30.39	Average	H				21.79	54.00	32.21
2 483.53	43.77	Peak	V				35.17	74.00	38.83
	29.97	Average	V				21.37	54.00	32.63

Tabulated test data for Restricted Band

Remark: “H”: Horizontal, “V”: Vertical

$$\text{Margin (dB)} = \text{Limits (dB}\mu\text{V/m)} - \text{Total Level (dB}\mu\text{V/m)}$$

$$\text{Total Level} = \text{Reading} + \text{Antenna Factor} + \text{Cable Loss} - \text{Pre-Amplifier Gain}$$



Tested by: Tae-Ho, Kim / Project Engineer

9.6.1.2 Test data for 802.11g Mode

- . Test Date : September 23, 2013
- . Resolution bandwidth : 1 MHz for Peak and Average Mode
- . Video bandwidth : 1 MHz for Peak Mode, 10 Hz for Average Mode
- . Frequency range : 30 MHz ~ 26.5 GHz
- . Measurement distance : 3 m
- . Result : PASSED

Frequency (MHz)	Reading (dBμV)	Detector Mode	Ant. Pol. (H/V)	Ant. Factor	Cable Loss	Amp Gain	Total (dBμV/m)	Limits (dBμV/m)	Margin (dB)
Test Data for Low Channel									
2 390.00	71.60	Peak	H	27.20	7.10	43.10	62.80	74.00	11.20
	55.12	Average	H				46.32	54.00	7.68
2 390.00	69.43	Peak	V				60.63	74.00	13.37
	53.41	Average	V				44.61	54.00	9.39
Test Data for High Channel									
2 484.02	70.56	Peak	H	27.40	7.10	43.10	61.96	74.00	12.04
	54.21	Average	H				45.61	54.00	8.39
2 483.53	68.39	Peak	V				59.79	74.00	14.21
	52.64	Average	V				44.04	54.00	9.96

Tabulated test data for Restricted Band

Remark: "H": Horizontal, "V": Vertical

$$\text{Margin (dB)} = \text{Limits (dB}\mu\text{V/m)} - \text{Total Level (dB}\mu\text{V/m)}$$

$$\text{Total Level} = \text{Reading} + \text{Antenna Factor} + \text{Cable Loss} - \text{Pre-Amplifier Gain}$$



Tested by: Tae-Ho, Kim / Project Engineer

9.6.1.3 Test data for 802.11n Mode

- . Test Date : September 23, 2013
- . Resolution bandwidth : 1 MHz for Peak and Average Mode
- . Video bandwidth : 1 MHz for Peak Mode, 10 Hz for Average Mode
- . Frequency range : 30 MHz ~ 26.5 GHz
- . Measurement distance : 3 m
- . Result : PASSED

Frequency (MHz)	Reading (dBμV)	Detector Mode	Ant. Pol. (H/V)	Ant. Factor	Cable Loss	Amp Gain	Total (dBμV/m)	Limits (dBμV/m)	Margin (dB)
Test Data for Low Channel									
2 390.00	71.65	Peak	H	27.20	7.10	43.10	62.85	74.00	11.15
	55.34	Average	H				46.54	54.00	7.46
2 390.00	69.09	Peak	V				60.29	74.00	13.71
	53.58	Average	V				44.78	54.00	9.22
Test Data for High Channel									
2 483.63	70.73	Peak	H	27.40	7.10	43.10	62.13	74.00	11.87
	54.65	Average	H				46.05	54.00	7.95
2 483.63	69.24	Peak	V				60.64	74.00	13.36
	52.95	Average	V				44.35	54.00	9.65

Tabulated test data for Restricted Band

Remark: “H”: Horizontal, “V”: Vertical

$$\text{Margin (dB)} = \text{Limits (dB}\mu\text{V/m)} - \text{Total Level (dB}\mu\text{V/m)}$$

$$\text{Total Level} = \text{Reading} + \text{Antenna Factor} + \text{Cable Loss} - \text{Pre-Amplifier Gain}$$



Tested by: Tae-Ho, Kim / Project Engineer

9.6.2 Spurious & Harmonic Radiated Emission

9.6.2.1 Test data for 802.11b Mode

- Test Date : September 23, 2013
- Resolution bandwidth : 1 MHz for Peak and Average Mode for the emissions fall in restricted band,
100 kHz for Peak Mode for the emissions outside restricted band
- Video bandwidth : 1 MHz for Peak Mode, 10 Hz for Average Mode
- Frequency range : 1 GHz ~ 26.5 GHz
- Measurement distance : 3 m
- Result : PASSED

Frequency (GHz)	Reading (dBμV)	Detector Mode	Ant. Pol. (H/V)	Ant. Factor	Cable Loss	Amp Gain	Total (dBμV/m)	Limits (dBμV/m)	Margin (dB)
Test Data for Low Channel									
2 412.00	93.76	Peak	H	27.20	7.10	43.10	84.96	113.98	29.02
	85.54	Average	H				76.74	93.98	17.24
	93.91	Peak	V				85.11	113.98	28.87
	86.60	Average	V				77.80	93.98	16.18
4 824.00	61.98	Peak	H	31.10	9.60	42.40	60.28	73.98	13.70
	45.57	Average	H				43.87	53.98	10.11
	57.82	Peak	V				56.12	73.98	17.86
	44.66	Average	V				42.96	53.98	11.02
Test Data for Middle Channel									
2 442.00	94.24	Peak	H	27.30	7.10	43.10	85.54	113.98	28.44
	85.89	Average	H				77.19	93.98	16.79
	93.65	Peak	V				84.95	113.98	29.03
	84.33	Average	V				75.63	93.98	18.35
4 884.00	62.14	Peak	H	31.30	9.80	42.40	60.84	73.98	13.14
	46.08	Average	H				44.78	53.98	9.20
	59.04	Peak	V				57.74	73.98	16.24
	43.58	Average	V				42.28	53.98	11.70

Test Data for High Channel									
2 462.00	94.22	Peak	H	27.30	7.10	43.10	85.52	113.98	28.46
	85.45	Average	H				76.75	93.98	17.23
	92.47	Peak	V				83.77	113.98	30.21
	83.76	Average	V				75.06	93.98	18.92
4 924.00	62.68	Peak	H	31.30	9.90	42.30	61.58	73.98	12.40
	45.77	Average	H				44.67	53.98	9.31
	58.35	Peak	V				57.25	73.98	16.73
	42.43	Average	V				41.33	53.98	12.65

Tabulated test data for Restricted Band

Remark: "H": Horizontal, "V": Vertical

$$\text{Margin (dB)} = \text{Limits (dB}\mu\text{V/m)} - \text{Total Level (dB}\mu\text{V/m)}$$

$$\text{Total Level} = \text{Reading} + \text{Antenna Factor} + \text{Cable Loss} - \text{Pre-Amplifier Gain}$$



Tested by: Tae-Ho, Kim / Project Engineer

9.6.2.2 Test data for 802.11g Mode

- Test Date : September 23, 2013
- Resolution bandwidth : 1 MHz for Peak and Average Mode for the emissions fall in restricted band,
100 kHz for Peak Mode for the emissions outside restricted band
- Video bandwidth : 1 MHz for Peak Mode, 10 Hz for Average Mode
- Frequency range : 1 GHz ~ 26.5 GHz
- Measurement distance : 3 m
- Result : PASSED

Frequency (GHz)	Reading (dBμV)	Detector Mode	Ant. Pol. (H/V)	Ant. Factor	Cable Loss	Amp Gain	Total (dBμV/m)	Limits (dBμV/m)	Margin (dB)
Test Data for Low Channel									
2 412.00	95.47	Peak	H	27.20	7.10	43.10	86.67	113.98	27.31
	84.87	Average	H				76.07	93.98	17.91
	93.98	Peak	V				85.18	113.98	28.80
	84.16	Average	V				75.36	93.98	18.62
4 824.00	62.41	Peak	H	31.10	9.60	42.40	60.71	73.98	13.27
	44.27	Average	H				42.57	53.98	11.41
	58.31	Peak	V				56.61	73.98	17.37
	42.87	Average	V				41.17	53.98	12.81
Test Data for Middle Channel									
2 442.00	95.66	Peak	H	27.30	7.10	43.10	86.96	113.98	27.02
	85.78	Average	H				77.08	93.98	16.90
	94.26	Peak	V				85.56	113.98	28.42
	84.56	Average	V				75.86	93.98	18.12
4 884.00	61.41	Peak	H	31.30	9.80	42.40	60.11	73.98	13.87
	45.54	Average	H				44.24	53.98	9.74
	58.03	Peak	V				56.73	73.98	17.25
	43.53	Average	V				42.23	53.98	11.75

Test Data for High Channel									
2 462.00	95.35	Peak	H	27.30	7.10	43.10	86.65	113.98	27.33
	86.47	Average	H				77.77	93.98	16.21
	93.38	Peak	V				84.68	113.98	29.30
	84.38	Average	V				75.68	93.98	18.30
4 924.00	63.86	Peak	H	31.30	9.90	42.30	62.76	73.98	11.22
	46.57	Average	H				45.47	53.98	8.51
	59.68	Peak	V				58.58	73.98	15.40
	43.67	Average	V				42.57	53.98	11.41

Tabulated test data for Restricted Band

Remark: “H”: Horizontal, “V”: Vertical

$$\text{Margin (dB)} = \text{Limits (dB}\mu\text{V/m)} - \text{Total Level (dB}\mu\text{V/m)}$$

$$\text{Total Level} = \text{Reading} + \text{Antenna Factor} + \text{Cable Loss} - \text{Pre-Amplifier Gain}$$



Tested by: Tae-Ho, Kim / Project Engineer

9.6.2.3 Test data for 802.11n Mode

- Test Date : September 23, 2013
- Resolution bandwidth : 1 MHz for Peak and Average Mode for the emissions fall in restricted band,
100 kHz for Peak Mode for the emissions outside restricted band
- Video bandwidth : 1 MHz for Peak Mode, 10 Hz for Average Mode
- Frequency range : 1 GHz ~ 26.5 GHz
- Measurement distance : 3 m
- Result : PASSED

Frequency (GHz)	Reading (dBμV)	Detector Mode	Ant. Pol. (H/V)	Ant. Factor	Cable Loss	Amp Gain	Total (dBμV/m)	Limits (dBμV/m)	Margin (dB)
Test Data for Low Channel									
2 412.00	94.76	Peak	H	27.20	7.10	43.10	85.96	113.98	-28.02
	84.23	Average	H				75.43	93.98	-18.55
	95.20	Peak	V				86.40	113.98	-27.58
	84.14	Average	V				75.34	93.98	-18.64
4 824.00	61.53	Peak	H	31.10	9.60	42.40	59.83	73.98	-14.15
	45.99	Average	H				44.29	53.98	-9.69
	58.99	Peak	V				57.29	73.98	-16.69
	43.45	Average	V				41.75	53.98	-12.23
Test Data for Middle Channel									
2 442.00	95.97	Peak	H	27.30	7.10	43.10	87.27	113.98	-26.71
	85.47	Average	H				76.77	93.98	-17.21
	94.48	Peak	V				85.78	113.98	-28.20
	84.32	Average	V				75.62	93.98	-18.36
4 884.00	60.78	Peak	H	31.30	9.80	42.40	59.48	73.98	-14.50
	44.86	Average	H				43.56	53.98	-10.42
	57.63	Peak	V				56.33	73.98	-17.65
	42.88	Average	V				41.58	53.98	-12.40

Test Data for High Channel									
2 462.00	93.69	Peak	H	27.30	7.10	43.10	84.99	113.98	-28.99
	84.87	Average	H				75.17	93.98	-17.81
	92.96	Peak	V				84.26	113.98	-29.72
	83.57	Average	V				74.87	93.98	-19.11
4 924.00	62.49	Peak	H	31.30	9.90	42.30	61.39	73.98	-12.59
	45.72	Average	H				44.62	53.98	-9.36
	59.63	Peak	V				58.53	73.98	-15.45
	42.94	Average	V				41.84	53.98	-12.14

Tabulated test data for Restricted Band

Remark: “H”: Horizontal, “V”: Vertical

$$\text{Margin (dB)} = \text{Limits (dB}\mu\text{V/m)} - \text{Total Level (dB}\mu\text{V/m)}$$

$$\text{Total Level} = \text{Reading} + \text{Antenna Factor} + \text{Cable Loss} - \text{Pre-Amplifier Gain}$$



Tested by: Tae-Ho, Kim / Project Engineer

10 PEAK POWER SPECTRUL DENSITY

10.1 Operating environment

Temperature : 23 °C
Relative humidity : 43 % R.H.

10.2 Test set-up

The antenna output of the EUT was connected to the spectrum analyzer. The resolution bandwidth is set to 100 kHz, the video bandwidth is set to 3 times the resolution bandwidth. The maximum level form the EUT in 100 kHz bandwidth was measured with above condition.



10.3 Test equipment used

Model Number	Manufacturer	Description	Serial Number	Last Cal.
■ - FSV30	R/S	Spectrum Analyzer	101372	May 20, 2013

All test equipment used is calibrated on a regular basis.

10.4 Test data for 802.11b Mode

- Test Date : September 16, 2013
- Test Result : Pass
- Operating Condition : Continuous transmitting mode

CHANNEL	FREQUENCY(MHz)	MEASURED VLAUE (dBm)	LIMIT (dBm)	MARGIN (dB)
Low	2 412	-20.38	8.00	28.38
Middle	2 442	-19.94	8.00	27.94
High	2 462	-20.63	8.00	28.63

Remark. Margin = Limit – Measured value



Tested by: Tae-Ho, Kim / Project Engineer

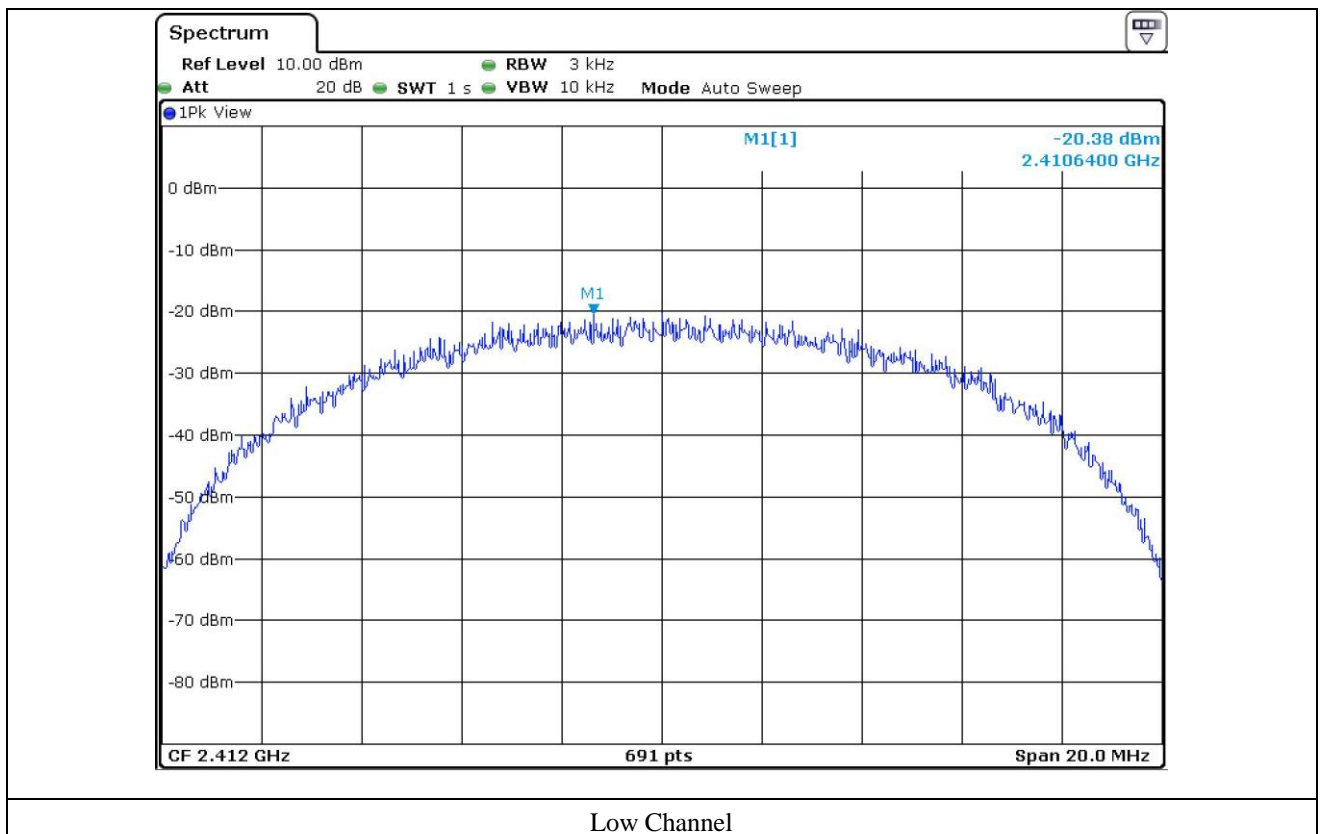

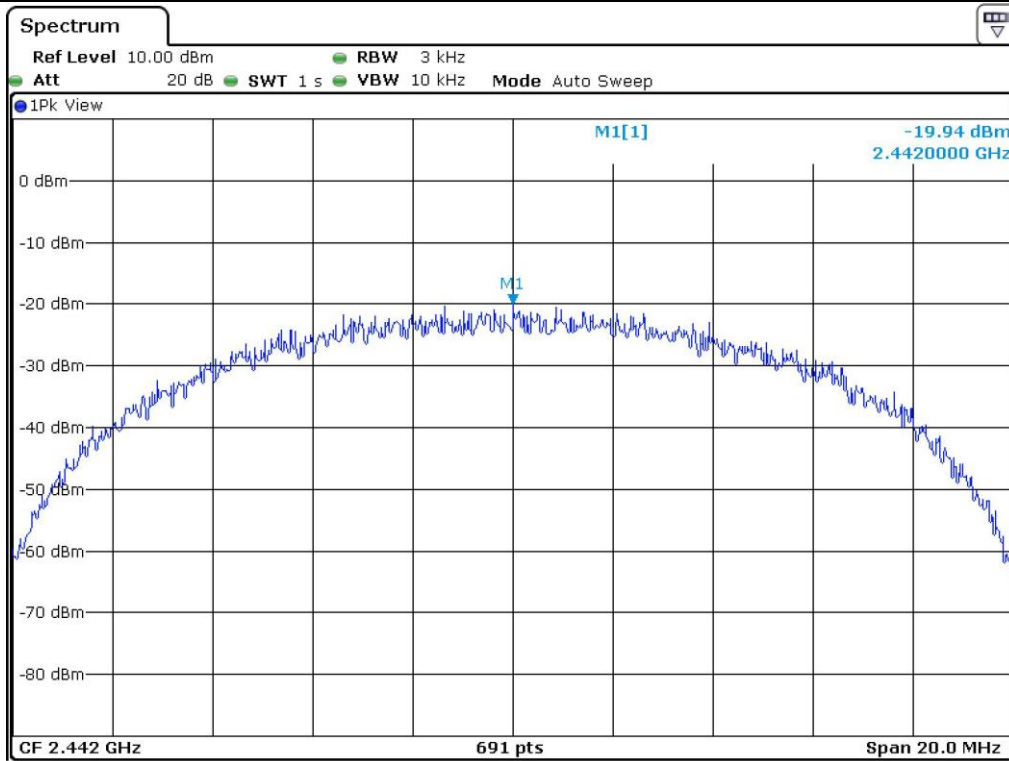

Middle Channel

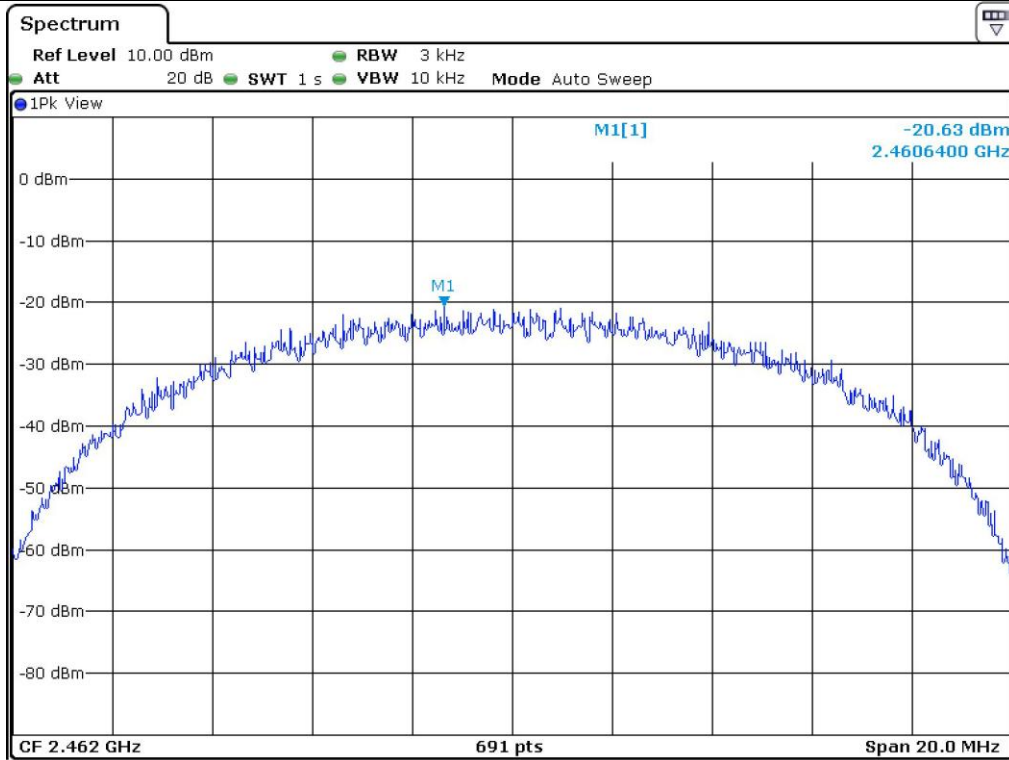

High Channel

10.5 Test data for 802.11g Mode

- Test Date : September 16, 2013
- Test Result : Pass
- Operating Condition : Continuous transmitting mode

CHANNEL	FREQUENCY(MHz)	MEASURED VLAUE (dBm)	LIMIT (dBm)	MARGIN (dB)
Low	2 412	-21.89	8.00	29.89
Middle	2 442	-21.51	8.00	29.51
High	2 462	-22.58	8.00	30.58

Remark. Margin = Limit – Measured value

Tested by: Tae-Ho, Kim / Project Engineer

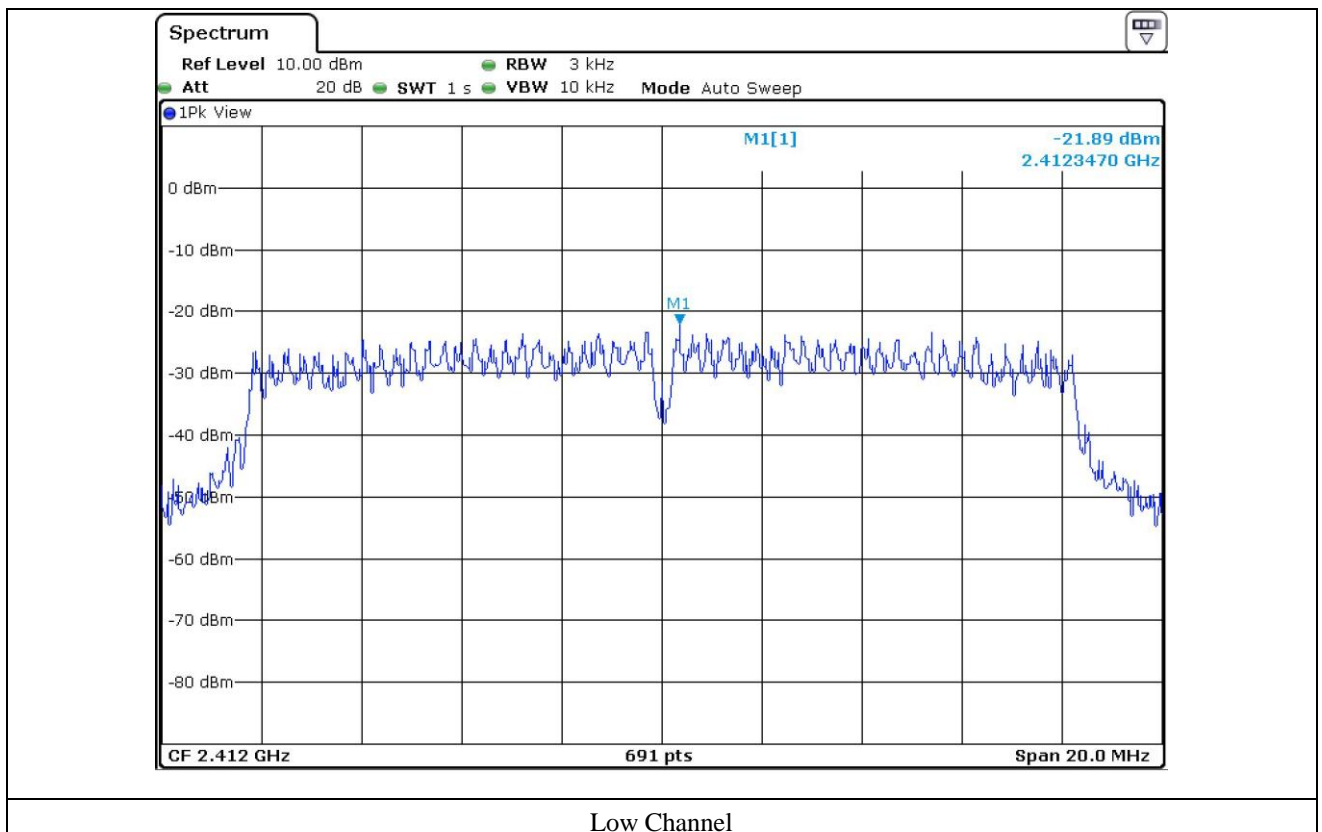

Low Channel

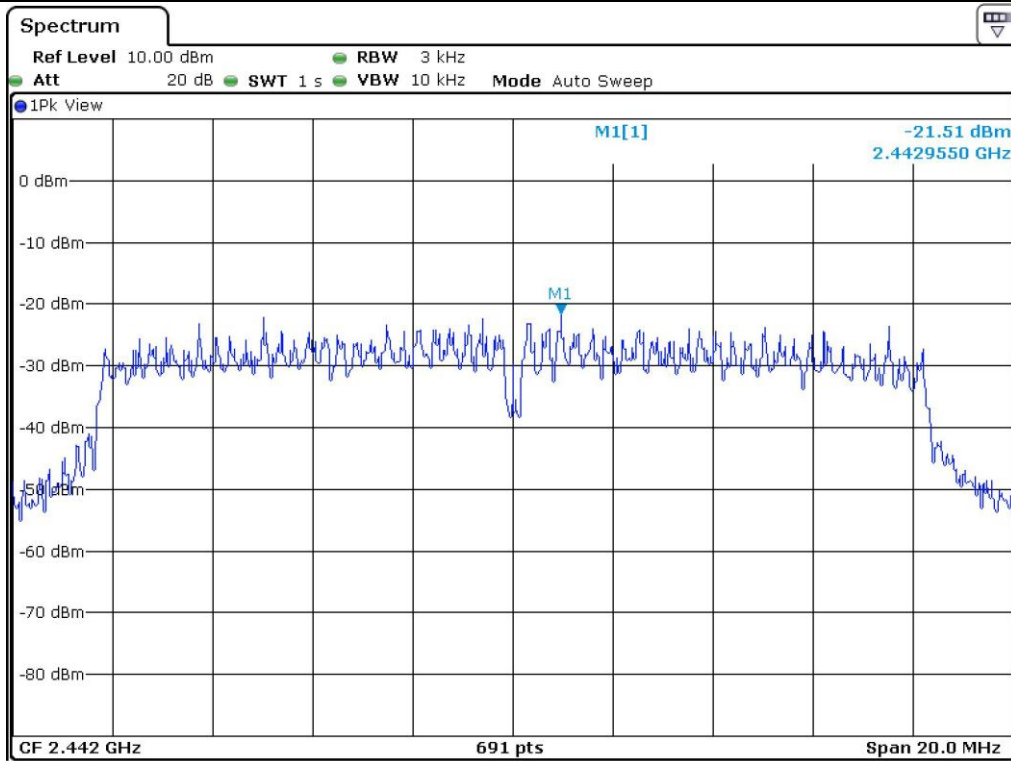

Middle Channel

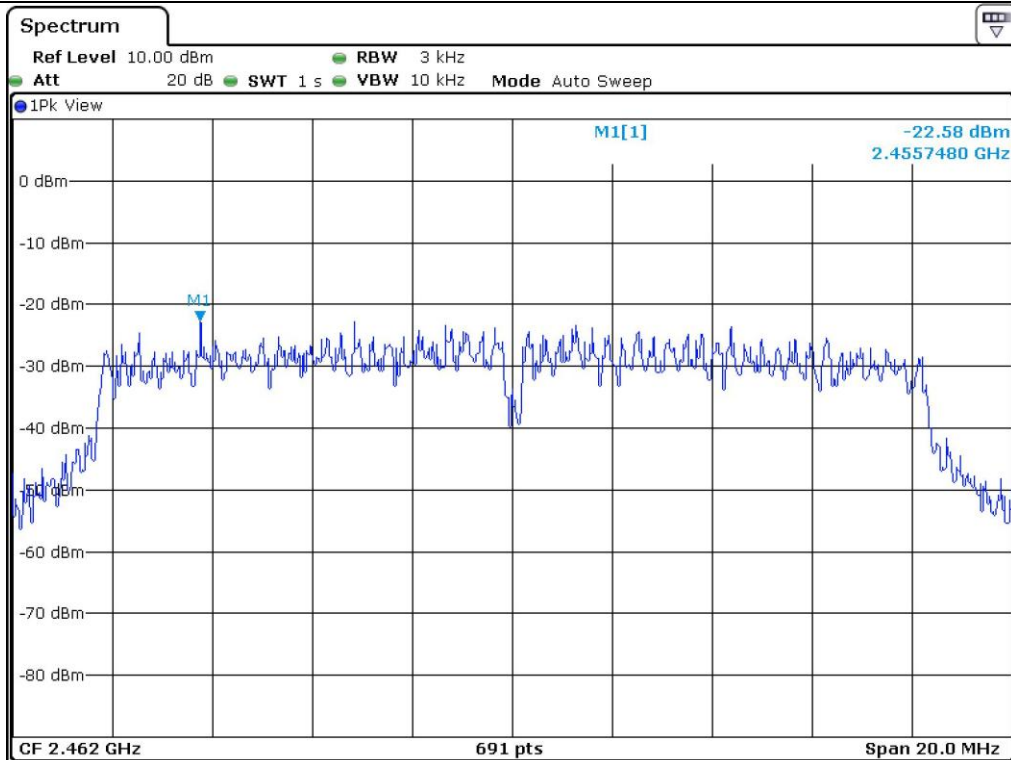

High Channel

10.6 Test data for 802.11n Mode

- Test Date : September 16, 2013
- Test Result : Pass
- Operating Condition : Continuous transmitting mode

CHANNEL	FREQUENCY(MHz)	MEASURED VLAUE (dBm)	LIMIT (dBm)	MARGIN (dB)
Low	2 412	-22.52	8.00	30.52
Middle	2 442	-23.21	8.00	31.21
High	2 462	-21.23	8.00	29.23

Remark. Margin = Limit – Measured value



Tested by: Tae-Ho, Kim / Project Engineer

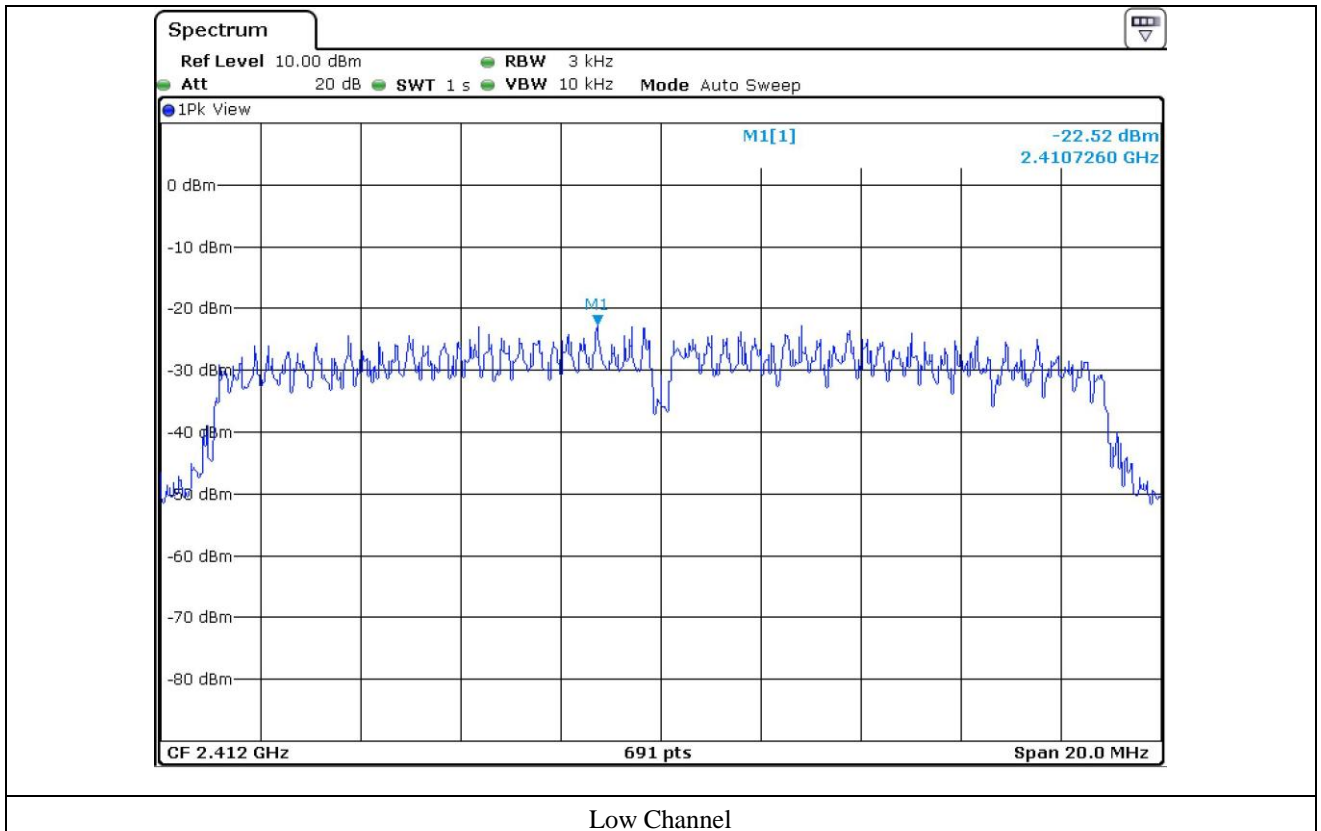

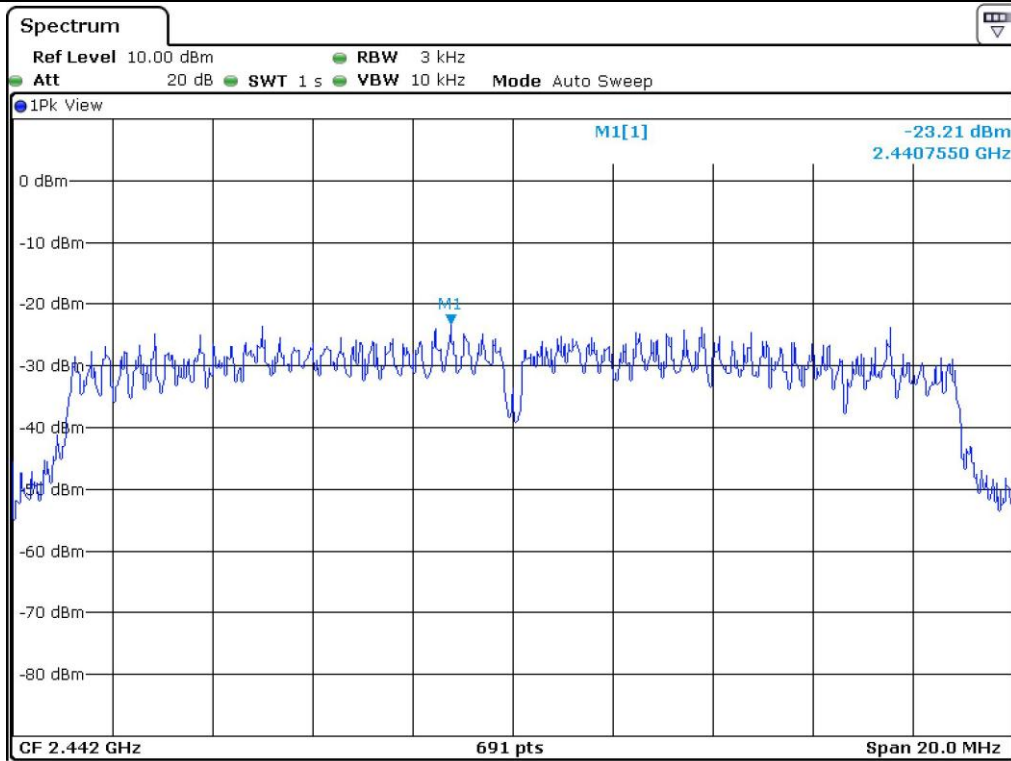

Middle Channel

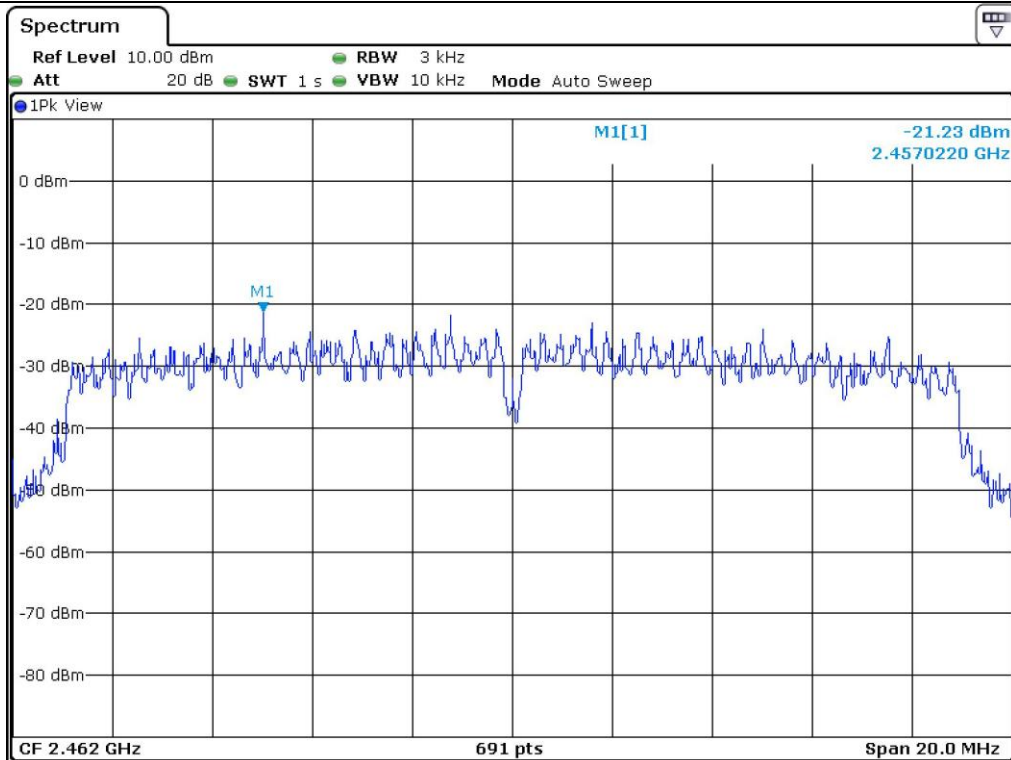

High Channel

11. RADIATED EMISSION TEST

11.1 Operating environment

Temperature : 24 °C
Relative humidity : 46 % R.H.

11.2 Test set-up

The radiated emissions measurements were on the 3 meters, open-field test site. The EUT and other support equipment were placed on a non-conductive turntable above the ground plane. The interconnecting cables from outside test site were inserted into ferrite clamps at the point where the cables reach the turntable.

The frequency spectrum from 9 kHz to 26.5 GHz was scanned and emission levels maximized at each frequency recorded. The system was rotated 360°, and the antenna was varied in height between 1.0 and 4.0 meters in order to determine the maximum emission levels. This procedure was performed for both horizontal and vertical polarization of the receiving antenna.

11.3 Test equipment used

Model Number	Manufacturer	Description	Serial Number	Last Cal. (Interval)
□ - ESCI	Rohde & Schwarz	EMI Test Receiver	101012	Feb. 06, 2013(1Y)
■ - ESU	Rohde & Schwarz	EMI Test Receiver	100261	May 27, 2013(1Y)
□ - 8564E	HP	Spectrum Analyzer	3650A00756	May 03, 2013(1Y)
□ - FSP	Rohde & Schwarz	Spectrum Analyzer	100017	Mar 11, 2013(1Y)
■ - 310N	Sonoma Instrument	AMPLIFIER	312544	May 21, 2013(1Y)
■ - FSV30	Rohde & Schwarz	Signal Analyzer	101372	May 20, 2013(1Y)
■ - SCU-18	Rohde & Schwarz	PRE-AMPLIFIER	10041	Apr. 19, 2013(1Y)
■ - MA240	HD GmbH	Antenna Master	N/A	N/A
■ - HD100	HD GmbH	Position Controller	N/A	N/A
■ - DS420S	HD GmbH	Turn Table	N/A	N/A
■ - HFH2-Z2	Rohde & Schwarz	Loop Antenna	889 285 / 26	Dec. 11, 2012(2Y)
■ - VULB9163	Schwarzbeck	TRILOG Broadband Antenna	VULB9163-255	Apr. 24, 2012(2Y)
■ - BBHA9120D	Schwarzbeck	Horn Antenna	BBHA9120D295	Sep. 05, 2013(2Y)
■ - BBHA9170	Schwarzbeck	Horn Antenna	BBHA9170178	Jun. 17, 2013(2Y)

All test equipment used is calibrated on a regular basis.

11.4 Test data for 802.11b Mode

11.4.1 Test data for 30 MHz ~ 1 000 MHz

- Test Date : September 17, 2013
- Resolution bandwidth : 120 kHz
- Frequency range : 30 MHz ~ 1 000 MHz
- Measurement distance : 3 m
- Operating mode : Transmitting mode
- Channel : Low

Frequency (MHz)	Reading (dB μ V)	Ant. Pol. (H/V)	Ant. Height (m)	Angle (°)	Ant. Factor (dB/m)	Cable Loss	Emission Level(dB μ V/m)	Limits (dB μ V/m)	Margin (dB)
44.55	10.85	H	1.00	360.0	13.08	1.66	25.59	40.00	14.41
98.87	11.85	H	2.00	230.0	11.69	2.28	25.82	43.52	17.70
214.30	11.50	H	1.00	230.0	10.78	3.21	25.49	43.52	18.03
485.90	15.18	H	1.00	90.0	17.14	4.57	36.89	46.02	9.13
485.90	10.52	V	1.00	80.0	17.14	4.57	32.23	46.02	13.79
909.78	10.24	H	3.00	80.0	22.36	7.44	40.04	46.02	5.98

- Channel : Middle

Frequency (MHz)	Reading (dB μ V)	Ant. Pol. (H/V)	Ant. Height (m)	Angle (°)	Ant. Factor (dB/m)	Cable Loss	Emission Level(dB μ V/m)	Limits (dB μ V/m)	Margin (dB)
44.55	10.48	H	1.00	360.0	13.08	1.66	25.22	40.00	14.78
98.87	11.28	H	1.00	230.0	11.69	2.28	25.25	43.52	18.27
214.30	10.98	H	1.00	230.0	10.78	3.21	24.97	43.52	18.55
485.90	14.59	H	1.50	90.0	17.14	4.57	36.30	46.02	9.72
485.90	10.03	V	1.00	80.0	17.14	4.57	31.74	46.02	14.28
909.78	9.85	H	1.00	80.0	22.36	7.44	39.65	46.02	6.37

-. Channel : High

Frequency (MHz)	Reading (dBμV)	Ant. Pol. (H/V)	Ant. Height (m)	Angle (°)	Ant. Factor (dB/m)	Cable Loss	Emission Level(dBμV/m)	Limits (dBμV/m)	Margin (dB)
44.55	10.65	H	1.00	360.0	13.08	1.66	25.39	40.00	14.61
98.87	11.32	H	1.00	230.0	11.69	2.28	25.29	43.52	18.23
214.30	11.26	H	1.00	230.0	10.78	3.21	25.25	43.52	18.27
485.90	14.67	H	1.50	90.0	17.14	4.57	36.38	46.02	9.64
485.90	10.19	V	1.00	80.0	17.14	4.57	31.90	46.02	14.12
909.78	9.92	H	1.00	80.0	22.36	7.44	39.72	46.02	6.30

Tabulated test data for Radiated Electromagnetic Field

Remark: "H": Horizontal, "V": Vertical

$$\text{Margin (dB)} = \text{Limits (dB}\mu\text{V/m)} - \text{Emission Level (dB}\mu\text{V/m)}$$



Tested by: Tae-Ho, Kim / Project Engineer

11.4.2 Test data for Below 30 MHz

- . Test Date : September 17, 2013
- . Resolution bandwidth : 200 Hz (from 9 kHz to 0.15 MHz), 9 kHz (from 0.15 MHz to 30 MHz)
- . Frequency range : 9 kHz ~ 30 MHz
- . Measurement distance : 3 m
- . Operating mode : Transmitting mode

Frequency (MHz)	Reading (dBμV)	Ant. Pol. (H/V)	Ant. Height (m)	Angle (°)	Ant. Factor (dB/m)	Cable Loss	Emission Level(dBμV/m)	Limits (dBμV/m)	Margin (dB)
It was not observed any emissions from the EUT.									

11.4.3 Test data for above 1 GHz

- . Test Date : September 17, 2013
- . Resolution bandwidth : 1 MHz for Peak and Average Mode
- . Video bandwidth : 1 MHz for Peak Mode, 10 Hz for Average Mode
- . Frequency range : 1 GHz ~ 26.5 GHz
- . Measurement distance : 3 m
- . Operating mode : Transmitting mode

Frequency (MHz)	Reading (dBμV)	Ant. Pol. (H/V)	Ant. Height (m)	Angle (°)	Ant. Factor (dB/m)	Cable Loss	Emission Level(dBμV/m)	Limits (dBμV/m)	Margin (dB)
It was not observed any emissions from the EUT.									



Tested by: Tae-Ho, Kim / Project Engineer

11.5 Test data for 802.11g Mode

11.5.1 Test data for 30 MHz ~ 1 000 MHz

- Test Date : September 17, 2013
- Resolution bandwidth : 120 kHz
- Frequency range : 30 MHz ~ 1 000 MHz
- Measurement distance : 3 m
- Operating mode : Transmitting mode
- Channel : Low

Frequency (MHz)	Reading (dBμV)	Ant. Pol. (H/V)	Ant. Height (m)	Angle (°)	Ant. Factor (dB/m)	Cable Loss	Emission Level(dBμV/m)	Limits (dBμV/m)	Margin (dB)
39.70	10.67	V	1.00	360.0	12.50	1.29	24.46	40.00	15.54
101.78	11.69	H	2.00	230.0	11.63	2.32	25.64	43.52	17.88
214.30	11.20	H	1.00	230.0	10.78	3.21	25.19	43.52	18.33
497.54	15.42	H	1.00	90.0	17.33	4.60	37.35	46.02	8.67
497.54	9.55	V	1.00	80.0	17.33	4.60	31.48	46.02	14.54
909.78	11.26	H	3.00	80.0	22.36	7.44	41.06	46.02	4.96

- Channel : Middle

Frequency (MHz)	Reading (dBμV)	Ant. Pol. (H/V)	Ant. Height (m)	Angle (°)	Ant. Factor (dB/m)	Cable Loss	Emission Level(dBμV/m)	Limits (dBμV/m)	Margin (dB)
39.70	10.25	V	1.00	360.0	12.50	1.29	24.04	40.00	15.96
101.78	11.35	H	1.00	230.0	11.63	2.32	25.30	43.52	18.22
214.30	10.83	H	1.00	230.0	10.78	3.21	24.82	43.52	18.70
497.54	14.96	H	1.50	90.0	17.33	4.60	36.89	46.02	9.13
497.54	9.21	V	1.00	80.0	17.33	4.60	31.14	46.02	14.88
909.78	10.97	H	1.00	80.0	22.36	7.44	40.77	46.02	5.25

-. Channel : High

Frequency (MHz)	Reading (dBμV)	Ant. Pol. (H/V)	Ant. Height (m)	Angle (°)	Ant. Factor (dB/m)	Cable Loss	Emission Level(dBμV/m)	Limits (dBμV/m)	Margin (dB)
39.70	10.28	V	1.00	360.0	12.50	1.29	24.07	40.00	15.93
101.78	11.83	H	1.00	230.0	11.63	2.32	25.78	43.52	17.74
214.30	10.75	H	1.00	230.0	10.78	3.21	24.74	43.52	18.78
497.54	15.31	H	1.50	90.0	17.33	4.60	37.24	46.02	8.78
497.54	9.61	V	1.00	80.0	17.33	4.60	31.54	46.02	14.48
909.78	10.65	H	1.00	80.0	22.36	7.44	40.45	46.02	5.57

Tabulated test data for Radiated Electromagnetic Field

Remark: “H”: Horizontal, “V”: Vertical

$$\text{Margin (dB)} = \text{Limits (dB}\mu\text{V/m)} - \text{Emission Level (dB}\mu\text{V/m)}$$



Tested by: Tae-Ho, Kim / Project Engineer

11.5.2 Test data for Below 30 MHz

- . Test Date : September 17, 2013
- . Resolution bandwidth : 200 Hz (from 9 kHz to 0.15 MHz), 9 kHz (from 0.15 MHz to 30 MHz)
- . Frequency range : 9 kHz ~ 30 MHz
- . Measurement distance : 3 m
- . Operating mode : Transmitting mode

Frequency (MHz)	Reading (dBµV)	Ant. Pol. (H/V)	Ant. Height (m)	Angle (°)	Ant. Factor (dB/m)	Cable Loss	Emission Level(dBµV/m)	Limits (dBµV/m)	Margin (dB)
It was not observed any emissions from the EUT.									

11.5.3 Test data for above 1 GHz

- . Test Date : September 17, 2013
- . Resolution bandwidth : 1 MHz for Peak and Average Mode
- . Video bandwidth : 1 MHz for Peak Mode, 10 Hz for Average Mode
- . Frequency range : 1 GHz ~ 26.5 GHz
- . Measurement distance : 3 m
- . Operating mode : Transmitting mode

Frequency (MHz)	Reading (dBµV)	Ant. Pol. (H/V)	Ant. Height (m)	Angle (°)	Ant. Factor (dB/m)	Cable Loss	Emission Level(dBµV/m)	Limits (dBµV/m)	Margin (dB)
It was not observed any emissions from the EUT.									



Tested by: Tae-Ho, Kim / Project Engineer

11.6 Test data for 802.11n Mode

11.6.1 Test data for 30 MHz ~ 1 000 MHz

- Test Date : September 17, 2013
- Resolution bandwidth : 120 kHz
- Frequency range : 30 MHz ~ 1 000 MHz
- Measurement distance : 3 m
- Operating mode : Transmitting mode
- Channel : Low

Frequency (MHz)	Reading (dBμV)	Ant. Pol. (H/V)	Ant. Height (m)	Angle (°)	Ant. Factor (dB/m)	Cable Loss	Emission Level(dBμV/m)	Limits (dBμV/m)	Margin (dB)
48.43	11.27	V	1.00	360.0	13.03	1.70	26.00	40.00	14.00
101.78	12.38	H	2.00	230.0	11.63	2.32	26.33	43.52	17.19
214.30	10.85	H	1.00	230.0	10.78	3.21	24.84	43.52	18.68
482.99	14.42	H	1.00	90.0	17.09	4.57	36.08	46.02	9.94
482.99	11.20	V	1.00	80.0	17.09	4.57	32.86	46.02	13.16
910.75	12.33	H	3.00	80.0	22.37	7.44	42.14	46.02	3.88

- Channel : Middle

Frequency (MHz)	Reading (dBμV)	Ant. Pol. (H/V)	Ant. Height (m)	Angle (°)	Ant. Factor (dB/m)	Cable Loss	Emission Level(dBμV/m)	Limits (dBμV/m)	Margin (dB)
48.43	11.04	V	1.00	360.0	13.03	1.70	25.77	40.00	14.23
101.78	12.08	H	1.00	230.0	11.63	2.32	26.03	43.52	17.49
214.30	10.59	H	1.00	230.0	10.78	3.21	24.58	43.52	18.94
482.99	14.21	H	1.50	90.0	17.09	4.57	35.87	46.02	10.15
482.99	10.89	V	1.00	80.0	17.09	4.57	32.55	46.02	13.47
910.75	12.03	H	1.00	80.0	22.37	7.44	41.84	46.02	4.18

-. Channel : High

Frequency (MHz)	Reading (dBμV)	Ant. Pol. (H/V)	Ant. Height (m)	Angle (°)	Ant. Factor (dB/m)	Cable Loss	Emission Level(dBμV/m)	Limits (dBμV/m)	Margin (dB)
48.43	11.18	V	1.00	360.0	13.03	1.70	25.91	40.00	14.09
101.78	12.51	H	1.00	230.0	11.63	2.32	26.46	43.52	17.06
214.30	10.75	H	1.00	230.0	10.78	3.21	24.74	43.52	18.78
482.99	14.79	H	1.50	90.0	17.09	4.57	36.45	46.02	9.57
482.99	11.41	V	1.00	80.0	17.09	4.57	33.07	46.02	12.95
910.75	12.40	H	1.00	80.0	22.37	7.44	42.21	46.02	3.81

Tabulated test data for Radiated Electromagnetic Field

Remark: “H”: Horizontal, “V”: Vertical

$$\text{Margin (dB)} = \text{Limits (dB}\mu\text{V/m)} - \text{Emission Level (dB}\mu\text{V/m)}$$



Tested by: Tae-Ho, Kim / Project Engineer

11.6.2 Test data for Below 30 MHz

- . Test Date : September 17, 2013
- . Resolution bandwidth : 200 Hz (from 9 kHz to 0.15 MHz), 9 kHz (from 0.15 MHz to 30 MHz)
- . Frequency range : 9 kHz ~ 30 MHz
- . Measurement distance : 3 m
- . Operating mode : Transmitting mode

Frequency (MHz)	Reading (dBμV)	Ant. Pol. (H/V)	Ant. Height (m)	Angle (°)	Ant. Factor (dB/m)	Cable Loss	Emission Level(dBμV/m)	Limits (dBμV/m)	Margin (dB)
It was not observed any emissions from the EUT.									

11.6.3 Test data for above 1 GHz

- . Test Date : September 17, 2013
- . Resolution bandwidth : 1 MHz for Peak and Average Mode
- . Video bandwidth : 1 MHz for Peak Mode, 10 Hz for Average Mode
- . Frequency range : 1 GHz ~ 26.5 GHz
- . Measurement distance : 3 m
- . Operating mode : Transmitting mode

Frequency (MHz)	Reading (dBμV)	Ant. Pol. (H/V)	Ant. Height (m)	Angle (°)	Ant. Factor (dB/m)	Cable Loss	Emission Level(dBμV/m)	Limits (dBμV/m)	Margin (dB)
It was not observed any emissions from the EUT.									



Tested by: Tae-Ho, Kim / Project Engineer

12. RADIO FREQUENCY EXPOSURE

12.1 RF Exposure Limit

According to the FCC rule §1.1310, the limit for General Population/Uncontrolled exposure is 1 mW/cm² for the device operating 1 500 ~ 100 000 MHz.

12.2 EUT Description

Kind of EUT	Remote Control
Operating Frequency Band	<input type="checkbox"/> Wireless Microphone: 494.000 MHz ~ 501.000 MHz and 498.200 MHz ~ 505.200 MHz <input checked="" type="checkbox"/> WLAN: 2 412 MHz ~ 2 462 MHz <input type="checkbox"/> WLAN: 5 180 MHz ~ 5 320 MHz / 5 500 MHz ~ 5 700 MHz <input type="checkbox"/> WLAN: 5 745 MHz ~ 5 825 MHz <input type="checkbox"/> Bluetooth: 2 402 MHz ~ 2 480 MHz
Device Category	<input type="checkbox"/> Portable (< 20 cm separation) <input type="checkbox"/> Mobile (> 20 cm separation) <input checked="" type="checkbox"/> Others
Max. Output Power	802.11b: 3.56 dBm 802.11g: 2.87 dBm 802.11n(HT20): 2.88 dBm
Used Antenna	Dielectric Chip Antenna
Used Antenna Gain	3.40 dBi
Exposure Evaluation Applied	<input checked="" type="checkbox"/> MPE <input type="checkbox"/> SAR <input type="checkbox"/> N/A

12.3 Test Result

According to the procedure, KDB 447498 D01, the standalone SAR test exclusion threshold is

$$[(\text{Max. Power of channel, including tune-up tolerance, mW})/(\text{Mim. test separation distance, mm})] \times [\sqrt{f(\text{GHz})}] < 3$$

$$= [2.27/5] \times \sqrt{2.442} = 0.71$$

Conclusion: The SAR test exclusion threshold is less than 3, so the device meets the RF Exposure Requirement and excluded SAR Test.