



A D T

FCC TEST REPORT

REPORT NO.: RF971117H03A

MODEL NO.: RTU7305 BG1/3 HMC V2C

RECEIVED: Apr. 09, 2009

TESTED: Apr. 14 ~ Apr. 23, 2009

ISSUED: May 07, 2009

APPLICANT: Realtek Semiconductor Corp.

ADDRESS: No. 2, Innovation Road II, Hsinchu Science Park, Hsinchu 300, Taiwan

ISSUED BY: Bureau Veritas Consumer Products Services (H.K.) Ltd., Taoyuan Branch

LAB ADDRESS: No. 47, 14th Ling, Chia Pau Tsuen, Lin Kou Hsiang, Taipei Hsien 244, Taiwan, R.O.C.

TEST LOCATION: No. 19, Hwa Ya 2nd Rd, Wen Hwa Tsuen, Kwei Shan Hsiang, Taoyuan Hsien 333, Taiwan, R.O.C.

This test report consists of 115 pages in total. It may be duplicated completely for legal use with the approval of the applicant. It should not be reproduced except in full, without the written approval of our laboratory. The client should not use it to claim product endorsement by TAF or any government agencies. The test results in the report only apply to the tested sample.





Table of Contents

1.	CERTIFICATION	4
2.	SUMMARY OF TEST RESULTS	5
2.1	MEASUREMENT UNCERTAINTY	5
3.	GENERAL INFORMATION.....	6
3.1	GENERAL DESCRIPTION OF EUT.....	6
3.1.1.	TEST MODE APPLICABILITY AND TESTED CHANNEL DETAIL.....	7
3.2	GENERAL DESCRIPTION OF APPLIED STANDARDS	9
3.3	DESCRIPTION OF SUPPORT UNITS	10
3.4	OPERATIONAL LIMITATIONS	11
4.	TEST TYPES AND RESULTS	12
4.1	CONDUCTED EMISSION MEASUREMENT	12
4.1.1.	LIMITS OF CONDUCTED EMISSION MEASUREMENT	12
4.1.2.	TEST INSTRUMENTS	12
4.1.3.	TEST PROCEDURES	13
4.1.4.	DEVIATION FROM TEST STANDARD	13
4.1.5.	TEST SETUP	14
4.1.6.	EUT OPERATING CONDITIONS	14
4.1.7.	TEST RESULTS	15
4.2	RADIATED EMISSION MEASUREMENT (FOR 15.519 (c)).....	31
4.2.1	LIMITS OF RADIATED EMISSION MEASUREMENT	31
4.2.2	INSTRUMENT SETUP VALUE AND MEASUREMENT DISTANCE	32
4.2.3	TEST INSTRUMENTS	33
4.2.4	TEST PROCEDURES	34
4.2.5	DEVIATION FROM TEST STANDARD	34
4.2.6	TEST SETUP	35
4.2.7	EUT OPERATING CONDITIONS	35
4.2.8	TEST RESULTS	36
4.3	RADIATED EMISSION MEASUREMENT (FOR 15.519 (d)).....	64
4.3.1	LIMITS OF RADIATED EMISSION MEASUREMENT	64
4.3.2	INSTRUMENT SETUP VALUE AND MEASUREMENT DISTANCE	65
4.3.3	TEST INSTRUMENTS	65
4.3.4	TEST PROCEDURES	66
4.3.5	DEVIATION FROM TEST STANDARD	66
4.3.6	TEST SETUP	67
4.3.7	EUT OPERATING CONDITIONS	67
4.3.8	TEST RESULTS	68
4.4	UWB BANDWIDTH MEASUREMENT	96
4.4.1	LIMITS OF UWB BANDWIDTH MEASUREMENT	96
4.4.2	INSTRUMENT SETUP VALUE AND MEASUREMENT DISTANCE	96
4.4.3	TEST INSTRUMENT	96
4.4.4	TEST PROCEDURE	96
4.4.5	DEVIATION FROM TEST STANDARD	97



4.4.6	TEST SETUP	97
4.4.7	EUT OPERATING CONDITIONS	97
4.4.8	TEST RESULTS	98
4.5	PEAK EMISSION WITHIN A 50MHz BANDWIDTH	106
4.5.1	LIMITS OF PEAK EMISSION	106
4.5.2	INSTRUMENT SETUP VALUE AND MEASUREMENT DISTANCE	106
4.5.3	TEST INSTRUMENTS	107
4.5.4	TEST PROCEDURE	107
4.5.5	DEVIATION FROM TEST STANDARD	107
4.5.6	TEST SETUP	107
4.5.7	EUT OPERATING CONDITIONS	107
4.5.8	TEST RESULTS	108
4.6	ANTENNA REQUIREMENT	112
4.6.1	STANDARD APPLICABLE	112
4.6.2	ANTENNA CONNECTED CONSTRUCTION	112
5.	PHOTOGRAPHS OF THE TEST CONFIGURATION.....	113
6.	INFORMATION ON THE TESTING LABORATORIES	114
7.	APPENDIX A - MODIFICATIONS RECORDERS FOR ENGINEERING CHANGES TO THE EUT BY THE LAB.....	115



A D T

1. CERTIFICATION

PRODUCT: UWB BG13 HMC
MODEL: RTU7305 BG1/3 HMC V2C
BRAND: Realtek
APPLICANT: Realtek Semiconductor Corp.
TESTED: Apr. 14 ~ Apr. 23, 2009
TEST SAMPLE: ENGINEERING SAMPLE
STANDARDS: **FCC Part 15, Subpart F (Section 15.519)**
ANSI C63.4-2003

The above equipment (model: RTU7305 BG1/3 HMC V2C) have been tested by **Bureau Veritas Consumer Products Services (H.K.) Ltd., Taoyuan Branch**, and found compliance with the requirement of the above standards. The test record, data evaluation & Equipment Under Test (EUT) configurations represented herein are true and accurate accounts of the measurements of the sample's EMC characteristics under the conditions specified in this report.

PREPARED BY : Rennie Wang , **DATE:** May 07, 2009
Rennie Wang / Supervisor

TECHNICAL ACCEPTANCE : Long Chen , **DATE:** May 07, 2009
Responsible for RF Long Chen / Senior Engineer

APPROVED BY : Gary Chang , **DATE:** May 07, 2009
Gary Chang / Assistant Manager



2. SUMMARY OF TEST RESULTS

The EUT has been tested according to the following specifications:

APPLIED STANDARD: FCC PART 15, SUBPART F			
STANDARD SECTION	TEST TYPE AND LIMIT	RESULT	REMARK
15.207	AC Power Conducted Emission	PASS	Meet the requirement of limit. Minimum passing margin is -12.36dB at 0.199MHz.
15.519(b)	UWB Bandwidth	PASS	Meet the requirement of limit.
15.209 15.519(c)	Radiated Emissions	PASS	Meet the requirement of limit. Minimum passing margin is -1.08dB at 3308.00MHz & 3392.00MHz.
15.209 15.519(d)	Radiated Emissions in GPS Band	PASS	Meet the requirement of limit. Minimum passing margin is -18.63dB at 1212.50MHz.
15.519(e)	Peak Emissions within a 50MHz Bandwidth	PASS	Meet the requirement of limit. Minimum passing margin is -4.75dB at 3240.00MHz.

2.1 MEASUREMENT UNCERTAINTY

Where relevant, the following measurement uncertainty levels have been estimated for tests performed on the EUT as specified in CISPR 16-4-2:

MEASUREMENT	FREQUENCY	UNCERTAINTY
Conducted emissions	150kHz~30MHz	2.44 dB
Radiated emissions	30MHz ~ 200MHz	3.34 dB
	200MHz ~1000MHz	3.35 dB
	1GHz ~ 18GHz	2.26 dB
	18GHz ~ 40GHz	1.94 dB

This uncertainty represents an expanded uncertainty expressed at approximately the 95% confidence level using a coverage factor of k=2.



3. GENERAL INFORMATION

3.1 GENERAL DESCRIPTION OF EUT

PRODUCT	UWB BG13 HMC
MODEL NO.	RTU7305 BG1/3 HMC V2C
FCC ID	TX2RTU7305BG13HMC
POWER SUPPLY	3.3Vdc from host equipment
MODULATION TECHNOLOGY	Multi-band OFDM
FREQUENCY RANGE	3.1 to 4.8GHz, 6.3 to 8.0GHz (Supporting up to 3 MBOA sub-bands, 528MHz each)
MAXIMUM OUTPUT POWER	-19.27dBm (75.93dBuV/m) for Band Group 1 -20.74dBm (74.46dBuV/m) for Band Group 3
ANTENNA TYPE	Refer to NOTE 2
I/O PORTS	PCIe
DATA CABLE	NA
ACCESSORY DEVICES	NA

NOTE:

1. This report is prepared for FCC class II permissive change. Differences compared with the original report are listed as below, therefore all test items had been re-tested.

ITEM	CLASS II CHANGE DESCRIPTION
1	Modify RF architecture that includes receiver components value and RF components location in layout to have better receive blocking performance.
2	Modify power plan that use single regulator to save PCB space in layout.
3	Add one Monopole antenna.
4	Two designs of EUT. With or without metal shielding case on rear side.

2. The following antennas are used in this EUT. (New antenna was marked in boldface.)

NO.	BRAND	MODEL	TYPE	GAIN (dBi)	CONNECTOR
1	Fujitsu	CP313580-01	Inverted F	3.44	50 ohm Coaxial Length : 500mm Diameter : 1.13mm Connector : U.FL
2	ASUS	APP6M-100000	Monopole	1.45	Connector Type : MCX

3. The above EUT information was declared by manufacturer and for more detailed features description, please refer to the manufacturer's specifications or User's Manual.

3.1.1. TEST MODE APPLICABILITY AND TESTED CHANNEL DETAIL

Four transmission modes of each band group are provided to this EUT.

BAND GROUP	MODE	SUB-BAND	FREQUENCY (MHz)
1	1	1	3432
	2	2	3960
	3	3	4488
	4	1 + 2 + 3	3432, 3960, 4488
3	5	1	6600
	6	2	7128
	7	3	7656
	8	1 + 2 + 3	6600, 7128, 7656

NOTE: After pre-testing each mode, the mode 4 & 8 (TCF3, 53.3Mbps) was the worst situation and only the data was presented in the following sections.

EUT configure mode	Applicable to					Description	
	PLC	RE<1G	RE≥1G	UB	PE		
A	√	√	√	√	√	Fujitsu antenna, BG1	without metal shielding case on rear side
B	√	√	√	√	√	Fujitsu antenna, BG3	
C	√	√	√	√	√	ASUS antenna, BG1	
D	√	√	√	√	√	ASUS antenna, BG3	
E	√	√	√	√	√	Fujitsu antenna, BG1	with metal shielding case on rear side
F	√	√	√	√	√	Fujitsu antenna, BG3	
G	√	√	√	√	√	ASUS antenna, BG1	
H	√	√	√	√	√	ASUS antenna, BG3	

Where **PLC:** Power Line Conducted Emission
RE≥1G: Radiated Emission above 1GHz
PE: Peak Emission

RE<1G: Radiated Emission below 1GHz
UB:UBW Bandwidth

**POWER LINE CONDUCTED EMISSION TEST:**

- Pre-Scan has been conducted to determine the worst-case mode from all possible combinations between available modulations and antenna ports (if EUT with antenna diversity architecture).
- Following channel(s) was (were) selected for the final test as listed below.

EUT CONFIGURE MODE	TESTED SUB-BAND	MODULATION TECHNOLOGY
A ~ H	1 + 2 + 3	MOFDM

RADIATED EMISSION TEST (BELOW 960 MHz):

- Pre-Scan has been conducted to determine the worst-case mode from all possible combinations between available modulations, XYZ axis and antenna ports (if EUT with antenna diversity architecture).
- Following channel(s) was (were) selected for the final test as listed below.

EUT CONFIGURE MODE	TESTED SUB-BAND	MODULATION TECHNOLOGY	AXIS
A ~ H	1 + 2 + 3	MOFDM	Z

RADIATED EMISSION TEST (ABOVE 960 MHz):

- Pre-Scan has been conducted to determine the worst-case mode from all possible combinations between available modulations, XYZ axis and antenna ports (if EUT with antenna diversity architecture).
- Following channel(s) was (were) selected for the final test as listed below.

EUT CONFIGURE MODE	TESTED SUB-BAND	MODULATION TECHNOLOGY	AXIS
A ~ H	1 + 2 + 3	MOFDM	Z

UWB BANDWIDTH MEASUREMENT:

- Pre-Scan has been conducted to determine the worst-case mode from all possible combinations between available modulations and antenna ports (if EUT with antenna diversity architecture).
- Following channel(s) was (were) selected for the final test as listed below.

EUT CONFIGURE MODE	TESTED SUB-BAND	MODULATION TECHNOLOGY
A ~ H	1 + 2 + 3	MOFDM



A D T

PEAK EMISSION MEASUREMENT

- Pre-Scan has been conducted to determine the worst-case mode from all possible combinations between available modulations, XYZ axis and antenna ports (if EUT with antenna diversity architecture).
- Following channel(s) was (were) selected for the final test as listed below.

EUT CONFIGURE MODE	TESTED SUB-BAND	MODULATION TECHNOLOGY	AXIS
A ~ H	1 + 2 + 3	MOFDM	Z

3.2 GENERAL DESCRIPTION OF APPLIED STANDARDS

The EUT is a UWB product. According to the specifications of the manufacturer, it must comply with the requirements of the following standards:

FCC Part 15, Subpart F (15.519)

ANSI C63.4-2003

THE EVOLUTION OF MODERN UWB TECHNOLOGY

All test items have been performed and recorded as per the above standards.

NOTE: The EUT is also considered as a kind of computer peripheral, because the connection to computer is necessary for typical use. It has been verified to comply with the requirements of FCC Part 15, Subpart B, Class B (DoC). The test report has been issued separately.

3.3 DESCRIPTION OF SUPPORT UNITS

The EUT has been tested as an independent unit together with other necessary accessories or support units. The following support units or accessories were used to form a representative test configuration during the tests.

NO.	PRODUCT	BRAND	MODEL NO.	SERIAL NO.	FCC ID
1	NOTEBOOK COMPUTER	Asus	A8H	NA	FCC DoC Approved

NO.	SIGNAL CABLE DESCRIPTION OF THE ABOVE SUPPORT UNITS
1	NA

NOTE:

1. All power cords of the above support units are non-shielded (1.8m).
2. Item 1 was provided by Client.

CONFIGURATION OF SYSTEM UNDER TEST

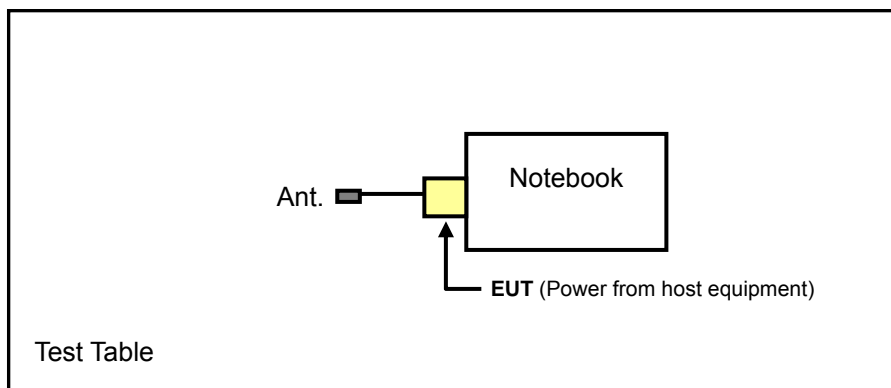

3.4 OPEARTIONAL LIMATIIONS

FCC 47 CFR Section 15.519(a)(1)

- (1) A UWB device operating under the provisions of this section shall transmit only when it is sending information to an associated receiver. The UWB intentional radiator shall cease transmission within 10 seconds unless it receives an acknowledgement from the associated receiver that its transmission is being received. An acknowledgment of reception must continue to be received by the UWB intentional radiator at least every 10 seconds or the UWB device must cease transmitting.

Client has been advised and showed on users manual.

FCC 47 CFR Section 15.519(a)(2)

- (2) The use of antennas mounted on outdoor structures, *e.g.*, antennas mounted on the outside of a building or on a telephone pole, or any fixed outdoors infrastructure is prohibited. Antennas may be mounted only on the hand held UWB device.

The antennas used in this product are Monopole and Inverted F antennas. These antennas will not be used and mounted on fixed structures.

FCC 47 CFR Section 15.519(a)(3)

- (3) UWB devices operating under the provisions of this section may operate indoors or outdoors.



4. TEST TYPES AND RESULTS

4.1 CONDUCTED EMISSION MEASUREMENT

4.1.1. LIMITS OF CONDUCTED EMISSION MEASUREMENT

FREQUENCY OF EMISSION (MHz)	CONDUCTED LIMIT (dB μ V)	
	Quasi-peak	Average
0.15-0.5	66 to 56	56 to 46
0.5-5	56	46
5-30	60	50

- NOTE:**
1. The lower limit shall apply at the transition frequencies.
 2. The limit decreases in line with the logarithm of the frequency in the range of 0.15 to 0.50 MHz.
 3. All emanations from a class A/B digital device or system, including any network of conductors and apparatus connected thereto, shall not exceed the level of field strengths specified above.

4.1.2. TEST INSTRUMENTS

DESCRIPTION & MANUFACTURER	MODEL NO.	SERIAL NO.	DATE OF CALIBRATION	DUE DATE OF CALIBRATION
Test Receiver ROHDE & SCHWARZ	ESCS30	100288	Sep. 22, 2008	Sep. 21, 2009
RF signal cable Woken	5D-FB	Cable-HYCO2-01	Dec. 31, 2008	Dec. 30, 2009
LISN ROHDE & SCHWARZ	ESH2-Z5	100100	Dec. 29, 2008	Dec. 28, 2009
LISN ROHDE & SCHWARZ	ESH3-Z5	100311	Jul. 30, 2008	Jul. 29, 2009
Software ADT	ADT_Cond_ V7.3.7	NA	NA	NA

- NOTE:**
1. The calibration interval of the above test instruments is 12 months and the calibrations are traceable to NML/ROC and NIST/USA.
 2. The test was performed in HwaYa Shielded Room 2.
 3. The VCCI Site Registration No. is C-2047.



A D T

4.1.3. TEST PROCEDURES

- a. The EUT was placed 0.4 meters from the conducting wall of the shielded room with EUT being connected to the power mains through a line impedance stabilization network (LISN). Other support units were connected to the power mains through another LISN. The two LISNs provide 50 ohm/ 50uH of coupling impedance for the measuring instrument.
- b. Both lines of the power mains connected to the EUT were checked for maximum conducted interference.
- c. The frequency range from 150kHz to 30MHz was searched. Emission levels under Limit - 20dB was not recorded.

4.1.4. DEVIATION FROM TEST STANDARD

No deviation

4.1.5. TEST SETUP

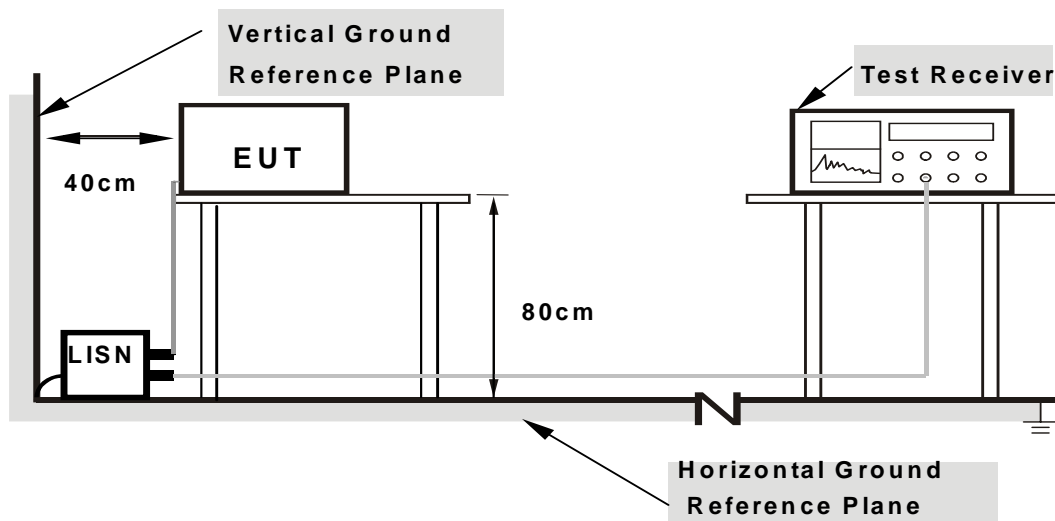

- Note: 1.Support units were connected to second LISN.**
2.Both of LISNs (AMN) are 80 cm from EUT and at least 80 from other units and other metal planes

For the actual test configuration, please refer to the attached file (Test Setup Photo).

4.1.6. EUT OPERATING CONDITIONS

- a. Connected the EUT to notebook and placed on a testing table.
- b. The notebook ran a test program (provided by manufacturer) to enable EUT under transmission condition continuously at specific channel frequency.

4.1.7. TEST RESULTS

CONDUCTED WORST-CASE DATA

EUT TEST CONDITION		MEASUREMENT DETAIL	
SUB-BAND	1 + 2 + 3	PHASE	Line 1
MODULATION TECHNOLOGY	MOFDM	6dB BANDWIDTH	9 kHz
ENVIRONMENTAL CONDITIONS	22 deg. C, 67 %RH, 991hPa	INPUT POWER (SYSTEM)	120Vac, 60 Hz
TESTED BY	Dean Wang	TEST MODE	A

No	Freq. [MHz]	Corr. Factor (dB)	Reading Value [dB (uV)]		Emission Level [dB (uV)]		Limit [dB (uV)]		Margin (dB)	
			Q.P.	AV.	Q.P.	AV.	Q.P.	AV.	Q.P.	AV.
			1	0.200	0.13	48.97	-	49.10	-	63.63
2	0.266	0.13	46.41	-	46.54	-	61.25	51.25	-14.70	-
3	0.332	0.14	40.13	-	40.27	-	59.39	49.39	-19.12	-
4	0.532	0.15	30.76	-	30.91	-	56.00	46.00	-25.09	-
5	4.577	0.29	33.07	-	33.36	-	56.00	46.00	-22.64	-
6	5.173	0.31	35.83	-	36.14	-	60.00	50.00	-23.86	-

- REMARKS:**
1. Q.P. and AV. are abbreviations of quasi-peak and average individually.
 2. "-": The Quasi-peak reading value also meets average limit and measurement with the average detector is unnecessary.
 3. The emission levels of other frequencies were very low against the limit.
 4. Margin value = Emission level - Limit value
 5. Correction factor = Insertion loss + Cable loss
 6. Emission Level = Correction Factor + Reading Value.

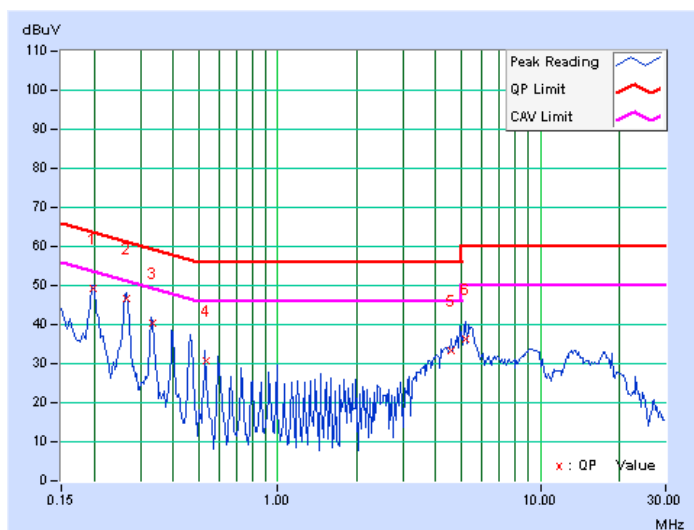



A D T

EUT TEST CONDITION		MEASUREMENT DETAIL	
SUB-BAND	1 + 2 + 3	PHASE	Line 2
MODULATION TECHNOLOGY	MOFDM	6dB BANDWIDTH	9 kHz
ENVIRONMENTAL CONDITIONS	22 deg. C, 67 %RH, 991hPa	INPUT POWER (SYSTEM)	120Vac, 60 Hz
TESTED BY	Dean Wang	TEST MODE	A

No	Freq. [MHz]	Corr. Factor (dB)	Reading Value		Emission Level		Limit		Margin	
			[dB (uV)]		[dB (uV)]		[dB (uV)]		(dB)	
			Q.P.	AV.	Q.P.	AV.	Q.P.	AV.	Q.P.	AV.
1	0.200	0.13	49.03	-	49.16	-	63.63	53.63	-14.47	-
2	0.267	0.14	45.72	-	45.86	-	61.20	51.20	-15.35	-
3	0.332	0.14	40.11	-	40.25	-	59.40	49.40	-19.14	-
4	0.531	0.15	31.10	-	31.25	-	56.00	46.00	-24.75	-
5	4.776	0.33	33.63	-	33.96	-	56.00	46.00	-22.04	-
6	5.439	0.35	36.61	-	36.96	-	60.00	50.00	-23.04	-

- REMARKS:**
1. Q.P. and AV. are abbreviations of quasi-peak and average individually.
 2. "-": The Quasi-peak reading value also meets average limit and measurement with the average detector is unnecessary.
 3. The emission levels of other frequencies were very low against the limit.
 4. Margin value = Emission level - Limit value
 5. Correction factor = Insertion loss + Cable loss
 6. Emission Level = Correction Factor + Reading Value.

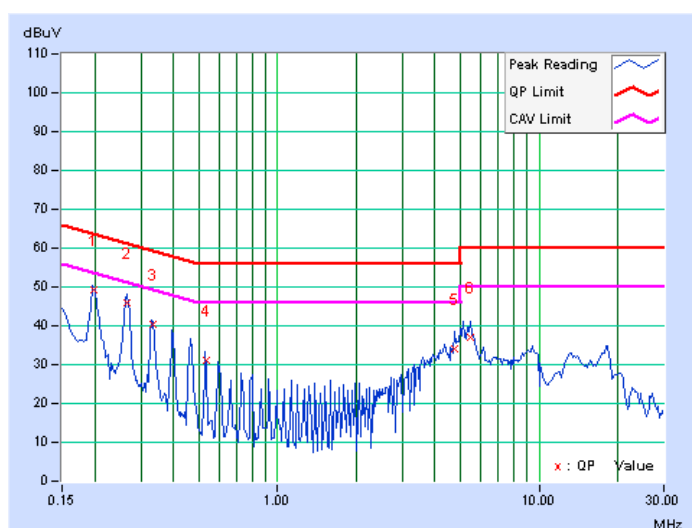



A D T

EUT TEST CONDITION		MEASUREMENT DETAIL	
SUB-BAND	1 + 2 + 3	PHASE	Line 1
MODULATION TECHNOLOGY	MOFDM	6dB BANDWIDTH	9 kHz
ENVIRONMENTAL CONDITIONS	22 deg. C, 67 %RH, 991hPa	INPUT POWER (SYSTEM)	120Vac, 60 Hz
TESTED BY	Dean Wang	TEST MODE	B

No	Freq. [MHz]	Corr.	Reading Value		Emission Level		Limit		Margin	
		Factor	[dB (uV)]		[dB (uV)]		[dB (uV)]		(dB)	
		(dB)	Q.P.	AV.	Q.P.	AV.	Q.P.	AV.	Q.P.	AV.
1	0.201	0.13	48.59	-	48.72	-	63.58	53.58	-14.86	-
2	0.266	0.13	46.43	-	46.56	-	61.24	51.24	-14.68	-
3	0.332	0.14	40.07	-	40.21	-	59.40	49.40	-19.19	-
4	0.532	0.15	30.30	-	30.45	-	56.00	46.00	-25.55	-
5	4.643	0.30	32.80	-	33.10	-	56.00	46.00	-22.90	-
6	5.173	0.31	35.68	-	35.99	-	60.00	50.00	-24.01	-

- REMARKS:**
1. Q.P. and AV. are abbreviations of quasi-peak and average individually.
 2. "-": The Quasi-peak reading value also meets average limit and measurement with the average detector is unnecessary.
 3. The emission levels of other frequencies were very low against the limit.
 4. Margin value = Emission level - Limit value
 5. Correction factor = Insertion loss + Cable loss
 6. Emission Level = Correction Factor + Reading Value.

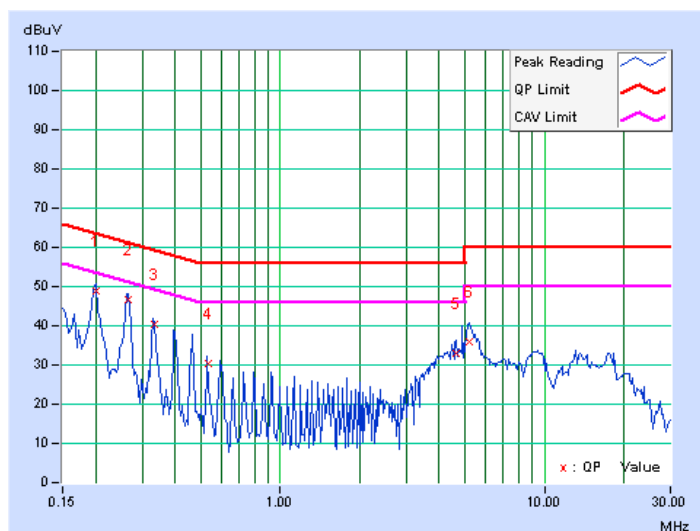



EUT TEST CONDITION		MEASUREMENT DETAIL	
SUB-BAND	1 + 2 + 3	PHASE	Line 2
MODULATION TECHNOLOGY	MOFDM	6dB BANDWIDTH	9 kHz
ENVIRONMENTAL CONDITIONS	22 deg. C, 67 %RH, 991hPa	INPUT POWER (SYSTEM)	120Vac, 60 Hz
TESTED BY	Dean Wang	TEST MODE	B

No	Freq. [MHz]	Corr. Factor [dB]	Reading Value [dB (uV)]		Emission Level [dB (uV)]		Limit [dB (uV)]		Margin (dB)	
			Q.P.	AV.	Q.P.	AV.	Q.P.	AV.	Q.P.	AV.
1	0.201	0.13	48.37	-	48.50	-	63.58	53.58	-15.08	-
2	0.266	0.14	46.25	-	46.39	-	61.23	51.23	-14.84	-
3	0.332	0.14	39.99	-	40.13	-	59.39	49.39	-19.26	-
4	0.532	0.15	30.98	-	31.13	-	56.00	46.00	-24.87	-
5	4.577	0.32	32.03	-	32.35	-	56.00	46.00	-23.65	-
6	5.240	0.34	35.99	-	36.33	-	60.00	50.00	-23.67	-

- REMARKS:**
1. Q.P. and AV. are abbreviations of quasi-peak and average individually.
 2. "-": The Quasi-peak reading value also meets average limit and measurement with the average detector is unnecessary.
 3. The emission levels of other frequencies were very low against the limit.
 4. Margin value = Emission level - Limit value
 5. Correction factor = Insertion loss + Cable loss
 6. Emission Level = Correction Factor + Reading Value.

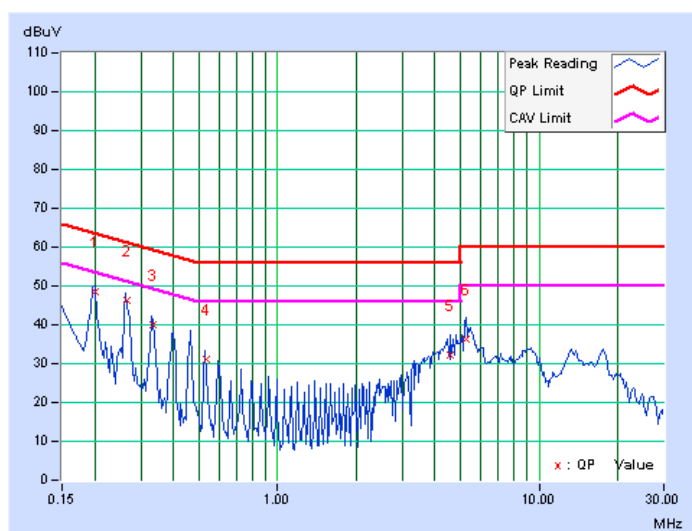

EUT TEST CONDITION		MEASUREMENT DETAIL	
SUB-BAND	1 + 2 + 3	PHASE	Line 1
MODULATION TECHNOLOGY	MOFDM	6dB BANDWIDTH	9 kHz
ENVIRONMENTAL CONDITIONS	22 deg. C, 67 %RH, 991hPa	INPUT POWER (SYSTEM)	120Vac, 60 Hz
TESTED BY	Dean Wang	TEST MODE	C

No	Freq. [MHz]	Corr. Factor (dB)	Reading Value [dB (uV)]		Emission Level [dB (uV)]		Limit [dB (uV)]		Margin (dB)	
			Q.P.	AV.	Q.P.	AV.	Q.P.	AV.	Q.P.	AV.
			1	0.199	0.13	50.93	-	51.06	-	63.64
2	0.266	0.13	45.48	-	45.61	-	61.24	51.24	-15.63	-
3	0.332	0.14	40.31	-	40.45	-	59.39	49.39	-18.95	-
4	0.597	0.15	31.56	-	31.71	-	56.00	46.00	-24.29	-
5	4.905	0.30	35.62	-	35.92	-	56.00	46.00	-20.08	-
6	5.436	0.32	38.45	-	38.77	-	60.00	50.00	-21.23	-

- REMARKS:**
1. Q.P. and AV. are abbreviations of quasi-peak and average individually.
 2. "-": The Quasi-peak reading value also meets average limit and measurement with the average detector is unnecessary.
 3. The emission levels of other frequencies were very low against the limit.
 4. Margin value = Emission level - Limit value
 5. Correction factor = Insertion loss + Cable loss
 6. Emission Level = Correction Factor + Reading Value.

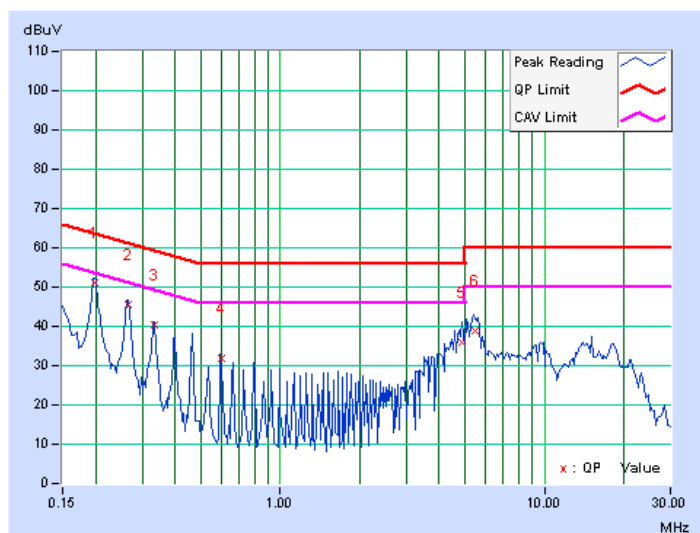

EUT TEST CONDITION		MEASUREMENT DETAIL	
SUB-BAND	1 + 2 + 3	PHASE	Line 2
MODULATION TECHNOLOGY	MOFDM	6dB BANDWIDTH	9 kHz
ENVIRONMENTAL CONDITIONS	22 deg. C, 67 %RH, 991hPa	INPUT POWER (SYSTEM)	120Vac, 60 Hz
TESTED BY	Dean Wang	TEST MODE	C

No	Freq. [MHz]	Corr. Factor (dB)	Reading Value [dB (uV)]		Emission Level [dB (uV)]		Limit [dB (uV)]		Margin (dB)	
			Q.P.	AV.	Q.P.	AV.	Q.P.	AV.	Q.P.	AV.
1	0.199	0.13	51.14	-	51.27	-	63.63	53.63	-12.36	-
2	0.266	0.14	45.16	-	45.30	-	61.24	51.24	-15.95	-
3	0.331	0.14	40.29	-	40.43	-	59.42	49.42	-18.99	-
4	0.597	0.16	30.52	-	30.68	-	56.00	46.00	-25.32	-
5	4.703	0.32	35.12	-	35.44	-	56.00	46.00	-20.56	-
6	5.564	0.35	39.76	-	40.11	-	60.00	50.00	-19.89	-

- REMARKS:**
1. Q.P. and AV. are abbreviations of quasi-peak and average individually.
 2. "-": The Quasi-peak reading value also meets average limit and measurement with the average detector is unnecessary.
 3. The emission levels of other frequencies were very low against the limit.
 4. Margin value = Emission level - Limit value
 5. Correction factor = Insertion loss + Cable loss
 6. Emission Level = Correction Factor + Reading Value.

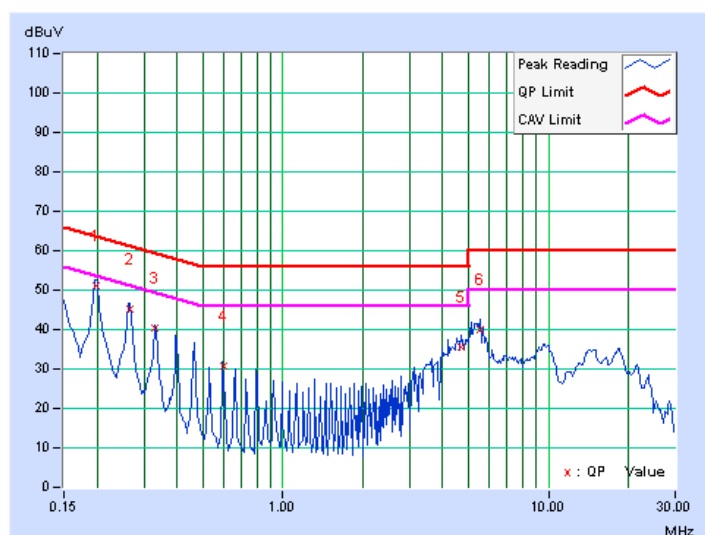

EUT TEST CONDITION		MEASUREMENT DETAIL	
SUB-BAND	1 + 2 + 3	PHASE	Line 1
MODULATION TECHNOLOGY	MOFDM	6dB BANDWIDTH	9 kHz
ENVIRONMENTAL CONDITIONS	22 deg. C, 67 %RH, 991hPa	INPUT POWER (SYSTEM)	120Vac, 60 Hz
TESTED BY	Dean Wang	TEST MODE	D

No	Freq. [MHz]	Corr. Factor (dB)	Reading Value		Emission Level		Limit		Margin	
			[dB (uV)]		[dB (uV)]		[dB (uV)]		(dB)	
			Q.P.	AV.	Q.P.	AV.	Q.P.	AV.	Q.P.	AV.
1	0.200	0.13	50.55	-	50.68	-	63.63	53.63	-12.95	-
2	0.266	0.13	45.86	-	45.99	-	61.24	51.24	-15.25	-
3	0.332	0.14	40.81	-	40.95	-	59.39	49.39	-18.45	-
4	0.532	0.15	28.10	-	28.25	-	56.00	46.00	-27.75	-
5	4.512	0.29	32.92	-	33.21	-	56.00	46.00	-22.79	-
6	5.241	0.31	38.93	-	39.24	-	60.00	50.00	-20.76	-

- REMARKS:**
1. Q.P. and AV. are abbreviations of quasi-peak and average individually.
 2. "-": The Quasi-peak reading value also meets average limit and measurement with the average detector is unnecessary.
 3. The emission levels of other frequencies were very low against the limit.
 4. Margin value = Emission level - Limit value
 5. Correction factor = Insertion loss + Cable loss
 6. Emission Level = Correction Factor + Reading Value.

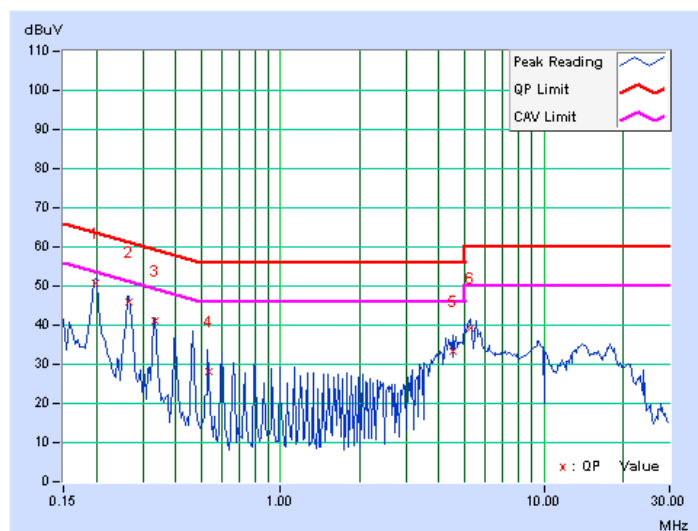



EUT TEST CONDITION		MEASUREMENT DETAIL	
SUB-BAND	1 + 2 + 3	PHASE	Line 2
MODULATION TECHNOLOGY	MOFDM	6dB BANDWIDTH	9 kHz
ENVIRONMENTAL CONDITIONS	22 deg. C, 67 %RH, 991hPa	INPUT POWER (SYSTEM)	120Vac, 60 Hz
TESTED BY	Dean Wang	TEST MODE	D

No	Freq. [MHz]	Corr. Factor [dB]	Reading Value [dB (uV)]		Emission Level [dB (uV)]		Limit [dB (uV)]		Margin (dB)	
			Q.P.	AV.	Q.P.	AV.	Q.P.	AV.	Q.P.	AV.
			1	0.200	0.13	50.61	-	50.74	-	63.63
2	0.266	0.14	45.86	-	46.00	-	61.25	51.25	-15.25	-
3	0.333	0.14	40.63	-	40.77	-	59.39	49.39	-18.61	-
4	0.597	0.16	31.91	-	32.07	-	56.00	46.00	-23.93	-
5	4.842	0.33	34.40	-	34.73	-	56.00	46.00	-21.27	-
6	5.174	0.34	36.79	-	37.13	-	60.00	50.00	-22.87	-

- REMARKS:**
1. Q.P. and AV. are abbreviations of quasi-peak and average individually.
 2. "-": The Quasi-peak reading value also meets average limit and measurement with the average detector is unnecessary.
 3. The emission levels of other frequencies were very low against the limit.
 4. Margin value = Emission level - Limit value
 5. Correction factor = Insertion loss + Cable loss
 6. Emission Level = Correction Factor + Reading Value.

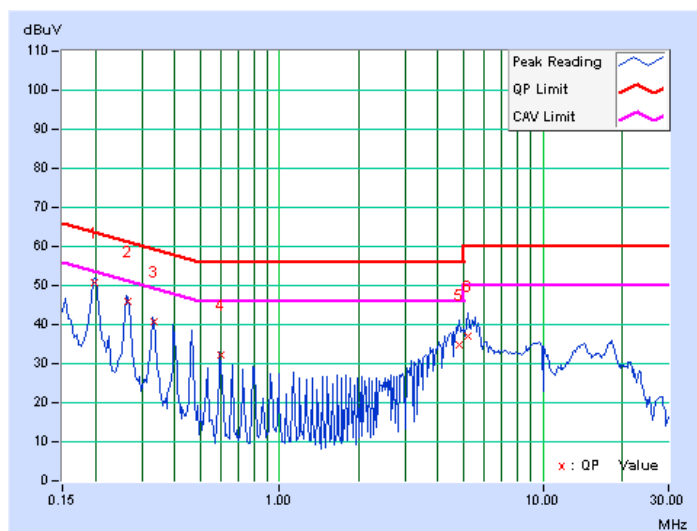



A D T

EUT TEST CONDITION		MEASUREMENT DETAIL	
SUB-BAND	1 + 2 + 3	PHASE	Line 1
MODULATION TECHNOLOGY	MOFDM	6dB BANDWIDTH	9 kHz
ENVIRONMENTAL CONDITIONS	22 deg. C, 67 %RH, 991hPa	INPUT POWER (SYSTEM)	120Vac, 60 Hz
TESTED BY	Dean Wang	TEST MODE	E

No	Freq. [MHz]	Corr. Factor (dB)	Reading Value		Emission Level		Limit		Margin	
			[dB (uV)]		[dB (uV)]		[dB (uV)]		(dB)	
			Q.P.	AV.	Q.P.	AV.	Q.P.	AV.	Q.P.	AV.
1	0.201	0.13	48.51	-	48.64	-	63.58	53.58	-14.94	-
2	0.266	0.13	46.43	-	46.56	-	61.25	51.25	-14.68	-
3	0.334	0.14	39.65	-	39.79	-	59.36	49.36	-19.57	-
4	0.599	0.15	29.50	-	29.65	-	56.00	46.00	-26.35	-
5	4.777	0.30	32.86	-	33.16	-	56.00	46.00	-22.84	-
6	5.374	0.31	36.19	-	36.50	-	60.00	50.00	-23.50	-

- REMARKS:**
1. Q.P. and AV. are abbreviations of quasi-peak and average individually.
 2. "-": The Quasi-peak reading value also meets average limit and measurement with the average detector is unnecessary.
 3. The emission levels of other frequencies were very low against the limit.
 4. Margin value = Emission level - Limit value
 5. Correction factor = Insertion loss + Cable loss
 6. Emission Level = Correction Factor + Reading Value.

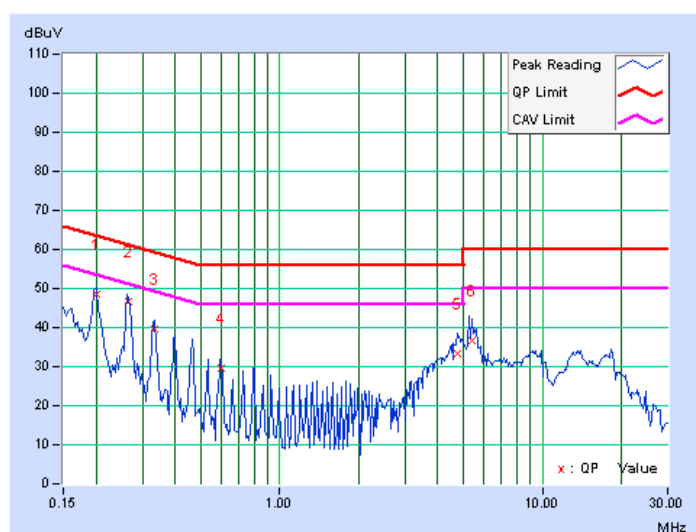



A D T

EUT TEST CONDITION		MEASUREMENT DETAIL	
SUB-BAND	1 + 2 + 3	PHASE	Line 2
MODULATION TECHNOLOGY	MOFDM	6dB BANDWIDTH	9 kHz
ENVIRONMENTAL CONDITIONS	22 deg. C, 67 %RH, 991hPa	INPUT POWER (SYSTEM)	120Vac, 60 Hz
TESTED BY	Dean Wang	TEST MODE	E

No	Freq. [MHz]	Corr. Factor (dB)	Reading Value		Emission Level		Limit		Margin	
			[dB (uV)]		[dB (uV)]		[dB (uV)]		(dB)	
			Q.P.	AV.	Q.P.	AV.	Q.P.	AV.	Q.P.	AV.
1	0.201	0.13	48.49	-	48.62	-	63.58	53.58	-14.96	-
2	0.267	0.14	45.80	-	45.94	-	61.21	51.21	-15.27	-
3	0.334	0.14	39.38	-	39.52	-	59.36	49.36	-19.84	-
4	0.530	0.15	31.50	-	31.65	-	56.00	46.00	-24.35	-
5	4.711	0.32	33.03	-	33.35	-	56.00	46.00	-22.65	-
6	5.309	0.34	35.26	-	35.60	-	60.00	50.00	-24.40	-

- REMARKS:**
1. Q.P. and AV. are abbreviations of quasi-peak and average individually.
 2. "-": The Quasi-peak reading value also meets average limit and measurement with the average detector is unnecessary.
 3. The emission levels of other frequencies were very low against the limit.
 4. Margin value = Emission level - Limit value
 5. Correction factor = Insertion loss + Cable loss
 6. Emission Level = Correction Factor + Reading Value.

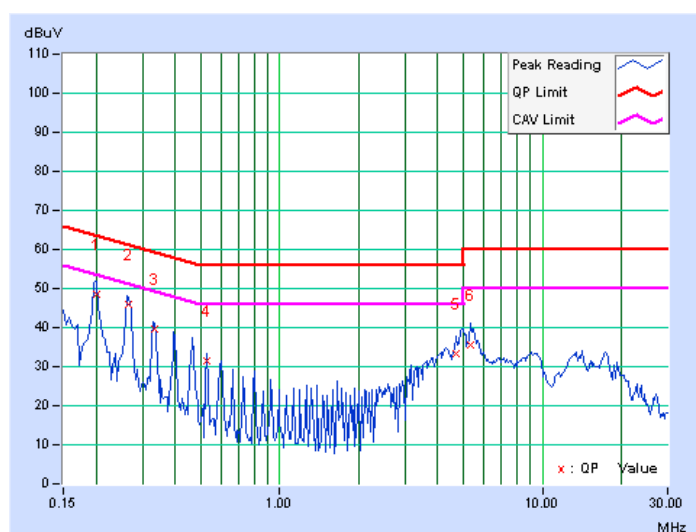

EUT TEST CONDITION		MEASUREMENT DETAIL	
SUB-BAND	1 + 2 + 3	PHASE	Line 1
MODULATION TECHNOLOGY	MOFDM	6dB BANDWIDTH	9 kHz
ENVIRONMENTAL CONDITIONS	22 deg. C, 67 %RH, 991hPa	INPUT POWER (SYSTEM)	120Vac, 60 Hz
TESTED BY	Dean Wang	TEST MODE	F

No	Freq. [MHz]	Corr.	Reading Value		Emission Level		Limit		Margin	
		Factor	[dB (uV)]		[dB (uV)]		[dB (uV)]		(dB)	
		(dB)	Q.P.	AV.	Q.P.	AV.	Q.P.	AV.	Q.P.	AV.
1	0.200	0.13	48.91	-	49.04	-	63.63	53.63	-14.59	-
2	0.266	0.13	46.43	-	46.56	-	61.24	51.24	-14.68	-
3	0.332	0.14	40.25	-	40.39	-	59.40	49.40	-19.01	-
4	0.532	0.15	30.80	-	30.95	-	56.00	46.00	-25.05	-
5	4.842	0.30	33.84	-	34.14	-	56.00	46.00	-21.86	-
6	5.375	0.31	35.99	-	36.30	-	60.00	50.00	-23.70	-

- REMARKS:**
1. Q.P. and AV. are abbreviations of quasi-peak and average individually.
 2. "-": The Quasi-peak reading value also meets average limit and measurement with the average detector is unnecessary.
 3. The emission levels of other frequencies were very low against the limit.
 4. Margin value = Emission level - Limit value
 5. Correction factor = Insertion loss + Cable loss
 6. Emission Level = Correction Factor + Reading Value.

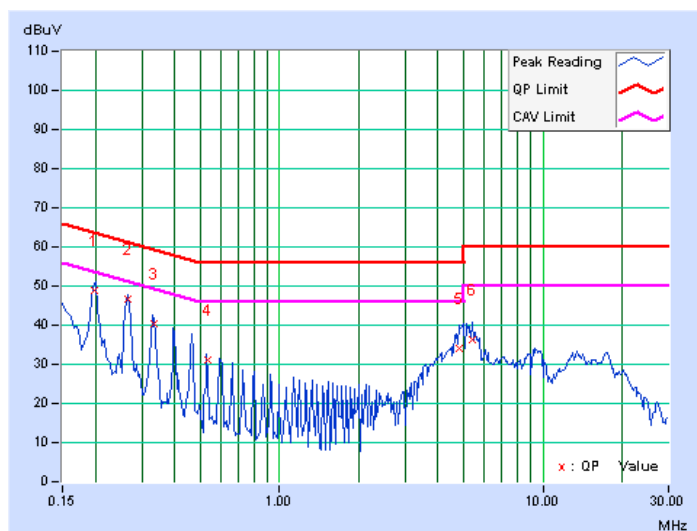



A D T

EUT TEST CONDITION		MEASUREMENT DETAIL	
SUB-BAND	1 + 2 + 3	PHASE	Line 2
MODULATION TECHNOLOGY	MOFDM	6dB BANDWIDTH	9 kHz
ENVIRONMENTAL CONDITIONS	22 deg. C, 67 %RH, 991hPa	INPUT POWER (SYSTEM)	120Vac, 60 Hz
TESTED BY	Dean Wang	TEST MODE	F

No	Freq. [MHz]	Corr. Factor (dB)	Reading Value [dB (uV)]		Emission Level [dB (uV)]		Limit [dB (uV)]		Margin (dB)	
			Q.P.	AV.	Q.P.	AV.	Q.P.	AV.	Q.P.	AV.
1	0.201	0.13	48.29	-	48.42	-	63.58	53.58	-15.16	-
2	0.266	0.14	46.45	-	46.59	-	61.25	51.25	-14.66	-
3	0.334	0.14	39.36	-	39.50	-	59.36	49.36	-19.86	-
4	0.531	0.15	30.72	-	30.87	-	56.00	46.00	-25.13	-
5	4.644	0.32	32.00	-	32.32	-	56.00	46.00	-23.68	-
6	5.174	0.34	35.26	-	35.60	-	60.00	50.00	-24.40	-

- REMARKS:**
1. Q.P. and AV. are abbreviations of quasi-peak and average individually.
 2. "-": The Quasi-peak reading value also meets average limit and measurement with the average detector is unnecessary.
 3. The emission levels of other frequencies were very low against the limit.
 4. Margin value = Emission level - Limit value
 5. Correction factor = Insertion loss + Cable loss
 6. Emission Level = Correction Factor + Reading Value.

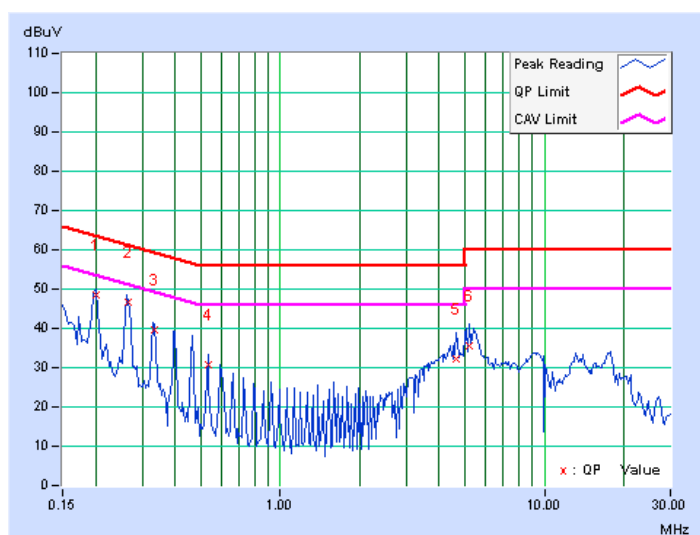

EUT TEST CONDITION		MEASUREMENT DETAIL	
SUB-BAND	1 + 2 + 3	PHASE	Line 1
MODULATION TECHNOLOGY	MOFDM	6dB BANDWIDTH	9 kHz
ENVIRONMENTAL CONDITIONS	22 deg. C, 67 %RH, 991hPa	INPUT POWER (SYSTEM)	120Vac, 60 Hz
TESTED BY	Dean Wang	TEST MODE	G

No	Freq. [MHz]	Corr. Factor (dB)	Reading Value [dB (uV)]		Emission Level [dB (uV)]		Limit [dB (uV)]		Margin (dB)	
			Q.P.	AV.	Q.P.	AV.	Q.P.	AV.	Q.P.	AV.
1	0.201	0.13	48.70	-	48.83	-	63.58	53.58	-14.75	-
2	0.267	0.13	45.74	-	45.87	-	61.20	51.20	-15.33	-
3	0.334	0.14	39.46	-	39.60	-	59.36	49.36	-19.76	-
4	0.532	0.15	30.37	-	30.52	-	56.00	46.00	-25.48	-
5	4.842	0.30	33.95	-	34.25	-	56.00	46.00	-21.75	-
6	5.309	0.31	35.86	-	36.17	-	60.00	50.00	-23.83	-

- REMARKS:**
1. Q.P. and AV. are abbreviations of quasi-peak and average individually.
 2. "-": The Quasi-peak reading value also meets average limit and measurement with the average detector is unnecessary.
 3. The emission levels of other frequencies were very low against the limit.
 4. Margin value = Emission level - Limit value
 5. Correction factor = Insertion loss + Cable loss
 6. Emission Level = Correction Factor + Reading Value.

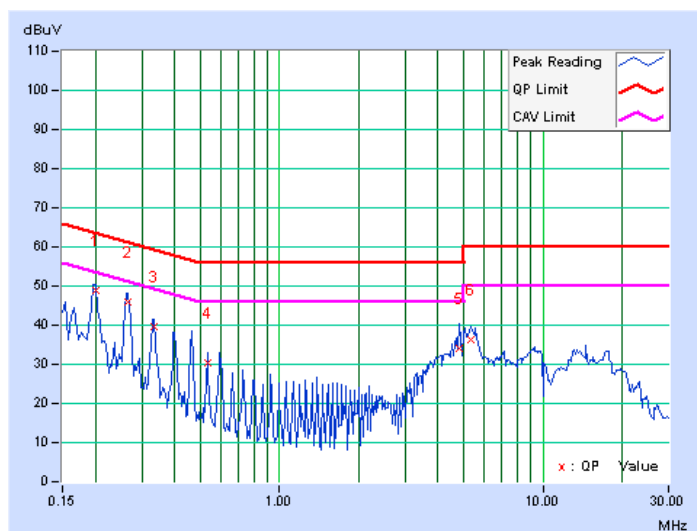

EUT TEST CONDITION		MEASUREMENT DETAIL	
SUB-BAND	1 + 2 + 3	PHASE	Line 2
MODULATION TECHNOLOGY	MOFDM	6dB BANDWIDTH	9 kHz
ENVIRONMENTAL CONDITIONS	22 deg. C, 67 %RH, 991hPa	INPUT POWER (SYSTEM)	120Vac, 60 Hz
TESTED BY	Dean Wang	TEST MODE	G

No	Freq. [MHz]	Corr. Factor (dB)	Reading Value		Emission Level		Limit		Margin	
			[dB (uV)]		[dB (uV)]		[dB (uV)]		(dB)	
			Q.P.	AV.	Q.P.	AV.	Q.P.	AV.	Q.P.	AV.
1	0.201	0.13	48.37	-	48.50	-	63.58	53.58	-15.08	-
2	0.266	0.14	46.49	-	46.63	-	61.25	51.25	-14.62	-
3	0.334	0.14	39.34	-	39.48	-	59.36	49.36	-19.88	-
4	0.531	0.15	30.44	-	30.59	-	56.00	46.00	-25.41	-
5	4.777	0.33	32.44	-	32.77	-	56.00	46.00	-23.23	-
6	5.307	0.34	36.23	-	36.57	-	60.00	50.00	-23.43	-

- REMARKS:**
1. Q.P. and AV. are abbreviations of quasi-peak and average individually.
 2. "-": The Quasi-peak reading value also meets average limit and measurement with the average detector is unnecessary.
 3. The emission levels of other frequencies were very low against the limit.
 4. Margin value = Emission level - Limit value
 5. Correction factor = Insertion loss + Cable loss
 6. Emission Level = Correction Factor + Reading Value.

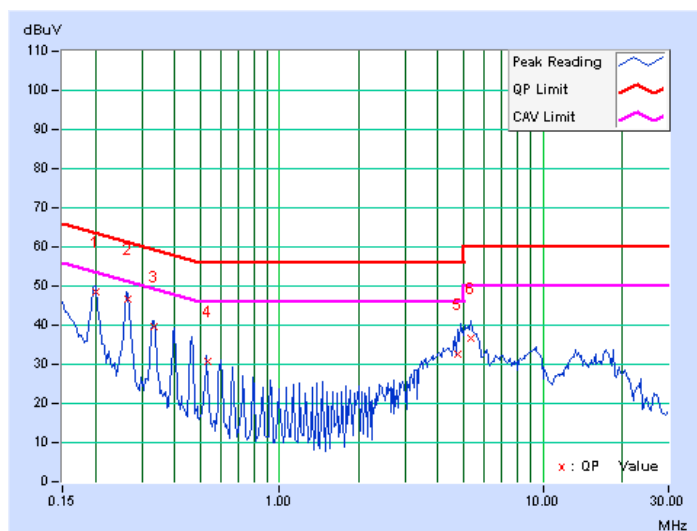

EUT TEST CONDITION		MEASUREMENT DETAIL	
SUB-BAND	1 + 2 + 3	PHASE	Line 1
MODULATION TECHNOLOGY	MOFDM	6dB BANDWIDTH	9 kHz
ENVIRONMENTAL CONDITIONS	22 deg. C, 67 %RH, 991hPa	INPUT POWER (SYSTEM)	120Vac, 60 Hz
TESTED BY	Dean Wang	TEST MODE	H

No	Freq. [MHz]	Corr.	Reading Value		Emission Level		Limit		Margin	
		Factor	[dB (uV)]		[dB (uV)]		[dB (uV)]		(dB)	
		(dB)	Q.P.	AV.	Q.P.	AV.	Q.P.	AV.	Q.P.	AV.
1	0.201	0.13	48.37	-	48.50	-	63.58	53.58	-15.08	-
2	0.266	0.13	46.43	-	46.56	-	61.24	51.24	-14.68	-
3	0.332	0.14	40.21	-	40.35	-	59.39	49.39	-19.05	-
4	0.532	0.15	30.34	-	30.49	-	56.00	46.00	-25.51	-
5	4.777	0.30	33.29	-	33.59	-	56.00	46.00	-22.41	-
6	5.240	0.31	36.25	-	36.56	-	60.00	50.00	-23.44	-

- REMARKS:**
1. Q.P. and AV. are abbreviations of quasi-peak and average individually.
 2. "-": The Quasi-peak reading value also meets average limit and measurement with the average detector is unnecessary.
 3. The emission levels of other frequencies were very low against the limit.
 4. Margin value = Emission level - Limit value
 5. Correction factor = Insertion loss + Cable loss
 6. Emission Level = Correction Factor + Reading Value.

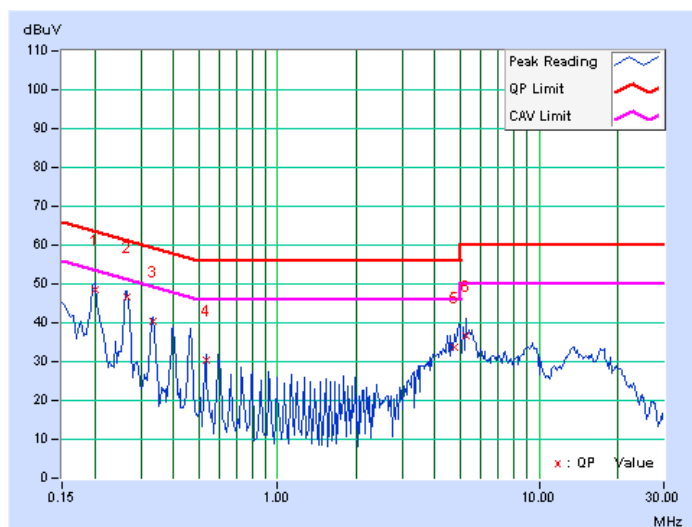



A D T

EUT TEST CONDITION		MEASUREMENT DETAIL	
SUB-BAND	1 + 2 + 3	PHASE	Line 2
MODULATION TECHNOLOGY	MOFDM	6dB BANDWIDTH	9 kHz
ENVIRONMENTAL CONDITIONS	22 deg. C, 67 %RH, 991hPa	INPUT POWER (SYSTEM)	120Vac, 60 Hz
TESTED BY	Dean Wang	TEST MODE	H

No	Freq. [MHz]	Corr. Factor (dB)	Reading Value [dB (uV)]		Emission Level [dB (uV)]		Limit [dB (uV)]		Margin (dB)	
			Q.P.	AV.	Q.P.	AV.	Q.P.	AV.	Q.P.	AV.
1	0.200	0.13	48.91	-	49.04	-	63.61	53.61	-14.57	-
2	0.267	0.14	45.84	-	45.98	-	61.20	51.20	-15.23	-
3	0.333	0.14	39.73	-	39.87	-	59.38	49.38	-19.51	-
4	0.533	0.15	30.06	-	30.21	-	56.00	46.00	-25.79	-
5	4.844	0.33	32.95	-	33.28	-	56.00	46.00	-22.72	-
6	5.108	0.34	34.60	-	34.94	-	60.00	50.00	-25.06	-

- REMARKS:**
1. Q.P. and AV. are abbreviations of quasi-peak and average individually.
 2. "-": The Quasi-peak reading value also meets average limit and measurement with the average detector is unnecessary.
 3. The emission levels of other frequencies were very low against the limit.
 4. Margin value = Emission level - Limit value
 5. Correction factor = Insertion loss + Cable loss
 6. Emission Level = Correction Factor + Reading Value.

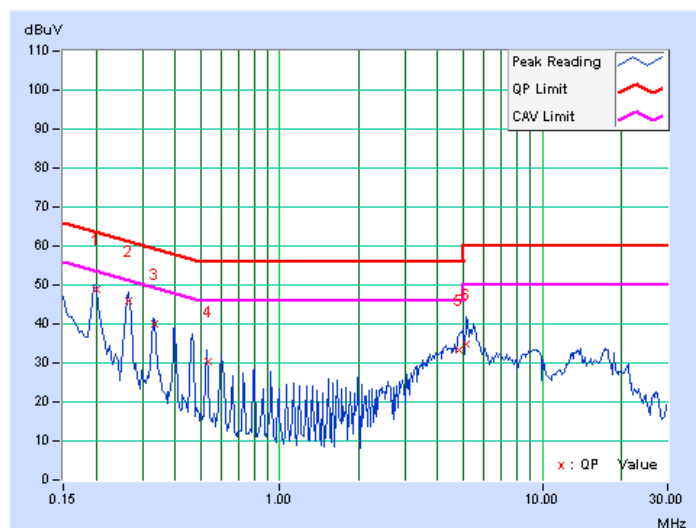



4.2 RADIATED EMISSION MEASUREMENT (FOR 15.519 (c))

4.2.1 LIMITS OF RADIATED EMISSION MEASUREMENT

The radiated emissions at or below 960MHz from a device operating under the provisions of this section shall not exceed the emission levels in Section 15.209.

FREQUENCIES (MHz)	FIELD STRENGTH (mV/m)	MEASUREMENT DISTANCE (m)
0.009 ~ 0.490	2400/F(kHz)	300
0.490 ~ 1.705	24000/F(kHz)	30
1.705 ~ 30.0	30	30
30 ~ 88	100	3
88 ~ 216	150	3
216 ~ 960	200	3

NOTE: 1. The lower limit shall apply at the transition frequencies.

2. Emission level (dBuV/m) = 20 log Emission level (uV/m).

The radiated emissions above 960MHz from a device operating under the provisions of this section shall not exceed the following average limits when measured using a resolution bandwidth of 1MHz:

FREQUENCY IN MHz	EIRP IN dBm	dBuV/m@3m	dBuV/m@1m
960 ~ 1,610	-75.3	19.9	29.44
1,610 ~ 1,990	-63.3	31.9	41.44
1,990 ~ 3,100	-61.3	33.9	43.44
3,100 ~ 10,600	-41.3	53.9	63.44
Above 10600	-61.3	33.9	43.44

Transfer rules follow 15.521(g),15.31(f)(1).



15.521(c) Emissions from digital circuitry used to enable the operation of the UWB transmitter shall comply with the limits in Section 15.209 of this chapter, rather than the limits specified in this subpart.

NOTE: Use conducted measurement to determine emissions is from digital circuitry or not.
Emissions from digital circuitry follow 15.209.

The radiated emissions from a device operating under the provisions of this section shall not exceed the emission levels in Section 15.209.

FREQUENCY IN MHz	dBuV/m@3m	dBuV/m@1m
	Quasi Peak	Quasi Peak
216 ~ 960	46.00	55.54
960 ~ 1000	54.00	63.54

FREQUENCY IN MHz	dBuV/m@3m		dBuV/m@1m	
Above 1000	Peak	Average	Peak	Average
	74.00	54.00	83.54	63.54

4.2.2 INSTRUMENT SETUP VALUE AND MEASUREMENT DISTANCE

FREQUENCY RANGE	RESOLUTION BANDWIDTH	VIDEO BANDWIDTH	DETECTOR	MEASUREMENT DISTANCE
Below 960MHz	120kHz	120kHz	Quasi Peak	3 meters
Above 960MHz	1MHz	3MHz	RMS	1 meter



4.2.3 TEST INSTRUMENTS

DESCRIPTION & MANUFACTURER	MODEL NO.	SERIAL NO.	DATE OF CALIBRATION	DUE DATE OF CALIBRATION
Test Receiver ROHDE & SCHWARZ	ESI7	100033	Jun. 30, 2008	Jun. 29, 2009
Spectrum Analyzer ROHDE & SCHWARZ	FSP40	100040	Jul. 04, 2008	Jul. 03, 2009
BILOG Antenna SCHWARZBECK	VULB9168	9168-160	Apr. 28, 2008	Apr. 27, 2009
HORN Antenna SCHWARZBECK	9120D	9120D-209	Jun. 24, 2008	Jun. 23, 2009
HORN Antenna SCHWARZBECK	BBHA 9170	BBHA9170243	Dec. 25, 2008	Dec. 24, 2009
Preamplifier Agilent	8447D	2944A10633	Nov. 03, 2008	Nov. 02, 2009
Preamplifier Agilent	8449B	3008A01964	Oct. 23, 2008	Oct. 22, 2009
RF signal cable HUBER+SUHNNER	SUCOFLEX 104	238141/4	May 20, 2008	May 19, 2009
RF signal cable HUBER+SUHNNER	SUCOFLEX 104	12738/6	May 20, 2008	May 19, 2009
Software ADT.	ADT_Radiated_ V7.6.15.9.2	NA	NA	NA
Antenna Tower inn-co GmbH	MA 4000	013303	NA	NA
Antenna Tower Controller inn-co GmbH	CO2000	017303	NA	NA
Turn Table ADT.	TT100.	TT93021703	NA	NA
Turn Table Controller ADT.	SC100.	SC93021703	NA	NA

- NOTE:** 1. The calibration interval of the above test instruments is 12 months and the calibrations are traceable to NML/ROC and NIST/USA.
2. The test was performed in HwaYa Chamber 3.
3. The horn antenna and HP preamplifier (model: 8449B) are used only for the measurement of emission frequency above 1GHz if tested.
4. The FCC Site Registration No. is 988962.
5. The IC Site Registration No. is IC 7450F-3.



A D T

4.2.4 TEST PROCEDURES

- a. The EUT was placed on the top of a rotating table 0.8 meters above the ground at a 3 meters semi-anechoic chamber. The table was rotated 360 degrees to determine the position of the highest radiation.
- b. The EUT was set 1, 3 meters away from the interference-receiving antenna, which was mounted on the top of a variable-height antenna tower.
- c. The antenna is a broadband antenna, and its height is varied from one meter to four meters above the ground to determine the maximum value of the field strength. Both horizontal and vertical polarizations of the antenna are set to make the measurement.
- d. For each suspected emission, the EUT was arranged to its worst case and then the antenna was tuned to heights from 1 meter to 4 meters and the rotatable table was turned from 0 degrees to 360 degrees to find the maximum reading.

4.2.5 DEVIATION FROM TEST STANDARD

No deviation

4.2.6 TEST SETUP

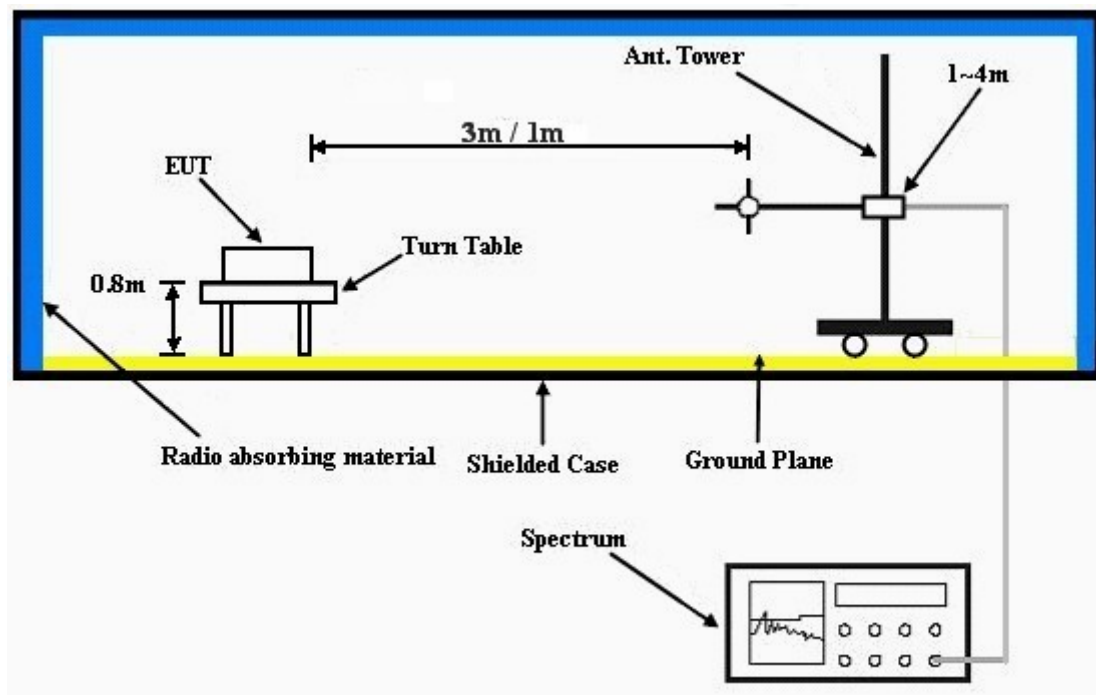

For the actual test configuration, please refer to the attached file (Test Setup Photo).

4.2.7 EUT OPERATING CONDITIONS

Same as 4.1.6



4.2.8 TEST RESULTS

RADIATED BELOW 960MHz WORST-CASE DATA

EUT TEST CONDITION		MEASUREMENT DETAIL	
SUB-BAND	1 + 2 + 3	FREQUENCY RANGE	Below 960MHz
MODULATION TECHNOLOGY	MOFDM	DETECTOR FUNCTION	Quasi-Peak
ENVIRONMENTAL CONDITIONS	25 deg. C, 65 %RH, 988hPa	INPUT POWER (SYSTEM)	120Vac, 60 Hz
TESTED BY	Dean Wang	TEST MODE	A

ANTENNA POLARITY & TEST DISTANCE: HORIZONTAL AT 3 M								
NO.	FREQ. (MHz)	EMISSION LEVEL (dBuV/m)	LIMIT (dBuV/m)	MARGIN (dB)	ANTENNA HEIGHT (m)	TABLE ANGLE (Degree)	RAW VALUE (dBuV)	CORRECTION FACTOR (dB/m)
1	98.96	40.47 QP	43.50	-3.03	2.50 H	214	29.26	11.22
2	166.05	33.80 QP	43.50	-9.70	2.50 H	85	19.85	13.95
3	298.38	35.32 QP	46.00	-10.68	1.00 H	343	21.59	13.73
4	426.97	41.81 QP	46.00	-4.19	2.00 H	250	23.09	18.72
5	479.16	36.41 QP	46.00	-9.59	2.00 H	184	16.45	19.96
6	801.58	40.24 QP	46.00	-5.76	1.00 H	142	14.19	26.05
ANTENNA POLARITY & TEST DISTANCE: VERTICAL AT 3 M								
NO.	FREQ. (MHz)	EMISSION LEVEL (dBuV/m)	LIMIT (dBuV/m)	MARGIN (dB)	ANTENNA HEIGHT (m)	TABLE ANGLE (Degree)	RAW VALUE (dBuV)	CORRECTION FACTOR (dB/m)
1	98.96	35.85 QP	43.50	-7.65	1.00 V	154	24.63	11.22
2	266.69	39.69 QP	46.00	-6.31	1.50 V	154	25.91	13.78
3	365.47	35.34 QP	46.00	-10.66	1.25 V	172	18.74	16.60
4	426.97	40.77 QP	46.00	-5.23	1.00 V	205	22.04	18.72
5	479.16	37.55 QP	46.00	-8.45	1.00 V	283	17.60	19.96
6	801.58	40.03 QP	46.00	-5.97	1.00 V	256	13.98	26.05
7	812.77	35.58 QP	46.00	-10.42	1.25 V	217	9.33	26.25

- REMARKS:**
1. Emission level (dBuV/m) = Raw Value (dBuV) + Correction Factor (dB/m).
 2. Correction Factor (dB/m) = Antenna Factor (dB/m) + Cable Factor (dB).
 3. The other emission levels were very low against the limit.
 4. Margin value = Emission level – Limit value.



A D T

EUT TEST CONDITION		MEASUREMENT DETAIL	
SUB-BAND	1 + 2 + 3	FREQUENCY RANGE	Below 960MHz
MODULATION TECHNOLOGY	MOFDM	DETECTOR FUNCTION	Quasi-Peak
ENVIRONMENTAL CONDITIONS	25 deg. C, 65 %RH, 988hPa	INPUT POWER (SYSTEM)	120Vac, 60 Hz
TESTED BY	Dean Wang	TEST MODE	B

ANTENNA POLARITY & TEST DISTANCE: HORIZONTAL AT 3 M								
NO.	FREQ. (MHz)	EMISSION LEVEL (dBuV/m)	LIMIT (dBuV/m)	MARGIN (dB)	ANTENNA HEIGHT (m)	TABLE ANGLE (Degree)	RAW VALUE (dBuV)	CORRECTION FACTOR (dB/m)
1	99.89	40.85 QP	43.50	-2.65	2.50 H	232	29.29	11.56
2	166.00	33.88 QP	43.50	-9.62	2.50 H	88	19.93	13.95
3	239.88	35.24 QP	46.00	-10.76	1.25 H	22	22.09	13.15
4	298.21	35.34 QP	46.00	-10.66	1.00 H	334	21.61	13.73
5	428.48	41.40 QP	46.00	-4.60	2.00 H	250	22.64	18.76
6	479.03	35.04 QP	46.00	-10.96	2.00 H	172	15.09	19.96
7	799.84	40.29 QP	46.00	-5.71	1.00 H	10	14.27	26.02
ANTENNA POLARITY & TEST DISTANCE: VERTICAL AT 3 M								
NO.	FREQ. (MHz)	EMISSION LEVEL (dBuV/m)	LIMIT (dBuV/m)	MARGIN (dB)	ANTENNA HEIGHT (m)	TABLE ANGLE (Degree)	RAW VALUE (dBuV)	CORRECTION FACTOR (dB/m)
1	98.96	36.35 QP	43.50	-7.15	1.00 V	190	25.13	11.22
2	365.47	35.37 QP	46.00	-10.63	1.50 V	163	18.77	16.60
3	426.97	40.78 QP	46.00	-5.22	1.00 V	217	22.06	18.72
4	479.16	36.88 QP	46.00	-9.12	1.00 V	301	16.92	19.96
5	801.58	40.87 QP	46.00	-5.13	1.00 V	241	14.82	26.05
6	812.77	35.86 QP	46.00	-10.14	1.25 V	232	9.61	26.25

- REMARKS:**
1. Emission level (dBuV/m) = Raw Value (dBuV) + Correction Factor (dB/m).
 2. Correction Factor (dB/m) = Antenna Factor (dB/m) + Cable Factor (dB).
 3. The other emission levels were very low against the limit.
 4. Margin value = Emission level – Limit value.



A D T

EUT TEST CONDITION		MEASUREMENT DETAIL	
SUB-BAND	1 + 2 + 3	FREQUENCY RANGE	Below 960MHz
MODULATION TECHNOLOGY	MOFDM	DETECTOR FUNCTION	Quasi-Peak
ENVIRONMENTAL CONDITIONS	25 deg. C, 65 %RH, 988hPa	INPUT POWER (SYSTEM)	120Vac, 60 Hz
TESTED BY	Dean Wang	TEST MODE	C

ANTENNA POLARITY & TEST DISTANCE: HORIZONTAL AT 3 M								
NO.	FREQ. (MHz)	EMISSION LEVEL (dBuV/m)	LIMIT (dBuV/m)	MARGIN (dB)	ANTENNA HEIGHT (m)	TABLE ANGLE (Degree)	RAW VALUE (dBuV)	CORRECTION FACTOR (dB/m)
1	166.05	36.68 QP	43.50	-6.82	1.50 H	190	22.73	13.95
2	196.60	42.40 QP	43.50	-1.10	1.07 H	212	31.75	10.65
3	238.74	42.00 QP	46.00	-4.00	1.25 H	349	28.92	13.07
4	426.97	39.79 QP	46.00	-6.21	2.00 H	247	21.07	18.72
5	799.72	42.84 QP	46.00	-3.16	1.00 H	316	16.82	26.02
6	812.77	39.21 QP	46.00	-6.79	1.00 H	316	12.96	26.25

ANTENNA POLARITY & TEST DISTANCE: VERTICAL AT 3 M								
NO.	FREQ. (MHz)	EMISSION LEVEL (dBuV/m)	LIMIT (dBuV/m)	MARGIN (dB)	ANTENNA HEIGHT (m)	TABLE ANGLE (Degree)	RAW VALUE (dBuV)	CORRECTION FACTOR (dB/m)
1	33.73	30.76 QP	40.00	-9.24	1.00 V	268	17.00	13.76
2	195.87	36.32 QP	43.50	-7.18	2.00 V	163	25.63	10.69
3	365.47	35.82 QP	46.00	-10.18	1.50 V	178	19.22	16.60
4	426.97	40.14 QP	46.00	-5.86	1.00 V	172	21.42	18.72
5	499.66	36.84 QP	46.00	-9.16	1.00 V	307	16.42	20.42
6	801.58	42.96 QP	46.00	-3.04	1.25 V	244	16.91	26.05
7	812.77	38.37 QP	46.00	-7.63	1.25 V	247	12.11	26.25

- REMARKS:**
1. Emission level (dBuV/m) = Raw Value (dBuV) + Correction Factor (dB/m).
 2. Correction Factor (dB/m) = Antenna Factor (dB/m) + Cable Factor (dB).
 3. The other emission levels were very low against the limit.
 4. Margin value = Emission level – Limit value.



A D T

EUT TEST CONDITION		MEASUREMENT DETAIL	
SUB-BAND	1 + 2 + 3	FREQUENCY RANGE	Below 960MHz
MODULATION TECHNOLOGY	MOFDM	DETECTOR FUNCTION	Quasi-Peak
ENVIRONMENTAL CONDITIONS	25 deg. C, 65 %RH, 988hPa	INPUT POWER (SYSTEM)	120Vac, 60 Hz
TESTED BY	Dean Wang	TEST MODE	D

ANTENNA POLARITY & TEST DISTANCE: HORIZONTAL AT 3 M								
NO.	FREQ. (MHz)	EMISSION LEVEL (dBuV/m)	LIMIT (dBuV/m)	MARGIN (dB)	ANTENNA HEIGHT (m)	TABLE ANGLE (Degree)	RAW VALUE (dBuV)	CORRECTION FACTOR (dB/m)
1	166.05	37.08 QP	43.50	-6.42	2.50 H	178	23.14	13.95
2	195.87	42.37 QP	43.50	-1.13	2.00 H	211	31.68	10.69
3	238.74	41.50 QP	46.00	-4.50	1.00 H	328	28.43	13.07
4	426.97	39.37 QP	46.00	-6.63	2.00 H	235	20.65	18.72
5	479.16	37.40 QP	46.00	-8.60	1.50 H	208	17.44	19.96
6	801.58	41.26 QP	46.00	-4.74	1.50 H	238	15.22	26.05
7	812.77	35.47 QP	46.00	-10.53	2.00 H	319	9.22	26.25
ANTENNA POLARITY & TEST DISTANCE: VERTICAL AT 3 M								
NO.	FREQ. (MHz)	EMISSION LEVEL (dBuV/m)	LIMIT (dBuV/m)	MARGIN (dB)	ANTENNA HEIGHT (m)	TABLE ANGLE (Degree)	RAW VALUE (dBuV)	CORRECTION FACTOR (dB/m)
1	166.05	32.66 QP	43.50	-10.84	2.00 V	244	18.71	13.95
2	195.87	36.64 QP	43.50	-6.86	2.00 V	154	25.95	10.69
3	365.47	35.79 QP	46.00	-10.21	1.50 V	172	19.19	16.60
4	426.97	40.79 QP	46.00	-5.21	1.25 V	175	22.07	18.72
5	499.66	36.59 QP	46.00	-9.41	1.00 V	301	16.17	20.42
6	801.58	42.62 QP	46.00	-3.38	1.25 V	235	16.57	26.05
7	812.77	38.83 QP	46.00	-7.17	1.25 V	235	12.58	26.25

- REMARKS:**
1. Emission level (dBuV/m) = Raw Value (dBuV) + Correction Factor (dB/m).
 2. Correction Factor (dB/m) = Antenna Factor (dB/m) + Cable Factor (dB).
 3. The other emission levels were very low against the limit.
 4. Margin value = Emission level – Limit value.



A D T

EUT TEST CONDITION		MEASUREMENT DETAIL	
SUB-BAND	1 + 2 + 3	FREQUENCY RANGE	Below 960MHz
MODULATION TECHNOLOGY	MOFDM	DETECTOR FUNCTION	Quasi-Peak
ENVIRONMENTAL CONDITIONS	25 deg. C, 65 %RH, 988hPa	INPUT POWER (SYSTEM)	120Vac, 60 Hz
TESTED BY	Dean Wang	TEST MODE	E

ANTENNA POLARITY & TEST DISTANCE: HORIZONTAL AT 3 M								
NO.	FREQ. (MHz)	EMISSION LEVEL (dBuV/m)	LIMIT (dBuV/m)	MARGIN (dB)	ANTENNA HEIGHT (m)	TABLE ANGLE (Degree)	RAW VALUE (dBuV)	CORRECTION FACTOR (dB/m)
1	98.96	39.08 QP	43.50	-4.42	2.50 H	226	27.87	11.22
2	166.05	34.87 QP	43.50	-8.63	2.50 H	91	20.92	13.95
3	426.97	41.31 QP	46.00	-4.69	2.00 H	235	22.58	18.72
4	479.16	36.07 QP	46.00	-9.93	1.50 H	181	16.11	19.96
5	801.58	42.37 QP	46.00	-3.63	1.00 H	154	16.32	26.05
6	812.77	35.49 QP	46.00	-10.51	1.00 H	154	9.24	26.25
ANTENNA POLARITY & TEST DISTANCE: VERTICAL AT 3 M								
NO.	FREQ. (MHz)	EMISSION LEVEL (dBuV/m)	LIMIT (dBuV/m)	MARGIN (dB)	ANTENNA HEIGHT (m)	TABLE ANGLE (Degree)	RAW VALUE (dBuV)	CORRECTION FACTOR (dB/m)
1	98.96	33.92 QP	43.50	-9.58	1.00 V	205	22.71	11.22
2	166.05	31.71 QP	43.50	-11.79	1.00 V	250	17.76	13.95
3	365.47	35.43 QP	46.00	-10.57	1.50 V	157	18.84	16.60
4	426.97	40.47 QP	46.00	-5.53	1.25 V	205	21.74	18.72
5	499.66	38.00 QP	46.00	-8.00	1.00 V	304	17.58	20.42
6	801.58	36.80 QP	46.00	-9.20	1.25 V	145	10.75	26.05
7	812.77	34.76 QP	46.00	-11.24	1.00 V	259	8.51	26.25

- REMARKS:**
1. Emission level (dBuV/m) = Raw Value (dBuV) + Correction Factor (dB/m).
 2. Correction Factor (dB/m) = Antenna Factor (dB/m) + Cable Factor (dB).
 3. The other emission levels were very low against the limit.
 4. Margin value = Emission level – Limit value.



A D T

EUT TEST CONDITION		MEASUREMENT DETAIL	
SUB-BAND	1 + 2 + 3	FREQUENCY RANGE	Below 960MHz
MODULATION TECHNOLOGY	MOFDM	DETECTOR FUNCTION	Quasi-Peak
ENVIRONMENTAL CONDITIONS	25 deg. C, 65 %RH, 988hPa	INPUT POWER (SYSTEM)	120Vac, 60 Hz
TESTED BY	Dean Wang	TEST MODE	F

ANTENNA POLARITY & TEST DISTANCE: HORIZONTAL AT 3 M								
NO.	FREQ. (MHz)	EMISSION LEVEL (dBuV/m)	LIMIT (dBuV/m)	MARGIN (dB)	ANTENNA HEIGHT (m)	TABLE ANGLE (Degree)	RAW VALUE (dBuV)	CORRECTION FACTOR (dB/m)
1	98.96	37.55 QP	43.50	-5.95	2.50 H	229	26.33	11.22
2	166.05	33.72 QP	43.50	-9.78	2.50 H	73	19.77	13.95
3	426.97	41.42 QP	46.00	-4.58	2.00 H	247	22.69	18.72
4	499.66	34.17 QP	46.00	-11.83	1.50 H	223	13.75	20.42
5	801.58	39.87 QP	46.00	-6.13	1.00 H	136	13.82	26.05
6	812.77	34.16 QP	46.00	-11.84	2.50 H	247	7.91	26.25
ANTENNA POLARITY & TEST DISTANCE: VERTICAL AT 3 M								
NO.	FREQ. (MHz)	EMISSION LEVEL (dBuV/m)	LIMIT (dBuV/m)	MARGIN (dB)	ANTENNA HEIGHT (m)	TABLE ANGLE (Degree)	RAW VALUE (dBuV)	CORRECTION FACTOR (dB/m)
1	98.96	33.07 QP	43.50	-10.43	1.00 V	190	21.85	11.22
2	166.05	31.43 QP	43.50	-12.07	1.00 V	241	17.49	13.95
3	365.47	34.57 QP	46.00	-11.43	1.50 V	160	17.98	16.60
4	426.97	40.00 QP	46.00	-6.00	1.50 V	223	21.27	18.72
5	499.66	36.85 QP	46.00	-9.15	1.00 V	304	16.44	20.42
6	713.99	33.70 QP	46.00	-12.30	1.25 V	286	8.54	25.16
7	801.58	37.19 QP	46.00	-8.81	1.50 V	109	11.14	26.05

- REMARKS:**
1. Emission level (dBuV/m) = Raw Value (dBuV) + Correction Factor (dB/m).
 2. Correction Factor (dB/m) = Antenna Factor (dB/m) + Cable Factor (dB).
 3. The other emission levels were very low against the limit.
 4. Margin value = Emission level – Limit value.



A D T

EUT TEST CONDITION		MEASUREMENT DETAIL	
SUB-BAND	1 + 2 + 3	FREQUENCY RANGE	Below 960MHz
MODULATION TECHNOLOGY	MOFDM	DETECTOR FUNCTION	Quasi-Peak
ENVIRONMENTAL CONDITIONS	25 deg. C, 65 %RH, 988hPa	INPUT POWER (SYSTEM)	120Vac, 60 Hz
TESTED BY	Dean Wang	TEST MODE	G

ANTENNA POLARITY & TEST DISTANCE: HORIZONTAL AT 3 M								
NO.	FREQ. (MHz)	EMISSION LEVEL (dBuV/m)	LIMIT (dBuV/m)	MARGIN (dB)	ANTENNA HEIGHT (m)	TABLE ANGLE (Degree)	RAW VALUE (dBuV)	CORRECTION FACTOR (dB/m)
1	166.00	36.32 QP	43.50	-7.18	2.50 H	199	22.37	13.95
2	196.61	42.37 QP	43.50	-1.13	1.65 H	13	31.72	10.65
3	239.88	41.15 QP	46.00	-4.85	1.00 H	337	28.00	13.15
4	428.48	39.97 QP	46.00	-6.03	2.00 H	241	21.21	18.76
5	479.03	36.84 QP	46.00	-9.16	2.00 H	193	16.89	19.96
6	498.47	34.85 QP	46.00	-11.15	1.50 H	223	14.46	20.39
7	799.84	35.97 QP	46.00	-10.03	2.00 H	346	9.96	26.02
ANTENNA POLARITY & TEST DISTANCE: VERTICAL AT 3 M								
NO.	FREQ. (MHz)	EMISSION LEVEL (dBuV/m)	LIMIT (dBuV/m)	MARGIN (dB)	ANTENNA HEIGHT (m)	TABLE ANGLE (Degree)	RAW VALUE (dBuV)	CORRECTION FACTOR (dB/m)
1	166.05	31.70 QP	43.50	-11.80	2.00 V	244	17.75	13.95
2	195.87	35.65 QP	43.50	-7.85	2.00 V	154	24.95	10.69
3	365.47	35.62 QP	46.00	-10.38	1.25 V	181	19.03	16.60
4	426.97	40.49 QP	46.00	-5.51	1.25 V	178	21.77	18.72
5	499.66	36.77 QP	46.00	-9.23	1.00 V	289	16.35	20.42
6	713.99	34.17 QP	46.00	-11.83	1.25 V	286	9.01	25.16
7	801.58	42.31 QP	46.00	-3.69	1.25 V	253	16.26	26.05
8	812.77	35.12 QP	46.00	-10.88	1.25 V	253	8.87	26.25

- REMARKS:**
1. Emission level (dBuV/m) = Raw Value (dBuV) + Correction Factor (dB/m).
 2. Correction Factor (dB/m) = Antenna Factor (dB/m) + Cable Factor (dB).
 3. The other emission levels were very low against the limit.
 4. Margin value = Emission level – Limit value.



A D T

EUT TEST CONDITION		MEASUREMENT DETAIL	
SUB-BAND	1 + 2 + 3	FREQUENCY RANGE	Below 960MHz
MODULATION TECHNOLOGY	MOFDM	DETECTOR FUNCTION	Quasi-Peak
ENVIRONMENTAL CONDITIONS	25 deg. C, 65 %RH, 988hPa	INPUT POWER (SYSTEM)	120Vac, 60 Hz
TESTED BY	Dean Wang	TEST MODE	H

ANTENNA POLARITY & TEST DISTANCE: HORIZONTAL AT 3 M								
NO.	FREQ. (MHz)	EMISSION LEVEL (dBuV/m)	LIMIT (dBuV/m)	MARGIN (dB)	ANTENNA HEIGHT (m)	TABLE ANGLE (Degree)	RAW VALUE (dBuV)	CORRECTION FACTOR (dB/m)
1	166.05	36.22 QP	43.50	-7.28	2.50 H	184	22.28	13.95
2	195.87	42.38 QP	43.50	-1.12	2.00 H	4	31.69	10.69
3	238.74	40.51 QP	46.00	-5.49	1.00 H	334	27.44	13.07
4	285.33	36.22 QP	46.00	-9.78	1.00 H	88	22.47	13.75
5	426.97	39.49 QP	46.00	-6.51	2.00 H	241	20.76	18.72
6	479.16	35.86 QP	46.00	-10.14	2.00 H	208	15.90	19.96
7	807.17	41.38 QP	46.00	-4.62	1.50 H	235	15.23	26.15
8	812.77	39.74 QP	46.00	-6.26	1.50 H	235	13.48	26.25
ANTENNA POLARITY & TEST DISTANCE: VERTICAL AT 3 M								
NO.	FREQ. (MHz)	EMISSION LEVEL (dBuV/m)	LIMIT (dBuV/m)	MARGIN (dB)	ANTENNA HEIGHT (m)	TABLE ANGLE (Degree)	RAW VALUE (dBuV)	CORRECTION FACTOR (dB/m)
1	166.05	31.91 QP	43.50	-11.59	2.00 V	241	17.97	13.95
2	195.87	35.74 QP	43.50	-7.76	2.00 V	160	25.05	10.69
3	365.47	35.13 QP	46.00	-10.87	1.50 V	175	18.53	16.60
4	426.97	39.50 QP	46.00	-6.50	1.00 V	202	20.78	18.72
5	499.66	36.34 QP	46.00	-9.66	1.00 V	304	15.93	20.42
6	713.99	34.87 QP	46.00	-11.13	1.25 V	265	9.71	25.16
7	801.58	40.91 QP	46.00	-5.09	1.25 V	229	14.86	26.05

- REMARKS:**
1. Emission level (dBuV/m) = Raw Value (dBuV) + Correction Factor (dB/m).
 2. Correction Factor (dB/m) = Antenna Factor (dB/m) + Cable Factor (dB).
 3. The other emission levels were very low against the limit.
 4. Margin value = Emission level – Limit value.



A D T

RADIATED ABOVE 960MHz DATA

EUT TEST CONDITION		MEASUREMENT DETAIL	
SUB-BAND	1 + 2 + 3	FREQUENCY RANGE	960MHz ~ 40GHz
MODULATION TECHNOLOGY	MOFDM	DETECTOR FUNCTION	RMS
INPUT POWER (SYSTEM)	120Vac, 60 Hz	ENVIRONMENTAL CONDITIONS	25 deg. C, 65 %RH, 982hPa
TESTED BY	Dean Wang	TEST MODE	A

ANTENNA POLARITY & TEST DISTANCE: HORIZONTAL AT 1 M								
NO.	FREQ. (MHz)	EMISSION LEVEL (dBuV/m)	LIMIT (dBuV/m)	MARGIN (dB)	ANTENNA HEIGHT (m)	TABLE ANGLE (Degree)	RAW VALUE (dBuV)	CORRECTION FACTOR (dB/m)
1	3236.00	58.18	63.44	-5.26	1.09 H	207	22.95	35.23
2	3984.00	56.35	63.44	-7.09	1.09 H	207	19.30	37.05
3	4476.00	59.16	63.44	-4.28	1.09 H	207	20.42	38.74
4	6472.00	49.37	63.44	-14.07	1.00 H	296	6.16	43.21
5	7968.00	50.41	63.44	-13.03	1.00 H	287	3.75	46.66
6	8952.00	51.17	63.44	-12.27	1.00 H	289	3.69	47.48
ANTENNA POLARITY & TEST DISTANCE: VERTICAL AT 1 M								
NO.	FREQ. (MHz)	EMISSION LEVEL (dBuV/m)	LIMIT (dBuV/m)	MARGIN (dB)	ANTENNA HEIGHT (m)	TABLE ANGLE (Degree)	RAW VALUE (dBuV)	CORRECTION FACTOR (dB/m)
1	3580.00	61.01	63.44	-2.43	1.07 V	258	25.12	35.89
2	4108.00	62.13	63.44	-1.31	1.07 V	258	24.44	37.69
3	4452.00	61.36	63.44	-2.08	1.07 V	258	22.72	38.64
4	7160.00	49.93	63.44	-13.51	1.00 V	125	4.45	45.48
5	8216.00	50.79	63.44	-12.65	1.00 V	146	3.97	46.82
6	8904.00	51.65	63.44	-11.79	1.00 V	138	4.26	47.39

- REMARKS:**
1. Emission level(dBuV/m)=Raw Value(dBuV) + Correction Factor(dB/m)
 2. Correction Factor(dB/m) = Antenna Factor (dB/m) + Cable Factor (dB)
 3. The other emission levels were very low against the limit.
 4. Margin value = Emission level – Limit value.



A D T

EUT TEST CONDITION		MEASUREMENT DETAIL	
SUB-BAND	1 + 2 + 3	FREQUENCY RANGE	960MHz ~ 40GHz
MODULATION TECHNOLOGY	MOFDM	DETECTOR FUNCTION	RMS
INPUT POWER (SYSTEM)	120Vac, 60 Hz	ENVIRONMENTAL CONDITIONS	25 deg. C, 65 %RH, 982hPa
TESTED BY	Dean Wang	TEST MODE	B

ANTENNA POLARITY & TEST DISTANCE: HORIZONTAL AT 1 M								
NO.	FREQ. (MHz)	EMISSION LEVEL (dBuV/m)	LIMIT (dBuV/m)	MARGIN (dB)	ANTENNA HEIGHT (m)	TABLE ANGLE (Degree)	RAW VALUE (dBuV)	CORRECTION FACTOR (dB/m)
1	6392.00	55.52	63.44	-7.92	1.09 H	158	12.61	42.91
2	7008.00	54.50	63.44	-8.94	1.09 H	158	9.19	45.31
3	7852.00	53.28	63.44	-10.16	1.09 H	158	6.76	46.52
4	12784.00	40.18	43.44	-3.26	1.00 H	164	-10.12	50.30
5	14016.00	40.31	43.44	-3.13	1.00 H	171	-12.63	52.94
6	15704.00	40.38	43.44	-3.06	1.00 H	168	-9.25	49.63
ANTENNA POLARITY & TEST DISTANCE: VERTICAL AT 1 M								
NO.	FREQ. (MHz)	EMISSION LEVEL (dBuV/m)	LIMIT (dBuV/m)	MARGIN (dB)	ANTENNA HEIGHT (m)	TABLE ANGLE (Degree)	RAW VALUE (dBuV)	CORRECTION FACTOR (dB/m)
1	6396.00	62.31	63.44	-1.13	1.00 V	124	19.38	42.93
2	6952.00	59.46	63.44	-3.98	1.00 V	124	14.32	45.14
3	7848.00	57.79	63.44	-5.65	1.00 V	124	11.28	46.51
4	12792.00	41.62	43.44	-1.82	1.00 V	133	-8.69	50.31
5	13904.00	40.78	43.44	-2.66	1.00 V	136	-12.03	52.81
6	15696.00	40.81	43.44	-2.63	1.00 V	129	-8.82	49.63

- REMARKS:**
1. Emission level(dBuV/m)=Raw Value(dBuV) + Correction Factor(dB/m)
 2. Correction Factor(dB/m) = Antenna Factor (dB/m) + Cable Factor (dB)
 3. The other emission levels were very low against the limit.
 4. Margin value = Emission level – Limit value.



A D T

EUT TEST CONDITION		MEASUREMENT DETAIL	
SUB-BAND	1 + 2 + 3	FREQUENCY RANGE	960MHz ~ 40GHz
MODULATION TECHNOLOGY	MOFDM	DETECTOR FUNCTION	RMS
INPUT POWER (SYSTEM)	120Vac, 60 Hz	ENVIRONMENTAL CONDITIONS	25 deg. C, 65 %RH, 982hPa
TESTED BY	Dean Wang	TEST MODE	C

ANTENNA POLARITY & TEST DISTANCE: HORIZONTAL AT 1 M								
NO.	FREQ. (MHz)	EMISSION LEVEL (dBuV/m)	LIMIT (dBuV/m)	MARGIN (dB)	ANTENNA HEIGHT (m)	TABLE ANGLE (Degree)	RAW VALUE (dBuV)	CORRECTION FACTOR (dB/m)
1	3316.00	52.49	63.44	-10.95	1.09 H	58	17.15	35.34
2	4108.00	54.31	63.44	-9.13	1.09 H	58	16.62	37.69
3	4368.00	54.07	63.44	-9.37	1.09 H	58	15.76	38.31
4	6632.00	49.98	63.44	-13.46	1.00 H	275	6.04	43.94
5	8216.00	50.74	63.44	-12.70	1.00 H	279	3.92	46.82
6	8736.00	51.69	63.44	-11.75	1.00 H	282	4.46	47.23
ANTENNA POLARITY & TEST DISTANCE: VERTICAL AT 1 M								
NO.	FREQ. (MHz)	EMISSION LEVEL (dBuV/m)	LIMIT (dBuV/m)	MARGIN (dB)	ANTENNA HEIGHT (m)	TABLE ANGLE (Degree)	RAW VALUE (dBuV)	CORRECTION FACTOR (dB/m)
1	3308.00	62.36	63.44	-1.08	1.00 V	1	27.02	35.34
2	4108.00	62.13	63.44	-1.31	1.00 V	1	24.44	37.69
3	4436.00	62.25	63.44	-1.19	1.00 V	1	23.68	38.57
4	6616.00	50.27	63.44	-13.17	1.00 V	133	6.38	43.89
5	8216.00	50.95	63.44	-12.49	1.00 V	141	4.13	46.82
6	8872.00	52.03	63.44	-11.41	1.00 V	154	4.69	47.34

- REMARKS:**
1. Emission level(dBuV/m)=Raw Value(dBuV) + Correction Factor(dB/m)
 2. Correction Factor(dB/m) = Antenna Factor (dB/m) + Cable Factor (dB)
 3. The other emission levels were very low against the limit.
 4. Margin value = Emission level – Limit value.



A D T

EUT TEST CONDITION		MEASUREMENT DETAIL	
SUB-BAND	1 + 2 + 3	FREQUENCY RANGE	960MHz ~ 40GHz
MODULATION TECHNOLOGY	MOFDM	DETECTOR FUNCTION	RMS
INPUT POWER (SYSTEM)	120Vac, 60 Hz	ENVIRONMENTAL CONDITIONS	25 deg. C, 65 %RH, 982hPa
TESTED BY	Dean Wang	TEST MODE	D

ANTENNA POLARITY & TEST DISTANCE: HORIZONTAL AT 1 M								
NO.	FREQ. (MHz)	EMISSION LEVEL (dBuV/m)	LIMIT (dBuV/m)	MARGIN (dB)	ANTENNA HEIGHT (m)	TABLE ANGLE (Degree)	RAW VALUE (dBuV)	CORRECTION FACTOR (dB/m)
1	6536.00	54.56	63.44	-8.88	1.14 H	304	11.06	43.50
2	7004.00	54.75	63.44	-8.69	1.14 H	304	9.45	45.30
3	7612.00	51.60	63.44	-11.84	1.14 H	304	5.15	46.45
4	13072.00	40.24	43.44	-3.20	1.00 H	295	-10.58	50.82
5	14008.00	40.23	43.44	-3.21	1.00 H	301	-12.69	52.92
6	15224.00	40.29	43.44	-3.15	1.00 H	299	-11.04	51.33

ANTENNA POLARITY & TEST DISTANCE: VERTICAL AT 1 M								
NO.	FREQ. (MHz)	EMISSION LEVEL (dBuV/m)	LIMIT (dBuV/m)	MARGIN (dB)	ANTENNA HEIGHT (m)	TABLE ANGLE (Degree)	RAW VALUE (dBuV)	CORRECTION FACTOR (dB/m)
1	6528.00	60.99	63.44	-2.45	1.00 V	1	17.53	43.46
2	6920.00	59.45	63.44	-3.99	1.00 V	1	14.41	45.04
3	7604.00	56.58	63.44	-6.86	1.00 V	1	10.12	46.46
4	13056.00	41.75	43.44	-1.69	1.00 V	5	-9.01	50.76
5	13840.00	40.89	43.44	-2.55	1.00 V	7	-11.72	52.61
6	15696.00	40.93	43.44	-2.51	1.00 V	4	-8.70	49.63

- REMARKS:**
1. Emission level(dBuV/m)=Raw Value(dBuV) + Correction Factor(dB/m)
 2. Correction Factor(dB/m) = Antenna Factor (dB/m) + Cable Factor (dB)
 3. The other emission levels were very low against the limit.
 4. Margin value = Emission level – Limit value.



A D T

EUT TEST CONDITION		MEASUREMENT DETAIL	
SUB-BAND	1 + 2 + 3	FREQUENCY RANGE	960MHz ~ 40GHz
MODULATION TECHNOLOGY	MOFDM	DETECTOR FUNCTION	RMS
INPUT POWER (SYSTEM)	120Vac, 60 Hz	ENVIRONMENTAL CONDITIONS	25 deg. C, 65 %RH, 982hPa
TESTED BY	Dean Wang	TEST MODE	E

ANTENNA POLARITY & TEST DISTANCE: HORIZONTAL AT 1 M								
NO.	FREQ. (MHz)	EMISSION LEVEL (dBuV/m)	LIMIT (dBuV/m)	MARGIN (dB)	ANTENNA HEIGHT (m)	TABLE ANGLE (Degree)	RAW VALUE (dBuV)	CORRECTION FACTOR (dB/m)
1	3532.00	58.34	63.44	-5.10	1.00 H	206	22.57	35.77
2	3824.00	56.57	63.44	-6.87	1.00 H	206	19.95	36.62
3	4584.00	56.04	63.44	-7.40	1.00 H	206	17.10	38.94
4	7064.00	49.41	63.44	-14.03	1.00 H	288	4.04	45.37
5	7648.00	50.53	63.44	-12.91	1.00 H	296	4.09	46.44
6	9168.00	51.24	63.44	-12.20	1.00 H	294	3.38	47.86

ANTENNA POLARITY & TEST DISTANCE: VERTICAL AT 1 M								
NO.	FREQ. (MHz)	EMISSION LEVEL (dBuV/m)	LIMIT (dBuV/m)	MARGIN (dB)	ANTENNA HEIGHT (m)	TABLE ANGLE (Degree)	RAW VALUE (dBuV)	CORRECTION FACTOR (dB/m)
1	3592.00	61.12	63.44	-2.32	1.02 V	247	25.20	35.92
2	4160.00	61.83	63.44	-1.61	1.02 V	247	24.11	37.72
3	4460.00	61.21	63.44	-2.23	1.02 V	247	22.54	38.67
4	7184.00	49.78	63.44	-13.66	1.00 V	235	4.28	45.50
5	8320.00	50.71	63.44	-12.73	1.00 V	239	3.74	46.97
6	8920.00	51.62	63.44	-11.82	1.00 V	243	4.20	47.42

- REMARKS:**
1. Emission level(dBuV/m)=Raw Value(dBuV) + Correction Factor(dB/m)
 2. Correction Factor(dB/m) = Antenna Factor (dB/m) + Cable Factor (dB)
 3. The other emission levels were very low against the limit.
 4. Margin value = Emission level – Limit value.



A D T

EUT TEST CONDITION		MEASUREMENT DETAIL	
SUB-BAND	1 + 2 + 3	FREQUENCY RANGE	960MHz ~ 40GHz
MODULATION TECHNOLOGY	MOFDM	DETECTOR FUNCTION	RMS
INPUT POWER (SYSTEM)	120Vac, 60 Hz	ENVIRONMENTAL CONDITIONS	25 deg. C, 65 %RH, 982hPa
TESTED BY	Dean Wang	TEST MODE	F

ANTENNA POLARITY & TEST DISTANCE: HORIZONTAL AT 1 M								
NO.	FREQ. (MHz)	EMISSION LEVEL (dBuV/m)	LIMIT (dBuV/m)	MARGIN (dB)	ANTENNA HEIGHT (m)	TABLE ANGLE (Degree)	RAW VALUE (dBuV)	CORRECTION FACTOR (dB/m)
1	6384.00	56.13	63.44	-7.31	1.15 H	154	13.25	42.88
2	7008.00	55.59	63.44	-7.85	1.15 H	154	10.28	45.31
3	7856.00	53.37	63.44	-10.07	1.15 H	154	6.85	46.52
4	12768.00	40.09	43.44	-3.35	1.00 H	166	-10.18	50.27
5	14016.00	40.24	43.44	-3.20	1.00 H	161	-12.70	52.94
6	15712.00	40.27	43.44	-3.17	1.00 H	173	-9.35	49.62
ANTENNA POLARITY & TEST DISTANCE: VERTICAL AT 1 M								
NO.	FREQ. (MHz)	EMISSION LEVEL (dBuV/m)	LIMIT (dBuV/m)	MARGIN (dB)	ANTENNA HEIGHT (m)	TABLE ANGLE (Degree)	RAW VALUE (dBuV)	CORRECTION FACTOR (dB/m)
1	6400.00	62.25	63.44	-1.19	1.04 V	119	19.31	42.94
2	7008.00	59.81	63.44	-3.63	1.04 V	119	14.50	45.31
3	7484.00	57.75	63.44	-5.69	1.04 V	119	11.59	46.16
4	12800.00	40.83	43.44	-2.61	1.00 V	132	-9.50	50.33
5	14016.00	40.63	43.44	-2.81	1.00 V	128	-12.31	52.94
6	14968.00	40.68	43.44	-2.76	1.00 V	135	-11.89	52.57

- REMARKS:**
1. Emission level(dBuV/m)=Raw Value(dBuV) + Correction Factor(dB/m)
 2. Correction Factor(dB/m) = Antenna Factor (dB/m) + Cable Factor (dB)
 3. The other emission levels were very low against the limit.
 4. Margin value = Emission level – Limit value.



A D T

EUT TEST CONDITION		MEASUREMENT DETAIL	
SUB-BAND	1 + 2 + 3	FREQUENCY RANGE	960MHz ~ 40GHz
MODULATION TECHNOLOGY	MOFDM	DETECTOR FUNCTION	RMS
INPUT POWER (SYSTEM)	120Vac, 60 Hz	ENVIRONMENTAL CONDITIONS	25 deg. C, 65 %RH, 982hPa
TESTED BY	Dean Wang	TEST MODE	G

ANTENNA POLARITY & TEST DISTANCE: HORIZONTAL AT 1 M								
NO.	FREQ. (MHz)	EMISSION LEVEL (dBuV/m)	LIMIT (dBuV/m)	MARGIN (dB)	ANTENNA HEIGHT (m)	TABLE ANGLE (Degree)	RAW VALUE (dBuV)	CORRECTION FACTOR (dB/m)
1	3392.00	52.45	63.44	-10.99	1.13 H	217	17.04	35.41
2	4104.00	53.98	63.44	-9.46	1.13 H	217	16.30	37.68
3	4512.00	54.59	63.44	-8.85	1.13 H	217	15.73	38.86
4	6784.00	49.68	63.44	-13.76	1.00 H	198	5.22	44.46
5	8208.00	50.45	63.44	-12.99	1.00 H	203	3.65	46.80
6	9024.00	51.12	63.44	-12.32	1.00 H	208	3.51	47.61
ANTENNA POLARITY & TEST DISTANCE: VERTICAL AT 1 M								
NO.	FREQ. (MHz)	EMISSION LEVEL (dBuV/m)	LIMIT (dBuV/m)	MARGIN (dB)	ANTENNA HEIGHT (m)	TABLE ANGLE (Degree)	RAW VALUE (dBuV)	CORRECTION FACTOR (dB/m)
1	3392.00	62.36	63.44	-1.08	1.00 V	334	26.95	35.41
2	4096.00	62.29	63.44	-1.15	1.00 V	334	24.63	37.66
3	4440.00	62.15	63.44	-1.29	1.00 V	334	23.56	38.59
4	6784.00	49.97	63.44	-13.47	1.00 V	315	5.51	44.46
5	8192.00	50.83	63.44	-12.61	1.00 V	321	4.04	46.79
6	8880.00	51.46	63.44	-11.98	1.00 V	319	4.11	47.35

- REMARKS:**
1. Emission level(dBuV/m)=Raw Value(dBuV) + Correction Factor(dB/m)
 2. Correction Factor(dB/m) = Antenna Factor (dB/m) + Cable Factor (dB)
 3. The other emission levels were very low against the limit.
 4. Margin value = Emission level – Limit value.



A D T

EUT TEST CONDITION		MEASUREMENT DETAIL	
SUB-BAND	1 + 2 + 3	FREQUENCY RANGE	960MHz ~ 40GHz
MODULATION TECHNOLOGY	MOFDM	DETECTOR FUNCTION	RMS
INPUT POWER (SYSTEM)	120Vac, 60 Hz	ENVIRONMENTAL CONDITIONS	25 deg. C, 65 %RH, 982hPa
TESTED BY	Dean Wang	TEST MODE	H

ANTENNA POLARITY & TEST DISTANCE: HORIZONTAL AT 1 M								
NO.	FREQ. (MHz)	EMISSION LEVEL (dBuV/m)	LIMIT (dBuV/m)	MARGIN (dB)	ANTENNA HEIGHT (m)	TABLE ANGLE (Degree)	RAW VALUE (dBuV)	CORRECTION FACTOR (dB/m)
1	6556.00	54.39	63.44	-9.05	1.23 H	317	10.79	43.60
2	6936.00	54.57	63.44	-8.87	1.23 H	317	9.48	45.09
3	7640.00	51.91	63.44	-11.53	1.23 H	317	5.47	46.44
4	13112.00	40.15	43.44	-3.29	1.00 H	298	-10.81	50.96
5	13872.00	40.11	43.44	-3.33	1.00 H	302	-12.60	52.71
6	15280.00	40.13	43.44	-3.31	1.00 H	309	-10.92	51.05
ANTENNA POLARITY & TEST DISTANCE: VERTICAL AT 1 M								
NO.	FREQ. (MHz)	EMISSION LEVEL (dBuV/m)	LIMIT (dBuV/m)	MARGIN (dB)	ANTENNA HEIGHT (m)	TABLE ANGLE (Degree)	RAW VALUE (dBuV)	CORRECTION FACTOR (dB/m)
1	6556.00	62.30	63.44	-1.14	1.00 V	255	18.70	43.60
2	7004.00	61.92	63.44	-1.52	1.00 V	255	16.62	45.30
3	7584.00	60.68	63.44	-2.76	1.00 V	255	14.26	46.42
4	13112.00	40.75	43.44	-2.69	1.00 V	235	-10.21	50.96
5	14008.00	40.69	43.44	-2.75	1.00 V	239	-12.23	52.92
6	15168.00	40.59	43.44	-2.85	1.00 V	241	-11.02	51.61

- REMARKS:**
1. Emission level(dBuV/m)=Raw Value(dBuV) + Correction Factor(dB/m)
 2. Correction Factor(dB/m) = Antenna Factor (dB/m) + Cable Factor (dB)
 3. The other emission levels were very low against the limit.
 4. Margin value = Emission level – Limit value.



A D T

EMISSIONS FROM NOTEBOOK**(BAND GROUP 1, WITHOUT METAL SHIELDING CASE)**

EUT TEST CONDITION		MEASUREMENT DETAIL	
SUB-BAND	1 + 2 + 3	FREQUENCY RANGE	Below 1GHz
MODULATION TECHNOLOGY	MOFDM	DETECTOR FUNCTION	Quasi-Peak
INPUT POWER (SYSTEM)	120Vac, 60 Hz	ENVIRONMENTAL CONDITIONS	25 deg. C, 65 %RH, 982hPa
TESTED BY	Dean Wang		

ANTENNA POLARITY & TEST DISTANCE: HORIZONTAL AT 3 M								
NO.	FREQ. (MHz)	EMISSION LEVEL (dBuV/m)	LIMIT (dBuV/m)	MARGIN (dB)	ANTENNA HEIGHT (m)	TABLE ANGLE (Degree)	RAW VALUE (dBuV)	CORRECTION FACTOR (dB/m)
1	997.00	43.62 QP	54.00	-10.38	1.00 H	32	14.85	28.77
ANTENNA POLARITY & TEST DISTANCE: VERTICAL AT 3 M								
NO.	FREQ. (MHz)	EMISSION LEVEL (dBuV/m)	LIMIT (dBuV/m)	MARGIN (dB)	ANTENNA HEIGHT (m)	TABLE ANGLE (Degree)	RAW VALUE (dBuV)	CORRECTION FACTOR (dB/m)
1	997.00	40.46 QP	54.00	-13.54	1.00 V	62	11.69	28.77

- REMARKS:**
1. Emission level(dBuV/m)=Raw Value(dBuV) + Correction Factor(dB/m)
 2. Correction Factor(dB/m) = Antenna Factor (dB/m) + Cable Factor (dB)
 3. The other emission levels were very low against the limit.
 4. Margin value = Emission level – Limit value.



A D T

EUT TEST CONDITION		MEASUREMENT DETAIL	
SUB-BAND	1 + 2 + 3	FREQUENCY RANGE	Above 1GHz
MODULATION TECHNOLOGY	MOFDM	DETECTOR FUNCTION	Peak / Average
INPUT POWER (SYSTEM)	120Vac, 60 Hz	ENVIRONMENTAL CONDITIONS	25 deg. C, 65 %RH, 982hPa
TESTED BY	Dean Wang		

ANTENNA POLARITY & TEST DISTANCE: HORIZONTAL AT 1 M								
NO.	FREQ. (MHz)	EMISSION LEVEL (dBuV/m)	LIMIT (dBuV/m)	MARGIN (dB)	ANTENNA HEIGHT (m)	TABLE ANGLE (Degree)	RAW VALUE (dBuV)	CORRECTION FACTOR (dB/m)
1	1070.00	52.29 PK	83.54	-31.25	1.00 H	271	22.74	29.55
2	1070.00	44.58 AV	63.54	-18.96	1.00 H	271	15.03	29.55
3	1141.00	50.54 PK	83.54	-33.00	1.00 H	266	20.81	29.73
4	1141.00	43.36 AV	63.54	-20.18	1.00 H	266	13.63	29.73
5	1920.00	55.41 PK	83.54	-28.13	1.00 H	304	24.08	31.33
6	1920.00	50.06 AV	63.54	-13.48	1.00 H	304	18.73	31.33
ANTENNA POLARITY & TEST DISTANCE: VERTICAL AT 1 M								
NO.	FREQ. (MHz)	EMISSION LEVEL (dBuV/m)	LIMIT (dBuV/m)	MARGIN (dB)	ANTENNA HEIGHT (m)	TABLE ANGLE (Degree)	RAW VALUE (dBuV)	CORRECTION FACTOR (dB/m)
1	1070.00	46.26 PK	83.54	-37.28	1.00 V	238	16.71	29.55
2	1070.00	38.67 AV	63.54	-24.87	1.00 V	238	9.12	29.55
3	1141.00	45.92 PK	83.54	-37.62	1.00 V	298	16.19	29.73
4	1141.00	38.77 AV	63.54	-24.77	1.00 V	298	9.04	29.73
5	1920.00	51.56 PK	83.54	-31.98	1.00 V	291	20.23	31.33
6	1920.00	46.21 AV	63.54	-17.33	1.00 V	291	14.88	31.33

- REMARKS:**
1. Emission level(dBuV/m)=Raw Value(dBuV) + Correction Factor(dB/m)
 2. Correction Factor(dB/m) = Antenna Factor (dB/m) + Cable Factor (dB)
 3. The other emission levels were very low against the limit.
 4. Margin value = Emission level – Limit value.



A D T

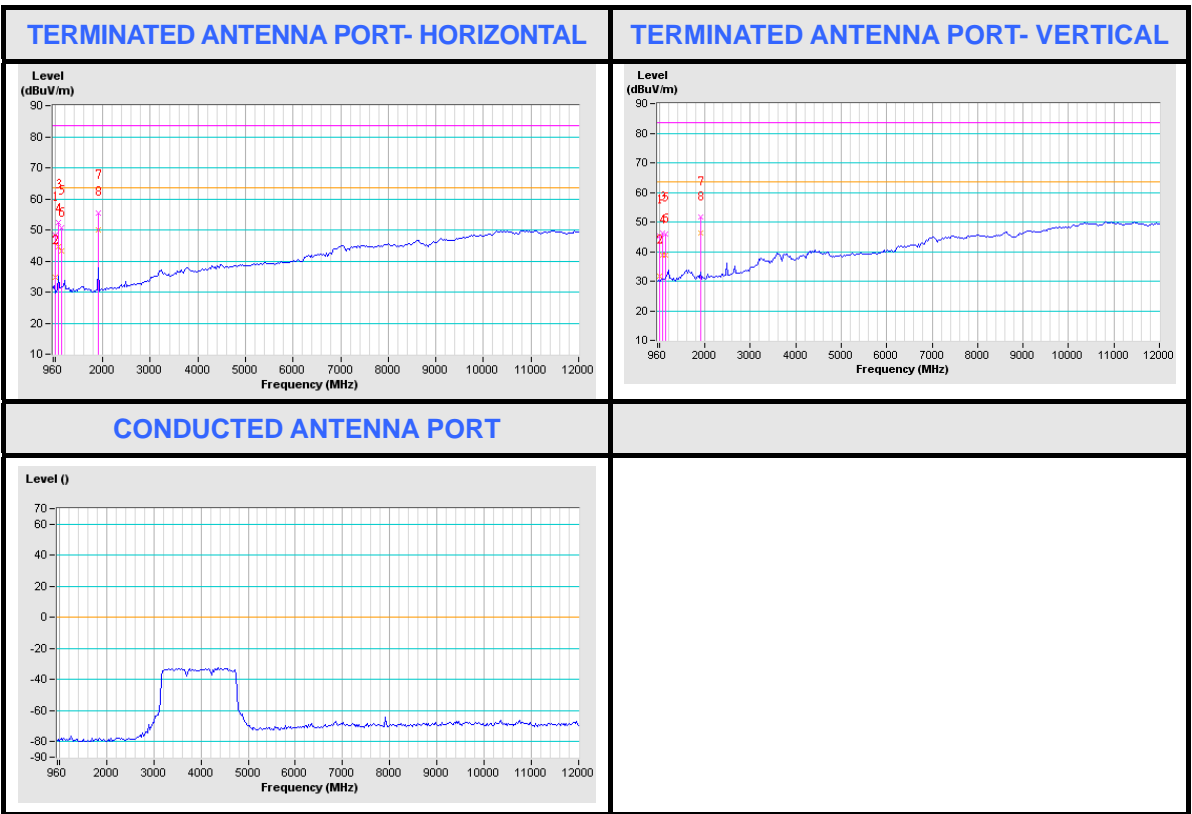



A D T

(BAND GROUP 3, WITHOUT METAL SHIELDING CASE)

EUT TEST CONDITION		MEASUREMENT DETAIL	
SUB-BAND	1 + 2 + 3	FREQUENCY RANGE	Below 1GHz
MODULATION TECHNOLOGY	MOFDM	DETECTOR FUNCTION	Quasi-Peak
INPUT POWER (SYSTEM)	120Vac, 60 Hz	ENVIRONMENTAL CONDITIONS	25 deg. C, 65 %RH, 982hPa
TESTED BY	Dean Wang		

ANTENNA POLARITY & TEST DISTANCE: HORIZONTAL AT 3 M								
NO.	FREQ. (MHz)	EMISSION LEVEL (dBuV/m)	LIMIT (dBuV/m)	MARGIN (dB)	ANTENNA HEIGHT (m)	TABLE ANGLE (Degree)	RAW VALUE (dBuV)	CORRECTION FACTOR (dB/m)
1	997.00	43.64 QP	54.00	-10.36	1.00 H	35	14.87	28.77
ANTENNA POLARITY & TEST DISTANCE: VERTICAL AT 3 M								
NO.	FREQ. (MHz)	EMISSION LEVEL (dBuV/m)	LIMIT (dBuV/m)	MARGIN (dB)	ANTENNA HEIGHT (m)	TABLE ANGLE (Degree)	RAW VALUE (dBuV)	CORRECTION FACTOR (dB/m)
1	997.00	40.35 QP	54.00	-13.65	1.00 V	61	11.58	28.77

- REMARKS:**
1. Emission level(dBuV/m)=Raw Value(dBuV) + Correction Factor(dB/m)
 2. Correction Factor(dB/m) = Antenna Factor (dB/m) + Cable Factor (dB)
 3. The other emission levels were very low against the limit.
 4. Margin value = Emission level – Limit value.



EUT TEST CONDITION		MEASUREMENT DETAIL	
SUB-BAND	1 + 2 + 3	FREQUENCY RANGE	Above 1GHz
MODULATION TECHNOLOGY	MOFDM	DETECTOR FUNCTION	Peak / Average
INPUT POWER (SYSTEM)	120Vac, 60 Hz	ENVIRONMENTAL CONDITIONS	25 deg. C, 65 %RH, 982hPa
TESTED BY	Dean Wang		

ANTENNA POLARITY & TEST DISTANCE: HORIZONTAL AT 1 M								
NO.	FREQ. (MHz)	EMISSION LEVEL (dBuV/m)	LIMIT (dBuV/m)	MARGIN (dB)	ANTENNA HEIGHT (m)	TABLE ANGLE (Degree)	RAW VALUE (dBuV)	CORRECTION FACTOR (dB/m)
1	1070.00	52.18 PK	83.54	-31.36	1.00 H	273	22.63	29.55
2	1070.00	44.49 AV	63.54	-19.05	1.00 H	273	14.94	29.55
3	1141.00	50.46 PK	83.54	-33.08	1.00 H	272	20.73	29.73
4	1141.00	43.28 AV	63.54	-20.26	1.00 H	272	13.55	29.73
5	1920.00	55.34 PK	83.54	-28.20	1.00 H	301	24.01	31.33
6	1920.00	49.98 AV	63.54	-13.56	1.00 H	301	18.65	31.33
ANTENNA POLARITY & TEST DISTANCE: VERTICAL AT 1 M								
NO.	FREQ. (MHz)	EMISSION LEVEL (dBuV/m)	LIMIT (dBuV/m)	MARGIN (dB)	ANTENNA HEIGHT (m)	TABLE ANGLE (Degree)	RAW VALUE (dBuV)	CORRECTION FACTOR (dB/m)
1	1070.00	46.18 PK	83.54	-37.36	1.00 V	241	16.63	29.55
2	1070.00	38.59 AV	63.54	-24.95	1.00 V	241	9.04	29.55
3	1141.00	45.79 PK	83.54	-37.75	1.00 V	301	16.06	29.73
4	1141.00	38.68 AV	63.54	-24.86	1.00 V	301	8.95	29.73
5	1920.00	51.48 PK	83.54	-32.06	1.00 V	293	20.15	31.33
6	1920.00	46.15 AV	63.54	-17.39	1.00 V	293	14.82	31.33

- REMARKS:**
1. Emission level(dBuV/m)=Raw Value(dBuV) + Correction Factor(dB/m)
 2. Correction Factor(dB/m) = Antenna Factor (dB/m) + Cable Factor (dB)
 3. The other emission levels were very low against the limit.
 4. Margin value = Emission level – Limit value.



A D T

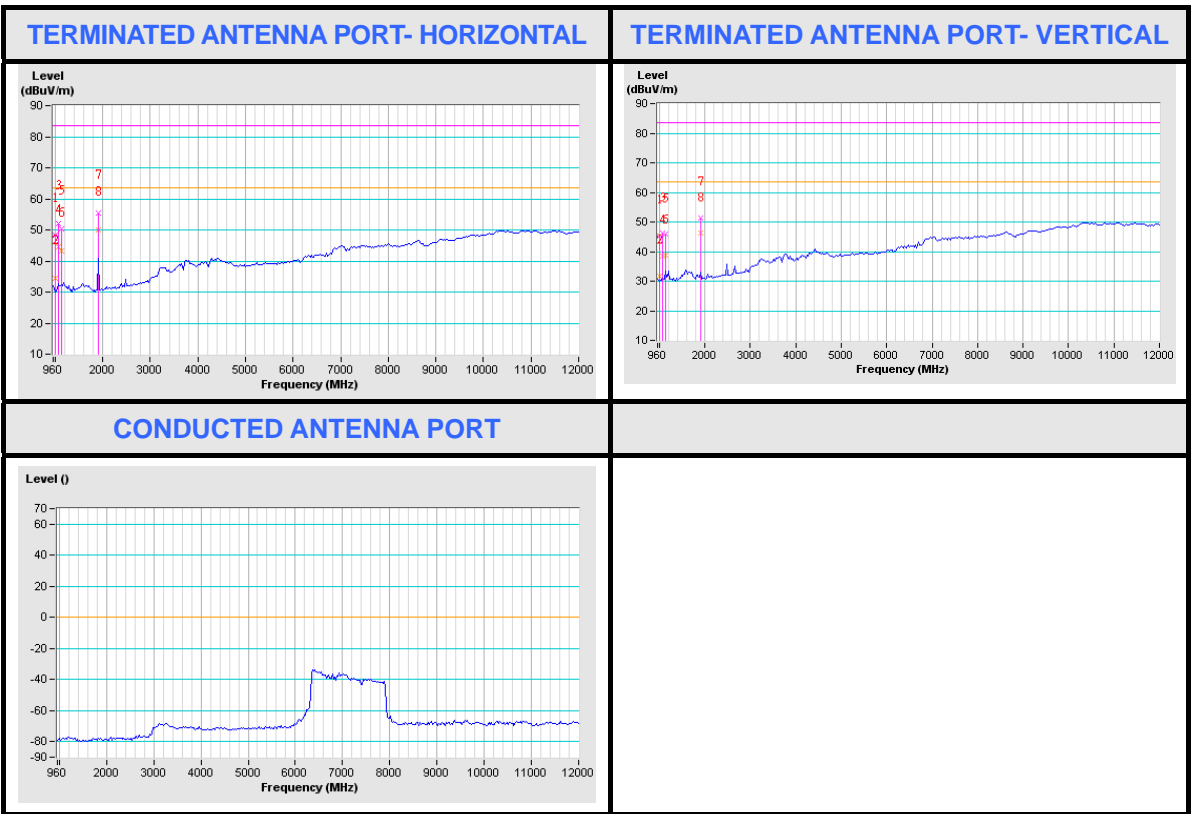



A D T

(BAND GROUP 1, WITH METAL SHIELDING CASE)

EUT TEST CONDITION		MEASUREMENT DETAIL	
SUB-BAND	1 + 2 + 3	FREQUENCY RANGE	Below 1GHz
MODULATION TECHNOLOGY	MOFDM	DETECTOR FUNCTION	Quasi-Peak
INPUT POWER (SYSTEM)	120Vac, 60 Hz	ENVIRONMENTAL CONDITIONS	25 deg. C, 65 %RH, 982hPa
TESTED BY	Dean Wang		

ANTENNA POLARITY & TEST DISTANCE: HORIZONTAL AT 3 M								
NO.	FREQ. (MHz)	EMISSION LEVEL (dBuV/m)	LIMIT (dBuV/m)	MARGIN (dB)	ANTENNA HEIGHT (m)	TABLE ANGLE (Degree)	RAW VALUE (dBuV)	CORRECTION FACTOR (dB/m)
1	997.00	43.49 QP	54.00	-10.51	1.00 H	33	14.72	28.77
ANTENNA POLARITY & TEST DISTANCE: VERTICAL AT 3 M								
NO.	FREQ. (MHz)	EMISSION LEVEL (dBuV/m)	LIMIT (dBuV/m)	MARGIN (dB)	ANTENNA HEIGHT (m)	TABLE ANGLE (Degree)	RAW VALUE (dBuV)	CORRECTION FACTOR (dB/m)
1	997.00	40.51 QP	54.00	-13.49	1.00 V	53	11.74	28.77

- REMARKS:**
1. Emission level(dBuV/m)=Raw Value(dBuV) + Correction Factor(dB/m)
 2. Correction Factor(dB/m) = Antenna Factor (dB/m) + Cable Factor (dB)
 3. The other emission levels were very low against the limit.
 4. Margin value = Emission level – Limit value.



A D T

EUT TEST CONDITION		MEASUREMENT DETAIL	
SUB-BAND	1 + 2 + 3	FREQUENCY RANGE	Above 1GHz
MODULATION TECHNOLOGY	MOFDM	DETECTOR FUNCTION	Peak / Average
INPUT POWER (SYSTEM)	120Vac, 60 Hz	ENVIRONMENTAL CONDITIONS	25 deg. C, 65 %RH, 982hPa
TESTED BY	Dean Wang		

ANTENNA POLARITY & TEST DISTANCE: HORIZONTAL AT 1 M								
NO.	FREQ. (MHz)	EMISSION LEVEL (dBuV/m)	LIMIT (dBuV/m)	MARGIN (dB)	ANTENNA HEIGHT (m)	TABLE ANGLE (Degree)	RAW VALUE (dBuV)	CORRECTION FACTOR (dB/m)
1	1070.00	52.27 PK	83.54	-31.27	1.00 H	276	22.72	29.55
2	1070.00	44.53 AV	63.54	-19.01	1.00 H	276	14.98	29.55
3	1141.00	50.55 PK	83.54	-32.99	1.00 H	270	20.82	29.73
4	1141.00	43.34 AV	63.54	-20.20	1.00 H	270	13.61	29.73
5	1920.00	55.28 PK	83.54	-28.26	1.00 H	303	23.95	31.33
6	1920.00	49.92 AV	63.54	-13.62	1.00 H	303	18.59	31.33
ANTENNA POLARITY & TEST DISTANCE: VERTICAL AT 1 M								
NO.	FREQ. (MHz)	EMISSION LEVEL (dBuV/m)	LIMIT (dBuV/m)	MARGIN (dB)	ANTENNA HEIGHT (m)	TABLE ANGLE (Degree)	RAW VALUE (dBuV)	CORRECTION FACTOR (dB/m)
1	1070.00	46.23 PK	83.54	-37.31	1.00 V	244	16.68	29.55
2	1070.00	38.64 AV	63.54	-24.90	1.00 V	244	9.09	29.55
3	1141.00	45.88 PK	83.54	-37.66	1.00 V	305	16.15	29.73
4	1141.00	38.76 AV	63.54	-24.78	1.00 V	305	9.03	29.73
5	1920.00	51.52 PK	83.54	-32.02	1.00 V	295	20.19	31.33
6	1920.00	46.19 AV	63.54	-17.35	1.00 V	295	14.86	31.33

- REMARKS:**
1. Emission level(dBuV/m)=Raw Value(dBuV) + Correction Factor(dB/m)
 2. Correction Factor(dB/m) = Antenna Factor (dB/m) + Cable Factor (dB)
 3. The other emission levels were very low against the limit.
 4. Margin value = Emission level – Limit value.



A D T

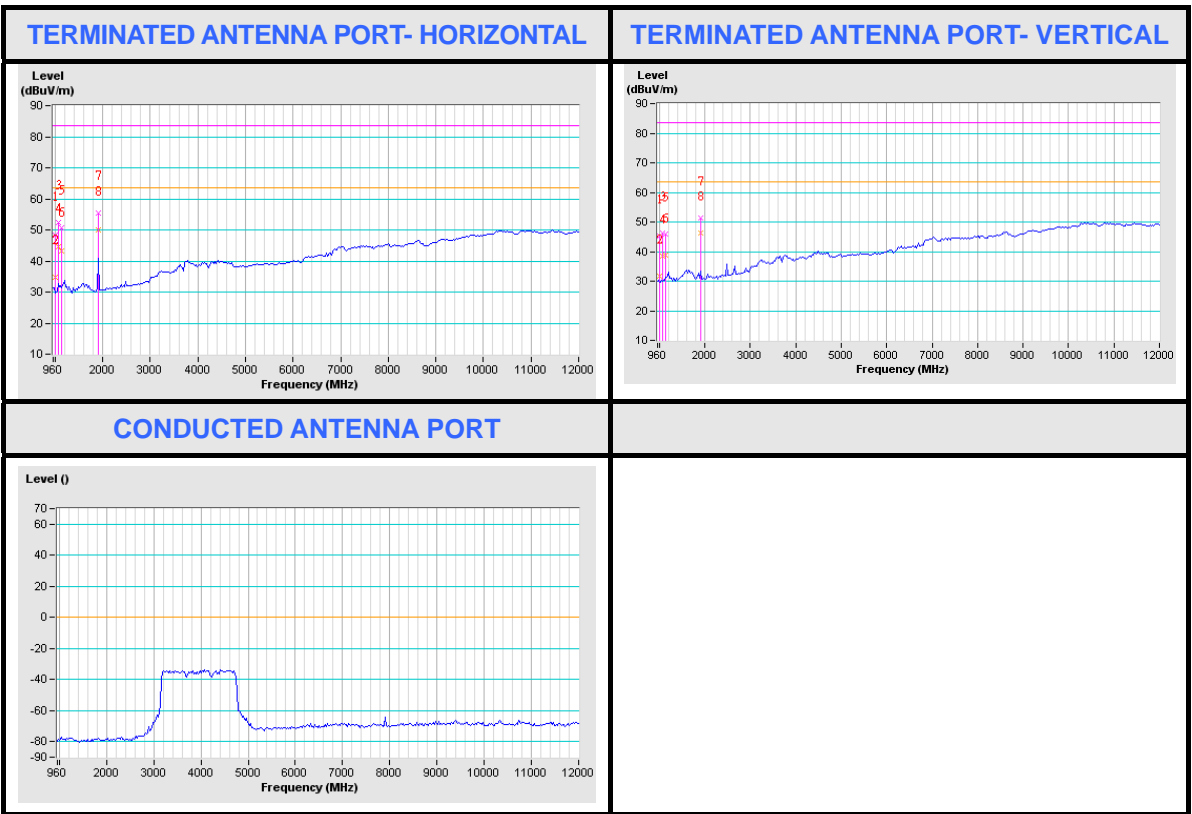



(BAND GROUP 3, WITH METAL SHIELDING CASE)

EUT TEST CONDITION		MEASUREMENT DETAIL	
SUB-BAND	1 + 2 + 3	FREQUENCY RANGE	Below 1GHz
MODULATION TECHNOLOGY	MOFDM	DETECTOR FUNCTION	Quasi-Peak
INPUT POWER (SYSTEM)	120Vac, 60 Hz	ENVIRONMENTAL CONDITIONS	25 deg. C, 65 %RH, 982hPa
TESTED BY	Dean Wang		

ANTENNA POLARITY & TEST DISTANCE: HORIZONTAL AT 3 M								
NO.	FREQ. (MHz)	EMISSION LEVEL (dBuV/m)	LIMIT (dBuV/m)	MARGIN (dB)	ANTENNA HEIGHT (m)	TABLE ANGLE (Degree)	RAW VALUE (dBuV)	CORRECTION FACTOR (dB/m)
1	997.00	43.46 QP	54.00	-10.54	1.00 H	39	14.69	28.77
ANTENNA POLARITY & TEST DISTANCE: VERTICAL AT 3 M								
NO.	FREQ. (MHz)	EMISSION LEVEL (dBuV/m)	LIMIT (dBuV/m)	MARGIN (dB)	ANTENNA HEIGHT (m)	TABLE ANGLE (Degree)	RAW VALUE (dBuV)	CORRECTION FACTOR (dB/m)
1	997.00	40.27 QP	54.00	-13.73	1.00 V	61	11.50	28.77

- REMARKS:**
1. Emission level(dBuV/m)=Raw Value(dBuV) + Correction Factor(dB/m)
 2. Correction Factor(dB/m) = Antenna Factor (dB/m) + Cable Factor (dB)
 3. The other emission levels were very low against the limit.
 4. Margin value = Emission level – Limit value.



A D T

EUT TEST CONDITION		MEASUREMENT DETAIL	
SUB-BAND	1 + 2 + 3	FREQUENCY RANGE	Above 1GHz
MODULATION TECHNOLOGY	MOFDM	DETECTOR FUNCTION	Peak / Average
INPUT POWER (SYSTEM)	120Vac, 60 Hz	ENVIRONMENTAL CONDITIONS	25 deg. C, 65 %RH, 982hPa
TESTED BY	Dean Wang		

ANTENNA POLARITY & TEST DISTANCE: HORIZONTAL AT 1 M								
NO.	FREQ. (MHz)	EMISSION LEVEL (dBuV/m)	LIMIT (dBuV/m)	MARGIN (dB)	ANTENNA HEIGHT (m)	TABLE ANGLE (Degree)	RAW VALUE (dBuV)	CORRECTION FACTOR (dB/m)
1	1070.00	52.14 PK	83.54	-31.40	1.00 H	278	22.59	29.55
2	1070.00	44.40 AV	63.54	-19.14	1.00 H	278	14.85	29.55
3	1141.00	50.39 PK	83.54	-33.15	1.00 H	272	20.66	29.73
4	1141.00	43.20 AV	63.54	-20.34	1.00 H	272	13.47	29.73
5	1920.00	55.16 PK	83.54	-28.38	1.00 H	299	23.83	31.33
6	1920.00	49.81 AV	63.54	-13.73	1.00 H	299	18.48	31.33
ANTENNA POLARITY & TEST DISTANCE: VERTICAL AT 1 M								
NO.	FREQ. (MHz)	EMISSION LEVEL (dBuV/m)	LIMIT (dBuV/m)	MARGIN (dB)	ANTENNA HEIGHT (m)	TABLE ANGLE (Degree)	RAW VALUE (dBuV)	CORRECTION FACTOR (dB/m)
1	1070.00	46.09 PK	83.54	-37.45	1.00 V	242	16.54	29.55
2	1070.00	38.52 AV	63.54	-25.02	1.00 V	242	8.97	29.55
3	1141.00	45.75 PK	83.54	-37.79	1.00 V	308	16.02	29.73
4	1141.00	38.63 AV	63.54	-24.91	1.00 V	308	8.90	29.73
5	1920.00	51.41 PK	83.54	-32.13	1.00 V	298	20.08	31.33
6	1920.00	46.07 AV	63.54	-17.47	1.00 V	298	14.74	31.33

- REMARKS:**
1. Emission level(dBuV/m)=Raw Value(dBuV) + Correction Factor(dB/m)
 2. Correction Factor(dB/m) = Antenna Factor (dB/m) + Cable Factor (dB)
 3. The other emission levels were very low against the limit.
 4. Margin value = Emission level – Limit value.



A D T

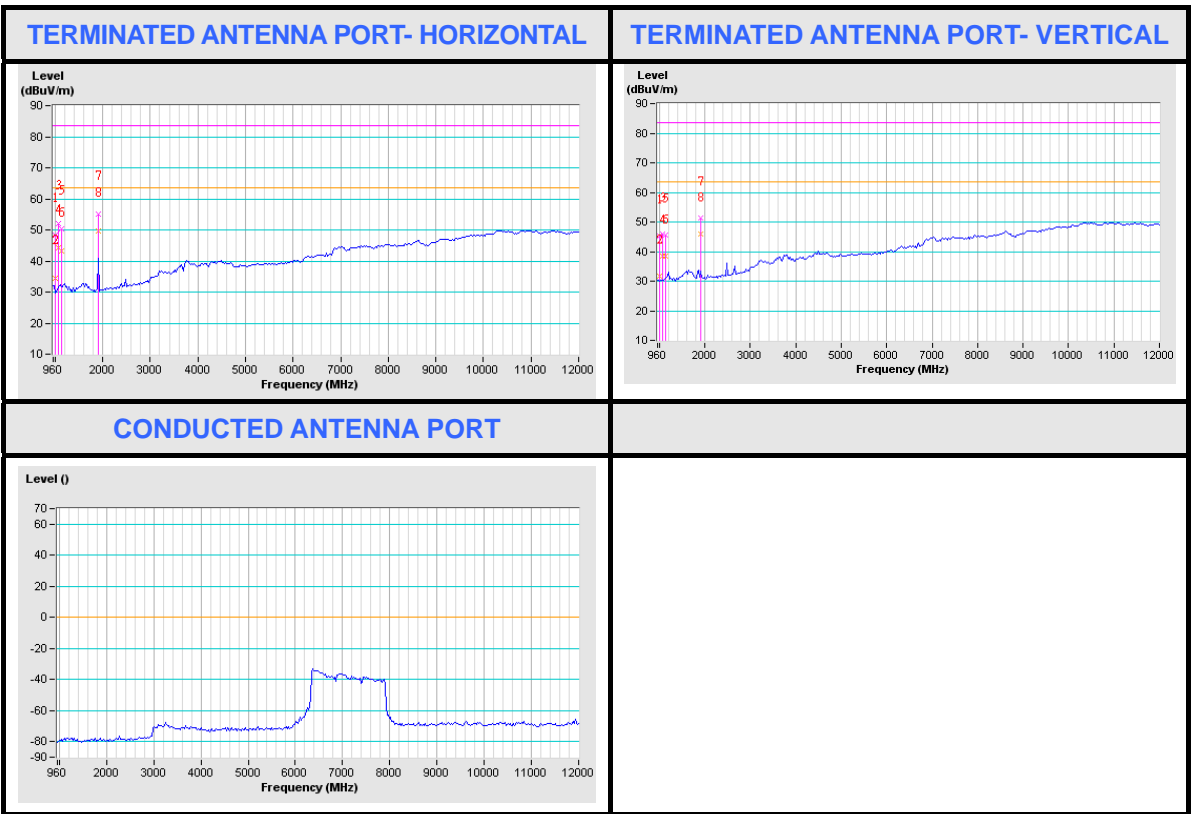

4.3 RADIATED EMISSION MEASUREMENT (FOR 15.519 (d))

4.3.1 LIMITS OF RADIATED EMISSION MEASUREMENT

FREQUENCY IN MHz	EIRP IN dBm	dBuV/m@3m	dBuV/m@1m
1,164 ~ 1,240	-85.3	9.9	19.44
1,559 ~ 1,610	-85.3	9.9	19.44

Transfer rules follow 15.521(g), 15.31(f)(1).

- NOTE:**
- 15.521(g) converted to a peak field strength level at 3 meters using $E(\text{dBuV/m}) = P(\text{dBmEIRP}) + 95.2$.
 - 15.31(f)(1) When performing measurements at a distance other than that specified, the results shall be extrapolated to the specified distance using an extrapolation factor of 20 dB/decade, Measurement distance moves from 3m to 1m, $\text{Limit (1m)} = \text{Limit (3m)} + 20\text{Log (3/1)} = \text{Limit (3m)} + 9.54$.

Instrument Noise Floor

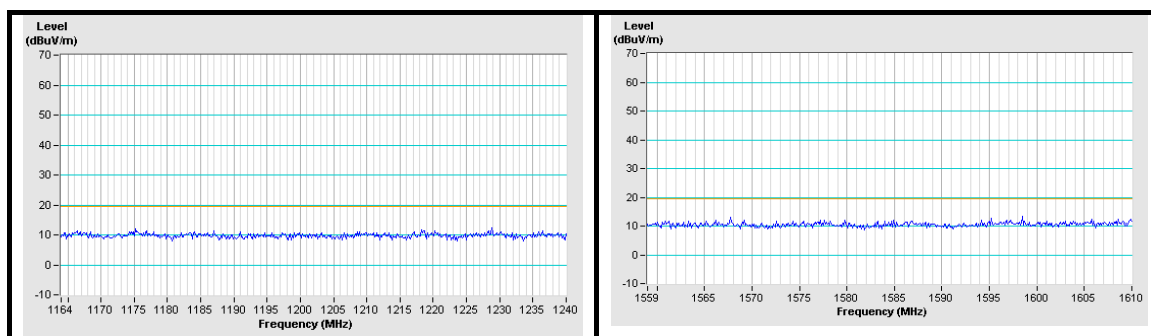

15.521(c) Emissions from digital circuitry used to enable the operation of the UWB transmitter shall comply with the limits in Section 15.209 of this chapter, rather than the limits specified in this subpart.

- NOTE:** Use conducted measurement to determine emissions is from digital circuitry or not. Emissions from digital circuitry follow 15.209 else 15.517

The radiated emissions above 1000MHz from a device operating under the provisions of this section shall not exceed the emission levels in Section 15.209.

FREQUENCY IN MHz	dBuV/m@3m		dBuV/m@1m	
	Peak	Average	Peak	Average
Above 1000	74.00	54.00	83.54	63.54



A D T

4.3.2 INSTRUMENT SETUP VALUE AND MEASUREMENT DISTANCE

UWB transmitters operating under the provisions of this section shall not exceed the following average limits when measured using a resolution bandwidth of no less than 1kHz:

FREQUENCY RANGE	RESOLUTION BANDWIDTH	VIDEO BANDWIDTH	DETECTOR	MEASUREMENT DISTANCE
1,164 ~ 1,240	*10kHz	30kHz	RMS	1 meter
1,559 ~ 1,610	*10kHz	30kHz	RMS	1 meter

NOTE: *reference The Evolution of Modern UWB Technology.

4.3.3 TEST INSTRUMENTS

Same as 4.2.3.



A D T

4.3.4 TEST PROCEDURES

- a. The EUT was placed on the top of a rotating table 0.8 meters above the ground at a 1 meters semi-anechoic chamber. The table was rotated 360 degrees to determine the position of the highest radiation.
- b. The EUT was set 1 meters away from the interference-receiving antenna, which was mounted on the top of a variable-height antenna tower.
- c. The antenna is a broadband antenna, and its height is varied from one meter to four meters above the ground to determine the maximum value of the field strength. Both horizontal and vertical polarizations of the antenna are set to make the measurement.
- d. For each suspected emission, the EUT was arranged to its worst case and then the antenna was tuned to heights from 1 meter to 4 meters and the rotatable table was turned from 0 degrees to 360 degrees to find the maximum reading.

4.3.5 DEVIATION FROM TEST STANDARD

No deviation

4.3.6 TEST SETUP

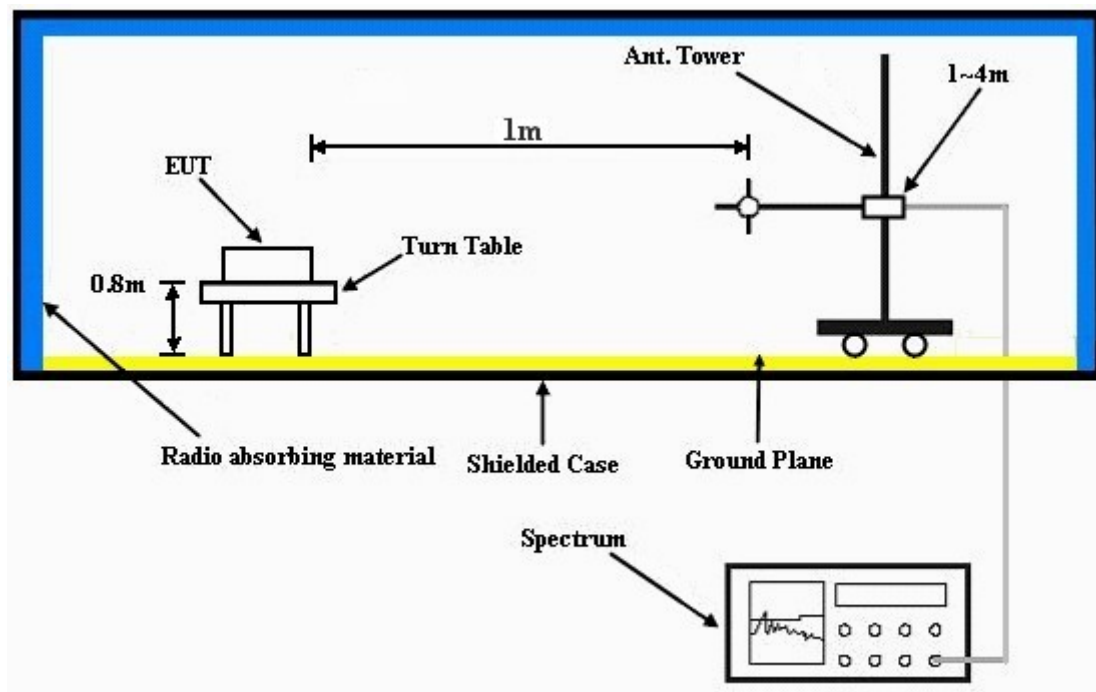

For the actual test configuration, please refer to the attached file (Test Setup Photo).

4.3.7 EUT OPERATING CONDITIONS

Same as 4.1.6



4.3.8 TEST RESULTS

EMISSIONS FROM DIGITAL CIRCUITRY

EUT TEST CONDITION		MEASUREMENT DETAIL	
SUB-BAND	1 + 2 + 3	FREQUENCY RANGE	Above 1GHz
MODULATION TECHNOLOGY	MOFDM	DETECTOR FUNCTION	Peak / Average
INPUT POWER (SYSTEM)	120Vac, 60 Hz	ENVIRONMENTAL CONDITIONS	25 deg. C, 65 %RH, 982hPa
TESTED BY	Dean Wang	TEST MODE	A

ANTENNA POLARITY & TEST DISTANCE: HORIZONTAL AT 1 M								
NO.	FREQ. (MHz)	EMISSION LEVEL (dBuV/m)	LIMIT (dBuV/m)	MARGIN (dB)	ANTENNA HEIGHT (m)	TABLE ANGLE (Degree)	RAW VALUE (dBuV)	CORRECTION FACTOR (dB/m)
1	1566.00	43.87 PK	83.54	-39.67	1.00 H	329	13.13	30.74
2	1566.00	31.65 AV	63.54	-31.89	1.00 H	329	0.91	30.74
3	1584.00	45.48 PK	83.54	-38.06	1.00 H	231	14.71	30.77
4	1584.00	36.04 AV	63.54	-27.50	1.00 H	231	5.27	30.77
5	1590.00	44.85 PK	83.54	-38.69	1.00 H	327	14.07	30.78
6	1590.00	33.14 AV	63.54	-30.40	1.00 H	327	2.36	30.78
7	1596.00	44.58 PK	83.54	-38.96	1.00 H	232	13.8	30.78
8	1596.00	31.37 AV	63.54	-32.17	1.00 H	232	0.59	30.78
9	1608.00	43.03 PK	83.54	-40.51	1.00 H	325	12.23	30.8
10	1608.00	31.75 AV	63.54	-31.79	1.00 H	325	0.94	30.8

REMARKS:

1. Emission source for each frequency.

Frequency (MHz)	Emission Source		Spurious
1566.00	PHY	66M (PHY crystal)	66M/6 = 6M for PHY digital, 6M*261
1584.00	PHY	66M (PHY crystal)	528M (PLL), 528M*3
1590.00	PHY	66M (PHY crystal)	66M/6 = 6M for PHY digital, 6M*265
1596.00	MAC	12M (MAC crystal)	12M*133
1608.00	MAC	12M (MAC crystal)	12M*134

2. Emission level(dBuV/m)=Raw Value(dBuV) + Correction Factor(dB/m)

3. Correction Factor(dB/m) = Antenna Factor (dB/m) + Cable Factor (dB)

4. The other emission levels were very low against the limit.

5. Margin value = Emission level – Limit value.



A D T

EUT TEST CONDITION		MEASUREMENT DETAIL	
SUB-BAND	1 + 2 + 3	FREQUENCY RANGE	Above 1GHz
MODULATION TECHNOLOGY	MOFDM	DETECTOR FUNCTION	Peak / Average
INPUT POWER (SYSTEM)	120Vac, 60 Hz	ENVIRONMENTAL CONDITIONS	25 deg. C, 65 %RH, 982hPa
TESTED BY	Dean Wang	TEST MODE	A

ANTENNA POLARITY & TEST DISTANCE: VERTICAL AT 1 M								
NO.	FREQ. (MHz)	EMISSION LEVEL (dBuV/m)	LIMIT (dBuV/m)	MARGIN (dB)	ANTENNA HEIGHT (m)	TABLE ANGLE (Degree)	RAW VALUE (dBuV)	CORRECTION FACTOR (dB/m)
1	1566.00	44.82 PK	83.54	-38.72	1.00 V	249	14.08	30.74
2	1566.00	32.59 AV	63.54	-30.95	1.00 V	249	1.85	30.74
3	1584.00	46.99 PK	83.54	-36.55	1.00 V	252	16.22	30.77
4	1584.00	37.56 AV	63.54	-25.98	1.00 V	252	6.79	30.77
5	1590.00	46.64 PK	83.54	-36.90	1.00 V	247	15.86	30.78
6	1590.00	34.87 AV	63.54	-28.67	1.00 V	247	4.09	30.78
7	1596.00	46.17 PK	83.54	-37.37	1.00 V	234	15.39	30.78
8	1596.00	32.95 AV	63.54	-30.59	1.00 V	234	2.17	30.78
9	1608.00	45.04 PK	83.54	-38.50	1.00 V	248	14.23	30.8
10	1608.00	33.60 AV	63.54	-29.94	1.00 V	248	2.79	30.8

REMARKS:

1. Emission source for each frequency.

Frequency (MHz)	Emission Source		Spurious
1566.00	PHY	66M (PHY crystal)	66M/6 = 6M for PHY digital, 6M*261
1584.00	PHY	66M (PHY crystal)	528M (PLL), 528M*3
1590.00	PHY	66M (PHY crystal)	66M/6 = 6M for PHY digital, 6M*265
1596.00	MAC	12M (MAC crystal)	12M*133
1608.00	MAC	12M (MAC crystal)	12M*134

- Emission level(dBuV/m)=Raw Value(dBuV) + Correction Factor(dB/m)
- Correction Factor(dB/m) = Antenna Factor (dB/m) + Cable Factor (dB)
- The other emission levels were very low against the limit.
- Margin value = Emission level – Limit value.



A D T

EUT TEST CONDITION		MEASUREMENT DETAIL	
SUB-BAND	1 + 2 + 3	FREQUENCY RANGE	Above 1GHz
MODULATION TECHNOLOGY	MOFDM	DETECTOR FUNCTION	Peak / Average
INPUT POWER (SYSTEM)	120Vac, 60 Hz	ENVIRONMENTAL CONDITIONS	25 deg. C, 65 %RH, 982hPa
TESTED BY	Dean Wang	TEST MODE	B

ANTENNA POLARITY & TEST DISTANCE: HORIZONTAL AT 1 M								
NO.	FREQ. (MHz)	EMISSION LEVEL (dBuV/m)	LIMIT (dBuV/m)	MARGIN (dB)	ANTENNA HEIGHT (m)	TABLE ANGLE (Degree)	RAW VALUE (dBuV)	CORRECTION FACTOR (dB/m)
1	1566.00	43.75 PK	83.54	-39.79	1.00 H	332	13.01	30.74
2	1566.00	31.53 AV	63.54	-32.01	1.00 H	332	0.79	30.74
3	1584.00	45.29 PK	83.54	-38.25	1.00 H	234	14.52	30.77
4	1584.00	35.87 AV	63.54	-27.67	1.00 H	234	5.1	30.77
5	1590.00	44.67 PK	83.54	-38.87	1.00 H	331	13.89	30.78
6	1590.00	32.98 AV	63.54	-30.56	1.00 H	331	2.2	30.78
7	1596.00	44.42 PK	83.54	-39.12	1.00 H	235	13.64	30.78
8	1596.00	31.29 AV	63.54	-32.25	1.00 H	235	0.51	30.78
9	1608.00	42.87 PK	83.54	-40.67	1.00 H	330	12.07	30.8
10	1608.00	31.58 AV	63.54	-31.96	1.00 H	330	0.78	30.8

REMARKS:

1. Emission source for each frequency.

Frequency (MHz)	Emission Source		Spurious
1566.00	PHY	66M (PHY crystal)	66M/6 = 6M for PHY digital, 6M*261
1584.00	PHY	66M (PHY crystal)	528M (PLL), 528M*3
1590.00	PHY	66M (PHY crystal)	66M/6 = 6M for PHY digital, 6M*265
1596.00	MAC	12M (MAC crystal)	12M*133
1608.00	MAC	12M (MAC crystal)	12M*134

- Emission level(dBuV/m)=Raw Value(dBuV) + Correction Factor(dB/m)
- Correction Factor(dB/m) = Antenna Factor (dB/m) + Cable Factor (dB)
- The other emission levels were very low against the limit.
- Margin value = Emission level – Limit value.



A D T

EUT TEST CONDITION		MEASUREMENT DETAIL	
SUB-BAND	1 + 2 + 3	FREQUENCY RANGE	Above 1GHz
MODULATION TECHNOLOGY	MOFDM	DETECTOR FUNCTION	Peak / Average
INPUT POWER (SYSTEM)	120Vac, 60 Hz	ENVIRONMENTAL CONDITIONS	25 deg. C, 65 %RH, 982hPa
TESTED BY	Dean Wang	TEST MODE	B

ANTENNA POLARITY & TEST DISTANCE: VERTICAL AT 1 M								
NO.	FREQ. (MHz)	EMISSION LEVEL (dBuV/m)	LIMIT (dBuV/m)	MARGIN (dB)	ANTENNA HEIGHT (m)	TABLE ANGLE (Degree)	RAW VALUE (dBuV)	CORRECTION FACTOR (dB/m)
1	1566.00	44.64 PK	83.54	-38.90	1.00 V	247	13.9	30.74
2	1566.00	32.48 AV	63.54	-31.06	1.00 V	247	1.74	30.74
3	1584.00	46.78 PK	83.54	-36.76	1.00 V	258	16.01	30.77
4	1584.00	37.42 AV	63.54	-26.12	1.00 V	258	6.65	30.77
5	1590.00	46.48 PK	83.54	-37.06	1.00 V	251	15.7	30.78
6	1590.00	34.71 AV	63.54	-28.83	1.00 V	251	3.93	30.78
7	1596.00	45.98 PK	83.54	-37.56	1.00 V	238	15.2	30.78
8	1596.00	32.79 AV	63.54	-30.75	1.00 V	238	2.01	30.78
9	1608.00	44.88 PK	83.54	-38.66	1.00 V	253	14.08	30.8
10	1608.00	33.42 AV	63.54	-30.12	1.00 V	253	2.62	30.8

REMARKS:

1. Emission source for each frequency.

Frequency (MHz)	Emission Source		Spurious
1566.00	PHY	66M (PHY crystal)	66M/6 = 6M for PHY digital, 6M*261
1584.00	PHY	66M (PHY crystal)	528M (PLL), 528M*3
1590.00	PHY	66M (PHY crystal)	66M/6 = 6M for PHY digital, 6M*265
1596.00	MAC	12M (MAC crystal)	12M*133
1608.00	MAC	12M (MAC crystal)	12M*134

- Emission level(dBuV/m)=Raw Value(dBuV) + Correction Factor(dB/m)
- Correction Factor(dB/m) = Antenna Factor (dB/m) + Cable Factor (dB)
- The other emission levels were very low against the limit.
- Margin value = Emission level – Limit value.



A D T

EUT TEST CONDITION		MEASUREMENT DETAIL	
SUB-BAND	1 + 2 + 3	FREQUENCY RANGE	Above 1GHz
MODULATION TECHNOLOGY	MOFDM	DETECTOR FUNCTION	Peak / Average
INPUT POWER (SYSTEM)	120Vac, 60 Hz	ENVIRONMENTAL CONDITIONS	25 deg. C, 65 %RH, 982hPa
TESTED BY	Dean Wang	TEST MODE	C

ANTENNA POLARITY & TEST DISTANCE: HORIZONTAL AT 1 M								
NO.	FREQ. (MHz)	EMISSION LEVEL (dBuV/m)	LIMIT (dBuV/m)	MARGIN (dB)	ANTENNA HEIGHT (m)	TABLE ANGLE (Degree)	RAW VALUE (dBuV)	CORRECTION FACTOR (dB/m)
1	1566.00	43.99 PK	83.54	-39.55	1.00 H	332	13.25	30.74
2	1566.00	31.78 AV	63.54	-31.76	1.00 H	332	1.04	30.74
3	1584.00	45.61 PK	83.54	-37.93	1.00 H	237	14.84	30.77
4	1584.00	36.19 AV	63.54	-27.35	1.00 H	237	5.42	30.77
5	1590.00	44.98 PK	83.54	-38.56	1.00 H	236	14.2	30.78
6	1590.00	33.26 AV	63.54	-30.28	1.00 H	236	2.48	30.78
7	1596.00	44.75 PK	83.54	-38.79	1.00 H	239	13.97	30.78
8	1596.00	31.62 AV	63.54	-31.92	1.00 H	239	0.84	30.78
9	1608.00	43.17 PK	83.54	-40.37	1.00 H	328	12.37	30.8
10	1608.00	31.84 AV	63.54	-31.70	1.00 H	328	1.04	30.8

REMARKS:

1. Emission source for each frequency.

Frequency (MHz)	Emission Source		Spurious
1566.00	PHY	66M (PHY crystal)	66M/6 = 6M for PHY digital, 6M*261
1584.00	PHY	66M (PHY crystal)	528M (PLL), 528M*3
1590.00	PHY	66M (PHY crystal)	66M/6 = 6M for PHY digital, 6M*265
1596.00	MAC	12M (MAC crystal)	12M*133
1608.00	MAC	12M (MAC crystal)	12M*134

- Emission level(dBuV/m)=Raw Value(dBuV) + Correction Factor(dB/m)
- Correction Factor(dB/m) = Antenna Factor (dB/m) + Cable Factor (dB)
- The other emission levels were very low against the limit.
- Margin value = Emission level – Limit value.



A D T

EUT TEST CONDITION		MEASUREMENT DETAIL	
SUB-BAND	1 + 2 + 3	FREQUENCY RANGE	Above 1GHz
MODULATION TECHNOLOGY	MOFDM	DETECTOR FUNCTION	Peak / Average
INPUT POWER (SYSTEM)	120Vac, 60 Hz	ENVIRONMENTAL CONDITIONS	25 deg. C, 65 %RH, 982hPa
TESTED BY	Dean Wang	TEST MODE	C

ANTENNA POLARITY & TEST DISTANCE: VERTICAL AT 1 M								
NO.	FREQ. (MHz)	EMISSION LEVEL (dBuV/m)	LIMIT (dBuV/m)	MARGIN (dB)	ANTENNA HEIGHT (m)	TABLE ANGLE (Degree)	RAW VALUE (dBuV)	CORRECTION FACTOR (dB/m)
1	1566.00	44.98 PK	83.54	-38.56	1.00 V	253	14.24	30.74
2	1566.00	32.72 AV	63.54	-30.82	1.00 V	253	1.98	30.74
3	1584.00	47.12 PK	83.54	-36.42	1.00 V	258	16.35	30.77
4	1584.00	37.73 AV	63.54	-25.81	1.00 V	258	6.96	30.77
5	1590.00	46.81 PK	83.54	-36.73	1.00 V	252	16.03	30.78
6	1590.00	34.98 AV	63.54	-28.56	1.00 V	252	4.2	30.78
7	1596.00	46.38 PK	83.54	-37.16	1.00 V	231	15.6	30.78
8	1596.00	33.17 AV	63.54	-30.37	1.00 V	231	2.39	30.78
9	1608.00	45.26 PK	83.54	-38.28	1.00 V	252	14.46	30.8
10	1608.00	33.81 AV	63.54	-29.73	1.00 V	252	3.01	30.8

REMARKS:

1. Emission source for each frequency.

Frequency (MHz)	Emission Source		Spurious
1566.00	PHY	66M (PHY crystal)	66M/6 = 6M for PHY digital, 6M*261
1584.00	PHY	66M (PHY crystal)	528M (PLL), 528M*3
1590.00	PHY	66M (PHY crystal)	66M/6 = 6M for PHY digital, 6M*265
1596.00	MAC	12M (MAC crystal)	12M*133
1608.00	MAC	12M (MAC crystal)	12M*134

- Emission level(dBuV/m)=Raw Value(dBuV) + Correction Factor(dB/m)
- Correction Factor(dB/m) = Antenna Factor (dB/m) + Cable Factor (dB)
- The other emission levels were very low against the limit.
- Margin value = Emission level – Limit value.



A D T

EUT TEST CONDITION		MEASUREMENT DETAIL	
SUB-BAND	1 + 2 + 3	FREQUENCY RANGE	Above 1GHz
MODULATION TECHNOLOGY	MOFDM	DETECTOR FUNCTION	Peak / Average
INPUT POWER (SYSTEM)	120Vac, 60 Hz	ENVIRONMENTAL CONDITIONS	25 deg. C, 65 %RH, 982hPa
TESTED BY	Dean Wang	TEST MODE	D

ANTENNA POLARITY & TEST DISTANCE: HORIZONTAL AT 1 M								
NO.	FREQ. (MHz)	EMISSION LEVEL (dBuV/m)	LIMIT (dBuV/m)	MARGIN (dB)	ANTENNA HEIGHT (m)	TABLE ANGLE (Degree)	RAW VALUE (dBuV)	CORRECTION FACTOR (dB/m)
1	1566.00	43.81 PK	83.54	-39.73	1.00 H	334	13.07	30.74
2	1566.00	31.62 AV	63.54	-31.92	1.00 H	334	0.88	30.74
3	1584.00	45.49 PK	83.54	-38.05	1.00 H	240	14.72	30.77
4	1584.00	36.06 AV	63.54	-27.48	1.00 H	240	5.29	30.77
5	1590.00	44.82 PK	83.54	-38.72	1.00 H	233	14.04	30.78
6	1590.00	33.08 AV	63.54	-30.46	1.00 H	233	2.3	30.78
7	1596.00	44.63 PK	83.54	-38.91	1.00 H	242	13.85	30.78
8	1596.00	31.51 AV	63.54	-32.03	1.00 H	242	0.73	30.78
9	1608.00	42.98 PK	83.54	-40.56	1.00 H	335	12.18	30.8
10	1608.00	31.67 AV	63.54	-31.87	1.00 H	335	0.87	30.8

REMARKS:

1. Emission source for each frequency.

Frequency (MHz)	Emission Source		Spurious
1566.00	PHY	66M (PHY crystal)	66M/6 = 6M for PHY digital, 6M*261
1584.00	PHY	66M (PHY crystal)	528M (PLL), 528M*3
1590.00	PHY	66M (PHY crystal)	66M/6 = 6M for PHY digital, 6M*265
1596.00	MAC	12M (MAC crystal)	12M*133
1608.00	MAC	12M (MAC crystal)	12M*134

- Emission level(dBuV/m)=Raw Value(dBuV) + Correction Factor(dB/m)
- Correction Factor(dB/m) = Antenna Factor (dB/m) + Cable Factor (dB)
- The other emission levels were very low against the limit.
- Margin value = Emission level – Limit value.



A D T

EUT TEST CONDITION		MEASUREMENT DETAIL	
SUB-BAND	1 + 2 + 3	FREQUENCY RANGE	Above 1GHz
MODULATION TECHNOLOGY	MOFDM	DETECTOR FUNCTION	Peak / Average
INPUT POWER (SYSTEM)	120Vac, 60 Hz	ENVIRONMENTAL CONDITIONS	25 deg. C, 65 %RH, 982hPa
TESTED BY	Dean Wang	TEST MODE	D

ANTENNA POLARITY & TEST DISTANCE: VERTICAL AT 1 M								
NO.	FREQ. (MHz)	EMISSION LEVEL (dBuV/m)	LIMIT (dBuV/m)	MARGIN (dB)	ANTENNA HEIGHT (m)	TABLE ANGLE (Degree)	RAW VALUE (dBuV)	CORRECTION FACTOR (dB/m)
1	1566.00	44.76 PK	83.54	-38.78	1.00 V	258	14.02	30.74
2	1566.00	32.53 AV	63.54	-31.01	1.00 V	258	1.79	30.74
3	1584.00	46.89 PK	83.54	-36.65	1.00 V	263	16.12	30.77
4	1584.00	37.55 AV	63.54	-25.99	1.00 V	263	6.78	30.77
5	1590.00	46.62 PK	83.54	-36.92	1.00 V	256	15.84	30.78
6	1590.00	34.77 AV	63.54	-28.77	1.00 V	256	3.99	30.78
7	1596.00	46.22 PK	83.54	-37.32	1.00 V	235	15.44	30.78
8	1596.00	33.01 AV	63.54	-30.53	1.00 V	235	2.23	30.78
9	1608.00	45.09 PK	83.54	-38.45	1.00 V	261	14.29	30.8
10	1608.00	33.68 AV	63.54	-29.86	1.00 V	261	2.88	30.8

REMARKS:

1. Emission source for each frequency.

Frequency (MHz)	Emission Source		Spurious
1566.00	PHY	66M (PHY crystal)	66M/6 = 6M for PHY digital, 6M*261
1584.00	PHY	66M (PHY crystal)	528M (PLL), 528M*3
1590.00	PHY	66M (PHY crystal)	66M/6 = 6M for PHY digital, 6M*265
1596.00	MAC	12M (MAC crystal)	12M*133
1608.00	MAC	12M (MAC crystal)	12M*134

- Emission level(dBuV/m)=Raw Value(dBuV) + Correction Factor(dB/m)
- Correction Factor(dB/m) = Antenna Factor (dB/m) + Cable Factor (dB)
- The other emission levels were very low against the limit.
- Margin value = Emission level – Limit value.



A D T

EUT TEST CONDITION		MEASUREMENT DETAIL	
SUB-BAND	1 + 2 + 3	FREQUENCY RANGE	Above 1GHz
MODULATION TECHNOLOGY	MOFDM	DETECTOR FUNCTION	Peak / Average
INPUT POWER (SYSTEM)	120Vac, 60 Hz	ENVIRONMENTAL CONDITIONS	25 deg. C, 65 %RH, 982hPa
TESTED BY	Dean Wang	TEST MODE	E

ANTENNA POLARITY & TEST DISTANCE: HORIZONTAL AT 1 M								
NO.	FREQ. (MHz)	EMISSION LEVEL (dBuV/m)	LIMIT (dBuV/m)	MARGIN (dB)	ANTENNA HEIGHT (m)	TABLE ANGLE (Degree)	RAW VALUE (dBuV)	CORRECTION FACTOR (dB/m)
1	1566.00	43.02 PK	83.54	-40.52	1.00 H	338	12.28	30.74
2	1566.00	30.97 AV	63.54	-32.57	1.00 H	338	0.23	30.74
3	1578.00	43.72 PK	83.54	-39.82	1.00 H	350	12.96	30.76
4	1578.00	31.20 AV	63.54	-32.34	1.00 H	350	0.44	30.76
5	1584.00	44.28 PK	83.54	-39.26	1.00 H	253	13.51	30.77
6	1584.00	34.92 AV	63.54	-28.62	1.00 H	253	4.15	30.77
7	1590.00	43.68 PK	83.54	-39.86	1.00 H	237	12.9	30.78
8	1590.00	32.04 AV	63.54	-31.50	1.00 H	237	1.26	30.78
9	1596.00	43.57 PK	83.54	-39.97	1.00 H	235	12.79	30.78
10	1596.00	30.43 AV	63.54	-33.11	1.00 H	235	-0.35	30.78
11	1602.00	44.44 PK	83.54	-39.10	1.00 H	343	13.65	30.79
12	1602.00	32.18 AV	63.54	-31.36	1.00 H	343	1.39	30.79
13	1608.00	43.54 PK	83.54	-40.00	1.00 H	342	12.74	30.8
14	1608.00	32.31 AV	63.54	-31.23	1.00 H	342	1.51	30.8

REMARKS:

1. Emission source for each frequency.

Frequency (MHz)	Emission Source		Spurious
1566.00	PHY	66M (PHY crystal)	66M/6 = 6M for PHY digital, 6M*261
1578.00	PHY	66M (PHY crystal)	66M/6 = 6M for PHY digital, 6M*263
1584.00	PHY	66M (PHY crystal)	528M (PLL), 528M*3
1590.00	PHY	66M (PHY crystal)	66M/6 = 6M for PHY digital, 6M*265
1596.00	MAC	12M (MAC crystal)	12M*133
1602.00	PHY	66M (PHY crystal)	66M/6 = 6M for PHY digital, 6M*267
1608.00	MAC	12M (MAC crystal)	12M*134

2. Emission level(dBuV/m)=Raw Value(dBuV) + Correction Factor(dB/m)

3. Correction Factor(dB/m) = Antenna Factor (dB/m) + Cable Factor (dB)

4. The other emission levels were very low against the limit.

5. Margin value = Emission level – Limit value.



A D T

EUT TEST CONDITION		MEASUREMENT DETAIL	
SUB-BAND	1 + 2 + 3	FREQUENCY RANGE	Above 1GHz
MODULATION TECHNOLOGY	MOFDM	DETECTOR FUNCTION	Peak / Average
INPUT POWER (SYSTEM)	120Vac, 60 Hz	ENVIRONMENTAL CONDITIONS	25 deg. C, 65 %RH, 982hPa
TESTED BY	Dean Wang	TEST MODE	E

ANTENNA POLARITY & TEST DISTANCE: VERTICAL AT 1 M								
NO.	FREQ. (MHz)	EMISSION LEVEL (dBuV/m)	LIMIT (dBuV/m)	MARGIN (dB)	ANTENNA HEIGHT (m)	TABLE ANGLE (Degree)	RAW VALUE (dBuV)	CORRECTION FACTOR (dB/m)
1	1566.00	44.08 PK	83.54	-39.46	1.00 V	266	13.34	30.74
2	1566.00	31.81 AV	63.54	-31.73	1.00 V	266	1.07	30.74
3	1578.00	45.66 PK	83.54	-37.88	1.00 V	249	14.9	30.76
4	1578.00	33.03 AV	63.54	-30.51	1.00 V	249	2.27	30.76
5	1584.00	45.68 PK	83.54	-37.86	1.00 V	267	14.91	30.77
6	1584.00	36.43 AV	63.54	-27.11	1.00 V	267	5.66	30.77
7	1590.00	45.43 PK	83.54	-38.11	1.00 V	261	14.65	30.78
8	1590.00	33.62 AV	63.54	-29.92	1.00 V	261	2.84	30.78
9	1596.00	45.03 PK	83.54	-38.51	1.00 V	242	14.25	30.78
10	1596.00	32.08 AV	63.54	-31.46	1.00 V	242	1.3	30.78
11	1602.00	45.94 PK	83.54	-37.60	1.00 V	246	15.15	30.79
12	1602.00	33.70 AV	63.54	-29.84	1.00 V	246	2.91	30.79
13	1608.00	45.73 PK	83.54	-37.81	1.00 V	267	14.93	30.8
14	1608.00	34.26 AV	63.54	-29.28	1.00 V	267	3.46	30.8

REMARKS:

1. Emission source for each frequency.

Frequency (MHz)	Emission Source		Spurious
1566.00	PHY	66M (PHY crystal)	66M/6 = 6M for PHY digital, 6M*261
1578.00	PHY	66M (PHY crystal)	66M/6 = 6M for PHY digital, 6M*263
1584.00	PHY	66M (PHY crystal)	528M (PLL), 528M*3
1590.00	PHY	66M (PHY crystal)	66M/6 = 6M for PHY digital, 6M*265
1596.00	MAC	12M (MAC crystal)	12M*133
1602.00	PHY	66M (PHY crystal)	66M/6 = 6M for PHY digital, 6M*267
1608.00	MAC	12M (MAC crystal)	12M*134

- Emission level(dBuV/m)=Raw Value(dBuV) + Correction Factor(dB/m)
- Correction Factor(dB/m) = Antenna Factor (dB/m) + Cable Factor (dB)
- The other emission levels were very low against the limit.
- Margin value = Emission level – Limit value.



A D T

EUT TEST CONDITION		MEASUREMENT DETAIL	
SUB-BAND	1 + 2 + 3	FREQUENCY RANGE	Above 1GHz
MODULATION TECHNOLOGY	MOFDM	DETECTOR FUNCTION	Peak / Average
INPUT POWER (SYSTEM)	120Vac, 60 Hz	ENVIRONMENTAL CONDITIONS	25 deg. C, 65 %RH, 982hPa
TESTED BY	Dean Wang	TEST MODE	F

ANTENNA POLARITY & TEST DISTANCE: HORIZONTAL AT 1 M								
NO.	FREQ. (MHz)	EMISSION LEVEL (dBuV/m)	LIMIT (dBuV/m)	MARGIN (dB)	ANTENNA HEIGHT (m)	TABLE ANGLE (Degree)	RAW VALUE (dBuV)	CORRECTION FACTOR (dB/m)
1	1566.00	42.89 PK	83.54	-40.65	1.00 H	341	12.15	30.74
2	1566.00	30.86 AV	63.54	-32.68	1.00 H	341	0.12	30.74
3	1578.00	43.59 PK	83.54	-39.95	1.00 H	344	12.83	30.76
4	1578.00	31.02 AV	63.54	-32.52	1.00 H	344	0.26	30.76
5	1584.00	44.12 PK	83.54	-39.42	1.00 H	261	13.35	30.77
6	1584.00	34.78 AV	63.54	-28.76	1.00 H	261	4.01	30.77
7	1590.00	43.52 PK	83.54	-40.02	1.00 H	242	12.74	30.78
8	1590.00	31.87 AV	63.54	-31.67	1.00 H	242	1.09	30.78
9	1596.00	43.44 PK	83.54	-40.10	1.00 H	238	12.66	30.78
10	1596.00	30.29 AV	63.54	-33.25	1.00 H	238	-0.49	30.78
11	1602.00	44.35 PK	83.54	-39.19	1.00 H	338	13.56	30.79
12	1602.00	32.11 AV	63.54	-31.43	1.00 H	338	1.32	30.79
13	1608.00	43.36 PK	83.54	-40.18	1.00 H	334	12.56	30.8
14	1608.00	32.17 AV	63.54	-31.37	1.00 H	334	1.37	30.8

REMARKS:

1. Emission source for each frequency.

Frequency (MHz)	Emission Source		Spurious
1566.00	PHY	66M (PHY crystal)	66M/6 = 6M for PHY digital, 6M*261
1578.00	PHY	66M (PHY crystal)	66M/6 = 6M for PHY digital, 6M*263
1584.00	PHY	66M (PHY crystal)	528M (PLL), 528M*3
1590.00	PHY	66M (PHY crystal)	66M/6 = 6M for PHY digital, 6M*265
1596.00	MAC	12M (MAC crystal)	12M*133
1602.00	PHY	66M (PHY crystal)	66M/6 = 6M for PHY digital, 6M*267
1608.00	MAC	12M (MAC crystal)	12M*134

- Emission level(dBuV/m)=Raw Value(dBuV) + Correction Factor(dB/m)
- Correction Factor(dB/m) = Antenna Factor (dB/m) + Cable Factor (dB)
- The other emission levels were very low against the limit.
- Margin value = Emission level – Limit value.



A D T

EUT TEST CONDITION		MEASUREMENT DETAIL	
SUB-BAND	1 + 2 + 3	FREQUENCY RANGE	Above 1GHz
MODULATION TECHNOLOGY	MOFDM	DETECTOR FUNCTION	Peak / Average
INPUT POWER (SYSTEM)	120Vac, 60 Hz	ENVIRONMENTAL CONDITIONS	25 deg. C, 65 %RH, 982hPa
TESTED BY	Dean Wang	TEST MODE	F

ANTENNA POLARITY & TEST DISTANCE: VERTICAL AT 1 M								
NO.	FREQ. (MHz)	EMISSION LEVEL (dBuV/m)	LIMIT (dBuV/m)	MARGIN (dB)	ANTENNA HEIGHT (m)	TABLE ANGLE (Degree)	RAW VALUE (dBuV)	CORRECTION FACTOR (dB/m)
1	1566.00	43.82 PK	83.54	-39.72	1.00 V	262	13.08	30.74
2	1566.00	31.63 AV	63.54	-31.91	1.00 V	262	0.89	30.74
3	1578.00	45.47 PK	83.54	-38.07	1.00 V	255	14.71	30.76
4	1578.00	32.81 AV	63.54	-30.73	1.00 V	255	2.05	30.76
5	1584.00	45.52 PK	83.54	-38.02	1.00 V	271	14.75	30.77
6	1584.00	36.31 AV	63.54	-27.23	1.00 V	271	5.54	30.77
7	1590.00	45.26 PK	83.54	-38.28	1.00 V	266	14.48	30.78
8	1590.00	33.44 AV	63.54	-30.10	1.00 V	266	2.66	30.78
9	1596.00	44.87 PK	83.54	-38.67	1.00 V	247	14.09	30.78
10	1596.00	31.95 AV	63.54	-31.59	1.00 V	247	1.17	30.78
11	1602.00	45.83 PK	83.54	-37.71	1.00 V	251	15.04	30.79
12	1602.00	33.59 AV	63.54	-29.95	1.00 V	251	2.8	30.79
13	1608.00	45.56 PK	83.54	-37.98	1.00 V	273	14.76	30.8
14	1608.00	34.11 AV	63.54	-29.43	1.00 V	273	3.31	30.8

REMARKS:

1. Emission source for each frequency.

Frequency (MHz)	Emission Source		Spurious
1566.00	PHY	66M (PHY crystal)	66M/6 = 6M for PHY digital, 6M*261
1578.00	PHY	66M (PHY crystal)	66M/6 = 6M for PHY digital, 6M*263
1584.00	PHY	66M (PHY crystal)	528M (PLL), 528M*3
1590.00	PHY	66M (PHY crystal)	66M/6 = 6M for PHY digital, 6M*265
1596.00	MAC	12M (MAC crystal)	12M*133
1602.00	PHY	66M (PHY crystal)	66M/6 = 6M for PHY digital, 6M*267
1608.00	MAC	12M (MAC crystal)	12M*134

2. Emission level(dBuV/m)=Raw Value(dBuV) + Correction Factor(dB/m)

3. Correction Factor(dB/m) = Antenna Factor (dB/m) + Cable Factor (dB)

4. The other emission levels were very low against the limit.

5. Margin value = Emission level – Limit value.



A D T

EUT TEST CONDITION		MEASUREMENT DETAIL	
SUB-BAND	1 + 2 + 3	FREQUENCY RANGE	Above 1GHz
MODULATION TECHNOLOGY	MOFDM	DETECTOR FUNCTION	Peak / Average
INPUT POWER (SYSTEM)	120Vac, 60 Hz	ENVIRONMENTAL CONDITIONS	25 deg. C, 65 %RH, 982hPa
TESTED BY	Dean Wang	TEST MODE	G

ANTENNA POLARITY & TEST DISTANCE: HORIZONTAL AT 1 M								
NO.	FREQ. (MHz)	EMISSION LEVEL (dBuV/m)	LIMIT (dBuV/m)	MARGIN (dB)	ANTENNA HEIGHT (m)	TABLE ANGLE (Degree)	RAW VALUE (dBuV)	CORRECTION FACTOR (dB/m)
1	1566.00	42.93 PK	83.54	-40.61	1.00 H	341	12.19	30.74
2	1566.00	30.89 AV	63.54	-32.65	1.00 H	341	0.15	30.74
3	1578.00	43.56 PK	83.54	-39.98	1.00 H	342	12.8	30.76
4	1578.00	31.04 AV	63.54	-32.50	1.00 H	342	0.28	30.76
5	1584.00	44.16 PK	83.54	-39.38	1.00 H	261	13.39	30.77
6	1584.00	34.75 AV	63.54	-28.79	1.00 H	261	3.98	30.77
7	1590.00	43.53 PK	83.54	-40.01	1.00 H	242	12.75	30.78
8	1590.00	31.86 AV	63.54	-31.68	1.00 H	242	1.08	30.78
9	1596.00	43.42 PK	83.54	-40.12	1.00 H	239	12.64	30.78
10	1596.00	30.31 AV	63.54	-33.23	1.00 H	239	-0.47	30.78
11	1602.00	44.35 PK	83.54	-39.19	1.00 H	336	13.56	30.79
12	1602.00	32.09 AV	63.54	-31.45	1.00 H	336	1.3	30.79
13	1608.00	43.36 PK	83.54	-40.18	1.00 H	327	12.56	30.8
14	1608.00	32.15 AV	63.54	-31.39	1.00 H	327	1.35	30.8

REMARKS:

1. Emission source for each frequency.

Frequency (MHz)	Emission Source		Spurious
1566.00	PHY	66M (PHY crystal)	66M/6 = 6M for PHY digital, 6M*261
1578.00	PHY	66M (PHY crystal)	66M/6 = 6M for PHY digital, 6M*263
1584.00	PHY	66M (PHY crystal)	528M (PLL), 528M*3
1590.00	PHY	66M (PHY crystal)	66M/6 = 6M for PHY digital, 6M*265
1596.00	MAC	12M (MAC crystal)	12M*133
1602.00	PHY	66M (PHY crystal)	66M/6 = 6M for PHY digital, 6M*267
1608.00	MAC	12M (MAC crystal)	12M*134

- Emission level(dBuV/m)=Raw Value(dBuV) + Correction Factor(dB/m)
- Correction Factor(dB/m) = Antenna Factor (dB/m) + Cable Factor (dB)
- The other emission levels were very low against the limit.
- Margin value = Emission level – Limit value.



EUT TEST CONDITION		MEASUREMENT DETAIL	
SUB-BAND	1 + 2 + 3	FREQUENCY RANGE	Above 1GHz
MODULATION TECHNOLOGY	MOFDM	DETECTOR FUNCTION	Peak / Average
INPUT POWER (SYSTEM)	120Vac, 60 Hz	ENVIRONMENTAL CONDITIONS	25 deg. C, 65 %RH, 982hPa
TESTED BY	Dean Wang	TEST MODE	G

ANTENNA POLARITY & TEST DISTANCE: VERTICAL AT 1 M								
NO.	FREQ. (MHz)	EMISSION LEVEL (dBuV/m)	LIMIT (dBuV/m)	MARGIN (dB)	ANTENNA HEIGHT (m)	TABLE ANGLE (Degree)	RAW VALUE (dBuV)	CORRECTION FACTOR (dB/m)
1	1566.00	43.96 PK	83.54	-39.58	1.00 V	262	13.22	30.74
2	1566.00	31.67 AV	63.54	-31.87	1.00 V	262	0.93	30.74
3	1578.00	45.49 PK	83.54	-38.05	1.00 V	253	14.73	30.76
4	1578.00	32.88 AV	63.54	-30.66	1.00 V	253	2.12	30.76
5	1584.00	45.53 PK	83.54	-38.01	1.00 V	269	14.76	30.77
6	1584.00	36.29 AV	63.54	-27.25	1.00 V	269	5.52	30.77
7	1590.00	45.28 PK	83.54	-38.26	1.00 V	266	14.5	30.78
8	1590.00	33.47 AV	63.54	-30.07	1.00 V	266	2.69	30.78
9	1596.00	44.86 PK	83.54	-38.68	1.00 V	248	14.08	30.78
10	1596.00	31.95 AV	63.54	-31.59	1.00 V	248	1.17	30.78
11	1602.00	45.81 PK	83.54	-37.73	1.00 V	251	15.02	30.79
12	1602.00	33.56 AV	63.54	-29.98	1.00 V	251	2.77	30.79
13	1608.00	45.56 PK	83.54	-37.98	1.00 V	272	14.76	30.8
14	1608.00	34.07 AV	63.54	-29.47	1.00 V	272	3.27	30.8

REMARKS:

1. Emission source for each frequency.

Frequency (MHz)	Emission Source		Spurious
1566.00	PHY	66M (PHY crystal)	66M/6 = 6M for PHY digital, 6M*261
1578.00	PHY	66M (PHY crystal)	66M/6 = 6M for PHY digital, 6M*263
1584.00	PHY	66M (PHY crystal)	528M (PLL), 528M*3
1590.00	PHY	66M (PHY crystal)	66M/6 = 6M for PHY digital, 6M*265
1596.00	MAC	12M (MAC crystal)	12M*133
1602.00	PHY	66M (PHY crystal)	66M/6 = 6M for PHY digital, 6M*267
1608.00	MAC	12M (MAC crystal)	12M*134

- Emission level(dBuV/m)=Raw Value(dBuV) + Correction Factor(dB/m)
- Correction Factor(dB/m) = Antenna Factor (dB/m) + Cable Factor (dB)
- The other emission levels were very low against the limit.
- Margin value = Emission level – Limit value.



A D T

EUT TEST CONDITION		MEASUREMENT DETAIL	
SUB-BAND	1 + 2 + 3	FREQUENCY RANGE	Above 1GHz
MODULATION TECHNOLOGY	MOFDM	DETECTOR FUNCTION	Peak / Average
INPUT POWER (SYSTEM)	120Vac, 60 Hz	ENVIRONMENTAL CONDITIONS	25 deg. C, 65 %RH, 982hPa
TESTED BY	Dean Wang	TEST MODE	H

ANTENNA POLARITY & TEST DISTANCE: HORIZONTAL AT 1 M								
NO.	FREQ. (MHz)	EMISSION LEVEL (dBuV/m)	LIMIT (dBuV/m)	MARGIN (dB)	ANTENNA HEIGHT (m)	TABLE ANGLE (Degree)	RAW VALUE (dBuV)	CORRECTION FACTOR (dB/m)
1	1566.00	42.78 PK	83.54	-40.76	1.00 H	343	12.04	30.74
2	1566.00	30.71 AV	63.54	-32.83	1.00 H	343	-0.03	30.74
3	1578.00	43.42 PK	83.54	-40.12	1.00 H	351	12.66	30.76
4	1578.00	30.88 AV	63.54	-32.66	1.00 H	351	0.12	30.76
5	1584.00	43.99 PK	83.54	-39.55	1.00 H	266	13.22	30.77
6	1584.00	34.67 AV	63.54	-28.87	1.00 H	266	3.9	30.77
7	1590.00	43.43 PK	83.54	-40.11	1.00 H	252	12.65	30.78
8	1590.00	31.78 AV	63.54	-31.76	1.00 H	252	1	30.78
9	1596.00	43.38 PK	83.54	-40.16	1.00 H	241	12.6	30.78
10	1596.00	30.22 AV	63.54	-33.32	1.00 H	241	-0.56	30.78
11	1602.00	44.19 PK	83.54	-39.35	1.00 H	345	13.4	30.79
12	1602.00	31.98 AV	63.54	-31.56	1.00 H	345	1.19	30.79
13	1608.00	43.28 PK	83.54	-40.26	1.00 H	339	12.48	30.8
14	1608.00	32.04 AV	63.54	-31.50	1.00 H	339	1.24	30.8

REMARKS:

1. Emission source for each frequency.

Frequency (MHz)	Emission Source		Spurious
1566.00	PHY	66M (PHY crystal)	66M/6 = 6M for PHY digital, 6M*261
1578.00	PHY	66M (PHY crystal)	66M/6 = 6M for PHY digital, 6M*263
1584.00	PHY	66M (PHY crystal)	528M (PLL), 528M*3
1590.00	PHY	66M (PHY crystal)	66M/6 = 6M for PHY digital, 6M*265
1596.00	MAC	12M (MAC crystal)	12M*133
1602.00	PHY	66M (PHY crystal)	66M/6 = 6M for PHY digital, 6M*267
1608.00	MAC	12M (MAC crystal)	12M*134

- Emission level(dBuV/m)=Raw Value(dBuV) + Correction Factor(dB/m)
- Correction Factor(dB/m) = Antenna Factor (dB/m) + Cable Factor (dB)
- The other emission levels were very low against the limit.
- Margin value = Emission level – Limit value.



EUT TEST CONDITION		MEASUREMENT DETAIL	
SUB-BAND	1 + 2 + 3	FREQUENCY RANGE	Above 1GHz
MODULATION TECHNOLOGY	MOFDM	DETECTOR FUNCTION	Peak / Average
INPUT POWER (SYSTEM)	120Vac, 60 Hz	ENVIRONMENTAL CONDITIONS	25 deg. C, 65 %RH, 982hPa
TESTED BY	Dean Wang	TEST MODE	H

ANTENNA POLARITY & TEST DISTANCE: VERTICAL AT 1 M								
NO.	FREQ. (MHz)	EMISSION LEVEL (dBuV/m)	LIMIT (dBuV/m)	MARGIN (dB)	ANTENNA HEIGHT (m)	TABLE ANGLE (Degree)	RAW VALUE (dBuV)	CORRECTION FACTOR (dB/m)
1	1566.00	43.76 PK	83.54	-39.78	1.00 V	263	13.02	30.74
2	1566.00	31.57 AV	63.54	-31.97	1.00 V	263	0.83	30.74
3	1578.00	45.61 PK	83.54	-37.93	1.00 V	258	14.85	30.76
4	1578.00	32.92 AV	63.54	-30.62	1.00 V	258	2.16	30.76
5	1584.00	45.63 PK	83.54	-37.91	1.00 V	278	14.86	30.77
6	1584.00	36.42 AV	63.54	-27.12	1.00 V	278	5.65	30.77
7	1590.00	45.33 PK	83.54	-38.21	1.00 V	253	14.55	30.78
8	1590.00	33.51 AV	63.54	-30.03	1.00 V	253	2.73	30.78
9	1596.00	44.75 PK	83.54	-38.79	1.00 V	252	13.97	30.78
10	1596.00	31.87 AV	63.54	-31.67	1.00 V	252	1.09	30.78
11	1602.00	45.69 PK	83.54	-37.85	1.00 V	259	14.9	30.79
12	1602.00	33.42 AV	63.54	-30.12	1.00 V	259	2.63	30.79
13	1608.00	45.42 PK	83.54	-38.12	1.00 V	265	14.62	30.8
14	1608.00	33.98 AV	63.54	-29.56	1.00 V	265	3.18	30.8

REMARKS:

1. Emission source for each frequency.

Frequency (MHz)	Emission Source		Spurious
1566.00	PHY	66M (PHY crystal)	66M/6 = 6M for PHY digital, 6M*261
1578.00	PHY	66M (PHY crystal)	66M/6 = 6M for PHY digital, 6M*263
1584.00	PHY	66M (PHY crystal)	528M (PLL), 528M*3
1590.00	PHY	66M (PHY crystal)	66M/6 = 6M for PHY digital, 6M*265
1596.00	MAC	12M (MAC crystal)	12M*133
1602.00	PHY	66M (PHY crystal)	66M/6 = 6M for PHY digital, 6M*267
1608.00	MAC	12M (MAC crystal)	12M*134

2. Emission level(dBuV/m)=Raw Value(dBuV) + Correction Factor(dB/m)

3. Correction Factor(dB/m) = Antenna Factor (dB/m) + Cable Factor (dB)

4. The other emission levels were very low against the limit.

5. Margin value = Emission level – Limit value.



A D T

EMISSIONS FROM NOTEBOOK

EUT TEST CONDITION		MEASUREMENT DETAIL	
SUB-BAND	1 + 2 + 3	FREQUENCY RANGE	Above 1GHz
MODULATION TECHNOLOGY	MOFDM	DETECTOR FUNCTION	Peak / Average
INPUT POWER (SYSTEM)	120Vac, 60 Hz	ENVIRONMENTAL CONDITIONS	25 deg. C, 65 %RH, 982hPa
TESTED BY	Dean Wang	TEST MODE	A

ANTENNA POLARITY & TEST DISTANCE: HORIZONTAL AT 1 M								
NO.	FREQ. (MHz)	EMISSION LEVEL (dBuV/m)	LIMIT (dBuV/m)	MARGIN (dB)	ANTENNA HEIGHT (m)	TABLE ANGLE (Degree)	RAW VALUE (dBuV)	CORRECTION FACTOR (dB/m)
1	1212.50	46.76 PK	83.54	-36.78	1.00 H	272	16.87	29.89
2	1212.50	42.33 AV	63.54	-21.21	1.00 H	272	12.44	29.89
3	1220.00	45.42 PK	83.54	-38.12	1.00 H	297	15.51	29.91
4	1220.00	33.19 AV	63.54	-30.35	1.00 H	297	3.28	29.91
5	1560.00	45.98 PK	83.54	-37.56	1.00 H	327	15.25	30.73
6	1560.00	31.96 AV	63.54	-31.58	1.00 H	327	1.23	30.73
7	1569.00	46.76 PK	83.54	-36.78	1.00 H	301	16.01	30.75
8	1569.00	39.91 AV	63.54	-23.63	1.00 H	301	9.16	30.75
9	1600.00	42.59 PK	83.54	-40.95	1.00 H	270	11.8	30.79
10	1600.00	31.91 AV	63.54	-31.63	1.00 H	270	1.12	30.79
ANTENNA POLARITY & TEST DISTANCE: VERTICAL AT 1 M								
NO.	FREQ. (MHz)	EMISSION LEVEL (dBuV/m)	LIMIT (dBuV/m)	MARGIN (dB)	ANTENNA HEIGHT (m)	TABLE ANGLE (Degree)	RAW VALUE (dBuV)	CORRECTION FACTOR (dB/m)
1	1212.50	49.07 PK	83.54	-34.47	1.00 V	280	19.18	29.89
2	1212.50	44.79 AV	63.54	-18.75	1.00 V	280	14.9	29.89
3	1220.00	43.05 PK	83.54	-40.49	1.00 V	270	13.14	29.91
4	1220.00	30.68 AV	63.54	-32.86	1.00 V	270	0.77	29.91
5	1560.00	47.22 PK	83.54	-36.32	1.00 V	247	16.49	30.73
6	1560.00	33.10 AV	63.54	-30.44	1.00 V	247	2.37	30.73
7	1569.00	45.65 PK	83.54	-37.89	1.00 V	307	14.9	30.75
8	1569.00	38.89 AV	63.54	-24.65	1.00 V	307	8.14	30.75
9	1600.00	46.15 PK	83.54	-37.39	1.00 V	210	15.36	30.79
10	1600.00	35.50 AV	63.54	-28.04	1.00 V	210	4.71	30.79

REMARKS:

1. Emission level(dBuV/m)=Raw Value(dBuV) + Correction Factor(dB/m)
2. Correction Factor(dB/m) = Antenna Factor (dB/m) + Cable Factor (dB)
3. The other emission levels were very low against the limit.
4. Margin value = Emission level – Limit value.



A D T

EUT TEST CONDITION		MEASUREMENT DETAIL	
SUB-BAND	1 + 2 + 3	FREQUENCY RANGE	Above 1GHz
MODULATION TECHNOLOGY	MOFDM	DETECTOR FUNCTION	Peak / Average
INPUT POWER (SYSTEM)	120Vac, 60 Hz	ENVIRONMENTAL CONDITIONS	25 deg. C, 65 %RH, 982hPa
TESTED BY	Dean Wang	TEST MODE	B

ANTENNA POLARITY & TEST DISTANCE: HORIZONTAL AT 1 M								
NO.	FREQ. (MHz)	EMISSION LEVEL (dBuV/m)	LIMIT (dBuV/m)	MARGIN (dB)	ANTENNA HEIGHT (m)	TABLE ANGLE (Degree)	RAW VALUE (dBuV)	CORRECTION FACTOR (dB/m)
1	1212.50	46.59 PK	83.54	-36.95	1.00 H	274	16.7	29.89
2	1212.50	42.18 AV	63.54	-21.36	1.00 H	274	12.29	29.89
3	1220.00	45.28 PK	83.54	-38.26	1.00 H	299	15.37	29.91
4	1220.00	33.07 AV	63.54	-30.47	1.00 H	299	3.16	29.91
5	1560.00	45.82 PK	83.54	-37.72	1.00 H	324	15.09	30.73
6	1560.00	31.79 AV	63.54	-31.75	1.00 H	324	1.06	30.73
7	1569.00	46.61 PK	83.54	-36.93	1.00 H	308	15.86	30.75
8	1569.00	39.76 AV	63.54	-23.78	1.00 H	308	9.01	30.75
9	1600.00	42.43 PK	83.54	-41.11	1.00 H	273	11.64	30.79
10	1600.00	31.76 AV	63.54	-31.78	1.00 H	273	0.97	30.79
ANTENNA POLARITY & TEST DISTANCE: VERTICAL AT 1 M								
NO.	FREQ. (MHz)	EMISSION LEVEL (dBuV/m)	LIMIT (dBuV/m)	MARGIN (dB)	ANTENNA HEIGHT (m)	TABLE ANGLE (Degree)	RAW VALUE (dBuV)	CORRECTION FACTOR (dB/m)
1	1212.50	48.89 PK	83.54	-34.65	1.00 V	282	19	29.89
2	1212.50	44.68 AV	63.54	-18.86	1.00 V	282	14.79	29.89
3	1220.00	42.92 PK	83.54	-40.62	1.00 V	273	13.01	29.91
4	1220.00	30.56 AV	63.54	-32.98	1.00 V	273	0.65	29.91
5	1560.00	47.08 PK	83.54	-36.46	1.00 V	244	16.35	30.73
6	1560.00	32.96 AV	63.54	-30.58	1.00 V	244	2.23	30.73
7	1569.00	45.52 PK	83.54	-38.02	1.00 V	304	14.77	30.75
8	1569.00	38.78 AV	63.54	-24.76	1.00 V	304	8.03	30.75
9	1600.00	45.97 PK	83.54	-37.57	1.00 V	208	15.18	30.79
10	1600.00	35.32 AV	63.54	-28.22	1.00 V	208	4.53	30.79

REMARKS:

1. Emission level(dBuV/m)=Raw Value(dBuV) + Correction Factor(dB/m)
2. Correction Factor(dB/m) = Antenna Factor (dB/m) + Cable Factor (dB)
3. The other emission levels were very low against the limit.
4. Margin value = Emission level – Limit value.



A D T

EUT TEST CONDITION		MEASUREMENT DETAIL	
SUB-BAND	1 + 2 + 3	FREQUENCY RANGE	Above 1GHz
MODULATION TECHNOLOGY	MOFDM	DETECTOR FUNCTION	Peak / Average
INPUT POWER (SYSTEM)	120Vac, 60 Hz	ENVIRONMENTAL CONDITIONS	25 deg. C, 65 %RH, 982hPa
TESTED BY	Dean Wang	TEST MODE	C

ANTENNA POLARITY & TEST DISTANCE: HORIZONTAL AT 1 M								
NO.	FREQ. (MHz)	EMISSION LEVEL (dBuV/m)	LIMIT (dBuV/m)	MARGIN (dB)	ANTENNA HEIGHT (m)	TABLE ANGLE (Degree)	RAW VALUE (dBuV)	CORRECTION FACTOR (dB/m)
1	1212.50	46.91 PK	83.54	-36.63	1.00 H	276	17.02	29.89
2	1212.50	42.45 AV	63.54	-21.09	1.00 H	276	12.56	29.89
3	1220.00	45.56 PK	83.54	-37.98	1.00 H	295	15.65	29.91
4	1220.00	33.34 AV	63.54	-30.20	1.00 H	295	3.43	29.91
5	1560.00	46.11 PK	83.54	-37.43	1.00 H	329	15.38	30.73
6	1560.00	32.06 AV	63.54	-31.48	1.00 H	329	1.33	30.73
7	1569.00	46.92 PK	83.54	-36.62	1.00 H	305	16.17	30.75
8	1569.00	40.08 AV	63.54	-23.46	1.00 H	305	9.33	30.75
9	1600.00	42.86 PK	83.54	-40.68	1.00 H	277	12.07	30.79
10	1600.00	32.12 AV	63.54	-31.42	1.00 H	277	1.33	30.79
ANTENNA POLARITY & TEST DISTANCE: VERTICAL AT 1 M								
NO.	FREQ. (MHz)	EMISSION LEVEL (dBuV/m)	LIMIT (dBuV/m)	MARGIN (dB)	ANTENNA HEIGHT (m)	TABLE ANGLE (Degree)	RAW VALUE (dBuV)	CORRECTION FACTOR (dB/m)
1	1212.50	49.23 PK	83.54	-34.31	1.00 V	272	19.34	29.89
2	1212.50	44.91 AV	63.54	-18.63	1.00 V	272	15.02	29.89
3	1220.00	43.18 PK	83.54	-40.36	1.00 V	266	13.27	29.91
4	1220.00	30.82 AV	63.54	-32.72	1.00 V	266	0.91	29.91
5	1560.00	47.36 PK	83.54	-36.18	1.00 V	245	16.63	30.73
6	1560.00	33.27 AV	63.54	-30.27	1.00 V	245	2.54	30.73
7	1569.00	45.79 PK	83.54	-37.75	1.00 V	311	15.04	30.75
8	1569.00	38.97 AV	63.54	-24.57	1.00 V	311	8.22	30.75
9	1600.00	46.38 PK	83.54	-37.16	1.00 V	215	15.59	30.79
10	1600.00	35.74 AV	63.54	-27.80	1.00 V	215	4.95	30.79

REMARKS:

1. Emission level(dBuV/m)=Raw Value(dBuV) + Correction Factor(dB/m)
2. Correction Factor(dB/m) = Antenna Factor (dB/m) + Cable Factor (dB)
3. The other emission levels were very low against the limit.
4. Margin value = Emission level – Limit value.



A D T

EUT TEST CONDITION		MEASUREMENT DETAIL	
SUB-BAND	1 + 2 + 3	FREQUENCY RANGE	Above 1GHz
MODULATION TECHNOLOGY	MOFDM	DETECTOR FUNCTION	Peak / Average
INPUT POWER (SYSTEM)	120Vac, 60 Hz	ENVIRONMENTAL CONDITIONS	25 deg. C, 65 %RH, 982hPa
TESTED BY	Dean Wang	TEST MODE	D

ANTENNA POLARITY & TEST DISTANCE: HORIZONTAL AT 1 M								
NO.	FREQ. (MHz)	EMISSION LEVEL (dBuV/m)	LIMIT (dBuV/m)	MARGIN (dB)	ANTENNA HEIGHT (m)	TABLE ANGLE (Degree)	RAW VALUE (dBuV)	CORRECTION FACTOR (dB/m)
1	1212.50	46.72 PK	83.54	-36.82	1.00 H	271	16.83	29.89
2	1212.50	42.26 AV	63.54	-21.28	1.00 H	271	12.37	29.89
3	1220.00	45.38 PK	83.54	-38.16	1.00 H	297	15.47	29.91
4	1220.00	33.15 AV	63.54	-30.39	1.00 H	297	3.24	29.91
5	1560.00	45.92 PK	83.54	-37.62	1.00 H	331	15.19	30.73
6	1560.00	31.87 AV	63.54	-31.67	1.00 H	331	1.14	30.73
7	1569.00	46.75 PK	83.54	-36.79	1.00 H	308	16	30.75
8	1569.00	39.92 AV	63.54	-23.62	1.00 H	308	9.17	30.75
9	1600.00	42.67 PK	83.54	-40.87	1.00 H	274	11.88	30.79
10	1600.00	31.93 AV	63.54	-31.61	1.00 H	274	1.14	30.79
ANTENNA POLARITY & TEST DISTANCE: VERTICAL AT 1 M								
NO.	FREQ. (MHz)	EMISSION LEVEL (dBuV/m)	LIMIT (dBuV/m)	MARGIN (dB)	ANTENNA HEIGHT (m)	TABLE ANGLE (Degree)	RAW VALUE (dBuV)	CORRECTION FACTOR (dB/m)
1	1212.50	49.05 PK	83.54	-34.49	1.00 V	271	19.16	29.89
2	1212.50	44.78 AV	63.54	-18.76	1.00 V	271	14.89	29.89
3	1220.00	43.02 PK	83.54	-40.52	1.00 V	263	13.11	29.91
4	1220.00	30.64 AV	63.54	-32.90	1.00 V	263	0.73	29.91
5	1560.00	47.15 PK	83.54	-36.39	1.00 V	249	16.42	30.73
6	1560.00	33.08 AV	63.54	-30.46	1.00 V	249	2.35	30.73
7	1569.00	45.61 PK	83.54	-37.93	1.00 V	316	14.86	30.75
8	1569.00	38.79 AV	63.54	-24.75	1.00 V	316	8.04	30.75
9	1600.00	46.15 PK	83.54	-37.39	1.00 V	219	15.36	30.79
10	1600.00	35.58 AV	63.54	-27.96	1.00 V	219	4.79	30.79

REMARKS:

1. Emission level(dBuV/m)=Raw Value(dBuV) + Correction Factor(dB/m)
2. Correction Factor(dB/m) = Antenna Factor (dB/m) + Cable Factor (dB)
3. The other emission levels were very low against the limit.
4. Margin value = Emission level – Limit value.



A D T

EUT TEST CONDITION		MEASUREMENT DETAIL	
SUB-BAND	1 + 2 + 3	FREQUENCY RANGE	Above 1GHz
MODULATION TECHNOLOGY	MOFDM	DETECTOR FUNCTION	Peak / Average
INPUT POWER (SYSTEM)	120Vac, 60 Hz	ENVIRONMENTAL CONDITIONS	25 deg. C, 65 %RH, 982hPa
TESTED BY	Dean Wang	TEST MODE	E

ANTENNA POLARITY & TEST DISTANCE: HORIZONTAL AT 1 M								
NO.	FREQ. (MHz)	EMISSION LEVEL (dBuV/m)	LIMIT (dBuV/m)	MARGIN (dB)	ANTENNA HEIGHT (m)	TABLE ANGLE (Degree)	RAW VALUE (dBuV)	CORRECTION FACTOR (dB/m)
1	1212.50	46.59 PK	83.54	-36.95	1.00 H	275	16.7	29.89
2	1212.50	42.14 AV	63.54	-21.40	1.00 H	275	12.25	29.89
3	1220.00	45.24 PK	83.54	-38.30	1.00 H	292	15.33	29.91
4	1220.00	33.03 AV	63.54	-30.51	1.00 H	292	3.12	29.91
5	1560.00	46.11 PK	83.54	-37.43	1.00 H	334	15.38	30.73
6	1560.00	32.02 AV	63.54	-31.52	1.00 H	334	1.29	30.73
7	1569.00	46.87 PK	83.54	-36.67	1.00 H	311	16.12	30.75
8	1569.00	40.05 AV	63.54	-23.49	1.00 H	311	9.3	30.75
9	1600.00	42.78 PK	83.54	-40.76	1.00 H	277	11.99	30.79
10	1600.00	32.01 AV	63.54	-31.53	1.00 H	277	1.22	30.79
ANTENNA POLARITY & TEST DISTANCE: VERTICAL AT 1 M								
NO.	FREQ. (MHz)	EMISSION LEVEL (dBuV/m)	LIMIT (dBuV/m)	MARGIN (dB)	ANTENNA HEIGHT (m)	TABLE ANGLE (Degree)	RAW VALUE (dBuV)	CORRECTION FACTOR (dB/m)
1	1212.50	48.87 PK	83.54	-34.67	1.00 V	273	18.98	29.89
2	1212.50	44.66 AV	63.54	-18.88	1.00 V	273	14.77	29.89
3	1220.00	42.93 PK	83.54	-40.61	1.00 V	265	13.02	29.91
4	1220.00	30.49 AV	63.54	-33.05	1.00 V	265	0.58	29.91
5	1560.00	47.32 PK	83.54	-36.22	1.00 V	256	16.59	30.73
6	1560.00	33.24 AV	63.54	-30.30	1.00 V	256	2.51	30.73
7	1569.00	45.73 PK	83.54	-37.81	1.00 V	322	14.98	30.75
8	1569.00	38.91 AV	63.54	-24.63	1.00 V	322	8.16	30.75
9	1600.00	46.31 PK	83.54	-37.23	1.00 V	223	15.52	30.79
10	1600.00	35.67 AV	63.54	-27.87	1.00 V	223	4.88	30.79

REMARKS:

1. Emission level(dBuV/m)=Raw Value(dBuV) + Correction Factor(dB/m)
2. Correction Factor(dB/m) = Antenna Factor (dB/m) + Cable Factor (dB)
3. The other emission levels were very low against the limit.
4. Margin value = Emission level – Limit value.



A D T

EUT TEST CONDITION		MEASUREMENT DETAIL	
SUB-BAND	1 + 2 + 3	FREQUENCY RANGE	Above 1GHz
MODULATION TECHNOLOGY	MOFDM	DETECTOR FUNCTION	Peak / Average
INPUT POWER (SYSTEM)	120Vac, 60 Hz	ENVIRONMENTAL CONDITIONS	25 deg. C, 65 %RH, 982hPa
TESTED BY	Dean Wang	TEST MODE	F

ANTENNA POLARITY & TEST DISTANCE: HORIZONTAL AT 1 M								
NO.	FREQ. (MHz)	EMISSION LEVEL (dBuV/m)	LIMIT (dBuV/m)	MARGIN (dB)	ANTENNA HEIGHT (m)	TABLE ANGLE (Degree)	RAW VALUE (dBuV)	CORRECTION FACTOR (dB/m)
1	1212.50	46.43 PK	83.54	-37.11	1.00 H	278	16.54	29.89
2	1212.50	42.03 AV	63.54	-21.51	1.00 H	278	12.14	29.89
3	1220.00	45.11 PK	83.54	-38.43	1.00 H	288	15.2	29.91
4	1220.00	32.89 AV	63.54	-30.65	1.00 H	288	2.98	29.91
5	1560.00	45.87 PK	83.54	-37.67	1.00 H	342	15.14	30.73
6	1560.00	31.84 AV	63.54	-31.70	1.00 H	342	1.11	30.73
7	1569.00	46.69 PK	83.54	-36.85	1.00 H	316	15.94	30.75
8	1569.00	39.87 AV	63.54	-23.67	1.00 H	316	9.12	30.75
9	1600.00	42.57 PK	83.54	-40.97	1.00 H	269	11.78	30.79
10	1600.00	31.83 AV	63.54	-31.71	1.00 H	269	1.04	30.79
ANTENNA POLARITY & TEST DISTANCE: VERTICAL AT 1 M								
NO.	FREQ. (MHz)	EMISSION LEVEL (dBuV/m)	LIMIT (dBuV/m)	MARGIN (dB)	ANTENNA HEIGHT (m)	TABLE ANGLE (Degree)	RAW VALUE (dBuV)	CORRECTION FACTOR (dB/m)
1	1212.50	48.69 PK	83.54	-34.85	1.00 V	277	18.8	29.89
2	1212.50	44.52 AV	63.54	-19.02	1.00 V	277	14.63	29.89
3	1220.00	42.76 PK	83.54	-40.78	1.00 V	268	12.85	29.91
4	1220.00	30.34 AV	63.54	-33.20	1.00 V	268	0.43	29.91
5	1560.00	47.16 PK	83.54	-36.38	1.00 V	258	16.43	30.73
6	1560.00	33.11 AV	63.54	-30.43	1.00 V	258	2.38	30.73
7	1569.00	45.56 PK	83.54	-37.98	1.00 V	323	14.81	30.75
8	1569.00	38.74 AV	63.54	-24.80	1.00 V	323	7.99	30.75
9	1600.00	46.17 PK	83.54	-37.37	1.00 V	235	15.38	30.79
10	1600.00	35.53 AV	63.54	-28.01	1.00 V	235	4.74	30.79

REMARKS:

1. Emission level(dBuV/m)=Raw Value(dBuV) + Correction Factor(dB/m)
2. Correction Factor(dB/m) = Antenna Factor (dB/m) + Cable Factor (dB)
3. The other emission levels were very low against the limit.
4. Margin value = Emission level – Limit value.



A D T

EUT TEST CONDITION		MEASUREMENT DETAIL	
SUB-BAND	1 + 2 + 3	FREQUENCY RANGE	Above 1GHz
MODULATION TECHNOLOGY	MOFDM	DETECTOR FUNCTION	Peak / Average
INPUT POWER (SYSTEM)	120Vac, 60 Hz	ENVIRONMENTAL CONDITIONS	25 deg. C, 65 %RH, 982hPa
TESTED BY	Dean Wang	TEST MODE	G

ANTENNA POLARITY & TEST DISTANCE: HORIZONTAL AT 1 M								
NO.	FREQ. (MHz)	EMISSION LEVEL (dBuV/m)	LIMIT (dBuV/m)	MARGIN (dB)	ANTENNA HEIGHT (m)	TABLE ANGLE (Degree)	RAW VALUE (dBuV)	CORRECTION FACTOR (dB/m)
1	1212.50	46.47 PK	83.54	-37.07	1.00 H	283	16.58	29.89
2	1212.50	42.02 AV	63.54	-21.52	1.00 H	283	12.13	29.89
3	1220.00	45.11 PK	83.54	-38.43	1.00 H	289	15.2	29.91
4	1220.00	32.94 AV	63.54	-30.60	1.00 H	289	3.03	29.91
5	1560.00	45.97 PK	83.54	-37.57	1.00 H	328	15.24	30.73
6	1560.00	31.86 AV	63.54	-31.68	1.00 H	328	1.13	30.73
7	1569.00	46.74 PK	83.54	-36.80	1.00 H	320	15.99	30.75
8	1569.00	39.92 AV	63.54	-23.62	1.00 H	320	9.17	30.75
9	1600.00	42.64 PK	83.54	-40.90	1.00 H	283	11.85	30.79
10	1600.00	31.84 AV	63.54	-31.70	1.00 H	283	1.05	30.79
ANTENNA POLARITY & TEST DISTANCE: VERTICAL AT 1 M								
NO.	FREQ. (MHz)	EMISSION LEVEL (dBuV/m)	LIMIT (dBuV/m)	MARGIN (dB)	ANTENNA HEIGHT (m)	TABLE ANGLE (Degree)	RAW VALUE (dBuV)	CORRECTION FACTOR (dB/m)
1	1212.50	48.76 PK	83.54	-34.78	1.00 V	277	18.87	29.89
2	1212.50	44.52 AV	63.54	-19.02	1.00 V	277	14.63	29.89
3	1220.00	42.78 PK	83.54	-40.76	1.00 V	269	12.87	29.91
4	1220.00	30.36 AV	63.54	-33.18	1.00 V	269	0.45	29.91
5	1560.00	47.21 PK	83.54	-36.33	1.00 V	261	16.48	30.73
6	1560.00	33.15 AV	63.54	-30.39	1.00 V	261	2.42	30.73
7	1569.00	45.59 PK	83.54	-37.95	1.00 V	331	14.84	30.75
8	1569.00	38.78 AV	63.54	-24.76	1.00 V	331	8.03	30.75
9	1600.00	46.17 PK	83.54	-37.37	1.00 V	235	15.38	30.79
10	1600.00	35.54 AV	63.54	-28.00	1.00 V	235	4.75	30.79

REMARKS:

1. Emission level(dBuV/m)=Raw Value(dBuV) + Correction Factor(dB/m)
2. Correction Factor(dB/m) = Antenna Factor (dB/m) + Cable Factor (dB)
3. The other emission levels were very low against the limit.
4. Margin value = Emission level – Limit value.



A D T

EUT TEST CONDITION		MEASUREMENT DETAIL	
SUB-BAND	1 + 2 + 3	FREQUENCY RANGE	Above 1GHz
MODULATION TECHNOLOGY	MOFDM	DETECTOR FUNCTION	Peak / Average
INPUT POWER (SYSTEM)	120Vac, 60 Hz	ENVIRONMENTAL CONDITIONS	25 deg. C, 65 %RH, 982hPa
TESTED BY	Dean Wang	TEST MODE	H

ANTENNA POLARITY & TEST DISTANCE: HORIZONTAL AT 1 M								
NO.	FREQ. (MHz)	EMISSION LEVEL (dBuV/m)	LIMIT (dBuV/m)	MARGIN (dB)	ANTENNA HEIGHT (m)	TABLE ANGLE (Degree)	RAW VALUE (dBuV)	CORRECTION FACTOR (dB/m)
1	1212.50	46.32 PK	83.54	-37.22	1.00 H	282	16.43	29.89
2	1212.50	41.94 AV	63.54	-21.60	1.00 H	282	12.05	29.89
3	1220.00	44.99 PK	83.54	-38.55	1.00 H	286	15.08	29.91
4	1220.00	32.78 AV	63.54	-30.76	1.00 H	286	2.87	29.91
5	1560.00	45.79 PK	83.54	-37.75	1.00 H	339	15.06	30.73
6	1560.00	31.72 AV	63.54	-31.82	1.00 H	339	0.99	30.73
7	1569.00	46.62 PK	83.54	-36.92	1.00 H	321	15.87	30.75
8	1569.00	39.79 AV	63.54	-23.75	1.00 H	321	9.04	30.75
9	1600.00	42.73 PK	83.54	-40.81	1.00 H	274	11.94	30.79
10	1600.00	31.97 AV	63.54	-31.57	1.00 H	274	1.18	30.79
ANTENNA POLARITY & TEST DISTANCE: VERTICAL AT 1 M								
NO.	FREQ. (MHz)	EMISSION LEVEL (dBuV/m)	LIMIT (dBuV/m)	MARGIN (dB)	ANTENNA HEIGHT (m)	TABLE ANGLE (Degree)	RAW VALUE (dBuV)	CORRECTION FACTOR (dB/m)
1	1212.50	48.57 PK	83.54	-34.97	1.00 V	269	18.68	29.89
2	1212.50	44.38 AV	63.54	-19.16	1.00 V	269	14.49	29.89
3	1220.00	42.62 PK	83.54	-40.92	1.00 V	262	12.71	29.91
4	1220.00	30.21 AV	63.54	-33.33	1.00 V	262	0.3	29.91
5	1560.00	47.28 PK	83.54	-36.26	1.00 V	261	16.55	30.73
6	1560.00	33.24 AV	63.54	-30.30	1.00 V	261	2.51	30.73
7	1569.00	45.67 PK	83.54	-37.87	1.00 V	319	14.92	30.75
8	1569.00	38.89 AV	63.54	-24.65	1.00 V	319	8.14	30.75
9	1600.00	46.08 PK	83.54	-37.46	1.00 V	231	15.29	30.79
10	1600.00	35.42 AV	63.54	-28.12	1.00 V	231	4.63	30.79

REMARKS:

1. Emission level(dBuV/m)=Raw Value(dBuV) + Correction Factor(dB/m)
2. Correction Factor(dB/m) = Antenna Factor (dB/m) + Cable Factor (dB)
3. The other emission levels were very low against the limit.
4. Margin value = Emission level – Limit value.

BAND GROUP 1, WITHOUT METAL SHIELDING CASE ON REAR SIDE

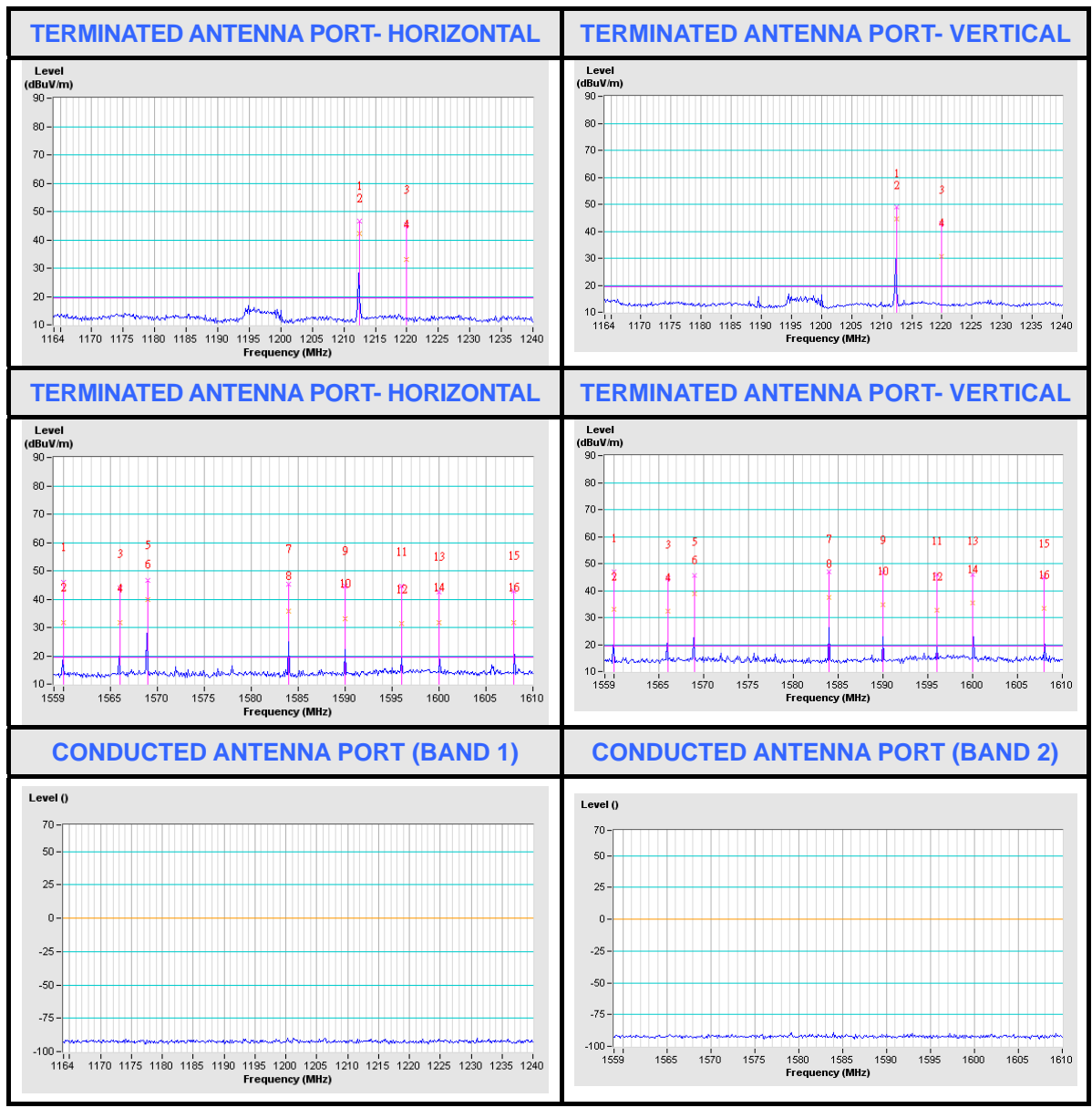

BAND GROUP 3, WITHOUT METAL SHIELDING CASE ON REAR SIDE

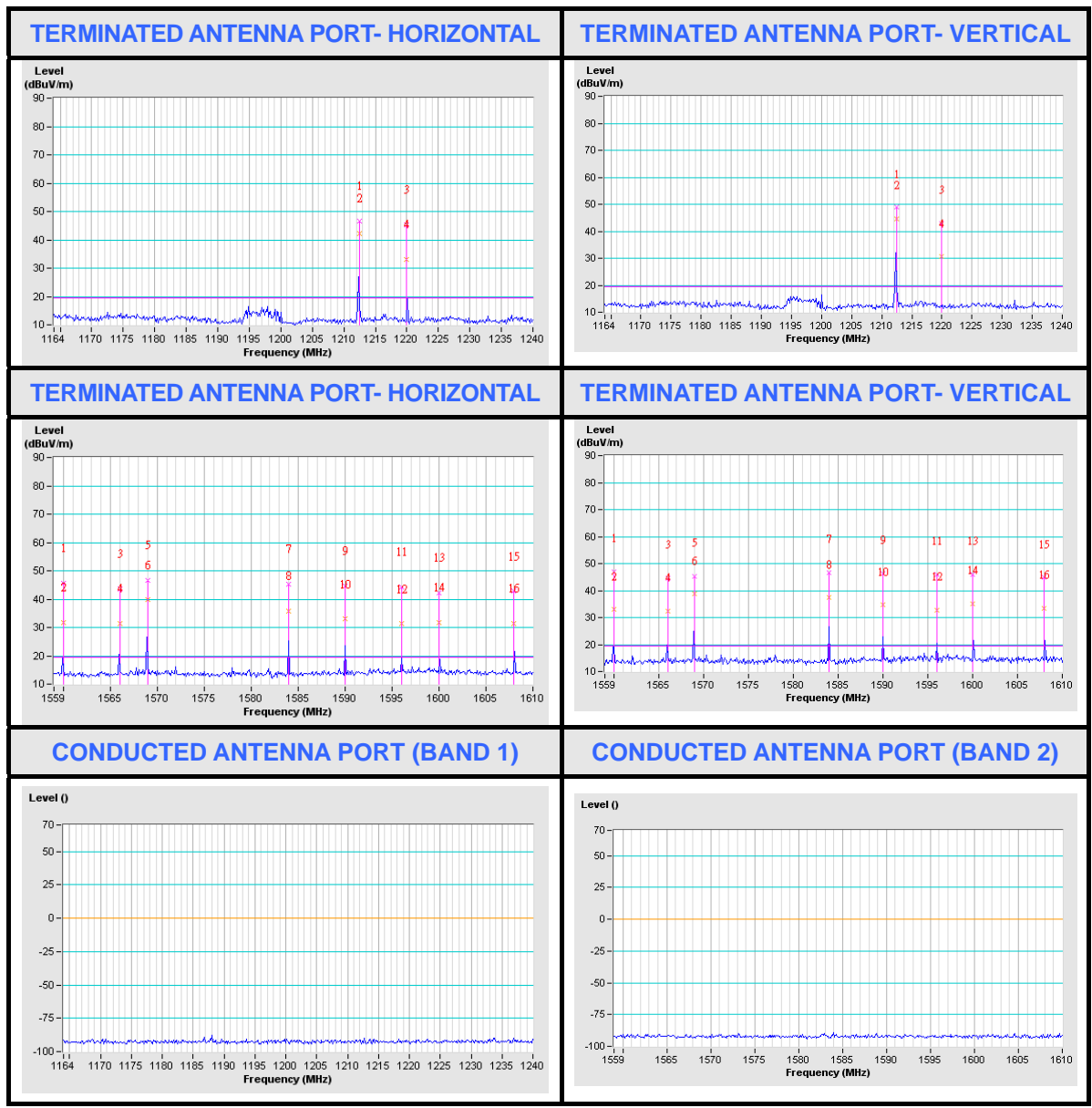

BAND GROUP 1, WITH METAL SHIELDING CASE ON REAR SIDE

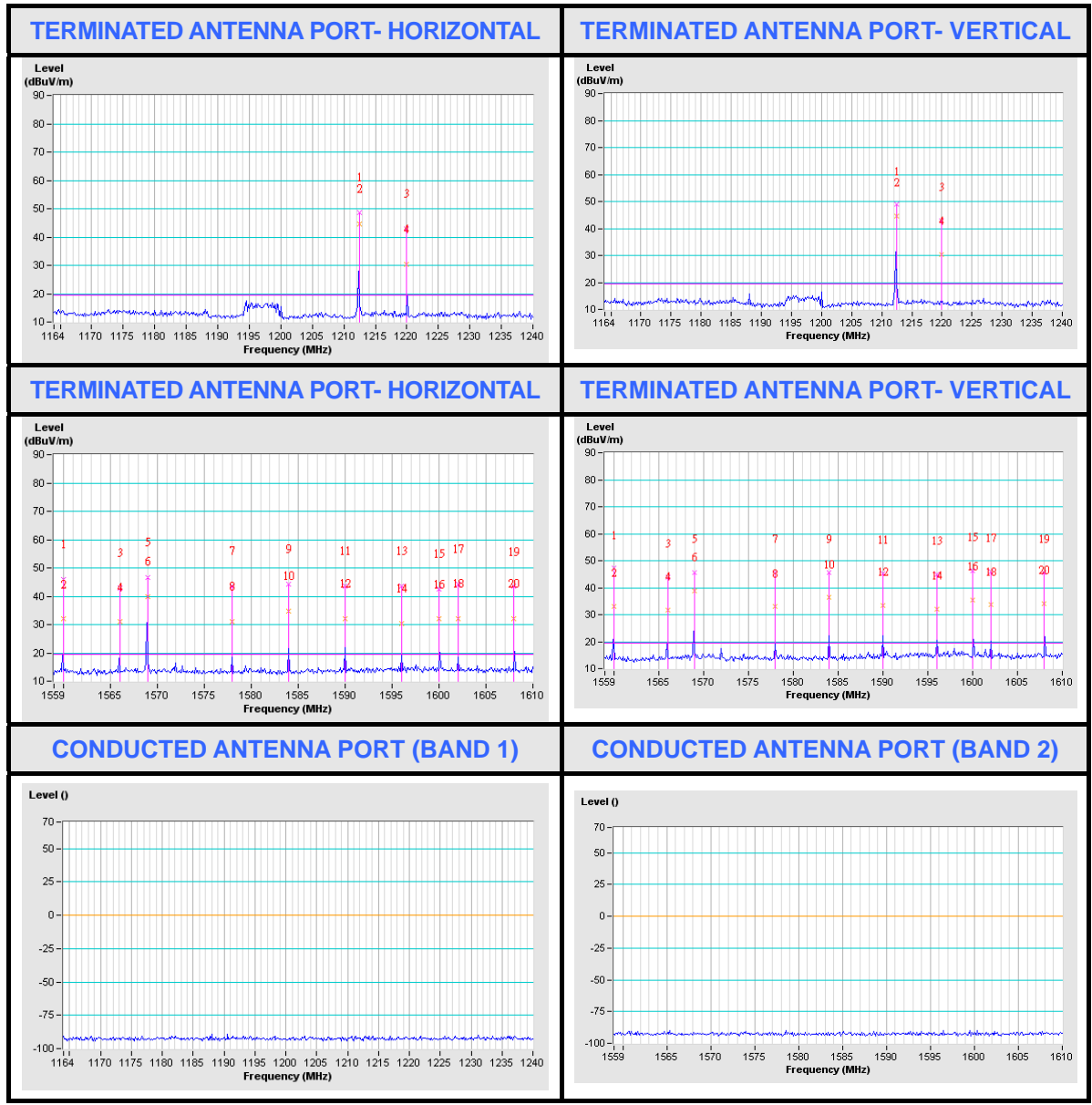

BAND GROUP 3, WITH METAL SHIELDING CASE ON REAR SIDE

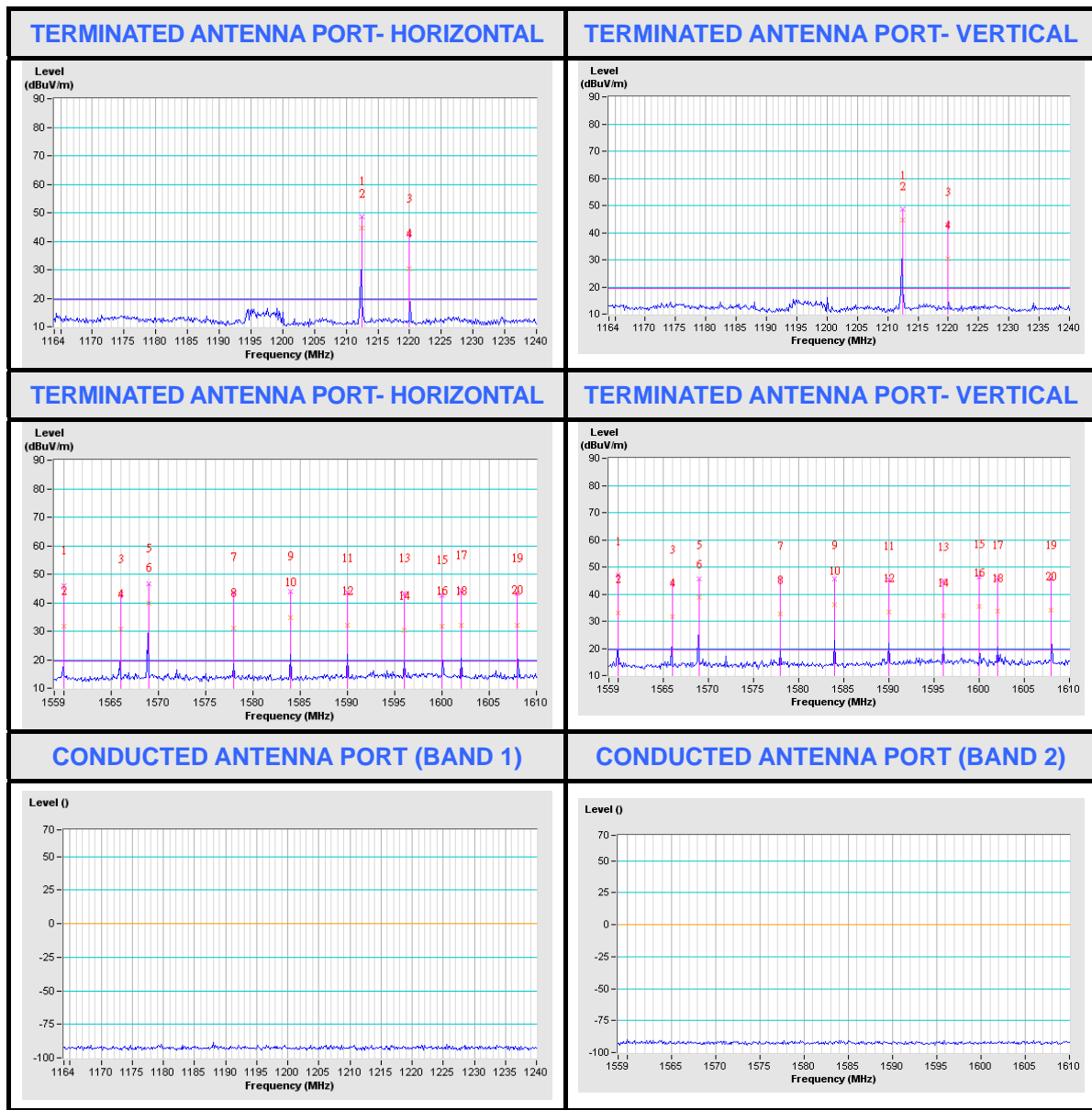



4.4 UWB BANDWIDTH MEASUREMENT

4.4.1 LIMITS OF UWB BANDWIDTH MEASUREMENT

The UWB bandwidth of a UWB system operating under the provisions of this section must be contained between 3100MHz and 10,600MHz.

4.4.2 INSTRUMENT SETUP VALUE AND MEASUREMENT DISTANCE

FREQUENCY RANGE	RESOLUTION BANDWIDTH	VIDEO BANDWIDTH	DETECTOR	MEASUREMENT DISTANCE
3,100 ~ 10,600	10MHz	10MHz	Peak	3 meters

4.4.3 TEST INSTRUMENT

Same as Item 4.2.3

4.4.4 TEST PROCEDURE

- The EUT was placed on the top of a rotating table 0.8 meters above the ground at a 3 meters semi-anechoic chamber. The table was rotated 360 degrees to determine the position of the highest radiation.
- The EUT was set 3 meters away from the interference-receiving antenna, which was mounted on the top of a variable-height antenna tower.
- The antenna is a broadband antenna, and its height is varied from one meter to four meters above the ground to determine the maximum value of the field strength. Both horizontal and vertical polarizations of the antenna are set to make the measurement.
- For each suspected emission, the EUT was arranged to its worst case and then the antenna was tuned to heights from 1 meter to 4 meters and the rotatable table was turned from 0 degrees to 360 degrees to find the maximum reading.
- The Spectrum Analyzer system was set to Peak Detect Function and Specified Bandwidth with Maximum Hold Mode.
- The UWB Bandwidth is measured at the 10dB point (F_L , F_H).



A D T

4.4.5 DEVIATION FROM TEST STANDARD

No deviation

4.4.6 TEST SETUP

Same as Item 4.2.6

4.4.7 EUT OPERATING CONDITIONS

The software provided by client to enable the EUT under transmission condition continuously.



A D T

4.4.8 TEST RESULTS

SUB-BAND	1 + 2 + 3	INPUT POWER (SYSTEM)	120Vac, 60 Hz
MODULATION TECHNOLOGY	MOFDM	ENVIRONMENTAL CONDITIONS	24 deg.C, 64 %RH, 991hPa
TESTED BY	Dean Wang	TEST MODE	A

F_L (MHz)	F_H (MHz)	$F_C=(F_L+F_H)/2$ (MHz)	LIMIT (MHz)	PASS/FAIL
3172.00	4744.00	3958.00	Between 3100.00 ~ 10600.00	PASS

UWB Bandwidth = $F_H - F_L = 1572\text{MHz}$

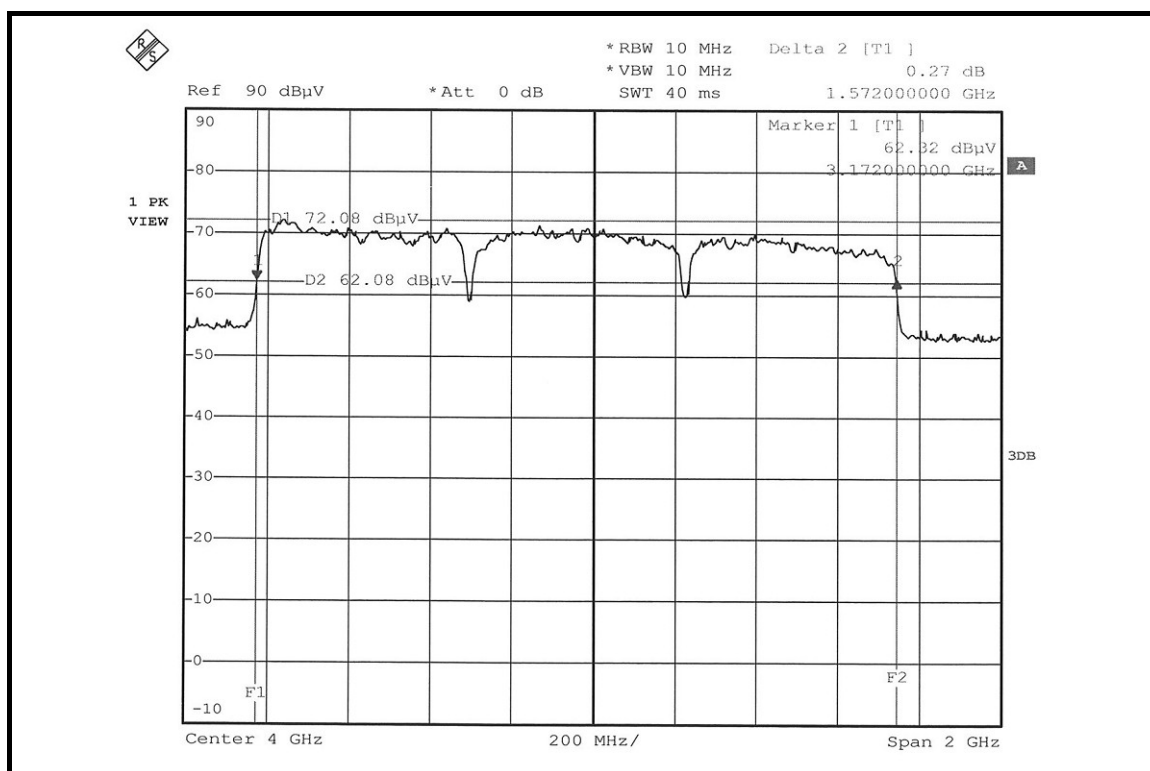



A D T

SUB-BAND	1 + 2 + 3	INPUT POWER (SYSTEM)	120Vac, 60 Hz
MODULATION TECHNOLOGY	MOFDM	ENVIRONMENTAL CONDITIONS	24 deg.C, 64 %RH, 991hPa
TESTED BY	Dean Wang	TEST MODE	B

F_L (MHz)	F_H (MHz)	F_C=(F_L+F_H)/2 (MHz)	LIMIT (MHz)	PASS/FAIL
6328.00	7908.00	7118.00	Between 3100.00 ~ 10600.00	PASS

UWB Bandwidth = F_H - F_L = 1580MHz

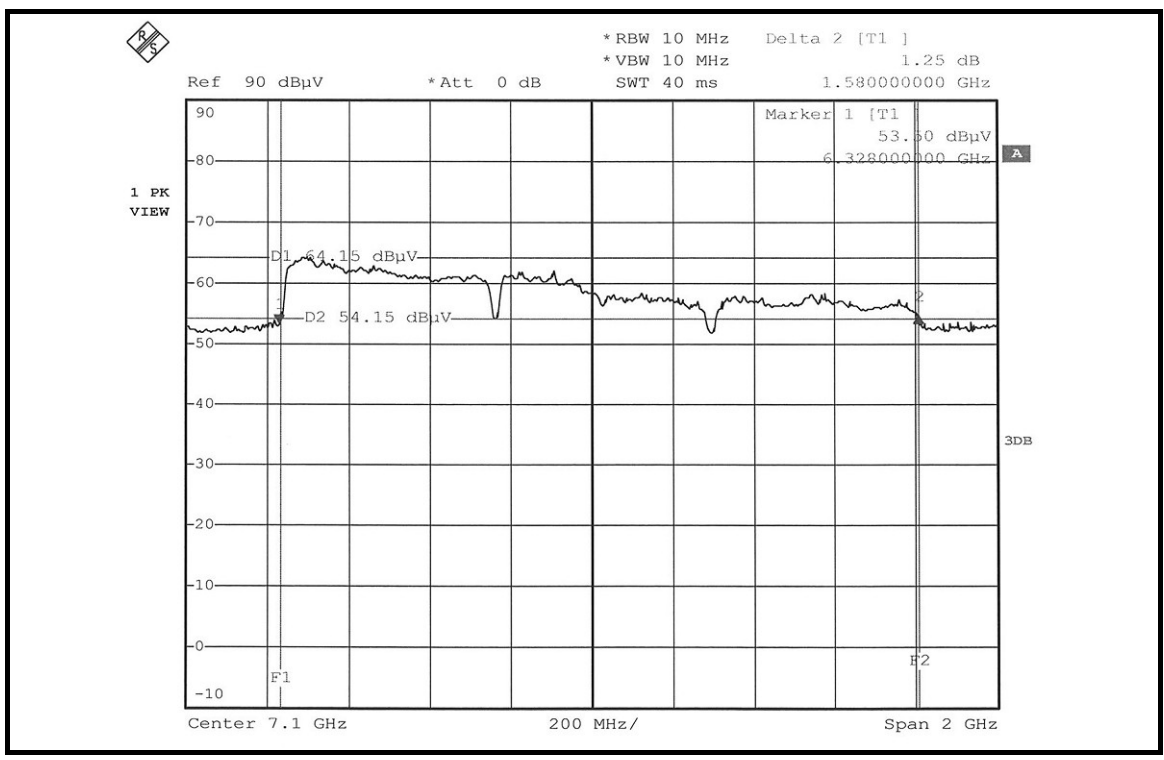



A D T

SUB-BAND	1 + 2 + 3	INPUT POWER (SYSTEM)	120Vac, 60 Hz
MODULATION TECHNOLOGY	MOFDM	ENVIRONMENTAL CONDITIONS	24 deg.C, 64 %RH, 991hPa
TESTED BY	Dean Wang	TEST MODE	C

F_L (MHz)	F_H (MHz)	F_C=(F_L+F_H)/2 (MHz)	LIMIT (MHz)	PASS/FAIL
3172.00	4740.00	3956.00	Between 3100.00 ~ 10600.00	PASS

UWB Bandwidth = $F_H - F_L = 1568\text{MHz}$

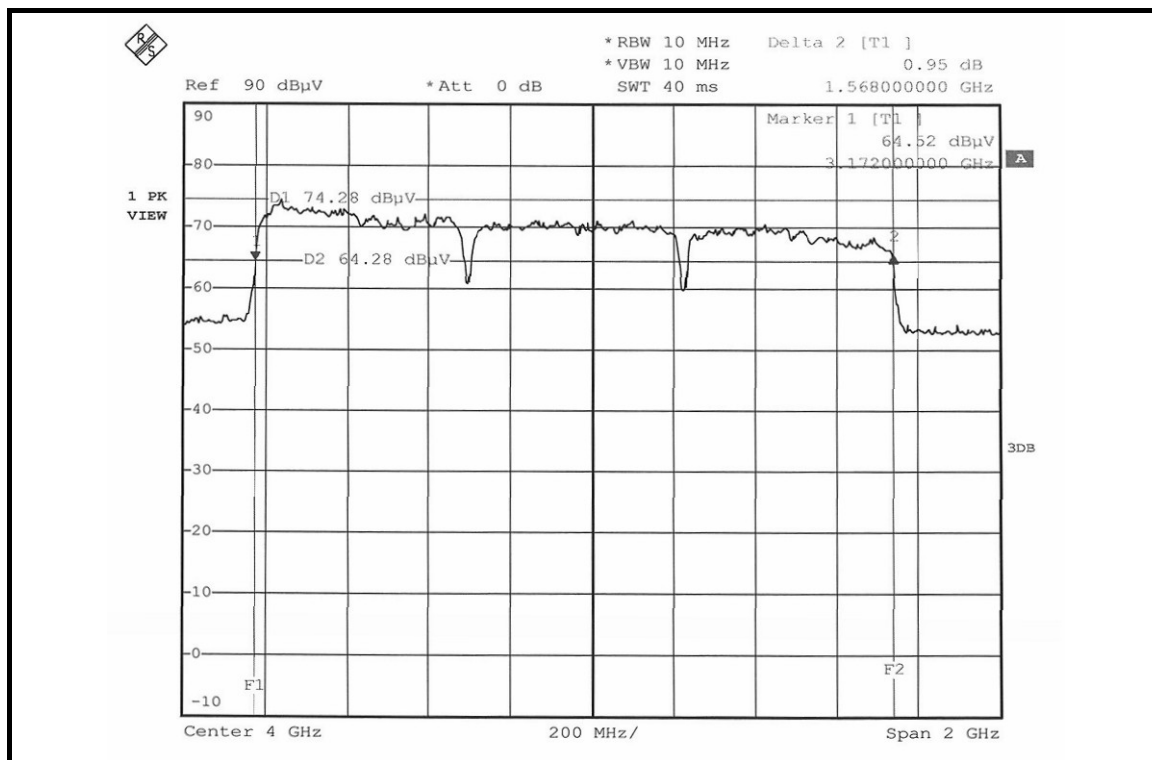



A D T

SUB-BAND	1 + 2 + 3	INPUT POWER (SYSTEM)	120Vac, 60 Hz
MODULATION TECHNOLOGY	MOFDM	ENVIRONMENTAL CONDITIONS	24 deg.C, 64 %RH, 991hPa
TESTED BY	Dean Wang	TEST MODE	D

F_L (MHz)	F_H (MHz)	F_C=(F_L+F_H)/2 (MHz)	LIMIT (MHz)	PASS/FAIL
6332.00	7912.00	7122.00	Between 3100.00 ~ 10600.00	PASS

UWB Bandwidth = F_H - F_L = 1580MHz

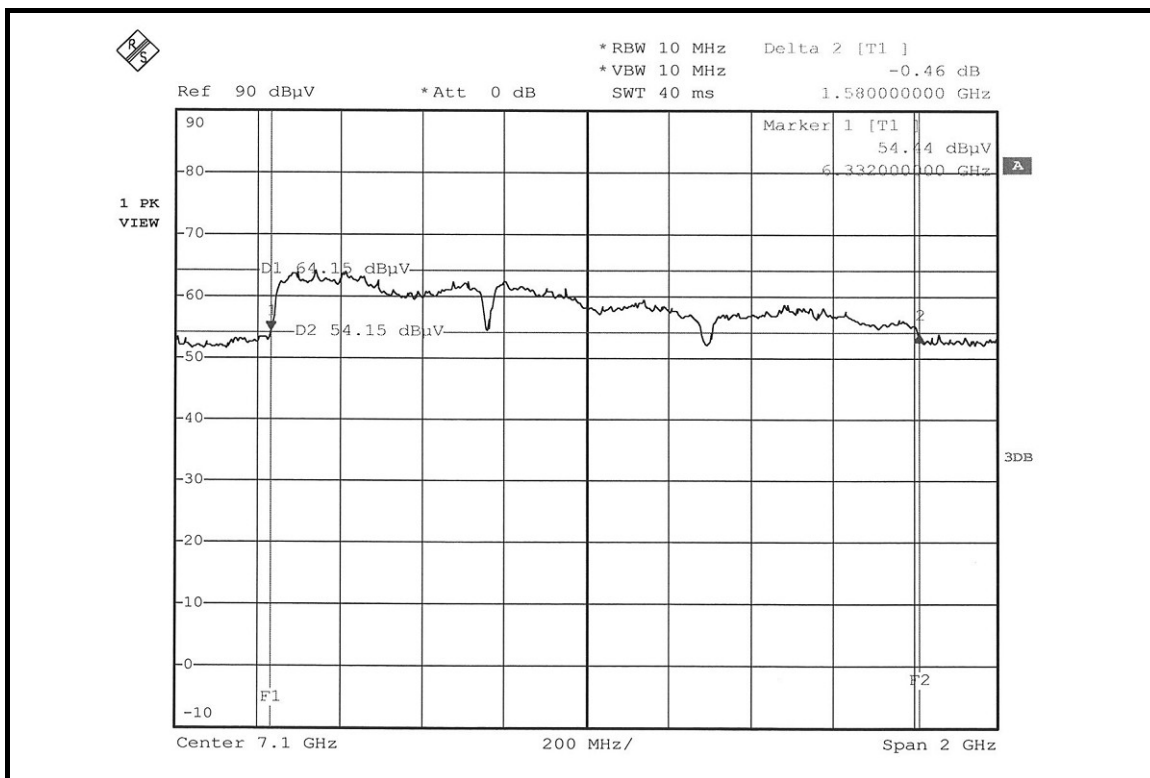



A D T

SUB-BAND	1 + 2 + 3	INPUT POWER (SYSTEM)	120Vac, 60 Hz
MODULATION TECHNOLOGY	MOFDM	ENVIRONMENTAL CONDITIONS	24 deg.C, 64 %RH, 991hPa
TESTED BY	Dean Wang	TEST MODE	E

F_L (MHz)	F_H (MHz)	$F_C=(F_L+F_H)/2$ (MHz)	LIMIT (MHz)	PASS/FAIL
3172.00	4744.00	3958.00	Between 3100.00 ~ 10600.00	PASS

UWB Bandwidth = $F_H - F_L = 1572\text{MHz}$

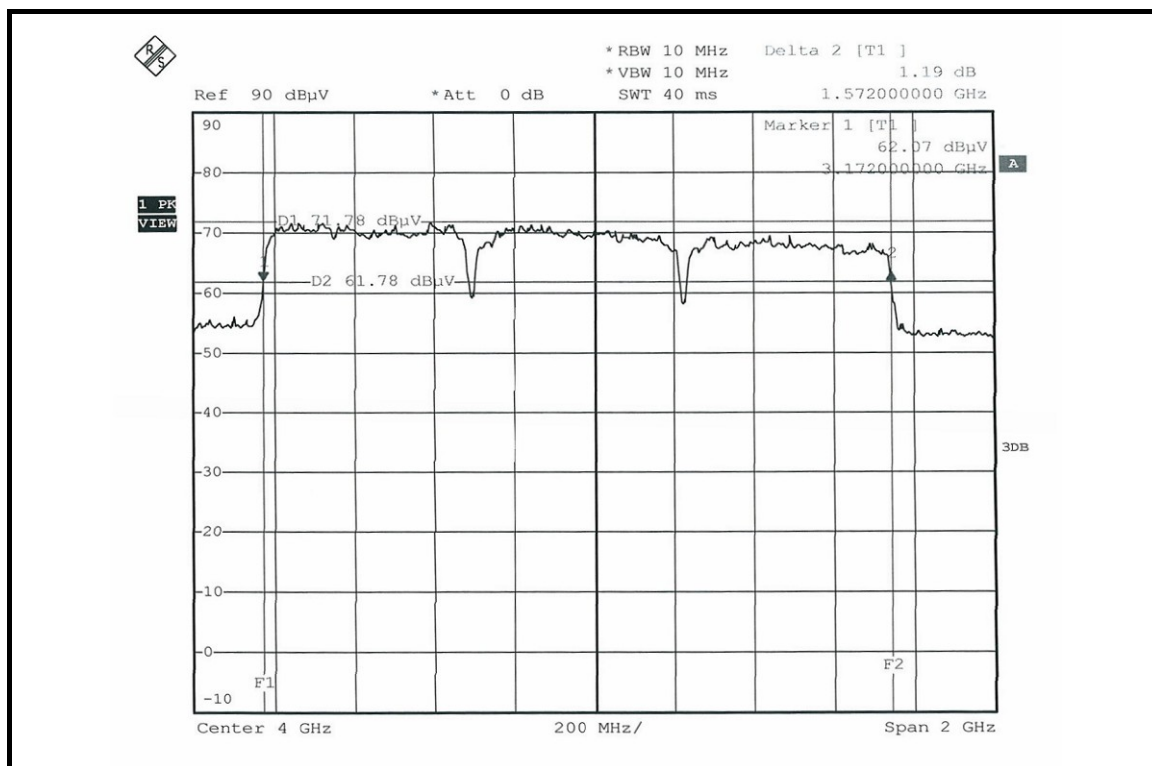



A D T

SUB-BAND	1 + 2 + 3	INPUT POWER (SYSTEM)	120Vac, 60 Hz
MODULATION TECHNOLOGY	MOFDM	ENVIRONMENTAL CONDITIONS	24 deg.C, 64 %RH, 991hPa
TESTED BY	Dean Wang	TEST MODE	F

F_L (MHz)	F_H (MHz)	F_C=(F_L+F_H)/2 (MHz)	LIMIT (MHz)	PASS/FAIL
6336.00	7900.00	7118.00	Between 3100.00 ~ 10600.00	PASS

UWB Bandwidth = F_H - F_L = 1564MHz

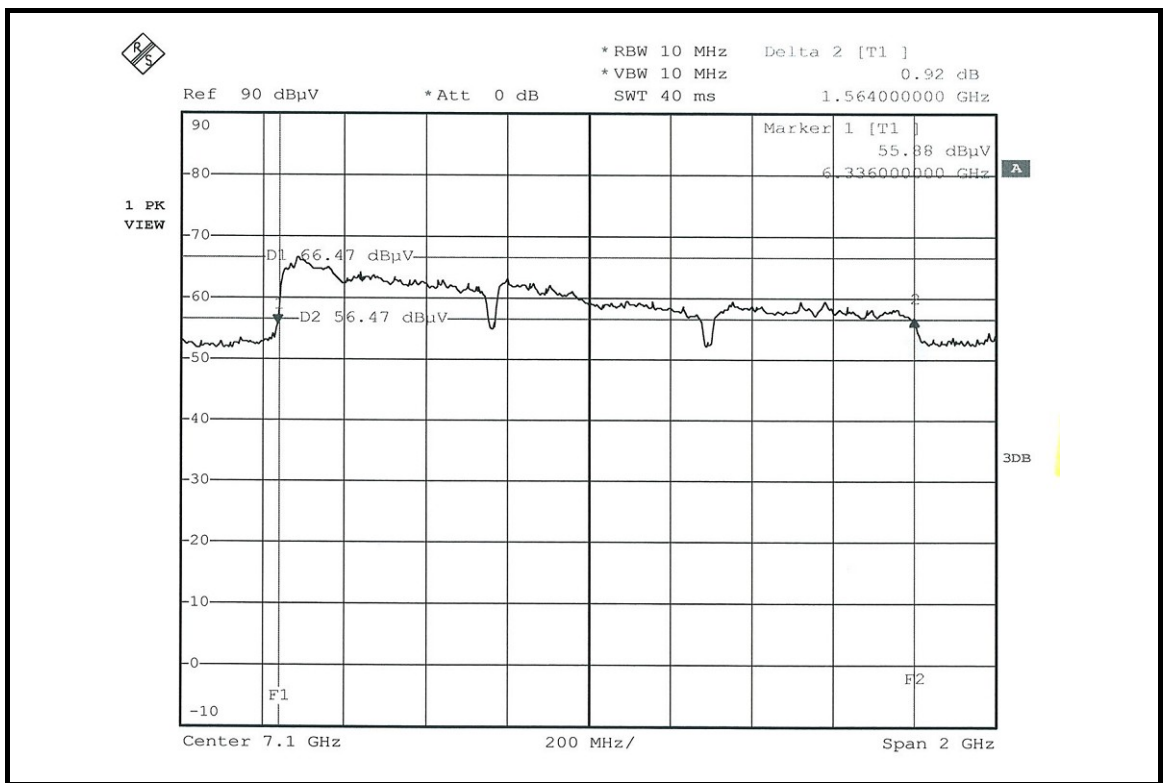



A D T

SUB-BAND	1 + 2 + 3	INPUT POWER (SYSTEM)	120Vac, 60 Hz
MODULATION TECHNOLOGY	MOFDM	ENVIRONMENTAL CONDITIONS	24 deg.C, 64 %RH, 991hPa
TESTED BY	Dean Wang	TEST MODE	G

F_L (MHz)	F_H (MHz)	F_C=(F_L+F_H)/2 (MHz)	LIMIT (MHz)	PASS/FAIL
3172.00	4740.00	3956.00	Between 3100.00 ~ 10600.00	PASS

UWB Bandwidth = $F_H - F_L = 1568\text{MHz}$

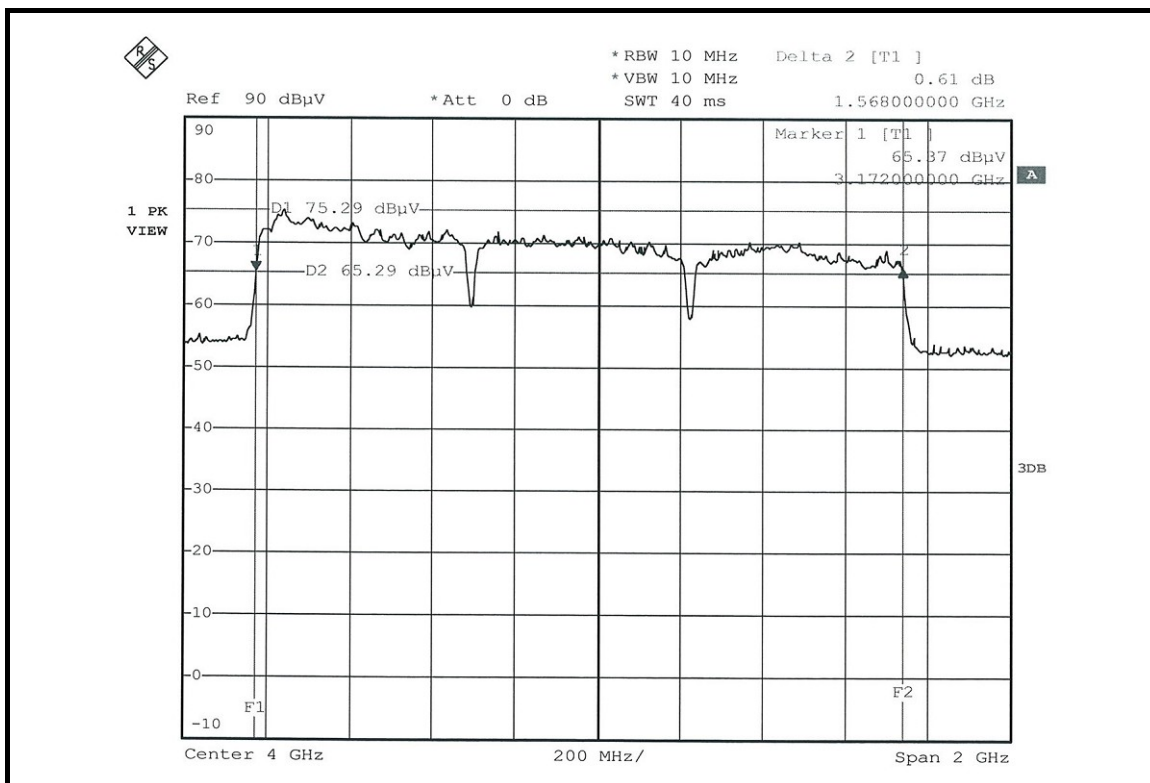



A D T

SUB-BAND	1 + 2 + 3	INPUT POWER (SYSTEM)	120Vac, 60 Hz
MODULATION TECHNOLOGY	MOFDM	ENVIRONMENTAL CONDITIONS	24 deg.C, 64 %RH, 991hPa
TESTED BY	Dean Wang	TEST MODE	F

F_L (MHz)	F_H (MHz)	F_C=(F_L+F_H)/2 (MHz)	LIMIT (MHz)	PASS/FAIL
6332.00	7880.00	7106.00	Between 3100.00 ~ 10600.00	PASS

UWB Bandwidth = F_H - F_L = 1548MHz

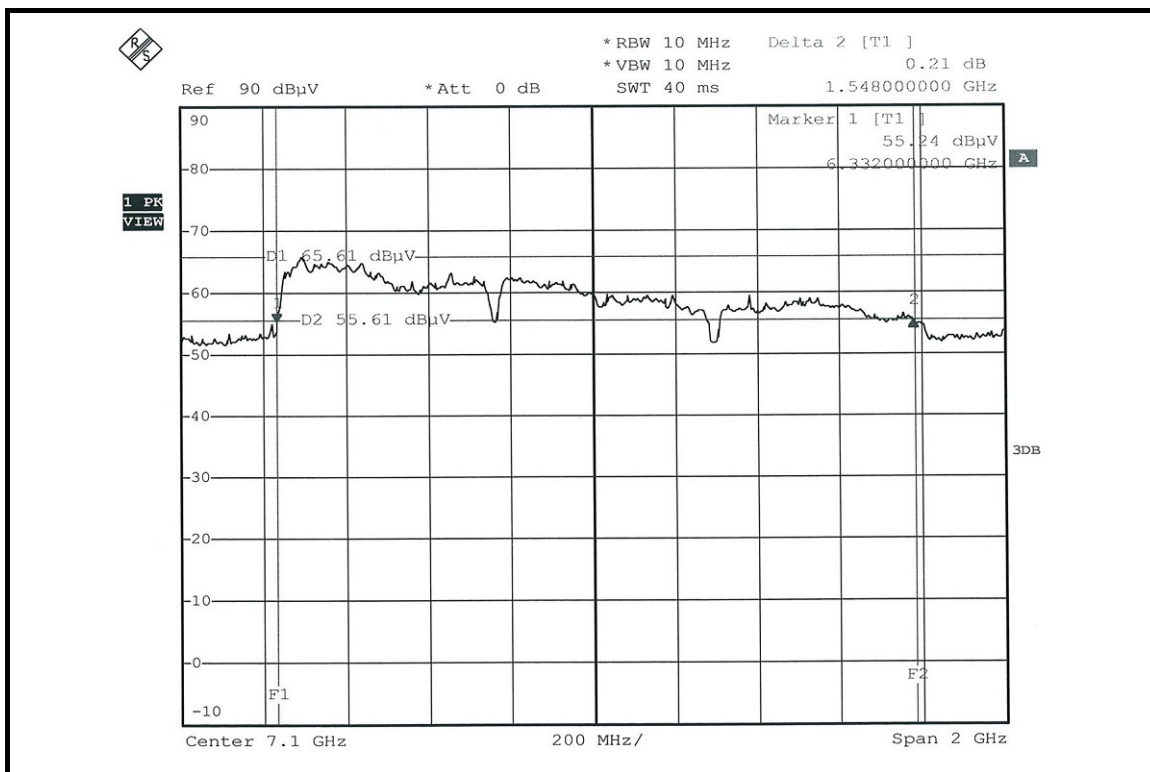



4.5 PEAK EMISSION WITHIN A 50MHz BANDWIDTH

4.5.1 LIMITS OF PEAK EMISSION

The peak emission measurement is acceptable to use the resolution bandwidth other than the 50MHz, which is indicated in 47CFR Part 15, Subpart F. The resolution bandwidth was set to 10MHz in this measurement. It has been determined to have an actual impulse response bandwidth of 9.4MHz (3dBcBW). Therefore the limit should be reduced $20\text{Log}(9.4 / 50)$. The video bandwidth was also set to 10MHz. And the measurement was centered on the frequency at which the highest radiated emission occurred.

The Maximum Peak Output Power Measurement is 0dBm(RBW=50MHz)

If a resolution bandwidth other than 50 MHz is Employed, the peak EIRP limit shall be $20 \log (RBW/50)$ dBm where RBW is the resolution bandwidth in megahertz that is employed. The resolution bandwidth used to make the peak measurement was 9.4 MHz, resulting in a limit of -14.52dBm.

This may be converted to a peak field strength level at 3 meters using $E(\text{dBuV/m}) = P(\text{dBm EIRP}) + 95.20 = -14.52 + 95.20 = 80.68$.

4.5.2 INSTRUMENT SETUP VALUE AND MEASUREMENT DISTANCE

RADIATED EMISSIONS 15.519 (e):

FREQUENCY RANGE	RESOLUTION BANDWIDTH	VIDEO BANDWIDTH	DETECTOR	MEASUREMENT DISTANCE
3,100 ~ 10,600	10MHz	10MHz	*Peak	3 meters

NOTE: *reference The Evolution of Modern UWB Technology



A D T

4.5.3 TEST INSTRUMENTS

Same as 4.2.3.

4.5.4 TEST PROCEDURE

Same as 4.2.4.

4.5.5 DEVIATION FROM TEST STANDARD

No deviation.

4.5.6 TEST SETUP

Same as Item 4.2.6.

4.5.7 EUT OPERATING CONDITIONS

Same as 4.1.6.



A D T

4.5.8 TEST RESULTS

MODULATION TECHNOLOGY	MOFDM	ENVIRONMENTAL CONDITIONS	25 deg. C, 65 %RH, 981hPa
INPUT POWER (SYSTEM)	120Vac, 60 Hz	TESTED BY	Dean Wang
TEST MODE	A		

ANTENNA POLARITY & TEST DISTANCE AT 3 M (HORIZONTAL)								
NO.	FREQ. (MHz)	EMISSION LEVEL (dBuV/m)	LIMIT (dBuV/m)	MARGIN (dB)	ANTENNA HEIGHT (m)	TABLE ANGLE (Degree)	RAW VALUE (dBuV)	CORRECTION FACTOR (dB/m)
1	3268.00	72.25 PK	80.68	-8.43	1.33 H	204	37.53	34.72
2	3824.00	69.93 PK	80.68	-10.75	1.33 H	204	34.14	35.79
3	4468.00	69.75 PK	80.68	-10.93	1.33 H	204	32.22	37.53
ANTENNA POLARITY & TEST DISTANCE AT 3 M (VERTICAL)								
NO.	FREQ. (MHz)	EMISSION LEVEL (dBuV/m)	LIMIT (dBuV/m)	MARGIN (dB)	ANTENNA HEIGHT (m)	TABLE ANGLE (Degree)	RAW VALUE (dBuV)	CORRECTION FACTOR (dB/m)
1	3236.00	73.22 PK	80.68	-7.46	1.00 V	126	38.53	34.69
2	3868.00	73.61 PK	80.68	-7.07	1.00 V	126	37.68	35.93
3	4396.00	73.81 PK	80.68	-6.87	1.00 V	126	36.55	37.26

MODULATION TECHNOLOGY	MOFDM	ENVIRONMENTAL CONDITIONS	25 deg. C, 65 %RH, 981hPa
INPUT POWER (SYSTEM)	120Vac, 60 Hz	TESTED BY	Dean Wang
TEST MODE	B		

ANTENNA POLARITY & TEST DISTANCE AT 3 M (HORIZONTAL)								
NO.	FREQ. (MHz)	EMISSION LEVEL (dBuV/m)	LIMIT (dBuV/m)	MARGIN (dB)	ANTENNA HEIGHT (m)	TABLE ANGLE (Degree)	RAW VALUE (dBuV)	CORRECTION FACTOR (dB/m)
1	6396.00	68.42 PK	80.68	-12.26	1.45 H	160	26.71	41.71
2	7052.00	68.24 PK	80.68	-12.44	1.45 H	160	24.45	43.79
3	7648.00	67.97 PK	80.68	-12.71	1.45 H	160	22.72	45.25
ANTENNA POLARITY & TEST DISTANCE AT 3 M (VERTICAL)								
NO.	FREQ. (MHz)	EMISSION LEVEL (dBuV/m)	LIMIT (dBuV/m)	MARGIN (dB)	ANTENNA HEIGHT (m)	TABLE ANGLE (Degree)	RAW VALUE (dBuV)	CORRECTION FACTOR (dB/m)
1	6384.00	72.63 PK	80.68	-8.05	1.00 V	124	30.95	41.68
2	7008.00	72.23 PK	80.68	-8.45	1.00 V	124	28.52	43.71
3	7676.00	70.14 PK	80.68	-10.54	1.00 V	124	24.88	45.26



A D T

MODULATION TECHNOLOGY	MOFDM	ENVIRONMENTAL CONDITIONS	25 deg. C, 65 %RH, 981hPa
INPUT POWER (SYSTEM)	120Vac, 60 Hz	TESTED BY	Dean Wang
TEST MODE	C		

ANTENNA POLARITY & TEST DISTANCE AT 3 M (HORIZONTAL)								
NO.	FREQ. (MHz)	EMISSION LEVEL (dBuV/m)	LIMIT (dBuV/m)	MARGIN (dB)	ANTENNA HEIGHT (m)	TABLE ANGLE (Degree)	RAW VALUE (dBuV)	CORRECTION FACTOR (dB/m)
1	3380.00	66.44 PK	80.68	-14.24	1.25 H	220	31.67	34.77
2	3928.00	67.17 PK	80.68	-13.51	1.25 H	220	31.10	36.07
3	4304.00	68.84 PK	80.68	-11.84	1.25 H	220	31.82	37.02

ANTENNA POLARITY & TEST DISTANCE AT 3 M (VERTICAL)								
NO.	FREQ. (MHz)	EMISSION LEVEL (dBuV/m)	LIMIT (dBuV/m)	MARGIN (dB)	ANTENNA HEIGHT (m)	TABLE ANGLE (Degree)	RAW VALUE (dBuV)	CORRECTION FACTOR (dB/m)
1	3236.00	75.42 PK	80.68	-5.26	1.01 V	205	40.73	34.69
2	4100.00	74.44 PK	80.68	-6.24	1.01 V	205	37.72	36.72
3	4424.00	74.63 PK	80.68	-6.05	1.01 V	205	37.27	37.36

MODULATION TECHNOLOGY	MOFDM	ENVIRONMENTAL CONDITIONS	25 deg. C, 65 %RH, 981hPa
INPUT POWER (SYSTEM)	120Vac, 60 Hz	TESTED BY	Dean Wang
TEST MODE	D		

ANTENNA POLARITY & TEST DISTANCE AT 3 M (HORIZONTAL)								
NO.	FREQ. (MHz)	EMISSION LEVEL (dBuV/m)	LIMIT (dBuV/m)	MARGIN (dB)	ANTENNA HEIGHT (m)	TABLE ANGLE (Degree)	RAW VALUE (dBuV)	CORRECTION FACTOR (dB/m)
1	6540.00	66.20 PK	80.68	-14.48	1.60 H	310	24.01	42.19
2	6932.00	67.55 PK	80.68	-13.13	1.60 H	310	24.03	43.52
3	7592.00	66.96 PK	80.68	-13.72	1.60 H	310	21.75	45.21

ANTENNA POLARITY & TEST DISTANCE AT 3 M (VERTICAL)								
NO.	FREQ. (MHz)	EMISSION LEVEL (dBuV/m)	LIMIT (dBuV/m)	MARGIN (dB)	ANTENNA HEIGHT (m)	TABLE ANGLE (Degree)	RAW VALUE (dBuV)	CORRECTION FACTOR (dB/m)
1	6440.00	72.79 PK	80.68	-7.89	1.35 V	260	30.95	41.84
2	6900.00	72.33 PK	80.68	-8.35	1.35 V	260	28.90	43.43
3	7588.00	70.37 PK	80.68	-10.31	1.35 V	260	25.17	45.20



A D T

MODULATION TECHNOLOGY	MOFDM	ENVIRONMENTAL CONDITIONS	25 deg. C, 65 %RH, 981hPa
INPUT POWER (SYSTEM)	120Vac, 60 Hz	TESTED BY	Dean Wang
TEST MODE	E		

ANTENNA POLARITY & TEST DISTANCE AT 3 M (HORIZONTAL)								
NO.	FREQ. (MHz)	EMISSION LEVEL (dBuV/m)	LIMIT (dBuV/m)	MARGIN (dB)	ANTENNA HEIGHT (m)	TABLE ANGLE (Degree)	RAW VALUE (dBuV)	CORRECTION FACTOR (dB/m)
1	3312.00	70.40 PK	80.68	-10.28	1.11 H	161	35.65	34.75
2	3876.00	68.51 PK	80.68	-12.17	1.11 H	161	32.55	35.96
3	4488.00	68.82 PK	80.68	-11.86	1.11 H	161	31.22	37.60
ANTENNA POLARITY & TEST DISTANCE AT 3 M (VERTICAL)								
NO.	FREQ. (MHz)	EMISSION LEVEL (dBuV/m)	LIMIT (dBuV/m)	MARGIN (dB)	ANTENNA HEIGHT (m)	TABLE ANGLE (Degree)	RAW VALUE (dBuV)	CORRECTION FACTOR (dB/m)
1	3592.00	73.48 PK	80.68	-7.20	1.18 V	194	38.30	35.18
2	3868.00	73.70 PK	80.68	-6.98	1.18 V	194	37.77	35.93
3	4488.00	73.74 PK	80.68	-6.94	1.18 V	194	36.14	37.60

MODULATION TECHNOLOGY	MOFDM	ENVIRONMENTAL CONDITIONS	25 deg. C, 65 %RH, 981hPa
INPUT POWER (SYSTEM)	120Vac, 60 Hz	TESTED BY	Dean Wang
TEST MODE	F		

ANTENNA POLARITY & TEST DISTANCE AT 3 M (HORIZONTAL)								
NO.	FREQ. (MHz)	EMISSION LEVEL (dBuV/m)	LIMIT (dBuV/m)	MARGIN (dB)	ANTENNA HEIGHT (m)	TABLE ANGLE (Degree)	RAW VALUE (dBuV)	CORRECTION FACTOR (dB/m)
1	6432.00	70.23 PK	80.68	-10.45	1.59 H	150	28.42	41.81
2	7004.00	68.60 PK	80.68	-12.08	1.59 H	150	24.89	43.71
3	7828.00	67.47 PK	80.68	-13.21	1.59 H	150	22.01	45.46
ANTENNA POLARITY & TEST DISTANCE AT 3 M (VERTICAL)								
NO.	FREQ. (MHz)	EMISSION LEVEL (dBuV/m)	LIMIT (dBuV/m)	MARGIN (dB)	ANTENNA HEIGHT (m)	TABLE ANGLE (Degree)	RAW VALUE (dBuV)	CORRECTION FACTOR (dB/m)
1	6388.00	74.46 PK	80.68	-6.22	1.00 V	119	32.77	41.69
2	6900.00	73.21 PK	80.68	-7.47	1.00 V	119	29.78	43.43
3	7680.00	71.24 PK	80.68	-9.44	1.00 V	119	25.98	45.26



A D T

MODULATION TECHNOLOGY	MOFDM	ENVIRONMENTAL CONDITIONS	25 deg. C, 65 %RH, 981hPa
INPUT POWER (SYSTEM)	120Vac, 60 Hz	TESTED BY	Dean Wang
TEST MODE	G		

ANTENNA POLARITY & TEST DISTANCE AT 3 M (HORIZONTAL)								
NO.	FREQ. (MHz)	EMISSION LEVEL (dBuV/m)	LIMIT (dBuV/m)	MARGIN (dB)	ANTENNA HEIGHT (m)	TABLE ANGLE (Degree)	RAW VALUE (dBuV)	CORRECTION FACTOR (dB/m)
1	3372.00	65.15 PK	80.68	-15.53	1.17 H	224	30.38	34.77
2	4164.00	67.36 PK	80.68	-13.32	1.17 H	224	30.63	36.73
3	4368.00	67.69 PK	80.68	-12.99	1.17 H	224	30.50	37.19

ANTENNA POLARITY & TEST DISTANCE AT 3 M (VERTICAL)								
NO.	FREQ. (MHz)	EMISSION LEVEL (dBuV/m)	LIMIT (dBuV/m)	MARGIN (dB)	ANTENNA HEIGHT (m)	TABLE ANGLE (Degree)	RAW VALUE (dBuV)	CORRECTION FACTOR (dB/m)
1	3240.00	75.93 PK	80.68	-4.75	1.00 V	304	41.24	34.70
2	3760.00	73.92 PK	80.68	-6.76	1.00 V	304	38.30	35.62
3	4488.00	74.50 PK	80.68	-6.18	1.00 V	304	36.90	37.60

MODULATION TECHNOLOGY	MOFDM	ENVIRONMENTAL CONDITIONS	25 deg. C, 65 %RH, 981hPa
INPUT POWER (SYSTEM)	120Vac, 60 Hz	TESTED BY	Dean Wang
TEST MODE	H		

ANTENNA POLARITY & TEST DISTANCE AT 3 M (HORIZONTAL)								
NO.	FREQ. (MHz)	EMISSION LEVEL (dBuV/m)	LIMIT (dBuV/m)	MARGIN (dB)	ANTENNA HEIGHT (m)	TABLE ANGLE (Degree)	RAW VALUE (dBuV)	CORRECTION FACTOR (dB/m)
1	6820.00	67.55 PK	80.68	-13.13	1.56 H	312	24.44	43.11
2	7052.00	67.94 PK	80.68	-12.74	1.56 H	312	24.15	43.79
3	7588.00	66.22 PK	80.68	-14.46	1.56 H	312	21.02	45.20

ANTENNA POLARITY & TEST DISTANCE AT 3 M (VERTICAL)								
NO.	FREQ. (MHz)	EMISSION LEVEL (dBuV/m)	LIMIT (dBuV/m)	MARGIN (dB)	ANTENNA HEIGHT (m)	TABLE ANGLE (Degree)	RAW VALUE (dBuV)	CORRECTION FACTOR (dB/m)
1	6392.00	74.11 PK	80.68	-6.57	1.22 V	259	32.41	41.70
2	6924.00	72.38 PK	80.68	-8.30	1.22 V	259	28.89	43.49
3	7648.00	70.69 PK	80.68	-9.99	1.22 V	259	25.44	45.25



A D T

4.6 ANTENNA REQUIREMENT

4.6.1 STANDARD APPLICABLE

For intentional device, according to FCC 47 CFR Section 15.203, an intentional radiator shall be designed to ensure that no antenna other than that furnished by the responsible party shall be used with the device.

4.6.2 ANTENNA CONNECTED CONSTRUCTION

The antennas used in this product are Monopole antenna with MCX connector and Inverted F antenna with UFL antenna connector. The maximum Gain of the antenna is 3.44dBi.



A D T

5. PHOTOGRAPHS OF THE TEST CONFIGURATION

Please refer to the attached file (Test Setup Photo).



A D T

6. INFORMATION ON THE TESTING LABORATORIES

We, Bureau Veritas Consumer Products Services (H.K.) Ltd., Taoyuan Branch, were founded in 1988 to provide our best service in EMC, Radio, Telecom and Safety consultation. Our laboratories are accredited and approved by the following approval agencies according to ISO/IEC 17025

USA	FCC, NVLAP
Germany	TUV Rheinland
Japan	VCCI
Norway	NEMKO
Canada	INDUSTRY CANADA , CSA
R.O.C.	TAF, BSMI, NCC
Netherlands	Telefication
Singapore	GOST-ASIA(MOU)
Russia	CERTIS(MOU)

Copies of accreditation certificates of our laboratories obtained from approval agencies can be downloaded from our web site: www.adt.com.tw/index.5/phtml.

If you have any comments, please feel free to contact us at the following:

Linko EMC/RF Lab:

Tel: 886-2-26052180

Fax: 886-2-26051924

Hsin Chu EMC/RF Lab:

Tel: 886-3-5935343

Fax: 886-3-5935342

Hwa Ya EMC/RF/Safety/Telecom Lab:

Tel: 886-3-3183232

Fax: 886-3-3185050

Web Site: www.adt.com.tw

The address and road map of all our labs can be found in our web site also.



A D T

7. APPENDIX A - MODIFICATIONS RECORDERS FOR ENGINEERING CHANGES TO THE EUT BY THE LAB

No any modifications are made to the EUT by the lab during the test.

---END---