

## FCC Test Report

**Report No.:** RF131205E01E-1

**FCC ID:** TX2RTL8812AEBT

**Test Model:** RTL8812AEBT

**Received Date:** Dec. 21, 2015

**Test Date:** Dec. 25, 2015 to Jan. 07, 2016

**Issued Date:** Jan. 28, 2016

**Applicant:** Realtek Semiconductor Corp.

**Address:** No. 2, Innovation Road II, Hsinchu Science Park, Hsinchu 300, Taiwan

**Issued By:** Bureau Veritas Consumer Products Services (H.K.) Ltd., Taoyuan Branch  
Hsin Chu Laboratory

**Lab Address:** E-2, No.1, Li Hsin 1st Road, Hsinchu Science Park, Hsinchu City 300,  
Taiwan R.O.C.

**Test Location (1):** E-2, No.1, Li Hsin 1st Road, Hsinchu Science Park, Hsinchu City 300,  
Taiwan R.O.C.

**Test Location (2):** No. 49, Ln. 206, Wende Rd., Shangshan Tsuen, Chiung Lin Hsiang, Hsin  
Chu Hsien 307, Taiwan R.O.C.



This report is for your exclusive use. Any copying or replication of this report to or for any other person or entity, or use of our name or trademark, is permitted only with our prior written permission. This report sets forth our findings solely with respect to the test samples identified herein. The results set forth in this report are not indicative or representative of the quality or characteristics of the lot from which a test sample was taken or any similar or identical product unless specifically and expressly noted. Our report includes all of the tests requested by you and the results thereof based upon the information that you provided to us. You have 60 days from date of issuance of this report to notify us of any material error or omission caused by our negligence, provided, however, that such notice shall be in writing and shall specifically address the issue you wish to raise. A failure to raise such issue within the prescribed time shall constitute your unqualified acceptance of the completeness of this report, the tests conducted and the correctness of the report contents. Unless specific mention, the uncertainty of measurement has been explicitly taken into account to declare the compliance or non-compliance to the specification. The report must not be used by the client to claim product certification, approval, or endorsement by TAF or any government agencies.

## Table of Contents

<b>Release Control Record</b> .....	<b>4</b>
<b>1 Certificate of Conformity</b> .....	<b>5</b>
<b>2 Summary of Test Results</b> .....	<b>6</b>
2.1 Measurement Uncertainty .....	6
2.2 Modification Record .....	6
<b>3 General Information</b> .....	<b>7</b>
3.1 General Description of EUT .....	7
3.2 Description of Test Modes .....	11
3.2.1 Test Mode Applicability and Tested Channel Detail .....	12
3.3 Duty Cycle of Test Signal .....	14
3.4 Description of Support Units .....	15
3.4.1 Configuration of System under Test .....	15
3.5 General Description of Applied Standard .....	16
<b>4 Test Types and Results</b> .....	<b>17</b>
4.1 Radiated Emission and Bandedge Measurement.....	17
4.1.1 Limits of Radiated Emission and Bandedge Measurement .....	17
4.1.2 Test Instruments .....	18
4.1.3 Test Procedure .....	20
4.1.4 Deviation from Test Standard .....	20
4.1.5 Test Setup.....	21
4.1.6 EUT Operating Condition .....	21
4.1.7 Test Results (Mode 1).....	22
4.1.8 Test Results (Mode 2).....	32
4.2 Transmit Power Measurement .....	42
4.2.1 Limits of Transmit Power Measurement .....	42
4.2.2 Test Setup.....	42
4.2.3 Test Instruments .....	42
4.2.4 Test Procedure .....	42
4.2.5 Deviation from Test Standard .....	42
4.2.6 EUT Operating Condition .....	42
4.2.7 Test Result.....	43
4.3 Peak Power Spectral Density Measurement .....	44
4.3.1 Limits of Peak Power Spectral Density Measurement .....	44
4.3.2 Test Setup.....	44
4.3.3 Test Instruments .....	44
4.3.4 Test Procedure .....	44
4.3.5 Deviation from Test Standard .....	44
4.3.6 EUT Operating Condition .....	44
4.3.7 Test Results .....	45
4.4 Frequency Stability Measurement .....	47
4.4.1 Limits of Frequency Stability Measurement .....	47
4.4.2 Test Setup.....	47
4.4.3 Test Instruments .....	47
4.4.4 Test Procedure .....	47
4.4.5 Deviation from Test Standard .....	47
4.4.6 EUT Operating Condition .....	47
4.4.7 Test Results .....	48
4.5 6dB Bandwidth Measurement .....	49
4.5.1 Limits of 6dB Bandwidth Measurement .....	49
4.5.2 Test Setup.....	49
4.5.3 Test Instruments .....	49
4.5.4 Test Procedure .....	49
4.5.5 Deviation from Test Standard .....	49



4.5.6 EUT Operating Condition .....	49
4.5.7 Test Results .....	50
<b>5 Pictures of Test Arrangements.....</b>	<b>52</b>
<b>Appendix – Information on the Testing Laboratories .....</b>	<b>53</b>



A D T

### Release Control Record

Issue No.	Description	Date Issued
RF131205E01E-1	Original release.	Jan. 28, 2016



## 1 Certificate of Conformity

**Product:** 802.11a/b/g/n/ac RTL8812AE Combo module

**Brand:** Realtek

**Test Model:** RTL8812AEBT

**Sample Status:** ENGINEERING SAMPLE

**Applicant:** Realtek Semiconductor Corp.

**Test Date:** Dec. 21, 2015

**Standard:** 47 CFR FCC Part 15, Subpart E (Section 15.407)  
ANSI C63.10: 2013

The above equipment has been tested by **Bureau Veritas Consumer Products Services (H.K.) Ltd., Taoyuan Branch**, and found compliance with the requirement of the above standards. The test record, data evaluation & Equipment Under Test (EUT) configurations represented herein are true and accurate accounts of the measurements of the sample's EMC characteristics under the conditions specified in this report.

**Prepared by :** Midoli Peng, **Date:** Jan. 28, 2016  
Midoli Peng / Specialist

**Approved by :** May Chen, **Date:** Jan. 28, 2016  
May Chen / Manager

## 2 Summary of Test Results

47 CFR FCC Part 15, Subpart E (SECTION 15.407)			
FCC Clause	Test Item	Result	Remarks
15.407(b) (1/2/3/4/6)	Radiated Emissions & Band Edge Measurement	PASS	Meet the requirement of limit. Minimum passing margin is -1.1dB at 5715.00MHz.
15.407(a)(1/2 /3)	Max Average Transmit Power	PASS	Meet the requirement of limit.
15.407(a)(1/2 /3)	Peak Power Spectral Density	PASS	Meet the requirement of limit.
15.407(e)	6dB bandwidth	PASS	Meet the requirement of limit. (U-NII-3 Band only)
15.407(g)	Frequency Stability	PASS	Meet the requirement of limit.
15.203	Antenna Requirement	PASS	Antenna connector is IPEX not a standard connector.

- NOTE:**
- This report is prepared for FCC Class II change. (Upgrade the standard to section 15.407 under new rule)
  - The DFS report was recorded in another test report<Report No.: RF131205E01E-3>.

### 2.1 Measurement Uncertainty

Where relevant, the following measurement uncertainty levels have been estimated for tests performed on the EUT as specified in CISPR 16-4-2:

Measurement	Frequency	Expanded Uncertainty (k=2) (±)
Radiated Emissions up to 1 GHz	30MHz ~ 1GHz	5.19 dB
Radiated Emissions above 1 GHz	1GHz ~ 6GHz	3.43 dB
	6GHz ~ 18GHz	3.49 dB
	18GHz ~ 40GHz	4.11 dB

### 2.2 Modification Record

There were no modifications required for compliance.

### 3 General Information

#### 3.1 General Description of EUT (WLAN)

Product	802.11a/b/g/n/ac RTL8812AE Combo module
Brand	Realtek
Test Model	RTL8812AEBT
Status of EUT	ENGINEERING SAMPLE
Power Supply Rating	DC 3.3V from host equipment
Modulation Type	CCK, DQPSK, DBPSK for DSSS 64QAM, 16QAM, QPSK, BPSK for OFDM 256QAM for OFDM in 11ac mode
Modulation Technology	DSSS, OFDM
Transfer Rate	802.11b: up to 11Mbps 802.11a /g: up to 54Mbps 802.11n: up to 300Mbps 802.11ac: up to 866.7Mbps
Operating Frequency	<b>For 15.407</b> 5.18 ~ 5.24GHz, 5.26 ~ 5.32GHz, 5.50 ~ 5.58GHz & 5.66 ~ 5.70GHz, 5.745 ~ 5.825GHz
	<b>For 15.247</b> 2.412 ~ 2.462GHz
Number of Channel	<b>For 15.407</b> 21 for 802.11a, 802.11n (HT20), 802.11ac (VHT20) 9 for 802.11n (HT40), 802.11ac (VHT40) 4 for 802.11ac (VHT80)
	<b>For 15.247</b> 11 for 802.11b, 802.11g, 802.11n (HT20) 7 for 802.11n (HT40)
Output Power	<b>For 15.407 (U-NII-3 band)</b> 802.11a: 131.241mW 802.11ac (VHT20): 132.621mW 802.11ac (VHT40): 130.93mW 802.11ac (VHT80): 21.014Mw
	<b>For 15.407 (U-NII-1, U-NII-2A and U-NII-2C Bands)</b> 802.11a: 147.582mW 802.11ac (VHT20): 137.730mW 802.11ac (VHT40): 139.680mW 802.11ac (VHT80): 27.530mW
	<b>For 15.247 (2.4GHz)</b> 802.11b: 123.310mW 802.11g: 572.434mW 802.11n (HT20): 514.717mW 802.11n (HT40): 393.088mW
Antenna Type	Refer to Note
Antenna Connector	Refer to Note
Accessory Device	NA
Data Cable Supplied	NA

**Note:**

1. This report is prepared for FCC Class II change. The difference compared with the Report No.: RF131205E01-1 design is as the following:
  - ◆ Upgrade the standard to section 15.407 under new rule.
2. For U-NII-1, U-NII-2A and 2C Bands: There is no increase in authorized power level, so RF test data refer original test report (Report No.: RF131205E01-1).
3. According to above conditions, therefor only U-NII-3 band and DFS need to be performed (except for Conducted Emission test item). And all data was verified to meet the requirements.
4. There are Bluetooth technology and WLAN technology used for the EUT.
5. For WLAN: 2.4GHz and 5GHz technology cannot transmit at same time.
6. WLAN & BT technology can transmit at same time.
7. The antennas provided to the EUT, please refer to the following table:

No.	Brand	Model	Antenna Type	Peak gain with cable loss (dBi) (2.4GHz)	Peak gain with cable loss(dBi) (5GHz)	Cable Loss (dB) (2.4GHz)	Cable Loss (dB) (5GHz)	Connector Type
1	LYNwave	ALA110-222050-300010 (Main) ALA110-222050-300010 (Aux)	PIFA	3.5 3.5	5 5	NA NA	NA NA	IPEX
2	JOYMAX	TWF-614XMPXX-500 (Main) TWF-614XMPXX-500 (Aux)	Dipole	3 3	5 5	NA NA	NA NA	IPEX
3	WGT	SKA91WMPB02+A (Tx1) SKA91WMPB01+A (Tx2)	PIFA	0.82 -2.23	0.94 2.18	-1.32 -0.75	-2.04 -1.17	IPEX
4	JEM	1510-0122-0027 (Tx1) 1510-0122-0027 (Tx2)	PIFA	3.23 2.31	4.89 1.89	NA NA	NA NA	RF
5	FVC	K05007014501(6-23-7W25H-010) (Tx1) K05007014501(6-23-7W25H-010) (Tx2)	PIFA	2.85 1.59	2.46 2.91	NA NA	NA NA	IPEX
6	JEM	1510-0122-0022(IA-120073) (Tx1) 1510-0122-0022(IA-120073) (Tx2)	PIFA	2.23 2.21	1.69 1.84	NA NA	NA NA	RF
7	WGT	SK81WMPB01+A (Tx1) SK81WMPB02+A (Tx2)	PIFA	1.79 0.66	1.49 -0.40	-1.88 -2.95	-3.17 -4.96	IPEX
8	WGT	SKW2UWMPB01+A (Tx1) SKW2UWMPB01+A (Tx2)	PIFA	1.36 2.88	1.92 3.16	NA NA	NA NA	IPEX
9	WGT	SKW25WMPB01+A (Tx1) SKW25WMPB01+A (Tx2)	PIFA	0.72 0.49	-0.72 -0.71	-1.41 -1.39	-2.18 -2.15	IPEX
10	WGT	SK549WMPB01+A (Tx1) SK549WMPB02+A (Tx2)	PIFA	-0.17 -2.24	-0.13 0.03	-1.04 -0.88	-1.94 -1.64	IPEX
11	WGT	SK110WMPB01+A (Tx1) SK110WMPB02+A (Tx2)	PIFA	1.05 -0.41	1.08 2.32	-0.98 -0.99	-1.52 -1.54	IPEX
12	WGT	SKW31WMPB01+A (Tx1) SKW31WMPB01+A (Tx2)	PIFA	1.85 3.14	1.74 2.10	NA NA	NA NA	IPEX
13	FVC	6-23-7B51M-031 (Tx1) 6-23-7B51M-031 (Tx2)	PIFA	1.58 1.75	2.54 2.24	NA NA	NA NA	IPEX
14	FVC	6-23-7E51Q-011 (Tx1) 6-23-7E51Q-011 (Tx2)	PIFA	2.70 2.19	1.57 2.94	NA NA	NA NA	IPEX
15	FVC	6-23-7B710-022 (WM1) 6-23-7B710-022 (WM2)	PIFA	1.51 2.04	2.99 3.02	NA NA	NA NA	IPEX
16	WGT	SKM11WMPB03+A (Tx1) SKM11WMPB02+D (Tx2)	PIFA	-1.84 -2.93	0.44 1.35	1.17 0.89	2.02 1.54	IPEX



No.	Brand	Model	Antenna Type	Peak gain with cable loss (dBi) (2.4GHz)	Peak gain with cable loss(dBi) (5GHz)	Cable Loss (dB) (2.4GHz)	Cable Loss (dB) (5GHz)	Connector Type
17	WGT	SKW23WMPB01+A (Tx1) SKW23WMPB02+A (Tx2)	PIFA	-1.61 -2.84	-0.14 -0.96	-2.10 -2.07	-3.25 -3.20	IPEX
18	WGT	SKW24WMPB01+B (WM1) SKW24WMPB01+B (WM2)	PIFA	1.25 3.17	1.95 2.42	NA NA	NA NA	IPEX
19	FVC	K05007015501(6-23-7W244-020-1) (Tx1) K05007015501(6-23-7W244-020-1) (Tx2)	PIFA	2.53 2.28	2.86 2.97	NA NA	NA NA	IPEX
20	FVC	K05007014201(6-23-7W25P-020) (Tx1) K05007014201(6-23-7W25P-020) (Tx2)	PIFA	3.00 1.52	2.82 2.21	NA NA	NA NA	IPEX
21	WGT	SKW10WMPB01+A (Tx1) SKW10WMPB02+A (Tx2)	PIFA	0.85 0.44	0.75 1.24	-1.56 -1.53	-2.42 -2.36	IPEX
22	WGT	SKCZTWMPB01+A (Tx1) SKCZTWMPB02+A (Tx2)	PIFA	0.46 -0.79	2.80 1.03	-1.56 -1.53	-2.42 -2.36	IPEX
23	JEM	IA-120266 (Tx1) IA-120267 (Tx2)	PIFA	2.60 0.53	2.61 2.60	2.12 1.76	3.48 2.87	IPEX
24	WGT	SK547WMPB01+A (Tx1) SK549WMPB02+A (Tx2)	PIFA	-0.66 0.78	-0.19 2.06	-1.42 -1.43	-2.20 -2.21	IPEX
25	WGT	SK555WMPB01+B (Tx1) SK555WMPB02+B (Tx2)	PIFA	0.76 0.09	1.97 0.56	-1.83 -1.80	-2.83 -2.78	IPEX
26	WGT	SK65EWMPB01+A (Tx1) SK650WMPB02+A (Tx2)	PIFA	0.42 -0.13	0.11 1.27	-1.56 -0.61	-2.41 -0.94	IPEX
27	WGT	SK670WMPB01+A (Tx1) SK670WMPB02+A (Tx2)	PIFA	1.48 1.15	-0.44 0.42	-2.47 -1.93	-3.82 -2.99	IPEX
28	WGT	SK740WMPB01+A (Tx1) SK740WMPB02+A (Tx2)	PIFA	-0.93 0.20	0.96 0.86	-1.39 -1.26	-2.16 -1.95	IPEX
29	WGT	SK840WMPB01+B_SN (Tx1) SK840WMPB01+B_SN (Tx2)	PIFA	3.03 0.55	4.16 0.90	-1.12 -1.20	-1.74 -1.86	IPEX
30	WGT	SK94SWMPB01+B (TX1) SK94SWMPB01+B (TX2)	PIFA	0.76 0.46	1.12 1.44	-0.32 -0.44	-0.50 -0.68	IPEX
31	WGT	SK94TWMPB01+B (TX1) SK94TWMPB01+B (TX2)	PIFA	1.32 1.86	2.59 1.57	-0.59 -0.71	-0.91 -1.10	IPEX
32	WGT	SK50SWMPB01+A (TX1) SK50SWMPB02+A (TX2)	PIFA	-0.03 -0.13	1.25 2.13	-0.86 -0.72	-1.32 -1.12	IPEX
33	WGT	SK94TWMPB01+D (TX1) SK94TWMPB01+D (TX2)	PIFA	1.32 1.86	2.59 1.57	-0.59 -0.71	-0.91 -1.10	IPEX
34	WGT	SKC45WMPB03+B (WM1) SKC45WMPB03+B (WM2)	PIFA	2.46 2.91	2.90 2.67	NA NA	NA NA	IPEX
35	FVC	K05007015801 (WM1) K05007015901 (WM2)	PIFA	3.12 1.01	3.51 1.93	NA NA	NA NA	RF
36	WGT	SK345WMPB01+A (WM1) SK345WMPB02+A (WM2)	PIFA	0.86 2.51	2.94 3.25	NA NA	NA NA	IPEX
37	FVC	K05007014901 (WM1) K05007015001 (WM2)	PIFA	1.85 1.94	1.35 1.99	NA NA	NA NA	IPEX
38	WGT	SKX51WMPB01+C (WM1) SKX51WMPB02+C (WM2)	PIFA	3.2 2.76	2.28 2.51	NA NA	NA NA	IPEX

No.	Brand	Model	Antenna Type	Peak gain with cable loss (dBi) (2.4GHz)	Peak gain with cable loss(dBi) (5GHz)	Cable Loss (dB) (2.4GHz)	Cable Loss (dB) (5GHz)	Connector Type
39	INPAQ	WA-P-LB-02-122 (Main) WA-P-LB-01-072 (Aux)	PIFA	-1.41 -0.33	-2.44 -3.87	1.23 1.86	2.06 3.12	IPEX
40	Smart Approach	SE-ECZ50-001 (Tx1) SE-ECZ50-002 (Tx2)	PIFA	-1.37 -2.17	1.83 1.86	0.96 1.45	1.73 2.62	IPEX
41	INPAQ	WA-P-LB-02-121 (Main) WA-P-LB-01-071 (Aux)	PIFA	-2.26 -4.63	-2.87 -2.49	1.32 1.95	2.22 3.28	IPEX
42	Smart Approach	SE-ECZ70-001 (Tx1) SE-ECZ70-002 (Tx2)	PIFA	-0.65 -2.39	1.52 0.58	1.03 1.52	1.87 2.76	IPEX

**Antenna 1 & 2** were chosen for final test.

8. The EUT incorporates a MIMO function with beamforming.(Except for 802.11a/b/g)

<b>For 2.4GHz Band</b>			
MODULATION MODE	DATA RATE (MCS)	TX & RX CONFIGURATION	
802.11b	1 ~ 11Mbps	1TX	1RX
802.11g	6 ~ 54Mbps	1TX / 2TX	2RX
802.11n (HT20)	MCS 0~7	1TX / 2TX	2RX
	MCS 8~15	2TX	2RX
802.11n (HT40)	MCS 0~7	1TX / 2TX	2RX
	MCS 8~15	2TX	2RX
<b>For 5GHz Band</b>			
MODULATION MODE	DATA RATE (MCS)	TX & RX CONFIGURATION	
802.11a	6 ~ 54Mbps	1TX / 2TX	2RX
802.11n (HT20)	MCS 0~7	1TX / 2TX	2RX
	MCS 8~15	2TX	2RX
802.11n (HT40)	MCS 0~7	1TX / 2TX	2RX
	MCS 8~15	2TX	2RX
802.11ac (VHT20)	MCS 0~8, Nss=1	1TX / 2TX	2RX
	MCS 0~8, Nss=2	2TX	2RX
802.11ac (VHT40)	MCS 0~9, Nss=1	1TX / 2TX	2RX
	MCS 0~9, Nss=2	2TX	2RX
802.11ac (VHT80)	MCS 0~9, Nss=1	1TX / 2TX	2RX
	MCS 0~9, Nss=2	2TX	2RX

Note: 1. The modulation and bandwidth are similar for 802.11n mode for 20MHz (40MHz) and 802.11ac mode for 20MHz (40MHz), therefore investigated worst case to representative mode in test report. (Final test mode refer section 3.2.1)

2. All of modulation mode support beamforming function except 802.11a/b/g modulation mode.

3. 1Tx, 1Rx mode will fix transmission on Chain (0).

9. This device implement independent power value in different scenario in U-NII band 1. In the other band only implement one power value in all.

10. The above EUT information is declared by manufacturer and for more detailed features description, please refer to the manufacturer's specifications or user's manual.

### 3.2 Description of Test Modes

#### FOR 5745 ~ 5825MHz:

5 channels are provided for 802.11a, 802.11n (HT20), 802.11ac (VHT20):

Channel	Frequency	Channel	Frequency
149	5745MHz	161	5805MHz
153	5765MHz	165	5825MHz
157	5785MHz		

2 channels are provided for 802.11n (HT40), 802.11ac (VHT40):

Channel	Frequency	Channel	Frequency
151	5755MHz	159	5795MHz

1 channel is provided for 802.11ac (VHT80):

Channel	Frequency
155	5775MHz

### 3.2.1 Test Mode Applicability and Tested Channel Detail

EUT CONFIGURE MODE	APPLICABLE TO				DESCRIPTION
	RE $\geq$ 1G	RE $<$ 1G	PLC	APCM	
1	√	√	-	√	With PIFA antenna
2	√	√	-	-	With Dipole antenna

Where **RE $\geq$ 1G**: Radiated Emission above 1GHz      **RE $<$ 1G**: Radiated Emission below 1GHz  
**PLC**: Power Line Conducted Emission      **APCM**: Antenna Port Conducted Measurement

**NOTE:**

1. The EUT's antenna (PIFA) had been pre-tested on the positioned of each 3 axis. The worst case was found when positioned on **Y-plane**.
2. "-" means no effect.

#### **Radiated Emission Test (Above 1GHz):**

- Pre-Scan has been conducted to determine the worst-case mode from all possible combinations between available modulations, data rates and antenna ports (if EUT with antenna diversity architecture).
- Following channel(s) was (were) selected for the final test as listed below.

MODE	FREQ. BAND (MHz)	AVAILABLE CHANNEL	TESTED CHANNEL	MODULATION TECHNOLOGY	MODULATION TYPE	DATA RATE (Mbps)
802.11a	5745-5825	149 to 165	149, 157, 165	OFDM	BPSK	6
<b>Beamforming MODE</b>						
MODE	FREQ. BAND (MHz)	AVAILABLE CHANNEL	TESTED CHANNEL	MODULATION TECHNOLOGY	MODULATION TYPE	DATA RATE (Mbps)
802.11ac (VHT20)	5745-5825	149 to 165	149, 157, 165	OFDM	BPSK	6.5
802.11ac (VHT40)		151 to 159	151, 159	OFDM	BPSK	13.5
802.11ac (VHT80)		155	155	OFDM	BPSK	29.3

#### **Radiated Emission Test (Below 1GHz):**

- Pre-Scan has been conducted to determine the worst-case mode from all possible combinations between available modulations, data rates and antenna ports (if EUT with antenna diversity architecture).
- Following channel(s) was (were) selected for the final test as listed below.

<b>Beamforming MODE</b>						
MODE	FREQ. BAND (MHz)	AVAILABLE CHANNEL	TESTED CHANNEL	MODULATION TECHNOLOGY	MODULATION TYPE	DATA RATE (Mbps)
802.11ac (VHT20)	5745-5825	149 to 165	165	OFDM	BPSK	6.5

**Antenna Port Conducted Measurement:**

- This item includes all test value of each mode, but only includes spectrum plot of worst value of each mode.
- Pre-Scan has been conducted to determine the worst-case mode from all possible combinations between available modulations, data rates and antenna ports (if EUT with antenna diversity architecture).
- Following channel(s) was (were) selected for the final test as listed below.

MODE	FREQ. BAND (MHz)	AVAILABLE CHANNEL	TESTED CHANNEL	MODULATION TECHNOLOGY	MODULATION TYPE	DATA RATE (Mbps)
802.11a	5745-5825	149 to 165	149, 157, 165	OFDM	BPSK	6
<b>Beamforming MODE</b>						
MODE	FREQ. BAND (MHz)	AVAILABLE CHANNEL	TESTED CHANNEL	MODULATION TECHNOLOGY	MODULATION TYPE	DATA RATE (Mbps)
802.11ac (VHT20)	5745-5825	149 to 165	149, 157, 165	OFDM	BPSK	6.5
802.11ac (VHT40)		151 to 159	151, 159	OFDM	BPSK	13.5
802.11ac (VHT80)		155	155	OFDM	BPSK	29.3

**Test Condition:**

APPLICABLE TO	ENVIRONMENTAL CONDITIONS	INPUT POWER (SYSTEM)	TESTED BY
RE≥1G	24deg. C, 63%RH	120Vac, 60Hz	Jyunchun Lin
RE<1G	25deg. C, 62%RH	120Vac, 60Hz	Jyunchun Lin
APCM	25deg. C, 60%RH	120Vac, 60Hz	Gary Cheng

### 3.3 Duty Cycle of Test Signal

Duty cycle of test signal is 100 %, duty factor is not required.

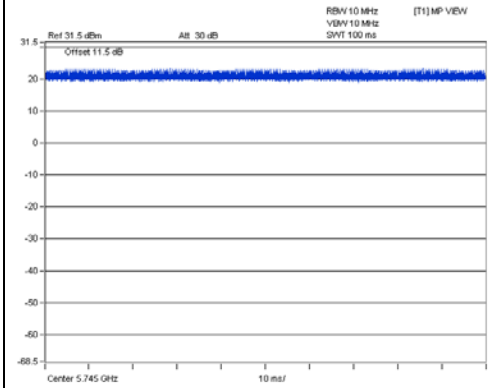
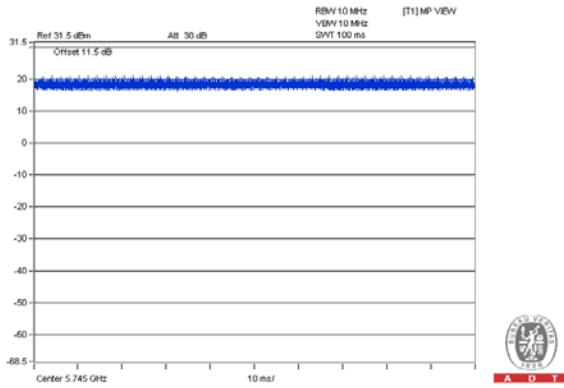
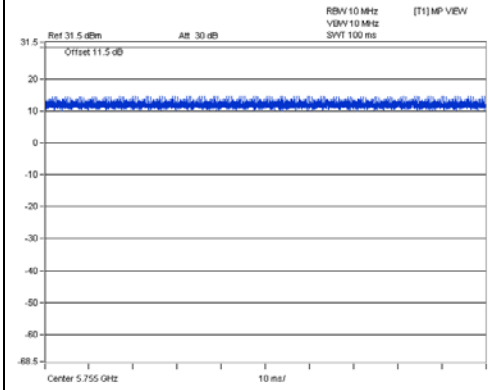
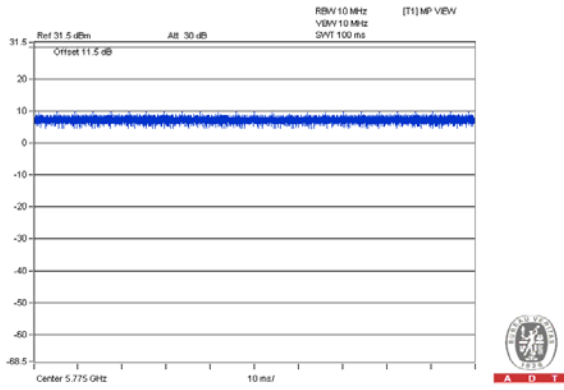
**802.11a****802.11ac (VHT20)****802.11ac (VHT40)****802.11ac (VHT80)**

### 3.4 Description of Support Units

The EUT has been tested as an independent unit together with other necessary accessories or support units. The following support units or accessories were used to form a representative test configuration during the tests.

ID	Product	Brand	Model No.	Serial No.	FCC ID	Remarks
A.	NOTEBOOK COMPUTER	DELL	E5430	GM1SKV1	FCC DoC	Provided by Lab
B.	PCI-E TEST TOOL	Realtek	NA	NA	NA	Supplied by Client

Note:

1. All power cords of the above support units are non-shielded (1.8m).

#### 3.4.1 Configuration of System under Test

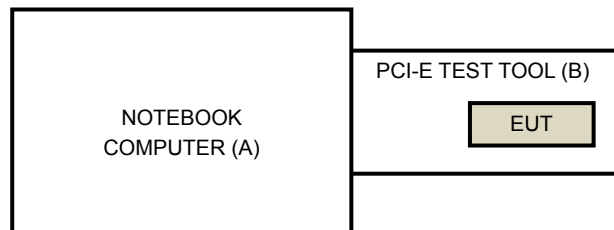

### 3.5 General Description of Applied Standard

The EUT is a RF Product. According to the specifications of the manufacturer, it must comply with the requirements of the following standards:

**FCC Part 15, Subpart E (15.407)**  
**KDB 789033 D02 General UNII Test Procedure New Rules v01**  
**KDB 662911 D01 Multiple Transmitter Output v02r01**  
ANSI C63.10-2013

All test items have been performed and recorded as per the above standards.

**NOTE:** The EUT has been verified to comply with the requirements of FCC Part 15, Subpart B, Class B (DoC). The test report has been issued separately.



## 4 Test Types and Results

### 4.1 Radiated Emission and Bandedge Measurement

#### 4.1.1 Limits of Radiated Emission and Bandedge Measurement

Radiated emissions which fall in the restricted bands must comply with the radiated emission limits specified as below table.

Frequencies (MHz)	Field Strength (microvolts/meter)	Measurement Distance (meters)
0.009 ~ 0.490	2400/F(kHz)	300
0.490 ~ 1.705	24000/F(kHz)	30
1.705 ~ 30.0	30	30
30 ~ 88	100	3
88 ~ 216	150	3
216 ~ 960	200	3
Above 960	500	3

#### NOTE:

1. The lower limit shall apply at the transition frequencies.
2. Emission level (dBuV/m) = 20 log Emission level (uV/m).
3. For frequencies above 1000MHz, the field strength limits are based on average detector, however, the peak field strength of any emission shall not exceed the maximum permitted average limits, specified above by more than 20dB under any condition of modulation.

#### LIMITS OF UNWANTED EMISSION OUT OF THE RESTRICTED BANDS

APPLICABLE TO	LIMIT	
789033 D02 General UNII Test Procedure New Rules v01	FIELD STRENGTH AT 3m	
	PK:74 (dBuV/m)	AV:54 (dBuV/m)
APPLICABLE TO	EIRP LIMIT	EQUIVALENT FIELD STRENGTH AT 3m
15.407(b)(1)	PK:-27 (dBm/MHz)	PK:68.2(dBuV/m)
15.407(b)(2)		
15.407(b)(3)		
15.407(b)(4)	PK:-27 (dBm/MHz) <sup>*1</sup> PK:-17 (dBm/MHz) <sup>*2</sup>	PK: 68.2(dBuV/m) <sup>*1</sup> PK:78.2 (dBuV/m) <sup>*2</sup>

**NOTE:** <sup>\*1</sup> beyond 10MHz of the band edge <sup>\*2</sup> within 10 MHz of band edge

The following formula is used to convert the equipment isotropic radiated power (eirp) to field strength:

$$E = \frac{1000000\sqrt{30P}}{3} \mu\text{V/m, where P is the eirp (Watts).}$$

#### 4.1.2 Test Instruments

<b>DESCRIPTION &amp; MANUFACTURER</b>	<b>MODEL NO.</b>	<b>SERIAL NO.</b>	<b>CALIBRATED DATE</b>	<b>CALIBRATED UNTIL</b>
Test Receiver Agilent	N9038A	MY54450088	July 24, 2015	July 23, 2016
Pre-Amplifier <sup>(*)</sup> EMCI	EMC001340	980142	Jan. 13, 2014	Jan. 12, 2016
Loop Antenna <sup>(*)</sup> Electro-Metrics	EM-6879	264	Dec. 16, 2014	Dec. 15, 2016
RF Cable	NA	LOOPCAB-001 LOOPCAB-002	Jan. 18, 2015	Jan. 17, 2016
Pre-Amplifier Mini-Circuits	ZFL-1000VH2 B	AMP-ZFL-06	Nov. 11, 2015	Nov. 10, 2016
Trilog Broadband Antenna SCHWARZBECK	VULB 9168	9168-406	Feb. 03, 2015	Feb. 02, 2016
RF Cable	8D	966-4-1 966-4-2 966-4-3	Apr. 03, 2015	Apr. 02, 2016
Horn_Antenna SCHWARZBECK	BBHA 9120D	9120D-783	Feb. 06, 2015	Feb. 05, 2016
Pre-Amplifier Agilent	8449B	3008A01922	Sep. 19, 2015	Sep. 18, 2016
RF Cable	EMC104-SM- SM-2000 EMC104-SM- SM-5000 EMC104-SM- SM-5000	150318 150323 150324	Mar. 31, 2015	Mar. 30, 2016
Pre-Amplifier EMCI	EMC184045	980143	Jan. 16, 2015	Jan. 15, 2016
Horn_Antenna SCHWARZBECK	BBHA 9170	BBHA9170608	Feb. 05, 2015	Feb. 04, 2016
RF Cable	SUCOFLEX 102	36432/2 36441/2	Jan. 17, 2015	Jan. 16, 2016
Software	ADT_Radiated _V8.7.07	NA	NA	NA
Antenna Tower & Turn Table CT	NA	NA	NA	NA
Power Meter Anritsu	ML2495A	1014008	Apr. 28, 2015	Apr. 27, 2016
Power Sensor Anritsu	MA2411B	0917122	Apr. 28, 2015	Apr. 27, 2016
Spectrum Analyzer R&S	FSP40	100060	May 08, 2015	May 07, 2016
Temperature & Humidity Chamber GIANTFORCE	GTH-150-40-S P-AR	MAA0812-008	Jan. 12, 2015	Jan. 11, 2016

**Note:**

1. The calibration interval of the above test instruments is 12 months and the calibrations are traceable to NML/ROC and NIST/USA.
2. \*The calibration interval of the above test instruments is 24 months and the calibrations are traceable to NML/ROC and NIST/USA.
3. Loop antenna was used for all emissions below 30 MHz.
4. The test was performed in 966 Chamber No. 4.
5. The FCC Site Registration No. is 292998
6. The CANADA Site Registration No. is 20331-2
- 7 Tested Date: Dec. 25, 2015 to Jan. 07, 2016

#### 4.1.3 Test Procedure

- a. The EUT was placed on the top of a rotating table 0.8 meters (for below 1GHz) / 1.5 meters (for above 1GHz) above the ground at 3 meter chamber room for test. The table was rotated 360 degrees to determine the position of the highest radiation.
- b. The EUT was set 3 meters away from the interference-receiving antenna, which was mounted on the top of a variable-height antenna tower.
- c. The height of antenna is varied from one meter to four meters above the ground to determine the maximum value of the field strength. Both horizontal and vertical polarizations of the antenna are set to make the measurement.
- d. For each suspected emission, the EUT was arranged to its worst case and then the antenna was tuned to heights from 1 meter to 4 meters and the rotatable table was turned from 0 degrees to 360 degrees to find the maximum reading.
- e. The test-receiver system was set to quasi-peak detect function and specified bandwidth with maximum hold mode when the test frequency is below 1 GHz.
- f. The test-receiver system was set to peak and average detect function and specified bandwidth with maximum hold mode when the test frequency is above 1 GHz. If the peak reading value also meets average limit, measurement with the average detector is unnecessary.

**Note:**

1. The resolution bandwidth and video bandwidth of test receiver/spectrum analyzer is 120kHz for Quasi-peak detection (QP) at frequency below 1GHz.
2. The resolution bandwidth of test receiver/spectrum analyzer is 1 MHz and the video bandwidth is 3 MHz for Peak detection (PK) at frequency above 1GHz.
3. The resolution bandwidth of test receiver/spectrum analyzer is 1MHz and the video bandwidth is 3MHz for RMS Average (Duty cycle < 98%) for Average detection (AV) at frequency above 1GHz, then the measurement results was added to a correction factor ( $10 \log(1/\text{duty cycle})$ ).
4. The resolution bandwidth of test receiver/spectrum analyzer is 1MHz and the video bandwidth is 10Hz (Duty cycle  $\geq 98\%$ ) for Average detection (AV) at frequency above 1GHz.
5. All modes of operation were investigated and the worst-case emissions are reported.

#### 4.1.4 Deviation from Test Standard

No deviation.

#### 4.1.5 Test Setup

##### <Frequency Range below 1GHz>

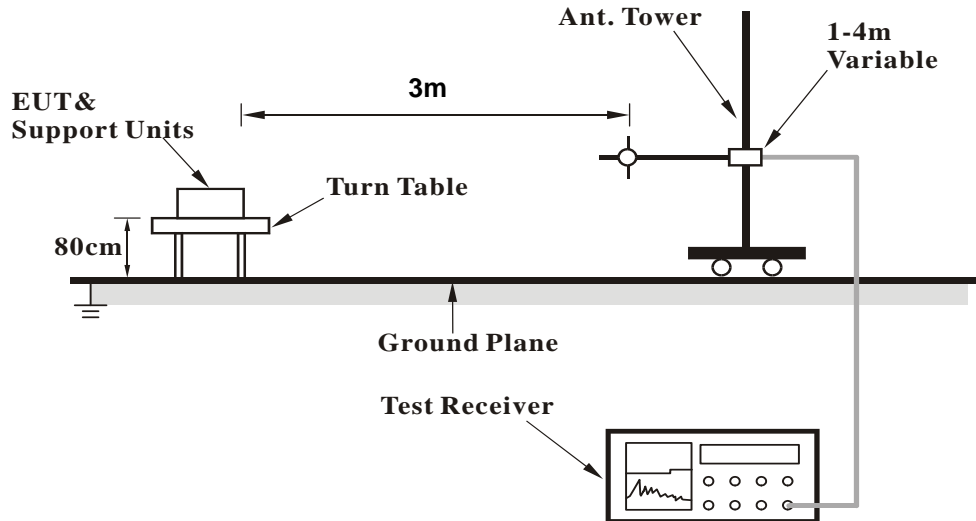

##### <Frequency Range above 1GHz>

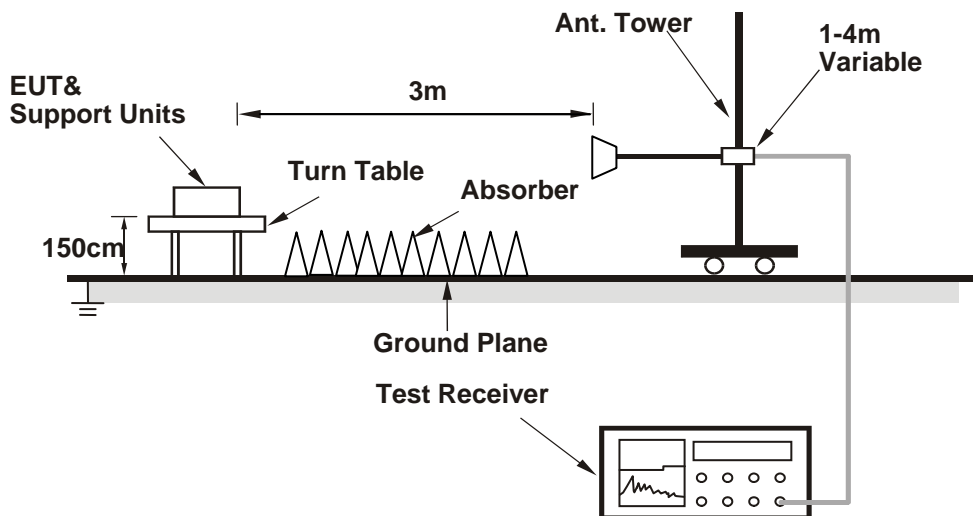

For the actual test configuration, please refer to the attached file (Test Setup Photo).

#### 4.1.6 EUT Operating Condition

1. Connect the EUT with the support unit 1 (Notebook Computer) which is placed on a testing table.
2. The communication partner run test program "MP819xVC.exe\_V0.28.119.2010" to enable EUT under transmission/receiving condition continuously at specific channel frequency.

**4.1.7 Test Results (Mode 1)**
**Above 1GHz Data**
**802.11a**

<b>CHANNEL</b>	TX Channel 149	<b>DETECTOR FUNCTION</b>	Peak (PK)
<b>FREQUENCY RANGE</b>	1GHz ~ 25GHz		Average (AV)

**ANTENNA POLARITY & TEST DISTANCE: HORIZONTAL AT 3 M**

NO.	FREQ. (MHz)	EMISSION LEVEL (dBuV/m)	LIMIT (dBuV/m)	MARGIN (dB)	ANTENNA HEIGHT (m)	TABLE ANGLE (Degree)	RAW VALUE (dBuV)	CORRECTION FACTOR (dB/m)
1	#5715.00	56.4 PK	74.0	-17.6	2.06 H	9	50.48	5.92
2	#5715.00	43.2 AV	54.0	-10.8	2.06 H	9	37.28	5.92
3	#5725.00	60.3 PK	78.2	-17.9	2.06 H	9	54.39	5.91
4	*5745.00	112.1 PK			2.06 H	9	106.21	5.89
5	*5745.00	103.2 AV			2.06 H	9	97.31	5.89
6	11490.00	52.1 PK	74.0	-21.9	1.66 H	146	39.71	12.39
7	11490.00	42.9 AV	54.0	-11.1	1.66 H	146	30.51	12.39
8	#17235.00	57.1 PK	74.0	-16.9	1.51 H	148	36.11	20.99
9	#17235.00	44.8 AV	54.0	-9.2	1.51 H	148	23.81	20.99

**ANTENNA POLARITY & TEST DISTANCE: VERTICAL AT 3 M**

NO.	FREQ. (MHz)	EMISSION LEVEL (dBuV/m)	LIMIT (dBuV/m)	MARGIN (dB)	ANTENNA HEIGHT (m)	TABLE ANGLE (Degree)	RAW VALUE (dBuV)	CORRECTION FACTOR (dB/m)
1	#5715.00	51.2 PK	74.0	-22.8	1.40 V	148	45.28	5.92
2	#5715.00	39.1 AV	54.0	-14.9	1.40 V	148	33.18	5.92
3	#5725.00	55.1 PK	78.2	-23.1	1.40 V	148	49.19	5.91
4	*5745.00	106.8 PK			1.40 V	148	100.91	5.89
5	*5745.00	97.9 AV			1.40 V	148	92.01	5.89
6	11490.00	51.9 PK	74.0	-22.1	1.86 V	42	39.51	12.39
7	11490.00	43.3 AV	54.0	-10.7	1.86 V	42	30.91	12.39
8	#17235.00	56.8 PK	74.0	-17.2	1.76 V	59	35.81	20.99
9	#17235.00	44.3 AV	54.0	-9.7	1.76 V	59	23.31	20.99

**REMARKS:**

- Emission Level(dBuV/m) = Raw Value(dBuV) + Correction Factor(dB/m)
- Correction Factor(dB/m) = Antenna Factor(dB/m) + Cable Factor(dB) – Pre-Amplifier Factor(dB)
- The other emission levels were very low against the limit.
- Margin value = Emission Level – Limit value
- " \* ": Fundamental frequency.
- " # ": The radiated frequency is out of the restricted band.

<b>CHANNEL</b>	TX Channel 157	<b>DETECTOR FUNCTION</b>	Peak (PK)
<b>FREQUENCY RANGE</b>	1GHz ~ 25GHz		Average (AV)

**ANTENNA POLARITY & TEST DISTANCE: HORIZONTAL AT 3 M**

NO.	FREQ. (MHz)	EMISSION LEVEL (dBuV/m)	LIMIT (dBuV/m)	MARGIN (dB)	ANTENNA HEIGHT (m)	TABLE ANGLE (Degree)	RAW VALUE (dBuV)	CORRECTION FACTOR (dB/m)
1	*5785.00	113.4 PK			2.03 H	2	107.55	5.85
2	*5785.00	104.8 AV			2.03 H	2	98.95	5.85
3	11570.00	52.2 PK	74.0	-21.8	1.62 H	146	39.88	12.32
4	11570.00	42.8 AV	54.0	-11.2	1.62 H	146	30.48	12.32
5	#17355.00	57.2 PK	74.0	-16.8	1.42 H	145	35.93	21.27
6	#17355.00	44.9 AV	54.0	-9.1	1.42 H	145	23.63	21.27

**ANTENNA POLARITY & TEST DISTANCE: VERTICAL AT 3 M**

NO.	FREQ. (MHz)	EMISSION LEVEL (dBuV/m)	LIMIT (dBuV/m)	MARGIN (dB)	ANTENNA HEIGHT (m)	TABLE ANGLE (Degree)	RAW VALUE (dBuV)	CORRECTION FACTOR (dB/m)
1	*5785.00	108.3 PK			1.35 V	148	102.45	5.85
2	*5785.00	99.3 AV			1.35 V	148	93.45	5.85
3	11570.00	52.2 PK	74.0	-21.8	1.78 V	35	39.88	12.32
4	11570.00	43.2 AV	54.0	-10.8	1.78 V	35	30.88	12.32
5	#17355.00	56.9 PK	74.0	-17.1	1.78 V	65	35.63	21.27
6	#17355.00	44.5 AV	54.0	-9.5	1.78 V	65	23.23	21.27

**REMARKS:**

1. Emission Level(dBuV/m) = Raw Value(dBuV) + Correction Factor(dB/m)
2. Correction Factor(dB/m) = Antenna Factor(dB/m) + Cable Factor(dB) – Pre-Amplifier Factor(dB)
3. The other emission levels were very low against the limit.
4. Margin value = Emission Level – Limit value
5. " \* ": Fundamental frequency.
6. " # ": The radiated frequency is out of the restricted band.

<b>CHANNEL</b>	TX Channel 165	<b>DETECTOR FUNCTION</b>	Peak (PK)
<b>FREQUENCY RANGE</b>	1GHz ~ 25GHz		Average (AV)

**ANTENNA POLARITY & TEST DISTANCE: HORIZONTAL AT 3 M**

NO.	FREQ. (MHz)	EMISSION LEVEL (dBuV/m)	LIMIT (dBuV/m)	MARGIN (dB)	ANTENNA HEIGHT (m)	TABLE ANGLE (Degree)	RAW VALUE (dBuV)	CORRECTION FACTOR (dB/m)
1	*5825.00	113.2 PK			1.97 H	4	107.42	5.78
2	*5825.00	104.4 AV			1.97 H	4	98.62	5.78
3	#5850.00	67.9 PK	78.2	-10.3	1.97 H	4	62.17	5.73
4	#5860.00	67.7 PK	74.0	-6.3	1.97 H	4	62.00	5.70
5	#5860.00	52.0 AV	54.0	-2.0	1.97 H	4	46.30	5.70
6	11650.00	52.1 PK	74.0	-21.9	1.66 H	158	39.74	12.36
7	11650.00	42.8 AV	54.0	-11.2	1.66 H	158	30.44	12.36
8	#17475.00	56.8 PK	74.0	-17.2	1.47 H	143	35.63	21.17
9	#17475.00	44.5 AV	54.0	-9.5	1.47 H	143	23.33	21.17

**ANTENNA POLARITY & TEST DISTANCE: VERTICAL AT 3 M**

NO.	FREQ. (MHz)	EMISSION LEVEL (dBuV/m)	LIMIT (dBuV/m)	MARGIN (dB)	ANTENNA HEIGHT (m)	TABLE ANGLE (Degree)	RAW VALUE (dBuV)	CORRECTION FACTOR (dB/m)
1	*5825.00	108.1 PK			1.36 V	143	102.32	5.78
2	*5825.00	98.5 AV			1.36 V	143	92.72	5.78
3	#5850.00	62.1 PK	78.2	-16.1	1.36 V	143	56.37	5.73
4	#5860.00	62.3 PK	74.0	-11.7	1.36 V	143	56.60	5.70
5	#5860.00	47.1 AV	54.0	-6.9	1.36 V	143	41.40	5.70
6	11650.00	52.2 PK	74.0	-21.8	1.84 V	47	39.84	12.36
7	11650.00	43.3 AV	54.0	-10.7	1.84 V	47	30.94	12.36
8	#17475.00	57.0 PK	74.0	-17.0	1.74 V	65	35.83	21.17
9	#17475.00	44.6 AV	54.0	-9.4	1.74 V	65	23.43	21.17

**REMARKS:**

1. Emission Level(dBuV/m) = Raw Value(dBuV) + Correction Factor(dB/m)
2. Correction Factor(dB/m) = Antenna Factor(dB/m) + Cable Factor(dB) – Pre-Amplifier Factor(dB)
3. The other emission levels were very low against the limit.
4. Margin value = Emission Level – Limit value
5. " \* ": Fundamental frequency.
6. " # ": The radiated frequency is out of the restricted band.



**802.11ac (VHT20)**

<b>CHANNEL</b>	TX Channel 149	<b>DETECTOR FUNCTION</b>	Peak (PK)
<b>FREQUENCY RANGE</b>	1GHz ~ 25GHz		Average (AV)

**ANTENNA POLARITY & TEST DISTANCE: HORIZONTAL AT 3 M**

NO.	FREQ. (MHz)	EMISSION LEVEL (dBuV/m)	LIMIT (dBuV/m)	MARGIN (dB)	ANTENNA HEIGHT (m)	TABLE ANGLE (Degree)	RAW VALUE (dBuV)	CORRECTION FACTOR (dB/m)
1	#5715.00	58.4 PK	74.0	-15.6	2.03 H	9	52.48	5.92
2	#5715.00	43.5 AV	54.0	-10.5	2.03 H	9	37.58	5.92
3	#5725.00	70.7 PK	78.2	-7.5	2.03 H	9	64.79	5.91
4	*5745.00	111.1 PK			2.03 H	9	105.21	5.89
5	*5745.00	101.1 AV			2.03 H	9	95.21	5.89
6	11490.00	52.3 PK	74.0	-21.7	1.62 H	144	39.91	12.39
7	11490.00	42.8 AV	54.0	-11.2	1.62 H	144	30.41	12.39
8	#17235.00	57.2 PK	74.0	-16.8	1.41 H	142	36.21	20.99
9	#17235.00	44.7 AV	54.0	-9.3	1.41 H	142	23.71	20.99

**ANTENNA POLARITY & TEST DISTANCE: VERTICAL AT 3 M**

NO.	FREQ. (MHz)	EMISSION LEVEL (dBuV/m)	LIMIT (dBuV/m)	MARGIN (dB)	ANTENNA HEIGHT (m)	TABLE ANGLE (Degree)	RAW VALUE (dBuV)	CORRECTION FACTOR (dB/m)
1	#5715.00	53.6 PK	74.0	-20.4	1.32 V	127	47.68	5.92
2	#5715.00	39.8 AV	54.0	-14.2	1.32 V	127	33.88	5.92
3	#5725.00	65.5 PK	78.2	-12.7	1.32 V	127	59.59	5.91
4	*5745.00	106.3 PK			1.32 V	127	100.41	5.89
5	*5745.00	95.2 AV			1.32 V	127	89.31	5.89
6	11490.00	52.2 PK	74.0	-21.8	1.83 V	59	39.81	12.39
7	11490.00	43.3 AV	54.0	-10.7	1.83 V	59	30.91	12.39
8	#17235.00	56.7 PK	74.0	-17.3	1.78 V	79	35.71	20.99
9	#17235.00	44.3 AV	54.0	-9.7	1.78 V	79	23.31	20.99

**REMARKS:**

1. Emission Level(dBuV/m) = Raw Value(dBuV) + Correction Factor(dB/m)
2. Correction Factor(dB/m) = Antenna Factor(dB/m) + Cable Factor(dB) – Pre-Amplifier Factor(dB)
3. The other emission levels were very low against the limit.
4. Margin value = Emission Level – Limit value
5. " \* ": Fundamental frequency.
6. " # ": The radiated frequency is out of the restricted band.

<b>CHANNEL</b>	TX Channel 157	<b>DETECTOR FUNCTION</b>	Peak (PK)
<b>FREQUENCY RANGE</b>	1GHz ~ 25GHz		Average (AV)

**ANTENNA POLARITY & TEST DISTANCE: HORIZONTAL AT 3 M**

NO.	FREQ. (MHz)	EMISSION LEVEL (dBuV/m)	LIMIT (dBuV/m)	MARGIN (dB)	ANTENNA HEIGHT (m)	TABLE ANGLE (Degree)	RAW VALUE (dBuV)	CORRECTION FACTOR (dB/m)
1	#5705.00	57.1 PK	74.0	-16.9	1.93 H	10	51.17	5.93
2	#5705.00	47.5 AV	54.0	-6.5	1.93 H	10	41.57	5.93
3	*5785.00	110.8 PK			1.93 H	10	104.95	5.85
4	*5785.00	101.0 AV			1.93 H	10	95.15	5.85
5	11570.00	51.9 PK	74.0	-22.1	1.69 H	163	39.58	12.32
6	11570.00	42.9 AV	54.0	-11.1	1.69 H	163	30.58	12.32
7	#17355.00	57.2 PK	74.0	-16.8	1.49 H	138	35.93	21.27
8	#17355.00	44.9 AV	54.0	-9.1	1.49 H	138	23.63	21.27

**ANTENNA POLARITY & TEST DISTANCE: VERTICAL AT 3 M**

NO.	FREQ. (MHz)	EMISSION LEVEL (dBuV/m)	LIMIT (dBuV/m)	MARGIN (dB)	ANTENNA HEIGHT (m)	TABLE ANGLE (Degree)	RAW VALUE (dBuV)	CORRECTION FACTOR (dB/m)
1	#5705.00	52.0 PK	74.0	-22.0	1.36 V	151	46.07	5.93
2	#5705.00	42.3 AV	54.0	-11.7	1.36 V	151	36.37	5.93
3	*5785.00	105.9 PK			1.36 V	151	100.05	5.85
4	*5785.00	95.0 AV			1.36 V	151	89.15	5.85
5	11570.00	51.9 PK	74.0	-22.1	1.81 V	33	39.58	12.32
6	11570.00	43.3 AV	54.0	-10.7	1.81 V	33	30.98	12.32
7	#17355.00	57.5 PK	74.0	-16.5	1.73 V	80	36.23	21.27
8	#17355.00	44.9 AV	54.0	-9.1	1.73 V	80	23.63	21.27

**REMARKS:**

1. Emission Level(dBuV/m) = Raw Value(dBuV) + Correction Factor(dB/m)
2. Correction Factor(dB/m) = Antenna Factor(dB/m) + Cable Factor(dB) – Pre-Amplifier Factor(dB)
3. The other emission levels were very low against the limit.
4. Margin value = Emission Level – Limit value
5. " \* ": Fundamental frequency.
6. " # ": The radiated frequency is out of the restricted band.

<b>CHANNEL</b>	TX Channel 165	<b>DETECTOR FUNCTION</b>	Peak (PK)
<b>FREQUENCY RANGE</b>	1GHz ~ 25GHz		Average (AV)

**ANTENNA POLARITY & TEST DISTANCE: HORIZONTAL AT 3 M**

NO.	FREQ. (MHz)	EMISSION LEVEL (dBuV/m)	LIMIT (dBuV/m)	MARGIN (dB)	ANTENNA HEIGHT (m)	TABLE ANGLE (Degree)	RAW VALUE (dBuV)	CORRECTION FACTOR (dB/m)
1	*5825.00	110.7 PK			1.94 H	11	104.92	5.78
2	*5825.00	101.3 AV			1.94 H	11	95.52	5.78
3	#5850.00	57.6 PK	78.2	-20.6	1.94 H	11	51.87	5.73
4	#5860.00	55.1 PK	74.0	-18.9	1.94 H	11	49.40	5.70
5	#5860.00	41.8 AV	54.0	-12.2	1.94 H	11	36.10	5.70
6	11650.00	52.3 PK	74.0	-21.7	1.72 H	143	39.94	12.36
7	11650.00	42.8 AV	54.0	-11.2	1.72 H	143	30.44	12.36
8	#17475.00	56.9 PK	74.0	-17.1	1.51 H	145	35.73	21.17
9	#17475.00	44.5 AV	54.0	-9.5	1.51 H	145	23.33	21.17

**ANTENNA POLARITY & TEST DISTANCE: VERTICAL AT 3 M**

NO.	FREQ. (MHz)	EMISSION LEVEL (dBuV/m)	LIMIT (dBuV/m)	MARGIN (dB)	ANTENNA HEIGHT (m)	TABLE ANGLE (Degree)	RAW VALUE (dBuV)	CORRECTION FACTOR (dB/m)
1	*5825.00	106.1 PK			1.32 V	132	100.32	5.78
2	*5825.00	95.3 AV			1.32 V	132	89.52	5.78
3	#5850.00	53.8 PK	78.2	-24.4	1.32 V	132	48.07	5.73
4	#5860.00	52.1 PK	74.0	-21.9	1.32 V	132	46.40	5.70
5	#5860.00	39.6 AV	54.0	-14.4	1.32 V	132	33.90	5.70
6	11650.00	52.7 PK	74.0	-21.3	1.88 V	35	40.34	12.36
7	11650.00	43.7 AV	54.0	-10.3	1.88 V	35	31.34	12.36
8	#17475.00	57.1 PK	74.0	-16.9	1.78 V	71	35.93	21.17
9	#17475.00	44.4 AV	54.0	-9.6	1.78 V	71	23.23	21.17

**REMARKS:**

1. Emission Level(dBuV/m) = Raw Value(dBuV) + Correction Factor(dB/m)
2. Correction Factor(dB/m) = Antenna Factor(dB/m) + Cable Factor(dB) – Pre-Amplifier Factor(dB)
3. The other emission levels were very low against the limit.
4. Margin value = Emission Level – Limit value
5. " \* ": Fundamental frequency.
6. " # ": The radiated frequency is out of the restricted band.

**802.11ac (VHT40)**

<b>CHANNEL</b>	TX Channel 151	<b>DETECTOR FUNCTION</b>	Peak (PK)
<b>FREQUENCY RANGE</b>	1GHz ~ 25GHz		Average (AV)

<b>ANTENNA POLARITY &amp; TEST DISTANCE: HORIZONTAL AT 3 M</b>								
NO.	FREQ. (MHz)	EMISSION LEVEL (dBuV/m)	LIMIT (dBuV/m)	MARGIN (dB)	ANTENNA HEIGHT (m)	TABLE ANGLE (Degree)	RAW VALUE (dBuV)	CORRECTION FACTOR (dB/m)
1	#5715.00	66.8 PK	74.0	-7.2	1.92 H	12	60.88	5.92
2	#5715.00	52.6 AV	54.0	-1.4	1.92 H	12	46.68	5.92
3	#5725.00	69.4 PK	78.2	-8.8	1.92 H	12	63.49	5.91
4	*5755.00	106.6 PK			1.92 H	12	100.72	5.88
5	*5755.00	96.4 AV			1.92 H	12	90.52	5.88
6	11510.00	52.6 PK	74.0	-21.4	1.64 H	143	40.24	12.36
7	11510.00	43.2 AV	54.0	-10.8	1.64 H	143	30.84	12.36
8	#17265.00	56.6 PK	74.0	-17.4	1.50 H	157	35.81	20.79
9	#17265.00	44.3 AV	54.0	-9.7	1.50 H	157	23.51	20.79

<b>ANTENNA POLARITY &amp; TEST DISTANCE: VERTICAL AT 3 M</b>								
NO.	FREQ. (MHz)	EMISSION LEVEL (dBuV/m)	LIMIT (dBuV/m)	MARGIN (dB)	ANTENNA HEIGHT (m)	TABLE ANGLE (Degree)	RAW VALUE (dBuV)	CORRECTION FACTOR (dB/m)
1	#5715.00	61.6 PK	74.0	-12.4	1.32 V	134	55.68	5.92
2	#5715.00	48.1 AV	54.0	-5.9	1.32 V	134	42.18	5.92
3	#5725.00	64.1 PK	78.2	-14.1	1.32 V	134	58.19	5.91
4	*5755.00	102.1 PK			1.32 V	134	96.22	5.88
5	*5755.00	90.7 AV			1.32 V	134	84.82	5.88
6	11510.00	52.4 PK	74.0	-21.6	1.82 V	42	40.04	12.36
7	11510.00	43.7 AV	54.0	-10.3	1.82 V	42	31.34	12.36
8	#17265.00	56.9 PK	74.0	-17.1	1.80 V	78	36.11	20.79
9	#17265.00	44.3 AV	54.0	-9.7	1.80 V	78	23.51	20.79

**REMARKS:**

1. Emission Level(dBuV/m) = Raw Value(dBuV) + Correction Factor(dB/m)
2. Correction Factor(dB/m) = Antenna Factor(dB/m) + Cable Factor(dB) – Pre-Amplifier Factor(dB)
3. The other emission levels were very low against the limit.
4. Margin value = Emission Level – Limit value
5. " \* ": Fundamental frequency.
6. " # ": The radiated frequency is out of the restricted band.

<b>CHANNEL</b>	TX Channel 159	<b>DETECTOR FUNCTION</b>	Peak (PK)
<b>FREQUENCY RANGE</b>	1GHz ~ 25GHz		Average (AV)

**ANTENNA POLARITY & TEST DISTANCE: HORIZONTAL AT 3 M**

NO.	FREQ. (MHz)	EMISSION LEVEL (dBuV/m)	LIMIT (dBuV/m)	MARGIN (dB)	ANTENNA HEIGHT (m)	TABLE ANGLE (Degree)	RAW VALUE (dBuV)	CORRECTION FACTOR (dB/m)
1	*5795.00	110.8 PK			1.93 H	13	104.96	5.84
2	*5795.00	101.1 AV			1.93 H	13	95.26	5.84
3	#5850.00	66.1 PK	78.2	-12.1	1.93 H	13	60.37	5.73
4	#5860.00	64.2 PK	74.0	-9.8	1.93 H	13	58.50	5.70
5	#5860.00	47.9 AV	54.0	-6.1	1.93 H	13	42.20	5.70
6	11590.00	52.0 PK	74.0	-22.0	1.63 H	150	39.68	12.32
7	11590.00	42.4 AV	54.0	-11.6	1.63 H	150	30.08	12.32
8	#17385.00	56.7 PK	74.0	-17.3	1.47 H	139	35.07	21.63
9	#17385.00	44.4 AV	54.0	-9.6	1.47 H	139	22.77	21.63

**ANTENNA POLARITY & TEST DISTANCE: VERTICAL AT 3 M**

NO.	FREQ. (MHz)	EMISSION LEVEL (dBuV/m)	LIMIT (dBuV/m)	MARGIN (dB)	ANTENNA HEIGHT (m)	TABLE ANGLE (Degree)	RAW VALUE (dBuV)	CORRECTION FACTOR (dB/m)
1	*5795.00	106.4 PK			1.37 V	133	100.56	5.84
2	*5795.00	95.4 AV			1.37 V	133	89.56	5.84
3	#5850.00	60.8 PK	78.2	-17.4	1.37 V	133	55.07	5.73
4	#5860.00	58.5 PK	74.0	-15.5	1.37 V	133	52.80	5.70
5	#5860.00	42.6 AV	54.0	-11.4	1.37 V	133	36.90	5.70
6	11590.00	52.7 PK	74.0	-21.3	1.83 V	45	40.38	12.32
7	11590.00	43.5 AV	54.0	-10.5	1.83 V	45	31.18	12.32
8	#17385.00	56.5 PK	74.0	-17.5	1.71 V	55	34.87	21.63
9	#17385.00	44.1 AV	54.0	-9.9	1.71 V	55	22.47	21.63

**REMARKS:**

1. Emission Level(dBuV/m) = Raw Value(dBuV) + Correction Factor(dB/m)
2. Correction Factor(dB/m) = Antenna Factor(dB/m) + Cable Factor(dB) – Pre-Amplifier Factor(dB)
3. The other emission levels were very low against the limit.
4. Margin value = Emission Level – Limit value
5. " \* ": Fundamental frequency.
6. " # ": The radiated frequency is out of the restricted band.

**802.11ac (VHT80)**

<b>CHANNEL</b>	TX Channel 155	<b>DETECTOR FUNCTION</b>	Peak (PK)
<b>FREQUENCY RANGE</b>	1GHz ~ 25GHz		Average (AV)

<b>ANTENNA POLARITY &amp; TEST DISTANCE: HORIZONTAL AT 3 M</b>								
NO.	FREQ. (MHz)	EMISSION LEVEL (dBuV/m)	LIMIT (dBuV/m)	MARGIN (dB)	ANTENNA HEIGHT (m)	TABLE ANGLE (Degree)	RAW VALUE (dBuV)	CORRECTION FACTOR (dB/m)
1	#5715.00	66.2 PK	74.0	-7.8	1.95 H	11	60.28	5.92
2	#5715.00	<b>52.9 AV</b>	<b>54.0</b>	<b>-1.1</b>	<b>1.95 H</b>	<b>11</b>	<b>46.98</b>	<b>5.92</b>
3	#5725.00	67.6 PK	78.2	-10.6	1.95 H	11	61.69	5.91
4	*5775.00	109.1 PK			1.95 H	11	103.24	5.86
5	*5775.00	98.7 AV			1.95 H	11	92.84	5.86
6	#5850.00	62.6 PK	78.2	-15.6	1.95 H	11	56.87	5.73
7	#5860.00	59.5 PK	74.0	-14.5	1.95 H	11	53.80	5.70
8	#5860.00	45.2 AV	54.0	-8.8	1.95 H	11	39.50	5.70
9	11550.00	52.1 PK	74.0	-21.9	1.63 H	149	39.76	12.34
10	11550.00	42.8 AV	54.0	-11.2	1.63 H	149	30.46	12.34
11	#17325.00	57.1 PK	74.0	-16.9	1.42 H	134	36.21	20.89
12	#17325.00	44.6 AV	54.0	-9.4	1.42 H	134	23.71	20.89

<b>ANTENNA POLARITY &amp; TEST DISTANCE: VERTICAL AT 3 M</b>								
NO.	FREQ. (MHz)	EMISSION LEVEL (dBuV/m)	LIMIT (dBuV/m)	MARGIN (dB)	ANTENNA HEIGHT (m)	TABLE ANGLE (Degree)	RAW VALUE (dBuV)	CORRECTION FACTOR (dB/m)
1	#5715.00	61.1 PK	74.0	-12.9	1.34 V	132	55.18	5.92
2	#5715.00	49.1 AV	54.0	-4.9	1.34 V	132	43.18	5.92
3	#5725.00	62.5 PK	78.2	-15.7	1.34 V	132	56.59	5.91
4	*5775.00	104.7 PK			1.34 V	132	98.84	5.86
5	*5775.00	93.1 AV			1.34 V	132	87.24	5.86
6	#5850.00	58.1 PK	78.2	-20.1	1.34 V	132	52.37	5.73
7	#5860.00	55.4 PK	74.0	-18.6	1.34 V	132	49.70	5.70
8	#5860.00	40.6 AV	54.0	-13.4	1.34 V	132	34.90	5.70
9	11550.00	51.8 PK	74.0	-22.2	1.89 V	52	39.46	12.34
10	11550.00	42.9 AV	54.0	-11.1	1.89 V	52	30.56	12.34
11	#17325.00	56.2 PK	74.0	-17.8	1.72 V	79	35.31	20.89
12	#17325.00	44.1 AV	54.0	-9.9	1.72 V	79	23.21	20.89

**REMARKS:**

- Emission Level(dBuV/m) = Raw Value(dBuV) + Correction Factor(dB/m)
- Correction Factor(dB/m) = Antenna Factor(dB/m) + Cable Factor(dB) – Pre-Amplifier Factor(dB)
- The other emission levels were very low against the limit.
- Margin value = Emission Level – Limit value
- " \* ": Fundamental frequency.
- " # ": The radiated frequency is out of the restricted band.

**Below 1GHz Data**
**802.11ac (VHT20)**

<b>CHANNEL</b>	TX Channel 165	<b>DETECTOR FUNCTION</b>	Quasi-Peak (QP)
<b>FREQUENCY RANGE</b>	Below 1GHz		

**ANTENNA POLARITY & TEST DISTANCE: HORIZONTAL AT 3 M**

NO.	FREQ. (MHz)	EMISSION LEVEL (dBuV/m)	LIMIT (dBuV/m)	MARGIN (dB)	ANTENNA HEIGHT (m)	TABLE ANGLE (Degree)	RAW VALUE (dBuV)	CORRECTION FACTOR (dB/m)
1	165.85	40.4 QP	43.5	-3.1	2.00 H	79	55.88	-15.49
2	199.31	39.4 QP	43.5	-4.1	1.50 H	202	57.70	-18.34
3	232.24	40.1 QP	46.0	-5.9	1.50 H	267	57.37	-17.24
4	431.83	37.1 QP	46.0	-8.9	2.00 H	157	47.69	-10.55
5	498.71	38.2 QP	46.0	-7.8	1.50 H	23	47.52	-9.34
6	709.70	39.2 QP	46.0	-6.8	1.00 H	64	44.59	-5.43

**ANTENNA POLARITY & TEST DISTANCE: VERTICAL AT 3 M**

NO.	FREQ. (MHz)	EMISSION LEVEL (dBuV/m)	LIMIT (dBuV/m)	MARGIN (dB)	ANTENNA HEIGHT (m)	TABLE ANGLE (Degree)	RAW VALUE (dBuV)	CORRECTION FACTOR (dB/m)
1	166.19	35.5 QP	43.5	-8.0	1.00 V	170	51.04	-15.52
2	199.08	32.2 QP	43.5	-11.3	1.50 V	130	50.51	-18.34
3	432.15	33.2 QP	46.0	-12.8	1.00 V	219	43.73	-10.53
4	498.81	36.2 QP	46.0	-9.8	1.50 V	79	45.50	-9.33
5	598.15	33.3 QP	46.0	-12.7	1.00 V	135	40.10	-6.83
6	696.82	35.3 QP	46.0	-10.7	2.00 V	277	40.84	-5.54

**REMARKS:**

1. Emission Level(dBuV/m) = Raw Value(dBuV) + Correction Factor(dB/m)
2. Correction Factor(dB/m) = Antenna Factor(dB/m) + Cable Factor(dB) – Pre-Amplifier Factor(dB)
3. The other emission levels were very low against the limit.
4. Margin value = Emission Level – Limit value

## 4.1.8 Test Results (Mode 2)

## Above 1GHz Data

## 802.11a

<b>CHANNEL</b>	TX Channel 149	<b>DETECTOR FUNCTION</b>	Peak (PK)
<b>FREQUENCY RANGE</b>	1GHz ~ 25GHz		Average (AV)

**ANTENNA POLARITY & TEST DISTANCE: HORIZONTAL AT 3 M**

NO.	FREQ. (MHz)	EMISSION LEVEL (dBuV/m)	LIMIT (dBuV/m)	MARGIN (dB)	ANTENNA HEIGHT (m)	TABLE ANGLE (Degree)	RAW VALUE (dBuV)	CORRECTION FACTOR (dB/m)
1	#5715.00	53.2 PK	74.0	-20.8	1.08 H	238	47.28	5.92
2	#5715.00	39.6 AV	54.0	-14.4	1.08 H	238	33.68	5.92
3	#5725.00	60.1 PK	78.2	-18.1	1.08 H	238	54.19	5.91
4	*5745.00	101.7 PK			1.08 H	238	95.81	5.89
5	*5745.00	93.5 AV			1.08 H	238	87.61	5.89
6	11490.00	52.4 PK	74.0	-21.6	1.62 H	154	40.01	12.39
7	11490.00	43.1 AV	54.0	-10.9	1.62 H	154	30.71	12.39
8	#17235.00	55.9 PK	74.0	-18.1	1.48 H	142	34.91	20.99
9	#17235.00	43.8 AV	54.0	-10.2	1.48 H	142	22.81	20.99

**ANTENNA POLARITY & TEST DISTANCE: VERTICAL AT 3 M**

NO.	FREQ. (MHz)	EMISSION LEVEL (dBuV/m)	LIMIT (dBuV/m)	MARGIN (dB)	ANTENNA HEIGHT (m)	TABLE ANGLE (Degree)	RAW VALUE (dBuV)	CORRECTION FACTOR (dB/m)
1	#5715.00	64.4 PK	74.0	-9.6	2.20 V	308	58.48	5.92
2	#5715.00	47.9 AV	54.0	-6.1	2.20 V	308	41.98	5.92
3	#5725.00	75.4 PK	78.2	-2.8	2.20 V	308	69.49	5.91
4	*5745.00	115.4 PK			2.20 V	308	109.51	5.89
5	*5745.00	106.8 AV			2.20 V	308	100.91	5.89
6	11490.00	52.8 PK	74.0	-21.2	1.81 V	35	40.41	12.39
7	11490.00	43.7 AV	54.0	-10.3	1.81 V	35	31.31	12.39
8	#17235.00	57.1 PK	74.0	-16.9	1.73 V	79	36.11	20.99
9	#17235.00	45.1 AV	54.0	-8.9	1.73 V	79	24.11	20.99

**REMARKS:**

1. Emission Level(dBuV/m) = Raw Value(dBuV) + Correction Factor(dB/m)
2. Correction Factor(dB/m) = Antenna Factor(dB/m) + Cable Factor(dB) – Pre-Amplifier Factor(dB)
3. The other emission levels were very low against the limit.
4. Margin value = Emission Level – Limit value
5. " \* ": Fundamental frequency.
6. " # ": The radiated frequency is out of the restricted band.



<b>CHANNEL</b>	TX Channel 157	<b>DETECTOR FUNCTION</b>	Peak (PK)
<b>FREQUENCY RANGE</b>	1GHz ~ 25GHz		Average (AV)

**ANTENNA POLARITY & TEST DISTANCE: HORIZONTAL AT 3 M**

NO.	FREQ. (MHz)	EMISSION LEVEL (dBuV/m)	LIMIT (dBuV/m)	MARGIN (dB)	ANTENNA HEIGHT (m)	TABLE ANGLE (Degree)	RAW VALUE (dBuV)	CORRECTION FACTOR (dB/m)
1	#5700.00	53.8 PK	74.0	-20.2	1.02 H	245	47.86	5.94
2	#5700.00	40.3 AV	54.0	-13.7	1.02 H	245	34.36	5.94
3	*5785.00	102.9 PK			1.02 H	245	97.05	5.85
4	*5785.00	94.0 AV			1.02 H	245	88.15	5.85
5	#5860.00	53.1 PK	74.0	-20.9	1.02 H	245	47.40	5.70
6	#5860.00	39.9 AV	54.0	-14.1	1.02 H	245	34.20	5.70
7	11570.00	52.2 PK	74.0	-21.8	1.63 H	154	39.88	12.32
8	11570.00	42.9 AV	54.0	-11.1	1.63 H	154	30.58	12.32
9	#17355.00	56.2 PK	74.0	-17.8	1.46 H	137	34.93	21.27
10	#17355.00	44.0 AV	54.0	-10.0	1.46 H	137	22.73	21.27

**ANTENNA POLARITY & TEST DISTANCE: VERTICAL AT 3 M**

NO.	FREQ. (MHz)	EMISSION LEVEL (dBuV/m)	LIMIT (dBuV/m)	MARGIN (dB)	ANTENNA HEIGHT (m)	TABLE ANGLE (Degree)	RAW VALUE (dBuV)	CORRECTION FACTOR (dB/m)
1	#5700.00	59.4 PK	74.0	-14.6	2.26 V	304	53.46	5.94
2	#5700.00	46.4 AV	54.0	-7.6	2.26 V	304	40.46	5.94
3	*5785.00	116.6 PK			2.26 V	304	110.75	5.85
4	*5785.00	107.2 AV			2.26 V	304	101.35	5.85
5	#5860.00	57.9 PK	74.0	-16.1	2.26 V	304	52.20	5.70
6	#5860.00	46.6 AV	54.0	-7.4	2.26 V	304	40.90	5.70
7	11570.00	52.2 PK	74.0	-21.8	1.74 V	45	39.88	12.32
8	11570.00	43.0 AV	54.0	-11.0	1.74 V	45	30.68	12.32
9	#17355.00	56.9 PK	74.0	-17.1	1.75 V	55	35.63	21.27
10	#17355.00	44.9 AV	54.0	-9.1	1.75 V	55	23.63	21.27

**REMARKS:**

1. Emission Level(dBuV/m) = Raw Value(dBuV) + Correction Factor(dB/m)
2. Correction Factor(dB/m) = Antenna Factor(dB/m) + Cable Factor(dB) – Pre-Amplifier Factor(dB)
3. The other emission levels were very low against the limit.
4. Margin value = Emission Level – Limit value
5. " \* ": Fundamental frequency.
6. " # ": The radiated frequency is out of the restricted band.

<b>CHANNEL</b>	TX Channel 165	<b>DETECTOR FUNCTION</b>	Peak (PK)
<b>FREQUENCY RANGE</b>	1GHz ~ 25GHz		Average (AV)

**ANTENNA POLARITY & TEST DISTANCE: HORIZONTAL AT 3 M**

NO.	FREQ. (MHz)	EMISSION LEVEL (dBuV/m)	LIMIT (dBuV/m)	MARGIN (dB)	ANTENNA HEIGHT (m)	TABLE ANGLE (Degree)	RAW VALUE (dBuV)	CORRECTION FACTOR (dB/m)
1	*5825.00	102.7 PK			1.00 H	233	96.92	5.78
2	*5825.00	93.7 AV			1.00 H	233	87.92	5.78
3	#5850.00	58.1 PK	78.2	-20.1	1.00 H	233	52.37	5.73
4	#5860.00	53.8 PK	74.0	-20.2	1.00 H	233	48.10	5.70
5	#5860.00	40.1 AV	54.0	-13.9	1.00 H	233	34.40	5.70
6	11650.00	52.1 PK	74.0	-21.9	1.60 H	155	39.74	12.36
7	11650.00	42.9 AV	54.0	-11.1	1.60 H	155	30.54	12.36
8	#17475.00	56.5 PK	74.0	-17.5	1.48 H	129	35.33	21.17
9	#17475.00	44.2 AV	54.0	-9.8	1.48 H	129	23.03	21.17

**ANTENNA POLARITY & TEST DISTANCE: VERTICAL AT 3 M**

NO.	FREQ. (MHz)	EMISSION LEVEL (dBuV/m)	LIMIT (dBuV/m)	MARGIN (dB)	ANTENNA HEIGHT (m)	TABLE ANGLE (Degree)	RAW VALUE (dBuV)	CORRECTION FACTOR (dB/m)
1	*5825.00	116.5 PK			2.30 V	300	110.72	5.78
2	*5825.00	106.9 AV			2.30 V	300	101.12	5.78
3	#5850.00	73.9 PK	78.2	-4.3	2.30 V	300	68.17	5.73
4	#5860.00	66.9 PK	74.0	-7.1	2.30 V	300	61.20	5.70
5	#5860.00	51.5 AV	54.0	-2.5	2.30 V	300	45.80	5.70
6	11650.00	52.4 PK	74.0	-21.6	1.80 V	47	40.04	12.36
7	11650.00	43.2 AV	54.0	-10.8	1.80 V	47	30.84	12.36
8	#17475.00	56.9 PK	74.0	-17.1	1.77 V	68	35.73	21.17
9	#17475.00	44.6 AV	54.0	-9.4	1.77 V	68	23.43	21.17

**REMARKS:**

1. Emission Level(dBuV/m) = Raw Value(dBuV) + Correction Factor(dB/m)
2. Correction Factor(dB/m) = Antenna Factor(dB/m) + Cable Factor(dB) – Pre-Amplifier Factor(dB)
3. The other emission levels were very low against the limit.
4. Margin value = Emission Level – Limit value
5. " \* ": Fundamental frequency.
6. " # ": The radiated frequency is out of the restricted band.

**802.11ac (VHT20)**

<b>CHANNEL</b>	TX Channel 149	<b>DETECTOR FUNCTION</b>	Peak (PK)
<b>FREQUENCY RANGE</b>	1GHz ~ 25GHz		Average (AV)

**ANTENNA POLARITY & TEST DISTANCE: HORIZONTAL AT 3 M**

NO.	FREQ. (MHz)	EMISSION LEVEL (dBuV/m)	LIMIT (dBuV/m)	MARGIN (dB)	ANTENNA HEIGHT (m)	TABLE ANGLE (Degree)	RAW VALUE (dBuV)	CORRECTION FACTOR (dB/m)
1	#5715.00	52.8 PK	74.0	-21.2	1.00 H	235	46.88	5.92
2	#5715.00	39.7 AV	54.0	-14.3	1.00 H	235	33.78	5.92
3	#5725.00	62.2 PK	78.2	-16.0	1.00 H	235	56.29	5.91
4	*5745.00	99.4 PK			1.00 H	235	93.51	5.89
5	*5745.00	91.3 AV			1.00 H	235	85.41	5.89
6	11490.00	52.5 PK	74.0	-21.5	1.58 H	159	40.11	12.39
7	11490.00	43.2 AV	54.0	-10.8	1.58 H	159	30.81	12.39
8	#17235.00	56.8 PK	74.0	-17.2	1.49 H	130	35.81	20.99
9	#17235.00	44.6 AV	54.0	-9.4	1.49 H	130	23.61	20.99

**ANTENNA POLARITY & TEST DISTANCE: VERTICAL AT 3 M**

NO.	FREQ. (MHz)	EMISSION LEVEL (dBuV/m)	LIMIT (dBuV/m)	MARGIN (dB)	ANTENNA HEIGHT (m)	TABLE ANGLE (Degree)	RAW VALUE (dBuV)	CORRECTION FACTOR (dB/m)
1	#5715.00	59.9 PK	74.0	-14.1	2.24 V	308	53.98	5.92
2	#5715.00	45.5 AV	54.0	-8.5	2.24 V	308	39.58	5.92
3	#5725.00	77.0 PK	78.2	-1.2	2.24 V	308	71.09	5.91
4	*5745.00	113.2 PK			2.24 V	308	107.31	5.89
5	*5745.00	104.5 AV			2.24 V	308	98.61	5.89
6	11490.00	51.9 PK	74.0	-22.1	1.78 V	41	39.51	12.39
7	11490.00	42.9 AV	54.0	-11.1	1.78 V	41	30.51	12.39
8	#17235.00	57.2 PK	74.0	-16.8	1.79 V	67	36.21	20.99
9	#17235.00	44.6 AV	54.0	-9.4	1.79 V	67	23.61	20.99

**REMARKS:**

1. Emission Level(dBuV/m) = Raw Value(dBuV) + Correction Factor(dB/m)
2. Correction Factor(dB/m) = Antenna Factor(dB/m) + Cable Factor(dB) – Pre-Amplifier Factor(dB)
3. The other emission levels were very low against the limit.
4. Margin value = Emission Level – Limit value
5. " \* ": Fundamental frequency.
6. " # ": The radiated frequency is out of the restricted band.

<b>CHANNEL</b>	TX Channel 157	<b>DETECTOR FUNCTION</b>	Peak (PK)
<b>FREQUENCY RANGE</b>	1GHz ~ 25GHz		Average (AV)

**ANTENNA POLARITY & TEST DISTANCE: HORIZONTAL AT 3 M**

NO.	FREQ. (MHz)	EMISSION LEVEL (dBuV/m)	LIMIT (dBuV/m)	MARGIN (dB)	ANTENNA HEIGHT (m)	TABLE ANGLE (Degree)	RAW VALUE (dBuV)	CORRECTION FACTOR (dB/m)
1	#5710.00	52.4 PK	74.0	-21.6	1.10 H	233	46.47	5.93
2	#5710.00	39.5 AV	54.0	-14.5	1.10 H	233	33.57	5.93
3	*5785.00	101.1 PK			1.10 H	233	95.25	5.85
4	*5785.00	92.2 AV			1.10 H	233	86.35	5.85
5	#5860.00	53.1 PK	74.0	-20.9	1.10 H	233	47.40	5.70
6	#5860.00	41.1 AV	54.0	-12.9	1.10 H	233	35.40	5.70
7	11570.00	51.8 PK	74.0	-22.2	1.58 H	144	39.48	12.32
8	11570.00	42.6 AV	54.0	-11.4	1.58 H	144	30.28	12.32
9	#17355.00	56.7 PK	74.0	-17.3	1.46 H	134	35.43	21.27
10	#17355.00	44.1 AV	54.0	-9.9	1.46 H	134	22.83	21.27

**ANTENNA POLARITY & TEST DISTANCE: VERTICAL AT 3 M**

NO.	FREQ. (MHz)	EMISSION LEVEL (dBuV/m)	LIMIT (dBuV/m)	MARGIN (dB)	ANTENNA HEIGHT (m)	TABLE ANGLE (Degree)	RAW VALUE (dBuV)	CORRECTION FACTOR (dB/m)
1	#5710.00	58.8 PK	74.0	-15.2	2.28 V	307	52.87	5.93
2	#5710.00	46.4 AV	54.0	-7.6	2.28 V	307	40.47	5.93
3	*5785.00	114.8 PK			2.28 V	307	108.95	5.85
4	*5785.00	105.3 AV			2.28 V	307	99.45	5.85
5	#5860.00	59.5 PK	74.0	-14.5	2.28 V	307	53.80	5.70
6	#5860.00	48.4 AV	54.0	-5.6	2.28 V	307	42.70	5.70
7	11570.00	52.2 PK	74.0	-21.8	1.85 V	56	39.88	12.32
8	11570.00	43.1 AV	54.0	-10.9	1.85 V	56	30.78	12.32
9	#17355.00	56.9 PK	74.0	-17.1	1.81 V	82	35.63	21.27
10	#17355.00	44.4 AV	54.0	-9.6	1.81 V	82	23.13	21.27

**REMARKS:**

1. Emission Level(dBuV/m) = Raw Value(dBuV) + Correction Factor(dB/m)
2. Correction Factor(dB/m) = Antenna Factor(dB/m) + Cable Factor(dB) – Pre-Amplifier Factor(dB)
3. The other emission levels were very low against the limit.
4. Margin value = Emission Level – Limit value
5. " \* ": Fundamental frequency.
6. " # ": The radiated frequency is out of the restricted band.

<b>CHANNEL</b>	TX Channel 165	<b>DETECTOR FUNCTION</b>	Peak (PK)
<b>FREQUENCY RANGE</b>	1GHz ~ 25GHz		Average (AV)

**ANTENNA POLARITY & TEST DISTANCE: HORIZONTAL AT 3 M**

NO.	FREQ. (MHz)	EMISSION LEVEL (dBuV/m)	LIMIT (dBuV/m)	MARGIN (dB)	ANTENNA HEIGHT (m)	TABLE ANGLE (Degree)	RAW VALUE (dBuV)	CORRECTION FACTOR (dB/m)
1	*5825.00	100.9 PK			1.05 H	237	95.12	5.78
2	*5825.00	92.1 AV			1.05 H	237	86.32	5.78
3	#5850.00	56.8 PK	78.2	-21.4	1.05 H	237	51.07	5.73
4	#5860.00	53.2 PK	74.0	-20.8	1.05 H	237	47.50	5.70
5	#5860.00	39.8 AV	54.0	-14.2	1.05 H	237	34.10	5.70
6	11650.00	51.7 PK	74.0	-22.3	1.60 H	153	39.34	12.36
7	11650.00	42.5 AV	54.0	-11.5	1.60 H	153	30.14	12.36
8	#17475.00	56.6 PK	74.0	-17.4	1.42 H	119	35.43	21.17
9	#17475.00	44.5 AV	54.0	-9.5	1.42 H	119	23.33	21.17

**ANTENNA POLARITY & TEST DISTANCE: VERTICAL AT 3 M**

NO.	FREQ. (MHz)	EMISSION LEVEL (dBuV/m)	LIMIT (dBuV/m)	MARGIN (dB)	ANTENNA HEIGHT (m)	TABLE ANGLE (Degree)	RAW VALUE (dBuV)	CORRECTION FACTOR (dB/m)
1	*5825.00	114.6 PK			2.28 V	306	108.82	5.78
2	*5825.00	105.2 AV			2.28 V	306	99.42	5.78
3	#5850.00	72.0 PK	78.2	-6.2	2.28 V	306	66.27	5.73
4	#5860.00	65.2 PK	74.0	-8.8	2.28 V	306	59.50	5.70
5	#5860.00	47.0 AV	54.0	-7.0	2.28 V	306	41.30	5.70
6	11650.00	52.8 PK	74.0	-21.2	1.77 V	52	40.44	12.36
7	11650.00	43.5 AV	54.0	-10.5	1.77 V	52	31.14	12.36
8	#17475.00	56.9 PK	74.0	-17.1	1.82 V	78	35.73	21.17
9	#17475.00	44.6 AV	54.0	-9.4	1.82 V	78	23.43	21.17

**REMARKS:**

1. Emission Level(dBuV/m) = Raw Value(dBuV) + Correction Factor(dB/m)
2. Correction Factor(dB/m) = Antenna Factor(dB/m) + Cable Factor(dB) – Pre-Amplifier Factor(dB)
3. The other emission levels were very low against the limit.
4. Margin value = Emission Level – Limit value
5. " \* ": Fundamental frequency.
6. " # ": The radiated frequency is out of the restricted band.

**802.11ac (VHT40)**

<b>CHANNEL</b>	TX Channel 151	<b>DETECTOR FUNCTION</b>	Peak (PK)
<b>FREQUENCY RANGE</b>	1GHz ~ 25GHz		Average (AV)

**ANTENNA POLARITY & TEST DISTANCE: HORIZONTAL AT 3 M**

NO.	FREQ. (MHz)	EMISSION LEVEL (dBuV/m)	LIMIT (dBuV/m)	MARGIN (dB)	ANTENNA HEIGHT (m)	TABLE ANGLE (Degree)	RAW VALUE (dBuV)	CORRECTION FACTOR (dB/m)
1	#5715.00	53.2 PK	74.0	-20.8	1.04 H	247	47.28	5.92
2	#5715.00	41.8 AV	54.0	-12.2	1.04 H	247	35.88	5.92
3	#5725.00	55.6 PK	78.2	-22.6	1.04 H	247	49.69	5.91
4	*5755.00	93.9 PK			1.04 H	247	88.02	5.88
5	*5755.00	84.2 AV			1.04 H	247	78.32	5.88
6	11510.00	52.5 PK	74.0	-21.5	1.56 H	171	40.14	12.36
7	11510.00	43.1 AV	54.0	-10.9	1.56 H	171	30.74	12.36
8	#17265.00	56.8 PK	74.0	-17.2	1.54 H	118	36.01	20.79
9	#17265.00	44.7 AV	54.0	-9.3	1.54 H	118	23.91	20.79

**ANTENNA POLARITY & TEST DISTANCE: VERTICAL AT 3 M**

NO.	FREQ. (MHz)	EMISSION LEVEL (dBuV/m)	LIMIT (dBuV/m)	MARGIN (dB)	ANTENNA HEIGHT (m)	TABLE ANGLE (Degree)	RAW VALUE (dBuV)	CORRECTION FACTOR (dB/m)
1	#5715.00	66.7 PK	74.0	-7.3	2.31 V	306	60.78	5.92
2	#5715.00	52.6 AV	54.0	-1.4	2.31 V	306	46.68	5.92
3	#5725.00	70.2 PK	78.2	-8.0	2.31 V	306	64.29	5.91
4	*5755.00	107.6 PK			2.31 V	306	101.72	5.88
5	*5755.00	97.2 AV			2.31 V	306	91.32	5.88
6	11510.00	51.7 PK	74.0	-22.3	1.77 V	62	39.34	12.36
7	11510.00	42.7 AV	54.0	-11.3	1.77 V	62	30.34	12.36
8	#17265.00	56.8 PK	74.0	-17.2	1.78 V	71	36.01	20.79
9	#17265.00	44.7 AV	54.0	-9.3	1.78 V	71	23.91	20.79

**REMARKS:**

1. Emission Level(dBuV/m) = Raw Value(dBuV) + Correction Factor(dB/m)
2. Correction Factor(dB/m) = Antenna Factor(dB/m) + Cable Factor(dB) – Pre-Amplifier Factor(dB)
3. The other emission levels were very low against the limit.
4. Margin value = Emission Level – Limit value
5. " \* ": Fundamental frequency.
6. " # ": The radiated frequency is out of the restricted band.

<b>CHANNEL</b>	TX Channel 159	<b>DETECTOR FUNCTION</b>	Peak (PK)
<b>FREQUENCY RANGE</b>	1GHz ~ 25GHz		Average (AV)

**ANTENNA POLARITY & TEST DISTANCE: HORIZONTAL AT 3 M**

NO.	FREQ. (MHz)	EMISSION LEVEL (dBuV/m)	LIMIT (dBuV/m)	MARGIN (dB)	ANTENNA HEIGHT (m)	TABLE ANGLE (Degree)	RAW VALUE (dBuV)	CORRECTION FACTOR (dB/m)
1	*5795.00	99.7 PK			1.04 H	248	93.86	5.84
2	*5795.00	90.5 AV			1.04 H	248	84.66	5.84
3	#5850.00	58.6 PK	78.2	-19.6	1.04 H	248	52.87	5.73
4	#5860.00	56.1 PK	74.0	-17.9	1.04 H	248	50.40	5.70
5	#5860.00	41.6 AV	54.0	-12.4	1.04 H	248	35.90	5.70
6	11590.00	52.7 PK	74.0	-21.3	1.60 H	169	40.38	12.32
7	11590.00	43.2 AV	54.0	-10.8	1.60 H	169	30.88	12.32
8	#17385.00	56.9 PK	74.0	-17.1	1.49 H	127	35.27	21.63
9	#17385.00	44.3 AV	54.0	-9.7	1.49 H	127	22.67	21.63

**ANTENNA POLARITY & TEST DISTANCE: VERTICAL AT 3 M**

NO.	FREQ. (MHz)	EMISSION LEVEL (dBuV/m)	LIMIT (dBuV/m)	MARGIN (dB)	ANTENNA HEIGHT (m)	TABLE ANGLE (Degree)	RAW VALUE (dBuV)	CORRECTION FACTOR (dB/m)
1	*5795.00	113.3 PK			2.32 V	305	107.46	5.84
2	*5795.00	103.0 AV			2.32 V	305	97.16	5.84
3	#5850.00	69.8 PK	78.2	-8.4	2.32 V	305	64.07	5.73
4	#5860.00	67.3 PK	74.0	-6.7	2.32 V	305	61.60	5.70
5	#5860.00	51.0 AV	54.0	-3.0	2.32 V	305	45.30	5.70
6	11590.00	52.0 PK	74.0	-22.0	1.76 V	39	39.68	12.32
7	11590.00	42.8 AV	54.0	-11.2	1.76 V	39	30.48	12.32
8	#17385.00	56.5 PK	74.0	-17.5	1.79 V	69	34.87	21.63
9	#17385.00	44.2 AV	54.0	-9.8	1.79 V	69	22.57	21.63

**REMARKS:**

1. Emission Level(dBuV/m) = Raw Value(dBuV) + Correction Factor(dB/m)
2. Correction Factor(dB/m) = Antenna Factor(dB/m) + Cable Factor(dB) – Pre-Amplifier Factor(dB)
3. The other emission levels were very low against the limit.
4. Margin value = Emission Level – Limit value
5. " \* ": Fundamental frequency.
6. " # ": The radiated frequency is out of the restricted band.

**802.11ac (VHT80)**

<b>CHANNEL</b>	TX Channel 155	<b>DETECTOR FUNCTION</b>	Peak (PK)
<b>FREQUENCY RANGE</b>	1GHz ~ 25GHz		Average (AV)

<b>ANTENNA POLARITY &amp; TEST DISTANCE: HORIZONTAL AT 3 M</b>								
NO.	FREQ. (MHz)	EMISSION LEVEL (dBuV/m)	LIMIT (dBuV/m)	MARGIN (dB)	ANTENNA HEIGHT (m)	TABLE ANGLE (Degree)	RAW VALUE (dBuV)	CORRECTION FACTOR (dB/m)
1	#5715.00	53.8 PK	74.0	-20.2	1.16 H	226	47.88	5.92
2	#5715.00	42.2 AV	54.0	-11.8	1.16 H	226	36.28	5.92
3	#5725.00	56.1 PK	78.2	-22.1	1.16 H	226	50.19	5.91
4	*5775.00	90.6 PK			1.16 H	226	84.74	5.86
5	*5775.00	81.4 AV			1.16 H	226	75.54	5.86
6	#5850.00	54.4 PK	78.2	-23.8	1.16 H	226	48.67	5.73
7	#5860.00	52.8 PK	74.0	-21.2	1.16 H	226	47.10	5.70
8	#5860.00	39.1 AV	54.0	-14.9	1.16 H	226	33.40	5.70
9	11550.00	51.4 PK	74.0	-22.6	1.65 H	164	39.06	12.34
10	11550.00	42.4 AV	54.0	-11.6	1.65 H	164	30.06	12.34
11	#17325.00	56.4 PK	74.0	-17.6	1.53 H	128	35.51	20.89
12	#17325.00	44.3 AV	54.0	-9.7	1.53 H	128	23.41	20.89

<b>ANTENNA POLARITY &amp; TEST DISTANCE: VERTICAL AT 3 M</b>								
NO.	FREQ. (MHz)	EMISSION LEVEL (dBuV/m)	LIMIT (dBuV/m)	MARGIN (dB)	ANTENNA HEIGHT (m)	TABLE ANGLE (Degree)	RAW VALUE (dBuV)	CORRECTION FACTOR (dB/m)
1	#5715.00	66.0 PK	74.0	-8.0	2.33 V	304	60.08	5.92
2	#5715.00	52.5 AV	54.0	-1.5	2.33 V	304	46.58	5.92
3	#5725.00	67.2 PK	78.2	-11.0	2.33 V	304	61.29	5.91
4	*5775.00	104.2 PK			2.33 V	304	98.34	5.86
5	*5775.00	93.9 AV			2.33 V	304	88.04	5.86
6	#5850.00	64.4 PK	78.2	-13.8	2.33 V	304	58.67	5.73
7	#5860.00	60.8 PK	74.0	-13.2	2.33 V	304	55.10	5.70
8	#5860.00	46.4 AV	54.0	-7.6	2.33 V	304	40.70	5.70
9	11550.00	52.6 PK	74.0	-21.4	1.76 V	54	40.26	12.34
10	11550.00	43.6 AV	54.0	-10.4	1.76 V	54	31.26	12.34
11	#17325.00	57.5 PK	74.0	-16.5	1.72 V	52	36.61	20.89
12	#17325.00	45.0 AV	54.0	-9.0	1.72 V	52	24.11	20.89

**REMARKS:**

1. Emission Level(dBuV/m) = Raw Value(dBuV) + Correction Factor(dB/m)
2. Correction Factor(dB/m) = Antenna Factor(dB/m) + Cable Factor(dB) – Pre-Amplifier Factor(dB)
3. The other emission levels were very low against the limit.
4. Margin value = Emission Level – Limit value
5. " \* ": Fundamental frequency.
6. " # ": The radiated frequency is out of the restricted band.



**Below 1GHz Data**

**802.11ac (VHT20)**

<b>CHANNEL</b>	TX Channel 165	<b>DETECTOR FUNCTION</b>	Quasi-Peak (QP)
<b>FREQUENCY RANGE</b>	Below 1GHz		

**ANTENNA POLARITY & TEST DISTANCE: HORIZONTAL AT 3 M**

NO.	FREQ. (MHz)	EMISSION LEVEL (dBuV/m)	LIMIT (dBuV/m)	MARGIN (dB)	ANTENNA HEIGHT (m)	TABLE ANGLE (Degree)	RAW VALUE (dBuV)	CORRECTION FACTOR (dB/m)
1	165.99	40.5 QP	43.5	-3.0	2.00 H	60	55.99	-15.51
2	199.19	39.3 QP	43.5	-4.2	1.50 H	214	57.63	-18.34
3	232.39	40.2 QP	46.0	-5.8	1.50 H	252	57.41	-17.23
4	431.99	37.3 QP	46.0	-8.8	2.00 H	172	47.79	-10.54
5	498.85	38.3 QP	46.0	-7.7	1.50 H	32	47.61	-9.33
6	709.82	39.0 QP	46.0	-7.0	1.00 H	49	44.47	-5.43

**ANTENNA POLARITY & TEST DISTANCE: VERTICAL AT 3 M**

NO.	FREQ. (MHz)	EMISSION LEVEL (dBuV/m)	LIMIT (dBuV/m)	MARGIN (dB)	ANTENNA HEIGHT (m)	TABLE ANGLE (Degree)	RAW VALUE (dBuV)	CORRECTION FACTOR (dB/m)
1	166.28	35.7 QP	43.5	-7.9	1.00 V	181	51.18	-15.53
2	199.19	32.1 QP	43.5	-11.4	1.50 V	140	50.41	-18.34
3	432.02	33.1 QP	46.0	-12.9	1.00 V	232	43.65	-10.54
4	498.90	36.1 QP	46.0	-9.9	1.50 V	65	45.39	-9.33
5	598.20	33.1 QP	46.0	-12.9	1.00 V	122	39.94	-6.82
6	696.97	35.4 QP	46.0	-10.6	2.00 V	292	40.93	-5.53

**REMARKS:**

1. Emission Level(dBuV/m) = Raw Value(dBuV) + Correction Factor(dB/m)
2. Correction Factor(dB/m) = Antenna Factor(dB/m) + Cable Factor(dB) – Pre-Amplifier Factor(dB)
3. The other emission levels were very low against the limit.
4. Margin value = Emission Level – Limit value

## 4.2 Transmit Power Measurement

### 4.2.1 Limits of Transmit Power Measurement

Operation Band	EUT Category		LIMIT
U-NII-1		Outdoor Access Point	1 Watt (30 dBm) (Max. e.i.r.p $\leq$ 125mW(21 dBm) at any elevation angle above 30 degrees as measured from the horizon)
		Fixed point-to-point Access Point	1 Watt (30 dBm)
		Indoor Access Point	1 Watt (30 dBm)
		Mobile and Portable client device	250mW (24 dBm)
U-NII-2A			250mW (24 dBm) or 11 dBm+10 log B*
U-NII-2C			250mW (24 dBm) or 11 dBm+10 log B*
U-NII-3	√		1 Watt (30 dBm)

\*B is the 26 dB emission bandwidth in megahertz

Per KDB 662911 Method of conducted output power measurement on IEEE 802.11 devices,

Array Gain = 0 dB (i.e., no array gain) for  $N_{ANT} \leq 4$ ;

Array Gain = 0 dB (i.e., no array gain) for channel widths  $\geq 40$  MHz for any  $N_{ANT}$ ;

Array Gain =  $5 \log(N_{ANT}/N_{SS})$  dB or 3 dB, whichever is less for 20-MHz channel widths with  $N_{ANT} \geq 5$ .

For power measurements on all other devices: Array Gain =  $10 \log(N_{ANT}/N_{SS})$  dB.

### 4.2.2 Test Setup

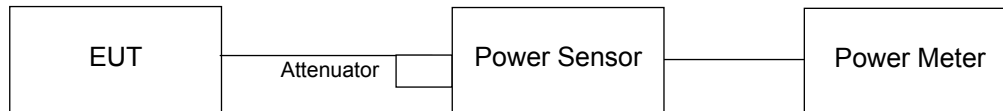

### 4.2.3 Test Instruments

Refer to section 4.1.2 to get information of above instrument.

### 4.2.4 Test Procedure

Method PM is used to perform output power measurement, trigger and gating function of wide band power meter is enabled to measure max output power of TX on burst. Duty factor is not added to measured value.

### 4.2.5 Deviation from Test Standard

No deviation.

### 4.2.6 EUT Operating Condition

The software provided by client to enable the EUT under transmission condition continuously at lowest, middle and highest channel frequencies individually.

#### 4.2.7 Test Result

### POWER OUTPUT

#### 802.11a

Chan.	Chan. Freq. (MHz)	Maximum Conducted Power (dBm)		Total Power (mW)	Total Power (dBm)	Limit (dBm)	Pass / Fail
		Chain 0	Chain 1				
149	5745	18.25	18.01	130.075	21.14	30	Pass
157	5785	18.11	18.23	131.241	21.18	30	Pass
165	5825	18.06	18.13	128.986	21.11	30	Pass

#### 802.11ac (VHT20)

Chan.	Chan. Freq. (MHz)	Maximum Conducted Power (dBm)		Total Power (mW)	Total Power (dBm)	Limit (dBm)	Pass / Fail
		Chain 0	Chain 1				
149	5745	16.06	15.06	72.428	18.60	27.99	Pass
157	5785	18.22	18.03	129.907	21.14	27.99	Pass
165	5825	18.13	18.30	132.621	21.23	27.99	Pass

Note: 1. Directional gain = 5dBi + 10log(2) = 8.01dBi > 6dBi , so the power limit shall be reduced to 30-(8.01-6) = 27.99dBm.

#### 802.11ac (VHT40)

Chan.	Chan. Freq. (MHz)	Maximum Conducted Power (dBm)		Total Power (mW)	Total Power (dBm)	Limit (dBm)	Pass / Fail
		Chain 0	Chain 1				
151	5755	12.59	12.01	34.04	15.32	27.99	Pass
159	5795	18.13	18.19	130.93	21.17	27.99	Pass

Note: 1. Directional gain = 5dBi + 10log(2) = 8.01dBi > 6dBi , so the power limit shall be reduced to 30-(8.01-6) = 27.99dBm.

#### 802.11ac (VHT80)

Chan.	Chan. Freq. (MHz)	Maximum Conducted Power (dBm)		Total Power (mW)	Total Power (dBm)	Limit (dBm)	Pass / Fail
		Chain 0	Chain 1				
155	5775	10.61	9.78	21.014	13.23	27.99	Pass

Note: 1. Directional gain = 5dBi + 10log(2) = 8.01dBi > 6dBi , so the power limit shall be reduced to 30-(8.01-6) = 27.99dBm.

### 4.3 Peak Power Spectral Density Measurement

#### 4.3.1 Limits of Peak Power Spectral Density Measurement

Operation Band	EUT Category		LIMIT
U-NII-1		Outdoor Access Point	17dBm/ MHz
		Fixed point-to-point Access Point	
		Indoor Access Point	
		Mobile and Portable client device	11dBm/ MHz
U-NII-2A			11dBm/ MHz
U-NII-2C			11dBm/ MHz
U-NII-3		√	30dBm/ 500kHz

#### 4.3.2 Test Setup

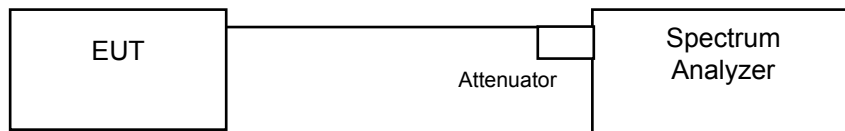

#### 4.3.3 Test Instruments

Refer to section 4.1.2 to get information of above instrument.

#### 4.3.4 Test Procedure

1. Set span to encompass the entire emission bandwidth (EBW) of the signal.
2. Set RBW = 300 kHz, Set VBW ≥ 1 MHz, Detector = RMS
3. Use the peak marker function to determine the maximum power level in any 300 kHz band segment within the fundamental EBW.
4. Scale the observed power level to an equivalent value in 500 kHz by adjusting (reducing) the measured power by a bandwidth correction factor (BWCF) where  $BWCF = 10\log(500\text{kHz}/300\text{kHz})$
5. Sweep time = auto, trigger set to “free run”.
6. Trace average at least 100 traces in power averaging mode.
7. Record the max value

#### 4.3.5 Deviation from Test Standard

No deviation.

#### 4.3.6 EUT Operating Condition

Same as Item 4.2.6.

### 4.3.7 Test Results

#### 802.11a

TX chain	Channel	Freq. (MHz)	PSD (dBm/300kHz)	PSD (dBm/500kHz)	10 log (N=2) dB	Total PSD (dBm/500kHz)	Limit (dBm/500kHz)	Pass /Fail
0	149	5745	-3.14	-0.92	3.01	2.09	27.99	Pass
	157	5785	-3.93	-1.71	3.01	1.30	27.99	Pass
	165	5825	-4.23	-2.01	3.01	1.00	27.99	Pass
1	149	5745	-3.78	-1.56	3.01	1.45	27.99	Pass
	157	5785	-3.04	-0.82	3.01	2.19	27.99	Pass
	165	5825	-2.89	-0.67	3.01	2.34	27.99	Pass

Note: 1. Directional gain =  $5\text{dBi} + 10\log(2) = 8.01\text{dBi} > 6\text{dBi}$  , so the power density limit shall be reduced to  $30-(8.01-6) = 27.99\text{dBm}$ .

#### 802.11ac (VHT20)

TX chain	Channel	Freq. (MHz)	PSD (dBm/300kHz)	PSD (dBm/500kHz)	10 log (N=2) dB	Total PSD (dBm/500kHz)	Limit (dBm/500kHz)	Pass /Fail
0	149	5745	-6.28	-4.06	3.01	-1.05	27.99	Pass
	157	5785	-4.43	-2.21	3.01	0.80	27.99	Pass
	165	5825	-4.59	-2.37	3.01	0.64	27.99	Pass
1	149	5745	-6.89	-4.67	3.01	-1.66	27.99	Pass
	157	5785	-3.99	-1.77	3.01	1.24	27.99	Pass
	165	5825	-3.63	-1.41	3.01	1.60	27.99	Pass

Note: 1. Directional gain =  $5\text{dBi} + 10\log(2) = 8.01\text{dBi} > 6\text{dBi}$  , so the power density limit shall be reduced to  $30-(8.01-6) = 27.99\text{dBm}$ .

#### 802.11ac (VHT40)

TX chain	Channel	Freq. (MHz)	PSD (dBm/300kHz)	PSD (dBm/500kHz)	10 log (N=2) dB	Total PSD (dBm/500kHz)	Limit (dBm/500kHz)	Pass /Fail
0	151	5755	-13.21	-10.99	3.01	-7.98	27.99	Pass
	159	5795	-8.45	-6.23	3.01	-3.22	27.99	Pass
1	151	5755	-13.78	-11.56	3.01	-8.55	27.99	Pass
	159	5795	-7.22	-5.00	3.01	-1.99	27.99	Pass

Note: 1. Directional gain =  $5\text{dBi} + 10\log(2) = 8.01\text{dBi} > 6\text{dBi}$  , so the power density limit shall be reduced to  $30-(8.01-6) = 27.99\text{dBm}$ .

### 802.11ac (VHT80)

TX chain	Channel	Freq. (MHz)	PSD (dBm/300kHz)	PSD (dBm/500kHz)	10 log (N=2) dB	Total PSD (dBm/500kHz)	Limit (dBm/500kHz)	Pass /Fail
0	155	5775	-17.36	-15.14	3.01	-12.13	27.99	Pass
1	155	5775	-17.51	-15.29	3.01	-12.28	27.99	Pass

Note: 1. Directional gain = 5dBi + 10log(2) = 8.01dBi > 6dBi , so the power density limit shall be reduced to 30-(8.01-6) = 27.99dBm.

### Spectrum Plot of Worst Value

**802.11a – Chain 1: CH 165**

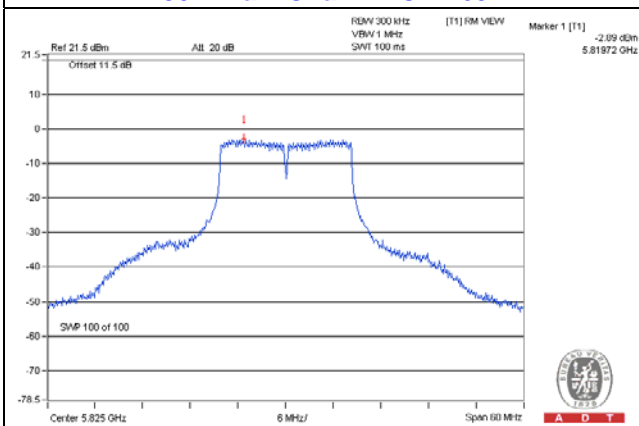

**802.11ac (VHT20) – Chain 1: CH 165**

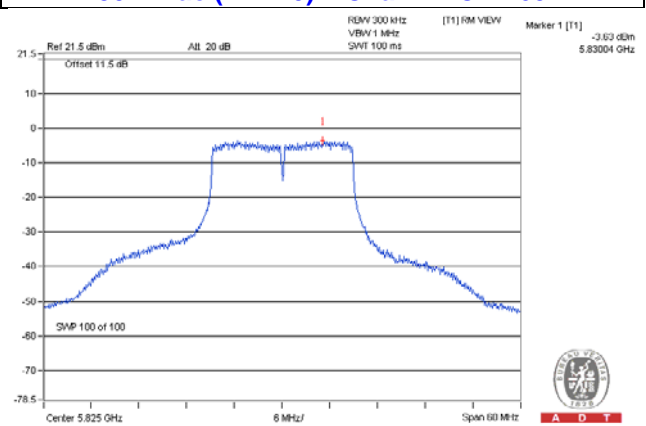

**802.11ac (VHT40) – Chain 1: CH 159**

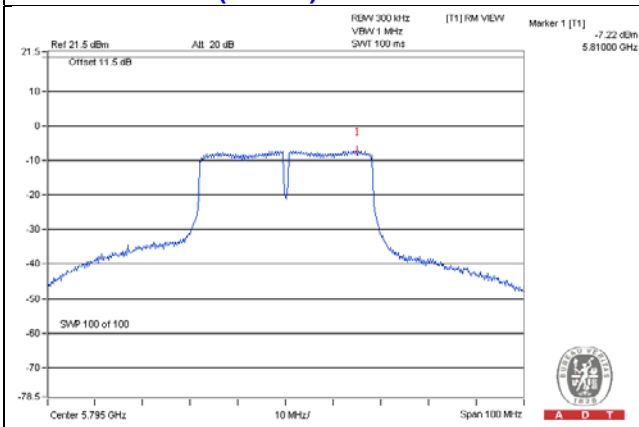

**802.11ac (VHT80) – Chain 0: CH 155**

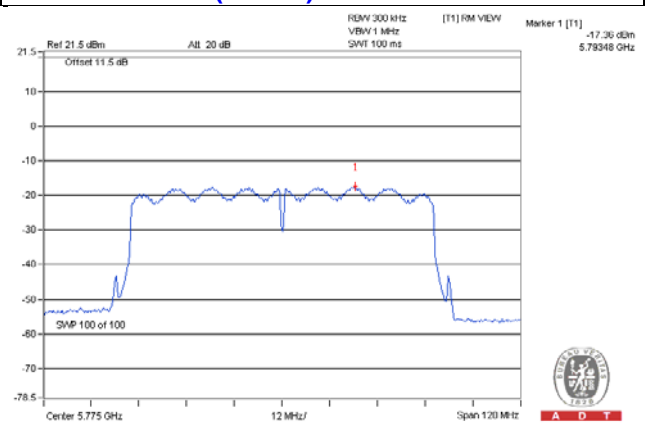

## 4.4 Frequency Stability Measurement

### 4.4.1 Limits of Frequency Stability Measurement

The frequency of the carrier signal shall be maintained within band of operation

### 4.4.2 Test Setup

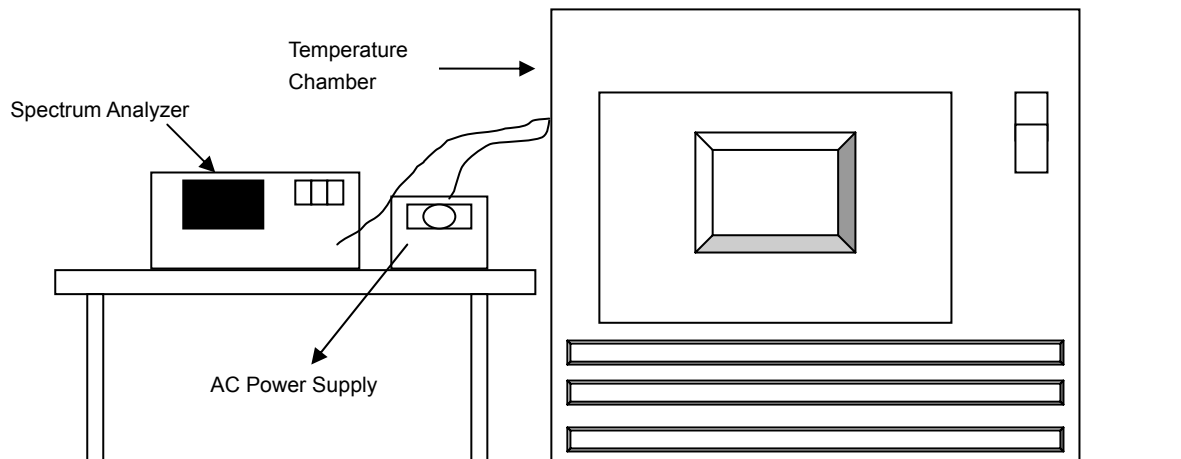

### 4.4.3 Test Instruments

Refer to section 4.1.2 to get information of above instrument.

### 4.4.4 Test Procedure

- The EUT was placed inside the environmental test chamber and powered by nominal AC voltage.
- Turn the EUT on and couple its output to a spectrum analyzer.
- Turn the EUT off and set the chamber to the highest temperature specified.
- Allow sufficient time (approximately 30 min) for the temperature of the chamber to stabilize, turn the EUT on and measure the operating frequency after 2, 5, and 10 minutes.
- Repeat step 2 and 3 with the temperature chamber set to the lowest temperature.
- The test chamber was allowed to stabilize at +20 degree C for a minimum of 30 minutes. The supply voltage was then adjusted on the EUT from 85% to 115% and the frequency record.

### 4.4.5 Deviation from Test Standard

No deviation.

### 4.4.6 EUT Operating Condition

Set the EUT transmit at un-modulation mode to test frequency stability.

**4.4.7 Test Results**

<b>FREQUENCY STABILITY VERSUS TEMP.</b>									
<b>OPERATING FREQUENCY: 5745MHz</b>									
<b>TEMP. (°C)</b>	<b>POWER SUPPLY (Vac)</b>	<b>0 MINUTE</b>		<b>2 MINUTE</b>		<b>5 MINUTE</b>		<b>10 MINUTE</b>	
		<b>Measured Frequency (MHz)</b>	<b>Frequency Drift (%)</b>	<b>Measured Frequency (MHz)</b>	<b>Frequency Drift (%)</b>	<b>Measured Frequency (MHz)</b>	<b>Frequency Drift (%)</b>	<b>Measured Frequency (MHz)</b>	<b>Frequency Drift (%)</b>
50	120	5744.985	-0.00026	5744.9853	-0.00026	5744.9841	-0.00028	5744.9807	-0.00034
40	120	5745.0047	0.00008	5745.0021	0.00004	5745.0037	0.00006	5745.0056	0.00010
30	120	5744.9969	-0.00005	5744.9943	-0.00010	5744.9929	-0.00012	5744.997	-0.00005
20	120	5744.9876	-0.00022	5744.9865	-0.00023	5744.9844	-0.00027	5744.9862	-0.00024
10	120	5744.9993	-0.00001	5744.9988	-0.00002	5745.0033	0.00006	5745.002	0.00003
0	120	5745.0195	0.00034	5745.021	0.00037	5745.0182	0.00032	5745.0209	0.00036
-10	120	5745.0024	0.00004	5744.9977	-0.00004	5744.9993	-0.00001	5744.9987	-0.00002
-20	120	5745.015	0.00026	5745.0179	0.00031	5745.0193	0.00034	5745.0163	0.00028
-30	120	5744.9782	-0.00038	5744.9751	-0.00043	5744.976	-0.00042	5744.9744	-0.00045

<b>FREQUENCY STABILITY VERSUS VOLTAGE</b>									
<b>OPERATING FREQUENCY: 5745MHz</b>									
<b>TEMP. (°C)</b>	<b>POWER SUPPLY (Vac)</b>	<b>0 MINUTE</b>		<b>2 MINUTE</b>		<b>5 MINUTE</b>		<b>10 MINUTE</b>	
		<b>Measured Frequency (MHz)</b>	<b>Frequency Drift (%)</b>	<b>Measured Frequency (MHz)</b>	<b>Frequency Drift (%)</b>	<b>Measured Frequency (MHz)</b>	<b>Frequency Drift (%)</b>	<b>Measured Frequency (MHz)</b>	<b>Frequency Drift (%)</b>
20	138	5744.9873	-0.00022	5744.9865	-0.00023	5744.9838	-0.00028	5744.9858	-0.00025
	120	5744.9876	-0.00022	5744.9865	-0.00023	5744.9844	-0.00027	5744.9862	-0.00024
	102	5744.987	-0.00023	5744.9873	-0.00022	5744.9837	-0.00028	5744.9867	-0.00023



## 4.5 6dB Bandwidth Measurement

### 4.5.1 Limits of 6dB Bandwidth Measurement

The minimum of 6dB Bandwidth Measurement is 0.5MHz.

### 4.5.2 Test Setup

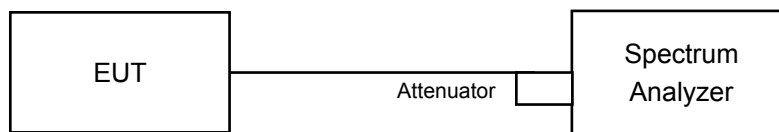

### 4.5.3 Test Instruments

Refer to section 4.1.2 to get information of above instrument.

### 4.5.4 Test Procedure

#### MEASUREMENT PROCEDURE REF

- Set resolution bandwidth (RBW) = 100kHz
- Set the video bandwidth (VBW)  $\geq 3 \times$  RBW, Detector = Peak.
- Trace mode = max hold.
- Sweep = auto couple.
- Measure the maximum width of the emission that is constrained by the frequencies associated with the two amplitude points (upper and lower) that are attenuated by 6 dB relative to the maximum level measured in the fundamental emission

### 4.5.5 Deviation from Test Standard

No deviation.

### 4.5.6 EUT Operating Condition

The software provided by client to enable the EUT under transmission condition continuously at lowest, middle and highest channel frequencies individually.

#### 4.5.7 Test Results

##### 802.11a

Channel	Frequency (MHz)	6dB Bandwidth (MHz)		Minimum Limit (MHz)	Pass / Fail
		Chain 0	Chain 1		
149	5745	16.62	16.49	0.5	Pass
157	5785	16.62	16.59	0.5	Pass
165	5825	16.62	16.57	0.5	Pass

##### 802.11ac (VHT20)

Channel	Frequency (MHz)	6dB Bandwidth (MHz)		Minimum Limit (MHz)	Pass / Fail
		Chain 0	Chain 1		
149	5745	17.79	17.80	0.5	Pass
157	5785	17.81	17.79	0.5	Pass
165	5825	17.80	17.74	0.5	Pass

##### 802.11ac (VHT40)

Channel	Frequency (MHz)	6dB Bandwidth (MHz)		Minimum Limit (MHz)	Pass / Fail
		Chain 0	Chain 1		
151	5755	36.62	36.62	0.5	Pass
159	5795	36.61	36.62	0.5	Pass

##### 802.11ac (VHT80)

Channel	Frequency (MHz)	6dB Bandwidth (MHz)		Minimum Limit (MHz)	Pass / Fail
		Chain 0	Chain 1		
155	5775	76.16	76.15	0.5	Pass

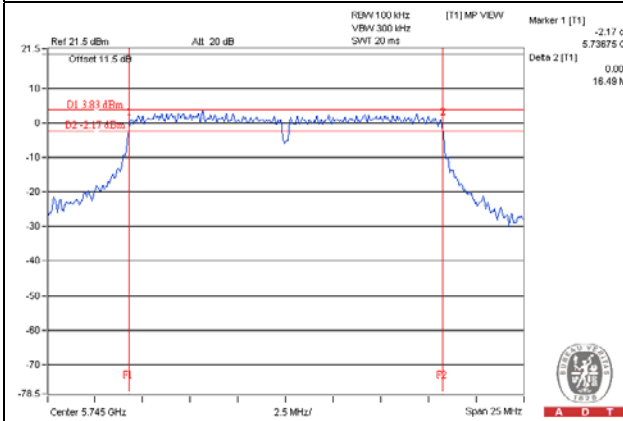
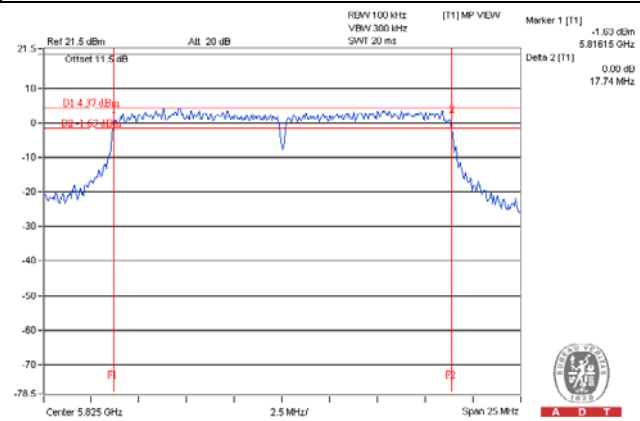
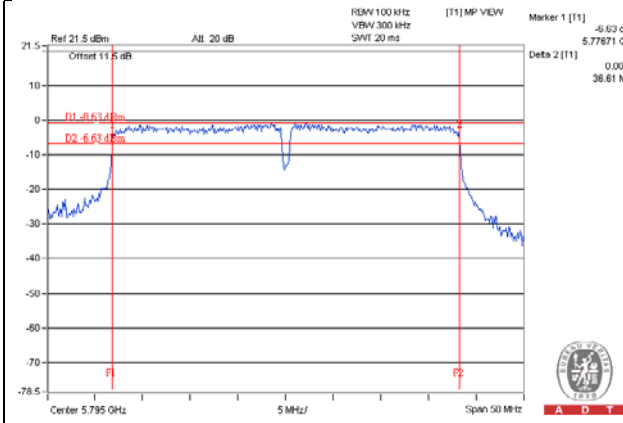
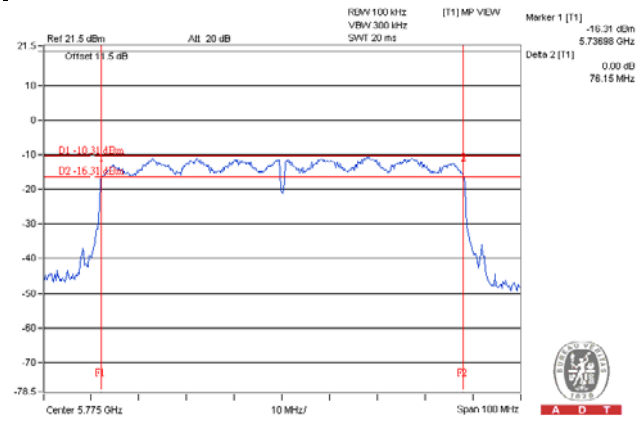
**Spectrum Plot of Worst Value****802.11a – Chain 1: CH 149****802.11ac (VHT20) – Chain 1: CH 165****802.11ac (VHT40) – Chain 0: CH 159****802.11ac (VHT80) – Chain 1: CH 155**

## 5 Pictures of Test Arrangements

Please refer to the attached file (Test Setup Photo).

## Appendix – Information on the Testing Laboratories

We, Bureau Veritas Consumer Products Services (H.K.) Ltd., Taoyuan Branch, were founded in 1988 to provide our best service in EMC, Radio, Telecom and Safety consultation. Our laboratories are accredited and approved according to ISO/IEC 17025.

If you have any comments, please feel free to contact us at the following:

**Linko EMC/RF Lab**

Tel: 886-2-26052180

Fax: 886-2-26051924

**Hsin Chu EMC/RF Lab/Telecom Lab**

Tel: 886-3-6668565

Fax: 886-3-6668323

**Hwa Ya EMC/RF/Safety**

Tel: 886-3-3183232

Fax: 886-3-3270892

**Email:** [service.adt@tw.bureauveritas.com](mailto:service.adt@tw.bureauveritas.com)

**Web Site:** [www.bureauveritas-adt.com](http://www.bureauveritas-adt.com)

The address and road map of all our labs can be found in our web site also.

--- END ---