



SPORTON International Inc.

No.8, Lane 724, Bo-ai St., Jhubei City, HsinChu County 302, Taiwan, R.O.C.
Ph: 886-3-656-9065 / FAX: 886-3-656-9085 / www.sporton.com.tw

FCC RADIO TEST REPORT

Applicant's company	Realtek Semiconductor Corp.
Applicant Address	No. 2, Innovation Road II, Hsinchu Science Park, Hsinchu 300, Taiwan
FCC ID	TX2RTL8192DEB8
Manufacturer's company	Realtek Semiconductor Corp.
Manufacturer Address	No. 2, Innovation Road II, Hsinchu Science Park, Hsinchu 300, Taiwan

Product Name	802.11a/b/g/n RTL8192DE Combo miniCard
Brand Name	Realtek
Model Name	RTL8192DEB8
Test Rule	47 CFR FCC Part 15 Subpart C § 15.247
Test Freq. Range	2400 ~ 2483.5MHz
Received Date	Nov. 15, 2011
Final Test Date	Dec. 27, 2011
Submission Type	Original Equipment

Statement

Test result included is only for the Bluetooth part of the product.

The test result in this report refers exclusively to the presented test model / sample.

Without written approval of SPORTON International Inc., the test report shall not be reproduced except in full.

The measurements and test results shown in this test report were made in accordance with the procedures and found in compliance with the limit given in **ANSI C63.10-2009** and **47 CFR FCC Part 15 Subpart C**.

The test equipment used to perform the test is calibrated and traceable to NML/ROC.



Table of Contents

1. CERTIFICATE OF COMPLIANCE	1
2. SUMMARY OF THE TEST RESULT	2
3. GENERAL INFORMATION	3
3.1. Product Details.....	3
3.2. Accessories.....	3
3.3. Table for Filed Antenna.....	3
3.4. Table for Carrier Frequencies	6
3.5. Table for Test Modes.....	6
3.6. Table for Testing Locations.....	7
3.7. Table for Supporting Units	7
3.8. Table for Parameters of Test Software Setting	8
3.9. Test Configurations	9
4. TEST RESULT	15
4.1. AC Power Line Conducted Emissions Measurement.....	15
4.2. Maximum Peak Output Power Measurement	21
4.3. Average Output Power Measurement	23
4.4. Hopping Channel Separation Measurement	25
4.5. Number of Hopping Frequency Measurement.....	31
4.6. Dwell Time Measurement.....	38
4.7. Radiated Emissions Measurement	47
4.8. Band Edge Emissions Measurement	67
4.9. Antenna Requirements	76
5. LIST OF MEASURING EQUIPMENTS	77
6. TEST LOCATION.....	79
7. TAF CERTIFICATE OF ACCREDITATION	80
APPENDIX A. TEST PHOTOS	A1 ~ A12
APPENDIX B. MAXIMUM PERMISSIBLE EXPOSURE	B1 ~ B3
APPENDIX C. CO-LOCATION REPORT.....	C1 ~ C5
APPENDIX D. ANTENNA LIST	D1 ~ D14



History of This Test Report

REPORT NO.	VERSION	DESCRIPTION	ISSUED DATE
FR1N1521AB	Rev. 01	Initial issue of report	Jan. 02, 2012



1. CERTIFICATE OF COMPLIANCE

Product Name : 802.11a/b/g/n RTL8192DE Combo miniCard
Brand Name : Realtek
Model Name : RTL8192DEB8
Applicant : Realtek Semiconductor Corp.
Test Rule Part(s) : 47 CFR FCC Part 15 Subpart C § 15.247

Sporton International as requested by the applicant to evaluate the EMC performance of the product sample received on Nov. 15, 2011 would like to declare that the tested sample has been evaluated and found to be in compliance with the tested rule parts. The data recorded as well as the test configuration specified is true and accurate for showing the sample's EMC nature.

A handwritten signature in blue ink that reads 'Jordan Hsiao' is written over a horizontal line.

Jordan Hsiao

SPORTON INTERNATIONAL INC.

2. SUMMARY OF THE TEST RESULT

Applied Standard: 47 CFR FCC Part 15 Subpart C				
Part	Rule Section	Description of Test	Result	Under Limit
4.1	15.207	AC Power Line Conducted Emissions	Complies	12.62 dB
4.2	15.247(b)(1)	Maximum Peak Conducted Output Power	Complies	11.12 dB
4.3	-	Average Output Power	-	-
4.4	15.247(a)(1)	Hopping Channel Separation	Complies	-
4.5	15.247(b)(1)	Number of Hopping Frequency	Complies	-
4.6	15.247(a)(1)	Dwell Time	Complies	-
4.7	15.247(d)	Radiated Emissions	Complies	1.31 dB
4.8	15.247(d)	Band Edge Emissions	Complies	2.52 dB
4.9	15.203	Antenna Requirements	Complies	-

Test Items	Uncertainty	Remark
AC Power Line Conducted Emissions	±2.3dB	Confidence levels of 95%
Maximum Peak Conducted Output Power	±0.8dB	Confidence levels of 95%
Hopping Channel Separation	±8.5×10 ⁻⁸	Confidence levels of 95%
Radiated Emissions (9kHz~30MHz)	±0.8dB	Confidence levels of 95%
Radiated Emissions (30MHz~1000MHz)	±1.9dB	Confidence levels of 95%
Radiated / Band Edge Emissions (1GHz~18GHz)	±1.9dB	Confidence levels of 95%
Radiated Emissions (18GHz~40GHz)	±1.9dB	Confidence levels of 95%
Temperature	±0.7°C	Confidence levels of 95%
Humidity	±3.2%	Confidence levels of 95%
DC / AC Power Source	±1.4%	Confidence levels of 95%

3. GENERAL INFORMATION

3.1. Product Details

Items	Description
Power Type	From Host System
Modulation	FHSS (GFSK / $\pi/4$ -DQPSK / 8DPSK)
Data Rate (Mbps)	GFSK: 1 ; $\pi/4$ -QPSK: 2 ; 8DPSK: 3
Frequency Range	2400 ~ 2483.5MHz
Channel Number	For Bluetooth 2.1 + EDR: 79 For Bluetooth 4.0: 40 (37 hopping + 3 advertising channel)
Channel Band Width (99%)	For Bluetooth 2.1 + EDR : 1.1920 MHz For Bluetooth 4.0 : 1.0246 MHz
Peak Conducted Output Power	For Bluetooth 2.1 + EDR : 8.52 dBm For Bluetooth 4.0 : 9.88 dBm
Carrier Frequencies	Please refer to section 3.4
Antenna	Please refer to section 3.3
Remark: The different between Bluetooth 2.1 + EDR and Bluetooth 4.0 is software version.	

3.2. Accessories

N/A

3.3. Table for Filed Antenna

Ant.	Brand	Model Name	Antenna Type	Connector	Gain (dBi)		Chain
					2.4GHz	5GHz	
1	JOYMAX	TWF-614XMPXX-500	Dipole Antenna	Reversed-SMA	3	5	Chain1/Chain2
2	LYNwave	ALA110-222050	PIFA Antenna	I-PEX	3.5	5	Chain1/Chain2

Note: The EUT has two different type antennas.

The detail information of antennas, please refer to Appendix D.

<2.4GHz WALN function without Bluetooth function:>

For IEEE 802.11b mode (1TX,1RX)

The EUT supports the antenna with TX/RX diversity function.

Both Chain 1 and Chain 2 can be used as transmitting/receiving antennas, but only one of them is used as transmitting/receiving antenna at the same time.

Due to Chain 1 generated higher output power, so all tests were base on this setting and recorded in this report.

For IEEE 802.11g mode (1TX, 2RX)

Both Chain 1 and Chain 2 can be used as receiving antennas, and they can receive signal simultaneously.

The EUT supports the antenna with TX diversity function.

Both Chain 1 and Chain 2 can be used as transmitting antenna, but only one of them is used as transmitting antenna at the same time.

Due to Chain 1 generated higher output power, so all tests were base on this setting and recorded in this report.

For IEEE 802.11a mode (1TX, 2RX)

Both Chain 1 and Chain 2 can be used as receiving antennas, and they can receive signal simultaneously.

The EUT supports the antenna with TX diversity function.

Both Chain 1 and Chain 2 can be used as transmitting antenna, but only one of them is used as transmitting antenna at the same time.

Due to Chain 1 generated higher output power, so all tests were base on this setting and recorded in this report.

For IEEE 802.11n mode (1TX, 2RX)

Both Chain 1 and Chain 2 can be used as receiving antennas, and they can receive signal simultaneously.

The EUT supports the antenna with TX diversity function.

Both Chain 1 and Chain 2 can be used as transmitting antenna, but only one of them is used as transmitting antenna at the same time.

Due to Chain 1 generated higher output power, so all tests were base on this setting and recorded in this report.

For IEEE 802.11n Mode: (2TX, 2RX)

Both Chain 1 and Chain 2 can be used as transmitting/receiving antennas, and they can transmit/receive signal simultaneously.

Note: For 802.11n mode, only 2TX function was selected to test and record in the report and the single power of peak output power for 1TX function will follow this same test result.

<2.4GHz WALN function with Bluetooth function:>

For IEEE 802.11b/g/n Mode: (1TX, 1RX)

Only Chain 1 can be used as transmitting/receiving antenna.

For Bluetooth Mode:

Only Chain 2 can be used as transmitting/receiving antenna.

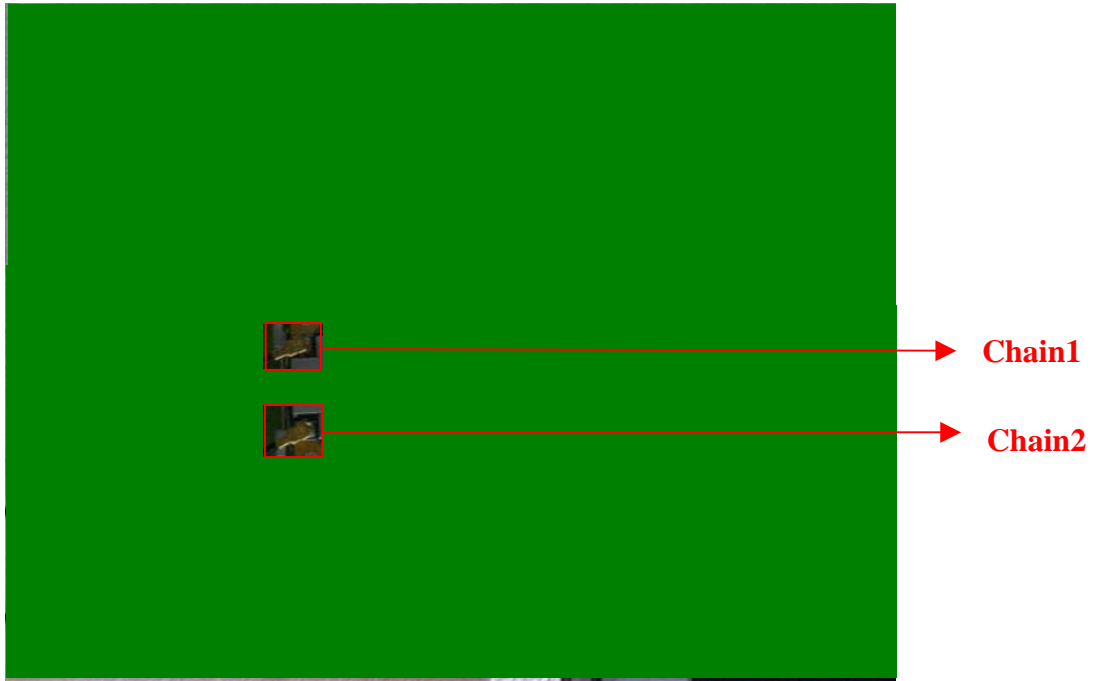

3.4. Table for Carrier Frequencies

For Bluetooth 2.1 + EDR :

Frequency Band	Channel No.	Frequency	Channel No.	Frequency
2400~2483.5MHz	0	2402 MHz	40	2442 MHz
	1	2403 MHz	:	:
	:	:	77	2479 MHz
	38	2440 MHz	78	2480 MHz
	39	2441 MHz	-	-

For Bluetooth 4.0 :

Frequency Band	Channel No.	Frequency	Channel No.	Frequency
2400~2483.5MHz	0	2402 MHz	20	2442 MHz
	1	2404 MHz	:	:
	2	2406 MHz	37	2476 MHz
	:	:	38	2478 MHz
	18	2438 MHz	39	2480 MHz
	19	2440 MHz	-	-

3.5. Table for Test Modes

Preliminary tests were performed in different data rate to find the worst radiated emission. The data rate shown in the table below is the worst-case rate with respect to the specific test item. Investigation has been done on all the possible configurations for searching the worst cases. The following table is a list of the test modes shown in this test report.

For Bluetooth 2.1 + EDR :

Test Items	Mode	Data Rate	Channel	Chain
AC Power Conducted Emissions	Normal Link	3 Mbps	Hopping 0~78	-
Max. Conducted Output Power	8DPSK	3 Mbps	0/39/78	2
Hopping Channel Separation	8DPSK	3 Mbps	0~1/39~40/77~78	2
Number of Hopping Frequency	8DPSK	3 Mbps	0~78	2
Dwell Time	3DH1/3DH3/3DH5	3 Mbps	0/39/78	2
Radiated Emissions Below 1GHz	8DPSK	3 Mbps	39	2
Radiated Emissions Above 1GHz	8DPSK	3 Mbps	0/39/78	2
Band Edge Emissions	8DPSK	3 Mbps	0/78	2

For Bluetooth 4.0 :

Test Items	Mode	Data Rate	Channel	Chain
AC Power Conducted Emissions	Normal Link	1 Mbps	Hopping 0~39	-
Max. Peak Conducted Output Power	GFSK	1 Mbps	0/19/39	2
Average Output Power	GFSK	1 Mbps	0/19/39	2
Hopping Channel Separation	GFSK	1 Mbps	0~1/19~20/38~39	2
Number of Hopping Frequency	GFSK	1 Mbps	0~39	2
Dwell Time	DH1	1 Mbps	0/19/39	2
Radiated Emissions Below 1GHz	GFSK	1 Mbps	19	2
Radiated Emissions Above 1GHz	GFSK	1 Mbps	0/19/39	2
Band Edge Emissions	GFSK	1 Mbps	0/39	2

The following test modes were performed for all tests:

Mode 1. WLAN + Bluetooth With Dipole antenna.

Mode 2. WLAN + Bluetooth With PIFA antenna.

3.6. Table for Testing Locations

Test Site No.	Site Category	Location	FCC Reg. No.	IC File No.	VCCI Reg. No
03CH01-CB	SAC	Hsin Chu	262045	IC 4086D	-
CO01-CB	Conduction	Hsin Chu	262045	IC 4086D	-
TH01-CB	OVEN Room	Hsin Chu	-	-	-

Open Area Test Site (OATS); Semi Anechoic Chamber (SAC); Fully Anechoic Chamber (FAC).

Please refer section 6 for Test Site Address.

3.7. Table for Supporting Units

Support Unit	Brand	Model	FCC ID
Notebook	DELL	1340	E2K4965AGNM
Wireless AP	BELKIN	WG7016G22-LF-AK	N/A
Mouse	Logitech	M-U0026	DoC
Modem	ACEEX	DM1414	IFAXDM1414
Bluetooth V2.1	SEEHOT	SBD10	N/A

3.8. Table for Parameters of Test Software Setting

During testing, Channel & Power Controlling Software provided by the customer was used to control the operating channel as well as the output power level. The RF output power selection is for the setting of RF output power expected by the customer and is going to be fixed on the firmware of the final end product.

For Bluetooth 2.1 + EDR :

Power Parameters of Bluetooth

Test Software Version	Blue Core Blue tooth 2.3.0.15		
Frequency	2402 MHz	2441 MHz	2480 MHz
Power Parameters	105	105	105

During the test, "Blue Core Blue tooth 2.3.0.15" under WIN XP was executed the test program to control the EUT continuously transmit RF signal.

For Bluetooth 4.0 :

Power Parameters of Bluetooth

Test Software Version	CSR BLUESUITE 2.4.6		
Frequency	2402 MHz	2440 MHz	2480 MHz
Power Parameters	105	105	105

During the test, "CSR BLUESUITE 2.4.6" under WIN XP was executed the test program to control the EUT continuously transmit RF signal.

3.9. Test Configurations

3.9.1. Radiation Emissions Test Configuration

Test Configuration: 30MHz~1GHz / Mode 1

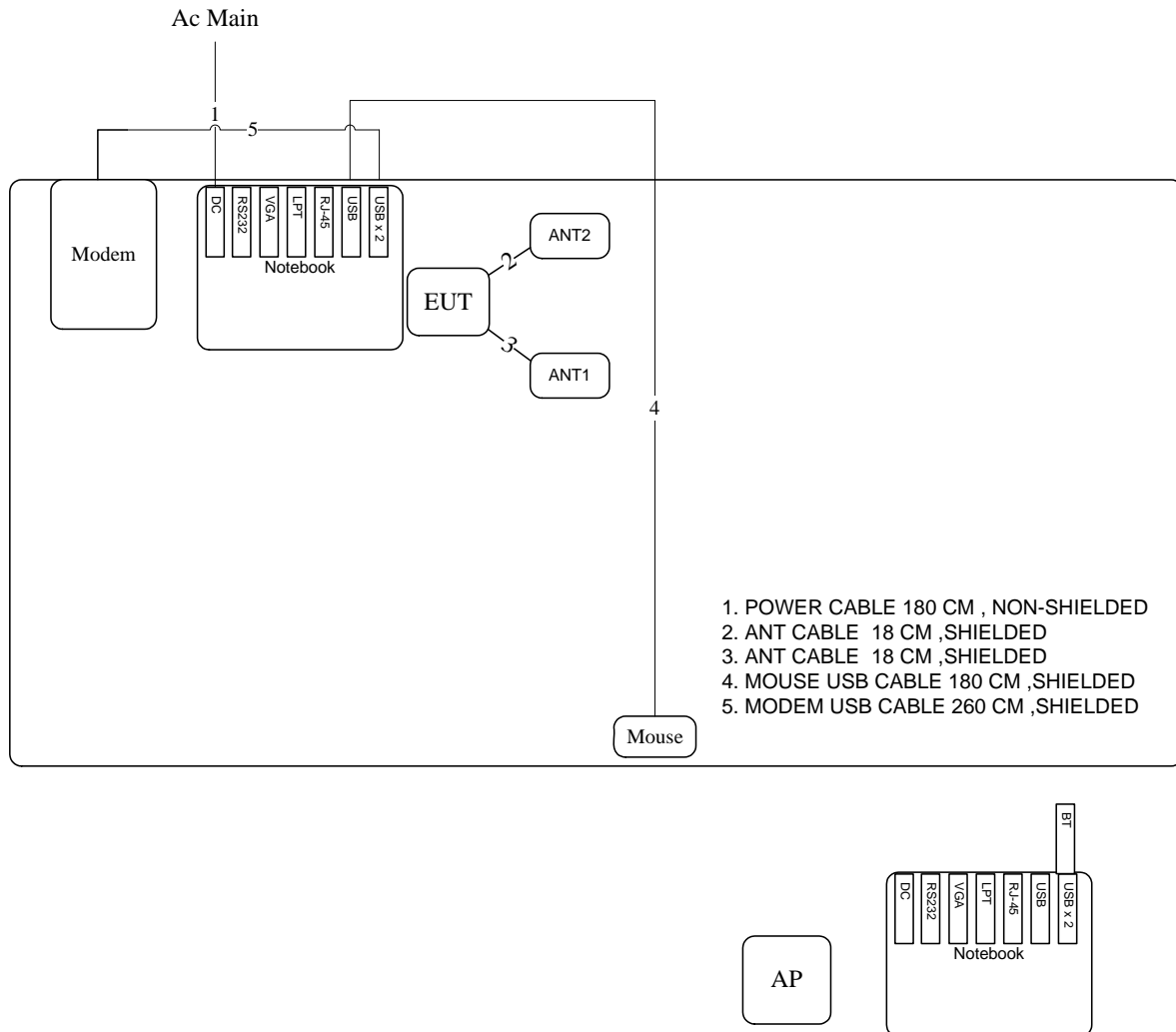

Test Configuration: 30MHz~1GHz / Mode 2

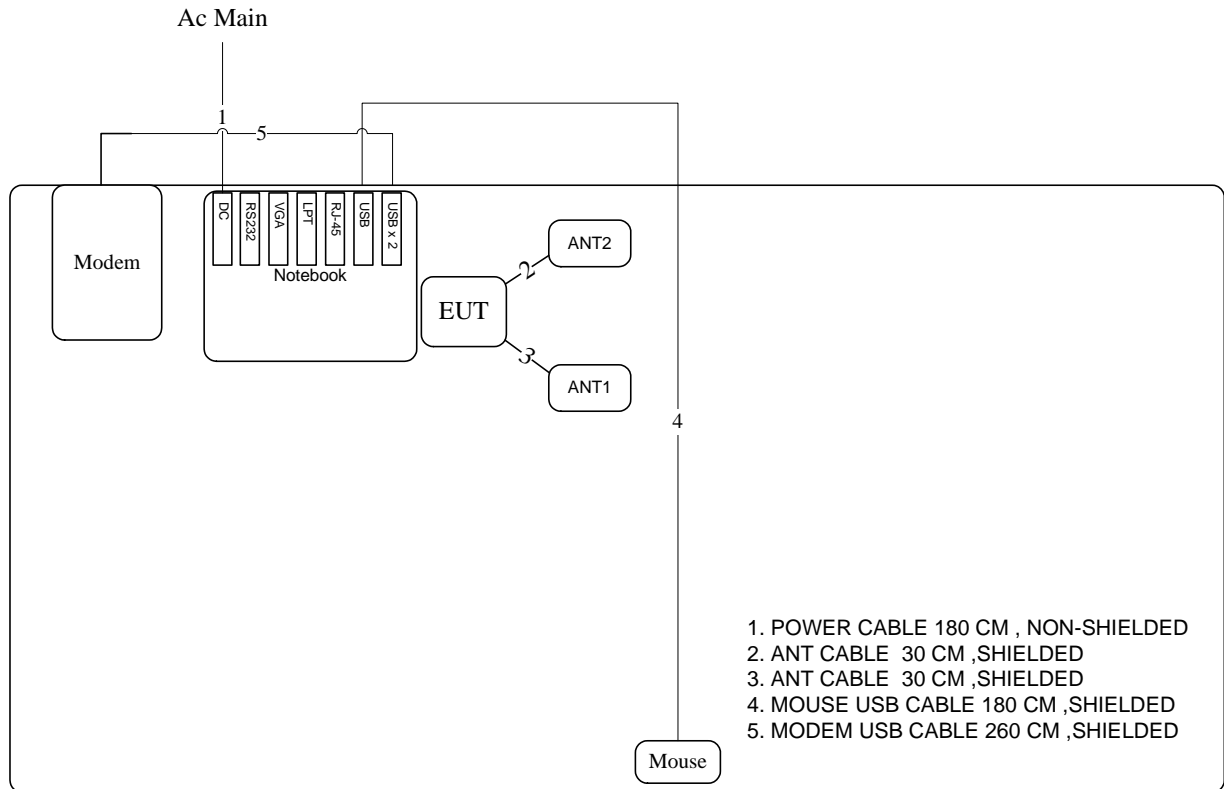

1. POWER CABLE 180 CM , NON-SHIELDED
2. ANT CABLE 30 CM ,SHIELDED
3. ANT CABLE 30 CM ,SHIELDED
4. MOUSE USB CABLE 180 CM , SHIELDED
5. MODEM USB CABLE 260 CM ,SHIELDED

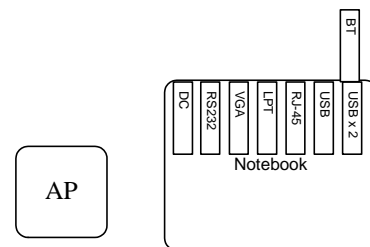

Test Configuration: above 1GHz / Mode 1

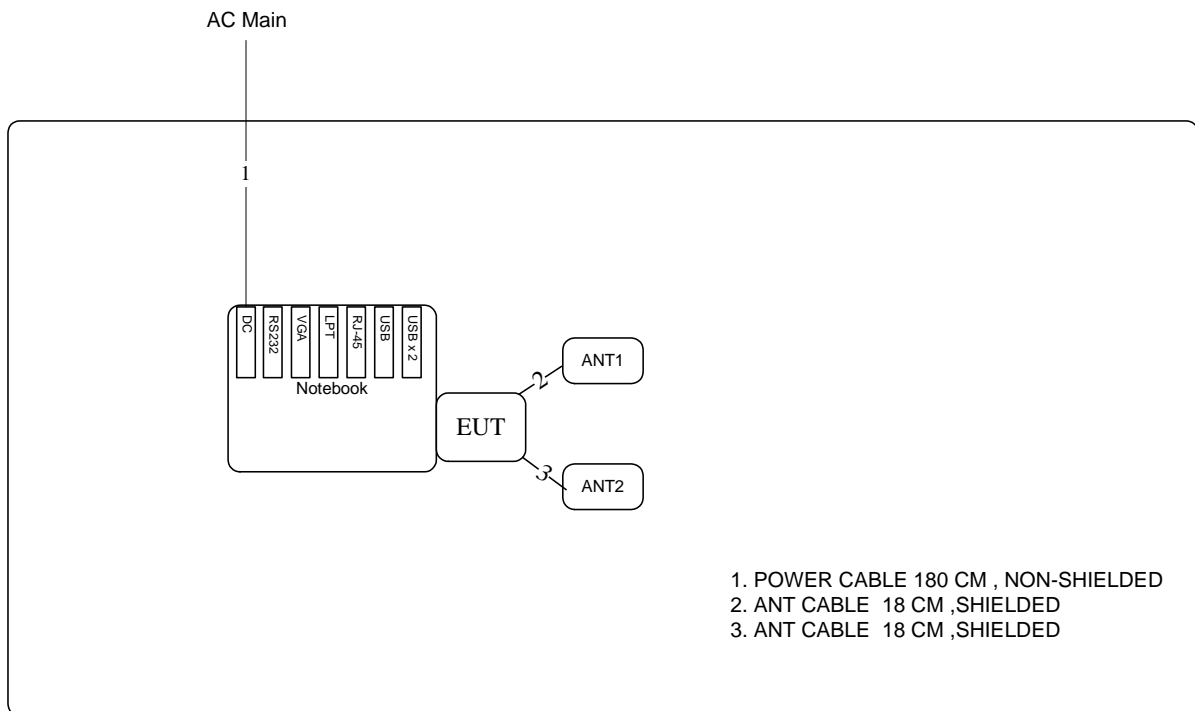

Test Configuration: above 1GHz / Mode 2

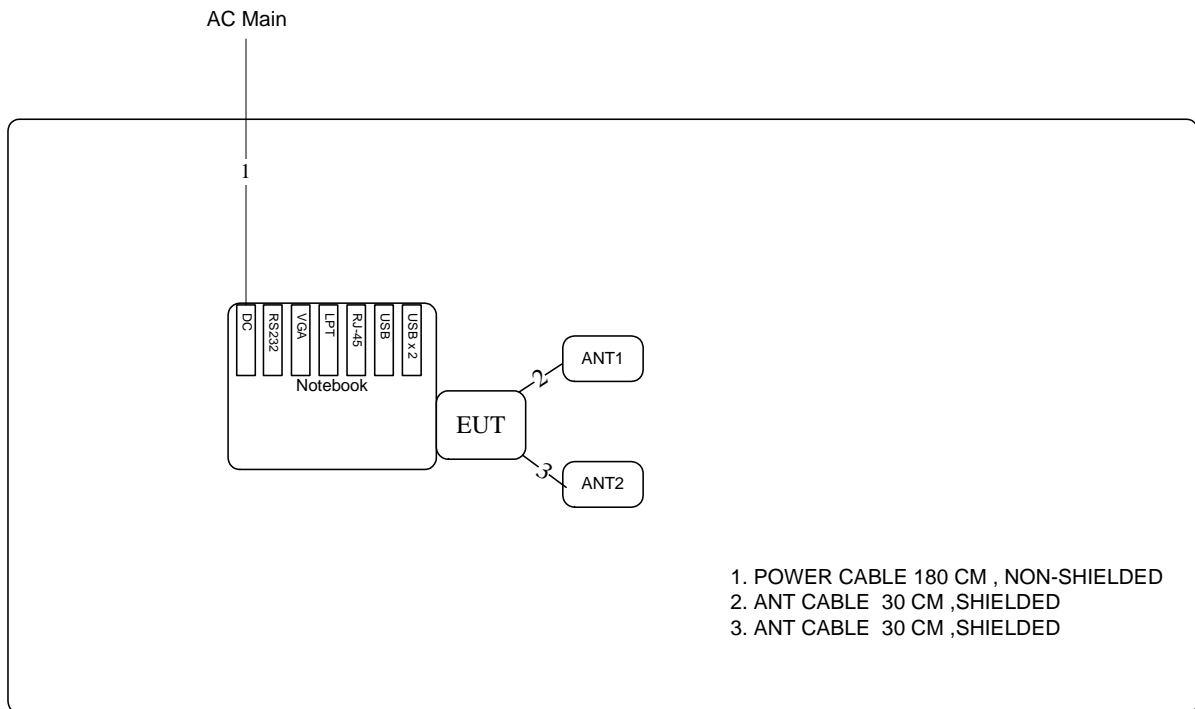

3.9.2. AC Power Line Conduction Emissions Test Configuration

Test Mode : Mode 1

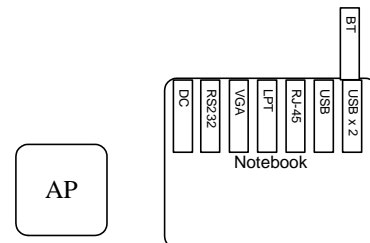
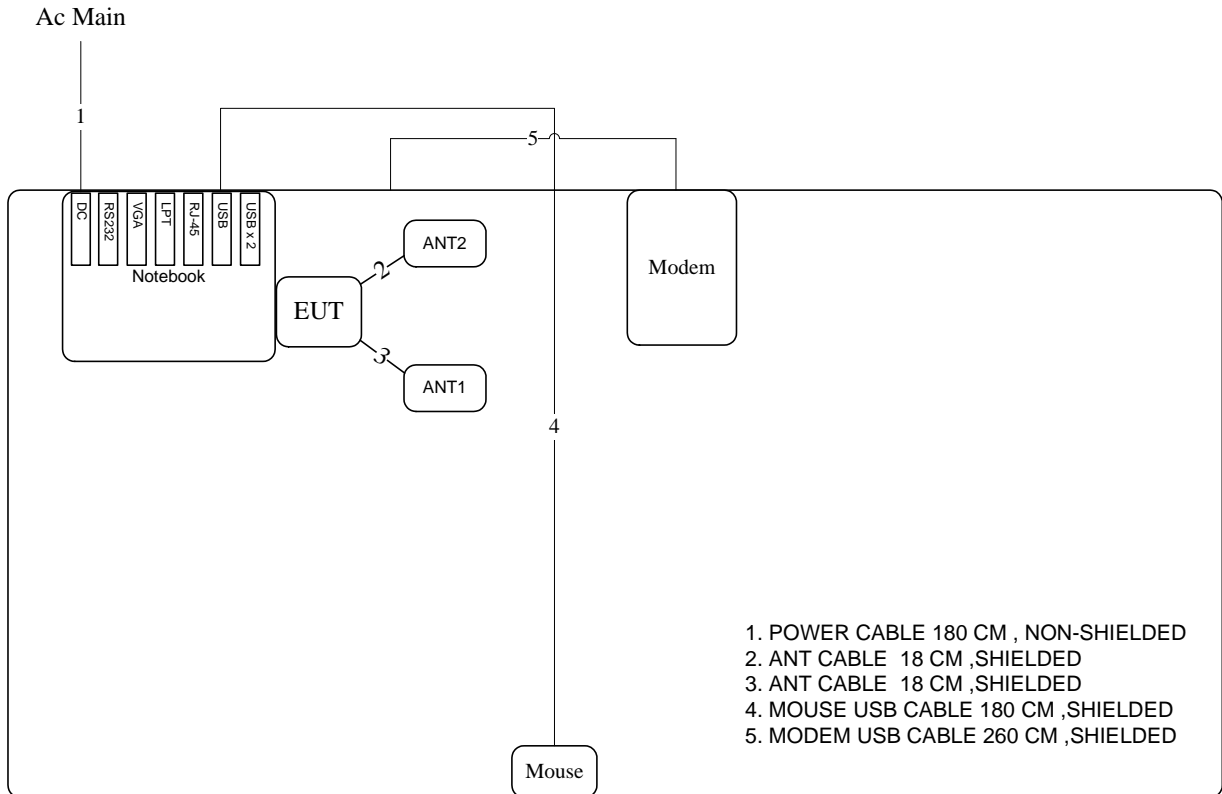

Test Mode : Mode 2

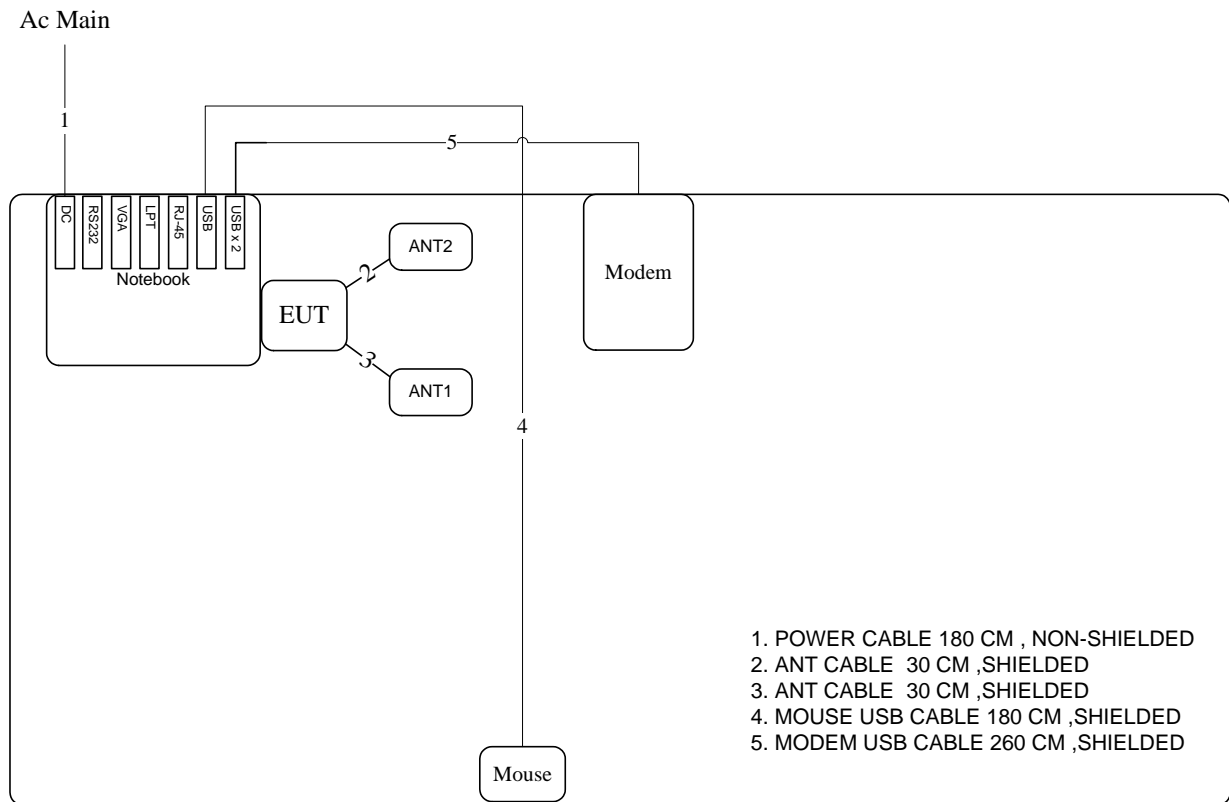

1. POWER CABLE 180 CM , NON-SHIELDED
2. ANT CABLE 30 CM ,SHIELDED
3. ANT CABLE 30 CM ,SHIELDED
4. MOUSE USB CABLE 180 CM ,SHIELDED
5. MODEM USB CABLE 260 CM ,SHIELDED

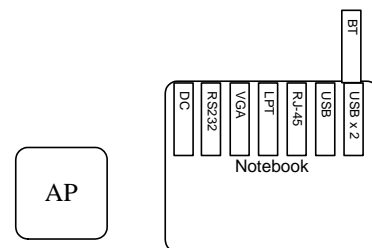

4. TEST RESULT

4.1. AC Power Line Conducted Emissions Measurement

4.1.1. Limit

For a Low-power Radio-frequency Device which is designed to be connected to the AC power line, the radio frequency voltage that is conducted back onto the AC power line on any frequency or frequencies within the band 150 kHz to 30 MHz shall not exceed below limits table.

Frequency (MHz)	QP Limit (dBuV)	AV Limit (dBuV)
0.15~0.5	66~56	56~46
0.5~5	56	46
5~30	60	50

4.1.2. Measuring Instruments and Setting

Please refer to section 5 of equipments list in this report. The following table is the setting of the receiver.

Receiver Parameters	Setting
Attenuation	10 dB
Start Frequency	0.15 MHz
Stop Frequency	30 MHz
IF Bandwidth	9 KHz

4.1.3. Test Procedures

1. Configure the EUT according to ANSI C63.10. The EUT or host of EUT has to be placed 0.4 meter far from the conducting wall of the shielding room and at least 80 centimeters from any other grounded conducting surface.
2. Connect EUT or host of EUT to the power mains through a line impedance stabilization network (LISN).
3. All the support units are connected to the other LISNs. The LISN should provide 50uH/50ohms coupling impedance.
4. The frequency range from 150 KHz to 30 MHz was searched.
5. Set the test-receiver system to Peak Detect Function and Specified Bandwidth with Maximum Hold Mode.
6. The measurement has to be done between each power line and ground at the power terminal.

4.1.4. Test Setup Layout

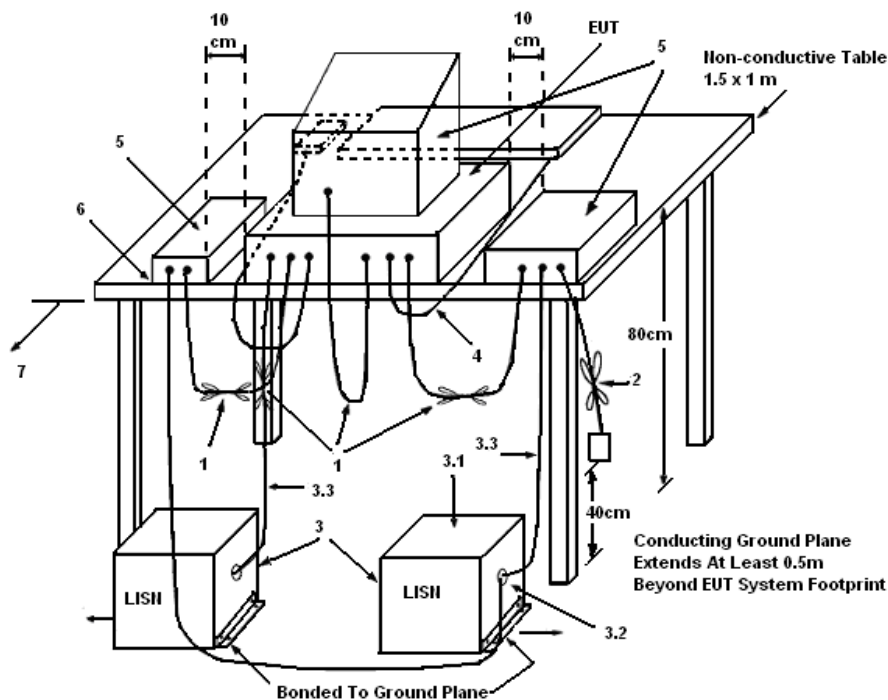

LEGEND:

- (1) Interconnecting cables that hang closer than 40 cm to the ground plane shall be folded back and forth in the center forming a bundle 30 to 40 cm long.
- (2) I/O cables that are not connected to a peripheral shall be bundled in the center. The end of the cable may be terminated, if required, using the correct terminating impedance. The overall length shall not exceed 1 m.
- (3) EUT connected to one LISN. Unused LISN measuring port connectors shall be terminated in 50 Ω . LISN can be placed on top of, or immediately beneath, reference ground plane.
 - (3.1) All other equipment powered from additional LISN(s).
 - (3.2) Multiple outlet strip can be used for multiple power cords of non-EUT equipment.
 - (3.3) LISN at least 80 cm from nearest part of EUT chassis.
- (4) Cables of hand-operated devices, such as keyboards, mice, etc., shall be placed as for normal use.
- (5) Non-EUT components of EUT system being tested.
- (6) Rear of EUT, including peripherals, shall all be aligned and flush with rear of tabletop.
- (7) Rear of tabletop shall be 40 cm removed from a vertical conducting plane that is bonded to the ground plane.

4.1.5. Test Deviation

There is no deviation with the original standard.

4.1.6. EUT Operation during Test

The EUT was placed on the test table and programmed in normal function.

4.1.7. Results of AC Power Line Conducted Emissions Measurement

Temperature	23°C	Humidity	65%
Test Engineer	Kane Liu	Phase	Line
Configuration	Normal Link / Mode 1		

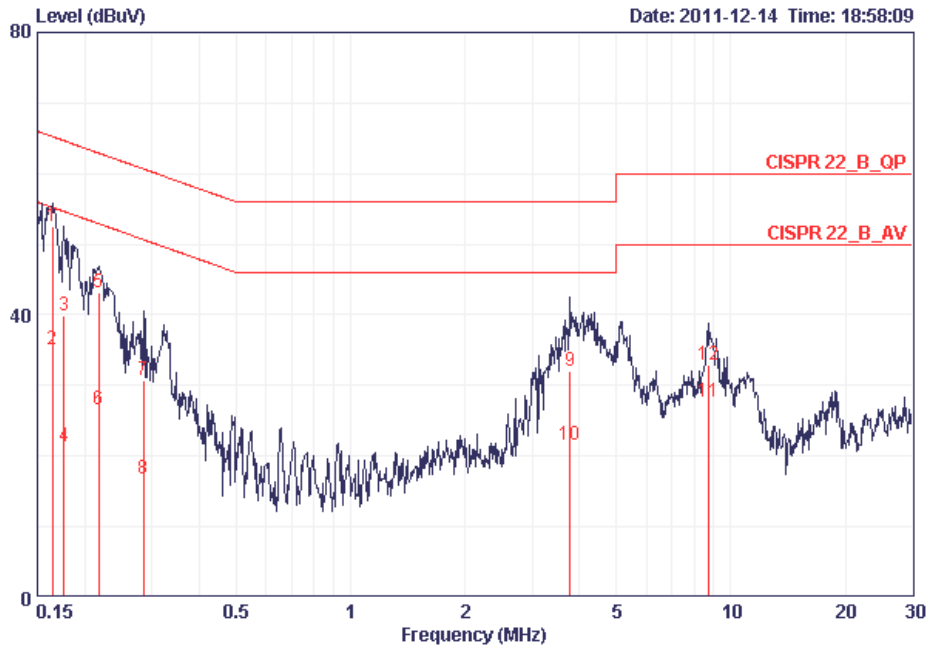

	Freq	Level	Over Limit	Limit Line	Read Level	LISN Factor	Cable Loss	Remark
	MHz	dBuV	dB	dBuV	dBuV	dB	dB	
1	0.16414	52.63	-12.62	65.25	52.36	0.07	0.20	QP
2	0.16414	35.00	-20.25	55.25	34.73	0.07	0.20	AVERAGE
3	0.17584	39.99	-24.69	64.68	39.73	0.06	0.20	QP
4	0.17584	21.42	-33.26	54.68	21.16	0.06	0.20	AVERAGE
5	0.21735	43.25	-19.67	62.92	43.00	0.05	0.20	QP
6	0.21735	26.56	-26.36	52.92	26.31	0.05	0.20	AVERAGE
7	0.28478	30.71	-29.97	60.68	30.47	0.04	0.20	QP
8	0.28478	16.72	-33.96	50.68	16.48	0.04	0.20	AVERAGE
9	3.779	32.12	-23.88	56.00	31.72	0.10	0.30	QP
10	3.779	21.68	-24.32	46.00	21.28	0.10	0.30	AVERAGE
11	8.776	27.63	-22.37	50.00	27.02	0.31	0.30	AVERAGE
12	8.776	33.01	-26.99	60.00	32.40	0.31	0.30	QP

Temperature	23°C	Humidity	65%
Test Engineer	Kane Liu	Phase	Neutral
Configuration	Normal Link / Mode 1		

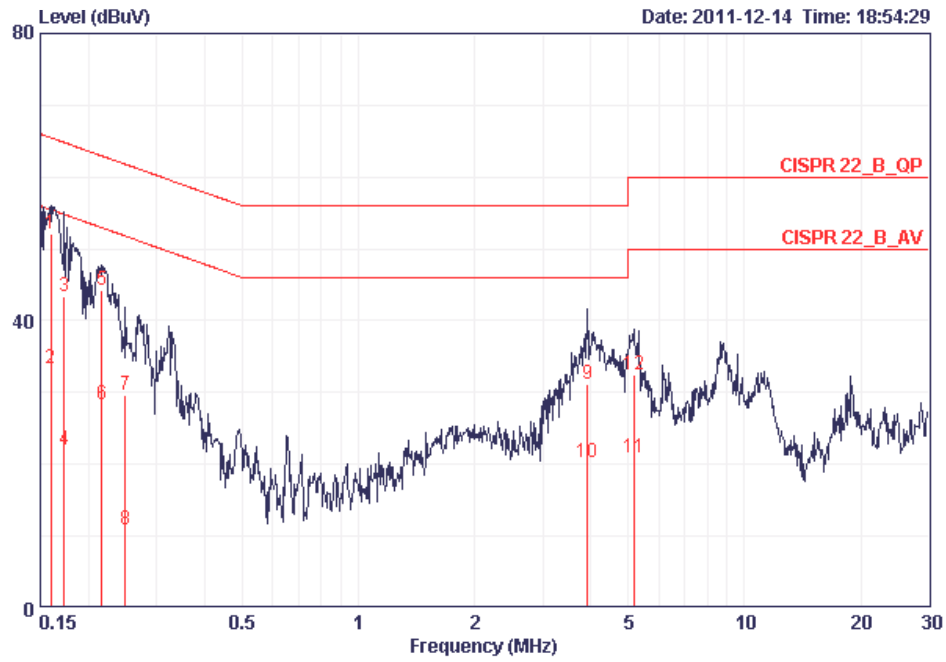

	Freq	Level	Over Limit	Limit Line	Read Level	LISN Factor	Cable Loss	Remark
	MHz	dBuV	dB	dBuV	dBuV	dB	dB	
1	0.15985	52.04	-13.43	65.47	51.74	0.10	0.20	QP
2	0.15985	33.26	-22.21	55.47	32.96	0.10	0.20	AVERAGE
3	0.17307	43.31	-21.50	64.81	43.02	0.09	0.20	QP
4	0.17307	21.98	-32.83	54.81	21.69	0.09	0.20	AVERAGE
5	0.21620	44.35	-18.61	62.96	44.07	0.08	0.20	QP
6	0.21620	28.40	-24.56	52.96	28.12	0.08	0.20	AVERAGE
7	0.24945	29.73	-32.05	61.78	29.45	0.08	0.20	QP
8	0.24945	10.87	-40.91	51.78	10.59	0.08	0.20	AVERAGE
9	3.922	31.21	-24.79	56.00	30.77	0.14	0.30	QP
10	3.922	20.23	-25.77	46.00	19.79	0.14	0.30	AVERAGE
11	5.166	20.91	-29.09	50.00	20.40	0.21	0.30	AVERAGE
12	5.166	32.39	-27.61	60.00	31.88	0.21	0.30	QP

Note: Level = Read Level + LISN Factor + Cable Loss.

Temperature	23°C	Humidity	65%
Test Engineer	Kane Liu	Phase	Line
Configuration	Normal Link / Mode 2		

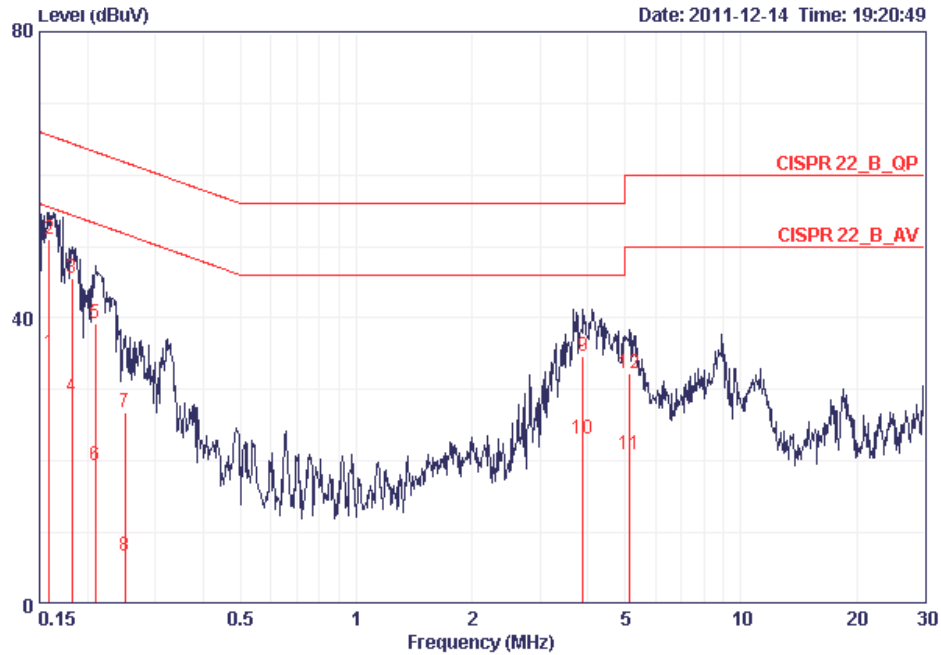

	Freq	Level	Over Limit	Limit Line	Read Level	LISN Factor	Cable Loss	Remark
	MHz	dBuV	dB	dBuV	dBuV	dB	dB	
1	0.15900	35.00	-20.52	55.52	34.73	0.07	0.20	AVERAGE
2	0.15900	50.93	-14.59	65.52	50.66	0.07	0.20	QP
3	0.18249	45.55	-18.82	64.37	45.29	0.06	0.20	QP
4	0.18249	28.98	-25.39	54.37	28.72	0.06	0.20	AVERAGE
5	0.20944	39.13	-24.10	63.23	38.88	0.05	0.20	QP
6	0.20944	19.48	-33.75	53.23	19.23	0.05	0.20	AVERAGE
7	0.25078	26.79	-34.94	61.73	26.55	0.04	0.20	QP
8	0.25078	6.70	-45.03	51.73	6.46	0.04	0.20	AVERAGE
9	3.881	34.70	-21.30	56.00	34.30	0.10	0.30	QP
10	3.881	23.19	-22.81	46.00	22.79	0.10	0.30	AVERAGE
11	5.139	21.01	-28.99	50.00	20.54	0.17	0.30	AVERAGE
12	5.139	32.35	-27.65	60.00	31.88	0.17	0.30	QP

Temperature	23°C	Humidity	65%
Test Engineer	Kane Liu	Phase	Neutral
Configuration	Normal Link / Mode 2		

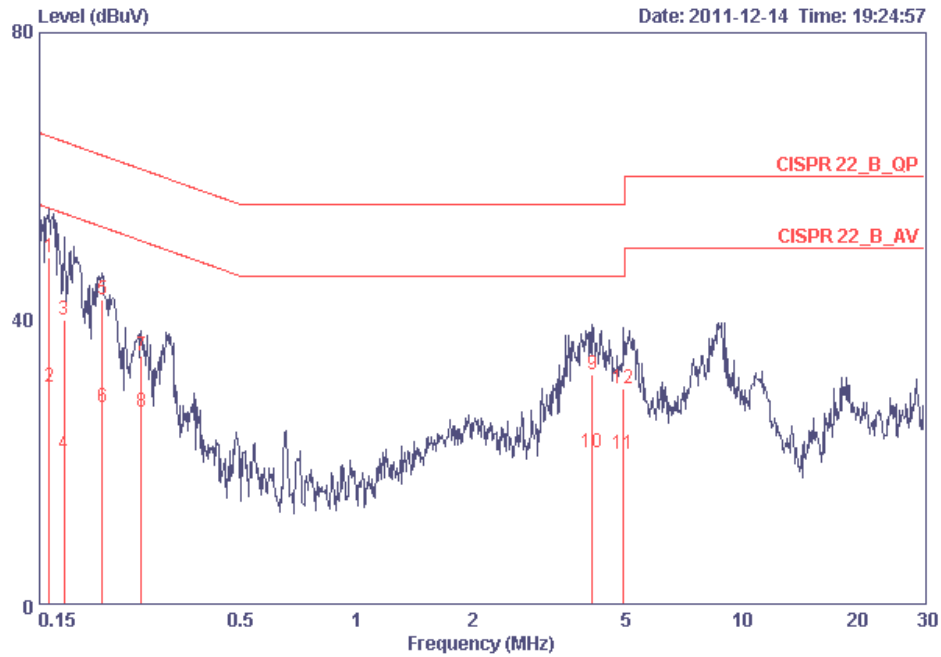

	Freq	Level	Over Limit	Limit Line	Read Level	LISN Factor	Cable Loss	Remark
	MHz	dBuV	dB	dBuV	dBuV	dB	dB	
1 @	0.15900	48.62	-16.90	65.52	48.32	0.10	0.20	QP
2	0.15900	30.53	-24.99	55.52	30.23	0.10	0.20	AVERAGE
3	0.17399	39.79	-24.98	64.77	39.50	0.09	0.20	QP
4	0.17399	21.16	-33.61	54.77	20.87	0.09	0.20	AVERAGE
5	0.21851	42.77	-20.11	62.88	42.49	0.08	0.20	QP
6	0.21851	27.79	-25.09	52.88	27.51	0.08	0.20	AVERAGE
7	0.27587	34.84	-26.10	60.94	34.56	0.08	0.20	QP
8	0.27587	26.94	-24.00	50.94	26.66	0.08	0.20	AVERAGE
9	4.114	32.29	-23.71	56.00	31.84	0.15	0.30	QP
10	4.114	21.26	-24.74	46.00	20.81	0.15	0.30	AVERAGE
11	4.952	21.18	-24.82	46.00	20.68	0.20	0.30	AVERAGE
12	4.952	30.40	-25.60	56.00	29.90	0.20	0.30	QP

Note:

$$\text{Level} = \text{Read Level} + \text{LISN Factor} + \text{Cable Loss}$$

4.2. Maximum Peak Output Power Measurement

4.2.1. Limit

For frequency hopping systems operating in the 2400-2483.5 MHz band employing at least 75 non-overlapping hopping channels, the limit for peak output power is 1Watt (30dBm). For all other frequency hopping systems in the 2400-2483.5 MHz band: 0.125 watts (21dBm). The limited has to be reduced by the amount in dB that the gain of the antenna exceed 6dBi. In case of point-to-point operation, the limit has to be reduced by 1dB for every 3dB that the directional gain of the antenna exceeds 6dBi.

4.2.2. Measuring Instruments and Setting

Please refer to section 5 of equipments list in this report. The following table is the setting of the power meter.

Power Meter Parameter	Setting
Filter No.	Auto
Measurement time	0.135 s ~ 26 s
Used Peak Sensor	MA2411B

4.2.3. Test Procedures

1. The transmitter output (antenna port) was connected to the power meter.
2. Turn on the EUT and power meter and then record the peak power value.
3. Repeat above procedures on all channels needed to be tested.

4.2.4. Test Setup Layout

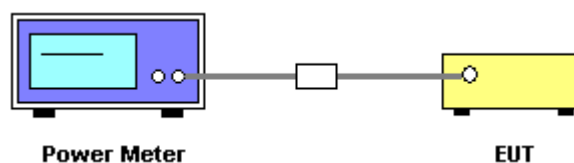

4.2.5. Test Deviation

There is no deviation with the original standard.

4.2.6. EUT Operation during Test

The EUT was programmed to be in continuously transmitting mode.

4.2.7. Test Result of Maximum Peak Output Power.

For Bluetooth 2.1 + EDR :

Temperature	25°C	Humidity	56%
Test Engineer	Sean Ku	Configurations	8DPSK / Chain 2
Test Date	Dec. 07, 2011		

Channel	Frequency	Conducted Power (dBm)	Max. Limit (dBm)	Result
0	2402 MHz	6.69	21.00	Complies
39	2441 MHz	7.63	21.00	Complies
78	2480 MHz	8.52	21.00	Complies

For Bluetooth 4.0 :

Temperature	25°C	Humidity	56%
Test Engineer	Sean Ku	Configurations	GFSK / Chain 2
Test Date	Dec. 07, 2011		

Channel	Frequency	Conducted Power (dBm)	Max. Limit (dBm)	Result
0	2402 MHz	7.90	21.00	Complies
19	2440 MHz	9.36	21.00	Complies
39	2480 MHz	9.88	21.00	Complies

4.3. Average Output Power Measurement

4.3.1. Measuring Instruments and Setting

Please refer to section 5 of equipments list in this report. The following table is the setting of the power meter.

Power Meter Parameter	Setting
Bandwidth	50MHz bandwidth is greater than the EUT emission bandwidth
Detector	Average

4.3.2. Test Procedures

Spectrum Parameter	Setting
RF Output Power Method	<input checked="" type="checkbox"/> ANSI C63.10 clause 6.10.2.1 (a) power meter method
RF Output Power Method	<input type="checkbox"/> ANSI C63.10 clause 6.10.2.1 (b) channel integration method
RF Output Power Method	<input type="checkbox"/> ANSI C63.10 clause 6.10.3.1 Method 1 - spectral trace averaging
RF Output Power Method	<input type="checkbox"/> ANSI C63.10 clause 6.10.3.2 Method 2 - zero-span mode with trace averaging

4.3.3. Test Setup Layout

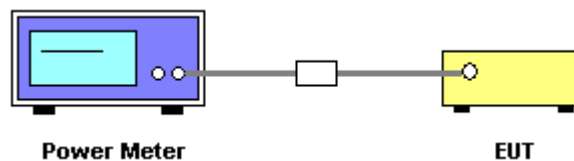

4.3.4. Test Deviation

There is no deviation with the original standard.

4.3.5. EUT Operation during Test

The EUT was programmed to be in continuously transmitting mode.

4.3.6. Test Result of Average Output Power

For Bluetooth 2.1 + EDR :

Temperature	25°C	Humidity	56%
Test Engineer	Sean Ku	Configurations	8DPSK / Chain 2
Test Date	Dec. 07, 2011		

Channel	Frequency	Average Conducted Power (dBm)
0	2402 MHz	0.77
39	2441 MHz	1.94
78	2480 MHz	3.21

For Bluetooth 4.0 :

Temperature	25°C	Humidity	56%
Test Engineer	Sean Ku	Configurations	GFSK / Chain 2
Test Date	Dec. 07, 2011		

Channel	Frequency	Average Conducted Power (dBm)
0	2402 MHz	5.39
19	2440 MHz	5.35
39	2480 MHz	6.55

4.4. Hopping Channel Separation Measurement

4.4.1. Limit

Frequency hopping systems shall have hopping channel carrier frequencies separated by a minimum of 25 kHz or the 20 dB bandwidth of the hopping channel, whichever is greater. Alternatively, frequency hopping systems operating in the 2400-2483.5 MHz band may have hopping channel carrier frequencies that are separated by 25 kHz or two-thirds of the 20 dB bandwidth of the hopping channel, whichever is greater.

4.4.2. Measuring Instruments and Setting

Please refer to section 5 of equipments list in this report. The following table is the setting of spectrum analyzer.

Spectrum Parameter	Setting
Attenuation	Auto
Span Frequency	> Measurement Bandwidth or Channel Separation
RB	30 kHz (20dB Bandwidth) / 100 kHz (Channel Separation)
VB	100 kHz (20dB Bandwidth) / 300 kHz (Channel Separation)
Detector	Peak
Trace	Max Hold
Sweep Time	Auto

4.4.3. Test Procedures

1. The transmitter output (antenna port) was connected to the spectrum analyzer in peak hold mode.
2. The resolution bandwidth of 30 kHz and the video bandwidth of 100 kHz were utilized for 20 dB bandwidth measurement.
3. The resolution bandwidth of 100 kHz and the video bandwidth of 300 kHz were utilized for channel separation measurement.

4.4.4. Test Setup Layout

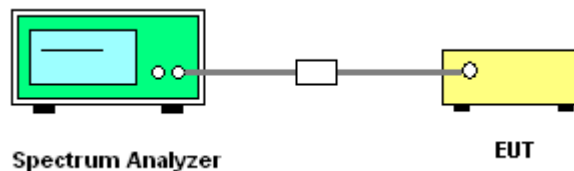

4.4.5. Test Deviation

There is no deviation with the original standard.

4.4.6. EUT Operation during Test

The EUT was programmed to be in continuously transmitting mode.

4.4.7. Test Result of Hopping Channel Separation

For Bluetooth 2.1 + EDR :

Temperature	25°C	Humidity	56%
Test Engineer	Sean Ku	Configurations	8DPSK / Chain 2
Test Date	Dec. 07, 2011		

Frequency	Ch. Separation (MHz)	20dB Bandwidth (MHz)	2/3 of 20dB Bandwidth (MHz)	99% Occupied Bandwidth (MHz)	Result
2402 MHz	1.00	1.2960	0.864	1.1680	Complies
2441 MHz	1.00	1.2960	0.864	1.1760	Complies
2480 MHz	1.00	1.2960	0.864	1.1920	Complies

Ch. Separation Limits: >20dB bandwidth or >2/3 of 20dB bandwidth

For Bluetooth 4.0 :

Temperature	25°C	Humidity	56%
Test Engineer	Sean Ku	Configurations	GFSK / Chain 2
Test Date	Dec. 07, 2011		

Frequency	Ch. Separation (MHz)	20dB Bandwidth (MHz)	2/3 of 20dB Bandwidth (MHz)	99% Occupied Bandwidth (MHz)	Result
2402 MHz	1.00	1.0941	0.7294	1.0246	Complies
2440 MHz	1.00	1.1080	0.738666667	1.0246	Complies
2480 MHz	1.00	1.0990	0.732666667	1.0210	Complies

Ch. Separation Limits: >20dB bandwidth or >2/3 of 20dB bandwidth

For Bluetooth 2.1 + EDR :

20 dB Bandwidth Plot on Channel 0 / 2402 MHz / Chain 2

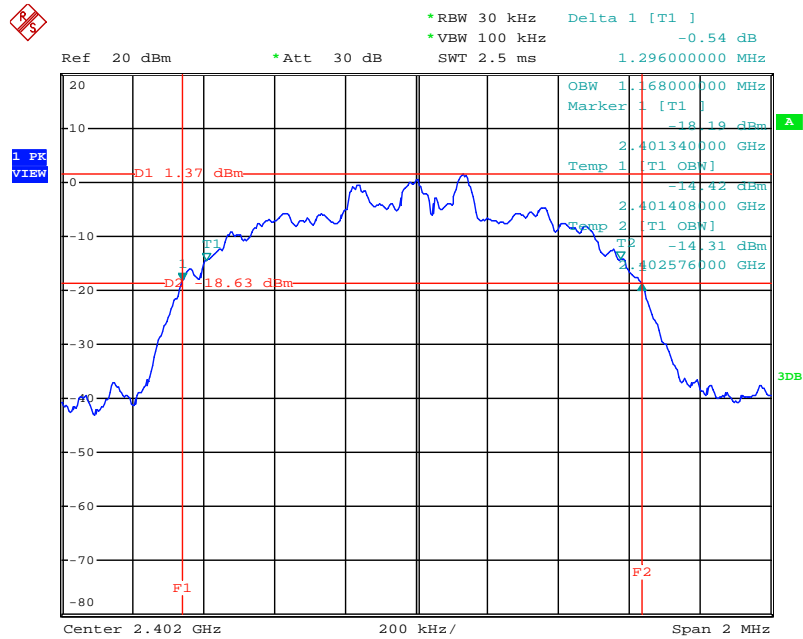

Date: 7.DEC.2011 11:59:25

20 dB Bandwidth Plot on Channel 39 / 2441 MHz / Chain 2

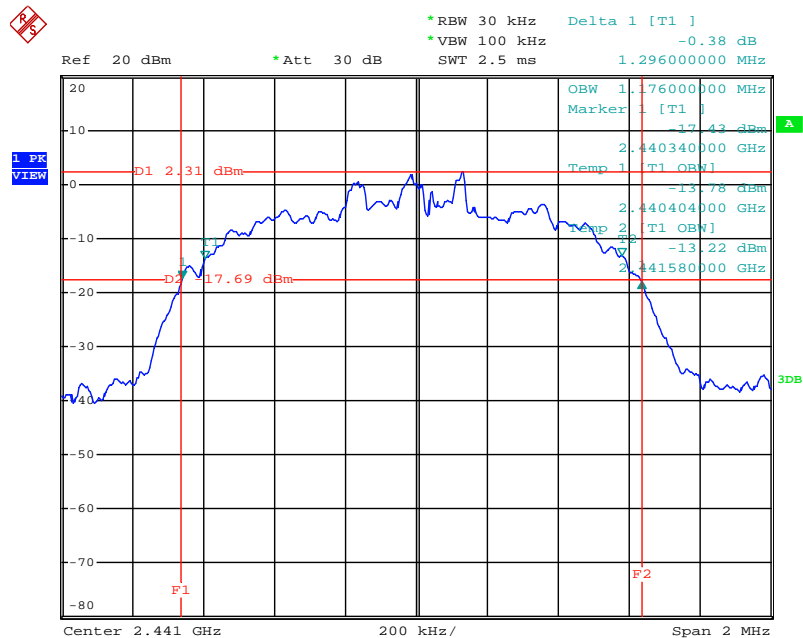

Date: 7.DEC.2011 11:57:24

20 dB Bandwidth Plot on Channel 78 / 2480 MHz / Chain 2

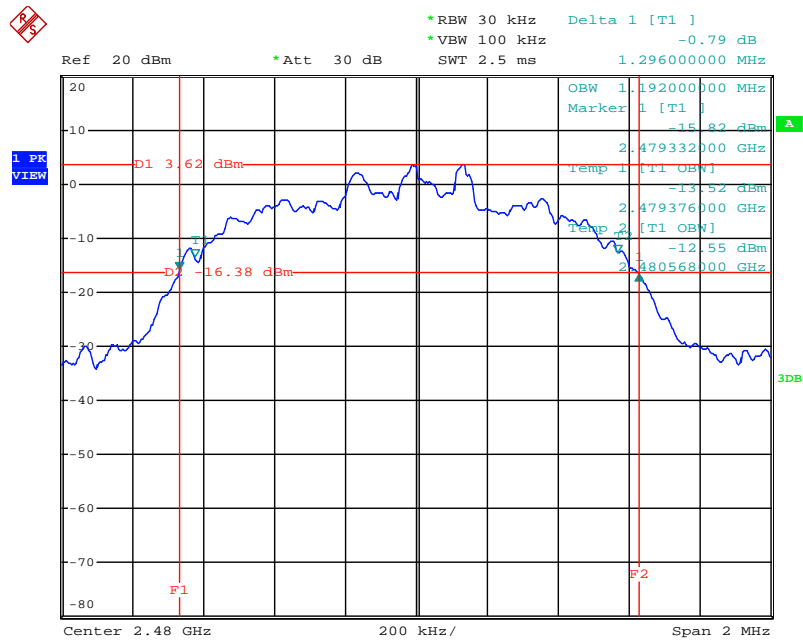

Date: 7.DEC.2011 12:01:16

For Bluetooth 4.0 :

20 dB Bandwidth Plot on Channel 0 / 2402 MHz / Chain 2

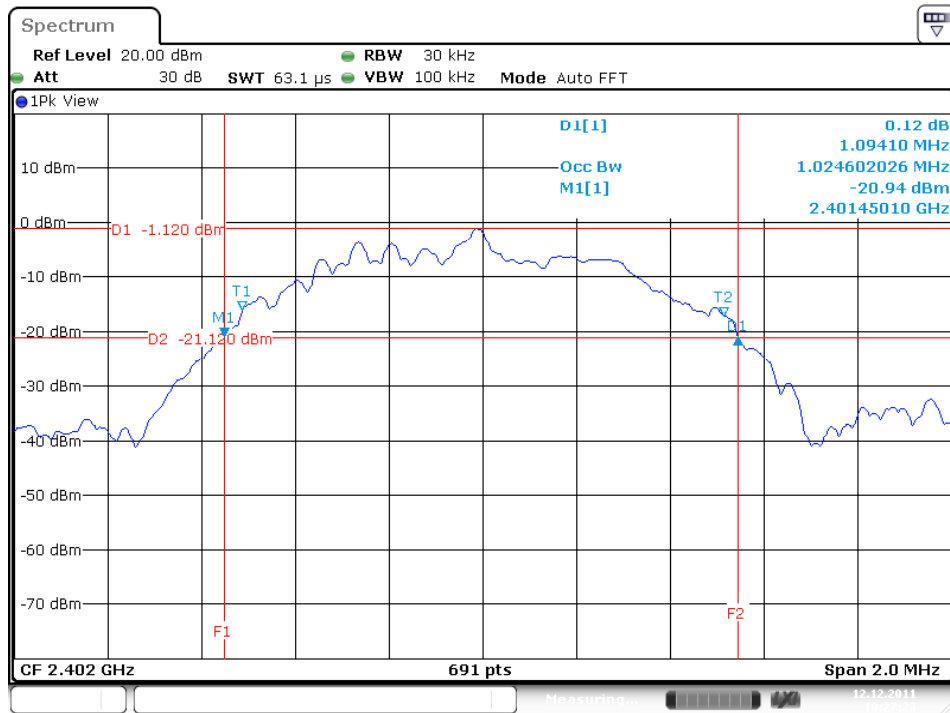

20 dB Bandwidth Plot on Channel 19 / 2440 MHz / Chain 2

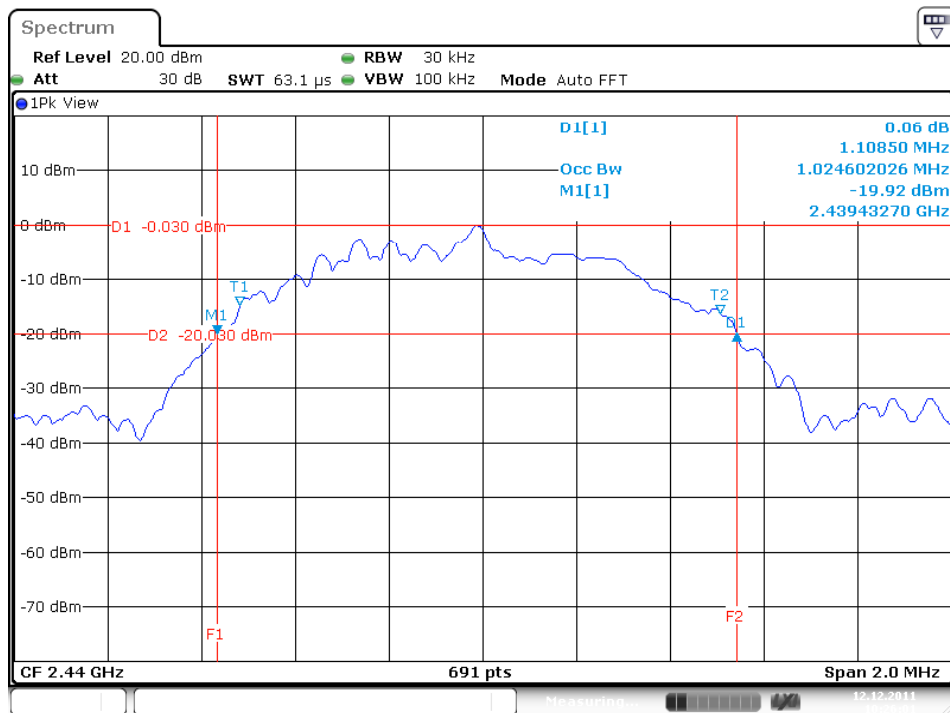

20 dB Bandwidth Plot on Channel 39 / 2480 MHz / Chain 2

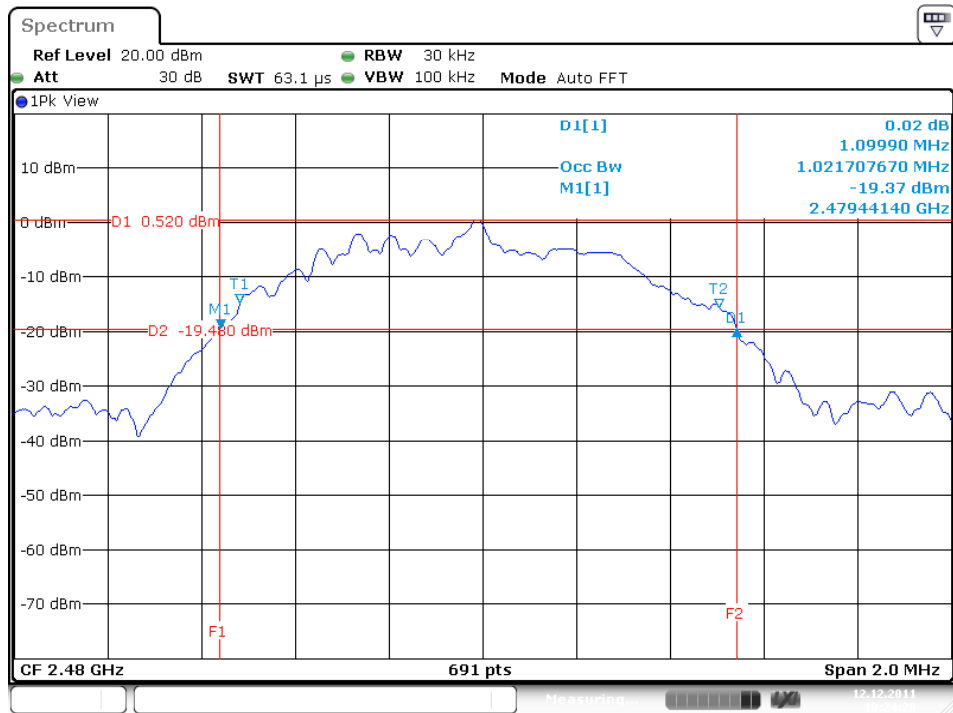

Date: 12.DEC.2011 10:24:28

4.5. Number of Hopping Frequency Measurement

4.5.1. Limit

At least 15 hopping frequencies, and should be equally spaced.

4.5.2. Measuring Instruments and Setting

Please refer to section 5 of equipments list in this report. The following table is the setting of spectrum analyzer.

Spectrum Parameters	Setting
Attenuation	Auto
Span Frequency	> Operating Frequency Range
RB	1MHz
VB	1MHz
Detector	Peak
Trace	Max Hold
Sweep Time	Auto

4.5.3. Test Procedures

1. The transmitter output (antenna port) was connected to the spectrum analyzer in peak hold mode.
2. The resolution bandwidth of 1MHz and the video bandwidth of 1MHz were utilized.
3. Observe frequency hopping in 2400MHz~2483.5MHz, there are at least 75 non-overlapping channels.

4.5.4. Test Setup Layout

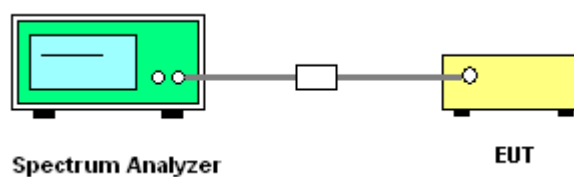

4.5.5. Test Deviation

There is no deviation with the original standard.

4.5.6. EUT Operation during Test

The EUT was programmed to be in continuously transmitting mode.

4.5.7. Test Result of Number of Hopping Frequency

For Bluetooth 2.1 + EDR :

Temperature	25°C	Humidity	56%
Test Engineer	Sean Ku	Configurations	8DPSK / Chain 2
Test Date	Dec. 07, 2011		

Modulation Type	Channel No.	Frequency (MHz)	Hopping Ch. (Channels)	Min. Limit (Channels)	Test Result
GFSK	0 ~ 78	2402 ~ 2480	79	75	Complies

Number of Hopping Channel Plot on Channel 0~78 / 2402 MHz ~ 2480 MHz

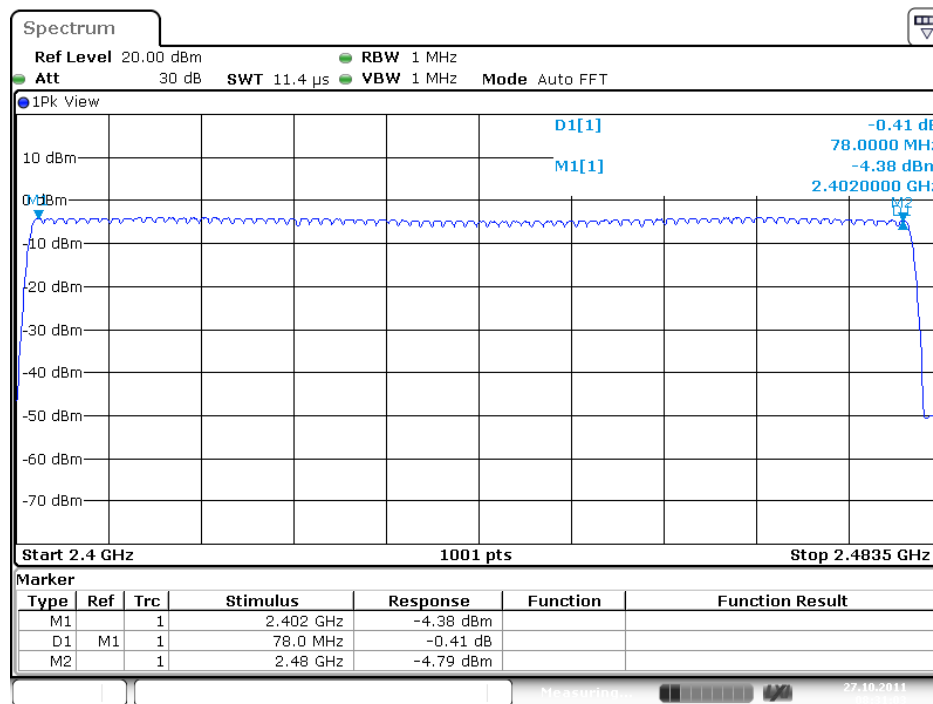

Date: 27.OCT.2011 08:31:03

Channel Separation Plot on Channel 0~1 / 2402 MHz ~ 2403MHz / Chain 2

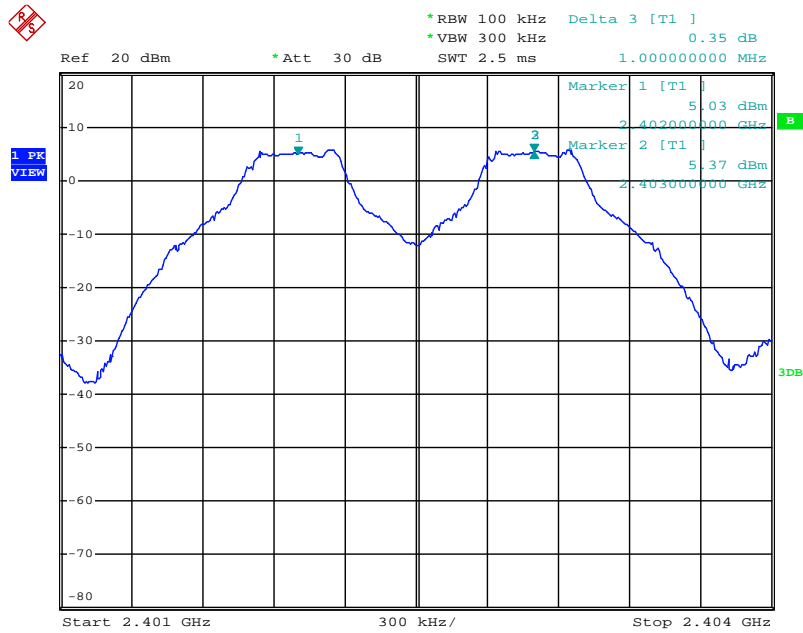

Date: 7.DEC.2011 10:43:13

Channel Separation Plot on Channel 39~40 / 2441 MHz ~ 2442MHz / Chain 2

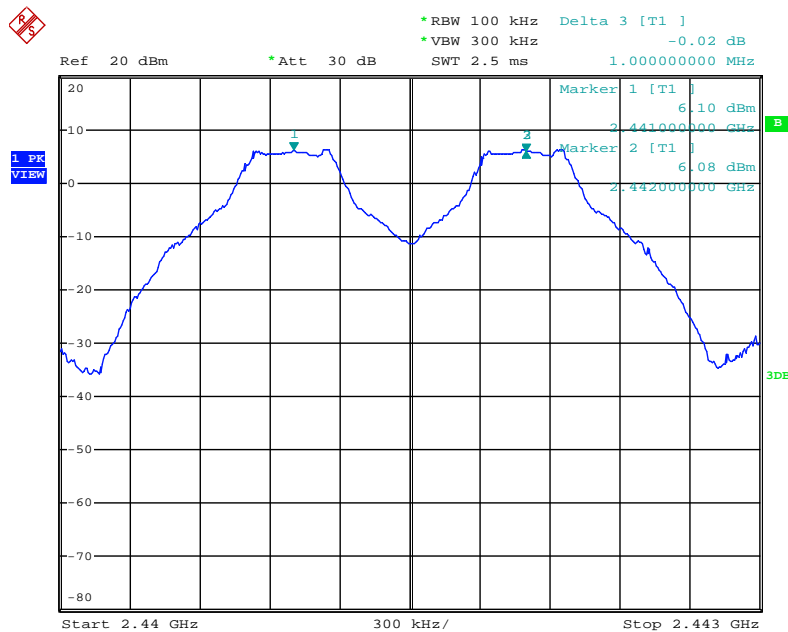

Date: 7.DEC.2011 10:45:22

Channel Separation Plot on Channel 77~78 / 2479 MHz ~ 2480 MHz / Chain 2

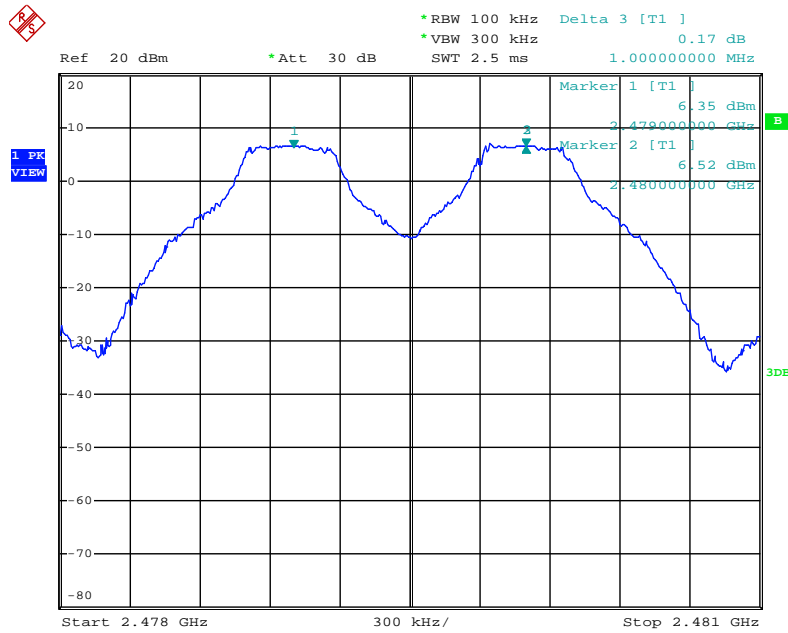

Date: 7.DEC.2011 10:47:35

For Bluetooth 4.0 :

Temperature	25°C	Humidity	56%
Test Engineer	Sean Ku	Configurations	GFSK / Chain 2
Test Date	Dec. 12, 2011		

Modulation Type	Channel No.	Frequency (MHz)	Hopping Ch. (Channels)	Min. Limit (Channels)	Test Result
GFSK	0 ~ 39	2402 ~ 2480	40	15	Complies

Number of Hopping Channel Plot on Channel 0~39 / 2402 MHz ~ 2480 MHz

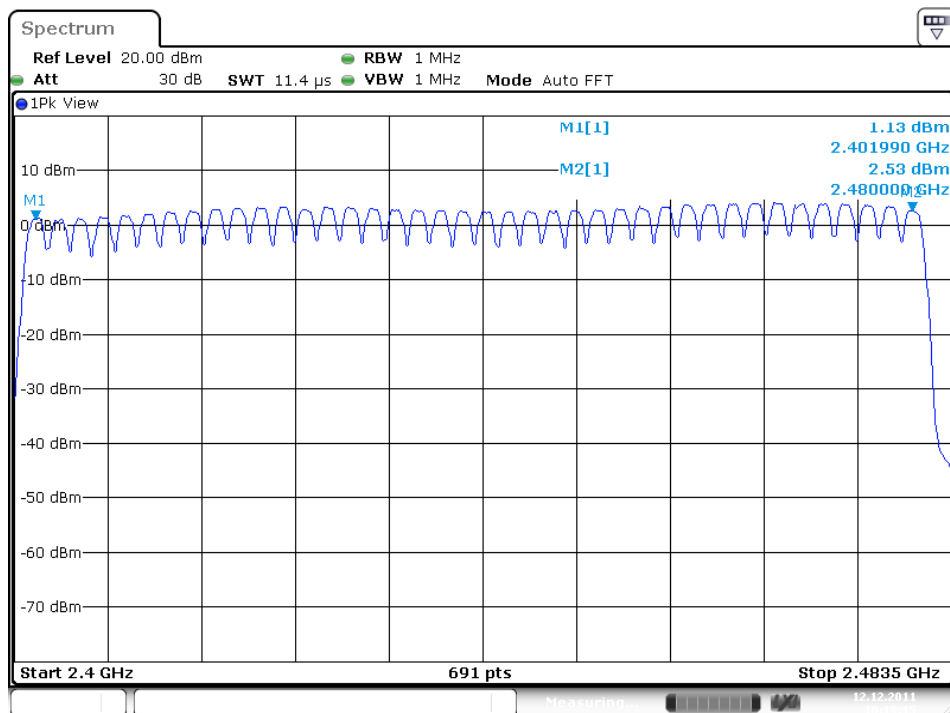

Channel Separation Plot on Channel 0~1 / 2402 MHz ~ 2404 MHz / Chain 2

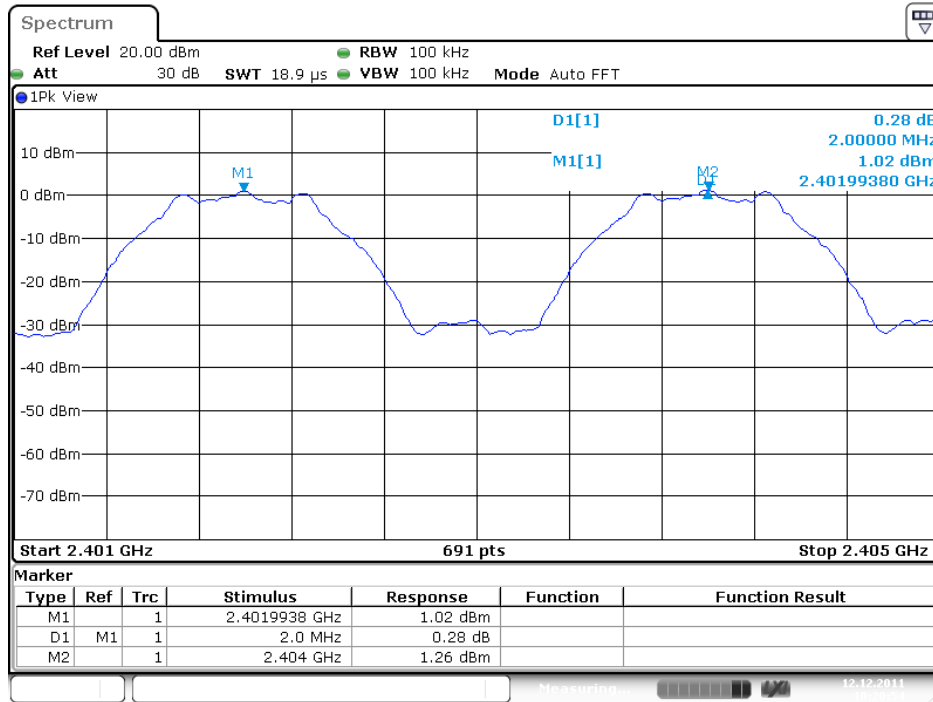

Date: 12.DEC.2011 10:20:54

Channel Separation Plot on Channel 19~20 / 2440 MHz ~ 2442 MHz / Chain 2

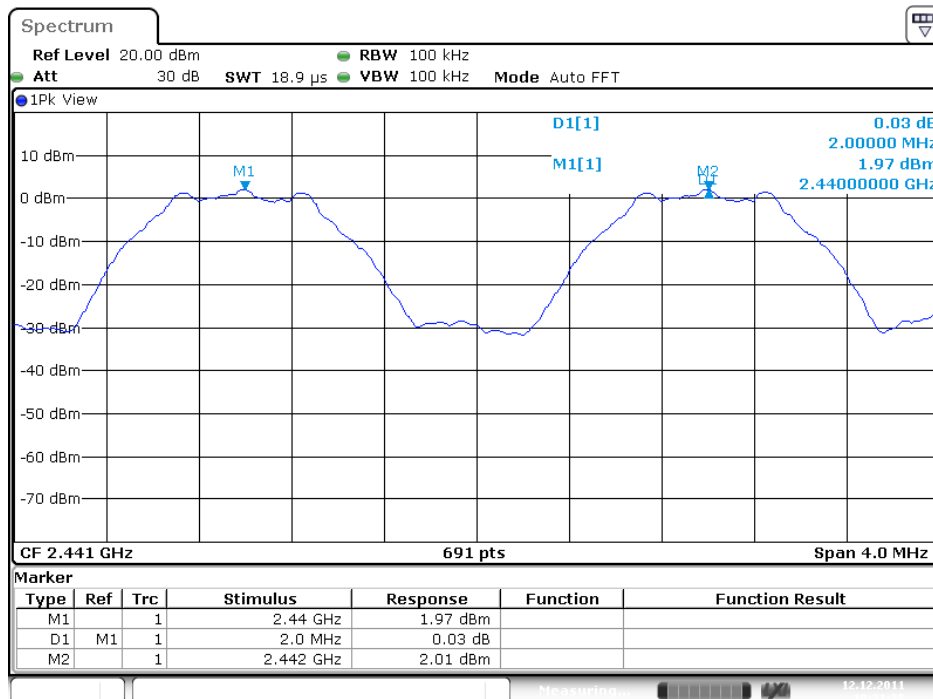

Date: 12.DEC.2011 10:21:38

Channel Separation Plot on Channel 38~39 / 2478 MHz ~ 2480 MHz / Chain 2

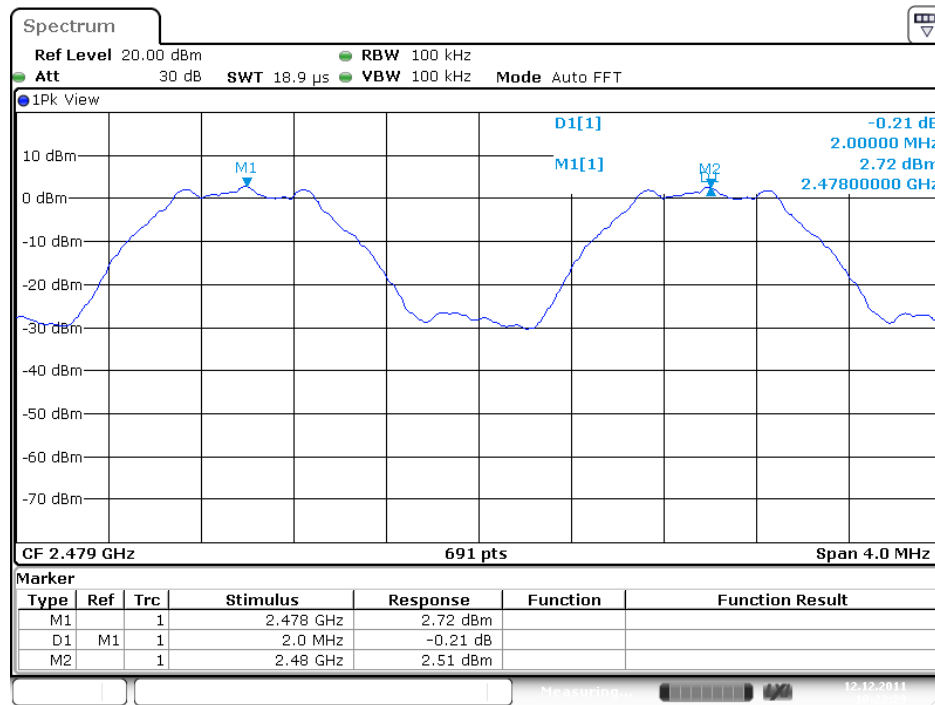

Date: 12.DEC.2011 10:22:29

4.6. Dwell Time Measurement

4.6.1. Limit

Frequency hopping systems in the 2400-2483.5 MHz band shall use at least 15 channels. The average time of occupancy on any channel shall not be greater than 0.4 seconds within a period of 0.4 seconds multiplied by the number of hopping channels employed.

4.6.2. Measuring Instruments and Setting

Please refer to section 5 of equipments list in this report. The following table is the setting of spectrum analyzer.

Spectrum Parameter	Setting
Attenuation	Auto
Span Frequency	0 MHz
RB	1000 kHz
VB	1000 kHz
Detector	Peak
Trace	Single Trigger

4.6.3. Test Procedures

1. The transmitter output (antenna port) was connected to the spectrum analyzer
2. Set RBW of spectrum analyzer to 1000kHz and VBW to 1000kHz.
3. Use a video trigger with the trigger level set to enable triggering only on full pulses.
4. Sweep Time is more than once pulse time.
5. Set the center frequency on any frequency would be measure and set the frequency span to zero span.
6. Measure the maximum time duration of one single pulse.
7. Set the EUT for 3DH5, 3DH3 and 3DH1 packet transmitting.
8. Measure the maximum time duration of one single pulse.

4.6.4. Test Setup Layout

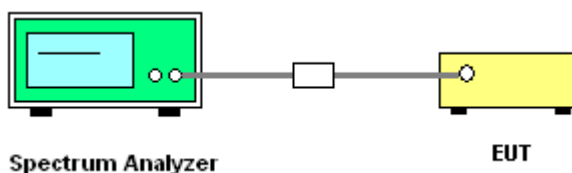

4.6.5. Test Deviation

There is no deviation with the original standard.

4.6.6. EUT Operation during Test

The EUT was programmed to be in continuously transmitting mode.

4.6.7. Test Result of Dwell Time

For Bluetooth 2.1 + EDR :

Temperature	25°C	Humidity	56%
Test Engineer	Sean Ku	Configurations	8DPSK / 3DH1, 3DH3, 3DH5
Test Date	Dec. 07, 2011		

Data Packet	Frequency (MHz)	Pulse Duration (ms)	Dwell Time (s)	Limits (s)	Test Result
3DH5	2402 MHz	2.8800	0.3072	0.4000	Complies
3DH3	2402 MHz	1.6400	0.2624	0.4000	Complies
3DH1	2402 MHz	0.3800	0.1216	0.4000	Complies
3DH5	2441 MHz	2.9100	0.3104	0.4000	Complies
3DH3	2441 MHz	1.6400	0.2624	0.4000	Complies
3DH1	2441 MHz	0.3850	0.1232	0.4000	Complies
3DH5	2480 MHz	2.8800	0.3072	0.4000	Complies
3DH3	2480 MHz	1.6400	0.2624	0.4000	Complies
3DH1	2480 MHz	0.3800	0.1216	0.4000	Complies

Remark:

Dwell Time = 79(channels) x 0.4(s) x average hopping channel x package transfer time (us)

79 channels come from the Hopping Channel number.

Average Hopping Channel = hops / sweep time

For Bluetooth 4.0 :

Temperature	25°C	Humidity	56%
Test Engineer	Sean Ku	Configurations	GFSK / DH1
Test Date	Dec. 07, 2011		

Data Packet	Frequency (MHz)	Pulse Duration (ms)	Dwell Time (s)	Limits (s)	Test Result
DH1	2402 MHz	0.3860	0.0813	0.4000	Complies
DH1	2440 MHz	0.3890	0.1229	0.4000	Complies
DH1	2480 MHz	0.3890	0.2458	0.4000	Complies

Remark:

Dwell Time = $40(\text{channels}) \times 0.4(\text{s}) \times \text{average hopping channel} \times \text{package transfer time (us)}$

40 channels come from the Hopping Channel number.

Average Hopping Channel = hops / sweep time

Dwell Time Plot on Channel 0 / 3DH5 / 2402 MHz

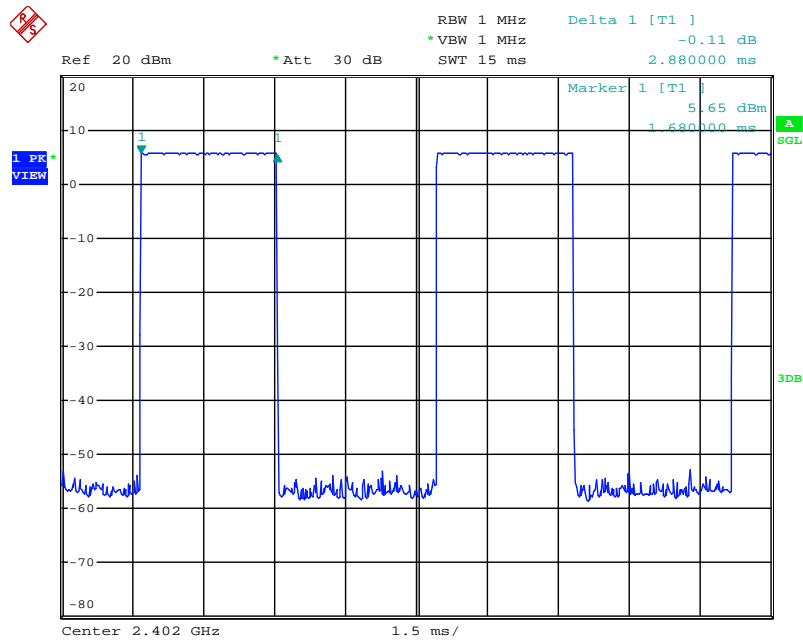

Date: 6.DEC.2011 18:00:40

Dwell Time Plot on Channel 0 / 3DH3 / 2402 MHz

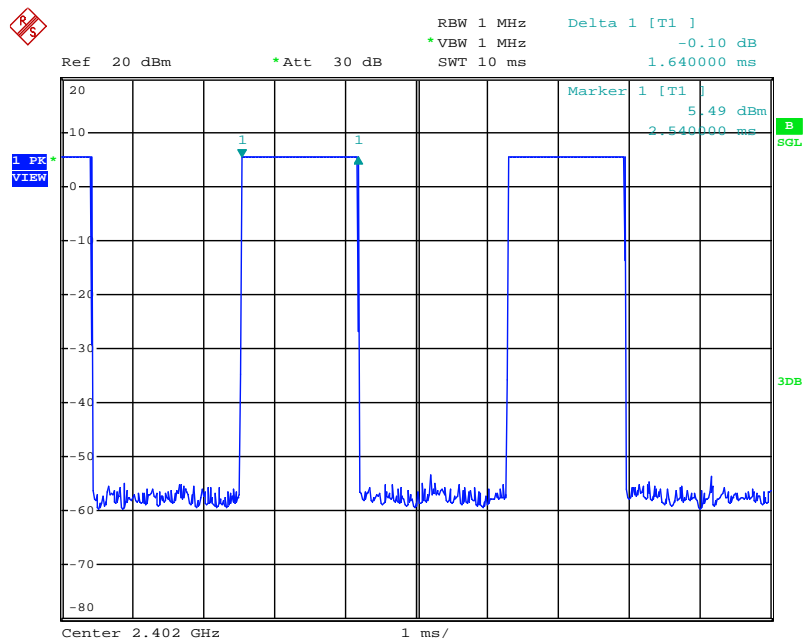

Date: 7.DEC.2011 10:32:57

Dwell Time Plot on Channel 0 / 3DH1 / 2402 MHz

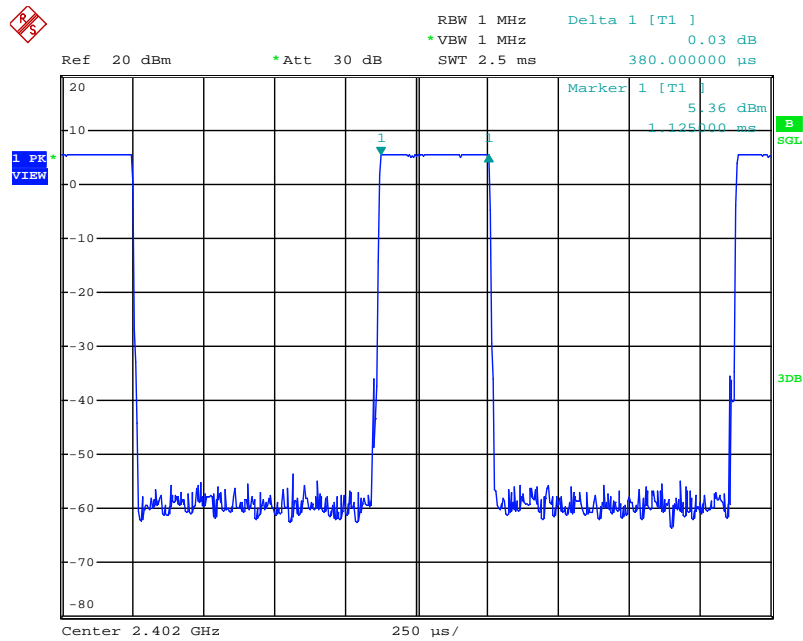

Date: 7.DEC.2011 10:35:12

Dwell Time Plot on Channel 39 / 3DH5 / 2441 MHz

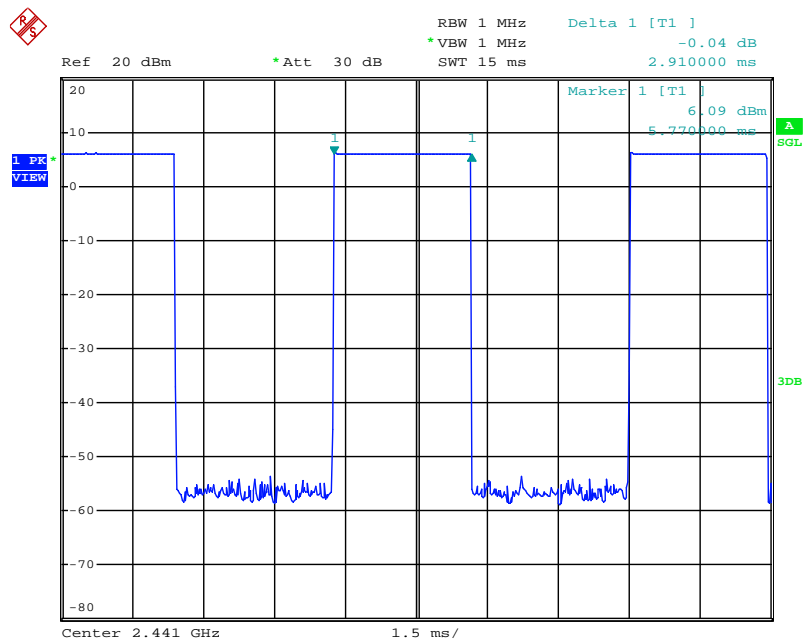

Date: 6.DEC.2011 18:02:14

Dwell Time Plot on Channel 39 / 3DH3 / 2441 MHz

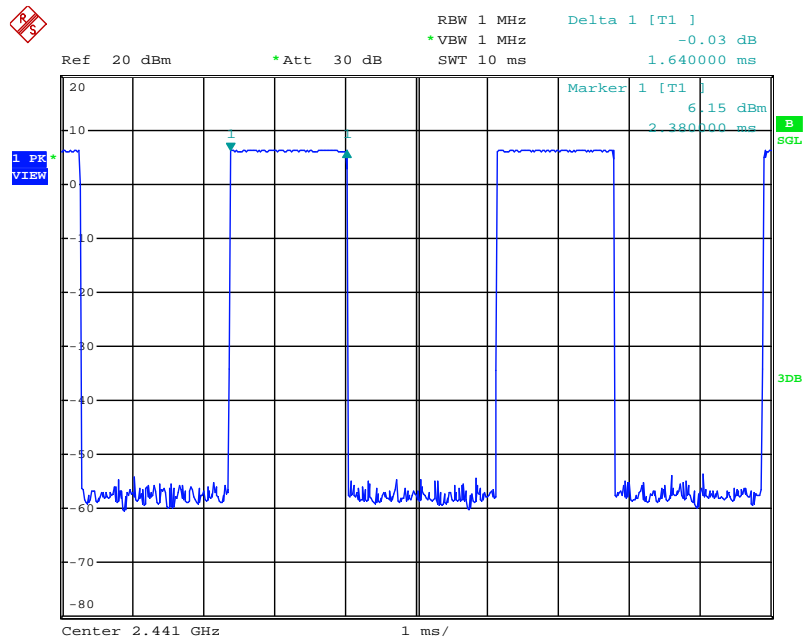

Date: 7.DEC.2011 10:31:39

Dwell Time Plot on Channel 39 / 3DH1 / 2441 MHz

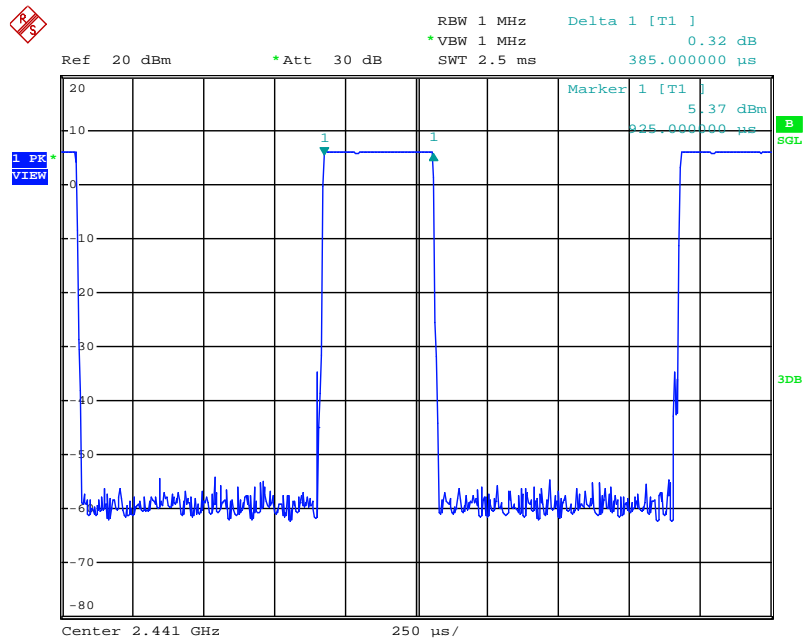

Date: 7.DEC.2011 10:36:08

Dwell Time Plot on Channel 78 / 3DH5 / 2480 MHz

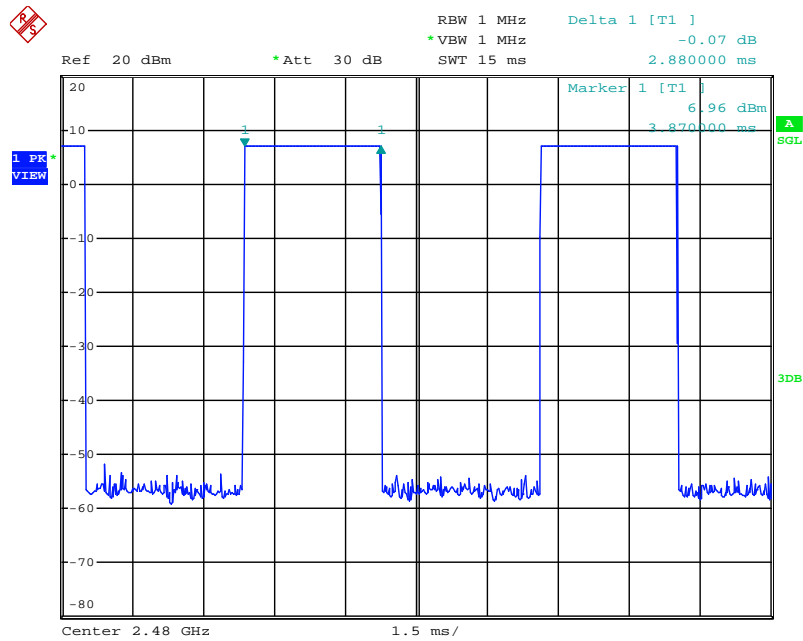

Date: 6.DEC.2011 18:03:06

Dwell Time Plot on Channel 78 / 3DH3 / 2480 MHz

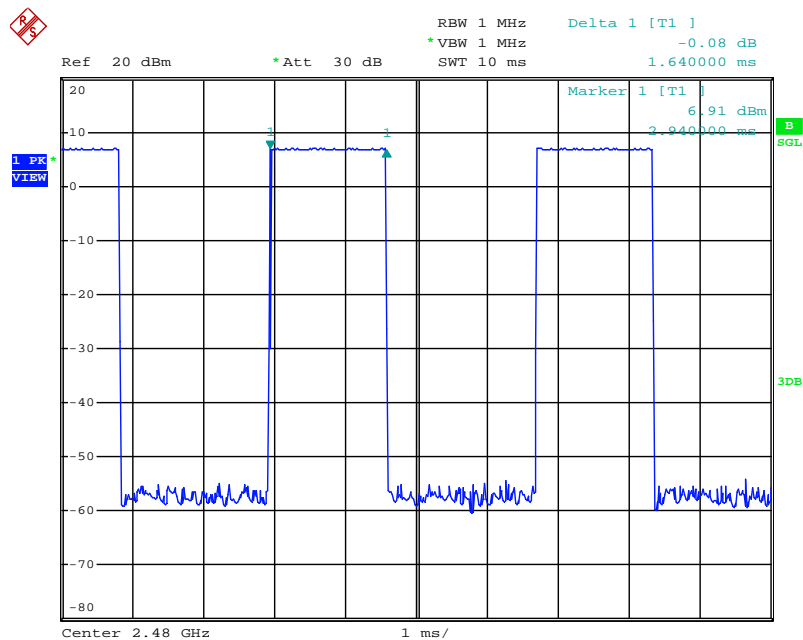

Date: 7.DEC.2011 10:32:23

Dwell Time Plot on Channel 78 / 3DH1 / 2480 MHz

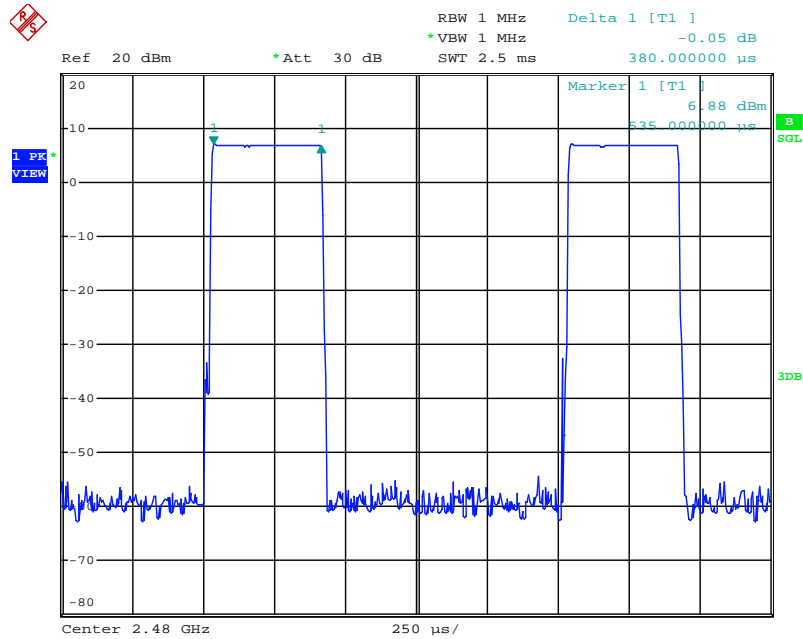

Date: 7.DEC.2011 10:37:03

Dwell Time Plot on Channel 0 / DH1 / 2402 MHz

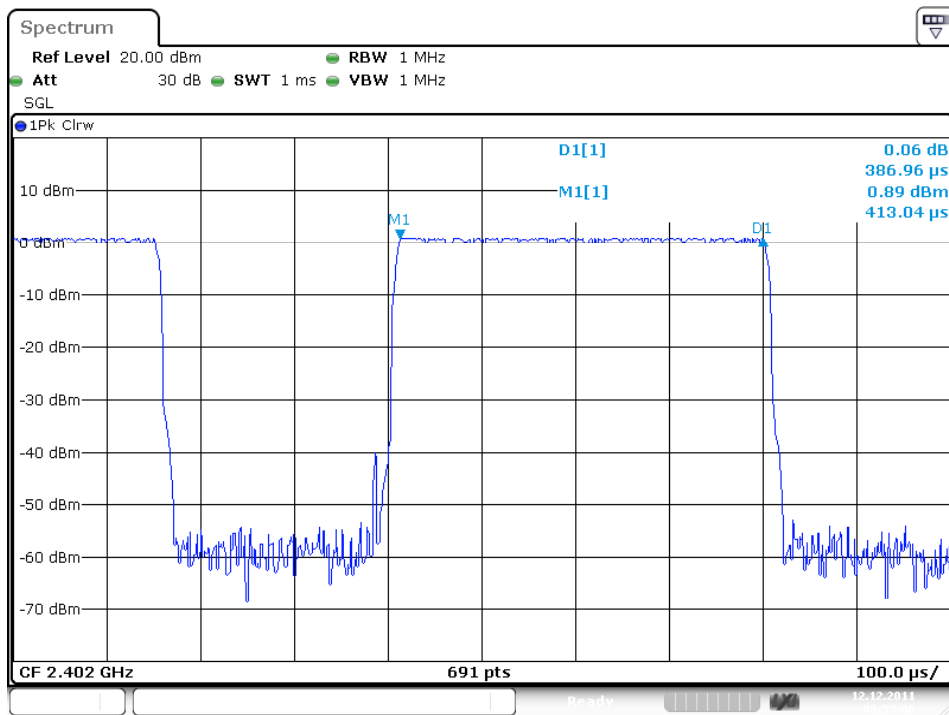

Date: 12.DEC.2011 09:53:06

Dwell Time Plot on Channel 19 / DH1 / 2440 MHz

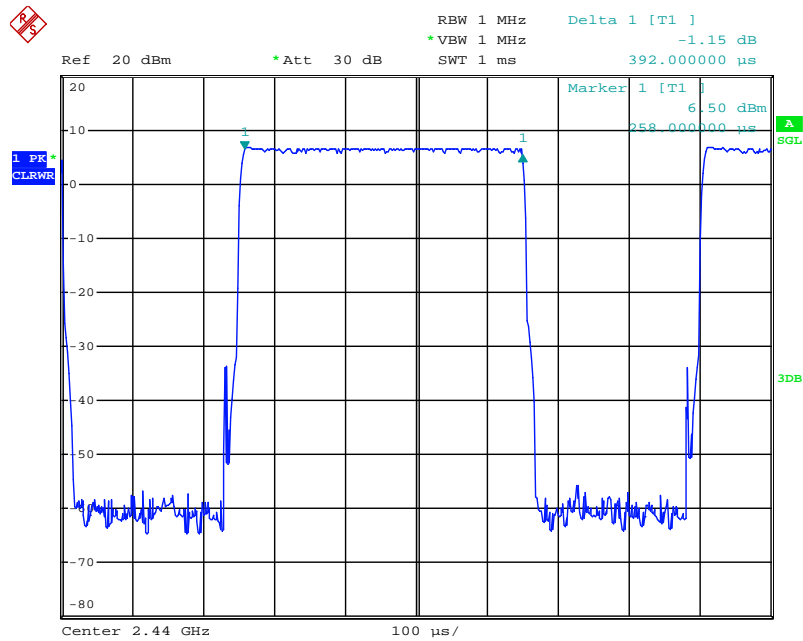

Date: 27.DEC.2011 15:33:42

Dwell Time Plot on Channel 39 / DH1 / 2480 MHz

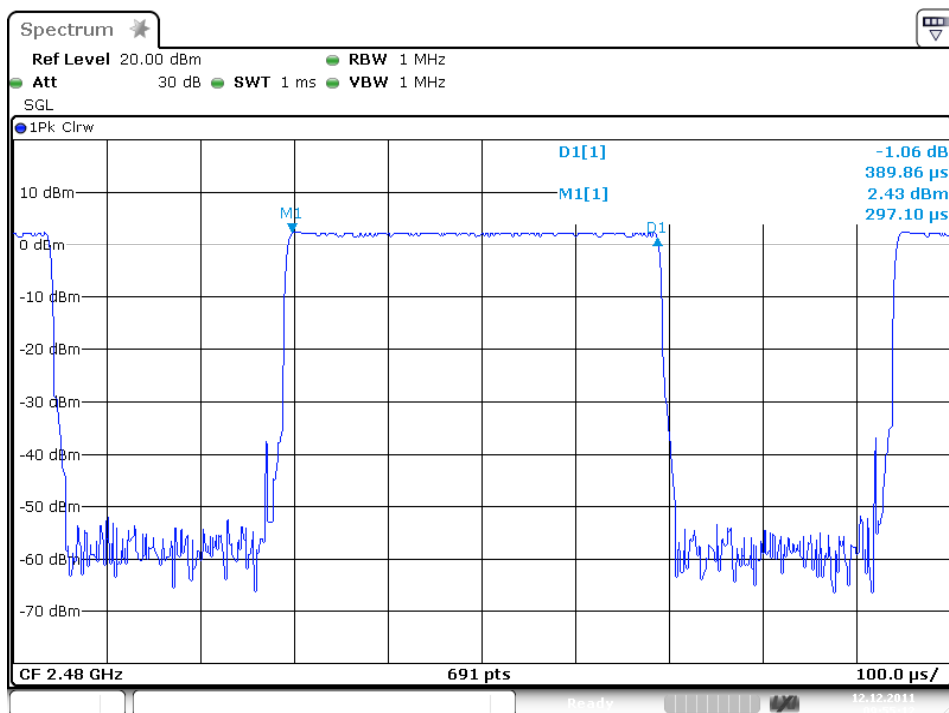

Date: 12.DEC.2011 09:55:12

4.7. Radiated Emissions Measurement

4.7.1. Limit

20dBc in any 100 kHz bandwidth outside the operating frequency band. In case the emission fall within the restricted band specified on 15.205(a), then the 15.209(a) limit in the table below has to be followed.

Frequencies (MHz)	Field Strength (micorvolts/meter)	Measurement Distance (meters)
0.009~0.490	2400/F(KHz)	300
0.490~1.705	24000/F(KHz)	30
1.705~30.0	30	30
30~88	100	3
88~216	150	3
216~960	200	3
Above 960	500	3

4.7.2. Measuring Instruments and Setting

Please refer to section 5 of equipments list in this report. The following table is the setting of spectrum analyzer and receiver.

Spectrum Parameter	Setting
Attenuation	Auto
Start Frequency	1000 MHz
Stop Frequency	10th carrier harmonic
RB / VB (Emission in restricted band)	1MHz / 3MHz for Peak, 1 MHz / 10Hz for Average
RB / VB (Emission in non-restricted band)	1MHz / 3MHz for peak

Receiver Parameter	Setting
Attenuation	Auto
Start ~ Stop Frequency	9kHz~150kHz / RB 200Hz for QP
Start ~ Stop Frequency	150kHz~30MHz / RB 9kHz for QP
Start ~ Stop Frequency	30MHz~1000MHz / RB 120kHz for QP

4.7.3. Test Procedures

1. Configure the EUT according to ANSI C63.10. The EUT was placed on the top of the turntable 0.8 meter above ground. The phase center of the receiving antenna mounted on the top of a height-variable antenna tower was placed 3 meters far away from the turntable.
2. Power on the EUT and all the supporting units. The turntable was rotated by 360 degrees to determine the position of the highest radiation.
3. The height of the broadband receiving antenna was varied between one meter and four meters above ground to find the maximum emissions field strength of both horizontal and vertical polarization.
4. For each suspected emissions, the antenna tower was scan (from 1 M to 4 M) and then the turntable was rotated (from 0 degree to 360 degrees) to find the maximum reading.
5. Set the test-receiver system to Peak or CISPR quasi-peak Detect Function with specified bandwidth under Maximum Hold Mode.
6. For emissions above 1GHz, use 1MHz VBW and RBW for peak reading. Then 1MHz RBW and 10Hz VBW for average reading in spectrum analyzer.
7. When the radiated emissions limits are expressed in terms of the average value of the emissions, and pulsed operation is employed, the measurement field strength shall be determined by averaging over one complete pulse train, including blanking intervals, as long as the pulse train does not exceed 0.1 seconds. As an alternative (provided the transmitter operates for longer than 0.1 seconds) or in cases where the pulse train exceeds 0.1 seconds, the measured field strength shall be determined from the average absolute voltage during a 0.1 second interval during which the field strength is at its maximum value.
8. If the emissions level of the EUT in peak mode was 3 dB lower than the average limit specified, then testing will be stopped and peak values of EUT will be reported, otherwise, the emissions which do not have 3 dB margin will be repeated one by one using the quasi-peak method for below 1GHz.
9. For testing above 1GHz, the emissions level of the EUT in peak mode was lower than average limit (that means the emissions level in peak mode also complies with the limit in average mode), then testing will be stopped and peak values of EUT will be reported, otherwise, the emissions will be measured in average mode again and reported.
10. In case the emission is lower than 30MHz, loop antenna has to be used for measurement and the recorded data should be QP measured by receiver. High – Low scan is not required in this case.

4.7.4. Test Setup Layout

For radiated emissions below 1GHz

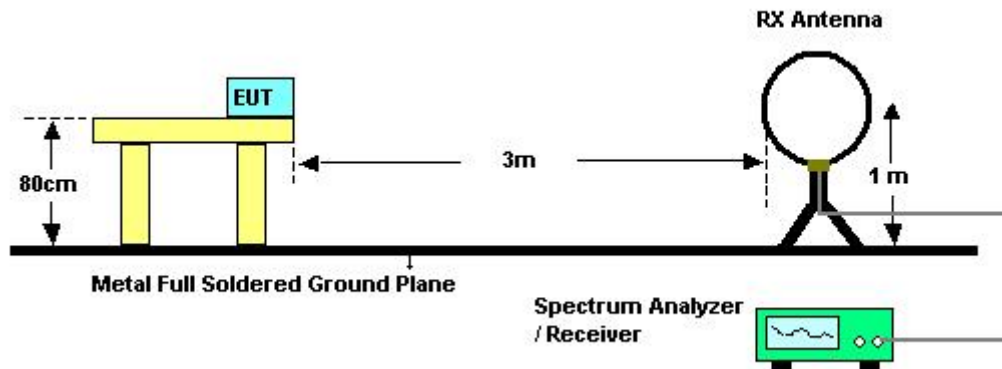

For radiated emissions above 1GHz

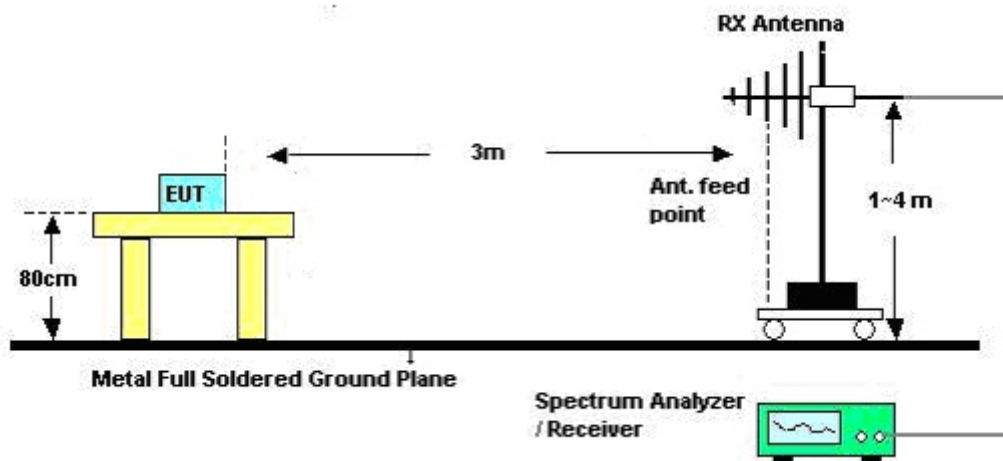

4.7.5. Test Deviation

There is no deviation with the original standard.

4.7.6. EUT Operation during Test

The EUT was programmed to be in continuously transmitting mode.

4.7.7. Results of Radiated Emissions (9kHz~30MHz)

Temperature	23°C	Humidity	65%
Test Engineer	Rion Li	Test Date	Dec. 15, 2011

Freq. (MHz)	Level (dBuV)	Over Limit (dB)	Limit Line (dBuV)	Remark
-	-	-	-	See Note

Note:

The amplitude of spurious emissions which are attenuated by more than 20dB below the permissible value has no need to be reported.

Distance extrapolation factor = $40 \log(\text{specific distance} / \text{test distance})$ (dB);

Limit line = specific limits (dBuV) + distance extrapolation factor.

4.7.8. Results of Radiated Emissions (30MHz~1GHz)

Test Mode : Mode 1

Temperature	23°C	Humidity	65%
Test Engineer	Rion Li	Configurations	Normal Link

Horizontal

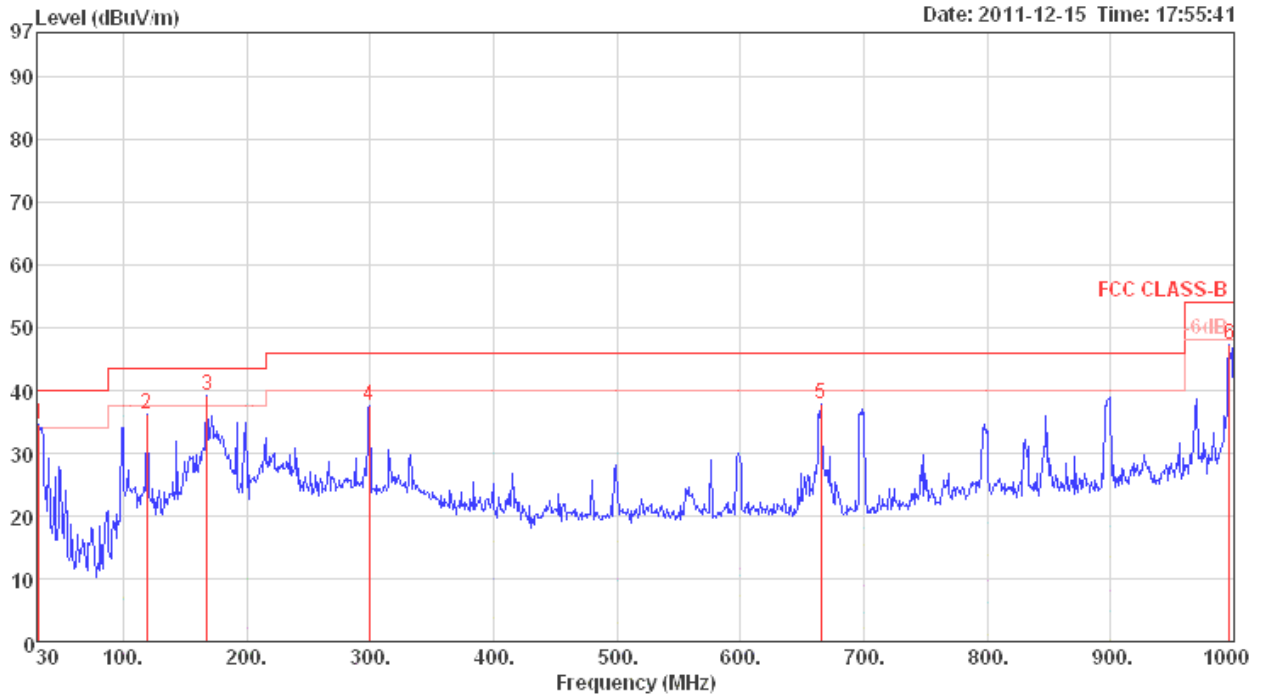

	Freq	Level	Limit	Over	Read	CableAntenna	Preamp	A/Pos	T/Pos	Remark	PoI/Phase
	MHz	dBuV/m	dBuV/m	dB	dBuV	dB	dB/m	dB	cm	deg	
1	31.94	34.46	40.00	-5.54	44.07	0.50	17.69	27.80	400	0 Peak	HORIZONTAL
2	119.24	36.09	43.50	-7.41	49.93	1.20	12.46	27.50	400	0 Peak	HORIZONTAL
3	167.74	39.11	43.50	-4.39	52.22	1.54	12.61	27.26	400	0 Peak	HORIZONTAL
4	299.66	37.48	46.00	-8.52	48.92	2.10	13.36	26.90	400	0 Peak	HORIZONTAL
5	665.35	37.79	46.00	-8.21	43.40	3.44	18.98	28.03	400	0 Peak	HORIZONTAL
6	996.12	47.25	54.00	-6.75	49.32	3.69	21.26	27.02	400	0 Peak	HORIZONTAL

Vertical

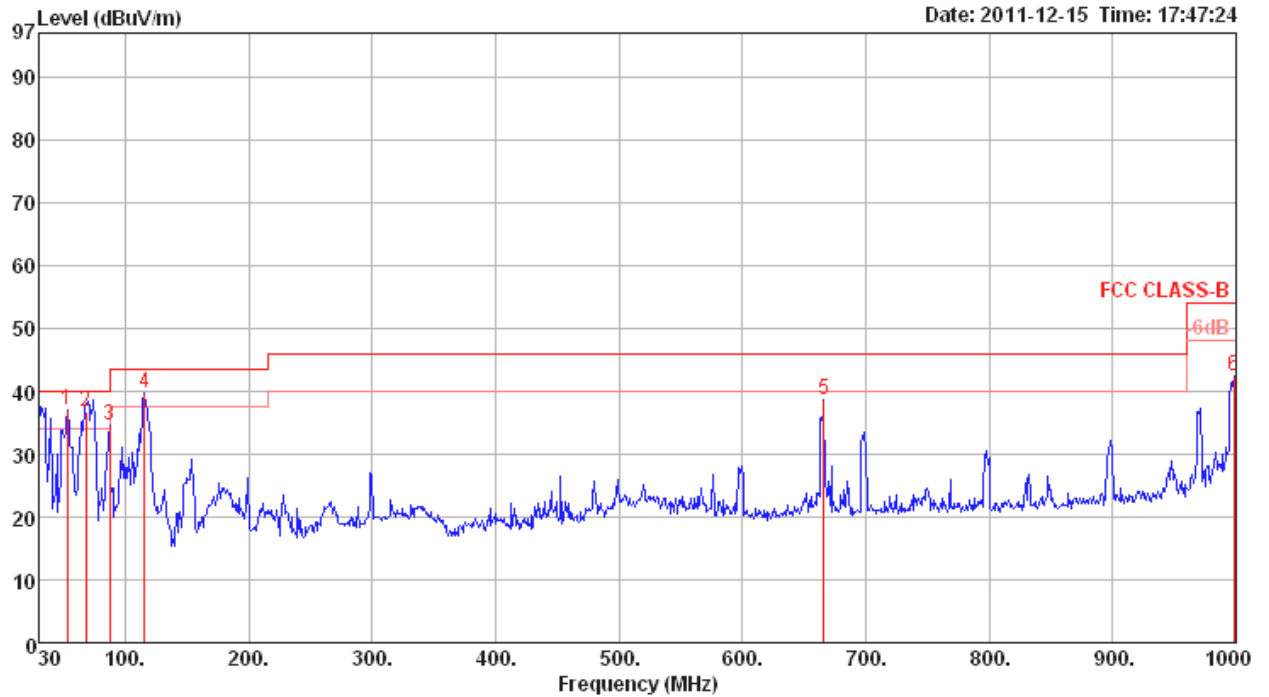

	Freq	Level	Limit	Over	Read	CableAntenna	Preamp	A/Pos	T/Pos	Remark	Pol/Phase
	MHz	dBuV/m	dBuV/m	dB	dBuV	dB	dB/m	dB	cm	deg	
1	53.28	36.90	40.00	-3.10	55.93	0.76	8.00	27.79	400	0 Peak	VERTICAL
2	68.00	36.88	40.00	-3.12	57.10	0.84	6.67	27.73	100	251 QP	VERTICAL
3	87.23	34.70	40.00	-5.30	52.81	1.10	8.44	27.65	400	0 Peak	VERTICAL
4	115.36	39.59	43.50	-3.91	53.75	1.20	12.16	27.52	400	0 Peak	VERTICAL
5	666.32	38.53	46.00	-7.47	44.15	3.43	18.98	28.03	400	0 Peak	VERTICAL
6	998.06	42.35	54.00	-11.65	44.38	3.70	21.28	27.01	400	0 Peak	VERTICAL

Note:

The amplitude of spurious emissions that are attenuated by more than 20dB below the permissible value has no need to be reported.

Emission level (dBuV/m) = 20 log Emission level (uV/m).

Corrected Reading: Antenna Factor + Cable Loss + Read Level - Preamp Factor = Level.

Test Mode : Mode 2

Temperature	23°C	Humidity	65%
Test Engineer	Rion Li	Configurations	Normal Link

Horizontal

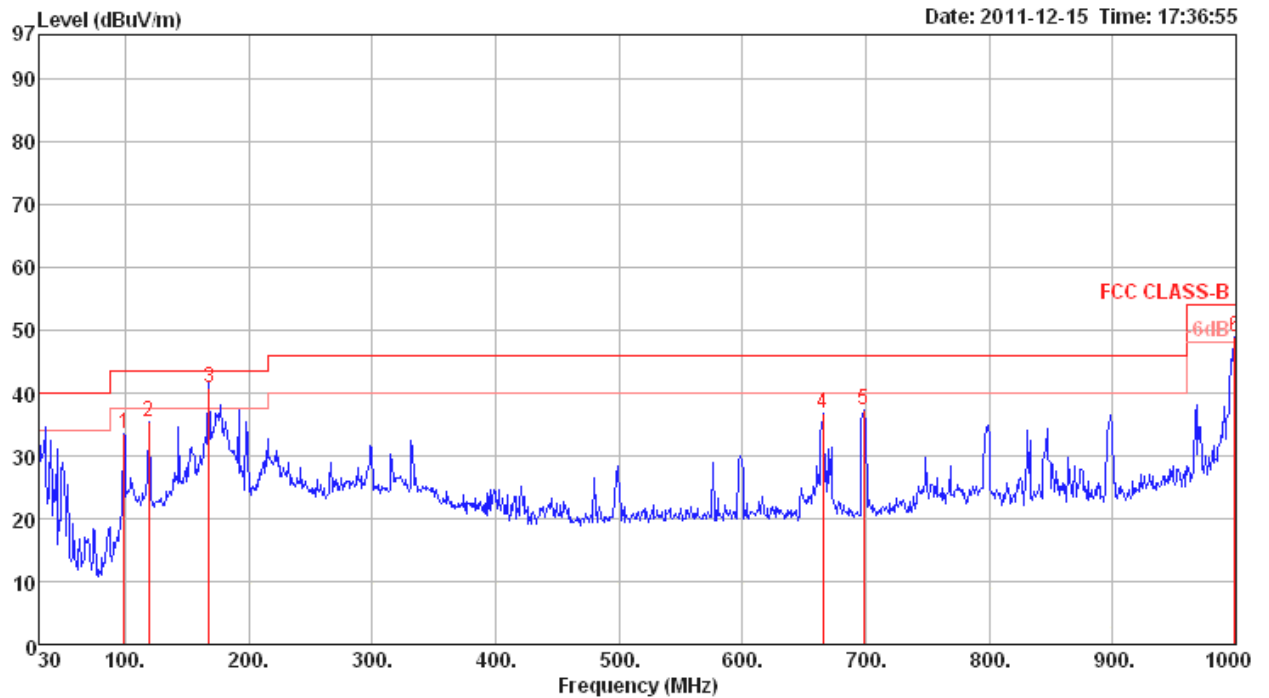

	Freq	Level	Limit Line	Over Limit	Read Level	CableAntenna Loss	Preamp Factor	A/Pos	T/Pos	Remark	PoI/Phase
	MHz	dBuV/m	dBuV/m	dB	dBuV	dB	dB/m	dB	cm	deg	
1	98.87	33.38	43.50	-10.12	49.02	1.18	10.79	27.61	400	0 Peak	HORIZONTAL
2	119.24	35.33	43.50	-8.17	49.17	1.20	12.46	27.50	400	0 Peak	HORIZONTAL
3	168.00	40.89	43.50	-2.61	54.00	1.54	12.61	27.26	132	145 QP	HORIZONTAL
4	665.35	36.81	46.00	-9.19	42.42	3.44	18.98	28.03	400	0 Peak	HORIZONTAL
5	698.33	37.31	46.00	-8.69	42.92	3.31	19.08	28.00	400	0 Peak	HORIZONTAL
6	999.03	48.88	54.00	-5.12	50.91	3.70	21.28	27.01	400	0 Peak	HORIZONTAL

Vertical

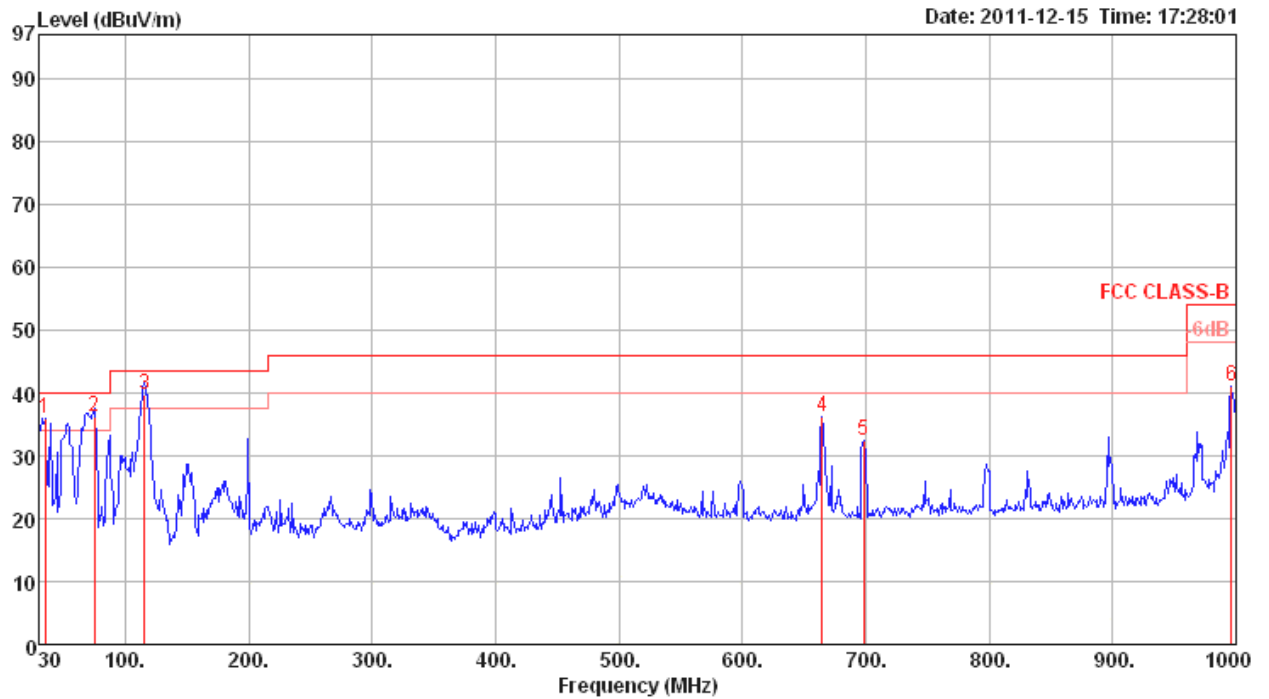

	Freq	Level	Limit Line	Over Limit	Read Level	CableAntenna Loss	Preamp Factor	A/Pos	T/Pos	Remark	Pol/Phase
	MHz	dBuV/m	dBuV/m	dB	dBuV	dB	dB/m	dB	cm	deg	
1	34.85	35.98	40.00	-4.02	47.20	0.50	16.08	27.80	400	0 Peak	VERTICAL
2	75.00	36.08	40.00	-3.92	56.00	0.90	6.88	27.70	100	58 QP	VERTICAL
3	115.36	39.84	43.50	-3.66	54.00	1.20	12.16	27.52	106	187 QP	VERTICAL
4	664.38	36.30	46.00	-9.70	41.92	3.44	18.98	28.04	400	0 Peak	VERTICAL
5	698.33	32.29	46.00	-13.71	37.90	3.31	19.08	28.00	400	0 Peak	VERTICAL
6	996.12	41.20	54.00	-12.80	43.27	3.69	21.26	27.02	400	0 Peak	VERTICAL

Note:

The amplitude of spurious emissions that are attenuated by more than 20dB below the permissible value has no need to be reported.

Emission level (dBuV/m) = 20 log Emission level (uV/m).

Corrected Reading: Antenna Factor + Cable Loss + Read Level - Preamp Factor = Level.

4.7.9. Results for Radiated Emissions (1GHz~10th Harmonic)

For Bluetooth 2.1 + EDR :

Temperature	23°C	Humidity	65%
Test Engineer	Rion Li	Configurations	Channel 0 / Chain 2
Test Date	Dec. 08, 2011	Test Mode	Mode 1

Horizontal

	Freq	Level	Limit Line	Over Limit	Read Level	Cable Loss	Preamp Factor	Antenna Factor	T/Pos	A/Pos	Remark	Pol/Phase
	MHz	dBuV/m	dBuV/m	dB	dBuV	dB	dB	dB/m	deg	cm		
1 a	4803.94	31.02	54.00	-22.98	29.84	4.08	35.32	32.42	202	100	Average	HORIZONTAL
2 p	4804.26	44.09	74.00	-29.91	42.91	4.08	35.32	32.42	202	100	Peak	HORIZONTAL

Vertical

	Freq	Level	Limit Line	Over Limit	Read Level	Cable Loss	Preamp Factor	Antenna Factor	T/Pos	A/Pos	Remark	Pol/Phase
	MHz	dBuV/m	dBuV/m	dB	dBuV	dB	dB	dB/m	deg	cm		
1 p	4803.89	49.70	74.00	-24.30	48.52	4.08	35.32	32.42	96	115	Peak	VERTICAL
2 a	4803.99	37.92	54.00	-16.08	36.74	4.08	35.32	32.42	96	115	Average	VERTICAL

Temperature	23°C	Humidity	65%
Test Engineer	Rion Li	Configurations	Channel 39 / Chain 2
Test Date	Dec. 08, 2011	Chain	Mode 1

Horizontal

	Freq	Level	Limit Line	Over Limit	Read Level	Cable Loss	Preamp Factor	Antenna Factor	T/Pos	A/Pos	Remark	Pol/Phase
	MHz	dBuV/m	dBuV/m	dB	dBuV	dB	dB	dB/m	deg	cm		
1	4881.54	44.54	74.00	-29.46	43.02	4.11	35.15	32.56	294	103	Peak	HORIZONTAL
2	4881.98	31.69	54.00	-22.31	30.17	4.11	35.15	32.56	294	103	Average	HORIZONTAL
3 a	7322.99	34.60	54.00	-19.40	27.53	5.31	34.93	36.69	143	100	Average	HORIZONTAL
4 p	7323.41	48.64	74.00	-25.36	41.57	5.31	34.93	36.69	143	100	Peak	HORIZONTAL

Vertical

	Freq	Level	Limit Line	Over Limit	Read Level	Cable Loss	Preamp Factor	Antenna Factor	T/Pos	A/Pos	Remark	Pol/Phase
	MHz	dBuV/m	dBuV/m	dB	dBuV	dB	dB	dB/m	deg	cm		
1	4881.97	37.34	54.00	-16.66	35.82	4.11	35.15	32.56	95	100	Average	VERTICAL
2	4882.37	48.97	74.00	-25.03	47.45	4.11	35.15	32.56	95	100	Peak	VERTICAL
3 p	7322.97	51.79	74.00	-22.21	44.72	5.31	34.93	36.69	89	151	Peak	VERTICAL
4 a	7322.98	38.34	54.00	-15.66	31.27	5.31	34.93	36.69	89	151	Average	VERTICAL

Temperature	23°C	Humidity	65%
Test Engineer	Rion Li	Configurations	Channel 78 / Chain 2
Test Date	Dec. 08, 2011	Chain	Mode 1

Horizontal

	Freq	Level	Limit Line	Over Limit	Read Level	Cable Loss	Preamp Factor	Antenna Factor	T/Pos	A/Pos	Remark	Pol/Phase
	MHz	dBuV/m	dBuV/m	dB	dBuV	dB	dB	dB/m	deg	cm		
1	4959.89	32.40	54.00	-21.60	30.50	4.14	34.97	32.73	293	102	Average	HORIZONTAL
2	4960.21	45.26	74.00	-28.74	43.36	4.14	34.97	32.73	293	102	Peak	HORIZONTAL
3 a	7435.34	35.05	54.00	-18.95	27.70	5.39	34.88	36.84	191	100	Average	HORIZONTAL
4 p	7440.06	48.77	74.00	-25.23	41.41	5.39	34.87	36.84	191	100	Peak	HORIZONTAL

Vertical

	Freq	Level	Limit Line	Over Limit	Read Level	Cable Loss	Preamp Factor	Antenna Factor	T/Pos	A/Pos	Remark	Pol/Phase
	MHz	dBuV/m	dBuV/m	dB	dBuV	dB	dB	dB/m	deg	cm		
1	4959.93	36.10	54.00	-17.90	34.20	4.14	34.97	32.73	94	100	Average	VERTICAL
2	4960.21	48.63	74.00	-25.37	46.73	4.14	34.97	32.73	94	100	Peak	VERTICAL
3 a	7439.86	39.42	54.00	-14.58	32.06	5.39	34.87	36.84	83	150	Average	VERTICAL
4 p	7439.90	52.80	74.00	-21.20	45.44	5.39	34.87	36.84	83	150	Peak	VERTICAL

Note:

The amplitude of spurious emissions which are attenuated by more than 20dB below the permissible value has no need to be reported.

Emission level (dBuV/m) = 20 log Emission level (uV/m).

Corrected Reading: Antenna Factor + Cable Loss + Read Level - Preamp Factor = Level.

For Bluetooth 2.1 + EDR :

Temperature	23°C	Humidity	65%
Test Engineer	Rion Li	Configurations	Channel 0 / Chain 2
Test Date	Dec. 08, 2011	Test Mode	Mode 2

Horizontal

	Freq	Level	Limit Line	Over Limit	Read Level	Cable Loss	Preamp Factor	Antenna Factor	T/Pos	A/Pos	Remark	Pol/Phase
	MHz	dBuV/m	dBuV/m	dB	dBuV	dB	dB	dB/m	deg	cm		
1 a	4803.94	40.93	54.00	-13.07	39.75	4.08	35.32	32.42	281	101	Average	HORIZONTAL
2 p	4804.11	46.77	74.00	-27.23	45.59	4.08	35.32	32.42	281	101	Peak	HORIZONTAL

Vertical

	Freq	Level	Limit Line	Over Limit	Read Level	Cable Loss	Preamp Factor	Antenna Factor	T/Pos	A/Pos	Remark	Pol/Phase
	MHz	dBuV/m	dBuV/m	dB	dBuV	dB	dB	dB/m	deg	cm		
1 a	4803.94	50.59	54.00	-3.41	49.41	4.08	35.32	32.42	170	100	Average	VERTICAL
2 p	4803.96	53.23	74.00	-20.77	52.05	4.08	35.32	32.42	170	100	Peak	VERTICAL

Temperature	23°C	Humidity	65%
Test Engineer	Rion Li	Configurations	Channel 39 / Chain 2
Test Date	Dec. 08, 2011	Chain	Mode 2

Horizontal

	Freq	Level	Limit Line	Over Limit	Read Level	Cable Loss	Preamp Factor	Antenna Factor	T/Pos	A/Pos	Remark	Pol/Phase
	MHz	dBuV/m	dBuV/m	dB	dBuV	dB	dB	dB/m	deg	cm		
1	4881.93	46.89	74.00	-27.11	45.37	4.11	35.15	32.56	310	100	Peak	HORIZONTAL
2	4881.93	40.26	54.00	-13.74	38.74	4.11	35.15	32.56	310	100	Average	HORIZONTAL
3 p	7322.88	52.26	74.00	-21.74	45.19	5.31	34.93	36.69	145	175	Peak	HORIZONTAL
4 a	7322.94	45.71	54.00	-8.29	38.64	5.31	34.93	36.69	145	175	Average	HORIZONTAL

Vertical

	Freq	Level	Limit Line	Over Limit	Read Level	Cable Loss	Preamp Factor	Antenna Factor	T/Pos	A/Pos	Remark	Pol/Phase
	MHz	dBuV/m	dBuV/m	dB	dBuV	dB	dB	dB/m	deg	cm		
1 a	4881.94	50.55	54.00	-3.45	49.03	4.11	35.15	32.56	163	110	Average	VERTICAL
2	4881.98	53.12	74.00	-20.88	51.60	4.11	35.15	32.56	163	110	Peak	VERTICAL
3 p	7322.91	53.30	74.00	-20.70	46.23	5.31	34.93	36.69	92	201	Peak	VERTICAL
4	7322.97	47.87	54.00	-6.13	40.80	5.31	34.93	36.69	92	201	Average	VERTICAL

Temperature	23°C	Humidity	65%
Test Engineer	Rion Li	Configurations	Channel 78 / Chain 2
Test Date	Dec. 08, 2011	Chain	Mode 2

Horizontal

	Freq	Level	Limit Line	Over Limit	Read Level	Cable Loss	Antenna Factor	Preamp Factor	Remark	A/Pos	T/Pos	Pol/Phase
	MHz	dBuV/m	dBuV/m	dB	dBuV	dB	dB/m	dB		cm	deg	
1	4959.96	48.49	74.00	-25.51	46.80	3.37	33.33	35.01	Peak	100	41	HORIZONTAL
2	4960.03	43.28	54.00	-10.72	41.59	3.37	33.33	35.01	Average	100	41	HORIZONTAL
3	7440.00	49.81	74.00	-24.19	44.94	4.07	36.20	35.40	Peak	101	17	HORIZONTAL
4	7440.03	42.42	54.00	-11.58	37.55	4.07	36.20	35.40	Average	101	17	HORIZONTAL

Vertical

	Freq	Level	Limit Line	Over Limit	Read Level	Cable Loss	Antenna Factor	Preamp Factor	Remark	A/Pos	T/Pos	Pol/Phase
	MHz	dBuV/m	dBuV/m	dB	dBuV	dB	dB/m	dB		cm	deg	
1	4960.02	47.87	54.00	-6.13	46.18	3.37	33.33	35.01	Average	100	161	VERTICAL
2	4960.04	51.25	74.00	-22.75	49.56	3.37	33.33	35.01	Peak	100	161	VERTICAL
3	7440.01	55.66	74.00	-18.34	50.79	4.07	36.20	35.40	Peak	147	262	VERTICAL
4	7440.04	52.69	54.00	-1.31	47.82	4.07	36.20	35.40	Average	147	262	VERTICAL

Note:

The amplitude of spurious emissions which are attenuated by more than 20dB below the permissible value has no need to be reported.

Emission level (dBuV/m) = 20 log Emission level (uV/m).

Corrected Reading: Antenna Factor + Cable Loss + Read Level - Preamp Factor = Level.

For Bluetooth 4.0 :

Temperature	23°C	Humidity	65%
Test Engineer	Rion Li	Configurations	Channel 0 / Chain 2
Test Date	Dec. 08, 2011	Test Mode	Mode 1

Horizontal

	Freq	Level	Limit	Over	Read	Cable	Preamp	Antenna	T/Pos	A/Pos	Remark	Pol/Phase
	MHz	dBuV/m	dBuV/m	dB	dBuV	dB	dB	dB/m	deg	cm		
1 p	4803.71	46.01	74.00	-27.99	44.83	4.08	35.32	32.42	287	149	Peak	HORIZONTAL
2 a	4803.89	33.32	54.00	-20.68	32.14	4.08	35.32	32.42	287	149	Average	HORIZONTAL

Vertical

	Freq	Level	Limit	Over	Read	Cable	Preamp	Antenna	T/Pos	A/Pos	Remark	Pol/Phase
	MHz	dBuV/m	dBuV/m	dB	dBuV	dB	dB	dB/m	deg	cm		
1 a	4803.97	39.67	54.00	-14.33	38.49	4.08	35.32	32.42	95	119	Average	VERTICAL
2 p	4803.98	53.17	74.00	-20.83	51.99	4.08	35.32	32.42	95	119	Peak	VERTICAL

Temperature	23°C	Humidity	65%
Test Engineer	Rion Li	Configurations	Channel 19 / Chain 2
Test Date	Dec. 08, 2011	Chain	Mode 1

Horizontal

	Freq	Level	Limit Line	Over Limit	Read Level	Cable Loss	Preamp Factor	Antenna Factor	T/Pos	A/Pos	Remark	Pol/Phase
	MHz	dBuV/m	dBuV/m	dB	dBuV	dB	dB	dB/m	deg	cm		
1	4879.45	44.75	74.00	-29.25	43.23	4.11	35.15	32.56	208	100	Peak	HORIZONTAL
2	4879.95	31.87	54.00	-22.13	30.35	4.11	35.15	32.56	208	100	Average	HORIZONTAL
3 a	7319.33	38.42	54.00	-15.58	31.35	5.31	34.93	36.69	51	186	Average	HORIZONTAL
4 p	7319.88	52.41	74.00	-21.59	45.34	5.31	34.93	36.69	51	186	Peak	HORIZONTAL

Vertical

	Freq	Level	Limit Line	Over Limit	Read Level	Cable Loss	Preamp Factor	Antenna Factor	T/Pos	A/Pos	Remark	Pol/Phase
	MHz	dBuV/m	dBuV/m	dB	dBuV	dB	dB	dB/m	deg	cm		
1	4879.40	51.37	74.00	-22.63	49.85	4.11	35.15	32.56	85	115	Peak	VERTICAL
2	4879.95	38.11	54.00	-15.89	36.59	4.11	35.15	32.56	85	115	Average	VERTICAL
3 p	7319.04	54.19	74.00	-19.81	47.12	5.31	34.93	36.69	83	148	Peak	VERTICAL
4 a	7319.41	39.27	54.00	-14.73	32.20	5.31	34.93	36.69	83	148	Average	VERTICAL

Temperature	23°C	Humidity	65%
Test Engineer	Rion Li	Configurations	Channel 39 / Chain 2
Test Date	Dec. 08, 2011	Chain	Mode 1

Horizontal

	Freq	Level	Limit Line	Over Limit	Read Level	Cable Loss	Preamp Factor	Antenna Factor	T/Pos	A/Pos	Remark	Pol/Phase
	MHz	dBuV/m	dBuV/m	dB	dBuV	dB	dB	dB/m	deg	cm		
1	4959.62	44.94	74.00	-29.06	43.04	4.14	34.97	32.73	57	100	Peak	HORIZONTAL
2	4959.87	32.22	54.00	-21.78	30.32	4.14	34.97	32.73	57	100	Average	HORIZONTAL
3 p	7439.34	52.92	74.00	-21.08	45.56	5.39	34.87	36.84	140	167	Peak	HORIZONTAL
4 a	7439.41	38.67	54.00	-15.33	31.31	5.39	34.87	36.84	140	167	Average	HORIZONTAL

Vertical

	Freq	Level	Limit Line	Over Limit	Read Level	Cable Loss	Preamp Factor	Antenna Factor	T/Pos	A/Pos	Remark	Pol/Phase
	MHz	dBuV/m	dBuV/m	dB	dBuV	dB	dB	dB/m	deg	cm		
1	4959.40	48.50	74.00	-25.50	46.60	4.14	34.97	32.73	85	100	Peak	VERTICAL
2	4959.94	35.78	54.00	-18.22	33.88	4.14	34.97	32.73	85	100	Average	VERTICAL
3 p	7439.16	55.97	74.00	-18.03	48.61	5.39	34.87	36.84	97	150	Peak	VERTICAL
4 a	7439.35	41.04	54.00	-12.96	33.68	5.39	34.87	36.84	97	150	Average	VERTICAL

Note:

The amplitude of spurious emissions which are attenuated by more than 20dB below the permissible value has no need to be reported.

Emission level (dBuV/m) = 20 log Emission level (uV/m).

Corrected Reading: Antenna Factor + Cable Loss + Read Level - Preamp Factor = Level.

For Bluetooth 4.0 :

Temperature	23°C	Humidity	65%
Test Engineer	Rion Li	Configurations	Channel 0 / Chain 2
Test Date	Dec. 08, 2011	Test Mode	Mode 2

Horizontal

	Freq	Level	Limit Line	Over Limit	Read Level	Cable Loss	Preamp Factor	Antenna Factor	T/Pos	A/Pos	Remark	Pol/Phase
	MHz	dBuV/m	dBuV/m	dB	dBuV	dB	dB	dB/m	deg	cm		
1 p	4803.53	46.99	74.00	-27.01	45.81	4.08	35.32	32.42	157	100	Peak	HORIZONTAL
2 a	4803.92	33.20	54.00	-20.80	32.02	4.08	35.32	32.42	157	100	Average	HORIZONTAL

Vertical

	Freq	Level	Limit Line	Over Limit	Read Level	Cable Loss	Preamp Factor	Antenna Factor	T/Pos	A/Pos	Remark	Pol/Phase
	MHz	dBuV/m	dBuV/m	dB	dBuV	dB	dB	dB/m	deg	cm		
1 a	4803.94	38.93	54.00	-15.07	37.75	4.08	35.32	32.42	94	100	Average	VERTICAL
2 p	4804.44	52.11	74.00	-21.89	50.93	4.08	35.32	32.42	94	100	Peak	VERTICAL

Temperature	23°C	Humidity	65%
Test Engineer	Rion Li	Configurations	Channel 19 / Chain 2
Test Date	Dec. 08, 2011	Chain	Mode 2

Horizontal

	Freq	Level	Limit Line	Over Limit	Read Level	Cable Loss	Preamp Factor	Antenna Factor	T/Pos	A/Pos	Remark	Pol/Phase
	MHz	dBuV/m	dBuV/m	dB	dBuV	dB	dB	dB/m	deg	cm		
1	4879.49	47.25	74.00	-26.75	45.73	4.11	35.15	32.56	37	120	Peak	HORIZONTAL
2	4879.96	34.57	54.00	-19.43	33.05	4.11	35.15	32.56	37	120	Average	HORIZONTAL
3 p	7319.27	51.99	74.00	-22.01	44.92	5.31	34.93	36.69	31	183	Peak	HORIZONTAL
4 a	7319.36	38.16	54.00	-15.84	31.09	5.31	34.93	36.69	31	183	Average	HORIZONTAL

Vertical

	Freq	Level	Limit Line	Over Limit	Read Level	Cable Loss	Preamp Factor	Antenna Factor	T/Pos	A/Pos	Remark	Pol/Phase
	MHz	dBuV/m	dBuV/m	dB	dBuV	dB	dB	dB/m	deg	cm		
1	4879.47	51.22	74.00	-22.78	49.70	4.11	35.15	32.56	86	127	Peak	VERTICAL
2 a	4879.98	38.19	54.00	-15.81	36.67	4.11	35.15	32.56	86	127	Average	VERTICAL
3	7319.44	38.12	54.00	-15.88	31.05	5.31	34.93	36.69	26	134	Average	VERTICAL
4 p	7320.84	52.23	74.00	-21.77	45.16	5.31	34.93	36.69	26	134	Peak	VERTICAL

Temperature	23°C	Humidity	65%
Test Engineer	Rion Li	Configurations	Channel 39 / Chain 2
Test Date	Dec. 08, 2011	Chain	Mode 2

Horizontal

	Freq	Level	Limit Line	Over Limit	Read Level	Cable Loss	Preamp Factor	Antenna Factor	T/Pos	A/Pos	Remark	Pol/Phase
	MHz	dBuV/m	dBuV/m	dB	dBuV	dB	dB	dB/m	deg	cm		
1	4959.37	47.52	74.00	-26.48	45.62	4.14	34.97	32.73	140	100	Peak	HORIZONTAL
2	4959.94	34.55	54.00	-19.45	32.65	4.14	34.97	32.73	140	100	Average	HORIZONTAL
3 p	7439.19	55.97	74.00	-18.03	48.61	5.39	34.87	36.84	30	194	Peak	HORIZONTAL
4 a	7439.40	41.25	54.00	-12.75	33.89	5.39	34.87	36.84	30	194	Average	HORIZONTAL

Vertical

	Freq	Level	Limit Line	Over Limit	Read Level	Cable Loss	Preamp Factor	Antenna Factor	T/Pos	A/Pos	Remark	Pol/Phase
	MHz	dBuV/m	dBuV/m	dB	dBuV	dB	dB	dB/m	deg	cm		
1	4959.95	51.15	74.00	-22.85	49.25	4.14	34.97	32.73	158	104	Peak	VERTICAL
2	4959.96	38.11	54.00	-15.89	36.21	4.14	34.97	32.73	158	104	Average	VERTICAL
3 a	7439.40	41.17	54.00	-12.83	33.81	5.39	34.87	36.84	22	177	Average	VERTICAL
4 p	7440.71	56.02	74.00	-17.98	48.66	5.39	34.87	36.84	22	177	Peak	VERTICAL

Note:

The amplitude of spurious emissions which are attenuated by more than 20dB below the permissible value has no need to be reported.

Emission level (dBuV/m) = 20 log Emission level (uV/m).

Corrected Reading: Antenna Factor + Cable Loss + Read Level - Preamp Factor = Level.

4.8. Band Edge Emissions Measurement

4.8.1. Limit

20dBc in any 100 kHz bandwidth outside the operating frequency band. In case the emission fall within the restricted band specified on 15.205(a), then the 15.209(a) limit in the table below has to be followed.

Frequencies (MHz)	Field Strength (micorvolts/meter)	Measurement Distance (meters)
0.009~0.490	2400/F(KHz)	300
0.490~1.705	24000/F(KHz)	30
1.705~30.0	30	30
30~88	100	3
88~216	150	3
216~960	200	3
Above 960	500	3

4.8.2. Measuring Instruments and Setting

Please refer to section 5 of equipments list in this report. The following table is the setting of the spectrum analyzer.

Spectrum Parameter	Setting
Attenuation	Auto
Span Frequency	100 MHz
RB / VB (Emission in restricted band)	1MHz / 1MHz for Peak, 1 MHz / 10Hz for Average
RB / VB (Emission in non-restricted band)	100 KHz /100 KHz for Peak

4.8.3. Test Procedures

1. The test procedure is the same as section 4.5.3, only the frequency range investigated is limited to 100MHz around bandedges.
2. In case the emission is fail due to the used RB/VB is too wide, marker-delta method of FCC Public Notice DA00-705 will be followed.

4.8.4. Test Setup Layout

This test setup layout is the same as that shown in section 4.6.4.

4.8.5. Test Deviation

There is no deviation with the original standard.

4.8.6. EUT Operation during Test

The EUT was programmed to be in continuously transmitting mode.

4.8.7. Test Result of Band Edge and Fundamental Emissions

For Bluetooth 2.1 + EDR :

Temperature	23°C	Humidity	65%
Test Engineer	Rion Li	Configurations	Channel 0, 39, 78
Test Date	Dec. 08, 2011	Chain	Mode 1

Channel 0

	Freq	Level	Limit	Over	Read	Cable	Preamp	Antenna	T/Pos	A/Pos	Remark	Pol/Phase
	MHz	dBuV/m	dBuV/m	dB	dBuV	dB	dB	dB/m	deg	cm		
1	2387.60	56.88	74.00	-17.12	26.17	2.84	0.00	27.87	279	100	Peak	VERTICAL
2	2390.00	44.11	54.00	-9.89	13.40	2.84	0.00	27.87	279	100	Average	VERTICAL
3 a	2402.00	88.59				2.84	0.00	27.87	279	100	Average	VERTICAL
4 p	2402.16	105.06				2.84	0.00	27.87	279	100	Peak	VERTICAL

Item 3, 4 are the fundamental frequency at 2402 MHz.

Channel 39

	Freq	Level	Limit	Over	Read	Cable	Preamp	Antenna	T/Pos	A/Pos	Remark	Pol/Phase
	MHz	dBuV/m	dBuV/m	dB	dBuV	dB	dB	dB/m	deg	cm		
1	2373.33	57.46	74.00	-16.54	26.74	2.83	0.00	27.89	206	100	Peak	VERTICAL
2	2390.00	44.08	54.00	-9.92	13.37	2.84	0.00	27.87	206	100	Average	VERTICAL
3 a	2441.00	89.28				2.87	0.00	27.78	206	100	Average	VERTICAL
4 p	2441.32	105.55				2.87	0.00	27.78	206	100	Peak	VERTICAL
5	2483.50	44.24	54.00	-9.76	13.61	2.90	0.00	27.73	206	100	Average	VERTICAL
6	2487.03	56.05	74.00	-17.95	25.42	2.90	0.00	27.73	206	100	Peak	VERTICAL

Item 3, 4 are the fundamental frequency at 2441 MHz.

Channel 78

	Freq	Level	Limit	Over	Read	Cable	Preamp	Antenna	T/Pos	A/Pos	Remark	Pol/Phase
	MHz	dBuV/m	dBuV/m	dB	dBuV	dB	dB	dB/m	deg	cm		
1 p	2479.84	106.26				2.90	0.00	27.73	206	100	Peak	VERTICAL
2 a	2480.00	89.84				2.90	0.00	27.73	206	100	Average	VERTICAL
3	2483.50	46.12	54.00	-7.88	15.49	2.90	0.00	27.73	206	100	Average	VERTICAL
4	2484.94	57.02	74.00	-16.98	26.39	2.90	0.00	27.73	206	100	Peak	VERTICAL

Item 1, 2 are the fundamental frequency at 2480 MHz.

Note:

Emission level (dBuV/m) = 20 log Emission level (uV/m).

Corrected Reading: Antenna Factor + Cable Loss + Read Level - Preamp Factor = Level.

For Bluetooth 2.1 + EDR :

Temperature	23°C	Humidity	65%
Test Engineer	Rion Li	Configurations	Channel 0, 39, 78
Test Date	Dec. 08, 2011	Chain	Mode 2

Channel 0

	Freq	Level	Limit Line	Over Limit	Read Level	Cable Loss	Preamp Factor	Antenna Factor	T/Pos	A/Pos	Remark	Pol/Phase
	MHz	dBuV/m	dBuV/m	dB	dBuV	dB	dB	dB/m	deg	cm		
1	2390.00	55.56	74.00	-18.44	24.85	2.84	0.00	27.87	177	100	Peak	VERTICAL
2	2390.00	45.34	54.00	-8.66	14.63	2.84	0.00	27.87	177	100	Average	VERTICAL
3 p	2402.00	98.80				2.84	0.00	27.87	177	100	Peak	VERTICAL
4 a	2402.00	98.39				2.84	0.00	27.87	177	100	Average	VERTICAL

Item 3, 4 are the fundamental frequency at 2402 MHz.

Channel 39

	Freq	Level	Limit Line	Over Limit	Read Level	Cable Loss	Preamp Factor	Antenna Factor	T/Pos	A/Pos	Remark	Pol/Phase
	MHz	dBuV/m	dBuV/m	dB	dBuV	dB	dB	dB/m	deg	cm		
1	2389.68	55.64	74.00	-18.36	24.93	2.84	0.00	27.87	140	126	Peak	HORIZONTAL
2	2390.00	45.32	54.00	-8.68	14.61	2.84	0.00	27.87	140	126	Average	HORIZONTAL
3 a	2441.00	103.34				2.87	0.00	27.78	140	126	Average	HORIZONTAL
4 p	2441.32	103.78				2.87	0.00	27.78	140	126	Peak	HORIZONTAL
5	2483.50	45.45	54.00	-8.55	14.82	2.90	0.00	27.73	140	126	Average	HORIZONTAL
6	2486.71	56.93	74.00	-17.07	26.30	2.90	0.00	27.73	140	126	Peak	HORIZONTAL

Item 3, 4 are the fundamental frequency at 2441 MHz.

Channel 78

	Freq	Level	Limit Line	Over Limit	Read Level	Cable Loss	Preamp Factor	Antenna Factor	T/Pos	A/Pos	Remark	Pol/Phase
	MHz	dBuV/m	dBuV/m	dB	dBuV	dB	dB	dB/m	deg	cm		
1 p	2480.00	104.46				2.90	0.00	27.73	144	152	Peak	HORIZONTAL
2 a	2480.00	104.04				2.90	0.00	27.73	144	152	Average	HORIZONTAL
3	2483.50	54.79	74.00	-19.21	24.16	2.90	0.00	27.73	144	152	Peak	HORIZONTAL
4	2483.50	46.33	54.00	-7.67	15.70	2.90	0.00	27.73	144	152	Average	HORIZONTAL

Item 1, 2 are the fundamental frequency at 2480 MHz.

Note:

Emission level (dBuV/m) = 20 log Emission level (uV/m).

Corrected Reading: Antenna Factor + Cable Loss + Read Level - Preamp Factor = Level.

For Bluetooth 4.0 :

Temperature	23°C	Humidity	65%
Test Engineer	Rion Li	Configurations	Channel 0, 19, 39
Test Date	Dec. 08, 2011	Chain	Mode 1

Channel 0

	Freq	Level	Limit	Over	Read	Cable	Preamp	Antenna	T/Pos	A/Pos	Remark	Pol/Phase
	MHz	dBuV/m	dBuV/m	dB	dBuV	dB	dB	dB/m	deg	cm		
1	2386.47	57.28	74.00	-16.72	26.57	2.84	0.00	27.87	36	100	Peak	VERTICAL
2	2390.00	45.36	54.00	-8.64	14.65	2.84	0.00	27.87	36	100	Average	VERTICAL
3 a	2402.00	84.46				2.84	0.00	27.87	36	100	Average	VERTICAL
4 p	2402.32	108.36				2.84	0.00	27.87	36	100	Peak	VERTICAL

Item 3, 4 are the fundamental frequency at 2402 MHz.

Channel 19

	Freq	Level	Limit	Over	Read	Cable	Preamp	Antenna	T/Pos	A/Pos	Remark	Pol/Phase
	MHz	dBuV/m	dBuV/m	dB	dBuV	dB	dB	dB/m	deg	cm		
1	2385.83	56.59	74.00	-17.41	25.88	2.84	0.00	27.87	35	100	Peak	VERTICAL
2	2390.00	45.39	54.00	-8.61	14.68	2.84	0.00	27.87	35	100	Average	VERTICAL
3 p	2439.96	108.63				2.87	0.00	27.78	35	100	Peak	VERTICAL
4 a	2439.96	84.99				2.87	0.00	27.78	35	100	Average	VERTICAL
5	2483.50	45.47	54.00	-8.53	14.84	2.90	0.00	27.73	35	100	Average	VERTICAL
6	2516.83	57.17	74.00	-16.83	26.50	2.92	0.00	27.75	35	100	Peak	VERTICAL

Item 3, 4 are the fundamental frequency at 2441 MHz.

Channel 39

	Freq	Level	Limit	Over	Read	Cable	Preamp	Antenna	T/Pos	A/Pos	Remark	Pol/Phase
	MHz	dBuV/m	dBuV/m	dB	dBuV	dB	dB	dB/m	deg	cm		
1 p	2479.84	107.78				2.90	0.00	27.73	148	100	Peak	VERTICAL
2 a	2480.00	84.53				2.90	0.00	27.73	148	100	Average	VERTICAL
3 !	2483.50	68.25	74.00	-5.75	37.62	2.90	0.00	27.73	148	100	Peak	VERTICAL
4 !	2483.50	51.48	54.00	-2.52	20.85	2.90	0.00	27.73	148	100	Average	VERTICAL

Item 1, 2 are the fundamental frequency at 2480 MHz.

Note:

Emission level (dBuV/m) = 20 log Emission level (uV/m).

Corrected Reading: Antenna Factor + Cable Loss + Read Level - Preamp Factor = Level.

For Bluetooth 4.0 :

Temperature	23°C	Humidity	65%
Test Engineer	Rion Li	Configurations	Channel 0, 19, 39
Test Date	Dec. 08, 2011	Chain	Mode 2

Channel 0

	Freq	Level	Limit Line	Over Limit	Read Level	Cable Loss	Preamp Factor	Antenna Factor	T/Pos	A/Pos	Remark	Pol/Phase
	MHz	dBuV/m	dBuV/m	dB	dBuV	dB	dB	dB/m	deg	cm		
1	2389.52	56.87	74.00	-17.13	26.16	2.84	0.00	27.87	172	135	Peak	VERTICAL
2	2390.00	45.79	54.00	-8.21	15.08	2.84	0.00	27.87	172	135	Average	VERTICAL
3 a	2402.00	97.42				2.84	0.00	27.87	172	135	Average	VERTICAL
4 p	2402.32	102.26				2.84	0.00	27.87	172	135	Peak	VERTICAL

Item 3, 4 are the fundamental frequency at 2402 MHz.

Channel 19

	Freq	Level	Limit Line	Over Limit	Read Level	Cable Loss	Preamp Factor	Antenna Factor	T/Pos	A/Pos	Remark	Pol/Phase
	MHz	dBuV/m	dBuV/m	dB	dBuV	dB	dB	dB/m	deg	cm		
1	2383.27	57.63	74.00	-16.37	26.91	2.83	0.00	27.89	240	100	Peak	VERTICAL
2	2390.00	45.37	54.00	-8.63	14.66	2.84	0.00	27.87	240	100	Average	VERTICAL
3 p	2440.01	100.35			69.70	2.87	0.00	27.78	240	100	Peak	VERTICAL
4 a	2440.01	79.40			48.75	2.87	0.00	27.78	240	100	Average	VERTICAL
5	2483.50	45.51	54.00	-8.49	14.88	2.90	0.00	27.73	240	100	Average	VERTICAL
6	2510.42	57.98	74.00	-16.02	27.31	2.92	0.00	27.75	240	100	Peak	VERTICAL

Item 3, 4 are the fundamental frequency at 2441 MHz.

Channel 39

	Freq	Level	Limit Line	Over Limit	Read Level	Cable Loss	Preamp Factor	Antenna Factor	T/Pos	A/Pos	Remark	Pol/Phase
	MHz	dBuV/m	dBuV/m	dB	dBuV	dB	dB	dB/m	deg	cm		
1 p	2479.84	108.66				2.90	0.00	27.73	85	182	Peak	HORIZONTAL
2 a	2480.00	85.04				2.90	0.00	27.73	85	182	Average	HORIZONTAL
3	2483.50	67.72	74.00	-6.28	37.09	2.90	0.00	27.73	85	182	Peak	HORIZONTAL
4 !	2483.50	51.17	54.00	-2.83	20.54	2.90	0.00	27.73	85	182	Average	HORIZONTAL

Item 1, 2 are the fundamental frequency at 2480 MHz.

Note:

Emission level (dBuV/m) = 20 log Emission level (uV/m).

Corrected Reading: Antenna Factor + Cable Loss + Read Level - Preamp Factor = Level.

For Emission not in Restricted Band

For Bluetooth 2.1 + EDR :

Low Band Edge Plot on Channel 0 / 2402 MHz / Mode 1

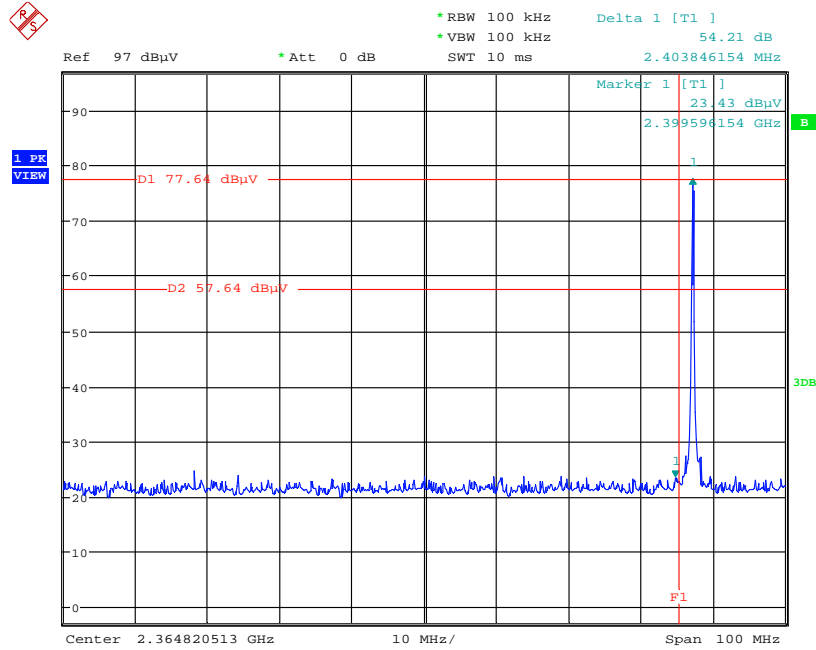

Date: 9.DEC.2011 20:22:51

High Band Edge Plot on Channel 78 / 2480 MHz / Mode 1

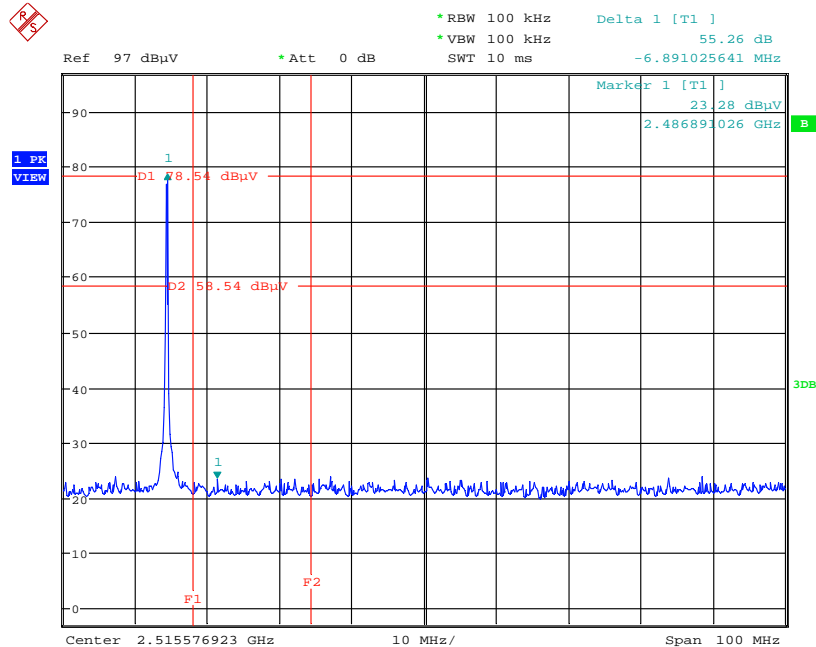

Date: 9.DEC.2011 20:29:12

For Bluetooth 2.1 + EDR :

Low Band Edge Plot on Channel 0 / 2402 MHz / Mode 2

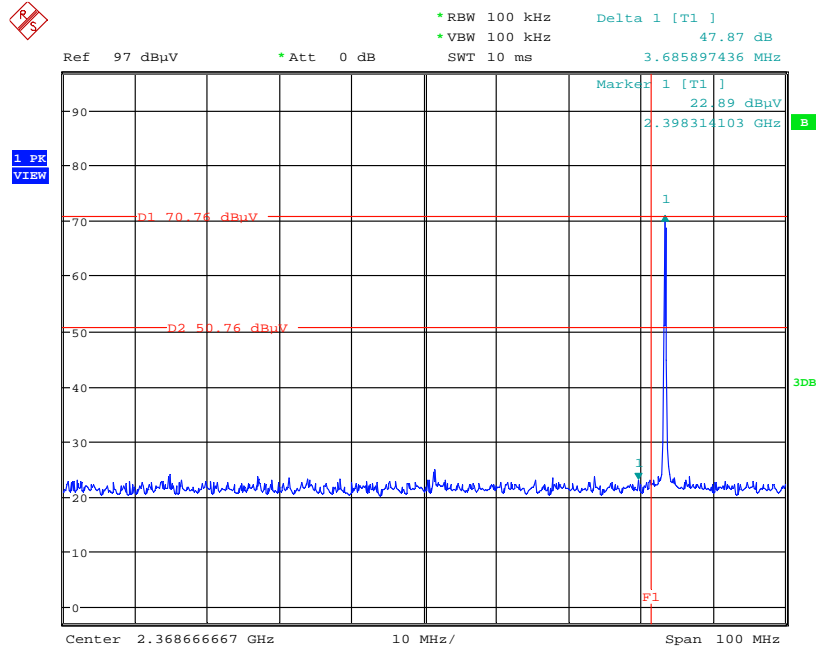

Date: 9.DEC.2011 19:01:14

High Band Edge Plot on Channel 78 / 2480 MHz / Mode 2

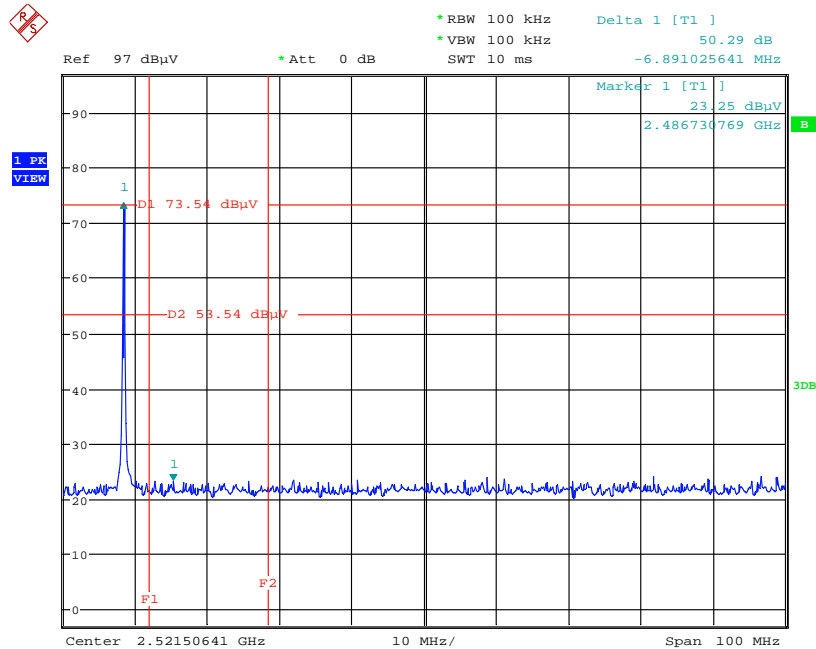

Date: 9.DEC.2011 19:37:58

For Bluetooth 4.0 :

Low Band Edge Plot on Channel 0 / 2402 MHz / Mode 1

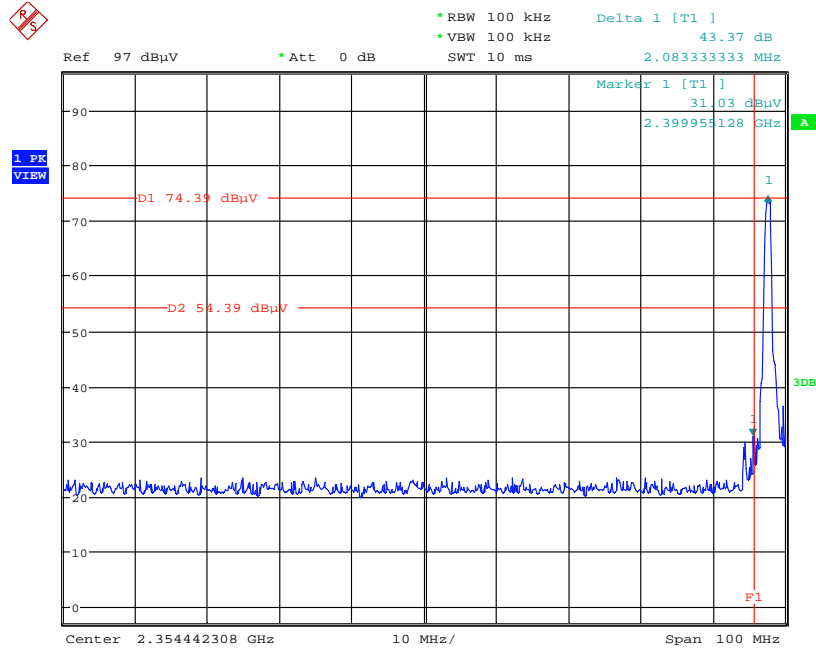

Date: 12.DEC.2011 15:18:33

High Band Edge Plot on Channel 39 / 2480 MHz / Mode 1

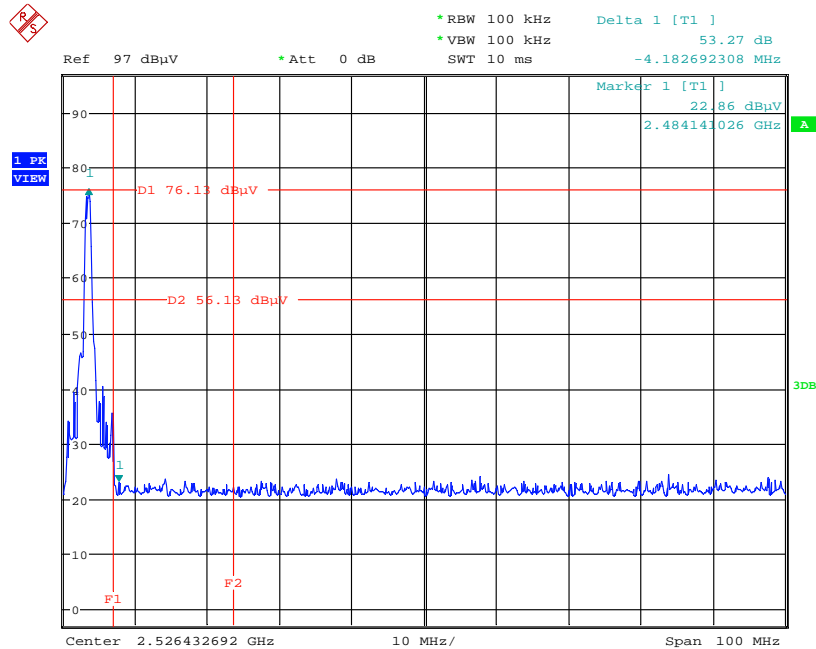

Date: 12.DEC.2011 15:15:45



For Bluetooth 4.0 :
Low Band Edge Plot on Channel 0 / 2402 MHz / Mode 2

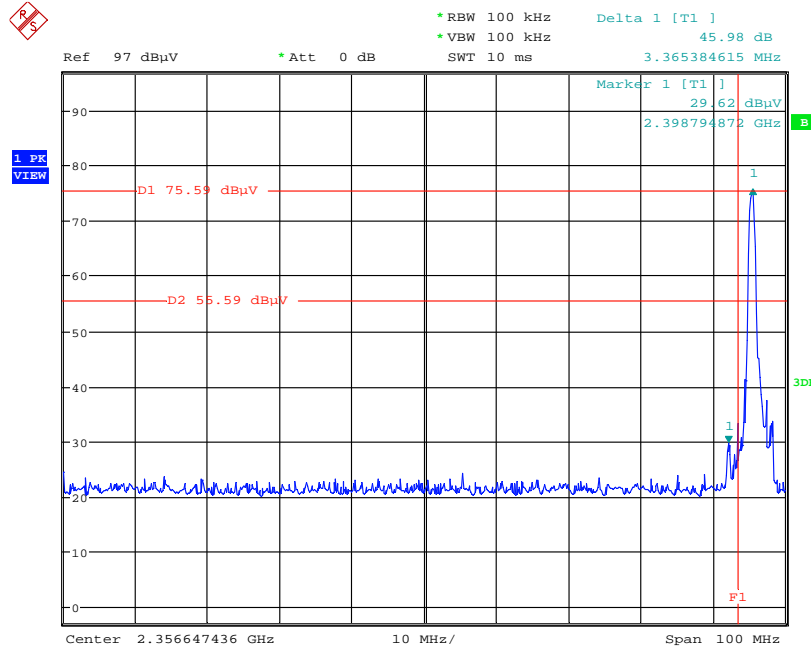

Date: 12.DEC.2011 16:57:00

High Band Edge Plot on Channel 39 / 2480 MHz / Mode 2

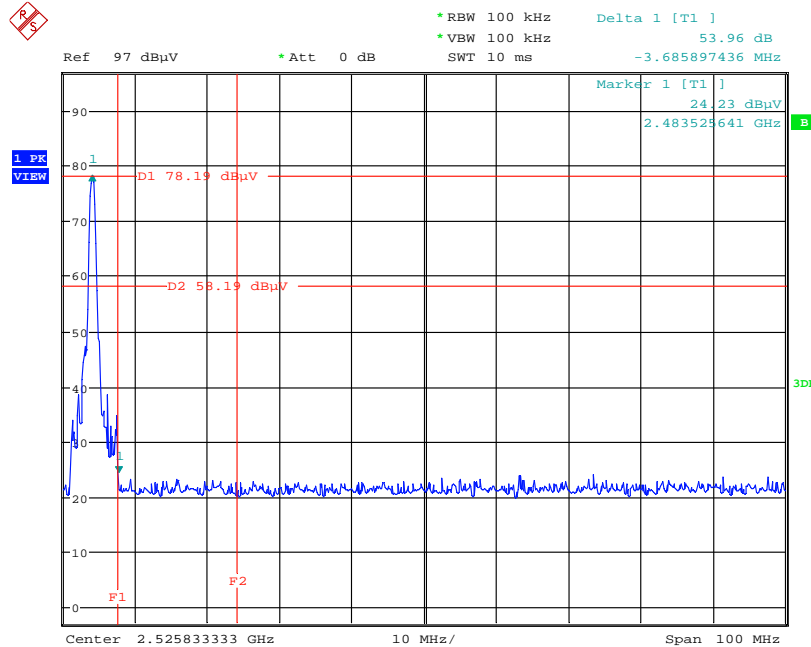

Date: 12.DEC.2011 16:59:18

4.9. Antenna Requirements

4.9.1. Limit

Except for special regulations, the Low-power Radio-frequency Devices must not be equipped with any jacket for installing an antenna with extension cable. An intentional radiator shall be designed to ensure that no antenna other than that furnished by the responsible party shall be used with the device. The use of a permanently attached antenna or of an antenna that uses a unique coupling to the intentional radiator shall be considered sufficient to comply with the provisions of this Section. The manufacturer may design the unit so that the user can replace a broken antenna, but the use of a standard antenna jack or electrical connector is prohibited. Further, this requirement does not apply to intentional radiators that must be professionally installed.

4.9.2. Antenna Connector Construction

Please refer to section 3.3 in this test report, antenna connector complied with the requirements.

5. LIST OF MEASURING EQUIPMENTS

Instrument	Manufacturer	Model No.	Serial No.	Characteristics	Calibration Date	Remark
EMI Test Receiver	R&S	ESCS 30	100377	9kHz ~ 2.75GHz	Sep. 14, 2011	Conduction (CO01-CB)
LISN	F.C.C.	FCC-LISN-50-16-2	04083	150kHz ~ 100MHz	Oct. 28, 2011	Conduction (CO01-CB)
V- LISN	Schwarzbeck	NSLK 8127	8127-478	9K ~ 30MHz	Nov. 16, 2011	Conduction (CO01-CB)
PULSE LIMITER	R&S	ESH3-Z2	100430	9K-30MHz	Jan. 04, 2011	Conduction (CO01-CB)
COND Cable	-	Cable	-	0.15MHz~30MHz	Dec. 4, 2011	Conduction (CO01-CB)
BILOG ANTENNA	Schaffner	CBL6112D	22021	20MHz ~ 2GHz	Oct. 29, 2011	Radiation (03CH01-CB)
Horn Antenna	EMCO	3115	00075790	750MHz~18GHz	Nov. 22, 2011	Radiation (03CH01-CB)
Horn Antenna	SCHWARZBEAK	BBHA 9170	BBHA9170252	15GHz ~ 40GHz	Nov. 22, 2011	Radiation (03CH01-CB)
Pre-Amplifier	Agilent	8447D	2944A10991	0.1MHz ~ 1.3GHz	Nov. 17, 2011	Radiation (03CH01-CB)
Pre-Amplifier	Agilent	8449B	3008A02310	1GHz ~ 26.5GHz	Nov. 23, 2011	Radiation (03CH01-CB)
Pre-Amplifier	WM	TF-130N-R1	923365	26.5GHz ~ 40GHz	Jul. 29, 2011	Radiation (03CH01-CB)
Spectrum analyzer	R&S	FSP40	100056	9KHz~40GHz	Nov. 03, 2011	Radiation (03CH01-CB)
EMI Test Receiver	R&S	ESCS 30	100355	9KHz ~ 2.75GHz	Mar. 22, 2011	Radiation (03CH01-CB)
Loop Antenna	Teseq	HLA 6120	24155	9 kHz - 30 MHz	Sep. 09, 2010*	Radiation (03CH01-CB)
Turn Table	INN CO	CO 2000	N/A	0 ~ 360 degree	N/A	Radiation (03CH01-CB)
Antenna Mast	INN CO	CO2000	N/A	1 m - 4 m	N/A	Radiation (03CH01-CB)
RF Cable-low	Woken	Low Cable-1	N/A	30 MHz - 1 GHz	Nov. 17, 2011	Radiation (03CH01-CB)
RF Cable-high	Woken	High Cable-1	N/A	1 GHz – 26.5 GHz	Nov. 17, 2011	Radiation (03CH01-CB)
RF Cable-high	Woken	High Cable-2	N/A	1 GHz – 26.5 GHz	Nov. 17, 2011	Radiation (03CH01-CB)
RF Cable-high	Woken	High Cable-3	N/A	1 GHz - 40 GHz	Nov. 17, 2011	Radiation (03CH01-CB)
RF Cable-high	Woken	High Cable-4	N/A	1 GHz - 40 GHz	Nov. 17, 2011	Radiation (03CH01-CB)
Spectrum analyzer	R&S	FSV30	101026	9KHz~30GHz	Jul. 27, 2011	Conducted (TH01-CB)
Temp. and Humidity Chamber	Ten Billion	TTH-D3SP	TBN-931011	-30~100 degree	May 20, 2011	Conducted (TH01-CB)
Thermo-Hygro Meter	N/A	HC 520	#1	15~70 degree	Nov. 02, 2011	Conducted (TH01-CB)
RF Power Divider	HP	11636A	00306	2GHz ~ 18GHz	N/A	Conducted (TH01-CB)

Instrument	Manufacturer	Model No.	Serial No.	Characteristics	Calibration Date	Remark
RF Power Splitter	Anaren	44100	1839	2GHz ~ 18GHz	N/A	Conducted (TH01-CB)
RF Power Splitter	Anaren	42100	17930	2GHz ~ 18GHz	N/A	Conducted (TH01-CB)
RF Cable-high	Woken	High Cable-7	-	1 GHz – 26.5 GHz	Nov. 17, 2011	Conducted (TH01-CB)
RF Cable-high	Woken	High Cable-8	-	1 GHz – 26.5 GHz	Nov. 17, 2011	Conducted (TH01-CB)
RF Cable-high	Woken	High Cable-9	-	1 GHz – 26.5 GHz	Nov. 17, 2011	Conducted (TH01-CB)
RF Cable-high	Woken	High Cable-10	-	1 GHz – 26.5 GHz	Nov. 17, 2011	Conducted (TH01-CB)
RF Cable-high	Woken	High Cable-11	-	1 GHz – 26.5 GHz	Nov. 17, 2011	Conducted (TH01-CB)
RF Cable-high	Woken	High Cable-12	-	1 GHz – 26.5 GHz	Nov. 17, 2011	Conducted (TH01-CB)
RF Cable-high	Woken	High Cable-13	-	1 GHz – 26.5 GHz	Nov. 17, 2011	Conducted (TH01-CB)
Power Sensor	Anritsu	MA2411B	0917223	300MHz~40GHz	Nov. 01, 2011	Conducted (TH01-CB)
Power Meter	Anritsu	ML2495A	1035008	300MHz~40GHz	Nov. 01, 2011	Conducted (TH01-CB)

Note: Calibration Interval of instruments listed above is one year.

Note: “*” Calibration Interval of instruments listed above is two years.

6. TEST LOCATION

SHIJR	ADD : 6Fl., No. 106, Sec. 1, Shintai 5th Rd., Shijr City, Taipei, Taiwan 221, R.O.C. TEL : 886-2-2696-2468 FAX : 886-2-2696-2255
HWA YA	ADD : No. 52, Hwa Ya 1st Rd., Kwei-Shan Hsiang, Tao Yuan Hsien, Taiwan, R.O.C. TEL : 886-3-327-3456 FAX : 886-3-318-0055
LINKOU	ADD : No. 30-2, Dingfu Tsuen, Linkou Shiang, Taipei, Taiwan 244, R.O.C TEL : 886-2-2601-1640 FAX : 886-2-2601-1695
DUNGHU	ADD : No. 3, Lane 238, Kangle St., Neihu Chiu, Taipei, Taiwan 114, R.O.C. TEL : 886-2-2631-4739 FAX : 886-2-2631-9740
JUNGHE	ADD : 7Fl., No. 758, Jungjeng Rd., Junghe City, Taipei, Taiwan 235, R.O.C. TEL : 886-2-8227-2020 FAX : 886-2-8227-2626
NEIHU	ADD : 4Fl., No. 339, Hsin Hu 2 nd Rd., Taipei 114, Taiwan, R.O.C. TEL : 886-2-2794-8886 FAX : 886-2-2794-9777
JHUBEI	ADD : No.8, Lane 724, Bo-ai St., Jhubei City, HsinChu County 302, Taiwan, R.O.C. TEL : 886-3-656-9065 FAX : 886-3-656-9085

7. TAF CERTIFICATE OF ACCREDITATION



Certificate No. : L1190-110702

財團法人全國認證基金會
Taiwan Accreditation Foundation

Certificate of Accreditation

This is to certify that

Sporton International Inc.

EMC & Wireless Communications Laboratory

No.52, Hwa Ya 1st Road, Hwa Ya Technology Park, Kwei-Shan Hsiang, Tao Yuan Hsien,
Taiwan, R.O.C.

is accredited in respect of laboratory

Accreditation Criteria : ISO/IEC 17025:2005
Accreditation Number : 1190
Originally Accredited : December 15, 2003
Effective Period : January 10, 2010 to January 09, 2013
Accredited Scope : Testing Field, see described in the Appendix
Specific Accreditation Program : Accreditation Program for Designated Testing Laboratory for Commodities Inspection
Accreditation Program for Telecommunication Equipment Testing Laboratory
Accreditation Program for BSMI Mutual Recognition Arrangement with Foreign Authorities



Jay-San Chen
President, Taiwan Accreditation Foundation
Date : July 02, 2011

P1, total 22 pages

The Appendix forms an integral part of this Certificate, which shall be invalid when use without the Appendix