

# TEST REPORT

## CERTIFICATE OF CONFORMITY

**Standard:** 47 CFR FCC Part 15, Subpart C (Section 15.247)  
**Report No.:** RFBBUI-WTW-P22031043-2  
**FCC ID:** TX2-RTL8852B  
**Model No.:** RTL8852B  
**Received Date:** 2022/3/24  
**Test Date:** 2022/5/27 ~ 2022/6/21  
**Issued Date:** 2022/8/23

**Applicant:** Realtek Semiconductor Corp.  
**Address:** No. 2, Innovation Road II, Hsinchu Science Park, Hsinchu 300, Taiwan  
**Issued By:** Bureau Veritas Consumer Products Services (H.K.) Ltd., Taoyuan Branch  
Hsin Chu Laboratory  
**Lab Address:** E-2, No.1, Li Hsin 1st Road, Hsinchu Science Park, Hsinchu City 300, Taiwan  
**Test Location:** E-2, No.1, Li Hsin 1st Road, Hsinchu Science Park, Hsinchu City 300, Taiwan  
**FCC Registration /** 723255 / TW2022  
**Designation Number:**

**Approved by:** \_\_\_\_\_, **Date:** 2022/8/23  
May Chen / Manager

This test report consists of 114 pages in total. It may be duplicated completely for legal use with the approval of the applicant. It should not be reproduced except in full, without the written approval of our laboratory. The test results in the report only apply to the tested sample. The test results in this report are traceable to the national or international standards.



Prepared by : Vivian Huang / Specialist

This report is governed by, and incorporates by reference, the Conditions of Testing as posted at the date of issuance of this report at <http://www.bureauveritas.com/home/about-us/our-business/cps/about-us/terms-conditions/> and is intended for your exclusive use. Any copying or replication of this report to or for any other person or entity, or use of our name or trademark, is permitted only with our prior written permission. This report sets forth our findings solely with respect to the test samples identified herein. The results set forth in this report are not indicative or representative of the quality or characteristics of the lot from which a test sample was taken or any similar or identical product unless specifically and expressly noted. Our report includes all of the tests requested by you and the results thereof based upon the information that you provided to us. Measurement uncertainty is only provided upon request for accredited tests. Statements of conformity are based on simple acceptance criteria without taking measurement uncertainty into account, unless otherwise requested in writing. You have 60 days from date of issuance of this report to notify us of any material error or omission caused by our negligence or if you require measurement uncertainty; provided, however, that such notice shall be in writing and shall specifically address the issue you wish to raise. A failure to raise such issue within the prescribed time shall constitute your unqualified acceptance of the completeness of this report, the tests conducted and the correctness of the report contents.

## Table of Contents

<b>Release Control Record</b> .....	<b>4</b>
<b>1 Certificate</b> .....	<b>5</b>
<b>2 Summary of Test Results</b> .....	<b>6</b>
2.1 Measurement Uncertainty .....	6
2.2 Supplementary Information .....	6
<b>3 General Information</b> .....	<b>7</b>
3.1 General Description .....	7
3.2 Antenna Description of EUT .....	8
3.3 Channel List .....	9
3.4 Test Mode Applicability and Tested Channel Detail .....	10
3.5 Duty Cycle of Test Signal .....	11
3.6 Test Program Used and Operation Descriptions .....	12
3.7 Connection Diagram of EUT and Peripheral Devices .....	12
3.8 Configuration of Peripheral Devices and Cable Connections .....	15
<b>4 Test Instruments</b> .....	<b>16</b>
4.1 RF Output Power .....	16
4.2 Number of Hopping Frequency Used .....	16
4.3 Dwell Time on Each Channel .....	16
4.4 Hopping Channel Separation .....	16
4.5 20 dB Bandwidth .....	16
4.6 Conducted Out of Band Emissions .....	16
4.7 AC Power Conducted Emissions .....	17
4.8 Unwanted Emissions below 1 GHz .....	17
4.9 Unwanted Emissions above 1 GHz .....	18
<b>5 Limits of Test Items</b> .....	<b>19</b>
5.1 RF Output Power .....	19
5.2 Number of Hopping Frequency Used .....	19
5.3 Dwell Time on Each Channel .....	19
5.4 Hopping Channel Separation .....	19
5.5 20 dB Bandwidth .....	19
5.6 Conducted Out of Band Emissions .....	19
5.7 AC Power Conducted Emissions .....	19
5.8 Unwanted Emissions below 1 GHz .....	20
5.9 Unwanted Emissions above 1 GHz .....	20
<b>6 Test Arrangements</b> .....	<b>21</b>
6.1 RF Output Power .....	21
6.1.1 Test Setup .....	21
6.1.2 Test Procedure .....	21
6.2 Number of Hopping Frequency Used .....	21
6.2.1 Test Setup .....	21
6.2.2 Test Procedure .....	21
6.3 Dwell Time on Each Channel .....	22
6.3.1 Test Setup .....	22
6.3.2 Test Procedure .....	22
6.4 Hopping Channel Separation .....	22
6.4.1 Test Setup .....	22
6.4.2 Test Procedure .....	22
6.5 20 dB Bandwidth .....	23
6.5.1 Test Setup .....	23
6.5.2 Test Procedure .....	23
6.6 Conducted Out of Band Emissions .....	23
6.6.1 Test Setup .....	23
6.6.2 Test Procedure .....	23
6.7 AC Power Conducted Emissions .....	24



6.7.1	Test Setup .....	24
6.7.2	Test Procedure.....	24
6.8	Unwanted Emissions below 1 GHz .....	25
6.8.1	Test Setup .....	25
6.8.2	Test Procedure.....	26
6.9	Unwanted Emissions above 1 GHz.....	27
6.9.1	Test Setup .....	27
6.9.2	Test Procedure.....	27
<b>7</b>	<b>Test Results of Test Item .....</b>	<b>28</b>
7.1	RF Output Power.....	28
7.2	Number of Hopping Frequency Used.....	30
7.3	Dwell Time on Each Channel .....	32
7.4	Hopping Channel Separation .....	36
7.5	20 dB Bandwidth .....	38
7.6	Conducted Out of Band Emissions .....	40
7.7	AC Power Conducted Emissions .....	45
7.8	Unwanted Emissions below 1 GHz .....	49
7.9	Unwanted Emissions above 1 GHz.....	57
<b>8</b>	<b>Pictures of Test Arrangements .....</b>	<b>113</b>
<b>9</b>	<b>Information of the Testing Laboratories .....</b>	<b>114</b>



## Release Control Record

Issue No.	Description	Date Issued
RFBBUI-WTW-P22031043-2	Original release.	2022/8/23

## 1 Certificate

**Product:** 11ax RTL8852B M.2 1216 Combo module

**Brand:** REALTEK

**Test Model:** RTL8852B

**Sample Status:** Engineering sample

**Applicant:** Realtek Semiconductor Corp.

**Test Date:** 2022/5/27 ~ 2022/6/21

**Standard:** 47 CFR FCC Part 15, Subpart C (Section 15.247)

**Measurement** ANSI C63.10-2013

**procedure:** KDB 558074 D01 15.247 Meas Guidance v05r02

The above equipment has been tested by **Bureau Veritas Consumer Products Services (H.K.) Ltd., Taoyuan Branch**, and found compliance with the requirement of the above standards. The test record, data evaluation & Equipment Under Test (EUT) configurations represented herein are true and accurate accounts of the measurements of the sample's RF characteristics under the conditions specified in this report.

## 2 Summary of Test Results

47 CFR FCC Part 15, Subpart C (Section 15.247)			
Standard / Clause	Test Item	Result	Remark
15.247 (a)(1)	RF Output Power	Pass	Meet the requirement of limit.
15.247(a)(1) (iii)	Number of Hopping Frequency Used	Pass	Meet the requirement of limit.
15.247(a)(1) (iii)	Dwell Time on Each Channel	Pass	Meet the requirement of limit.
15.247(a)(1)	Hopping Channel Separation	Pass	Meet the requirement of limit.
15.247(a)(1)	20 dB Bandwidth	-	Refer to note 1
15.247(d)	Conducted Out of Band Emissions	Pass	Meet the requirement of limit.
15.207	AC Power Conducted Emissions	Pass	Minimum passing margin is -13.28 dB at 25.87500 MHz
15.205 / 15.209 / 15.247(d)	Unwanted Emissions below 1 GHz	Pass	Minimum passing margin is -3.3 dB at 234.66 MHz
15.205 / 15.209 / 15.247(d)	Unwanted Emissions above 1 GHz	Pass	Minimum passing margin is -9.6 dB at 2483.50 MHz
15.203	Antenna Requirement	Pass	Antenna connector is ipex(MHF) not a standard connector.

### Notes:

1. If the Frequency Hopping System operating in 2400-2483.5 MHz band and the output power less than 125 mW. The hopping channel carrier frequencies separated by a minimum of 25 kHz or two-thirds of the 20 dB bandwidth of hopping channel whichever is greater.
2. Determining compliance based on the results of the compliance measurement, not taking into account measurement instrumentation uncertainty.

### 2.1 Measurement Uncertainty

Where relevant, the following measurement uncertainty levels have been estimated for tests performed on the EUT as specified in CISPR 16-4-2:

Measurement	Specification	Expanded Uncertainty (k=2) (±)
Conducted Out of Band Emissions	9 kHz ~ 40 GHz	2.5 dB
AC Power Conducted Emissions	150 kHz ~ 30 MHz	1.9 dB
Unwanted Emissions below 1 GHz	9 kHz ~ 30 MHz	3.1 dB
	30 MHz ~ 1 GHz	5.1 dB
Unwanted Emissions above 1 GHz	1 GHz ~ 18 GHz	5.1 dB
	18 GHz ~ 40 GHz	5.3 dB

The other instruments specified are routine verified to remain within the calibrated levels, no measurement uncertainty is required to be calculated.

### 2.2 Supplementary Information

There is not any deviation from the test standards for the test method, and no modifications required for compliance.

### 3 General Information

#### 3.1 General Description

Product	11ax RTL8852B M.2 1216 Combo module
Brand	REALTEK
Test Model	RTL8852B
Status of EUT	Engineering sample
Power Supply Rating	3.3Vdc from host equipment
Modulation Type	GFSK, $\pi/4$ -DQPSK, 8DPSK
Modulation Technology	FHSS
Transfer Rate	Up to 3 Mbps
Operating Frequency	2402 ~ 2480 MHz
Number of Channel	79
Output Power	18.197 mW (12.6 dBm)

Note:

1. The EUT has below HW SKU configuration, as below table:

SKU No.	Interface	Description
1	WLAN use PCIe, BT use USB	Dual antenna port
2	WLAN use PCIe, BT use UART	Dual antenna port

2. Simultaneously transmission condition.

Condition	Technology	
1	WLAN 5GHz	Bluetooth

Note: The emission of the simultaneous operation has been evaluated and no non-compliance was found.

3. The above EUT information is declared by manufacturer and for more detailed features description, please refer to the manufacturer's specifications or User's Manual.

### 3.2 Antenna Description of EUT

1. The antenna information is listed as below.

Ant. Set	RF Chain No.	Brand	Model	Ant. Net Gain (dBi)	Frequency Range (GHz)	Ant. Type	Connector Type	Cable Length (mm)
1	Chain 0	ARISTOTLE	RFA-27-JP326-MHF4300	3.5	2.4~2.4835	PIFA	i-pex(MHF)	300
				5	5.15~5.85			
				5	5.875~7.125			
	Chain 1	ARISTOTLE	RFA-27-JP326-MHF4300	3.5	2.4~2.4835	PIFA	i-pex(MHF)	300
				5	5.15~5.85			
				5	5.875~7.125			
2	Chain 0	ARISTOTLE	RFA-27-C38H1-MHF4300	3	2.4~2.4835	Dipole	i-pex(MHF)	300
				5	5.15~5.85			
				5	5.875~7.125			
	Chain 1	ARISTOTLE	RFA-27-C38H1-MHF4300	3	2.4~2.4835	Dipole	i-pex(MHF)	300
				5	5.15~5.85			
				5	5.875~7.125			

Note:

1. The Bluetooth technology will fix transmission on Chain 1.
2. Max. gain was selected for the final test, except for the unwanted emissions test.

\* Detail antenna specification please refer to antenna datasheet and/or antenna measurement report.



### 3.3 Channel List

79 channels are provided for BT-EDR:

Channel	Frequency (MHz)	Channel	Frequency (MHz)	Channel	Frequency (MHz)	Channel	Frequency (MHz)
0	2402	20	2422	40	2442	60	2462
1	2403	21	2423	41	2443	61	2463
2	2404	22	2424	42	2444	62	2464
3	2405	23	2425	43	2445	63	2465
4	2406	24	2426	44	2446	64	2466
5	2407	25	2427	45	2447	65	2467
6	2408	26	2428	46	2448	66	2468
7	2409	27	2429	47	2449	67	2469
8	2410	28	2430	48	2450	68	2470
9	2411	29	2431	49	2451	69	2471
10	2412	30	2432	50	2452	70	2472
11	2413	31	2433	51	2453	71	2473
12	2414	32	2434	52	2454	72	2474
13	2415	33	2435	53	2455	73	2475
14	2416	34	2436	54	2456	74	2476
15	2417	35	2437	55	2457	75	2477
16	2418	36	2438	56	2458	76	2478
17	2419	37	2439	57	2459	77	2479
18	2420	38	2440	58	2460	78	2480
19	2421	39	2441	59	2461		

### 3.4 Test Mode Applicability and Tested Channel Detail

Pre-Scan:	1. EUT has the following interfaces: PCIe+USB interface/PCIe+UART interface. These interfaces are pre-scanned for worst-case scenarios as representative test conditions. 2. PIFA ANT can be used in the following ways: X / Y / Z axis. Pre-scan in these ways and find the worst case as a representative test condition.
Worst Case:	1. EUT interfaces Worst Condition: Unwanted Emissions below 1 GHz PCIe+UART interface worst ; Unwanted Emissions above 1 GHz PCIe+USB interface worst ; AC Power Conducted Emissions PCIe+UART interface worst. 2. PIFA ANT the worst case was found when positioned on (X / Y / Z axis): X 3. Pre-Scan has been conducted to determine the worst-case mode from all possible combinations between available modulations, data rates and antenna ports (if EUT with antenna diversity architecture).

Following channel(s) was (were) selected for the final test as listed below:

Test Item	EUT Configure Mode	Tested Channel	Modulation	Data Rate Parameter
AC Power Conducted Emissions	C, D	39	GFSK	DH5
Unwanted Emissions below 1 GHz	A, B, C, D	39	GFSK	DH5
Unwanted Emissions above 1 GHz	A, B, C, D	0, 39, 78	GFSK	DH5
			8DPSK	3DH5
RF Output Power / Hopping Channel Separation / 20 dB Bandwidth	E, F	0, 39, 78	GFSK	DH5
			8DPSK	3DH5
Number of Hopping Frequency Used	E, F	Hopping	GFSK	DH5
			8DPSK	3DH5
Conducted Out of Band Emissions	E, F	Hopping 0,78	GFSK	DH5
			8DPSK	3DH5
Dwell Time on Each Channel	E, F	Hopping	GFSK	DH1/ DH3/ DH5
			8DPSK	3DH1/ 3DH3/ 3DH5
EUT Configure Mode:	A	Low Power with Dipole Antenna		
	B	High Power with Dipole Antenna		
	C	Low Power with PIFA Antenna		
	D	High Power with PIFA Antenna		
	E	Low Power (Antenna Port)		
	F	High Power(Antenna Port)		

Note: Bluetooth output power is divided into Low Power(6dBm) and High Power(12dBm), both need to be tested.

### 3.5 Duty Cycle of Test Signal

**GFSK:** Duty cycle = 4.2 ms / 100 ms x 100% = 4.2%

**8DPSK:** Duty cycle = 4 ms / 100 ms x 100% = 4.0%

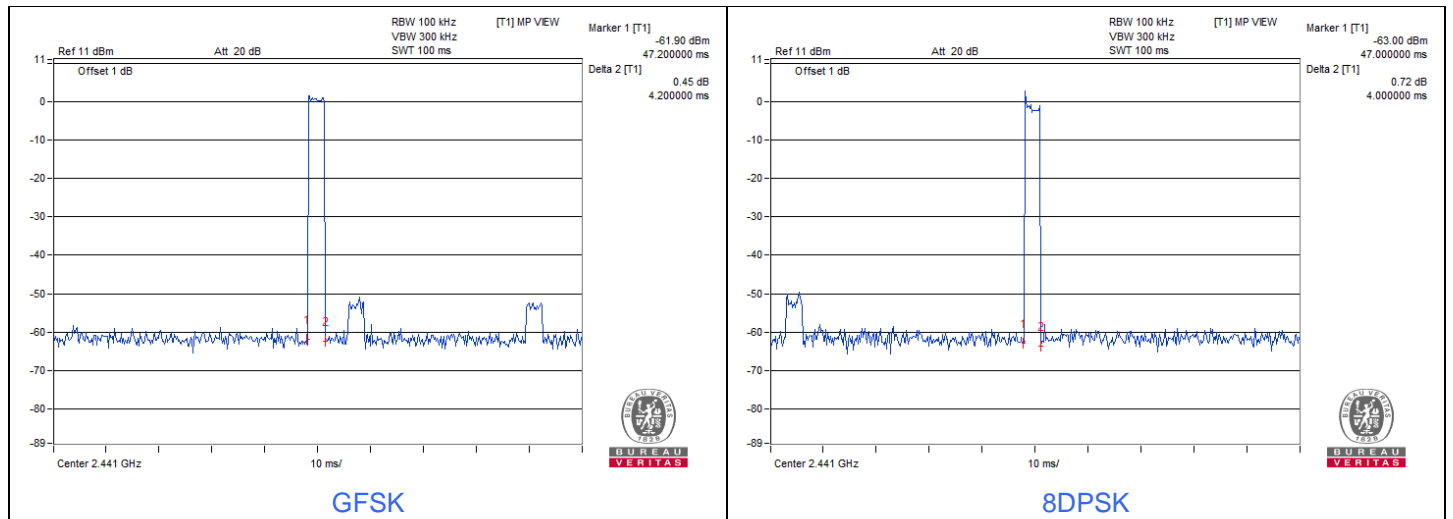

### 3.6 Test Program Used and Operation Descriptions

Controlling software (Bluetooth RF test tool (5.3.2.25)) has been activated to set the EUT under transmission condition continuously at specific channel frequency.

### 3.7 Connection Diagram of EUT and Peripheral Devices

#### For Unwanted Emission above 1 GHz test

(PIFA antenna BT PCIe + USB interface + dual antenna port)

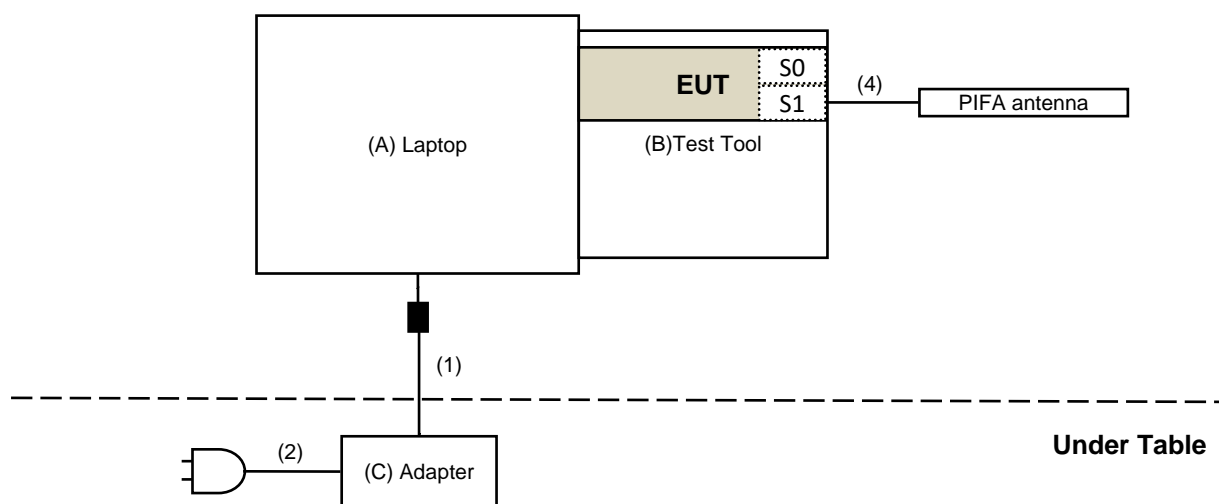

(Dipole antenna BT PCIe + USB interface + dual antenna port)

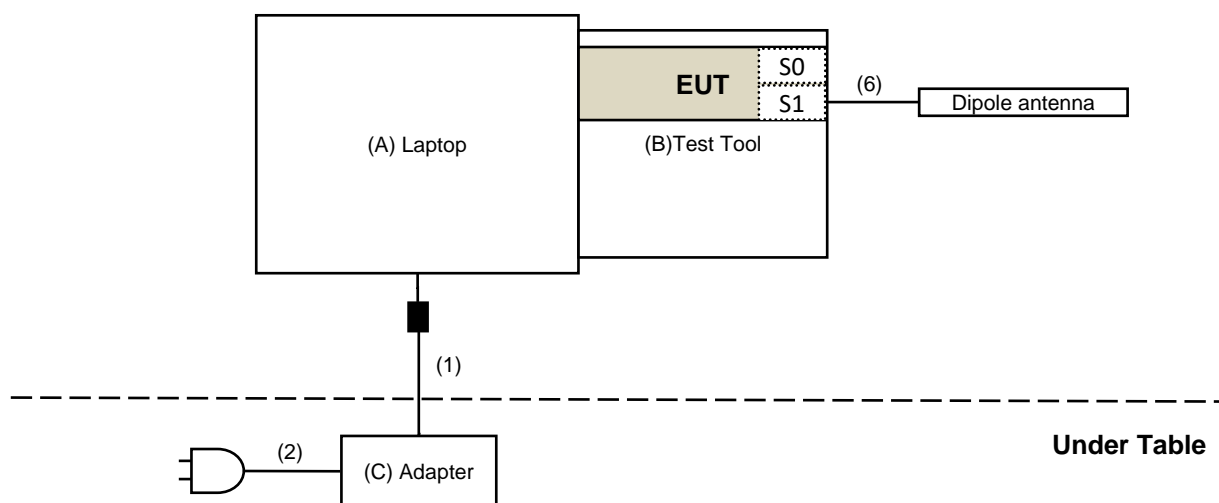

### For Unwanted Emission below 1 GHz test

(PIFA antenna BT PCIe + UART interface + dual antenna port)

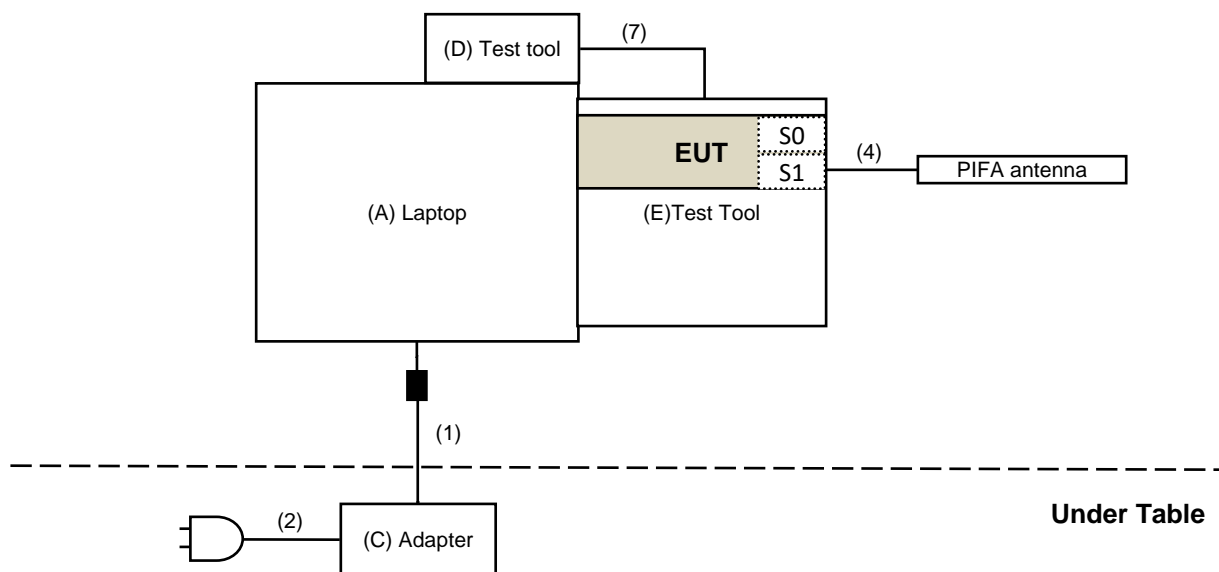

(Dipole antenna BT PCIe + UART interface + dual antenna port)

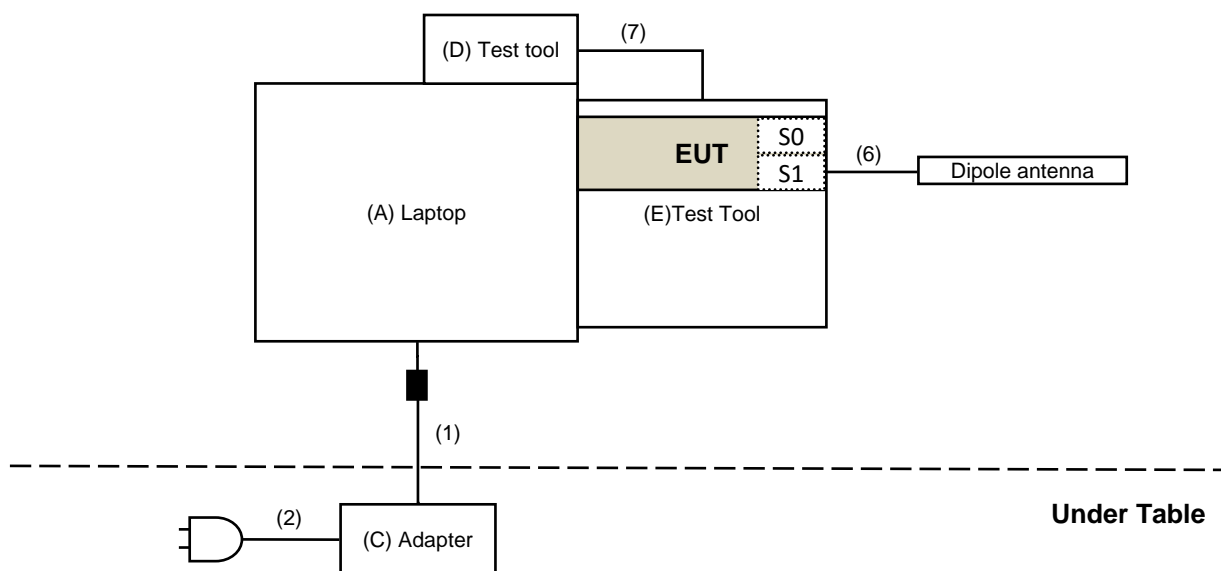

### For AC Power Conducted Emission test

(PIFA antenna 2Tx PCIe + UART interface + dual antenna port)

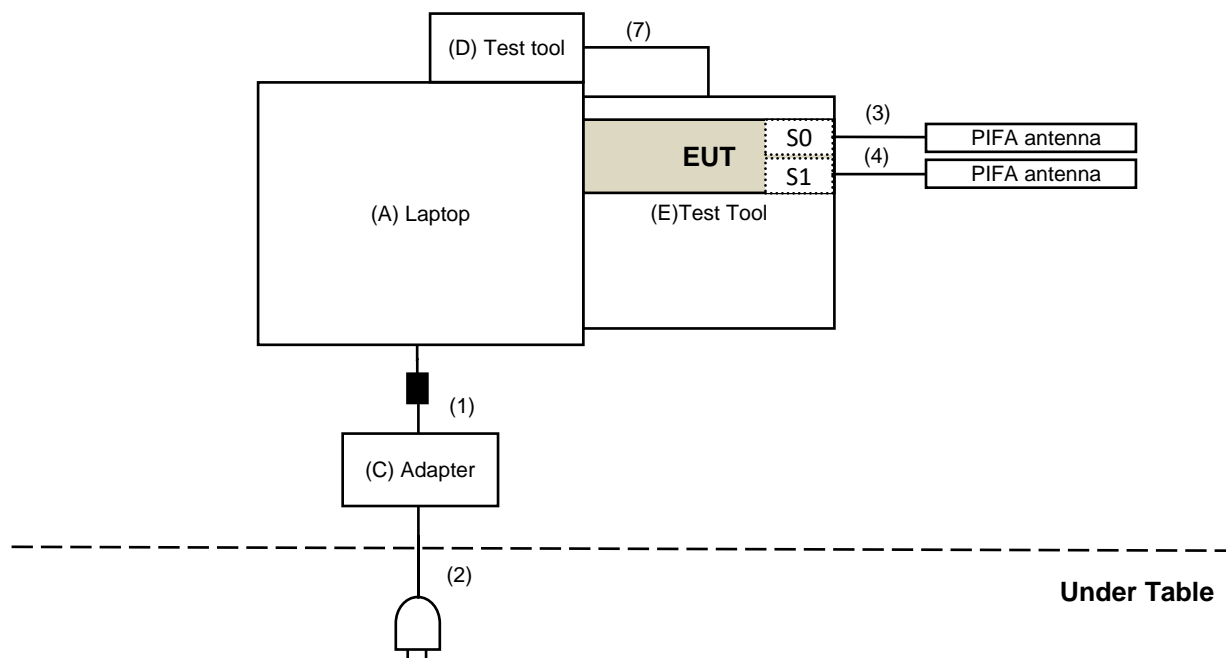

### 3.8 Configuration of Peripheral Devices and Cable Connections

ID	Product	Brand	Model No.	Serial No.	FCC ID	Remarks
A	Laptop	DELL	E6420	B92T3R1	FCC DoC	Provided by Lab
B	Test Tool	Realtek	N/A	N/A	N/A	Supplied by applicant
C	Adapter	DELL	LA65NS2-01	N/A	N/A	Provided by Lab
D	Test Tool	Realtek	N/A	N/A	N/A	Supplied by applicant
E	Test Tool	Realtek	N/A	N/A	N/A	Supplied by applicant

ID	Cable Descriptions	Qty.	Length (m)	Shielding (Yes/No)	Cores (Qty.)	Remarks
1	DC Cable	1	1.8	No	1	Provided by Lab
2	AC Cable	1	1	No	0	Provided by Lab
3	RF Cable	1	0.3	No	0	Supplied by applicant
4	RF Cable	1	0.3	No	0	Supplied by applicant
5	RF Cable	1	0.3	No	0	Supplied by applicant
6	RF Cable	1	0.3	No	0	Supplied by applicant
7	Data Cable	1	0.2	No	0	Supplied by applicant

## 4 Test Instruments

The calibration interval of the all test instruments are 12 months and the calibrations are traceable to NML/ROC and NIST/USA.

### 4.1 RF Output Power

Description Manufacturer	Model No.	Serial No.	Calibrated Date	Calibrated Until
Attenuator WOKEN	MDCS18N-10	MDCS18N-10-01	2022/4/5	2023/4/4
Power Meter Anritsu	ML2495A	1529002	2021/6/21	2022/6/20
Pulse Power Sensor Anritsu	MA2411B	1726434	2021/6/21	2022/6/20
Software	ADT_RF Test Software V6.6.5.4	N/A	N/A	N/A

Notes:

1. The test was performed in Oven room 2.
2. Tested Date: 2022/5/31 ~ 2022/6/1

### 4.2 Number of Hopping Frequency Used

Description Manufacturer	Model No.	Serial No.	Calibrated Date	Calibrated Until
Attenuator WOKEN	MDCS18N-10	MDCS18N-10-01	2022/4/5	2023/4/4
Software	ADT_RF Test Software V6.6.5.4	N/A	N/A	N/A
Spectrum Analyzer R&S	FSV40	101516	2022/3/7	2023/3/6

Notes:

1. The test was performed in Oven room 2.
2. Tested Date: 2022/5/31 ~ 2022/6/1

### 4.3 Dwell Time on Each Channel

Refer to section 4.2 to get information of the instruments.

### 4.4 Hopping Channel Separation

Refer to section 4.2 to get information of the instruments.

### 4.5 20 dB Bandwidth

Refer to section 4.2 to get information of the instruments.

### 4.6 Conducted Out of Band Emissions

Refer to section 4.2 to get information of the instruments.



#### 4.7 AC Power Conducted Emissions

Description Manufacturer	Model No.	Serial No.	Calibrated Date	Calibrated Until
50 ohms Terminator	50	3	2021/10/27	2022/10/26
Fixed attenuator STI	STI02-2200-10	005	2021/8/27	2022/8/26
LISN R&S	ESH3-Z5	848773/004	2021/10/29	2022/10/28
RF Coaxial Cable JYEBO	5D-FB	COCCAB-001	2021/9/25	2022/9/24
Software BVADT	BVADT_Cond_V7.3.7.4	N/A	N/A	N/A
TEST RECEIVER R&S	ESCS 30	847124/029	2021/10/13	2022/10/12

Notes:

1. The test was performed in Conduction 1
2. Tested Date: 2022/6/11

#### 4.8 Unwanted Emissions below 1 GHz

Description Manufacturer	Model No.	Serial No.	Calibrated Date	Calibrated Until
Bilog Antenna Schwarzbeck	VULB 9168	9168-0842	2021/10/26	2022/10/25
Boresight Antenna Tower & Turn Table Max-Full	MF-7802BS	MF780208530	N/A	N/A
Fixed attenuator Mini-Circuits	UNAT-5+	PAD-ATT5-02	2022/1/10	2023/1/9
LOOP ANTENNA Electro-Metrics	EM-6879	264	2022/3/18	2023/3/17
Pre_Amplifier Agilent	8447D	2944A10636	2022/3/19	2023/3/18
Pre_Amplifier EMCI	EMC330N	980538	2022/4/25	2023/4/24
RF Coaxial Cable JYEBO	5D-FB	LOOPCAB-001	2022/1/6	2023/1/5
		LOOPCAB-002	2022/1/6	2023/1/5
RF Coaxial Cable COMMATE/PEWC	8D	966-5-1	2022/4/25	2023/4/24
		966-5-2	2022/4/25	2023/4/24
		966-5-3	2022/4/25	2023/4/24
Software	ADT_Radiated_V8.7.08	N/A	N/A	N/A
Spectrum Analyzer Keysight	N9020B	MY60112410	2022/3/13	2023/3/12
Test Receiver R&S	ESR3	102528	2022/2/25	2023/2/24

Notes:

1. The test was performed in 966 Chamber No. 5.
2. Tested Date: 2022/6/13

#### 4.9 Unwanted Emissions above 1 GHz

Description Manufacturer	Model No.	Serial No.	Calibrated Date	Calibrated Until
Boresight Antenna Tower & Turn Table Max-Full	MF-7802BS	MF780208530	N/A	N/A
Horn Antenna Schwarzbeck	BBHA 9120D	9120D-1819	2021/11/14	2022/11/13
	BBHA 9170	9170-739	2021/11/14	2022/11/13
Pre_Amplifier EMCI	EMC12630SE	980509	2022/4/25	2023/4/24
	EMC184045SE	980387	2022/1/10	2023/1/9
RF Cable-Frequency range: 1- 40GHz EMCI	EMC102-KM-KM-1200	160924	2022/1/10	2023/1/9
RF Coaxial Cable EMCI	EMC104-SM-SM-1500	180503	2022/4/25	2023/4/24
	EMC104-SM-SM-2000	180501	2022/4/25	2023/4/24
	EMC104-SM-SM-6000	180506	2022/4/25	2023/4/24
	EMC-KM-KM-4000	200214	2022/3/8	2023/3/7
Software	ADT_Radiated_V8.7.08	N/A	N/A	N/A
Spectrum Analyzer Keysight	N9020B	MY60112410	2022/3/13	2023/3/12
Test Receiver R&S	ESR3	102528	2022/2/25	2023/2/24

Notes:

1. The test was performed in 966 Chamber No. 5.
2. Tested Date: 2022/5/27 ~ 2022/6/21

## 5 Limits of Test Items

### 5.1 RF Output Power

For systems using digital modulation in the 2400–2483.5 MHz bands: 1 Watt (30 dBm)

### 5.2 Number of Hopping Frequency Used

At least 15 channels frequencies, and should be equally spaced.

### 5.3 Dwell Time on Each Channel

The average time of occupancy on any channel shall not be greater than 0.4 seconds within a period of 0.4 seconds multiplied by the number of hopping channels employed.

### 5.4 Hopping Channel Separation

At least 25 kHz or two-third of 20 dB hopping channel bandwidth (whichever is greater).

### 5.5 20 dB Bandwidth

Maximum bandwidth is not specified.

### 5.6 Conducted Out of Band Emissions

Below 20 dB of the highest emission level of operating band (in 100 kHz Resolution Bandwidth).

### 5.7 AC Power Conducted Emissions

Frequency (MHz)	Conducted Limit (dBuV)	
	Quasi-peak	Average
0.15 - 0.5	66 - 56	56 - 46
0.50 - 5.0	56	46
5.0 - 30.0	60	50

Notes:

1. The lower limit shall apply at the transition frequencies.
2. The limit decreases in line with the logarithm of the frequency in the range of 0.15 to 0.50 MHz.

## 5.8 Unwanted Emissions below 1 GHz

Radiated emissions up to 1 GHz which fall in the restricted bands must comply with the radiated emission limits specified as below table. Other emissions shall be at least 20 dB below the highest level of the desired power:

Frequencies (MHz)	Field Strength (microvolts/meter)	Measurement Distance (meters)
0.009 ~ 0.490	2400/F(kHz)	300
0.490 ~ 1.705	24000/F(kHz)	30
1.705 ~ 30.0	30	30
30 ~ 88	100	3
88 ~ 216	150	3
216 ~ 960	200	3
Above 960	500	3

Notes:

1. The lower limit shall apply at the transition frequencies.
2. Emission level (dBuV/m) = 20 log Emission level (uV/m).

## 5.9 Unwanted Emissions above 1 GHz

Radiated emissions above 1 GHz which fall in the restricted bands must comply with the radiated emission limits specified as below table. Other emissions shall be at least 20 dB below the highest level of the desired power:

Frequencies (MHz)	Field Strength (microvolts/meter)	Measurement Distance (meters)
Above 960	500	3

Notes:

1. The lower limit shall apply at the transition frequencies.
2. Emission level (dBuV/m) = 20 log Emission level (uV/m).
3. For frequencies above 1000 MHz, the field strength limits are based on average detector, however, the peak field strength of any emission shall not exceed the maximum permitted average limits, specified above by more than 20 dB under any condition of modulation.

## 6 Test Arrangements

### 6.1 RF Output Power

#### 6.1.1 Test Setup

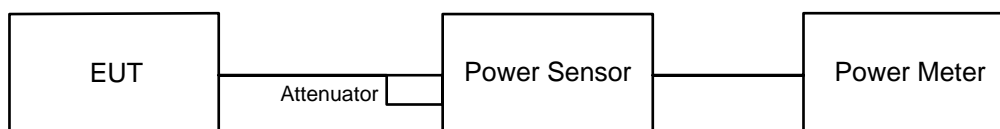

#### 6.1.2 Test Procedure

##### Peak Power:

A peak power sensor was used on the output port of the EUT. A power meter was used to read the response of the peak power sensor. Record the power level.

##### Average Power:

Average power sensor was used to perform output power measurement, trigger and gating function of wide band power meter is enabled to measure max output power of TX on burst. Duty factor is not added to measured value.

### 6.2 Number of Hopping Frequency Used

#### 6.2.1 Test Setup

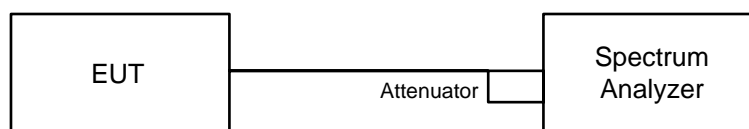

#### 6.2.2 Test Procedure

- Check the calibration of the measuring instrument (SA) using either an internal calibrator or a known signal from an external generator.
- Turn on the EUT and connect its antenna terminal to measurement via a low loss cable. Then set it to any one measured frequency within its operating range and make sure the instrument is operated in its linear range.
- Set the SA on MaxHold Mode, and then keep the EUT in hopping mode. Record all the signals from each channel until each one has been recorded.
- Set the SA on View mode and then plot the result on SA screen.
- Repeat above procedures until all frequencies measured were complete.

## 6.3 Dwell Time on Each Channel

### 6.3.1 Test Setup

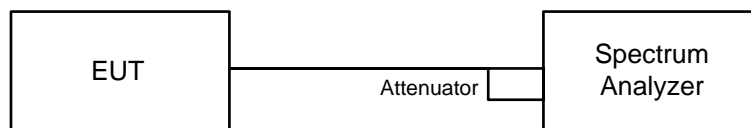

### 6.3.2 Test Procedure

- Check the calibration of the measuring instrument (SA) using either an internal calibrator or a known signal from an external generator.
- Turn on the EUT and connect its antenna terminal to measurement via a low loss cable. Then set it to any one measured frequency within its operating range and make sure the instrument is operated in its linear range.
- Adjust the center frequency of SA on any frequency to be measured and set SA to zero span mode. And then, set RBW and VBW of spectrum analyzer to proper value.
- Measure the time duration of one transmission on the measured frequency. And then plot the result with time difference of this time duration.
- Repeat above procedures until all different time-slot modes have been completed.

## 6.4 Hopping Channel Separation

### 6.4.1 Test Setup

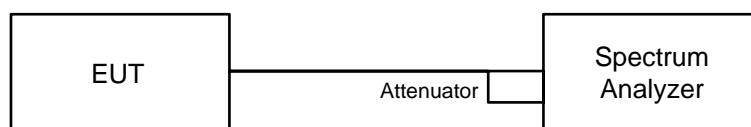

### 6.4.2 Test Procedure

- Check the calibration of the measuring instrument using either an internal calibrator or a known signal from an external generator.
- Turn on the EUT and connect it to measurement instrument. Then set it to any one convenient frequency within its operating range.
- By using the MaxHold function record the separation of two adjacent channels.
- Measure the frequency difference of these two adjacent channels by SA MARK function. And then plot the result on SA screen.
- Repeat above procedures until all frequencies measured were complete.

## 6.5 20 dB Bandwidth

### 6.5.1 Test Setup

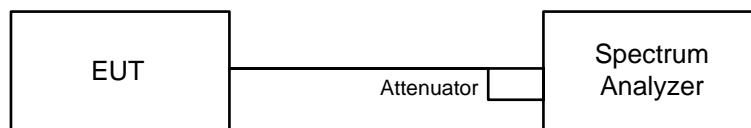

### 6.5.2 Test Procedure

- Check the calibration of the measuring instrument using either an internal calibrator or a known signal from an external generator.
- Turn on the EUT and connect it to measurement instrument. Then set it to any one convenient frequency within its operating range. Set a reference level on the measuring instrument equal to the highest peak value.
- Measure the frequency difference of two frequencies that were attenuated 20 dB from the reference level. Record the frequency difference as the emission bandwidth.
- Repeat above procedures until all frequencies measured were complete.

## 6.6 Conducted Out of Band Emissions

### 6.6.1 Test Setup



### 6.6.2 Test Procedure

#### MEASUREMENT PROCEDURE REF

- Set the RBW = 100 kHz.
- Set the VBW  $\geq$  300 kHz.
- Detector = peak.
- Sweep time = auto couple.
- Trace mode = max hold.
- Allow trace to fully stabilize.
- Use the peak marker function to determine the maximum power level in any 100 kHz band segment within the fundamental EBW.

#### MEASUREMENT PROCEDURE OOB

- Set RBW = 100 kHz.
- Set VBW  $\geq$  300 kHz.
- Detector = peak.
- Sweep = auto couple.
- Trace Mode = max hold.
- Allow trace to fully stabilize.
- Use the peak marker function to determine the maximum amplitude level.

## 6.7 AC Power Conducted Emissions

### 6.7.1 Test Setup

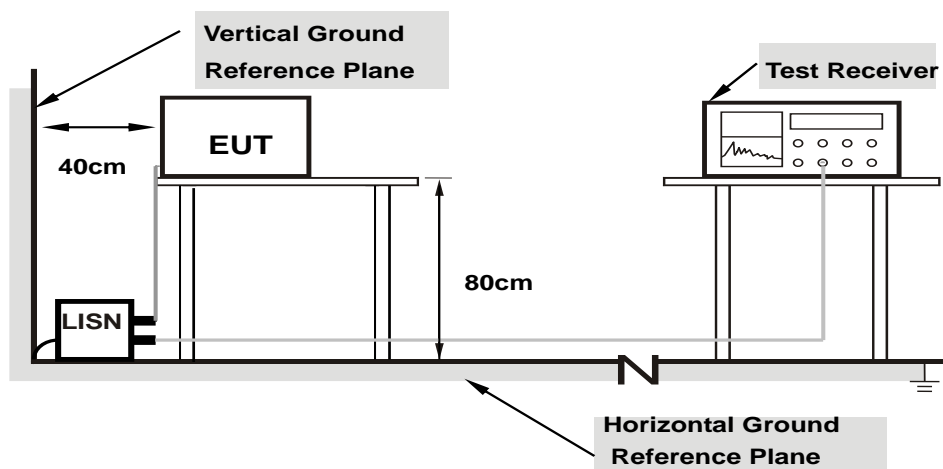

**Note: 1.Support units were connected to second LISN.**

For the actual test configuration, please refer to the attached file (Test Setup Photo).

### 6.7.2 Test Procedure

- The EUT was placed on a 0.8 meter to the top of table and placed 0.4 meters from the conducting wall of the shielded room with EUT being connected to the power mains through a line impedance stabilization network (LISN). Other support units were connected to the power mains through another LISN. The two LISNs provide 50 ohm/ 50 uH of coupling impedance for the measuring instrument.
- Both lines of the power mains connected to the EUT were checked for maximum conducted interference.
- The frequency range from 150 kHz to 30 MHz was searched. Emission levels under (Limit – 20 dB) was not recorded.

Note: The resolution bandwidth and video bandwidth of test receiver is 9 kHz for quasi-peak detection (QP) and average detection (AV) at frequency 0.15 MHz-30 MHz.



## 6.8 Unwanted Emissions below 1 GHz

### 6.8.1 Test Setup

#### For Radiated emission below 30 MHz

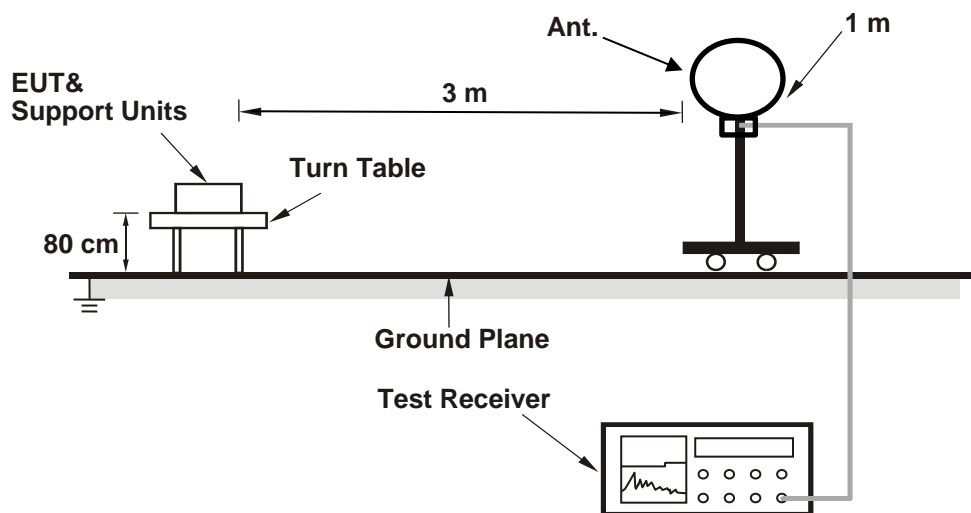

#### For Radiated emission above 30 MHz

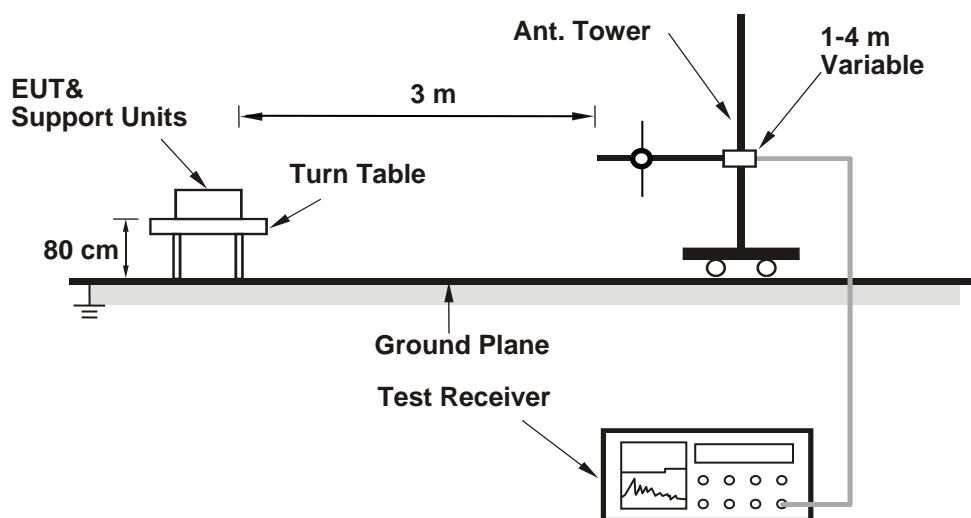

For the actual test configuration, please refer to the attached file (Test Setup Photo).

## 6.8.2 Test Procedure

### For Radiated emission below 30 MHz

- a. The EUT was placed on the top of a rotating table 0.8 meters above the ground at 3 meter chamber room for test. The table was rotated 360 degrees to determine the position of the highest radiation.
- b. The EUT was set 3 meters away from the interference-receiving antenna, which was mounted on the top of a variable-height antenna tower.
- c. Parallel, perpendicular, and ground-parallel orientations of the antenna are set to make the measurement.
- d. For each suspected emission, the EUT was arranged to its worst case and the rotatable table was turned from 0 degrees to 360 degrees to find the maximum reading.
- e. The test-receiver system was set to Quasi-Peak Detect Function and Specified Bandwidth with Maximum Hold Mode, except for the frequency band (9 kHz to 90 kHz and 110 kHz to 490 kHz) set to average detect function and peak detect function.

#### Notes:

1. The resolution bandwidth and video bandwidth of test receiver/spectrum analyzer is 200 Hz at frequency below 150 kHz.
2. The resolution bandwidth and video bandwidth of test receiver/spectrum analyzer is 9 kHz or 10 kHz at frequency (150 kHz to 30 MHz).
3. All modes of operation were investigated and the worst-case emissions are reported.

### For Radiated emission above 30 MHz

- a. The EUT was placed on the top of a rotating table 0.8 meters above the ground at 3 meter chamber room for test. The table was rotated 360 degrees to determine the position of the highest radiation.
- b. The EUT was set 3 meters away from the interference-receiving antenna, which was mounted on the top of a variable-height antenna tower.
- c. The height of antenna is varied from one meter to four meters above the ground to determine the maximum value of the field strength. Both horizontal and vertical polarizations of the antenna are set to make the measurement.
- d. For each suspected emission, the EUT was arranged to its worst case and then the antenna was tuned to heights from 1 meter to 4 meters and the rotatable table was turned from 0 degrees to 360 degrees to find the maximum reading.
- e. The test-receiver system was set to quasi-peak detect function and specified bandwidth with maximum hold mode when the test frequency is below 1 GHz.

#### Notes:

1. The resolution bandwidth and video bandwidth of test receiver/spectrum analyzer is 120 kHz for Quasi-peak detection (QP) at frequency below 1 GHz.
2. All modes of operation were investigated and the worst-case emissions are reported.

## 6.9 Unwanted Emissions above 1 GHz

### 6.9.1 Test Setup

#### For Radiated emission above 1 GHz

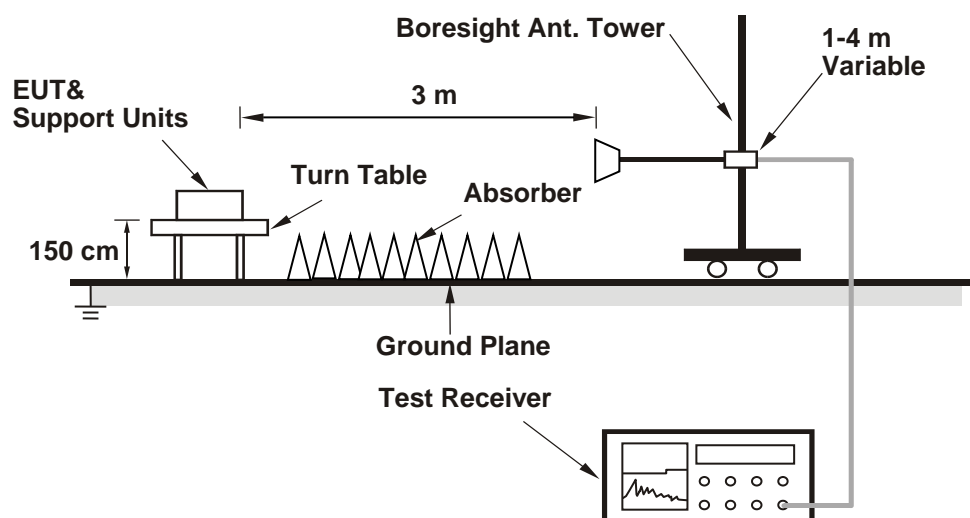

For the actual test configuration, please refer to the attached file (Test Setup Photo).

### 6.9.2 Test Procedure

- The EUT was placed on the top of a rotating table 1.5 meters above the ground at 3 meter chamber room for test. The table was rotated 360 degrees to determine the position of the highest radiation.
- The EUT was set 3 meters away from the interference-receiving antenna, which was mounted on the top of a variable-height antenna tower.
- The height of antenna is varied from one meter to four meters above the ground to determine the maximum value of the field strength. Both horizontal and vertical polarizations of the antenna are set to make the measurement.
- For each suspected emission, the EUT was arranged to its worst case and then the antenna was tuned to heights from 1 meter to 4 meters and the rotatable table was turned from 0 degrees to 360 degrees to find the maximum reading.
- The test-receiver system was set to peak and average detects function and specified bandwidth with maximum hold mode when the test frequency is above 1 GHz. If the peak reading value also meets average limit, measurement with the average detector is unnecessary.

#### Notes:

- The resolution bandwidth of test receiver/spectrum analyzer is 1 MHz and the video bandwidth is 3 MHz for Peak detection (PK) and Average detection (AV) at frequency above 1 GHz.
- According to ANSI C63.10 section 6.6.4 and 4.1.4.2.2. For fundamental and harmonic signal measurement, according to ANSI C63.10 section 7.5, the average value = peak value + duty cycle correction factor. For duty cycle correction factor values, see the Test Signal Duty Cycle section in this report.
- All modes of operation were investigated and the worst-case emissions are reported.

## 7 Test Results of Test Item

### 7.1 RF Output Power

#### Mode E

Input Power:	3.3 Vdc	Environmental Conditions:	24°C, 64% RH	Tested By:	John Peng
--------------	---------	---------------------------	--------------	------------	-----------

#### For Peak Power

##### GFSK

Chan.	Chan. Freq. (MHz)	Peak Power (mW)	Peak Power (dBm)	Power Limit (dBm)	Test Result
0	2402	3.99	6.01	21	Pass
39	2441	4.13	6.16	21	Pass
78	2480	4.064	6.09	21	Pass

Note: The antenna gain is 3.5 dBi < 6 dBi, so the output power limit shall not be reduced.

##### 8DPSK

Chan.	Chan. Freq. (MHz)	Peak Power (mW)	Peak Power (dBm)	Power Limit (dBm)	Test Result
0	2402	7.516	8.76	21	Pass
39	2441	8.11	9.09	21	Pass
78	2480	7.962	9.01	21	Pass

Note: The antenna gain is 3.5 dBi < 6 dBi, so the output power limit shall not be reduced.

#### For Average Power

##### GFSK

Chan.	Chan. Freq. (MHz)	Average Power (mW)	Average Power (dBm)
0	2402	3.793	5.79
39	2441	3.908	5.92
78	2480	3.873	5.88

##### 8DPSK

Chan.	Chan. Freq. (MHz)	Average Power (mW)	Average Power (dBm)
0	2402	3.516	5.46
39	2441	3.828	5.83
78	2480	3.776	5.77

## Mode F

Input Power:	3.3 Vdc	Environmental Conditions:	24°C, 64% RH	Tested By:	John Peng
--------------	---------	---------------------------	--------------	------------	-----------

## For Peak Power

### GFSK

Chan.	Chan. Freq. (MHz)	Peak Power (mW)	Peak Power (dBm)	Power Limit (dBm)	Test Result
0	2402	17.824	12.51	21	Pass
39	2441	18.197	12.60	21	Pass
78	2480	17.378	12.40	21	Pass

Note: The antenna gain is 3.5 dBi < 6 dBi, so the output power limit shall not be reduced.

### 8DPSK

Chan.	Chan. Freq. (MHz)	Peak Power (mW)	Peak Power (dBm)	Power Limit (dBm)	Test Result
0	2402	17.022	12.31	21	Pass
39	2441	17.498	12.43	21	Pass
78	2480	17.906	12.53	21	Pass

Note: The antenna gain is 3.5 dBi < 6 dBi, so the output power limit shall not be reduced.

## For Average Power

### GFSK

Chan.	Chan. Freq. (MHz)	Average Power (mW)	Average Power (dBm)
0	2402	17.179	12.35
39	2441	17.539	12.44
78	2480	16.672	12.22

### 8DPSK

Chan.	Chan. Freq. (MHz)	Average Power (mW)	Average Power (dBm)
0	2402	9.036	9.56
39	2441	9.226	9.65
78	2480	9.572	9.81

## 7.2 Number of Hopping Frequency Used

### Mode E

Input Power:	3.3 Vdc	Environmental Conditions:	24°C, 64% RH	Tested By:	John Peng
--------------	---------	---------------------------	--------------	------------	-----------

### GFSK

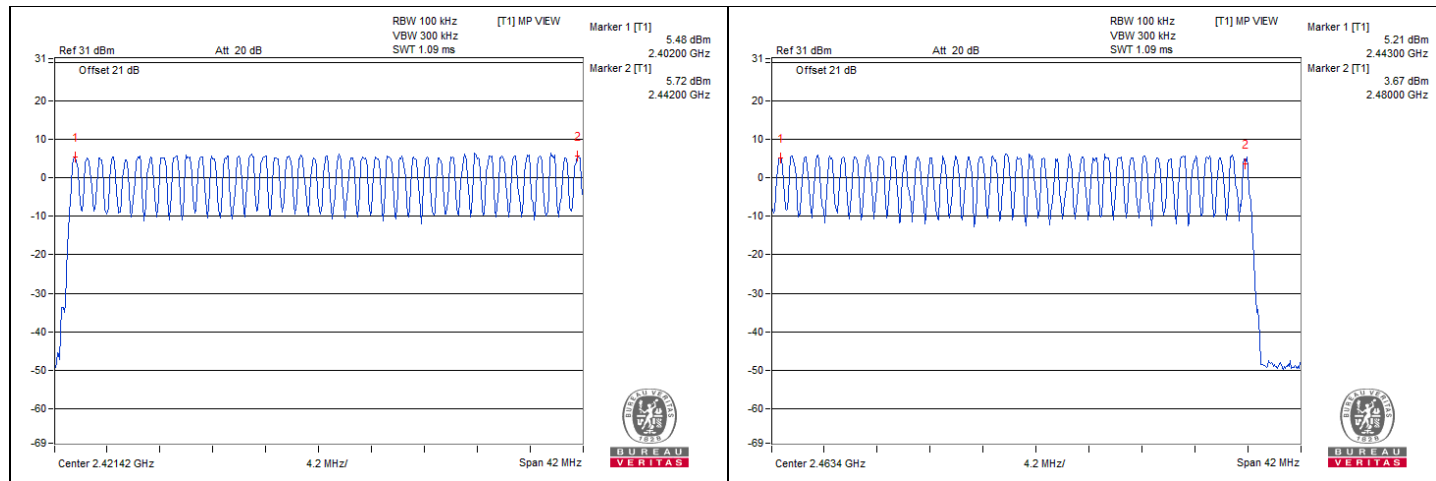

Note: There are 79 hopping frequencies in the hopping mode. On the plots, it shows that the hopping frequencies are equally spaced.

### 8DPSK

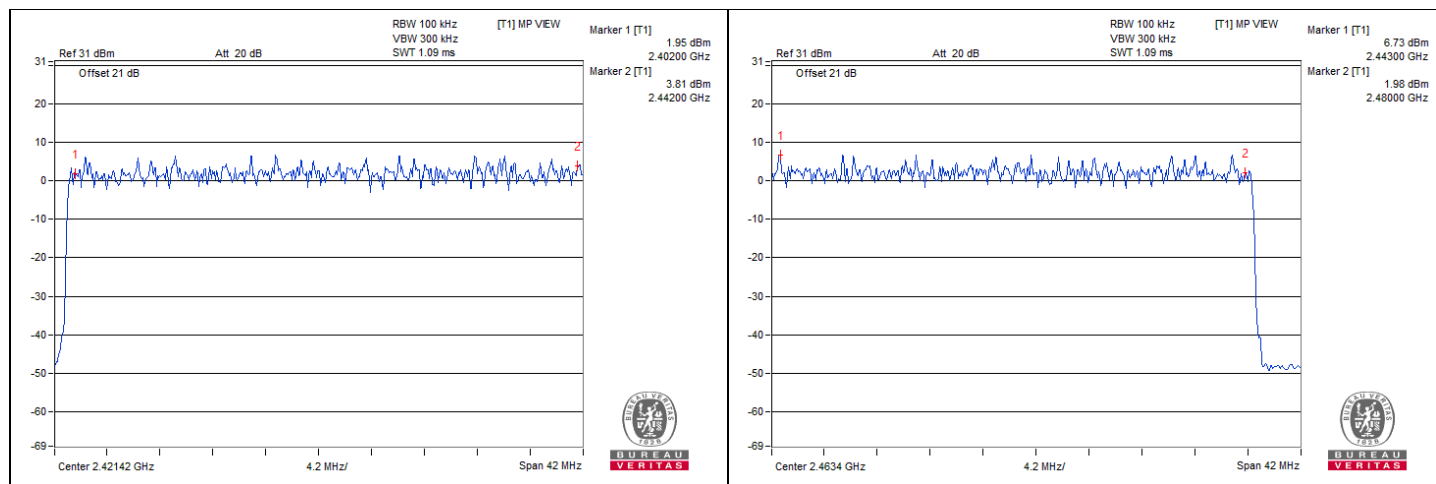

Note: There are 79 hopping frequencies in the hopping mode. On the plots, it shows that the hopping frequencies are equally spaced.

## Mode F

Input Power:	3.3 Vdc	Environmental Conditions:	24°C, 64% RH	Tested By:	John Peng
--------------	---------	---------------------------	--------------	------------	-----------

### GFSK

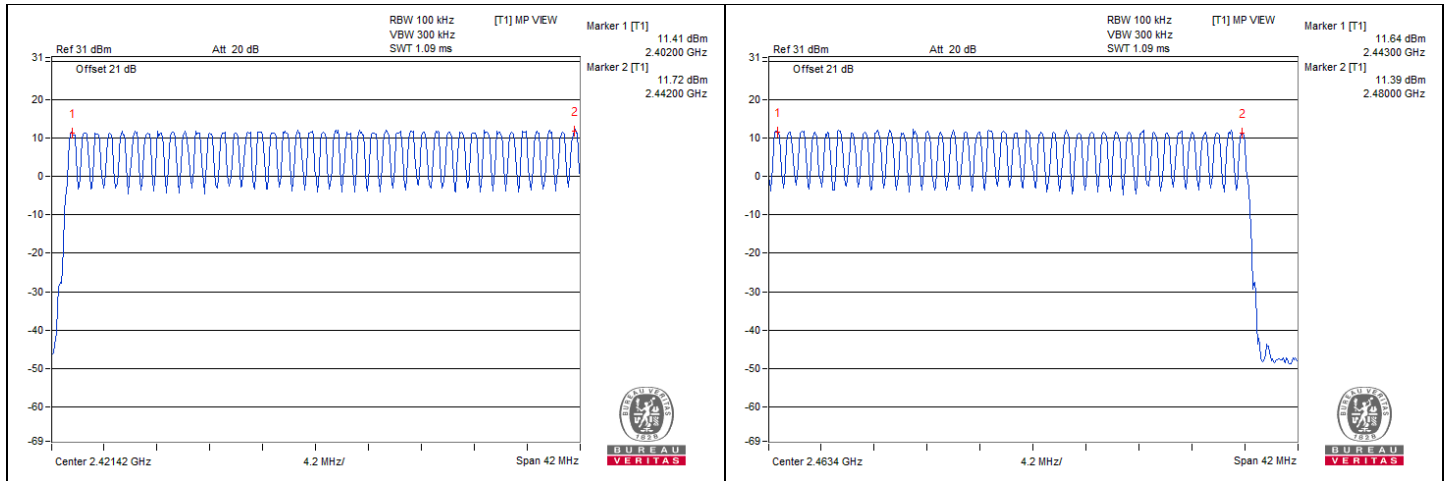

Note: There are 79 hopping frequencies in the hopping mode. On the plots, it shows that the hopping frequencies are equally spaced.

### 8DPSK

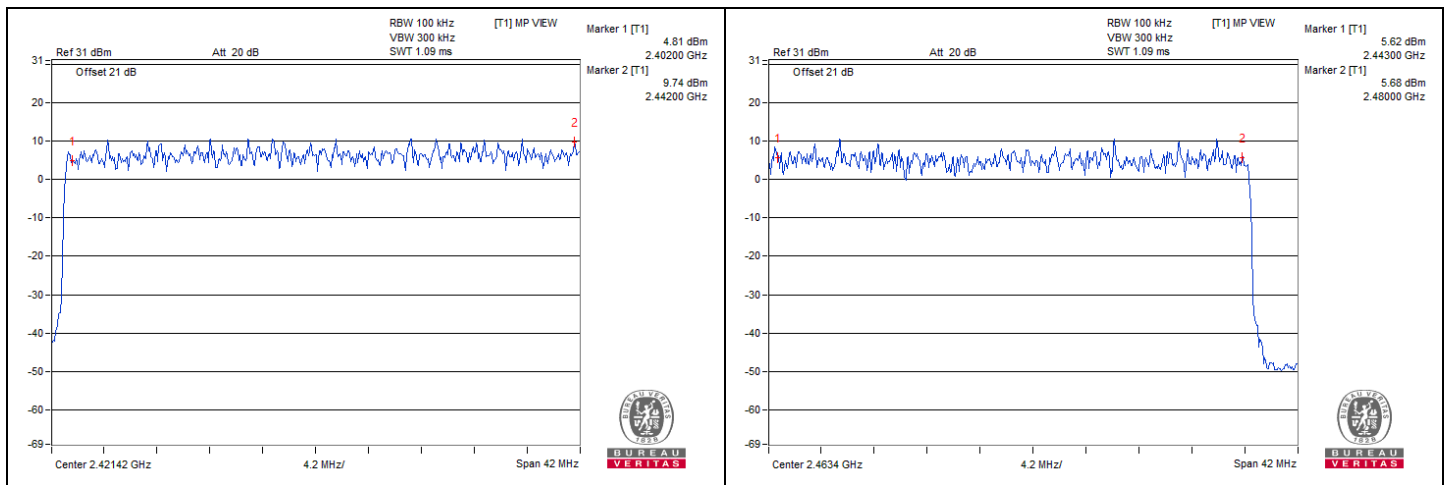

Note: There are 79 hopping frequencies in the hopping mode. On the plots, it shows that the hopping frequencies are equally spaced.



### 7.3 Dwell Time on Each Channel

#### Mode E

Input Power:	3.3 Vdc	Environmental Conditions:	24°C, 64% RH	Tested By:	John Peng
--------------	---------	---------------------------	--------------	------------	-----------

#### GFSK

Mode	Number of transmission in 31.6 sec	Length of transmission time (msec)	Result (msec)	Limit (msec)	Test Result
DH1	50 (times / 5 sec) * 6.32 = 316 times	0.438	138.41	400	Pass
DH3	26 (times / 5 sec) * 6.32 = 165 times	1.71	282.15	400	Pass
DH5	17 (times / 5 sec) * 6.32 = 108 times	2.96	319.68	400	Pass

#### Spectrum plots of Dwell Time

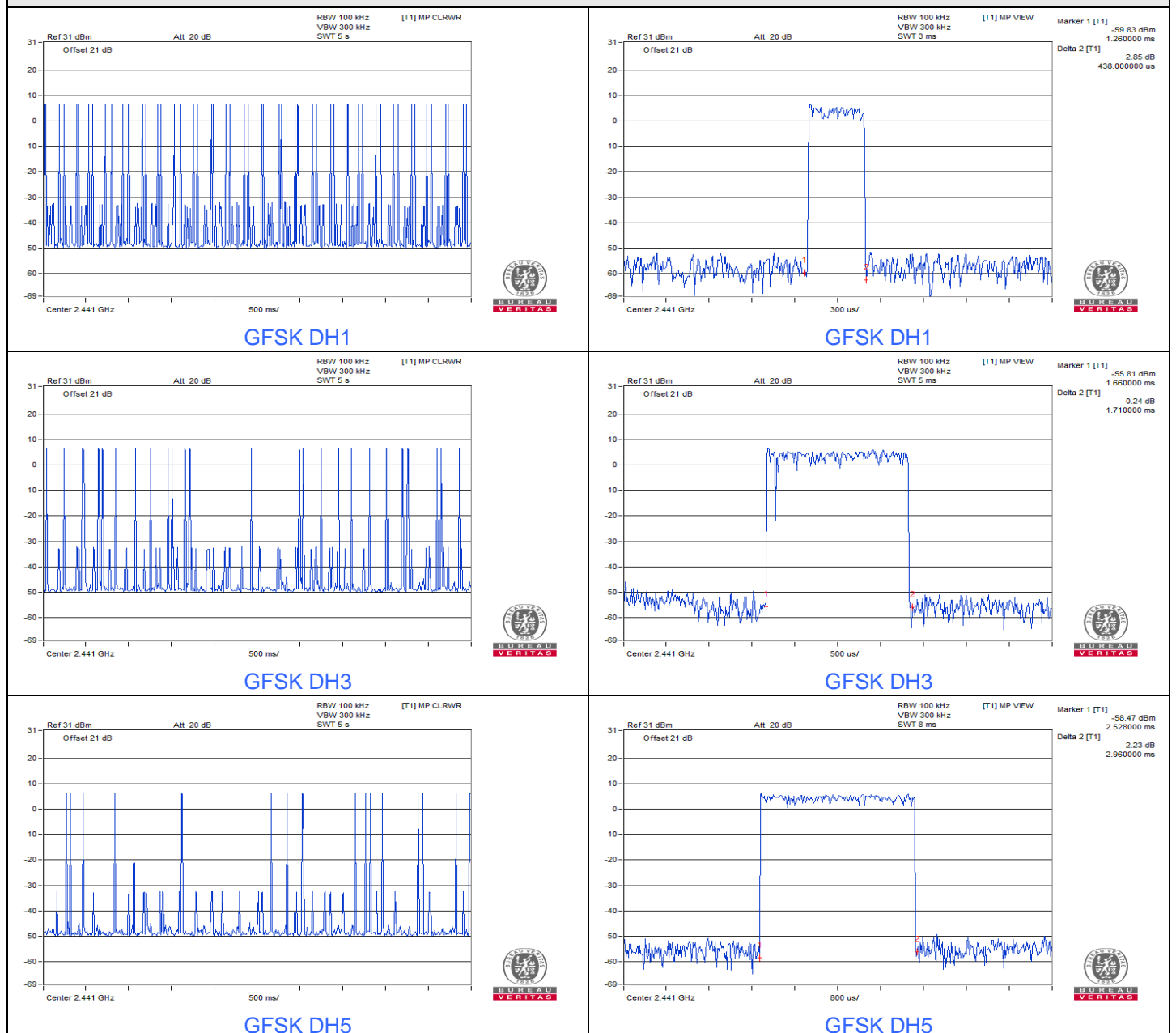



8DPSK

Mode	Number of transmission in 31.6 sec	Length of transmission time (msec)	Result (msec)	Limit (msec)	Test Result
3DH1	50 (times / 5 sec) * 6.32 = 316 times	0.42	132.72	400	Pass
3DH3	27 (times / 5 sec) * 6.32 = 171 times	1.68	287.28	400	Pass
3DH5	17 (times / 5 sec) * 6.32 = 108 times	2.944	317.95	400	Pass

Spectrum plots of Dwell Time

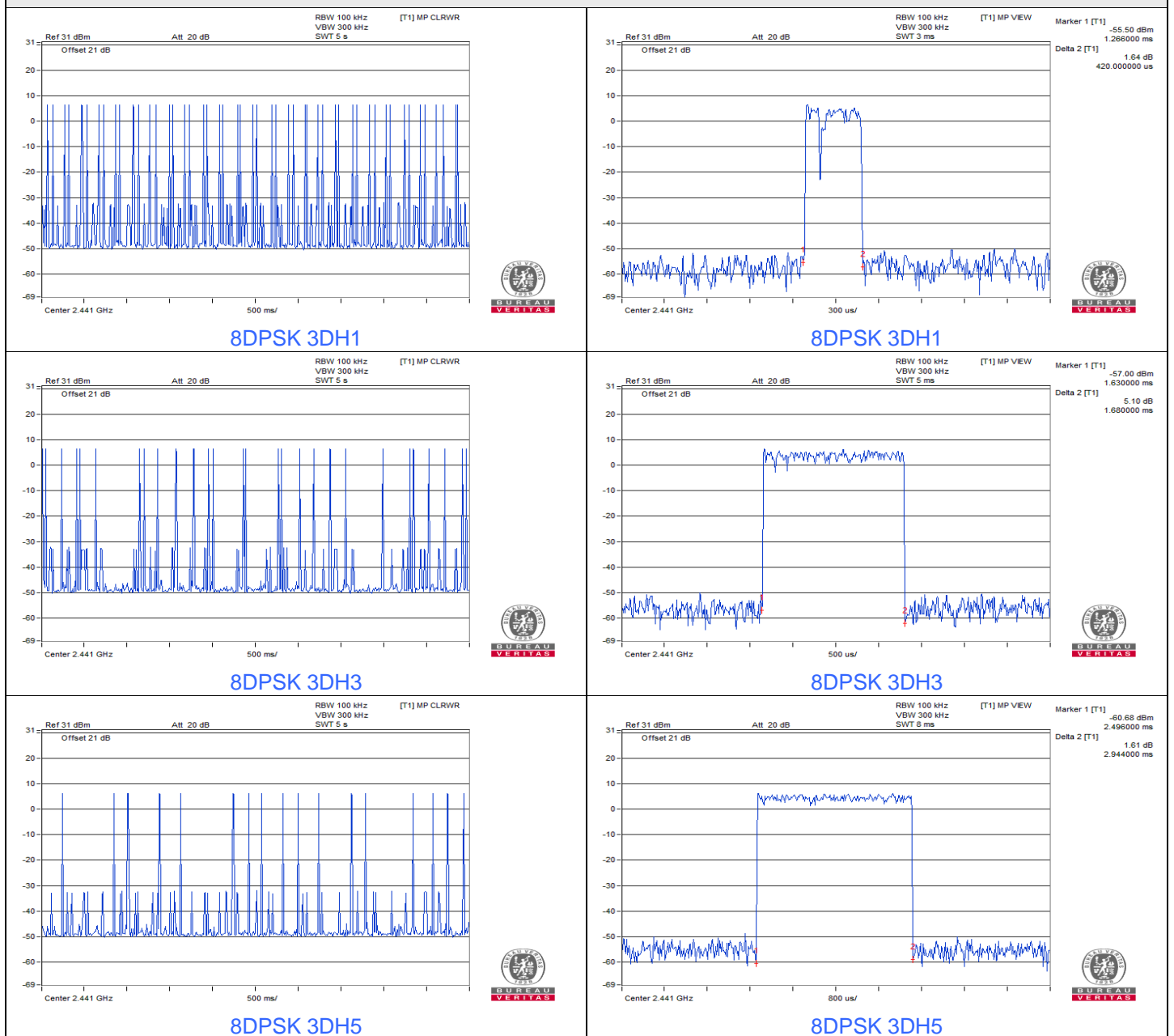



Mode F

Input Power:	3.3 Vdc	Environmental Conditions:	24°C, 64% RH	Tested By:	John Peng
--------------	---------	---------------------------	--------------	------------	-----------

GFSK

Mode	Number of transmission in 31.6 sec	Length of transmission time (msec)	Result (msec)	Limit (msec)	Test Result
DH1	51 (times / 5 sec) * 6.32 = 323 times	0.42	135.66	400	Pass
DH3	25 (times / 5 sec) * 6.32 = 158 times	1.68	265.44	400	Pass
DH5	17 (times / 5 sec) * 6.32 = 108 times	3.008	324.86	400	Pass

Spectrum plots of Dwell Time



8DPSK

Mode	Number of transmission in 31.6 sec	Length of transmission time (msec)	Result (msec)	Limit (msec)	Test Result
3DH1	50 (times / 5 sec) * 6.32 = 316 times	0.45	142.2	400	Pass
3DH3	27 (times / 5 sec) * 6.32 = 171 times	1.7	290.7	400	Pass
3DH5	17 (times / 5 sec) * 6.32 = 108 times	2.944	317.95	400	Pass

Spectrum plots of Dwell Time



## 7.4 Hopping Channel Separation

### Mode E

Input Power:	3.3 Vdc	Environmental Conditions:	24°C, 64% RH	Tested By:	John Peng
--------------	---------	---------------------------	--------------	------------	-----------

### GFSK

Channel	Frequency (MHz)	Hopping Channel Separation (MHz)	Minimum Limit (MHz)	Test Result
0	2402	1	0.64	Pass
39	2441	1	0.64	Pass
78	2480	1	0.64	Pass

Note: The minimum limit is two-third 20dB bandwidth.

### 8DPSK

Channel	Frequency (MHz)	Hopping Channel Separation (MHz)	Minimum Limit (MHz)	Test Result
0	2402	1	0.86	Pass
39	2441	1	0.86	Pass
78	2480	1	0.87	Pass

Note: The minimum limit is two-third 20dB bandwidth.

Spectrum Plot of Minimum Value

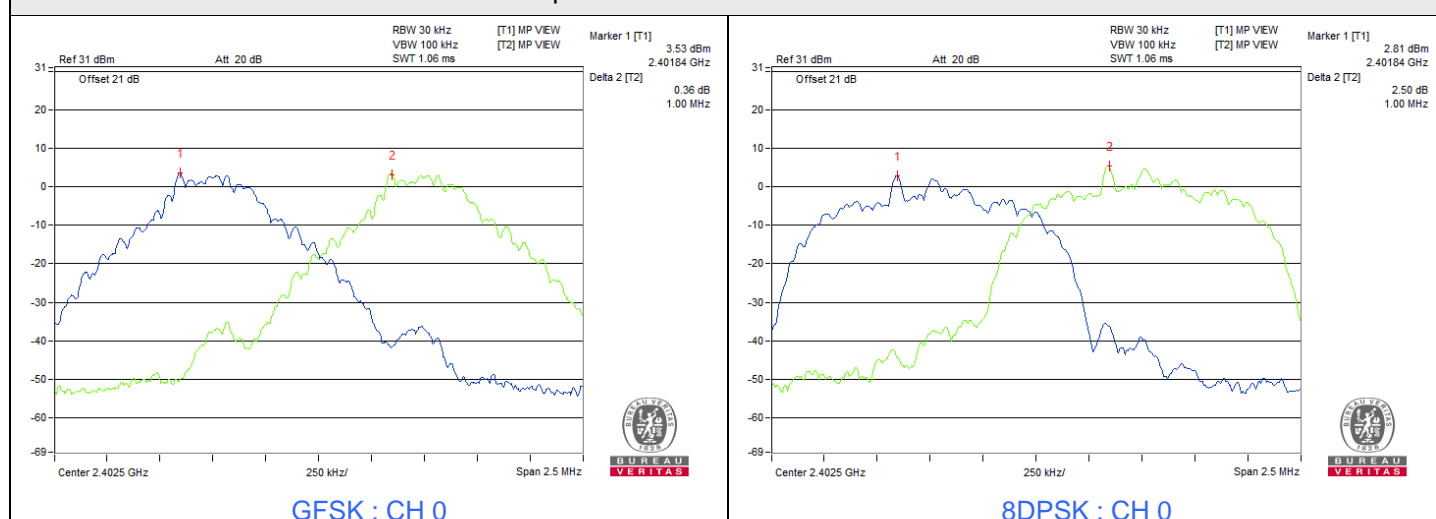

**Mode F**

Input Power:	3.3 Vdc	Environmental Conditions:	24°C, 64% RH	Tested By:	John Peng
--------------	---------	---------------------------	--------------	------------	-----------

**GFSK**

Channel	Frequency (MHz)	Hopping Channel Separation (MHz)	Minimum Limit (MHz)	Test Result
0	2402	1	0.64	Pass
39	2441	1	0.64	Pass
78	2480	1	0.64	Pass

Note: The minimum limit is two-third 20dB bandwidth.

**8DPSK**

Channel	Frequency (MHz)	Hopping Channel Separation (MHz)	Minimum Limit (MHz)	Test Result
0	2402	1	0.87	Pass
39	2441	1	0.86	Pass
78	2480	1	0.87	Pass

Note: The minimum limit is two-third 20dB bandwidth.

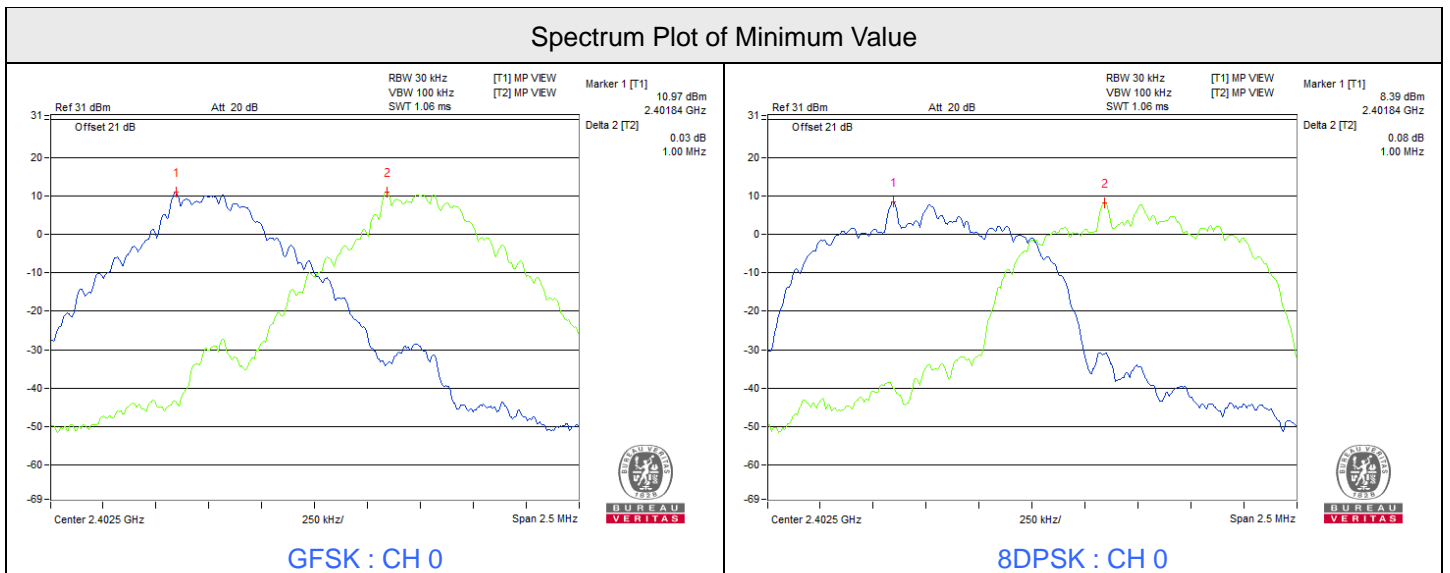

## 7.5 20 dB Bandwidth

### Mode E

Input Power:	3.3 Vdc	Environmental Conditions:	24°C, 64% RH	Tested By:	John Peng
--------------	---------	---------------------------	--------------	------------	-----------

### GFSK

Channel	Frequency (MHz)	20dB Bandwidth (MHz)
0	2402	0.96
39	2441	0.96
78	2480	0.96

### 8DPSK

Channel	Frequency (MHz)	20dB Bandwidth (MHz)
0	2402	1.29
39	2441	1.28
78	2480	1.3

Spectrum Plot of Maximum Value

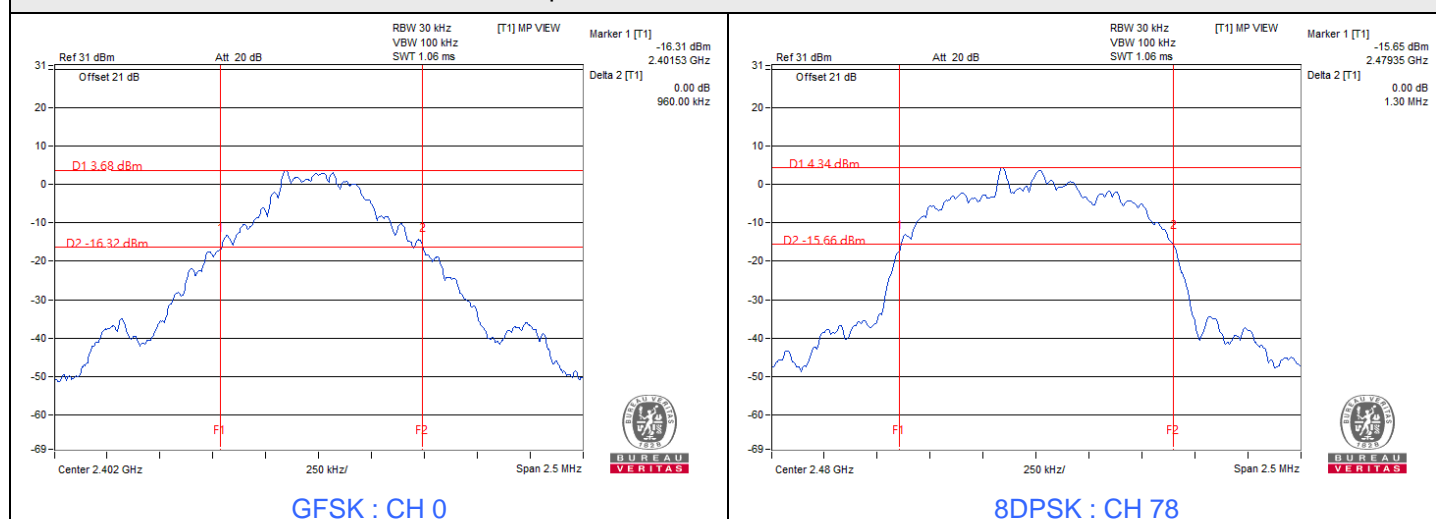

**Mode F**

Input Power:	3.3 Vdc	Environmental Conditions:	24°C, 64% RH	Tested By:	John Peng
--------------	---------	---------------------------	--------------	------------	-----------

**GFSK**

Channel	Frequency (MHz)	20dB Bandwidth (MHz)
0	2402	0.96
39	2441	0.96
78	2480	0.96

**8DPSK**

Channel	Frequency (MHz)	20dB Bandwidth (MHz)
0	2402	1.3
39	2441	1.28
78	2480	1.3

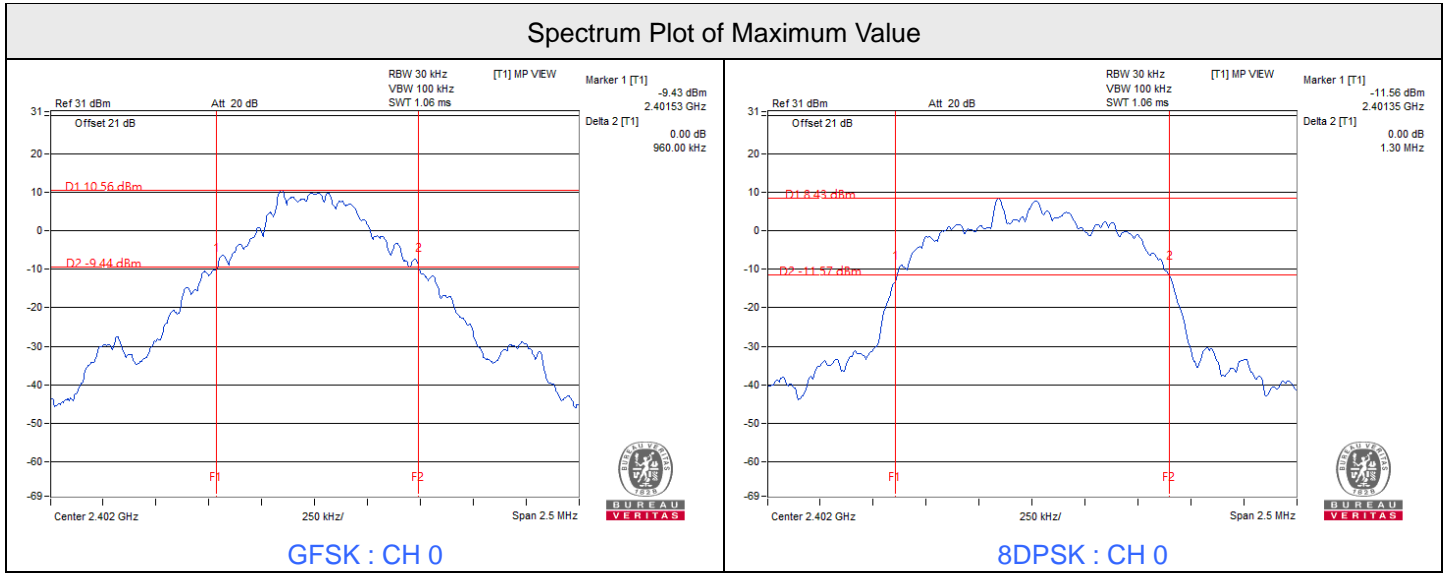



BUREAU VERITAS

## 7.6 Conducted Out of Band Emissions

### Mode E

Input Power:	3.3 Vdc	Environmental Conditions:	24°C, 64% RH	Tested By:	John Peng
--------------	---------	---------------------------	--------------	------------	-----------

### GFSK

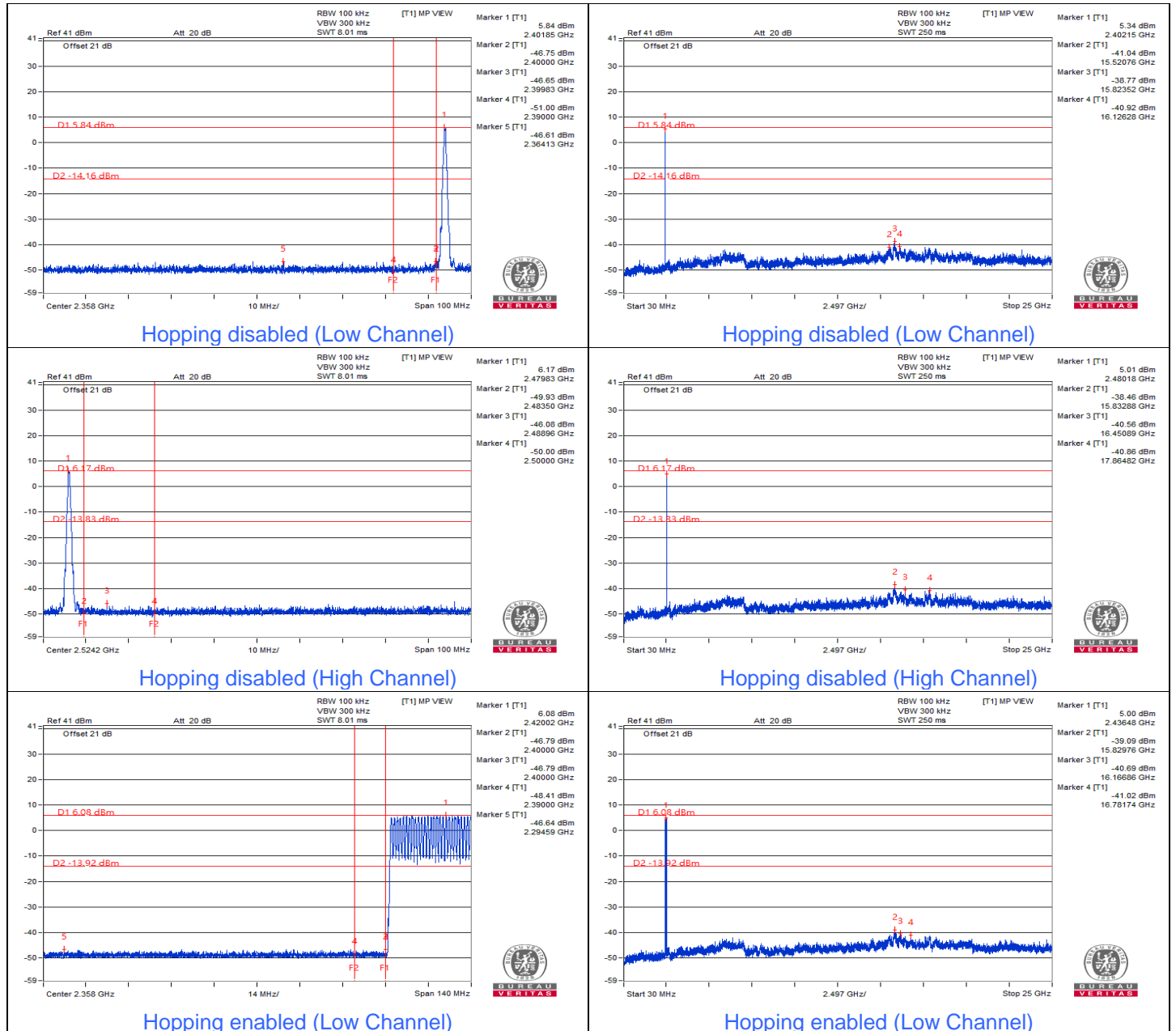



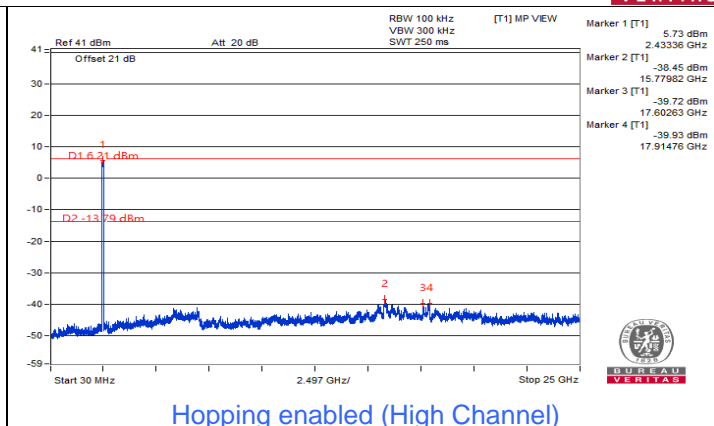
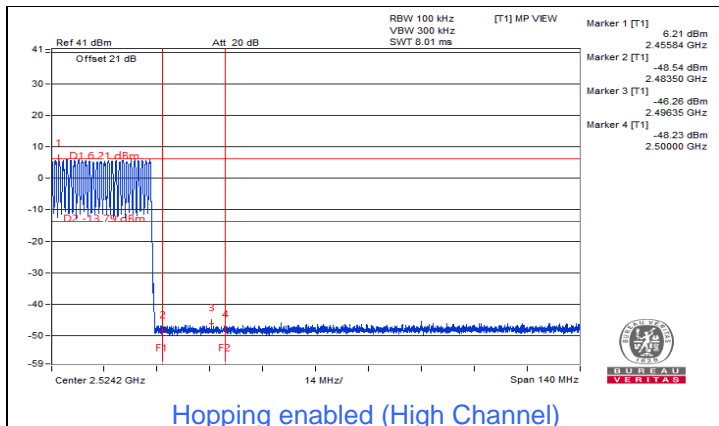



# 8DPSK

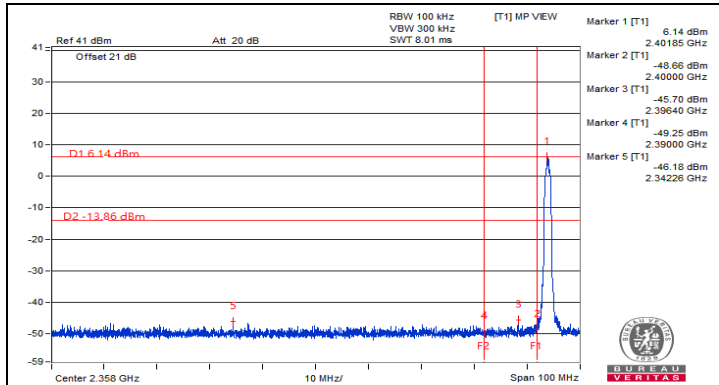

Hopping disabled (Low Channel)

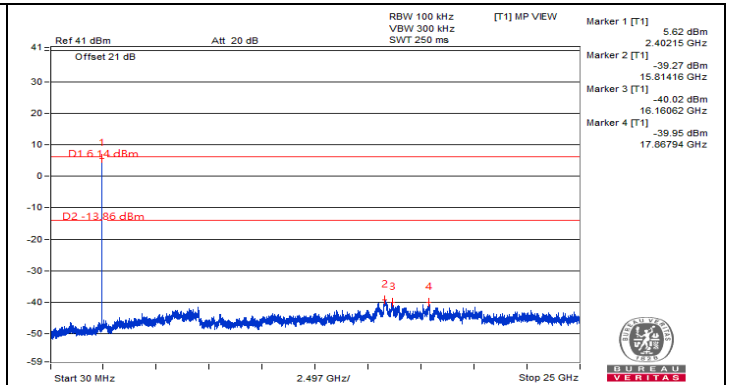

Hopping disabled (Low Channel)

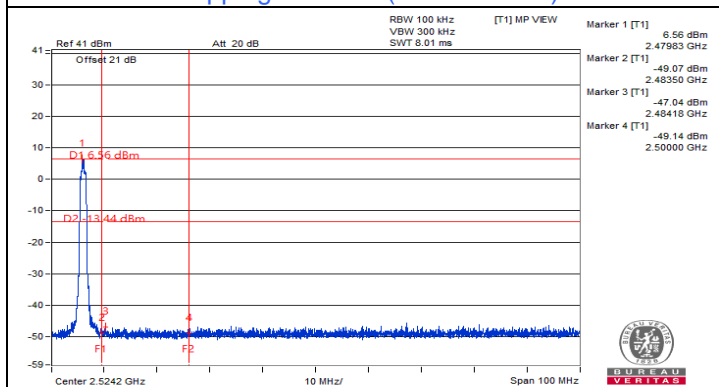

Hopping disabled (High Channel)

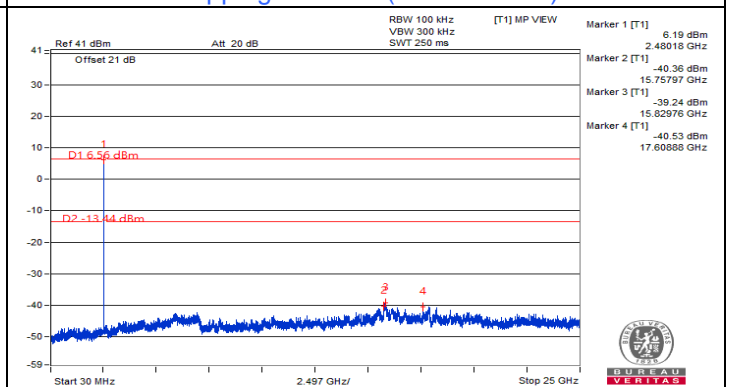

Hopping disabled (High Channel)

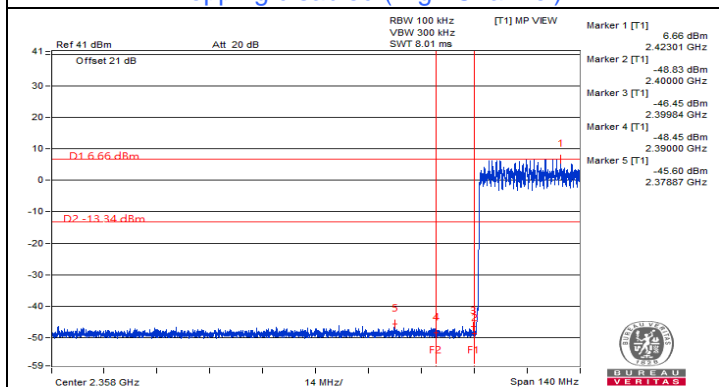

Hopping enabled (Low Channel)

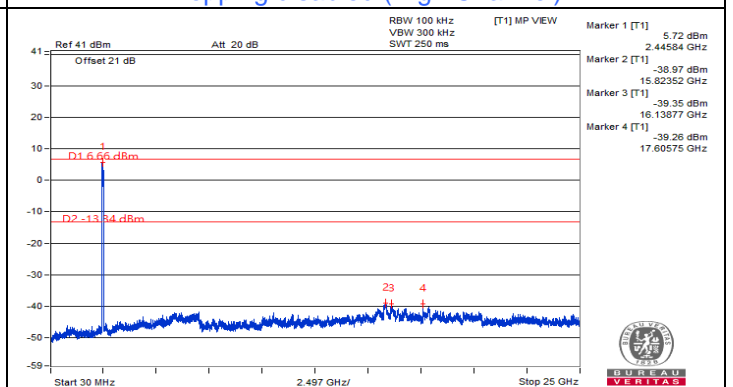

Hopping enabled (Low Channel)

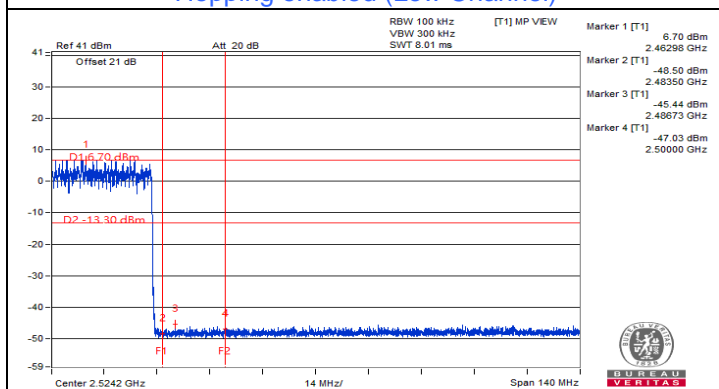

Hopping enabled (High Channel)

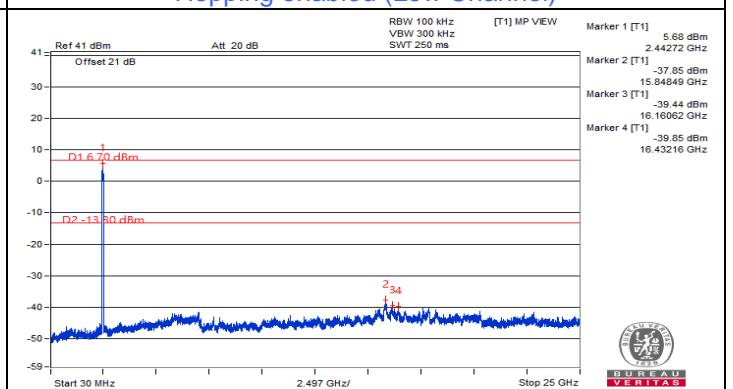

Hopping enabled (High Channel)



BUREAU VERITAS

# Mode F

Input Power:	3.3 Vdc	Environmental Conditions:	24°C, 64% RH	Tested By:	John Peng
--------------	---------	---------------------------	--------------	------------	-----------

## GFSK

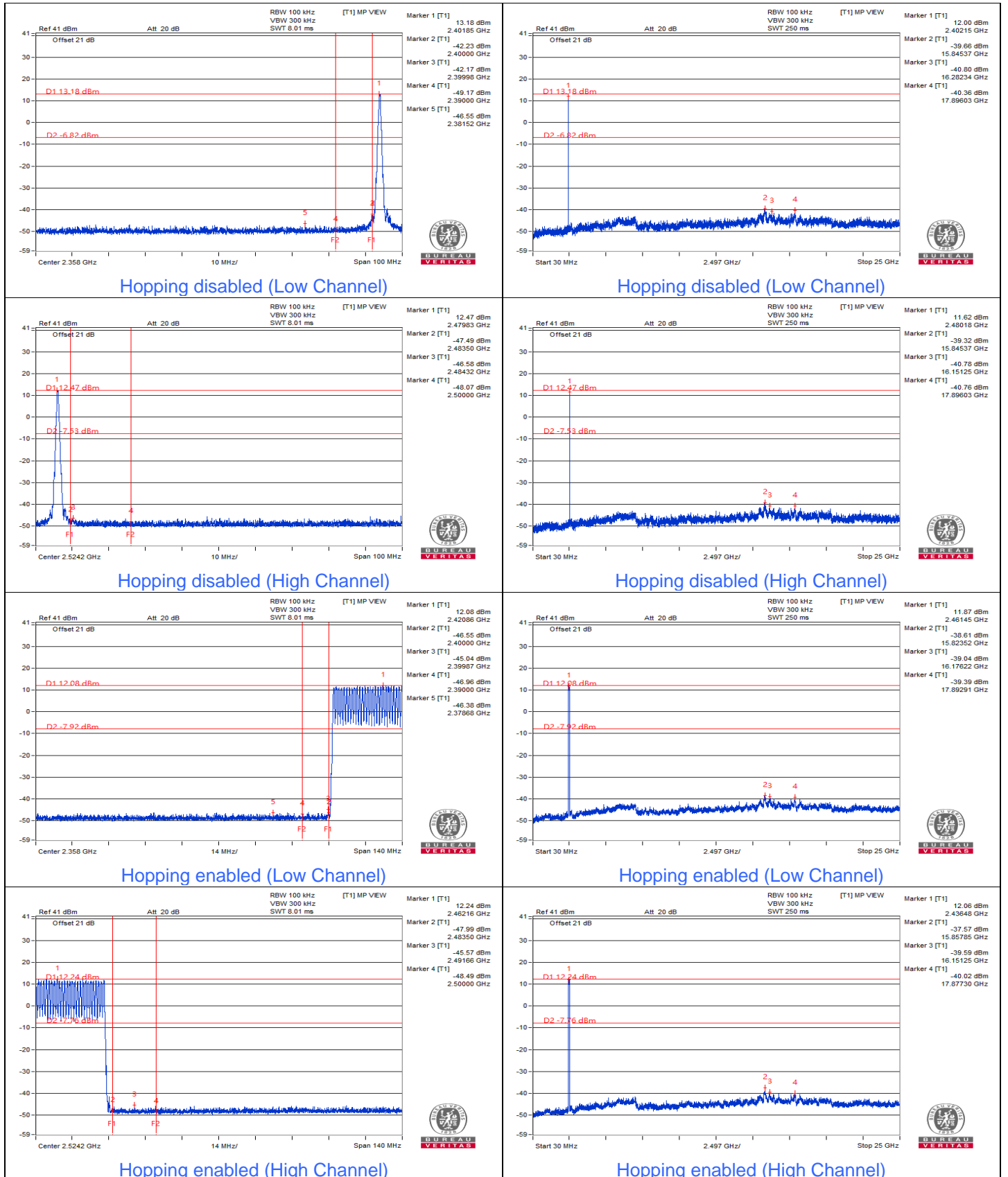



# 8DPSK

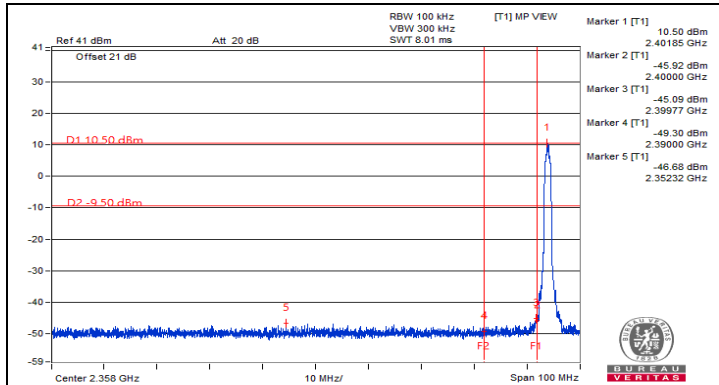

Hopping disabled (Low Channel)

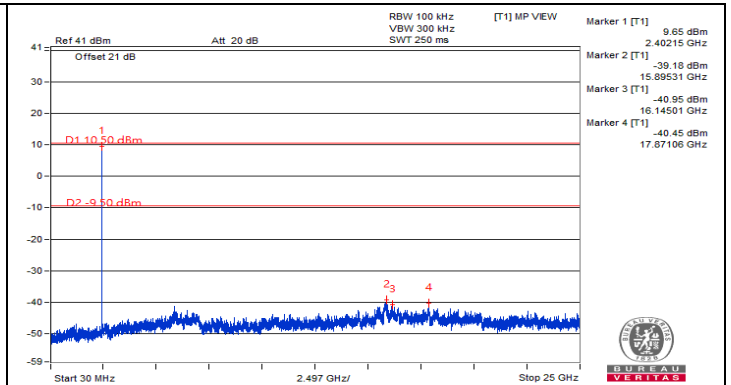

Hopping disabled (Low Channel)

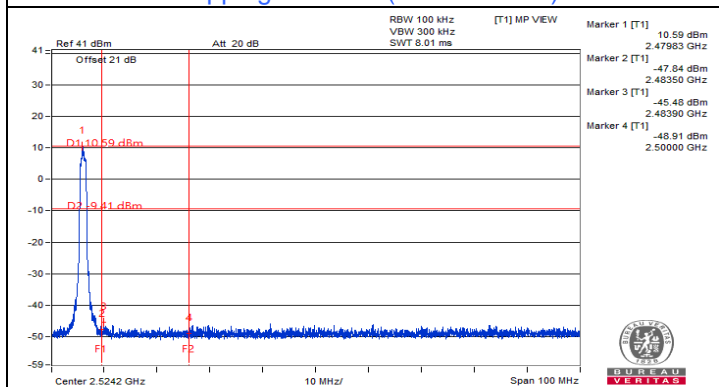

Hopping disabled (High Channel)

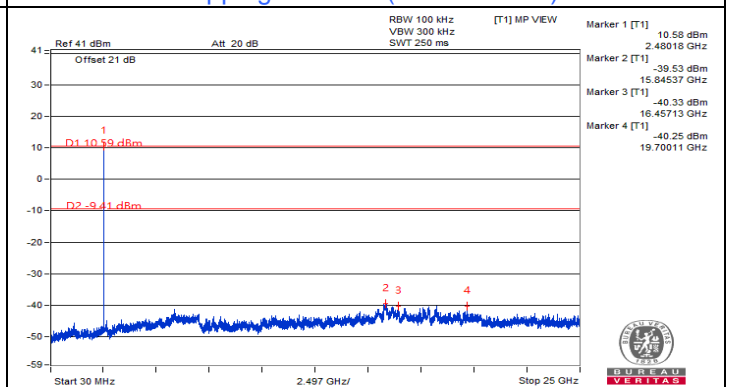

Hopping disabled (High Channel)

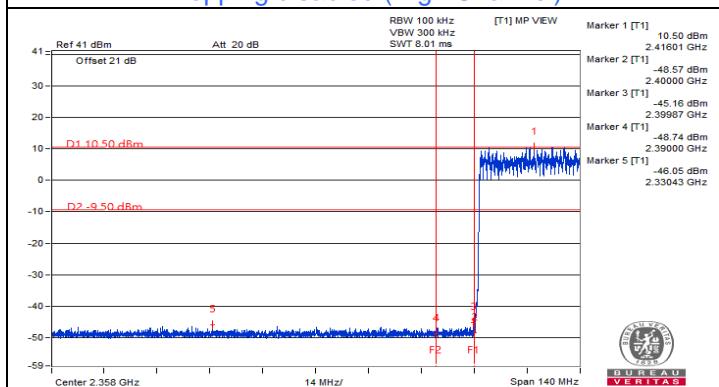

Hopping enabled (Low Channel)

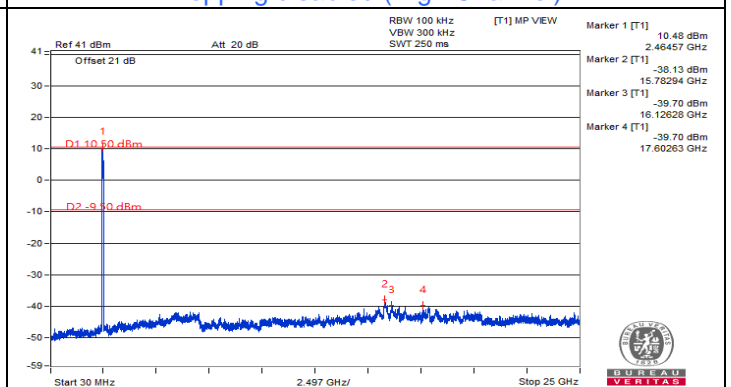

Hopping enabled (Low Channel)

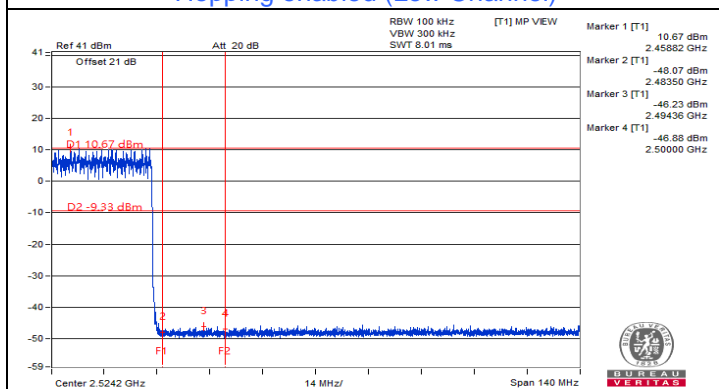

Hopping enabled (High Channel)

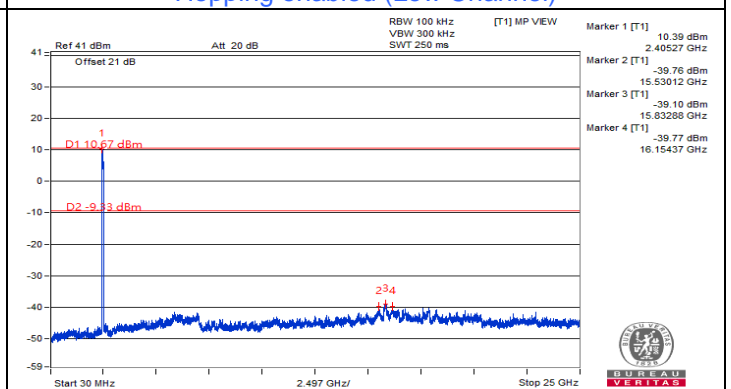

Hopping enabled (High Channel)

## 7.7 AC Power Conducted Emissions

### Mode C

RF Mode	TX BT GFSK	Channel	CH 39 : 2441 MHz
Frequency Range	150 kHz ~ 30 MHz	Detector Function & Resolution Bandwidth	Quasi-Peak (QP) / Average (AV), 9 kHz
Input Power (System)	120 Vac, 60Hz	Environmental Conditions	22°C, 64% RH
Tested By	Samposn Chen		

Phase Of Power : Line (L)										
No	Frequency (MHz)	Correction Factor (dB)	Reading Value (dBuV)		Emission Level (dBuV)		Limit (dBuV)		Margin (dB)	
			Q.P.	AV.	Q.P.	AV.	Q.P.	AV.	Q.P.	AV.
1	0.15000	10.05	40.01	23.56	50.06	33.61	66.00	56.00	-15.94	-22.39
2	0.20469	10.05	35.43	20.47	45.48	30.52	63.42	53.42	-17.94	-22.90
3	1.50391	10.14	17.88	11.23	28.02	21.37	56.00	46.00	-27.98	-24.63
4	14.63281	10.90	20.43	13.66	31.33	24.56	60.00	50.00	-28.67	-25.44
5	21.16797	11.24	24.70	23.46	35.94	34.70	60.00	50.00	-24.06	-15.30
6	25.87109	11.31	25.99	24.69	37.30	36.00	60.00	50.00	-22.70	-14.00

#### Remarks:

1. Q.P. and AV. are abbreviations of quasi-peak and average individually.
2. The emission levels of other frequencies were very low against the limit.
3. Margin value = Emission level – Limit value
4. Correction factor = Insertion loss + Cable loss
5. Emission Level = Correction Factor + Reading Value

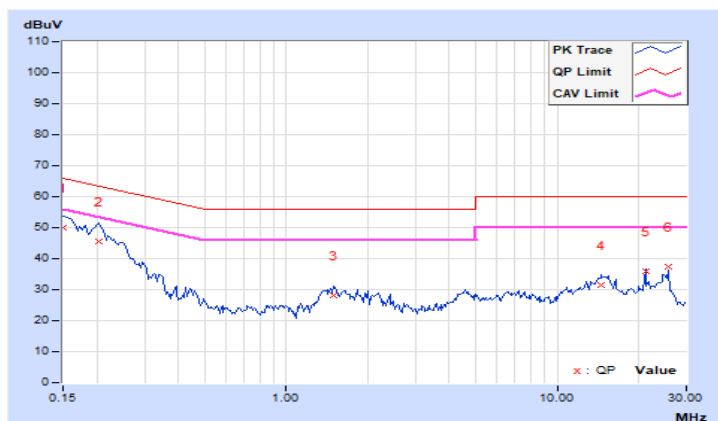

<b>RF Mode</b>	TX BT GFSK	<b>Channel</b>	CH 39 : 2441 MHz
<b>Frequency Range</b>	150 kHz ~ 30 MHz	<b>Detector Function &amp; Resolution Bandwidth</b>	Quasi-Peak (QP) / Average (AV), 9 kHz
<b>Input Power (System)</b>	120 Vac, 60Hz	<b>Environmental Conditions</b>	22°C, 64% RH
<b>Tested By</b>	Samposn Chen		

Phase Of Power : Neutral (N)										
No	Frequency (MHz)	Correction Factor (dB)	Reading Value (dBuV)		Emission Level (dBuV)		Limit (dBuV)		Margin (dB)	
			Q.P.	AV.	Q.P.	AV.	Q.P.	AV.	Q.P.	AV.
1	0.15391	10.02	40.64	23.94	50.66	33.96	65.79	55.79	-15.13	-21.83
2	0.20469	10.03	35.34	21.17	45.37	31.20	63.42	53.42	-18.05	-22.22
3	0.25156	10.03	30.20	15.38	40.23	25.41	61.71	51.71	-21.48	-26.30
4	1.50391	10.11	16.60	10.30	26.71	20.41	56.00	46.00	-29.29	-25.59
5	21.16797	10.96	24.78	24.14	35.74	35.10	60.00	50.00	-24.26	-14.90
<b>6</b>	<b>25.87500</b>	<b>10.98</b>	<b>26.42</b>	<b>25.74</b>	<b>37.40</b>	<b>36.72</b>	<b>60.00</b>	<b>50.00</b>	<b>-22.60</b>	<b>-13.28</b>

**Remarks:**

1. Q.P. and AV. are abbreviations of quasi-peak and average individually.
2. The emission levels of other frequencies were very low against the limit.
3. Margin value = Emission level – Limit value
4. Correction factor = Insertion loss + Cable loss
5. Emission Level = Correction Factor + Reading Value

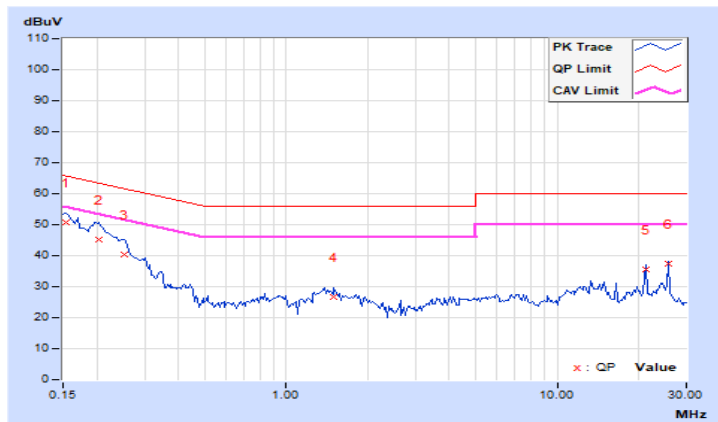

## Mode D

<b>RF Mode</b>	TX BT GFSK	<b>Channel</b>	CH 39 : 2441 MHz
<b>Frequency Range</b>	150 kHz ~ 30 MHz	<b>Detector Function &amp; Resolution Bandwidth</b>	Quasi-Peak (QP) / Average (AV), 9 kHz
<b>Input Power (System)</b>	120 Vac, 60Hz	<b>Environmental Conditions</b>	22°C, 64% RH
<b>Tested By</b>	Samposn Chen		

Phase Of Power : Line (L)										
No	Frequency (MHz)	Correction Factor (dB)	Reading Value (dBUV)		Emission Level (dBUV)		Limit (dBUV)		Margin (dB)	
			Q.P.	AV.	Q.P.	AV.	Q.P.	AV.	Q.P.	AV.
1	0.15391	10.05	40.30	24.06	50.35	34.11	65.79	55.79	-15.44	-21.68
2	0.20078	10.05	35.24	20.56	45.29	30.61	63.58	53.58	-18.29	-22.97
3	0.24766	10.05	30.32	14.96	40.37	25.01	61.84	51.84	-21.47	-26.83
4	4.42578	10.28	15.15	10.08	25.43	20.36	56.00	46.00	-30.57	-25.64
5	15.15234	10.93	19.52	13.50	30.45	24.43	60.00	50.00	-29.55	-25.57
6	25.87109	11.31	25.86	24.64	37.17	35.95	60.00	50.00	-22.83	-14.05

### Remarks:

1. Q.P. and AV. are abbreviations of quasi-peak and average individually.
2. The emission levels of other frequencies were very low against the limit.
3. Margin value = Emission level – Limit value
4. Correction factor = Insertion loss + Cable loss
5. Emission Level = Correction Factor + Reading Value

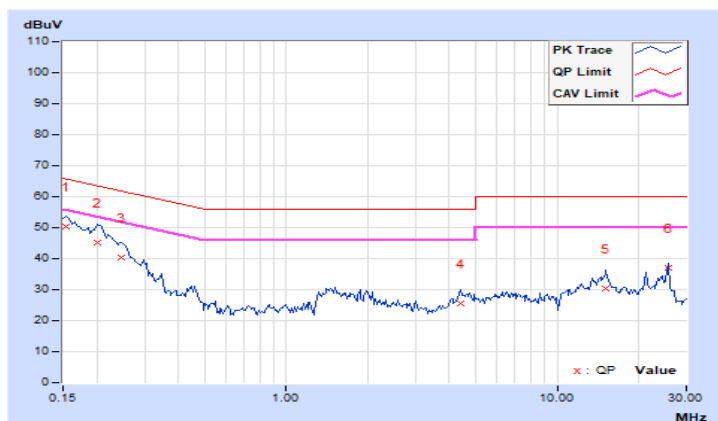

<b>RF Mode</b>	TX BT GFSK	<b>Channel</b>	CH 39 : 2441 MHz
<b>Frequency Range</b>	150 kHz ~ 30 MHz	<b>Detector Function &amp; Resolution Bandwidth</b>	Quasi-Peak (QP) / Average (AV), 9 kHz
<b>Input Power (System)</b>	120 Vac, 60Hz	<b>Environmental Conditions</b>	22°C, 64% RH
<b>Tested By</b>	Samposn Chen		

Phase Of Power : Neutral (N)										
No	Frequency (MHz)	Correction Factor (dB)	Reading Value (dBuV)		Emission Level (dBuV)		Limit (dBuV)		Margin (dB)	
			Q.P.	AV.	Q.P.	AV.	Q.P.	AV.	Q.P.	AV.
1	0.15000	10.02	39.93	23.54	49.95	33.56	66.00	56.00	-16.05	-22.44
2	0.20078	10.03	35.34	20.62	45.37	30.65	63.58	53.58	-18.21	-22.93
3	0.25156	10.03	30.30	15.30	40.33	25.33	61.71	51.71	-21.38	-26.38
4	1.99219	10.13	13.18	6.24	23.31	16.37	56.00	46.00	-32.69	-29.63
5	21.16797	10.96	24.58	24.02	35.54	34.98	60.00	50.00	-24.46	-15.02
6	25.87500	10.98	26.20	25.52	37.18	36.50	60.00	50.00	-22.82	-13.50

**Remarks:**

1. Q.P. and AV. are abbreviations of quasi-peak and average individually.
2. The emission levels of other frequencies were very low against the limit.
3. Margin value = Emission level – Limit value
4. Correction factor = Insertion loss + Cable loss
5. Emission Level = Correction Factor + Reading Value

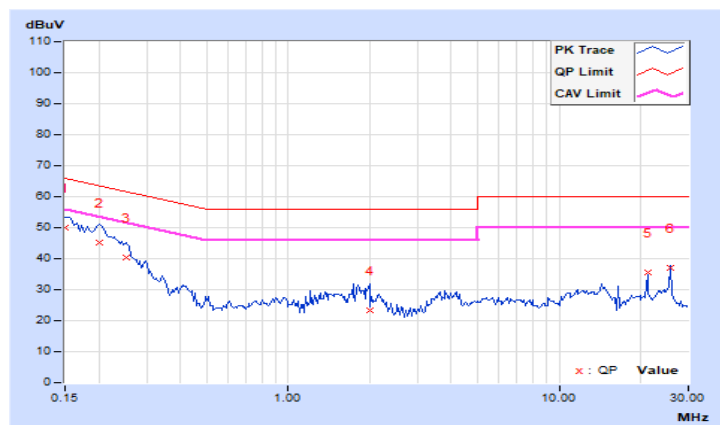



## 7.8 Unwanted Emissions below 1 GHz

### Mode A

RF Mode	TX BT GFSK	Channel	CH 39 : 2441 MHz
Frequency Range	9 kHz ~ 1 GHz	Detector Function & Bandwidth	(QP) RB = 120kHz
Input Power (System)	120 Vac, 60Hz	Environmental Conditions	19°C, 64% RH
Tested By	Sampson Chen		

#### Antenna Polarity & Test Distance : Horizontal at 3 m

No	Frequency (MHz)	Emission Level (dBUV/m)	Limit (dBUV/m)	Margin (dB)	Antenna Height (m)	Table Angle (Degree)	Raw Value (dBUV)	Correction Factor (dB/m)
1	100.09	23.9 QP	43.5	-19.6	3.00 H	105	41.2	-17.3
2	167.58	34.9 QP	43.5	-8.6	2.00 H	296	48.0	-13.1
<b>3</b>	<b>234.66</b>	<b>42.7 QP</b>	<b>46.0</b>	<b>-3.3</b>	<b>1.50 H</b>	<b>114</b>	<b>57.5</b>	<b>-14.8</b>
4	300.97	29.8 QP	46.0	-16.2	1.00 H	132	42.0	-12.2
5	434.46	26.3 QP	46.0	-19.7	3.00 H	86	34.9	-8.6
6	612.15	24.0 QP	46.0	-22.0	3.00 H	150	28.9	-4.9

#### Remarks:

- Emission Level(dBUV/m) = Raw Value(dBUV) + Correction Factor(dB/m)
- Correction Factor(dB/m) = Antenna Factor(dB/m) + Cable Factor(dB) – Pre-Amplifier Factor(dB)
- Margin value = Emission Level – Limit value
- The other emission levels were very low against the limit of frequency range 30 MHz ~ 1 GHz.
- The emission levels were very low against the limit of frequency range 9 kHz ~ 30 MHz: the amplitude of spurious emissions attenuated more than 20 dB below the permissible value to be report.

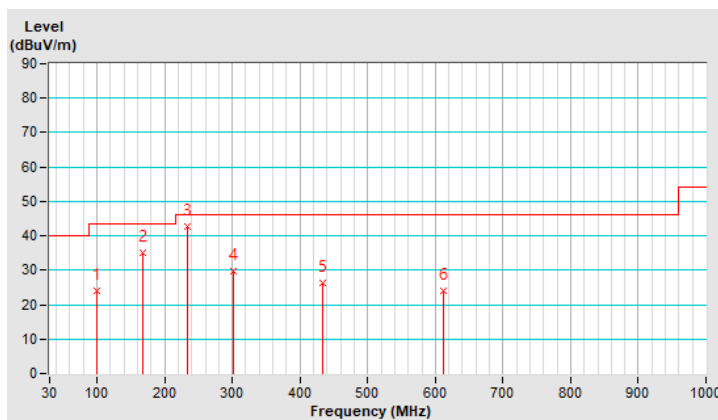

<b>RF Mode</b>	TX BT GFSK	<b>Channel</b>	CH 39 : 2441 MHz
<b>Frequency Range</b>	9 kHz ~ 1 GHz	<b>Detector Function &amp; Bandwidth</b>	(QP) RB = 120kHz
<b>Input Power (System)</b>	120 Vac, 60Hz	<b>Environmental Conditions</b>	19°C, 64% RH
<b>Tested By</b>	Sampson Chen		

Antenna Polarity & Test Distance : Vertical at 3 m								
No	Frequency (MHz)	Emission Level (dBuV/m)	Limit (dBuV/m)	Margin (dB)	Antenna Height (m)	Table Angle (Degree)	Raw Value (dBuV)	Correction Factor (dB/m)
1	57.02	21.6 QP	40.0	-18.4	1.50 V	315	34.8	-13.2
2	148.04	25.4 QP	43.5	-18.1	1.00 V	121	38.1	-12.7
3	198.45	27.5 QP	43.5	-16.0	1.50 V	249	43.6	-16.1
4	233.23	33.8 QP	46.0	-12.2	2.00 V	65	48.8	-15.0
5	342.70	26.4 QP	46.0	-19.6	1.50 V	187	37.7	-11.3
6	746.42	35.5 QP	46.0	-10.5	3.00 V	302	38.4	-2.9

**Remarks:**

1. Emission Level(dBuV/m) = Raw Value(dBuV) + Correction Factor(dB/m)
2. Correction Factor(dB/m) = Antenna Factor(dB/m) + Cable Factor(dB) – Pre-Amplifier Factor(dB)
3. Margin value = Emission Level – Limit value
4. The other emission levels were very low against the limit of frequency range 30 MHz ~ 1 GHz.
5. The emission levels were very low against the limit of frequency range 9 kHz ~ 30 MHz: the amplitude of spurious emissions attenuated more than 20 dB below the permissible value to be report.

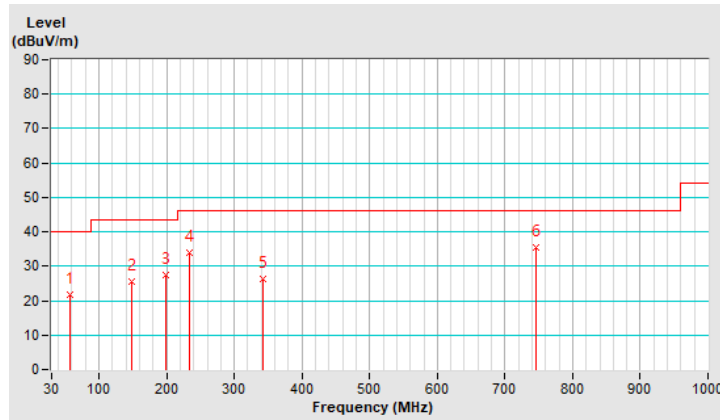

Mode B

RF Mode	TX BT GFSK	Channel	CH 39 : 2441 MHz
Frequency Range	9 kHz ~ 1 GHz	Detector Function & Bandwidth	(QP) RB = 120kHz
Input Power (System)	120 Vac, 60Hz	Environmental Conditions	19°C, 64% RH
Tested By	Sampson Chen		

Antenna Polarity & Test Distance : Horizontal at 3 m								
No	Frequency (MHz)	Emission Level (dBUV/m)	Limit (dBUV/m)	Margin (dB)	Antenna Height (m)	Table Angle (Degree)	Raw Value (dBUV)	Correction Factor (dB/m)
1	100.14	23.9 QP	43.5	-19.6	3.00 H	94	41.2	-17.3
2	167.52	34.8 QP	43.5	-8.7	2.00 H	295	47.9	-13.1
3	234.99	42.3 QP	46.0	-3.7	1.50 H	106	57.1	-14.8
4	300.01	30.6 QP	46.0	-15.4	1.00 H	139	42.9	-12.3
5	434.22	26.0 QP	46.0	-20.0	3.00 H	88	34.6	-8.6
6	611.76	23.9 QP	46.0	-22.1	3.00 H	154	28.8	-4.9

Remarks:

1. Emission Level(dBUV/m) = Raw Value(dBuV) + Correction Factor(dB/m)
2. Correction Factor(dB/m) = Antenna Factor(dB/m) + Cable Factor(dB) – Pre-Amplifier Factor(dB)
3. Margin value = Emission Level – Limit value
4. The other emission levels were very low against the limit of frequency range 30 MHz ~ 1 GHz.
5. The emission levels were very low against the limit of frequency range 9 kHz ~ 30 MHz: the amplitude of spurious emissions attenuated more than 20 dB below the permissible value to be report.

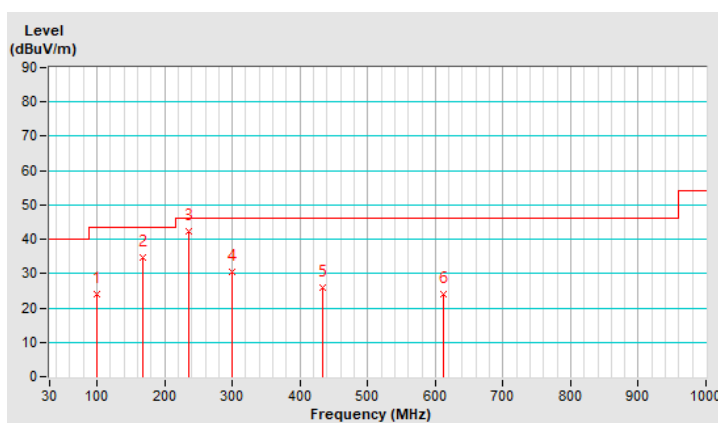

<b>RF Mode</b>	TX BT GFSK	<b>Channel</b>	CH 39 : 2441 MHz
<b>Frequency Range</b>	9 kHz ~ 1 GHz	<b>Detector Function &amp; Bandwidth</b>	(QP) RB = 120kHz
<b>Input Power (System)</b>	120 Vac, 60Hz	<b>Environmental Conditions</b>	19°C, 64% RH
<b>Tested By</b>	Sampson Chen		

Antenna Polarity & Test Distance : Vertical at 3 m								
No	Frequency (MHz)	Emission Level (dBuV/m)	Limit (dBuV/m)	Margin (dB)	Antenna Height (m)	Table Angle (Degree)	Raw Value (dBuV)	Correction Factor (dB/m)
1	55.93	20.8 QP	40.0	-19.2	1.50 V	329	33.6	-12.8
2	147.74	25.2 QP	43.5	-18.3	1.00 V	128	37.9	-12.7
3	198.79	27.5 QP	43.5	-16.0	1.50 V	245	43.6	-16.1
4	232.93	33.0 QP	46.0	-13.0	2.00 V	58	48.1	-15.1
5	342.02	26.2 QP	46.0	-19.8	1.50 V	191	37.4	-11.2
6	747.37	36.1 QP	46.0	-9.9	3.00 V	289	38.9	-2.8

**Remarks:**

1. Emission Level(dBuV/m) = Raw Value(dBuV) + Correction Factor(dB/m)
2. Correction Factor(dB/m) = Antenna Factor(dB/m) + Cable Factor(dB) – Pre-Amplifier Factor(dB)
3. Margin value = Emission Level – Limit value
4. The other emission levels were very low against the limit of frequency range 30 MHz ~ 1 GHz.
5. The emission levels were very low against the limit of frequency range 9 kHz ~ 30 MHz: the amplitude of spurious emissions attenuated more than 20 dB below the permissible value to be report.

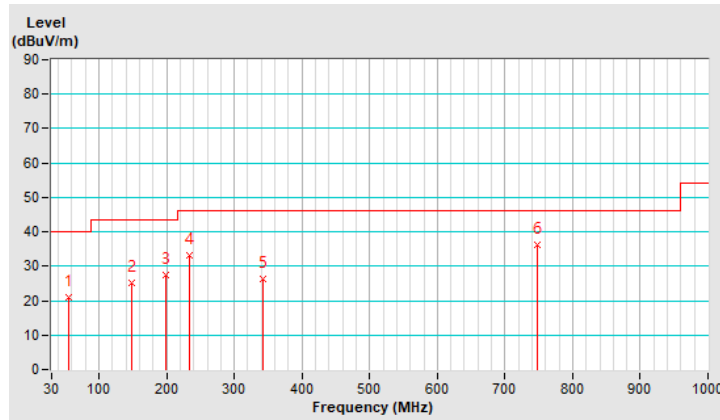

## Mode C

<b>RF Mode</b>	TX BT GFSK	<b>Channel</b>	CH 39 : 2441 MHz
<b>Frequency Range</b>	9 kHz ~ 1 GHz	<b>Detector Function &amp; Bandwidth</b>	(QP) RB = 120kHz
<b>Input Power (System)</b>	120 Vac, 60Hz	<b>Environmental Conditions</b>	19°C, 64% RH
<b>Tested By</b>	Sampson Chen		

Antenna Polarity & Test Distance : Horizontal at 3 m								
No	Frequency (MHz)	Emission Level (dBuV/m)	Limit (dBuV/m)	Margin (dB)	Antenna Height (m)	Table Angle (Degree)	Raw Value (dBuV)	Correction Factor (dB/m)
1	100.32	24.7 QP	43.5	-18.8	3.00 H	118	42.0	-17.3
2	167.29	34.2 QP	43.5	-9.3	2.00 H	303	47.3	-13.1
3	234.85	42.6 QP	46.0	-3.4	1.50 H	94	57.4	-14.8
4	299.98	30.4 QP	46.0	-15.6	1.00 H	159	42.7	-12.3
5	434.05	25.9 QP	46.0	-20.1	3.00 H	90	34.5	-8.6
6	613.08	25.0 QP	46.0	-21.0	3.00 H	148	29.9	-4.9

### Remarks:

1. Emission Level(dBuV/m) = Raw Value(dBuV) + Correction Factor(dB/m)
2. Correction Factor(dB/m) = Antenna Factor(dB/m) + Cable Factor(dB) – Pre-Amplifier Factor(dB)
3. Margin value = Emission Level – Limit value
4. The other emission levels were very low against the limit of frequency range 30 MHz ~ 1 GHz.
5. The emission levels were very low against the limit of frequency range 9 kHz ~ 30 MHz: the amplitude of spurious emissions attenuated more than 20 dB below the permissible value to be report.

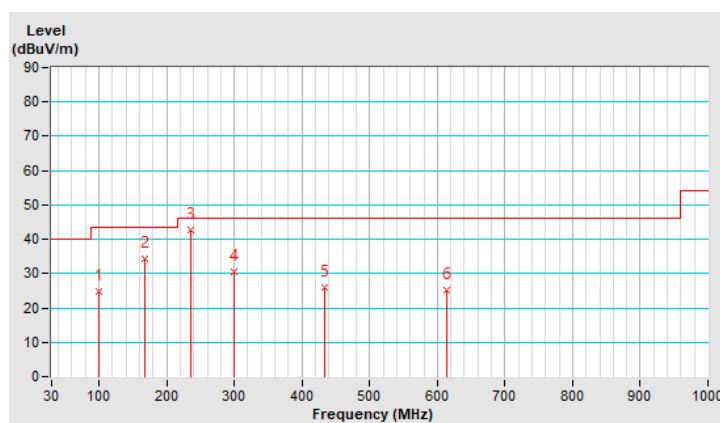

<b>RF Mode</b>	TX BT GFSK	<b>Channel</b>	CH 39 : 2441 MHz
<b>Frequency Range</b>	9 kHz ~ 1 GHz	<b>Detector Function &amp; Bandwidth</b>	(QP) RB = 120kHz
<b>Input Power (System)</b>	120 Vac, 60Hz	<b>Environmental Conditions</b>	19°C, 64% RH
<b>Tested By</b>	Sampson Chen		

Antenna Polarity & Test Distance : Vertical at 3 m								
No	Frequency (MHz)	Emission Level (dBuV/m)	Limit (dBuV/m)	Margin (dB)	Antenna Height (m)	Table Angle (Degree)	Raw Value (dBuV)	Correction Factor (dB/m)
1	57.00	21.6 QP	40.0	-18.4	1.50 V	312	34.8	-13.2
2	147.88	25.0 QP	43.5	-18.5	1.00 V	99	37.7	-12.7
3	198.43	27.0 QP	43.5	-16.5	1.50 V	247	43.1	-16.1
4	232.84	33.4 QP	46.0	-12.6	2.00 V	44	48.5	-15.1
5	341.84	26.2 QP	46.0	-19.8	1.50 V	183	37.4	-11.2
6	748.19	36.7 QP	46.0	-9.3	3.00 V	310	39.5	-2.8

**Remarks:**

1. Emission Level(dBuV/m) = Raw Value(dBuV) + Correction Factor(dB/m)
2. Correction Factor(dB/m) = Antenna Factor(dB/m) + Cable Factor(dB) – Pre-Amplifier Factor(dB)
3. Margin value = Emission Level – Limit value
4. The other emission levels were very low against the limit of frequency range 30 MHz ~ 1 GHz.
5. The emission levels were very low against the limit of frequency range 9 kHz ~ 30 MHz: the amplitude of spurious emissions attenuated more than 20 dB below the permissible value to be report.

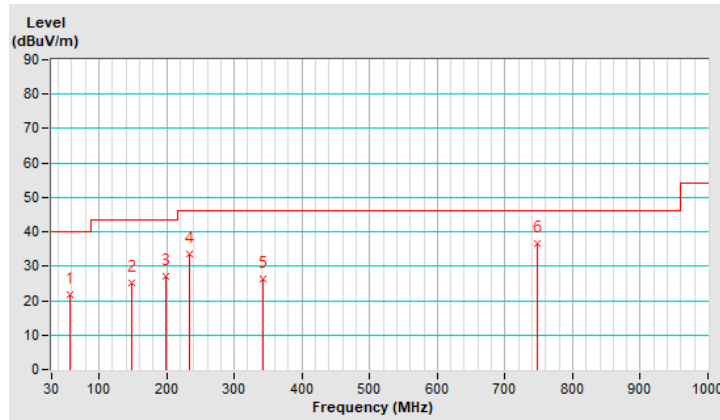

## Mode D

<b>RF Mode</b>	TX BT GFSK	<b>Channel</b>	CH 39 : 2441 MHz
<b>Frequency Range</b>	9 kHz ~ 1 GHz	<b>Detector Function &amp; Bandwidth</b>	(QP) RB = 120kHz
<b>Input Power (System)</b>	120 Vac, 60Hz	<b>Environmental Conditions</b>	19°C, 64% RH
<b>Tested By</b>	Sampson Chen		

Antenna Polarity & Test Distance : Horizontal at 3 m								
No	Frequency (MHz)	Emission Level (dBuV/m)	Limit (dBuV/m)	Margin (dB)	Antenna Height (m)	Table Angle (Degree)	Raw Value (dBuV)	Correction Factor (dB/m)
1	100.68	24.5 QP	43.5	-19.0	3.00 H	99	41.7	-17.2
2	166.83	34.0 QP	43.5	-9.5	2.00 H	306	47.1	-13.1
3	234.32	42.4 QP	46.0	-3.6	1.50 H	124	57.3	-14.9
4	299.49	29.6 QP	46.0	-16.4	1.00 H	156	41.9	-12.3
5	434.84	26.9 QP	46.0	-19.1	3.00 H	79	35.5	-8.6
6	612.17	24.3 QP	46.0	-21.7	3.00 H	144	29.2	-4.9

### Remarks:

1. Emission Level(dBuV/m) = Raw Value(dBuV) + Correction Factor(dB/m)
2. Correction Factor(dB/m) = Antenna Factor(dB/m) + Cable Factor(dB) – Pre-Amplifier Factor(dB)
3. Margin value = Emission Level – Limit value
4. The other emission levels were very low against the limit of frequency range 30 MHz ~ 1 GHz.
5. The emission levels were very low against the limit of frequency range 9 kHz ~ 30 MHz: the amplitude of spurious emissions attenuated more than 20 dB below the permissible value to be report.

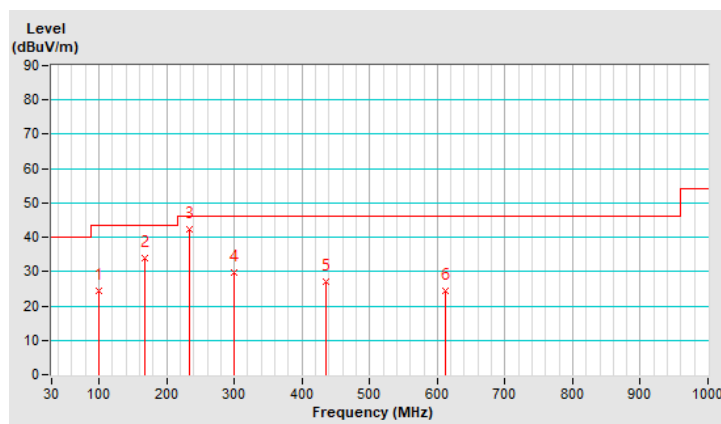

<b>RF Mode</b>	TX BT GFSK	<b>Channel</b>	CH 39 : 2441 MHz
<b>Frequency Range</b>	9 kHz ~ 1 GHz	<b>Detector Function &amp; Bandwidth</b>	(QP) RB = 120kHz
<b>Input Power (System)</b>	120 Vac, 60Hz	<b>Environmental Conditions</b>	19°C, 64% RH
<b>Tested By</b>	Sampson Chen		

Antenna Polarity & Test Distance : Vertical at 3 m								
No	Frequency (MHz)	Emission Level (dBuV/m)	Limit (dBuV/m)	Margin (dB)	Antenna Height (m)	Table Angle (Degree)	Raw Value (dBuV)	Correction Factor (dB/m)
1	56.89	21.8 QP	40.0	-18.2	1.50 V	316	35.0	-13.2
2	147.43	24.6 QP	43.5	-18.9	1.00 V	118	37.3	-12.7
3	198.12	27.2 QP	43.5	-16.3	1.50 V	245	43.3	-16.1
4	233.20	33.2 QP	46.0	-12.8	2.00 V	62	48.2	-15.0
5	342.52	26.2 QP	46.0	-19.8	1.50 V	183	37.5	-11.3
6	747.64	36.4 QP	46.0	-9.6	3.00 V	287	39.2	-2.8

**Remarks:**

1. Emission Level(dBuV/m) = Raw Value(dBuV) + Correction Factor(dB/m)
2. Correction Factor(dB/m) = Antenna Factor(dB/m) + Cable Factor(dB) – Pre-Amplifier Factor(dB)
3. Margin value = Emission Level – Limit value
4. The other emission levels were very low against the limit of frequency range 30 MHz ~ 1 GHz.
5. The emission levels were very low against the limit of frequency range 9 kHz ~ 30 MHz: the amplitude of spurious emissions attenuated more than 20 dB below the permissible value to be report.

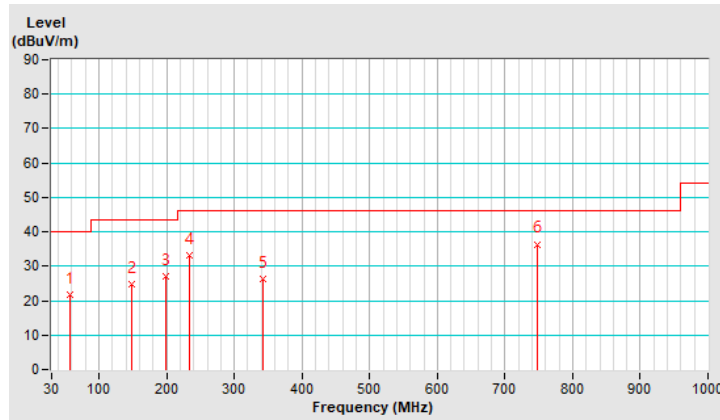



## 7.9 Unwanted Emissions above 1 GHz

### Mode A

RF Mode	TX BT GFSK	Channel	CH 0 : 2402 MHz
Frequency Range	1 GHz ~ 25 GHz	Detector Function & Bandwidth	(PK) RB = 1 MHz, VB = 3 MHz (AV) RB = 1 MHz, VB = 3 MHz
Input Power (System)	120 Vac, 60Hz	Environmental Conditions	25°C, 67% RH
Tested By	Sampson Chen		

Antenna Polarity & Test Distance : Horizontal at 3 m								
No	Frequency (MHz)	Emission Level (dBuV/m)	Limit (dBuV/m)	Margin (dB)	Antenna Height (m)	Table Angle (Degree)	Raw Value (dBuV)	Correction Factor (dB/m)
1	2376.09	55.8 PK	74.0	-18.2	1.14 H	153	58.4	-2.6
2	2376.09	43.0 AV	54.0	-11.0	1.14 H	153	45.6	-2.6
3	*2402.00	93.5 PK			1.14 H	153	96.2	-2.7
4	*2402.00	66.0 AV			1.14 H	153	68.7	-2.7
5	4804.00	36.2 PK	74.0	-37.8	1.62 H	158	34.7	1.5
6	4804.00	8.7 AV	54.0	-45.3	1.62 H	158	7.2	1.5

#### Remarks:

- Emission Level(dBuV/m) = Raw Value(dBuV) + Correction Factor(dB/m)
- Correction Factor(dB/m) = Antenna Factor(dB/m) + Cable Factor(dB) – Pre-Amplifier Factor(dB)
- Margin value = Emission Level – Limit value
- The other emission levels were very low against the limit.
- " \* " : Fundamental frequency, the limit was restricted at the RF Output Power.
- The average value of fundamental and harmonic frequency is: Average = Peak value + 20 log(Duty cycle) Where the duty cycle correction factor is calculated from following formula:  
 $20 \log(\text{Duty cycle}) = 20 \log(4.2 \text{ ms} / 100 \text{ ms}) = -27.5 \text{ dB}$

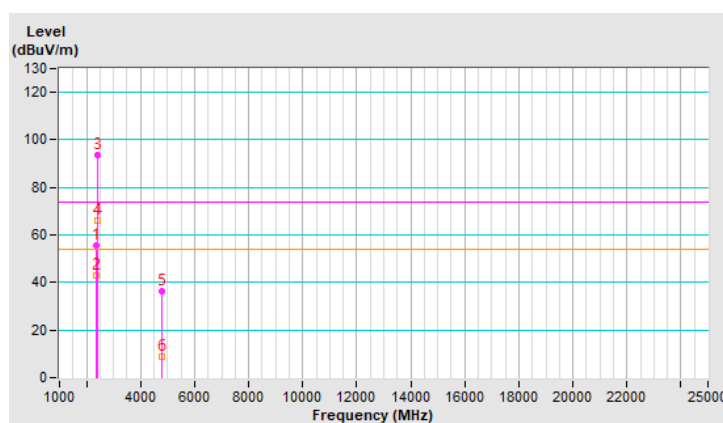

<b>RF Mode</b>	TX BT GFSK	<b>Channel</b>	CH 0 : 2402 MHz
<b>Frequency Range</b>	1 GHz ~ 25 GHz	<b>Detector Function &amp; Bandwidth</b>	(PK) RB = 1 MHz, VB = 3 MHz (AV) RB = 1 MHz, VB = 3 MHz
<b>Input Power (System)</b>	120 Vac, 60Hz	<b>Environmental Conditions</b>	25°C, 67% RH
<b>Tested By</b>	Sampson Chen		

Antenna Polarity & Test Distance : Vertical at 3 m								
No	Frequency (MHz)	Emission Level (dBuV/m)	Limit (dBuV/m)	Margin (dB)	Antenna Height (m)	Table Angle (Degree)	Raw Value (dBuV)	Correction Factor (dB/m)
1	2387.49	55.7 PK	74.0	-18.3	1.55 V	237	58.4	-2.7
2	2387.49	43.4 AV	54.0	-10.6	1.55 V	237	46.1	-2.7
3	*2402.00	103.9 PK			1.55 V	237	106.6	-2.7
4	*2402.00	76.4 AV			1.55 V	237	79.1	-2.7
5	4804.00	41.9 PK	74.0	-32.1	1.27 V	291	40.4	1.5
6	4804.00	14.4 AV	54.0	-39.6	1.27 V	291	12.9	1.5

**Remarks:**

1. Emission Level(dBuV/m) = Raw Value(dBuV) + Correction Factor(dB/m)
2. Correction Factor(dB/m) = Antenna Factor(dB/m) + Cable Factor(dB) – Pre-Amplifier Factor(dB)
3. Margin value = Emission Level – Limit value
4. The other emission levels were very low against the limit.
5. " \* " : Fundamental frequency, the limit was restricted at the RF Output Power.
6. The average value of fundamental and harmonic frequency is: Average = Peak value + 20 log(Duty cycle) Where the duty cycle correction factor is calculated from following formula:  
 $20 \log(\text{Duty cycle}) = 20 \log(4.2 \text{ ms} / 100 \text{ ms}) = -27.5 \text{ dB}$

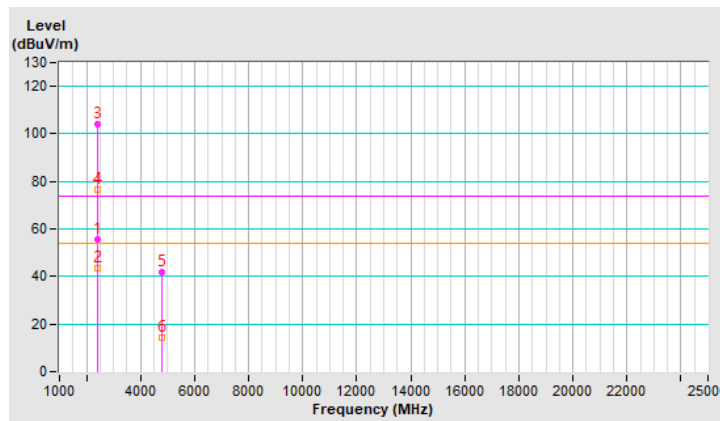

<b>RF Mode</b>	TX BT GFSK	<b>Channel</b>	CH 39 : 2441 MHz
<b>Frequency Range</b>	1 GHz ~ 25 GHz	<b>Detector Function &amp; Bandwidth</b>	(PK) RB = 1 MHz, VB = 3 MHz (AV) RB = 1 MHz, VB = 3 MHz
<b>Input Power (System)</b>	120 Vac, 60Hz	<b>Environmental Conditions</b>	25°C, 67% RH
<b>Tested By</b>	Sampson Chen		

Antenna Polarity & Test Distance : Horizontal at 3 m								
No	Frequency (MHz)	Emission Level (dBuV/m)	Limit (dBuV/m)	Margin (dB)	Antenna Height (m)	Table Angle (Degree)	Raw Value (dBuV)	Correction Factor (dB/m)
1	*2441.00	93.4 PK			1.10 H	131	96.2	-2.8
2	*2441.00	65.9 AV			1.10 H	131	68.7	-2.8
3	4882.00	35.7 PK	74.0	-38.3	1.62 H	175	34.2	1.5
4	4882.00	8.2 AV	54.0	-45.8	1.62 H	175	6.7	1.5
5	7323.00	42.6 PK	74.0	-31.4	1.78 H	201	35.4	7.2
6	7323.00	15.1 AV	54.0	-38.9	1.78 H	201	7.9	7.2

**Remarks:**

- Emission Level(dBuV/m) = Raw Value(dBuV) + Correction Factor(dB/m)
- Correction Factor(dB/m) = Antenna Factor(dB/m) + Cable Factor(dB) – Pre-Amplifier Factor(dB)
- Margin value = Emission Level – Limit value
- The other emission levels were very low against the limit.
- " \* " : Fundamental frequency, the limit was restricted at the RF Output Power.
- The average value of fundamental and harmonic frequency is: Average = Peak value + 20 log(Duty cycle) Where the duty cycle correction factor is calculated from following formula:  
 $20 \log(\text{Duty cycle}) = 20 \log(4.2 \text{ ms} / 100 \text{ ms}) = -27.5 \text{ dB}$

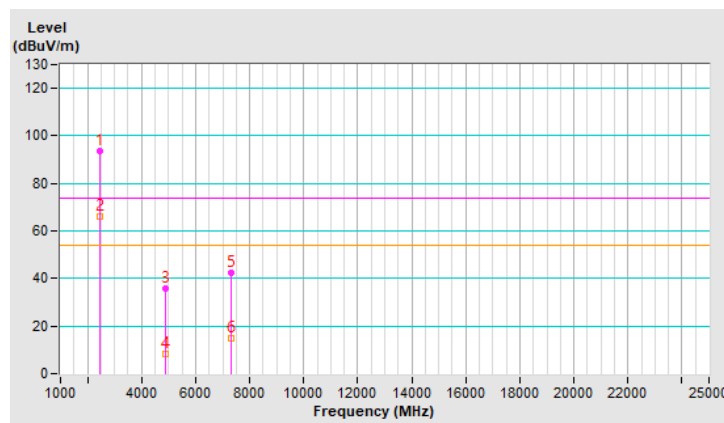

<b>RF Mode</b>	TX BT GFSK	<b>Channel</b>	CH 39 : 2441 MHz
<b>Frequency Range</b>	1 GHz ~ 25 GHz	<b>Detector Function &amp; Bandwidth</b>	(PK) RB = 1 MHz, VB = 3 MHz (AV) RB = 1 MHz, VB = 3 MHz
<b>Input Power (System)</b>	120 Vac, 60Hz	<b>Environmental Conditions</b>	25°C, 67% RH
<b>Tested By</b>	Sampson Chen		

Antenna Polarity & Test Distance : Vertical at 3 m								
No	Frequency (MHz)	Emission Level (dBuV/m)	Limit (dBuV/m)	Margin (dB)	Antenna Height (m)	Table Angle (Degree)	Raw Value (dBuV)	Correction Factor (dB/m)
1	*2441.00	104.0 PK			1.59 V	224	106.8	-2.8
2	*2441.00	76.5 AV			1.59 V	224	79.3	-2.8
3	4882.00	42.2 PK	74.0	-31.8	1.34 V	271	40.7	1.5
4	4882.00	14.7 AV	54.0	-39.3	1.34 V	271	13.2	1.5
5	7323.00	43.3 PK	74.0	-30.7	1.57 V	261	36.1	7.2
6	7323.00	15.8 AV	54.0	-38.2	1.57 V	261	8.6	7.2

**Remarks:**

1. Emission Level(dBuV/m) = Raw Value(dBuV) + Correction Factor(dB/m)
2. Correction Factor(dB/m) = Antenna Factor(dB/m) + Cable Factor(dB) – Pre-Amplifier Factor(dB)
3. Margin value = Emission Level – Limit value
4. The other emission levels were very low against the limit.
5. " \* " : Fundamental frequency, the limit was restricted at the RF Output Power.
6. The average value of fundamental and harmonic frequency is: Average = Peak value + 20 log(Duty cycle) Where the duty cycle correction factor is calculated from following formula:  
 $20 \log(\text{Duty cycle}) = 20 \log(4.2 \text{ ms} / 100 \text{ ms}) = -27.5 \text{ dB}$

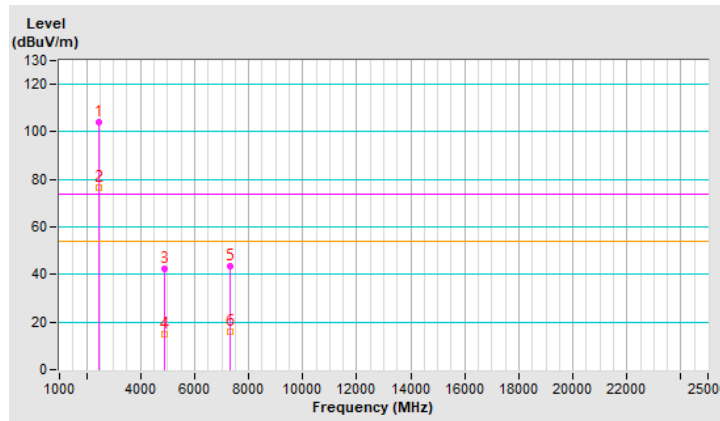

<b>RF Mode</b>	TX BT GFSK	<b>Channel</b>	CH 78 : 2480 MHz
<b>Frequency Range</b>	1 GHz ~ 25 GHz	<b>Detector Function &amp; Bandwidth</b>	(PK) RB = 1 MHz, VB = 3 MHz (AV) RB = 1 MHz, VB = 3 MHz
<b>Input Power (System)</b>	120 Vac, 60Hz	<b>Environmental Conditions</b>	25°C, 67% RH
<b>Tested By</b>	Sampson Chen		

Antenna Polarity & Test Distance : Horizontal at 3 m								
No	Frequency (MHz)	Emission Level (dBuV/m)	Limit (dBuV/m)	Margin (dB)	Antenna Height (m)	Table Angle (Degree)	Raw Value (dBuV)	Correction Factor (dB/m)
1	*2480.00	92.2 PK			1.12 H	144	95.1	-2.9
2	*2480.00	64.7 AV			1.12 H	144	67.6	-2.9
3	2493.42	55.8 PK	74.0	-18.2	1.12 H	144	58.7	-2.9
4	2493.42	43.2 AV	54.0	-10.8	1.12 H	144	46.1	-2.9
5	4960.00	35.8 PK	74.0	-38.2	1.46 H	168	34.1	1.7
6	4960.00	8.3 AV	54.0	-45.7	1.46 H	168	6.6	1.7
7	7440.00	42.3 PK	74.0	-31.7	1.89 H	209	34.7	7.6
8	7440.00	14.8 AV	54.0	-39.2	1.89 H	209	7.2	7.6

**Remarks:**

1. Emission Level(dBuV/m) = Raw Value(dBuV) + Correction Factor(dB/m)
2. Correction Factor(dB/m) = Antenna Factor(dB/m) + Cable Factor(dB) – Pre-Amplifier Factor(dB)
3. Margin value = Emission Level – Limit value
4. The other emission levels were very low against the limit.
5. " \* ": Fundamental frequency, the limit was restricted at the RF Output Power.
6. The average value of fundamental and harmonic frequency is: Average = Peak value + 20 log(Duty cycle) Where the duty cycle correction factor is calculated from following formula:  
 $20 \log(\text{Duty cycle}) = 20 \log(4.2 \text{ ms} / 100 \text{ ms}) = -27.5 \text{ dB}$

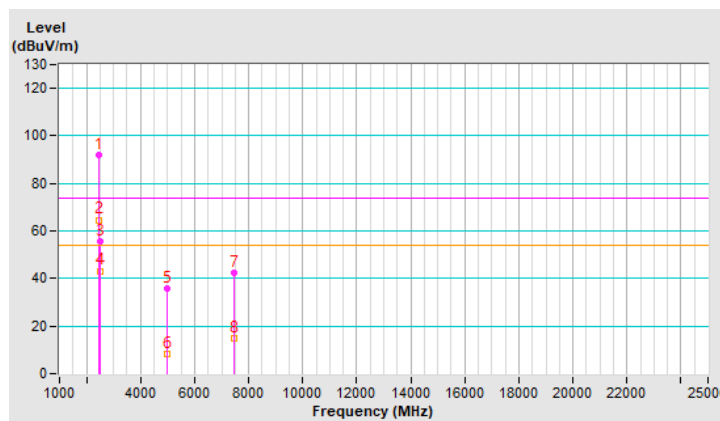

<b>RF Mode</b>	TX BT GFSK	<b>Channel</b>	CH 78 : 2480 MHz
<b>Frequency Range</b>	1 GHz ~ 25 GHz	<b>Detector Function &amp; Bandwidth</b>	(PK) RB = 1 MHz, VB = 3 MHz (AV) RB = 1 MHz, VB = 3 MHz
<b>Input Power (System)</b>	120 Vac, 60Hz	<b>Environmental Conditions</b>	25°C, 67% RH
<b>Tested By</b>	Sampson Chen		

Antenna Polarity & Test Distance : Vertical at 3 m								
No	Frequency (MHz)	Emission Level (dBuV/m)	Limit (dBuV/m)	Margin (dB)	Antenna Height (m)	Table Angle (Degree)	Raw Value (dBuV)	Correction Factor (dB/m)
1	*2480.00	104.5 PK			1.65 V	229	107.4	-2.9
2	*2480.00	77.0 AV			1.65 V	229	79.9	-2.9
3	2484.38	56.1 PK	74.0	-17.9	1.65 V	229	59.0	-2.9
4	2484.38	43.8 AV	54.0	-10.2	1.65 V	229	46.7	-2.9
5	4960.00	42.2 PK	74.0	-31.8	1.25 V	305	40.5	1.7
6	4960.00	14.7 AV	54.0	-39.3	1.25 V	305	13.0	1.7
7	7440.00	42.2 PK	74.0	-31.8	1.48 V	276	34.6	7.6
8	7440.00	14.7 AV	54.0	-39.3	1.48 V	276	7.1	7.6

**Remarks:**

1. Emission Level(dBuV/m) = Raw Value(dBuV) + Correction Factor(dB/m)
2. Correction Factor(dB/m) = Antenna Factor(dB/m) + Cable Factor(dB) – Pre-Amplifier Factor(dB)
3. Margin value = Emission Level – Limit value
4. The other emission levels were very low against the limit.
5. " \* ": Fundamental frequency, the limit was restricted at the RF Output Power.
6. The average value of fundamental and harmonic frequency is: Average = Peak value + 20 log(Duty cycle) Where the duty cycle correction factor is calculated from following formula:  
 $20 \log(\text{Duty cycle}) = 20 \log(4.2 \text{ ms} / 100 \text{ ms}) = -27.5 \text{ dB}$

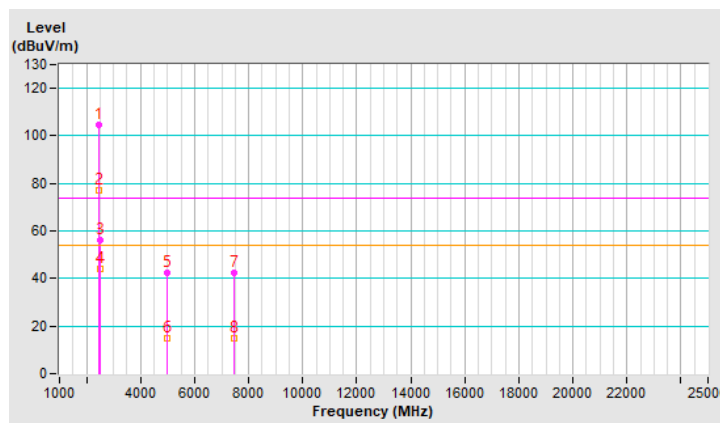

<b>RF Mode</b>	TX BT 8DPSK	<b>Channel</b>	CH 0 : 2402 MHz
<b>Frequency Range</b>	1 GHz ~ 25 GHz	<b>Detector Function &amp; Bandwidth</b>	(PK) RB = 1 MHz, VB = 3 MHz (AV) RB = 1 MHz, VB = 3 MHz
<b>Input Power (System)</b>	120 Vac, 60Hz	<b>Environmental Conditions</b>	25°C, 67% RH
<b>Tested By</b>	Sampson Chen		

**Antenna Polarity & Test Distance : Horizontal at 3 m**

No	Frequency (MHz)	Emission Level (dBuV/m)	Limit (dBuV/m)	Margin (dB)	Antenna Height (m)	Table Angle (Degree)	Raw Value (dBuV)	Correction Factor (dB/m)
1	2369.97	55.1 PK	74.0	-18.9	1.07 H	137	57.8	-2.7
2	2369.97	43.0 AV	54.0	-11.0	1.07 H	137	45.7	-2.7
3	*2402.00	95.0 PK			1.07 H	137	97.7	-2.7
4	*2402.00	67.0 AV			1.07 H	137	69.7	-2.7
5	4804.00	36.0 PK	74.0	-38.0	1.55 H	154	34.5	1.5
6	4804.00	8.0 AV	54.0	-46.0	1.55 H	154	6.5	1.5

**Remarks:**

1. Emission Level(dBuV/m) = Raw Value(dBuV) + Correction Factor(dB/m)
2. Correction Factor(dB/m) = Antenna Factor(dB/m) + Cable Factor(dB) – Pre-Amplifier Factor(dB)
3. Margin value = Emission Level – Limit value
4. The other emission levels were very low against the limit.
5. " \* " : Fundamental frequency, the limit was restricted at the RF Output Power.
6. The average value of fundamental and harmonic frequency is: Average = Peak value + 20 log(Duty cycle) Where the duty cycle correction factor is calculated from following formula:  
 $20 \log(\text{Duty cycle}) = 20 \log(4 \text{ ms} / 100 \text{ ms}) = -28.0 \text{ dB}$

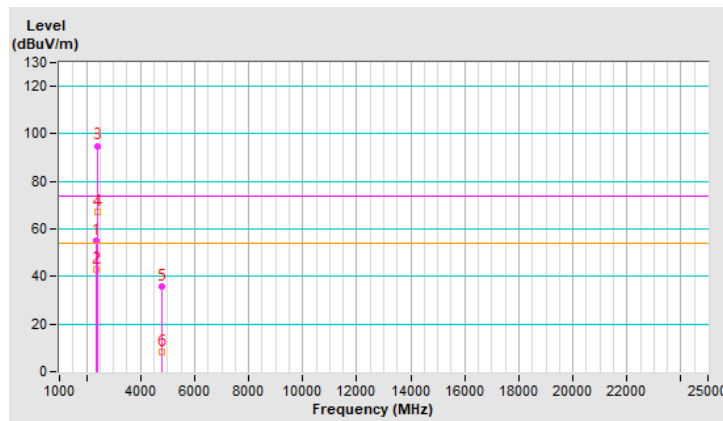

<b>RF Mode</b>	TX BT 8DPSK	<b>Channel</b>	CH 0 : 2402 MHz
<b>Frequency Range</b>	1 GHz ~ 25 GHz	<b>Detector Function &amp; Bandwidth</b>	(PK) RB = 1 MHz, VB = 3 MHz (AV) RB = 1 MHz, VB = 3 MHz
<b>Input Power (System)</b>	120 Vac, 60Hz	<b>Environmental Conditions</b>	25°C, 67% RH
<b>Tested By</b>	Sampson Chen		

Antenna Polarity & Test Distance : Vertical at 3 m								
No	Frequency (MHz)	Emission Level (dBuV/m)	Limit (dBuV/m)	Margin (dB)	Antenna Height (m)	Table Angle (Degree)	Raw Value (dBuV)	Correction Factor (dB/m)
1	2370.83	56.3 PK	74.0	-17.7	1.64 V	228	59.0	-2.7
2	2370.83	43.2 AV	54.0	-10.8	1.64 V	228	45.9	-2.7
3	*2402.00	105.1 PK			1.64 V	228	107.8	-2.7
4	*2402.00	77.1 AV			1.64 V	228	79.8	-2.7
5	4804.00	42.6 PK	74.0	-31.4	1.27 V	303	41.1	1.5
6	4804.00	14.6 AV	54.0	-39.4	1.27 V	303	13.1	1.5

**Remarks:**

1. Emission Level(dBuV/m) = Raw Value(dBuV) + Correction Factor(dB/m)
2. Correction Factor(dB/m) = Antenna Factor(dB/m) + Cable Factor(dB) – Pre-Amplifier Factor(dB)
3. Margin value = Emission Level – Limit value
4. The other emission levels were very low against the limit.
5. " \* " : Fundamental frequency, the limit was restricted at the RF Output Power.
6. The average value of fundamental and harmonic frequency is: Average = Peak value + 20 log(Duty cycle) Where the duty cycle correction factor is calculated from following formula:  
 $20 \log(\text{Duty cycle}) = 20 \log(4 \text{ ms} / 100 \text{ ms}) = -28.0 \text{ dB}$

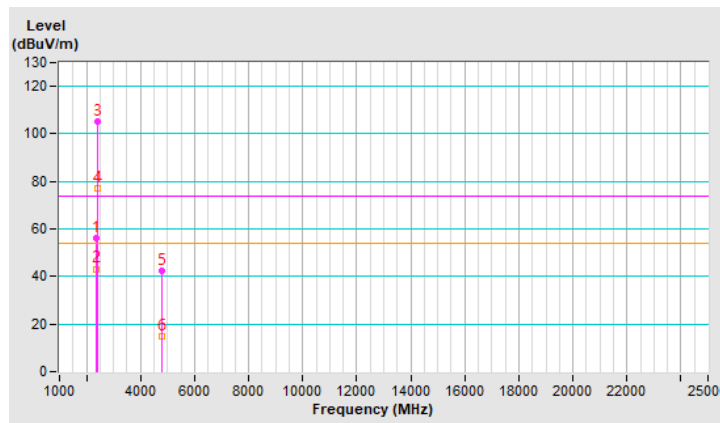



<b>RF Mode</b>	TX BT 8DPSK	<b>Channel</b>	CH 39 : 2441 MHz
<b>Frequency Range</b>	1 GHz ~ 25 GHz	<b>Detector Function &amp; Bandwidth</b>	(PK) RB = 1 MHz, VB = 3 MHz (AV) RB = 1 MHz, VB = 3 MHz
<b>Input Power (System)</b>	120 Vac, 60Hz	<b>Environmental Conditions</b>	25°C, 67% RH
<b>Tested By</b>	Sampson Chen		

Antenna Polarity & Test Distance : Horizontal at 3 m								
No	Frequency (MHz)	Emission Level (dBuV/m)	Limit (dBuV/m)	Margin (dB)	Antenna Height (m)	Table Angle (Degree)	Raw Value (dBuV)	Correction Factor (dB/m)
1	*2441.00	95.0 PK			1.12 H	144	97.8	-2.8
2	*2441.00	67.0 AV			1.12 H	144	69.8	-2.8
3	4882.00	36.3 PK	74.0	-37.7	1.55 H	160	34.8	1.5
4	4882.00	8.3 AV	54.0	-45.7	1.55 H	160	6.8	1.5
5	7323.00	42.0 PK	74.0	-32.0	1.76 H	197	34.8	7.2
6	7323.00	14.0 AV	54.0	-40.0	1.76 H	197	6.8	7.2

**Remarks:**

1. Emission Level(dBuV/m) = Raw Value(dBuV) + Correction Factor(dB/m)
2. Correction Factor(dB/m) = Antenna Factor(dB/m) + Cable Factor(dB) – Pre-Amplifier Factor(dB)
3. Margin value = Emission Level – Limit value
4. The other emission levels were very low against the limit.
5. " \* " : Fundamental frequency, the limit was restricted at the RF Output Power.
6. The average value of fundamental and harmonic frequency is: Average = Peak value + 20 log(Duty cycle) Where the duty cycle correction factor is calculated from following formula:  
 $20 \log(\text{Duty cycle}) = 20 \log(4 \text{ ms} / 100 \text{ ms}) = -28.0 \text{ dB}$

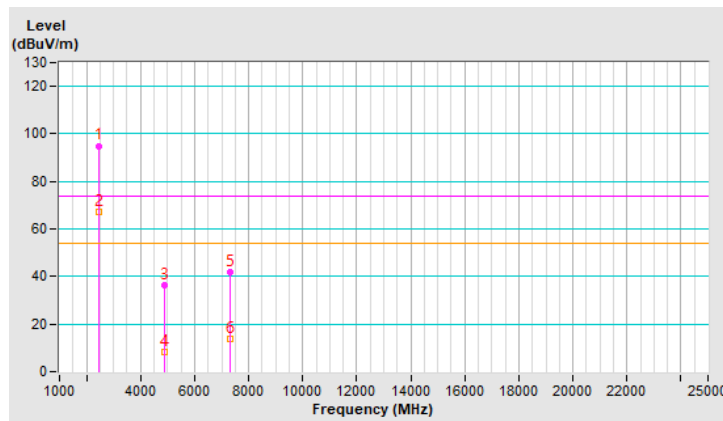

<b>RF Mode</b>	TX BT 8DPSK	<b>Channel</b>	CH 39 : 2441 MHz
<b>Frequency Range</b>	1 GHz ~ 25 GHz	<b>Detector Function &amp; Bandwidth</b>	(PK) RB = 1 MHz, VB = 3 MHz (AV) RB = 1 MHz, VB = 3 MHz
<b>Input Power (System)</b>	120 Vac, 60Hz	<b>Environmental Conditions</b>	25°C, 67% RH
<b>Tested By</b>	Sampson Chen		

Antenna Polarity & Test Distance : Vertical at 3 m								
No	Frequency (MHz)	Emission Level (dBuV/m)	Limit (dBuV/m)	Margin (dB)	Antenna Height (m)	Table Angle (Degree)	Raw Value (dBuV)	Correction Factor (dB/m)
1	*2441.00	105.2 PK			1.58 V	228	108.0	-2.8
2	*2441.00	77.2 AV			1.58 V	228	80.0	-2.8
3	4882.00	42.5 PK	74.0	-31.5	1.24 V	309	41.0	1.5
4	4882.00	14.5 AV	54.0	-39.5	1.24 V	309	13.0	1.5
5	7323.00	42.6 PK	74.0	-31.4	1.46 V	266	35.4	7.2
6	7323.00	14.6 AV	54.0	-39.4	1.46 V	266	7.4	7.2

**Remarks:**

1. Emission Level(dBuV/m) = Raw Value(dBuV) + Correction Factor(dB/m)
2. Correction Factor(dB/m) = Antenna Factor(dB/m) + Cable Factor(dB) – Pre-Amplifier Factor(dB)
3. Margin value = Emission Level – Limit value
4. The other emission levels were very low against the limit.
5. " \* " : Fundamental frequency, the limit was restricted at the RF Output Power.
6. The average value of fundamental and harmonic frequency is: Average = Peak value + 20 log(Duty cycle) Where the duty cycle correction factor is calculated from following formula:  
 $20 \log(\text{Duty cycle}) = 20 \log(4 \text{ ms} / 100 \text{ ms}) = -28.0 \text{ dB}$

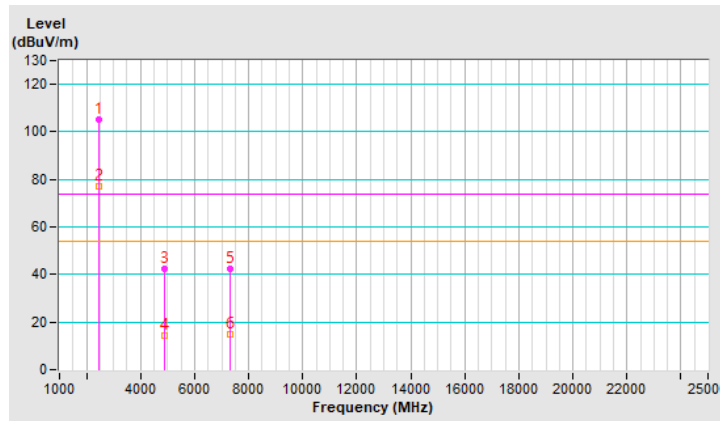

<b>RF Mode</b>	TX BT 8DPSK	<b>Channel</b>	CH 78 : 2480 MHz
<b>Frequency Range</b>	1 GHz ~ 25 GHz	<b>Detector Function &amp; Bandwidth</b>	(PK) RB = 1 MHz, VB = 3 MHz (AV) RB = 1 MHz, VB = 3 MHz
<b>Input Power (System)</b>	120 Vac, 60Hz	<b>Environmental Conditions</b>	25°C, 67% RH
<b>Tested By</b>	Sampson Chen		

Antenna Polarity & Test Distance : Horizontal at 3 m								
No	Frequency (MHz)	Emission Level (dBuV/m)	Limit (dBuV/m)	Margin (dB)	Antenna Height (m)	Table Angle (Degree)	Raw Value (dBuV)	Correction Factor (dB/m)
1	*2480.00	93.8 PK			1.05 H	130	96.7	-2.9
2	*2480.00	65.8 AV			1.05 H	130	68.7	-2.9
3	2486.68	55.3 PK	74.0	-18.7	1.05 H	130	58.2	-2.9
4	2486.68	43.3 AV	54.0	-10.7	1.05 H	130	46.2	-2.9
5	4960.00	36.5 PK	74.0	-37.5	1.48 H	155	34.8	1.7
6	4960.00	8.5 AV	54.0	-45.5	1.48 H	155	6.8	1.7
7	7440.00	42.2 PK	74.0	-31.8	1.79 H	191	34.6	7.6
8	7440.00	14.2 AV	54.0	-39.8	1.79 H	191	6.6	7.6

**Remarks:**

1. Emission Level(dBuV/m) = Raw Value(dBuV) + Correction Factor(dB/m)
2. Correction Factor(dB/m) = Antenna Factor(dB/m) + Cable Factor(dB) – Pre-Amplifier Factor(dB)
3. Margin value = Emission Level – Limit value
4. The other emission levels were very low against the limit.
5. " \* ": Fundamental frequency, the limit was restricted at the RF Output Power.
6. The average value of fundamental and harmonic frequency is: Average = Peak value + 20 log(Duty cycle) Where the duty cycle correction factor is calculated from following formula:  
 $20 \log(\text{Duty cycle}) = 20 \log(4 \text{ ms} / 100 \text{ ms}) = -28.0 \text{ dB}$

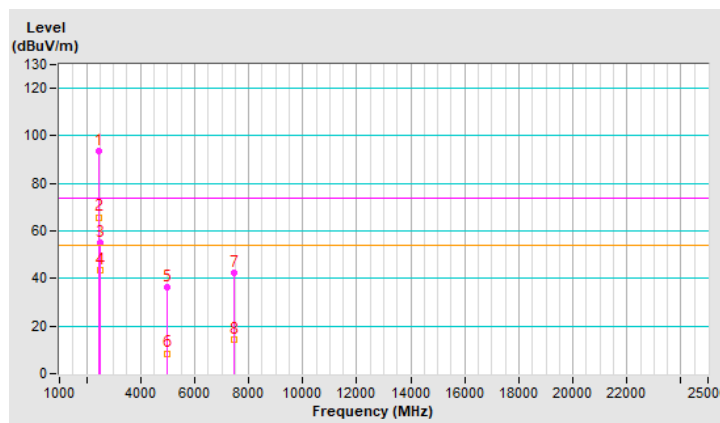

<b>RF Mode</b>	TX BT 8DPSK	<b>Channel</b>	CH 78 : 2480 MHz
<b>Frequency Range</b>	1 GHz ~ 25 GHz	<b>Detector Function &amp; Bandwidth</b>	(PK) RB = 1 MHz, VB = 3 MHz (AV) RB = 1 MHz, VB = 3 MHz
<b>Input Power (System)</b>	120 Vac, 60Hz	<b>Environmental Conditions</b>	25°C, 67% RH
<b>Tested By</b>	Sampson Chen		

Antenna Polarity & Test Distance : Vertical at 3 m								
No	Frequency (MHz)	Emission Level (dBuV/m)	Limit (dBuV/m)	Margin (dB)	Antenna Height (m)	Table Angle (Degree)	Raw Value (dBuV)	Correction Factor (dB/m)
1	*2480.00	106.2 PK			1.63 V	247	109.1	-2.9
2	*2480.00	78.2 AV			1.63 V	247	81.1	-2.9
3	2483.50	56.2 PK	74.0	-17.8	1.63 V	247	59.1	-2.9
4	2483.50	43.9 AV	54.0	-10.1	1.63 V	247	46.8	-2.9
5	4960.00	42.0 PK	74.0	-32.0	1.30 V	317	40.3	1.7
6	4960.00	14.0 AV	54.0	-40.0	1.30 V	317	12.3	1.7
7	7440.00	42.6 PK	74.0	-31.4	1.51 V	281	35.0	7.6
8	7440.00	14.6 AV	54.0	-39.4	1.51 V	281	7.0	7.6

**Remarks:**

1. Emission Level(dBuV/m) = Raw Value(dBuV) + Correction Factor(dB/m)
2. Correction Factor(dB/m) = Antenna Factor(dB/m) + Cable Factor(dB) – Pre-Amplifier Factor(dB)
3. Margin value = Emission Level – Limit value
4. The other emission levels were very low against the limit.
5. " \* ": Fundamental frequency, the limit was restricted at the RF Output Power.
6. The average value of fundamental and harmonic frequency is: Average = Peak value + 20 log(Duty cycle) Where the duty cycle correction factor is calculated from following formula:  
 $20 \log(\text{Duty cycle}) = 20 \log(4 \text{ ms} / 100 \text{ ms}) = -28.0 \text{ dB}$

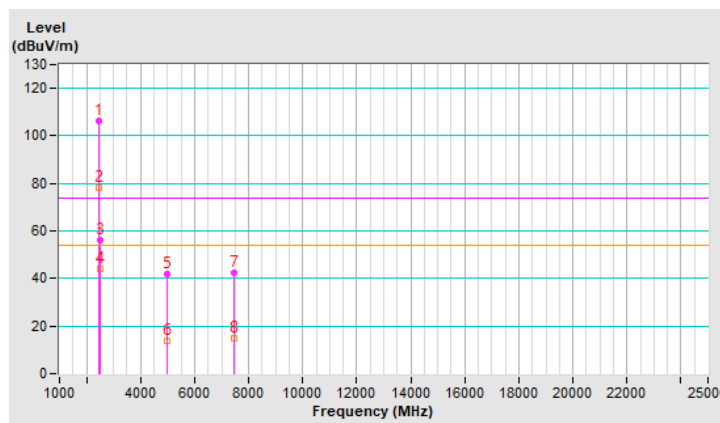

Mode A\_Plot of Band Edge

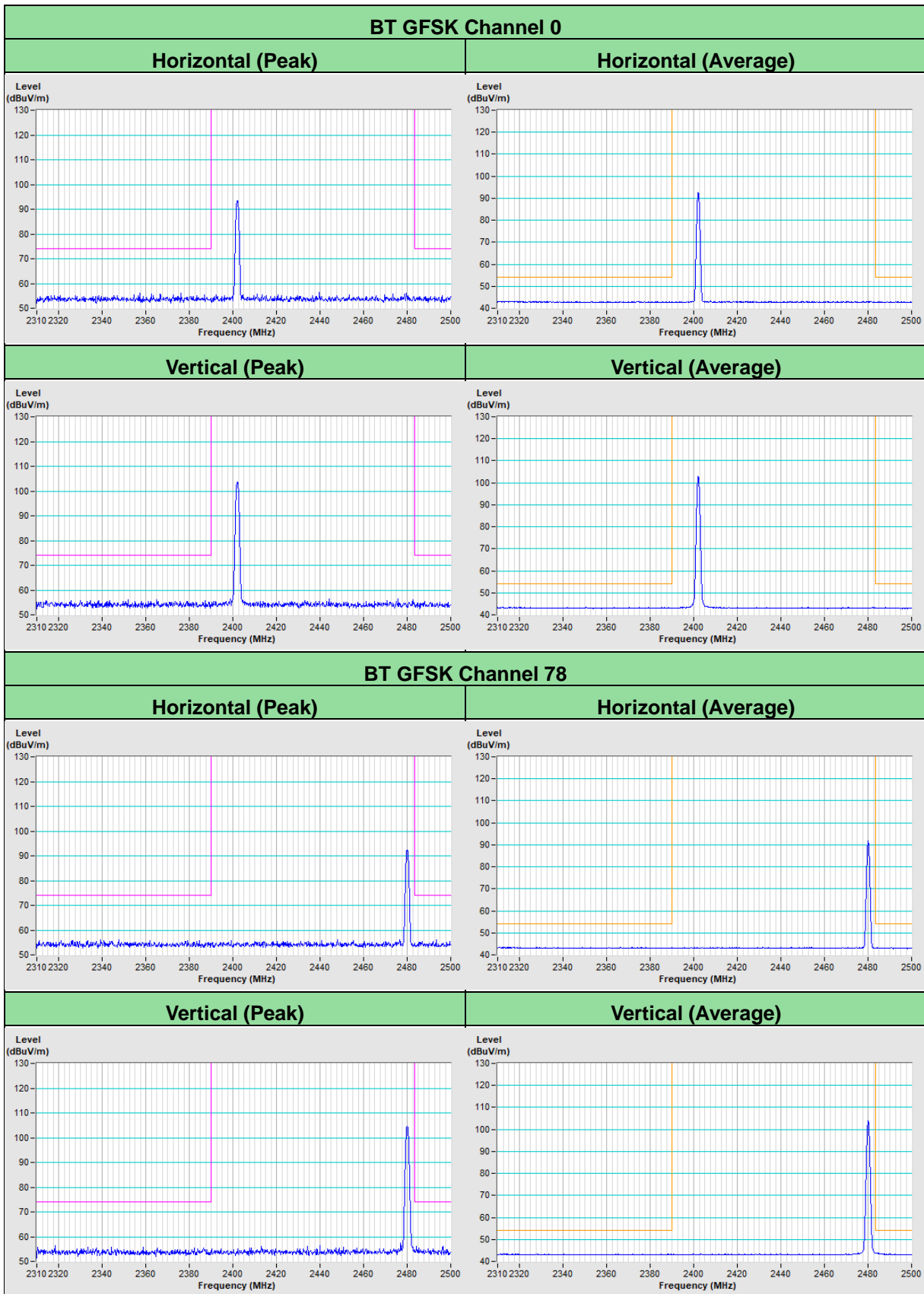

### BT 8DPSK Channel 0

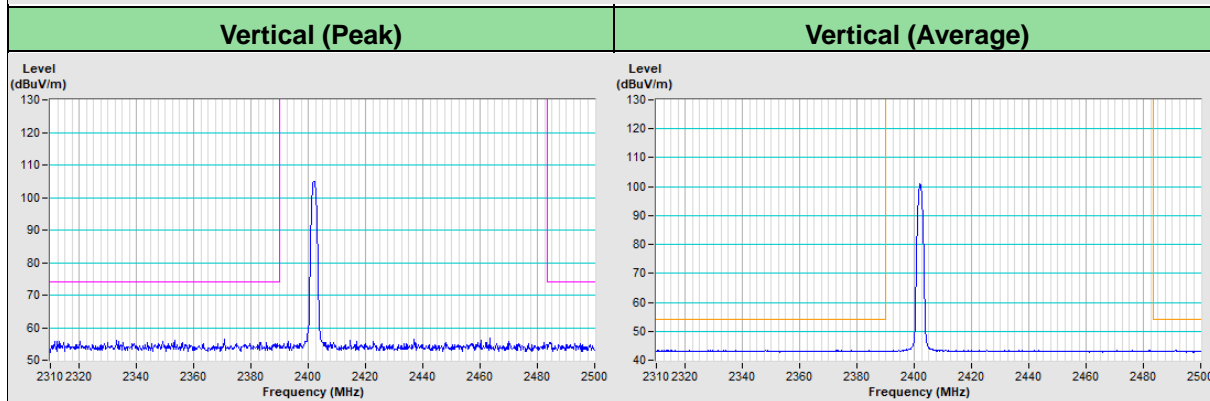
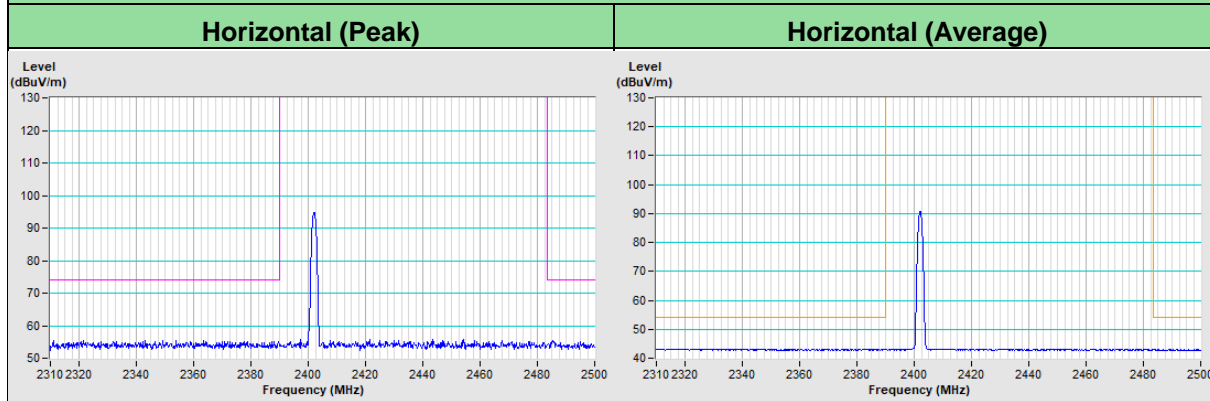

### BT 8DPSK Channel 78

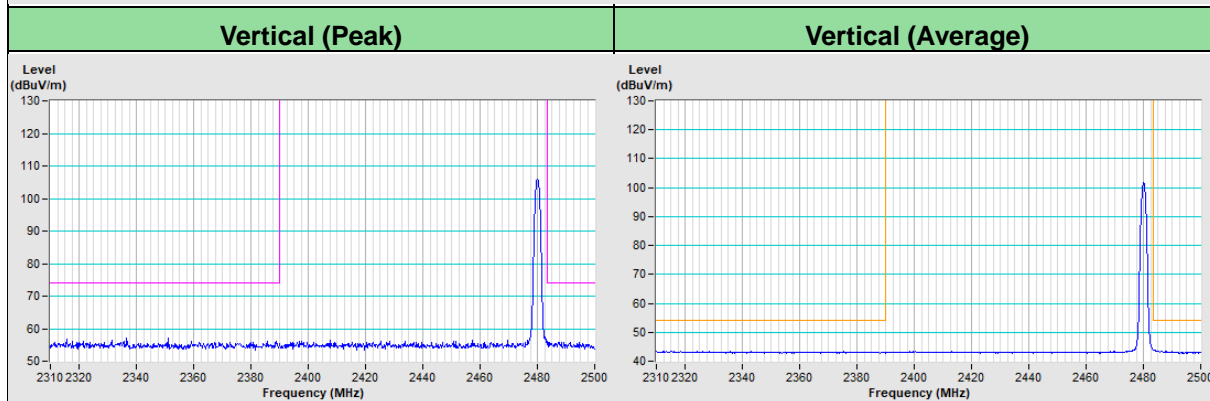
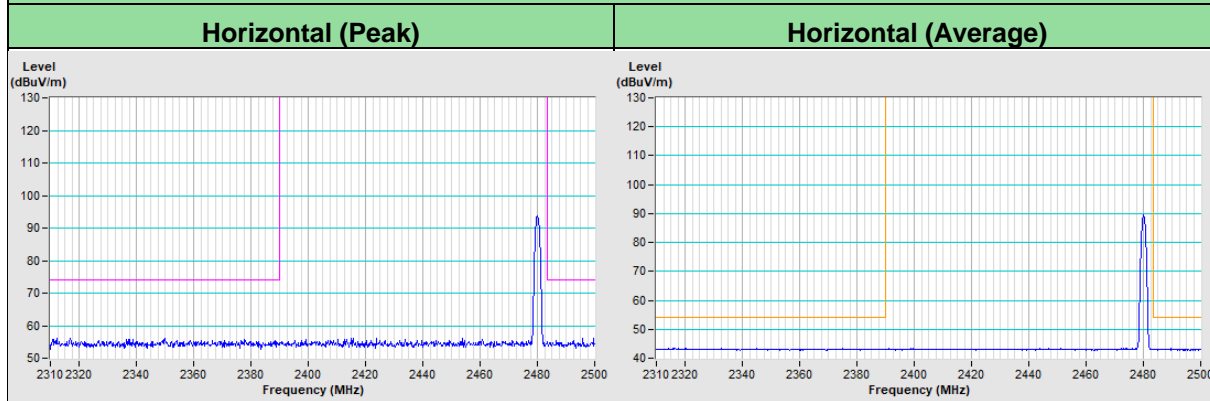

Mode B

RF Mode	TX BT GFSK	Channel	CH 0 : 2402 MHz
Frequency Range	1 GHz ~ 25 GHz	Detector Function & Bandwidth	(PK) RB = 1 MHz, VB = 3 MHz (AV) RB = 1 MHz, VB = 3 MHz
Input Power (System)	120 Vac, 60Hz	Environmental Conditions	25°C, 67% RH
Tested By	Sampson Chen		

Antenna Polarity & Test Distance : Horizontal at 3 m								
No	Frequency (MHz)	Emission Level (dBuV/m)	Limit (dBuV/m)	Margin (dB)	Antenna Height (m)	Table Angle (Degree)	Raw Value (dBuV)	Correction Factor (dB/m)
1	2380.89	55.7 PK	74.0	-18.3	1.25 H	104	58.4	-2.7
2	2380.89	43.3 AV	54.0	-10.7	1.25 H	104	46.0	-2.7
3	*2402.00	99.3 PK			1.25 H	104	102.0	-2.7
4	*2402.00	71.8 AV			1.25 H	104	74.5	-2.7
5	4804.00	37.6 PK	74.0	-36.4	1.48 H	147	36.1	1.5
6	4804.00	10.1 AV	54.0	-43.9	1.48 H	147	8.6	1.5

Remarks:

1. Emission Level(dBuV/m) = Raw Value(dBuV) + Correction Factor(dB/m)
2. Correction Factor(dB/m) = Antenna Factor(dB/m) + Cable Factor(dB) – Pre-Amplifier Factor(dB)
3. Margin value = Emission Level – Limit value
4. The other emission levels were very low against the limit.
5. " \* ": Fundamental frequency, the limit was restricted at the RF Output Power.
6. The average value of fundamental and harmonic frequency is: Average = Peak value + 20 log(Duty cycle) Where the duty cycle correction factor is calculated from following formula:  
 $20 \log(\text{Duty cycle}) = 20 \log(4.2 \text{ ms} / 100 \text{ ms}) = -27.5 \text{ dB}$

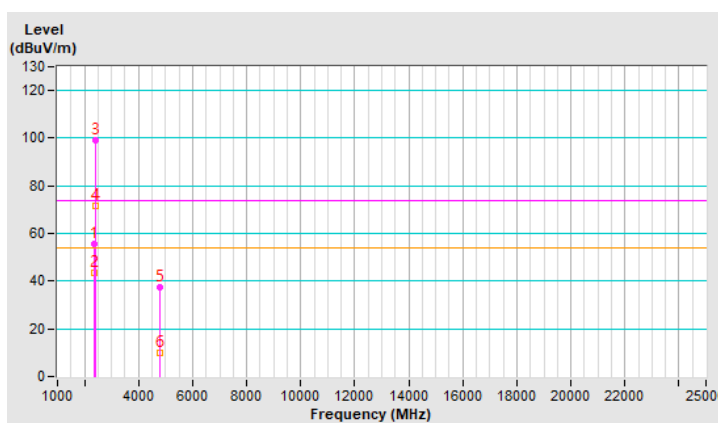

<b>RF Mode</b>	TX BT GFSK	<b>Channel</b>	CH 0 : 2402 MHz
<b>Frequency Range</b>	1 GHz ~ 25 GHz	<b>Detector Function &amp; Bandwidth</b>	(PK) RB = 1 MHz, VB = 3 MHz (AV) RB = 1 MHz, VB = 3 MHz
<b>Input Power (System)</b>	120 Vac, 60Hz	<b>Environmental Conditions</b>	25°C, 67% RH
<b>Tested By</b>	Sampson Chen		

Antenna Polarity & Test Distance : Vertical at 3 m								
No	Frequency (MHz)	Emission Level (dBuV/m)	Limit (dBuV/m)	Margin (dB)	Antenna Height (m)	Table Angle (Degree)	Raw Value (dBuV)	Correction Factor (dB/m)
1	2377.24	55.6 PK	74.0	-18.4	1.56 V	322	58.2	-2.6
2	2377.24	43.5 AV	54.0	-10.5	1.56 V	322	46.1	-2.6
3	*2402.00	109.9 PK			1.56 V	322	112.6	-2.7
4	*2402.00	82.4 AV			1.56 V	322	85.1	-2.7
5	4804.00	43.2 PK	74.0	-30.8	1.19 V	279	41.7	1.5
6	4804.00	15.7 AV	54.0	-38.3	1.19 V	279	14.2	1.5

**Remarks:**

1. Emission Level(dBuV/m) = Raw Value(dBuV) + Correction Factor(dB/m)
2. Correction Factor(dB/m) = Antenna Factor(dB/m) + Cable Factor(dB) – Pre-Amplifier Factor(dB)
3. Margin value = Emission Level – Limit value
4. The other emission levels were very low against the limit.
5. " \* " : Fundamental frequency, the limit was restricted at the RF Output Power.
6. The average value of fundamental and harmonic frequency is: Average = Peak value + 20 log(Duty cycle) Where the duty cycle correction factor is calculated from following formula:  
 $20 \log(\text{Duty cycle}) = 20 \log(4.2 \text{ ms} / 100 \text{ ms}) = -27.5 \text{ dB}$

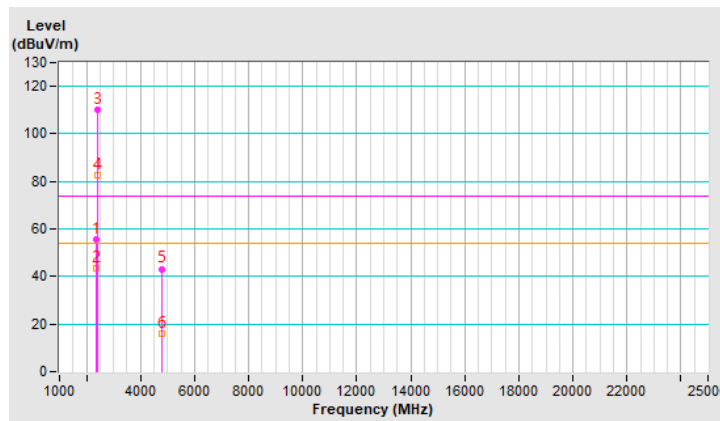



<b>RF Mode</b>	TX BT GFSK	<b>Channel</b>	CH 39 : 2441 MHz
<b>Frequency Range</b>	1 GHz ~ 25 GHz	<b>Detector Function &amp; Bandwidth</b>	(PK) RB = 1 MHz, VB = 3 MHz (AV) RB = 1 MHz, VB = 3 MHz
<b>Input Power (System)</b>	120 Vac, 60Hz	<b>Environmental Conditions</b>	25°C, 67% RH
<b>Tested By</b>	Sampson Chen		

Antenna Polarity & Test Distance : Horizontal at 3 m								
No	Frequency (MHz)	Emission Level (dBuV/m)	Limit (dBuV/m)	Margin (dB)	Antenna Height (m)	Table Angle (Degree)	Raw Value (dBuV)	Correction Factor (dB/m)
1	*2441.00	100.7 PK			1.23 H	111	103.5	-2.8
2	*2441.00	73.2 AV			1.23 H	111	76.0	-2.8
3	4882.00	37.6 PK	74.0	-36.4	1.58 H	133	36.1	1.5
4	4882.00	10.1 AV	54.0	-43.9	1.58 H	133	8.6	1.5
5	7323.00	42.9 PK	74.0	-31.1	1.82 H	189	35.7	7.2
6	7323.00	15.4 AV	54.0	-38.6	1.82 H	189	8.2	7.2

**Remarks:**

1. Emission Level(dBuV/m) = Raw Value(dBuV) + Correction Factor(dB/m)
2. Correction Factor(dB/m) = Antenna Factor(dB/m) + Cable Factor(dB) – Pre-Amplifier Factor(dB)
3. Margin value = Emission Level – Limit value
4. The other emission levels were very low against the limit.
5. " \* " : Fundamental frequency, the limit was restricted at the RF Output Power.
6. The average value of fundamental and harmonic frequency is: Average = Peak value + 20 log(Duty cycle) Where the duty cycle correction factor is calculated from following formula:  
 $20 \log(\text{Duty cycle}) = 20 \log(4.2 \text{ ms} / 100 \text{ ms}) = -27.5 \text{ dB}$

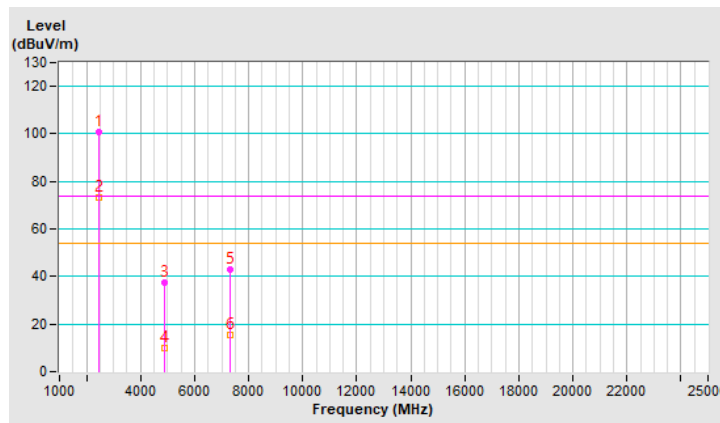

<b>RF Mode</b>	TX BT GFSK	<b>Channel</b>	CH 39 : 2441 MHz
<b>Frequency Range</b>	1 GHz ~ 25 GHz	<b>Detector Function &amp; Bandwidth</b>	(PK) RB = 1 MHz, VB = 3 MHz (AV) RB = 1 MHz, VB = 3 MHz
<b>Input Power (System)</b>	120 Vac, 60Hz	<b>Environmental Conditions</b>	25°C, 67% RH
<b>Tested By</b>	Sampson Chen		

Antenna Polarity & Test Distance : Vertical at 3 m								
No	Frequency (MHz)	Emission Level (dBuV/m)	Limit (dBuV/m)	Margin (dB)	Antenna Height (m)	Table Angle (Degree)	Raw Value (dBuV)	Correction Factor (dB/m)
1	*2441.00	109.8 PK			1.61 V	314	112.6	-2.8
2	*2441.00	82.3 AV			1.61 V	314	85.1	-2.8
3	4882.00	43.9 PK	74.0	-30.1	1.27 V	300	42.4	1.5
4	4882.00	16.4 AV	54.0	-37.6	1.27 V	300	14.9	1.5
5	7323.00	42.2 PK	74.0	-31.8	1.55 V	255	35.0	7.2
6	7323.00	14.7 AV	54.0	-39.3	1.55 V	255	7.5	7.2

**Remarks:**

1. Emission Level(dBuV/m) = Raw Value(dBuV) + Correction Factor(dB/m)
2. Correction Factor(dB/m) = Antenna Factor(dB/m) + Cable Factor(dB) – Pre-Amplifier Factor(dB)
3. Margin value = Emission Level – Limit value
4. The other emission levels were very low against the limit.
5. " \* " : Fundamental frequency, the limit was restricted at the RF Output Power.
6. The average value of fundamental and harmonic frequency is: Average = Peak value + 20 log(Duty cycle) Where the duty cycle correction factor is calculated from following formula:  
 $20 \log(\text{Duty cycle}) = 20 \log(4.2 \text{ ms} / 100 \text{ ms}) = -27.5 \text{ dB}$

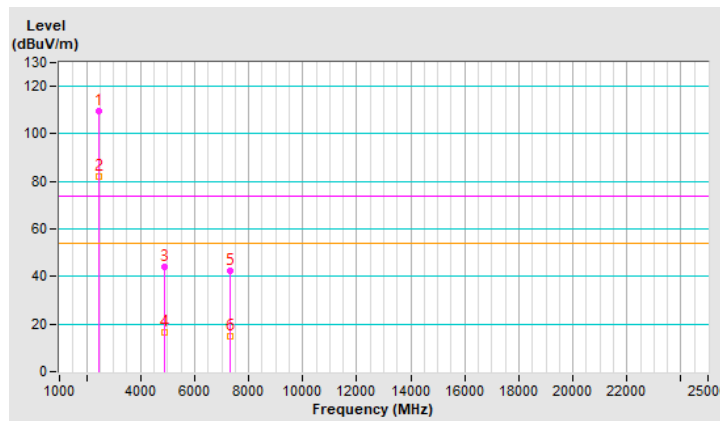

<b>RF Mode</b>	TX BT GFSK	<b>Channel</b>	CH 78 : 2480 MHz
<b>Frequency Range</b>	1 GHz ~ 25 GHz	<b>Detector Function &amp; Bandwidth</b>	(PK) RB = 1 MHz, VB = 3 MHz (AV) RB = 1 MHz, VB = 3 MHz
<b>Input Power (System)</b>	120 Vac, 60Hz	<b>Environmental Conditions</b>	25°C, 67% RH
<b>Tested By</b>	Sampson Chen		

Antenna Polarity & Test Distance : Horizontal at 3 m								
No	Frequency (MHz)	Emission Level (dBuV/m)	Limit (dBuV/m)	Margin (dB)	Antenna Height (m)	Table Angle (Degree)	Raw Value (dBuV)	Correction Factor (dB/m)
1	*2480.00	99.7 PK			1.26 H	104	102.6	-2.9
2	*2480.00	72.2 AV			1.26 H	104	75.1	-2.9
3	2484.57	55.6 PK	74.0	-18.4	1.26 H	104	58.5	-2.9
4	2484.57	43.1 AV	54.0	-10.9	1.26 H	104	46.0	-2.9
5	4960.00	37.3 PK	74.0	-36.7	1.52 H	136	35.6	1.7
6	4960.00	9.8 AV	54.0	-44.2	1.52 H	136	8.1	1.7
7	7440.00	42.2 PK	74.0	-31.8	1.76 H	193	34.6	7.6
8	7440.00	14.7 AV	54.0	-39.3	1.76 H	193	7.1	7.6

**Remarks:**

1. Emission Level(dBuV/m) = Raw Value(dBuV) + Correction Factor(dB/m)
2. Correction Factor(dB/m) = Antenna Factor(dB/m) + Cable Factor(dB) – Pre-Amplifier Factor(dB)
3. Margin value = Emission Level – Limit value
4. The other emission levels were very low against the limit.
5. " \* ": Fundamental frequency, the limit was restricted at the RF Output Power.
6. The average value of fundamental and harmonic frequency is: Average = Peak value + 20 log(Duty cycle) Where the duty cycle correction factor is calculated from following formula:  
 $20 \log(\text{Duty cycle}) = 20 \log(4.2 \text{ ms} / 100 \text{ ms}) = -27.5 \text{ dB}$

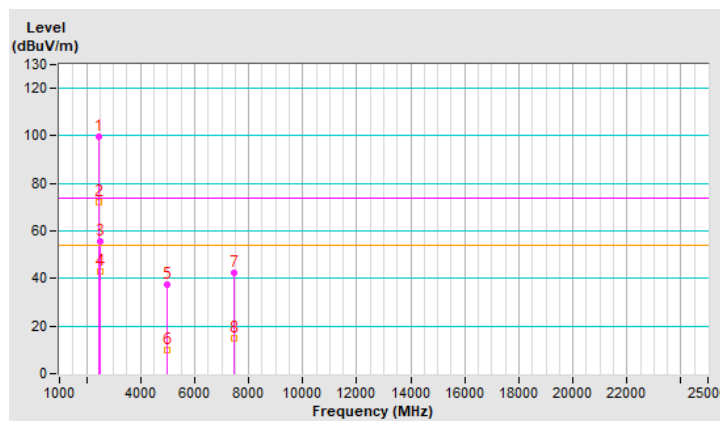

<b>RF Mode</b>	TX BT GFSK	<b>Channel</b>	CH 78 : 2480 MHz
<b>Frequency Range</b>	1 GHz ~ 25 GHz	<b>Detector Function &amp; Bandwidth</b>	(PK) RB = 1 MHz, VB = 3 MHz (AV) RB = 1 MHz, VB = 3 MHz
<b>Input Power (System)</b>	120 Vac, 60Hz	<b>Environmental Conditions</b>	25°C, 67% RH
<b>Tested By</b>	Sampson Chen		

Antenna Polarity & Test Distance : Vertical at 3 m								
No	Frequency (MHz)	Emission Level (dBuV/m)	Limit (dBuV/m)	Margin (dB)	Antenna Height (m)	Table Angle (Degree)	Raw Value (dBuV)	Correction Factor (dB/m)
1	*2480.00	109.2 PK			1.61 V	295	112.1	-2.9
2	*2480.00	81.7 AV			1.61 V	295	84.6	-2.9
3	2483.93	56.7 PK	74.0	-17.3	1.61 V	295	59.6	-2.9
4	2483.93	44.3 AV	54.0	-9.7	1.61 V	295	47.2	-2.9
5	4960.00	43.3 PK	74.0	-30.7	1.25 V	292	41.6	1.7
6	4960.00	15.8 AV	54.0	-38.2	1.25 V	292	14.1	1.7
7	7440.00	42.1 PK	74.0	-31.9	1.55 V	273	34.5	7.6
8	7440.00	14.6 AV	54.0	-39.4	1.55 V	273	7.0	7.6

**Remarks:**

1. Emission Level(dBuV/m) = Raw Value(dBuV) + Correction Factor(dB/m)
2. Correction Factor(dB/m) = Antenna Factor(dB/m) + Cable Factor(dB) – Pre-Amplifier Factor(dB)
3. Margin value = Emission Level – Limit value
4. The other emission levels were very low against the limit.
5. " \* ": Fundamental frequency, the limit was restricted at the RF Output Power.
6. The average value of fundamental and harmonic frequency is: Average = Peak value + 20 log(Duty cycle) Where the duty cycle correction factor is calculated from following formula:  
 $20 \log(\text{Duty cycle}) = 20 \log(4.2 \text{ ms} / 100 \text{ ms}) = -27.5 \text{ dB}$

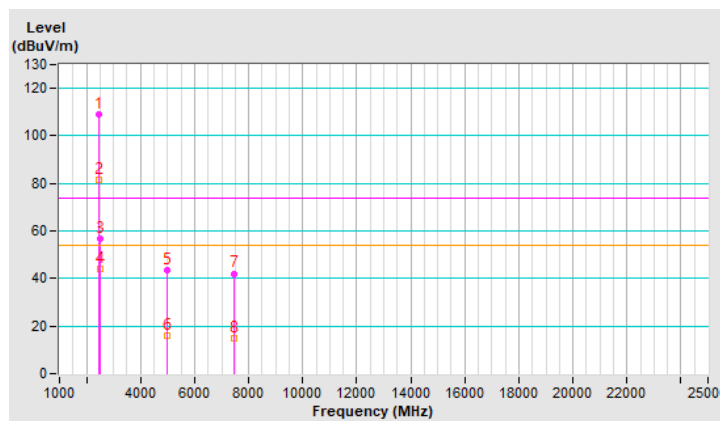

<b>RF Mode</b>	TX BT 8DPSK	<b>Channel</b>	CH 0 : 2402 MHz
<b>Frequency Range</b>	1 GHz ~ 25 GHz	<b>Detector Function &amp; Bandwidth</b>	(PK) RB = 1 MHz, VB = 3 MHz (AV) RB = 1 MHz, VB = 3 MHz
<b>Input Power (System)</b>	120 Vac, 60Hz	<b>Environmental Conditions</b>	25°C, 67% RH
<b>Tested By</b>	Sampson Chen		

Antenna Polarity & Test Distance : Horizontal at 3 m								
No	Frequency (MHz)	Emission Level (dBUV/m)	Limit (dBUV/m)	Margin (dB)	Antenna Height (m)	Table Angle (Degree)	Raw Value (dBUV)	Correction Factor (dB/m)
1	2382.68	55.4 PK	74.0	-18.6	1.43 H	143	58.1	-2.7
2	2382.68	43.2 AV	54.0	-10.8	1.43 H	143	45.9	-2.7
3	*2402.00	100.8 PK			1.43 H	143	103.5	-2.7
4	*2402.00	72.8 AV			1.43 H	143	75.5	-2.7
5	4804.00	38.0 PK	74.0	-36.0	1.62 H	130	36.5	1.5
6	4804.00	10.0 AV	54.0	-44.0	1.62 H	130	8.5	1.5

**Remarks:**

1. Emission Level(dBUV/m) = Raw Value(dBUV) + Correction Factor(dB/m)
2. Correction Factor(dB/m) = Antenna Factor(dB/m) + Cable Factor(dB) – Pre-Amplifier Factor(dB)
3. Margin value = Emission Level – Limit value
4. The other emission levels were very low against the limit.
5. " \* " : Fundamental frequency, the limit was restricted at the RF Output Power.
6. The average value of fundamental and harmonic frequency is: Average = Peak value + 20 log(Duty cycle) Where the duty cycle correction factor is calculated from following formula:  
 $20 \log(\text{Duty cycle}) = 20 \log(4 \text{ ms} / 100 \text{ ms}) = -28.0 \text{ dB}$

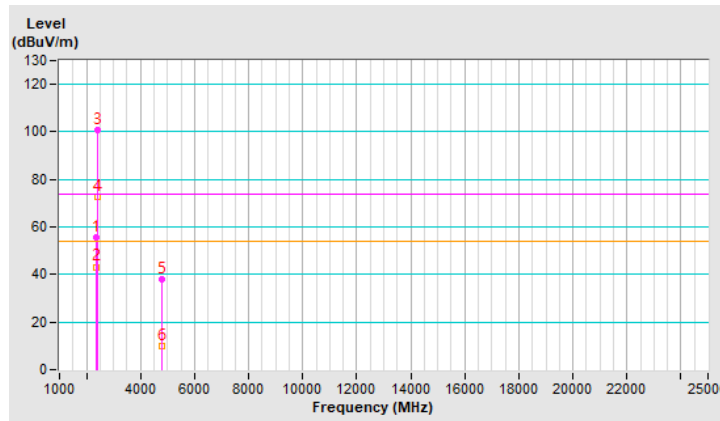

<b>RF Mode</b>	TX BT 8DPSK	<b>Channel</b>	CH 0 : 2402 MHz
<b>Frequency Range</b>	1 GHz ~ 25 GHz	<b>Detector Function &amp; Bandwidth</b>	(PK) RB = 1 MHz, VB = 3 MHz (AV) RB = 1 MHz, VB = 3 MHz
<b>Input Power (System)</b>	120 Vac, 60Hz	<b>Environmental Conditions</b>	25°C, 67% RH
<b>Tested By</b>	Sampson Chen		

Antenna Polarity & Test Distance : Vertical at 3 m								
No	Frequency (MHz)	Emission Level (dBuV/m)	Limit (dBuV/m)	Margin (dB)	Antenna Height (m)	Table Angle (Degree)	Raw Value (dBuV)	Correction Factor (dB/m)
1	2388.91	55.9 PK	74.0	-18.1	1.58 V	230	58.6	-2.7
2	2388.91	43.3 AV	54.0	-10.7	1.58 V	230	46.0	-2.7
3	*2402.00	110.2 PK			1.58 V	230	112.9	-2.7
4	*2402.00	82.2 AV			1.58 V	230	84.9	-2.7
5	4804.00	44.1 PK	74.0	-29.9	1.24 V	315	42.6	1.5
6	4804.00	16.1 AV	54.0	-37.9	1.24 V	315	14.6	1.5

**Remarks:**

1. Emission Level(dBuV/m) = Raw Value(dBuV) + Correction Factor(dB/m)
2. Correction Factor(dB/m) = Antenna Factor(dB/m) + Cable Factor(dB) – Pre-Amplifier Factor(dB)
3. Margin value = Emission Level – Limit value
4. The other emission levels were very low against the limit.
5. " \* " : Fundamental frequency, the limit was restricted at the RF Output Power.
6. The average value of fundamental and harmonic frequency is: Average = Peak value + 20 log(Duty cycle) Where the duty cycle correction factor is calculated from following formula:  
 $20 \log(\text{Duty cycle}) = 20 \log(4 \text{ ms} / 100 \text{ ms}) = -28.0 \text{ dB}$

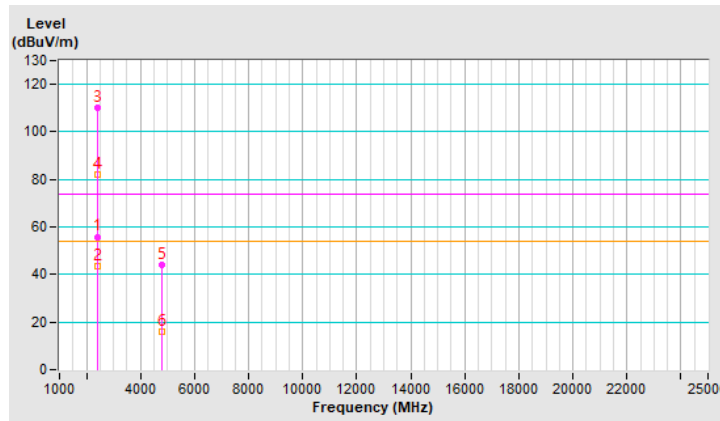

<b>RF Mode</b>	TX BT 8DPSK	<b>Channel</b>	CH 39 : 2441 MHz
<b>Frequency Range</b>	1 GHz ~ 25 GHz	<b>Detector Function &amp; Bandwidth</b>	(PK) RB = 1 MHz, VB = 3 MHz (AV) RB = 1 MHz, VB = 3 MHz
<b>Input Power (System)</b>	120 Vac, 60Hz	<b>Environmental Conditions</b>	25°C, 67% RH
<b>Tested By</b>	Sampson Chen		

Antenna Polarity & Test Distance : Horizontal at 3 m								
No	Frequency (MHz)	Emission Level (dBuV/m)	Limit (dBuV/m)	Margin (dB)	Antenna Height (m)	Table Angle (Degree)	Raw Value (dBuV)	Correction Factor (dB/m)
1	*2441.00	100.1 PK			1.41 H	129	102.9	-2.8
2	*2441.00	72.1 AV			1.41 H	129	74.9	-2.8
3	4882.00	37.5 PK	74.0	-36.5	1.61 H	118	36.0	1.5
4	4882.00	9.5 AV	54.0	-44.5	1.61 H	118	8.0	1.5
5	7323.00	42.8 PK	74.0	-31.2	1.81 H	195	35.6	7.2
6	7323.00	14.8 AV	54.0	-39.2	1.81 H	195	7.6	7.2

**Remarks:**

1. Emission Level(dBuV/m) = Raw Value(dBuV) + Correction Factor(dB/m)
2. Correction Factor(dB/m) = Antenna Factor(dB/m) + Cable Factor(dB) – Pre-Amplifier Factor(dB)
3. Margin value = Emission Level – Limit value
4. The other emission levels were very low against the limit.
5. " \* " : Fundamental frequency, the limit was restricted at the RF Output Power.
6. The average value of fundamental and harmonic frequency is: Average = Peak value + 20 log(Duty cycle) Where the duty cycle correction factor is calculated from following formula:  
 $20 \log(\text{Duty cycle}) = 20 \log(4 \text{ ms} / 100 \text{ ms}) = -28.0 \text{ dB}$

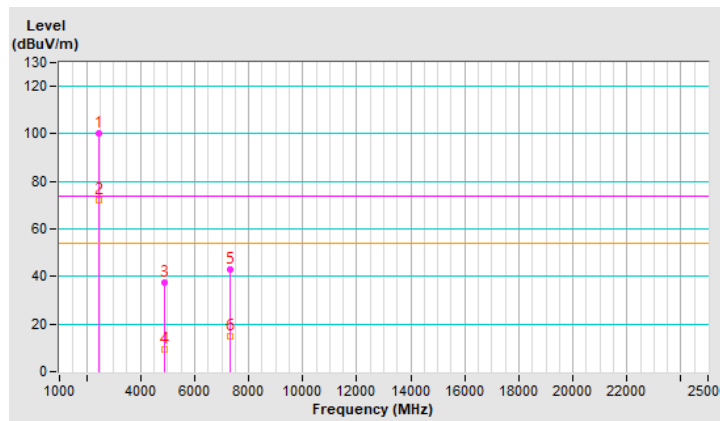

<b>RF Mode</b>	TX BT 8DPSK	<b>Channel</b>	CH 39 : 2441 MHz
<b>Frequency Range</b>	1 GHz ~ 25 GHz	<b>Detector Function &amp; Bandwidth</b>	(PK) RB = 1 MHz, VB = 3 MHz (AV) RB = 1 MHz, VB = 3 MHz
<b>Input Power (System)</b>	120 Vac, 60Hz	<b>Environmental Conditions</b>	25°C, 67% RH
<b>Tested By</b>	Sampson Chen		

Antenna Polarity & Test Distance : Vertical at 3 m								
No	Frequency (MHz)	Emission Level (dBuV/m)	Limit (dBuV/m)	Margin (dB)	Antenna Height (m)	Table Angle (Degree)	Raw Value (dBuV)	Correction Factor (dB/m)
1	*2441.00	109.7 PK			1.60 V	229	112.5	-2.8
2	*2441.00	81.7 AV			1.60 V	229	84.5	-2.8
3	4882.00	43.8 PK	74.0	-30.2	1.28 V	300	42.3	1.5
4	4882.00	15.8 AV	54.0	-38.2	1.28 V	300	14.3	1.5
5	7323.00	42.2 PK	74.0	-31.8	1.56 V	257	35.0	7.2
6	7323.00	14.2 AV	54.0	-39.8	1.56 V	257	7.0	7.2

**Remarks:**

1. Emission Level(dBuV/m) = Raw Value(dBuV) + Correction Factor(dB/m)
2. Correction Factor(dB/m) = Antenna Factor(dB/m) + Cable Factor(dB) – Pre-Amplifier Factor(dB)
3. Margin value = Emission Level – Limit value
4. The other emission levels were very low against the limit.
5. " \* " : Fundamental frequency, the limit was restricted at the RF Output Power.
6. The average value of fundamental and harmonic frequency is: Average = Peak value + 20 log(Duty cycle) Where the duty cycle correction factor is calculated from following formula:  
 $20 \log(\text{Duty cycle}) = 20 \log(4 \text{ ms} / 100 \text{ ms}) = -28.0 \text{ dB}$

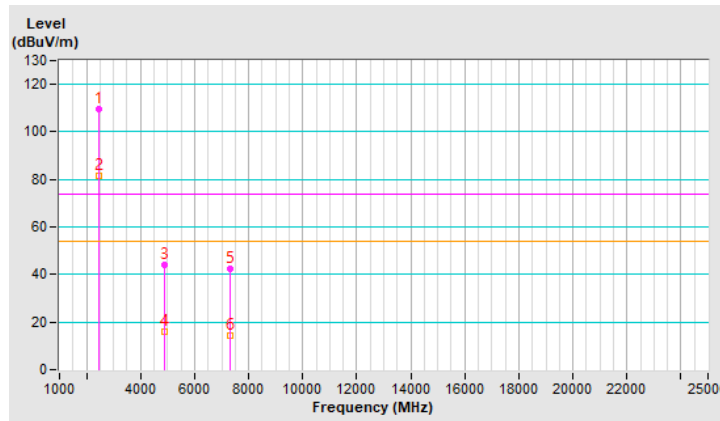



<b>RF Mode</b>	TX BT 8DPSK	<b>Channel</b>	CH 78 : 2480 MHz
<b>Frequency Range</b>	1 GHz ~ 25 GHz	<b>Detector Function &amp; Bandwidth</b>	(PK) RB = 1 MHz, VB = 3 MHz (AV) RB = 1 MHz, VB = 3 MHz
<b>Input Power (System)</b>	120 Vac, 60Hz	<b>Environmental Conditions</b>	25°C, 67% RH
<b>Tested By</b>	Sampson Chen		

Antenna Polarity & Test Distance : Horizontal at 3 m								
No	Frequency (MHz)	Emission Level (dBUV/m)	Limit (dBUV/m)	Margin (dB)	Antenna Height (m)	Table Angle (Degree)	Raw Value (dBUV)	Correction Factor (dB/m)
1	*2480.00	99.7 PK			1.46 H	152	102.6	-2.9
2	*2480.00	71.7 AV			1.46 H	152	74.6	-2.9
3	2487.58	55.6 PK	74.0	-18.4	1.46 H	152	58.5	-2.9
4	2487.58	43.0 AV	54.0	-11.0	1.46 H	152	45.9	-2.9
5	4960.00	37.1 PK	74.0	-36.9	1.53 H	122	35.4	1.7
6	4960.00	9.1 AV	54.0	-44.9	1.53 H	122	7.4	1.7
7	7440.00	43.0 PK	74.0	-31.0	1.80 H	202	35.4	7.6
8	7440.00	15.0 AV	54.0	-39.0	1.80 H	202	7.4	7.6

**Remarks:**

1. Emission Level(dBUV/m) = Raw Value(dBUV) + Correction Factor(dB/m)
2. Correction Factor(dB/m) = Antenna Factor(dB/m) + Cable Factor(dB) – Pre-Amplifier Factor(dB)
3. Margin value = Emission Level – Limit value
4. The other emission levels were very low against the limit.
5. " \* ": Fundamental frequency, the limit was restricted at the RF Output Power.
6. The average value of fundamental and harmonic frequency is: Average = Peak value + 20 log(Duty cycle) Where the duty cycle correction factor is calculated from following formula:  
 $20 \log(\text{Duty cycle}) = 20 \log(4 \text{ ms} / 100 \text{ ms}) = -28.0 \text{ dB}$

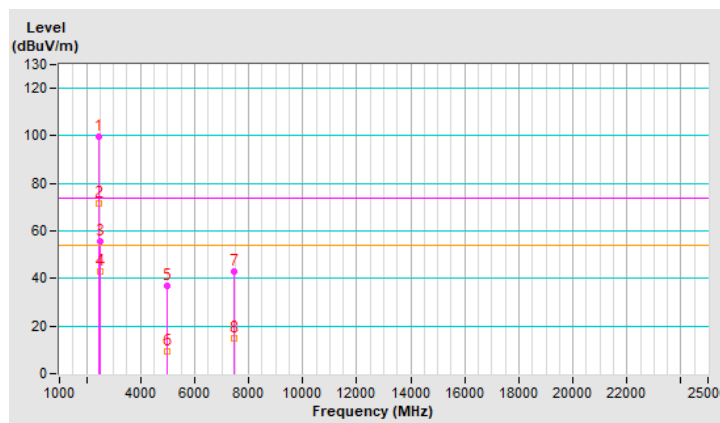

<b>RF Mode</b>	TX BT 8DPSK	<b>Channel</b>	CH 78 : 2480 MHz
<b>Frequency Range</b>	1 GHz ~ 25 GHz	<b>Detector Function &amp; Bandwidth</b>	(PK) RB = 1 MHz, VB = 3 MHz (AV) RB = 1 MHz, VB = 3 MHz
<b>Input Power (System)</b>	120 Vac, 60Hz	<b>Environmental Conditions</b>	25°C, 67% RH
<b>Tested By</b>	Sampson Chen		

Antenna Polarity & Test Distance : Vertical at 3 m								
No	Frequency (MHz)	Emission Level (dBuV/m)	Limit (dBuV/m)	Margin (dB)	Antenna Height (m)	Table Angle (Degree)	Raw Value (dBuV)	Correction Factor (dB/m)
1	*2480.00	109.3 PK			1.54 V	221	112.2	-2.9
2	*2480.00	81.3 AV			1.54 V	221	84.2	-2.9
3	2483.50	55.7 PK	74.0	-18.3	1.54 V	221	58.6	-2.9
<b>4</b>	<b>2483.50</b>	<b>44.4 AV</b>	<b>54.0</b>	<b>-9.6</b>	<b>1.54 V</b>	<b>221</b>	<b>47.3</b>	<b>-2.9</b>
5	4960.00	43.4 PK	74.0	-30.6	1.31 V	312	41.7	1.7
6	4960.00	15.4 AV	54.0	-38.6	1.31 V	312	13.7	1.7
7	7440.00	42.6 PK	74.0	-31.4	1.64 V	288	35.0	7.6
8	7440.00	14.6 AV	54.0	-39.4	1.64 V	288	7.0	7.6

**Remarks:**

1. Emission Level(dBuV/m) = Raw Value(dBuV) + Correction Factor(dB/m)
2. Correction Factor(dB/m) = Antenna Factor(dB/m) + Cable Factor(dB) – Pre-Amplifier Factor(dB)
3. Margin value = Emission Level – Limit value
4. The other emission levels were very low against the limit.
5. " \* ": Fundamental frequency, the limit was restricted at the RF Output Power.
6. The average value of fundamental and harmonic frequency is: Average = Peak value + 20 log(Duty cycle) Where the duty cycle correction factor is calculated from following formula:  
 $20 \log(\text{Duty cycle}) = 20 \log(4 \text{ ms} / 100 \text{ ms}) = -28.0 \text{ dB}$

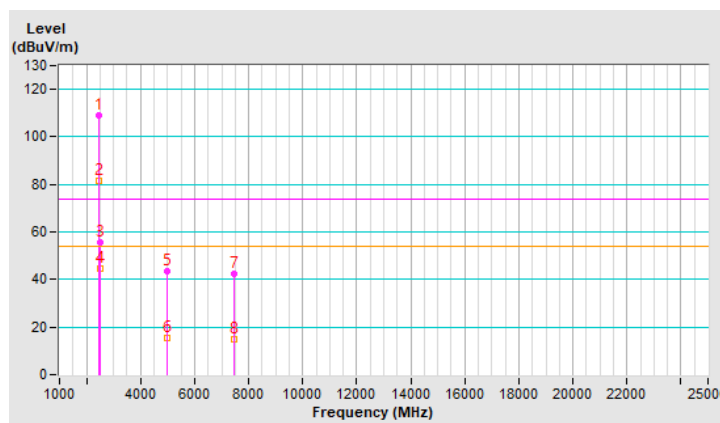

### Mode B\_Plot of Band Edge

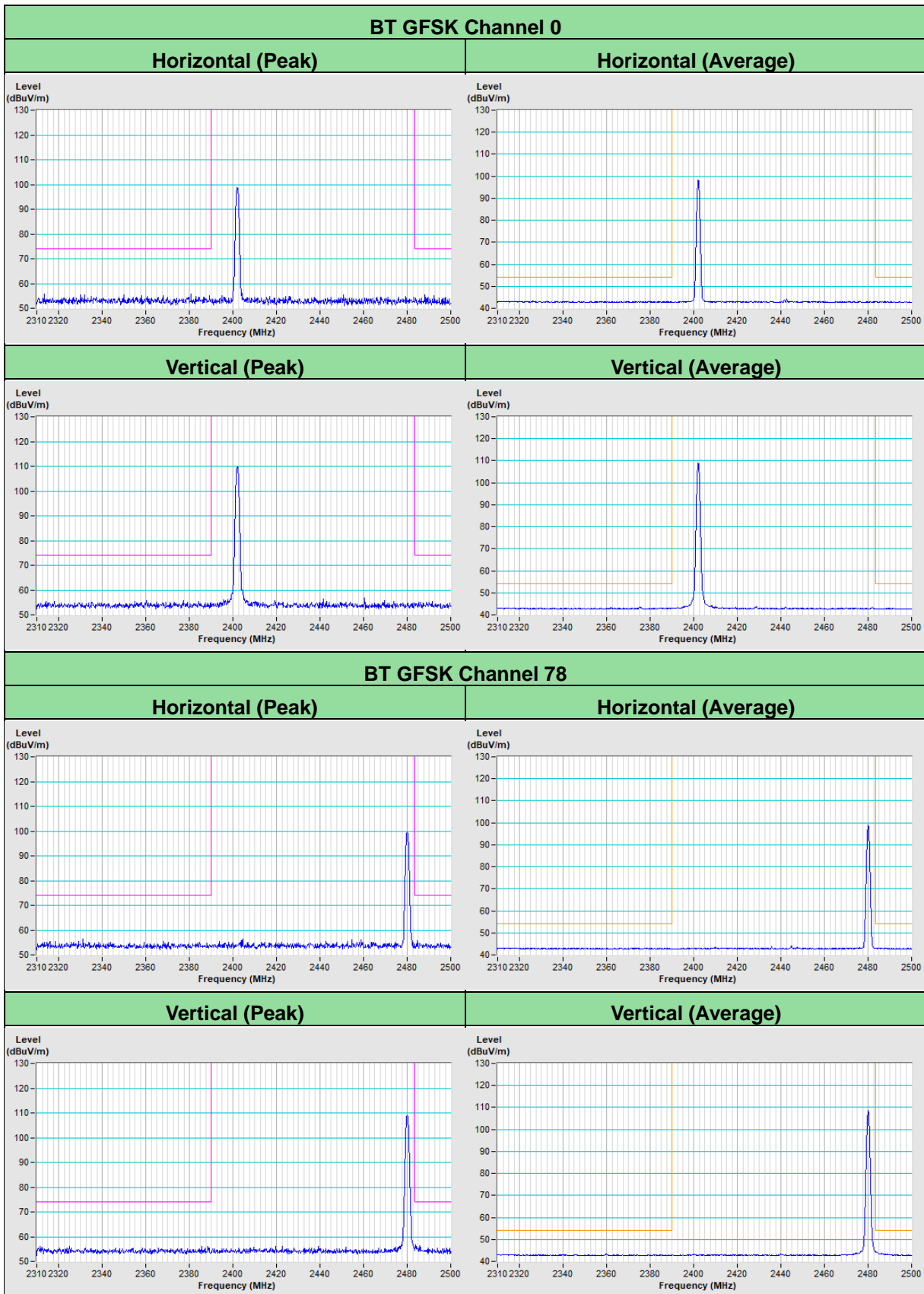

### BT 8DPSK Channel 0

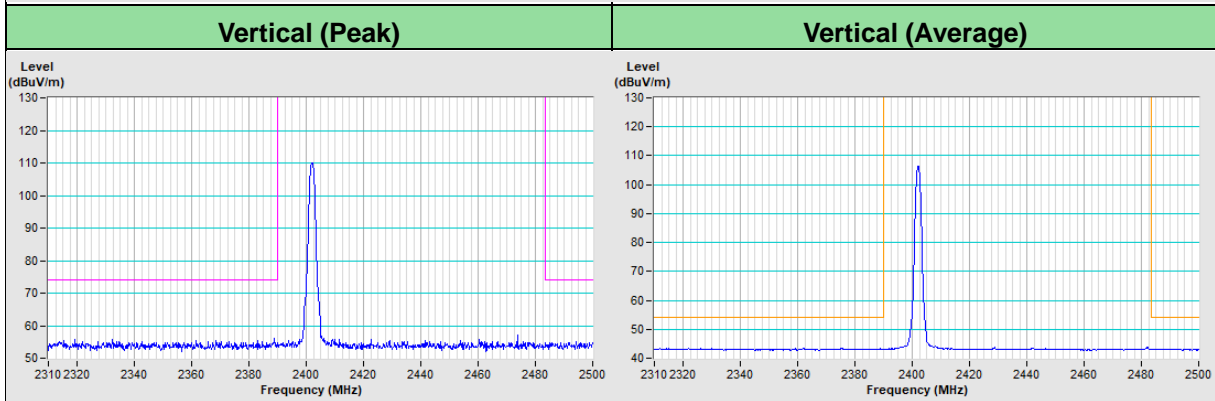
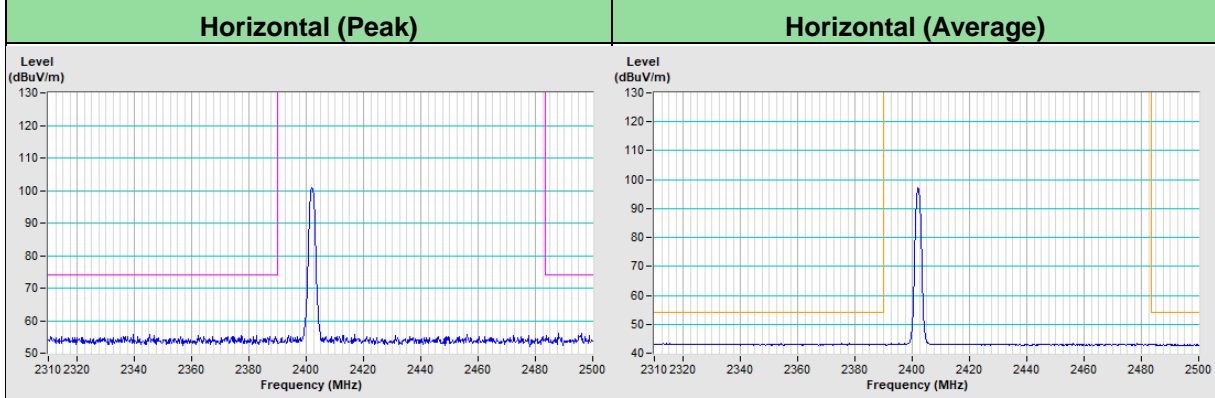

### BT 8DPSK Channel 78

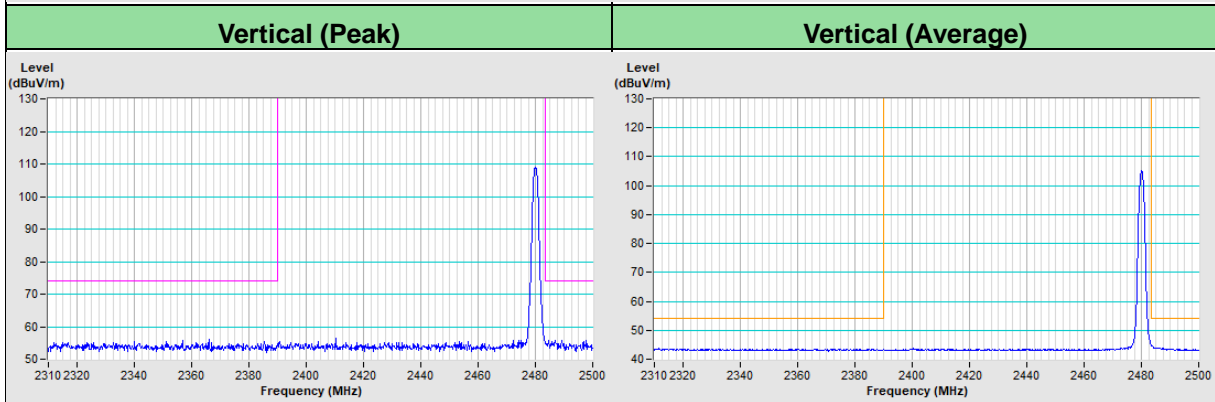
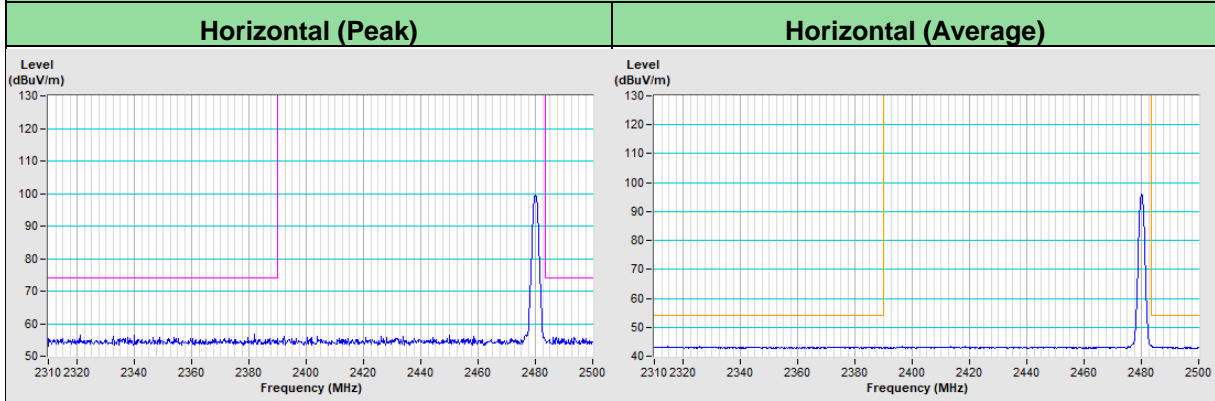

## Mode C

RF Mode	TX BT GFSK	Channel	CH 0 : 2402 MHz
Frequency Range	1 GHz ~ 25 GHz	Detector Function & Bandwidth	(PK) RB = 1 MHz, VB = 3 MHz (AV) RB = 1 MHz, VB = 3 MHz
Input Power (System)	120 Vac, 60Hz	Environmental Conditions	25°C, 67% RH
Tested By	Sampson Chen		

## Antenna Polarity &amp; Test Distance : Horizontal at 3 m

No	Frequency (MHz)	Emission Level (dBuV/m)	Limit (dBuV/m)	Margin (dB)	Antenna Height (m)	Table Angle (Degree)	Raw Value (dBuV)	Correction Factor (dB/m)
1	2385.41	55.5 PK	74.0	-18.5	1.17 H	344	58.2	-2.7
2	2385.41	43.2 AV	54.0	-10.8	1.17 H	344	45.9	-2.7
3	*2402.00	100.7 PK			1.17 H	344	103.4	-2.7
4	*2402.00	73.2 AV			1.17 H	344	75.9	-2.7
5	4804.00	42.2 PK	74.0	-31.8	1.26 H	115	40.7	1.5
6	4804.00	14.7 AV	54.0	-39.3	1.26 H	115	13.2	1.5

## Remarks:

- Emission Level(dBuV/m) = Raw Value(dBuV) + Correction Factor(dB/m)
- Correction Factor(dB/m) = Antenna Factor(dB/m) + Cable Factor(dB) – Pre-Amplifier Factor(dB)
- Margin value = Emission Level – Limit value
- The other emission levels were very low against the limit.
- " \* " : Fundamental frequency, the limit was restricted at the RF Output Power.
- The average value of fundamental and harmonic frequency is: Average = Peak value + 20 log(Duty cycle) Where the duty cycle correction factor is calculated from following formula:  
 $20 \log(\text{Duty cycle}) = 20 \log(4.2 \text{ ms} / 100 \text{ ms}) = -27.5 \text{ dB}$

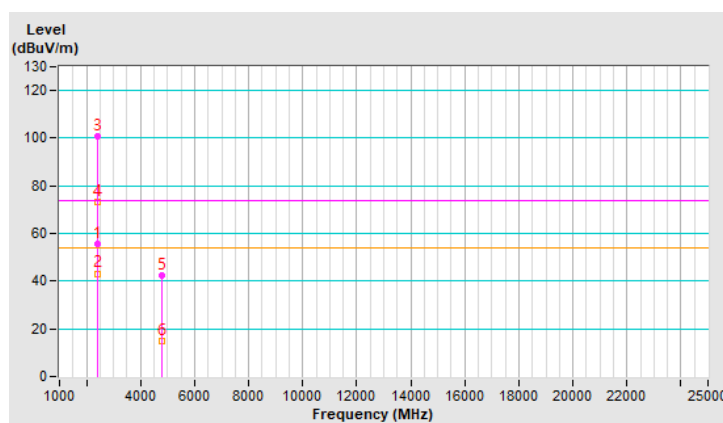

<b>RF Mode</b>	TX BT GFSK	<b>Channel</b>	CH 0 : 2402 MHz
<b>Frequency Range</b>	1 GHz ~ 25 GHz	<b>Detector Function &amp; Bandwidth</b>	(PK) RB = 1 MHz, VB = 3 MHz (AV) RB = 1 MHz, VB = 3 MHz
<b>Input Power (System)</b>	120 Vac, 60Hz	<b>Environmental Conditions</b>	25°C, 67% RH
<b>Tested By</b>	Sampson Chen		

Antenna Polarity & Test Distance : Vertical at 3 m								
No	Frequency (MHz)	Emission Level (dBuV/m)	Limit (dBuV/m)	Margin (dB)	Antenna Height (m)	Table Angle (Degree)	Raw Value (dBuV)	Correction Factor (dB/m)
1	2369.42	55.8 PK	74.0	-18.2	2.29 V	106	58.5	-2.7
2	2369.42	43.2 AV	54.0	-10.8	2.29 V	106	45.9	-2.7
3	*2402.00	98.4 PK			2.29 V	106	101.1	-2.7
4	*2402.00	70.9 AV			2.29 V	106	73.6	-2.7
5	4804.00	39.4 PK	74.0	-34.6	1.07 V	74	37.9	1.5
6	4804.00	11.9 AV	54.0	-42.1	1.07 V	74	10.4	1.5

**Remarks:**

1. Emission Level(dBuV/m) = Raw Value(dBuV) + Correction Factor(dB/m)
2. Correction Factor(dB/m) = Antenna Factor(dB/m) + Cable Factor(dB) – Pre-Amplifier Factor(dB)
3. Margin value = Emission Level – Limit value
4. The other emission levels were very low against the limit.
5. " \* " : Fundamental frequency, the limit was restricted at the RF Output Power.
6. The average value of fundamental and harmonic frequency is: Average = Peak value + 20 log(Duty cycle) Where the duty cycle correction factor is calculated from following formula:  
 $20 \log(\text{Duty cycle}) = 20 \log(4.2 \text{ ms} / 100 \text{ ms}) = -27.5 \text{ dB}$

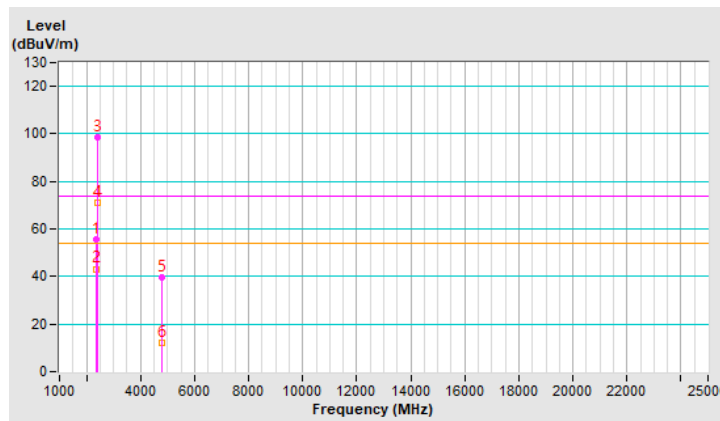

<b>RF Mode</b>	TX BT GFSK	<b>Channel</b>	CH 39 : 2441 MHz
<b>Frequency Range</b>	1 GHz ~ 25 GHz	<b>Detector Function &amp; Bandwidth</b>	(PK) RB = 1 MHz, VB = 3 MHz (AV) RB = 1 MHz, VB = 3 MHz
<b>Input Power (System)</b>	120 Vac, 60Hz	<b>Environmental Conditions</b>	25°C, 67% RH
<b>Tested By</b>	Sampson Chen		

Antenna Polarity & Test Distance : Horizontal at 3 m								
No	Frequency (MHz)	Emission Level (dBuV/m)	Limit (dBuV/m)	Margin (dB)	Antenna Height (m)	Table Angle (Degree)	Raw Value (dBuV)	Correction Factor (dB/m)
1	*2441.00	100.6 PK			1.10 H	338	103.4	-2.8
2	*2441.00	73.1 AV			1.10 H	338	75.9	-2.8
3	4882.00	41.4 PK	74.0	-32.6	1.28 H	129	39.9	1.5
4	4882.00	13.9 AV	54.0	-40.1	1.28 H	129	12.4	1.5
5	7323.00	42.3 PK	74.0	-31.7	1.43 H	5	35.1	7.2
6	7323.00	14.8 AV	54.0	-39.2	1.43 H	5	7.6	7.2

**Remarks:**

1. Emission Level(dBuV/m) = Raw Value(dBuV) + Correction Factor(dB/m)
2. Correction Factor(dB/m) = Antenna Factor(dB/m) + Cable Factor(dB) – Pre-Amplifier Factor(dB)
3. Margin value = Emission Level – Limit value
4. The other emission levels were very low against the limit.
5. " \* " : Fundamental frequency, the limit was restricted at the RF Output Power.
6. The average value of fundamental and harmonic frequency is: Average = Peak value + 20 log(Duty cycle) Where the duty cycle correction factor is calculated from following formula:  
 $20 \log(\text{Duty cycle}) = 20 \log(4.2 \text{ ms} / 100 \text{ ms}) = -27.5 \text{ dB}$

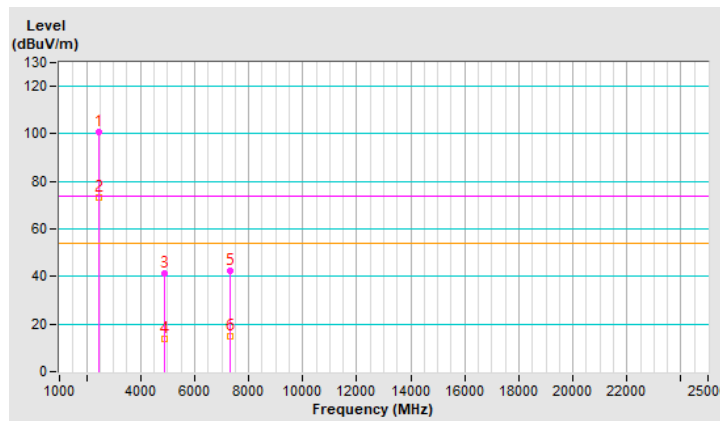

<b>RF Mode</b>	TX BT GFSK	<b>Channel</b>	CH 39 : 2441 MHz
<b>Frequency Range</b>	1 GHz ~ 25 GHz	<b>Detector Function &amp; Bandwidth</b>	(PK) RB = 1 MHz, VB = 3 MHz (AV) RB = 1 MHz, VB = 3 MHz
<b>Input Power (System)</b>	120 Vac, 60Hz	<b>Environmental Conditions</b>	25°C, 67% RH
<b>Tested By</b>	Sampson Chen		

Antenna Polarity & Test Distance : Vertical at 3 m								
No	Frequency (MHz)	Emission Level (dBuV/m)	Limit (dBuV/m)	Margin (dB)	Antenna Height (m)	Table Angle (Degree)	Raw Value (dBuV)	Correction Factor (dB/m)
1	*2441.00	98.6 PK			2.23 V	95	101.4	-2.8
2	*2441.00	71.1 AV			2.23 V	95	73.9	-2.8
3	4882.00	39.8 PK	74.0	-34.2	1.05 V	85	38.3	1.5
4	4882.00	12.3 AV	54.0	-41.7	1.05 V	85	10.8	1.5
5	7323.00	42.4 PK	74.0	-31.6	3.88 V	345	35.2	7.2
6	7323.00	14.9 AV	54.0	-39.1	3.88 V	345	7.7	7.2

**Remarks:**

1. Emission Level(dBuV/m) = Raw Value(dBuV) + Correction Factor(dB/m)
2. Correction Factor(dB/m) = Antenna Factor(dB/m) + Cable Factor(dB) – Pre-Amplifier Factor(dB)
3. Margin value = Emission Level – Limit value
4. The other emission levels were very low against the limit.
5. " \* " : Fundamental frequency, the limit was restricted at the RF Output Power.
6. The average value of fundamental and harmonic frequency is: Average = Peak value + 20 log(Duty cycle) Where the duty cycle correction factor is calculated from following formula:  
 $20 \log(\text{Duty cycle}) = 20 \log(4.2 \text{ ms} / 100 \text{ ms}) = -27.5 \text{ dB}$

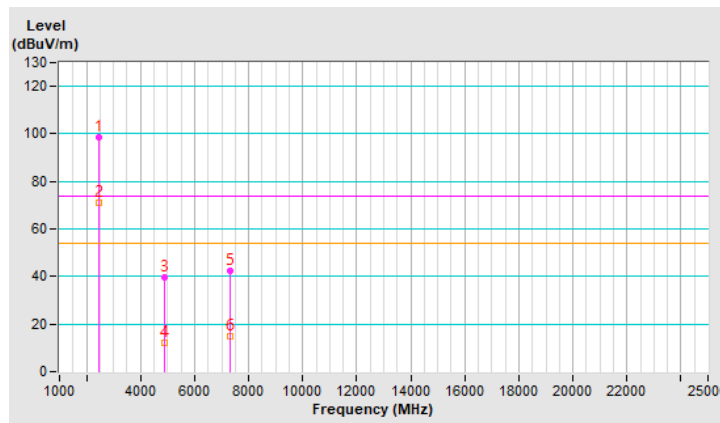



<b>RF Mode</b>	TX BT GFSK	<b>Channel</b>	CH 78 : 2480 MHz
<b>Frequency Range</b>	1 GHz ~ 25 GHz	<b>Detector Function &amp; Bandwidth</b>	(PK) RB = 1 MHz, VB = 3 MHz (AV) RB = 1 MHz, VB = 3 MHz
<b>Input Power (System)</b>	120 Vac, 60Hz	<b>Environmental Conditions</b>	25°C, 67% RH
<b>Tested By</b>	Sampson Chen		

Antenna Polarity & Test Distance : Horizontal at 3 m								
No	Frequency (MHz)	Emission Level (dBuV/m)	Limit (dBuV/m)	Margin (dB)	Antenna Height (m)	Table Angle (Degree)	Raw Value (dBuV)	Correction Factor (dB/m)
1	*2480.00	100.2 PK			1.19 H	360	103.1	-2.9
2	*2480.00	72.7 AV			1.19 H	360	75.6	-2.9
3	2487.68	55.5 PK	74.0	-18.5	1.19 H	360	58.4	-2.9
4	2487.68	43.4 AV	54.0	-10.6	1.19 H	360	46.3	-2.9
5	4960.00	41.5 PK	74.0	-32.5	1.31 H	150	39.8	1.7
6	4960.00	14.0 AV	54.0	-40.0	1.31 H	150	12.3	1.7
7	7440.00	42.8 PK	74.0	-31.2	1.54 H	20	35.2	7.6
8	7440.00	15.3 AV	54.0	-38.7	1.54 H	20	7.7	7.6

**Remarks:**

1. Emission Level(dBuV/m) = Raw Value(dBuV) + Correction Factor(dB/m)
2. Correction Factor(dB/m) = Antenna Factor(dB/m) + Cable Factor(dB) – Pre-Amplifier Factor(dB)
3. Margin value = Emission Level – Limit value
4. The other emission levels were very low against the limit.
5. " \* ": Fundamental frequency, the limit was restricted at the RF Output Power.
6. The average value of fundamental and harmonic frequency is: Average = Peak value + 20 log(Duty cycle) Where the duty cycle correction factor is calculated from following formula:  
 $20 \log(\text{Duty cycle}) = 20 \log(4.2 \text{ ms} / 100 \text{ ms}) = -27.5 \text{ dB}$

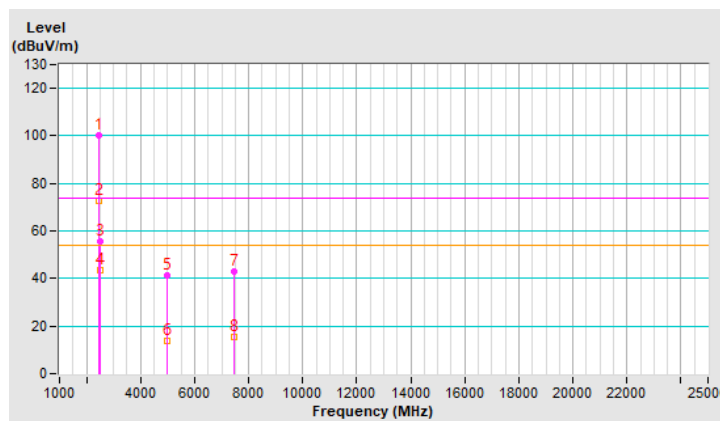

<b>RF Mode</b>	TX BT GFSK	<b>Channel</b>	CH 78 : 2480 MHz
<b>Frequency Range</b>	1 GHz ~ 25 GHz	<b>Detector Function &amp; Bandwidth</b>	(PK) RB = 1 MHz, VB = 3 MHz (AV) RB = 1 MHz, VB = 3 MHz
<b>Input Power (System)</b>	120 Vac, 60Hz	<b>Environmental Conditions</b>	25°C, 67% RH
<b>Tested By</b>	Sampson Chen		

Antenna Polarity & Test Distance : Vertical at 3 m								
No	Frequency (MHz)	Emission Level (dBuV/m)	Limit (dBuV/m)	Margin (dB)	Antenna Height (m)	Table Angle (Degree)	Raw Value (dBuV)	Correction Factor (dB/m)
1	#2394.86	54.9 PK			2.22 V	95	57.6	-2.7
2	#2394.86	43.2 AV			2.22 V	95	45.9	-2.7
3	*2480.00	98.0 PK			2.22 V	95	100.9	-2.9
4	*2480.00	70.5 AV			2.22 V	95	73.4	-2.9
5	4960.00	39.9 PK	74.0	-34.1	1.06 V	97	38.2	1.7
6	4960.00	12.4 AV	54.0	-41.6	1.06 V	97	10.7	1.7
7	7440.00	42.5 PK	74.0	-31.5	3.88 V	336	34.9	7.6
8	7440.00	15.0 AV	54.0	-39.0	3.88 V	336	7.4	7.6

**Remarks:**

- Emission Level(dBuV/m) = Raw Value(dBuV) + Correction Factor(dB/m)
- Correction Factor(dB/m) = Antenna Factor(dB/m) + Cable Factor(dB) – Pre-Amplifier Factor(dB)
- Margin value = Emission Level – Limit value
- The other emission levels were very low against the limit.
- " \* ": Fundamental frequency, the limit was restricted at the RF Output Power.
- " # ": The radiated frequency is out of the restricted band, the limit was restricted at the Conducted Out of Band Emissions.
- The average value of fundamental and harmonic frequency is: Average = Peak value + 20 log(Duty cycle) Where the duty cycle correction factor is calculated from following formula:  
 $20 \log(\text{Duty cycle}) = 20 \log(4.2 \text{ ms} / 100 \text{ ms}) = -27.5 \text{ dB}$

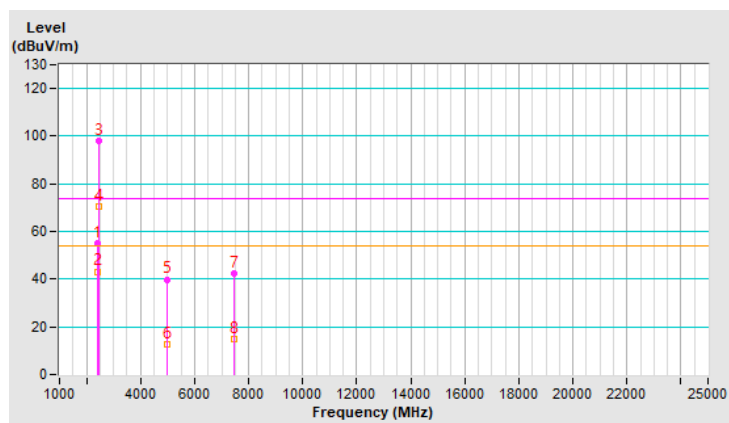

<b>RF Mode</b>	TX BT 8DPSK	<b>Channel</b>	CH 0 : 2402 MHz
<b>Frequency Range</b>	1 GHz ~ 25 GHz	<b>Detector Function &amp; Bandwidth</b>	(PK) RB = 1 MHz, VB = 3 MHz (AV) RB = 1 MHz, VB = 3 MHz
<b>Input Power (System)</b>	120 Vac, 60Hz	<b>Environmental Conditions</b>	25°C, 67% RH
<b>Tested By</b>	Sampson Chen		

Antenna Polarity & Test Distance : Horizontal at 3 m								
No	Frequency (MHz)	Emission Level (dBuV/m)	Limit (dBuV/m)	Margin (dB)	Antenna Height (m)	Table Angle (Degree)	Raw Value (dBuV)	Correction Factor (dB/m)
1	2384.57	55.5 PK	74.0	-18.5	1.21 H	346	58.2	-2.7
2	2384.57	43.0 AV	54.0	-11.0	1.21 H	346	45.7	-2.7
3	*2402.00	102.0 PK			1.21 H	346	104.7	-2.7
4	*2402.00	74.0 AV			1.21 H	346	76.7	-2.7
5	4804.00	41.2 PK	74.0	-32.8	1.30 H	127	39.7	1.5
6	4804.00	13.2 AV	54.0	-40.8	1.30 H	127	11.7	1.5

**Remarks:**

1. Emission Level(dBuV/m) = Raw Value(dBuV) + Correction Factor(dB/m)
2. Correction Factor(dB/m) = Antenna Factor(dB/m) + Cable Factor(dB) – Pre-Amplifier Factor(dB)
3. Margin value = Emission Level – Limit value
4. The other emission levels were very low against the limit.
5. " \* " : Fundamental frequency, the limit was restricted at the RF Output Power.
6. The average value of fundamental and harmonic frequency is: Average = Peak value + 20 log(Duty cycle) Where the duty cycle correction factor is calculated from following formula:  
 $20 \log(\text{Duty cycle}) = 20 \log(4 \text{ ms} / 100 \text{ ms}) = -28.0 \text{ dB}$

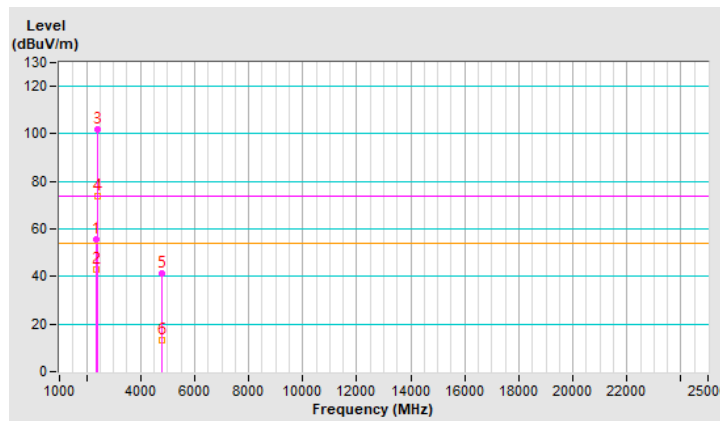

<b>RF Mode</b>	TX BT 8DPSK	<b>Channel</b>	CH 0 : 2402 MHz
<b>Frequency Range</b>	1 GHz ~ 25 GHz	<b>Detector Function &amp; Bandwidth</b>	(PK) RB = 1 MHz, VB = 3 MHz (AV) RB = 1 MHz, VB = 3 MHz
<b>Input Power (System)</b>	120 Vac, 60Hz	<b>Environmental Conditions</b>	25°C, 67% RH
<b>Tested By</b>	Sampson Chen		

Antenna Polarity & Test Distance : Vertical at 3 m								
No	Frequency (MHz)	Emission Level (dBuV/m)	Limit (dBuV/m)	Margin (dB)	Antenna Height (m)	Table Angle (Degree)	Raw Value (dBuV)	Correction Factor (dB/m)
1	2383.37	56.3 PK	74.0	-17.7	2.26 V	93	59.0	-2.7
2	2383.37	43.2 AV	54.0	-10.8	2.26 V	93	45.9	-2.7
3	*2402.00	99.9 PK			2.26 V	93	102.6	-2.7
4	*2402.00	71.9 AV			2.26 V	93	74.6	-2.7
5	4804.00	40.1 PK	74.0	-33.9	1.05 V	88	38.6	1.5
6	4804.00	12.1 AV	54.0	-41.9	1.05 V	88	10.6	1.5

**Remarks:**

1. Emission Level(dBuV/m) = Raw Value(dBuV) + Correction Factor(dB/m)
2. Correction Factor(dB/m) = Antenna Factor(dB/m) + Cable Factor(dB) – Pre-Amplifier Factor(dB)
3. Margin value = Emission Level – Limit value
4. The other emission levels were very low against the limit.
5. " \* " : Fundamental frequency, the limit was restricted at the RF Output Power.
6. The average value of fundamental and harmonic frequency is: Average = Peak value + 20 log(Duty cycle) Where the duty cycle correction factor is calculated from following formula:  
 $20 \log(\text{Duty cycle}) = 20 \log(4 \text{ ms} / 100 \text{ ms}) = -28.0 \text{ dB}$

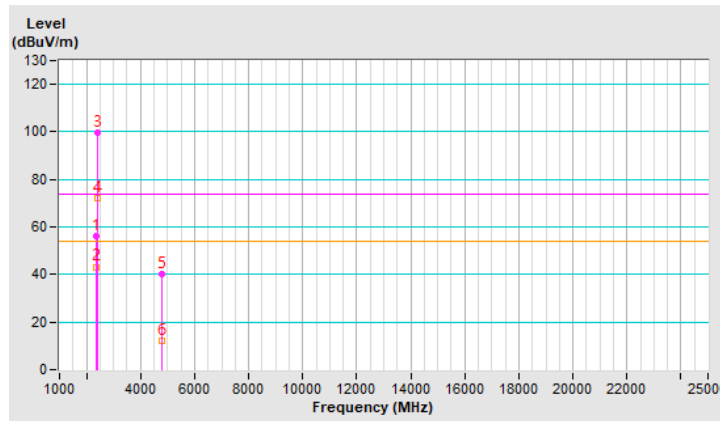

<b>RF Mode</b>	TX BT 8DPSK	<b>Channel</b>	CH 39 : 2441 MHz
<b>Frequency Range</b>	1 GHz ~ 25 GHz	<b>Detector Function &amp; Bandwidth</b>	(PK) RB = 1 MHz, VB = 3 MHz (AV) RB = 1 MHz, VB = 3 MHz
<b>Input Power (System)</b>	120 Vac, 60Hz	<b>Environmental Conditions</b>	25°C, 67% RH
<b>Tested By</b>	Sampson Chen		

Antenna Polarity & Test Distance : Horizontal at 3 m								
No	Frequency (MHz)	Emission Level (dBuV/m)	Limit (dBuV/m)	Margin (dB)	Antenna Height (m)	Table Angle (Degree)	Raw Value (dBuV)	Correction Factor (dB/m)
1	*2441.00	101.5 PK			1.16 H	344	104.3	-2.8
2	*2441.00	73.5 AV			1.16 H	344	76.3	-2.8
3	4882.00	40.8 PK	74.0	-33.2	1.39 H	156	39.3	1.5
4	4882.00	12.8 AV	54.0	-41.2	1.39 H	156	11.3	1.5
5	7323.00	42.5 PK	74.0	-31.5	1.47 H	1	35.3	7.2
6	7323.00	14.5 AV	54.0	-39.5	1.47 H	1	7.3	7.2

**Remarks:**

1. Emission Level(dBuV/m) = Raw Value(dBuV) + Correction Factor(dB/m)
2. Correction Factor(dB/m) = Antenna Factor(dB/m) + Cable Factor(dB) – Pre-Amplifier Factor(dB)
3. Margin value = Emission Level – Limit value
4. The other emission levels were very low against the limit.
5. " \* " : Fundamental frequency, the limit was restricted at the RF Output Power.
6. The average value of fundamental and harmonic frequency is: Average = Peak value + 20 log(Duty cycle) Where the duty cycle correction factor is calculated from following formula:  
 $20 \log(\text{Duty cycle}) = 20 \log(4 \text{ ms} / 100 \text{ ms}) = -28.0 \text{ dB}$

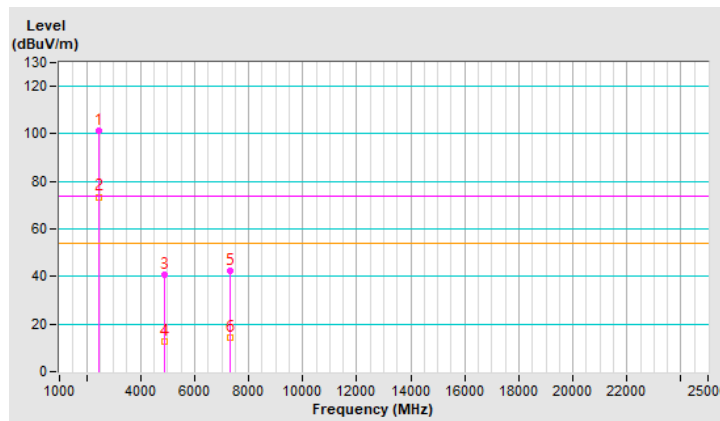

<b>RF Mode</b>	TX BT 8DPSK	<b>Channel</b>	CH 39 : 2441 MHz
<b>Frequency Range</b>	1 GHz ~ 25 GHz	<b>Detector Function &amp; Bandwidth</b>	(PK) RB = 1 MHz, VB = 3 MHz (AV) RB = 1 MHz, VB = 3 MHz
<b>Input Power (System)</b>	120 Vac, 60Hz	<b>Environmental Conditions</b>	25°C, 67% RH
<b>Tested By</b>	Sampson Chen		

Antenna Polarity & Test Distance : Vertical at 3 m								
No	Frequency (MHz)	Emission Level (dBuV/m)	Limit (dBuV/m)	Margin (dB)	Antenna Height (m)	Table Angle (Degree)	Raw Value (dBuV)	Correction Factor (dB/m)
1	*2441.00	100.1 PK			2.21 V	101	102.9	-2.8
2	*2441.00	72.1 AV			2.21 V	101	74.9	-2.8
3	4882.00	40.1 PK	74.0	-33.9	1.00 V	99	38.6	1.5
4	4882.00	12.1 AV	54.0	-41.9	1.00 V	99	10.6	1.5
5	7323.00	42.2 PK	74.0	-31.8	3.90 V	322	35.0	7.2
6	7323.00	14.2 AV	54.0	-39.8	3.90 V	322	7.0	7.2

**Remarks:**

1. Emission Level(dBuV/m) = Raw Value(dBuV) + Correction Factor(dB/m)
2. Correction Factor(dB/m) = Antenna Factor(dB/m) + Cable Factor(dB) – Pre-Amplifier Factor(dB)
3. Margin value = Emission Level – Limit value
4. The other emission levels were very low against the limit.
5. " \* " : Fundamental frequency, the limit was restricted at the RF Output Power.
6. The average value of fundamental and harmonic frequency is: Average = Peak value + 20 log(Duty cycle) Where the duty cycle correction factor is calculated from following formula:  
 $20 \log(\text{Duty cycle}) = 20 \log(4 \text{ ms} / 100 \text{ ms}) = -28.0 \text{ dB}$

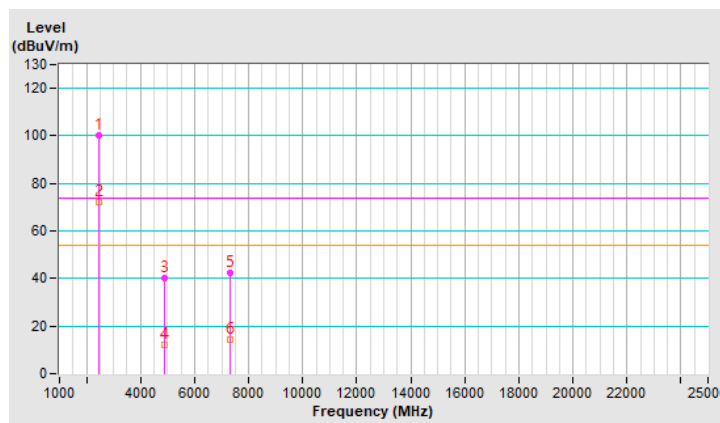

<b>RF Mode</b>	TX BT 8DPSK	<b>Channel</b>	CH 78 : 2480 MHz
<b>Frequency Range</b>	1 GHz ~ 25 GHz	<b>Detector Function &amp; Bandwidth</b>	(PK) RB = 1 MHz, VB = 3 MHz (AV) RB = 1 MHz, VB = 3 MHz
<b>Input Power (System)</b>	120 Vac, 60Hz	<b>Environmental Conditions</b>	25°C, 67% RH
<b>Tested By</b>	Sampson Chen		

Antenna Polarity & Test Distance : Horizontal at 3 m								
No	Frequency (MHz)	Emission Level (dBuV/m)	Limit (dBuV/m)	Margin (dB)	Antenna Height (m)	Table Angle (Degree)	Raw Value (dBuV)	Correction Factor (dB/m)
1	*2480.00	101.4 PK			1.16 H	350	104.3	-2.9
2	*2480.00	73.4 AV			1.16 H	350	76.3	-2.9
3	2486.96	54.7 PK	74.0	-19.3	1.16 H	350	57.6	-2.9
4	2486.96	43.2 AV	54.0	-10.8	1.16 H	350	46.1	-2.9
5	4960.00	41.1 PK	74.0	-32.9	1.33 H	143	39.4	1.7
6	4960.00	13.1 AV	54.0	-40.9	1.33 H	143	11.4	1.7
7	7440.00	42.7 PK	74.0	-31.3	1.48 H	6	35.1	7.6
8	7440.00	14.7 AV	54.0	-39.3	1.48 H	6	7.1	7.6

**Remarks:**

1. Emission Level(dBuV/m) = Raw Value(dBuV) + Correction Factor(dB/m)
2. Correction Factor(dB/m) = Antenna Factor(dB/m) + Cable Factor(dB) – Pre-Amplifier Factor(dB)
3. Margin value = Emission Level – Limit value
4. The other emission levels were very low against the limit.
5. " \* ": Fundamental frequency, the limit was restricted at the RF Output Power.
6. The average value of fundamental and harmonic frequency is: Average = Peak value + 20 log(Duty cycle) Where the duty cycle correction factor is calculated from following formula:  
 $20 \log(\text{Duty cycle}) = 20 \log(4 \text{ ms} / 100 \text{ ms}) = -28.0 \text{ dB}$

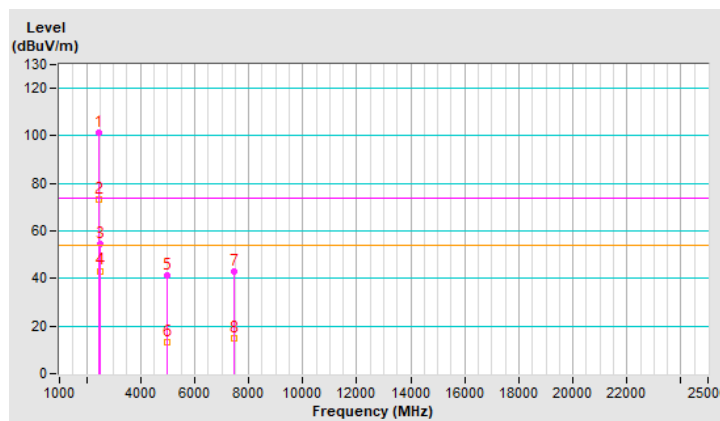

<b>RF Mode</b>	TX BT 8DPSK	<b>Channel</b>	CH 78 : 2480 MHz
<b>Frequency Range</b>	1 GHz ~ 25 GHz	<b>Detector Function &amp; Bandwidth</b>	(PK) RB = 1 MHz, VB = 3 MHz (AV) RB = 1 MHz, VB = 3 MHz
<b>Input Power (System)</b>	120 Vac, 60Hz	<b>Environmental Conditions</b>	25°C, 67% RH
<b>Tested By</b>	Sampson Chen		

Antenna Polarity & Test Distance : Vertical at 3 m								
No	Frequency (MHz)	Emission Level (dBuV/m)	Limit (dBuV/m)	Margin (dB)	Antenna Height (m)	Table Angle (Degree)	Raw Value (dBuV)	Correction Factor (dB/m)
1	*2480.00	99.7 PK			2.25 V	109	102.6	-2.9
2	*2480.00	71.7 AV			2.25 V	109	74.6	-2.9
3	2484.03	55.4 PK	74.0	-18.6	2.25 V	109	58.3	-2.9
4	2484.03	43.2 AV	54.0	-10.8	2.25 V	109	46.1	-2.9
5	4960.00	39.8 PK	74.0	-34.2	1.04 V	85	38.1	1.7
6	4960.00	11.8 AV	54.0	-42.2	1.04 V	85	10.1	1.7
7	7440.00	42.1 PK	74.0	-31.9	3.85 V	338	34.5	7.6
8	7440.00	14.1 AV	54.0	-39.9	3.85 V	338	6.5	7.6

**Remarks:**

1. Emission Level(dBuV/m) = Raw Value(dBuV) + Correction Factor(dB/m)
2. Correction Factor(dB/m) = Antenna Factor(dB/m) + Cable Factor(dB) – Pre-Amplifier Factor(dB)
3. Margin value = Emission Level – Limit value
4. The other emission levels were very low against the limit.
5. " \* ": Fundamental frequency, the limit was restricted at the RF Output Power.
6. The average value of fundamental and harmonic frequency is: Average = Peak value + 20 log(Duty cycle) Where the duty cycle correction factor is calculated from following formula:  
 $20 \log(\text{Duty cycle}) = 20 \log(4 \text{ ms} / 100 \text{ ms}) = -28.0 \text{ dB}$

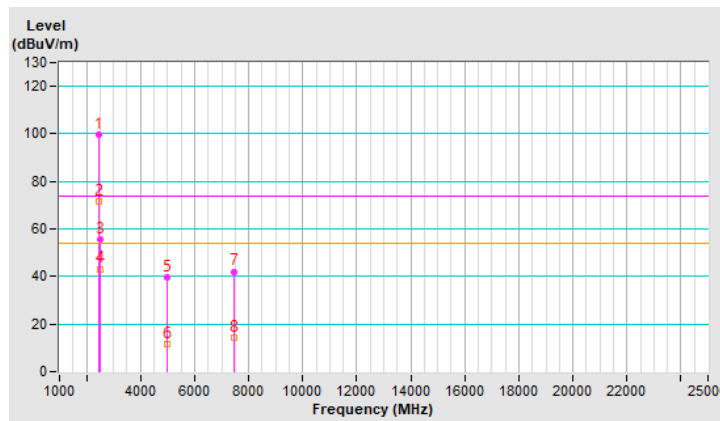



Mode C\_Plot of Band Edge

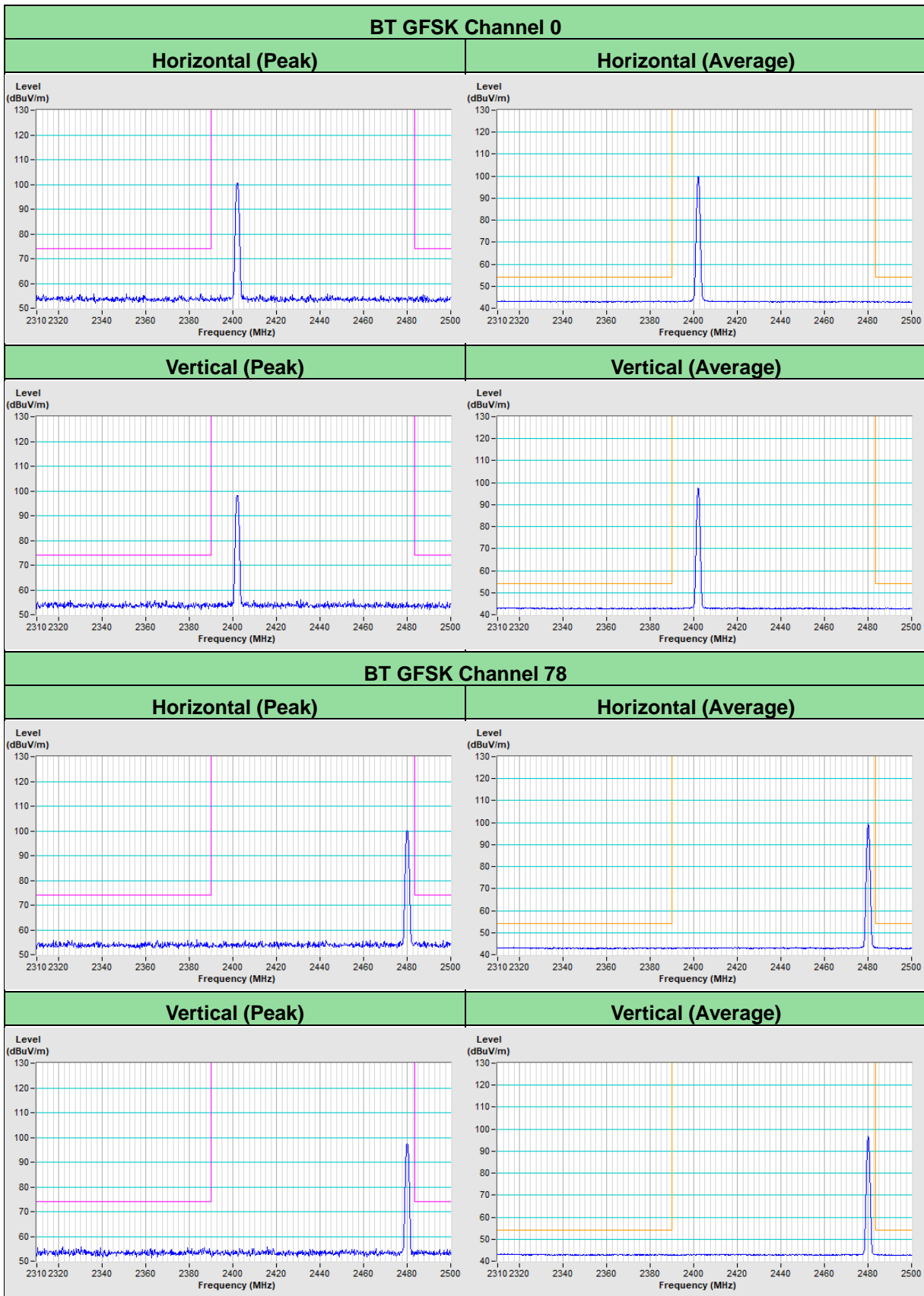

### BT 8DPSK Channel 0

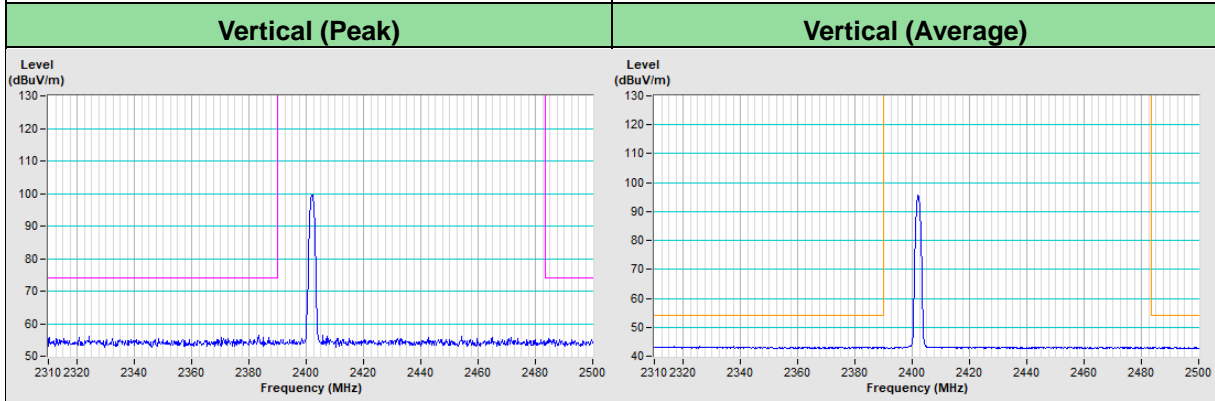
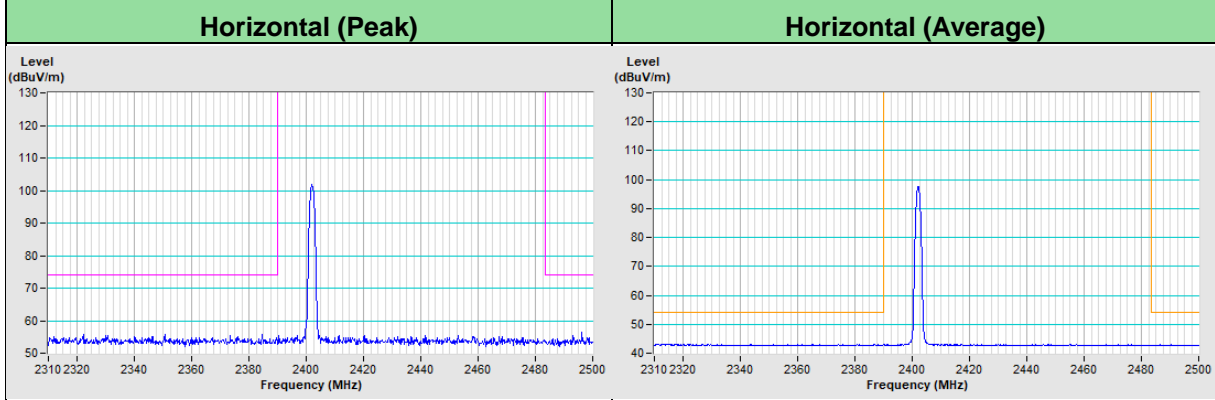

### BT 8DPSK Channel 78

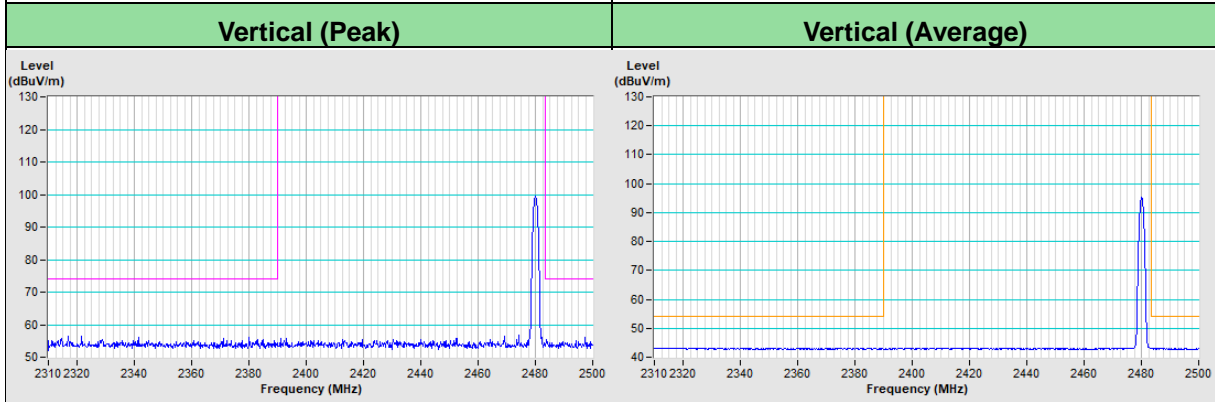
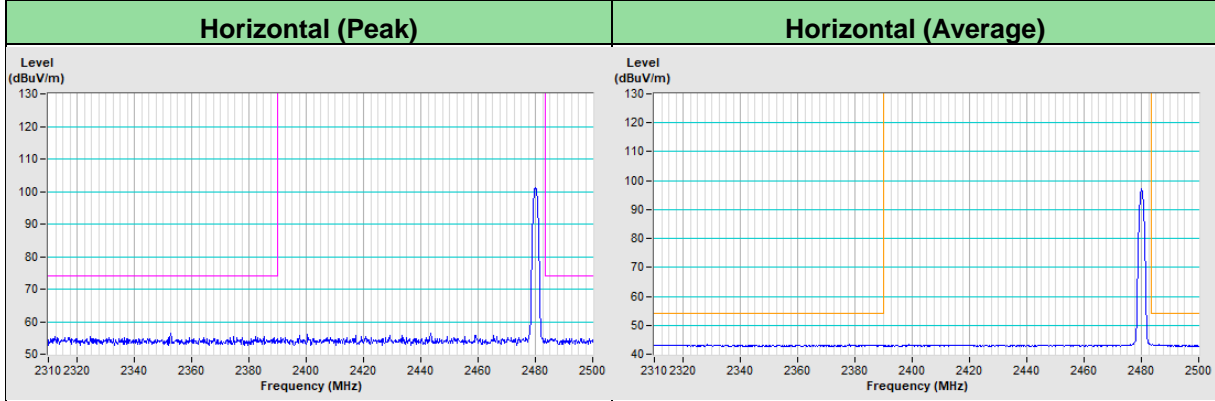

Mode D

RF Mode	TX BT GFSK	Channel	CH 0 : 2402 MHz
Frequency Range	1 GHz ~ 25 GHz	Detector Function & Bandwidth	(PK) RB = 1 MHz, VB = 3 MHz (AV) RB = 1 MHz, VB = 3 MHz
Input Power (System)	120 Vac, 60Hz	Environmental Conditions	25°C, 67% RH
Tested By	Sampson Chen		

Antenna Polarity & Test Distance : Horizontal at 3 m								
No	Frequency (MHz)	Emission Level (dBuV/m)	Limit (dBuV/m)	Margin (dB)	Antenna Height (m)	Table Angle (Degree)	Raw Value (dBuV)	Correction Factor (dB/m)
1	2382.35	55.4 PK	74.0	-18.6	1.32 H	289	58.1	-2.7
2	2382.35	43.4 AV	54.0	-10.6	1.32 H	289	46.1	-2.7
3	*2402.00	105.9 PK			1.32 H	289	108.6	-2.7
4	*2402.00	78.4 AV			1.32 H	289	81.1	-2.7
5	4804.00	40.5 PK	74.0	-33.5	1.42 H	132	39.0	1.5
6	4804.00	13.0 AV	54.0	-41.0	1.42 H	132	11.5	1.5

Remarks:

1. Emission Level(dBuV/m) = Raw Value(dBuV) + Correction Factor(dB/m)
2. Correction Factor(dB/m) = Antenna Factor(dB/m) + Cable Factor(dB) – Pre-Amplifier Factor(dB)
3. Margin value = Emission Level – Limit value
4. The other emission levels were very low against the limit.
5. " \* " : Fundamental frequency, the limit was restricted at the RF Output Power.
6. The average value of fundamental and harmonic frequency is: Average = Peak value + 20 log(Duty cycle) Where the duty cycle correction factor is calculated from following formula:  
 $20 \log(\text{Duty cycle}) = 20 \log(4.2 \text{ ms} / 100 \text{ ms}) = -27.5 \text{ dB}$

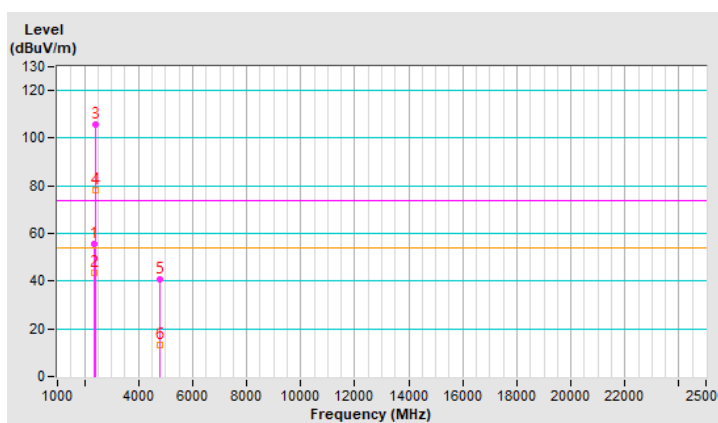

<b>RF Mode</b>	TX BT GFSK	<b>Channel</b>	CH 0 : 2402 MHz
<b>Frequency Range</b>	1 GHz ~ 25 GHz	<b>Detector Function &amp; Bandwidth</b>	(PK) RB = 1 MHz, VB = 3 MHz (AV) RB = 1 MHz, VB = 3 MHz
<b>Input Power (System)</b>	120 Vac, 60Hz	<b>Environmental Conditions</b>	25°C, 67% RH
<b>Tested By</b>	Sampson Chen		

Antenna Polarity & Test Distance : Vertical at 3 m								
No	Frequency (MHz)	Emission Level (dBuV/m)	Limit (dBuV/m)	Margin (dB)	Antenna Height (m)	Table Angle (Degree)	Raw Value (dBuV)	Correction Factor (dB/m)
1	2363.06	56.4 PK	74.0	-17.6	2.12 V	89	59.1	-2.7
2	2363.06	43.0 AV	54.0	-11.0	2.12 V	89	45.7	-2.7
3	*2402.00	104.2 PK			2.12 V	89	106.9	-2.7
4	*2402.00	76.7 AV			2.12 V	89	79.4	-2.7
5	4804.00	40.3 PK	74.0	-33.7	3.29 V	320	38.8	1.5
6	4804.00	12.8 AV	54.0	-41.2	3.29 V	320	11.3	1.5

**Remarks:**

1. Emission Level(dBuV/m) = Raw Value(dBuV) + Correction Factor(dB/m)
2. Correction Factor(dB/m) = Antenna Factor(dB/m) + Cable Factor(dB) – Pre-Amplifier Factor(dB)
3. Margin value = Emission Level – Limit value
4. The other emission levels were very low against the limit.
5. " \* " : Fundamental frequency, the limit was restricted at the RF Output Power.
6. The average value of fundamental and harmonic frequency is: Average = Peak value + 20 log(Duty cycle) Where the duty cycle correction factor is calculated from following formula:  
 $20 \log(\text{Duty cycle}) = 20 \log(4.2 \text{ ms} / 100 \text{ ms}) = -27.5 \text{ dB}$

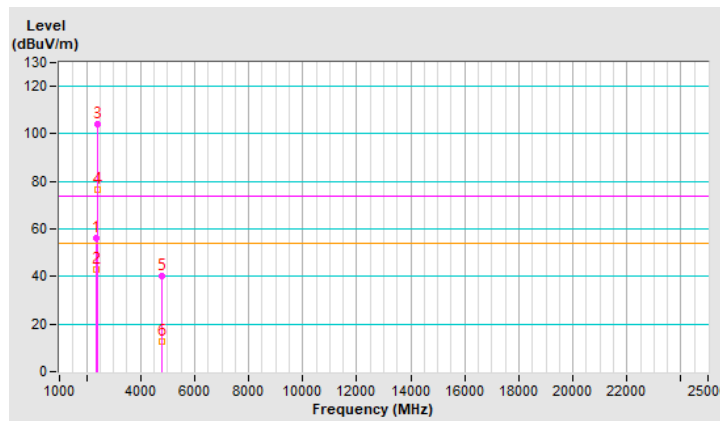

<b>RF Mode</b>	TX BT GFSK	<b>Channel</b>	CH 39 : 2441 MHz
<b>Frequency Range</b>	1 GHz ~ 25 GHz	<b>Detector Function &amp; Bandwidth</b>	(PK) RB = 1 MHz, VB = 3 MHz (AV) RB = 1 MHz, VB = 3 MHz
<b>Input Power (System)</b>	120 Vac, 60Hz	<b>Environmental Conditions</b>	25°C, 67% RH
<b>Tested By</b>	Sampson Chen		

Antenna Polarity & Test Distance : Horizontal at 3 m								
No	Frequency (MHz)	Emission Level (dBUV/m)	Limit (dBUV/m)	Margin (dB)	Antenna Height (m)	Table Angle (Degree)	Raw Value (dBUV)	Correction Factor (dB/m)
1	*2441.00	106.9 PK			1.27 H	293	109.7	-2.8
2	*2441.00	79.4 AV			1.27 H	293	82.2	-2.8
3	4882.00	40.9 PK	74.0	-33.1	1.45 H	149	39.4	1.5
4	4882.00	13.4 AV	54.0	-40.6	1.45 H	149	11.9	1.5
5	7323.00	42.7 PK	74.0	-31.3	1.63 H	118	35.5	7.2
6	7323.00	15.2 AV	54.0	-38.8	1.63 H	118	8.0	7.2

**Remarks:**

1. Emission Level(dBUV/m) = Raw Value(dBUV) + Correction Factor(dB/m)
2. Correction Factor(dB/m) = Antenna Factor(dB/m) + Cable Factor(dB) – Pre-Amplifier Factor(dB)
3. Margin value = Emission Level – Limit value
4. The other emission levels were very low against the limit.
5. " \* " : Fundamental frequency, the limit was restricted at the RF Output Power.
6. The average value of fundamental and harmonic frequency is: Average = Peak value + 20 log(Duty cycle) Where the duty cycle correction factor is calculated from following formula:  
 $20 \log(\text{Duty cycle}) = 20 \log(4.2 \text{ ms} / 100 \text{ ms}) = -27.5 \text{ dB}$

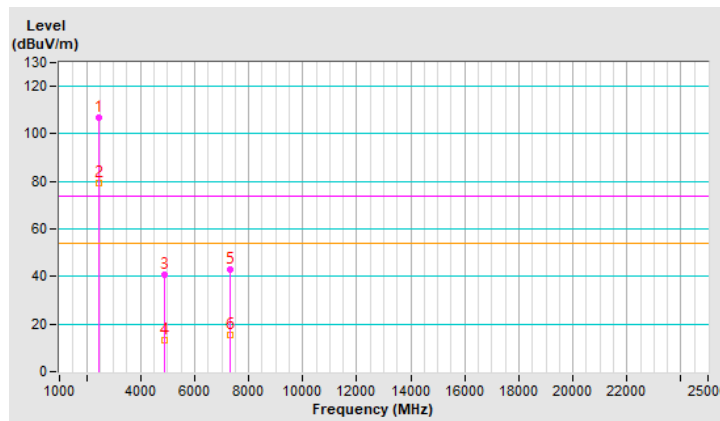

<b>RF Mode</b>	TX BT GFSK	<b>Channel</b>	CH 39 : 2441 MHz
<b>Frequency Range</b>	1 GHz ~ 25 GHz	<b>Detector Function &amp; Bandwidth</b>	(PK) RB = 1 MHz, VB = 3 MHz (AV) RB = 1 MHz, VB = 3 MHz
<b>Input Power (System)</b>	120 Vac, 60Hz	<b>Environmental Conditions</b>	25°C, 67% RH
<b>Tested By</b>	Sampson Chen		

Antenna Polarity & Test Distance : Vertical at 3 m								
No	Frequency (MHz)	Emission Level (dBuV/m)	Limit (dBuV/m)	Margin (dB)	Antenna Height (m)	Table Angle (Degree)	Raw Value (dBuV)	Correction Factor (dB/m)
1	*2441.00	105.3 PK			2.13 V	105	108.1	-2.8
2	*2441.00	77.8 AV			2.13 V	105	80.6	-2.8
3	4882.00	40.5 PK	74.0	-33.5	3.19 V	330	39.0	1.5
4	4882.00	13.0 AV	54.0	-41.0	3.19 V	330	11.5	1.5
5	7323.00	42.2 PK	74.0	-31.8	1.49 V	207	35.0	7.2
6	7323.00	14.7 AV	54.0	-39.3	1.49 V	207	7.5	7.2

**Remarks:**

1. Emission Level(dBuV/m) = Raw Value(dBuV) + Correction Factor(dB/m)
2. Correction Factor(dB/m) = Antenna Factor(dB/m) + Cable Factor(dB) – Pre-Amplifier Factor(dB)
3. Margin value = Emission Level – Limit value
4. The other emission levels were very low against the limit.
5. " \* " : Fundamental frequency, the limit was restricted at the RF Output Power.
6. The average value of fundamental and harmonic frequency is: Average = Peak value + 20 log(Duty cycle) Where the duty cycle correction factor is calculated from following formula:  
 $20 \log(\text{Duty cycle}) = 20 \log(4.2 \text{ ms} / 100 \text{ ms}) = -27.5 \text{ dB}$

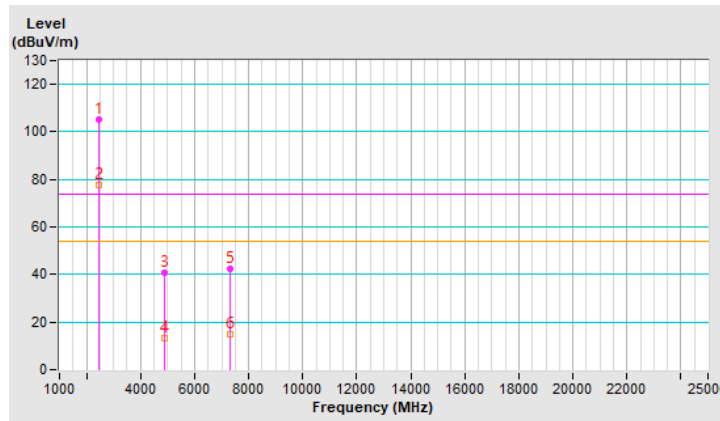

<b>RF Mode</b>	TX BT GFSK	<b>Channel</b>	CH 78 : 2480 MHz
<b>Frequency Range</b>	1 GHz ~ 25 GHz	<b>Detector Function &amp; Bandwidth</b>	(PK) RB = 1 MHz, VB = 3 MHz (AV) RB = 1 MHz, VB = 3 MHz
<b>Input Power (System)</b>	120 Vac, 60Hz	<b>Environmental Conditions</b>	25°C, 67% RH
<b>Tested By</b>	Sampson Chen		

Antenna Polarity & Test Distance : Horizontal at 3 m								
No	Frequency (MHz)	Emission Level (dBuV/m)	Limit (dBuV/m)	Margin (dB)	Antenna Height (m)	Table Angle (Degree)	Raw Value (dBuV)	Correction Factor (dB/m)
1	*2480.00	106.2 PK			1.34 H	302	109.1	-2.9
2	*2480.00	78.7 AV			1.34 H	302	81.6	-2.9
3	2488.97	55.5 PK	74.0	-18.5	1.34 H	302	58.4	-2.9
4	2488.97	43.4 AV	54.0	-10.6	1.34 H	302	46.3	-2.9
5	4960.00	41.1 PK	74.0	-32.9	1.46 H	138	39.4	1.7
6	4960.00	13.6 AV	54.0	-40.4	1.46 H	138	11.9	1.7
7	7440.00	42.5 PK	74.0	-31.5	1.60 H	132	34.9	7.6
8	7440.00	15.0 AV	54.0	-39.0	1.60 H	132	7.4	7.6

**Remarks:**

1. Emission Level(dBuV/m) = Raw Value(dBuV) + Correction Factor(dB/m)
2. Correction Factor(dB/m) = Antenna Factor(dB/m) + Cable Factor(dB) – Pre-Amplifier Factor(dB)
3. Margin value = Emission Level – Limit value
4. The other emission levels were very low against the limit.
5. " \* ": Fundamental frequency, the limit was restricted at the RF Output Power.
6. The average value of fundamental and harmonic frequency is: Average = Peak value + 20 log(Duty cycle) Where the duty cycle correction factor is calculated from following formula:  
 $20 \log(\text{Duty cycle}) = 20 \log(4.2 \text{ ms} / 100 \text{ ms}) = -27.5 \text{ dB}$

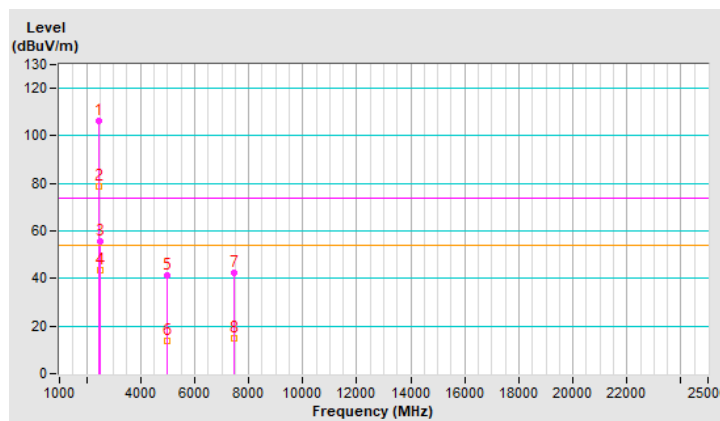

<b>RF Mode</b>	TX BT GFSK	<b>Channel</b>	CH 78 : 2480 MHz
<b>Frequency Range</b>	1 GHz ~ 25 GHz	<b>Detector Function &amp; Bandwidth</b>	(PK) RB = 1 MHz, VB = 3 MHz (AV) RB = 1 MHz, VB = 3 MHz
<b>Input Power (System)</b>	120 Vac, 60Hz	<b>Environmental Conditions</b>	25°C, 67% RH
<b>Tested By</b>	Sampson Chen		

Antenna Polarity & Test Distance : Vertical at 3 m								
No	Frequency (MHz)	Emission Level (dBuV/m)	Limit (dBuV/m)	Margin (dB)	Antenna Height (m)	Table Angle (Degree)	Raw Value (dBuV)	Correction Factor (dB/m)
1	*2480.00	104.0 PK			2.10 V	103	106.9	-2.9
2	*2480.00	76.5 AV			2.10 V	103	79.4	-2.9
3	2483.50	54.6 PK	74.0	-19.4	2.10 V	103	57.5	-2.9
4	2483.50	43.4 AV	54.0	-10.6	2.10 V	103	46.3	-2.9
5	4960.00	40.1 PK	74.0	-33.9	3.24 V	330	38.4	1.7
6	4960.00	12.6 AV	54.0	-41.4	3.24 V	330	10.9	1.7
7	7440.00	41.8 PK	74.0	-32.2	1.54 V	200	34.2	7.6
8	7440.00	14.3 AV	54.0	-39.7	1.54 V	200	6.7	7.6

**Remarks:**

1. Emission Level(dBuV/m) = Raw Value(dBuV) + Correction Factor(dB/m)
2. Correction Factor(dB/m) = Antenna Factor(dB/m) + Cable Factor(dB) – Pre-Amplifier Factor(dB)
3. Margin value = Emission Level – Limit value
4. The other emission levels were very low against the limit.
5. " \* ": Fundamental frequency, the limit was restricted at the RF Output Power.
6. The average value of fundamental and harmonic frequency is: Average = Peak value + 20 log(Duty cycle) Where the duty cycle correction factor is calculated from following formula:  
 $20 \log(\text{Duty cycle}) = 20 \log(4.2 \text{ ms} / 100 \text{ ms}) = -27.5 \text{ dB}$

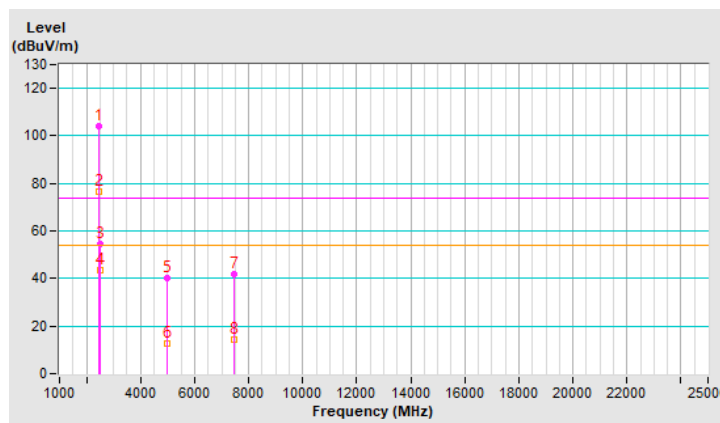



<b>RF Mode</b>	TX BT 8DPSK	<b>Channel</b>	CH 0 : 2402 MHz
<b>Frequency Range</b>	1 GHz ~ 25 GHz	<b>Detector Function &amp; Bandwidth</b>	(PK) RB = 1 MHz, VB = 3 MHz (AV) RB = 1 MHz, VB = 3 MHz
<b>Input Power (System)</b>	120 Vac, 60Hz	<b>Environmental Conditions</b>	25°C, 67% RH
<b>Tested By</b>	Sampson Chen		

Antenna Polarity & Test Distance : Horizontal at 3 m								
No	Frequency (MHz)	Emission Level (dBuV/m)	Limit (dBuV/m)	Margin (dB)	Antenna Height (m)	Table Angle (Degree)	Raw Value (dBuV)	Correction Factor (dB/m)
1	2340.76	55.7 PK	74.0	-18.3	1.38 H	295	58.4	-2.7
2	2340.76	43.2 AV	54.0	-10.8	1.38 H	295	45.9	-2.7
3	*2402.00	106.6 PK			1.38 H	295	109.3	-2.7
4	*2402.00	78.6 AV			1.38 H	295	81.3	-2.7
5	4804.00	42.4 PK	74.0	-31.6	1.27 H	157	40.9	1.5
6	4804.00	14.4 AV	54.0	-39.6	1.27 H	157	12.9	1.5

**Remarks:**

1. Emission Level(dBuV/m) = Raw Value(dBuV) + Correction Factor(dB/m)
2. Correction Factor(dB/m) = Antenna Factor(dB/m) + Cable Factor(dB) – Pre-Amplifier Factor(dB)
3. Margin value = Emission Level – Limit value
4. The other emission levels were very low against the limit.
5. " \* " : Fundamental frequency, the limit was restricted at the RF Output Power.
6. The average value of fundamental and harmonic frequency is: Average = Peak value + 20 log(Duty cycle) Where the duty cycle correction factor is calculated from following formula:  
 $20 \log(\text{Duty cycle}) = 20 \log(4 \text{ ms} / 100 \text{ ms}) = -28.0 \text{ dB}$

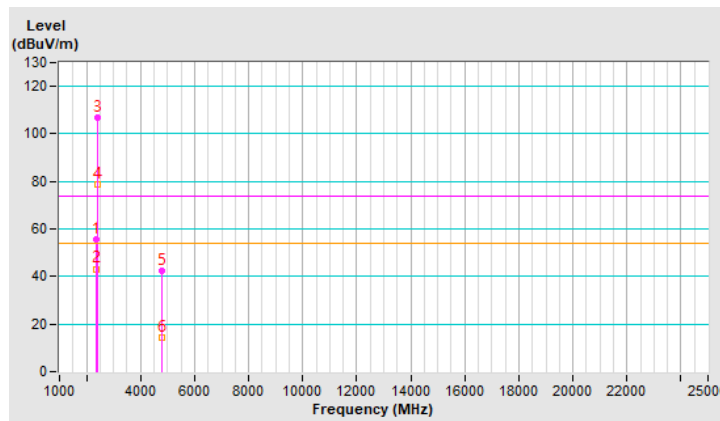

<b>RF Mode</b>	TX BT 8DPSK	<b>Channel</b>	CH 0 : 2402 MHz
<b>Frequency Range</b>	1 GHz ~ 25 GHz	<b>Detector Function &amp; Bandwidth</b>	(PK) RB = 1 MHz, VB = 3 MHz (AV) RB = 1 MHz, VB = 3 MHz
<b>Input Power (System)</b>	120 Vac, 60Hz	<b>Environmental Conditions</b>	25°C, 67% RH
<b>Tested By</b>	Sampson Chen		

Antenna Polarity & Test Distance : Vertical at 3 m								
No	Frequency (MHz)	Emission Level (dBuV/m)	Limit (dBuV/m)	Margin (dB)	Antenna Height (m)	Table Angle (Degree)	Raw Value (dBuV)	Correction Factor (dB/m)
1	2380.38	55.6 PK	74.0	-18.4	2.09 V	110	58.3	-2.7
2	2380.38	43.2 AV	54.0	-10.8	2.09 V	110	45.9	-2.7
3	*2402.00	104.9 PK			2.09 V	110	107.6	-2.7
4	*2402.00	76.9 AV			2.09 V	110	79.6	-2.7
5	4804.00	38.9 PK	74.0	-35.1	3.20 V	340	37.4	1.5
6	4804.00	10.9 AV	54.0	-43.1	3.20 V	340	9.4	1.5

**Remarks:**

1. Emission Level(dBuV/m) = Raw Value(dBuV) + Correction Factor(dB/m)
2. Correction Factor(dB/m) = Antenna Factor(dB/m) + Cable Factor(dB) – Pre-Amplifier Factor(dB)
3. Margin value = Emission Level – Limit value
4. The other emission levels were very low against the limit.
5. " \* " : Fundamental frequency, the limit was restricted at the RF Output Power.
6. The average value of fundamental and harmonic frequency is: Average = Peak value + 20 log(Duty cycle) Where the duty cycle correction factor is calculated from following formula:  
 $20 \log(\text{Duty cycle}) = 20 \log(4 \text{ ms} / 100 \text{ ms}) = -28.0 \text{ dB}$

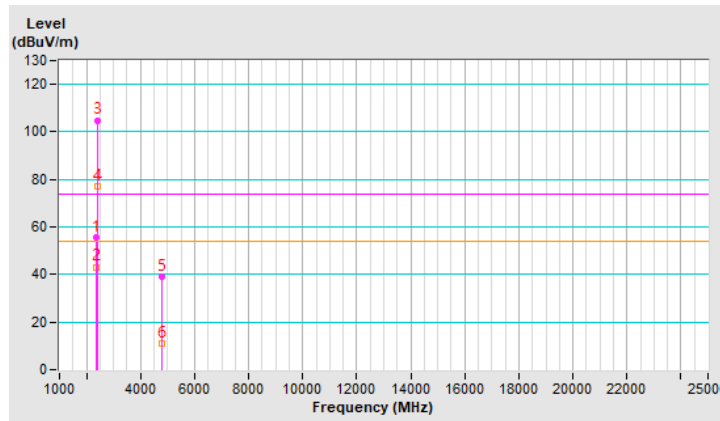

<b>RF Mode</b>	TX BT 8DPSK	<b>Channel</b>	CH 39 : 2441 MHz
<b>Frequency Range</b>	1 GHz ~ 25 GHz	<b>Detector Function &amp; Bandwidth</b>	(PK) RB = 1 MHz, VB = 3 MHz (AV) RB = 1 MHz, VB = 3 MHz
<b>Input Power (System)</b>	120 Vac, 60Hz	<b>Environmental Conditions</b>	25°C, 67% RH
<b>Tested By</b>	Sampson Chen		

Antenna Polarity & Test Distance : Horizontal at 3 m								
No	Frequency (MHz)	Emission Level (dBuV/m)	Limit (dBuV/m)	Margin (dB)	Antenna Height (m)	Table Angle (Degree)	Raw Value (dBuV)	Correction Factor (dB/m)
1	*2441.00	106.5 PK			1.34 H	312	109.3	-2.8
2	*2441.00	78.5 AV			1.34 H	312	81.3	-2.8
3	4882.00	42.3 PK	74.0	-31.7	1.34 H	163	40.8	1.5
4	4882.00	14.3 AV	54.0	-39.7	1.34 H	163	12.8	1.5
5	7323.00	41.4 PK	74.0	-32.6	1.43 H	19	34.2	7.2
6	7323.00	13.4 AV	54.0	-40.6	1.43 H	19	6.2	7.2

**Remarks:**

1. Emission Level(dBuV/m) = Raw Value(dBuV) + Correction Factor(dB/m)
2. Correction Factor(dB/m) = Antenna Factor(dB/m) + Cable Factor(dB) – Pre-Amplifier Factor(dB)
3. Margin value = Emission Level – Limit value
4. The other emission levels were very low against the limit.
5. " \* " : Fundamental frequency, the limit was restricted at the RF Output Power.
6. The average value of fundamental and harmonic frequency is: Average = Peak value + 20 log(Duty cycle) Where the duty cycle correction factor is calculated from following formula:  
 $20 \log(\text{Duty cycle}) = 20 \log(4 \text{ ms} / 100 \text{ ms}) = -28.0 \text{ dB}$

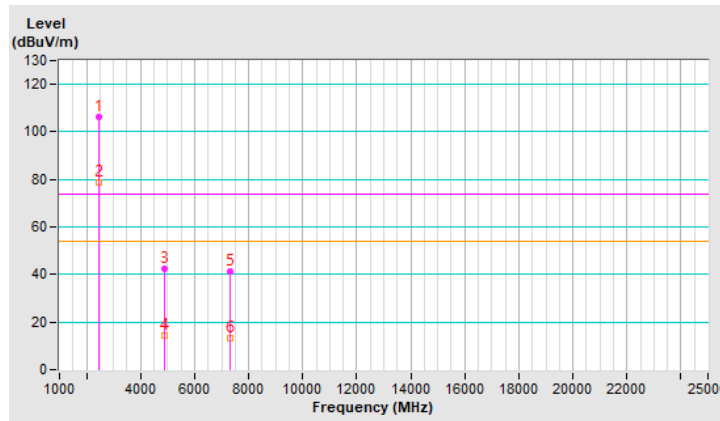

<b>RF Mode</b>	TX BT 8DPSK	<b>Channel</b>	CH 39 : 2441 MHz
<b>Frequency Range</b>	1 GHz ~ 25 GHz	<b>Detector Function &amp; Bandwidth</b>	(PK) RB = 1 MHz, VB = 3 MHz (AV) RB = 1 MHz, VB = 3 MHz
<b>Input Power (System)</b>	120 Vac, 60Hz	<b>Environmental Conditions</b>	25°C, 67% RH
<b>Tested By</b>	Sampson Chen		

Antenna Polarity & Test Distance : Vertical at 3 m								
No	Frequency (MHz)	Emission Level (dBuV/m)	Limit (dBuV/m)	Margin (dB)	Antenna Height (m)	Table Angle (Degree)	Raw Value (dBuV)	Correction Factor (dB/m)
1	*2441.00	105.3 PK			2.12 V	119	108.1	-2.8
2	*2441.00	77.3 AV			2.12 V	119	80.1	-2.8
3	4882.00	39.3 PK	74.0	-34.7	3.27 V	323	37.8	1.5
4	4882.00	11.3 AV	54.0	-42.7	3.27 V	323	9.8	1.5
5	7323.00	42.8 PK	74.0	-31.2	1.60 V	191	35.6	7.2
6	7323.00	14.8 AV	54.0	-39.2	1.60 V	191	7.6	7.2

**Remarks:**

1. Emission Level(dBuV/m) = Raw Value(dBuV) + Correction Factor(dB/m)
2. Correction Factor(dB/m) = Antenna Factor(dB/m) + Cable Factor(dB) – Pre-Amplifier Factor(dB)
3. Margin value = Emission Level – Limit value
4. The other emission levels were very low against the limit.
5. " \* " : Fundamental frequency, the limit was restricted at the RF Output Power.
6. The average value of fundamental and harmonic frequency is: Average = Peak value + 20 log(Duty cycle) Where the duty cycle correction factor is calculated from following formula:  
 $20 \log(\text{Duty cycle}) = 20 \log(4 \text{ ms} / 100 \text{ ms}) = -28.0 \text{ dB}$

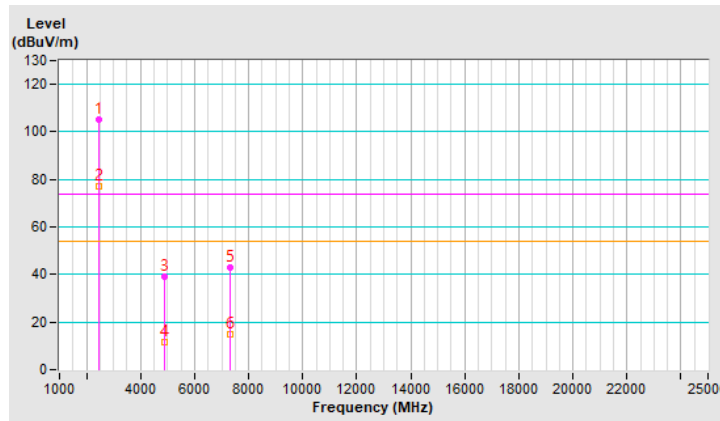

<b>RF Mode</b>	TX BT 8DPSK	<b>Channel</b>	CH 78 : 2480 MHz
<b>Frequency Range</b>	1 GHz ~ 25 GHz	<b>Detector Function &amp; Bandwidth</b>	(PK) RB = 1 MHz, VB = 3 MHz (AV) RB = 1 MHz, VB = 3 MHz
<b>Input Power (System)</b>	120 Vac, 60Hz	<b>Environmental Conditions</b>	25°C, 67% RH
<b>Tested By</b>	Sampson Chen		

Antenna Polarity & Test Distance : Horizontal at 3 m								
No	Frequency (MHz)	Emission Level (dBuV/m)	Limit (dBuV/m)	Margin (dB)	Antenna Height (m)	Table Angle (Degree)	Raw Value (dBuV)	Correction Factor (dB/m)
1	*2480.00	106.8 PK			1.40 H	308	109.7	-2.9
2	*2480.00	78.8 AV			1.40 H	308	81.7	-2.9
3	2485.73	55.7 PK	74.0	-18.3	1.40 H	308	58.6	-2.9
4	2485.73	43.5 AV	54.0	-10.5	1.40 H	308	46.4	-2.9
5	4960.00	42.6 PK	74.0	-31.4	1.26 H	140	40.9	1.7
6	4960.00	14.6 AV	54.0	-39.4	1.26 H	140	12.9	1.7
7	7440.00	41.5 PK	74.0	-32.5	1.42 H	7	33.9	7.6
8	7440.00	13.5 AV	54.0	-40.5	1.42 H	7	5.9	7.6

**Remarks:**

1. Emission Level(dBuV/m) = Raw Value(dBuV) + Correction Factor(dB/m)
2. Correction Factor(dB/m) = Antenna Factor(dB/m) + Cable Factor(dB) – Pre-Amplifier Factor(dB)
3. Margin value = Emission Level – Limit value
4. The other emission levels were very low against the limit.
5. " \* ": Fundamental frequency, the limit was restricted at the RF Output Power.
6. The average value of fundamental and harmonic frequency is: Average = Peak value + 20 log(Duty cycle) Where the duty cycle correction factor is calculated from following formula:  
 $20 \log(\text{Duty cycle}) = 20 \log(4 \text{ ms} / 100 \text{ ms}) = -28.0 \text{ dB}$

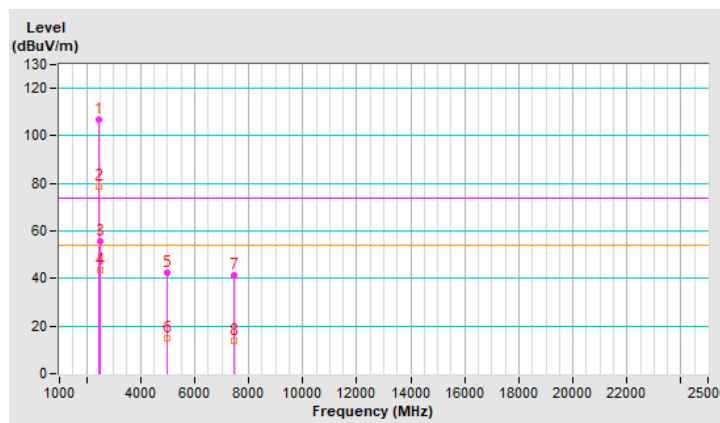

<b>RF Mode</b>	TX BT 8DPSK	<b>Channel</b>	CH 78 : 2480 MHz
<b>Frequency Range</b>	1 GHz ~ 25 GHz	<b>Detector Function &amp; Bandwidth</b>	(PK) RB = 1 MHz, VB = 3 MHz (AV) RB = 1 MHz, VB = 3 MHz
<b>Input Power (System)</b>	120 Vac, 60Hz	<b>Environmental Conditions</b>	25°C, 67% RH
<b>Tested By</b>	Sampson Chen		

Antenna Polarity & Test Distance : Vertical at 3 m								
No	Frequency (MHz)	Emission Level (dBuV/m)	Limit (dBuV/m)	Margin (dB)	Antenna Height (m)	Table Angle (Degree)	Raw Value (dBuV)	Correction Factor (dB/m)
1	*2480.00	104.8 PK			2.10 V	110	107.7	-2.9
2	*2480.00	76.8 AV			2.10 V	110	79.7	-2.9
3	2483.50	55.3 PK	74.0	-18.7	2.10 V	110	58.2	-2.9
4	2483.50	43.7 AV	54.0	-10.3	2.10 V	110	46.6	-2.9
5	4960.00	38.7 PK	74.0	-35.3	3.21 V	344	37.0	1.7
6	4960.00	10.7 AV	54.0	-43.3	3.21 V	344	9.0	1.7
7	7440.00	42.2 PK	74.0	-31.8	1.55 V	186	34.6	7.6
8	7440.00	14.2 AV	54.0	-39.8	1.55 V	186	6.6	7.6

**Remarks:**

1. Emission Level(dBuV/m) = Raw Value(dBuV) + Correction Factor(dB/m)
2. Correction Factor(dB/m) = Antenna Factor(dB/m) + Cable Factor(dB) – Pre-Amplifier Factor(dB)
3. Margin value = Emission Level – Limit value
4. The other emission levels were very low against the limit.
5. " \* ": Fundamental frequency, the limit was restricted at the RF Output Power.
6. The average value of fundamental and harmonic frequency is: Average = Peak value + 20 log(Duty cycle) Where the duty cycle correction factor is calculated from following formula:  
 $20 \log(\text{Duty cycle}) = 20 \log(4 \text{ ms} / 100 \text{ ms}) = -28.0 \text{ dB}$

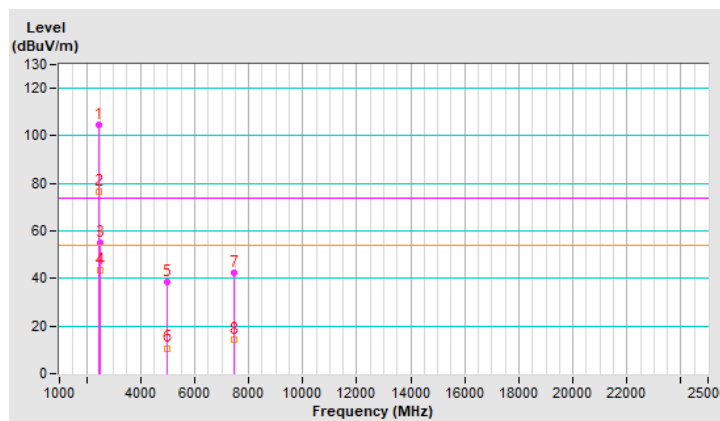

### Mode D\_Plot of Band Edge

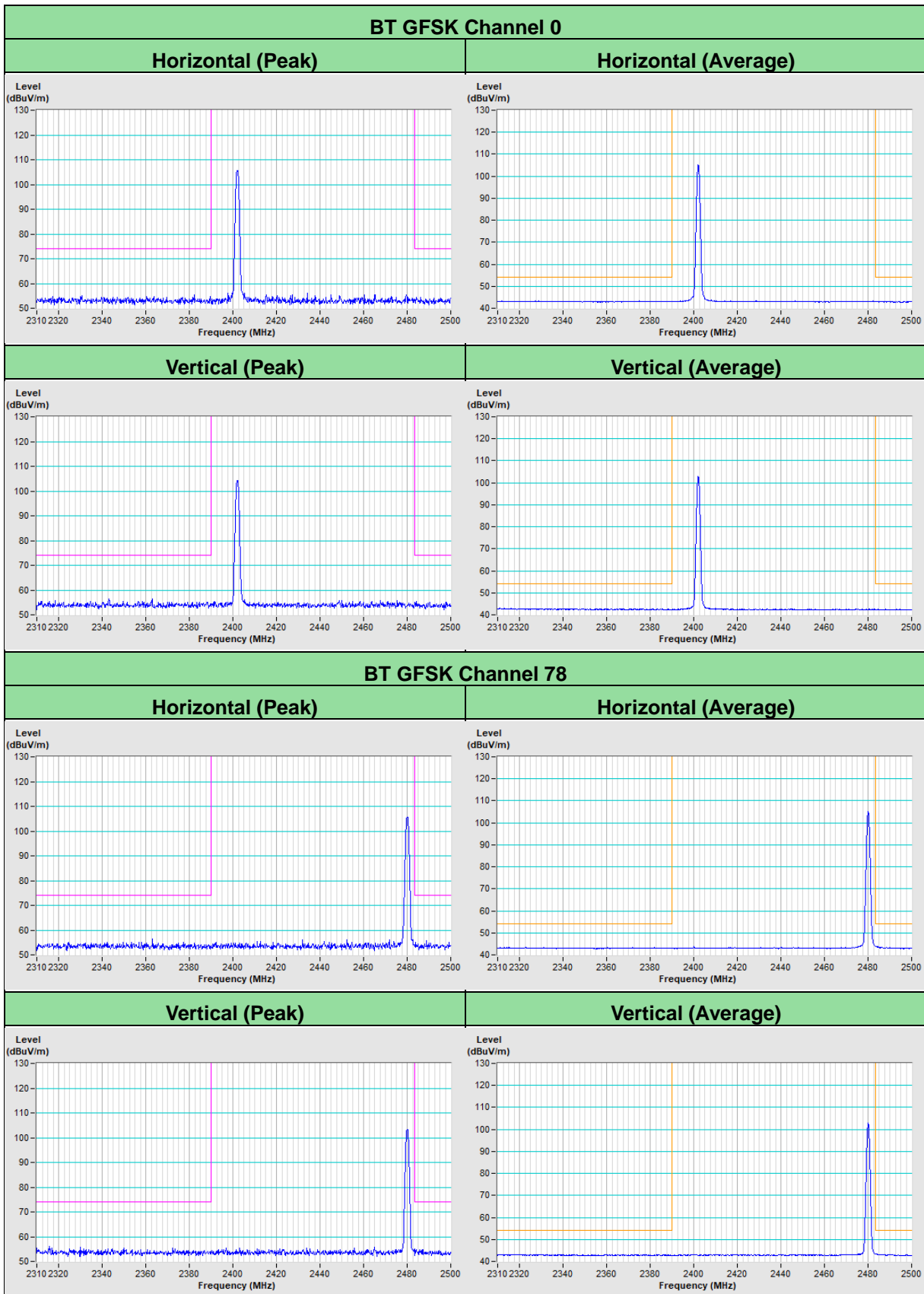

### BT 8DPSK Channel 0

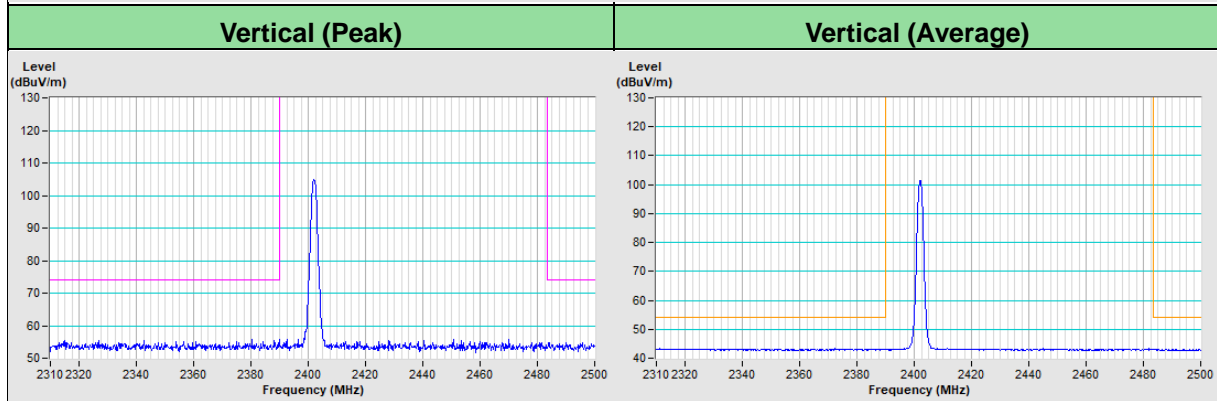
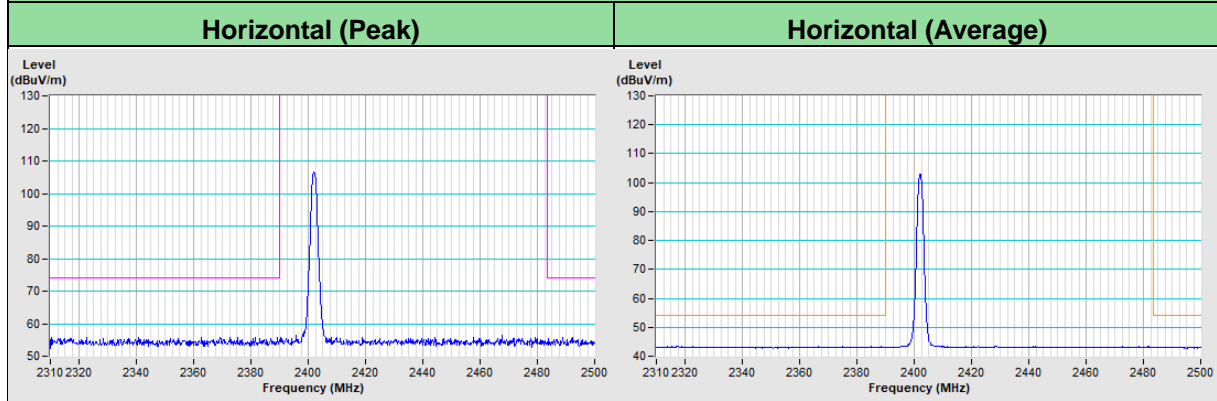

### BT 8DPSK Channel 78

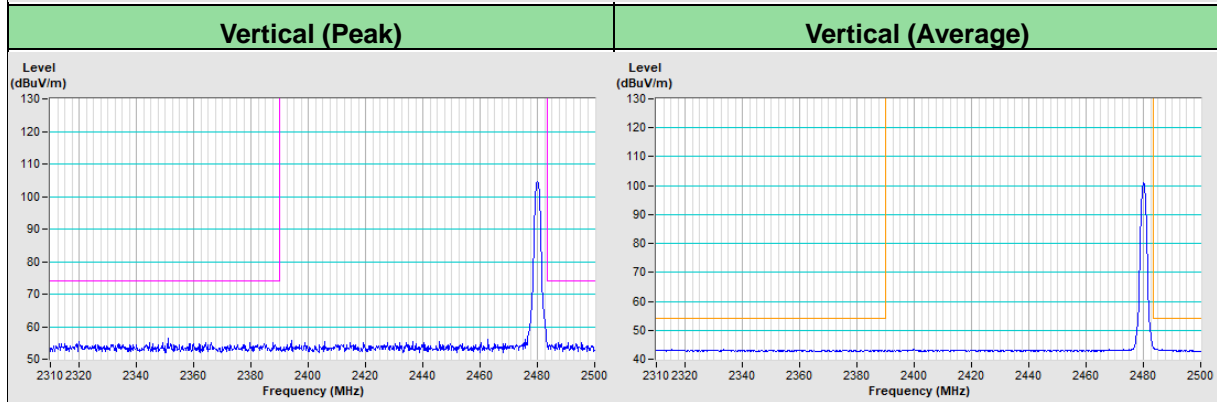
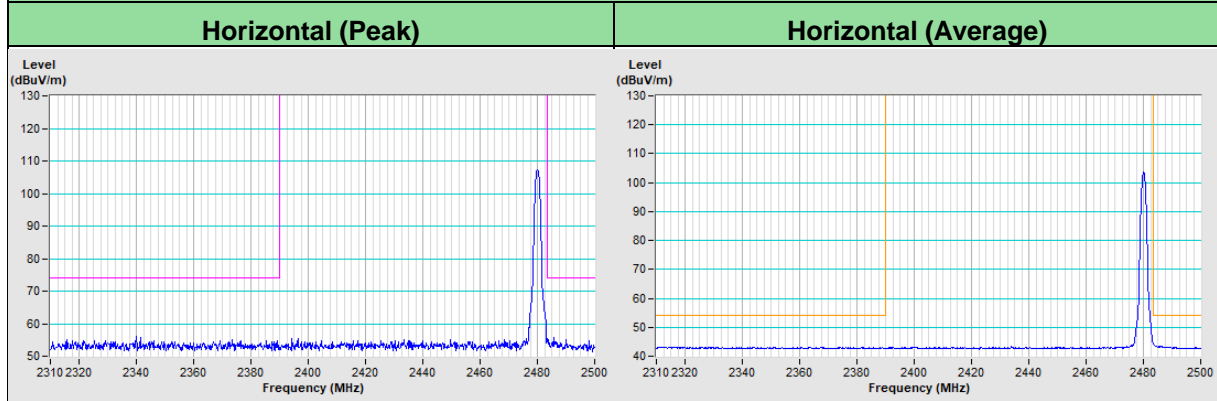



## 8 Pictures of Test Arrangements

Please refer to the attached file (Test Setup Photo)

## 9 Information of the Testing Laboratories

We, Bureau Veritas Consumer Products Services (H.K.) Ltd., Taoyuan Branch, were founded in 1988 to provide our best service in EMC, Radio, Telecom and Safety consultation. Our laboratories are FCC recognized accredited test firms and accredited according to ISO/IEC 17025.

If you have any comments, please feel free to contact us at the following:

**Lin Kou EMC/RF Lab**

Tel: 886-2-26052180

Fax: 886-2-26051924

**Hsin Chu EMC/RF/Telecom Lab**

Tel: 886-3-6668565

Fax: 886-3-6668323

**Hwa Ya EMC/RF/Safety Lab**

Tel: 886-3-3183232

Fax: 886-3-3270892

**Email:** [service.adt@bureauveritas.com](mailto:service.adt@bureauveritas.com)

**Web Site:** <http://ee.bureauveritas.com.tw>

The address and road map of all our labs can be found in our web site also.

--- END ---