

NOTE:

- 1.No sharp edges/ chips,no sink mark, injection mark, flow line,flash and welding line should be visible on appearance surface.
- 2.Warping should be 0.3mm per 100mm ; part max 0.5mm.
- 3.The geometry dimensions of enclosure is based on 3d model
- 4.Surface finish:Don't have shrink marks and scratches
- 5.This drawing contains critical to function dimension only, refer to the 3d-cad file for complete part information.
- 6.Parts should meet RoHS.
- 7.The interior of the material should be added to the date code and the recycling symbol.

- 1 孔徑由2.2-->3.0mm(2017/07/06)
- 2 增加尺寸7.47+0.0/-0.3mm(2018/09/21)
- 3 孔徑增加公差由2.8-->2.8+0.2/-0.1mm(2019/07/06)
- 4 去除皮膜(2022/06/16)

ITEM	DATE	REMARK	DESIGNED	APPROVED
1				
2				
3				

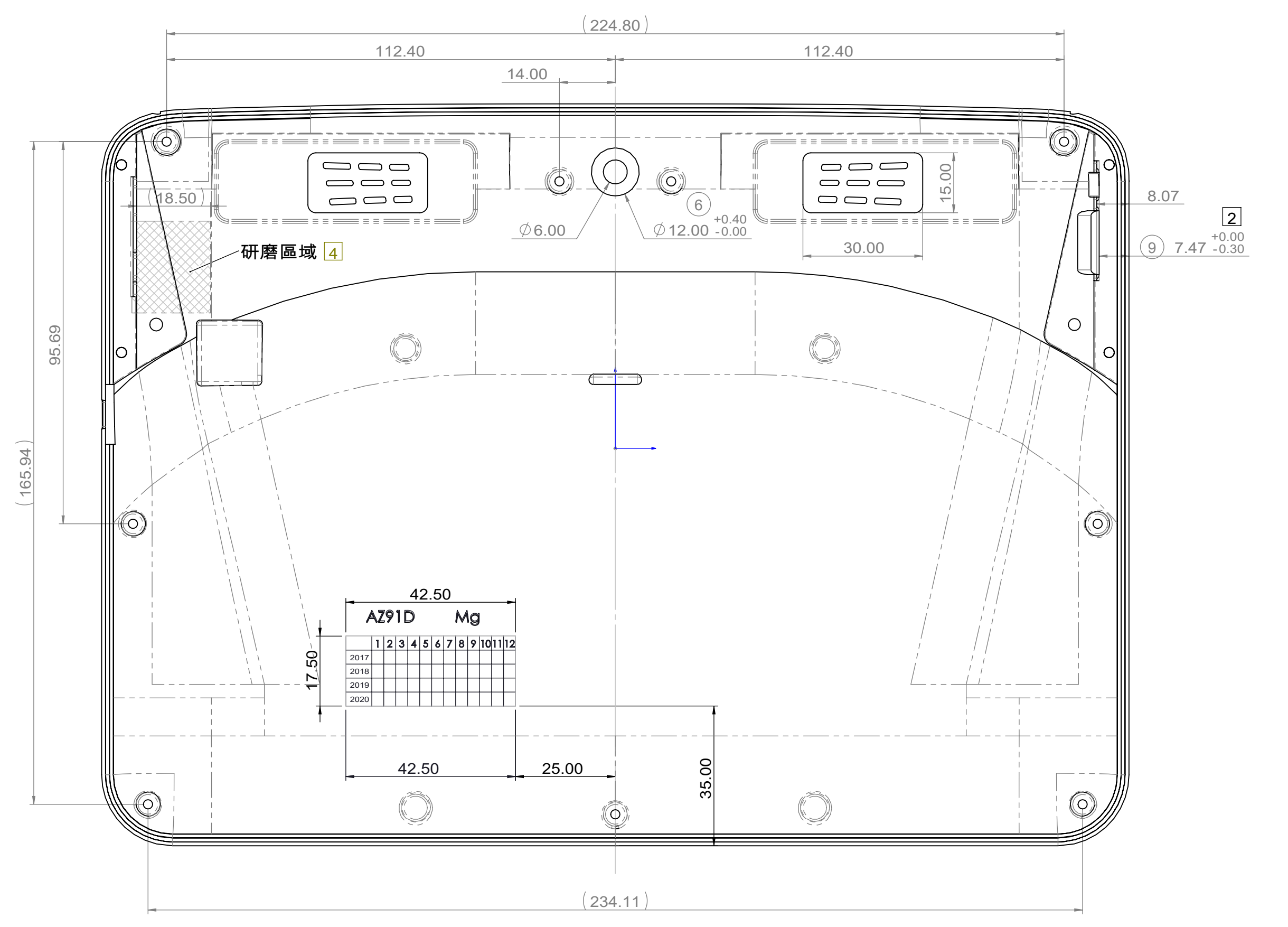
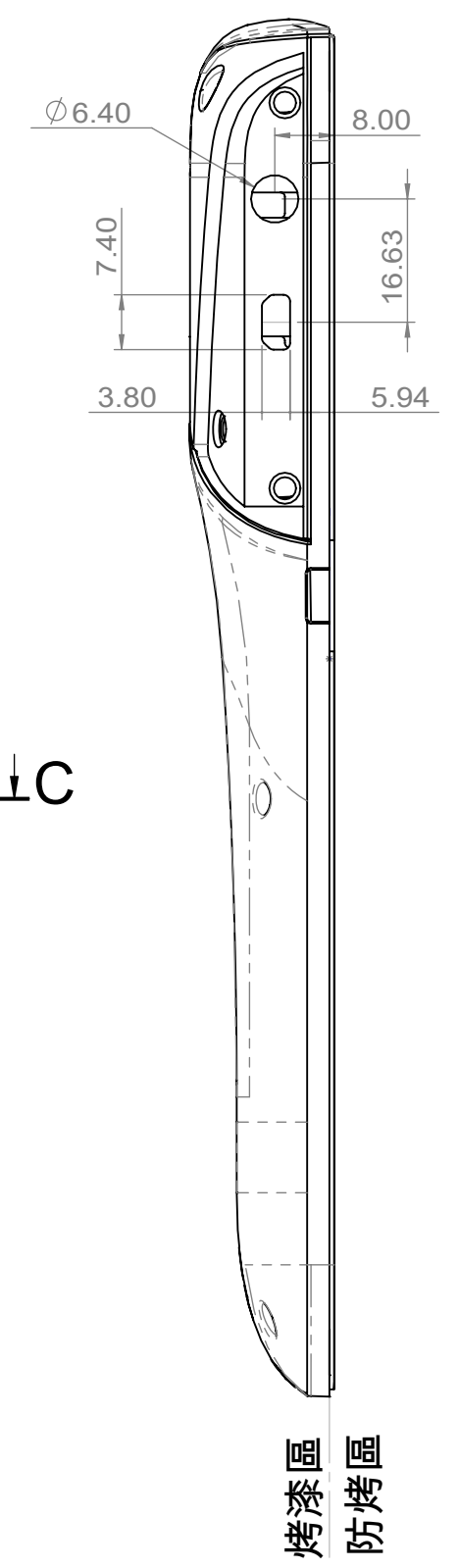
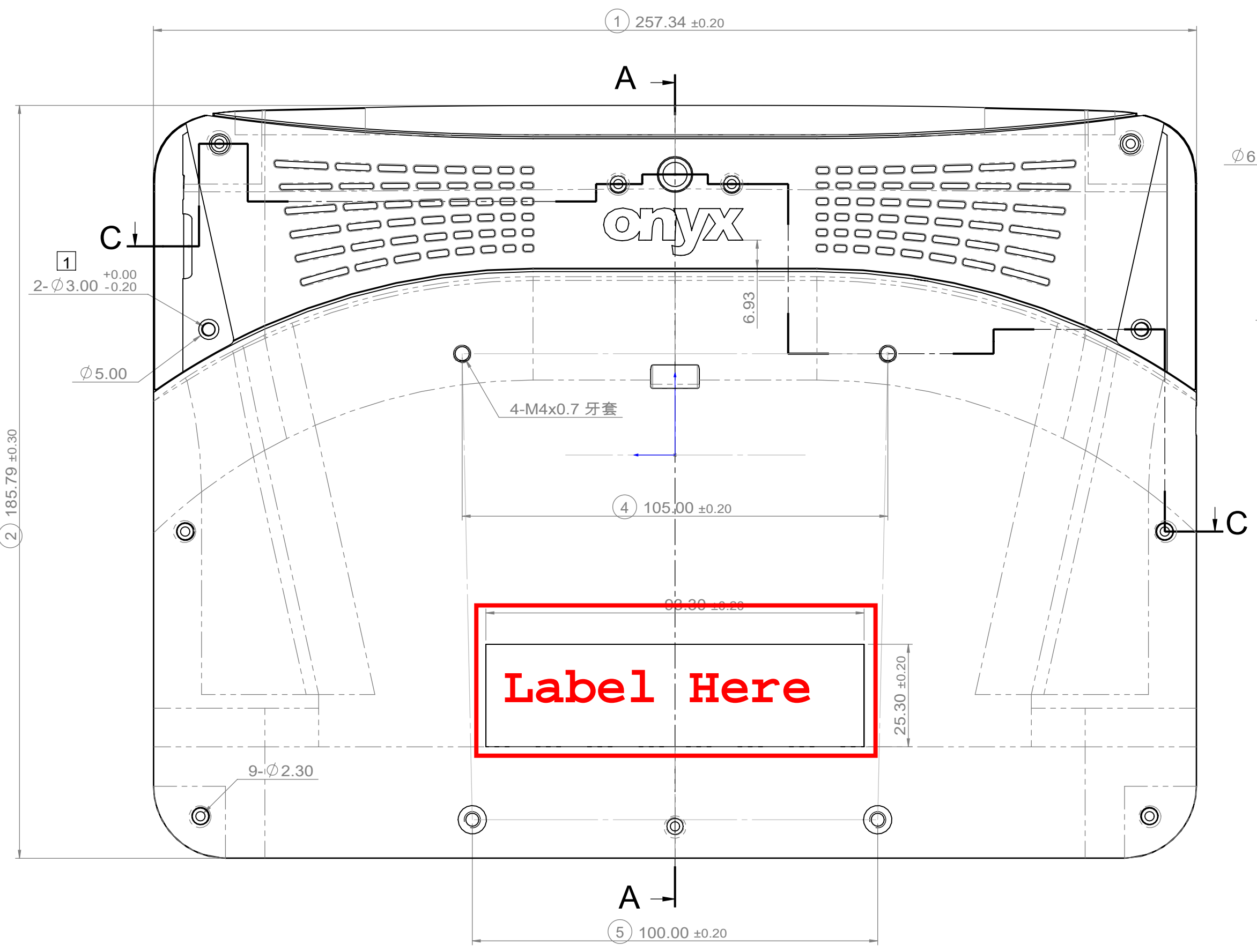
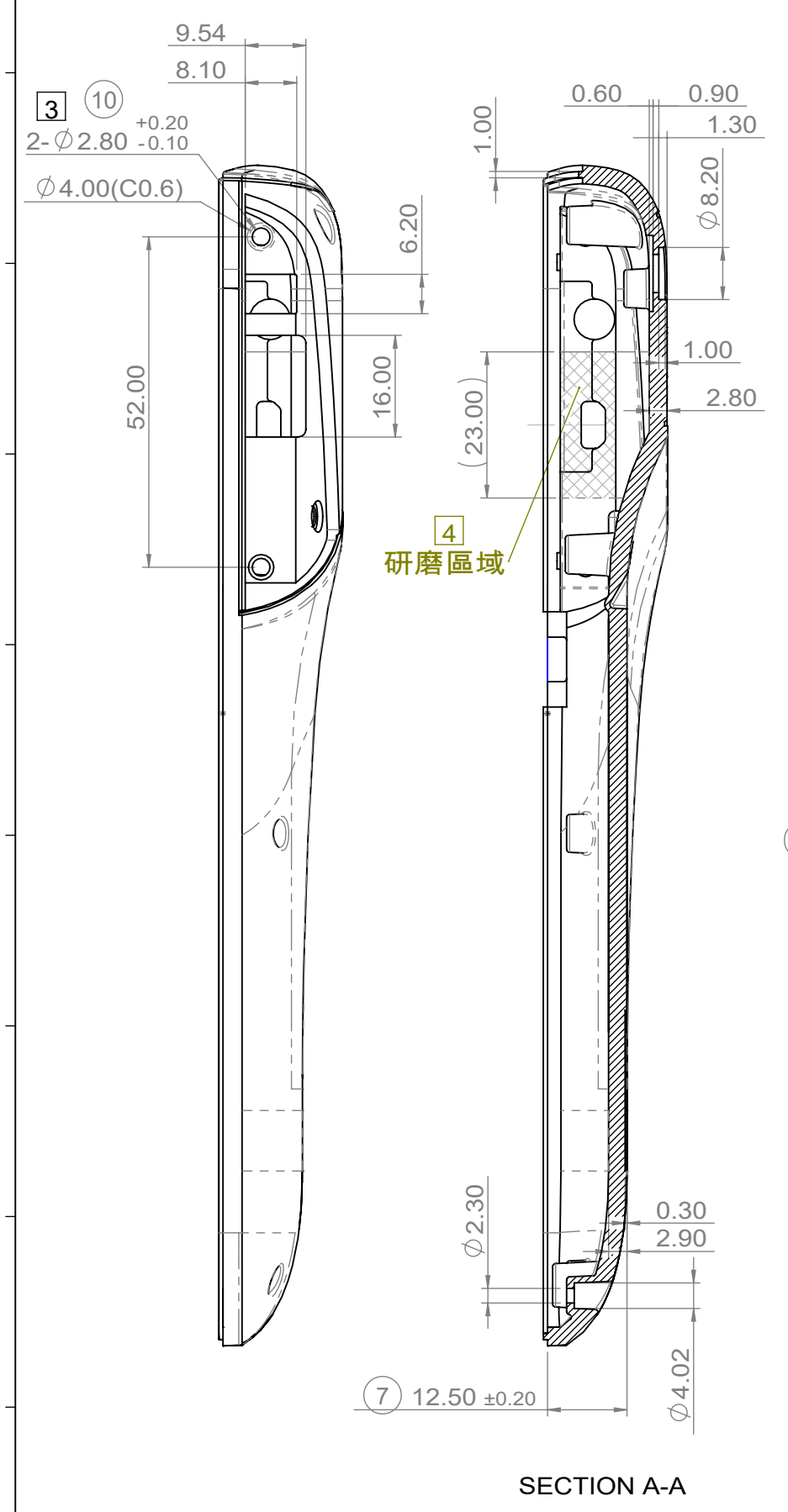
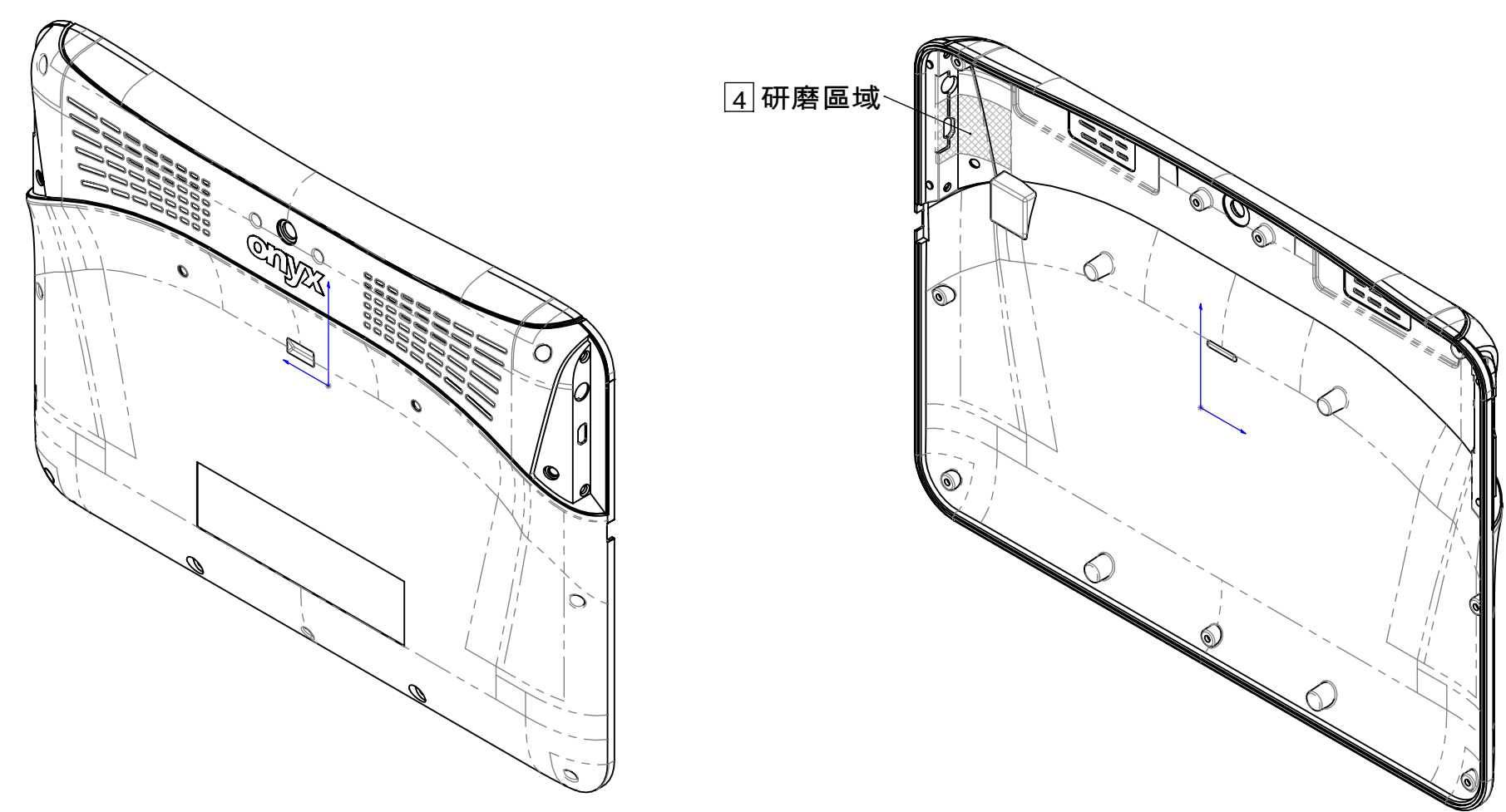
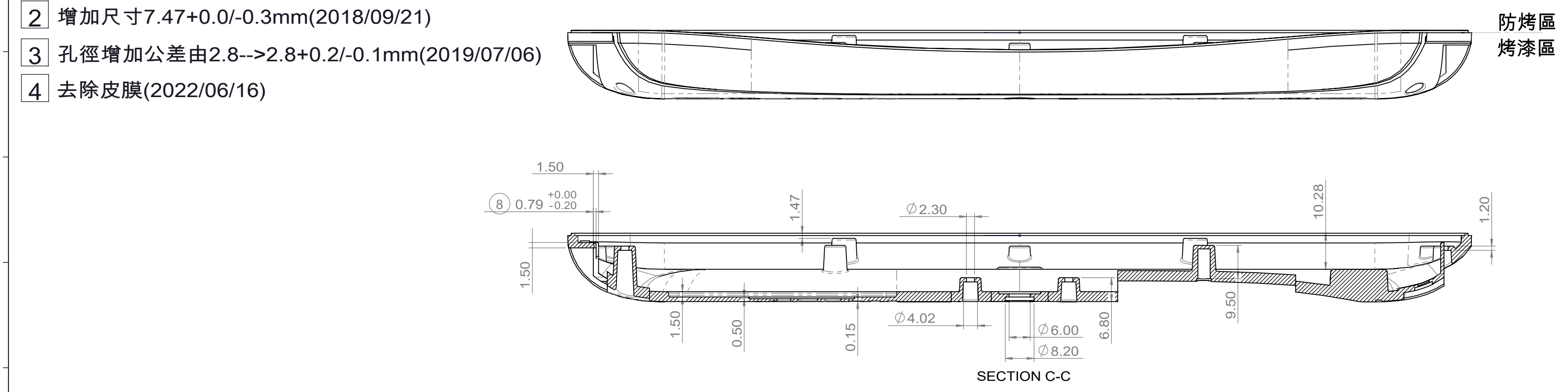

Paint color : PMS Cool Gray 10C H00
Print color : PMS# 7468C

GENERAL TOL	MATERIAL: Mg-Al	PART No. M94M101030	onyx Healthcare Inc.	
>0 ±0.1	SPEC.: AZ91D	DWG No. M94M101030	醫揚科技股份有限公司	
>10 ±0.2	FINISH: PMS Cool Gray 10C H00	APPROVED	CHECKED	DESIGNED
>50 ±0.3	UNIT: MM	Ernest	Johnny	MODEL No. MD101
>200 ±0.5	ANGLE TOL: ±0.5°	2017/04/18	2017/04/18	REV. 0.4
>500 ±0.8	SCALE: 1/1			SHEET: 1 / 1