

## Appendix A. SAR Plots of System Verification

The plots for system verification with largest deviation for each SAR system combination are shown as follows.

## System Check\_H2450\_200307

**DUT: Dipole 2450 MHz; Type: D2450V2; SN: 737**

Communication System: CW; Frequency: 2450 MHz; Duty Cycle: 1:1

Medium: H19T27N1\_0307 Medium parameters used:  $f = 2450$  MHz;  $\sigma = 1.864$  S/m;  $\epsilon_r = 38.922$ ;  $\rho = 1000$  kg/m<sup>3</sup>

Ambient Temperature : 23.6 °C ; Liquid Temperature : 23.3 °C

DASY5 Configuration:

- Probe: EX3DV4 - SN3820; ConvF(6.95, 6.95, 6.95); Calibrated: 2019/06/25
- Sensor-Surface: 1.4mm (Mechanical Surface Detection)
- Electronics: DAE4 Sn916; Calibrated: 2019/12/17
- Phantom: SAM Phantom\_1982; Type: QD 000 P41 Ax; Serial: 1982
- Measurement SW: DASY52, Version 52.10 (4); SEMCAD X Version 14.6.14 (7483)

**Pin=50mW/Area Scan (81x81x1):** Interpolated grid: dx=1.200 mm, dy=1.200 mm  
Maximum value of SAR (interpolated) = 4.15 W/kg

**Pin=50mW/Zoom Scan (7x7x7)/Cube 0:** Measurement grid: dx=5mm, dy=5mm, dz=5mm  
Reference Value = 48.18 V/m; Power Drift = 0.09 dB  
Peak SAR (extrapolated) = 5.26 W/kg  
**SAR(1 g) = 2.45 W/kg; SAR(10 g) = 1.15 W/kg** (SAR corrected for target medium)  
Maximum value of SAR (measured) = 4.20 W/kg

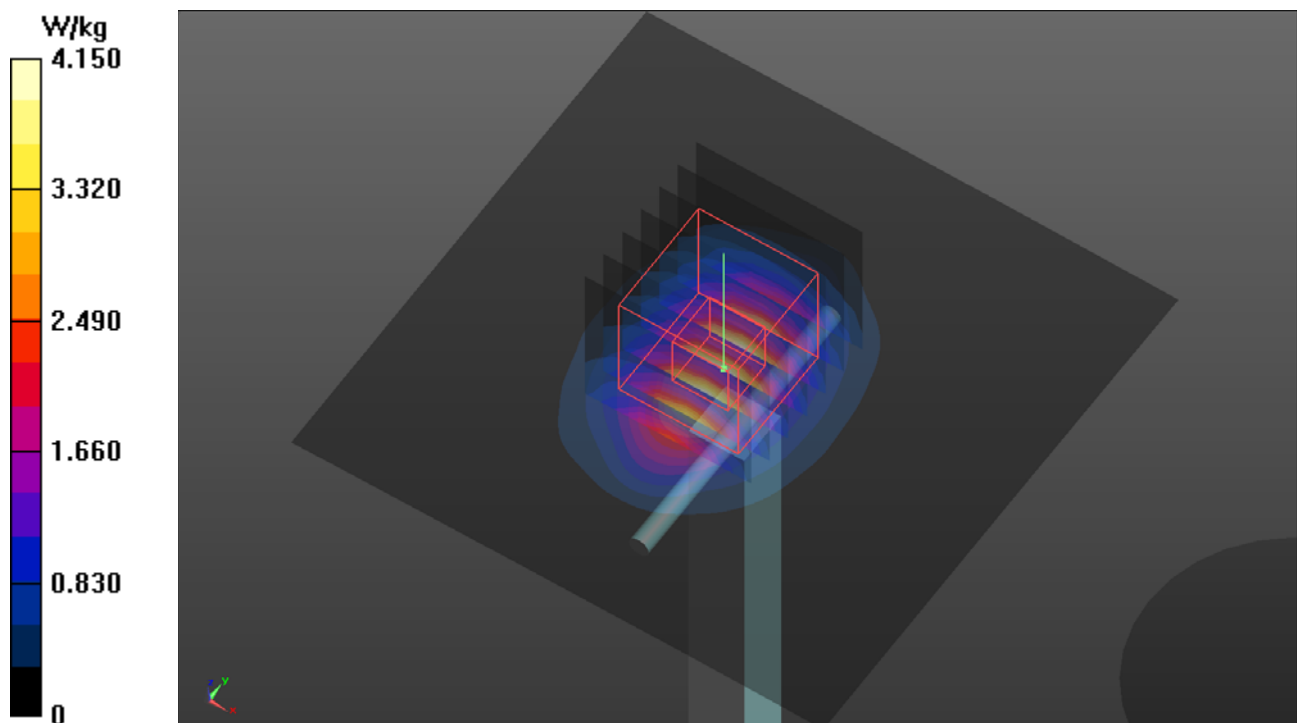

## System Check\_H5250\_200307

**DUT: Dipole 5 GHz; Type: D5GHzV2; SN: 1203**

Communication System: CW; Frequency: 5250 MHz; Duty Cycle: 1:1

Medium: H34T60N1\_0307 Medium parameters used:  $f = 5250$  MHz;  $\sigma = 4.852$  S/m;  $\epsilon_r = 35.71$ ;  $\rho = 1000$  kg/m<sup>3</sup>

Ambient Temperature : 23.6 °C ; Liquid Temperature : 23.3 °C

DASY5 Configuration:

- Probe: EX3DV4 - SN3820; ConvF(4.8, 4.8, 4.8); Calibrated: 2019/06/25
- Sensor-Surface: 1.4mm (Mechanical Surface Detection)
- Electronics: DAE4 Sn916; Calibrated: 2019/12/17
- Phantom: SAM Phantom\_1982; Type: QD 000 P41 Ax; Serial: 1982
- Measurement SW: DASY52, Version 52.10 (4); SEMCAD X Version 14.6.14 (7483)

**Pin=50mW/Area Scan (91x91x1):** Interpolated grid: dx=1.000 mm, dy=1.000 mm  
Maximum value of SAR (interpolated) = 9.50 W/kg

**Pin=50mW/Zoom Scan (7x7x7)/Cube 0:** Measurement grid: dx=4mm, dy=4mm, dz=1.4mm  
Reference Value = 48.72 V/m; Power Drift = -0.02 dB  
Peak SAR (extrapolated) = 16.4 W/kg  
**SAR(1 g) = 4.14 W/kg; SAR(10 g) = 1.19 W/kg** (SAR corrected for target medium)  
Maximum value of SAR (measured) = 10.5 W/kg

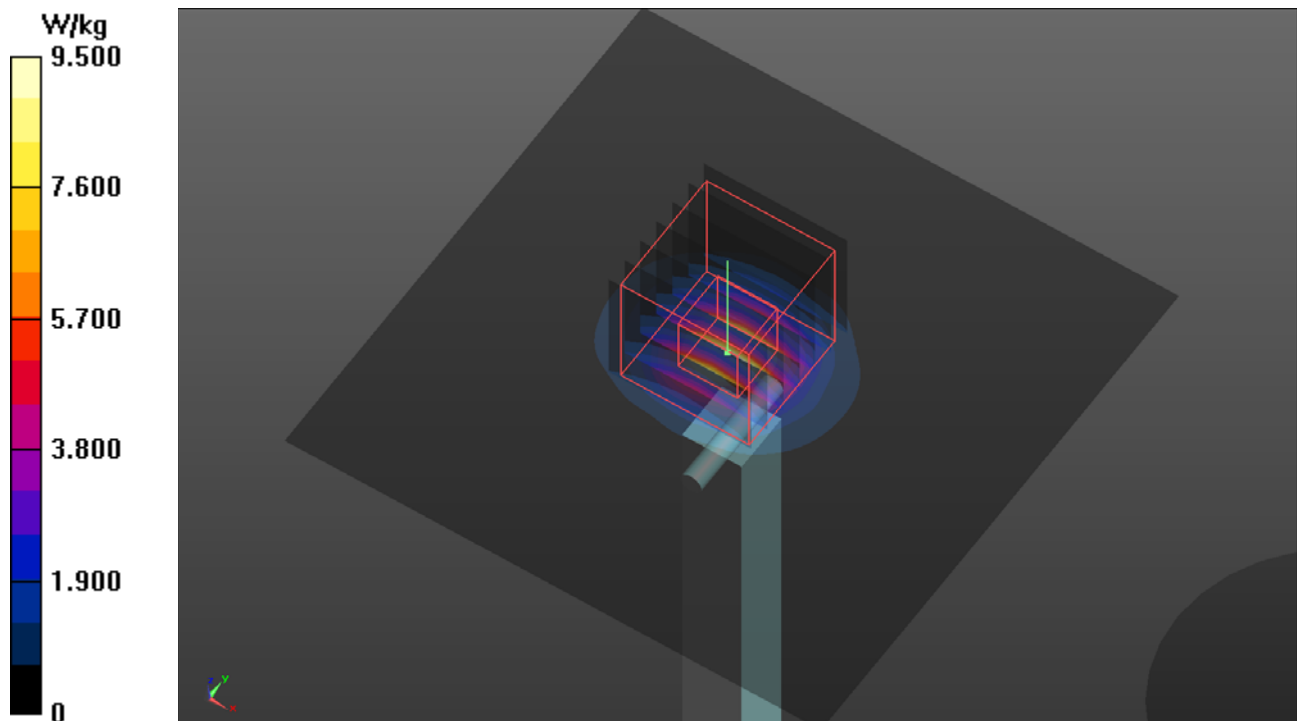

## System Check\_H5600\_200313

**DUT: Dipole 5 GHz; Type: D5GHzV2; SN: 1203**

Communication System: CW; Frequency: 5600 MHz; Duty Cycle: 1:1

Medium: H34T60N1\_0313 Medium parameters used:  $f = 5600$  MHz;  $\sigma = 5.124$  S/m;  $\epsilon_r = 35.657$ ;  $\rho = 1000$  kg/m<sup>3</sup>

Ambient Temperature : 23.6 °C ; Liquid Temperature : 23.4 °C

DASY5 Configuration:

- Probe: EX3DV4 - SN3971; ConvF(4.89, 4.89, 4.89); Calibrated: 2020/01/27
- Sensor-Surface: 1.4mm (Mechanical Surface Detection)
- Electronics: DAE4 Sn1277; Calibrated: 2020/01/24
- Phantom: Twin SAM Phantom\_1823; Type: QD 000 P40 CD; Serial: 1823
- Measurement SW: DASY52, Version 52.10 (4); SEMCAD X Version 14.6.14 (7483)

**Pin=50mW/Area Scan (91x91x1):** Interpolated grid: dx=1.000 mm, dy=1.000 mm  
Maximum value of SAR (interpolated) = 9.85 W/kg

**Pin=50mW/Zoom Scan (7x7x7)/Cube 0:** Measurement grid: dx=4mm, dy=4mm, dz=1.4mm  
Reference Value = 49.91 V/m; Power Drift = 0.03 dB  
Peak SAR (extrapolated) = 17.5 W/kg  
**SAR(1 g) = 4.11 W/kg; SAR(10 g) = 1.17 W/kg** (SAR corrected for target medium)  
Maximum value of SAR (measured) = 10.6 W/kg

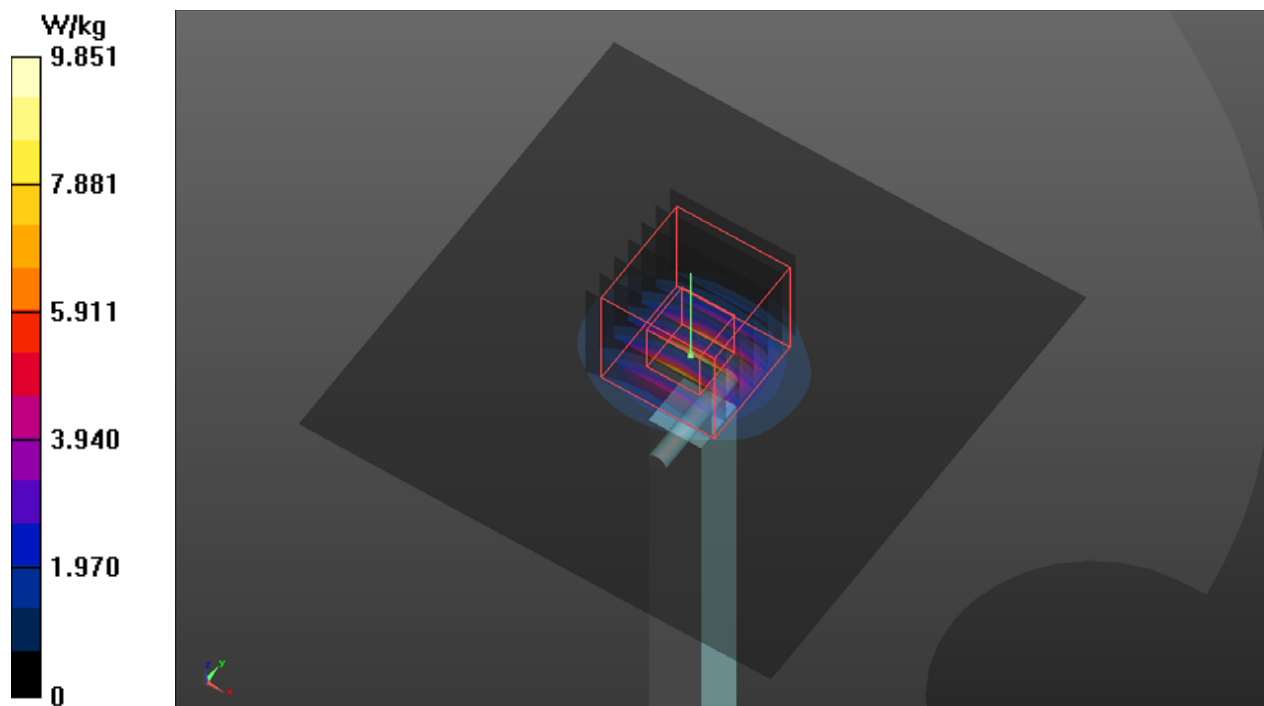

## System Check\_H5750\_200313

**DUT: Dipole 5 GHz; Type: D5GHzV2; SN: 1203**

Communication System: CW; Frequency: 5750 MHz; Duty Cycle: 1:1

Medium: H34T60N1\_0313 Medium parameters used:  $f = 5750$  MHz;  $\sigma = 5.298$  S/m;  $\epsilon_r = 35.4$ ;  $\rho = 1000$  kg/m<sup>3</sup>

Ambient Temperature : 23.6 °C ; Liquid Temperature : 23.4 °C

DASY5 Configuration:

- Probe: EX3DV4 - SN3971; ConvF(5.05, 5.05, 5.05); Calibrated: 2020/01/27
- Sensor-Surface: 1.4mm (Mechanical Surface Detection)
- Electronics: DAE4 Sn1277; Calibrated: 2020/01/24
- Phantom: Twin SAM Phantom\_1823; Type: QD 000 P40 CD; Serial: 1823
- Measurement SW: DASY52, Version 52.10 (4); SEMCAD X Version 14.6.14 (7483)

**Pin=50mW/Area Scan (91x91x1):** Interpolated grid: dx=1.000 mm, dy=1.000 mm  
Maximum value of SAR (interpolated) = 8.94 W/kg

**Pin=50mW/Zoom Scan (7x7x7)/Cube 0:** Measurement grid: dx=4mm, dy=4mm, dz=1.4mm  
Reference Value = 45.03 V/m; Power Drift = -0.14 dB  
Peak SAR (extrapolated) = 16.8 W/kg  
**SAR(1 g) = 3.71 W/kg; SAR(10 g) = 1.06 W/kg** (SAR corrected for target medium)  
Maximum value of SAR (measured) = 9.78 W/kg

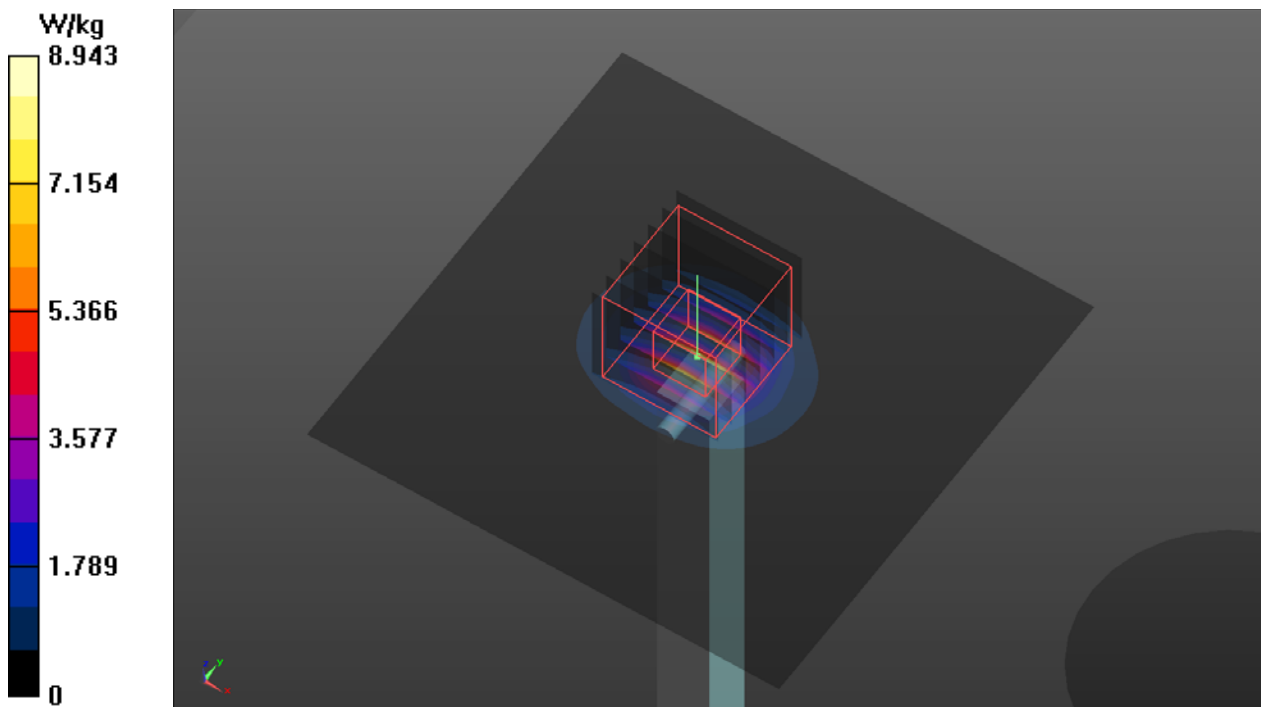

### Appendix B. SAR Plots of SAR Measurement

The SAR plots for highest measured SAR in each exposure configuration, wireless mode and frequency band combination, and measured SAR > 1.5 W/kg are shown as follows.

## P01 WLAN2.4G\_802.11b\_Rear Face\_5mm\_Ch6\_Ant 1

**DUT: 200114E03**

Communication System: IEEE 802.11b WiFi 2.4 GHz (DSSS, 1 Mbps); Frequency: 2437 MHz; Duty Cycle: 1:1

Medium: H19T27N1\_0307 Medium parameters used:  $f = 2437$  MHz;  $\sigma = 1.84$  S/m;  $\epsilon_r = 38.969$ ;  $\rho = 1000$  kg/m<sup>3</sup>

Ambient Temperature : 23.6 °C ; Liquid Temperature : 23.3 °C

DASY5 Configuration:

- Probe: EX3DV4 - SN3820; ConvF(6.95, 6.95, 6.95); Calibrated: 2019/06/25
- Sensor-Surface: 1.4mm (Mechanical Surface Detection)
- Electronics: DAE4 Sn916; Calibrated: 2019/12/17
- Phantom: SAM Phantom\_1982; Type: QD 000 P41 Ax; Serial: 1982
- Measurement SW: DASY52, Version 52.10 (4); SEMCAD X Version 14.6.14 (7483)

- **Area Scan (41x111x1)**: Interpolated grid: dx=1.200 mm, dy=1.200 mm  
Maximum value of SAR (interpolated) = 1.34 W/kg

- **Zoom Scan (7x7x7)/Cube 0**: Measurement grid: dx=5mm, dy=5mm, dz=5mm  
Reference Value = 22.49 V/m; Power Drift = -0.07 dB  
Peak SAR (extrapolated) = 2.28 W/kg  
**SAR(1 g) = 0.720 W/kg; SAR(10 g) = 0.282 W/kg** (SAR corrected for target medium)  
Smallest distance from peaks to all points 3 dB below = 5.1 mm  
Ratio of SAR at M2 to SAR at M1 = 31.8%  
Maximum value of SAR (measured) = 1.65 W/kg

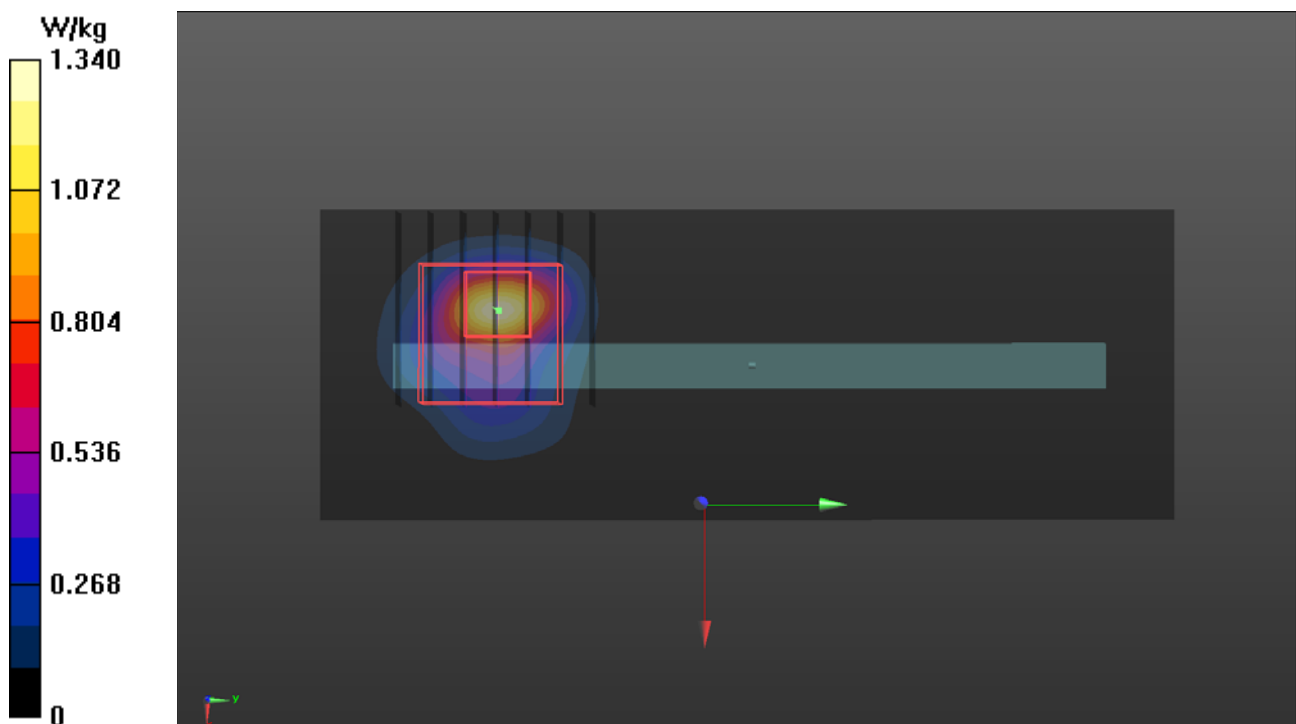

**P02 WLAN5.3G\_802.11a\_Rear Face\_5mm\_Ch64\_Ant0+1****DUT: 200114E03**

Communication System: IEEE 802.11a WiFi 5 GHz (OFDM, 6 Mbps, 96pc duty cycle); Frequency: 5320 MHz; Duty Cycle: 1:1

Medium: H34T60N1\_0313 Medium parameters used:  $f = 5320$  MHz;  $\sigma = 4.79$  S/m;  $\epsilon_r = 36.15$ ;  $\rho = 1000$  kg/m<sup>3</sup>

Ambient Temperature : 23.6 °C ; Liquid Temperature : 23.4 °C

**DASY5 Configuration:**

- Probe: EX3DV4 - SN3971; ConvF(5.28, 5.28, 5.28); Calibrated: 2020/01/27
- Sensor-Surface: 1.4mm (Mechanical Surface Detection)
- Electronics: DAE4 Sn1277; Calibrated: 2020/01/24
- Phantom: Twin SAM Phantom\_1823; Type: QD 000 P40 CD; Serial: 1823
- Measurement SW: DASY52, Version 52.10 (4); SEMCAD X Version 14.6.14 (7483)

- **Area Scan (41x131x1):** Interpolated grid: dx=1.000 mm, dy=1.000 mm  
Maximum value of SAR (interpolated) = 2.17 W/kg

- **Zoom Scan (7x7x7)/Cube 0:** Measurement grid: dx=4mm, dy=4mm, dz=1.4mm  
Reference Value = 23.33 V/m; Power Drift = -0.01 dB  
Peak SAR (extrapolated) = 4.03 W/kg  
**SAR(1 g) = 0.727 W/kg; SAR(10 g) = 0.169 W/kg** (SAR corrected for target medium)  
Smallest distance from peaks to all points 3 dB below = 5.1 mm  
Ratio of SAR at M2 to SAR at M1 = 60.1%  
Maximum value of SAR (measured) = 2.16 W/kg

- **Zoom Scan (7x7x7)/Cube 1:** Measurement grid: dx=4mm, dy=4mm, dz=1.4mm  
Reference Value = 23.33 V/m; Power Drift = -0.01 dB  
Peak SAR (extrapolated) = 2.49 W/kg  
**SAR(1 g) = 0.506 W/kg; SAR(10 g) = 0.129 W/kg** (SAR corrected for target medium)  
Smallest distance from peaks to all points 3 dB below = 6.1 mm  
Ratio of SAR at M2 to SAR at M1 = 61.2%  
Maximum value of SAR (measured) = 1.41 W/kg



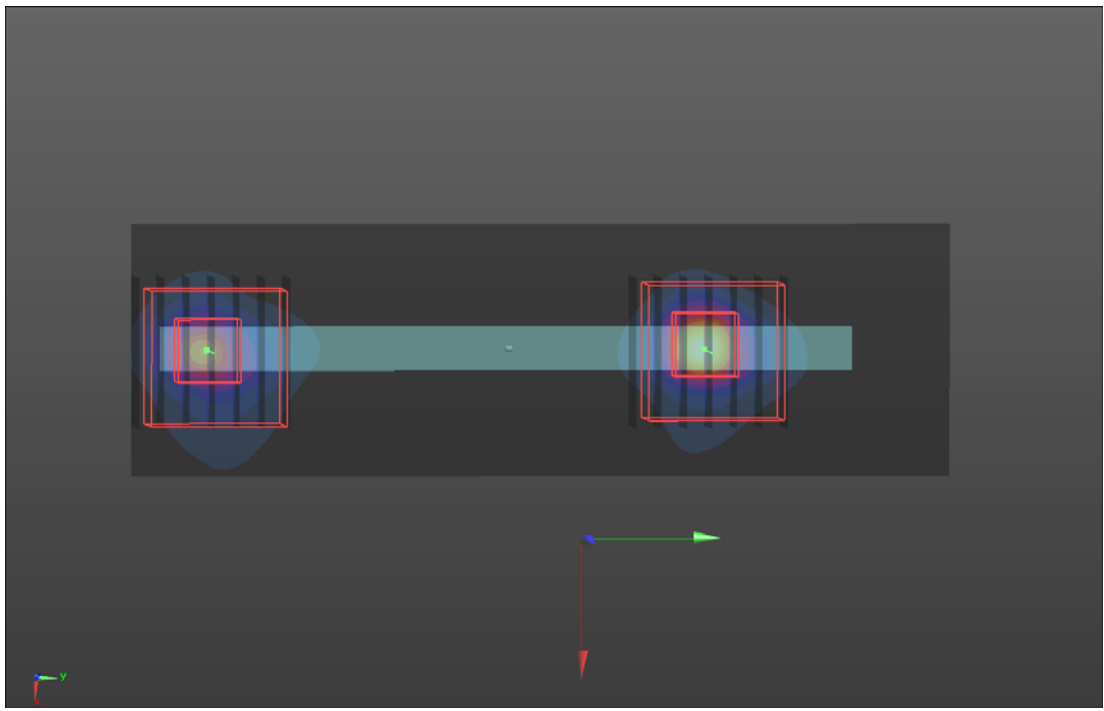
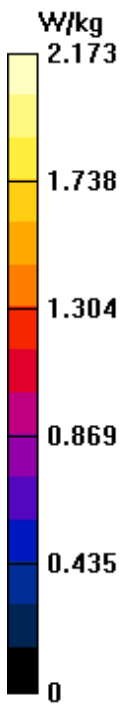

### P03 WLAN5.6G\_802.11a\_Rear Face\_5mm\_Ch132\_Ant0

**DUT: 200114E03**

Communication System: IEEE 802.11a WiFi 5 GHz (OFDM, 6 Mbps, 96pc duty cycle); Frequency: 5660 MHz; Duty Cycle: 1:1

Medium: H34T60N1\_0313 Medium parameters used:  $f = 5660$  MHz;  $\sigma = 5.191$  S/m;  $\epsilon_r = 35.575$ ;  $\rho = 1000$  kg/m<sup>3</sup>

Ambient Temperature : 23.7 °C ; Liquid Temperature : 23.2 °C

#### DASY5 Configuration:

- Probe: EX3DV4 - SN3971; ConvF(4.89, 4.89, 4.89); Calibrated: 2020/01/27
- Sensor-Surface: 1.4mm (Mechanical Surface Detection)
- Electronics: DAE4 Sn1277; Calibrated: 2020/01/24
- Phantom: Twin SAM Phantom\_1823; Type: QD 000 P40 CD; Serial: 1823
- Measurement SW: DASY52, Version 52.10 (4); SEMCAD X Version 14.6.14 (7483)

- **Area Scan (41x131x1)**: Interpolated grid: dx=1.000 mm, dy=1.000 mm  
Maximum value of SAR (interpolated) = 2.55 W/kg

- **Zoom Scan (7x7x7)/Cube 0**: Measurement grid: dx=4mm, dy=4mm, dz=1.4mm  
Reference Value = 24.22 V/m; Power Drift = 0.09 dB

Peak SAR (extrapolated) = 5.01 W/kg

**SAR(1 g) = 0.787 W/kg; SAR(10 g) = 0.191 W/kg** (SAR corrected for target medium)

Smallest distance from peaks to all points 3 dB below = 4.7 mm

Ratio of SAR at M2 to SAR at M1 = 54.2%

Maximum value of SAR (measured) = 2.32 W/kg

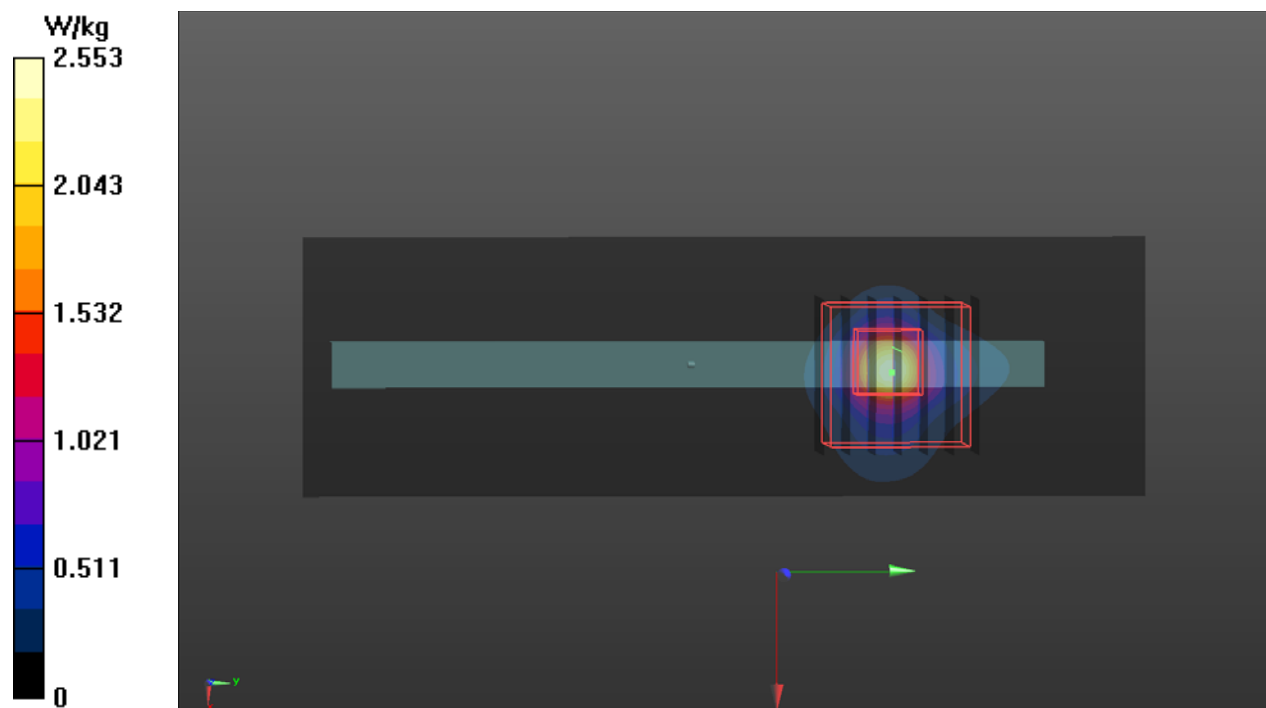

**P04 WLAN5.8G\_802.11a\_Rear Face\_5mm\_Ch149\_Ant0+1****DUT: 200114E03**

Communication System: IEEE 802.11a WiFi 5 GHz (OFDM, 6 Mbps, 96pc duty cycle); Frequency: 5745 MHz; Duty Cycle: 1:1

Medium: H34T60N1\_0312 Medium parameters used:  $f = 5745$  MHz;  $\sigma = 5.391$  S/m;  $\epsilon_r = 35.881$ ;  $\rho = 1000$  kg/m<sup>3</sup>

Ambient Temperature : 23.7 °C ; Liquid Temperature : 23.2 °C

**DASY5 Configuration:**

- Probe: EX3DV4 - SN3971; ConvF(5.05, 5.05, 5.05); Calibrated: 2020/01/27
- Sensor-Surface: 1.4mm (Mechanical Surface Detection)
- Electronics: DAE4 Sn1277; Calibrated: 2020/01/24
- Phantom: Twin SAM Phantom\_1823; Type: QD 000 P40 CD; Serial: 1823
- Measurement SW: DASY52, Version 52.10 (4); SEMCAD X Version 14.6.14 (7483)

- **Area Scan (41x131x1):** Interpolated grid: dx=1.000 mm, dy=1.000 mm  
Maximum value of SAR (interpolated) = 2.39 W/kg

- **Zoom Scan (7x7x7)/Cube 0:** Measurement grid: dx=4mm, dy=4mm, dz=1.4mm  
Reference Value = 20.95 V/m; Power Drift = 0.03 dB  
Peak SAR (extrapolated) = 4.88 W/kg  
**SAR(1 g) = 0.769 W/kg; SAR(10 g) = 0.175 W/kg** (SAR corrected for target medium)  
Smallest distance from peaks to all points 3 dB below = 5.1 mm  
Ratio of SAR at M2 to SAR at M1 = 56%  
Maximum value of SAR (measured) = 2.34 W/kg

- **Zoom Scan (7x7x7)/Cube 1:** Measurement grid: dx=4mm, dy=4mm, dz=1.4mm  
Reference Value = 20.95 V/m; Power Drift = 0.03 dB  
Peak SAR (extrapolated) = 4.68 W/kg  
**SAR(1 g) = 0.709 W/kg; SAR(10 g) = 0.167 W/kg** (SAR corrected for target medium)  
Smallest distance from peaks to all points 3 dB below = 4.6 mm  
Ratio of SAR at M2 to SAR at M1 = 57.7%  
Maximum value of SAR (measured) = 2.42 W/kg

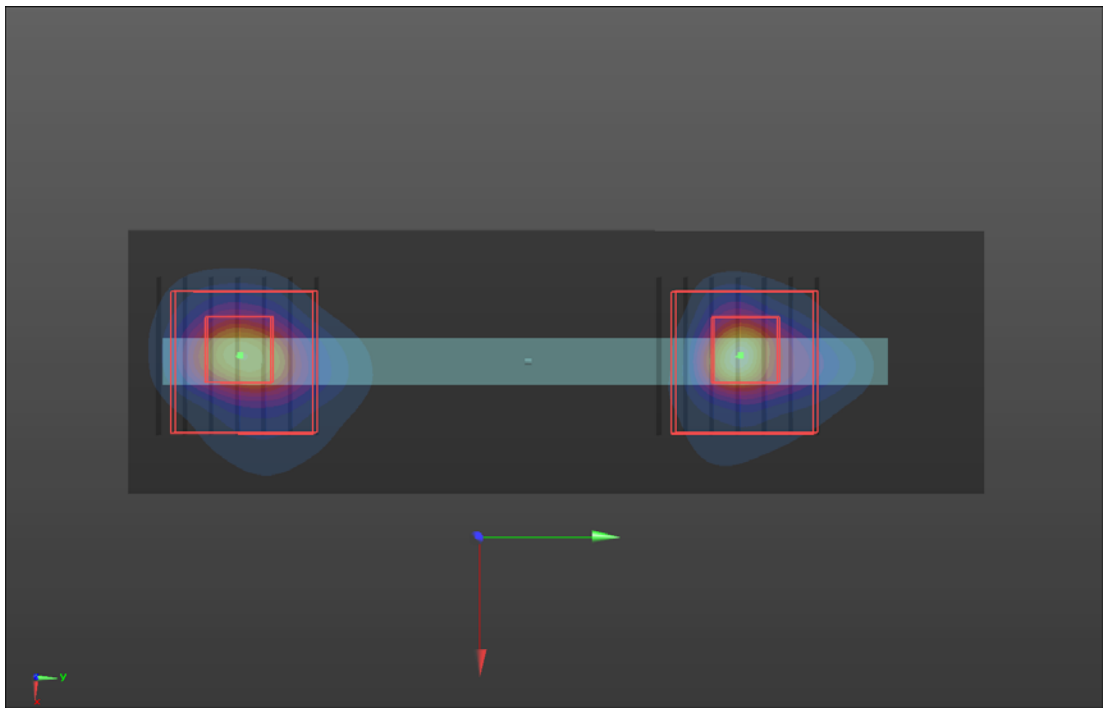
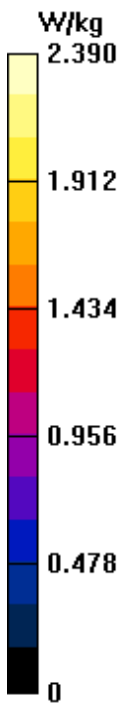

## P05 BT\_BDR\_Rear Face\_5mm\_Ch78\_Ant 0

**DUT: 200114E03**

Communication System: IEEE 802.15.1 Bluetooth (GFSK, DH5); Frequency: 2480 MHz; Duty Cycle: 1:1

Medium: H19T27N1\_0314 Medium parameters used:  $f = 2480$  MHz;  $\sigma = 1.914$  S/m;  $\epsilon_r = 38.11$ ;  $\rho = 1000$  kg/m<sup>3</sup>

Ambient Temperature : 23.6 °C ; Liquid Temperature : 23.3 °C

DASY5 Configuration:

- Probe: EX3DV4 - SN3971; ConvF(8, 8, 8); Calibrated: 2020/01/27
- Sensor-Surface: 1.4mm (Mechanical Surface Detection)
- Electronics: DAE4 Sn1277; Calibrated: 2020/01/24
- Phantom: Twin SAM Phantom\_1823; Type: QD 000 P40 CD; Serial: 1823
- Measurement SW: DASY52, Version 52.10 (4); SEMCAD X Version 14.6.14 (7483)

- **Area Scan (41x111x1)**: Interpolated grid: dx=1.200 mm, dy=1.200 mm

Maximum value of SAR (interpolated) = 0.144 W/kg

- **Zoom Scan (7x7x7)/Cube 0**: Measurement grid: dx=5mm, dy=5mm, dz=5mm

Reference Value = 7.838 V/m; Power Drift = 0.07 dB

Peak SAR (extrapolated) = 0.259 W/kg

**SAR(1 g) = 0.085 W/kg; SAR(10 g) = 0.035 W/kg** (SAR corrected for target medium)

Smallest distance from peaks to all points 3 dB below = 5.1 mm

Ratio of SAR at M2 to SAR at M1 = 30.5%

Maximum value of SAR (measured) = 0.172 W/kg

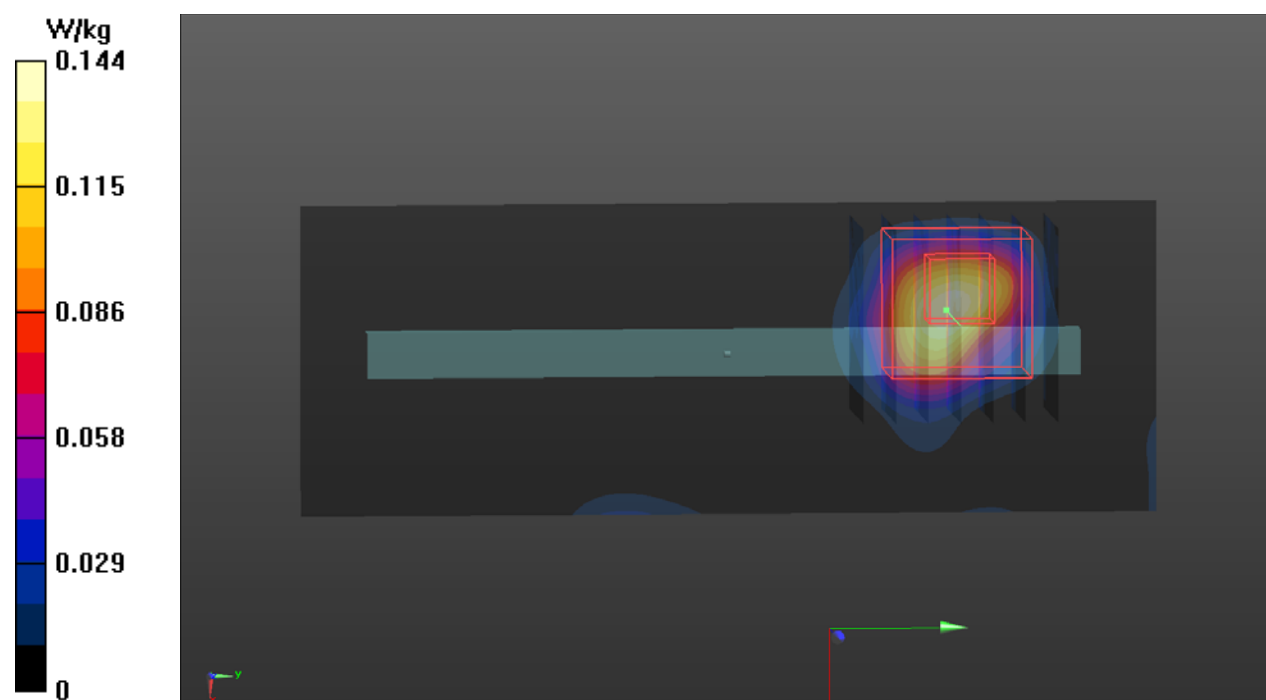

### Appendix C. Calibration Certificate for Probe and Dipole

The SPEAG calibration certificates are shown as follows.



Accredited by the Swiss Accreditation Service (SAS)  
The Swiss Accreditation Service is one of the signatories to the EA  
Multilateral Agreement for the recognition of calibration certificates

Accreditation No.: **SCS 0108**

Client **B.V. ADT (Auden)**

Certificate No: **D2450V2-737\_Aug19**

## CALIBRATION CERTIFICATE

Object **D2450V2 - SN:737**

Calibration procedure(s) **QA CAL-05.v11  
Calibration Procedure for SAR Validation Sources between 0.7-3 GHz**

Calibration date: **August 26, 2019**

This calibration certificate documents the traceability to national standards, which realize the physical units of measurements (SI).  
The measurements and the uncertainties with confidence probability are given on the following pages and are part of the certificate.

All calibrations have been conducted in the closed laboratory facility: environment temperature ( $22 \pm 3$ )°C and humidity < 70%.

Calibration Equipment used (M&TE critical for calibration)

| Primary Standards               | ID #               | Cal Date (Certificate No.)        | Scheduled Calibration  |
|---------------------------------|--------------------|-----------------------------------|------------------------|
| Power meter NRP                 | SN: 104778         | 03-Apr-19 (No. 217-02892/02893)   | Apr-20                 |
| Power sensor NRP-Z91            | SN: 103244         | 03-Apr-19 (No. 217-02892)         | Apr-20                 |
| Power sensor NRP-Z91            | SN: 103245         | 03-Apr-19 (No. 217-02893)         | Apr-20                 |
| Reference 20 dB Attenuator      | SN: 5058 (20k)     | 04-Apr-19 (No. 217-02894)         | Apr-20                 |
| Type-N mismatch combination     | SN: 5047.2 / 06327 | 04-Apr-19 (No. 217-02895)         | Apr-20                 |
| Reference Probe EX3DV4          | SN: 7349           | 29-May-19 (No. EX3-7349_May19)    | May-20                 |
| DAE4                            | SN: 601            | 30-Apr-19 (No. DAE4-601_Apr19)    | Apr-20                 |
| Secondary Standards             | ID #               | Check Date (in house)             | Scheduled Check        |
| Power meter E4419B              | SN: GB39512475     | 30-Oct-14 (in house check Feb-19) | In house check: Oct-20 |
| Power sensor HP 8481A           | SN: US37292783     | 07-Oct-15 (in house check Oct-18) | In house check: Oct-20 |
| Power sensor HP 8481A           | SN: MY41092317     | 07-Oct-15 (in house check Oct-18) | In house check: Oct-20 |
| RF generator R&S SMT-06         | SN: 100972         | 15-Jun-15 (in house check Oct-18) | In house check: Oct-20 |
| Network Analyzer Agilent E8358A | SN: US41080477     | 31-Mar-14 (in house check Oct-18) | In house check: Oct-19 |

Calibrated by: **Michael Weber**      **Michael Weber**      **Laboratory Technician**

Approved by: **Katja Pokovic**      **Katja Pokovic**      **Technical Manager**

Signature  
*M. Weber*

*Katja Pokovic*

Issued: August 26, 2019

This calibration certificate shall not be reproduced except in full without written approval of the laboratory.



Accredited by the Swiss Accreditation Service (SAS)

The Swiss Accreditation Service is one of the signatories to the EA  
Multilateral Agreement for the recognition of calibration certificates

Accreditation No.: **SCS 0108**

### Glossary:

|       |                                 |
|-------|---------------------------------|
| TSL   | tissue simulating liquid        |
| ConvF | sensitivity in TSL / NORM x,y,z |
| N/A   | not applicable or not measured  |

### Calibration is Performed According to the Following Standards:

- IEEE Std 1528-2013, "IEEE Recommended Practice for Determining the Peak Spatial-Averaged Specific Absorption Rate (SAR) in the Human Head from Wireless Communications Devices: Measurement Techniques", June 2013
- IEC 62209-1, "Measurement procedure for the assessment of Specific Absorption Rate (SAR) from hand-held and body-mounted devices used next to the ear (frequency range of 300 MHz to 6 GHz)", July 2016
- IEC 62209-2, "Procedure to determine the Specific Absorption Rate (SAR) for wireless communication devices used in close proximity to the human body (frequency range of 30 MHz to 6 GHz)", March 2010
- KDB 865664, "SAR Measurement Requirements for 100 MHz to 6 GHz"

### Additional Documentation:

- DASY4/5 System Handbook

### Methods Applied and Interpretation of Parameters:

- Measurement Conditions:** Further details are available from the Validation Report at the end of the certificate. All figures stated in the certificate are valid at the frequency indicated.
- Antenna Parameters with TSL:** The dipole is mounted with the spacer to position its feed point exactly below the center marking of the flat phantom section, with the arms oriented parallel to the body axis.
- Feed Point Impedance and Return Loss:** These parameters are measured with the dipole positioned under the liquid filled phantom. The impedance stated is transformed from the measurement at the SMA connector to the feed point. The Return Loss ensures low reflected power. No uncertainty required.
- Electrical Delay:** One-way delay between the SMA connector and the antenna feed point. No uncertainty required.
- SAR measured:** SAR measured at the stated antenna input power.
- SAR normalized:** SAR as measured, normalized to an input power of 1 W at the antenna connector.
- SAR for nominal TSL parameters:** The measured TSL parameters are used to calculate the nominal SAR result.

The reported uncertainty of measurement is stated as the standard uncertainty of measurement multiplied by the coverage factor  $k=2$ , which for a normal distribution corresponds to a coverage probability of approximately 95%.



## Measurement Conditions

DASY system configuration, as far as not given on page 1.

|                                     |                        |             |
|-------------------------------------|------------------------|-------------|
| <b>DASY Version</b>                 | DASY5                  | V52.10.2    |
| <b>Extrapolation</b>                | Advanced Extrapolation |             |
| <b>Phantom</b>                      | Modular Flat Phantom   |             |
| <b>Distance Dipole Center - TSL</b> | 10 mm                  | with Spacer |
| <b>Zoom Scan Resolution</b>         | dx, dy, dz = 5 mm      |             |
| <b>Frequency</b>                    | 2450 MHz ± 1 MHz       |             |

## Head TSL parameters

The following parameters and calculations were applied.

|  | Temperature     | Permittivity | Conductivity     |
|--|-----------------|--------------|------------------|
| <b>Nominal Head TSL parameters</b>             | 22.0 °C         | 39.2         | 1.80 mho/m       |
| <b>Measured Head TSL parameters</b>            | (22.0 ± 0.2) °C | 37.8 ± 6 %   | 1.83 mho/m ± 6 % |
| <b>Head TSL temperature change during test</b> | < 0.5 °C        | ----         | ----             |

## SAR result with Head TSL

| <b>SAR averaged over 1 cm<sup>3</sup> (1 g) of Head TSL</b> | Condition          |                                 |
|---|--------------------|---------------------------------|
| SAR measured  | 250 mW input power | 13.4 W/kg                       |
| SAR for nominal Head TSL parameters                         | normalized to 1W   | <b>52.7 W/kg ± 17.0 % (k=2)</b> |

| <b>SAR averaged over 10 cm<sup>3</sup> (10 g) of Head TSL</b> | condition          |                                 |
|---|--------------------|---------------------------------|
| SAR measured  | 250 mW input power | 6.20 W/kg                       |
| SAR for nominal Head TSL parameters                           | normalized to 1W   | <b>24.5 W/kg ± 16.5 % (k=2)</b> |

## Appendix (Additional assessments outside the scope of SCS 0108)

### Antenna Parameters with Head TSL

|                                      |                               |
|--------------------------------------|-------------------------------|
| Impedance, transformed to feed point | 54.3 $\Omega$ + 4.5 $j\Omega$ |
| Return Loss                          | - 24.5 dB                     |

### General Antenna Parameters and Design

|                                  |          |
|----------------------------------|----------|
| Electrical Delay (one direction) | 1.162 ns |
|----------------------------------|----------|

After long term use with 100W radiated power, only a slight warming of the dipole near the feedpoint can be measured.

The dipole is made of standard semirigid coaxial cable. The center conductor of the feeding line is directly connected to the second arm of the dipole. The antenna is therefore short-circuited for DC-signals. On some of the dipoles, small end caps are added to the dipole arms in order to improve matching when loaded according to the position as explained in the "Measurement Conditions" paragraph. The SAR data are not affected by this change. The overall dipole length is still according to the Standard.

No excessive force must be applied to the dipole arms, because they might bend or the soldered connections near the feedpoint may be damaged.

### Additional EUT Data

|                 |       |
|-----------------|-------|
| Manufactured by | SPEAG |
|-----------------|-------|

## DASY5 Validation Report for Head TSL

Date: 26.08.2019

Test Laboratory: SPEAG, Zurich, Switzerland

**DUT: Dipole 2450 MHz; Type: D2450V2; Serial: D2450V2 - SN:737**

Communication System: UID 0 - CW; Frequency: 2450 MHz

Medium parameters used:  $f = 2450$  MHz;  $\sigma = 1.83$  S/m;  $\epsilon_r = 37.8$ ;  $\rho = 1000$  kg/m<sup>3</sup>

Phantom section: Flat Section

Measurement Standard: DASY5 (IEEE/IEC/ANSI C63.19-2011)

DASY52 Configuration:

- Probe: EX3DV4 - SN7349; ConvF(7.9, 7.9, 7.9) @ 2450 MHz; Calibrated: 29.05.2019
- Sensor-Surface: 1.4mm (Mechanical Surface Detection)
- Electronics: DAE4 Sn601; Calibrated: 30.04.2019
- Phantom: Flat Phantom 5.0 (front); Type: QD 000 P50 AA; Serial: 1001
- DASY52 52.10.2(1504); SEMCAD X 14.6.12(7470)

### **Dipole Calibration for Head Tissue/Pin=250 mW, d=10mm/Zoom Scan (7x7x7)/Cube 0:**

Measurement grid: dx=5mm, dy=5mm, dz=5mm

Reference Value = 117.9 V/m; Power Drift = 0.00 dB

Peak SAR (extrapolated) = 26.7 W/kg

**SAR(1 g) = 13.4 W/kg; SAR(10 g) = 6.2 W/kg**

Maximum value of SAR (measured) = 22.1 W/kg

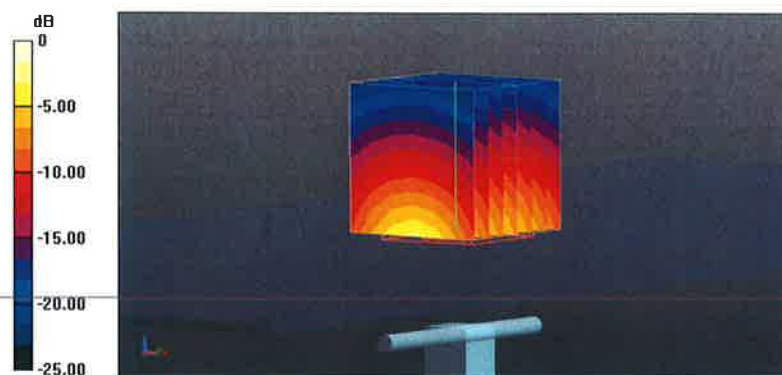

0 dB = 22.1 W/kg = 13.44 dBW/kg

# Impedance Measurement Plot for Head TSL

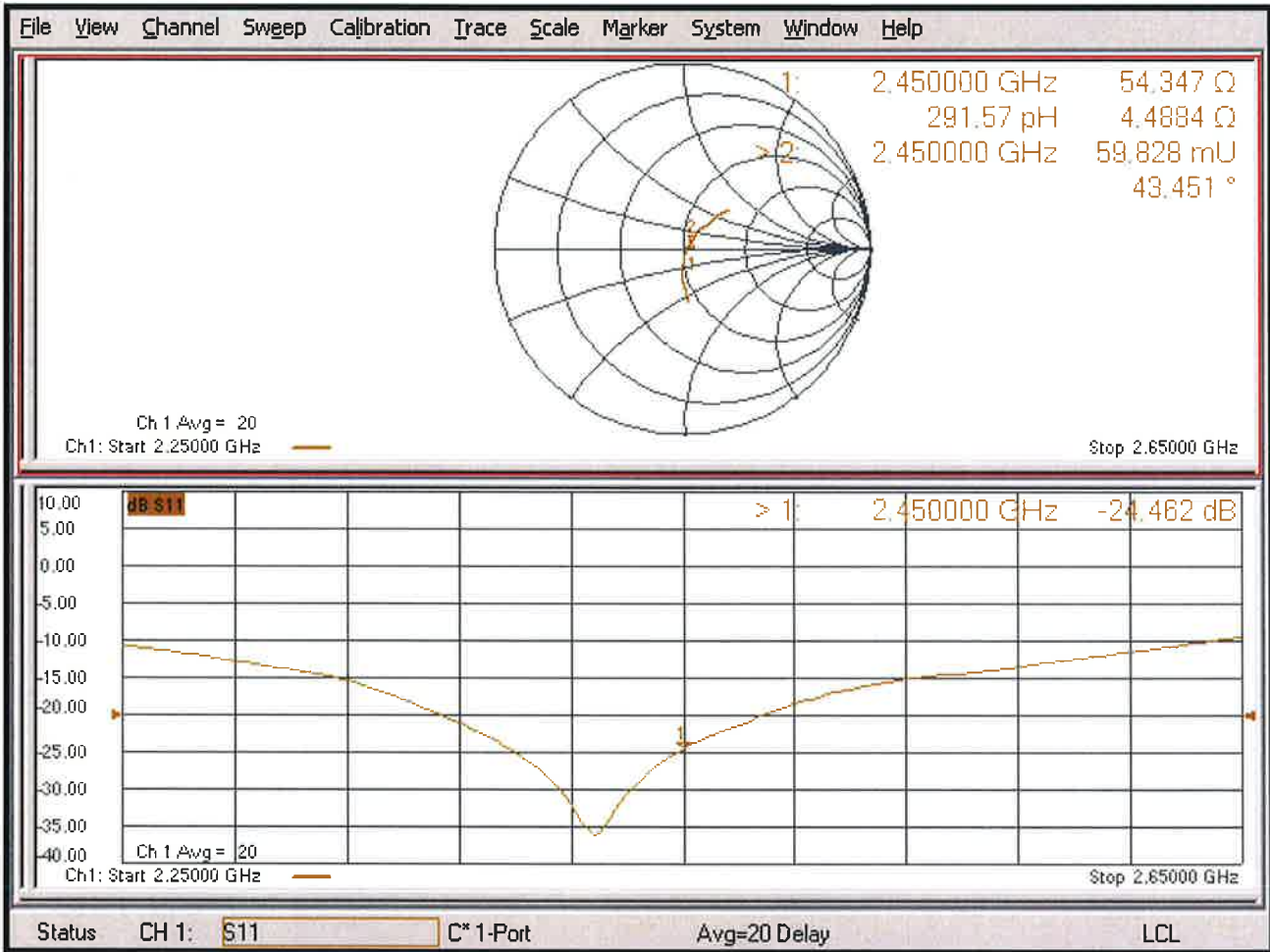

Client **AUDEN**

Certificate No: **Z19-60452**

## CALIBRATION CERTIFICATE

Object **D5GHzV2 - SN: 1203**

Calibration Procedure(s) **FF-Z11-003-01  
Calibration Procedures for dipole validation kits**



Calibration date: **December 20, 2019**

This calibration Certificate documents the traceability to national standards, which realize the physical units of measurements(SI). The measurements and the uncertainties with confidence probability are given on the following pages and are part of the certificate.

All calibrations have been conducted in the closed laboratory facility: environment temperature(22±3)°C and humidity<70%.

Calibration Equipment used (M&TE critical for calibration)

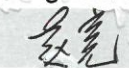
| Primary Standards       | ID #       | Cal Date(Calibrated by, Certificate No.) | Scheduled Calibration |
|-------------------------|------------|--|-----------------------|
| Power Meter NRP2        | 106276     | 11-Apr-19 (CTTL, No.J19X02605)           | Apr-20                |
| Power sensor NRP6A      | 101369     | 11-Apr-19 (CTTL, No.J19X02605)           | Apr-20                |
| ReferenceProbe EX3DV4   | SN 3617    | 31-Jan-19(SPEAG,No.EX3-3617_Jan19)       | Jan-20                |
| DAE4                    | SN 1555    | 22-Aug-19(CTTL-SPEAG,No.Z19-60295)       | Aug-20                |
| Secondary Standards     | ID #       | Cal Date(Calibrated by, Certificate No.) | Scheduled Calibration |
| Signal Generator E4438C | MY49071430 | 23-Jan-19 (CTTL, No.J19X00336)           | Jan-20                |
| NetworkAnalyzerE5071C   | MY46110673 | 24-Jan-19 (CTTL, No.J19X00547)           | Jan-20                |

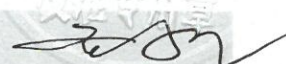
|                | Name        | Function           | Signature   |
|----------------|-------------|--------------------|---|
| Calibrated by: | Zhao Jing   | SAR Test Engineer  |  |
| Reviewed by:   | Lin Hao     | SAR Test Engineer  |  |
| Approved by:   | Qi Dianyuan | SAR Project Leader |  |

Issued: December 24, 2019

This calibration certificate shall not be reproduced except in full without written approval of the laboratory.





### Glossary:

|       |  |
|-------|--|
| TSL   | tissue simulating liquid                   |
| ConvF | sensitivity in TSL / NORM <sub>x,y,z</sub> |
| N/A   | not applicable or not measured             |

### Calibration is Performed According to the Following Standards:

- IEEE Std 1528-2013, "IEEE Recommended Practice for Determining the Peak Spatial-Averaged Specific Absorption Rate (SAR) in the Human Head from Wireless Communications Devices: Measurement Techniques", June 2013
- IEC 62209-1, "Measurement procedure for assessment of specific absorption rate of human exposure to radio frequency fields from hand-held and body-mounted wireless communication devices- Part 1: Device used next to the ear (Frequency range of 300MHz to 6GHz)", July 2016
- IEC 62209-2, "Procedure to measure the Specific Absorption Rate (SAR) For wireless communication devices used in close proximity to the human body (frequency range of 30MHz to 6GHz)", March 2010
- KDB865664, SAR Measurement Requirements for 100 MHz to 6 GHz

### Additional Documentation:

- DASY4/5 System Handbook

### Methods Applied and Interpretation of Parameters:

- Measurement Conditions:** Further details are available from the Validation Report at the end of the certificate. All figures stated in the certificate are valid at the frequency indicated.
- Antenna Parameters with TSL:** The dipole is mounted with the spacer to position its feed point exactly below the center marking of the flat phantom section, with the arms oriented parallel to the body axis.
- Feed Point Impedance and Return Loss:** These parameters are measured with the dipole positioned under the liquid filled phantom. The impedance stated is transformed from the measurement at the SMA connector to the feed point. The Return Loss ensures low reflected power. No uncertainty required.
- Electrical Delay:** One-way delay between the SMA connector and the antenna feed point. No uncertainty required.
- SAR measured:** SAR measured at the stated antenna input power.
- SAR normalized:** SAR as measured, normalized to an input power of 1 W at the antenna connector.
- SAR for nominal TSL parameters:** The measured TSL parameters are used to calculate the nominal SAR result.

The reported uncertainty of measurement is stated as the standard uncertainty of Measurement multiplied by the coverage factor  $k=2$ , which for a normal distribution Corresponds to a coverage probability of approximately 95%.



Add: No.51 Xueyuan Road, Haidian District, Beijing, 100191, China  
 Tel: +86-10-62304633-2512 Fax: +86-10-62304633-2504  
 E-mail: cttl@chinattl.com http://www.chinattl.cn

### Measurement Conditions

DASY system configuration, as far as not given on page 1.

|                                     |  |                                  |
|-------------------------------------|--|----------------------------------|
| <b>DASY Version</b>                 | DASY52   | V52.10.3                         |
| <b>Extrapolation</b>                | Advanced Extrapolation                                   |                                  |
| <b>Phantom</b>                      | Triple Flat Phantom 5.1C                                 |                                  |
| <b>Distance Dipole Center - TSL</b> | 10 mm  | with Spacer                      |
| <b>Zoom Scan Resolution</b>         | dx, dy = 4 mm, dz = 1.4 mm                               | Graded Ratio = 1.4 (Z direction) |
| <b>Frequency</b>                    | 5250 MHz ± 1 MHz<br>5600 MHz ± 1 MHz<br>5750 MHz ± 1 MHz |                                  |

### Head TSL parameters at 5250 MHz

The following parameters and calculations were applied.

|  | Temperature     | Permittivity | Conductivity     |
|--|-----------------|--------------|------------------|
| <b>Nominal Head TSL parameters</b>             | 22.0 °C         | 35.9         | 4.71 mho/m       |
| <b>Measured Head TSL parameters</b>            | (22.0 ± 0.2) °C | 36.3 ± 6 %   | 4.69 mho/m ± 6 % |
| <b>Head TSL temperature change during test</b> | <1.0 °C         | ----         | ----             |

### SAR result with Head TSL at 5250 MHz

|   |                    |                                 |
|---|--------------------|---------------------------------|
| <b>SAR averaged over 1 cm<sup>3</sup> (1 g) of Head TSL</b>   | Condition          |                                 |
| SAR measured  | 100 mW input power | 7.53 W/kg                       |
| SAR for nominal Head TSL parameters                           | normalized to 1W   | <b>75.5 W/kg ± 24.4 % (k=2)</b> |
| <b>SAR averaged over 10 cm<sup>3</sup> (10 g) of Head TSL</b> | Condition          |                                 |
| SAR measured  | 100 mW input power | 2.14 W/kg                       |
| SAR for nominal Head TSL parameters                           | normalized to 1W   | <b>21.5 W/kg ± 24.2 % (k=2)</b> |





Add: No.51 Xueyuan Road, Haidian District, Beijing, 100191, China  
 Tel: +86-10-62304633-2512 Fax: +86-10-62304633-2504  
 E-mail: cttl@chinattl.com http://www.chinattl.cn

### Head TSL parameters at 5600 MHz

The following parameters and calculations were applied.

|  | Temperature     | Permittivity | Conductivity     |
|--|-----------------|--------------|------------------|
| <b>Nominal Head TSL parameters</b>             | 22.0 °C         | 35.5         | 5.07 mho/m       |
| <b>Measured Head TSL parameters</b>            | (22.0 ± 0.2) °C | 35.7 ± 6 %   | 5.07 mho/m ± 6 % |
| <b>Head TSL temperature change during test</b> | <1.0 °C         | ----         | ----             |

### SAR result with Head TSL at 5600 MHz

|   |                    |                                 |
|---|--------------------|---------------------------------|
| <b>SAR averaged over 1 cm<sup>3</sup> (1 g) of Head TSL</b>   | Condition          |                                 |
| SAR measured  | 100 mW input power | 7.99 W/kg                       |
| SAR for nominal Head TSL parameters                           | normalized to 1W   | <b>80.0 W/kg ± 24.4 % (k=2)</b> |
| <b>SAR averaged over 10 cm<sup>3</sup> (10 g) of Head TSL</b> | Condition          |                                 |
| SAR measured  | 100 mW input power | 2.28 W/kg                       |
| SAR for nominal Head TSL parameters                           | normalized to 1W   | <b>22.8 W/kg ± 24.2 % (k=2)</b> |

### Head TSL parameters at 5750 MHz

The following parameters and calculations were applied.

|  | Temperature     | Permittivity | Conductivity     |
|--|-----------------|--------------|------------------|
| <b>Nominal Head TSL parameters</b>             | 22.0 °C         | 35.4         | 5.22 mho/m       |
| <b>Measured Head TSL parameters</b>            | (22.0 ± 0.2) °C | 35.5 ± 6 %   | 5.23 mho/m ± 6 % |
| <b>Head TSL temperature change during test</b> | <1.0 °C         | ----         | ----             |

### SAR result with Head TSL at 5750 MHz

|   |                    |                                 |
|---|--------------------|---------------------------------|
| <b>SAR averaged over 1 cm<sup>3</sup> (1 g) of Head TSL</b>   | Condition          |                                 |
| SAR measured  | 100 mW input power | 7.78 W/kg                       |
| SAR for nominal Head TSL parameters                           | normalized to 1W   | <b>77.8 W/kg ± 24.4 % (k=2)</b> |
| <b>SAR averaged over 10 cm<sup>3</sup> (10 g) of Head TSL</b> | Condition          |                                 |
| SAR measured  | 100 mW input power | 2.21 W/kg                       |
| SAR for nominal Head TSL parameters                           | normalized to 1W   | <b>22.1 W/kg ± 24.2 % (k=2)</b> |





Add: No.51 Xueyuan Road, Haidian District, Beijing, 100191, China  
 Tel: +86-10-62304633-2512 Fax: +86-10-62304633-2504  
 E-mail: cttl@chinattl.com http://www.chinattl.cn

### Body TSL parameters at 5250 MHz

The following parameters and calculations were applied.

|  | Temperature     | Permittivity | Conductivity     |
|--|-----------------|--------------|------------------|
| <b>Nominal Body TSL parameters</b>             | 22.0 °C         | 48.9         | 5.36 mho/m       |
| <b>Measured Body TSL parameters</b>            | (22.0 ± 0.2) °C | 49.1 ± 6 %   | 5.23 mho/m ± 6 % |
| <b>Body TSL temperature change during test</b> | <1.0 °C         | ----         | ----             |

### SAR result with Body TSL at 5250 MHz

|   |                    |                                 |
|---|--------------------|---------------------------------|
| <b>SAR averaged over 1 cm<sup>3</sup> (1 g) of Body TSL</b>   | Condition          |                                 |
| SAR measured  | 100 mW input power | 7.29 W/kg                       |
| SAR for nominal Body TSL parameters                           | normalized to 1W   | <b>72.9 W/kg ± 24.4 % (k=2)</b> |
| <b>SAR averaged over 10 cm<sup>3</sup> (10 g) of Body TSL</b> | Condition          |                                 |
| SAR measured  | 100 mW input power | 2.05 W/kg                       |
| SAR for nominal Body TSL parameters                           | normalized to 1W   | <b>20.5 W/kg ± 24.2 % (k=2)</b> |

### Body TSL parameters at 5600 MHz

The following parameters and calculations were applied.

|  | Temperature     | Permittivity | Conductivity     |
|--|-----------------|--------------|------------------|
| <b>Nominal Body TSL parameters</b>             | 22.0 °C         | 48.5         | 5.77 mho/m       |
| <b>Measured Body TSL parameters</b>            | (22.0 ± 0.2) °C | 48.4 ± 6 %   | 5.70 mho/m ± 6 % |
| <b>Body TSL temperature change during test</b> | <1.0 °C         | ----         | ----             |

### SAR result with Body TSL at 5600 MHz

|   |                    |                                 |
|---|--------------------|---------------------------------|
| <b>SAR averaged over 1 cm<sup>3</sup> (1 g) of Body TSL</b>   | Condition          |                                 |
| SAR measured  | 100 mW input power | 7.75 W/kg                       |
| SAR for nominal Body TSL parameters                           | normalized to 1W   | <b>77.4 W/kg ± 24.4 % (k=2)</b> |
| <b>SAR averaged over 10 cm<sup>3</sup> (10 g) of Body TSL</b> | Condition          |                                 |
| SAR measured  | 100 mW input power | 2.18 W/kg                       |
| SAR for nominal Body TSL parameters                           | normalized to 1W   | <b>21.8 W/kg ± 24.2 % (k=2)</b> |



Add: No.51 Xueyuan Road, Haidian District, Beijing, 100191, China  
Tel: +86-10-62304633-2512 Fax: +86-10-62304633-2504  
E-mail: cttl@chinattl.com http://www.chinattl.cn

### Body TSL parameters at 5750 MHz

The following parameters and calculations were applied.

|   | Temperature     | Permittivity | Conductivity     |
|---|-----------------|--------------|------------------|
| Nominal Body TSL parameters             | 22.0 °C         | 48.3         | 5.94 mho/m       |
| Measured Body TSL parameters            | (22.0 ± 0.2) °C | 48.0 ± 6 %   | 5.92 mho/m ± 6 % |
| Body TSL temperature change during test | <1.0 °C         | ----         | ----             |

### SAR result with Body TSL at 5750 MHz

|   |                    |                                 |
|---|--------------------|---------------------------------|
| <b>SAR averaged over 1 cm<sup>3</sup> (1 g) of Body TSL</b>   | Condition          |                                 |
| SAR measured  | 100 mW input power | 7.34 W/kg                       |
| SAR for nominal Body TSL parameters                           | normalized to 1W   | <b>73.3 W/kg ± 24.4 % (k=2)</b> |
| <b>SAR averaged over 10 cm<sup>3</sup> (10 g) of Body TSL</b> | Condition          |                                 |
| SAR measured  | 100 mW input power | 2.05 W/kg                       |
| SAR for nominal Body TSL parameters                           | normalized to 1W   | <b>20.5 W/kg ± 24.2 % (k=2)</b> |



Add: No.51 Xueyuan Road, Haidian District, Beijing, 100191, China  
Tel: +86-10-62304633-2512 Fax: +86-10-62304633-2504  
E-mail: cttl@chinattl.com http://www.chinattl.cn

### Appendix (Additional assessments outside the scope of CNAS L0570)

#### Antenna Parameters with Head TSL at 5250 MHz

|                                      |                                |
|--------------------------------------|--------------------------------|
| Impedance, transformed to feed point | 49.1 $\Omega$ - 2.47j $\Omega$ |
| Return Loss                          | - 31.5dB                       |

#### Antenna Parameters with Head TSL at 5600 MHz

|                                      |                                |
|--------------------------------------|--------------------------------|
| Impedance, transformed to feed point | 53.7 $\Omega$ + 2.04j $\Omega$ |
| Return Loss                          | - 27.7dB                       |

#### Antenna Parameters with Head TSL at 5750 MHz

|                                      |                                |
|--------------------------------------|--------------------------------|
| Impedance, transformed to feed point | 52.5 $\Omega$ + 5.75j $\Omega$ |
| Return Loss                          | - 24.3dB                       |

#### Antenna Parameters with Body TSL at 5250 MHz

|                                      |                                |
|--------------------------------------|--------------------------------|
| Impedance, transformed to feed point | 48.6 $\Omega$ - 1.32j $\Omega$ |
| Return Loss                          | - 34.2dB                       |

#### Antenna Parameters with Body TSL at 5600 MHz

|                                      |                                |
|--------------------------------------|--------------------------------|
| Impedance, transformed to feed point | 54.6 $\Omega$ + 3.49j $\Omega$ |
| Return Loss                          | - 25.1dB                       |

#### Antenna Parameters with Body TSL at 5750 MHz

|                                      |                                |
|--------------------------------------|--------------------------------|
| Impedance, transformed to feed point | 53.5 $\Omega$ + 8.23j $\Omega$ |
| Return Loss                          | - 21.3dB                       |



In Collaboration with  
**s p e a g**  
**CALIBRATION LABORATORY**

Add: No.51 Xueyuan Road, Haidian District, Beijing, 100191, China  
Tel: +86-10-62304633-2512 Fax: +86-10-62304633-2504  
E-mail: cttl@chinattl.com http://www.chinattl.cn

### General Antenna Parameters and Design

|                                  |          |
|----------------------------------|----------|
| Electrical Delay (one direction) | 1.056 ns |
|----------------------------------|----------|

After long term use with 100W radiated power, only a slight warming of the dipole near the feedpoint can be measured.

The dipole is made of standard semirigid coaxial cable. The center conductor of the feeding line is directly connected to the second arm of the dipole. The antenna is therefore short-circuited for DC-signals. On some of the dipoles, small end caps are added to the dipole arms in order to improve matching when loaded according to the position as explained in the "Measurement Conditions" paragraph. The SAR data are not affected by this change. The overall dipole length is still according to the Standard.

No excessive force must be applied to the dipole arms, because they might bend or the soldered connections near the feedpoint may be damaged.

### Additional EUT Data

|                 |       |
|-----------------|-------|
| Manufactured by | SPEAG |
|-----------------|-------|





Add: No.51 Xueyuan Road, Haidian District, Beijing, 100191, China  
Tel: +86-10-62304633-2512 Fax: +86-10-62304633-2504  
E-mail: cttl@chinattl.com http://www.chinattl.cn

## DASY5 Validation Report for Head TSL

Date: 12.20.2019

Test Laboratory: CTTL, Beijing, China

**DUT: Dipole 5GHz; Type: D5GHzV2; Serial: D5GHzV2 - SN: 1203**

Communication System: CW; Frequency: 5250 MHz, Frequency: 5600 MHz,  
Frequency: 5750 MHz,

Medium parameters used:  $f = 5250$  MHz;  $\sigma = 4.688$  S/m;  $\epsilon_r = 36.3$ ;  $\rho = 1000$  kg/m<sup>3</sup>,

Medium parameters used:  $f = 5600$  MHz;  $\sigma = 5.066$  S/m;  $\epsilon_r = 35.69$ ;  $\rho = 1000$

kg/m<sup>3</sup>, Medium parameters used:  $f = 5750$  MHz;  $\sigma = 5.23$  S/m;  $\epsilon_r = 35.47$ ;  $\rho = 1000$

kg/m<sup>3</sup>,  
Phantom section: Center Section

### DASY5 Configuration:

- Probe: EX3DV4 - SN3617; ConvF(5.39, 5.39, 5.39) @ 5250 MHz; ConvF(5.06, 5.06, 5.06) @ 5600 MHz; ConvF(5.07, 5.07, 5.07) @ 5750 MHz; Calibrated: 1/31/2019
- Sensor-Surface: 1.4mm (Mechanical Surface Detection)
- Electronics: DAE4 Sn1555; Calibrated: 8/22/2019
- Phantom: MFP\_V5.1C ; Type: QD 000 P51CA; Serial: 1062
- Measurement SW: DASY52, Version 52.10 (3); SEMCAD X Version 14.6.13 (7474)

### Dipole Calibration /Pin=100mW, d=10mm, f=5250 MHz/Zoom Scan,

**dist=1.4mm (8x8x7)/Cube 0:** Measurement grid: dx=4mm, dy=4mm, dz=1.4mm

Reference Value = 64.76 V/m; Power Drift = 0.03 dB

Peak SAR (extrapolated) = 31.5 W/kg

**SAR(1 g) = 7.53 W/kg; SAR(10 g) = 2.14 W/kg**

Smallest distance from peaks to all points 3 dB below = 6.9 mm

Ratio of SAR at M2 to SAR at M1 = 63%

Maximum value of SAR (measured) = 17.5 W/kg

### Dipole Calibration /Pin=100mW, d=10mm, f=5600 MHz/Zoom Scan,

**dist=1.4mm (8x8x7)/Cube 0:** Measurement grid: dx=4mm, dy=4mm, dz=1.4mm

Reference Value = 62.25 V/m; Power Drift = 0.08 dB

Peak SAR (extrapolated) = 35.4 W/kg

**SAR(1 g) = 7.99 W/kg; SAR(10 g) = 2.28 W/kg**

Smallest distance from peaks to all points 3 dB below = 7.4 mm

Ratio of SAR at M2 to SAR at M1 = 63.1%

Maximum value of SAR (measured) = 19.4 W/kg



Add: No.51 Xueyuan Road, Haidian District, Beijing, 100191, China  
Tel: +86-10-62304633-2512 Fax: +86-10-62304633-2504  
E-mail: cttl@chinattl.com http://www.chinattl.cn

**Dipole Calibration /Pin=100mW, d=10mm, f=5750 MHz/Zoom Scan,**  
**dist=1.4mm (8x8x7)/Cube 0: Measurement grid: dx=4mm, dy=4mm, dz=1.4mm**  
Reference Value = 67.12 V/m; Power Drift = 0.01 dB  
Peak SAR (extrapolated) = 36.4 W/kg  
**SAR(1 g) = 7.78 W/kg; SAR(10 g) = 2.21 W/kg**  
Smallest distance from peaks to all points 3 dB below = 7.5 mm  
Ratio of SAR at M2 to SAR at M1 = 61.2%  
Maximum value of SAR (measured) = 19.7 W/kg

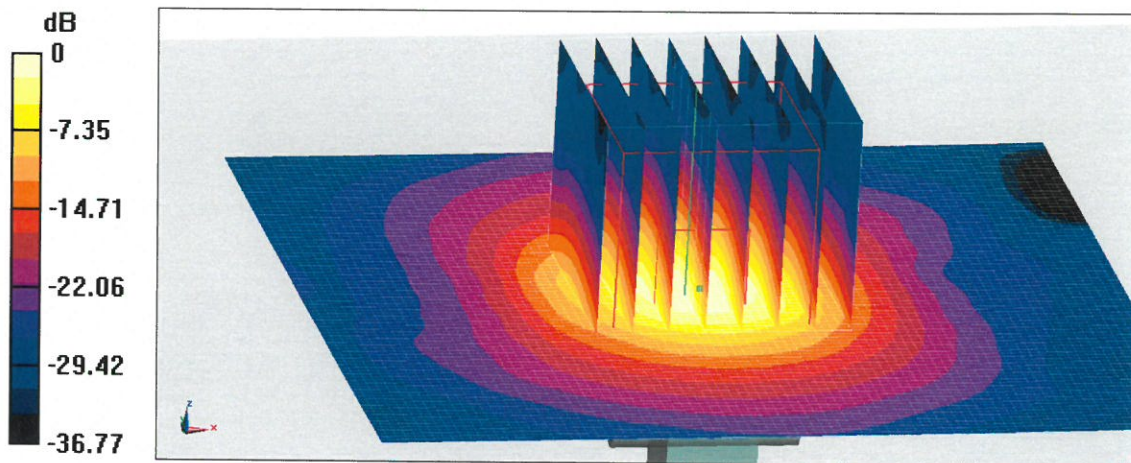

0 dB = 19.7 W/kg = 12.94 dBW/kg



Add: No.51 Xueyuan Road, Haidian District, Beijing, 100191, China  
Tel: +86-10-62304633-2512 Fax: +86-10-62304633-2504  
E-mail: cttl@chinattl.com http://www.chinattl.cn

### Impedance Measurement Plot for Head TSL

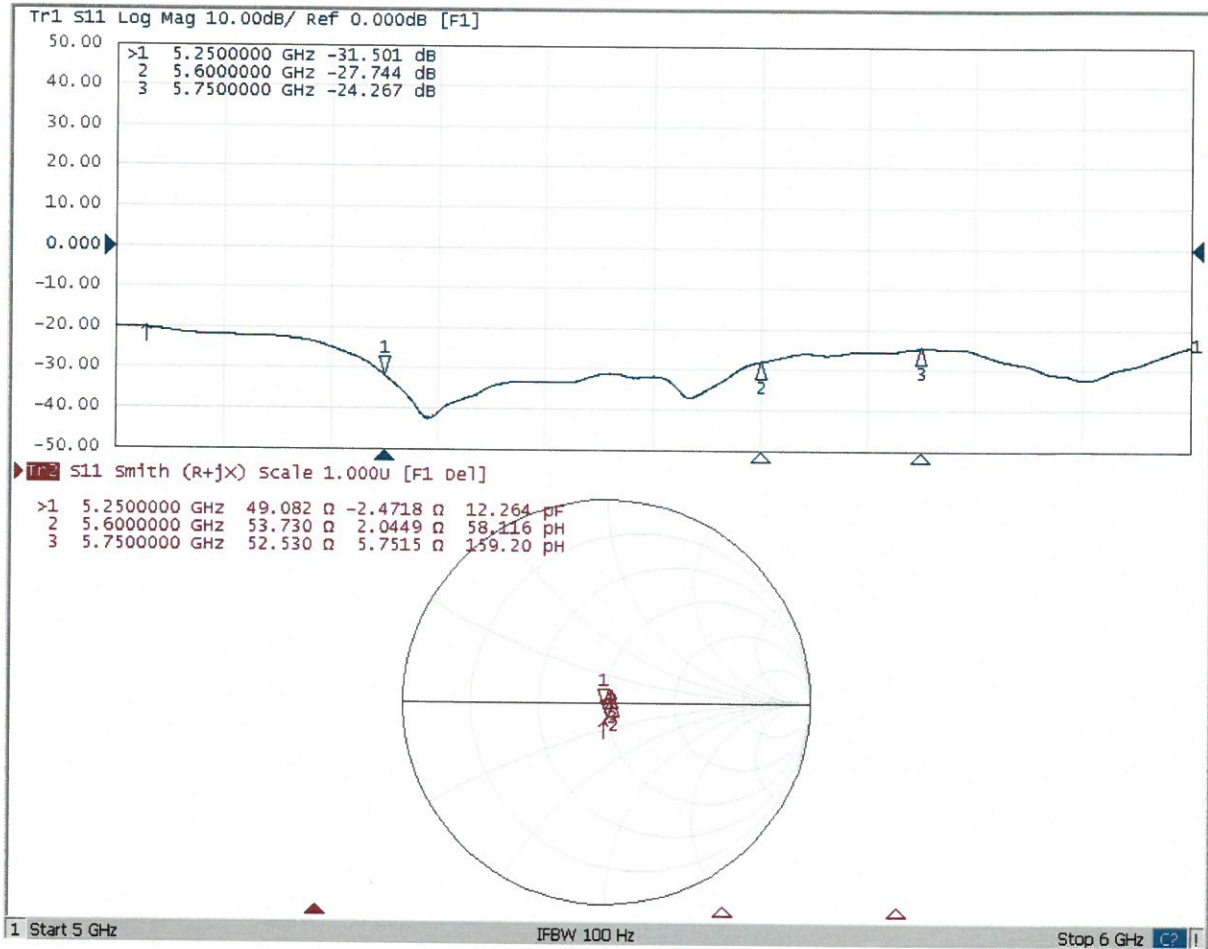





Add: No.51 Xueyuan Road, Haidian District, Beijing, 100191, China  
Tel: +86-10-62304633-2512 Fax: +86-10-62304633-2504  
E-mail: cttl@chinattl.com http://www.chinattl.cn

## DASY5 Validation Report for Body TSL

Date: 12.19.2019

Test Laboratory: CTTL, Beijing, China

**DUT: Dipole 5GHz; Type: D5GHzV2; Serial: D5GHzV2 - SN: 1203**

Communication System: CW; Frequency: 5250 MHz, Frequency: 5600 MHz,  
Frequency: 5750 MHz,

Medium parameters used:  $f = 5250$  MHz;  $\sigma = 5.232$  S/m;  $\epsilon_r = 49.05$ ;  $\rho = 1000$  kg/m<sup>3</sup>,  
Medium parameters used:  $f = 5600$  MHz;  $\sigma = 5.697$  S/m;  $\epsilon_r = 48.37$ ;  $\rho = 1000$  kg/m<sup>3</sup>,  
Medium parameters used:  $f = 5750$  MHz;  $\sigma = 5.923$  S/m;  $\epsilon_r = 48.04$ ;  $\rho = 1000$  kg/m<sup>3</sup>,

Phantom section: Right Section

### DASY5 Configuration:

- Probe: EX3DV4 - SN3617; ConvF(4.76, 4.76, 4.76) @ 5250 MHz; ConvF(4.23, 4.23, 4.23) @ 5600 MHz; ConvF(4.36, 4.36, 4.36) @ 5750 MHz; Calibrated: 1/31/2019
- Sensor-Surface: 1.4mm (Mechanical Surface Detection)
- Electronics: DAE4 Sn1555; Calibrated: 8/22/2019
- Phantom: MFP\_V5.1C ; Type: QD 000 P51CA; Serial: 1062
- Measurement SW: DASY52, Version 52.10 (3); SEMCAD X Version 14.6.13 (7474)

### Dipole Calibration /Pin=100mW, d=10mm, f=5250 MHz/Zoom Scan,

**dist=1.4mm (8x8x7)/Cube 0:** Measurement grid: dx=4mm, dy=4mm, dz=1.4mm

Reference Value = 64.58 V/m; Power Drift = 0.00 dB

Peak SAR (extrapolated) = 28.6 W/kg

**SAR(1 g) = 7.29 W/kg; SAR(10 g) = 2.05 W/kg**

Smallest distance from peaks to all points 3 dB below = 6.8 mm

Ratio of SAR at M2 to SAR at M1 = 66.7%

Maximum value of SAR (measured) = 17.1 W/kg

### Dipole Calibration /Pin=100mW, d=10mm, f=5600 MHz/Zoom Scan,

**dist=1.4mm (8x8x7)/Cube 0:** Measurement grid: dx=4mm, dy=4mm, dz=1.4mm

Reference Value = 64.63 V/m; Power Drift = -0.02 dB

Peak SAR (extrapolated) = 34.3 W/kg

**SAR(1 g) = 7.75 W/kg; SAR(10 g) = 2.18 W/kg**

Smallest distance from peaks to all points 3 dB below = 7.2 mm

Ratio of SAR at M2 to SAR at M1 = 63.6%

Maximum value of SAR (measured) = 19.1 W/kg