

System Check_B2450_0404

DUT: Dipole 2450 MHz D2450V2;SN:919;

Communication System: UID 0, CW (0); Frequency: 2450 MHz; Duty Cycle: 1:1
Medium parameters used (interpolated): $f = 2450$ MHz; $\sigma = 2.005$ S/m; $\epsilon_r = 51.488$; $\rho = 1000$ kg/m³
Ambient Temperature : 23.3 °C; Liquid Temperature : 22.4 °C

DASY Configuration:

- Probe: EX3DV4 - SN7396; ConvF(7.7, 7.7, 7.7) @ 2450 MHz; Calibrated: 2018-05-29
- Sensor-Surface: 4mm (Mechanical Surface Detection), $z = 1.0, 31.0$
- Electronics: DAE4 Sn1390; Calibrated: 2018-05-11
- Phantom: ELI v5.0; Type: QDOVA002AA; Serial: TP:1222
- DASY52 52.10.2(1495); SEMCAD X 14.6.12(7450)

Area Scan (7x7x1): Interpolated grid: $dx=12$ mm, $dy=12$ mm
Maximum value of SAR (interpolated) = 15.6 W/kg

Zoom Scan (7x7x7)/Cube 0: Measurement grid: $dx=5$ mm, $dy=5$ mm, $dz=5$ mm
Reference Value = 99.42 V/m; Power Drift = 0.01 dB
Peak SAR (extrapolated) = 24.8 W/kg
SAR(1 g) = 12.4 W/kg; SAR(10 g) = 5.77 W/kg
Maximum value of SAR (measured) = 14.2 W/kg

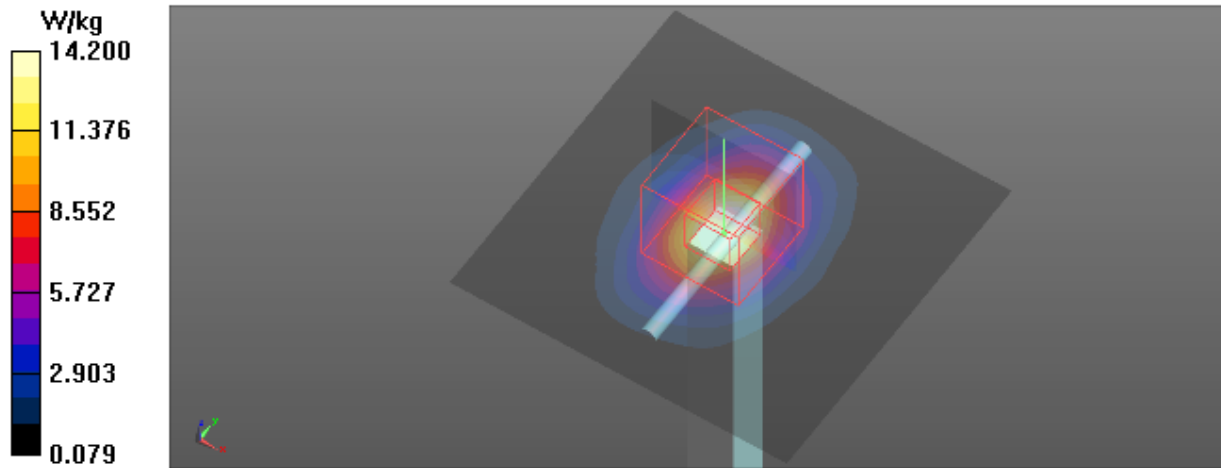

System Check_B5200_0403

DUT: Dipole D5GHzV2;SN;1160;

Communication System: UID 0, CW (0); Frequency: 5200 MHz; Duty Cycle: 1:1
Medium parameters used: $f = 5200$ MHz; $\sigma = 5.266$ S/m; $\epsilon_r = 49.215$; $\rho = 1000$ kg/m³
Ambient Temperature : 23.4 °C; Liquid Temperature : 22.2 °C

DASY Configuration:

- Probe: EX3DV4 - SN7396; ConvF(5.3, 5.3, 5.3) @ 5200 MHz; Calibrated: 2018-05-29
- Sensor-Surface: 2mm (Mechanical Surface Detection), $z = 1.0, 23.0$
- Electronics: DAE4 Sn1390; Calibrated: 2018-05-11
- Phantom: ELI v5.0; Type: QDOVA002AA; Serial: TP:1222
- DASY52 52.10.2(1495); SEMCAD X 14.6.12(7450)

Area Scan (6x5x1): Interpolated grid: $dx=10$ mm, $dy=10$ mm
Maximum value of SAR (interpolated) = 14.2 W/kg

Zoom Scan (7x7x12)/Cube 0: Measurement grid: $dx=4$ mm, $dy=4$ mm, $dz=2$ mm
Reference Value = 37.95 V/m; Power Drift = -0.01 dB
Peak SAR (extrapolated) = 28.8 W/kg
SAR(1 g) = 6.76 W/kg; SAR(10 g) = 1.91 W/kg
Maximum value of SAR (measured) = 14.1 W/kg

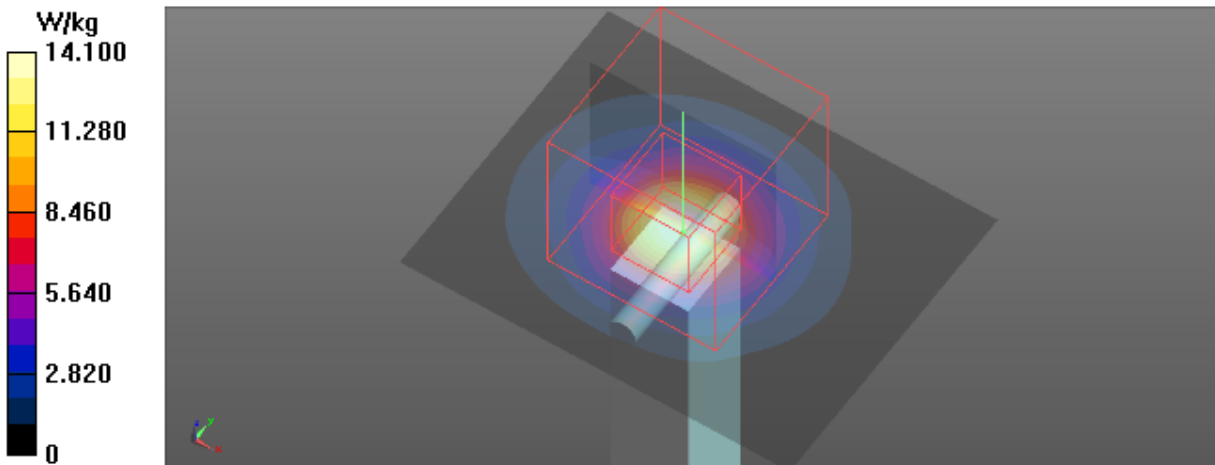

System Check_B5200_0425

DUT: Dipole D5GHzV2;SN;1160;

Communication System: UID 0, CW (0); Frequency: 5200 MHz; Duty Cycle: 1:1
Medium parameters used: $f = 5200$ MHz; $\sigma = 5.372$ S/m; $\epsilon_r = 47.807$; $\rho = 1000$ kg/m³
Ambient Temperature : 23.6 °C; Liquid Temperature : 22.3 °C

DASY Configuration:

- Probe: EX3DV4 - SN7396; ConvF(5.3, 5.3, 5.3) @ 5200 MHz; Calibrated: 2018-05-29
- Sensor-Surface: 2mm (Mechanical Surface Detection), $z = 1.0, 23.0$
- Electronics: DAE4 Sn1390; Calibrated: 2018-05-11
- Phantom: SAM Right; Type: Twin SAM; Serial: 1896
- DASY52 52.10.2(1495); SEMCAD X 14.6.12(7450)

Area Scan (6x5x1): Interpolated grid: $dx=10$ mm, $dy=10$ mm
Maximum value of SAR (interpolated) = 14.4 W/kg

Zoom Scan (7x7x12)/Cube 0: Measurement grid: $dx=4$ mm, $dy=4$ mm, $dz=2$ mm
Reference Value = 37.95 V/m; Power Drift = -0.01 dB
Peak SAR (extrapolated) = 29.4 W/kg
SAR(1 g) = 6.89 W/kg; SAR(10 g) = 1.95 W/kg
Maximum value of SAR (measured) = 14.4 W/kg

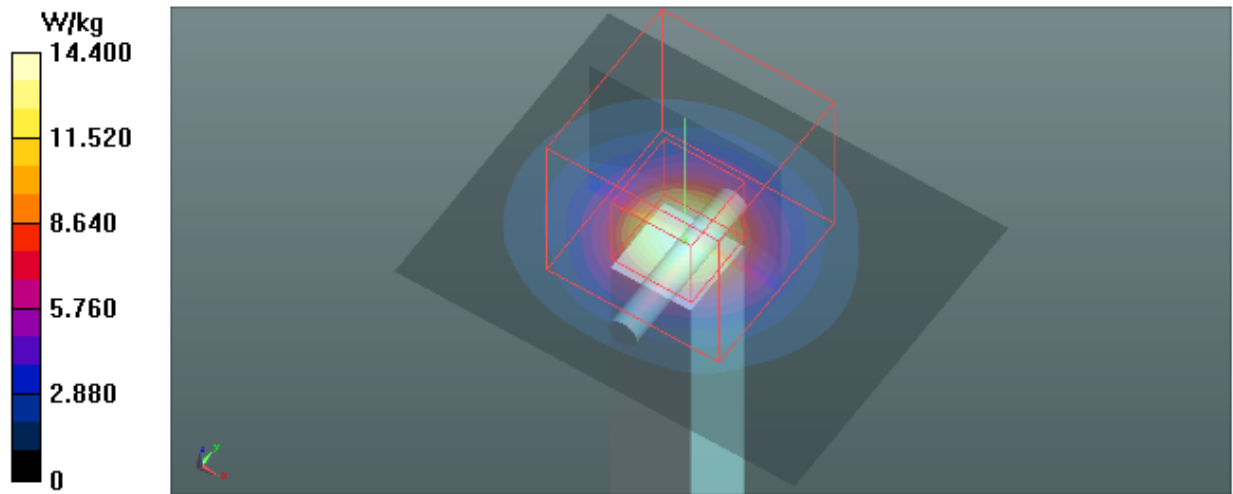

System Check_B5300_0403

DUT: Dipole D5GHzV2;SN;1160;

Communication System: UID 0, CW (0); Frequency: 5300 MHz; Duty Cycle: 1:1
Medium parameters used: $f = 5300$ MHz; $\sigma = 5.403$ S/m; $\epsilon_r = 49.047$; $\rho = 1000$ kg/m³
Ambient Temperature : 23.4 °C; Liquid Temperature : 22.2 °C

DASY Configuration:

- Probe: EX3DV4 - SN7396; ConvF(5.05, 5.05, 5.05) @ 5300 MHz; Calibrated: 2018-05-29
- Sensor-Surface: 2mm (Mechanical Surface Detection), $z = 1.0, 23.0$
- Electronics: DAE4 Sn1390; Calibrated: 2018-05-11
- Phantom: ELI v5.0; Type: QDOVA002AA; Serial: TP:1222
- DASY52 52.10.2(1495); SEMCAD X 14.6.12(7450)

Area Scan (5x5x1): Interpolated grid: $dx=10$ mm, $dy=10$ mm
Maximum value of SAR (interpolated) = 14.1 W/kg

Zoom Scan (7x7x12)/Cube 0: Measurement grid: $dx=4$ mm, $dy=4$ mm, $dz=2$ mm
Reference Value = 36.40 V/m; Power Drift = -0.05 dB
Peak SAR (extrapolated) = 30.3 W/kg
SAR(1 g) = 6.88 W/kg; SAR(10 g) = 1.95 W/kg
Maximum value of SAR (measured) = 14.5 W/kg

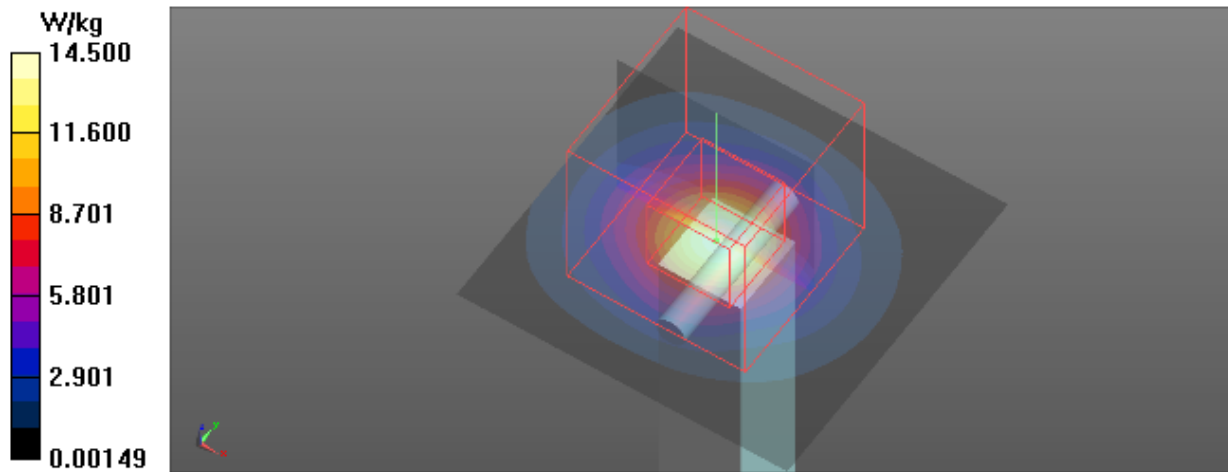

System Check_B5500_0403

DUT: Dipole D5GHzV2;SN;1160;

Communication System: UID 0, CW (0); Frequency: 5500 MHz; Duty Cycle: 1:1
Medium parameters used: $f = 5500$ MHz; $\sigma = 5.712$ S/m; $\epsilon_r = 48.722$; $\rho = 1000$ kg/m³
Ambient Temperature : 23.4 °C; Liquid Temperature : 22.2 °C

DASY Configuration:

- Probe: EX3DV4 - SN7396; ConvF(4.38, 4.38, 4.38) @ 5500 MHz; Calibrated: 2018-05-29
- Sensor-Surface: 2mm (Mechanical Surface Detection), $z = 1.0, 23.0$
- Electronics: DAE4 Sn1390; Calibrated: 2018-05-11
- Phantom: ELI v5.0; Type: QDOVA002AA; Serial: TP:1222
- DASY52 52.10.2(1495); SEMCAD X 14.6.12(7450)

Area Scan (5x5x1): Interpolated grid: $dx=10$ mm, $dy=10$ mm
Maximum value of SAR (interpolated) = 15.1 W/kg

Zoom Scan (7x7x12)/Cube 0: Measurement grid: $dx=4$ mm, $dy=4$ mm, $dz=2$ mm
Reference Value = 36.02 V/m; Power Drift = 0.01 dB
Peak SAR (extrapolated) = 32.9 W/kg
SAR(1 g) = 7.28 W/kg; SAR(10 g) = 2.05 W/kg
Maximum value of SAR (measured) = 15.4 W/kg

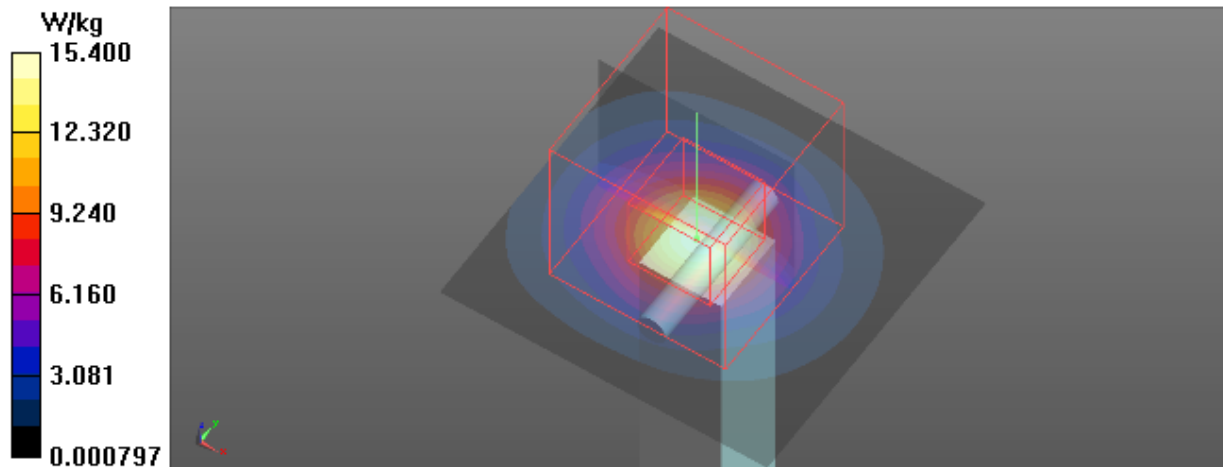

System Check_B5600_0403

DUT: Dipole D5GHzV2;SN;1160;

Communication System: UID 0, CW (0); Frequency: 5600 MHz; Duty Cycle: 1:1
Medium parameters used: $f = 5600$ MHz; $\sigma = 5.869$ S/m; $\epsilon_r = 48.465$; $\rho = 1000$ kg/m³
Ambient Temperature : 23.4 °C; Liquid Temperature : 22.2 °C

DASY Configuration:

- Probe: EX3DV4 - SN7396; ConvF(4.38, 4.38, 4.38) @ 5600 MHz; Calibrated: 2018-05-29
- Sensor-Surface: 2mm (Mechanical Surface Detection), $z = 1.0, 23.0$
- Electronics: DAE4 Sn1390; Calibrated: 2018-05-11
- Phantom: ELI v5.0; Type: QDOVA002AA; Serial: TP:1222
- DASY52 52.10.2(1495); SEMCAD X 14.6.12(7450)

Area Scan (5x5x1): Interpolated grid: $dx=10$ mm, $dy=10$ mm
Maximum value of SAR (interpolated) = 16.8 W/kg

Zoom Scan (7x7x12)/Cube 0: Measurement grid: $dx=4$ mm, $dy=4$ mm, $dz=2$ mm
Reference Value = 37.09 V/m; Power Drift = -0.06 dB
Peak SAR (extrapolated) = 37.4 W/kg
SAR(1 g) = 8 W/kg; SAR(10 g) = 2.21 W/kg
Maximum value of SAR (measured) = 17.2 W/kg

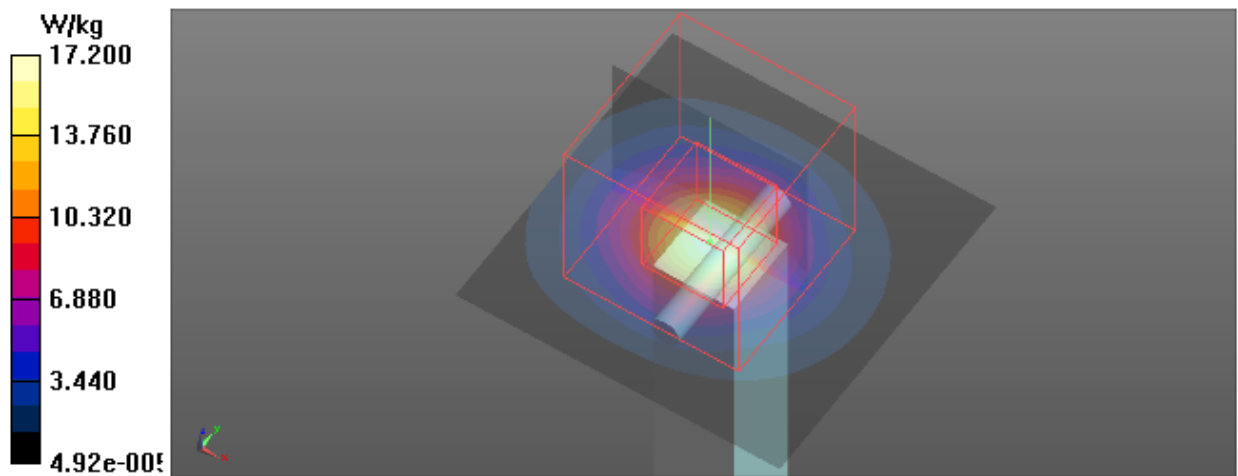

System Check_B5800_0404

DUT: Dipole D5GHzV2;SN;1160;

Communication System: UID 0, CW (0); Frequency: 5800 MHz; Duty Cycle: 1:1
Medium parameters used: $f = 5800$ MHz; $\sigma = 6.127$ S/m; $\epsilon_r = 47.966$; $\rho = 1000$ kg/m³
Ambient Temperature : 23.1 °C; Liquid Temperature : 22.3 °C

DASY Configuration:

- Probe: EX3DV4 - SN7396; ConvF(4.5, 4.5, 4.5) @ 5800 MHz; Calibrated: 2018-05-29
- Sensor-Surface: 2mm (Mechanical Surface Detection), $z = 1.0, 23.0$
- Electronics: DAE4 Sn1390; Calibrated: 2018-05-11
- Phantom: ELI v5.0; Type: QDOVA002AA; Serial: TP:1222
- DASY52 52.10.2(1495); SEMCAD X 14.6.12(7450)

Area Scan (6x6x1): Interpolated grid: $dx=10$ mm, $dy=10$ mm
Maximum value of SAR (interpolated) = 20.1 W/kg

Zoom Scan (7x7x12)/Cube 0: Measurement grid: $dx=4$ mm, $dy=4$ mm, $dz=2$ mm
Reference Value = 35.35 V/m; Power Drift = -0.03 dB
Peak SAR (extrapolated) = 34.9 W/kg
SAR(1 g) = 7.41 W/kg; SAR(10 g) = 2.1 W/kg
Maximum value of SAR (measured) = 15.9 W/kg

