

RADIO TEST REPORT

FCC 47 CFR PART 15 SUBPART E

CLASS II PERMISSIVE CHANGE

Test Standard	FCC Part 15.407
FCC ID	TX2-RTL8821AU
Product name	802.11a/b/g/n/ac RTL8821AU Combo module
Brand Name	Realtek
Model	RTL8821AU
Test Result	Pass

The test Result was tested by Compliance Certification Services Inc. The test data, data evaluation, test procedures, and equipment configurations shown in this report were given in ANSI C63.10: 2013 and compliance standards.

The test results of this report relate only to the tested sample (EUT) identified in this report.

The test Report of full or partial shall not copy. Without written approval of Compliance Certification Services Inc. (Wugu Laboratory)



Approved by:

Handwritten signature of Sam Chuang in black ink.

Sam Chuang
Manager

Reviewed by:

Handwritten signature of Kevin Kuo in black ink.

Kevin Kuo
Engineer

Revision History

Rev.	Issue Date	Revisions	Effect Page	Revised By
00	December 4, 2017	Initial Issue	ALL	Allison Chen
01	December 7, 2017	1. Modify section 1.6.	P.7	Allison Chen

Table of contents

1. GENERAL INFORMATION	4
1.1 EUT INFORMATION	4
1.2 EUT CHANNEL INFORMATION	5
1.3 ANTENNA INFORMATION	6
1.4 MEASUREMENT UNCERTAINTY.....	7
1.5 FACILITIES AND TEST LOCATION	8
1.6 INSTRUMENT CALIBRATION	8
1.7 SUPPORT AND EUT ACCESSORIES EQUIPMENT	9
1.8 TEST METHODOLOGY AND APPLIED STANDARDS	9
2. TEST SUMMERY	10
3. DESCRIPTION OF TEST MODES	11
3.1 THE WORST MODE OF OPERATING CONDITION	11
3.2 THE WORST MODE OF MEASUREMENT	12
3.3 EUT DUTY CYCLE.....	13
4. TEST RESULT	14
4.1 AC POWER LINE CONDUCTED EMISSION	14
4.2 OUTPUT POWER MEASUREMENT	17
4.3 RADIATION BANDEDGE AND SPURIOUS EMISSION	23
APPENDIX 1 - PHOTOGRAPHS OF EUT	

1. GENERAL INFORMATION

1.1 EUT INFORMATION

Applicant	Realtek Semiconductor Corp. No. 2, Innovation Road II, Hsinchu Science Park, Hsinchu, 300 Taiwan																																																													
Applicant Adress	Realtek Semiconductor Corp. No. 2, Innovation Road II, Hsinchu Science Park, Hsinchu, 300 Taiwan																																																													
Equipment	802.11a/b/g/n/ac RTL8821AU Combo module																																																													
Model No.	RTL8821AU																																																													
Model Discrepancy	N/A																																																													
Trade Name	Realtek																																																													
Received Date	October 12, 2017																																																													
Date of Test	November 30 ~ December 2, 2017																																																													
Output Power	<table border="1"> <thead> <tr> <th>Band</th> <th>Mode</th> <th>Frequency Range (MHz)</th> <th>Output Power (dBm)</th> <th>Output Power (w)</th> </tr> </thead> <tbody> <tr> <td rowspan="3">U-NII-1</td> <td>IEEE 802.11a</td> <td>5180 ~ 5240</td> <td>11.87</td> <td>0.01538</td> </tr> <tr> <td>IEEE 802.11n HT 20 MHz</td> <td>5180 ~ 5240</td> <td>11.77</td> <td>0.01503</td> </tr> <tr> <td>IEEE 802.11n HT 40 MHz</td> <td>5190 ~ 5230</td> <td>11.57</td> <td>0.01435</td> </tr> <tr> <td rowspan="3">U-NII-2a</td> <td>IEEE 802.11a</td> <td>5260 ~ 5320</td> <td>11.84</td> <td>0.01528</td> </tr> <tr> <td>IEEE 802.11n HT 20 MHz</td> <td>5260 ~ 5320</td> <td>11.87</td> <td>0.01538</td> </tr> <tr> <td>IEEE 802.11n HT 40 MHz</td> <td>5270 ~ 5310</td> <td>12.36</td> <td>0.01722</td> </tr> <tr> <td rowspan="3">U-NII-2c</td> <td>IEEE 802.11a</td> <td>5500 ~ 5725</td> <td>11.67</td> <td>0.01469</td> </tr> <tr> <td>IEEE 802.11n HT 20 MHz</td> <td>5500 ~ 5725</td> <td>11.89</td> <td>0.01545</td> </tr> <tr> <td>IEEE 802.11n HT 40 MHz</td> <td>5510 ~ 5670</td> <td>12.49</td> <td>0.01774</td> </tr> <tr> <td rowspan="3">U-NII-3</td> <td>IEEE 802.11a</td> <td>5745 ~ 5825</td> <td>11.87</td> <td>0.01538</td> </tr> <tr> <td>IEEE 802.11n HT 20 MHz</td> <td>5745 ~ 5825</td> <td>11.87</td> <td>0.01538</td> </tr> <tr> <td>IEEE 802.11n HT 40 MHz</td> <td>5755 ~ 5795</td> <td>12.82</td> <td>0.01914</td> </tr> </tbody> </table>					Band	Mode	Frequency Range (MHz)	Output Power (dBm)	Output Power (w)	U-NII-1	IEEE 802.11a	5180 ~ 5240	11.87	0.01538	IEEE 802.11n HT 20 MHz	5180 ~ 5240	11.77	0.01503	IEEE 802.11n HT 40 MHz	5190 ~ 5230	11.57	0.01435	U-NII-2a	IEEE 802.11a	5260 ~ 5320	11.84	0.01528	IEEE 802.11n HT 20 MHz	5260 ~ 5320	11.87	0.01538	IEEE 802.11n HT 40 MHz	5270 ~ 5310	12.36	0.01722	U-NII-2c	IEEE 802.11a	5500 ~ 5725	11.67	0.01469	IEEE 802.11n HT 20 MHz	5500 ~ 5725	11.89	0.01545	IEEE 802.11n HT 40 MHz	5510 ~ 5670	12.49	0.01774	U-NII-3	IEEE 802.11a	5745 ~ 5825	11.87	0.01538	IEEE 802.11n HT 20 MHz	5745 ~ 5825	11.87	0.01538	IEEE 802.11n HT 40 MHz	5755 ~ 5795	12.82	0.01914
Band	Mode	Frequency Range (MHz)	Output Power (dBm)	Output Power (w)																																																										
U-NII-1	IEEE 802.11a	5180 ~ 5240	11.87	0.01538																																																										
	IEEE 802.11n HT 20 MHz	5180 ~ 5240	11.77	0.01503																																																										
	IEEE 802.11n HT 40 MHz	5190 ~ 5230	11.57	0.01435																																																										
U-NII-2a	IEEE 802.11a	5260 ~ 5320	11.84	0.01528																																																										
	IEEE 802.11n HT 20 MHz	5260 ~ 5320	11.87	0.01538																																																										
	IEEE 802.11n HT 40 MHz	5270 ~ 5310	12.36	0.01722																																																										
U-NII-2c	IEEE 802.11a	5500 ~ 5725	11.67	0.01469																																																										
	IEEE 802.11n HT 20 MHz	5500 ~ 5725	11.89	0.01545																																																										
	IEEE 802.11n HT 40 MHz	5510 ~ 5670	12.49	0.01774																																																										
U-NII-3	IEEE 802.11a	5745 ~ 5825	11.87	0.01538																																																										
	IEEE 802.11n HT 20 MHz	5745 ~ 5825	11.87	0.01538																																																										
	IEEE 802.11n HT 40 MHz	5755 ~ 5795	12.82	0.01914																																																										
Power Operation	<p>1. Power from host device. (DC 3.8V) 2. Power from Li-ion Polymer Battery. Model: PR-464059G (1ICP5/40/59) Nominal Voltage: 3.8V Rated Capacity: 1630mAh / 6.2Wh Limited Charge voltage: 4.35V</p>																																																													
Class II Permissive Change	Applicants add a new appearance of EUT and change the circuit and layout, but the antenna type and module are identical with original.																																																													

1.2 EUT CHANNEL INFORMATION

Frequency Range	UNII-1	
	IEEE 802.11a	5180 ~ 5240 MHz
	IEEE 802.11n HT 20 MHz	5180 ~ 5240 MHz
	IEEE 802.11n HT 40 MHz	5190 ~ 5230 MHz
	UNII-2a	
	IEEE 802.11a	5260 ~ 5320 MHz
	IEEE 802.11n HT 20 MHz	5260 ~ 5320 MHz
	IEEE 802.11n HT 40 MHz	5270 ~ 5310 MHz
	UNII-2c	
	IEEE 802.11a	5500 ~ 5700 MHz
	IEEE 802.11n HT 20 MHz	5500 ~ 5700 MHz
	IEEE 802.11n HT 40 MHz	5510 ~ 5670 MHz
	UNII-3	
	IEEE 802.11a	5745 ~ 5825 MHz
IEEE 802.11n HT 20 MHz	5745 ~ 5825 MHz	
IEEE 802.11n HT 40 MHz	5755 ~ 5795 MHz	
Modulation Type	<ol style="list-style-type: none"> 1. IEEE 802.11a mode: OFDM 2. IEEE 802.11n HT 20 MHz mode: OFDM 3. IEEE 802.11n HT 40 MHz mode: OFDM 	

Remark:

Refer as ANSI 63.10:2013 clause 5.6.1 Table 4 for test channels

Number of frequencies to be tested		
Frequency range in which device operates	Number of frequencies	Location in frequency range of operation
<input type="checkbox"/> 1 MHz or less	1	Middle
<input type="checkbox"/> 1 MHz to 10 MHz	2	1 near top and 1 near bottom
<input checked="" type="checkbox"/> More than 10 MHz	3	1 near top, 1 near middle, and 1 near bottom

1.3 ANTENNA INFORMATION

Antenna Type	<input checked="" type="checkbox"/> PIFA <input type="checkbox"/> PCB for <input type="checkbox"/> Dipole <input type="checkbox"/> Printed <input type="checkbox"/> Coils
Antenna Gain	1.5dBi

1.4 MEASUREMENT UNCERTAINTY

PARAMETER	UNCERTAINTY
Semi Anechoic Chamber (966 Chamber_B) / Radiated Emission, 30 to 1000 MHz	+/- 3.97
Semi Anechoic Chamber (966 Chamber_B) / Radiated Emission, 1 to 18GHz	+/- 3.58
Semi Anechoic Chamber (966 Chamber_B) / Radiated Emission, 18 to 26 GHz	+/- 3.59
Semi Anechoic Chamber (966 Chamber_B) / Radiated Emission, 26 to 40 GHz	+/- 3.81
Conducted Emission (Mains Terminals), 9kHz to 30MHz	+/- 2.48

Remark:

1. This uncertainty represents an expanded uncertainty expressed at approximately the 95% confidence level using a coverage factor of $k=2$
2. ISO/IEC 17025 requires that an estimate of the measurement uncertainties associated with the emissions test results be included in the report

1.5 FACILITIES AND TEST LOCATION

All measurement facilities used to collect the measurement data are located at
No. 11, Wugong 6th Rd., Wugu Dist., New Taipei City 24891, Taiwan. (R.O.C.)

Test site	Test Engineer	Remark
AC Conduction Room	Kevin Kuo	
Radiation	Kevin Kuo	
RF Conducted	Eric Lee	

Remark: The sites are constructed in conformance with the requirements of ANSI C63.7, ANSI C63.4 and CISPR Publication 22.

1.6 INSTRUMENT CALIBRATION

AC Conduction Test Room					
Name of Equipment	Manufacturer	Model	Serial Number	Calibration Date	Calibration Due
LISN	R&S	ENV216	101054	05/18/2017	05/17/2018
LISN	SCHWARZBECK	NSLK 8127	8127-541	02/14/2017	02/13/2018
EMI Test Receiver	R&S	ESCI	100064	05/17/2017	05/16/2018

Wugu 966 Chamber A					
Name of Equipment	Manufacturer	Model	Serial Number	Calibration Date	Calibration Due
Bilog Antenna	Sunol Sciences	JB3	A030105	06/20/2017	06/19/2018
EMI Test Receiver	R&S	ESCI	100064	05/17/2017	05/16/2018
Horn Antenna	ETS LINDGREN	3117	00055165	02/20/2017	02/19/2018
K Type Cable	Huber+Suhner	SUCOFLEX 102	29406/2	01/10/2017	01/09/2018
K Type Cable	Huber+Suhner	SUCOFLEX 102	22470/2	01/10/2017	01/09/2018
Pre-Amplifier	MITEQ	AMF-6F-2604 00-40-8P	985646	01/10/2017	01/09/2018
Pre-Amplifier	EMCI	EMC 012635	980151	08/01/2017	07/31/2018
Pre-Amplifier	EMEC	EM330	060609	07/31/2017	07/30/2018
Spectrum Analyzer	Agilent	E4446A	US42510252	11/27/2017	11/26/2018
Antenna Tower	CCS	CC-A-1F	N/A	N.C.R	N.C.R
Controller	CCS	CC-C-1F	N/A	N.C.R	N.C.R
Turn Table	CCS	CC-T-1F	N/A	N.C.R	N.C.R
Software	EZ-EMC (CCS-3A1RE)				

Remark:

- Each piece of equipment is scheduled for calibration once a year and Precision Dipole is scheduled for calibration once three years.
- N.C.R. = No Calibration Request.

Conducted Test Site					
Name of Equipment	Manufacturer	Model	Serial Number	Calibration Date	Calibration Due
Power Meter	Anritsu	ML2495A	1033009	04/11/2017	04/10/2018
Power Sensor	Anritsu	MA2411B	917072	07/03/2017	07/02/2018
Spectrum Analyzer	R&S	FSV 40	101073	10/02/2017	10/01/2018
Thermostatic/Hrgrosatic Chamber	GWINSTEK	GTC-288MH-CC	TH160402	05/23/2017	05/22/2018
SUCOFLEX Cable	HUBER SUHNER	SUCOFLEX 104PEA	25157	07/31/2017	07/30/2018
Divider	Solvang Technology	2-18GHz 4Way	STI08-0015	07/26/2017	07/25/2018
Coupler	Agilent	87301d	MY44350252	07/25/2017	07/24/2018

Remark:

1. Each piece of equipment is scheduled for calibration once a year and Precision Dipole is scheduled for calibration once three years.
2. N.C.R. = No Calibration Request.

1.7 SUPPORT AND EUT ACCESSORIES EQUIPMENT

No	Equipment	Brand	Model	Series No.	FCC ID	Data Cable	Power Cord
1	NB(A)	Dell	PP19L	N/A	CXSMM01BR D02D110	N/A	N/A
2	NB(H)	Acer	Aspire 4320 series	N/A	QDS-BRCM1 018	N/A	N/A

1.8 TEST METHODOLOGY AND APPLIED STANDARDS

The test methodology, setups and results comply with all requirements in accordance with ANSI C63.10:2013, FCC Part 2, FCC Part 15.407, KDB 789033 D02 v01r04, KDB 644545 D03 v01.

2. TEST SUMMERY

FCC Standard Sec.	Chapter	Test Item	Result
15.203	1.2	Antenna Requirement	Pass
15.207	4.1	AC Conducted Emission	Pass
15.407(a)	4.3	Output Power Measurement	Pass
15.407(b)	4.5	Radiation Band Edge	Pass
15.407(b)	4.5	Radiation Spurious Emission	Pass

3. DESCRIPTION OF TEST MODES

3.1 THE WORST MODE OF OPERATING CONDITION

<p>Operation mode</p>	<p>1. IEEE 802.11a mode: 6Mbps 2. IEEE 802.11n HT 20 MHz mode: MCS0 3. IEEE 802.11n HT 40 MHz mode: MCS0</p>																																												
<p>Operating Frequency Range & Number of Channels</p>	<table border="1"> <thead> <tr> <th></th> <th>Mode</th> <th>Frequency Range (MHz)</th> <th>Number of Channels</th> </tr> </thead> <tbody> <tr> <td rowspan="3">U-NII-1</td> <td>IEEE 802.11a</td> <td>5180 ~ 5240</td> <td>4 Channels</td> </tr> <tr> <td>IEEE 802.11n HT 20 MHz</td> <td>5180 ~ 5240</td> <td>4 Channels</td> </tr> <tr> <td>IEEE 802.11n HT 40 MHz</td> <td>5190 ~ 5230</td> <td>2 Channels</td> </tr> <tr> <td rowspan="3">U-NII-2a</td> <td>IEEE 802.11a</td> <td>5260 ~ 5320</td> <td>4 Channels</td> </tr> <tr> <td>IEEE 802.11n HT 20 MHz</td> <td>5260 ~ 5320</td> <td>4 Channels</td> </tr> <tr> <td>IEEE 802.11n HT 40 MHz</td> <td>5270 ~ 5310</td> <td>2 Channels</td> </tr> <tr> <td rowspan="3">U-NII-2c</td> <td>IEEE 802.11a</td> <td>5500 ~ 5700</td> <td>8 Channels</td> </tr> <tr> <td>IEEE 802.11n HT 20 MHz</td> <td>5500 ~ 5700</td> <td>8 Channels</td> </tr> <tr> <td>IEEE 802.11n HT 40 MHz</td> <td>5510 ~ 5670</td> <td>3 Channels</td> </tr> <tr> <td rowspan="3">U-NII-3</td> <td>IEEE 802.11a</td> <td>5745 ~ 5825</td> <td>5 Channels</td> </tr> <tr> <td>IEEE 802.11n HT 20 MHz</td> <td>5745 ~ 5825</td> <td>5 Channels</td> </tr> <tr> <td>IEEE 802.11n HT 40 MHz</td> <td>5755 ~ 5795</td> <td>2 Channels</td> </tr> </tbody> </table>		Mode	Frequency Range (MHz)	Number of Channels	U-NII-1	IEEE 802.11a	5180 ~ 5240	4 Channels	IEEE 802.11n HT 20 MHz	5180 ~ 5240	4 Channels	IEEE 802.11n HT 40 MHz	5190 ~ 5230	2 Channels	U-NII-2a	IEEE 802.11a	5260 ~ 5320	4 Channels	IEEE 802.11n HT 20 MHz	5260 ~ 5320	4 Channels	IEEE 802.11n HT 40 MHz	5270 ~ 5310	2 Channels	U-NII-2c	IEEE 802.11a	5500 ~ 5700	8 Channels	IEEE 802.11n HT 20 MHz	5500 ~ 5700	8 Channels	IEEE 802.11n HT 40 MHz	5510 ~ 5670	3 Channels	U-NII-3	IEEE 802.11a	5745 ~ 5825	5 Channels	IEEE 802.11n HT 20 MHz	5745 ~ 5825	5 Channels	IEEE 802.11n HT 40 MHz	5755 ~ 5795	2 Channels
	Mode	Frequency Range (MHz)	Number of Channels																																										
U-NII-1	IEEE 802.11a	5180 ~ 5240	4 Channels																																										
	IEEE 802.11n HT 20 MHz	5180 ~ 5240	4 Channels																																										
	IEEE 802.11n HT 40 MHz	5190 ~ 5230	2 Channels																																										
U-NII-2a	IEEE 802.11a	5260 ~ 5320	4 Channels																																										
	IEEE 802.11n HT 20 MHz	5260 ~ 5320	4 Channels																																										
	IEEE 802.11n HT 40 MHz	5270 ~ 5310	2 Channels																																										
U-NII-2c	IEEE 802.11a	5500 ~ 5700	8 Channels																																										
	IEEE 802.11n HT 20 MHz	5500 ~ 5700	8 Channels																																										
	IEEE 802.11n HT 40 MHz	5510 ~ 5670	3 Channels																																										
U-NII-3	IEEE 802.11a	5745 ~ 5825	5 Channels																																										
	IEEE 802.11n HT 20 MHz	5745 ~ 5825	5 Channels																																										
	IEEE 802.11n HT 40 MHz	5755 ~ 5795	2 Channels																																										

Remark:

1. EUT pre-scanned data rate of output power for each mode, the worst data rate were recorded in this report.
2. Covered modes are test reduction modes. The output powers on the covered modes are equal to or less than the mode referenced and use the same module
3. The mode IEEE 802.11ac VHT20 and VHT40 are only different in control messages with IEEE 802.11n HT20 and HT40, and have same power setting. Therefore, the highest power(IEEE 802.11n HT20 and HT40) were test conducted and radiated measurement and recorded in this report.

3.2 THE WORST MODE OF MEASUREMENT

AC Power Line Conducted Emission	
Test Condition	AC Power line conducted emission for line and neutral
Voltage/Hz	3.8V
Test Mode	Mode 1:EUT power by Battery.
Worst Mode	<input checked="" type="checkbox"/> Mode 1 <input type="checkbox"/> Mode 2 <input type="checkbox"/> Mode 3 <input type="checkbox"/> Mode 4

Radiated Emission Measurement Above 1G	
Test Condition	Band edge, Emission for Unwanted and Fundamental
Voltage/Hz	3.8V
Test Mode	Mode 1:EUT power by Battery.
Worst Mode	<input checked="" type="checkbox"/> Mode 1 <input type="checkbox"/> Mode 2 <input type="checkbox"/> Mode 3 <input type="checkbox"/> Mode 4
Worst Position	<input type="checkbox"/> Placed in fixed position. <input type="checkbox"/> Placed in fixed position at X-Plane (E2-Plane) <input type="checkbox"/> Placed in fixed position at Y-Plane (E1-Plane) <input checked="" type="checkbox"/> Placed in fixed position at Z-Plane (H-Plane)
Worst Polarity	<input type="checkbox"/> Horizontal <input checked="" type="checkbox"/> Vertical

Radiated Emission Measurement Below 1G	
Test Condition	Radiated Emission Below 1G
Voltage/Hz	3.8V
Test Mode	Mode 1:EUT power by Battery.
Worst Mode	<input checked="" type="checkbox"/> Mode 1 <input type="checkbox"/> Mode 2 <input type="checkbox"/> Mode 3 <input type="checkbox"/> Mode 4

Remark:

- 1. The worst mode was record in this test report.*
- 2. EUT pre-scanned in three axis ,X, Y, Z and two polarity, Horizontal and Vertical for radiated measurement. The worst case(Z-Plane and Vertical) were recorded in this report*
- 3. For below 1G, AC power line conducted emission and radiation emission were performed the EUT transmit at the highest output power channel as worse case.*

3.3 EUT DUTY CYCLE

Duty Cycle				
Configuration	TX ON (ms)	TX ALL (ms)	Duty Cycle (%)	Duty Factor(dB)
802.11a	1.000	1.000	100.00%	0.00
802.11n HT20	1.000	1.000	100.00%	0.00
802.11n HT40	1.000	1.000	100.00%	0.00

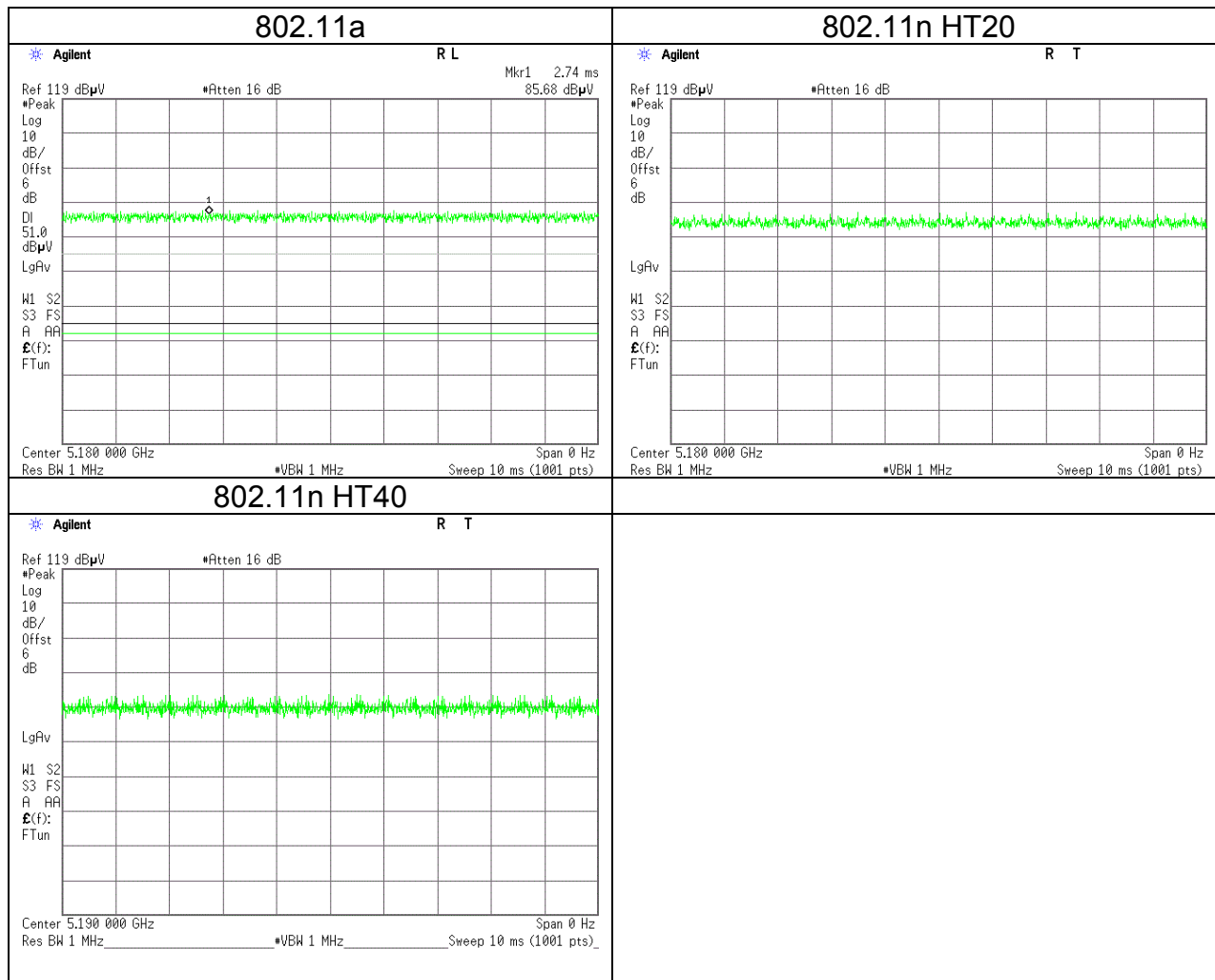

4. TEST RESULT

4.1 AC POWER LINE CONDUCTED EMISSION

4.1.1 Test Limit

According to §15.207(a)

Frequency Range (MHz)	Limits(dBμV)	
	Quasi-peak	Average
0.15 to 0.50	66 to 56*	56 to 46*
0.50 to 5	56	46
5 to 30	60	50

* Decreases with the logarithm of the frequency.

4.1.2 Test Procedure

Test method Refer as ANSI 63.10:2013 clause 6.2,

1. The EUT was placed on a non-conducted table, which is 0.8m above horizontal ground plane and 0.4m above vertical ground plane.
2. EUT connected to the line impedance stabilization network (LISN)
3. Receiver set RBW of 9kHz and Detector Peak, and note as quasi-peak and average.
4. Maximum procedure was performed on the six highest emissions to ensure EUT compliance.
5. Recorded Line for Neutral and Line.

4.1.3 Test Setup

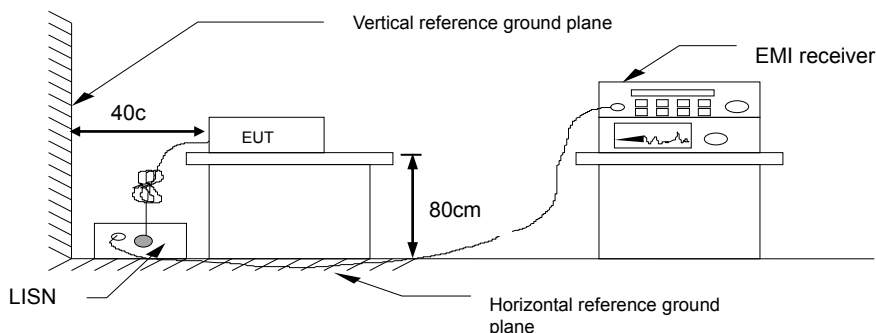

4.1.4 Test Result

Pass.

Test Data

Test Mode:	Mode 1	Temp/Hum	24.5(°C)/ 52.1%RH
Test Voltage:	120Vac / 60Hz	Test Date	November 30, 2017
Phase:	Line	Test Engineer	Kevin Kuo

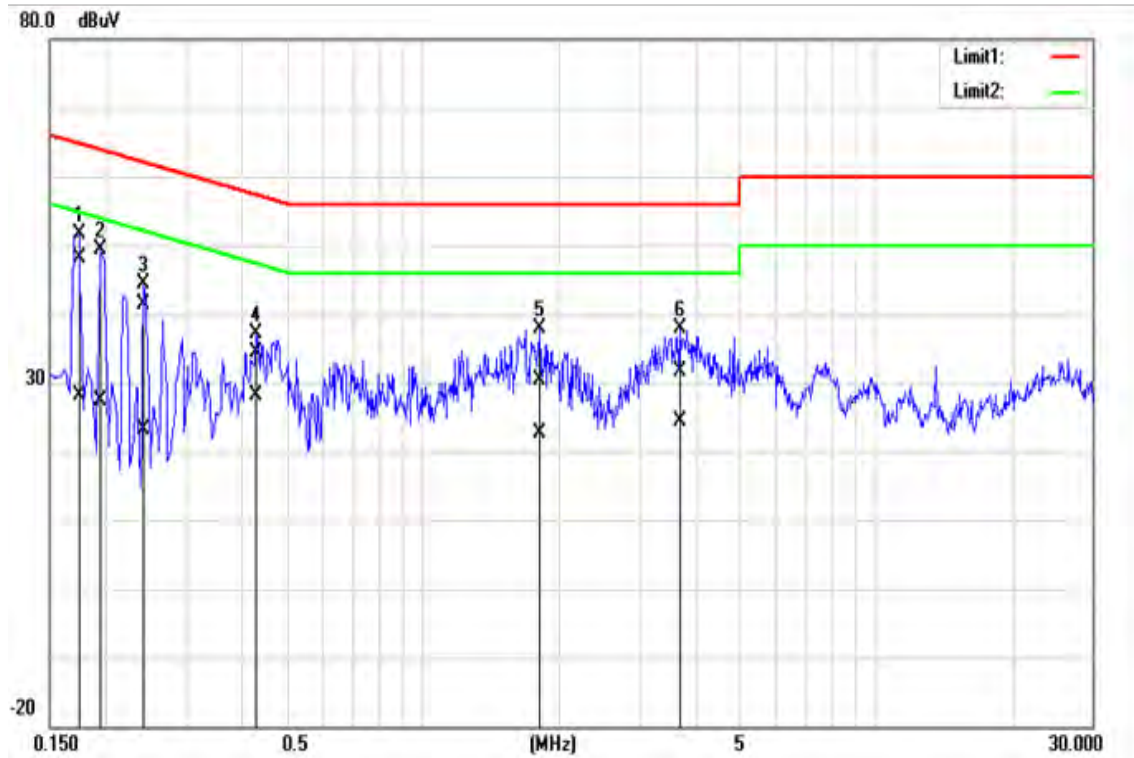

No.	Frequency (MHz)	QuasiPeak reading (dBuV)	Average reading (dBuV)	Correction factor (dB)	QuasiPeak result (dBuV)	Average result (dBuV)	QuasiPeak limit (dBuV)	Average limit (dBuV)	QuasiPeak margin (dB)	Average margin (dB)
1	0.1740	48.09	28.13	0.08	48.17	28.21	64.77	54.77	-16.60	-26.56
2	0.1940	49.21	27.27	0.09	49.30	27.36	63.86	53.86	-14.56	-26.50
3	0.2420	41.41	22.93	0.09	41.50	23.02	62.03	52.03	-20.53	-29.01
4	0.4300	34.33	28.15	0.10	34.43	28.25	57.25	47.25	-22.82	-19.00
5	1.8100	30.34	22.48	0.16	30.50	22.64	56.00	46.00	-25.50	-23.36
6	3.6820	31.37	24.21	0.22	31.59	24.43	56.00	46.00	-24.41	-21.57

Test Mode:	Mode 1	Temp/Hum	24.5(°C)/ 52.1%RH
Test Voltage:	120Vac / 60Hz	Test Date	November 30, 2017
Phase:	Neutral	Test Engineer	Kevin Kuo

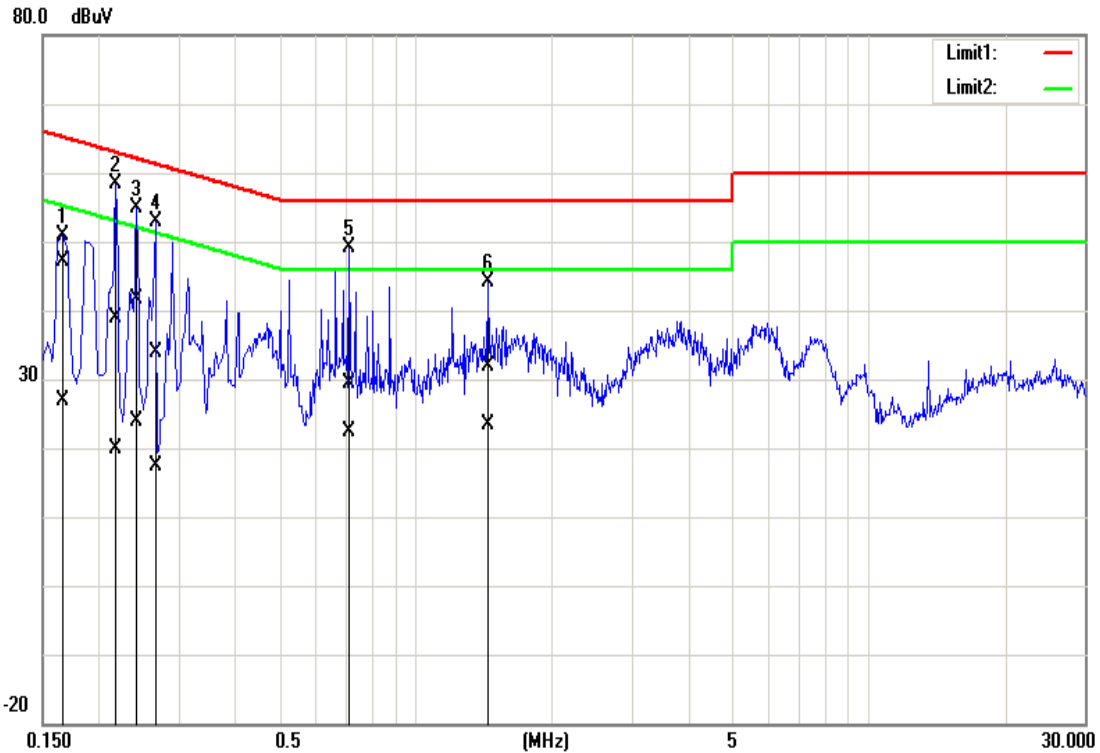

No.	Frequency (MHz)	QuasiPeak reading (dBuV)	Average reading (dBuV)	Correction factor (dB)	QuasiPeak result (dBuV)	Average result (dBuV)	QuasiPeak limit (dBuV)	Average limit (dBuV)	QuasiPeak margin (dB)	Average margin (dB)
1	0.1660	47.06	26.64	0.15	47.21	26.79	65.16	55.16	-17.95	-28.37
2	0.2180	38.65	19.64	0.16	38.81	19.80	62.89	52.89	-24.08	-33.09
3	0.2420	41.40	23.63	0.16	41.56	23.79	62.03	52.03	-20.47	-28.24
4	0.2660	33.84	17.12	0.16	34.00	17.28	61.24	51.24	-27.24	-33.96
5	0.7140	29.19	22.29	0.20	29.39	22.49	56.00	46.00	-26.61	-23.51
6	1.4460	31.60	23.09	0.22	31.82	23.31	56.00	46.00	-24.18	-22.69

4.2 OUTPUT POWER MEASUREMENT

4.2.1 Test Limit

According to §15.407 (a)(1), 15.407(a)(2) and 15.407(a)(3)

UNII-1 :

For client devices in the 5.15-5.25 GHz band, the maximum conducted output power over the frequency band of operation shall not exceed 250 mW provided the maximum antenna gain does not exceed 6 dBi. In addition, the maximum power spectral density shall not exceed 11 dBm in any 1 megahertz band. If transmitting antennas of directional gain greater than 6 dBi are used, both the maximum conducted output power and the maximum power spectral density shall be reduced by the amount in dB that the directional gain of the antenna exceeds 6 dBi.

UNII-2a and 2c:

the maximum conducted output power over the frequency bands of operation shall not exceed the lesser of 250 mW or 11 dBm + 10 log B, where B is the 26 dB emission bandwidth in megahertz. In addition, the maximum power spectral density shall not exceed 11 dBm in any 1 megahertz band. If transmitting antennas of directional gain greater than 6 dBi are used, both the maximum conducted output power and the maximum power spectral density shall be reduced by the amount in dB that the directional gain of the antenna exceeds 6 dBi.

UNII-3:

For the band 5.725-5.85 GHz, the maximum conducted output power over the frequency band of operation shall not exceed 1 W. In addition, the maximum power spectral density shall not exceed 30 dBm in any 500-kHz band. If transmitting antennas of directional gain greater than 6 dBi are used, both the maximum conducted output power and the maximum power spectral density shall be reduced by the amount in dB that the directional gain of the antenna exceeds 6 dBi.

UNII-1 Limit	<input checked="" type="checkbox"/> Antenna not exceed 6 dBi : 24dBm <input type="checkbox"/> Antenna with DG greater than 6 dBi : [Limit = 30 – (DG – 6)]
UNII-2a/2c Limit	<input checked="" type="checkbox"/> Antenna not exceed 6 dBi : 24dBm <input type="checkbox"/> Antenna with DG greater than 6 dBi : [Limit = 30 – (DG – 6)]
UNII-3 Limit	<input checked="" type="checkbox"/> Antenna not exceed 6 dBi : 30dBm <input type="checkbox"/> Antenna with DG greater than 6 dBi : [Limit = 30 – (DG – 6)]

4.2.2 Test Procedure

Test method Refer as KDB 789033 D02 v01r04, Section E.3.b.

1. The EUT RF output connected to the power meter by RF cable.
2. Setting maximum power transmit of EUT.
3. The path loss was compensated to the results for each measurement.
4. Measure and record the result of Average output power. in the test report.

4.2.3 Test Setup

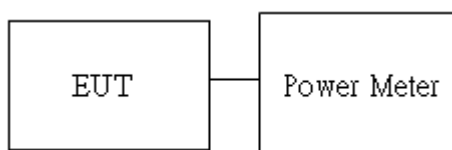

4.2.4 Test Result

Conducted output power :

UNII-1										
Config	CH	Freq. (MHz)	Power Set		AV Power(dBm)		AV Total Power (dBm)	AV Total Power (W)	DG (dBi)	Limit (dBm)
			chain0	chain1	chain0	chain1				
IEEE 802.11a	36	5180	56	-	11.38	-	11.38	0.0137	1.5	24
	44	5220	54	-	11.49	-	11.49	0.0141		
	48	5240	54	-	11.87	-	11.87	0.0154		
IEEE 802.11n HT20	36	5180	55	-	11.75	-	11.75	0.0150		
	44	5220	54	-	11.58	-	11.58	0.0144		
	48	5240	54	-	11.77	-	11.77	0.0150		
IEEE 802.11n HT40	38	5190	56	-	11.45	-	11.45	0.0140		
	46	5230	55	-	11.57	-	11.57	0.0144		

UNII-2a										
Config	CH	Freq. (MHz)	Power Set		AV Power(dBm)		AV Total Power (dBm)	AV Total Power (W)	DG (dBi)	Limit (dBm)
			chain0	chain1	chain0	chain1				
IEEE 802.11a	52	5260	50	-	11.35	-	11.35	0.0136	1.5	24
	56	5280	49	-	11.84	-	11.84	0.0153		
	64	5320	48	-	11.28	-	11.28	0.0134		
IEEE 802.11n HT20	52	5260	50	-	11.45	-	11.45	0.0140		
	56	5280	50	-	11.38	-	11.38	0.0137		
	64	5320	49	-	11.87	-	11.87	0.0154		
IEEE 802.11n HT40	54	5270	51	-	11.36	-	11.36	0.0137		
	62	5310	51	-	12.36	-	12.36	0.0172		

UNII-2c										
Config	CH	Freq. (MHz)	Power Set		AV Power(dBm)		AV Total Power (dBm)	AV Total Power (W)	DG (dBi)	Limit (dBm)
			chain0	chain1	chain0	chain1				
IEEE 802.11a	100	5500	55	-	11.58	-	11.58	0.0144	1.5	24
	116	5580	52	-	11.67	-	11.67	0.0147		
	140	5700	49	-	10.78	-	10.78	0.0120		
IEEE 802.11n HT20	100	5500	55	-	11.67	-	11.67	0.0147		
	116	5580	52	-	11.89	-	11.89	0.0155		
	140	5700	48	-	11.88	-	11.88	0.0154		
IEEE 802.11n HT40	102	5510	56	-	12.21	-	12.21	0.0166		
	110	5550	55	-	12.36	-	12.36	0.0172		
	134	5670	52	-	12.49	-	12.49	0.0177		

UNII-3										
Config	CH	Freq. (MHz)	Power Set		AV Power(dBm)		AV Total Power (dBm)	AV Total Power (W)	DG (dBi)	Limit (dBm)
			chain0	chain1	chain0	chain1				
IEEE 802.11a	149	5745	48	-	11.75	-	11.75	0.0150	1.5	30
	157	5785	48	-	11.87	-	11.87	0.0154		
	165	5825	47	-	11.57	-	11.57	0.0144		
IEEE 802.11n HT20	149	5475	48	-	11.56	-	11.56	0.0143		
	7	5785	48	-	11.35	-	11.35	0.0136		
	165	5825	47	-	11.87	-	11.87	0.0154		
IEEE 802.11n HT40	151	5755	52	-	12.82	-	12.82	0.0191		
	159	5795	51	-	12.06	-	12.06	0.0161		

4.3 RADIATION BANDEGE AND SPURIOUS EMISSION

4.3.1 Test Limit

According to §15.407, §15.209 and §15.205,

Below 30 MHz

Frequency	Field Strength (microvolts/m)	Magnetic H-Field (microamperes/m)	Measurement Distance (metres)
9-490 kHz	2,400/F (F in kHz)	2,400/F (F in kHz)	300
490-1,705 kHz	24,000/F (F in kHz)	24,000/F (F in kHz)	30
1.705-30 MHz	30	N/A	30

Above 30 MHz

Frequency (MHz)	Field Strength microvolts/m at 3 metres (watts, e.i.r.p.)	
	Transmitters	Receivers
30-88	100 (3 nW)	100 (3 nW)
88-216	150 (6.8 nW)	150 (6.8 nW)
216-960	200 (12 nW)	200 (12 nW)
Above 960	500 (75 nW)	500 (75 nW)

4.3.2 Test Procedure

Test method Refer as KDB 789033 D02 v01r04, Section G.3, G.4, G.5, and G.6,.

1. The EUT is placed on a turntable, Above 1 GHz is 1.5m and below 1 GHz is 0.8m above ground plane. The EUT Configured un accordance with ANSI C63.10, and the EUT set in a continuous mode.
2. The turntable shall be rotated for 360 degrees to determine the position of maximum emission level. And EUT is set 3m away from the receiving antenna, which is scanned from 1m to 4m above the ground plane to find out the highest emissions. Measurement are made polarized in both the vertical and the horizontal positions with antenna.
3. Span shall wide enough to full capture the emission measured. The SA from 30MHz to 26.5GHz set to the low, Mid and High channels with the EUT transmit.
5. The SA setting following :
 - (1) Below 1G : RBW = 100kHz, VBW ≥ 3*RBW, Sweep = Auto, Detector = Peak, Trace = Max hold.
 - (2) Above 1G :
 - (2.1) For Peak measurement : RBW = 1MHz, VBW ≥ 3 RBW, Sweep = Auto, Detector = Peak, Trace = Max hold.
 - (2.2) For Average measurement : RBW = 1MHz, VBW
 - If Duty Cycle ≥ 98%, VBW=10Hz.
 - If Duty Cycle < 98%, VBW=1/T.

Configuration	Duty Cycle (%)	VBW
802.11a	100.00%	10Hz
802.11n HT20	100.00%	10Hz
802.11n HT40	100.00%	10Hz

4.3.3 Test Setup

9kHz ~ 30MHz

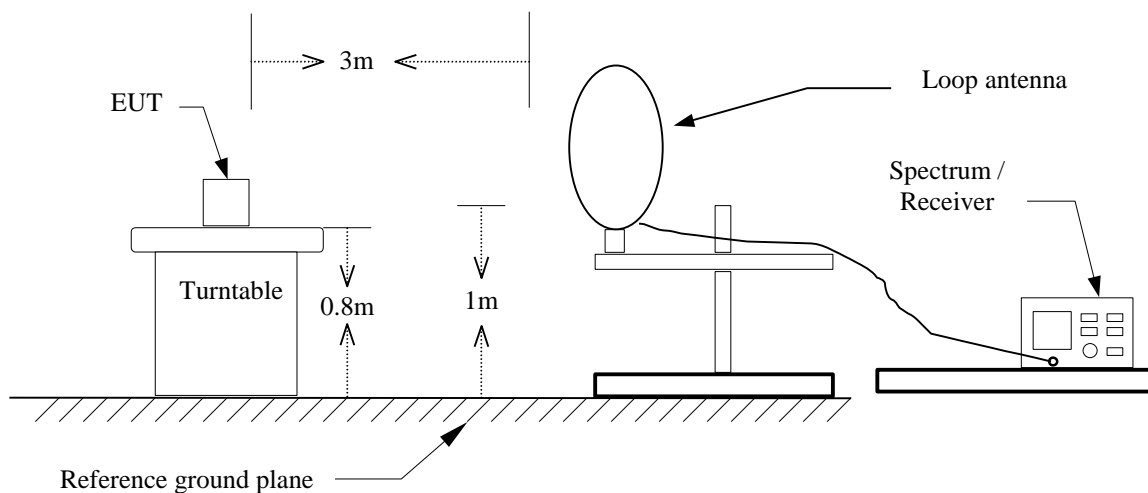

Note: No emission found between lowest internal used/generated frequency to 30MHz(9KHz~30MHz)

30MHz ~ 1GHz

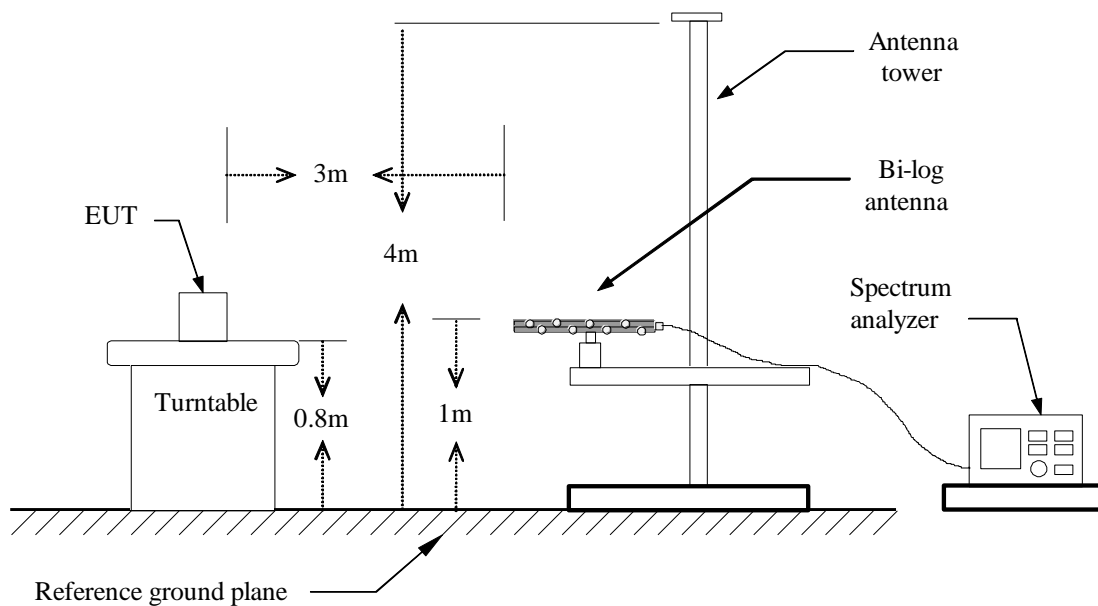

Above 1 GHz

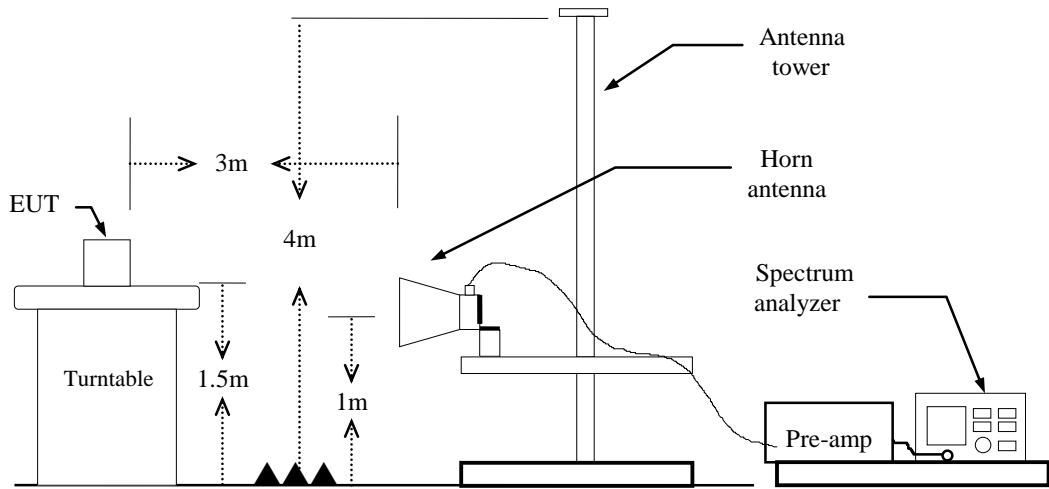

4.3.4 Test Result

Test Data

Band Edge Test Data for UNII-1

Test Mode	IEEE 802.11a Low CH	Temp/Hum	24(°C)/ 33%RH
Test Item	Band Edge	Test Date	December 1, 2017
Polarize	Vertical	Test Engineer	Kevin Kuo
Detector	Peak		

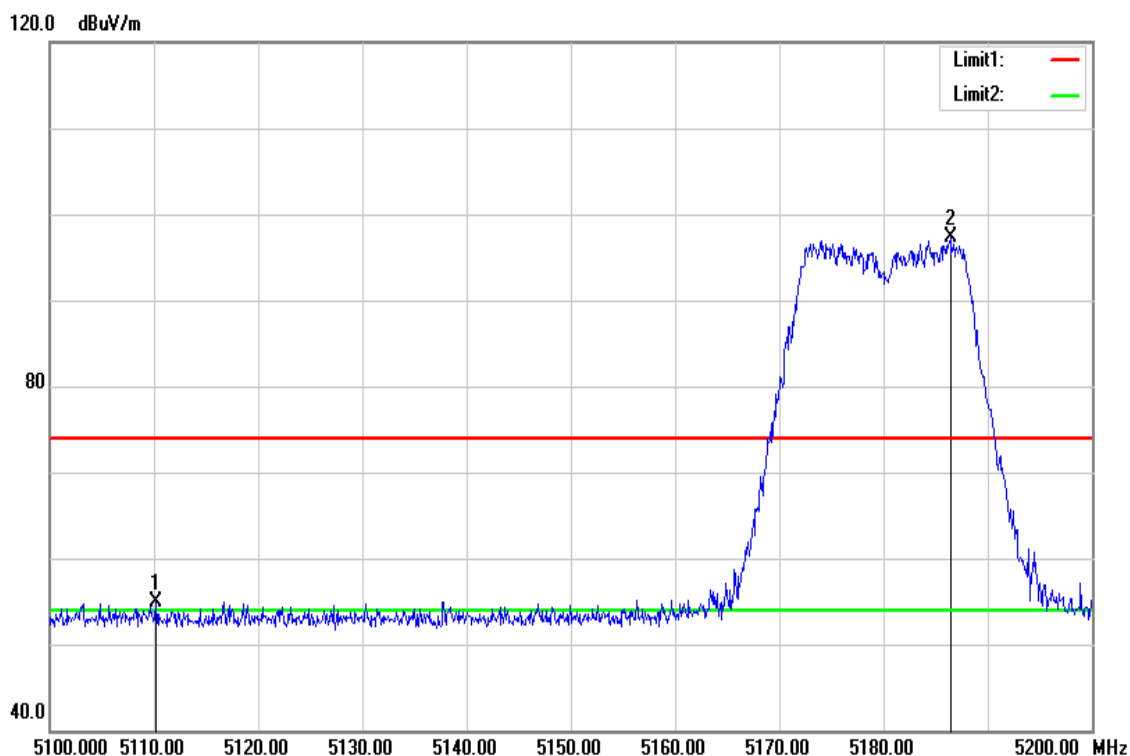

Frequency (MHz)	Reading (dBuV)	Correct Factor (dB/m)	Result (dBuV/m)	Limit (dBuV/m)	Margin (dB)	Remark
5110.200	49.97	4.97	54.94	74.00	-19.06	peak
5186.400	92.06	5.15	97.21	-	-	peak

Test Mode	IEEE 802.11a Low CH	Temperature	24(°C)/ 33%RH
Test Item	Band Edge	Test Date	December 1, 2017
Polarize	Vertical	Test Engineer	Kevin Kuo
Detector	Average		

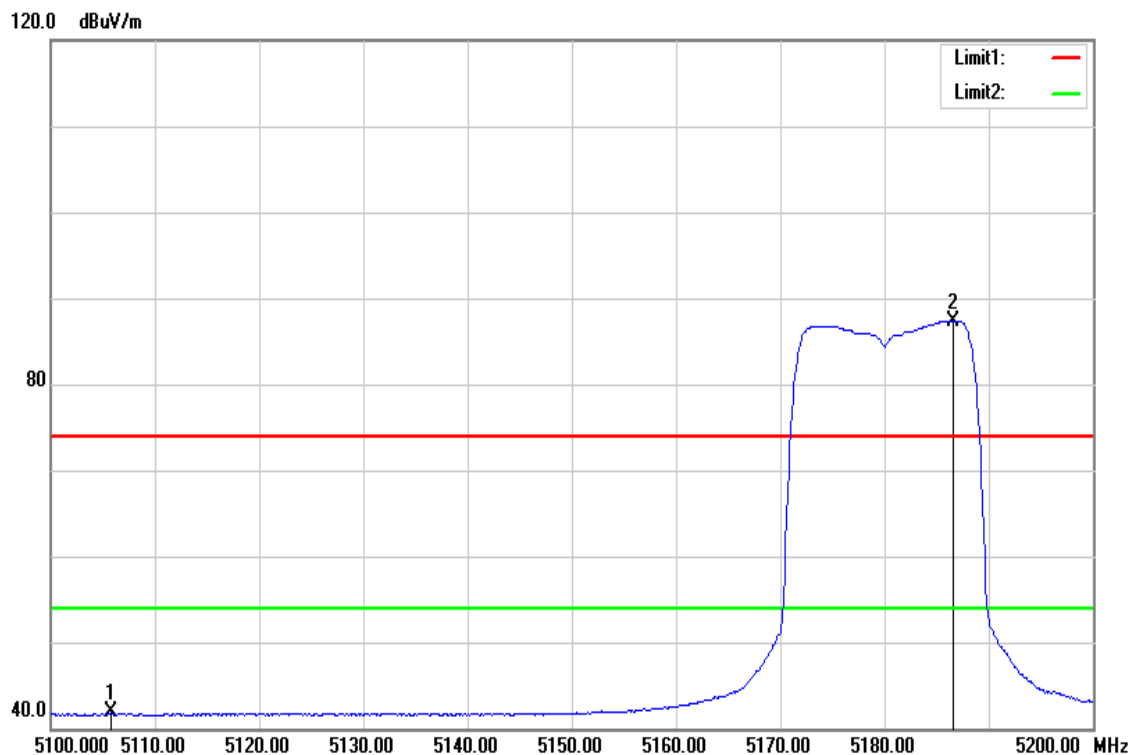

Frequency (MHz)	Reading (dBuV)	Correct Factor (dB/m)	Result (dBuV/m)	Limit (dBuV/m)	Margin (dB)	Remark
5105.800	36.86	4.95	41.81	54.00	-12.19	AVG
5186.600	82.20	5.15	87.35	-	-	AVG

Test Mode	IEEE 802.11a High CH	Temp/Hum	24(°C)/ 33%RH
Test Item	Band Edge	Test Date	December 1, 2017
Polarize	Vertical	Test Engineer	Kevin Kuo
Detector	Peak		

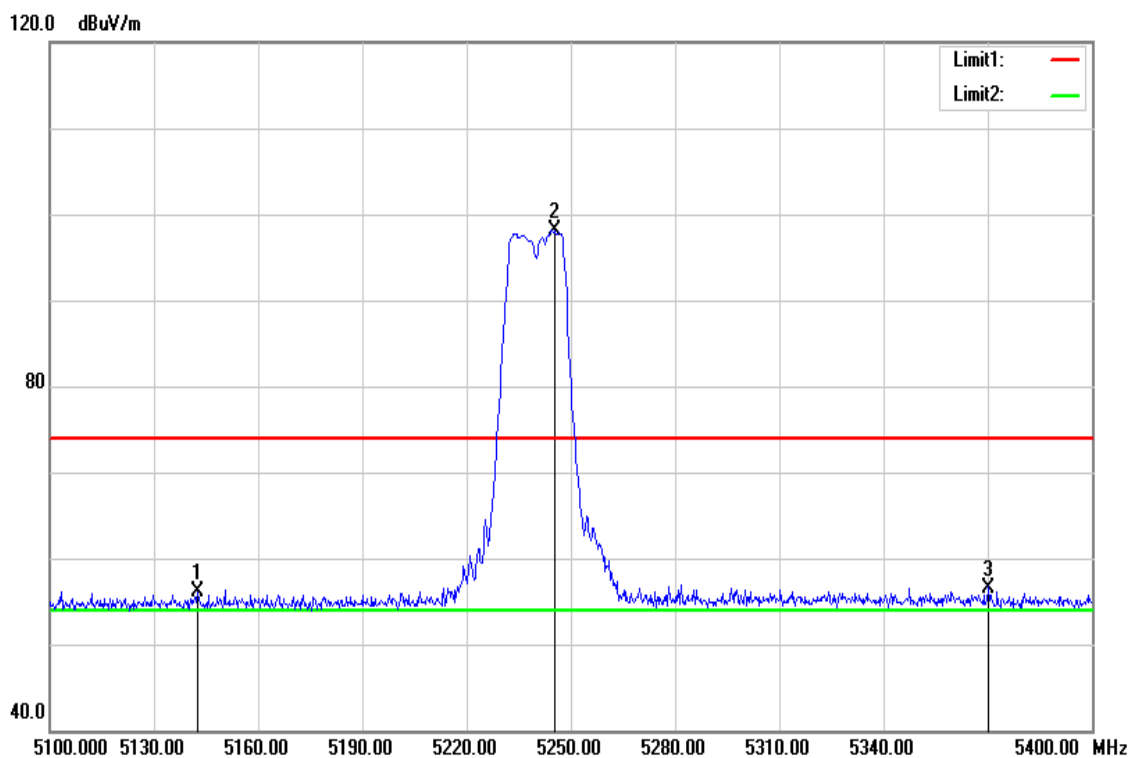

Frequency (MHz)	Reading (dBuV)	Correct Factor (dB/m)	Result (dBuV/m)	Limit (dBuV/m)	Margin (dB)	Remark
5142.600	50.97	5.05	56.02	74.00	-17.98	peak
5245.200	92.86	5.31	98.17	-	-	peak
5370.300	50.99	5.61	56.60	74.00	-17.40	peak

Test Mode	IEEE 802.11a High CH	Temperature	24(°C)/ 33%RH
Test Item	Band Edge	Test Date	December 1, 2017
Polarize	Vertical	Test Engineer	Kevin Kuo
Detector	Average		

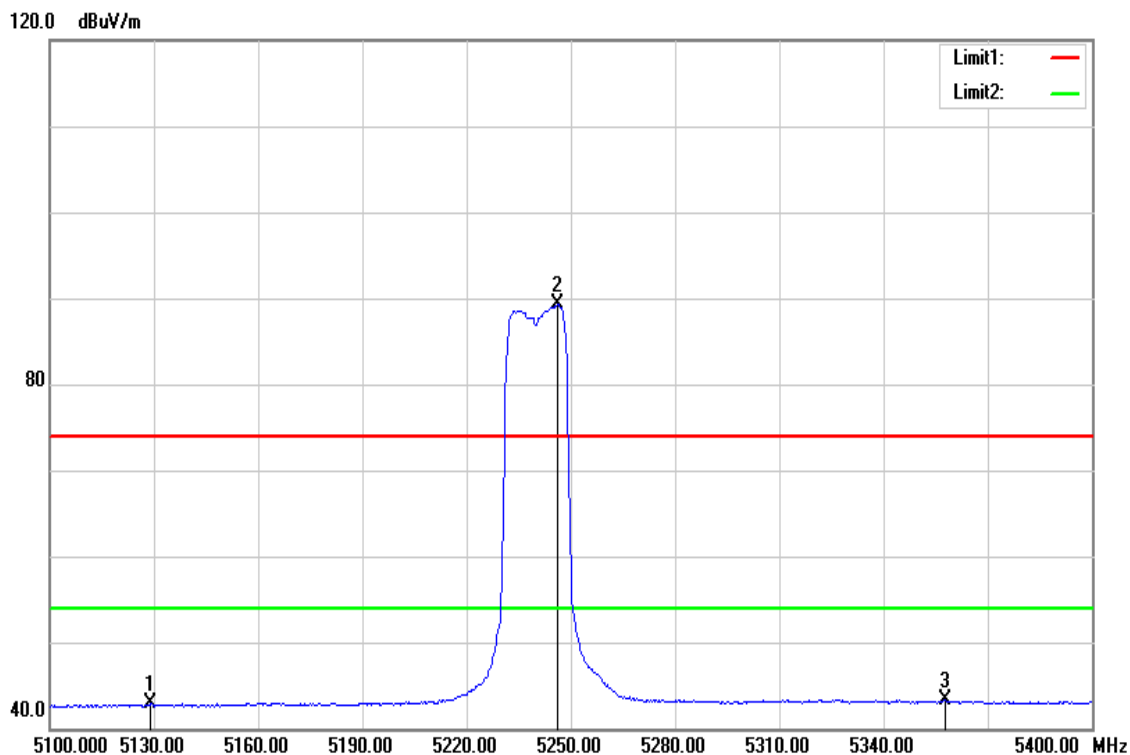

Frequency (MHz)	Reading (dBuV)	Correct Factor (dB/m)	Result (dBuV/m)	Limit (dBuV/m)	Margin (dB)	Remark
5129.100	37.82	5.01	42.83	54.00	-11.17	AVG
5246.100	83.91	5.31	89.22	-	-	AVG
5357.700	37.68	5.57	43.25	54.00	-10.75	AVG

Test Mode	IEEE 802.11n HT20 Low CH	Temp/Hum	24(°C)/ 33%RH
Test Item	Band Edge	Test Date	December 1, 2017
Polarize	Vertical	Test Engineer	Kevin Kuo
Detector	Peak		

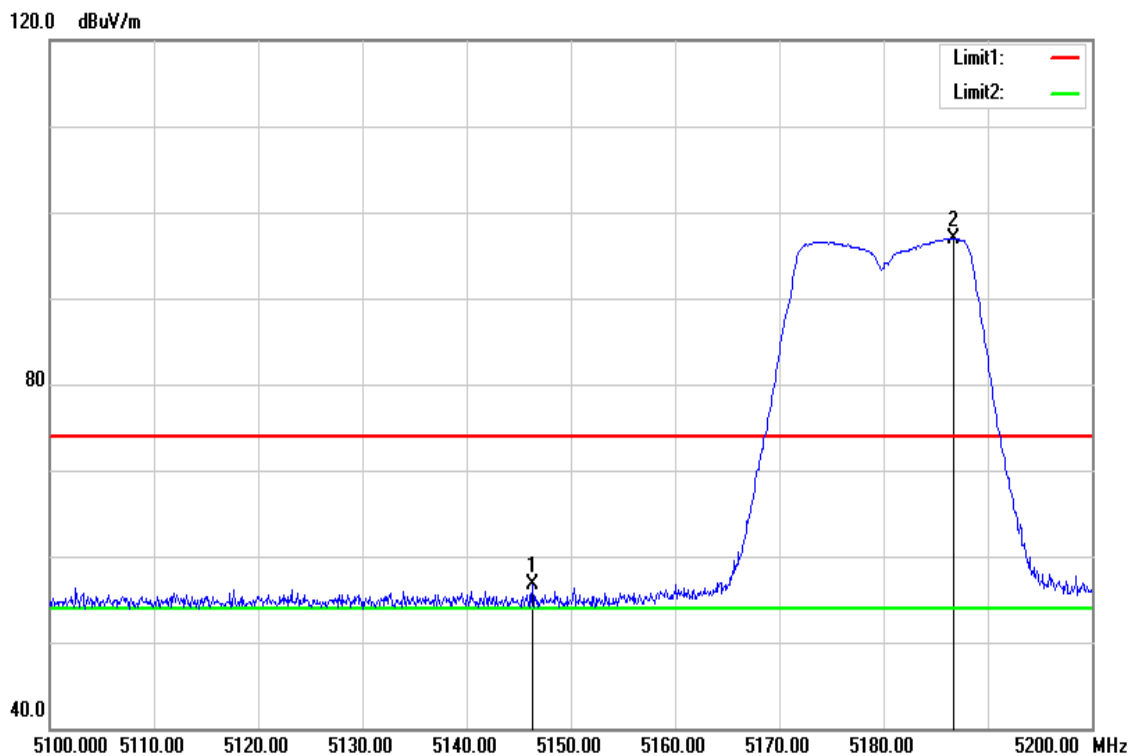

Frequency (MHz)	Reading (dBuV)	Correct Factor (dB/m)	Result (dBuV/m)	Limit (dBuV/m)	Margin (dB)	Remark
5146.300	51.67	5.06	56.73	74.00	-17.27	peak
5186.700	91.78	5.15	96.93	-	-	peak

Test Mode	IEEE 802.11n HT20 Low CH	Temperature	24(°C)/ 33%RH
Test Item	Band Edge	Test Date	December 1, 2017
Polarize	Vertical	Test Engineer	Kevin Kuo
Detector	Average		

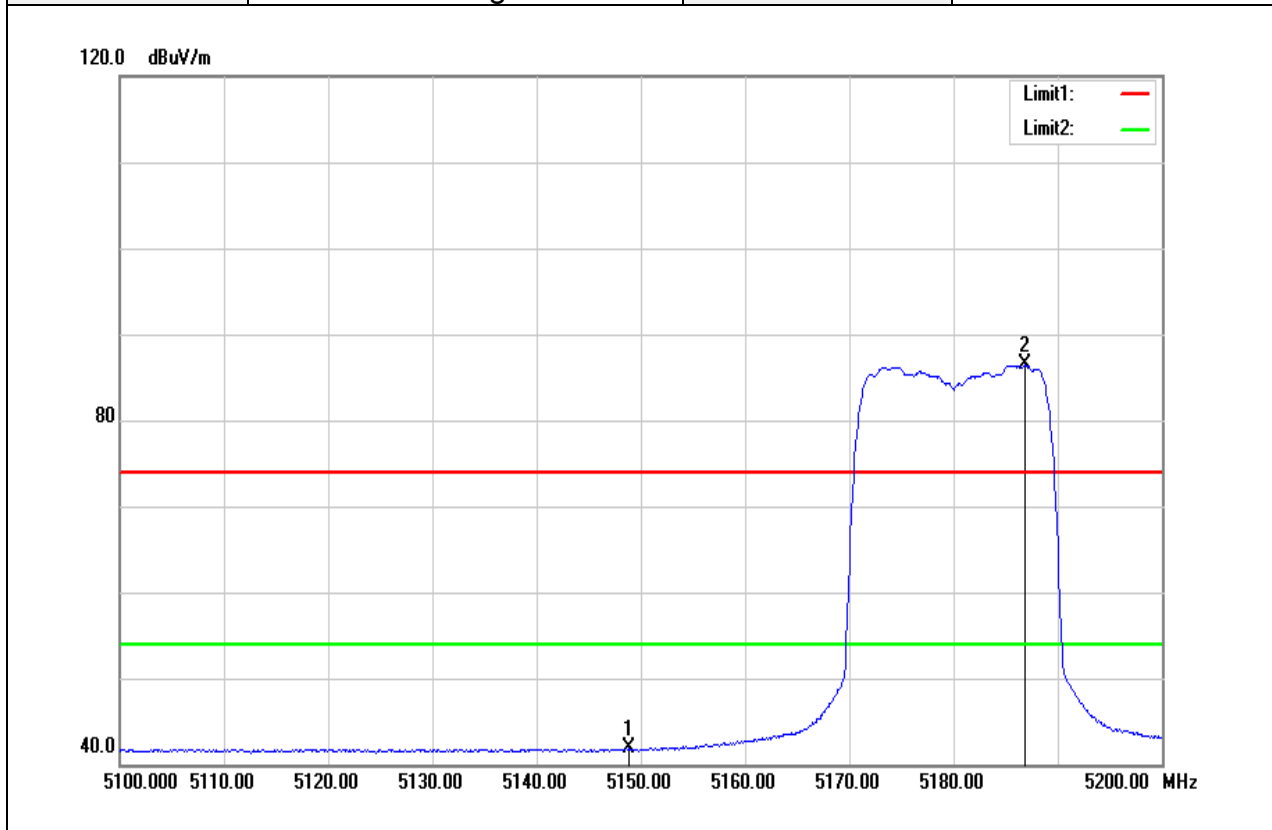

Frequency (MHz)	Reading (dBuV)	Correct Factor (dB/m)	Result (dBuV/m)	Limit (dBuV/m)	Margin (dB)	Remark
5148.800	36.78	5.06	41.84	54.00	-12.16	AVG
5186.900	81.27	5.15	86.42	-	-	AVG

Test Mode	IEEE 802.11n HT20 High CH	Temp/Hum	24(°C)/ 33%RH
Test Item	Band Edge	Test Date	December 1, 2017
Polarize	Vertical	Test Engineer	Kevin Kuo
Detector	Peak		

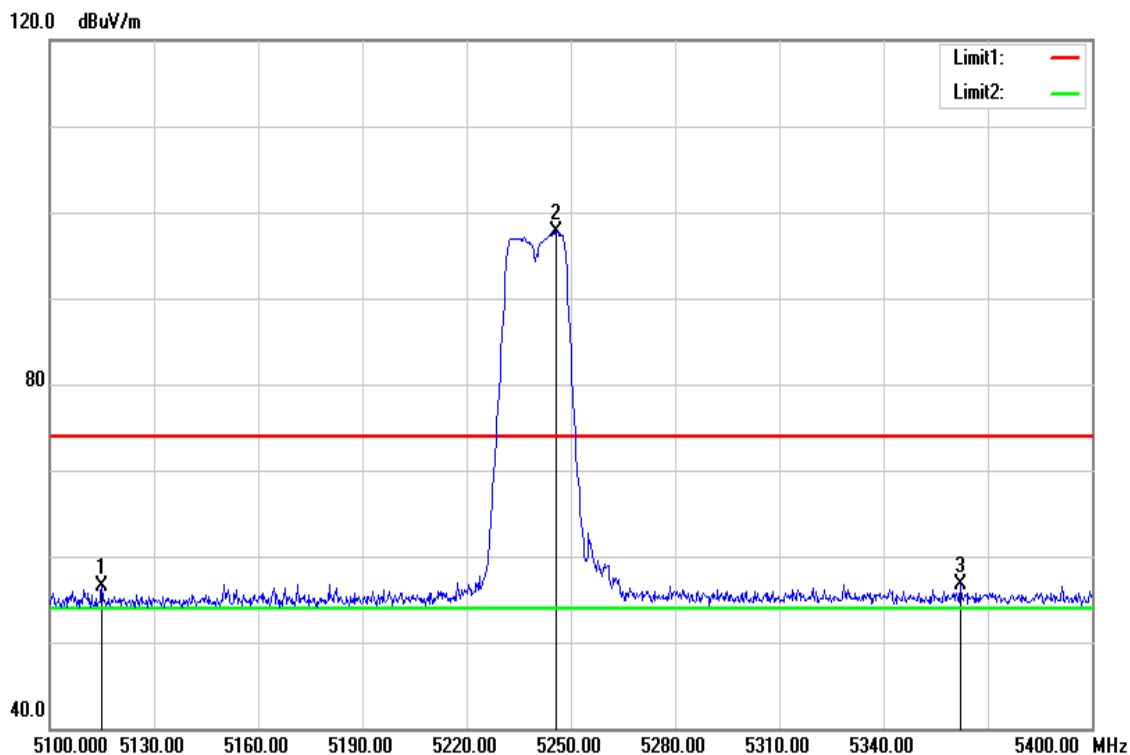

Frequency (MHz)	Reading (dBuV)	Correct Factor (dB/m)	Result (dBuV/m)	Limit (dBuV/m)	Margin (dB)	Remark
5115.000	51.49	4.98	56.47	74.00	-17.53	peak
5245.800	92.36	5.31	97.67	-	-	peak
5362.200	51.03	5.59	56.62	74.00	-17.38	peak

Test Mode	IEEE 802.11n HT20 High CH	Temperature	24(°C)/ 33%RH
Test Item	Band Edge	Test Date	December 1, 2017
Polarize	Vertical	Test Engineer	Kevin Kuo
Detector	Average		

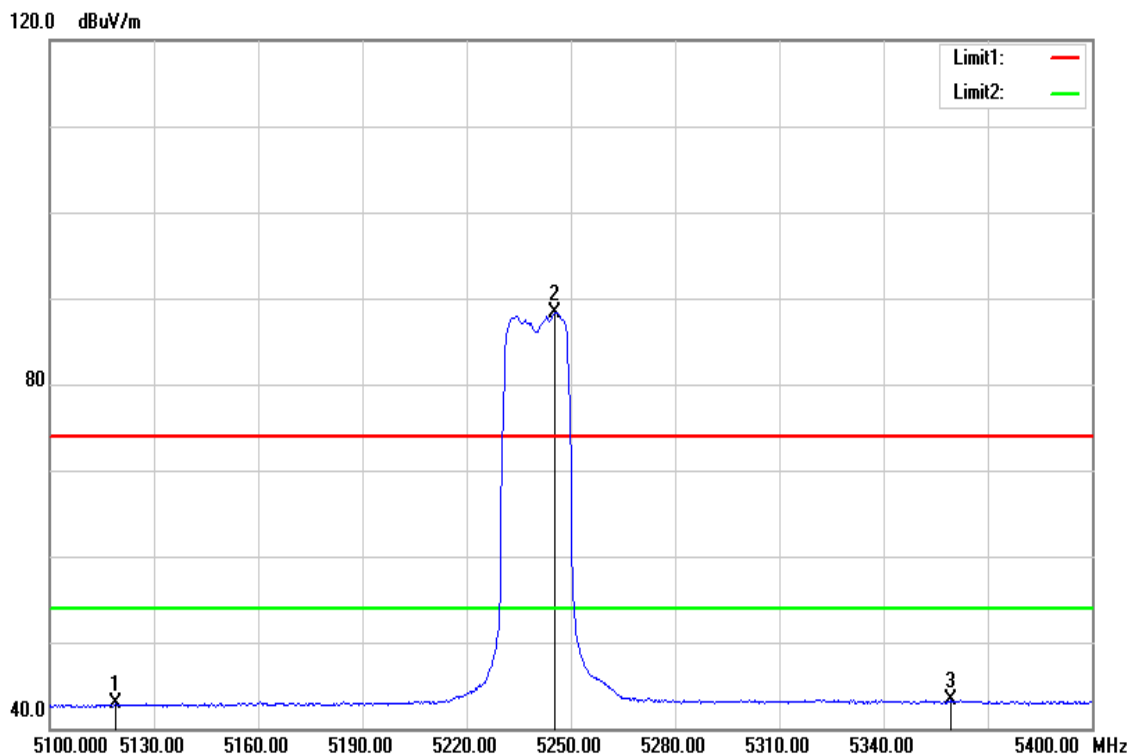

Frequency (MHz)	Reading (dBuV)	Correct Factor (dB/m)	Result (dBuV/m)	Limit (dBuV/m)	Margin (dB)	Remark
5118.900	37.86	4.98	42.84	54.00	-11.16	AVG
5245.500	83.00	5.31	88.31	-	-	AVG
5359.500	37.66	5.59	43.25	54.00	-10.75	AVG

Test Mode	IEEE 802.11n HT40 Low CH	Temp/Hum	24(°C)/ 33%RH
Test Item	Band Edge	Test Date	December 1, 2017
Polarize	Vertical	Test Engineer	Kevin Kuo
Detector	Peak		

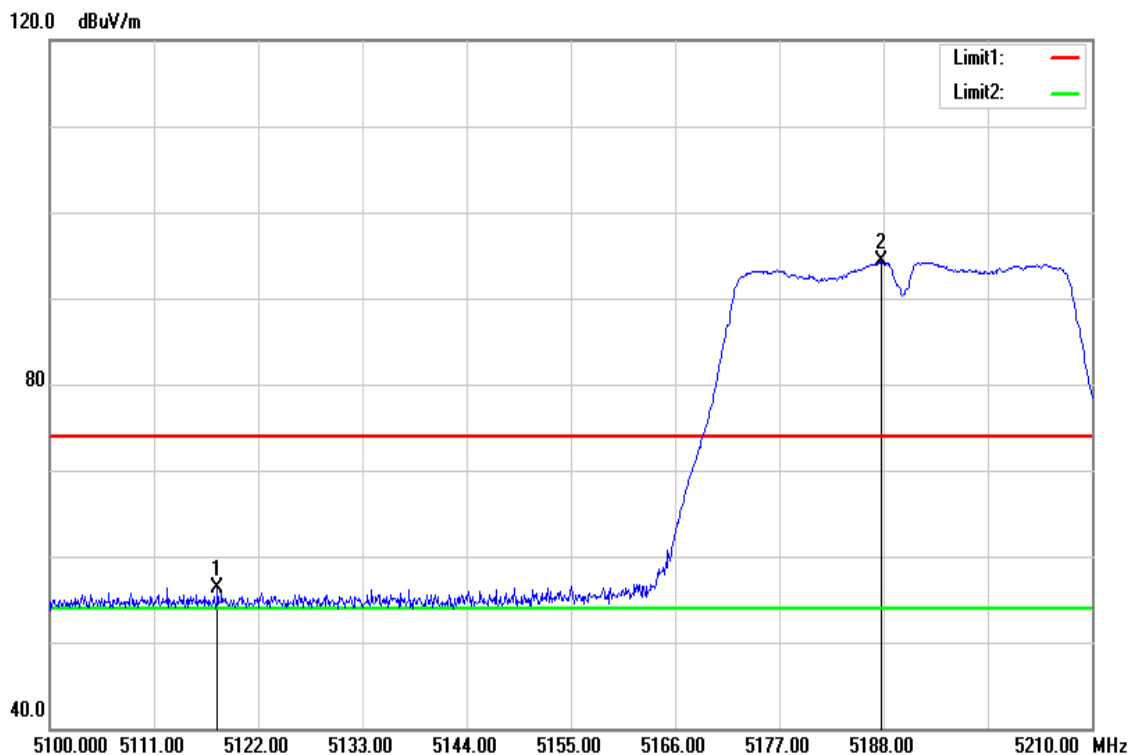

Frequency (MHz)	Reading (dBuV)	Correct Factor (dB/m)	Result (dBuV/m)	Limit (dBuV/m)	Margin (dB)	Remark
5117.710	51.34	4.98	56.32	74.00	-17.68	peak
5187.780	89.09	5.16	94.25	-	-	peak

Test Mode	IEEE 802.11n HT40 Low CH	Temperature	24(°C)/ 33%RH
Test Item	Band Edge	Test Date	December 1, 2017
Polarize	Vertical	Test Engineer	Kevin Kuo
Detector	Average		

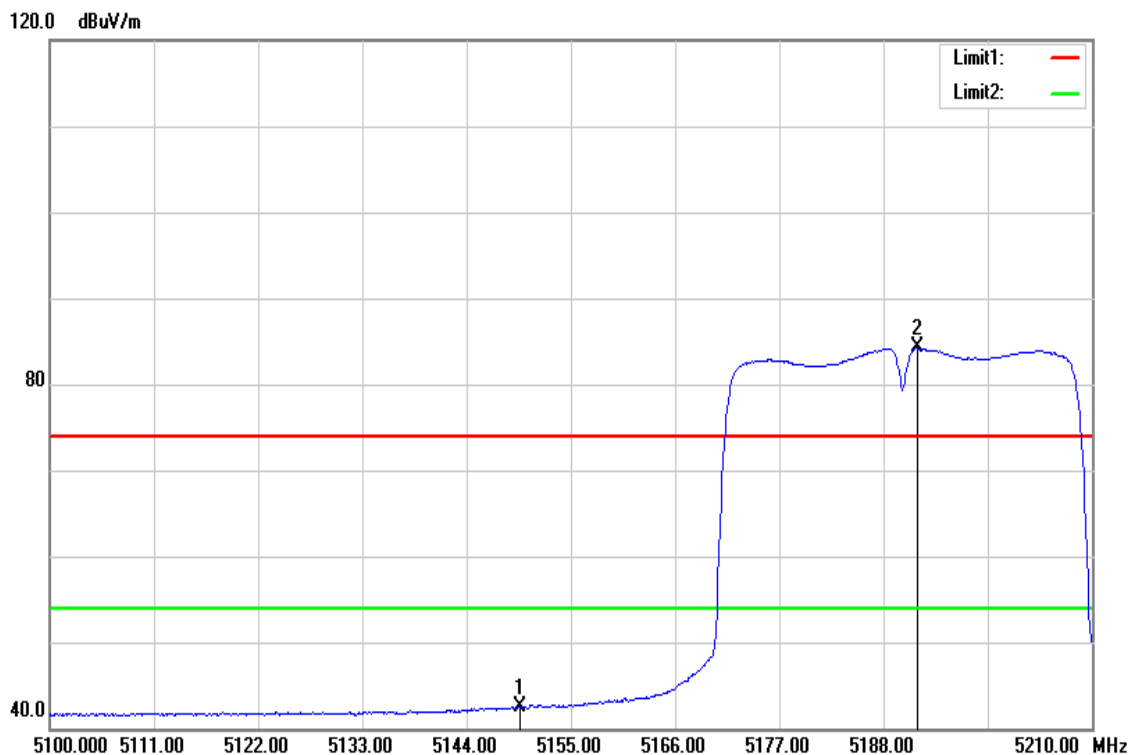

Frequency (MHz)	Reading (dBuV)	Correct Factor (dB/m)	Result (dBuV/m)	Limit (dBuV/m)	Margin (dB)	Remark
5149.610	37.44	5.06	42.50	54.00	-11.50	AVG
5191.520	79.06	5.16	84.22	-	-	AVG

Test Mode	IEEE 802.11n HT40 High CH	Temp/Hum	24(°C)/ 33%RH
Test Item	Band Edge	Test Date	December 1, 2017
Polarize	Vertical	Test Engineer	Kevin Kuo
Detector	Peak		

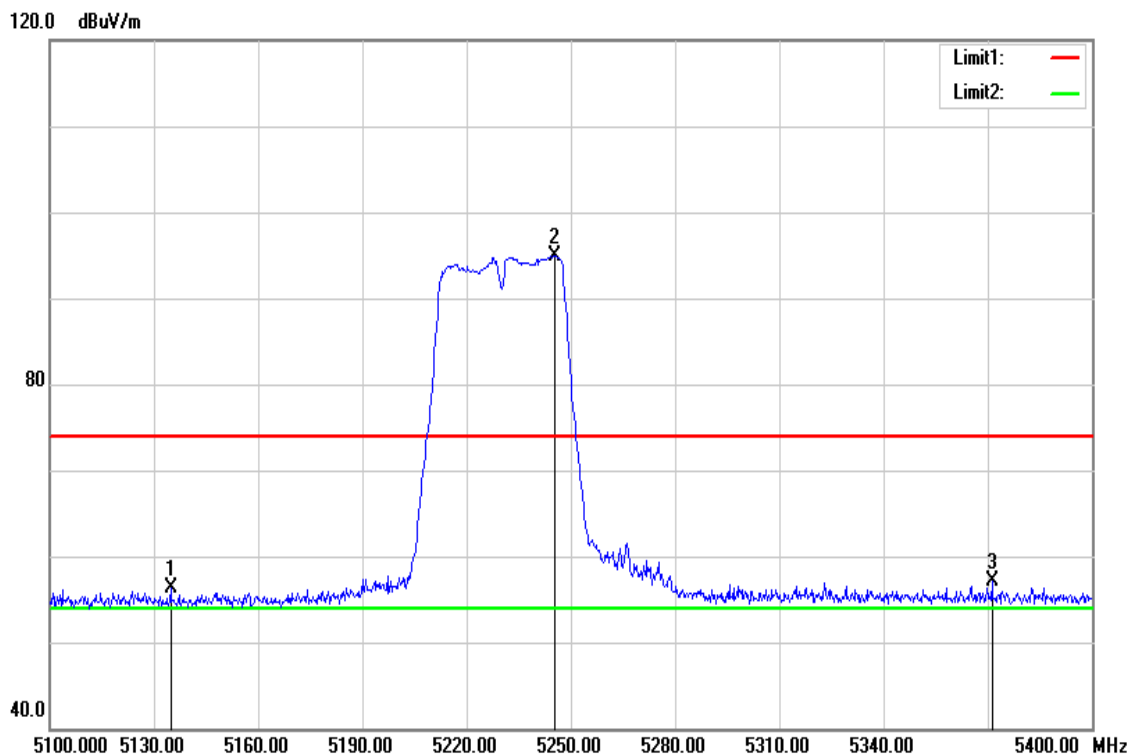

Frequency (MHz)	Reading (dBuV)	Correct Factor (dB/m)	Result (dBuV/m)	Limit (dBuV/m)	Margin (dB)	Remark
5134.800	51.22	5.02	56.24	74.00	-17.76	peak
5245.200	89.66	5.31	94.97	-	-	peak
5371.200	51.49	5.61	57.10	74.00	-16.90	peak

Test Mode	IEEE 802.11n HT40 High CH	Temperature	24(°C)/ 33%RH
Test Item	Band Edge	Test Date	December 1, 2017
Polarize	Vertical	Test Engineer	Kevin Kuo
Detector	Average		

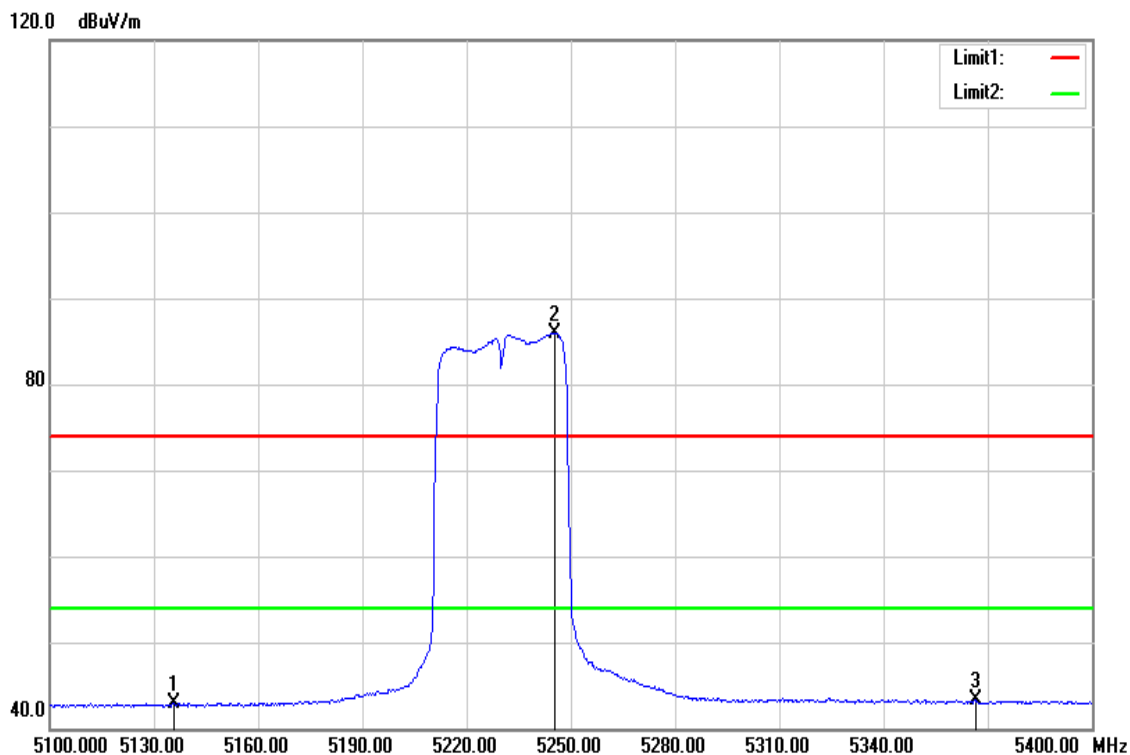

Frequency (MHz)	Reading (dBuV)	Correct Factor (dB/m)	Result (dBuV/m)	Limit (dBuV/m)	Margin (dB)	Remark
5135.700	37.91	5.03	42.94	54.00	-11.06	AVG
5245.200	80.66	5.31	85.97	-	-	AVG
5366.400	37.73	5.60	43.33	54.00	-10.67	AVG

Test Data

Band Edge Test Data for UNII-2a

Test Mode	IEEE 802.11a Low CH	Temp/Hum	24(°C)/ 33%RH
Test Item	Band Edge	Test Date	December 1, 2017
Polarize	Vertical	Test Engineer	Kevin Kuo
Detector	Peak		

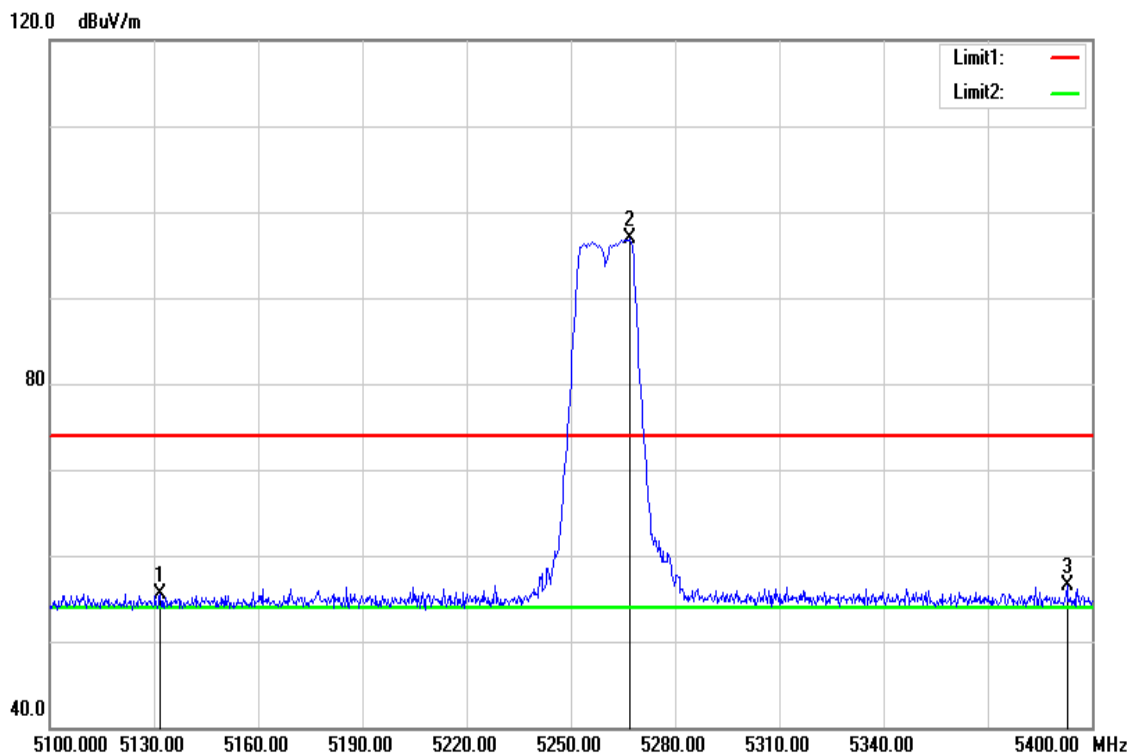

Frequency (MHz)	Reading (dBuV)	Correct Factor (dB/m)	Result (dBuV/m)	Limit (dBuV/m)	Margin (dB)	Remark
5131.800	50.39	5.02	55.41	74.00	-18.59	peak
5266.800	91.50	5.35	96.85	-	-	peak
5392.800	50.89	5.67	56.56	74.00	-17.44	peak

Test Mode	IEEE 802.11a Low CH	Temperature	24(°C)/ 33%RH
Test Item	Band Edge	Test Date	December 1, 2017
Polarize	Vertical	Test Engineer	Kevin Kuo
Detector	Average		

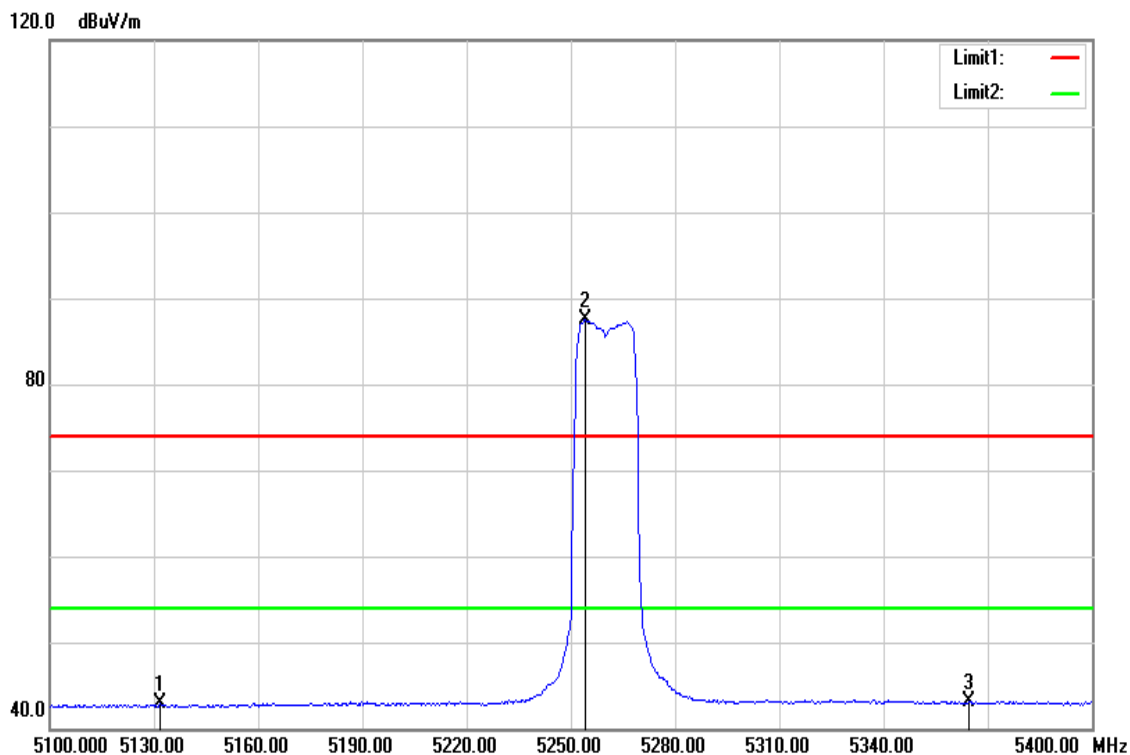

Frequency (MHz)	Reading (dBuV)	Correct Factor (dB/m)	Result (dBuV/m)	Limit (dBuV/m)	Margin (dB)	Remark
5131.800	37.82	5.02	42.84	54.00	-11.16	AVG
5254.200	82.14	5.31	87.45	-	-	AVG
5364.600	37.54	5.59	43.13	54.00	-10.87	AVG

Test Mode	IEEE 802.11a High CH	Temp/Hum	24(°C)/ 33%RH
Test Item	Band Edge	Test Date	December 1, 2017
Polarize	Vertical	Test Engineer	Kevin Kuo
Detector	Peak		

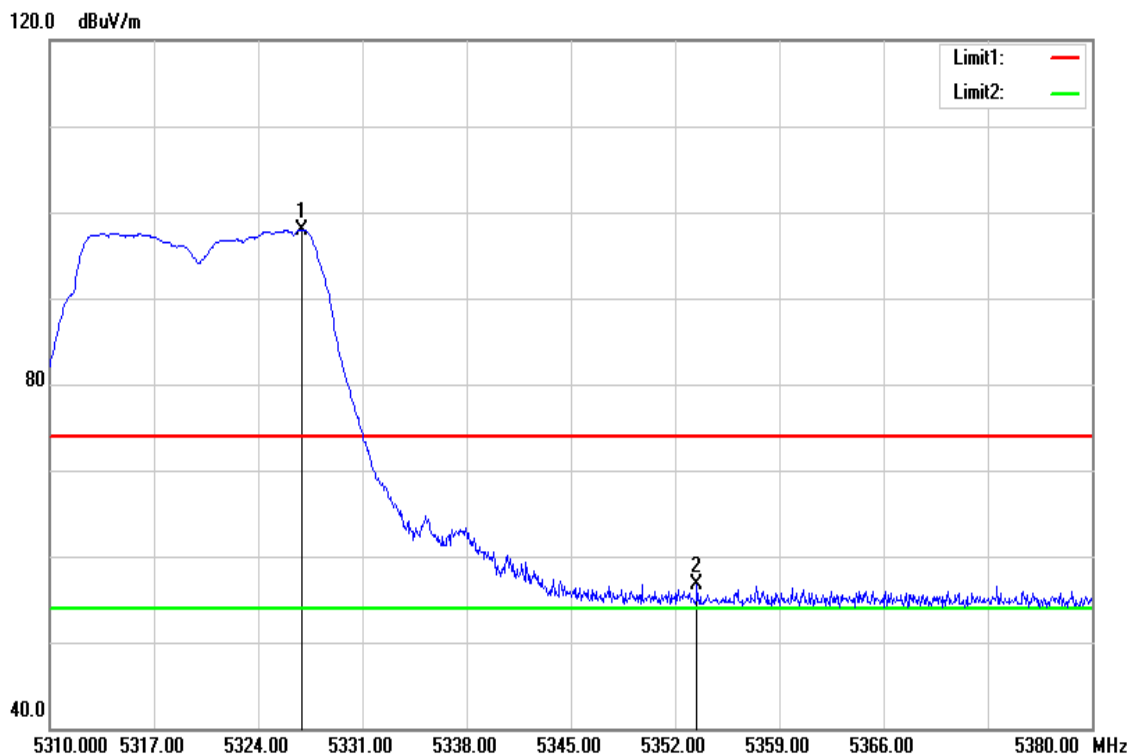

Frequency (MHz)	Reading (dBuV)	Correct Factor (dB/m)	Result (dBuV/m)	Limit (dBuV/m)	Margin (dB)	Remark
5326.940	92.43	5.51	97.94	-	-	peak
5353.470	51.16	5.56	56.72	74.00	-17.28	peak
N/A						

Test Mode	IEEE 802.11a High CH	Temperature	24(°C)/ 33%RH
Test Item	Band Edge	Test Date	December 1, 2017
Polarize	Vertical	Test Engineer	Kevin Kuo
Detector	Average		

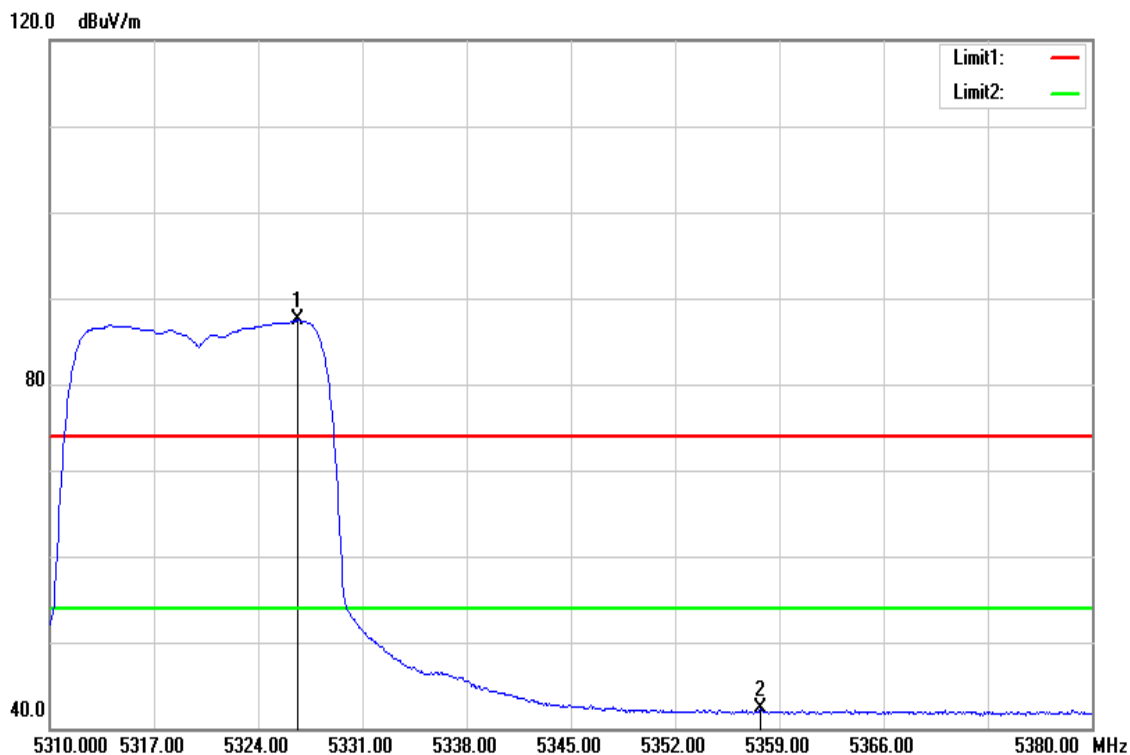

Frequency (MHz)	Reading (dBuV)	Correct Factor (dB/m)	Result (dBuV/m)	Limit (dBuV/m)	Margin (dB)	Remark
5326.660	81.92	5.51	87.43	-	-	AVG
5357.740	36.64	5.57	42.21	54.00	-11.79	AVG
N/A						

Test Mode	IEEE 802.11n HT20 Low CH	Temp/Hum	24(°C)/ 33%RH
Test Item	Band Edge	Test Date	December 1, 2017
Polarize	Vertical	Test Engineer	Kevin Kuo
Detector	Peak		

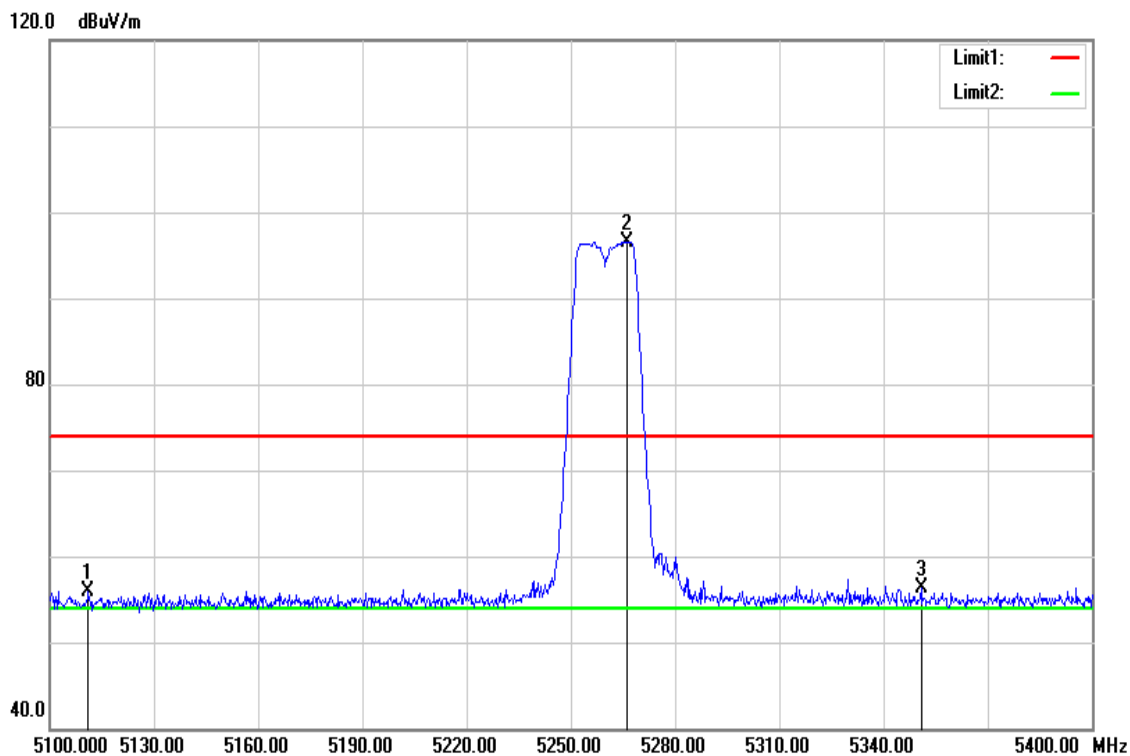

Frequency (MHz)	Reading (dBuV)	Correct Factor (dB/m)	Result (dBuV/m)	Limit (dBuV/m)	Margin (dB)	Remark
5111.100	50.93	4.97	55.90	74.00	-18.10	peak
5266.200	91.23	5.35	96.58	-	-	peak
5350.800	50.83	5.56	56.39	74.00	-17.61	peak

Test Mode	IEEE 802.11n HT20 Low CH	Temperature	24(°C)/ 33%RH
Test Item	Band Edge	Test Date	December 1, 2017
Polarize	Vertical	Test Engineer	Kevin Kuo
Detector	Average		

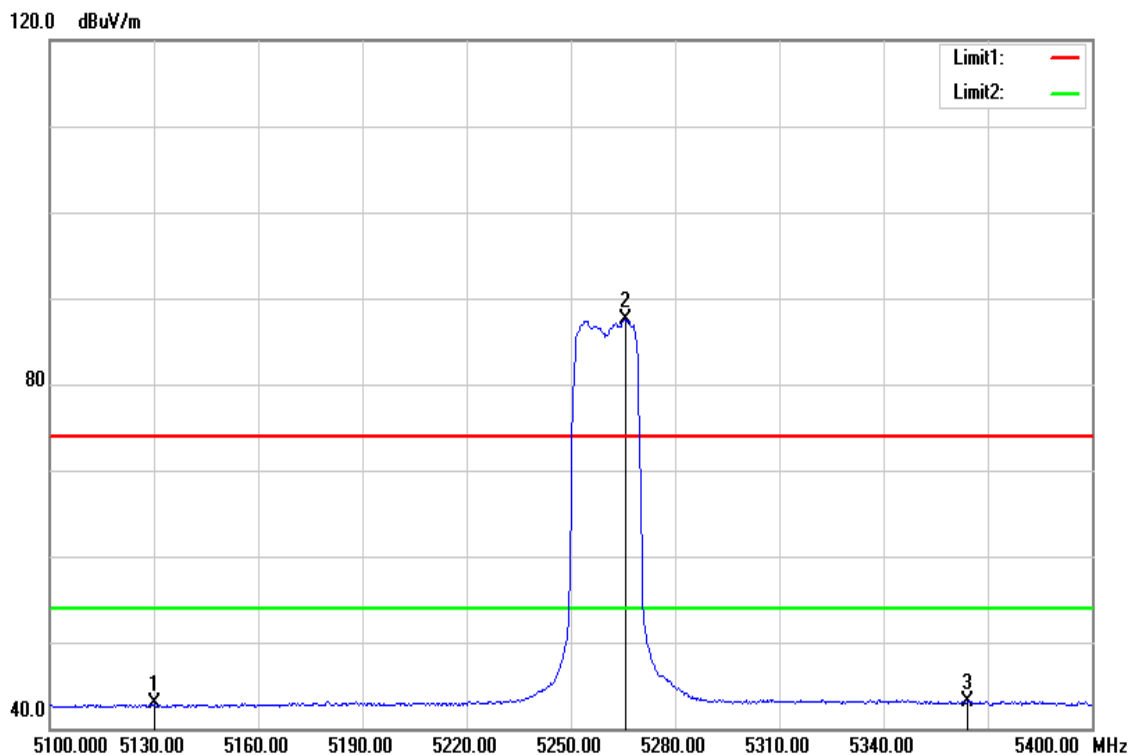

Frequency (MHz)	Reading (dBuV)	Correct Factor (dB/m)	Result (dBuV/m)	Limit (dBuV/m)	Margin (dB)	Remark
5130.300	37.82	5.01	42.83	54.00	-11.17	AVG
5265.900	82.08	5.35	87.43	-	-	AVG
5364.300	37.54	5.59	43.13	54.00	-10.87	AVG

Test Mode	IEEE 802.11n HT20 High CH	Temp/Hum	24(°C)/ 33%RH
Test Item	Band Edge	Test Date	December 1, 2017
Polarize	Vertical	Test Engineer	Kevin Kuo
Detector	Peak		

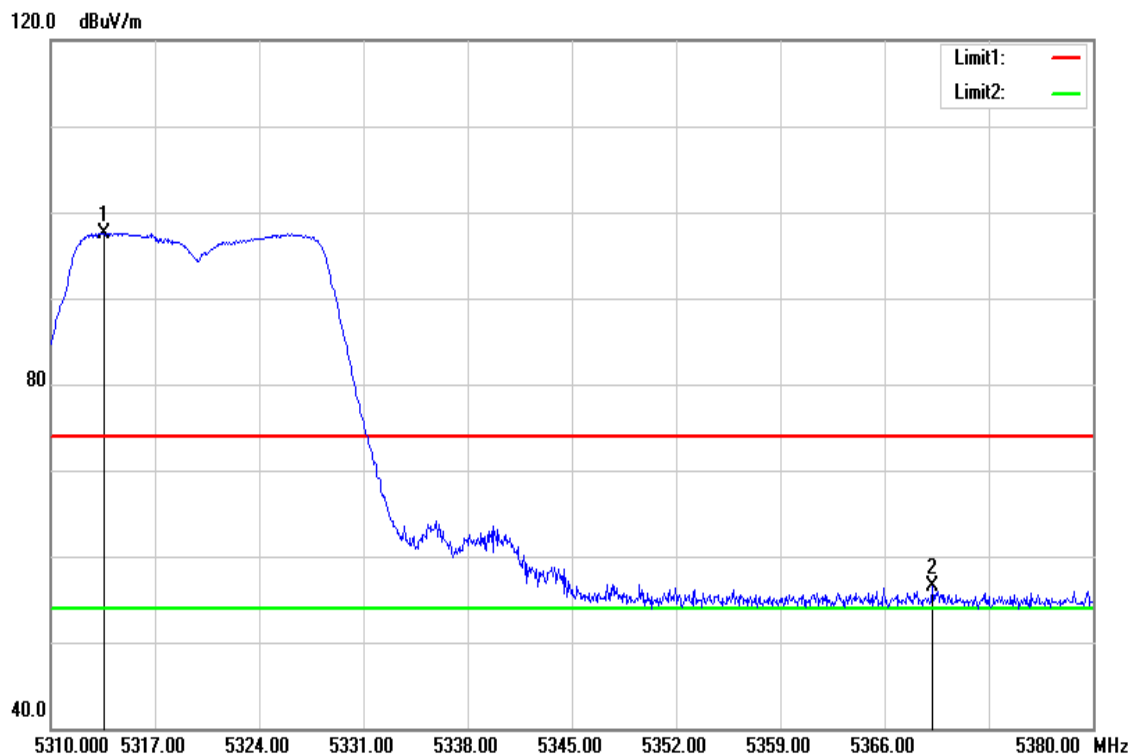

Frequency (MHz)	Reading (dBuV)	Correct Factor (dB/m)	Result (dBuV/m)	Limit (dBuV/m)	Margin (dB)	Remark
5313.570	92.10	5.47	97.57	-	-	peak
5369.220	50.89	5.60	56.49	74.00	-17.51	peak
N/A						

Test Mode	IEEE 802.11n HT20 High CH	Temperature	24(°C)/ 33%RH
Test Item	Band Edge	Test Date	December 1, 2017
Polarize	Vertical	Test Engineer	Kevin Kuo
Detector	Average		

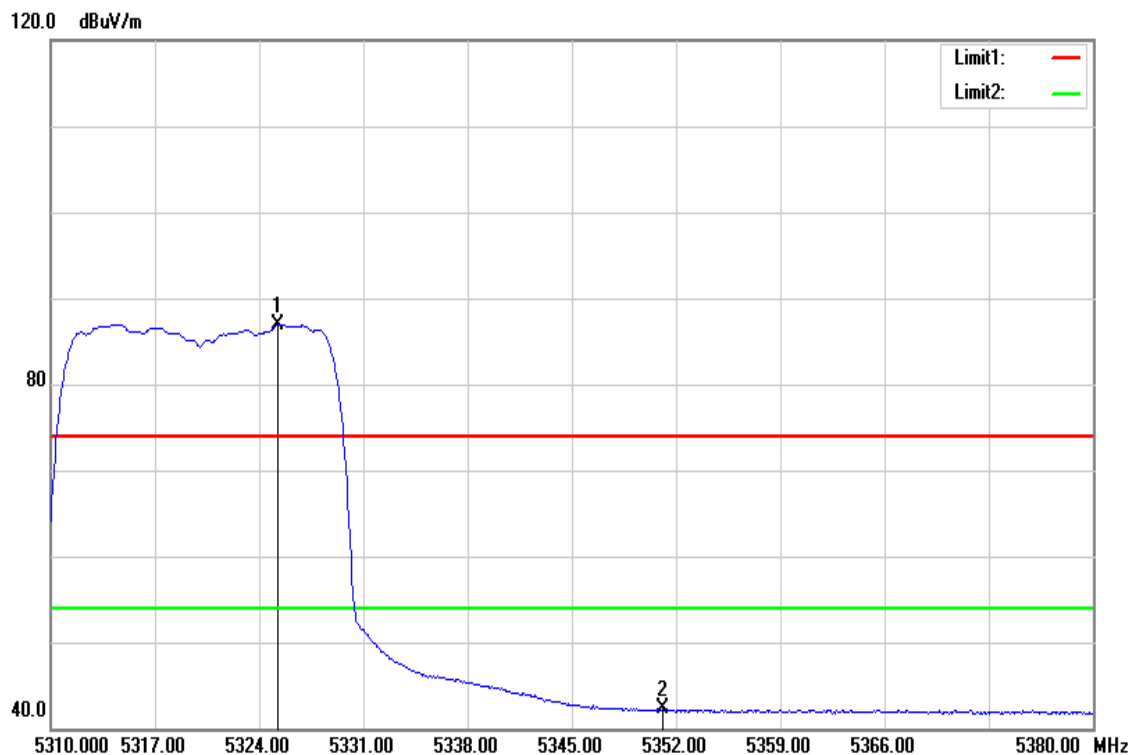

Frequency (MHz)	Reading (dBuV)	Correct Factor (dB/m)	Result (dBuV/m)	Limit (dBuV/m)	Margin (dB)	Remark
5325.260	81.46	5.51	86.97	-	-	AVG
5351.090	36.68	5.56	42.24	54.00	-11.76	AVG
N/A						

Test Mode	IEEE 802.11n HT40 Low CH	Temp/Hum	24(°C)/ 33%RH
Test Item	Band Edge	Test Date	December 1, 2017
Polarize	Vertical	Test Engineer	Kevin Kuo
Detector	Peak		

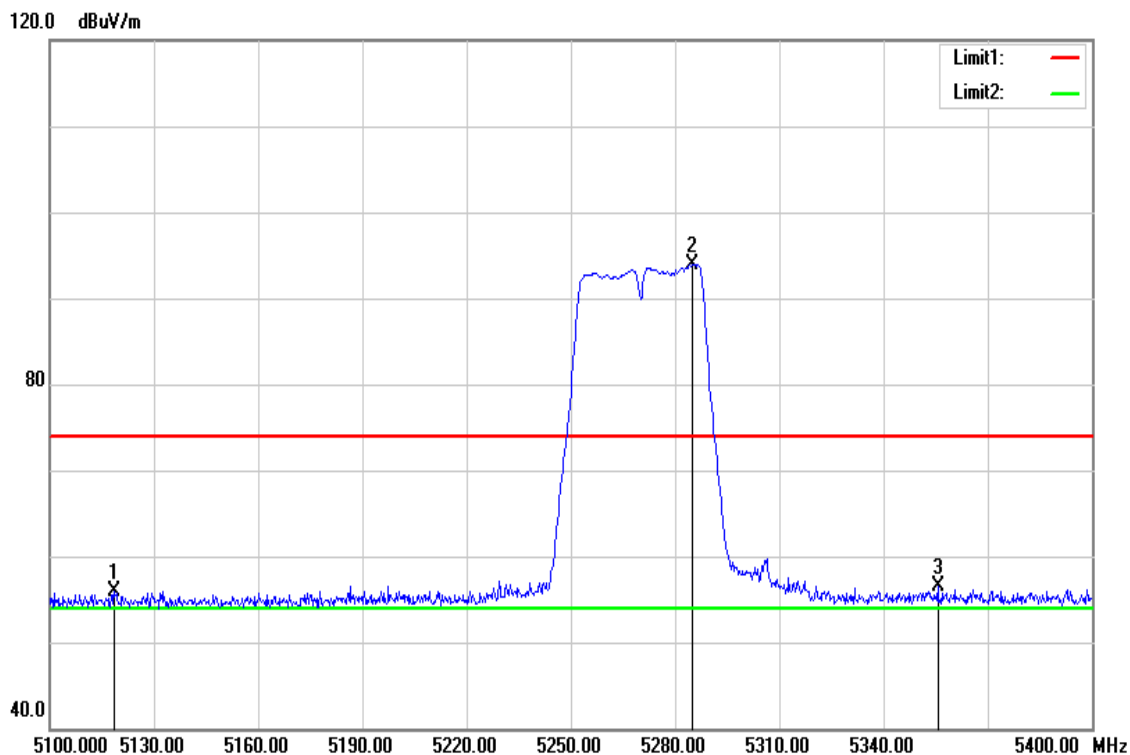

Frequency (MHz)	Reading (dBuV)	Correct Factor (dB/m)	Result (dBuV/m)	Limit (dBuV/m)	Margin (dB)	Remark
5118.600	50.91	4.98	55.89	74.00	-18.11	peak
5285.100	88.56	5.40	93.96	-	-	peak
5355.600	51.01	5.57	56.58	74.00	-17.42	peak

Test Mode	IEEE 802.11n HT40 Low CH	Temperature	24(°C)/ 33%RH
Test Item	Band Edge	Test Date	December 1, 2017
Polarize	Vertical	Test Engineer	Kevin Kuo
Detector	Average		

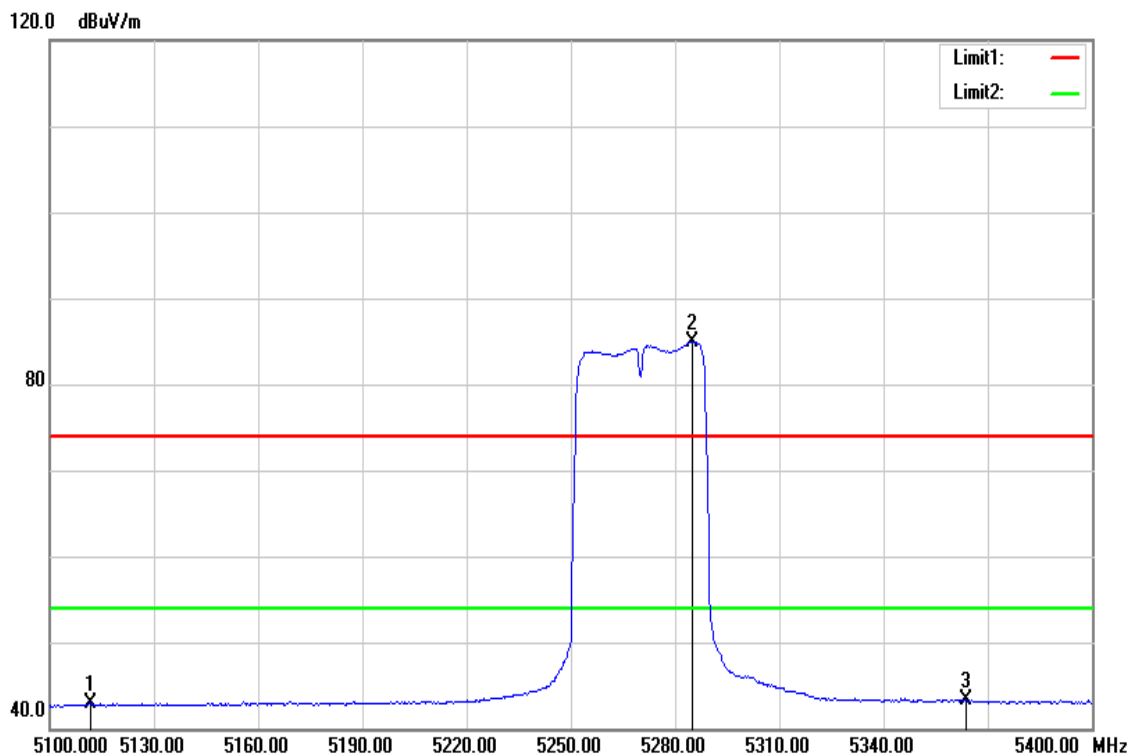

Frequency (MHz)	Reading (dBuV)	Correct Factor (dB/m)	Result (dBuV/m)	Limit (dBuV/m)	Margin (dB)	Remark
5111.700	37.94	4.97	42.91	54.00	-11.09	AVG
5285.100	79.56	5.40	84.96	-	-	AVG
5363.700	37.81	5.59	43.40	54.00	-10.60	AVG

Test Mode	IEEE 802.11n HT40 High CH	Temp/Hum	24(°C)/ 33%RH
Test Item	Band Edge	Test Date	December 1, 2017
Polarize	Vertical	Test Engineer	Kevin Kuo
Detector	Peak		

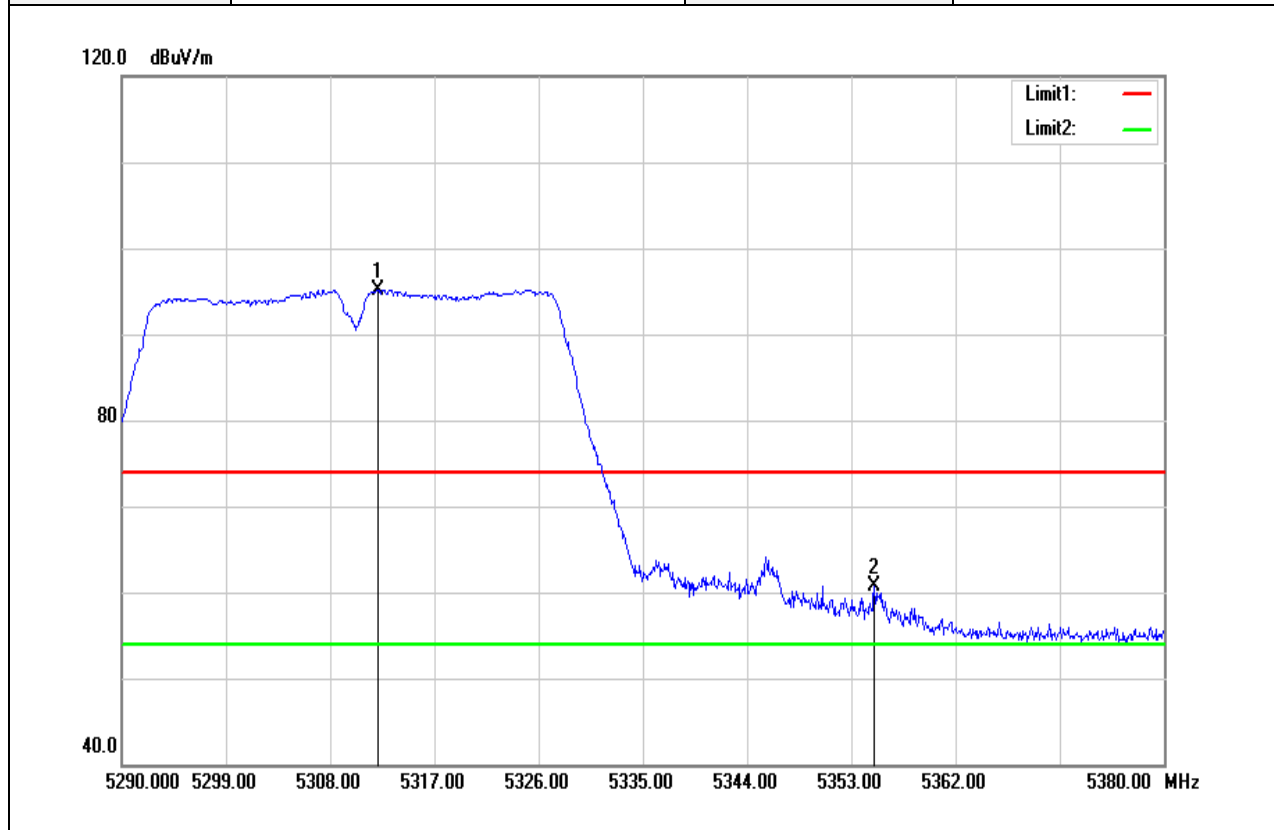

Frequency (MHz)	Reading (dBuV)	Correct Factor (dB/m)	Result (dBuV/m)	Limit (dBuV/m)	Margin (dB)	Remark
5312.140	89.70	5.46	95.16	-	-	peak
5354.980	55.20	5.56	60.76	74.00	-13.24	peak
N/A						

Test Mode	IEEE 802.11n HT40 High CH	Temperature	24(°C)/ 33%RH
Test Item	Band Edge	Test Date	December 1, 2017
Polarize	Vertical	Test Engineer	Kevin Kuo
Detector	Average		

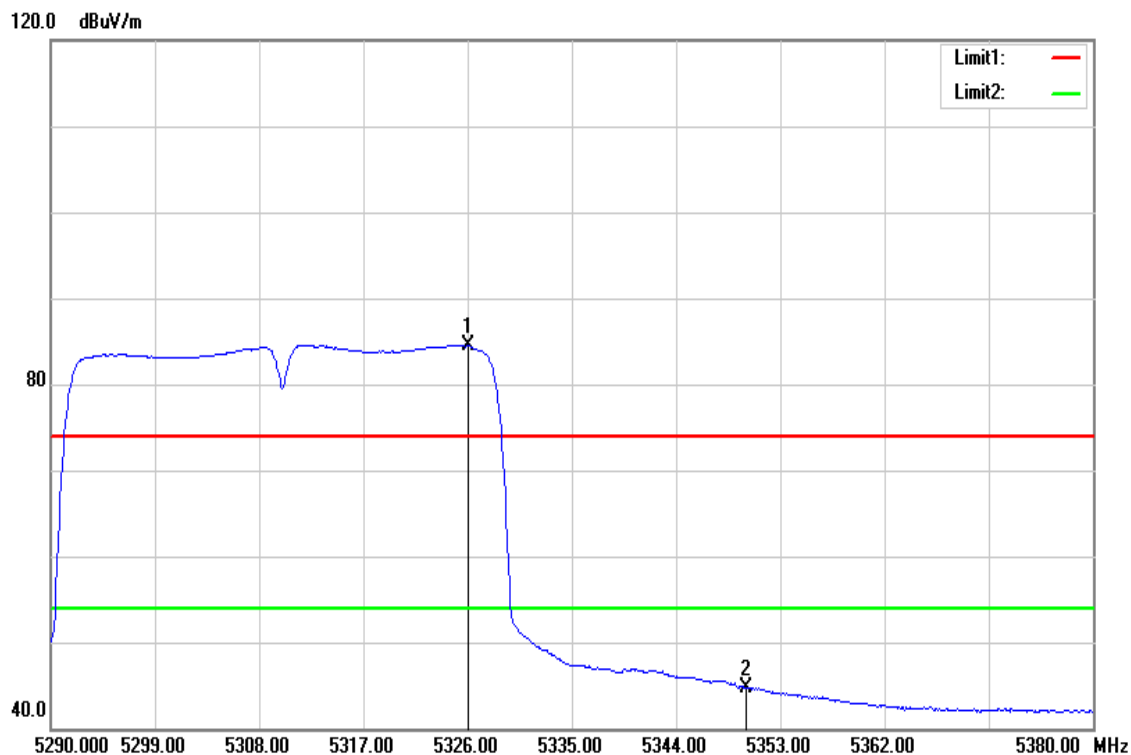

Frequency (MHz)	Reading (dBuV)	Correct Factor (dB/m)	Result (dBuV/m)	Limit (dBuV/m)	Margin (dB)	Remark
5326.000	79.00	5.51	84.51	-	-	AVG
5350.030	39.21	5.56	44.77	54.00	-9.23	AVG
N/A						

Test Data

Band Edge Test Data for UNII-2c

Test Mode	IEEE 802.11a Low CH	Temp/Hum	24(°C)/ 33%RH
Test Item	Band Edge	Test Date	December 1, 2017
Polarize	Vertical	Test Engineer	Kevin Kuo
Detector	Peak		

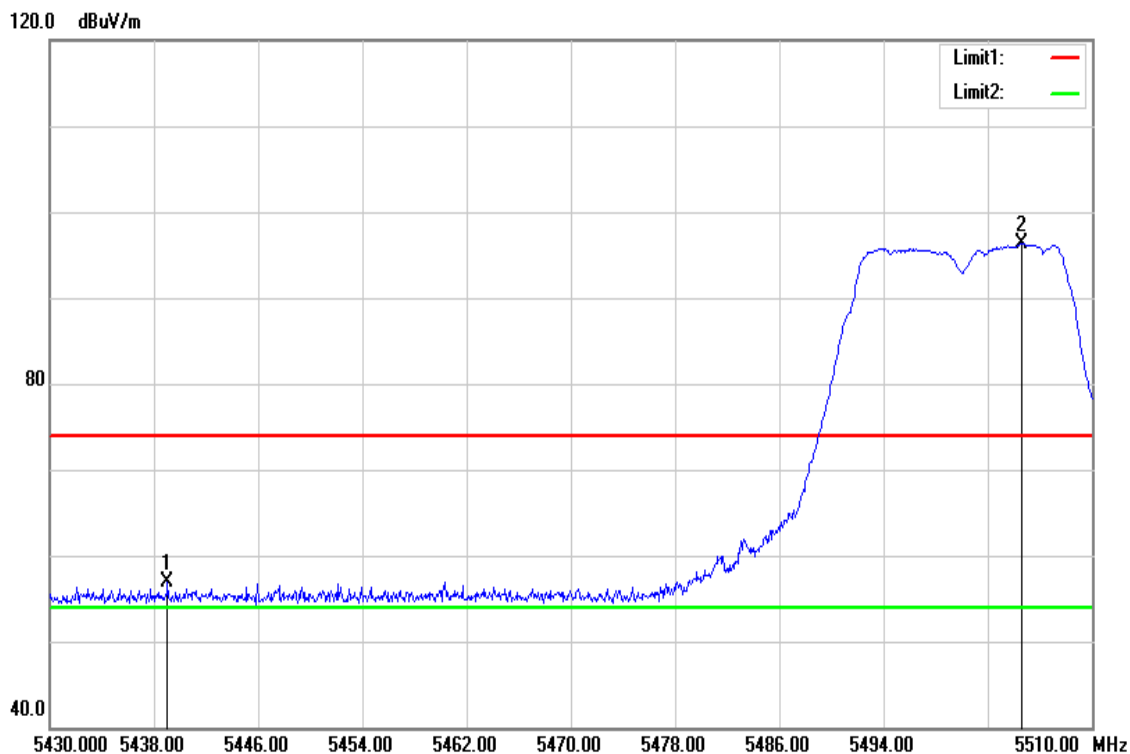

Frequency (MHz)	Reading (dBuV)	Correct Factor (dB/m)	Result (dBuV/m)	Limit (dBuV/m)	Margin (dB)	Remark
5439.040	51.16	5.78	56.94	74.00	-17.06	peak
5504.640	90.28	5.95	96.23	-	-	peak

Test Mode	IEEE 802.11a Low CH	Temperature	24(°C)/ 33%RH
Test Item	Band Edge	Test Date	December 1, 2017
Polarize	Vertical	Test Engineer	Kevin Kuo
Detector	Average		

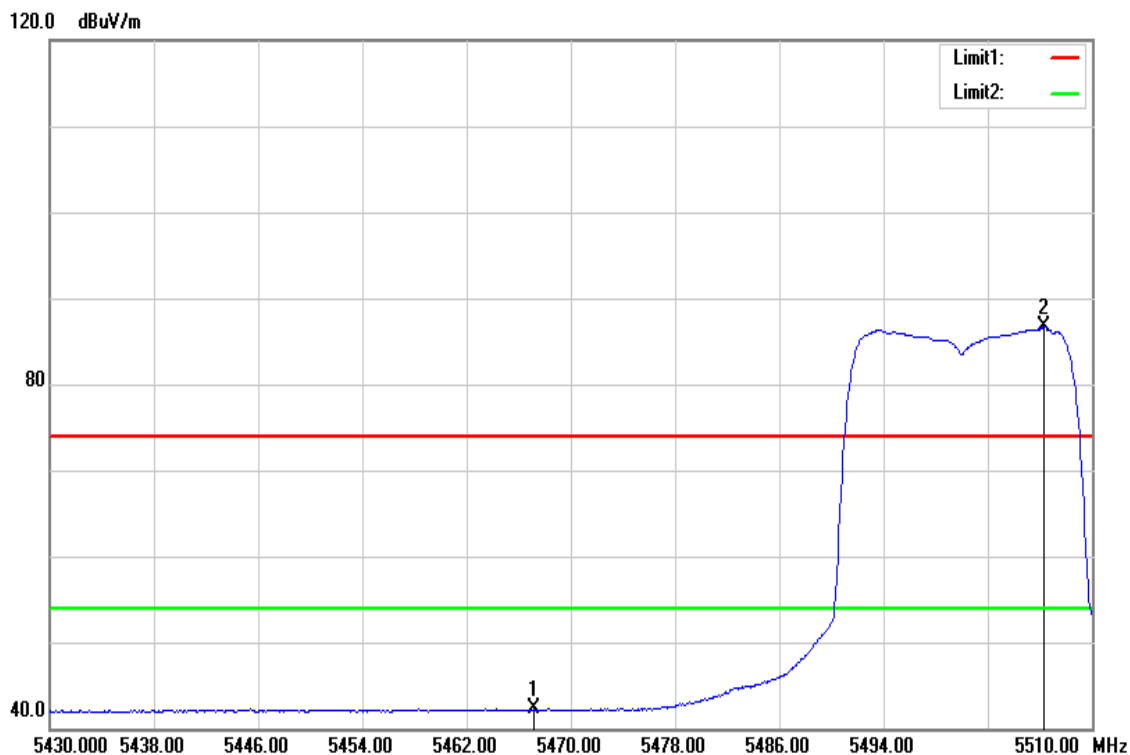

Frequency (MHz)	Reading (dBuV)	Correct Factor (dB/m)	Result (dBuV/m)	Limit (dBuV/m)	Margin (dB)	Remark
5467.120	36.41	5.85	42.26	54.00	-11.74	AVG
5506.320	80.70	5.95	86.65	-	-	AVG

Test Mode	IEEE 802.11a High CH	Temp/Hum	24(°C)/ 33%RH
Test Item	Band Edge	Test Date	December 1, 2017
Polarize	Vertical	Test Engineer	Kevin Kuo
Detector	Peak		

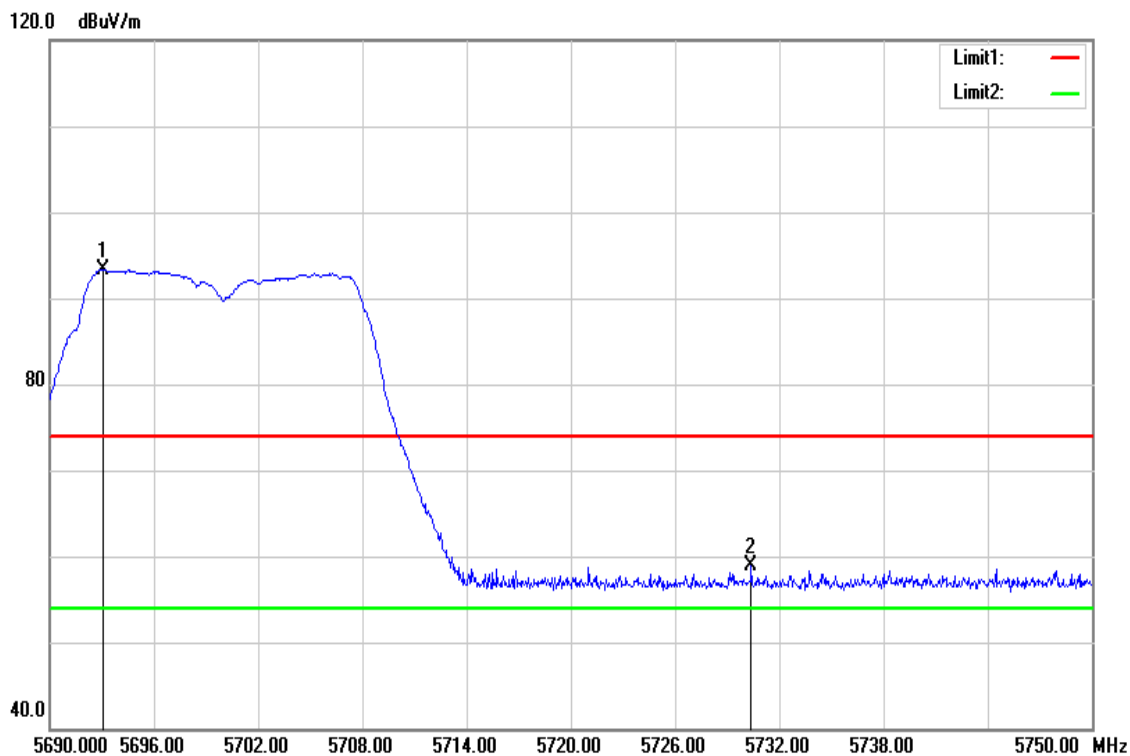

Frequency (MHz)	Reading (dBuV)	Correct Factor (dB/m)	Result (dBuV/m)	Limit (dBuV/m)	Margin (dB)	Remark
5693.060	86.88	6.44	93.32	-	-	peak
5730.380	52.29	6.54	58.83	74.00	-15.17	peak
N/A						

Test Mode	IEEE 802.11a High CH	Temperature	24(°C)/ 33%RH
Test Item	Band Edge	Test Date	December 1, 2017
Polarize	Vertical	Test Engineer	Kevin Kuo
Detector	Average		

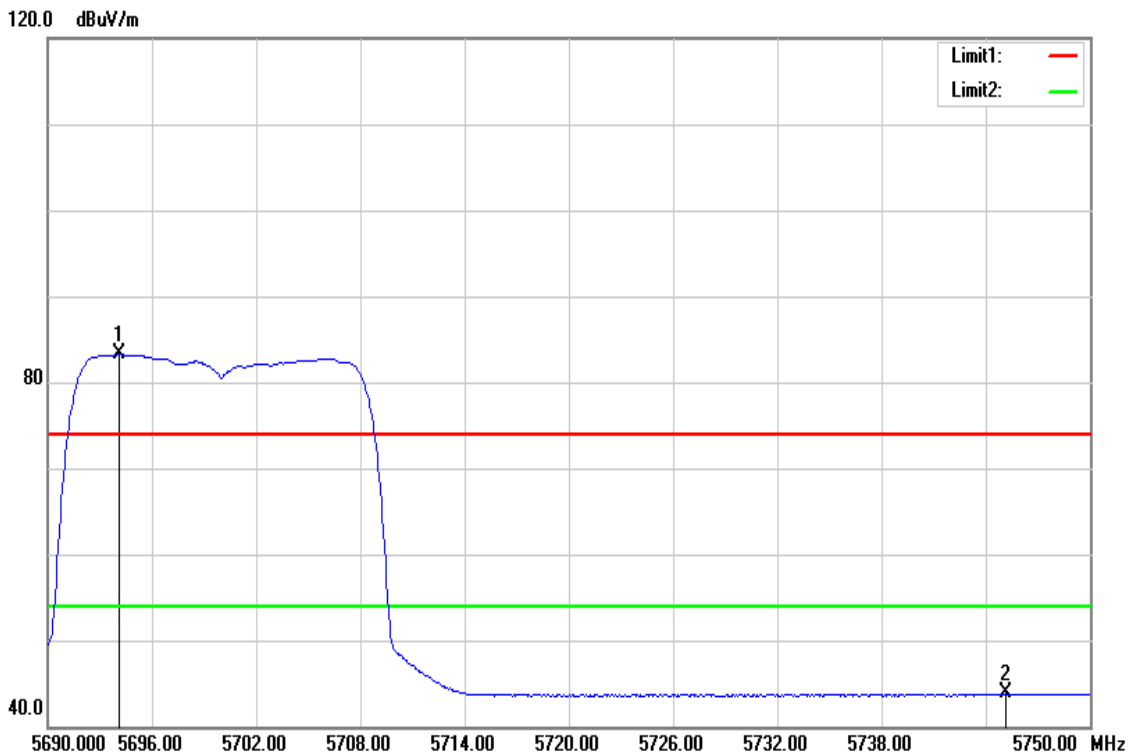

Frequency (MHz)	Reading (dBuV)	Correct Factor (dB/m)	Result (dBuV/m)	Limit (dBuV/m)	Margin (dB)	Remark
5694.140	76.89	6.44	83.33	-	-	AVG
5745.140	37.26	6.57	43.83	54.00	-10.17	AVG
N/A						

Test Mode	IEEE 802.11n HT20 Low CH	Temp/Hum	24(°C)/ 33%RH
Test Item	Band Edge	Test Date	December 1, 2017
Polarize	Vertical	Test Engineer	Kevin Kuo
Detector	Peak		

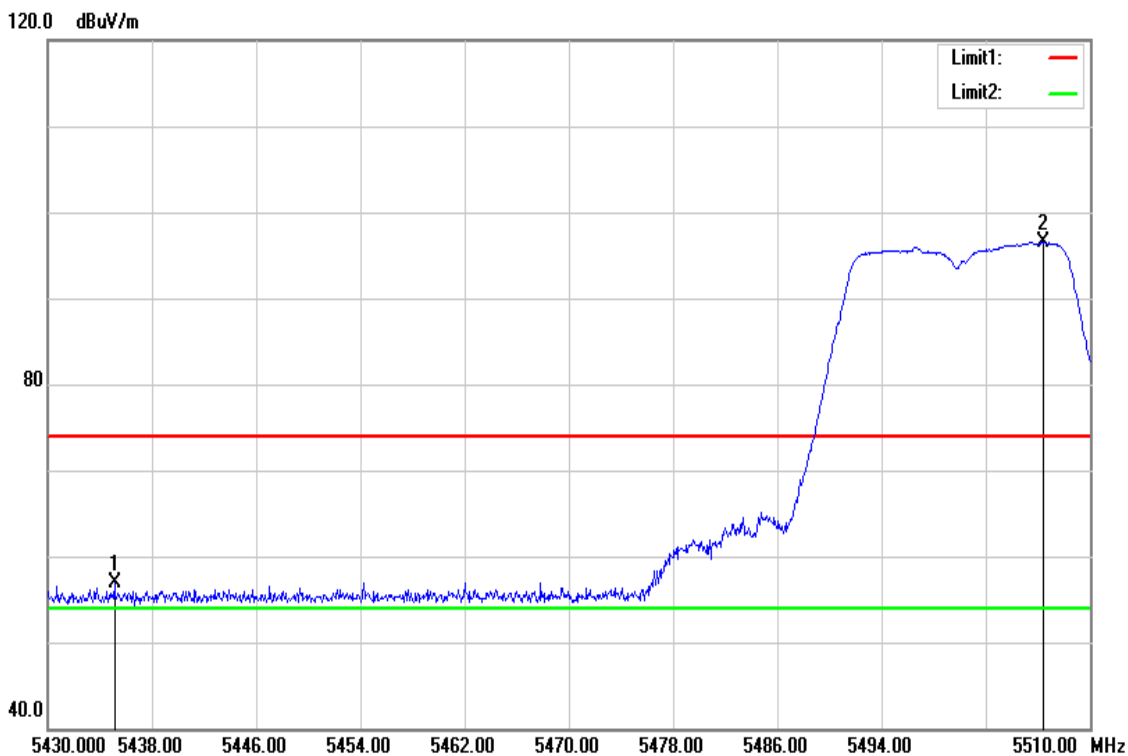

Frequency (MHz)	Reading (dBuV)	Correct Factor (dB/m)	Result (dBuV/m)	Limit (dBuV/m)	Margin (dB)	Remark
5435.120	51.20	5.77	56.97	74.00	-17.03	peak
5506.400	90.51	5.95	96.46	-	-	peak

Test Mode	IEEE 802.11n HT20 Low CH	Temperature	24(°C)/ 33%RH
Test Item	Band Edge	Test Date	December 1, 2017
Polarize	Vertical	Test Engineer	Kevin Kuo
Detector	Average		

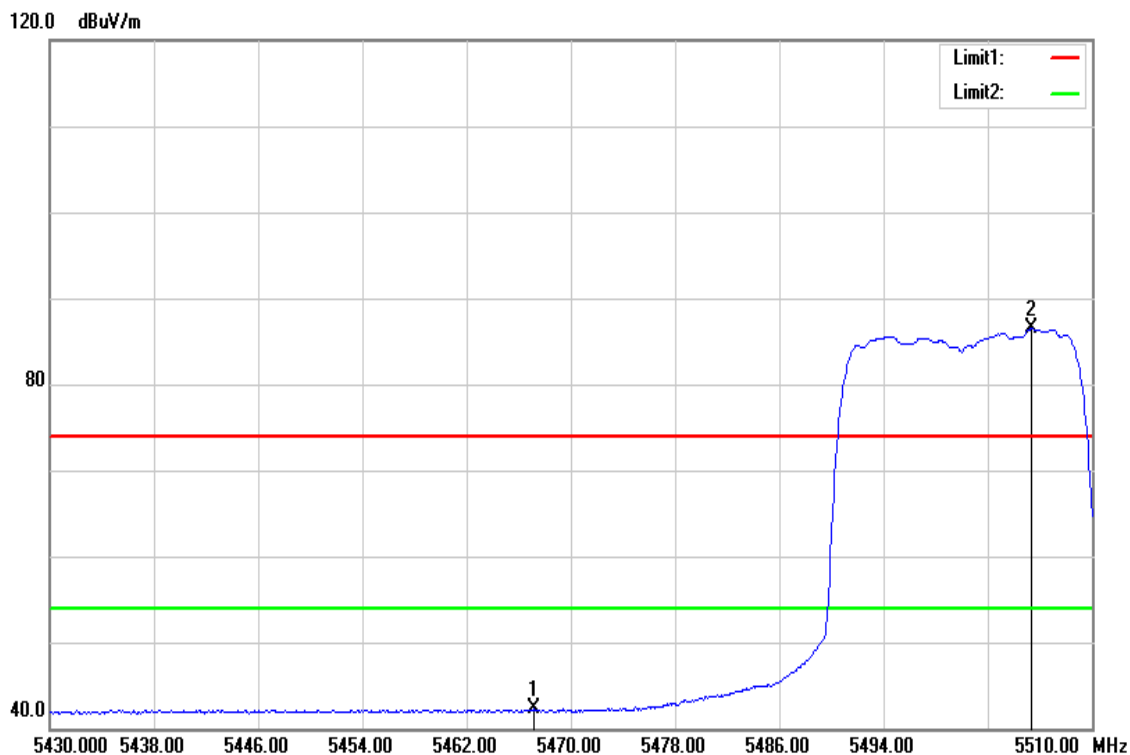

Frequency (MHz)	Reading (dBuV)	Correct Factor (dB/m)	Result (dBuV/m)	Limit (dBuV/m)	Margin (dB)	Remark
5467.120	36.40	5.85	42.25	54.00	-11.75	AVG
5505.360	80.50	5.95	86.45	-	-	AVG

Test Mode	IEEE 802.11n HT20 High CH	Temp/Hum	24(°C)/ 33%RH
Test Item	Band Edge	Test Date	December 1, 2017
Polarize	Vertical	Test Engineer	Kevin Kuo
Detector	Peak		

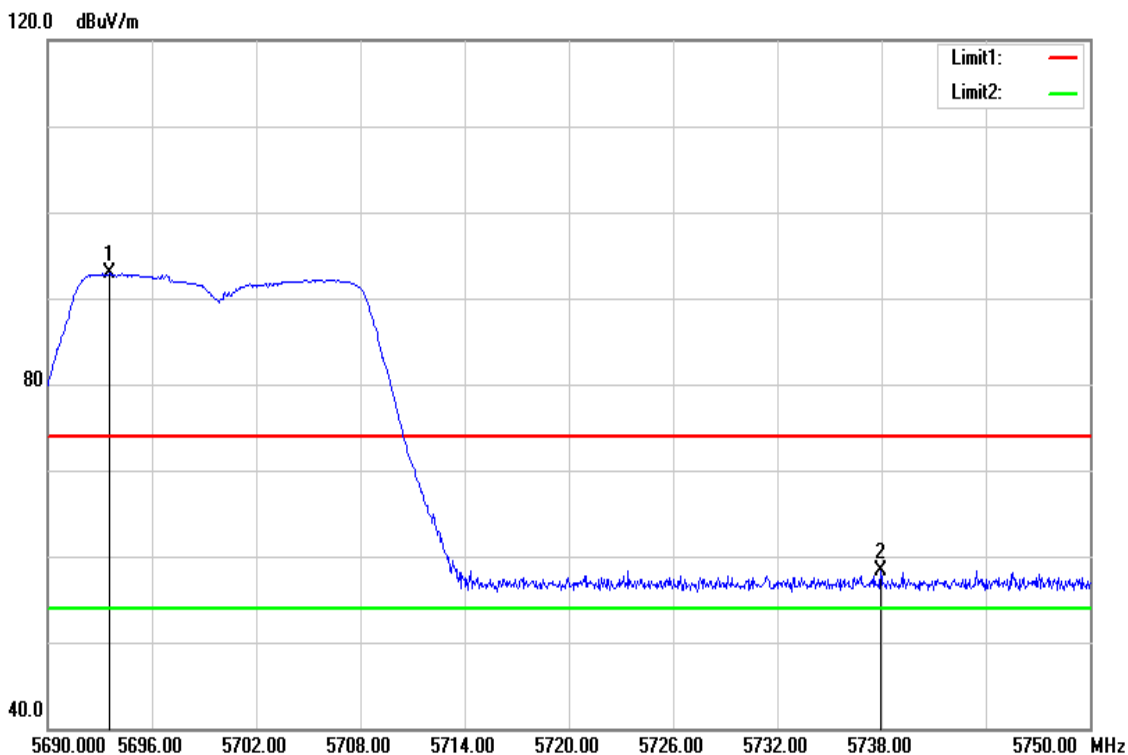

Frequency (MHz)	Reading (dBuV)	Correct Factor (dB/m)	Result (dBuV/m)	Limit (dBuV/m)	Margin (dB)	Remark
5693.540	86.43	6.44	92.87	-	-	peak
5737.940	51.79	6.56	58.35	74.00	-15.65	peak
N/A						

Test Mode	IEEE 802.11n HT20 High CH	Temperature	24(°C)/ 33%RH
Test Item	Band Edge	Test Date	December 1, 2017
Polarize	Vertical	Test Engineer	Kevin Kuo
Detector	Average		

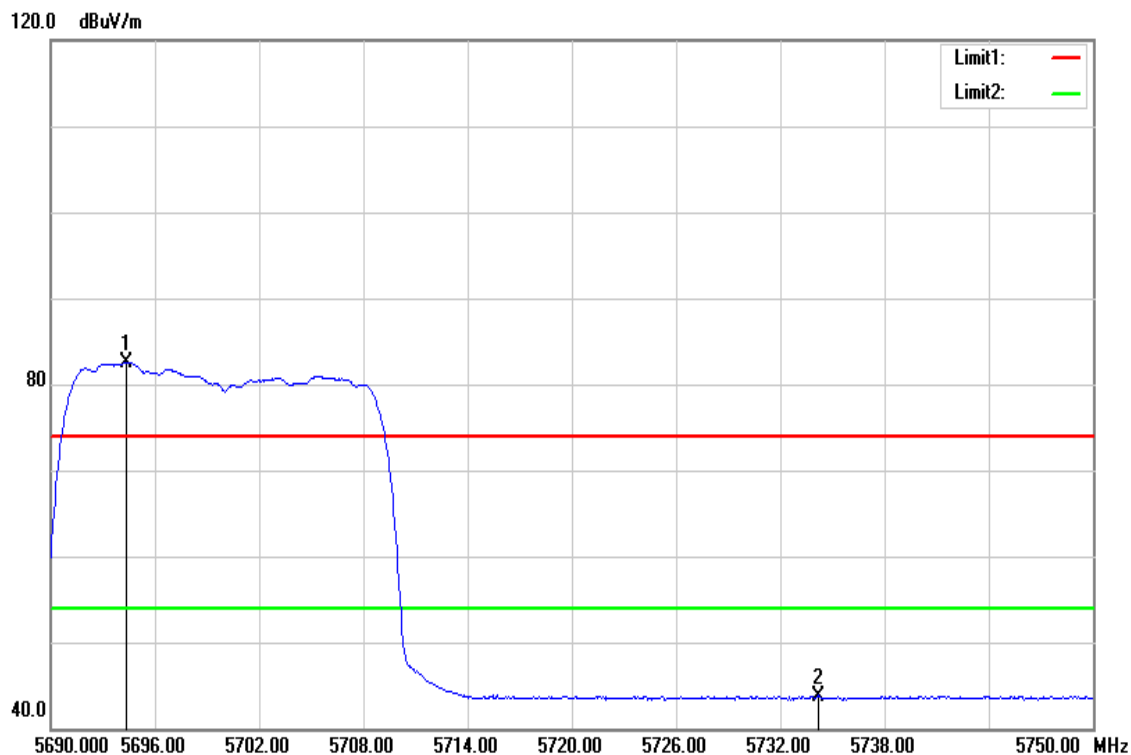

Frequency (MHz)	Reading (dBuV)	Correct Factor (dB/m)	Result (dBuV/m)	Limit (dBuV/m)	Margin (dB)	Remark
5694.320	76.03	6.44	82.47	-	-	AVG
5734.160	37.26	6.54	43.80	54.00	-10.20	AVG
N/A						

Test Mode	IEEE 802.11n HT40 Low CH	Temp/Hum	24(°C)/ 33%RH
Test Item	Band Edge	Test Date	December 1, 2017
Polarize	Vertical	Test Engineer	Kevin Kuo
Detector	Peak		

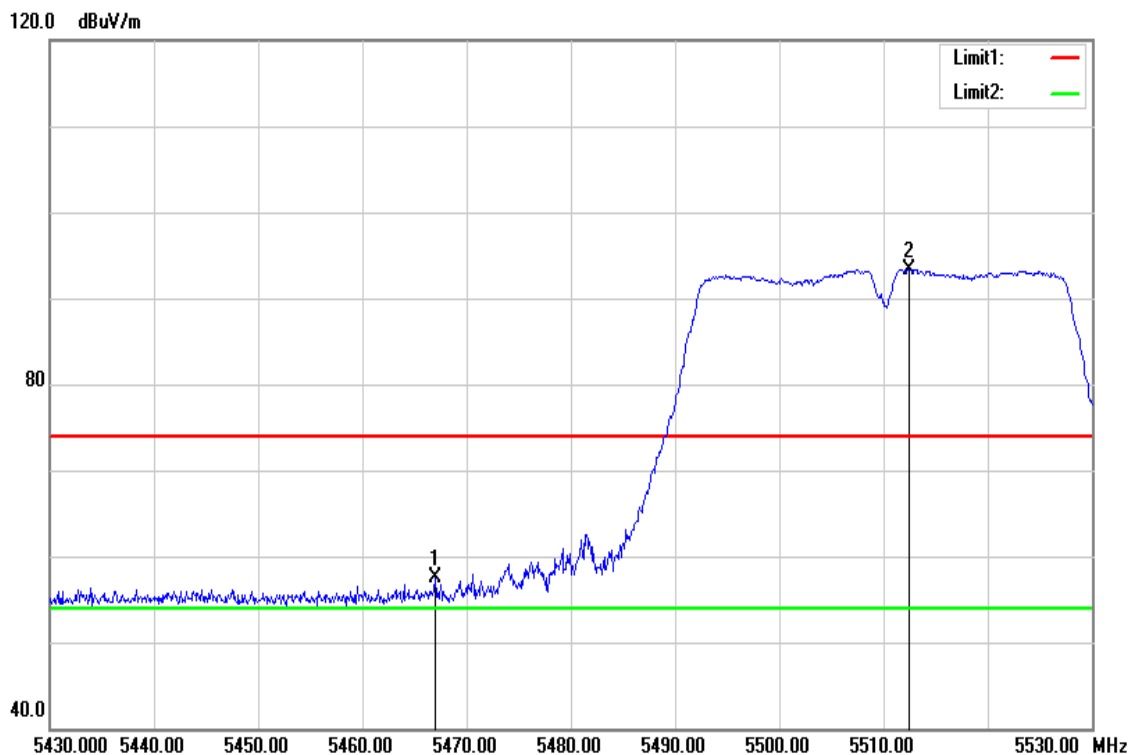

Frequency (MHz)	Reading (dBuV)	Correct Factor (dB/m)	Result (dBuV/m)	Limit (dBuV/m)	Margin (dB)	Remark
5467.000	51.60	5.85	57.45	74.00	-16.55	peak
5512.500	87.43	5.96	93.39	-	-	peak

Test Mode	IEEE 802.11n HT40 Low CH	Temperature	24(°C)/ 33%RH
Test Item	Band Edge	Test Date	December 1, 2017
Polarize	Vertical	Test Engineer	Kevin Kuo
Detector	Average		

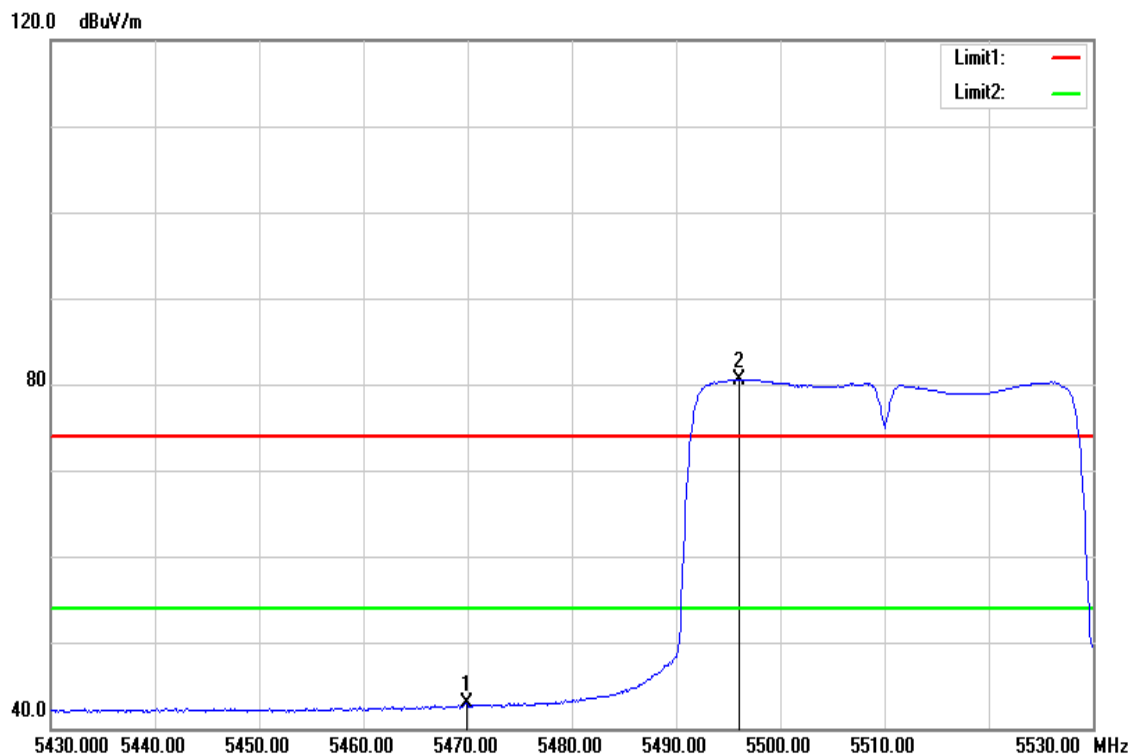

Frequency (MHz)	Reading (dBuV)	Correct Factor (dB/m)	Result (dBuV/m)	Limit (dBuV/m)	Margin (dB)	Remark
5469.900	36.96	5.85	42.81	54.00	-11.19	AVG
5496.000	74.62	5.93	80.55	-	-	AVG

Test Mode	IEEE 802.11n HT40 High CH	Temp/Hum	24(°C)/ 33%RH
Test Item	Band Edge	Test Date	December 1, 2017
Polarize	Vertical	Test Engineer	Kevin Kuo
Detector	Peak		

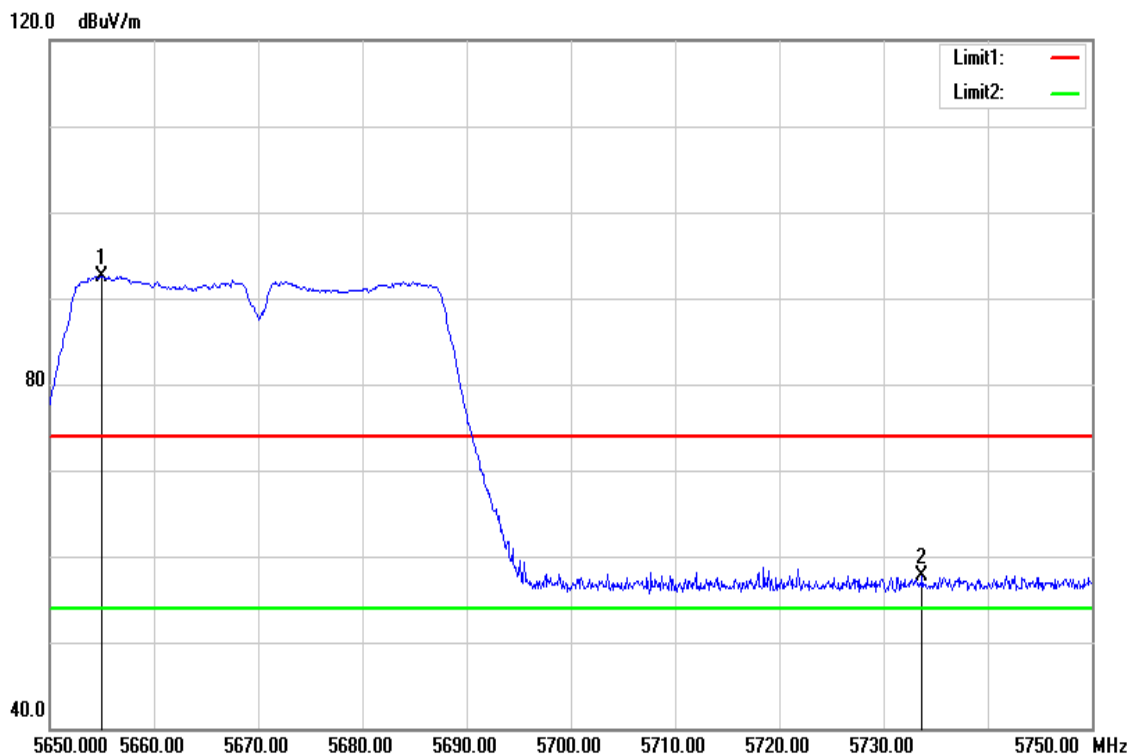

Frequency (MHz)	Reading (dBuV)	Correct Factor (dB/m)	Result (dBuV/m)	Limit (dBuV/m)	Margin (dB)	Remark
5655.000	86.20	6.34	92.54	-	-	peak
5733.700	51.25	6.54	57.79	74.00	-16.21	peak
N/A						

Test Mode	IEEE 802.11n HT40 High CH	Temperature	24(°C)/ 33%RH
Test Item	Band Edge	Test Date	December 1, 2017
Polarize	Vertical	Test Engineer	Kevin Kuo
Detector	Average		

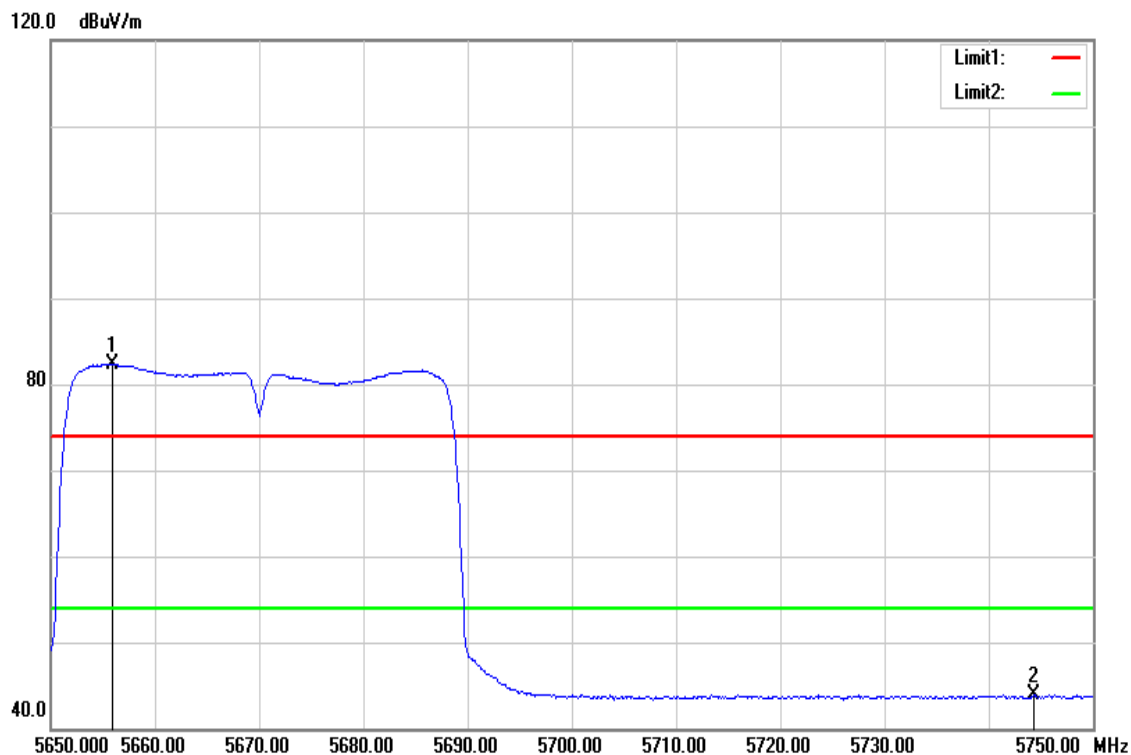

Frequency (MHz)	Reading (dBuV)	Correct Factor (dB/m)	Result (dBuV/m)	Limit (dBuV/m)	Margin (dB)	Remark
5655.900	75.96	6.34	82.30	-	-	AVG
5744.300	37.27	6.57	43.84	54.00	-10.16	AVG
N/A						

Band Edge Test Data for UNII-3

Test Mode	IEEE 802.11a Low CH	Temp/Hum	24(°C)/ 33%RH
Test Item	Band Edge	Test Date	December 1, 2017
Polarize	Vertical	Test Engineer	Kevin Kuo
Detector	Peak		

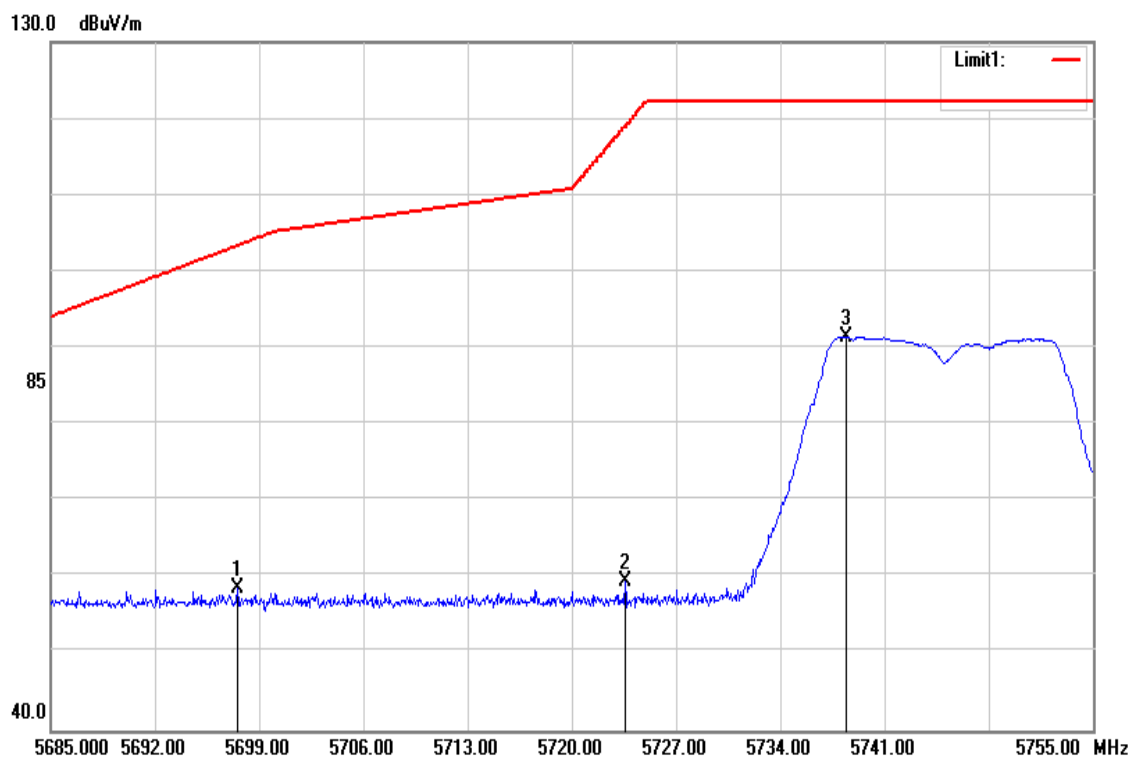

Frequency (MHz)	Reading (dBuV)	Correct Factor (dB/m)	Result (dBuV/m)	Limit (dBuV/m)	Margin (dB)	Remark
5697.530	52.10	6.46	58.56	103.37	-44.81	peak
5723.570	52.89	6.52	59.41	118.94	-59.53	peak
5738.410	84.95	6.56	91.51	-	-	peak

Test Mode	IEEE 802.11a Low CH	Temperature	24(°C)/ 33%RH
Test Item	Band Edge	Test Date	December 1, 2017
Polarize	Vertical	Test Engineer	Kevin Kuo
Detector	Average		

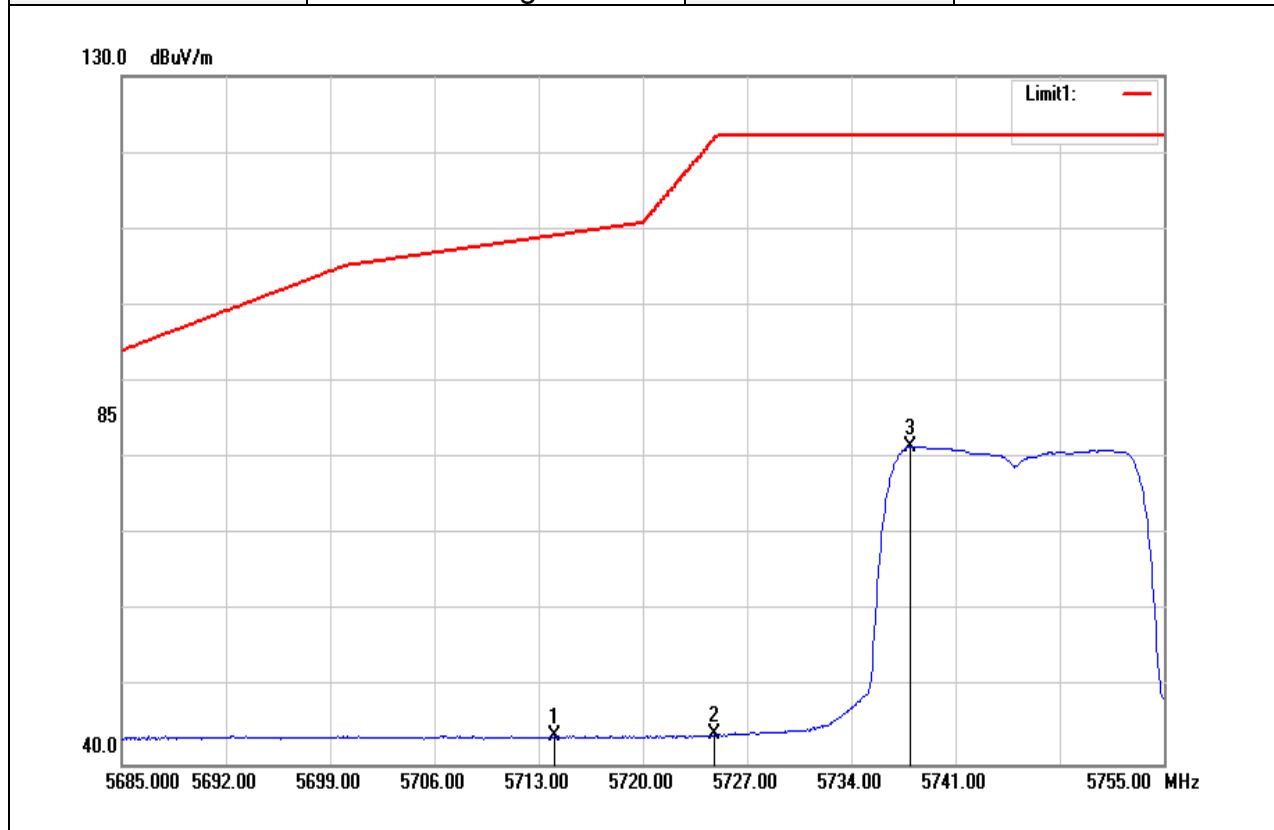

Frequency (MHz)	Reading (dBuV)	Correct Factor (dB/m)	Result (dBuV/m)	Limit (dBuV/m)	Margin (dB)	Remark
5714.050	37.23	6.50	43.73	109.13	-65.40	AVG
5724.760	37.32	6.52	43.84	121.65	-77.81	AVG
5737.990	75.03	6.56	81.59	-	-	AVG

Test Mode	IEEE 802.11a High CH	Temp/Hum	24(°C)/ 33%RH
Test Item	Band Edge	Test Date	December 1, 2017
Polarize	Vertical	Test Engineer	Kevin Kuo
Detector	Peak		

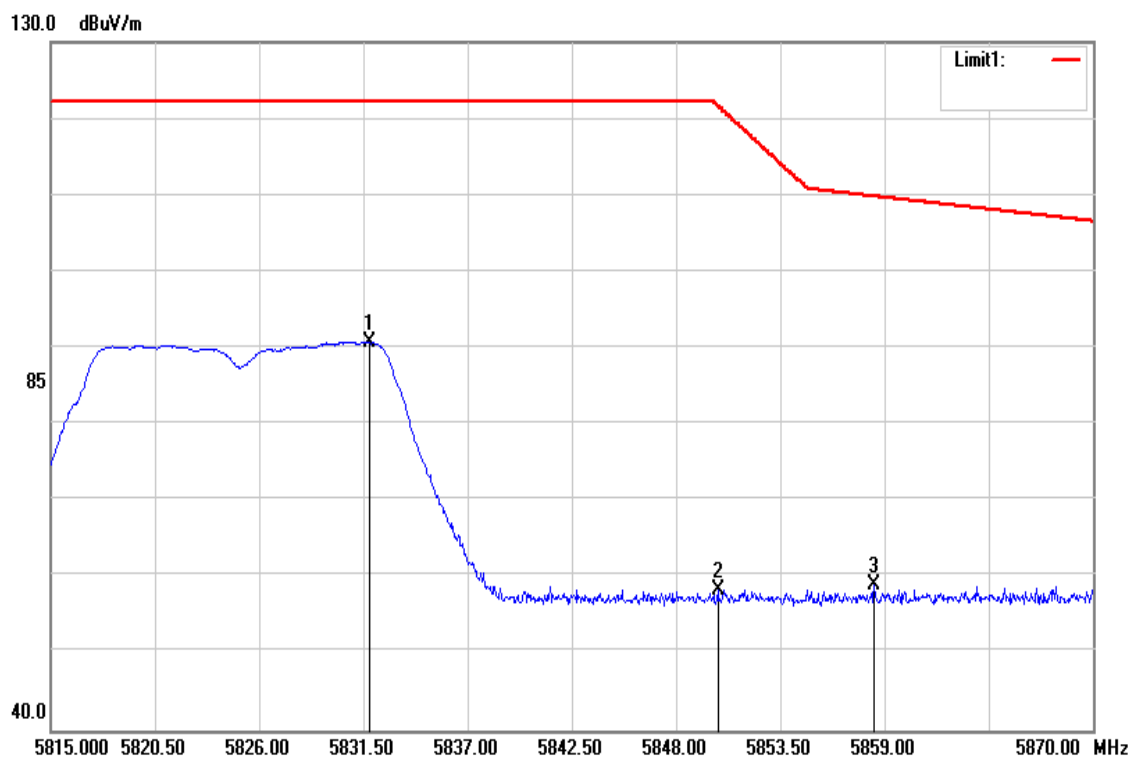

Frequency (MHz)	Reading (dBuV)	Correct Factor (dB/m)	Result (dBuV/m)	Limit (dBuV/m)	Margin (dB)	Remark
5831.830	84.00	6.80	90.80	-	-	peak
5850.200	51.54	6.85	58.39	121.74	-63.35	peak
5858.450	52.25	6.87	59.12	109.83	-50.71	peak

Test Mode	IEEE 802.11a High CH	Temperature	24(°C)/ 33%RH
Test Item	Band Edge	Test Date	December 1, 2017
Polarize	Vertical	Test Engineer	Kevin Kuo
Detector	Average		

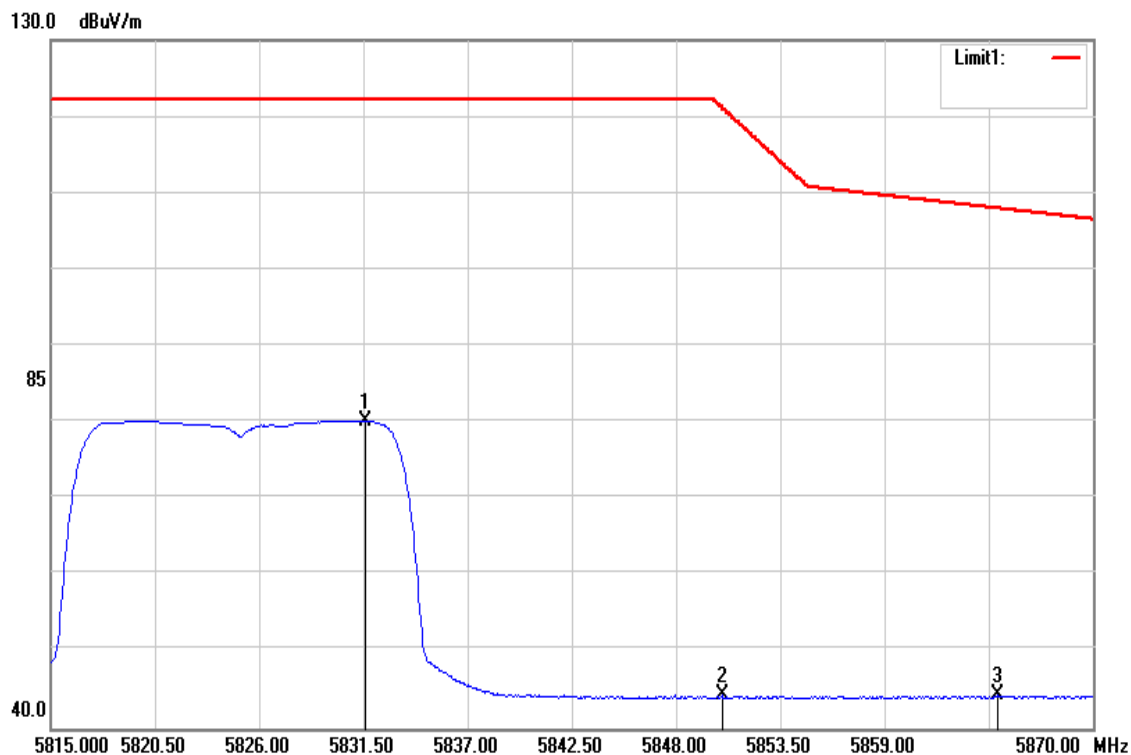

Frequency (MHz)	Reading (dBuV)	Correct Factor (dB/m)	Result (dBuV/m)	Limit (dBuV/m)	Margin (dB)	Remark
5831.610	73.45	6.80	80.25	-	-	AVG
5850.420	37.45	6.85	44.30	121.24	-76.94	AVG
5864.995	37.41	6.89	44.30	108.00	-63.70	AVG

Test Mode	IEEE 802.11n HT20 Low CH	Temp/Hum	24(°C)/ 33%RH
Test Item	Band Edge	Test Date	December 1, 2017
Polarize	Vertical	Test Engineer	Kevin Kuo
Detector	Peak		

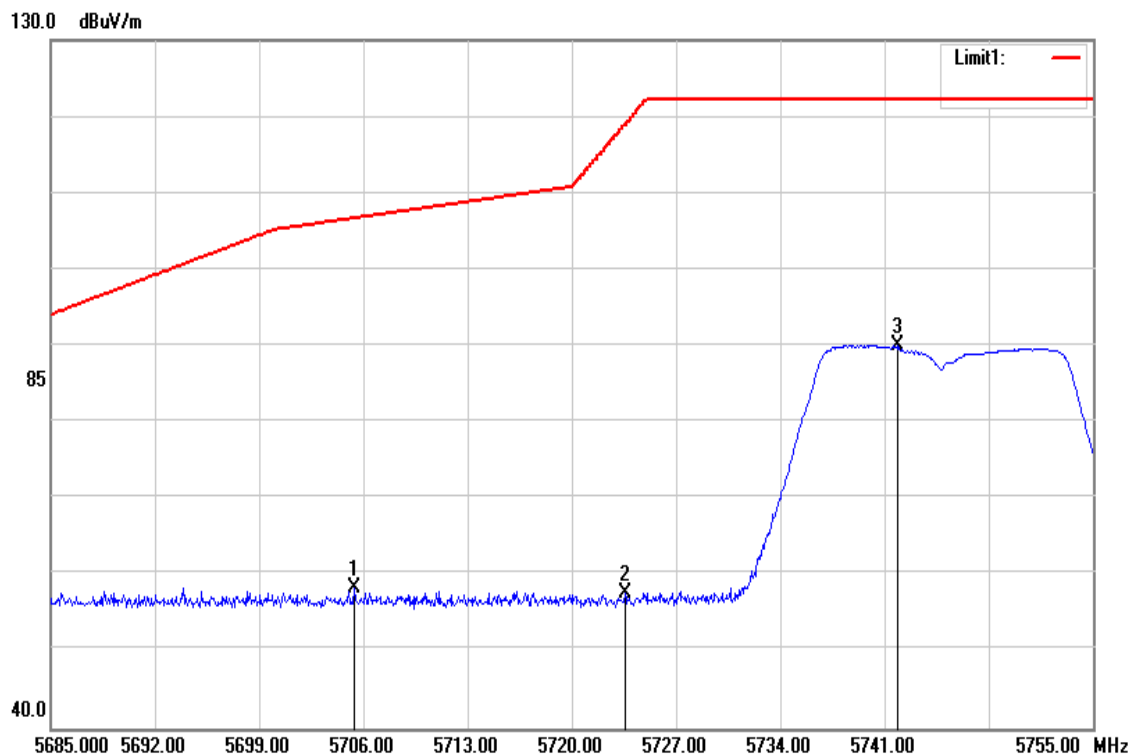

Frequency (MHz)	Reading (dBuV)	Correct Factor (dB/m)	Result (dBuV/m)	Limit (dBuV/m)	Margin (dB)	Remark
5705.370	51.93	6.47	58.40	106.70	-48.30	peak
5723.570	51.25	6.52	57.77	118.94	-61.17	peak
5741.840	83.54	6.56	90.10	-	-	peak

Test Mode	IEEE 802.11n HT20 Low CH	Temperature	24(°C)/ 33%RH
Test Item	Band Edge	Test Date	December 1, 2017
Polarize	Vertical	Test Engineer	Kevin Kuo
Detector	Average		

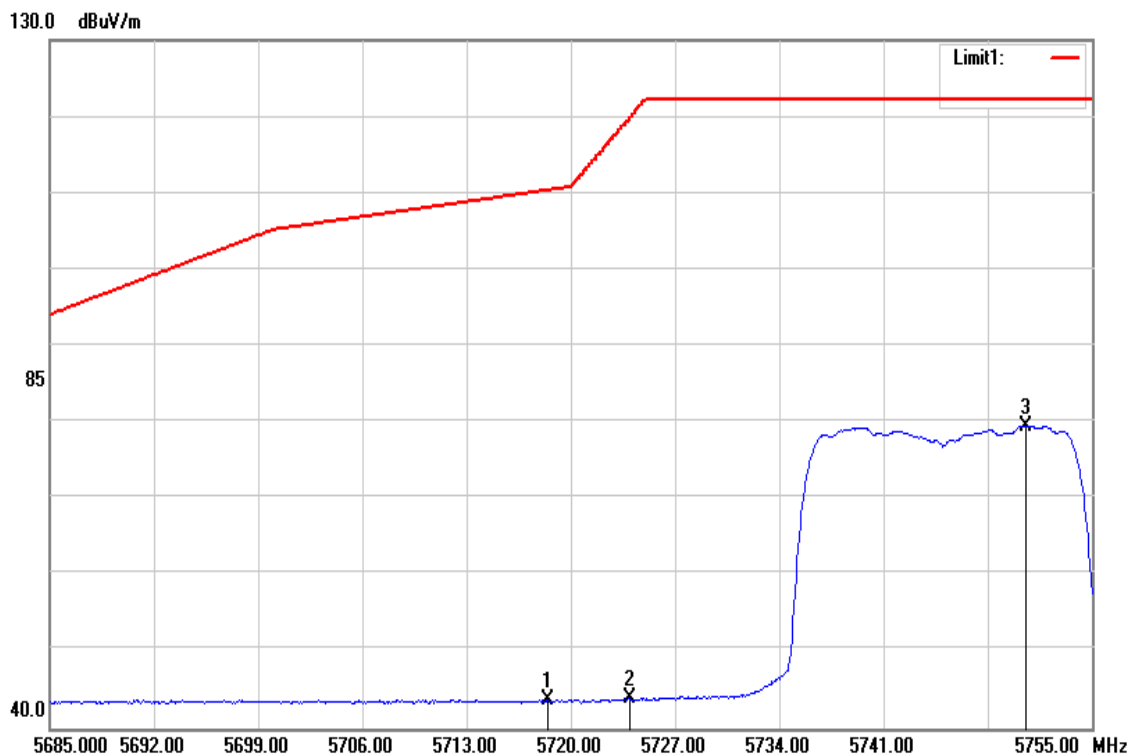

Frequency (MHz)	Reading (dBuV)	Correct Factor (dB/m)	Result (dBuV/m)	Limit (dBuV/m)	Margin (dB)	Remark
5718.460	37.21	6.50	43.71	110.37	-66.66	AVG
5723.920	37.35	6.52	43.87	119.74	-75.87	AVG
5750.520	73.00	6.58	79.58	-	-	AVG

Test Mode	IEEE 802.11n HT20 High CH	Temp/Hum	24(°C)/ 33%RH
Test Item	Band Edge	Test Date	December 1, 2017
Polarize	Vertical	Test Engineer	Kevin Kuo
Detector	Peak		

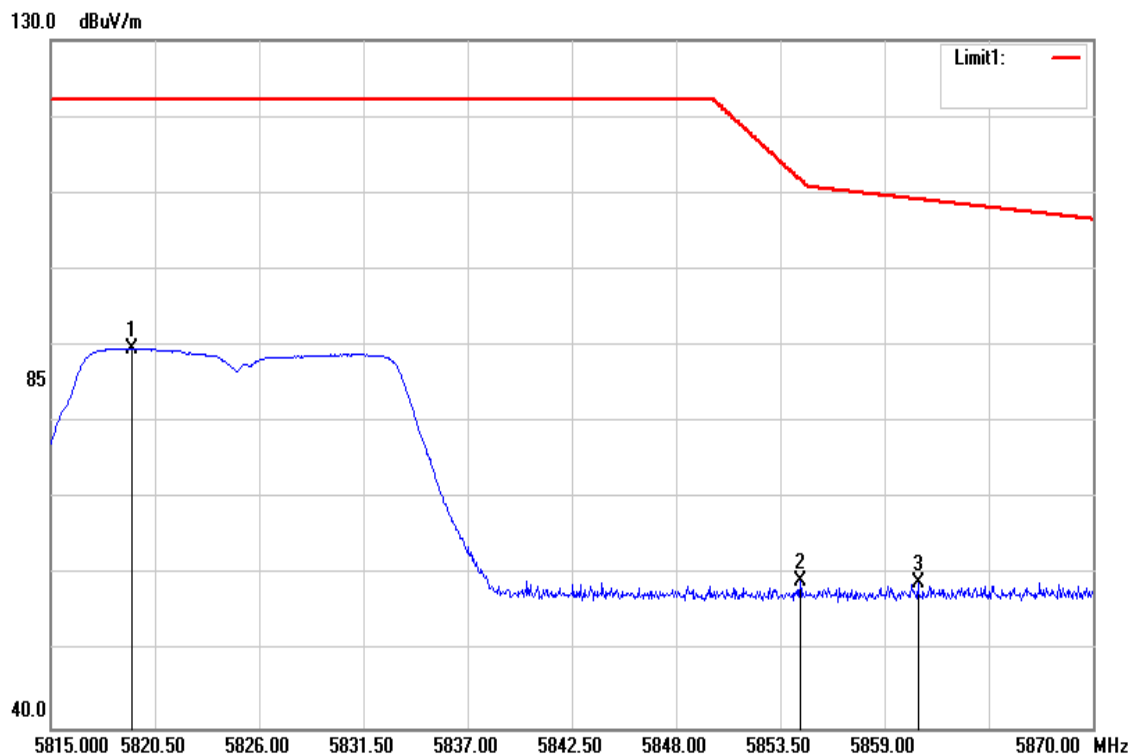

Frequency (MHz)	Reading (dBuV)	Correct Factor (dB/m)	Result (dBuV/m)	Limit (dBuV/m)	Margin (dB)	Remark
5819.290	82.94	6.76	89.70	-	-	peak
5854.545	52.29	6.86	59.15	111.84	-52.69	peak
5860.760	52.07	6.87	58.94	109.19	-50.25	peak

Test Mode	IEEE 802.11n HT20 High CH	Temperature	24(°C)/ 33%RH
Test Item	Band Edge	Test Date	December 1, 2017
Polarize	Vertical	Test Engineer	Kevin Kuo
Detector	Average		

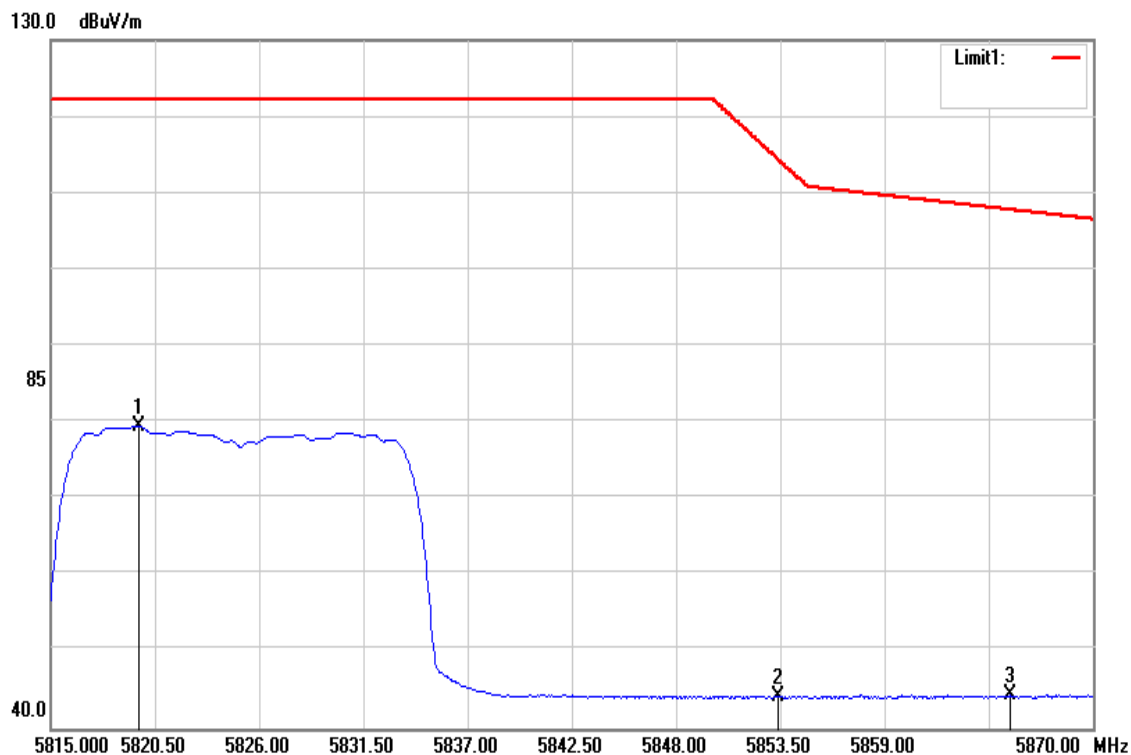

Frequency (MHz)	Reading (dBuV)	Correct Factor (dB/m)	Result (dBuV/m)	Limit (dBuV/m)	Margin (dB)	Remark
5819.620	72.71	6.76	79.47	-	-	AVG
5853.390	37.38	6.86	44.24	114.47	-70.23	AVG
5865.655	37.46	6.89	44.35	107.82	-63.47	AVG

Test Mode	IEEE 802.11n HT40 Low CH	Temp/Hum	24(°C)/ 33%RH
Test Item	Band Edge	Test Date	December 1, 2017
Polarize	Vertical	Test Engineer	Kevin Kuo
Detector	Peak		

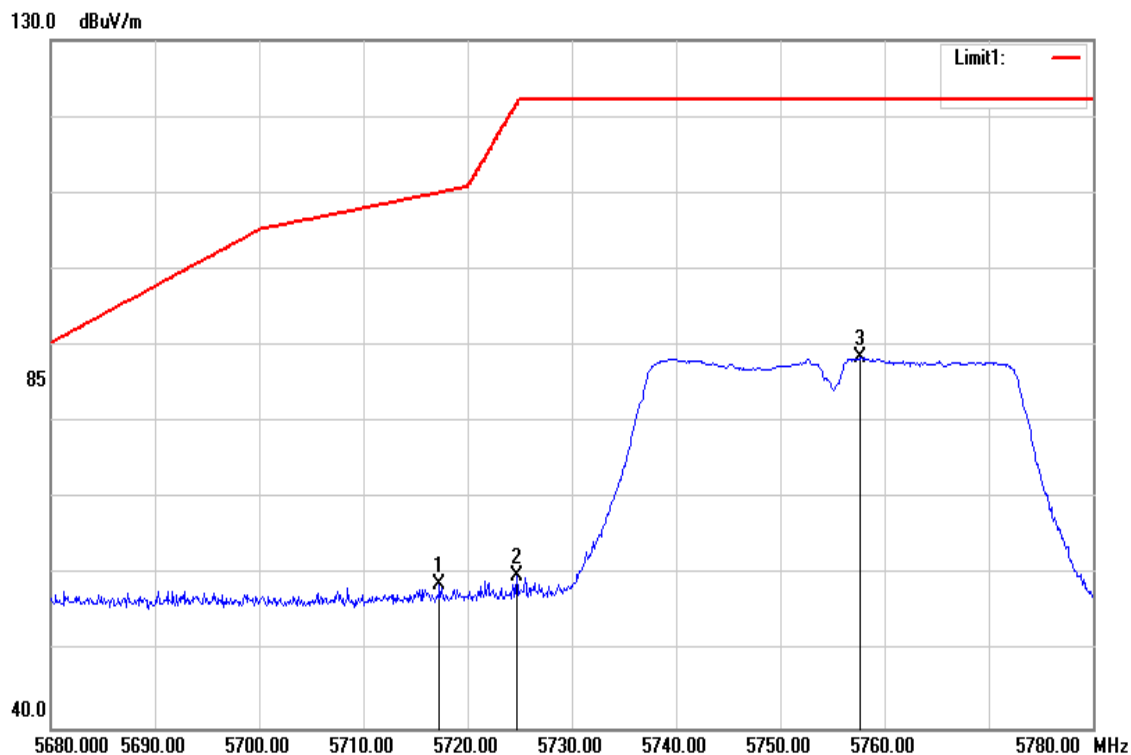

Frequency (MHz)	Reading (dBuV)	Correct Factor (dB/m)	Result (dBuV/m)	Limit (dBuV/m)	Margin (dB)	Remark
5717.300	52.29	6.49	58.78	110.04	-51.26	peak
5724.700	53.43	6.52	59.95	121.52	-61.57	peak
5757.700	81.81	6.61	88.42	-	-	peak

Test Mode	IEEE 802.11n HT40 Low CH	Temperature	24(°C)/ 33%RH
Test Item	Band Edge	Test Date	December 1, 2017
Polarize	Vertical	Test Engineer	Kevin Kuo
Detector	Average		

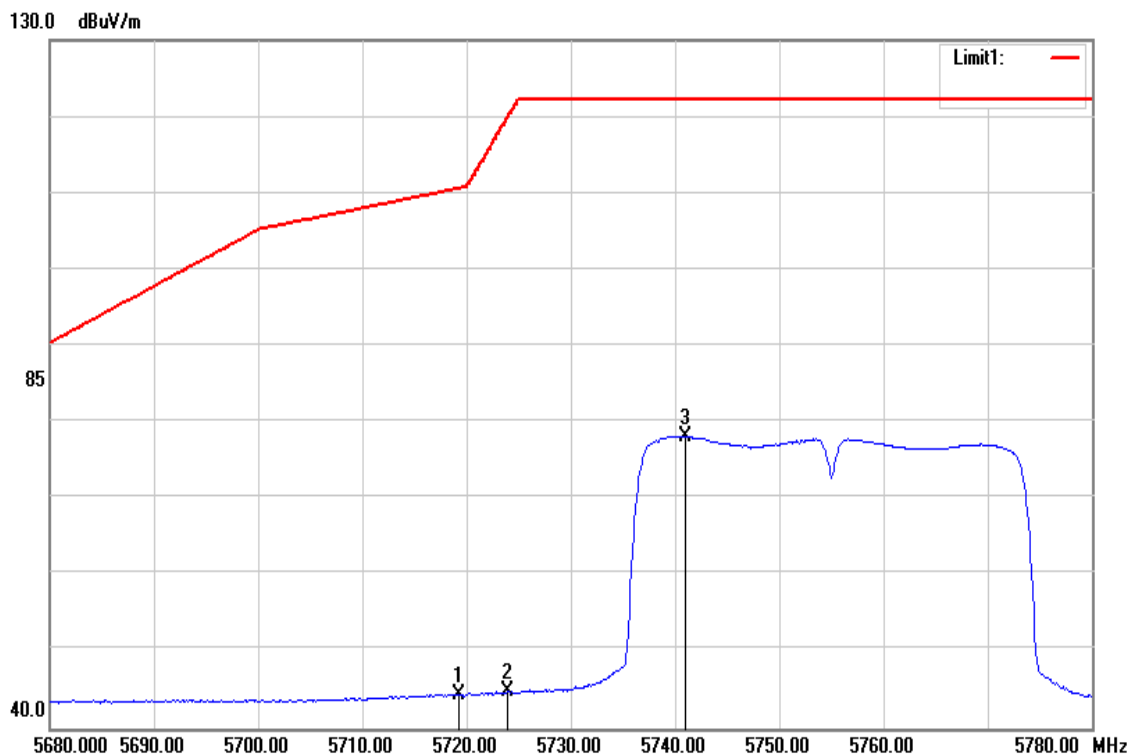

Frequency (MHz)	Reading (dBuV)	Correct Factor (dB/m)	Result (dBuV/m)	Limit (dBuV/m)	Margin (dB)	Remark
5719.300	37.98	6.50	44.48	110.60	-66.12	AVG
5723.900	38.38	6.52	44.90	119.69	-74.79	AVG
5741.000	71.60	6.56	78.16	-	-	AVG

Test Mode	IEEE 802.11n HT40 High CH	Temp/Hum	24(°C)/ 33%RH
Test Item	Band Edge	Test Date	December 1, 2017
Polarize	Vertical	Test Engineer	Kevin Kuo
Detector	Peak		

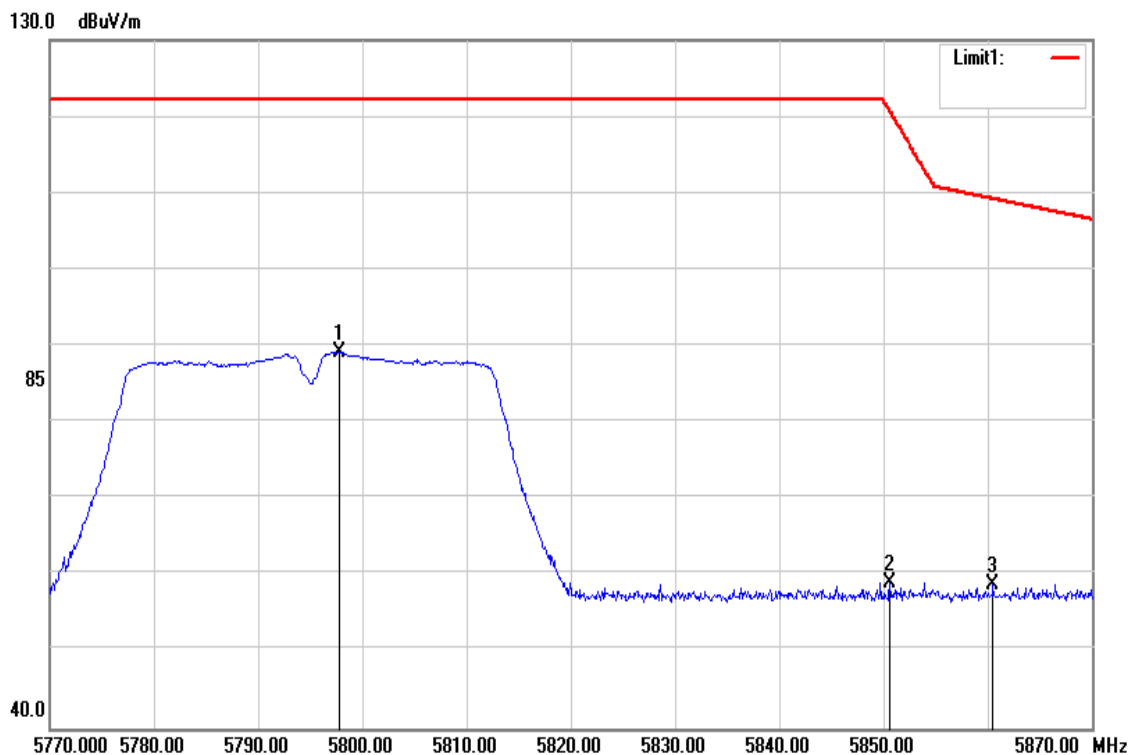

Frequency (MHz)	Reading (dBuV)	Correct Factor (dB/m)	Result (dBuV/m)	Limit (dBuV/m)	Margin (dB)	Remark
5797.800	82.44	6.72	89.16	-	-	peak
5850.600	52.10	6.85	58.95	120.83	-61.88	peak
5860.500	51.88	6.87	58.75	109.26	-50.51	peak

Test Mode	IEEE 802.11n HT40 High CH	Temperature	24(°C)/ 33%RH
Test Item	Band Edge	Test Date	December 1, 2017
Polarize	Vertical	Test Engineer	Kevin Kuo
Detector	Average		

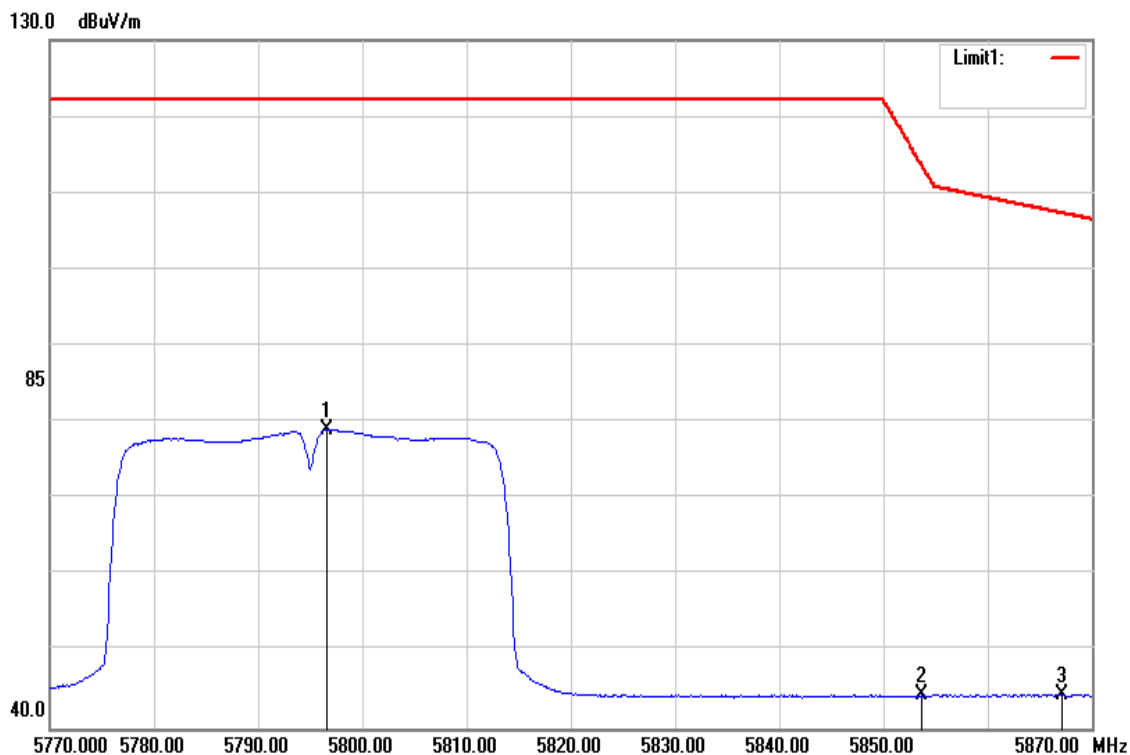

Frequency (MHz)	Reading (dBuV)	Correct Factor (dB/m)	Result (dBuV/m)	Limit (dBuV/m)	Margin (dB)	Remark
5796.600	72.35	6.71	79.06	-	-	AVG
5853.700	37.47	6.85	44.32	113.76	-69.44	AVG
5867.100	37.55	6.89	44.44	107.41	-62.97	AVG

Below 1G Test Data

Test Mode	Mode 1	Temp/Hum	24(°C)/ 33%RH
Test Item	30MHz-1GHz	Test Date	November 30, 2017
Polarize	Vertical	Test Engineer	Kevin Kuo
Detector	Peak and Qusi-peak		

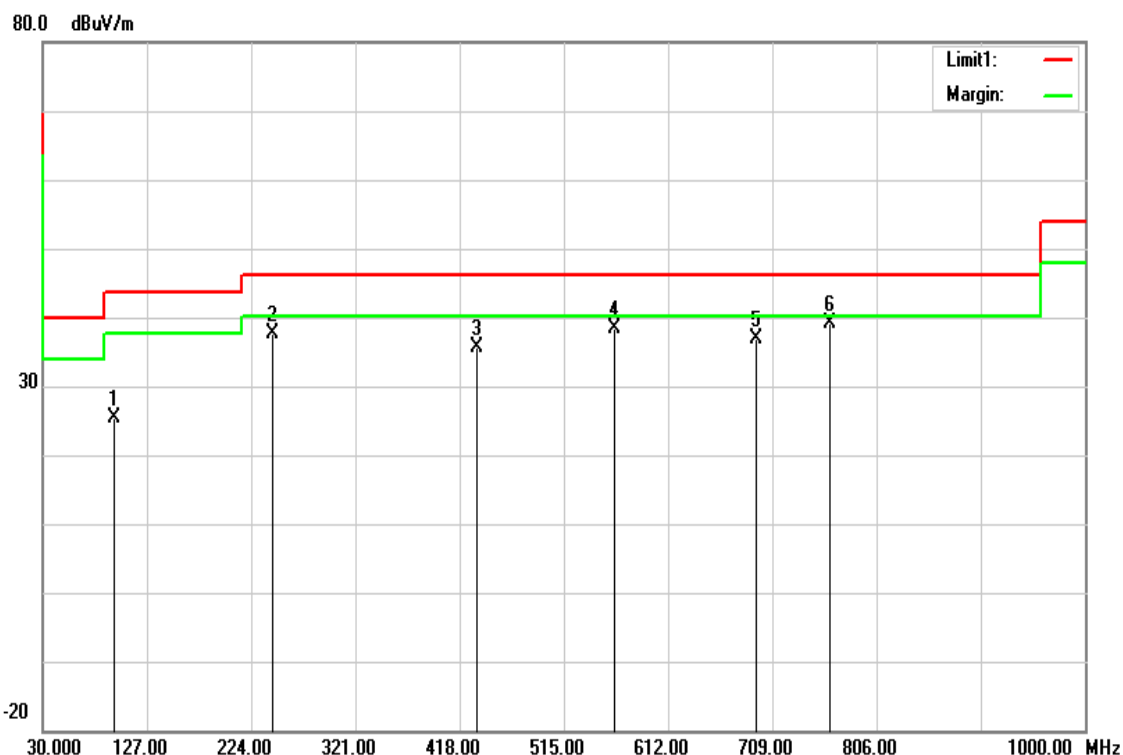

Frequency (MHz)	Reading (dBuV)	Correct Factor (dB/m)	Result (dBuV/m)	Limit (dBuV/m)	Margin (dB)	Remark
95.9600	45.05	-19.65	25.40	43.52	-18.12	peak
244.3700	53.66	-16.00	37.66	46.02	-8.36	peak
433.5200	45.75	-10.19	35.56	46.02	-10.46	peak
562.5300	45.74	-7.40	38.34	46.02	-7.68	peak
693.4800	41.96	-4.97	36.99	46.02	-9.03	peak
762.3500	43.16	-4.06	39.10	46.02	-6.92	peak

Note: No emission found between lowest internal used/generated frequency to 30MHz(9KHz~30MHz)

Test Mode	Mode 1	Temp/Hum	24(°C)/ 33%RH
Test Item	30MHz-1GHz	Test Date	November 30, 2017
Polarize	Horizontal	Test Engineer	Kevin Kuo
Detector	Peak and Qusi-peak		

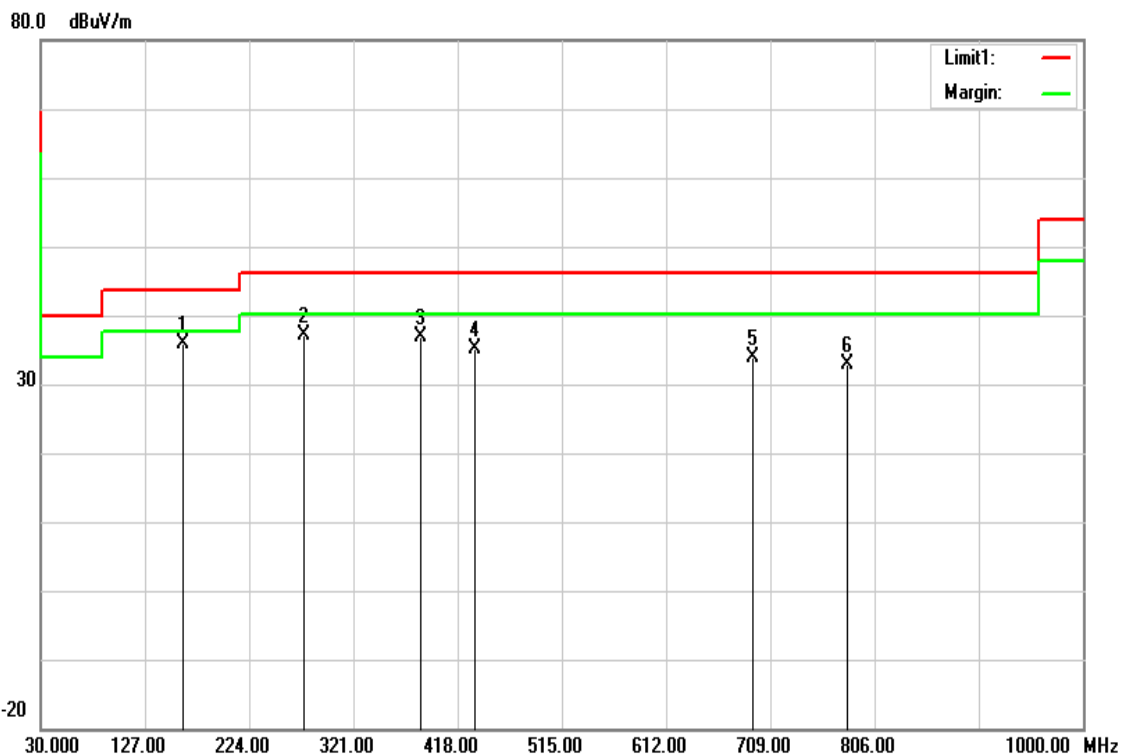

Frequency (MHz)	Reading (dBuV)	Correct Factor (dB/m)	Result (dBuV/m)	Limit (dBuV/m)	Margin (dB)	Remark
161.9200	51.99	-16.07	35.92	43.52	-7.60	peak
274.4400	51.76	-14.62	37.14	46.02	-8.88	peak
383.0800	48.82	-11.93	36.89	46.02	-9.13	peak
433.5200	45.40	-10.19	35.21	46.02	-10.81	peak
692.5100	38.76	-4.98	33.78	46.02	-12.24	peak
780.7800	36.69	-3.73	32.96	46.02	-13.06	peak

Note: No emission found between lowest internal used/generated frequency to 30MHz(9KHz~30MHz)

Above 1G Test Data for UNII-1

Test Mode	IEEE 802.11a Low CH	Temp/Hum	24(°C)/ 33%RH
Test Item	Harmonic	Test Date	December 2, 2017
Polarize	Vertical	Test Engineer	Kevin Kuo
Detector	Peak and Average		

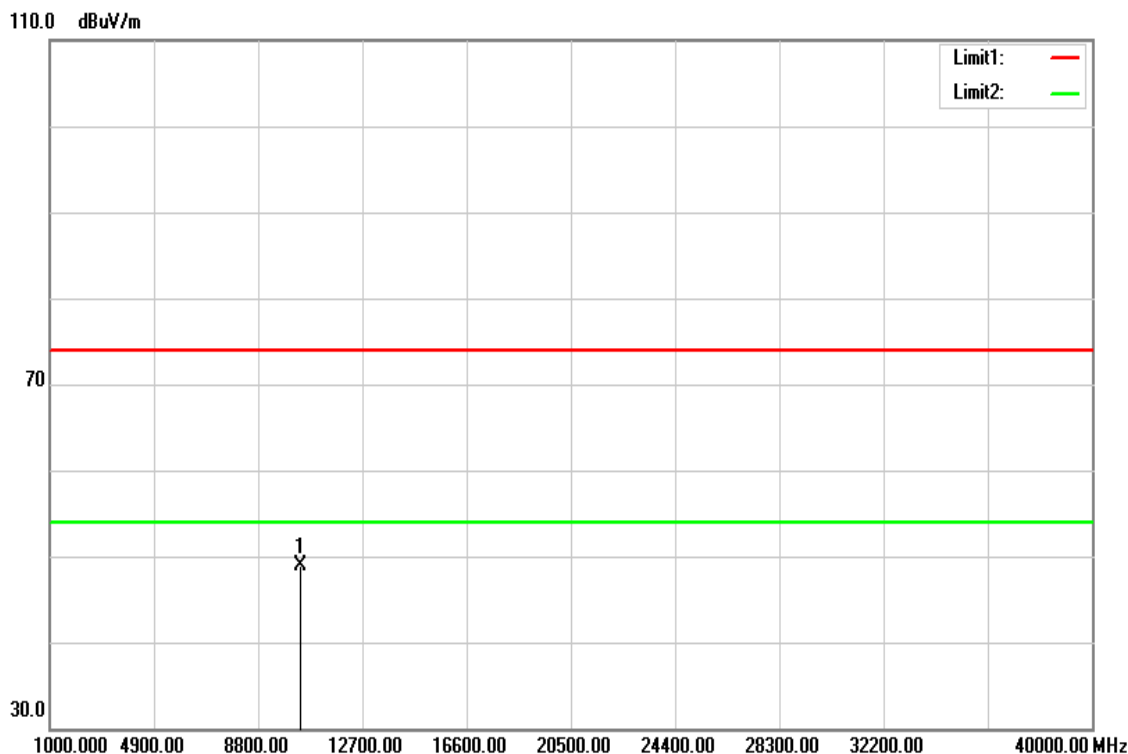

Frequency (MHz)	Reading (dBuV)	Correct Factor (dB/m)	Result (dBuV/m)	Limit (dBuV/m)	Margin (dB)	Remark
10360.000	34.52	14.45	48.97	74.00	-25.03	peak
N/A						

Remark:

1. Measuring frequencies from 1 GHz to the 10th harmonic of highest fundamental frequency.
2. For above 1GHz, the EUT peak value was under average limit, therefore the Average value compliance with the average limit

Test Mode	IEEE 802.11a Low CH	Temp/Hum	24(°C)/ 33%RH
Test Item	Harmonic	Test Date	December 2, 2017
Polarize	Horizontal	Test Engineer	Kevin Kuo
Detector	Peak and Average		

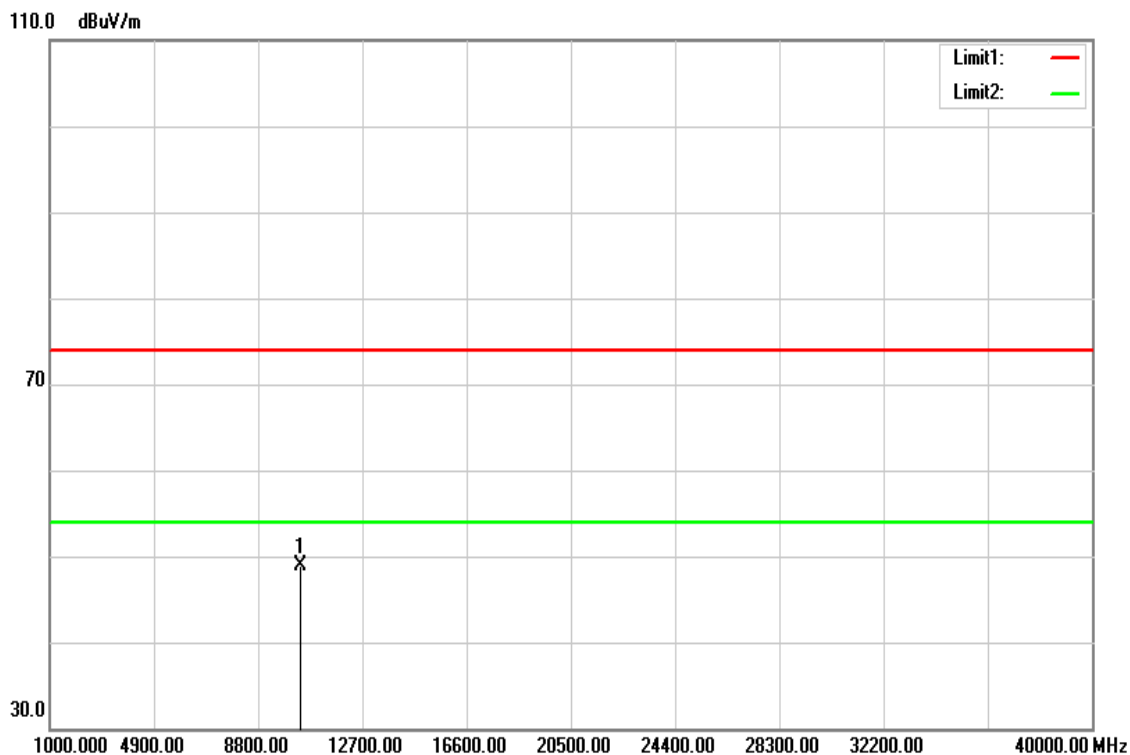

Frequency (MHz)	Reading (dBuV)	Correct Factor (dB/m)	Result (dBuV/m)	Limit (dBuV/m)	Margin (dB)	Remark
10360.000	34.47	14.45	48.92	74.00	-25.08	peak
N/A						

Remark:

1. Measuring frequencies from 1 GHz to the 10th harmonic of highest fundamental frequency.
2. For above 1GHz, the EUT peak value was under average limit, therefore the Average value compliance with the average limit

Test Mode	IEEE 802.11a Mid CH	Temp/Hum	24(°C)/ 33%RH
Test Item	Harmonic	Test Date	December 2, 2017
Polarize	Vertical	Test Engineer	Kevin Kuo
Detector	Peak and Average		

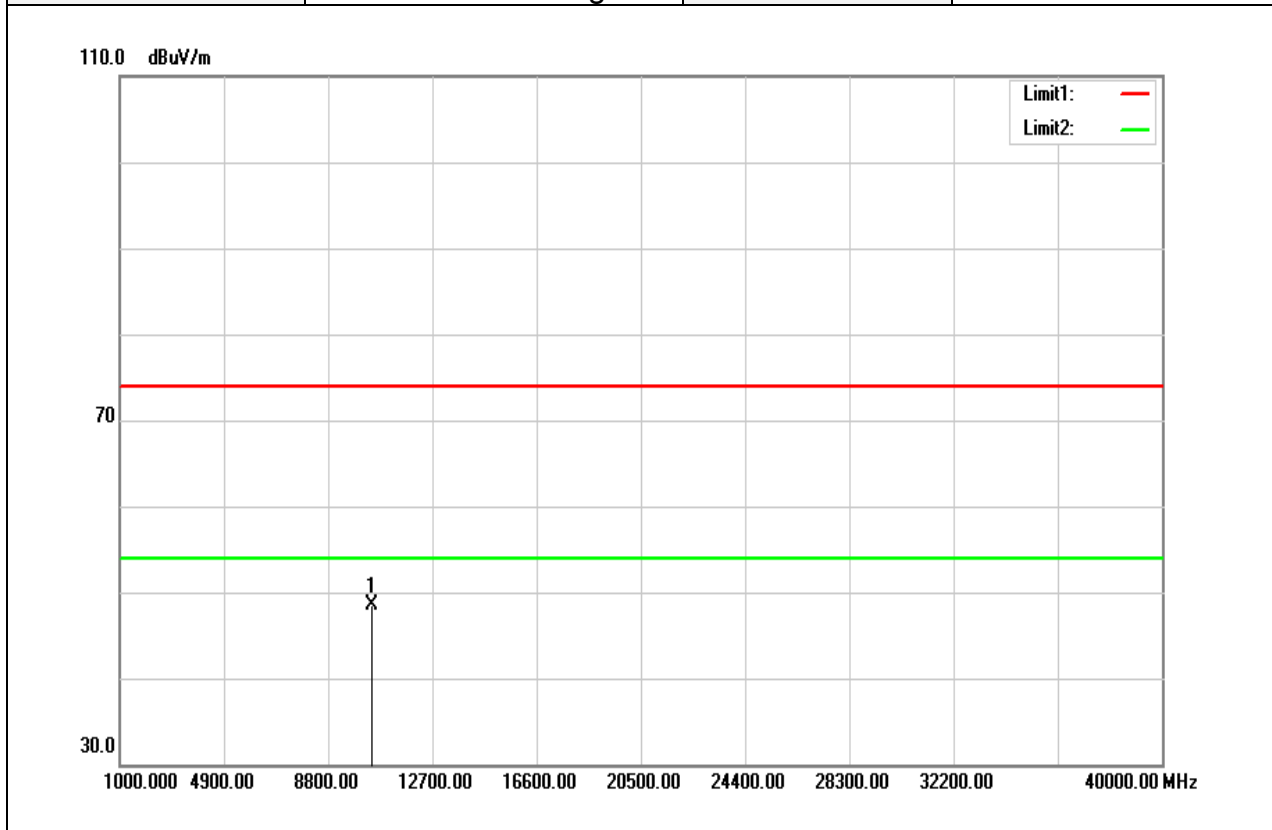

Frequency (MHz)	Reading (dBuV)	Correct Factor (dB/m)	Result (dBuV/m)	Limit (dBuV/m)	Margin (dB)	Remark
10440.000	33.79	14.71	48.50	74.00	-25.50	peak
N/A						

Remark:

1. Measuring frequencies from 1 GHz to the 10th harmonic of highest fundamental frequency.
2. For above 1GHz, the EUT peak value was under average limit, therefore the Average value compliance with the average limit

Test Mode	IEEE 802.11a Mid CH	Temp/Hum	24(°C)/ 33%RH
Test Item	Harmonic	Test Date	December 2, 2017
Polarize	Horizontal	Test Engineer	Kevin Kuo
Detector	Peak and Average		

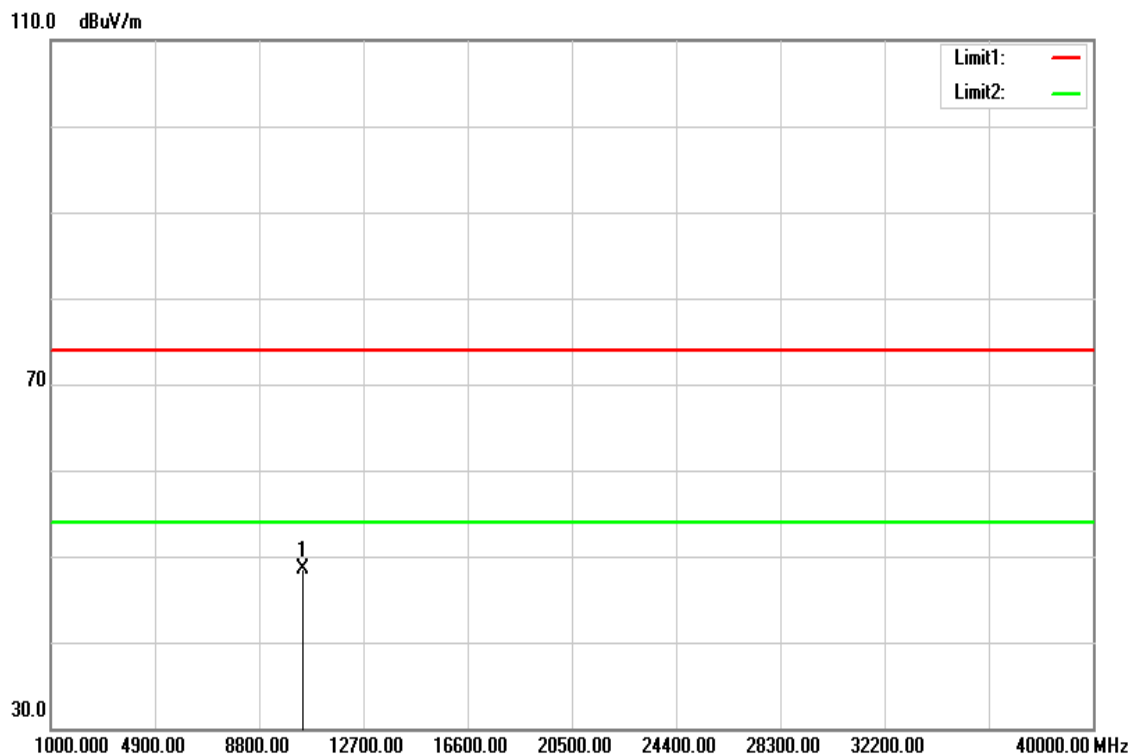

Frequency (MHz)	Reading (dBuV)	Correct Factor (dB/m)	Result (dBuV/m)	Limit (dBuV/m)	Margin (dB)	Remark
10440.000	33.79	14.71	48.50	74.00	-25.50	peak
N/A						

Remark:

1. Measuring frequencies from 1 GHz to the 10th harmonic of highest fundamental frequency.
2. For above 1GHz, the EUT peak value was under average limit, therefore the Average value compliance with the average limit

Test Mode	IEEE 802.11a High CH	Temp/Hum	24(°C)/ 33%RH
Test Item	Harmonic	Test Date	December 2, 2017
Polarize	Vertical	Test Engineer	Kevin Kuo
Detector	Peak and Average		

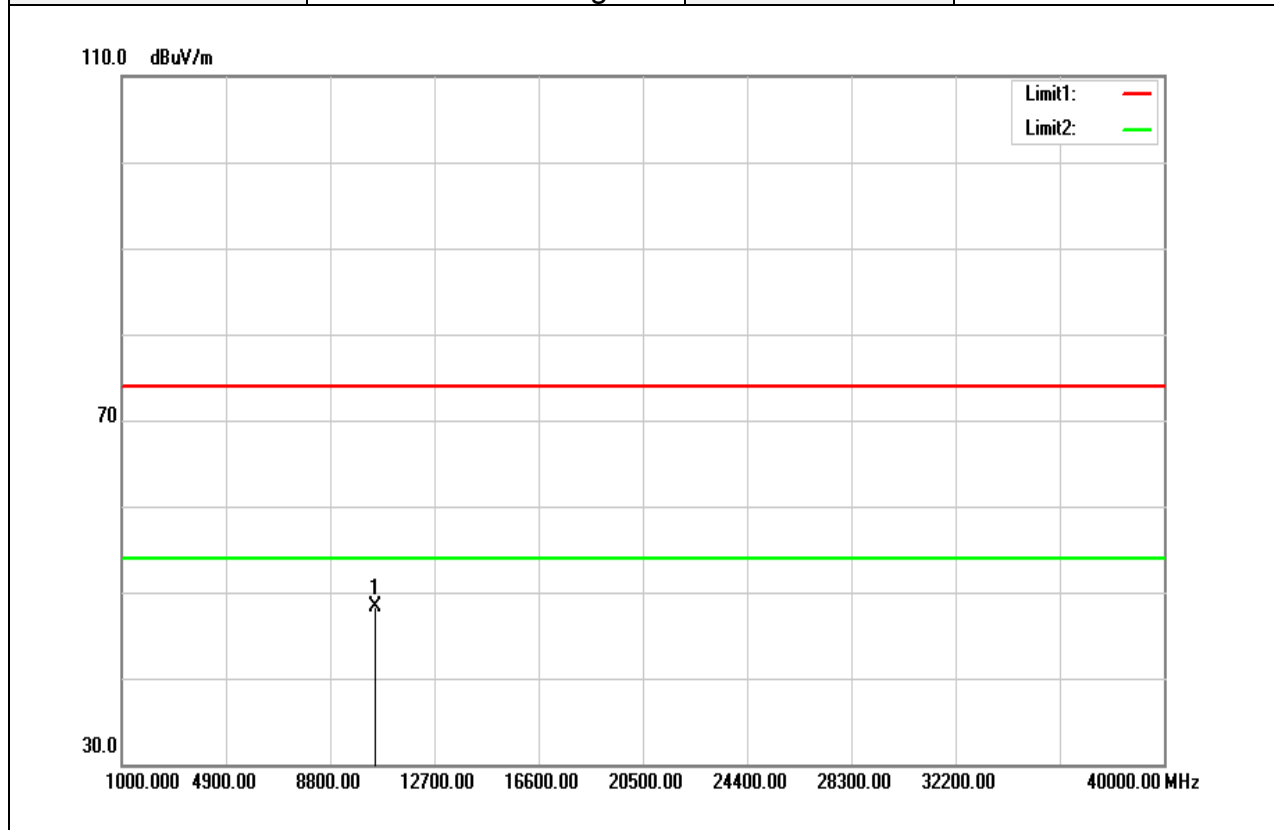

Frequency (MHz)	Reading (dBuV)	Correct Factor (dB/m)	Result (dBuV/m)	Limit (dBuV/m)	Margin (dB)	Remark
10480.000	33.50	14.84	48.34	74.00	-25.66	peak
N/A						

Remark:

1. Measuring frequencies from 1 GHz to the 10th harmonic of highest fundamental frequency.
2. For above 1GHz, the EUT peak value was under average limit, therefore the Average value compliance with the average limit

Test Mode	IEEE 802.11a High CH	Temp/Hum	24(°C)/ 33%RH
Test Item	Harmonic	Test Date	December 2, 2017
Polarize	Horizontal	Test Engineer	Kevin Kuo
Detector	Peak and Average		

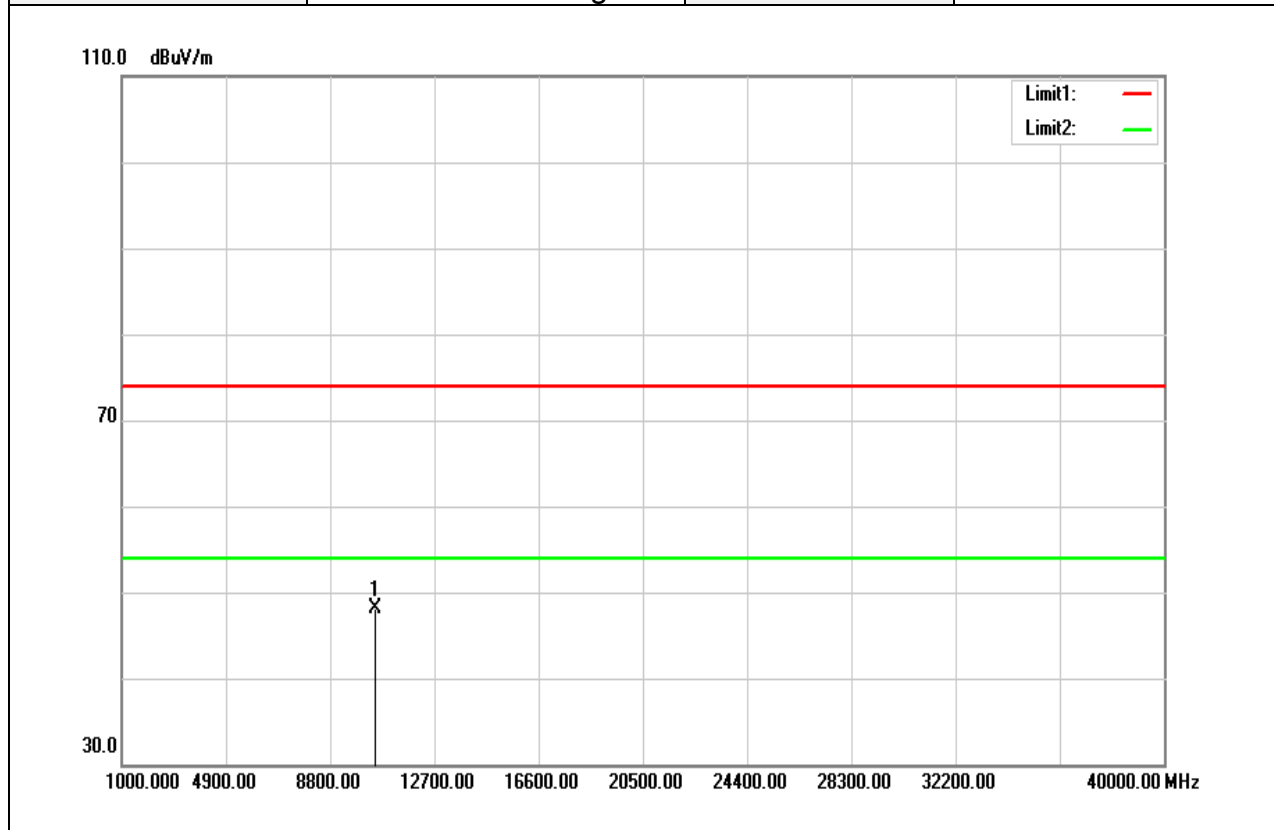

Frequency (MHz)	Reading (dBuV)	Correct Factor (dB/m)	Result (dBuV/m)	Limit (dBuV/m)	Margin (dB)	Remark
10480.000	33.27	14.84	48.11	74.00	-25.89	peak
N/A						

Remark:

1. Measuring frequencies from 1 GHz to the 10th harmonic of highest fundamental frequency.
2. For above 1GHz, the EUT peak value was under average limit, therefore the Average value compliance with the average limit

Test Mode	IEEE 802.11n HT20 Low CH	Temp/Hum	24(°C)/ 33%RH
Test Item	Harmonic	Test Date	December 2, 2017
Polarize	Vertical	Test Engineer	Kevin Kuo
Detector	Peak and Average		

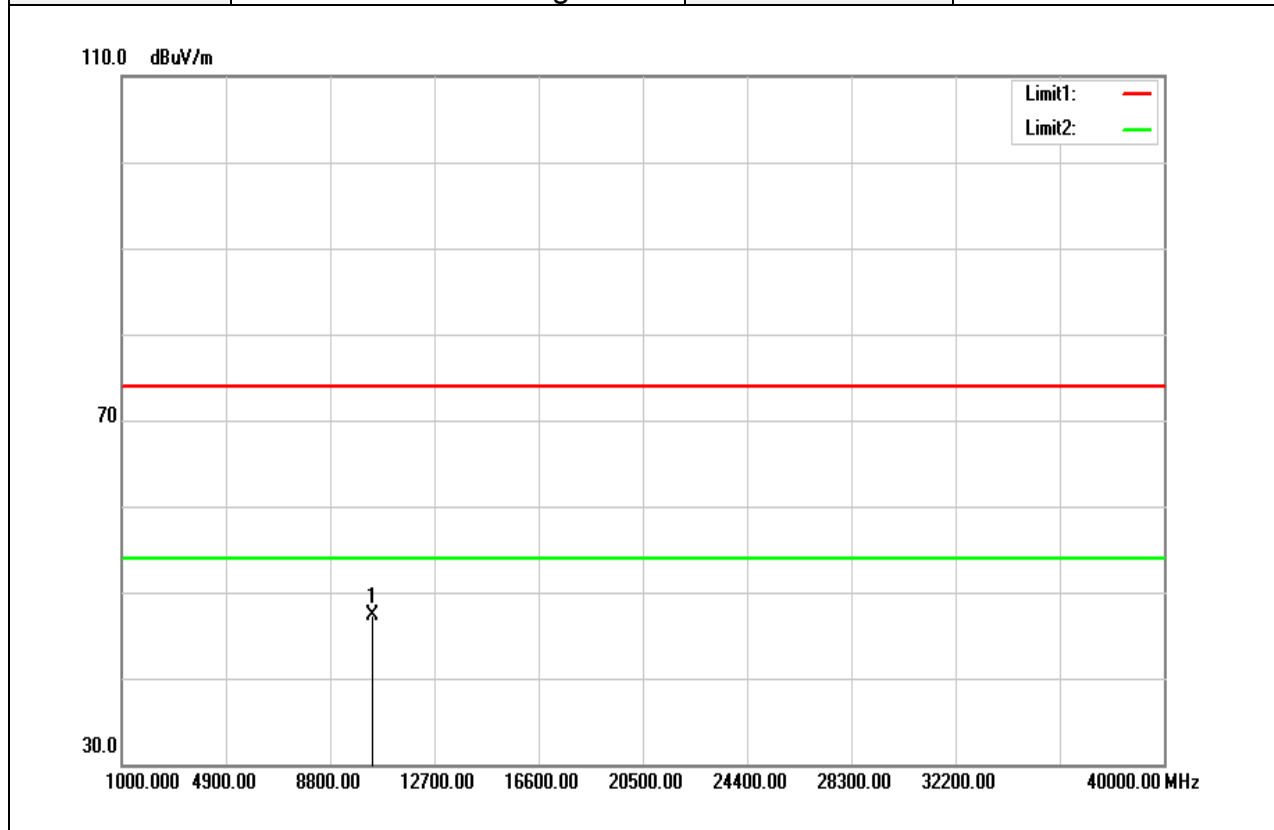

Frequency (MHz)	Reading (dBuV)	Correct Factor (dB/m)	Result (dBuV/m)	Limit (dBuV/m)	Margin (dB)	Remark
10360.000	32.92	14.45	47.37	74.00	-26.63	peak
N/A						

Remark:

1. Measuring frequencies from 1 GHz to the 10th harmonic of highest fundamental frequency.
2. For above 1GHz, the EUT peak value was under average limit, therefore the Average value compliance with the average limit

Test Mode	IEEE 802.11n HT20 Low CH	Temp/Hum	24(°C)/ 33%RH
Test Item	Harmonic	Test Date	December 2, 2017
Polarize	Horizontal	Test Engineer	Kevin Kuo
Detector	Peak and Average		

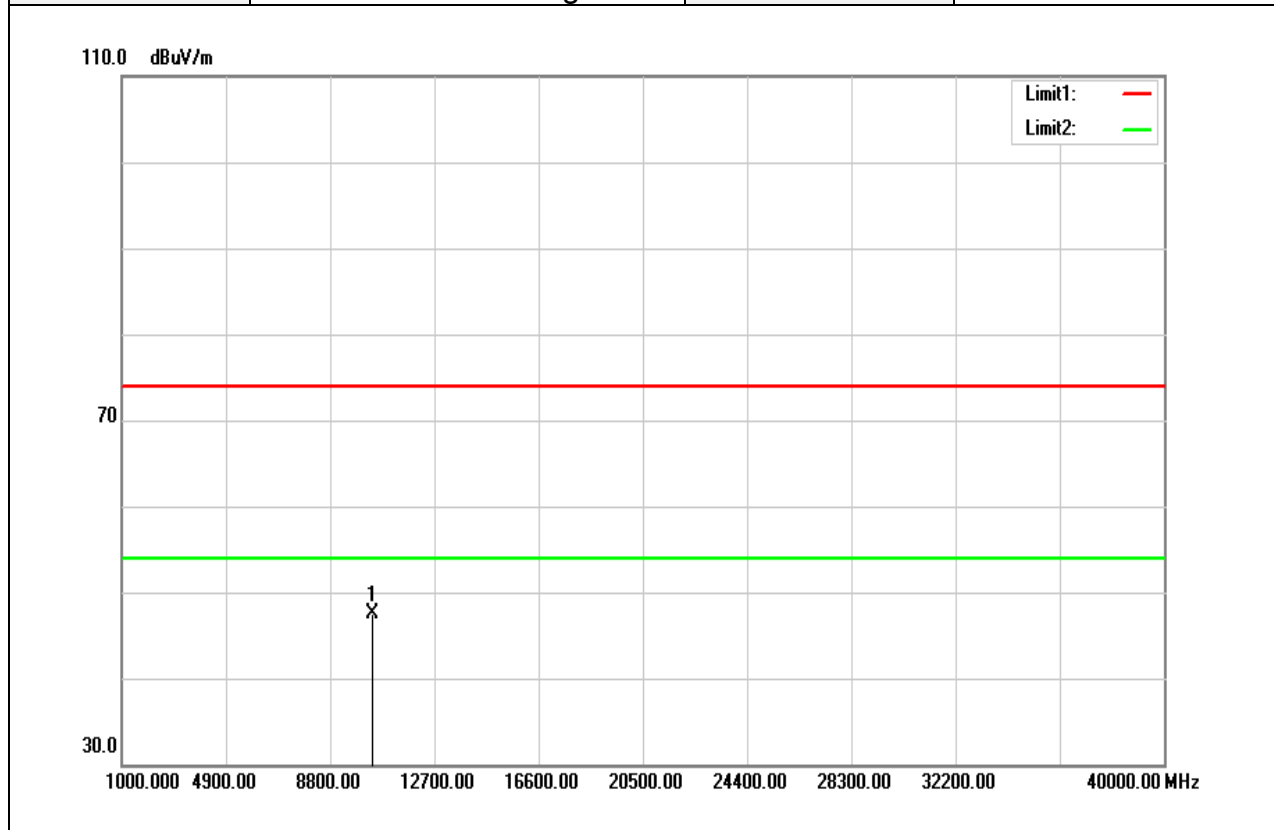

Frequency (MHz)	Reading (dBuV)	Correct Factor (dB/m)	Result (dBuV/m)	Limit (dBuV/m)	Margin (dB)	Remark
10360.000	33.07	14.45	47.52	74.00	-26.48	peak
N/A						

Remark:

1. Measuring frequencies from 1 GHz to the 10th harmonic of highest fundamental frequency.
2. For above 1GHz, the EUT peak value was under average limit, therefore the Average value compliance with the average limit

Test Mode	IEEE 802.11n HT20 Mid CH	Temp/Hum	24(°C)/ 33%RH
Test Item	Harmonic	Test Date	December 2, 2017
Polarize	Vertical	Test Engineer	Kevin Kuo
Detector	Peak and Average		

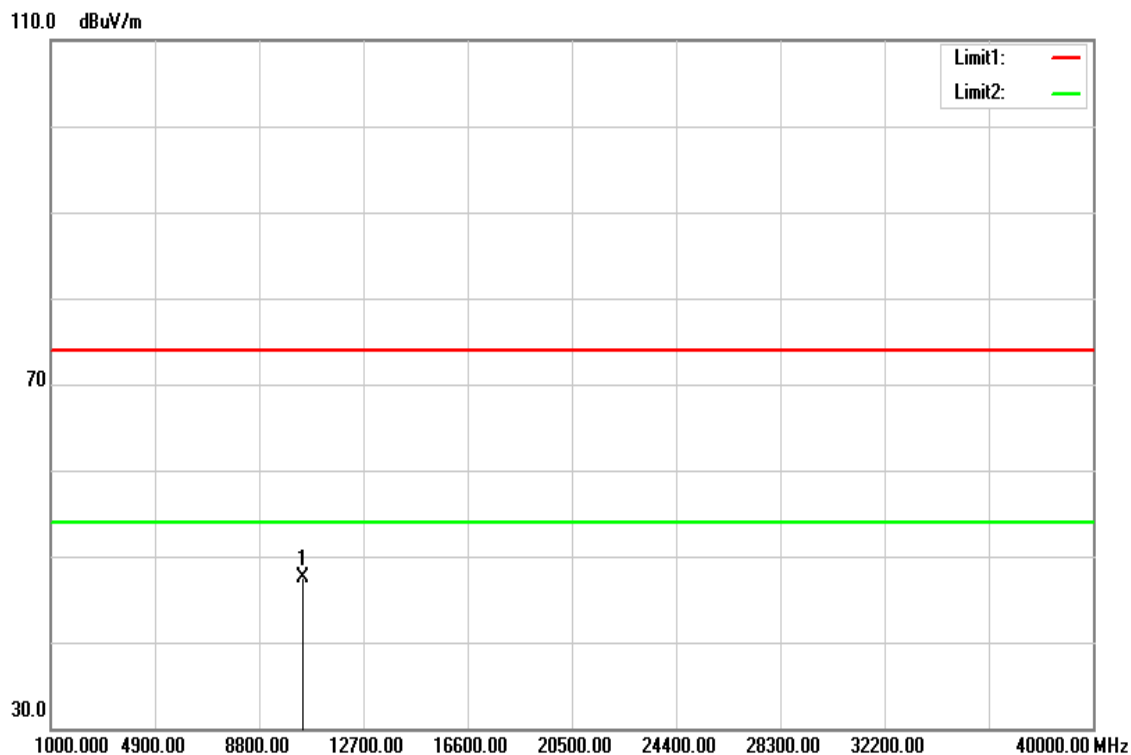

Frequency (MHz)	Reading (dBuV)	Correct Factor (dB/m)	Result (dBuV/m)	Limit (dBuV/m)	Margin (dB)	Remark
10440.000	32.88	14.71	47.59	74.00	-26.41	peak
N/A						

Remark:

1. Measuring frequencies from 1 GHz to the 10th harmonic of highest fundamental frequency.
2. For above 1GHz, the EUT peak value was under average limit, therefore the Average value compliance with the average limit

Test Mode	IEEE 802.11n HT20 Mid CH	Temp/Hum	24(°C)/ 33%RH
Test Item	Harmonic	Test Date	December 2, 2017
Polarize	Horizontal	Test Engineer	Kevin Kuo
Detector	Peak and Average		

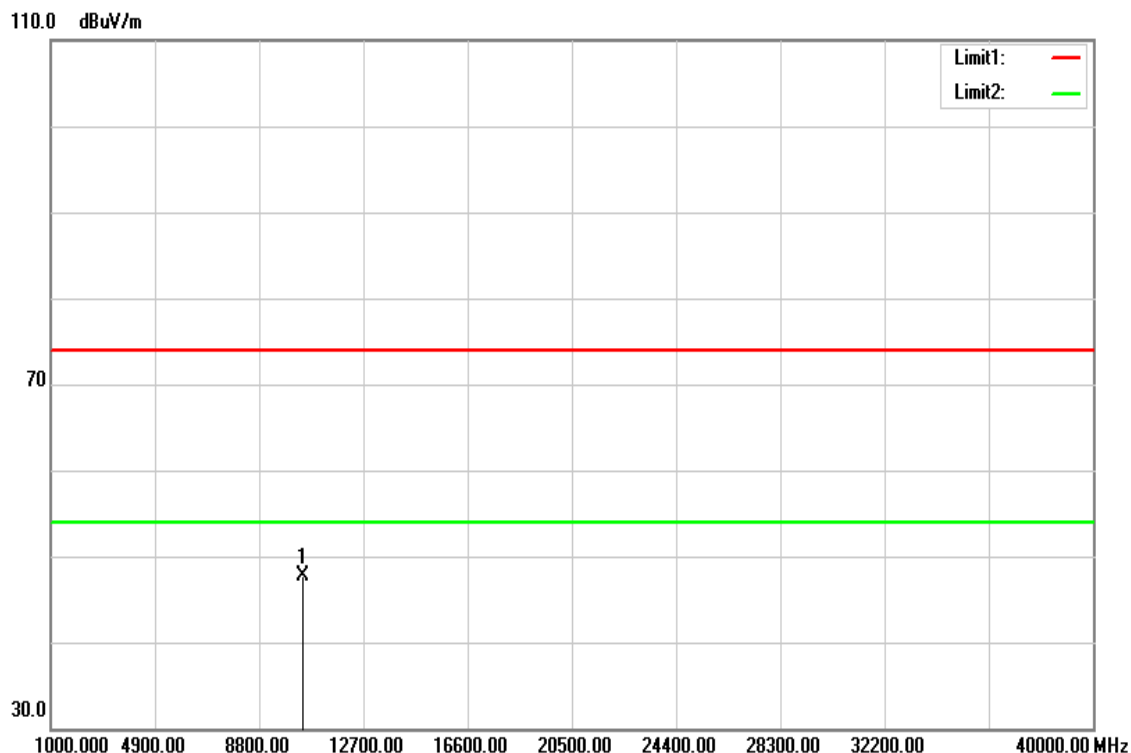

Frequency (MHz)	Reading (dBuV)	Correct Factor (dB/m)	Result (dBuV/m)	Limit (dBuV/m)	Margin (dB)	Remark
10440.000	33.00	14.71	47.71	74.00	-26.29	peak
N/A						

Remark:

1. Measuring frequencies from 1 GHz to the 10th harmonic of highest fundamental frequency.
2. For above 1GHz, the EUT peak value was under average limit, therefore the Average value compliance with the average limit

Test Mode	IEEE 802.11n HT20 High CH	Temp/Hum	24(°C)/ 33%RH
Test Item	Harmonic	Test Date	December 2, 2017
Polarize	Vertical	Test Engineer	Kevin Kuo
Detector	Peak and Average		

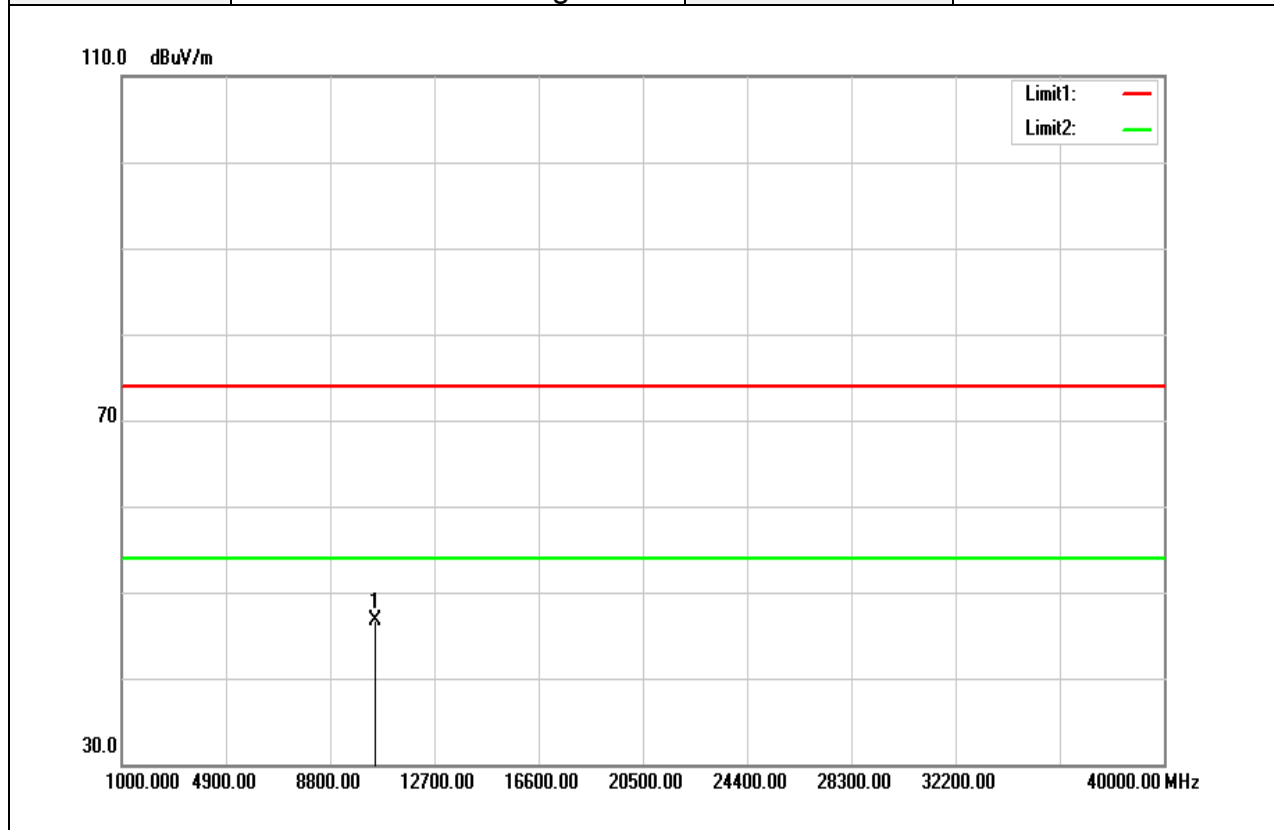

Frequency (MHz)	Reading (dBuV)	Correct Factor (dB/m)	Result (dBuV/m)	Limit (dBuV/m)	Margin (dB)	Remark
10480.000	31.77	14.84	46.61	74.00	-27.39	peak
N/A						

Remark:

1. Measuring frequencies from 1 GHz to the 10th harmonic of highest fundamental frequency.
2. For above 1GHz, the EUT peak value was under average limit, therefore the Average value compliance with the average limit

Test Mode	IEEE 802.11n HT20 High CH	Temp/Hum	24(°C)/ 33%RH
Test Item	Harmonic	Test Date	December 2, 2017
Polarize	Horizontal	Test Engineer	Kevin Kuo
Detector	Peak and Average		

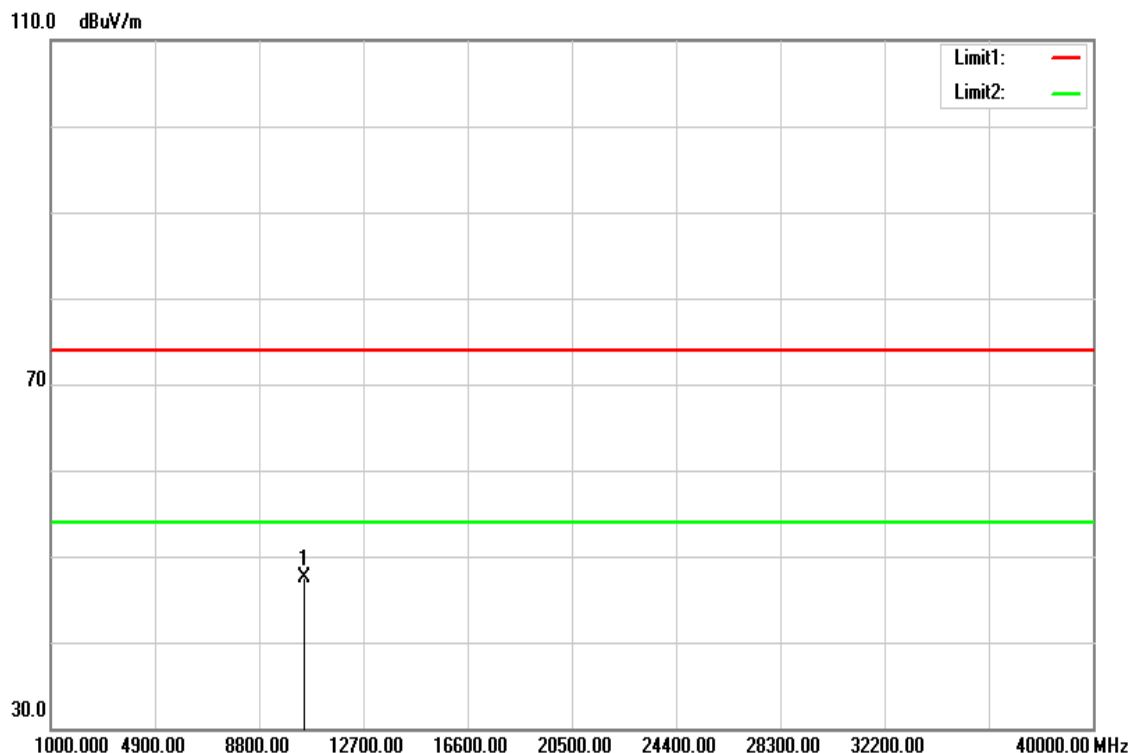

Frequency (MHz)	Reading (dBuV)	Correct Factor (dB/m)	Result (dBuV/m)	Limit (dBuV/m)	Margin (dB)	Remark
10480.000	32.74	14.84	47.58	74.00	-26.42	peak
N/A						

Remark:

1. Measuring frequencies from 1 GHz to the 10th harmonic of highest fundamental frequency.
2. For above 1GHz, the EUT peak value was under average limit, therefore the Average value compliance with the average limit

Test Mode	IEEE 802.11n HT40 Low CH	Temp/Hum	24(°C)/ 33%RH
Test Item	Harmonic	Test Date	December 2, 2017
Polarize	Vertical	Test Engineer	Kevin Kuo
Detector	Peak and Average		

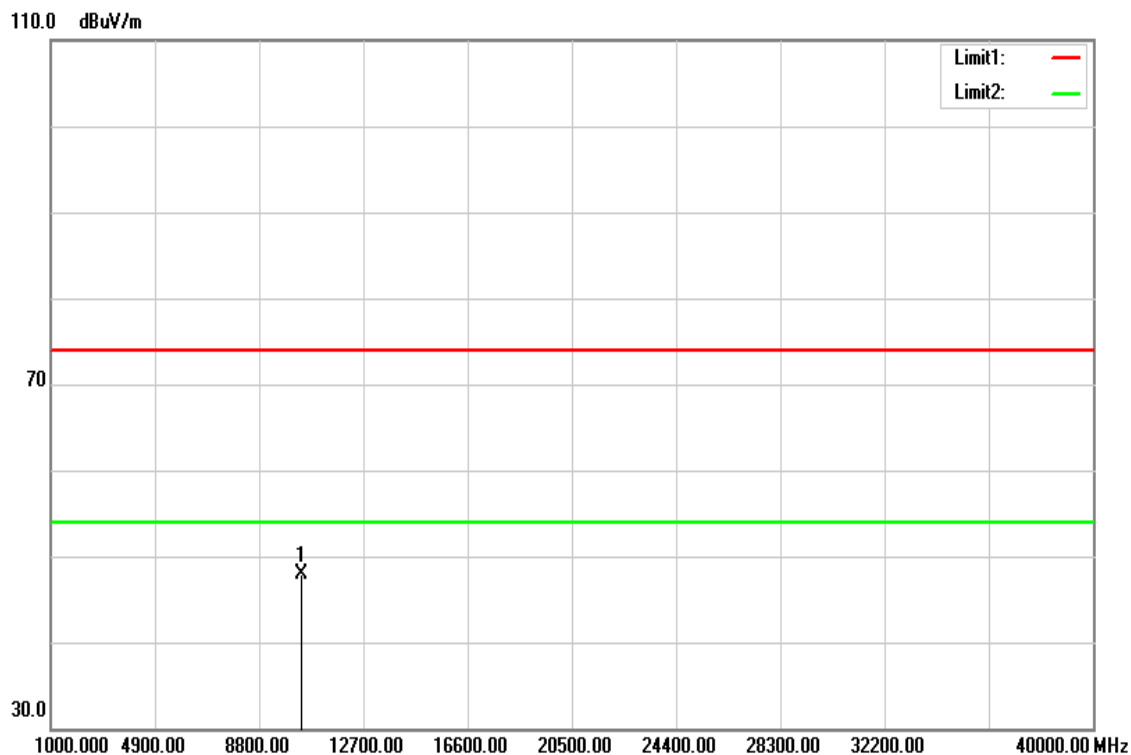

Frequency (MHz)	Reading (dBuV)	Correct Factor (dB/m)	Result (dBuV/m)	Limit (dBuV/m)	Margin (dB)	Remark
10380.000	33.32	14.50	47.82	74.00	-26.18	peak
N/A						

Remark:

1. Measuring frequencies from 1 GHz to the 10th harmonic of highest fundamental frequency.
2. For above 1GHz, the EUT peak value was under average limit, therefore the Average value compliance with the average limit

Test Mode	IEEE 802.11n HT40 Low CH	Temp/Hum	24(°C)/ 33%RH
Test Item	Harmonic	Test Date	December 2, 2017
Polarize	Horizontal	Test Engineer	Kevin Kuo
Detector	Peak and Average		

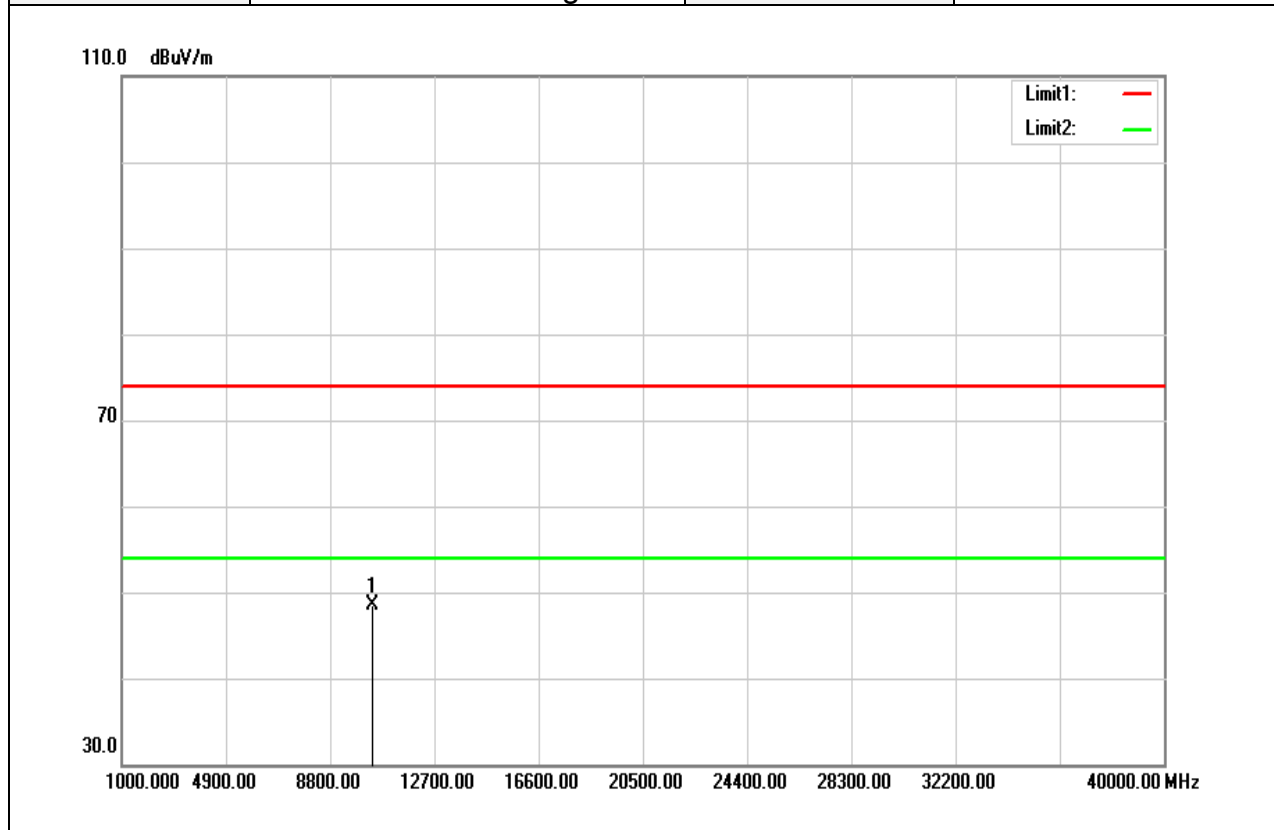

Frequency (MHz)	Reading (dBuV)	Correct Factor (dB/m)	Result (dBuV/m)	Limit (dBuV/m)	Margin (dB)	Remark
10380.000	33.91	14.50	48.41	74.00	-25.59	peak
N/A						

Remark:

1. Measuring frequencies from 1 GHz to the 10th harmonic of highest fundamental frequency.
2. For above 1GHz, the EUT peak value was under average limit, therefore the Average value compliance with the average limit

Test Mode	IEEE 802.11n HT40 High CH	Temp/Hum	24(°C)/ 33%RH
Test Item	Harmonic	Test Date	December 2, 2017
Polarize	Vertical	Test Engineer	Kevin Kuo
Detector	Peak and Average		

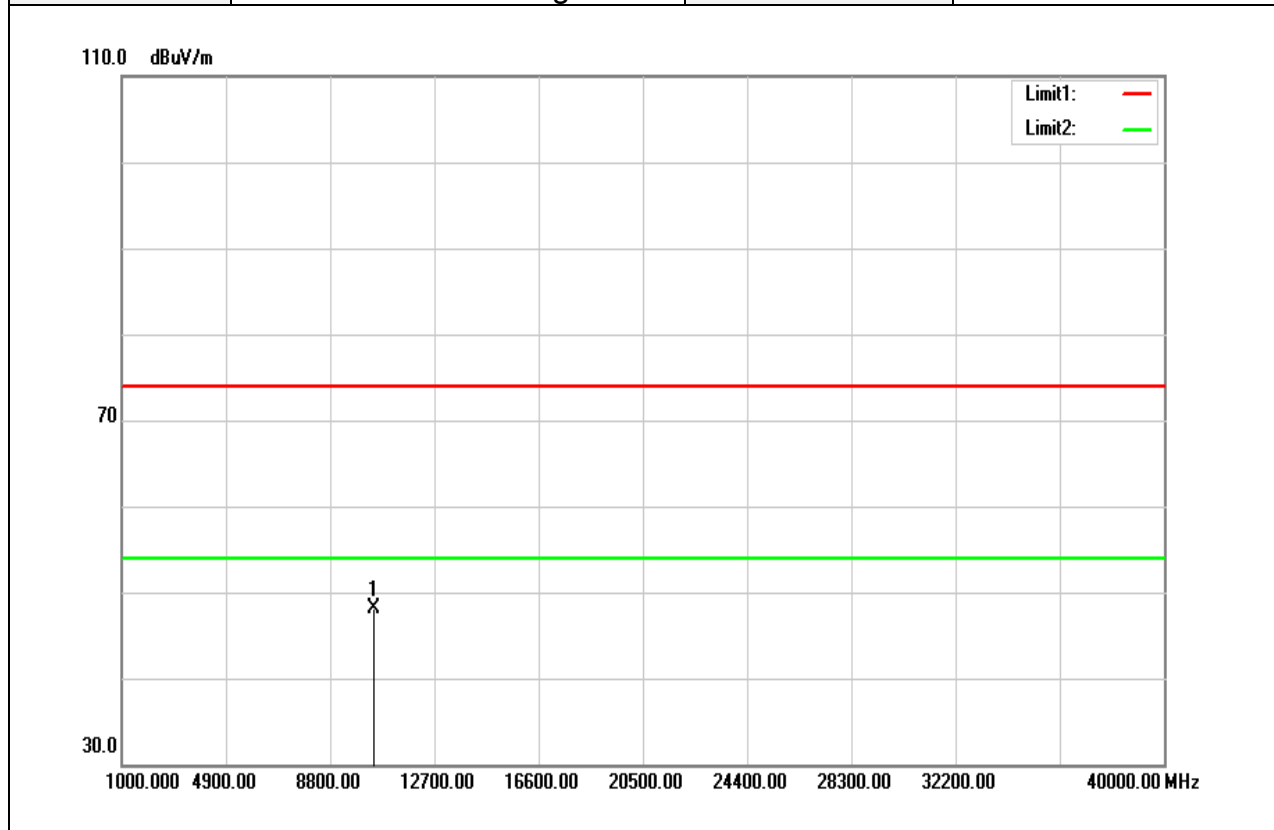

Frequency (MHz)	Reading (dBuV)	Correct Factor (dB/m)	Result (dBuV/m)	Limit (dBuV/m)	Margin (dB)	Remark
10460.000	33.33	14.79	48.12	74.00	-25.88	peak
N/A						

Remark:

1. Measuring frequencies from 1 GHz to the 10th harmonic of highest fundamental frequency.
2. For above 1GHz, the EUT peak value was under average limit, therefore the Average value compliance with the average limit

Test Mode	IEEE 802.11n HT40 High CH	Temp/Hum	24(°C)/ 33%RH
Test Item	Harmonic	Test Date	December 2, 2017
Polarize	Horizontal	Test Engineer	Kevin Kuo
Detector	Peak and Average		

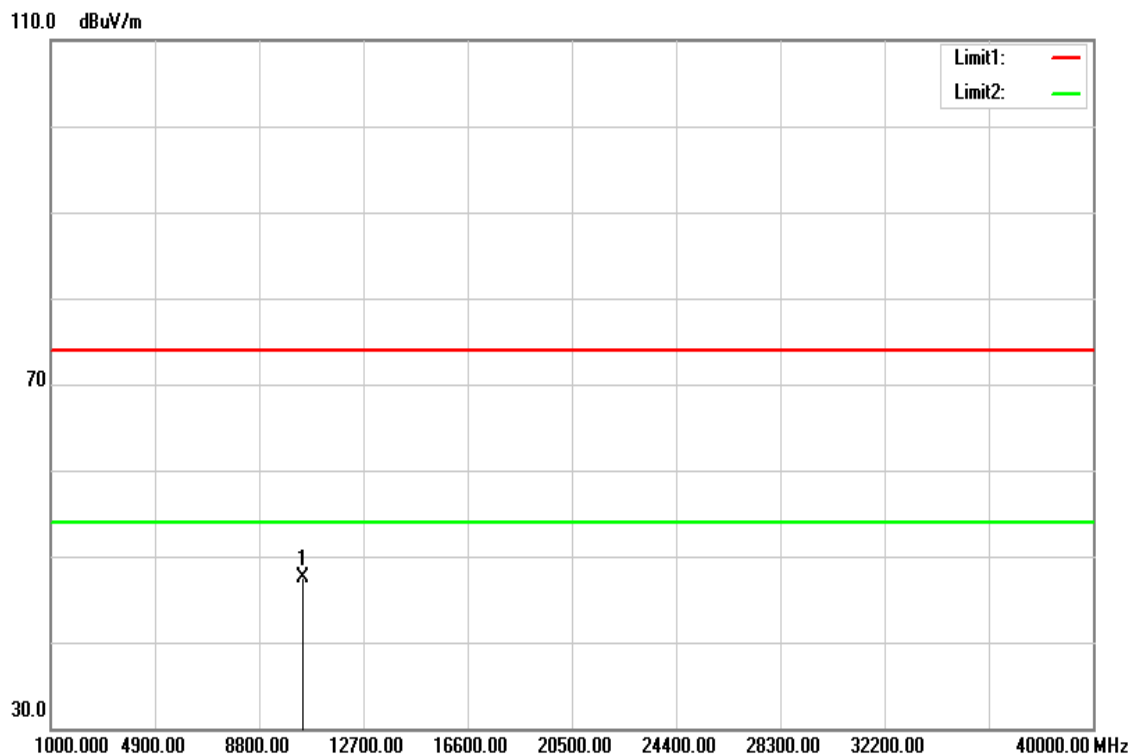

Frequency (MHz)	Reading (dBuV)	Correct Factor (dB/m)	Result (dBuV/m)	Limit (dBuV/m)	Margin (dB)	Remark
10460.000	32.62	14.79	47.41	74.00	-26.59	peak
N/A						

Remark:

1. Measuring frequencies from 1 GHz to the 10th harmonic of highest fundamental frequency.
2. For above 1GHz, the EUT peak value was under average limit, therefore the Average value compliance with the average limit

Above 1G Test Data for UNII-2a

Test Mode	IEEE 802.11a Low CH	Temp/Hum	24(°C)/ 33%RH
Test Item	Harmonic	Test Date	December 2, 2017
Polarize	Vertical	Test Engineer	Kevin Kuo
Detector	Peak and Average		

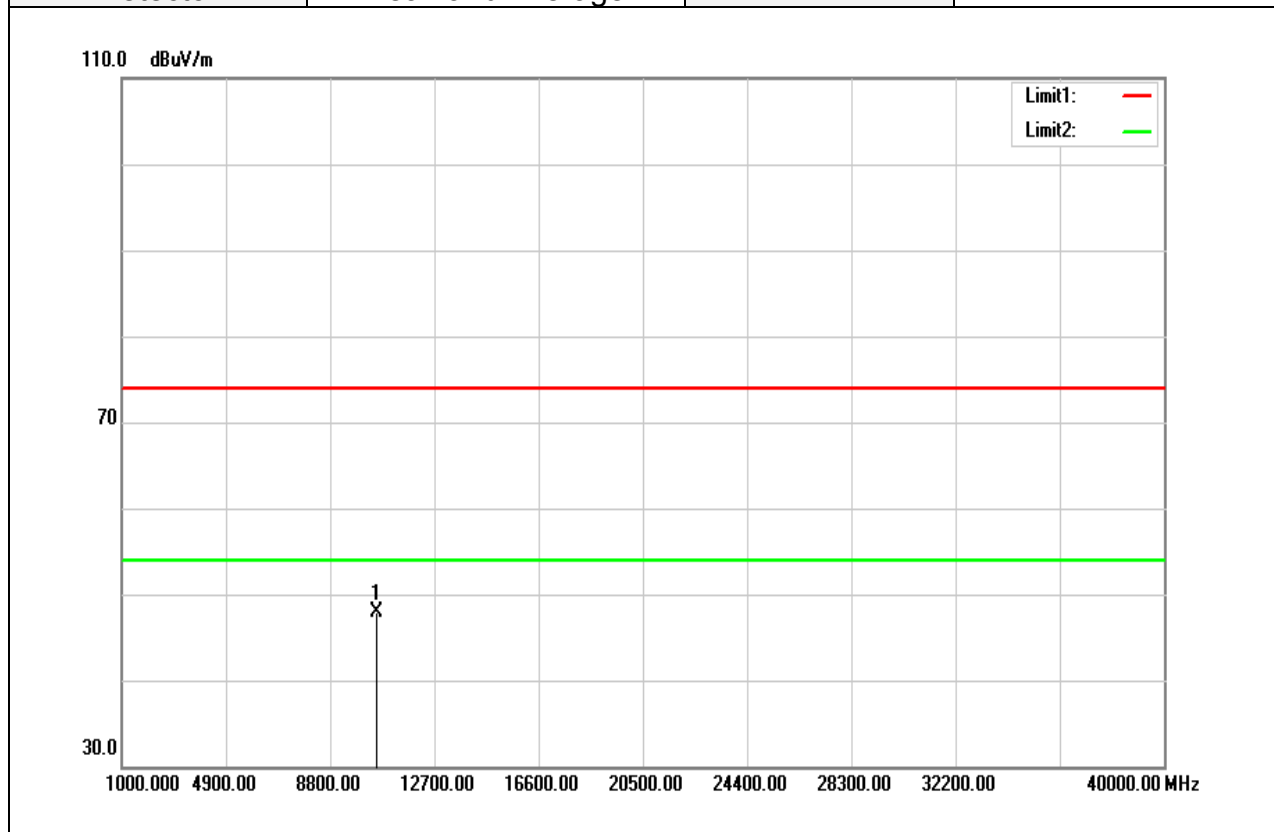

Frequency (MHz)	Reading (dBuV)	Correct Factor (dB/m)	Result (dBuV/m)	Limit (dBuV/m)	Margin (dB)	Remark
10520.000	32.91	14.97	47.88	74.00	-26.12	peak
N/A						

Remark:

1. Measuring frequencies from 1 GHz to the 10th harmonic of highest fundamental frequency.
2. For above 1GHz, the EUT peak value was under average limit, therefore the Average value compliance with the average limit

Test Mode	IEEE 802.11a Low CH	Temp/Hum	24(°C)/ 33%RH
Test Item	Harmonic	Test Date	December 2, 2017
Polarize	Horizontal	Test Engineer	Kevin Kuo
Detector	Peak and Average		

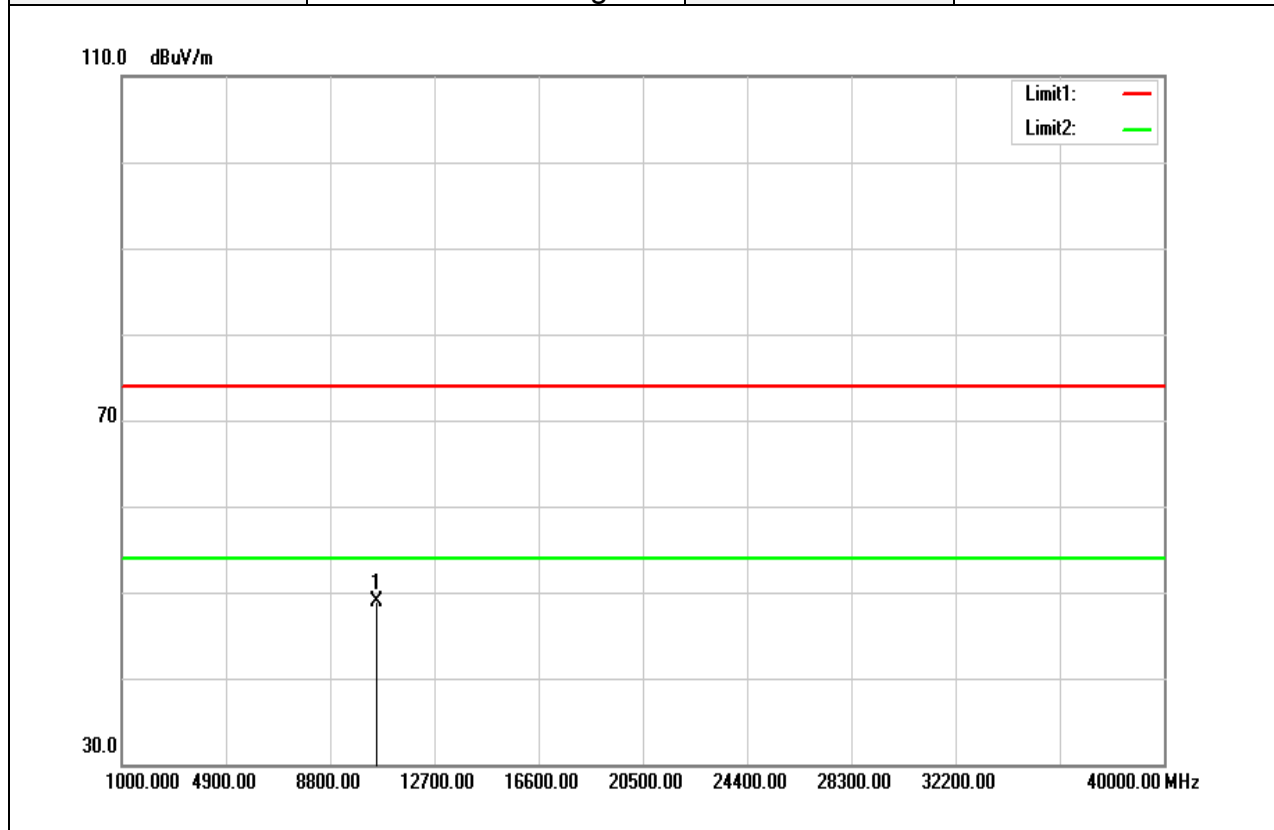

Frequency (MHz)	Reading (dBuV)	Correct Factor (dB/m)	Result (dBuV/m)	Limit (dBuV/m)	Margin (dB)	Remark
10520.000	33.95	14.97	48.92	74.00	-25.08	peak
N/A						

Remark:

1. Measuring frequencies from 1 GHz to the 10th harmonic of highest fundamental frequency.
2. For above 1GHz, the EUT peak value was under average limit, therefore the Average value compliance with the average limit

Test Mode	IEEE 802.11a Mid CH	Temp/Hum	24(°C)/ 33%RH
Test Item	Harmonic	Test Date	December 2, 2017
Polarize	Vertical	Test Engineer	Kevin Kuo
Detector	Peak and Average		

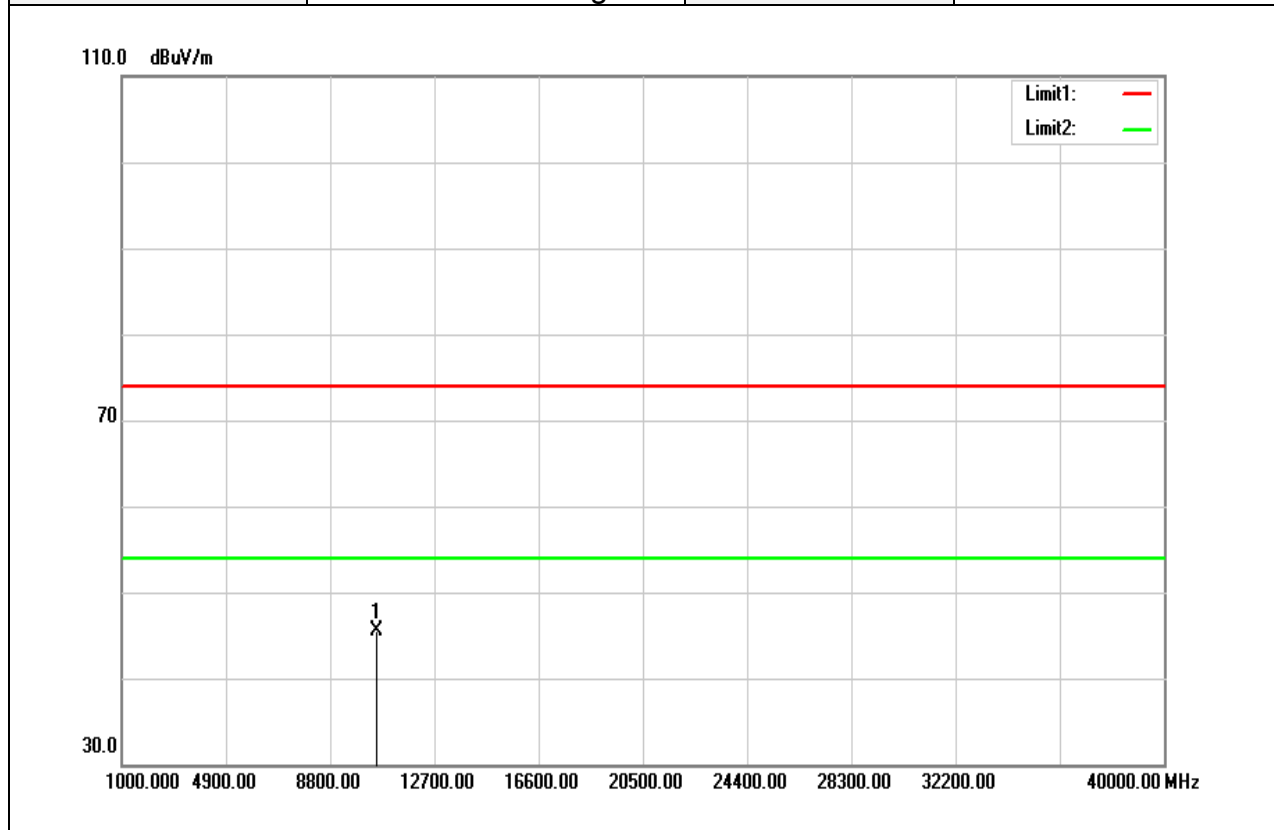

Frequency (MHz)	Reading (dBuV)	Correct Factor (dB/m)	Result (dBuV/m)	Limit (dBuV/m)	Margin (dB)	Remark
10560.000	30.49	15.06	45.55	74.00	-28.45	peak
N/A						

Remark:

1. Measuring frequencies from 1 GHz to the 10th harmonic of highest fundamental frequency.
2. For above 1GHz, the EUT peak value was under average limit, therefore the Average value compliance with the average limit

Test Mode	IEEE 802.11a Mid CH	Temp/Hum	24(°C)/ 33%RH
Test Item	Harmonic	Test Date	December 2, 2017
Polarize	Horizontal	Test Engineer	Kevin Kuo
Detector	Peak and Average		

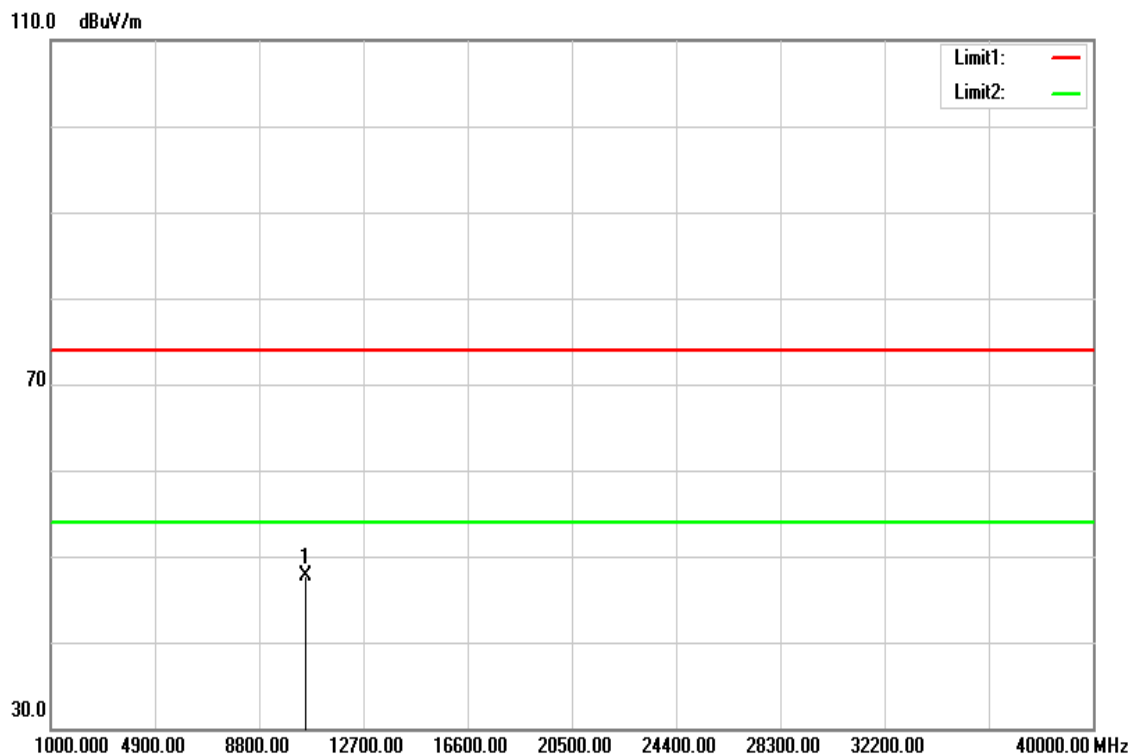

Frequency (MHz)	Reading (dBuV)	Correct Factor (dB/m)	Result (dBuV/m)	Limit (dBuV/m)	Margin (dB)	Remark
10560.000	32.72	15.06	47.78	74.00	-26.22	peak
N/A						

Remark:

1. Measuring frequencies from 1 GHz to the 10th harmonic of highest fundamental frequency.
2. For above 1GHz, the EUT peak value was under average limit, therefore the Average value compliance with the average limit

Test Mode	IEEE 802.11a High CH	Temp/Hum	24(°C)/ 33%RH
Test Item	Harmonic	Test Date	December 2, 2017
Polarize	Vertical	Test Engineer	Kevin Kuo
Detector	Peak and Average		

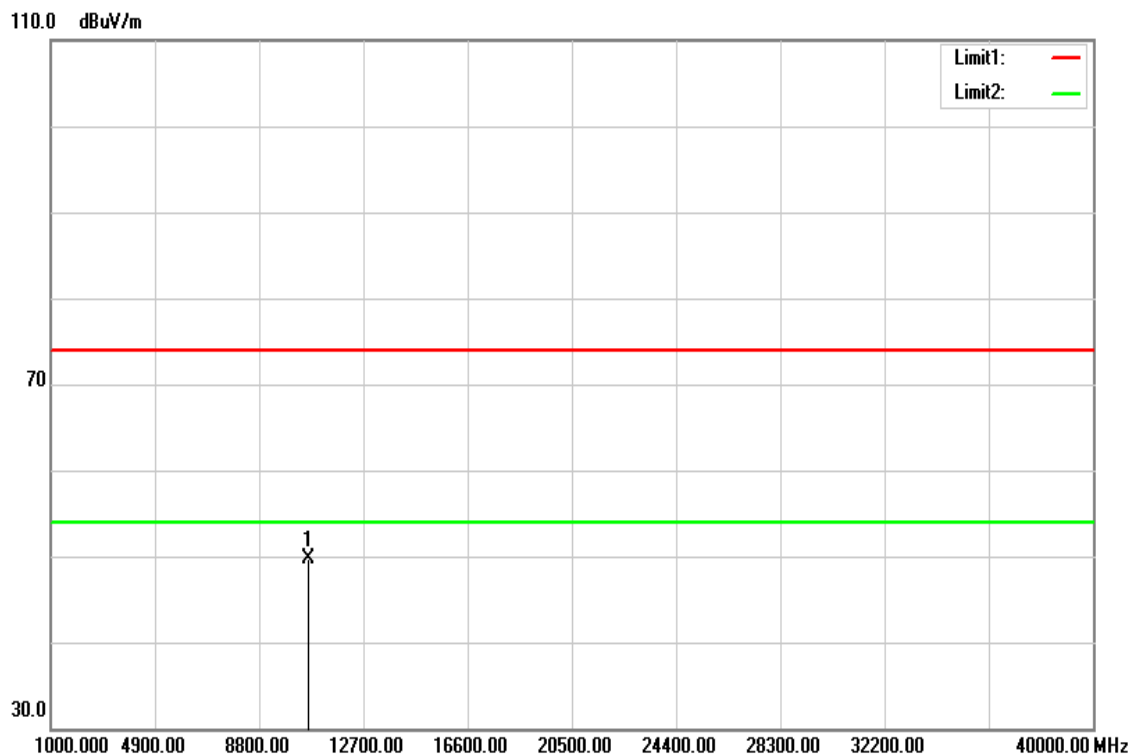

Frequency (MHz)	Reading (dBuV)	Correct Factor (dB/m)	Result (dBuV/m)	Limit (dBuV/m)	Margin (dB)	Remark
10640.000	34.44	15.23	49.67	74.00	-24.33	peak
N/A						

Remark:

1. Measuring frequencies from 1 GHz to the 10th harmonic of highest fundamental frequency.
2. For above 1GHz, the EUT peak value was under average limit, therefore the Average value compliance with the average limit

Test Mode	IEEE 802.11a High CH	Temp/Hum	24(°C)/ 33%RH
Test Item	Harmonic	Test Date	December 2, 2017
Polarize	Horizontal	Test Engineer	Kevin Kuo
Detector	Peak and Average		

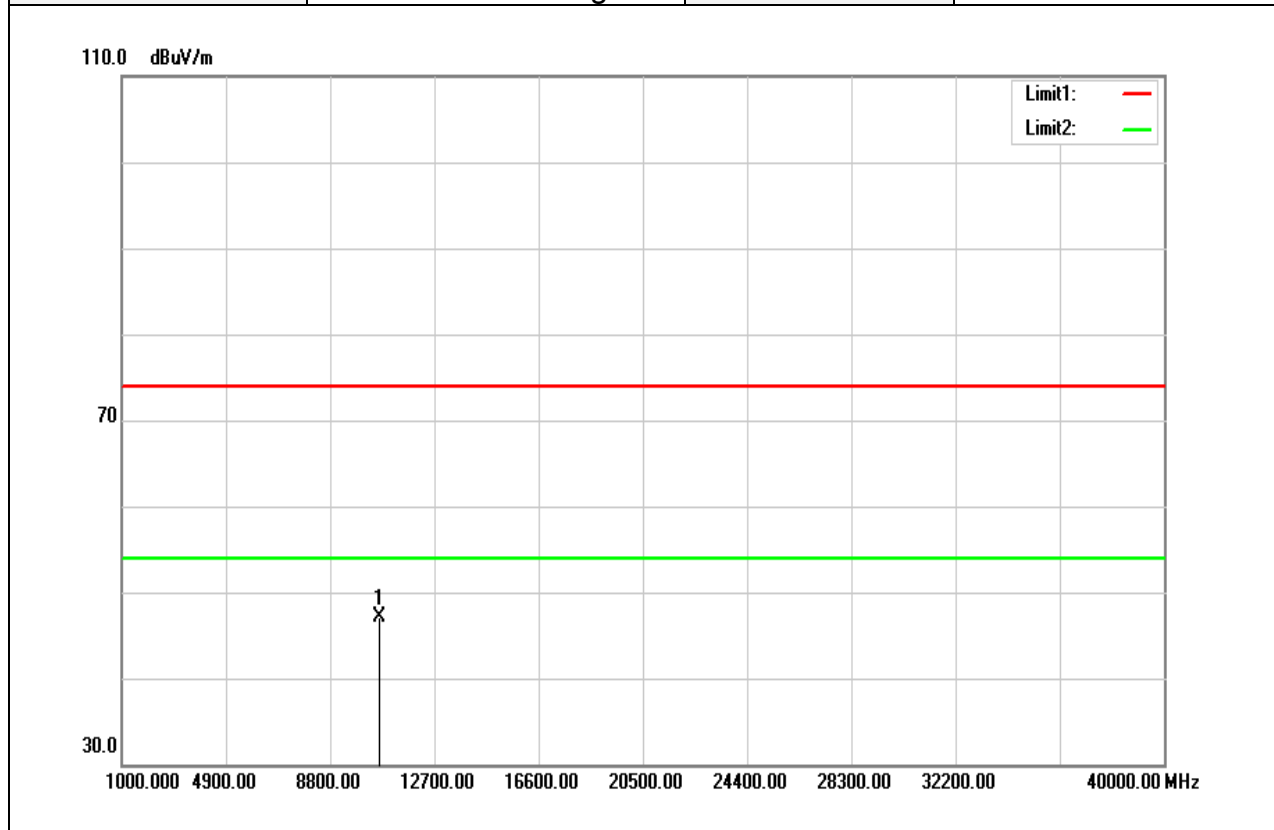

Frequency (MHz)	Reading (dBuV)	Correct Factor (dB/m)	Result (dBuV/m)	Limit (dBuV/m)	Margin (dB)	Remark
10640.000	31.92	15.23	47.15	74.00	-26.85	peak
N/A						

Remark:

1. Measuring frequencies from 1 GHz to the 10th harmonic of highest fundamental frequency.
2. For above 1GHz, the EUT peak value was under average limit, therefore the Average value compliance with the average limit

Test Mode	IEEE 802.11n HT20 Low CH	Temp/Hum	24(°C)/ 33%RH
Test Item	Harmonic	Test Date	December 2, 2017
Polarize	Vertical	Test Engineer	Kevin Kuo
Detector	Peak and Average		

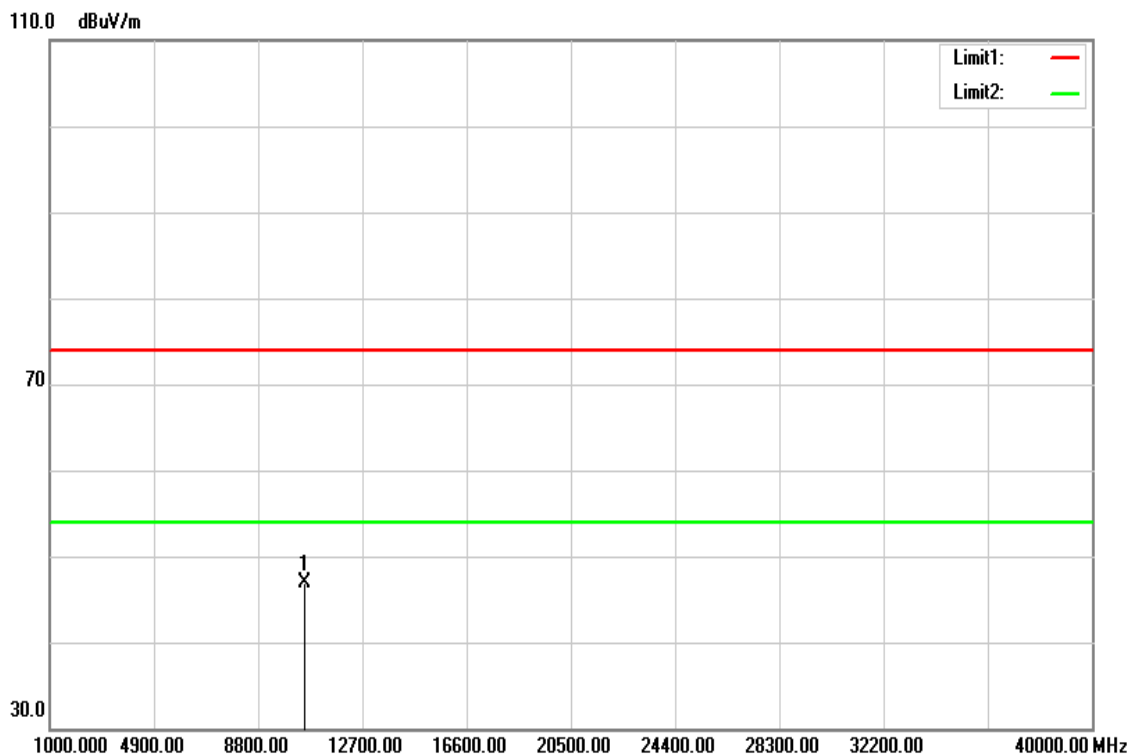

Frequency (MHz)	Reading (dBuV)	Correct Factor (dB/m)	Result (dBuV/m)	Limit (dBuV/m)	Margin (dB)	Remark
10520.000	31.93	14.97	46.90	74.00	-27.10	peak
N/A						

Remark:

1. Measuring frequencies from 1 GHz to the 10th harmonic of highest fundamental frequency.
2. For above 1GHz, the EUT peak value was under average limit, therefore the Average value compliance with the average limit

Test Mode	IEEE 802.11n HT20 Low CH	Temp/Hum	24(°C)/ 33%RH
Test Item	Harmonic	Test Date	December 2, 2017
Polarize	Horizontal	Test Engineer	Kevin Kuo
Detector	Peak and Average		

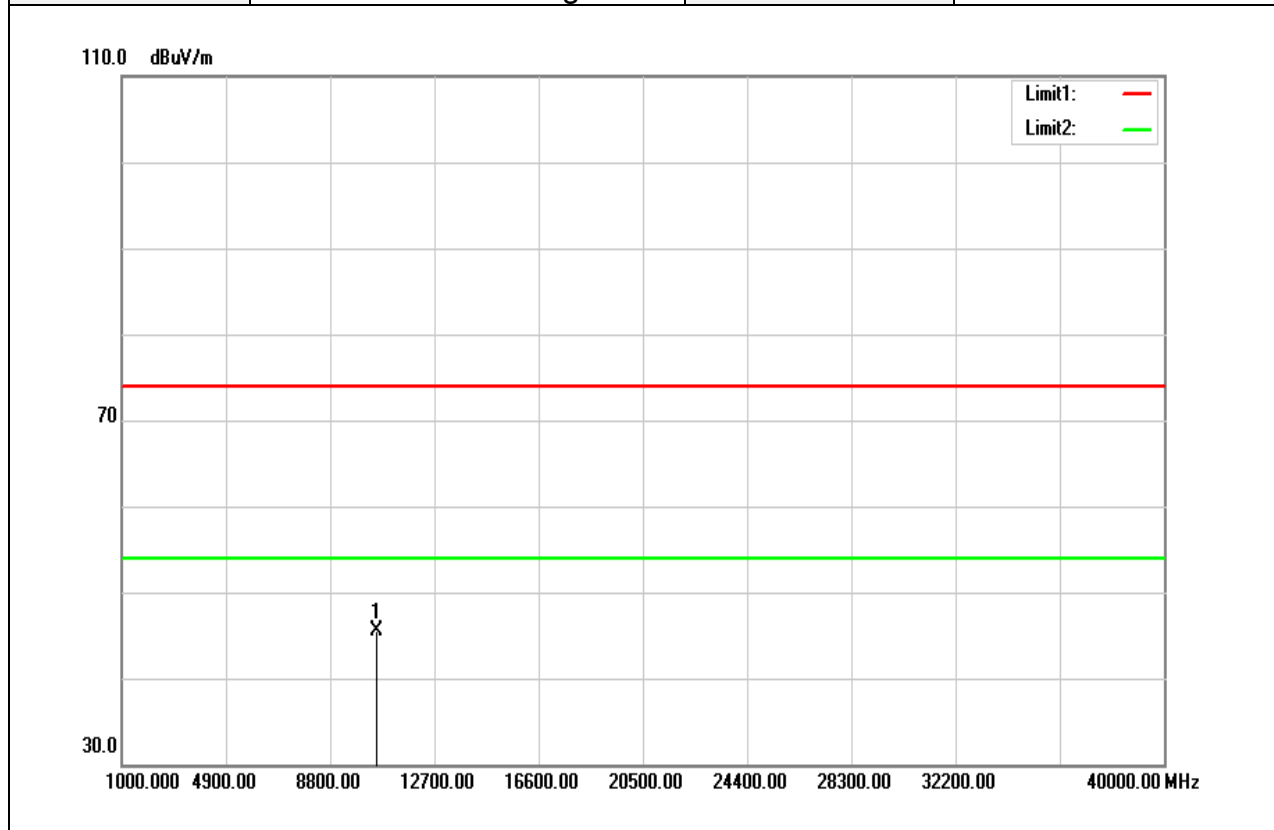

Frequency (MHz)	Reading (dBuV)	Correct Factor (dB/m)	Result (dBuV/m)	Limit (dBuV/m)	Margin (dB)	Remark
10520.000	30.51	14.97	45.48	74.00	-28.52	peak
N/A						

Remark:

1. Measuring frequencies from 1 GHz to the 10th harmonic of highest fundamental frequency.
2. For above 1GHz, the EUT peak value was under average limit, therefore the Average value compliance with the average limit

Test Mode	IEEE 802.11n HT20 Mid CH	Temp/Hum	24(°C)/ 33%RH
Test Item	Harmonic	Test Date	December 2, 2017
Polarize	Vertical	Test Engineer	Kevin Kuo
Detector	Peak and Average		

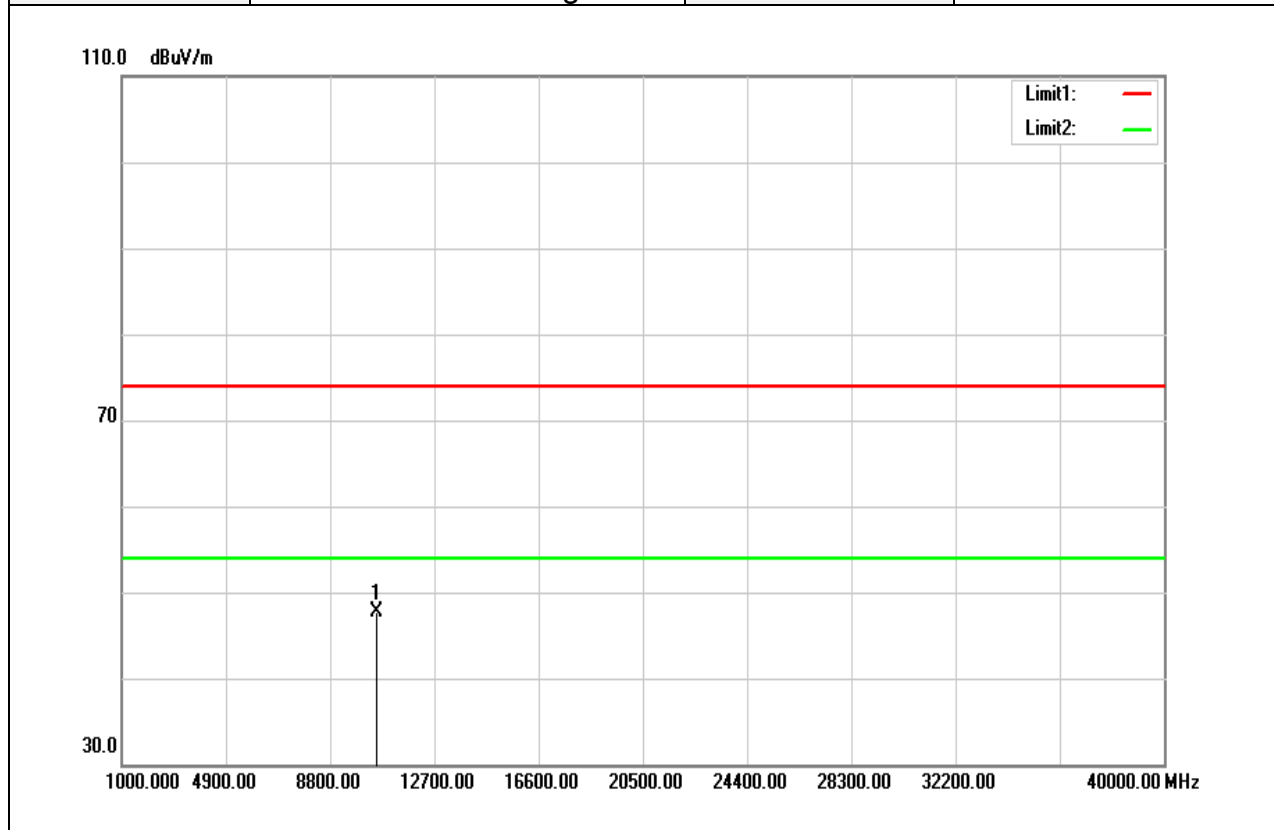

Frequency (MHz)	Reading (dBuV)	Correct Factor (dB/m)	Result (dBuV/m)	Limit (dBuV/m)	Margin (dB)	Remark
10560.000	32.67	15.06	47.73	74.00	-26.27	peak
N/A						

Remark:

1. Measuring frequencies from 1 GHz to the 10th harmonic of highest fundamental frequency.
2. For above 1GHz, the EUT peak value was under average limit, therefore the Average value compliance with the average limit

Test Mode	IEEE 802.11n HT20 Mid CH	Temp/Hum	24(°C)/ 33%RH
Test Item	Harmonic	Test Date	December 2, 2017
Polarize	Horizontal	Test Engineer	Kevin Kuo
Detector	Peak and Average		

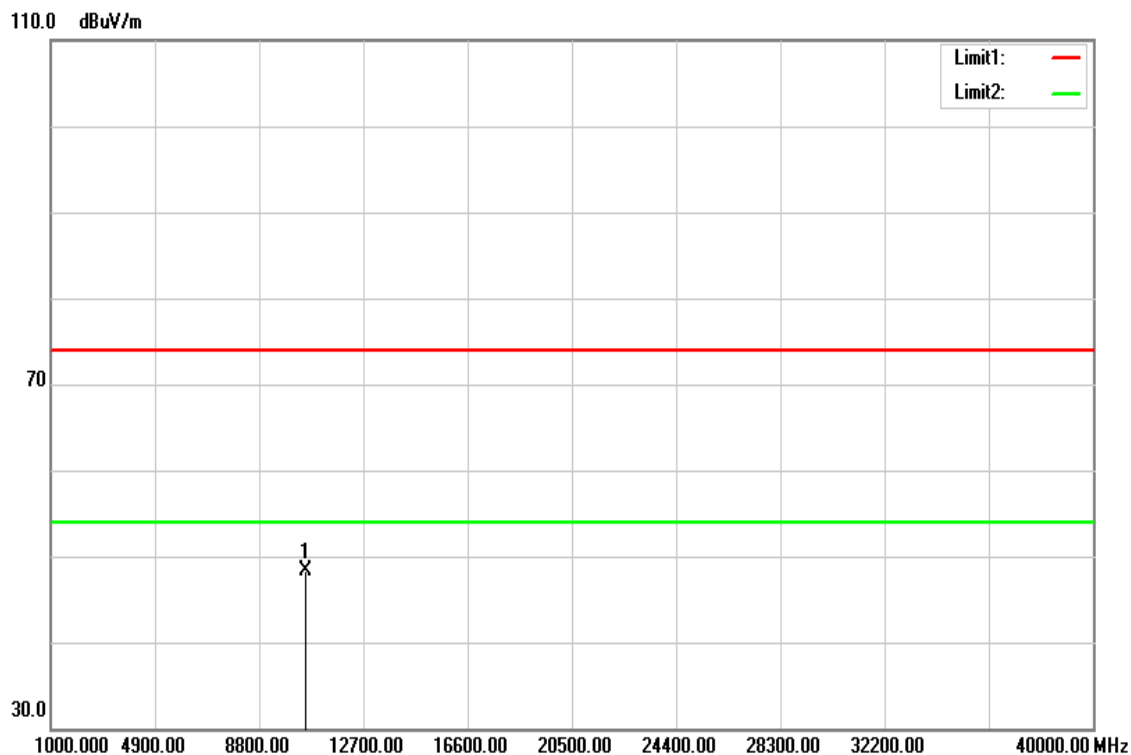

Frequency (MHz)	Reading (dBuV)	Correct Factor (dB/m)	Result (dBuV/m)	Limit (dBuV/m)	Margin (dB)	Remark
10560.000	33.19	15.06	48.25	74.00	-25.75	peak
N/A						

Remark:

1. Measuring frequencies from 1 GHz to the 10th harmonic of highest fundamental frequency.
2. For above 1GHz, the EUT peak value was under average limit, therefore the Average value compliance with the average limit

Test Mode	IEEE 802.11n HT20 High CH	Temp/Hum	24(°C)/ 33%RH
Test Item	Harmonic	Test Date	December 2, 2017
Polarize	Vertical	Test Engineer	Kevin Kuo
Detector	Peak and Average		

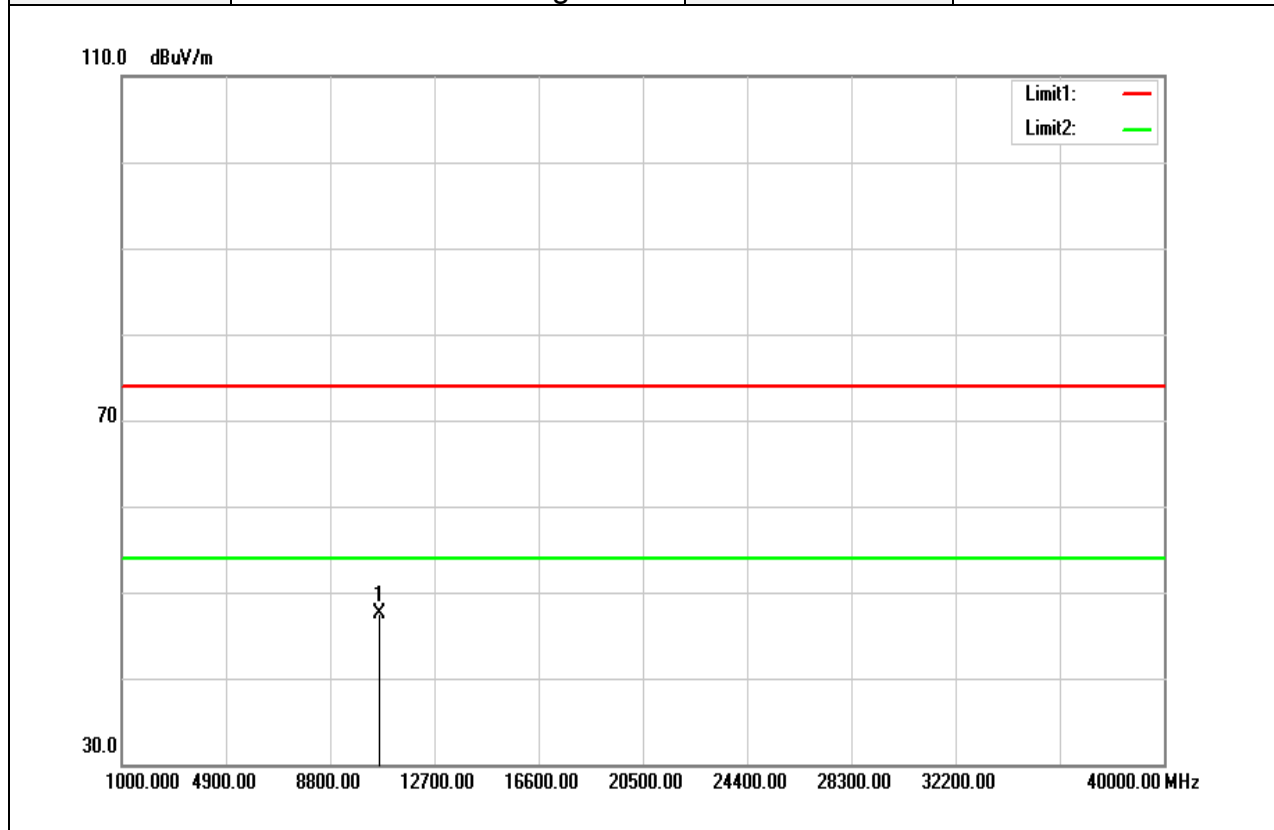

Frequency (MHz)	Reading (dBuV)	Correct Factor (dB/m)	Result (dBuV/m)	Limit (dBuV/m)	Margin (dB)	Remark
10640.000	32.32	15.23	47.55	74.00	-26.45	peak
N/A						

Remark:

1. Measuring frequencies from 1 GHz to the 10th harmonic of highest fundamental frequency.
2. For above 1GHz, the EUT peak value was under average limit, therefore the Average value compliance with the average limit

Test Mode	IEEE 802.11n HT20 High CH	Temp/Hum	24(°C)/ 33%RH
Test Item	Harmonic	Test Date	December 2, 2017
Polarize	Horizontal	Test Engineer	Kevin Kuo
Detector	Peak and Average		

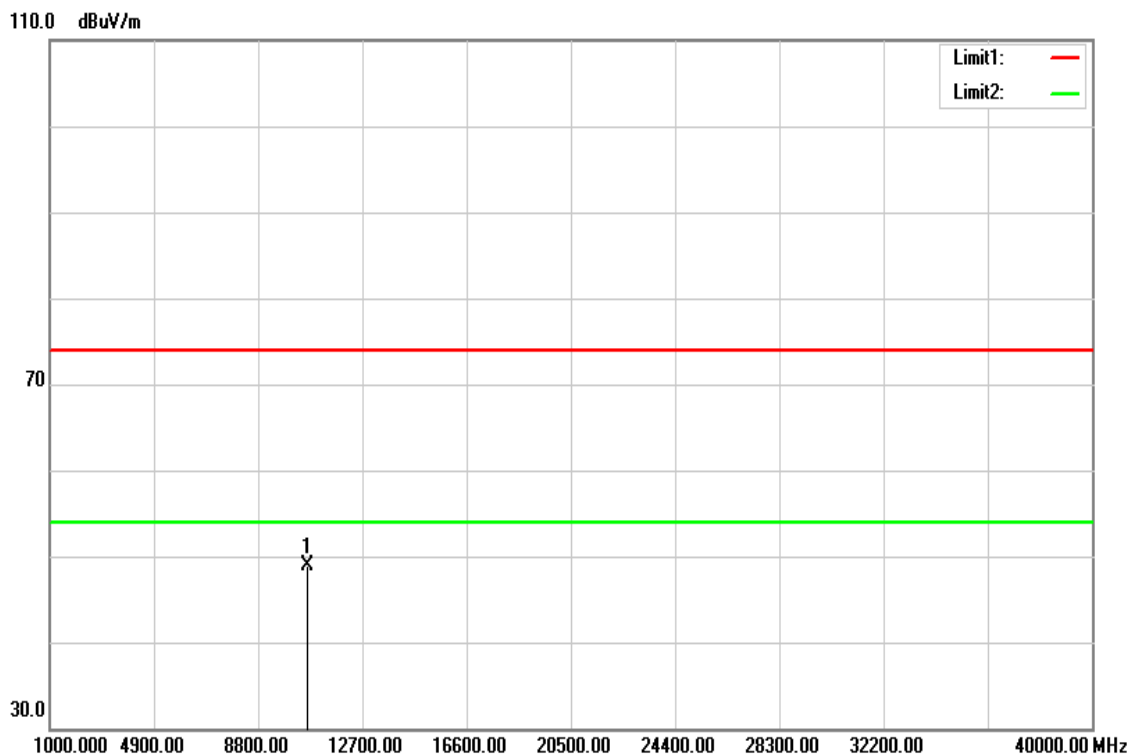

Frequency (MHz)	Reading (dBuV)	Correct Factor (dB/m)	Result (dBuV/m)	Limit (dBuV/m)	Margin (dB)	Remark
10640.000	33.63	15.23	48.86	74.00	-25.14	peak
N/A						

Remark:

1. Measuring frequencies from 1 GHz to the 10th harmonic of highest fundamental frequency.
2. For above 1GHz, the EUT peak value was under average limit, therefore the Average value compliance with the average limit

Test Mode	IEEE 802.11n HT40 Low CH	Temp/Hum	24(°C)/ 33%RH
Test Item	Harmonic	Test Date	December 2, 2017
Polarize	Vertical	Test Engineer	Kevin Kuo
Detector	Peak and Average		

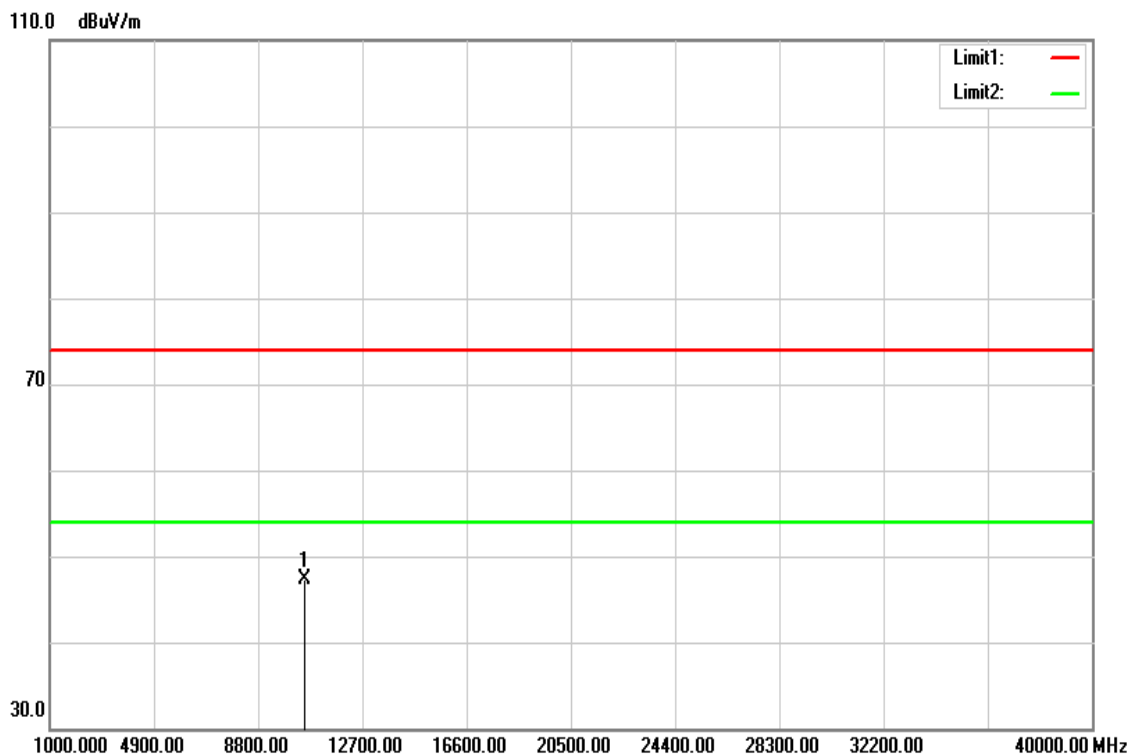

Frequency (MHz)	Reading (dBuV)	Correct Factor (dB/m)	Result (dBuV/m)	Limit (dBuV/m)	Margin (dB)	Remark
10540.000	32.33	15.01	47.34	74.00	-26.66	peak
N/A						

Remark:

1. Measuring frequencies from 1 GHz to the 10th harmonic of highest fundamental frequency.
2. For above 1GHz, the EUT peak value was under average limit, therefore the Average value compliance with the average limit

Test Mode	IEEE 802.11n HT40 Low CH	Temp/Hum	24(°C)/ 33%RH
Test Item	Harmonic	Test Date	December 2, 2017
Polarize	Horizontal	Test Engineer	Kevin Kuo
Detector	Peak and Average		

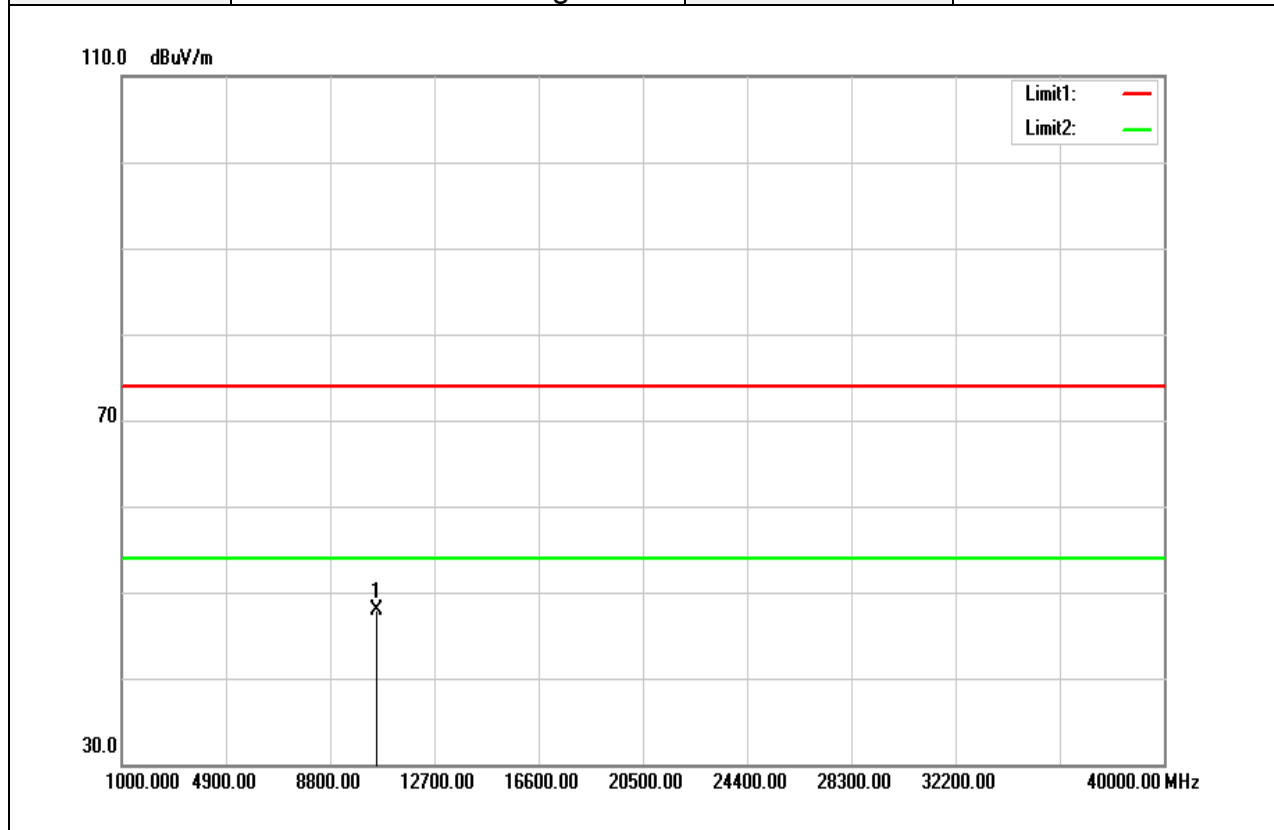

Frequency (MHz)	Reading (dBuV)	Correct Factor (dB/m)	Result (dBuV/m)	Limit (dBuV/m)	Margin (dB)	Remark
10540.000	32.96	15.01	47.97	74.00	-26.03	peak
N/A						

Remark:

1. Measuring frequencies from 1 GHz to the 10th harmonic of highest fundamental frequency.
2. For above 1GHz, the EUT peak value was under average limit, therefore the Average value compliance with the average limit

Test Mode	IEEE 802.11n HT40 High CH	Temp/Hum	24(°C)/ 33%RH
Test Item	Harmonic	Test Date	December 2, 2017
Polarize	Vertical	Test Engineer	Kevin Kuo
Detector	Peak and Average		

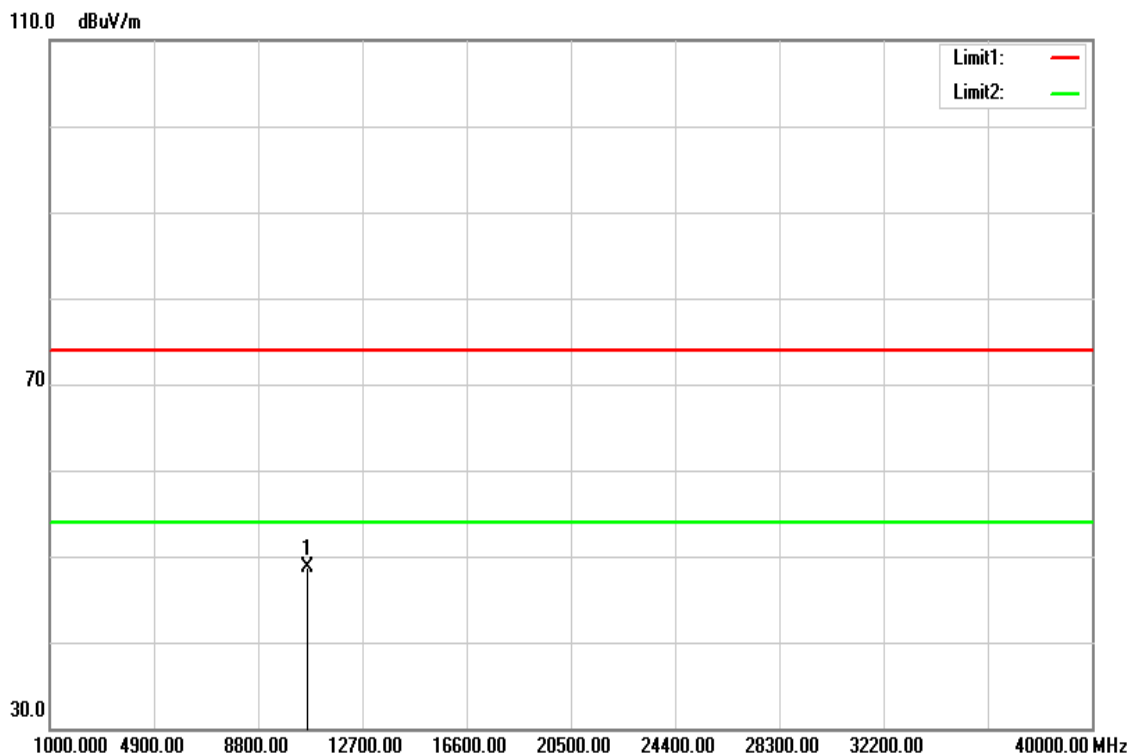

Frequency (MHz)	Reading (dBuV)	Correct Factor (dB/m)	Result (dBuV/m)	Limit (dBuV/m)	Margin (dB)	Remark
10620.000	33.41	15.20	48.61	74.00	-25.39	peak
N/A						

Remark:

1. Measuring frequencies from 1 GHz to the 10th harmonic of highest fundamental frequency.
2. For above 1GHz, the EUT peak value was under average limit, therefore the Average value compliance with the average limit

Test Mode	IEEE 802.11n HT40 High CH	Temp/Hum	24(°C)/ 33%RH
Test Item	Harmonic	Test Date	December 2, 2017
Polarize	Horizontal	Test Engineer	Kevin Kuo
Detector	Peak and Average		

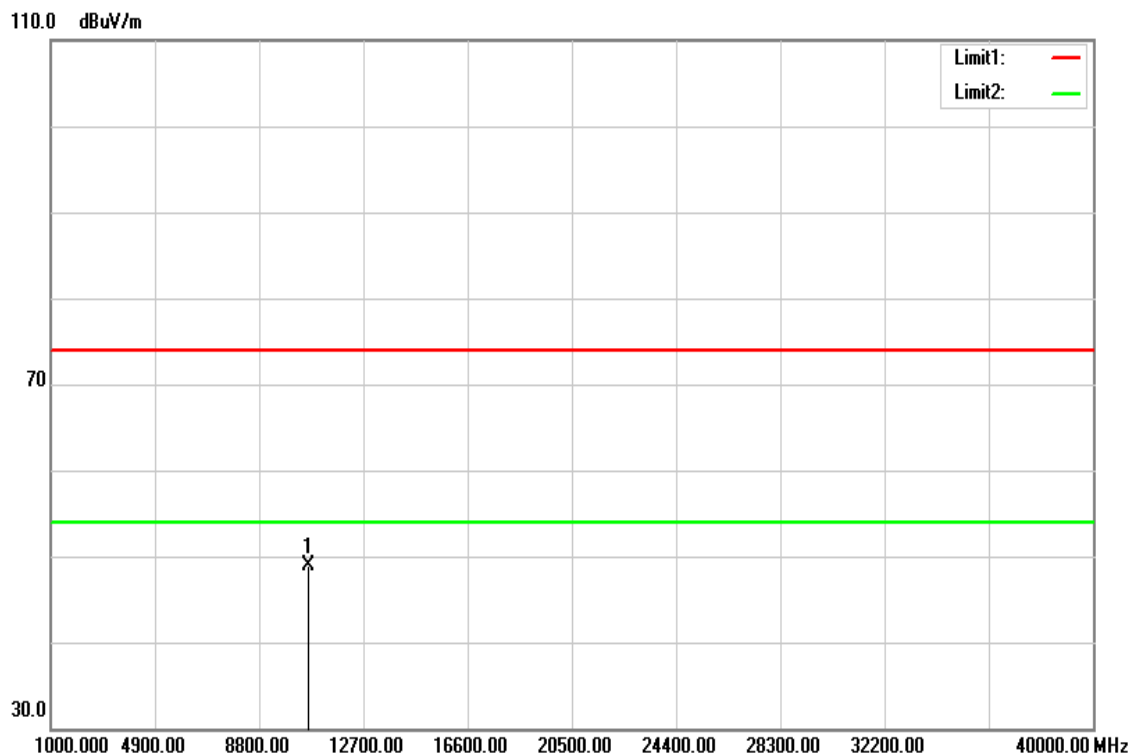

Frequency (MHz)	Reading (dBuV)	Correct Factor (dB/m)	Result (dBuV/m)	Limit (dBuV/m)	Margin (dB)	Remark
10620.000	33.71	15.20	48.91	74.00	-25.09	peak
N/A						

Remark:

1. Measuring frequencies from 1 GHz to the 10th harmonic of highest fundamental frequency.
2. For above 1GHz, the EUT peak value was under average limit, therefore the Average value compliance with the average limit

Above 1G Test Data for UNII-2c

Test Mode	IEEE 802.11a Low CH	Temp/Hum	24(°C)/ 33%RH
Test Item	Harmonic	Test Date	December 2, 2017
Polarize	Vertical	Test Engineer	Kevin Kuo
Detector	Peak and Average		

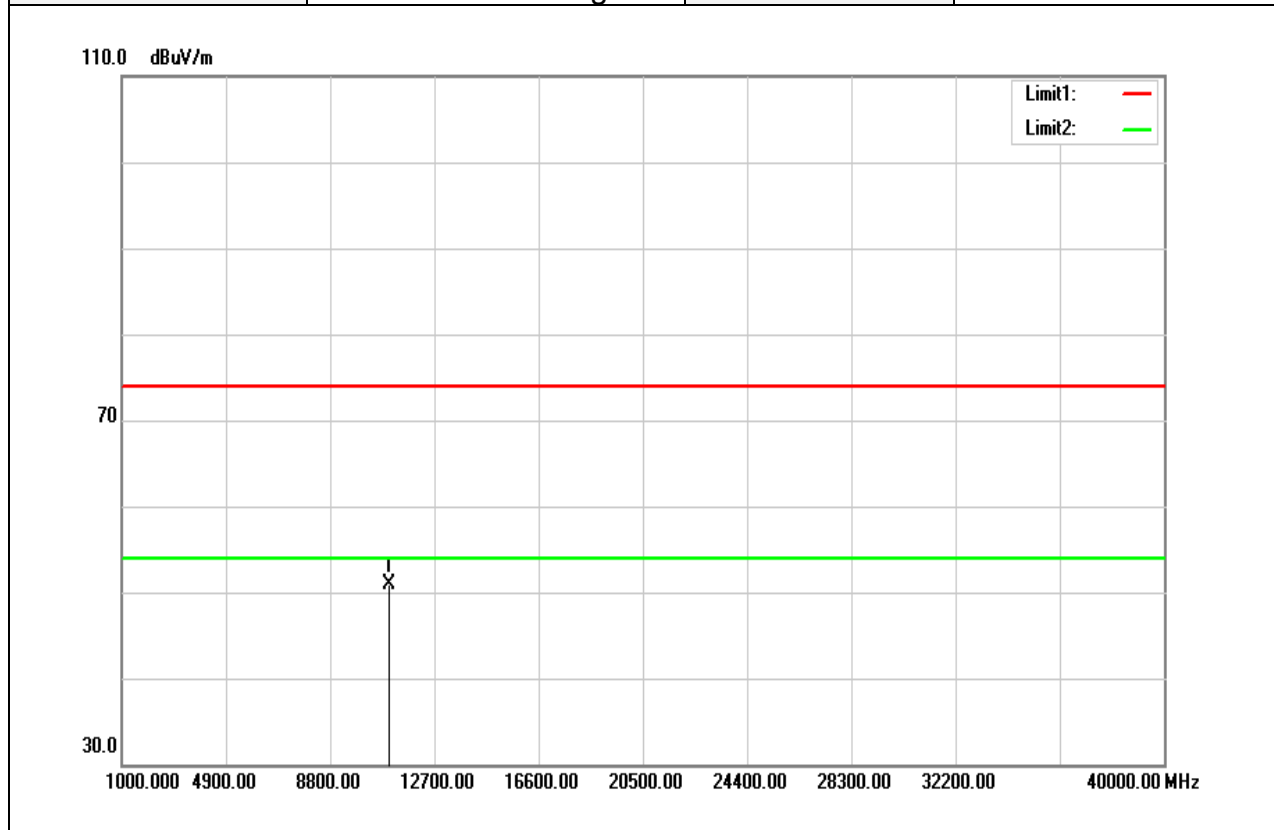

Frequency (MHz)	Reading (dBuV)	Correct Factor (dB/m)	Result (dBuV/m)	Limit (dBuV/m)	Margin (dB)	Remark
11000.000	34.93	16.06	50.99	74.00	-23.01	peak
N/A						

Remark:

1. Measuring frequencies from 1 GHz to the 10th harmonic of highest fundamental frequency.
2. For above 1GHz, the EUT peak value was under average limit, therefore the Average value compliance with the average limit

Test Mode	IEEE 802.11a Low CH	Temp/Hum	24(°C)/ 33%RH
Test Item	Harmonic	Test Date	December 2, 2017
Polarize	Horizontal	Test Engineer	Kevin Kuo
Detector	Peak and Average		

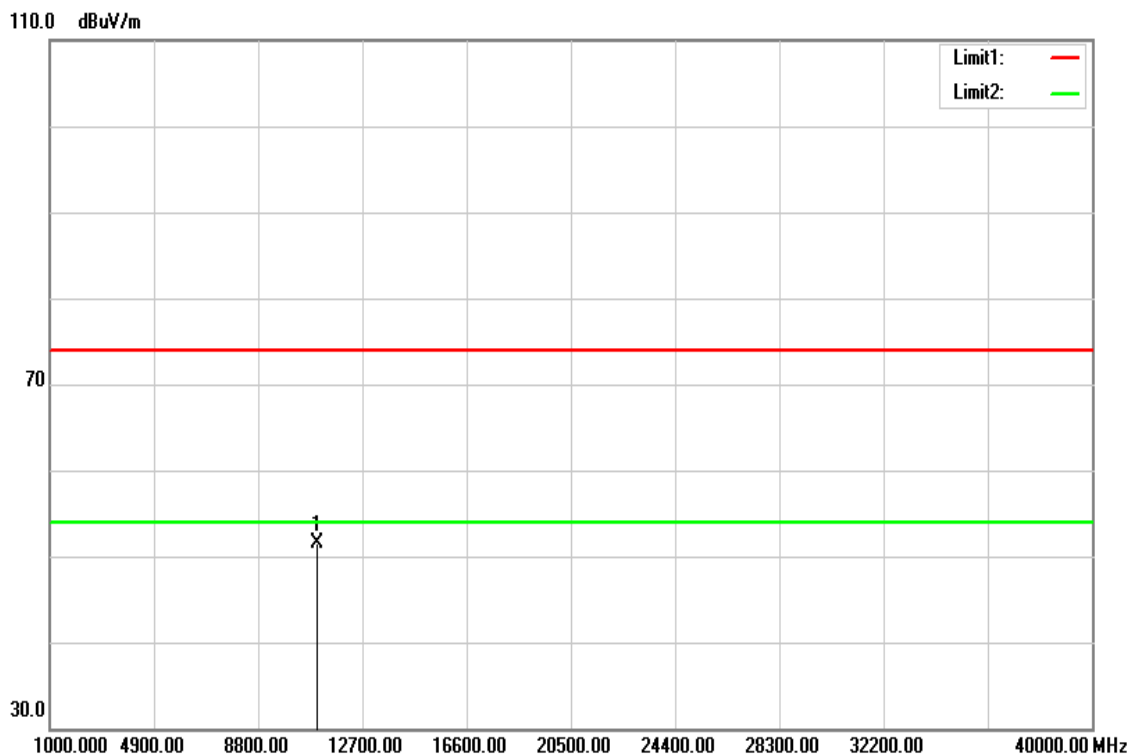

Frequency (MHz)	Reading (dBuV)	Correct Factor (dB/m)	Result (dBuV/m)	Limit (dBuV/m)	Margin (dB)	Remark
11000.000	35.44	16.06	51.50	74.00	-22.50	peak
N/A						

Remark:

1. Measuring frequencies from 1 GHz to the 10th harmonic of highest fundamental frequency.
2. For above 1GHz, the EUT peak value was under average limit, therefore the Average value compliance with the average limit

Test Mode	IEEE 802.11a Mid CH	Temp/Hum	24(°C)/ 33%RH
Test Item	Harmonic	Test Date	December 2, 2017
Polarize	Vertical	Test Engineer	Kevin Kuo
Detector	Peak and Average		

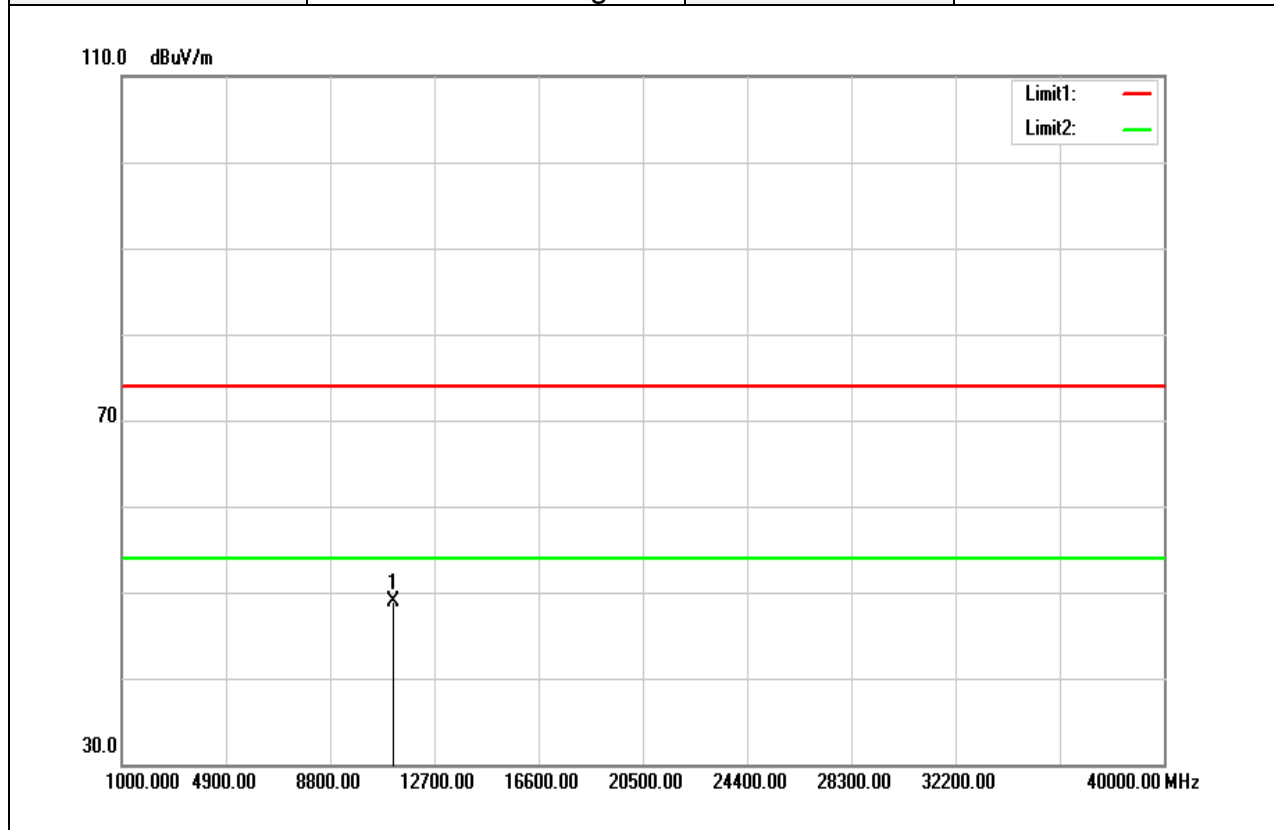

Frequency (MHz)	Reading (dBuV)	Correct Factor (dB/m)	Result (dBuV/m)	Limit (dBuV/m)	Margin (dB)	Remark
11160.000	32.92	16.07	48.99	74.00	-25.01	peak
N/A						

Remark:

1. Measuring frequencies from 1 GHz to the 10th harmonic of highest fundamental frequency.
2. For above 1GHz, the EUT peak value was under average limit, therefore the Average value compliance with the average limit

Test Mode	IEEE 802.11a Mid CH	Temp/Hum	24(°C)/ 33%RH
Test Item	Harmonic	Test Date	December 2, 2017
Polarize	Horizontal	Test Engineer	Kevin Kuo
Detector	Peak and Average		

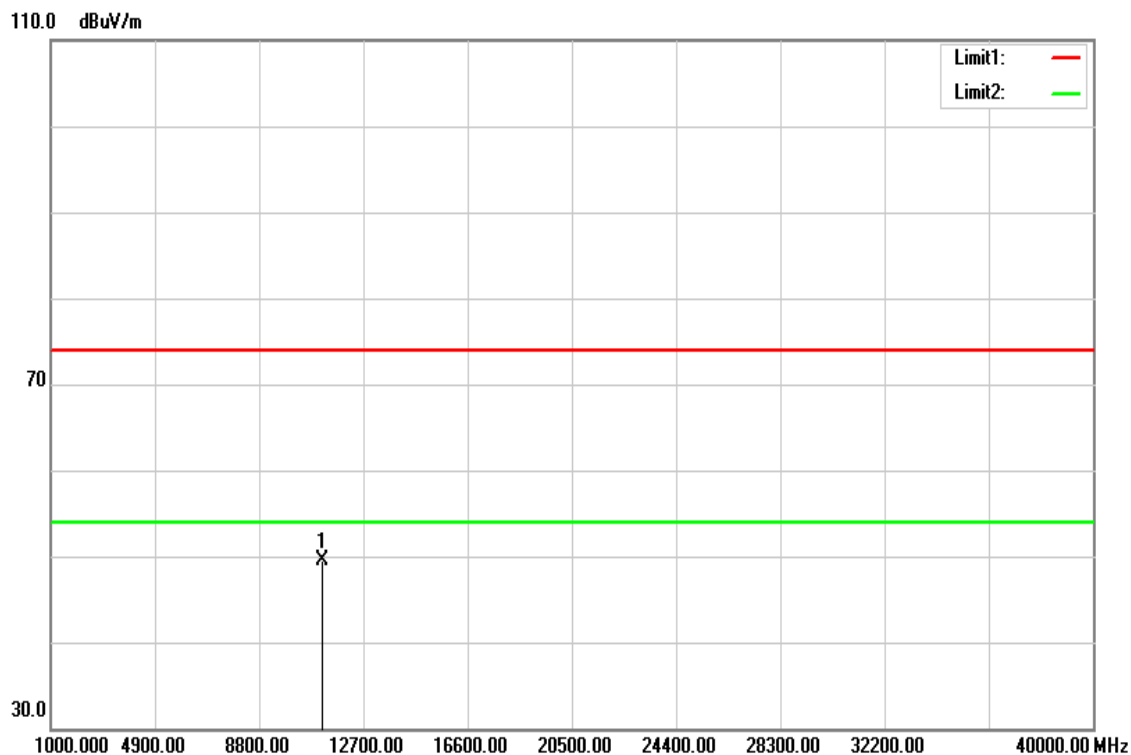

Frequency (MHz)	Reading (dBuV)	Correct Factor (dB/m)	Result (dBuV/m)	Limit (dBuV/m)	Margin (dB)	Remark
11160.000	33.47	16.07	49.54	74.00	-24.46	peak
N/A						

Remark:

1. Measuring frequencies from 1 GHz to the 10th harmonic of highest fundamental frequency.
2. For above 1GHz, the EUT peak value was under average limit, therefore the Average value compliance with the average limit

Test Mode	IEEE 802.11a High CH	Temp/Hum	24(°C)/ 33%RH
Test Item	Harmonic	Test Date	December 2, 2017
Polarize	Vertical	Test Engineer	Kevin Kuo
Detector	Peak and Average		

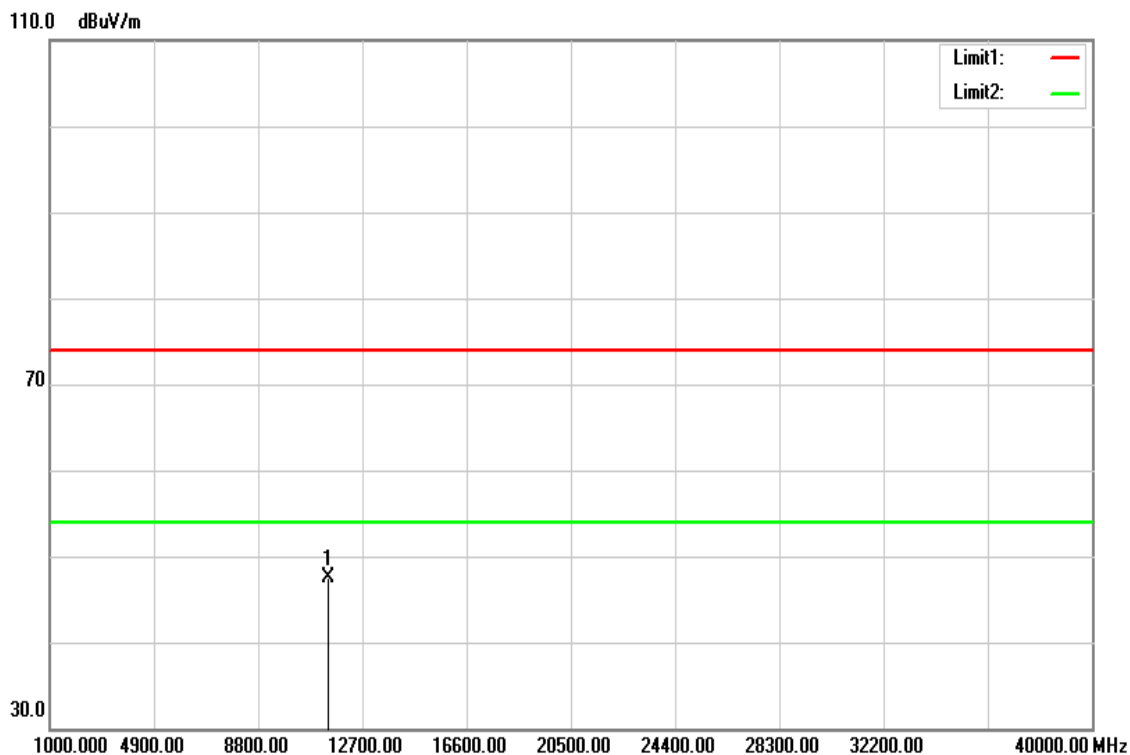

Frequency (MHz)	Reading (dBuV)	Correct Factor (dB/m)	Result (dBuV/m)	Limit (dBuV/m)	Margin (dB)	Remark
11400.000	31.52	16.08	47.60	74.00	-26.40	peak
N/A						

Remark:

1. Measuring frequencies from 1 GHz to the 10th harmonic of highest fundamental frequency.
2. For above 1GHz, the EUT peak value was under average limit, therefore the Average value compliance with the average limit

Test Mode	IEEE 802.11a High CH	Temp/Hum	24(°C)/ 33%RH
Test Item	Harmonic	Test Date	December 2, 2017
Polarize	Horizontal	Test Engineer	Kevin Kuo
Detector	Peak and Average		

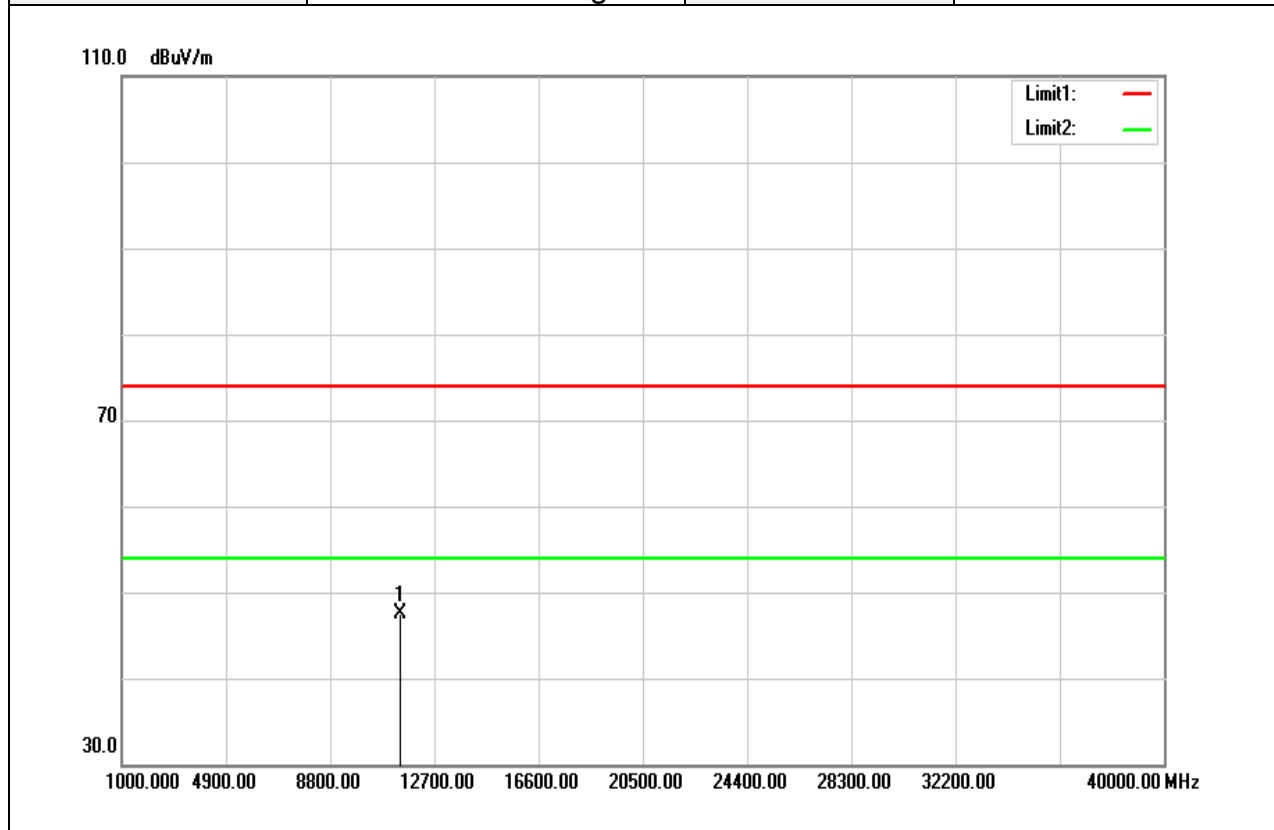

Frequency (MHz)	Reading (dBuV)	Correct Factor (dB/m)	Result (dBuV/m)	Limit (dBuV/m)	Margin (dB)	Remark
11400.000	31.34	16.08	47.42	74.00	-26.58	peak
N/A						

Remark:

1. Measuring frequencies from 1 GHz to the 10th harmonic of highest fundamental frequency.
2. For above 1GHz, the EUT peak value was under average limit, therefore the Average value compliance with the average limit

Test Mode	IEEE 802.11n HT20 Low CH	Temp/Hum	24(°C)/ 33%RH
Test Item	Harmonic	Test Date	December 2, 2017
Polarize	Vertical	Test Engineer	Kevin Kuo
Detector	Peak and Average		

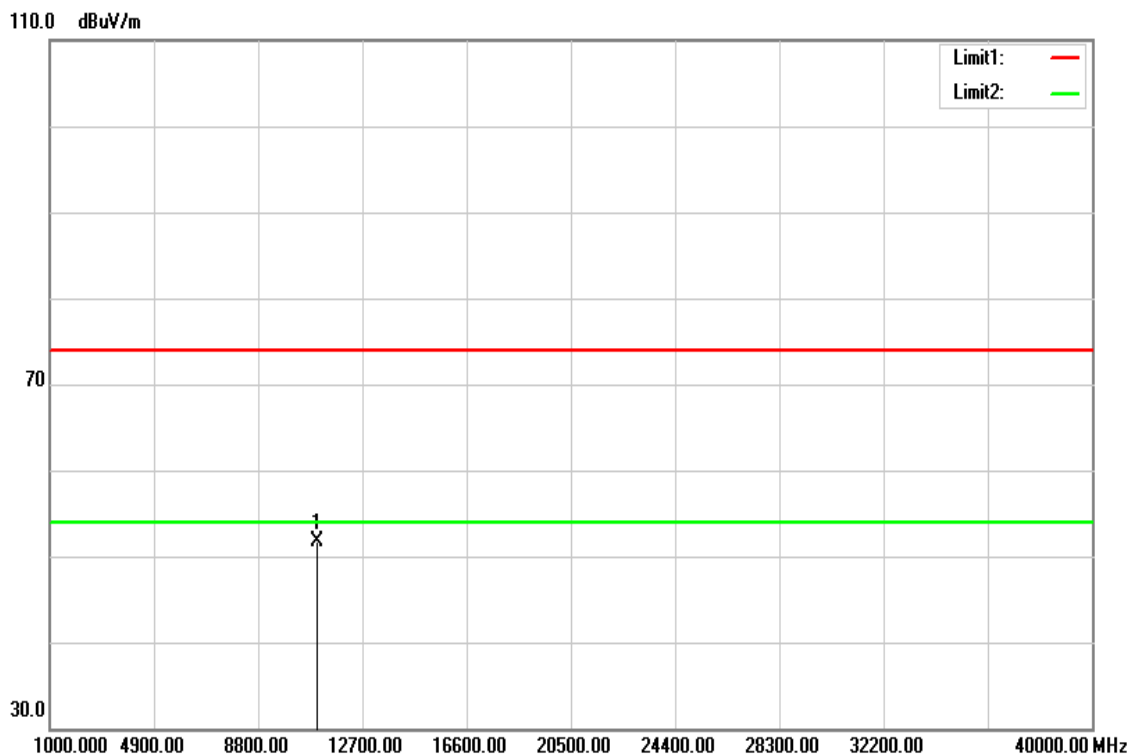

Frequency (MHz)	Reading (dBuV)	Correct Factor (dB/m)	Result (dBuV/m)	Limit (dBuV/m)	Margin (dB)	Remark
11000.000	35.57	16.06	51.63	74.00	-22.37	peak
N/A						

Remark:

1. Measuring frequencies from 1 GHz to the 10th harmonic of highest fundamental frequency.
2. For above 1GHz, the EUT peak value was under average limit, therefore the Average value compliance with the average limit

Test Mode	IEEE 802.11n HT20 Low CH	Temp/Hum	24(°C)/ 33%RH
Test Item	Harmonic	Test Date	December 2, 2017
Polarize	Horizontal	Test Engineer	Kevin Kuo
Detector	Peak and Average		

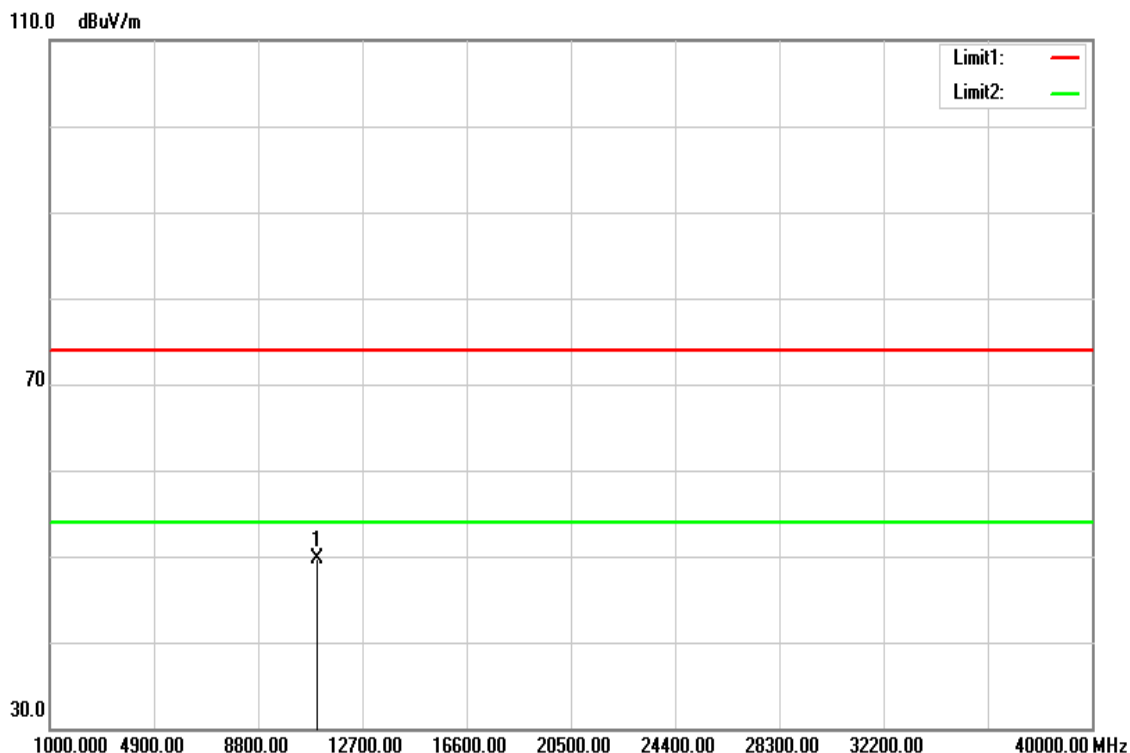

Frequency (MHz)	Reading (dBuV)	Correct Factor (dB/m)	Result (dBuV/m)	Limit (dBuV/m)	Margin (dB)	Remark
11000.000	33.58	16.06	49.64	74.00	-24.36	peak
N/A						

Remark:

1. Measuring frequencies from 1 GHz to the 10th harmonic of highest fundamental frequency.
2. For above 1GHz, the EUT peak value was under average limit, therefore the Average value compliance with the average limit

Test Mode	IEEE 802.11n HT20 Mid CH	Temp/Hum	24(°C)/ 33%RH
Test Item	Harmonic	Test Date	December 2, 2017
Polarize	Vertical	Test Engineer	Kevin Kuo
Detector	Peak and Average		

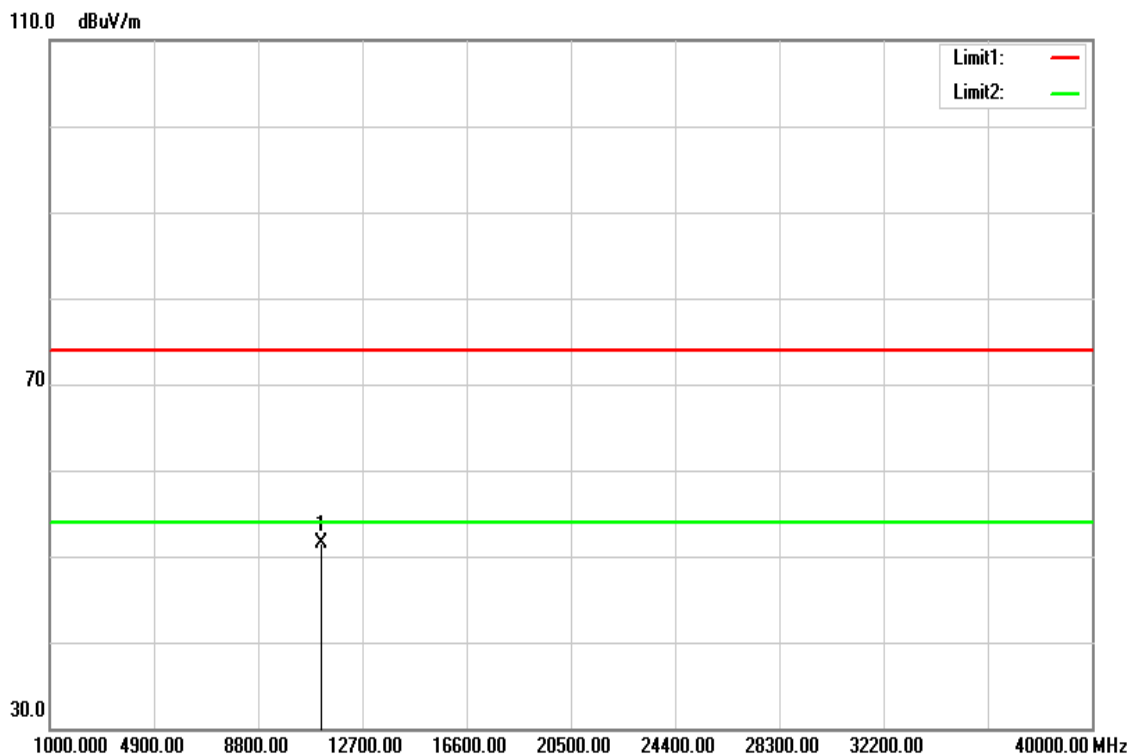

Frequency (MHz)	Reading (dBuV)	Correct Factor (dB/m)	Result (dBuV/m)	Limit (dBuV/m)	Margin (dB)	Remark
11160.000	35.50	16.07	51.57	74.00	-22.43	peak
N/A						

Remark:

1. Measuring frequencies from 1 GHz to the 10th harmonic of highest fundamental frequency.
2. For above 1GHz, the EUT peak value was under average limit, therefore the Average value compliance with the average limit

Test Mode	IEEE 802.11n HT20 Mid CH	Temp/Hum	24(°C)/ 33%RH
Test Item	Harmonic	Test Date	December 2, 2017
Polarize	Horizontal	Test Engineer	Kevin Kuo
Detector	Peak and Average		

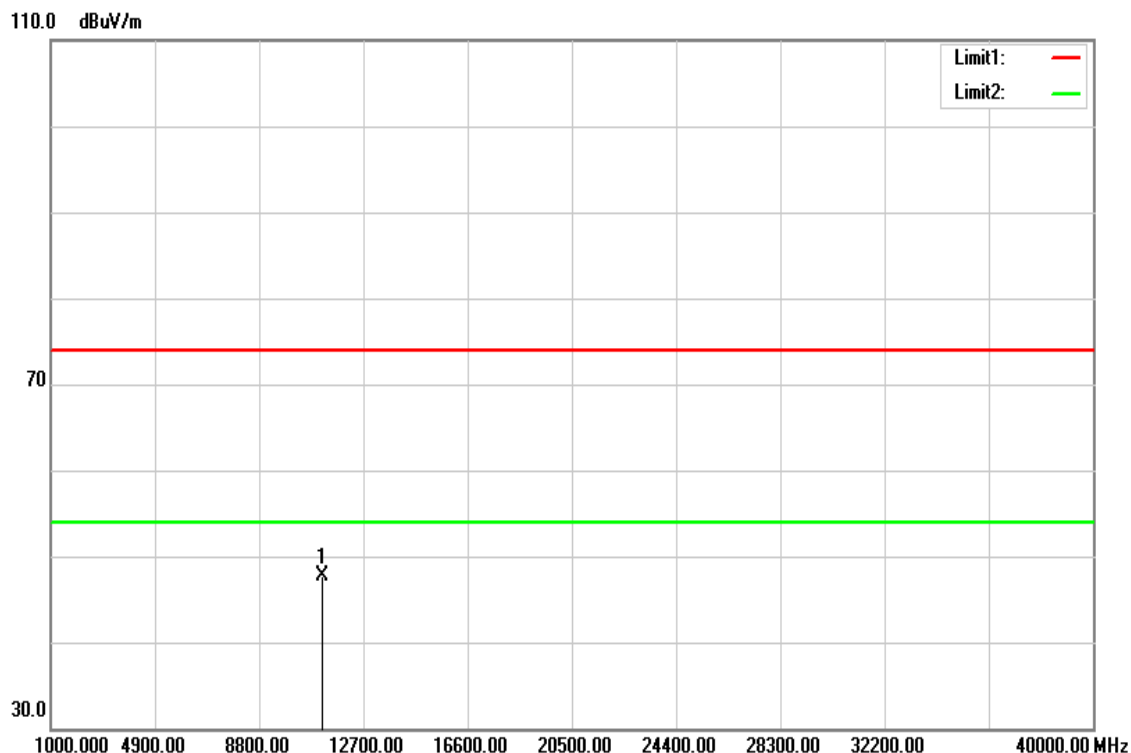

Frequency (MHz)	Reading (dBuV)	Correct Factor (dB/m)	Result (dBuV/m)	Limit (dBuV/m)	Margin (dB)	Remark
11160.000	31.67	16.07	47.74	74.00	-26.26	peak
N/A						

Remark:

1. Measuring frequencies from 1 GHz to the 10th harmonic of highest fundamental frequency.
2. For above 1GHz, the EUT peak value was under average limit, therefore the Average value compliance with the average limit

Test Mode	IEEE 802.11n HT20 High CH	Temp/Hum	24(°C)/ 33%RH
Test Item	Harmonic	Test Date	December 2, 2017
Polarize	Vertical	Test Engineer	Kevin Kuo
Detector	Peak and Average		

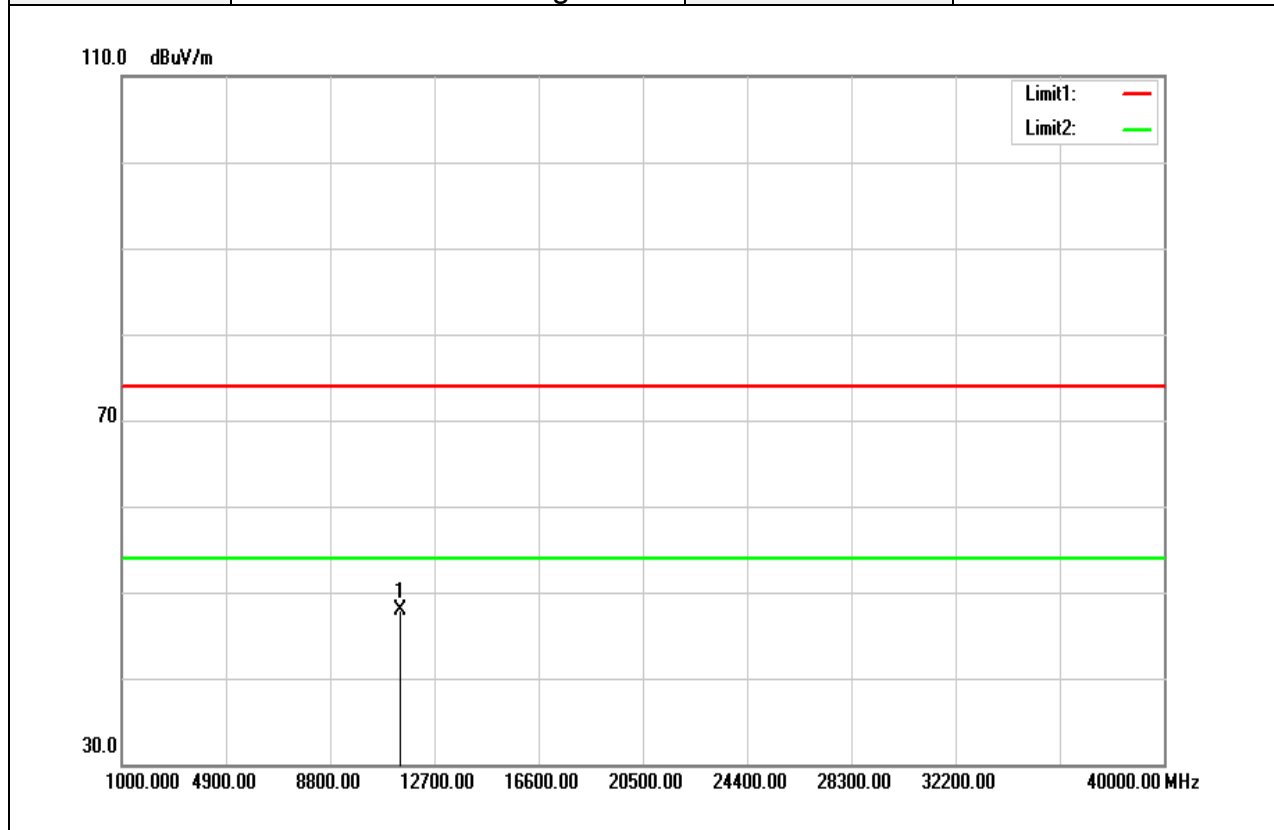

Frequency (MHz)	Reading (dBuV)	Correct Factor (dB/m)	Result (dBuV/m)	Limit (dBuV/m)	Margin (dB)	Remark
11400.000	31.84	16.08	47.92	74.00	-26.08	peak
N/A						

Remark:

1. Measuring frequencies from 1 GHz to the 10th harmonic of highest fundamental frequency.
2. For above 1GHz, the EUT peak value was under average limit, therefore the Average value compliance with the average limit

Test Mode	IEEE 802.11n HT20 High CH	Temp/Hum	24(°C)/ 33%RH
Test Item	Harmonic	Test Date	December 2, 2017
Polarize	Horizontal	Test Engineer	Kevin Kuo
Detector	Peak and Average		

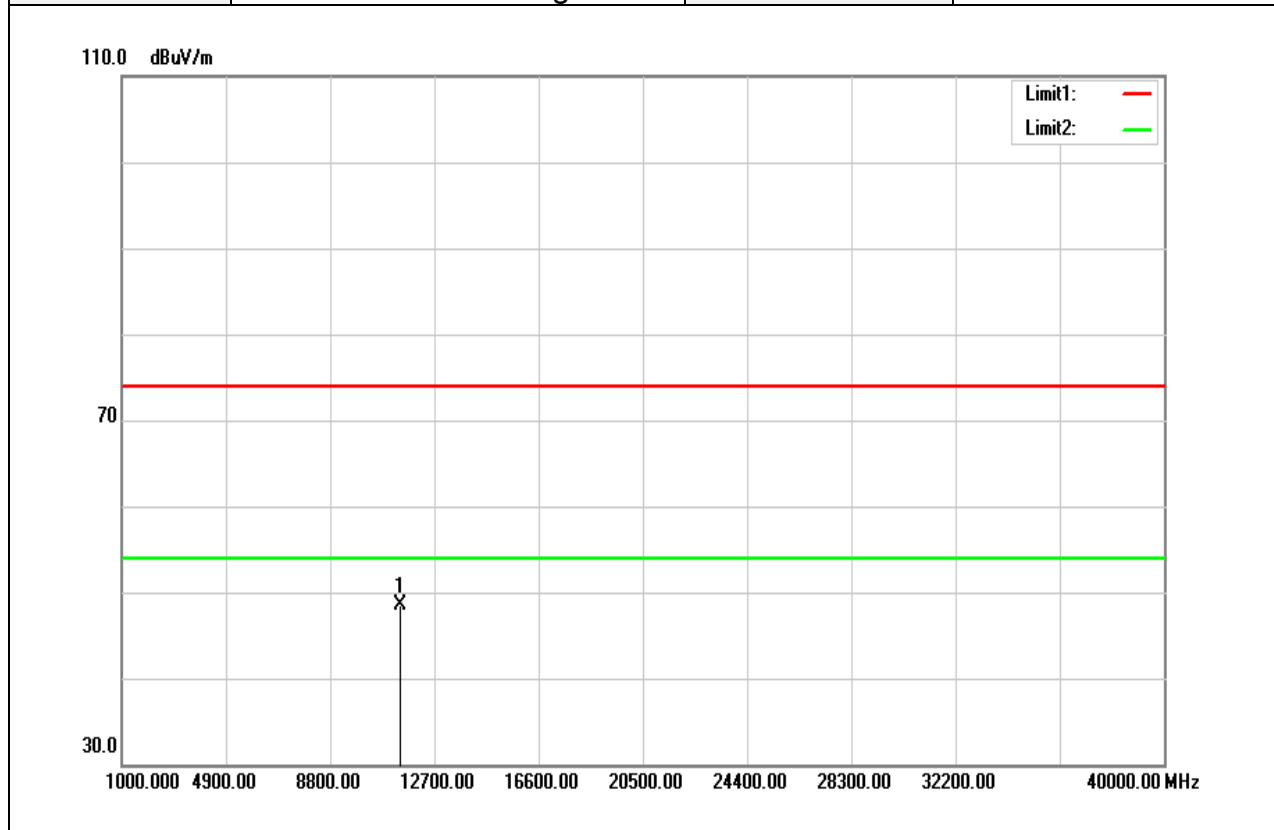

Frequency (MHz)	Reading (dBuV)	Correct Factor (dB/m)	Result (dBuV/m)	Limit (dBuV/m)	Margin (dB)	Remark
11400.000	32.38	16.08	48.46	74.00	-25.54	peak
N/A						

Remark:

1. Measuring frequencies from 1 GHz to the 10th harmonic of highest fundamental frequency.
2. For above 1GHz, the EUT peak value was under average limit, therefore the Average value compliance with the average limit

Test Mode	IEEE 802.11n HT40 Low CH	Temp/Hum	24(°C)/ 33%RH
Test Item	Harmonic	Test Date	December 2, 2017
Polarize	Vertical	Test Engineer	Kevin Kuo
Detector	Peak and Average		

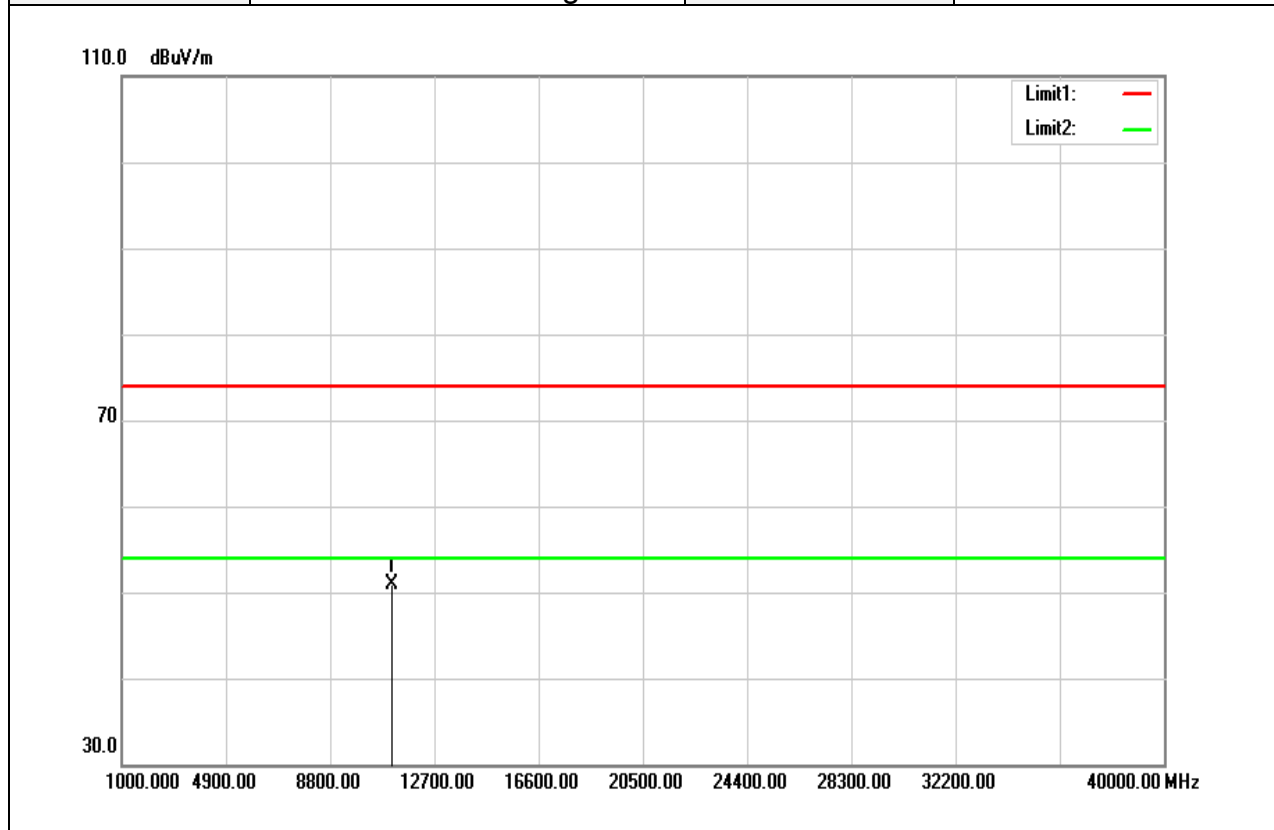

Frequency (MHz)	Reading (dBuV)	Correct Factor (dB/m)	Result (dBuV/m)	Limit (dBuV/m)	Margin (dB)	Remark
11100.000	34.74	16.07	50.81	74.00	-23.19	peak
N/A						

Remark:

1. Measuring frequencies from 1 GHz to the 10th harmonic of highest fundamental frequency.
2. For above 1GHz, the EUT peak value was under average limit, therefore the Average value compliance with the average limit

Test Mode	IEEE 802.11n HT40 Low CH	Temp/Hum	24(°C)/ 33%RH
Test Item	Harmonic	Test Date	December 2, 2017
Polarize	Horizontal	Test Engineer	Kevin Kuo
Detector	Peak and Average		

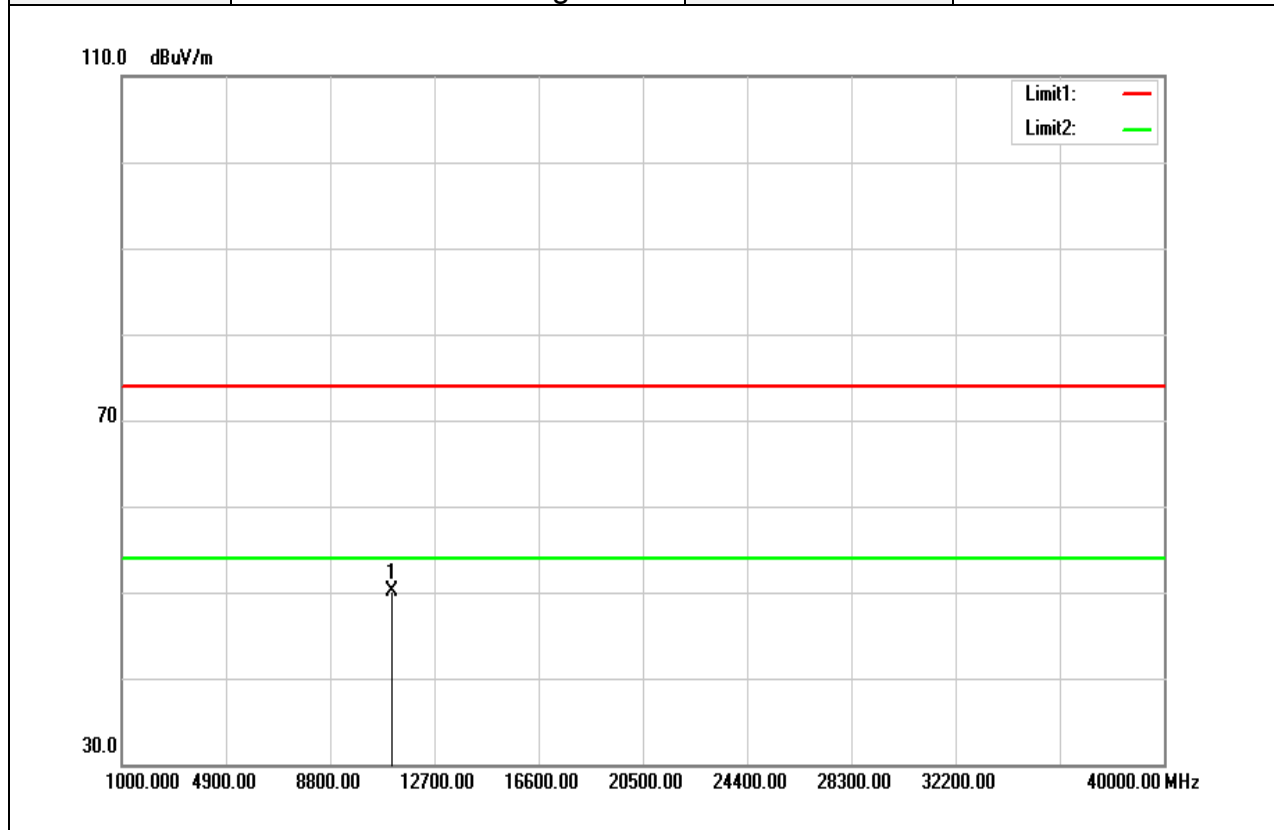

Frequency (MHz)	Reading (dBuV)	Correct Factor (dB/m)	Result (dBuV/m)	Limit (dBuV/m)	Margin (dB)	Remark
11100.000	34.05	16.07	50.12	74.00	-23.88	peak
N/A						

Remark:

1. Measuring frequencies from 1 GHz to the 10th harmonic of highest fundamental frequency.
2. For above 1GHz, the EUT peak value was under average limit, therefore the Average value compliance with the average limit

Test Mode	IEEE 802.11n HT40 Mid CH	Temp/Hum	24(°C)/ 33%RH
Test Item	Harmonic	Test Date	December 2, 2017
Polarize	Vertical	Test Engineer	Kevin Kuo
Detector	Peak and Average		

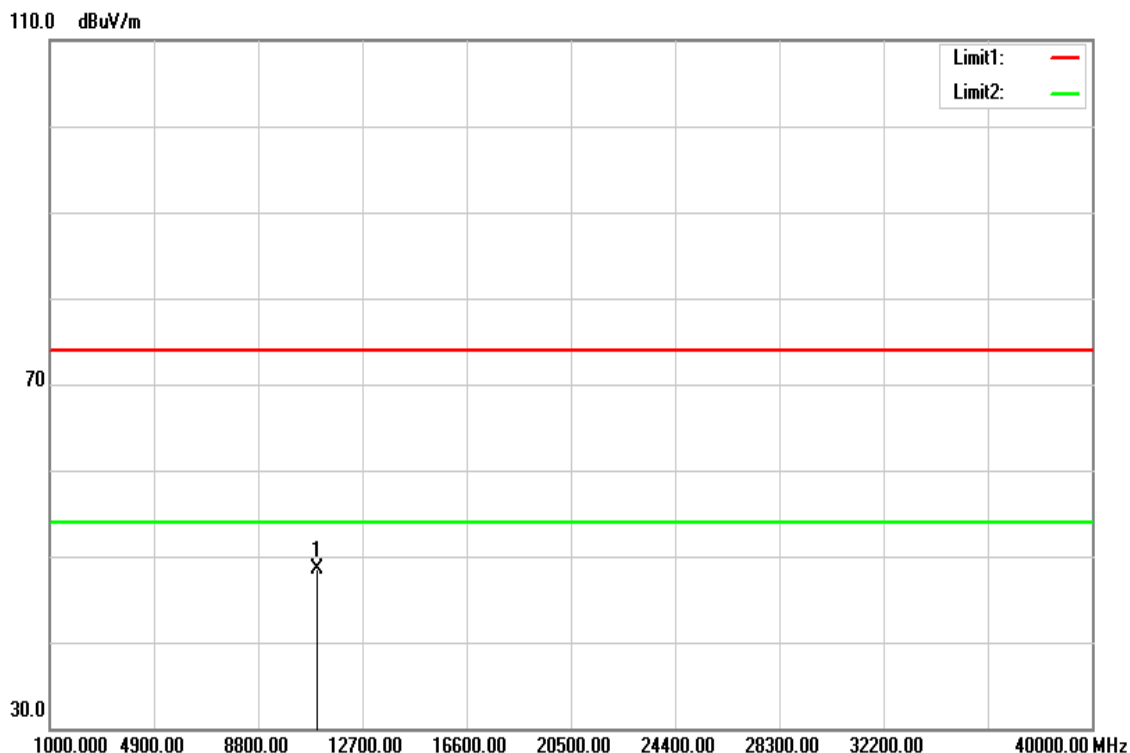

Frequency (MHz)	Reading (dBuV)	Correct Factor (dB/m)	Result (dBuV/m)	Limit (dBuV/m)	Margin (dB)	Remark
11020.000	32.36	16.05	48.41	74.00	-25.59	peak
N/A						

Remark:

1. Measuring frequencies from 1 GHz to the 10th harmonic of highest fundamental frequency.
2. For above 1GHz, the EUT peak value was under average limit, therefore the Average value compliance with the average limit

Test Mode	IEEE 802.11n HT40 Mid CH	Temp/Hum	24(°C)/ 33%RH
Test Item	Harmonic	Test Date	December 2, 2017
Polarize	Horizontal	Test Engineer	Kevin Kuo
Detector	Peak and Average		

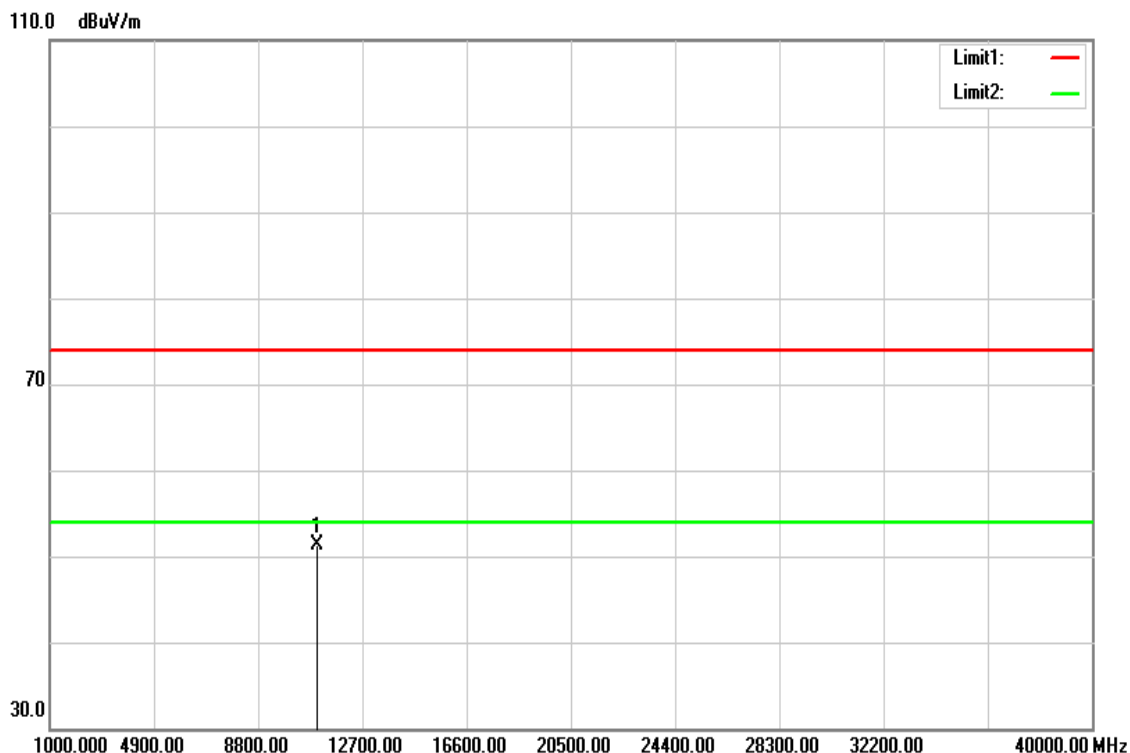

Frequency (MHz)	Reading (dBuV)	Correct Factor (dB/m)	Result (dBuV/m)	Limit (dBuV/m)	Margin (dB)	Remark
11020.000	35.16	16.05	51.21	74.00	-22.79	peak
N/A						

Remark:

1. Measuring frequencies from 1 GHz to the 10th harmonic of highest fundamental frequency.
2. For above 1GHz, the EUT peak value was under average limit, therefore the Average value compliance with the average limit

Test Mode	IEEE 802.11n HT40 High CH	Temp/Hum	24(°C)/ 33%RH
Test Item	Harmonic	Test Date	December 2, 2017
Polarize	Vertical	Test Engineer	Kevin Kuo
Detector	Peak and Average		

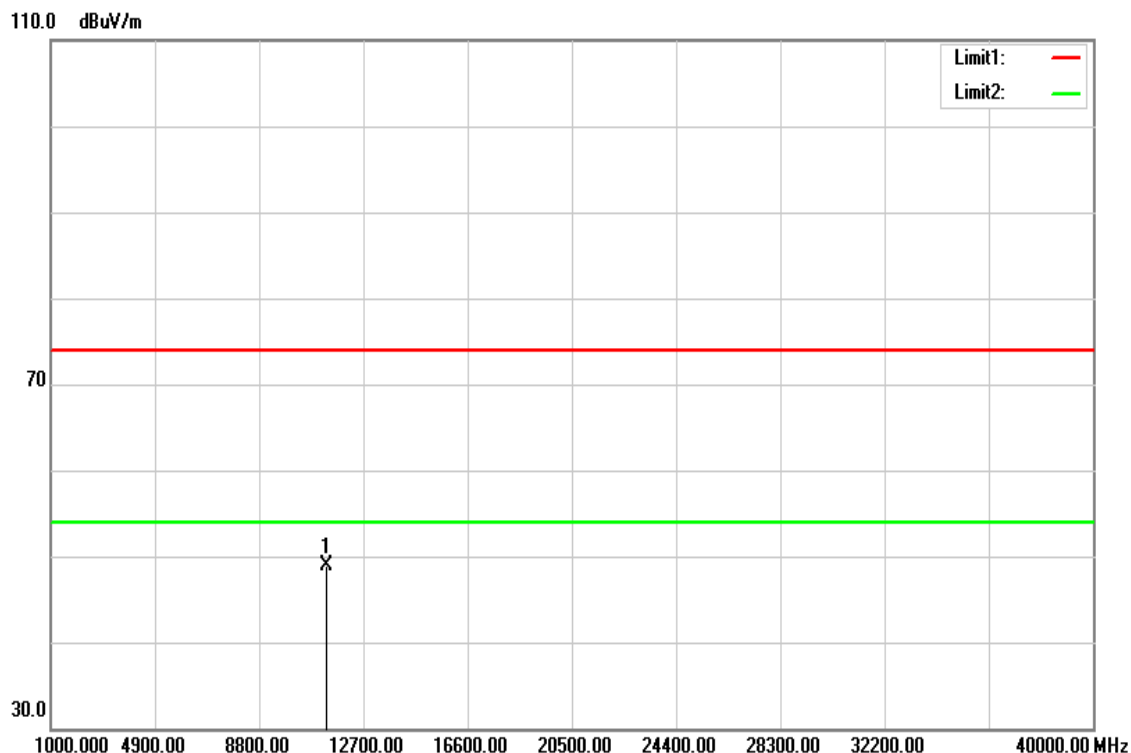

Frequency (MHz)	Reading (dBuV)	Correct Factor (dB/m)	Result (dBuV/m)	Limit (dBuV/m)	Margin (dB)	Remark
11340.000	32.90	16.08	48.98	74.00	-25.02	Peak
N/A						

Remark:

1. Measuring frequencies from 1 GHz to the 10th harmonic of highest fundamental frequency.
2. For above 1GHz, the EUT peak value was under average limit, therefore the Average value compliance with the average limit

Test Mode	IEEE 802.11n HT40 High CH	Temp/Hum	24(°C)/ 33%RH
Test Item	Harmonic	Test Date	December 2, 2017
Polarize	Horizontal	Test Engineer	Kevin Kuo
Detector	Peak and Average		

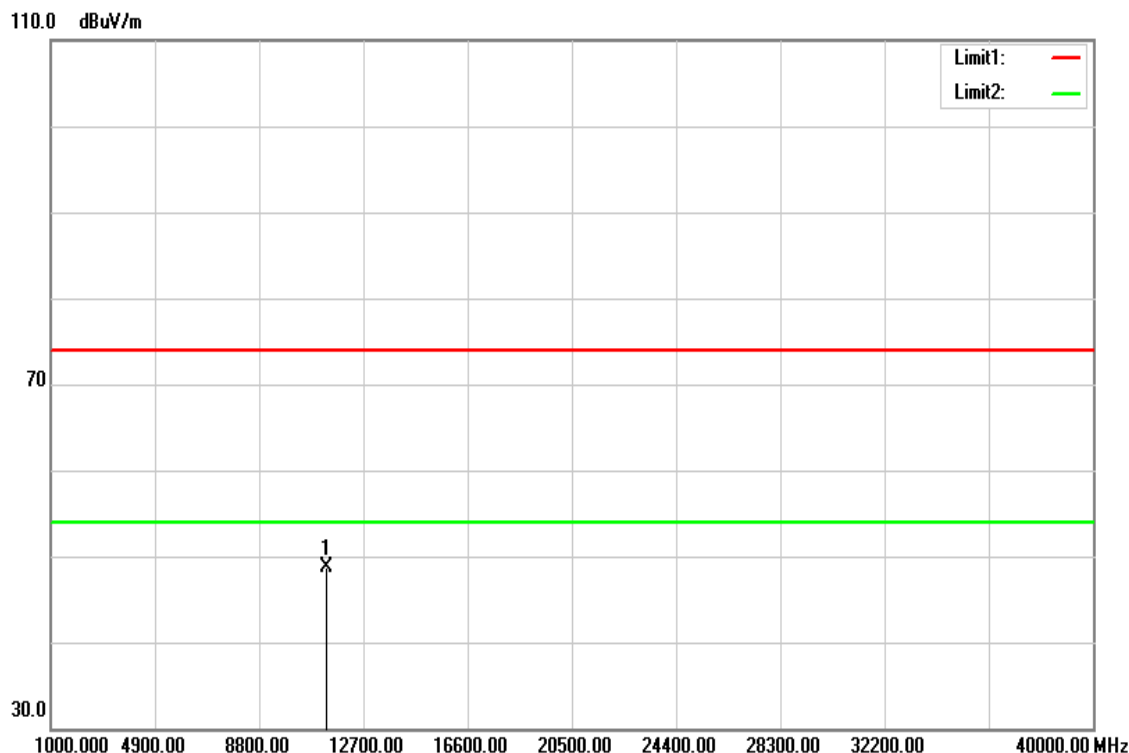

Frequency (MHz)	Reading (dBuV)	Correct Factor (dB/m)	Result (dBuV/m)	Limit (dBuV/m)	Margin (dB)	Remark
11340.000	32.67	16.08	48.75	74.00	-25.25	peak
N/A						

Remark:

1. Measuring frequencies from 1 GHz to the 10th harmonic of highest fundamental frequency.
2. For above 1GHz, the EUT peak value was under average limit, therefore the Average value compliance with the average limit

Above 1G Test Data for UNII-3

Test Mode	IEEE 802.11a Low CH	Temp/Hum	24(°C)/ 33%RH
Test Item	Harmonic	Test Date	December 2, 2017
Polarize	Vertical	Test Engineer	Kevin Kuo
Detector	Peak and Average		

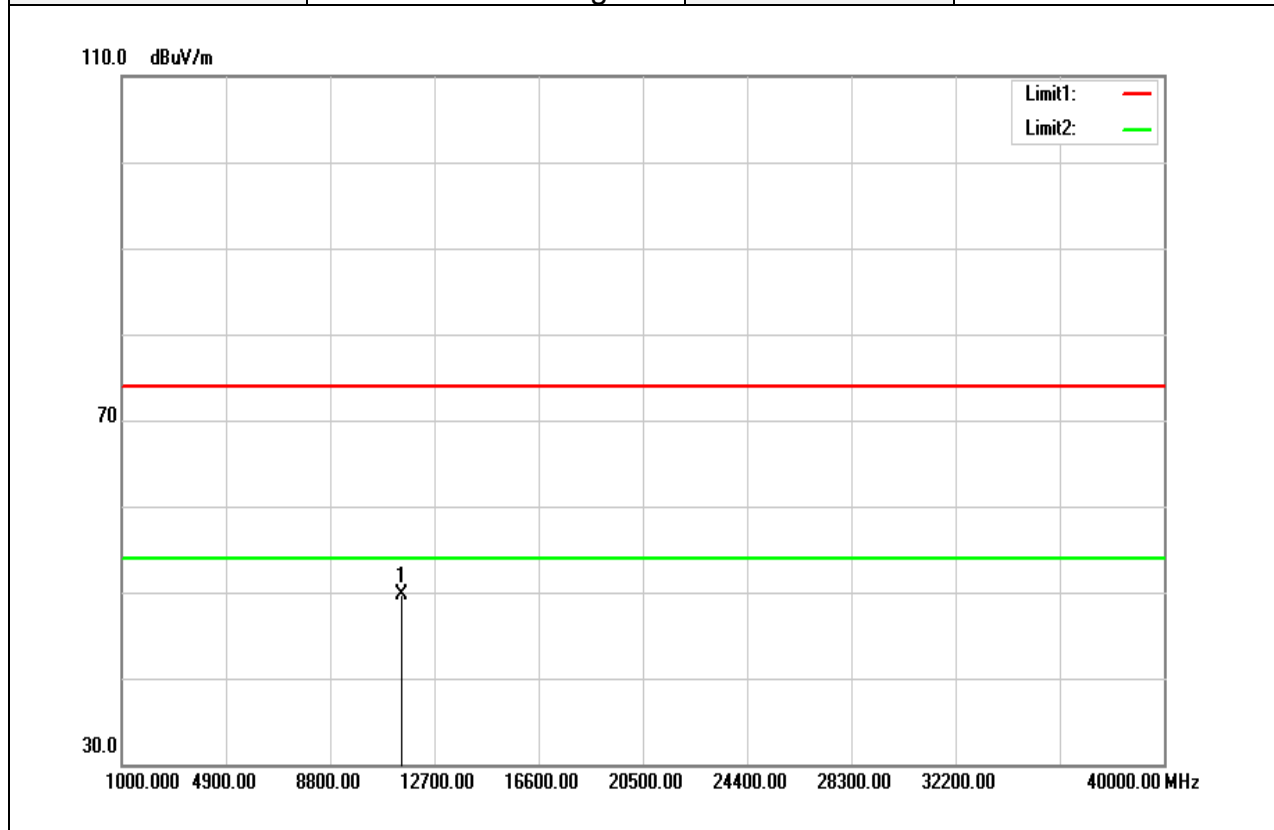

Frequency (MHz)	Reading (dBuV)	Correct Factor (dB/m)	Result (dBuV/m)	Limit (dBuV/m)	Margin (dB)	Remark
11490.000	33.65	16.09	49.74	74.00	-24.26	peak
N/A						

Remark:

1. Measuring frequencies from 1 GHz to the 10th harmonic of highest fundamental frequency.
2. For above 1GHz, the EUT peak value was under average limit, therefore the Average value compliance with the average limit

Test Mode	IEEE 802.11a Low CH	Temp/Hum	24(°C)/ 33%RH
Test Item	Harmonic	Test Date	December 2, 2017
Polarize	Horizontal	Test Engineer	Kevin Kuo
Detector	Peak and Average		

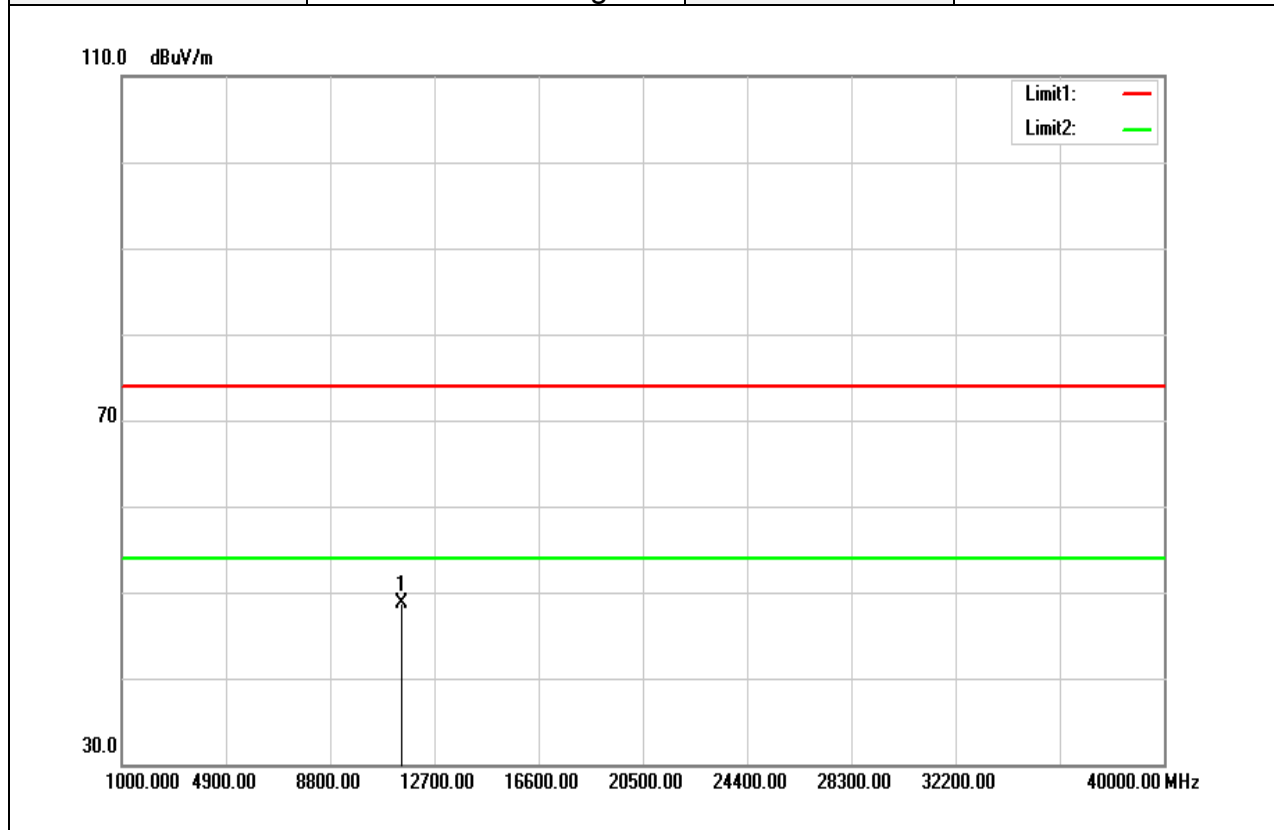

Frequency (MHz)	Reading (dBuV)	Correct Factor (dB/m)	Result (dBuV/m)	Limit (dBuV/m)	Margin (dB)	Remark
11490.000	32.65	16.09	48.74	74.00	-25.26	peak
N/A						

Remark:

1. Measuring frequencies from 1 GHz to the 10th harmonic of highest fundamental frequency.
2. For above 1GHz, the EUT peak value was under average limit, therefore the Average value compliance with the average limit

Test Mode	IEEE 802.11a Mid CH	Temp/Hum	24(°C)/ 33%RH
Test Item	Harmonic	Test Date	December 2, 2017
Polarize	Vertical	Test Engineer	Kevin Kuo
Detector	Peak and Average		

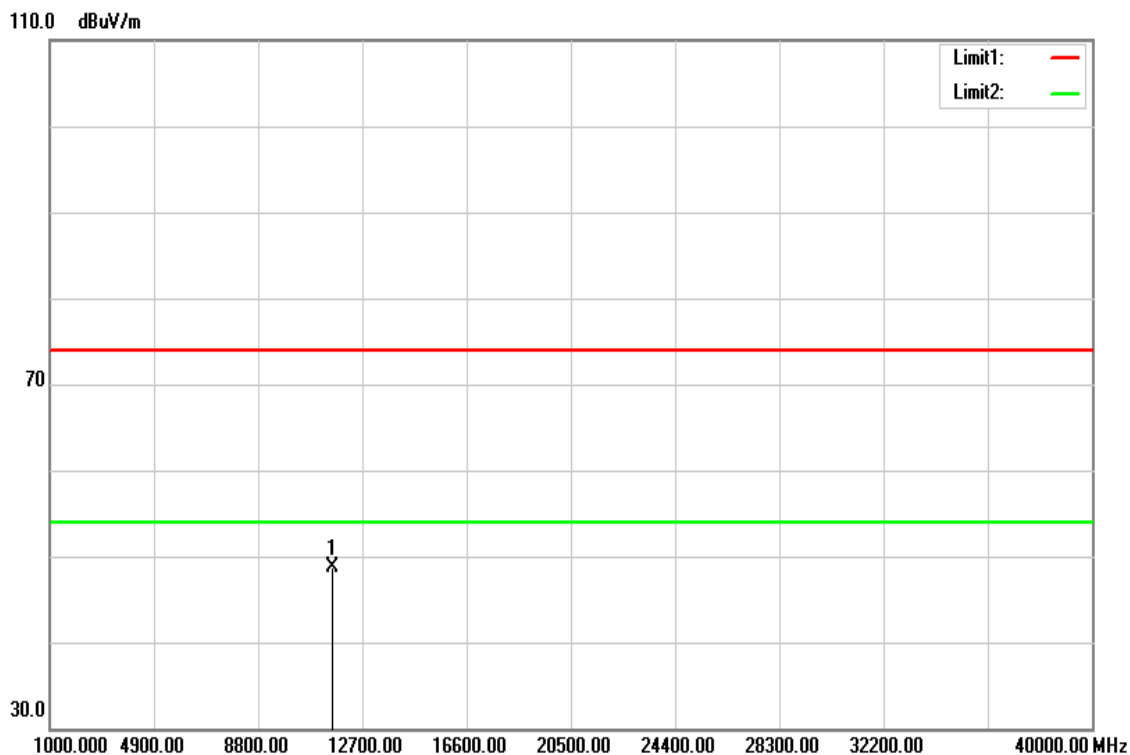

Frequency (MHz)	Reading (dBuV)	Correct Factor (dB/m)	Result (dBuV/m)	Limit (dBuV/m)	Margin (dB)	Remark
11570.000	32.78	16.01	48.79	74.00	-25.21	peak
N/A						

Remark:

1. Measuring frequencies from 1 GHz to the 10th harmonic of highest fundamental frequency.
2. For above 1GHz, the EUT peak value was under average limit, therefore the Average value compliance with the average limit

Test Mode	IEEE 802.11a Mid CH	Temp/Hum	24(°C)/ 33%RH
Test Item	Harmonic	Test Date	December 2, 2017
Polarize	Horizontal	Test Engineer	Kevin Kuo
Detector	Peak and Average		

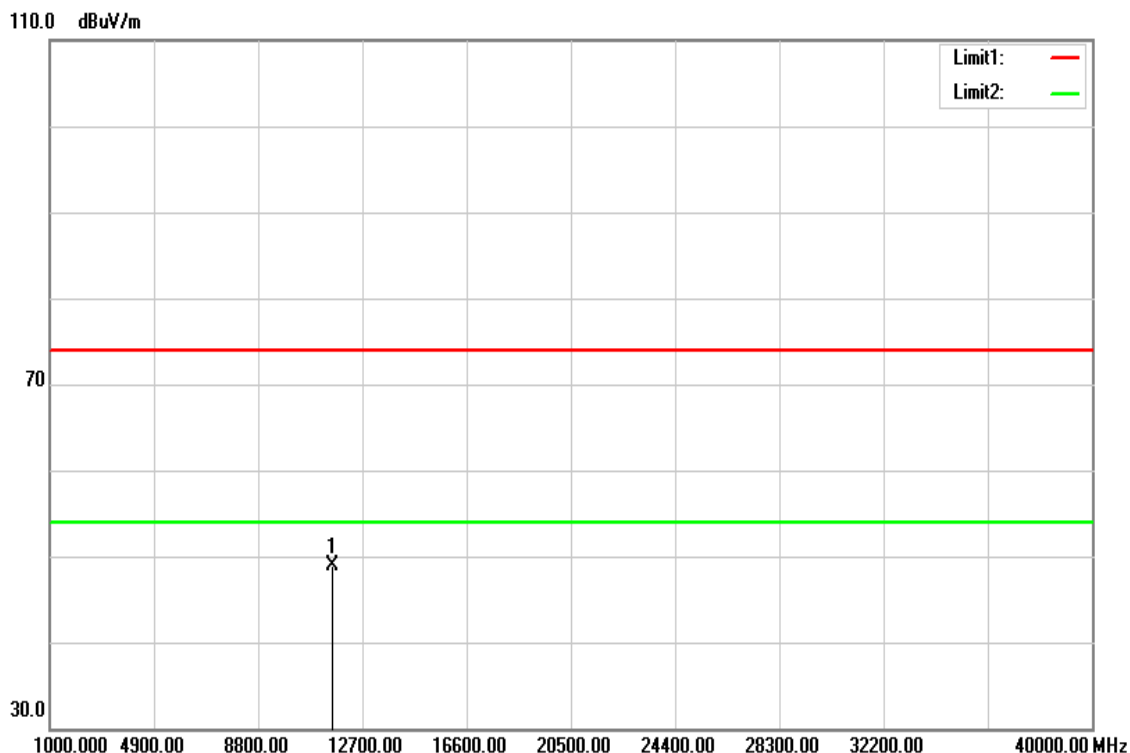

Frequency (MHz)	Reading (dBuV)	Correct Factor (dB/m)	Result (dBuV/m)	Limit (dBuV/m)	Margin (dB)	Remark
11570.000	32.84	16.01	48.85	74.00	-25.15	peak
N/A						

Remark:

1. Measuring frequencies from 1 GHz to the 10th harmonic of highest fundamental frequency.
2. For above 1GHz, the EUT peak value was under average limit, therefore the Average value compliance with the average limit

Test Mode	IEEE 802.11a High CH	Temp/Hum	24(°C)/ 33%RH
Test Item	Harmonic	Test Date	December 2, 2017
Polarize	Vertical	Test Engineer	Kevin Kuo
Detector	Peak and Average		

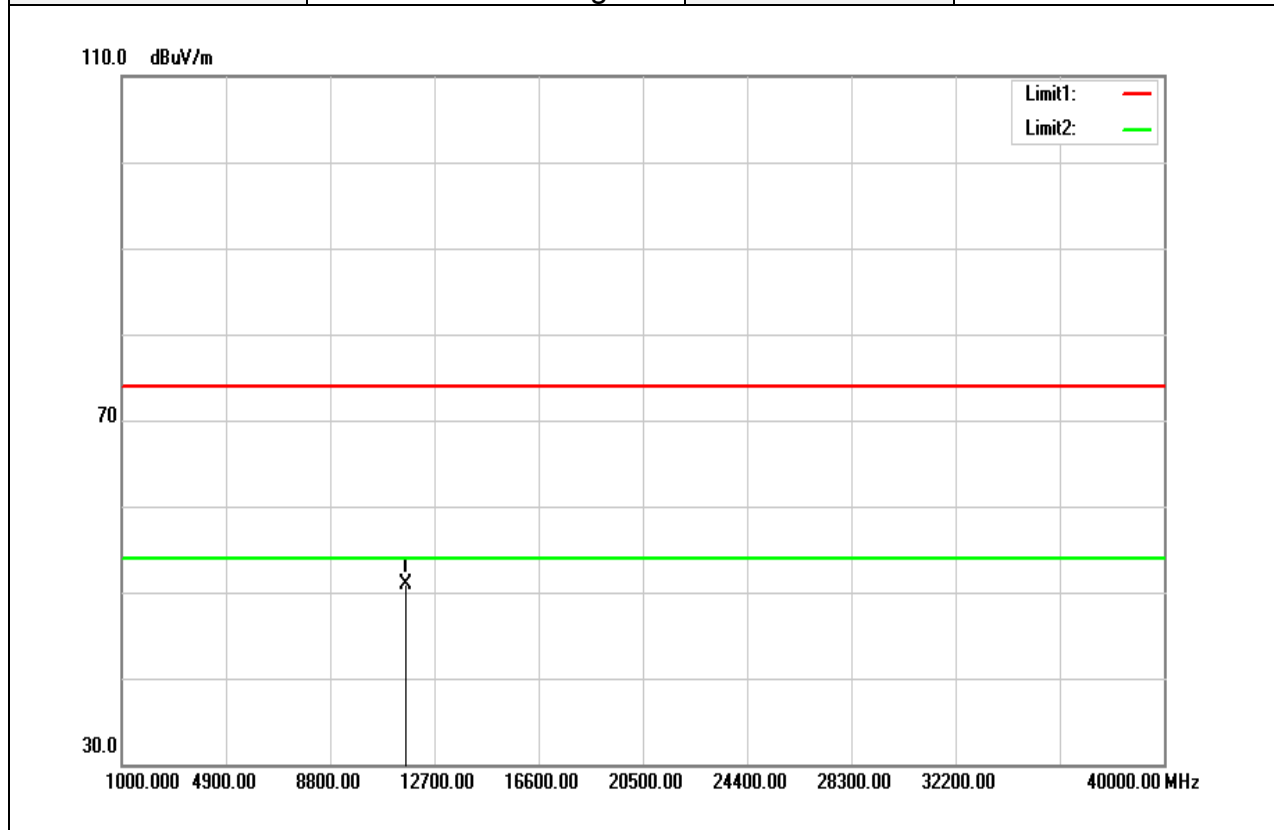

Frequency (MHz)	Reading (dBuV)	Correct Factor (dB/m)	Result (dBuV/m)	Limit (dBuV/m)	Margin (dB)	Remark
11650.000	29.99	19.57	49.56	74.00	-24.44	peak
N/A						

Remark:

1. Measuring frequencies from 1 GHz to the 10th harmonic of highest fundamental frequency.
2. For above 1GHz, the EUT peak value was under average limit, therefore the Average value compliance with the average limit

Test Mode	IEEE 802.11a High CH	Temp/Hum	24(°C)/ 33%RH
Test Item	Harmonic	Test Date	December 2, 2017
Polarize	Horizontal	Test Engineer	Kevin Kuo
Detector	Peak and Average		

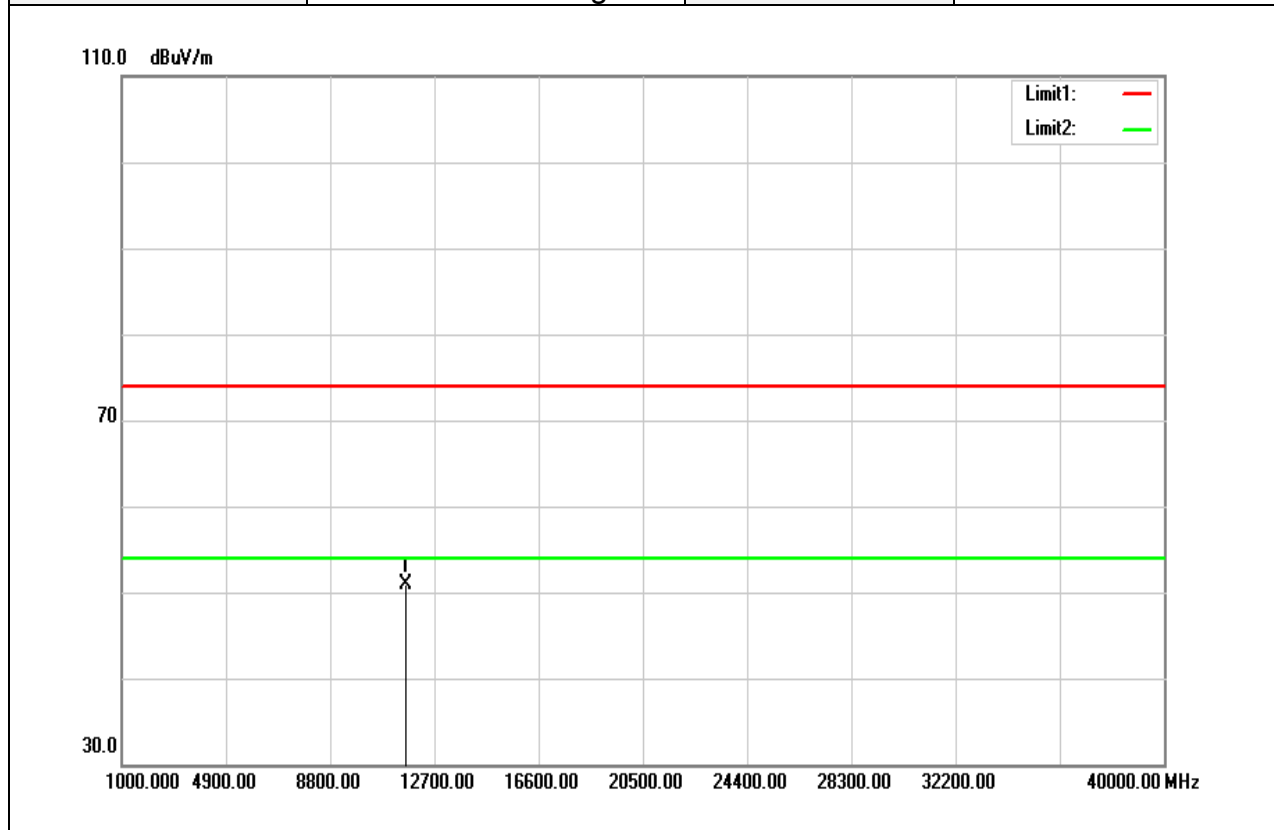

Frequency (MHz)	Reading (dBuV)	Correct Factor (dB/m)	Result (dBuV/m)	Limit (dBuV/m)	Margin (dB)	Remark
11650.000	34.51	15.93	50.44	74.00	-23.56	peak
N/A						

Remark:

1. Measuring frequencies from 1 GHz to the 10th harmonic of highest fundamental frequency.
2. For above 1GHz, the EUT peak value was under average limit, therefore the Average value compliance with the average limit

Test Mode	IEEE 802.11n HT20 Low CH	Temp/Hum	24(°C)/ 33%RH
Test Item	Harmonic	Test Date	December 2, 2017
Polarize	Vertical	Test Engineer	Kevin Kuo
Detector	Peak and Average		

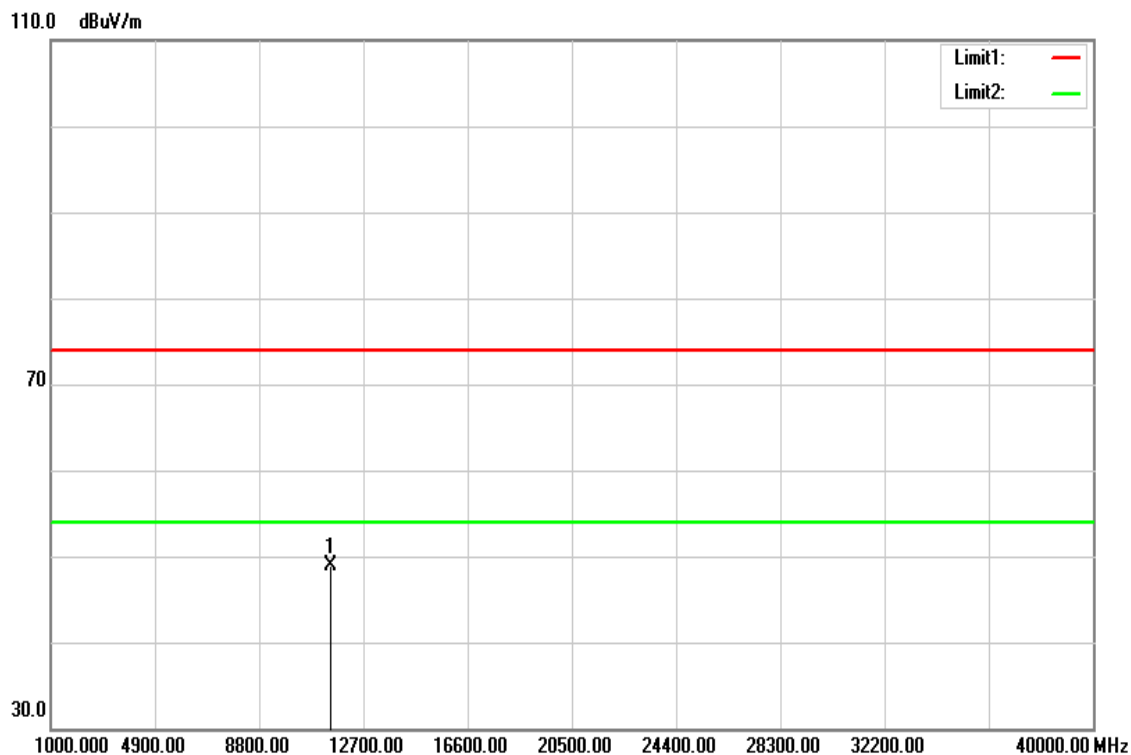

Frequency (MHz)	Reading (dBuV)	Correct Factor (dB/m)	Result (dBuV/m)	Limit (dBuV/m)	Margin (dB)	Remark
11490.000	32.77	16.09	48.86	74.00	-25.14	peak
N/A						

Remark:

1. Measuring frequencies from 1 GHz to the 10th harmonic of highest fundamental frequency.
2. For above 1GHz, the EUT peak value was under average limit, therefore the Average value compliance with the average limit

Test Mode	IEEE 802.11n HT20 Low CH	Temp/Hum	24(°C)/ 33%RH
Test Item	Harmonic	Test Date	December 2, 2017
Polarize	Horizontal	Test Engineer	Kevin Kuo
Detector	Peak and Average		

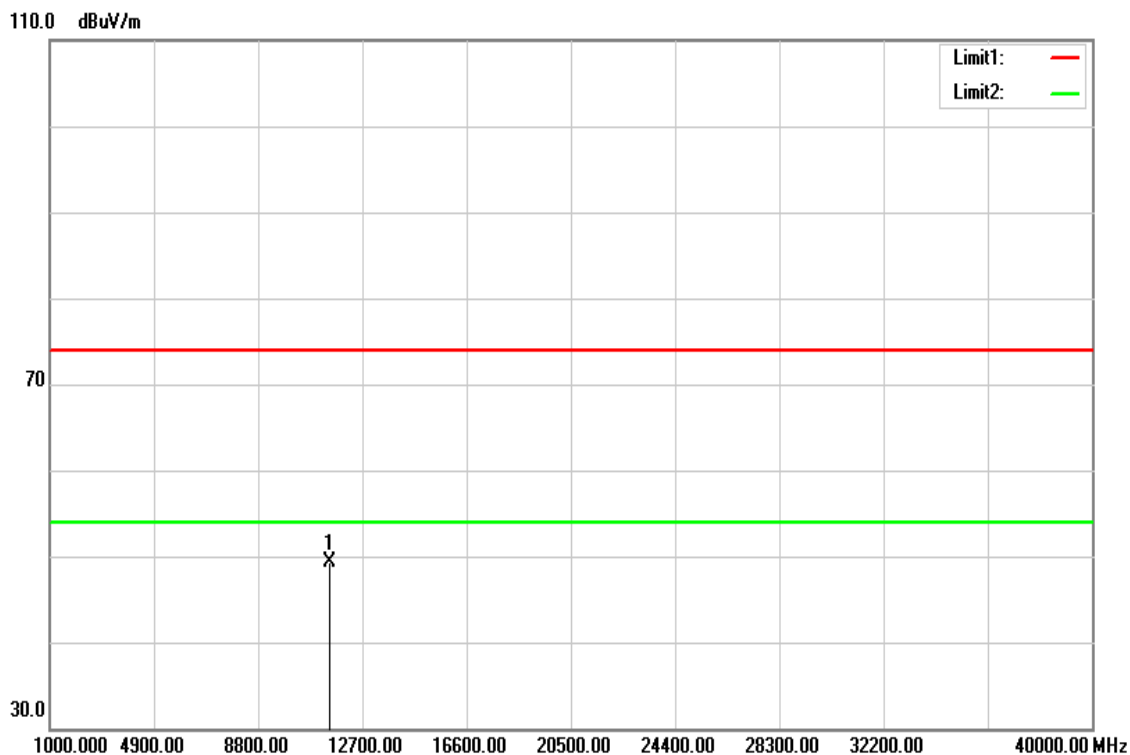

Frequency (MHz)	Reading (dBuV)	Correct Factor (dB/m)	Result (dBuV/m)	Limit (dBuV/m)	Margin (dB)	Remark
11490.000	33.14	16.09	49.23	74.00	-24.77	peak
N/A						

Remark:

1. Measuring frequencies from 1 GHz to the 10th harmonic of highest fundamental frequency.
2. For above 1GHz, the EUT peak value was under average limit, therefore the Average value compliance with the average limit

Test Mode	IEEE 802.11n HT20 Mid CH	Temp/Hum	24(°C)/ 33%RH
Test Item	Harmonic	Test Date	December 2, 2017
Polarize	Vertical	Test Engineer	Kevin Kuo
Detector	Peak and Average		

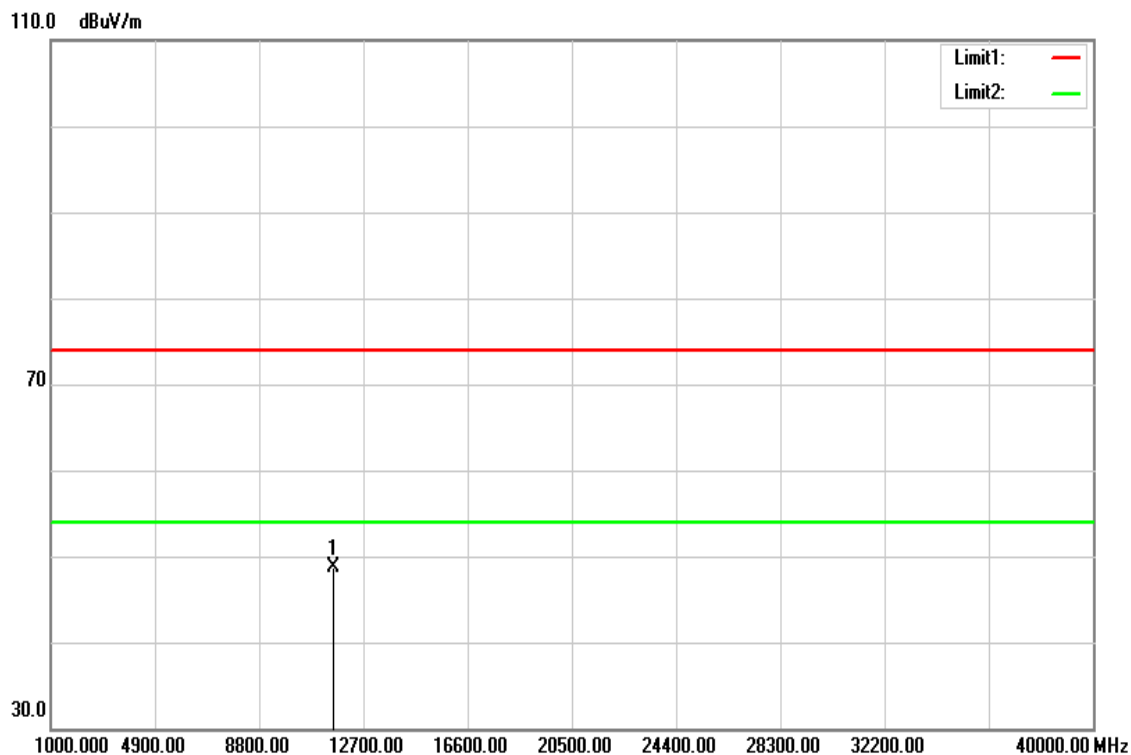

Frequency (MHz)	Reading (dBuV)	Correct Factor (dB/m)	Result (dBuV/m)	Limit (dBuV/m)	Margin (dB)	Remark
11570.000	32.68	16.01	48.69	74.00	-25.31	peak
N/A						

Remark:

1. Measuring frequencies from 1 GHz to the 10th harmonic of highest fundamental frequency.
2. For above 1GHz, the EUT peak value was under average limit, therefore the Average value compliance with the average limit

Test Mode	IEEE 802.11n HT20 Mid CH	Temp/Hum	24(°C)/ 33%RH
Test Item	Harmonic	Test Date	December 2, 2017
Polarize	Horizontal	Test Engineer	Kevin Kuo
Detector	Peak and Average		

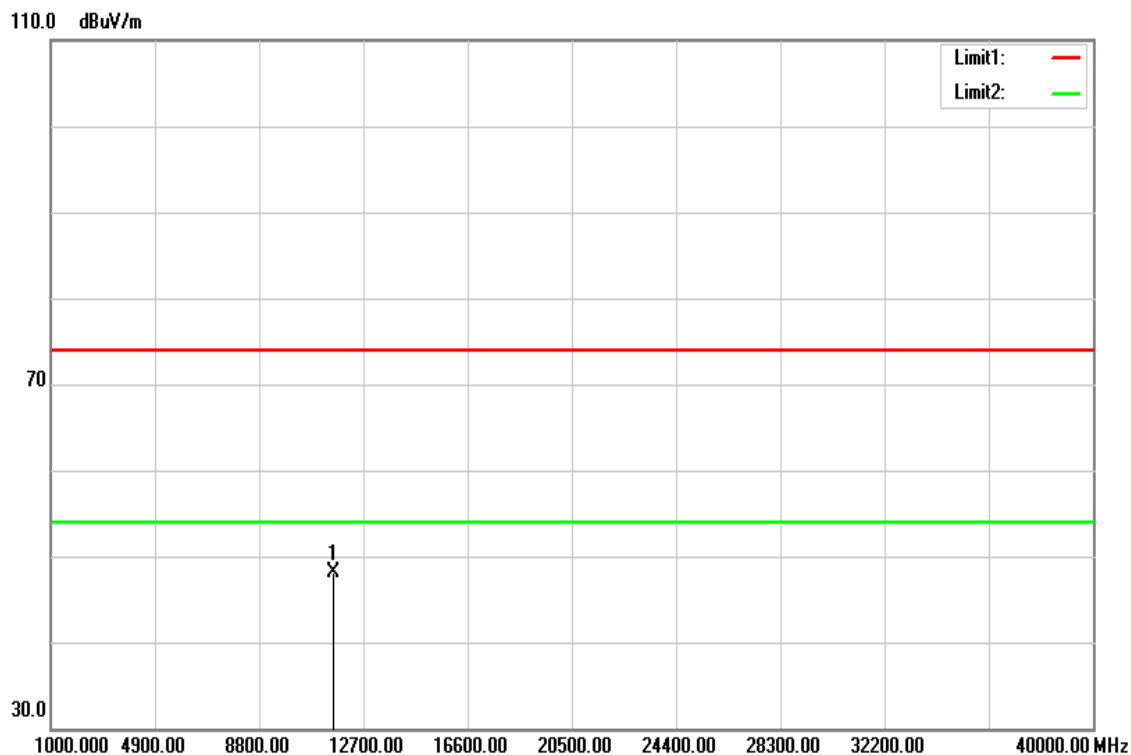

Frequency (MHz)	Reading (dBuV)	Correct Factor (dB/m)	Result (dBuV/m)	Limit (dBuV/m)	Margin (dB)	Remark
11570.000	32.11	16.01	48.12	74.00	-25.88	peak
N/A						

Remark:

1. Measuring frequencies from 1 GHz to the 10th harmonic of highest fundamental frequency.
2. For above 1GHz, the EUT peak value was under average limit, therefore the Average value compliance with the average limit

Test Mode	IEEE 802.11n HT20 High CH	Temp/Hum	24(°C)/ 33%RH
Test Item	Harmonic	Test Date	December 2, 2017
Polarize	Vertical	Test Engineer	Kevin Kuo
Detector	Peak and Average		

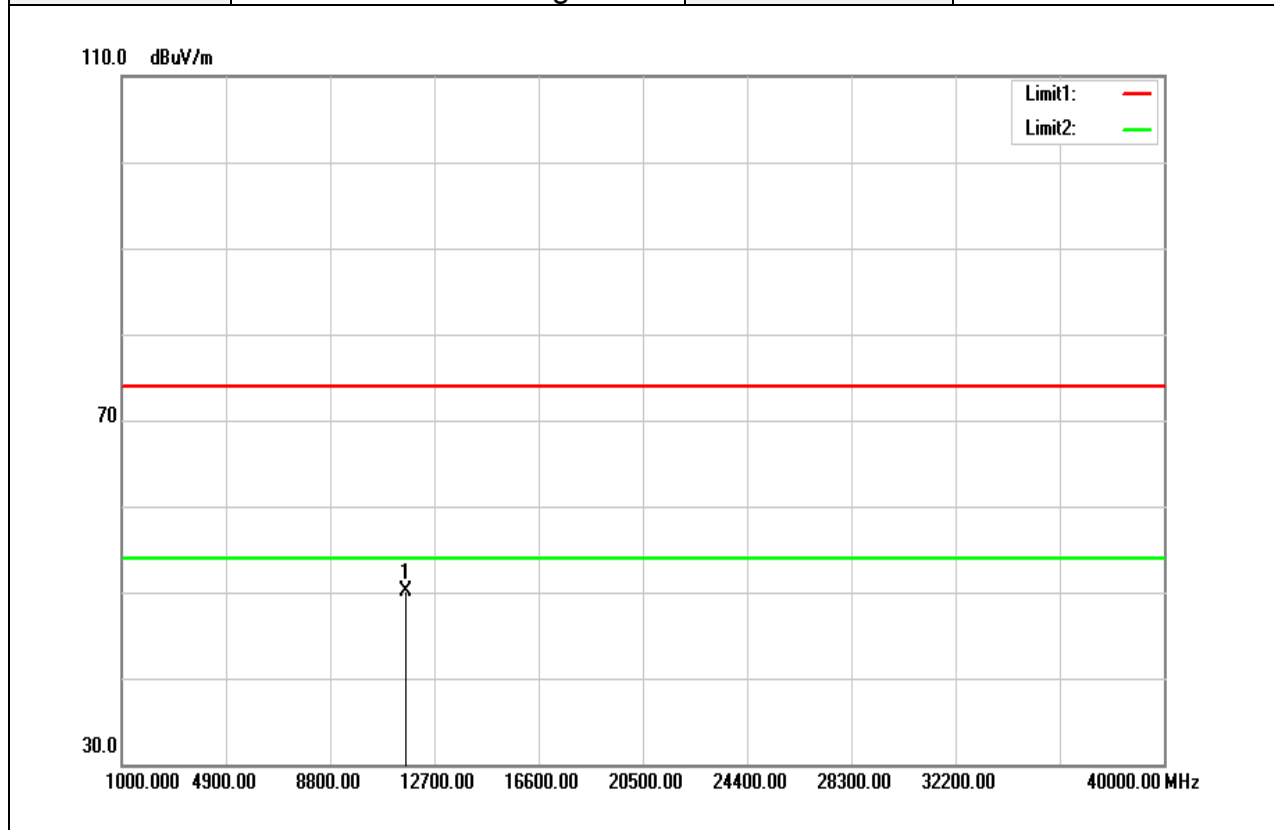

Frequency (MHz)	Reading (dBuV)	Correct Factor (dB/m)	Result (dBuV/m)	Limit (dBuV/m)	Margin (dB)	Remark
11650.000	34.24	15.93	50.17	74.00	-23.83	peak
N/A						

Remark:

1. Measuring frequencies from 1 GHz to the 10th harmonic of highest fundamental frequency.
2. For above 1GHz, the EUT peak value was under average limit, therefore the Average value compliance with the average limit

Test Mode	IEEE 802.11n HT20 High CH	Temp/Hum	24(°C)/ 33%RH
Test Item	Harmonic	Test Date	December 2, 2017
Polarize	Horizontal	Test Engineer	Kevin Kuo
Detector	Peak and Average		

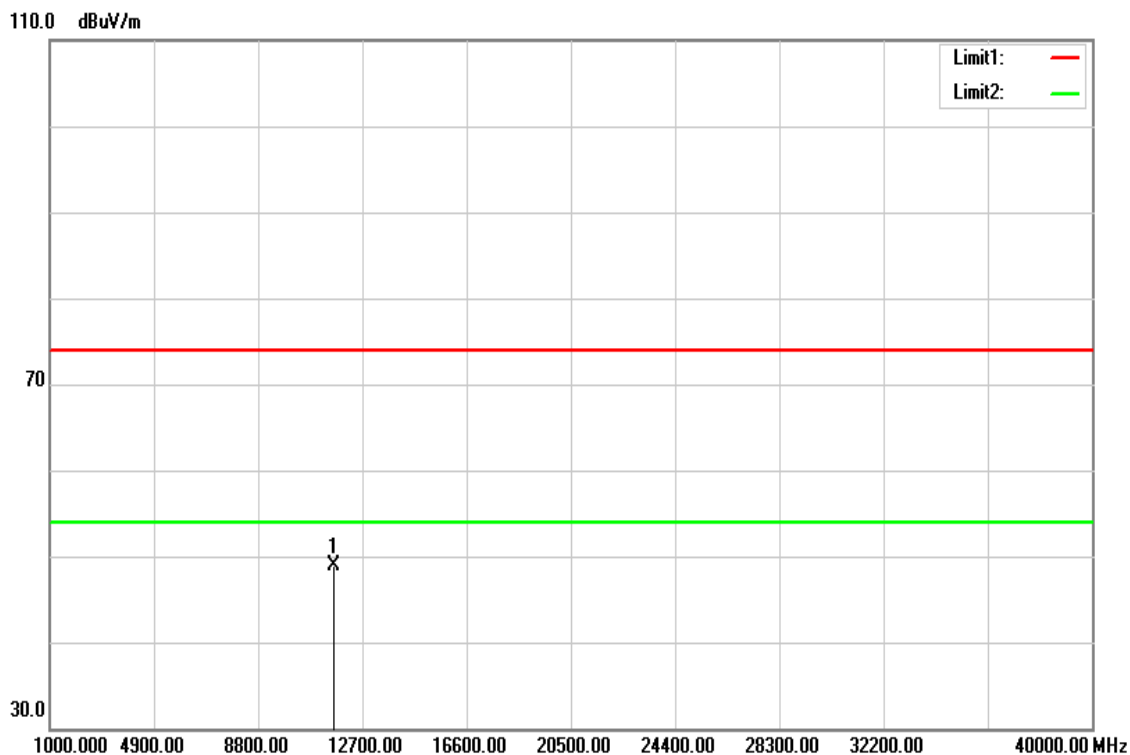

Frequency (MHz)	Reading (dBuV)	Correct Factor (dB/m)	Result (dBuV/m)	Limit (dBuV/m)	Margin (dB)	Remark
11650.000	33.01	15.93	48.94	74.00	-25.06	peak
N/A						

Remark:

1. Measuring frequencies from 1 GHz to the 10th harmonic of highest fundamental frequency.
2. For above 1GHz, the EUT peak value was under average limit, therefore the Average value compliance with the average limit

Test Mode	IEEE 802.11n HT40 Low CH	Temp/Hum	24(°C)/ 33%RH
Test Item	Harmonic	Test Date	December 2, 2017
Polarize	Vertical	Test Engineer	Kevin Kuo
Detector	Peak and Average		

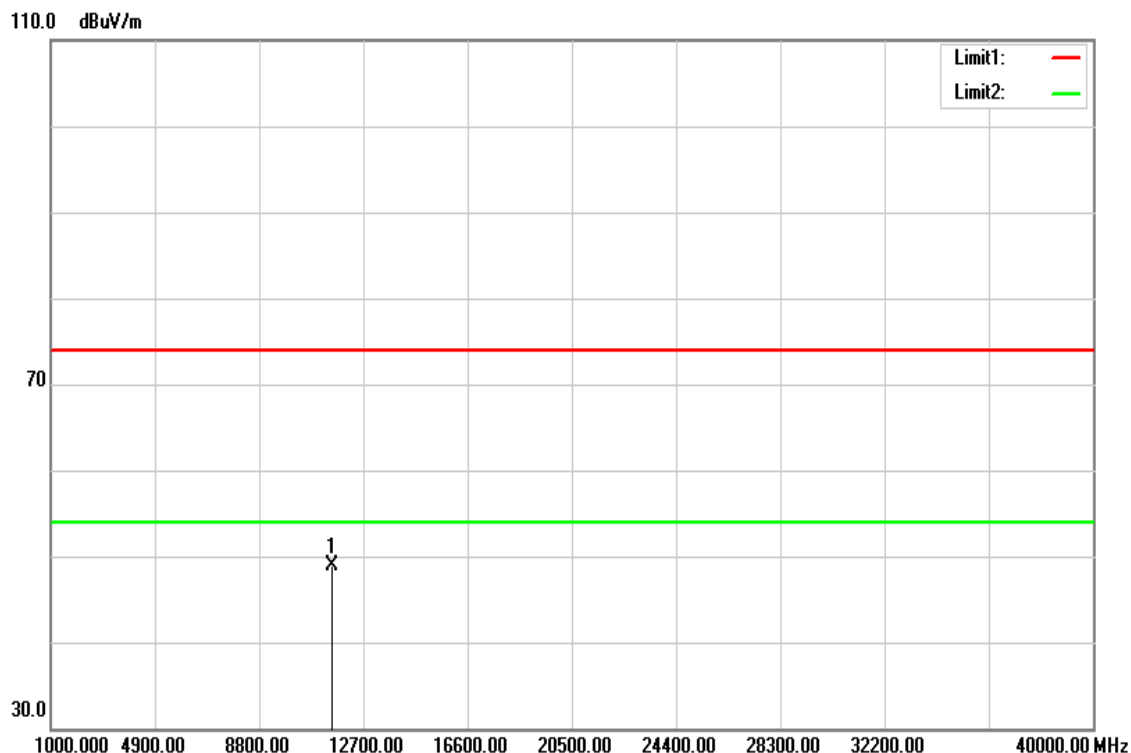

Frequency (MHz)	Reading (dBuV)	Correct Factor (dB/m)	Result (dBuV/m)	Limit (dBuV/m)	Margin (dB)	Remark
11510.000	32.83	16.08	48.91	74.00	-25.09	peak
N/A						

Remark:

1. Measuring frequencies from 1 GHz to the 10th harmonic of highest fundamental frequency.
2. For above 1GHz, the EUT peak value was under average limit, therefore the Average value compliance with the average limit

Test Mode	IEEE 802.11n HT40 Low CH	Temp/Hum	24(°C)/ 33%RH
Test Item	Harmonic	Test Date	December 2, 2017
Polarize	Horizontal	Test Engineer	Kevin Kuo
Detector	Peak and Average		

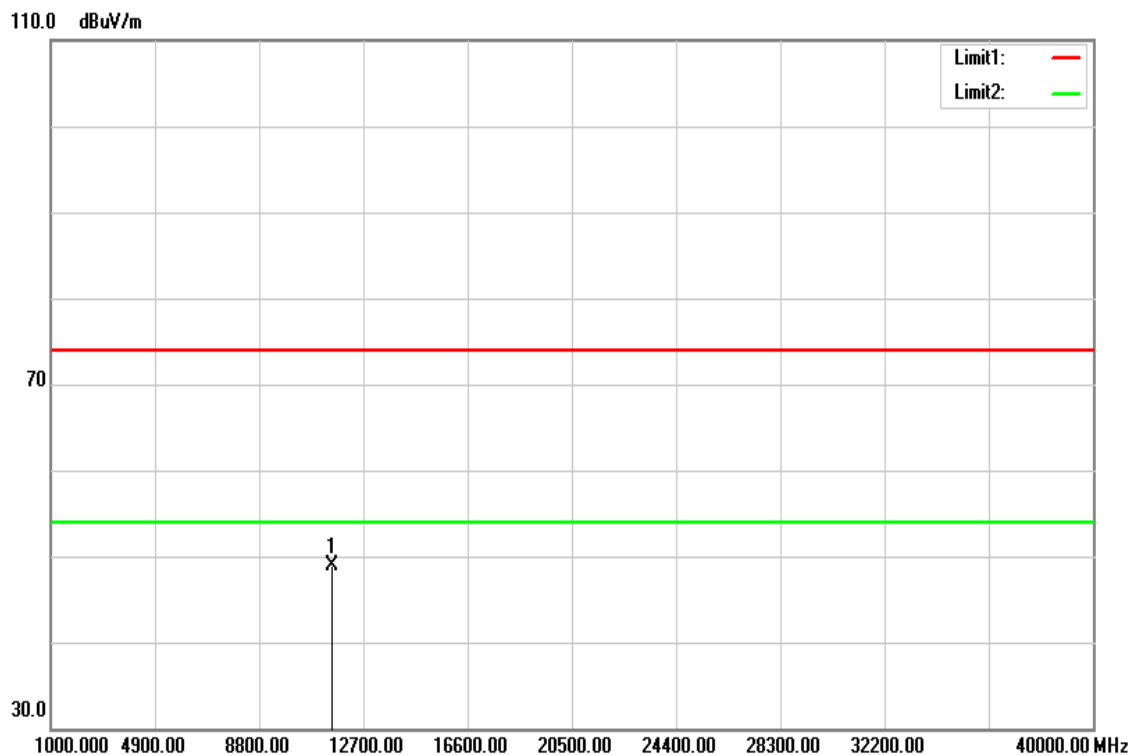

Frequency (MHz)	Reading (dBuV)	Correct Factor (dB/m)	Result (dBuV/m)	Limit (dBuV/m)	Margin (dB)	Remark
11510.000	32.81	16.08	48.89	74.00	-25.11	peak
N/A						

Remark:

1. Measuring frequencies from 1 GHz to the 10th harmonic of highest fundamental frequency.
2. For above 1GHz, the EUT peak value was under average limit, therefore the Average value compliance with the average limit

Test Mode	IEEE 802.11n HT40 High CH	Temp/Hum	24(°C)/ 33%RH
Test Item	Harmonic	Test Date	December 2, 2017
Polarize	Vertical	Test Engineer	Kevin Kuo
Detector	Peak and Average		

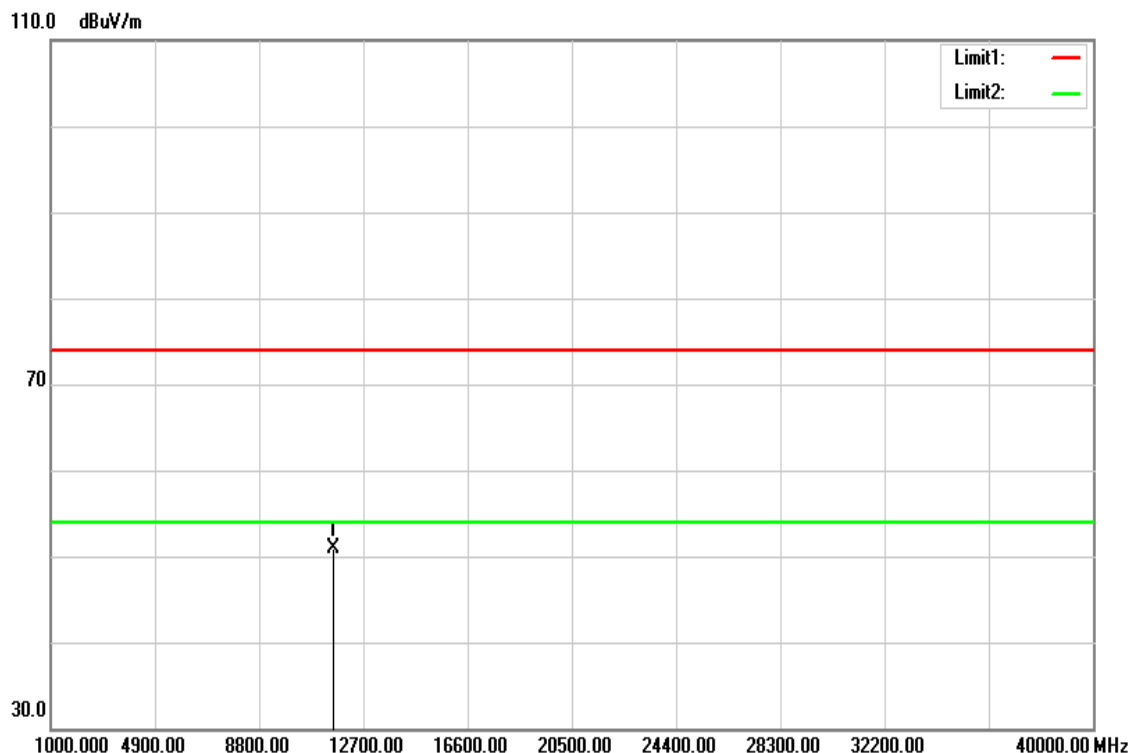

Frequency (MHz)	Reading (dBuV)	Correct Factor (dB/m)	Result (dBuV/m)	Limit (dBuV/m)	Margin (dB)	Remark
11590.000	34.87	16.00	50.87	74.00	-23.13	peak
N/A						

Remark:

1. Measuring frequencies from 1 GHz to the 10th harmonic of highest fundamental frequency.
2. For above 1GHz, the EUT peak value was under average limit, therefore the Average value compliance with the average limit

Test Mode	IEEE 802.11n HT40 High CH	Temp/Hum	24(°C)/ 33%RH
Test Item	Harmonic	Test Date	December 2, 2017
Polarize	Horizontal	Test Engineer	Kevin Kuo
Detector	Peak and Average		

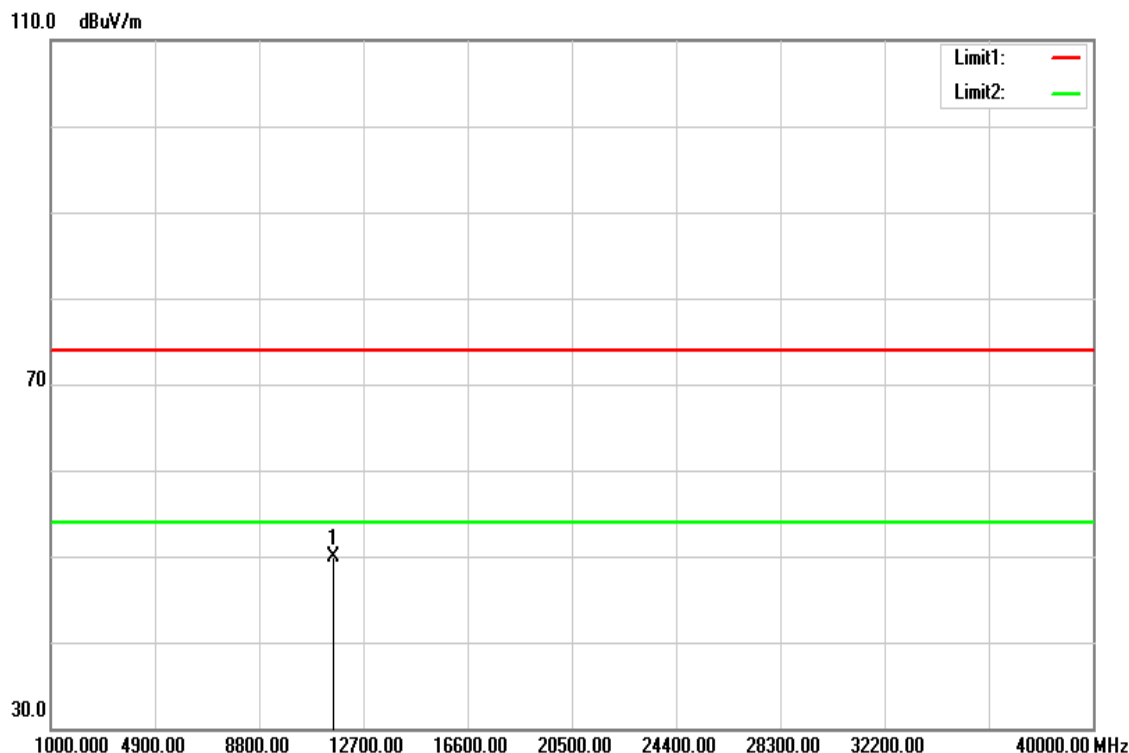

Frequency (MHz)	Reading (dBuV)	Correct Factor (dB/m)	Result (dBuV/m)	Limit (dBuV/m)	Margin (dB)	Remark
11590.000	33.84	16.00	49.84	74.00	-24.16	peak
N/A						

Remark:

1. Measuring frequencies from 1 GHz to the 10th harmonic of highest fundamental frequency.
2. For above 1GHz, the EUT peak value was under average limit, therefore the Average value compliance with the average limit