



SPORTON International Inc.

No. 52, Hwa Ya 1st Rd., Kwei-Shan Hsiang, TaoYuan Hsien, Taiwan, R.O.C.
Ph: 886-3-327-3456 / FAX: 886-3-327-0973 / www.sporton.com.tw

FCC RADIO TEST REPORT

Applicant's company	Realtek Semiconductor Corp.
Applicant Address	No. 2, Innovation Road II, Hsinchu Science Park, Hsinchu 300, Taiwan
FCC ID	TX2-RTL8812AE
Manufacturer's company	Realtek Semiconductor Corp.
Manufacturer Address	No. 2, Innovation Road II, Hsinchu Science Park, Hsinchu 300, Taiwan

Product Name	802.11a/b/g/n/ac RTL8812AE miniCard
Brand Name	Realtek
Model Name	RTL8812AE
Test Rule Part(s)	47 CFR FCC Part 15 Subpart E § 15.407
Test Freq. Range	5150 ~ 5250MHz
Received Date	Nov. 26, 2012
Final Test Date	Dec. 12, 2012
Submission Type	Original Equipment

Statement

Test result included is for the IEEE 802.11n and IEEE 802.11a/ac (5150 ~ 5250MHz) of the product.

The test result in this report refers exclusively to the presented test model / sample.

Without written approval of SPORTON International Inc., the test report shall not be reproduced except in full.

The measurements and test results shown in this test report were made in accordance with the procedures and found in compliance with the limit given in **ANSI C63.10-2009**,

47 CFR FCC Part 15 Subpart E and **KDB 789033 D01 v01r02, KDB662911D01 v01r02.**

The test equipment used to perform the test is calibrated and traceable to NML/ROC.



Table of Contents

1. CERTIFICATE OF COMPLIANCE	1
2. SUMMARY OF THE TEST RESULT	2
3. GENERAL INFORMATION	3
3.1. Product Details	3
3.2. Accessories	6
3.3. Table for Filed Antenna	6
3.4. Table for Carrier Frequencies	8
3.5. Table for Test Modes	9
3.6. Table for Testing Locations.....	10
3.7. Table for Supporting Units	10
3.8. Table for Parameters of Test Software Setting	11
3.9. Test Configurations.....	13
4. TEST RESULT	16
4.1. AC Power Line Conducted Emissions Measurement	16
4.2. 99% Occupied Bandwidth Measurement.....	20
4.3. Maximum Conducted Output Power Measurement.....	37
4.4. Power Spectral Density Measurement.....	42
4.5. Peak Excursion Measurement	53
4.6. Radiated Emissions Measurement.....	60
4.7. Band Edge Emissions Measurement.....	81
4.8. Frequency Stability Measurement.....	94
4.9. Antenna Requirements	96
5. LIST OF MEASURING EQUIPMENTS	97
6. TEST LOCATION	99
7. TAF CERTIFICATE OF ACCREDITATION	100
APPENDIX A. TEST PHOTOS	A1 ~ A6
APPENDIX B. MAXIMUM PERMISSIBLE EXPOSURE	B1 ~ B3



History of This Test Report

REPORT NO.	VERSION	DESCRIPTION	ISSUED DATE
FR2N2613AB	Rev. 01	Initial issue of report	Jan. 02, 2013

1. CERTIFICATE OF COMPLIANCE

Product Name : 802.11a/b/g/n/ac RTL8812AE miniCard
Brand Name : Realtek
Model Name : RTL8812AE
Applicant : Realtek Semiconductor Corp.
Test Rule Part(s) : 47 CFR FCC Part 15 Subpart E § 15.407

Sporton International as requested by the applicant to evaluate the EMC performance of the product sample received on Nov. 26, 2012 would like to declare that the tested sample has been evaluated and found to be in compliance with the tested rule parts. The data recorded as well as the test configuration specified is true and accurate for showing the sample's EMC nature.

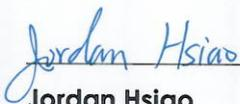

Jordan Hsiao

SPORTON INTERNATIONAL INC.

2. SUMMARY OF THE TEST RESULT

Applied Standard: 47 CFR FCC Part 15 Subpart E				
Part	Rule Section	Description of Test	Result	Under Limit
4.1	15.207	AC Power Line Conducted Emissions	Complies	6.86 dB
4.2	15.407(a)	26dB Spectrum Bandwidth	Complies	-
4.3	15.407(a)	Maximum Conducted Output Power	Complies	0.05 dB
4.4	15.407(a)	Power Spectral Density	Complies	0.01 dB
4.5	15.407(a)	Peak Excursion	Complies	3.31 dB
4.6	15.407(b)	Radiated Emissions	Complies	5.75 dB
4.7	15.407(b)	Band Edge Emissions	Complies	0.62 dB
4.8	15.407(g)	Frequency Stability	Complies	-
4.9	15.203	Antenna Requirements	Complies	-

Test Items	Uncertainty	Remark
AC Power Line Conducted Emissions	±2.3dB	Confidence levels of 95%
Maximum Conducted Output Power	±0.5dB	Confidence levels of 95%
Power Spectral Density	±0.5dB	Confidence levels of 95%
Peak Excursion	±0.5dB	Confidence levels of 95%
26dB Spectrum Bandwidth / Frequency Stability	±8.5×10 ⁻⁸	Confidence levels of 95%
Radiated Emissions (9kHz~30MHz)	±0.8dB	Confidence levels of 95%
Radiated Emissions (30MHz~1000MHz)	±1.9dB	Confidence levels of 95%
Radiated / Band Edge Emissions (1GHz~18GHz)	±1.9dB	Confidence levels of 95%
Radiated Emissions (18GHz~40GHz)	±1.9dB	Confidence levels of 95%
Temperature	±0.7°C	Confidence levels of 95%
Humidity	±3.2%	Confidence levels of 95%
DC / AC Power Source	±1.4%	Confidence levels of 95%

3. GENERAL INFORMATION

3.1. Product Details

IEEE 802.11n/ac

Items	Description
Product Type	WLAN (1TX, 2RX / 2TX, 2RX)
Radio Type	Intentional Transceiver
Power Type	From Host System
Modulation	see the below table for IEEE 802.11n see the below table for IEEE 802.11ac
Data Modulation	OFDM (BPSK / QPSK / 16QAM / 64QAM) For 802.11n OFDM (BPSK / QPSK / 16QAM / 64QAM / 256QAM) For 802.11ac
Data Rate (Mbps)	see the below table for IEEE 802.11n see the below table for IEEE 802.11ac
Frequency Range	5150 ~ 5250MHz
Channel Number	4 for 20MHz bandwidth ; 2 for 40MHz bandwidth 1 for 80MHz bandwidth
Channel Band Width (99%)	11n MCS0 (HT 20MHz): 17.92 MHz ; 11n MCS0 (HT40 MHz): 36.48 MHz; 11n MCS8 (HT 20MHz): 17.92 MHz ; 11n MCS8 (HT40 MHz): 36.48 MHz; 11ac MCS0-Nss1 (VHT 20MHz): 17.92 MHz ; 11ac MCS0-Nss1 (VHT40 MHz): 36.48 MHz; 11ac MCS0-Nss1 (VHT 80MHz): 76.16 MHz; 11ac MCS0-Nss2 (VHT 20MHz): 17.92 MHz ; 11ac MCS0-Nss2 (VHT40 MHz): 36.48 MHz; 11ac MCS0-Nss2 (VHT 80MHz): 76.16 MHz
Maximum Conducted Output Power	11n MCS0 (HT20 MHz): 16.15 dBm ; 11n MCS0 (HT40 MHz): 16.85 dBm; 11n MCS8 (HT20 MHz): 16.95 dBm ; 11n MCS8 (HT40 MHz): 16.94 dBm; 11ac MCS0-Nss1 (VHT20 MHz): 16.17 dBm ; 11ac MCS0-Nss1 (VHT40 MHz): 16.89 dBm; 11ac MCS0-Nss1 (VHT 80MHz): 13.19 dBm 11ac MCS0-Nss2 (VHT20 MHz): 16.86 dBm ; 11ac MCS0-Nss2 (VHT40 MHz): 16.94 dBm; 11ac MCS0-Nss2 (VHT 80MHz): 13.70 dBm
Carrier Frequencies	Please refer to section 3.4
Antenna	Please refer to section 3.3

IEEE 802.11a

Items	Description
Product Type	WLAN (1TX, 2RX)
Radio Type	Intentional Transceiver
Power Type	From Host System
Modulation	OFDM for IEEE 802.11a
Data Modulation	OFDM (BPSK / QPSK / 16QAM / 64QAM)
Data Rate (Mbps)	OFDM (6/9/12/18/24/36/48/54)
Frequency Range	5150 ~ 5250MHz
Channel Number	11a: 4
Channel Band Width (99%)	11a: 16.80 MHz
Maximum Conducted Output Power	11a: 16.21 dBm
Carrier Frequencies	Please refer to section 3.4
Antenna	Please refer to section 3.3

Antenna & Band width

Antenna	Single (TX)			Two (TX)		
	20 MHz	40 MHz	80 MHz	20 MHz	40 MHz	80 MHz
Band width Mode						
IEEE 802.11a	V	X	X	X	X	X
IEEE 802.11b	V	X	X	X	X	X
IEEE 802.11g	V	X	X	X	X	X
IEEE 802.11n	V	V	X	V	V	X
IEEE 802.11ac	V	V	V	V	V	V

IEEE 802.11n spec

MCS Index	Nss	Modulation	R	NBPS	NCBPS		NDBPS		Datarate(Mbps)			
					20MHz	40MHz	20MHz	40MHz	800nsGI		400nsGI	
									20MHz	40MHz	20MHz	40MHz
0	1	BPSK	1/2	1	52	108	26	54	6.5	13.5	7.200	15
1	1	QPSK	1/2	2	104	216	52	108	13.0	27.0	14.400	30
2	1	QPSK	3/4	2	104	216	78	162	19.5	40.5	21.700	45
3	1	16-QAM	1/2	4	208	432	104	216	26.0	54.0	28.900	60
4	1	16-QAM	3/4	4	208	432	156	324	39.0	81.0	43.300	90
5	1	64-QAM	2/3	6	312	648	208	432	52.0	108.0	57.800	120
6	1	64-QAM	3/4	6	312	648	234	486	58.5	121.5	65.000	135
7	1	64-QAM	5/6	6	312	648	260	540	65.0	135.0	72.200	150
8	2	BPSK	1/2	1	104	216	52	108	13.0	27.0	14.444	30
9	2	QPSK	1/2	2	208	432	104	216	26.0	54.0	28.889	60
10	2	QPSK	3/4	2	208	432	156	324	39.0	81.0	43.333	90
11	2	16-QAM	1/2	4	416	864	208	432	52.0	108.0	57.778	120
12	2	16-QAM	3/4	4	416	864	312	648	78.0	162.0	86.667	180
13	2	64-QAM	2/3	6	624	1296	416	864	104.0	216.0	115.556	240
14	2	64-QAM	3/4	6	624	1296	468	972	117.0	243.0	130.000	270
15	2	64-QAM	5/6	6	624	1296	520	1080	130.0	270.0	144.444	300

Symbol	Explanation
NSS	Number of spatial streams
R	Code rate
NBPS	Number of coded bits per single carrier
NCBPS	Number of coded bits per symbol
NDBPS	Number of data bits per symbol
GI	guard interval

IEEE 802. 11a, 11n and 11ac Spec.

Worst Modulation Used for Conformance Testing				
IEEE 802.11 Protocol	Number of Transmit Chains (N _{TX})	Data Rate / MCS	Worst Data Rate / MCS	Worst Modulation Mode
a	1	6-54 Mbps	6Mbps	11A5.2G-20M
n (HT20)	1/2	MCS 0-15	MCS0/MCS8	11N5.2G-20M
n (HT40)	1/2	MCS 0-15	MCS0/MCS8	11N5.2G-40M
ac (VHT20)	1/2	MCS 0-9	MCS0-Nss1/ MCS0-Nss2	11AC5.2G-20M
ac (VHT40)	1/2	MCS 0-9	MCS0-Nss1/ MCS0-Nss2	11AC5.2G-40M
ac (VHT80)	1/2	MCS 0-9	MCS0-Nss1/ MCS0-Nss2	11AC5.2G-80M
Note 1: IEEE 802.11 modulation consists of IEEE 802.11a.				
Note 2: IEEE 802.11n modulation consists of HT20 and HT40 (HT: High Throughput). Then EUT support HT20 and HT40. Worst modulation mode of Guard Interval (GI) is 400ns.				
Note 3: IEEE 802.11ac modulation consists of VHT20, VHT40, VHT80 and VHT160. Then EUT support VHT80. (VHT: Very High Throughput).				

3.2. Accessories

N/A

3.3. Table for Filed Antenna

Ant.	Brand	Model Name	Antenna Type	Connector	Gain (dBi)		Remark
					2.4GHz	5GHz	
1	LYNwave	ALA110-222050-300010	PIFA Antenna	I-PEX	3.5	5	TX/RX
2	LYNwave	ALA110-222050-300010	PIFA Antenna	I-PEX	3.5	5	TX/RX

Note: The EUT has two Chains.

For IEEE 802.11a mode (1TX, 2RX):

The EUT supports 1TX/2RX function, and it supports TX diversity function.

Both Chain 1 and Chain 2 could be used as transmitting antenna, but Chain 1 and Chain 2 could receive simultaneously.

Only the higher gain antenna "Chain 1" was tested and recorded in the report.

For IEEE 802.11n mode (1TX, 2RX / 2TX, 2RX):

1. For 1TX, 2RX function (MCS0~7):

The EUT supports TX diversity function.

Both Chain 1 and Chain 2 could be used as transmitting antenna, but Chain 1 and Chain 2 could receive simultaneously.

Only the higher gain antenna "Chain 1" was tested and recorded in the report.

2. For 2TX, 2RX function (MCS8~15):

Both Chain 1 and Chain 2 could be used as transmitting/receiving antenna.

Chain 1 and Chain 2 could transmitting/receiving simultaneously.

For IEEE 802.11ac mode (1TX, 2RX / 2TX, 2RX):

1. For 1TX, 2RX function (NSS1 MCS0~9):

The EUT supports TX diversity function.

Both Chain 1 and Chain 2 could be used as transmitting antenna, but Chain 1 and Chain 2 could receive simultaneously.

Only the higher gain antenna "Chain 1" was tested and recorded in the report.

2. For 2TX, 2RX function (NSS2 MCS0~9):

Both Chain 1 and Chain 2 could be used as transmitting/receiving antenna.

Chain 1 and Chain 2 could transmitting/receiving simultaneously.

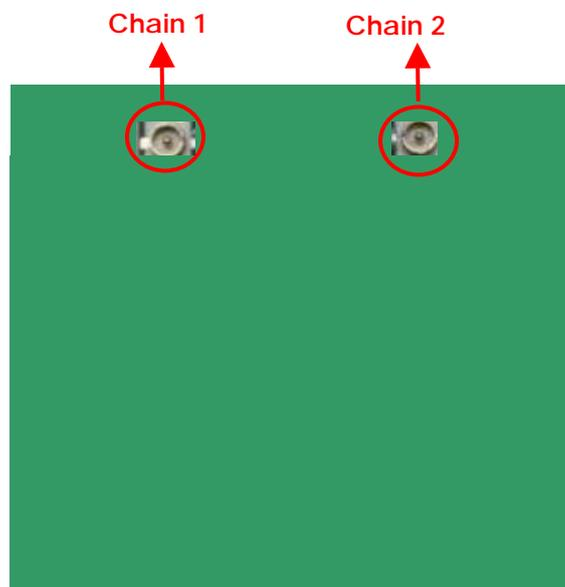

3.4. Table for Carrier Frequencies

The EUT has three bandwidth system.

For 20MHz bandwidth systems, use Channel 36, 40, 44, 48.

For 40MHz bandwidth systems, use Channel 38, 46.

For 80MHz bandwidth systems, use Channel 42.

Frequency Band	Channel No.	Frequency	Channel No.	Frequency
5150~5250 MHz Band 1	36	5180 MHz	44	5220 MHz
	38	5190 MHz	46	5230 MHz
	40	5200 MHz	48	5240 MHz
	42	5210 MHz	-	-

3.5. Table for Test Modes

Preliminary tests were performed in different data rate to find the worst radiated emission. The data rate shown in the table below is the worst-case rate with respect to the specific test item. Investigation has been done on all the possible configurations for searching the worst cases. The following table is a list of the test modes shown in this test report.

Test Items	Mode		Data Rate	Channel	Chain
AC Power Conducted Emission	Normal link		Auto	-	-
Max. Conducted Output Power	11n MCS0 20MHz	Band 1	7.2 Mbps	36/40/48	1
	11n MCS0 40MHz	Band 1	15 Mbps	38/46	1
	11n MCS8 20MHz	Band 1	15 Mbps	36/40/48	1/2/1+2
	11n MCS8 40MHz	Band 1	30 Mbps	38/46	1/2/1+2
	11ac MCS0-Nss1 20MHz	Band 1	7.2 Mbps	36/40/48	1
	11ac MCS0-Nss1 40MHz	Band 1	15 Mbps	38/46	1
	11ac MCS0-Nss2 20MHz	Band 1	15 Mbps	36/40/48	1/2/1+2
	11ac MCS0-Nss2 40MHz	Band 1	30 Mbps	38/46	1/2/1+2
	11ac MCS0-Nss1 80MHz	Band 1	29.3 Mbps	42	1
	11ac MCS0-Nss2 80MHz	Band 1	58.5 Mbps	42	1/2/1+2
	11a	Band 1	6Mbps	36/40/48	1
Power Spectral Density	11n MCS0 20MHz	Band 1	7.2 Mbps	36/40/48	1
	11n MCS0 40MHz	Band 1	15 Mbps	38/46	1
	11n MCS8 20MHz	Band 1	15 Mbps	36/40/48	1/2/1+2
	11n MCS8 40MHz	Band 1	30 Mbps	38/46	1/2/1+2
	11ac MCS0-Nss1 20MHz	Band 1	7.2 Mbps	36/40/48	1
	11ac MCS0-Nss1 40MHz	Band 1	15 Mbps	38/46	1
	11ac MCS0-Nss2 20MHz	Band 1	15 Mbps	36/40/48	1/2/1+2
	11ac MCS0-Nss2 40MHz	Band 1	30 Mbps	38/46	1/2/1+2
	11ac MCS0-Nss1 80MHz	Band 1	29.3 Mbps	42	1
	11ac MCS0-Nss2 80MHz	Band 1	58.5 Mbps	42	1/2/1+2
	11a	Band 1	6Mbps	36/40/48	1
26dB Spectrum Bandwidth 99% Occupied Bandwidth Measurement Peak Excursion	11n MCS0 20MHz	Band 1	7.2 Mbps	36/40/48	1
	11n MCS0 40MHz	Band 1	15 Mbps	38/46	1
	11n MCS8 20MHz	Band 1	15 Mbps	36/40/48	1+2
	11n MCS8 40MHz	Band 1	30 Mbps	38/46	1+2
	11ac MCS0-Nss1 80MHz	Band 1	29.3 Mbps	42	1
	11ac MCS0-Nss2 80MHz	Band 1	58.5 Mbps	42	1+2
	11a	Band 1	6Mbps	36/40/48	1

Radiated Emission Below 1GHz	Normal link		Auto	-	-
Radiated Emission Above 1GHz	11n MCS0 20MHz	Band 1	7.2 Mbps	36/40/48	1
	11n MCS0 40MHz	Band 1	15 Mbps	38/46	1
	11n MCS8 20MHz	Band 1	15 Mbps	36/40/48	1+2
	11n MCS8 40MHz	Band 1	30 Mbps	38/46	1+2
	11ac MCS0-Nss1 80MHz	Band 1	29.3 Mbps	42	1
	11ac MCS0-Nss2 80MHz	Band 1	58.5 Mbps	42	1+2
	11a	Band 1	6Mbps	36/40/48	1
Band Edge Emission	11n MCS0 20MHz	Band 1	7.2 Mbps	36/40/48	1
	11n MCS0 40MHz	Band 1	15 Mbps	38/46	1
	11n MCS8 20MHz	Band 1	15 Mbps	36/40/48	1+2
	11n MCS8 40MHz	Band 1	30 Mbps	38/46	1+2
	11ac MCS0-Nss1 20MHz	Band 1	7.2 Mbps	36/40/48	1
	11ac MCS0-Nss1 40MHz	Band 1	15 Mbps	38/46	1
	11ac MCS0-Nss2 20MHz	Band 1	15 Mbps	36/40/48	1/2/1+2
	11ac MCS0-Nss2 40MHz	Band 1	30 Mbps	38/46	1/2/1+2
	11ac MCS0-Nss1 80MHz	Band 1	29.3 Mbps	42	1
	11ac MCS0-Nss2 80MHz	Band 1	58.5 Mbps	42	1/2/1+2
	11a	Band 1	6Mbps	36/40/48	1
Frequency Stability	Un-modulation		-	40	N/A

3.6. Table for Testing Locations

Test Site No.	Site Category	Location	FCC Reg. No.	IC File No.
03CH01-CB	SAC	Hsin Chu	262045	IC 4086D
CO01-CB	Conduction	Hsin Chu	262045	IC 4086D
TH01-CB	OVEN Room	Hsin Chu	-	-

Open Area Test Site (OATS); Semi Anechoic Chamber (SAC); Fully Anechoic Chamber (FAC).

Please refer section 6 for Test Site Address.

3.7. Table for Supporting Units

Support Unit	Brand	Model	FCC ID
Notebook	DELL	E6220	E2KWM3945ABG
Mouse	iCooky	AMS0706W	DoC
Earphone	SHYARO CHI	MIC-04	N/A
Wireless AP	BELKIN	WG7016G22-LF-AK	DoC

3.8. Table for Parameters of Test Software Setting

During testing, Channel & Power Controlling Software provided by the customer was used to control the operating channel as well as the output power level. The RF output power selection is for the setting of RF output power expected by the customer and is going to be fixed on the firmware of the final end product.

Power Parameters of IEEE 802.11n MCS0 HT20MHz / Chain 1 (1TX)

Test Software Version	Realtek 11ac 8812A PCIE WLAN MP Diagnostic Program 0.0028.20121122		
Frequency	5180 MHz	5200 MHz	5240 MHz
MCS0 20MHz	46	45	44

Power Parameters of IEEE 802.11n MCS0 HT40MHz / Chain 1 (1TX)

Test Software Version	Realtek 11ac 8812A PCIE WLAN MP Diagnostic Program 0.0028.20121122	
Frequency	5190 MHz	5230 MHz
MCS0 40MHz	40	47

Power Parameters of IEEE 802.11n MCS8 HT20MHz / Chain 1 + Chain 2 (2TX)

Test Software Version	Realtek 11ac 8812A PCIE WLAN MP Diagnostic Program 0.0028.20121122		
Frequency	5180 MHz	5200 MHz	5240 MHz
MCS0 20MHz	42/37	41/36	40/35

Power Parameters of IEEE 802.11n MCS8 HT40MHz / Chain 1 + Chain 2 (2TX)

Test Software Version	Realtek 11ac 8812A PCIE WLAN MP Diagnostic Program 0.0028.20121122	
Frequency	5190 MHz	5230 MHz
MCS0 40MHz	38/33	43/38

Power Parameters of IEEE 802.11ac MCS0-Nss1 VHT 20MHz / Chain 1 (1TX)

Test Software Version	Realtek 11ac 8812A PCIE WLAN MP Diagnostic Program 0.0028.20121122		
Frequency	5180 MHz	5200 MHz	5240 MHz
MCS0 20MHz	46	45	44

Power Parameters of IEEE 802.11ac MCS0-Nss1 VHT 40MHz / Chain 1 (1TX)

Test Software Version	Realtek 11ac 8812A PCIE WLAN MP Diagnostic Program 0.0028.20121122	
Frequency	5190 MHz	5230 MHz
MCS0 40MHz	40	47

Power Parameters of IEEE 802.11ac MCS0-Nss1 VHT 80MHz / Chain 1 (1TX)

Test Software Version	Realtek 11ac 8812A PCIE WLAN MP Diagnostic Program 0.0028.20121122
Frequency	5210 MHz
MCS0 80MHz	36

Power Parameters of IEEE 802.11ac MCS0-Nss2 VHT 20MHz / Chain 1 + Chain 2 (2TX)

Test Software Version	Realtek 11ac 8812A PCIE WLAN MP Diagnostic Program 0.0028.20121122		
Frequency	5180 MHz	5200 MHz	5240 MHz
MCS0 20MHz	42/37	41/36	40/35

Power Parameters of IEEE 802.11ac MCS0-Nss2 VHT 40MHz / Chain 1 + Chain 2 (2TX)

Test Software Version	Realtek 11ac 8812A PCIE WLAN MP Diagnostic Program 0.0028.20121122	
Frequency	5190 MHz	5230 MHz
MCS0 40MHz	37/32	43/38

Power Parameters of IEEE 802.11ac MCS0-Nss2 VHT 80MHz / Chain 1 + Chain 2 (2TX)

Test Software Version	Realtek 11ac 8812A PCIE WLAN MP Diagnostic Program 0.0028.20121122
Frequency	5210 MHz
MCS0 80MHz	30/28

Power Parameters of IEEE 802.11a / Chain 1 (1TX)

Test Software Version	Realtek 11ac 8812A PCIE WLAN MP Diagnostic Program 0.0028.20121122		
Frequency	5180 MHz	5200 MHz	5240 MHz
11a	46	45	44

During the test, "Realtek 11ac 8812A PCIE WLAN MP Diagnostic Program 0.0028.20121122" under WIN XP was executed the test program to control the EUT continuously transmit RF signal.

3.9. Test Configurations

3.9.1. Radiation Emissions Test Configuration

Test Configuration: 30 MHz~1GHz

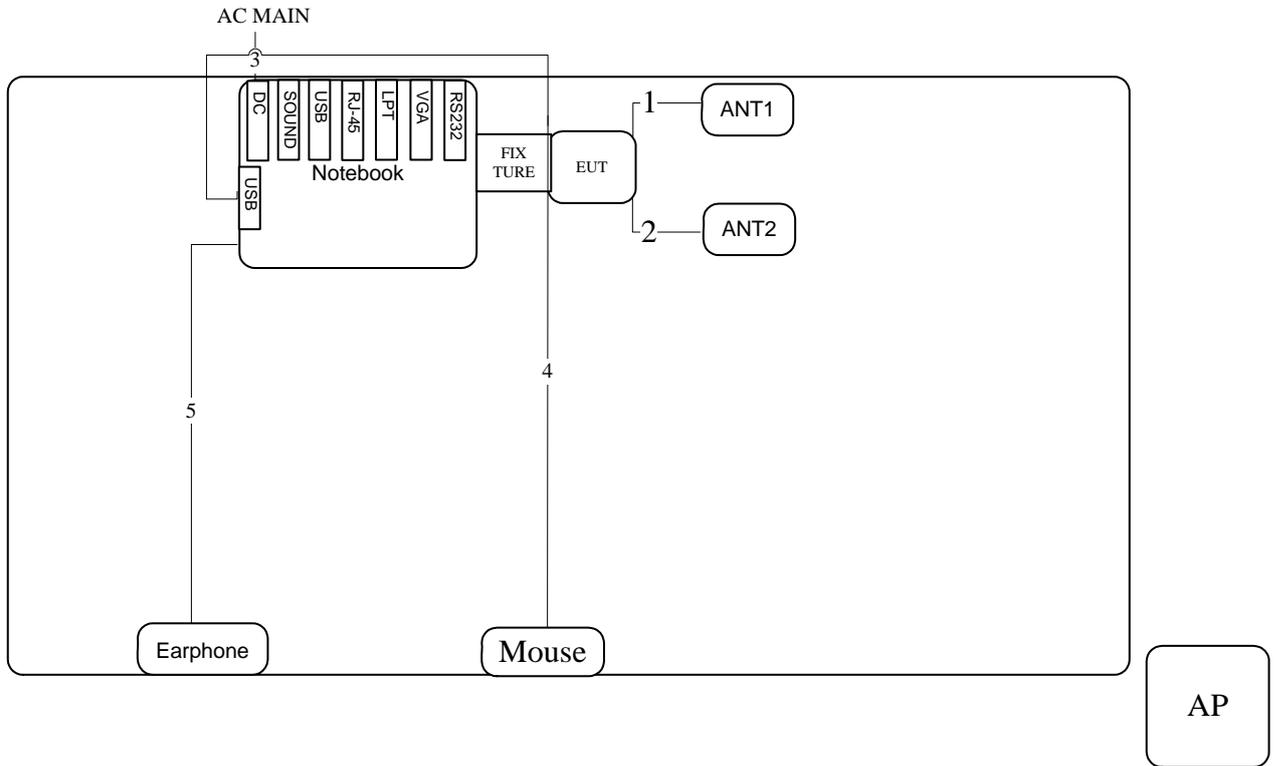

Item	Connection	Shield	Length
1	Ant. Cable	No	0.3m
2	Ant. Cable	No	0.3m
3	Power Cable	No	2.6m
4	USB Cable	No	1.8m
5	Audio Cable	No	1m

Test Configuration: Above 1 GHz

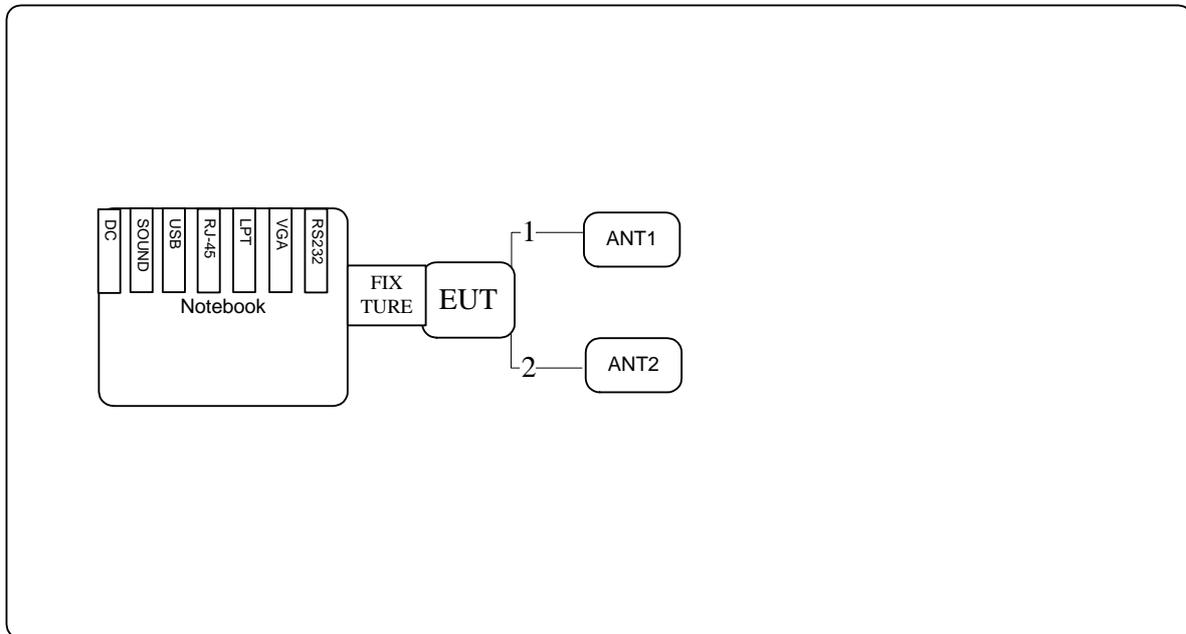

Item	Connection	Shield	Length
1	Ant. Cable	No	0.3m
2	Ant. Cable	No	0.3m

3.9.2. AC Power Line Conduction Emissions Test Configuration

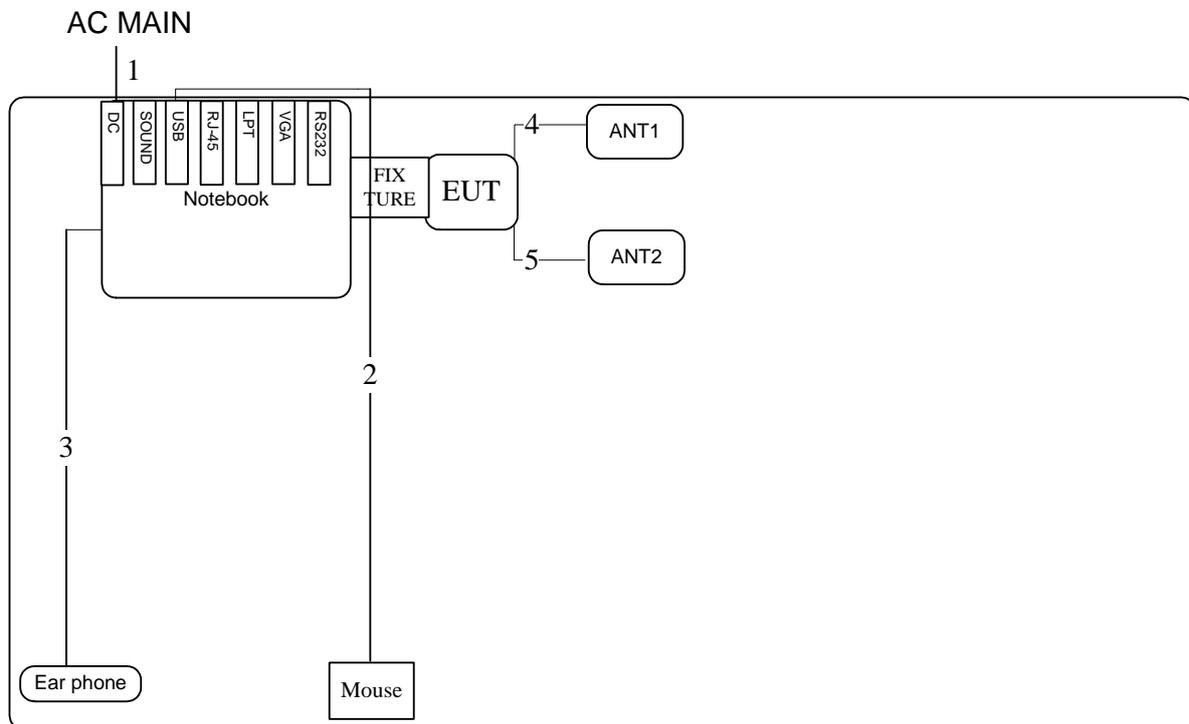

Item	Connection	Shield	Length
1	Power Cable	No	2.6m
2	USB Cable	No	1.8m
3	Audio Cable	No	1.1m
4	Ant. Cable	No	0.3m
5	Ant. Cable	No	0.3m

4. TEST RESULT

4.1. AC Power Line Conducted Emissions Measurement

4.1.1. Limit

For this product that is designed to connect to the AC power line, the radio frequency voltage that is conducted back onto the AC power line on any frequency or frequencies within the band 150 kHz to 30 MHz shall not exceed below limits table.

Frequency (MHz)	QP Limit (dBuV)	AV Limit (dBuV)
0.15~0.5	66~56	56~46
0.5~5	56	46
5~30	60	50

4.1.2. Measuring Instruments and Setting

Please refer to section 5 of equipments list in this report. The following table is the setting of the receiver.

Receiver Parameters	Setting
Attenuation	10 dB
Start Frequency	0.15 MHz
Stop Frequency	30 MHz
IF Bandwidth	9 KHz

4.1.3. Test Procedures

1. Configure the EUT according to ANSI C63.10. The EUT or host of EUT has to be placed 0.4 meter far from the conducting wall of the shielding room and at least 80 centimeters from any other grounded conducting surface.
2. Connect EUT or host of EUT to the power mains through a line impedance stabilization network (LISN).
3. All the support units are connected to the other LISNs. The LISN should provide 50uH/50ohms coupling impedance.
4. The frequency range from 150 KHz to 30 MHz was searched.
5. Set the test-receiver system to Peak Detect Function and Specified Bandwidth with Maximum Hold Mode.
6. The measurement has to be done between each power line and ground at the power terminal.

4.1.4. Test Setup Layout

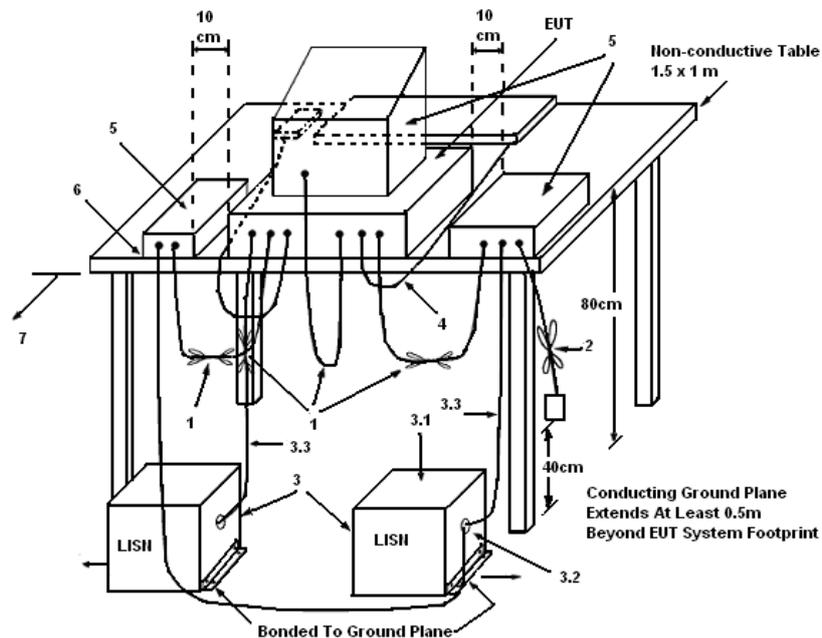

LEGEND:

- (1) Interconnecting cables that hang closer than 40 cm to the ground plane shall be folded back and forth in the center forming a bundle 30 to 40 cm long.
- (2) I/O cables that are not connected to a peripheral shall be bundled in the center. The end of the cable may be terminated, if required, using the correct terminating impedance. The overall length shall not exceed 1 m.
- (3) EUT connected to one LISN. Unused LISN measuring port connectors shall be terminated in 50 Ω . LISN can be placed on top of, or immediately beneath, reference ground plane.
 - (3.1) All other equipment powered from additional LISN(s).
 - (3.2) Multiple outlet strip can be used for multiple power cords of non-EUT equipment.
 - (3.3) LISN at least 80 cm from nearest part of EUT chassis.
- (4) Cables of hand-operated devices, such as keyboards, mice, etc., shall be placed as for normal use.
- (5) Non-EUT components of EUT system being tested.
- (6) Rear of EUT, including peripherals, shall all be aligned and flush with rear of tabletop.
- (7) Rear of tabletop shall be 40 cm removed from a vertical conducting plane that is bonded to the ground plane.

4.1.5. Test Deviation

There is no deviation with the original standard.

4.1.6. EUT Operation during Test

The EUT was placed on the test table and programmed in normal function.

4.1.7. Results of AC Power Line Conducted Emissions Measurement

Temperature	24°C	Humidity	55%
Test Engineer	Justin Chiu	Phase	Line
Configuration	Normal Link		

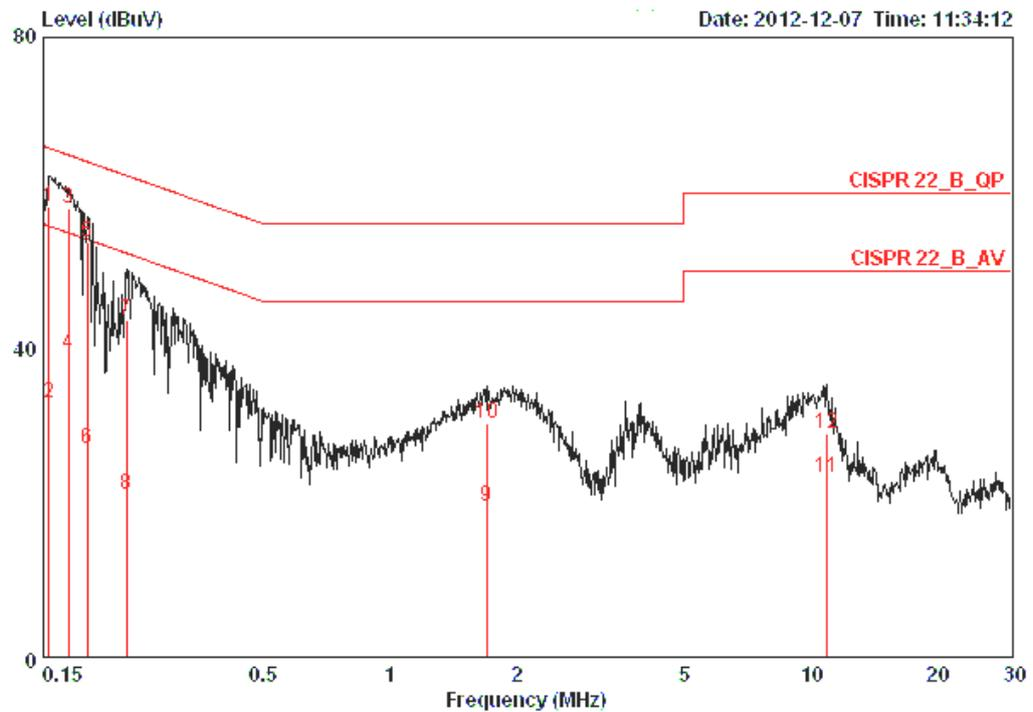

	Freq	Level	Over Limit	Limit Line	Read Level	LISN Factor	Cable Loss	Pol/Phase	Remark
	MHz	dBuV	dB	dBuV	dBuV	dB	dB		
1	0.15440	58.26	-7.50	65.76	58.00	0.08	0.18	LINE	QP
2	0.15440	32.87	-22.89	55.76	32.61	0.08	0.18	LINE	AVERAGE
3	0.17215	58.00	-6.86	64.86	57.73	0.08	0.19	LINE	QP
4	0.17215	39.22	-15.64	54.86	38.95	0.08	0.19	LINE	AVERAGE
5	0.19039	53.61	-10.41	64.02	53.33	0.08	0.20	LINE	QP
6	0.19039	27.01	-27.01	54.02	26.73	0.08	0.20	LINE	AVERAGE
7	0.23658	43.67	-18.55	62.22	43.39	0.08	0.20	LINE	QP
8	0.23658	21.18	-31.04	52.22	20.90	0.08	0.20	LINE	AVERAGE
9	1.698	19.53	-26.47	46.00	19.20	0.10	0.22	LINE	AVERAGE
10	1.698	30.28	-25.72	56.00	29.95	0.10	0.22	LINE	QP
11	10.905	23.37	-26.63	50.00	22.74	0.25	0.38	LINE	AVERAGE
12	10.905	28.93	-31.07	60.00	28.30	0.25	0.38	LINE	QP

Temperature	24°C	Humidity	55%
Test Engineer	Justin Chiu	Phase	Neutral
Configuration	Normal Link		

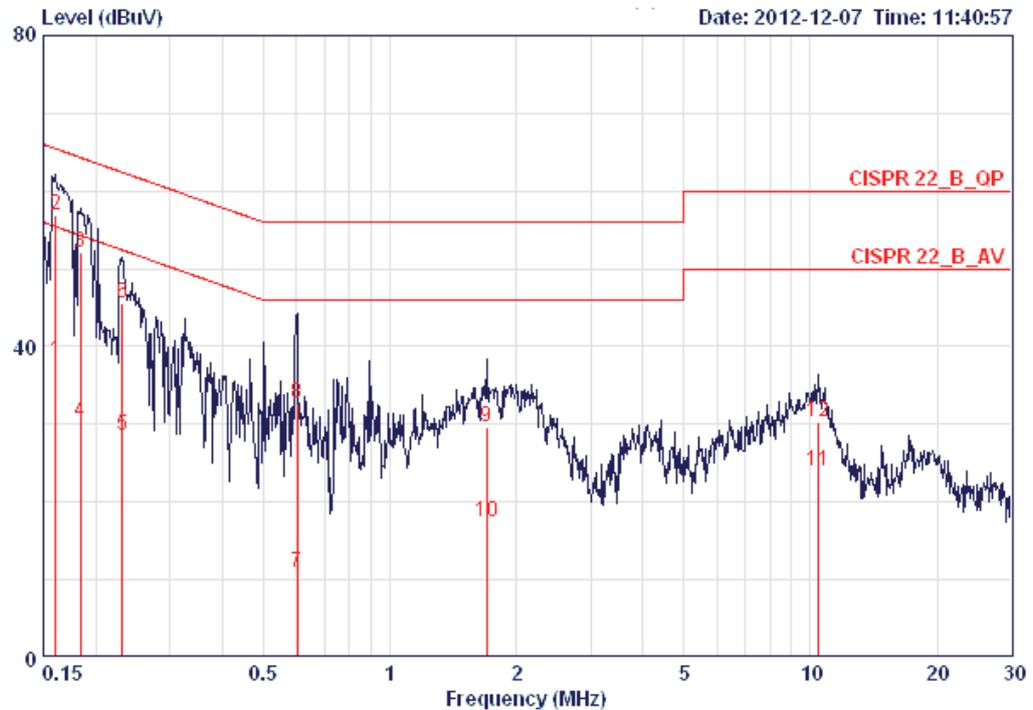

	Freq	Level	Over Limit	Limit Line	Read Level	LISN Factor	Cable Loss	Pol/Phase	Remark
	MHz	dBuV	dB	dBuV	dBuV	dB	dB		
1	0.16070	38.07	-17.35	55.43	37.81	0.08	0.18	NEUTRAL	AVERAGE
2	0.16070	56.82	-8.60	65.43	56.56	0.08	0.18	NEUTRAL	QP
3	0.18346	52.11	-12.21	64.33	51.84	0.08	0.19	NEUTRAL	QP
4	0.18346	30.24	-24.08	54.33	29.97	0.08	0.19	NEUTRAL	AVERAGE
5	0.23162	28.64	-23.75	52.39	28.36	0.08	0.20	NEUTRAL	AVERAGE
6	0.23162	45.52	-16.87	62.39	45.24	0.08	0.20	NEUTRAL	QP
7	0.60112	10.97	-35.03	46.00	10.69	0.08	0.20	NEUTRAL	AVERAGE
8	0.60112	32.76	-23.24	56.00	32.48	0.08	0.20	NEUTRAL	QP
9	1.698	29.54	-26.46	56.00	29.21	0.10	0.22	NEUTRAL	QP
10	1.698	17.54	-28.46	46.00	17.21	0.10	0.22	NEUTRAL	AVERAGE
11	10.397	24.07	-25.93	50.00	23.46	0.25	0.36	NEUTRAL	AVERAGE
12	10.397	30.29	-29.71	60.00	29.68	0.25	0.36	NEUTRAL	QP

Note:

Level = Read Level + LISN Factor + Cable Loss.

4.2. 99% Occupied Bandwidth Measurement

4.2.1. Limit

No restriction limits. But resolution bandwidth within band edge measurement is 1% of the 99% occupied bandwidth.

4.2.2. Measuring Instruments and Setting

Please refer to section 5 of equipments list in this report. The following table is the setting of the spectrum analyzer.

Spectrum Parameters	Setting
Attenuation	Auto
Span Frequency	> 26dB Bandwidth
RB	300 kHz
VB	3000 kHz
Detector	Peak
Trace	Max Hold
Sweep Time	Auto

4.2.3. Test Procedures

1. The transmitter output (antenna port) was connected to the spectrum analyzer in peak hold mode.
2. The resolution bandwidth of 300 kHz and the video bandwidth of 1000 kHz were used.
3. Measured the spectrum width with power higher than 26dB below carrier.

4.2.4. Test Setup Layout

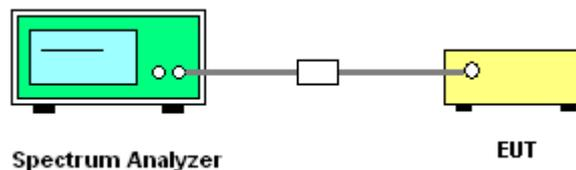

4.2.5. Test Deviation

There is no deviation with the original standard.

4.2.6. EUT Operation during Test

The EUT was programmed to be in continuously transmitting mode.

4.2.7. Test Result of 99% Occupied Bandwidth

Temperature	25°C	Humidity	56%
Test Engineer	Benson Peng	Configurations	IEEE 802.11n/ac

Configuration IEEE 802.11n MCS0 HT 20MHz / Chain 1 (1TX)

Channel	Frequency	26dB Bandwidth (MHz)	99% Occupied Bandwidth (MHz)
36	5180 MHz	21.28	17.92
40	5200 MHz	21.44	17.92
48	5240 MHz	21.44	17.92

Configuration IEEE 802.11n MCS0 HT 40MHz / Chain 1 (1TX)

Channel	Frequency	26dB Bandwidth (MHz)	99% Occupied Bandwidth (MHz)
38	5190 MHz	41.92	36.48
46	5230 MHz	41.60	36.48

Configuration IEEE 802.11n MCS8 HT 20MHz / Chain 1 + Chain 2 (2TX)

Channel	Frequency	26dB Bandwidth (MHz)	99% Occupied Bandwidth (MHz)
36	5180 MHz	20.48	17.60
40	5200 MHz	20.48	17.92
48	5240 MHz	20.64	17.92

Configuration IEEE 802.11n MCS8 HT 40MHz / Chain 1 + Chain 2 (2TX)

Channel	Frequency	26dB Bandwidth (MHz)	99% Occupied Bandwidth (MHz)
38	5190 MHz	41.60	36.48
46	5230 MHz	41.28	36.48

Configuration IEEE 802.11ac MCS0-Nss1 VHT 20MHz / Chain 1 (1TX)

Channel	Frequency	26dB Bandwidth (MHz)	99% Occupied Bandwidth (MHz)
36	5180 MHz	21.44	17.92
40	5200 MHz	21.28	17.92
48	5240 MHz	21.44	17.92

Configuration IEEE 802.11ac MCS0-Nss1 VHT 40MHz / Chain 1 (1TX)

Channel	Frequency	26dB Bandwidth (MHz)	99% Occupied Bandwidth (MHz)
38	5190 MHz	41.28	36.48
46	5230 MHz	41.92	36.48

Configuration IEEE 802.11ac MCS0-Nss1 VHT 80MHz / Chain 1 (1TX)

Channel	Frequency	26dB Bandwidth (MHz)	99% Occupied Bandwidth (MHz)
42	5210 MHz	82.56	76.16

Configuration IEEE 802.11ac MCS0-Nss2 VHT 20MHz / Chain 1 + Chain 2 (2TX)

Channel	Frequency	26dB Bandwidth (MHz)	99% Occupied Bandwidth (MHz)
36	5180 MHz	20.48	17.92
40	5200 MHz	20.80	17.92
48	5240 MHz	20.64	17.60

Configuration IEEE 802.11ac MCS0-Nss2 VHT 40MHz / Chain 1 + Chain 2 (2TX)

Channel	Frequency	26dB Bandwidth (MHz)	99% Occupied Bandwidth (MHz)
38	5190 MHz	40.64	36.48
46	5230 MHz	41.60	36.48

Configuration IEEE 802.11ac MCS0-Nss2 VHT 80MHz / Chain 1 + Chain 2 (2TX)

Channel	Frequency	26dB Bandwidth (MHz)	99% Occupied Bandwidth (MHz)
42	5210 MHz	81.92	76.16

Temperature	25°C	Humidity	56%
Test Engineer	Benson Peng	Configurations	IEEE 802.11a

Configuration IEEE 802.11a / Chain 1 (1TX)

Channel	Frequency	26dB Bandwidth (MHz)	99% Occupied Bandwidth (MHz)
36	5180 MHz	20.64	16.80
40	5200 MHz	20.64	16.80
48	5240 MHz	20.80	16.80

26 dB Bandwidth Plot on Configuration IEEE 802.11n MCS0 HT20MHz / 5180 MHz / Chain 1 (1TX)

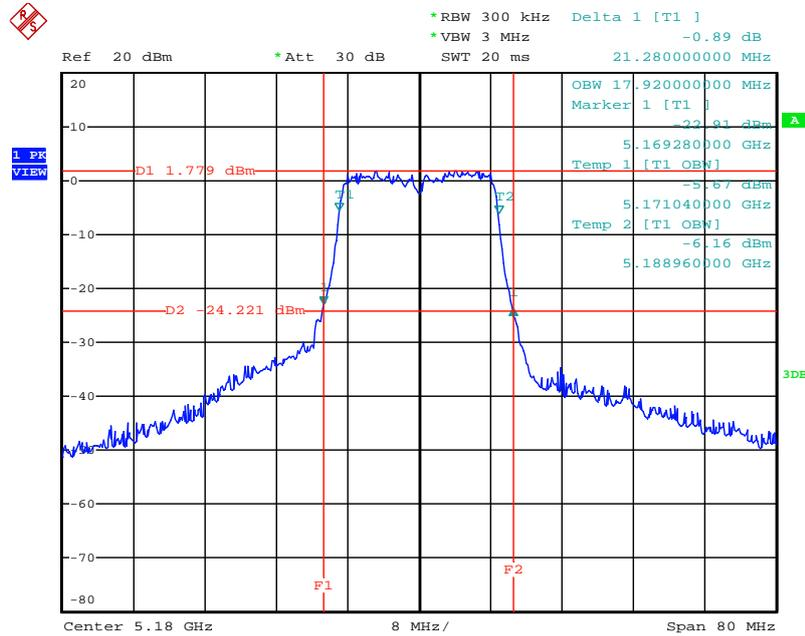

Date: 12.DEC.2012 22:40:33

26 dB Bandwidth Plot on Configuration IEEE 802.11n MCS0 HT20MHz / 5200 MHz / Chain 1 (1TX)

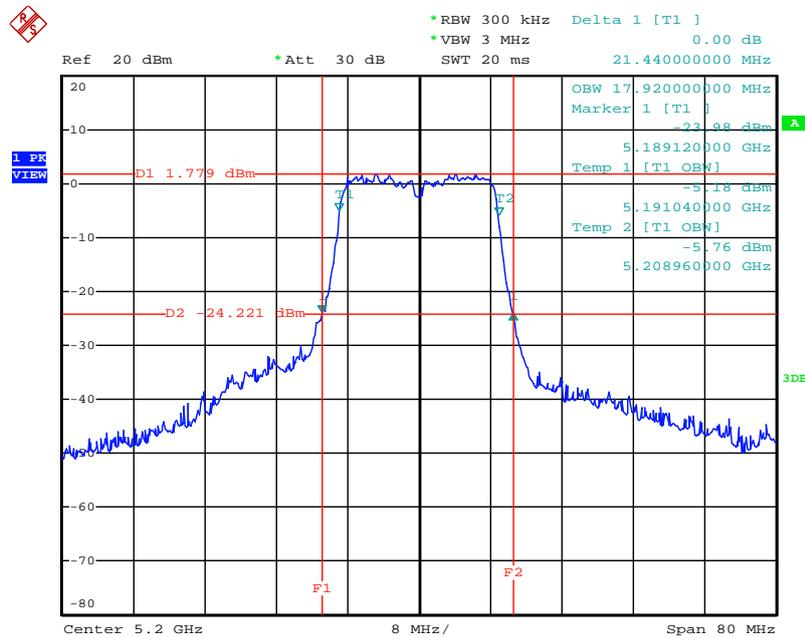

Date: 12.DEC.2012 22:40:10

26 dB Bandwidth Plot on Configuration IEEE 802.11n MCS0 HT20MHz / 5240 MHz / Chain 1 (1TX)

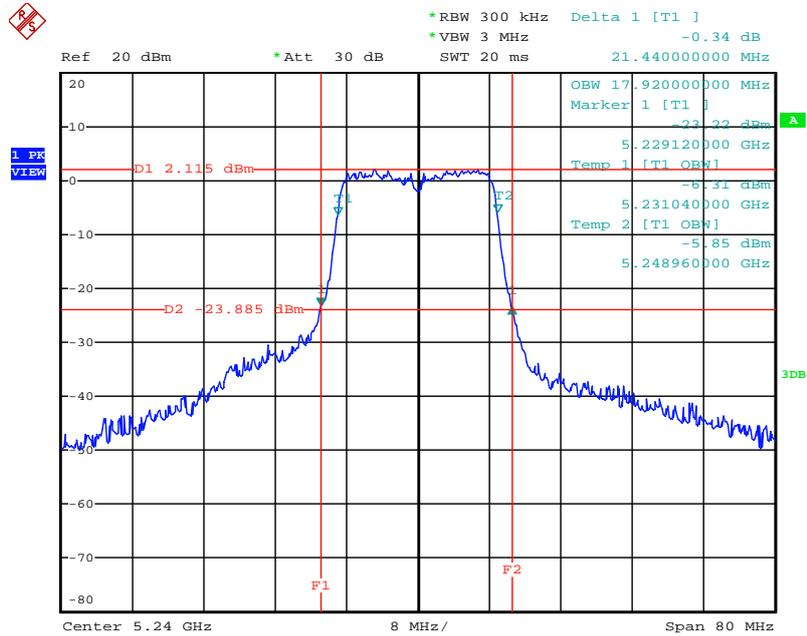

Date: 12.DEC.2012 22:39:45

26 dB Bandwidth Plot on Configuration IEEE 802.11n MCS0 HT40MHz / 5190 MHz / Chain 1 (1TX)

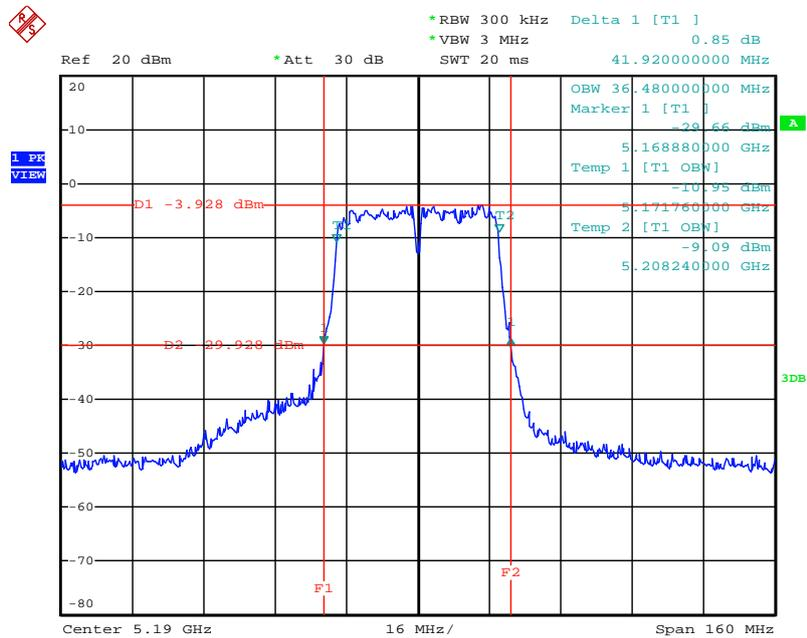

Date: 12.DEC.2012 22:41:14

26 dB Bandwidth Plot on Configuration IEEE 802.11n MCS0 HT40MHz / 5230 MHz / Chain 1 (1TX)

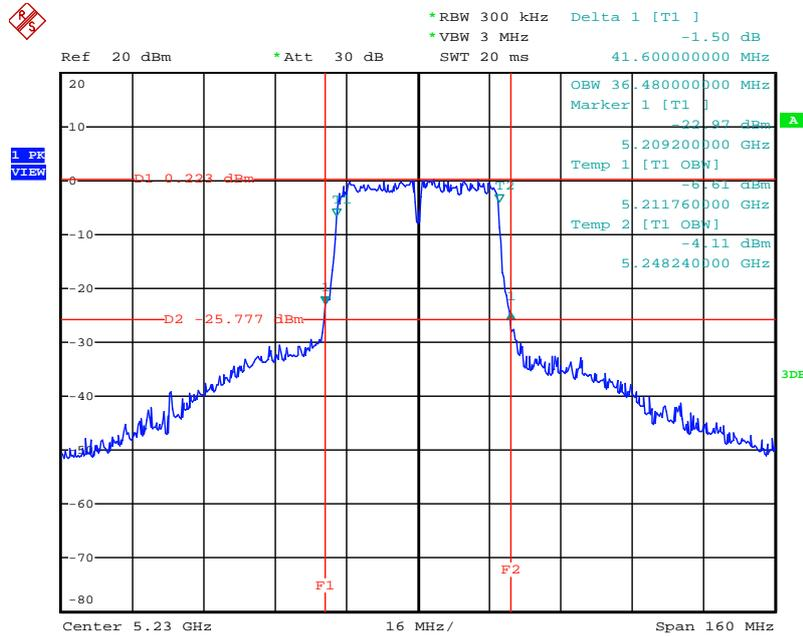

Date: 12.DEC.2012 22:41:47

26 dB Bandwidth Plot on Configuration IEEE 802.11n MCS8 HT20MHz / 5180 MHz / Chain 1 + Chain 2 (2TX)

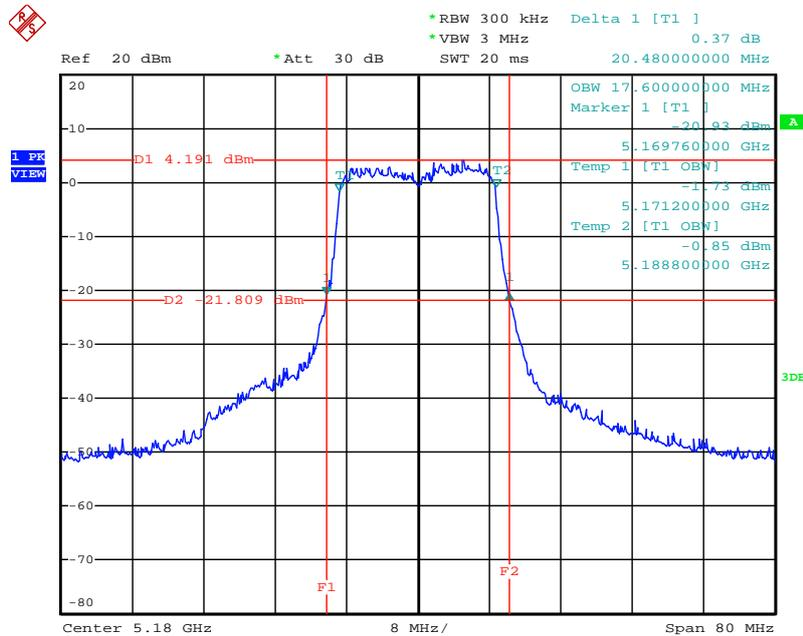

Date: 12.DEC.2012 22:51:27

26 dB Bandwidth Plot on Configuration IEEE 802.11n MCS8 HT20MHz / 5200 MHz / Chain 1 + Chain 2 (2TX)

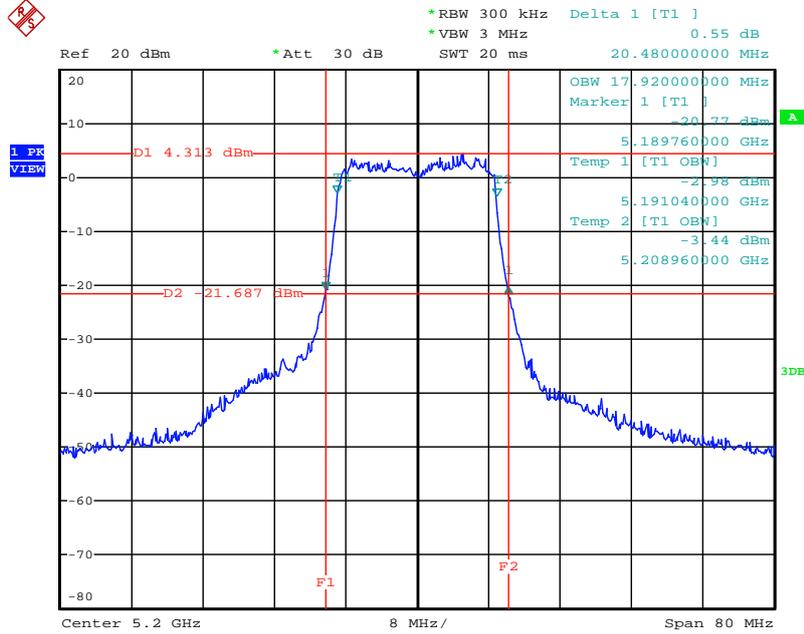

Date: 12.DEC.2012 22:51:00

26 dB Bandwidth Plot on Configuration IEEE 802.11n MCS8 HT20MHz / 5240 MHz / Chain 1 + Chain 2 (2TX)

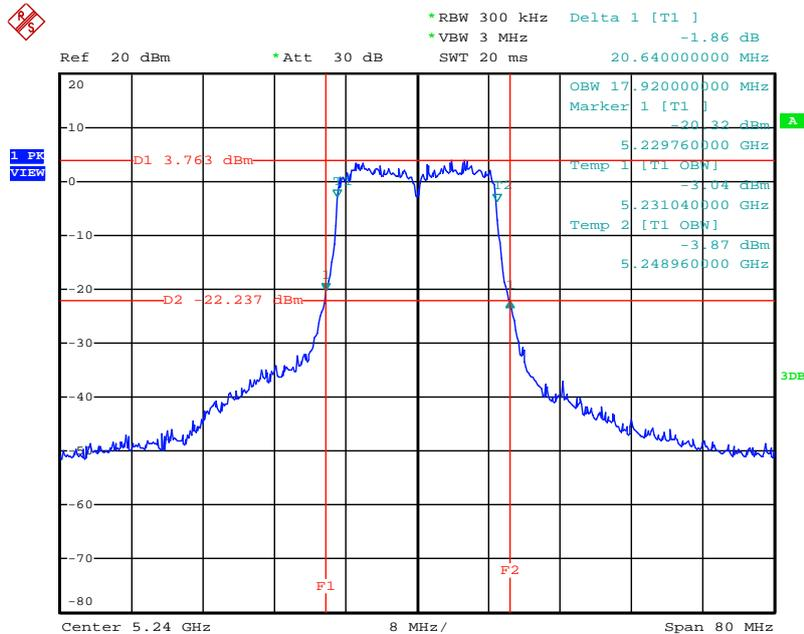

Date: 12.DEC.2012 22:50:32

26 dB Bandwidth Plot on Configuration IEEE 802.11n MCS8 HT40MHz / 5190 MHz / Chain 1 + Chain 2 (2TX)

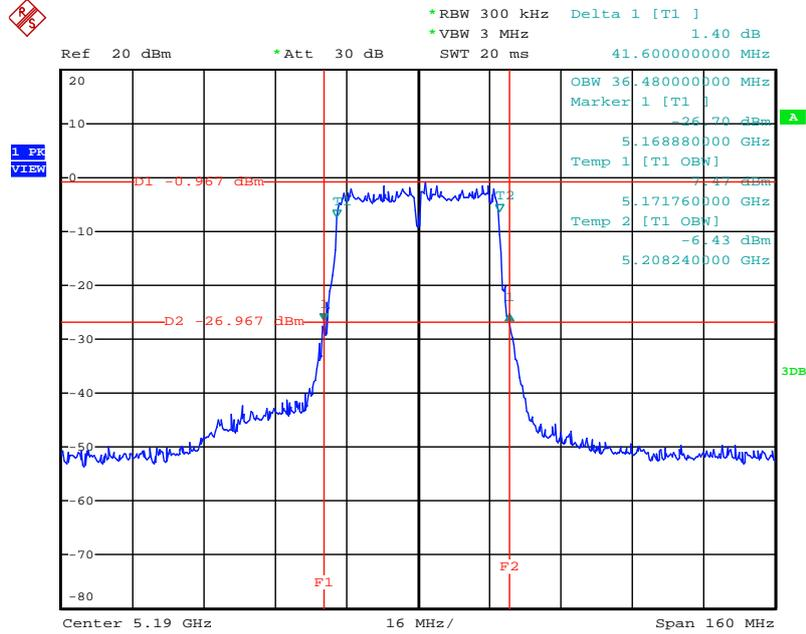

Date: 12.DEC.2012 22:52:09

26 dB Bandwidth Plot on Configuration IEEE 802.11n MCS8 HT40MHz / 5230 MHz / Chain 1 + Chain 2 (2TX)

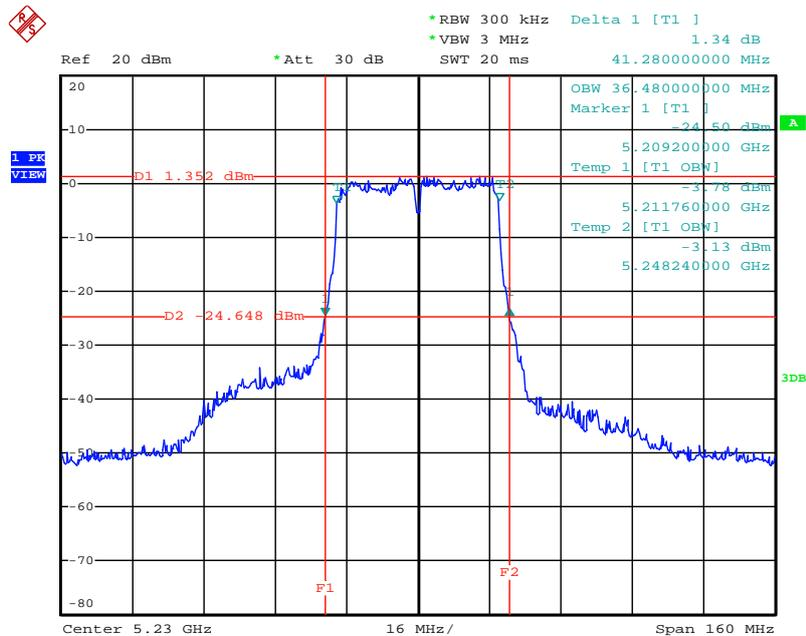

Date: 12.DEC.2012 22:52:47

26 dB Bandwidth Plot on Configuration IEEE 802.11ac MCS0-Nss1 VHT20MHz / 5180 MHz / Chain 1 (1TX)

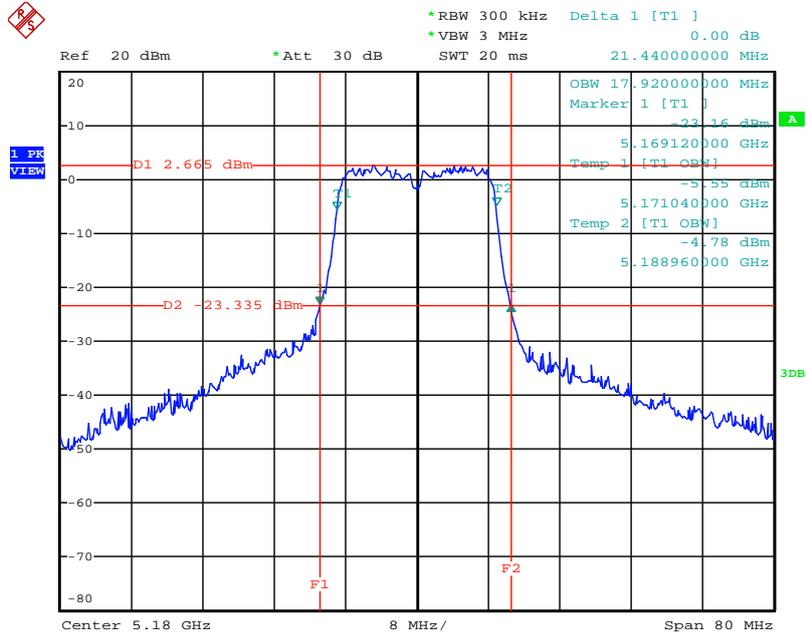

Date: 12.DEC.2012 22:43:48

26 dB Bandwidth Plot on Configuration IEEE 802.11ac MCS0-Nss1 VHT20MHz / 5200 MHz / Chain 1 (1TX)

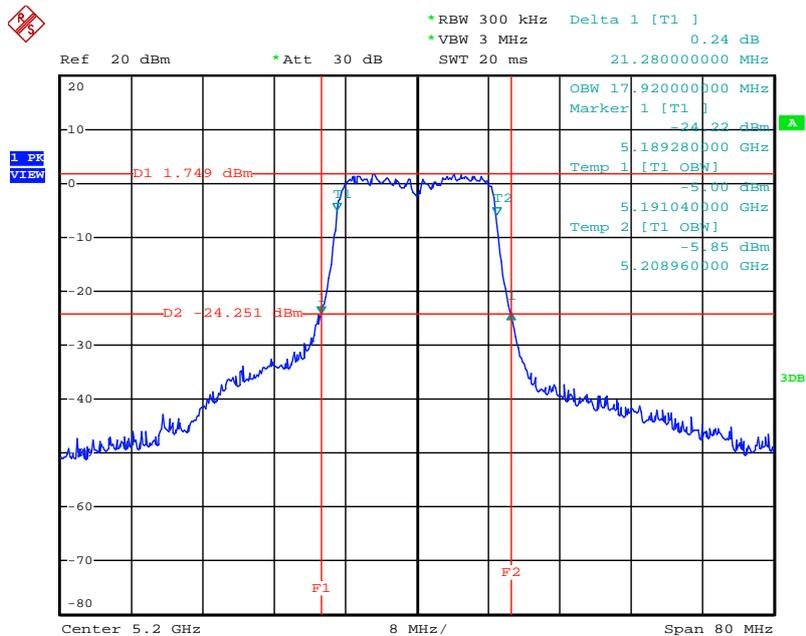

Date: 12.DEC.2012 22:44:15

26 dB Bandwidth Plot on Configuration IEEE 802.11ac MCS0-Nss1 VHT20MHz / 5240 MHz / Chain 1 (1TX)

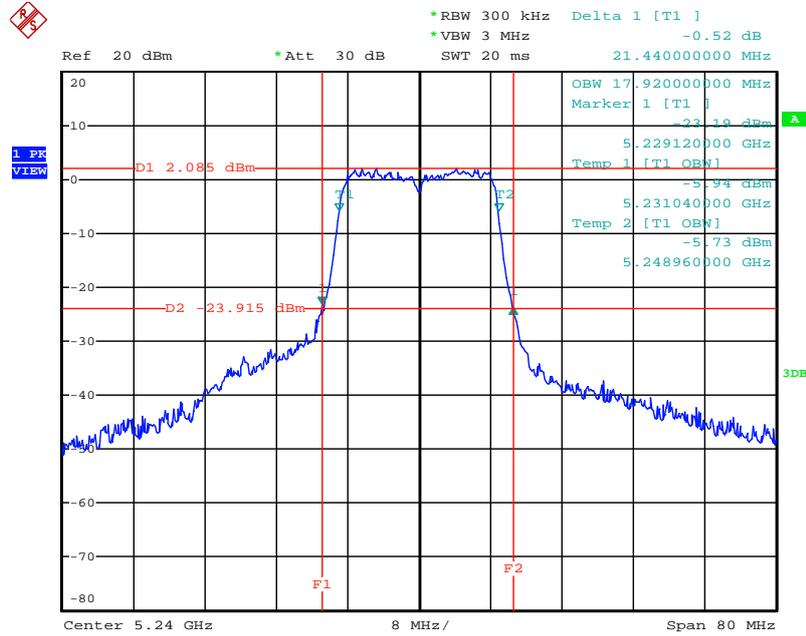

Date: 12.DEC.2012 22:44:44

26 dB Bandwidth Plot on Configuration IEEE 802.11ac MCS0-Nss1 VHT40MHz / 5190 MHz / Chain 1 (1TX)

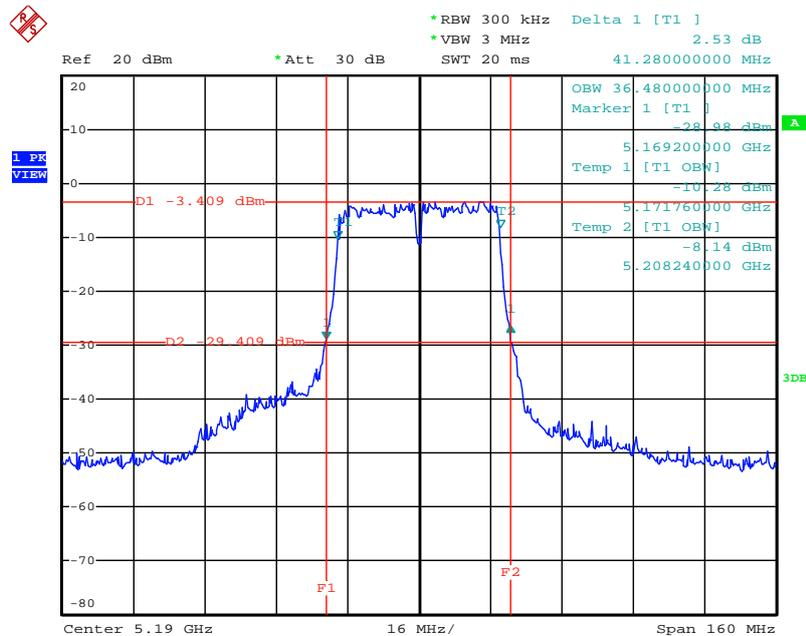

Date: 12.DEC.2012 22:43:06

26 dB Bandwidth Plot on Configuration IEEE 802.11ac MCS0-Nss1 HT40MHz / 5230 MHz / Chain 1 (1TX)

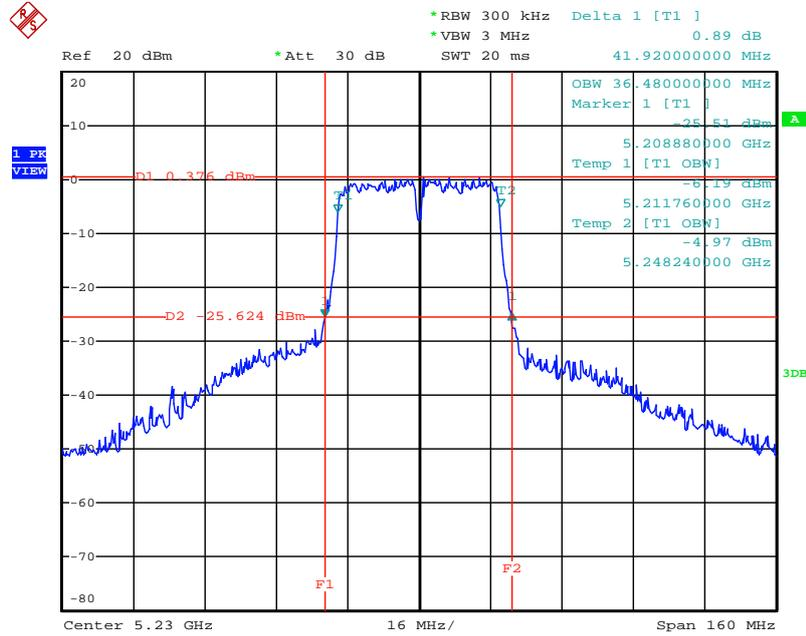

Date: 12.DEC.2012 22:42:24

26 dB Bandwidth Plot on Configuration IEEE 802.11ac MCS0-Nss2 VHT20MHz / 5180 MHz / Chain 1 + Chain 2 (2TX)

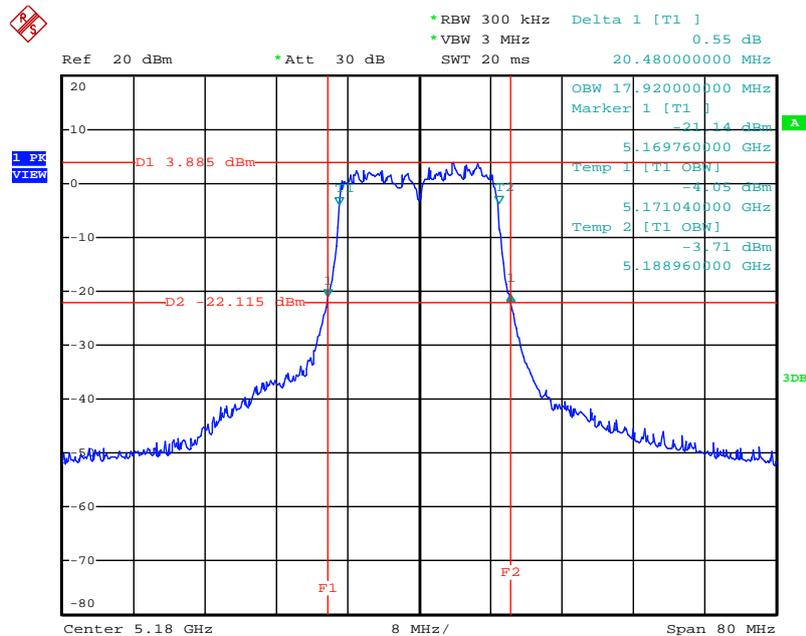

Date: 12.DEC.2012 22:48:44

26 dB Bandwidth Plot on Configuration IEEE 802.11ac MCS0-Nss2 VHT20MHz / 5200 MHz / Chain 1 + Chain 2 (2TX)

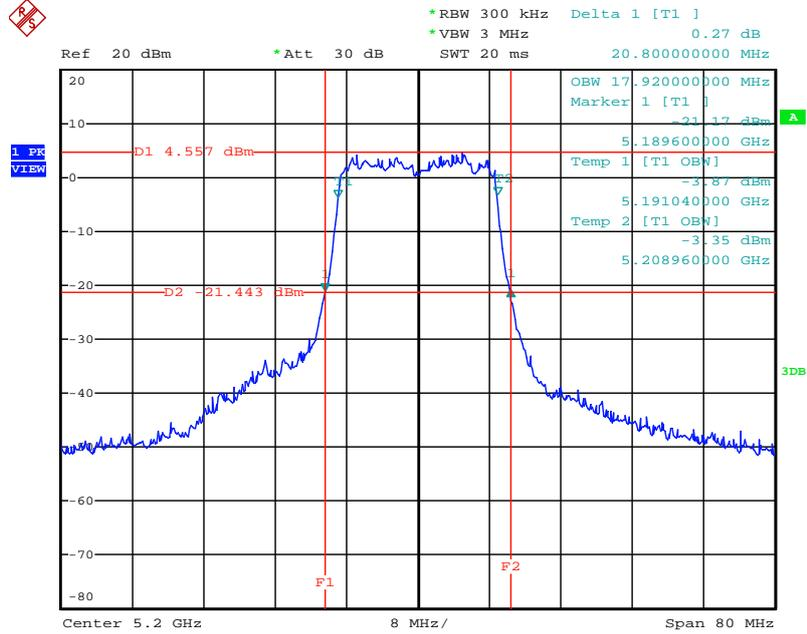

Date: 12.DEC.2012 22:49:14

26 dB Bandwidth Plot on Configuration IEEE 802.11ac MCS0-Nss2 VHT20MHz / 5240 MHz / Chain 1 + Chain 2 (2TX)

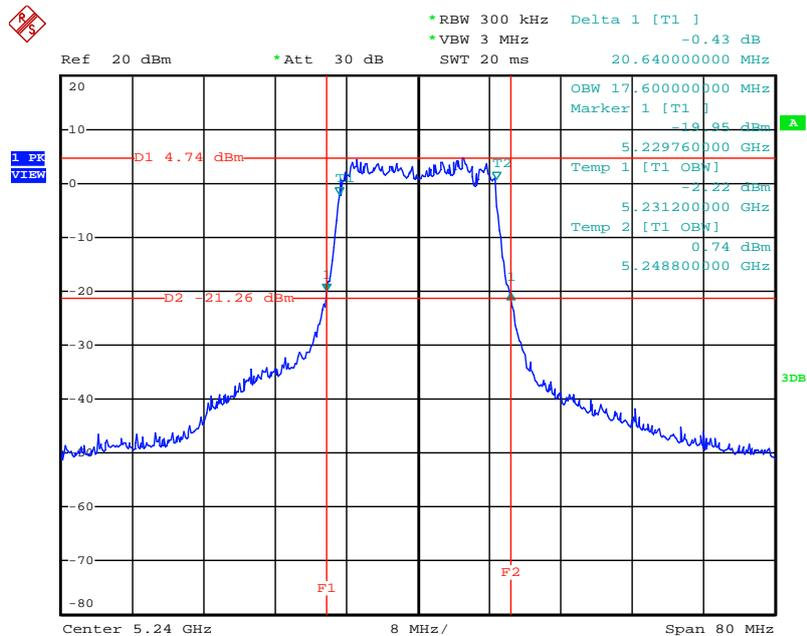

Date: 12.DEC.2012 22:49:49

26 dB Bandwidth Plot on Configuration IEEE 802.11ac MCS0-Nss2 VHT40MHz / 5190 MHz / Chain 1 + Chain 2 (2TX)

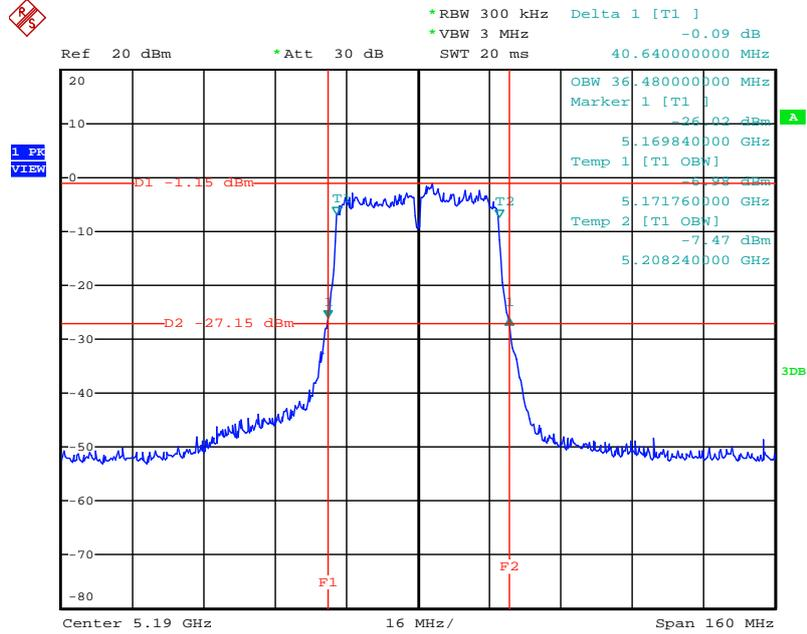

Date: 12.DEC.2012 22:47:17

26 dB Bandwidth Plot on Configuration IEEE 802.11ac MCS0-Nss2 VHT40MHz / 5230 MHz / Chain 1 + Chain 2 (2TX)

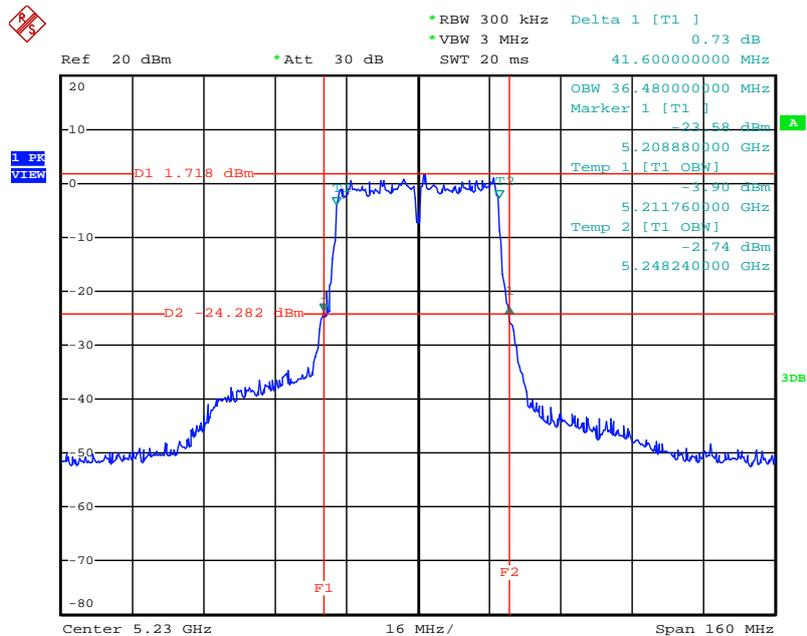

Date: 12.DEC.2012 22:47:53

26 dB Bandwidth Plot on Configuration IEEE 802.11ac MCS0-Nss1 VHT80MHz / 5210 MHz / Chain 1 (1TX)

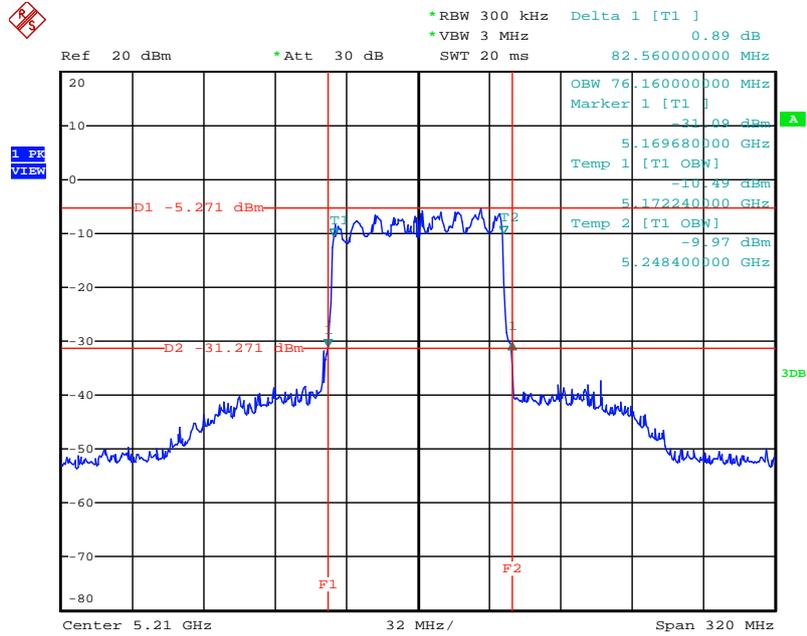

Date: 12.DEC.2012 22:45:37

26 dB Bandwidth Plot on Configuration IEEE 802.11ac MCS0-Nss2 VHT80MHz / 5210 MHz / Chain 1 + Chain 2 (2TX)

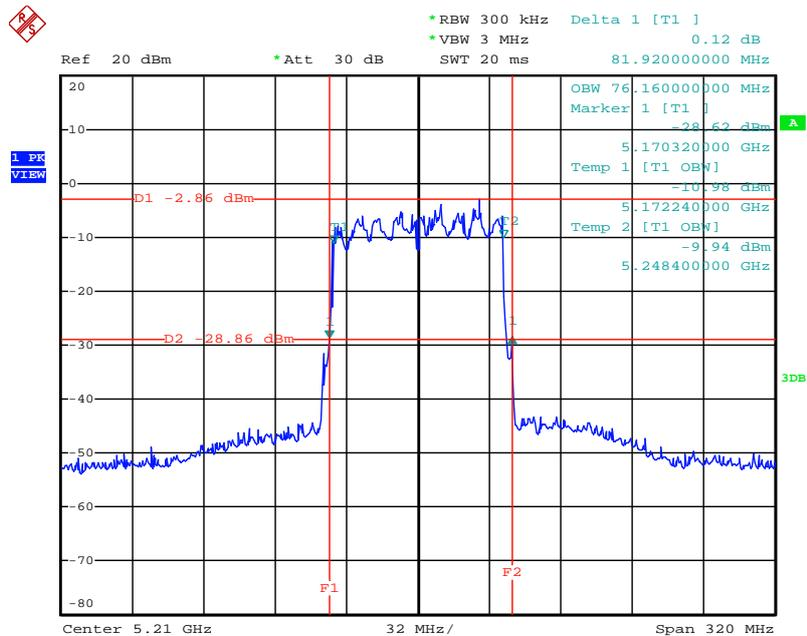

Date: 12.DEC.2012 22:46:18

26 dB Bandwidth Plot on Configuration IEEE 802.11a / 5180 MHz / Chain 1 (1TX)

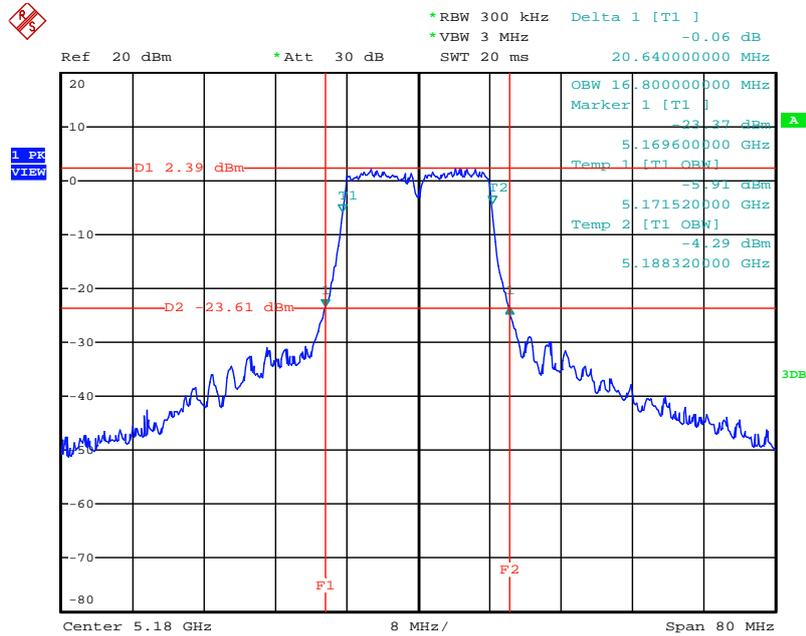

Date: 12.DEC.2012 22:37:27

26 dB Bandwidth Plot on Configuration IEEE 802.11a / 5200 MHz / Chain 1 (1TX)

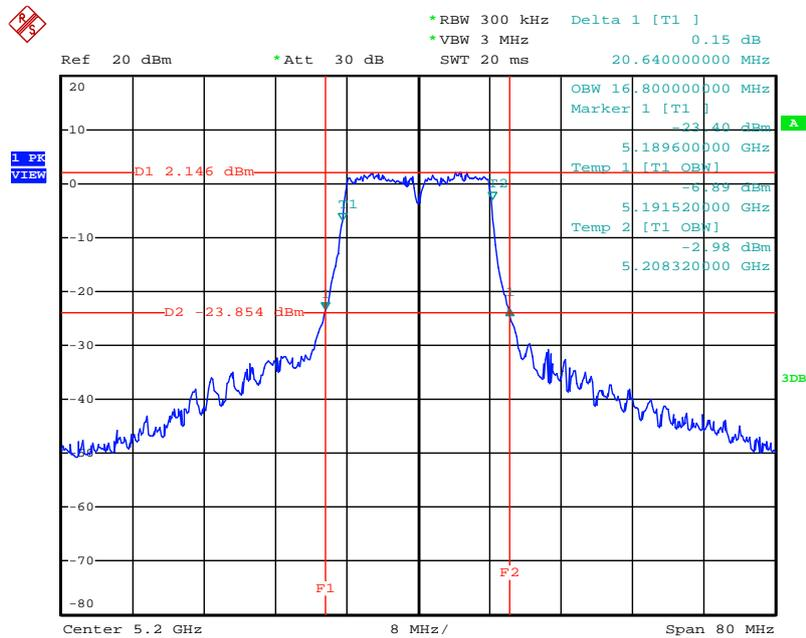

Date: 12.DEC.2012 22:38:42

26 dB Bandwidth Plot on Configuration IEEE 802.11a / 5240 MHz / Chain 1 (1TX)

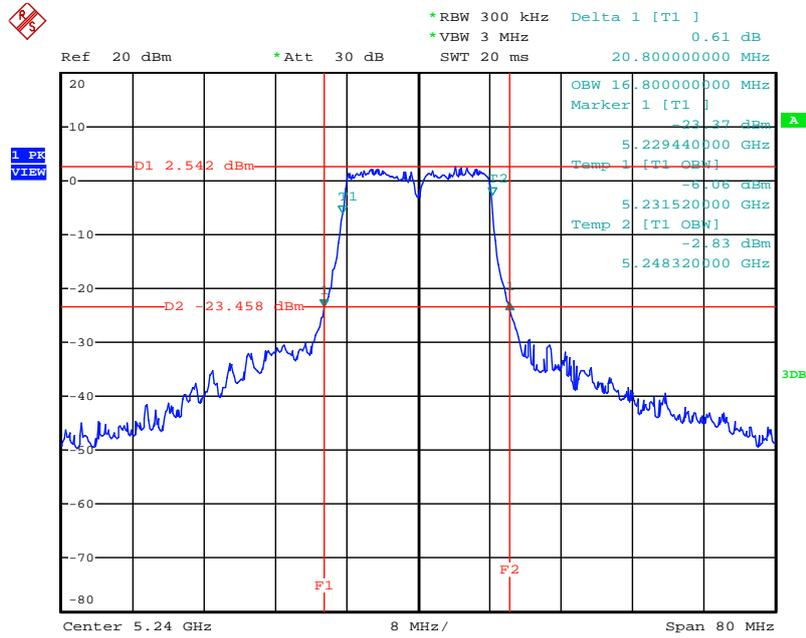

Date: 12.DEC.2012 22:39:11

4.3. Maximum Conducted Output Power Measurement

4.3.1. Limit

For the band 5.15~5.25 GHz, the maximum conducted output power over the frequency band of operation shall not exceed the lesser of 50 mW (17dBm) or $4 \text{ dBm} + 10\log B$, where B is the 26 dB emissions bandwidth in MHz. If transmitting antennas of directional gain greater than 6 dBi are used, both the maximum conducted output power and the peak power spectral density shall be reduced by the amount in dB that the directional gain of the antenna exceeds 6 dBi.

4.3.2. Measuring Instruments and Setting

Please refer to section 5 of equipments list in this report. The following table is the setting of the power meter.

Power Meter Parameter	Setting
Detector	Average

4.3.3. Test Procedures

1. The transmitter output (antenna port) was connected to the power meter.
2. Test was performed in accordance with KDB 789033 Guidelines for Compliance Testing of unlicensed National Information Infrastructure (U-NII) Devices - Part 15, Subpart E, section (C) maximum conducted output power =>(4) method PM (measurement using an RF average power meter) multiple antenna systems was performed in accordance with KDB 662911 emissions testing of transmitters with multiple outputs in the same band.
3. When measuring maximum conducted output power with multiple antenna systems, add every result of the values by mathematic formula.

4.3.4. Test Setup Layout

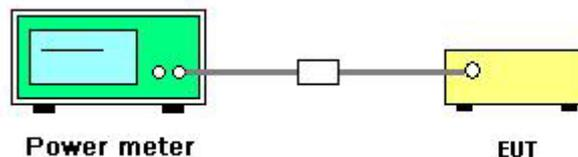

4.3.5. Test Deviation

There is no deviation with the original standard.

4.3.6. EUT Operation during Test

The EUT was programmed to be in continuously transmitting mode.

4.3.7. Test Result of Maximum Conducted Output Power

Temperature	25°C	Humidity	56%
Test Engineer	Benson Peng	Configurations	IEEE 802.11n/ac
Test Date	Dec. 12, 2012		

Configuration IEEE 802.11n MCS0 HT20MHz / Chain 1 (1TX)

Channel	Frequency	Total Conducted Output Power (dBm)	Max. Limit (dBm)	Result
36	5180 MHz	16.11	17.00	Complies
40	5200 MHz	16.15	17.00	Complies
48	5240 MHz	16.12	17.00	Complies

Configuration IEEE 802.11n MCS0 HT40MHz / Chain 1 (1TX)

Channel	Frequency	Total Conducted Output Power (dBm)	Max. Limit (dBm)	Result
38	5190 MHz	12.81	17.00	Complies
46	5230 MHz	16.85	17.00	Complies

Configuration IEEE 802.11n MCS8 HT20MHz / Chain 1 + Chain 2 (2TX)

Channel	Frequency	Conducted Power (dBm)		Total Conducted Output Power (dBm)	Max. Limit (dBm)	Result
		Chain 1	Chain 2			
36	5180 MHz	13.89	13.98	16.95	17.00	Complies
40	5200 MHz	14.03	13.65	16.85	17.00	Complies
48	5240 MHz	13.99	13.71	16.86	17.00	Complies

Configuration IEEE 802.11n MCS8 HT40MHz / Chain 1 + Chain 2 (2TX)

Channel	Frequency	Conducted Power (dBm)		Total Conducted Output Power (dBm)	Max. Limit (dBm)	Result
		Chain 1	Chain 2			
38	5190 MHz	11.99	11.26	14.65	17.00	Complies
46	5230 MHz	14.12	13.74	16.94	17.00	Complies

Configuration IEEE 802.11ac MCS0-Nss1 VHT20MHz / Chain 1 (1TX)

Channel	Frequency	Total Conducted Output Power (dBm)	Max. Limit (dBm)	Result
36	5180 MHz	16.13	17.00	Complies
40	5200 MHz	16.09	17.00	Complies
48	5240 MHz	16.17	17.00	Complies

Configuration IEEE 802.11ac MCS0-Nss1 VHT40MHz / Chain 1 (1TX)

Channel	Frequency	Total Conducted Output Power (dBm)	Max. Limit (dBm)	Result
38	5190 MHz	12.80	17.00	Complies
46	5230 MHz	16.89	17.00	Complies

Configuration IEEE 802.11ac MCS0-Nss1 VHT80MHz / Chain 1 (1TX)

Channel	Frequency	Total Conducted Output Power (dBm)	Max. Limit (dBm)	Result
42	5210 MHz	13.19	17.00	Complies

Configuration IEEE 802.11ac MCS0-Nss2 VHT20MHz / Chain 1 + Chain 2 (2TX)

Channel	Frequency	Conducted Power (dBm)		Total Conducted Output Power (dBm)	Max. Limit (dBm)	Result
		Chain 1	Chain 2			
36	5180 MHz	13.87	13.71	16.80	17.00	Complies
40	5200 MHz	13.79	13.68	16.75	17.00	Complies
48	5240 MHz	13.98	13.72	16.86	17.00	Complies

Configuration IEEE 802.11ac MCS0-Nss2 VHT40MHz / Chain 1 + Chain 2 (2TX)

Channel	Frequency	Conducted Power (dBm)		Total Conducted Output Power (dBm)	Max. Limit (dBm)	Result
		Chain 1	Chain 2			
38	5190 MHz	11.46	10.70	14.11	17.00	Complies
46	5230 MHz	14.05	13.81	16.94	17.00	Complies

Configuration IEEE 802.11ac MCS0-Nss2 VHT80MHz / Chain 1 + Chain 2 (2TX)

Channel	Frequency	Conducted Power (dBm)		Total Conducted Output Power (dBm)	Max. Limit (dBm)	Result
		Chain 1	Chain 2			
42	5210 MHz	10.65	10.72	13.70	17.00	Complies

Temperature	25°C	Humidity	56%
Test Engineer	Benson Peng	Configurations	IEEE 802.11a
Test Date	Dec. 12, 2012		

Configuration IEEE 802.11a / Chain 1 (1TX)

Channel	Frequency	Total Conducted Output Power (dBm)	Max. Limit (dBm)	Result
36	5180 MHz	16.15	17.00	Complies
40	5200 MHz	16.21	17.00	Complies
48	5240 MHz	16.19	17.00	Complies

4.4. Power Spectral Density Measurement

4.4.1. Limit

The power spectral density is defined as the highest level of power in dBm per MHz generated by the transmitter within the power envelope. The following table is power spectral density limits and decrease power density limit rule refer to section 4.3.1.

Frequency Range	Power Spectral Density limit (dBm/MHz)
5.15–5.25 GHz	4

4.4.2. Measuring Instruments and Setting

Please refer to section 5 of equipments list in this report. The following table is the setting of the spectrum analyzer.

Spectrum Parameter	Setting
Attenuation	Auto
Span Frequency	Encompass the entire emissions bandwidth (EBW) of the signal
RB	1000 kHz
VB	3000 kHz
Detector	RMS
Trace	AVERAGE
Sweep Time	Auto
Trace Average	100 times

4.4.3. Test Procedures

1. The transmitter output (antenna port) was connected RF switch to the spectrum analyzer.
2. Test was performed in accordance with KDB 789033 Guidelines for Compliance Testing of Unlicensed National Information Infrastructure (U-NII) Devices - Part 15, Subpart E, section (C) Maximum conducted output power => (d) Method SA-2 (trace averaging across on and off times of the EUT transmissions, followed by duty cycle correction).
3. Multiple antenna systems was performed in accordance with KDB 662911 in-Band Power Spectral Density (PSD) Measurements (1) Measure and sum the spectra across the outputs.
4. When measuring first spectral bin of output 1 is summed with that in the first spectral bin of output 2 and that from the first spectral bin of output 3 and so on up to the Nth output to obtain the value for the first frequency bin of the summed spectrum. The summed spectrum value for each of the other frequency bins is computed in the same way.

4.4.4. Test Setup Layout

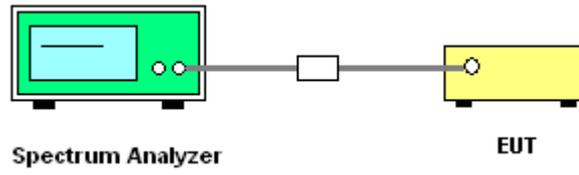

4.4.5. Test Deviation

There is no deviation with the original standard.

4.4.6. EUT Operation during Test

The EUT was programmed to be in continuously transmitting mode.

4.4.7. Test Result of Power Spectral Density

Temperature	25°C	Humidity	56%
Test Engineer	Benson Peng	Configurations	IEEE 802.11n / ac
Test Date	Dec. 12, 2012		

Configuration IEEE 802.11n MCS0 HT20MHz / Chain 1 (1TX)

Channel	Frequency	Total Power Density (dBm/MHz)	Max. Limit (dBm/MHz)	Result
36	5180 MHz	3.79	4.00	Complies
40	5200 MHz	3.87	4.00	Complies
48	5240 MHz	3.99	4.00	Complies

Configuration IEEE 802.11n MCS0 HT40MHz / Chain 1 (1TX)

Channel	Frequency	Total Power Density (dBm/MHz)	Max. Limit (dBm/MHz)	Result
38	5190 MHz	-1.89	4.00	Complies
46	5230 MHz	2.52	4.00	Complies

Configuration IEEE 802.11n MCS8 HT20MHz / Chain 1 + Chain 2 (2TX)

Channel	Frequency	Total Power Density (dBm/MHz)	Max. Limit (dBm/MHz)	Result
36	5180 MHz	3.69	4.00	Complies
40	5200 MHz	3.69	4.00	Complies
48	5240 MHz	3.70	4.00	Complies

Configuration IEEE 802.11n MCS8 HT40MHz / Chain 1 + Chain 2 (2TX)

Channel	Frequency	Total Power Density (dBm/MHz)	Max. Limit (dBm/MHz)	Result
38	5190 MHz	-0.94	4.00	Complies
46	5230 MHz	0.60	4.00	Complies

Configuration IEEE 802.11ac MCS0-Nss1 VHT20MHz / Chain 1 (1TX)

Channel	Frequency	Total Power Density (dBm/MHz)	Max. Limit (dBm/MHz)	Result
36	5180 MHz	3.89	4.00	Complies
40	5200 MHz	3.89	4.00	Complies
48	5240 MHz	3.80	4.00	Complies

Configuration IEEE 802.11ac MCS0-Nss1 VHT40MHz / Chain 1 (1TX)

Channel	Frequency	Total Power Density (dBm/MHz)	Max. Limit (dBm/MHz)	Result
38	5190 MHz	-2.10	4.00	Complies
46	5230 MHz	2.45	4.00	Complies

Configuration IEEE 802.11ac MCS0-Nss1 VHT 80MHz / Chain 1 (1TX)

Channel	Frequency	Total Power Density (dBm/MHz)	Max. Limit (dBm/MHz)	Result
42	5210 MHz	-3.50	4.00	Complies

Configuration IEEE 802.11ac MCS0-Nss2 VHT20MHz / Chain 1 + Chain 2 (2TX)

Channel	Frequency	Total Power Density (dBm/MHz)	Max. Limit (dBm/MHz)	Result
36	5180 MHz	3.44	4.00	Complies
40	5200 MHz	3.37	4.00	Complies
48	5240 MHz	3.49	4.00	Complies

Configuration IEEE 802.11ac MCS0-Nss2 VHT40MHz / Chain 1 + Chain 2 (2TX)

Channel	Frequency	Total Power Density (dBm/MHz)	Max. Limit (dBm/MHz)	Result
38	5190 MHz	-1.70	4.00	Complies
46	5230 MHz	0.88	4.00	Complies

Configuration IEEE 802.11ac MCS0-Nss2 VHT 80MHz / Chain 1 + Chain 2 (2TX)

Channel	Frequency	Total Power Density (dBm/MHz)	Max. Limit (dBm/MHz)	Result
42	5210 MHz	-4.23	4.00	Complies

Temperature	25°C	Humidity	56%
Test Engineer	Benson Peng	Configurations	IEEE 802.11a
Test Date	Dec. 12, 2012		

Configuration IEEE 802.11a / Chain 1 (1TX)

Channel	Frequency	Total Power Density (dBm/MHz)	Max. Limit (dBm/MHz)	Result
36	5180 MHz	3.86	4.00	Complies
40	5200 MHz	3.88	4.00	Complies
48	5240 MHz	3.84	4.00	Complies

Note: All the test values were listed in the report.

For plots, only the channel with maximum results was shown.

Power Density Plot on Configuration IEEE 802.11n MCS0 HT20MHz / 5240 MHz / Chain 1 (1TX)

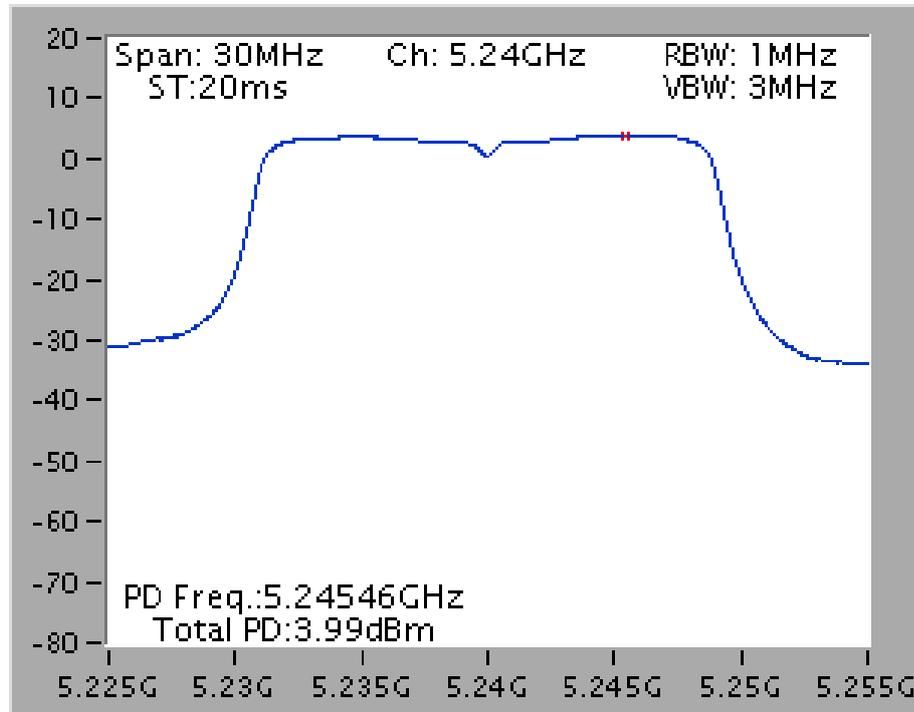

Power Density Plot on Configuration IEEE 802.11n MCS0 HT40MHz / 5230 MHz / Chain 1 (1TX)

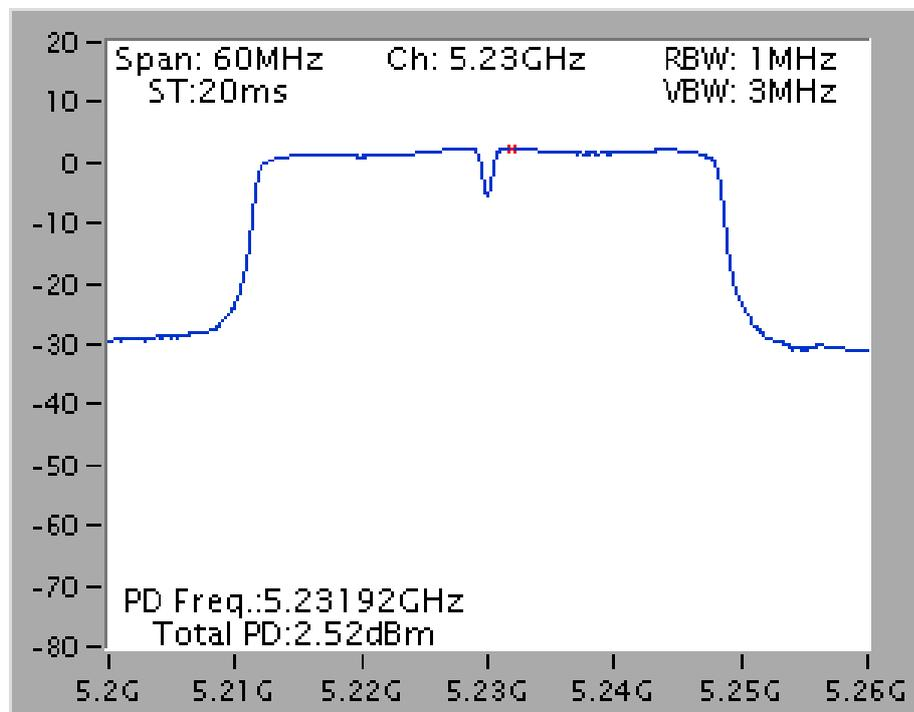

Power Density Plot on Configuration IEEE 802.11n MCS8 HT20MHz / 5240 MHz /
Chain 1 + Chain 2 (2TX)

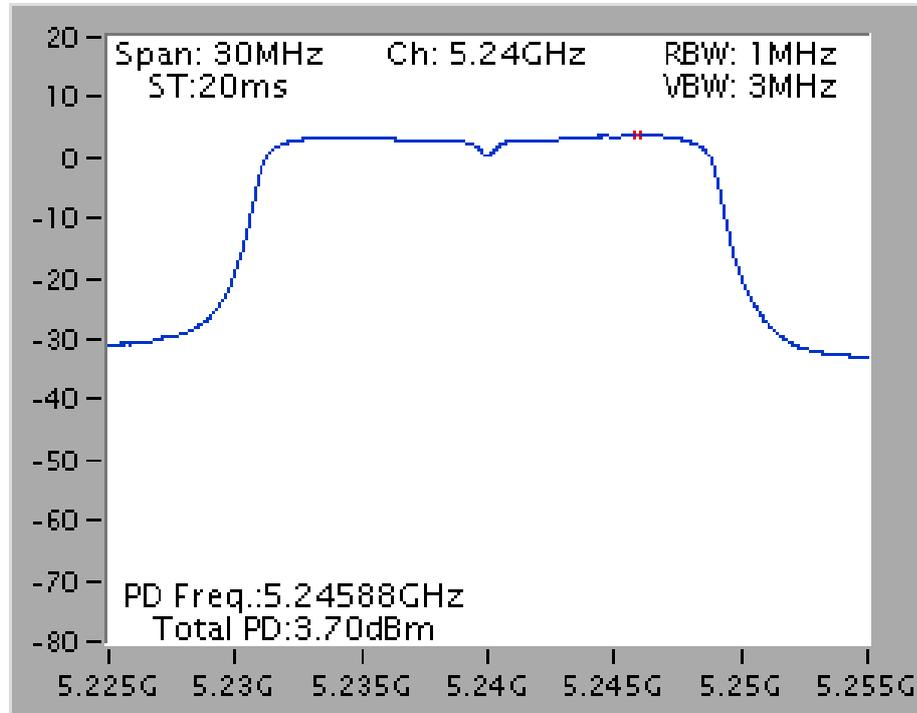

Power Density Plot on Configuration IEEE 802.11n MCS8 HT40MHz / 5230 MHz /
Chain 1 + Chain 2 (2TX)

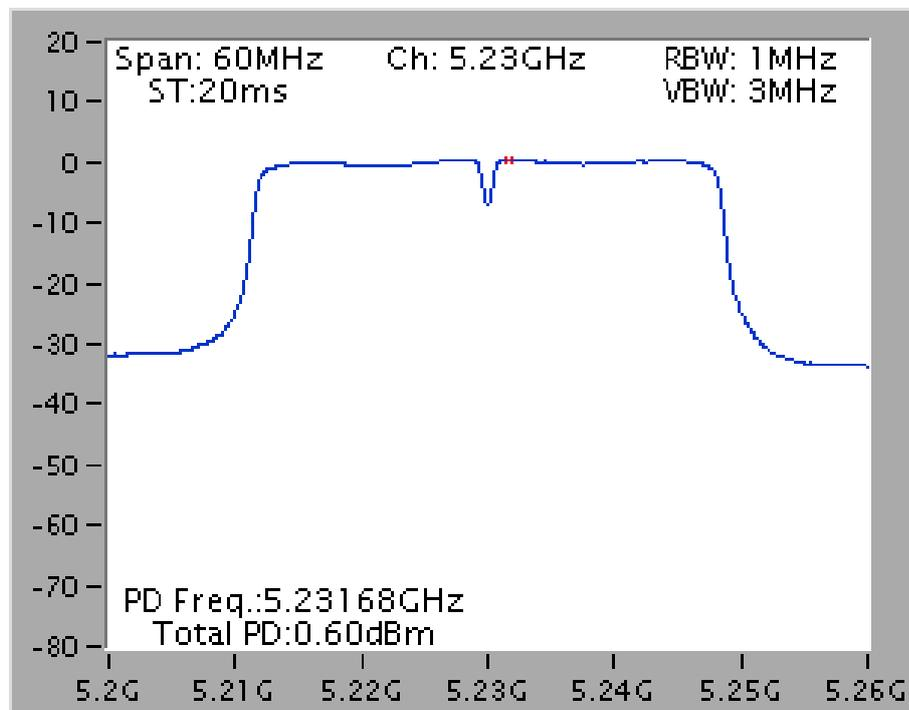

Power Density Plot on Configuration IEEE 802.11ac MCS0-Nss1 VHT20MHz / 5200 MHz / Chain 1 (1TX)

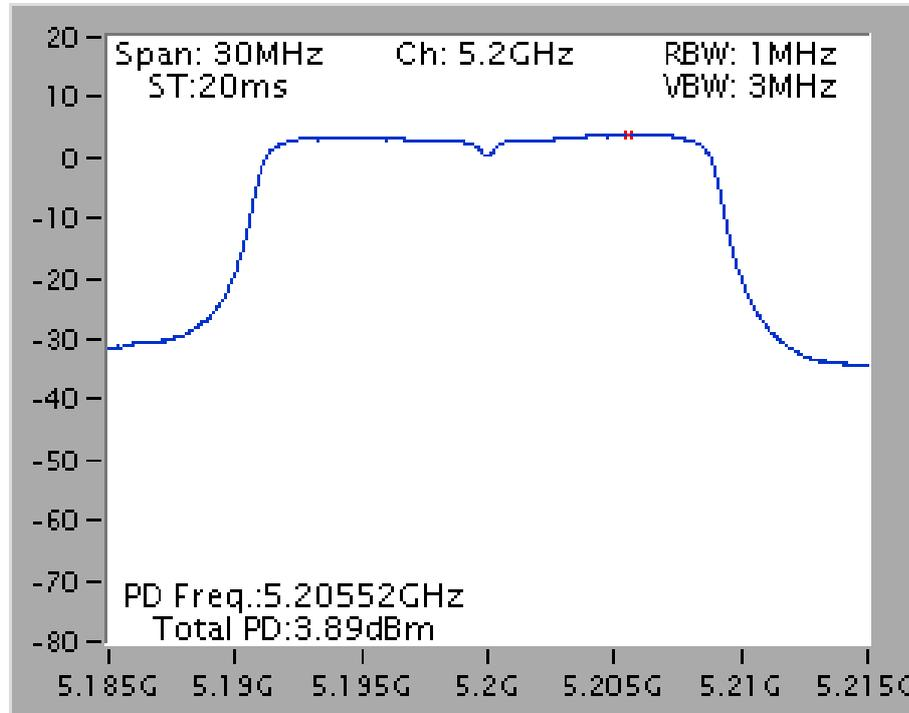

Power Density Plot on Configuration IEEE 802.11ac MCS0-Nss1 VHT40MHz / 5230 MHz / Chain 1 (1TX)

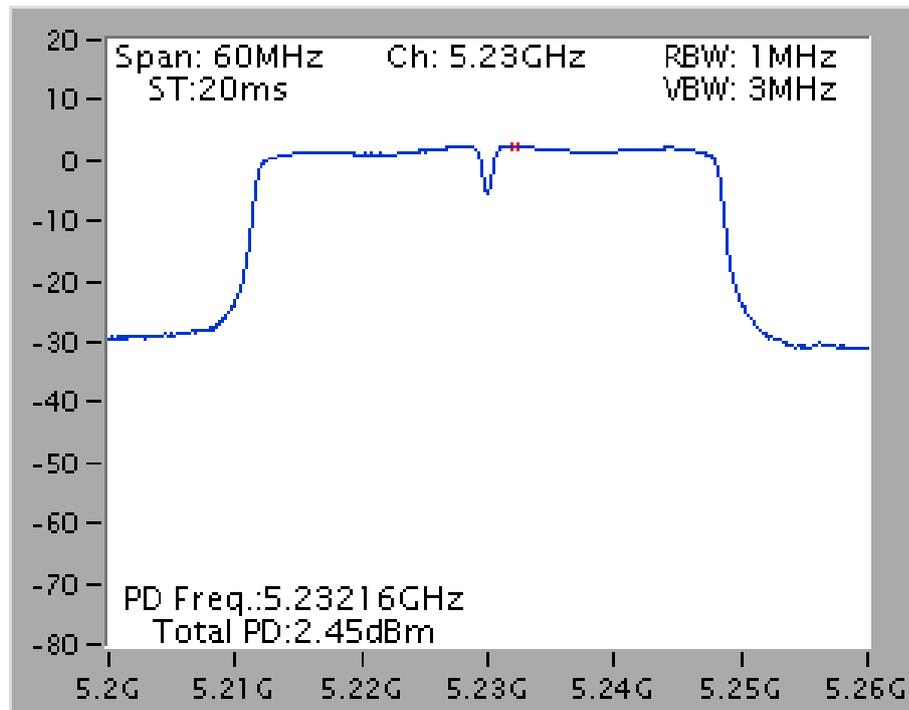

Power Density Plot on Configuration IEEE 802.11ac MCS0-Nss2 VHT20MHz / 5240 MHz / Chain 1 + Chain 2 (2TX)

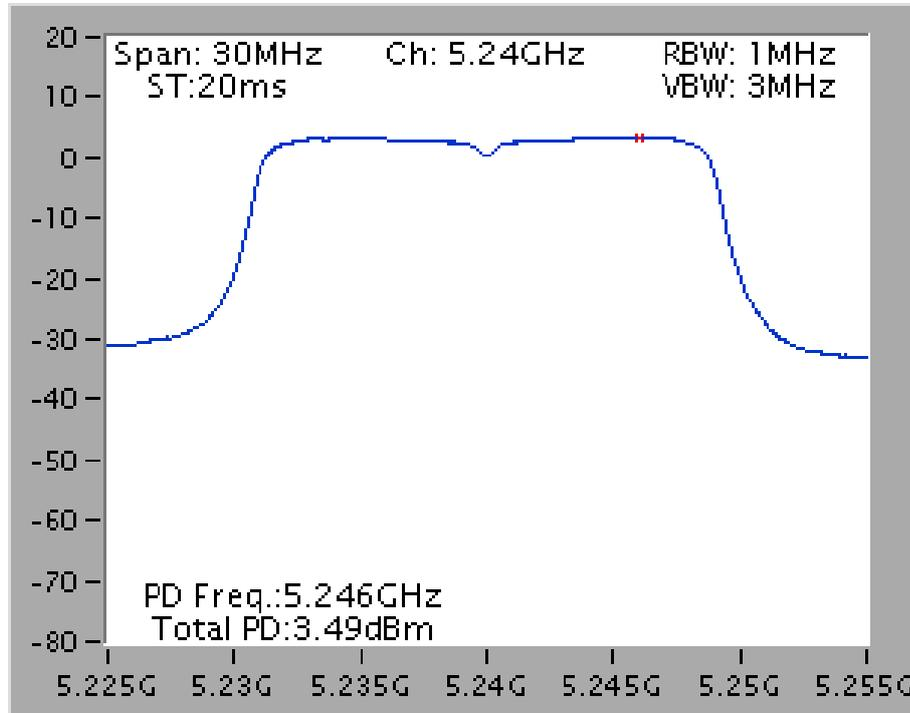

Power Density Plot on Configuration IEEE 802.11ac MCS0-Nss2 VHT40MHz / 5230 MHz / Chain 1 + Chain 2 (2TX)

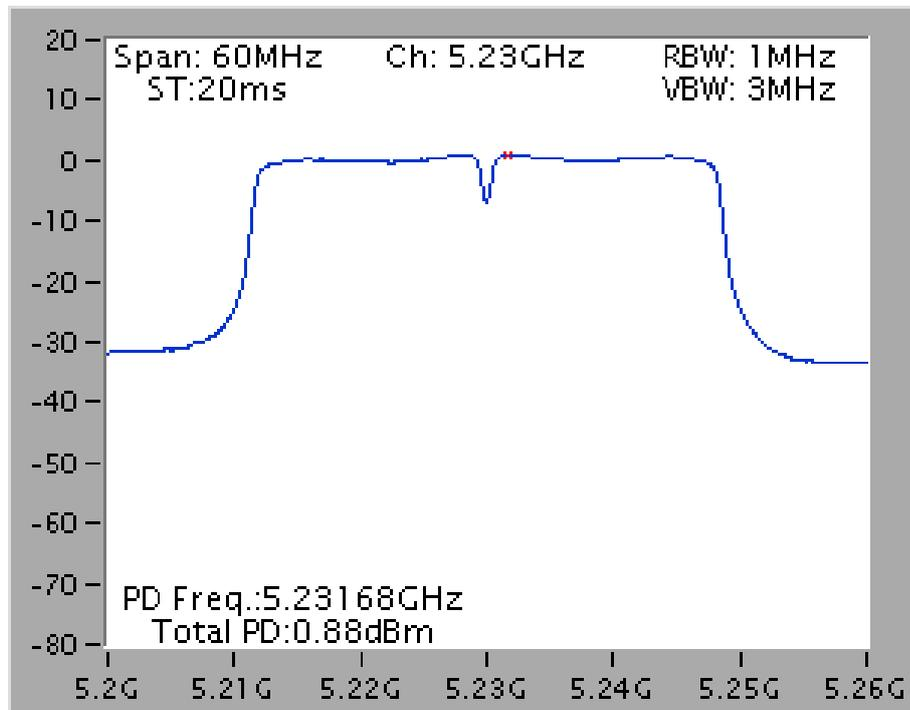

Power Density Plot on Configuration IEEE 802.11ac MCS0-Nss1 VHT 80MHz / 5210 MHz /
Chain 1 (1TX)

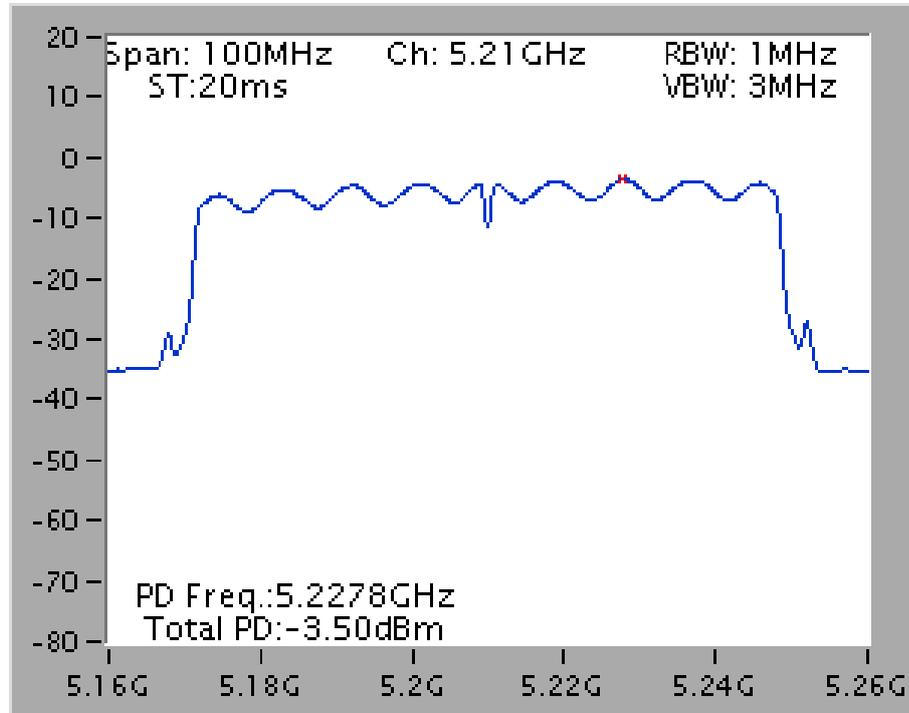

Power Density Plot on Configuration IEEE 802.11ac MCS0-Nss2 VHT 80MHz / 5210 MHz /
Chain 1 + Chain 2 (2TX)

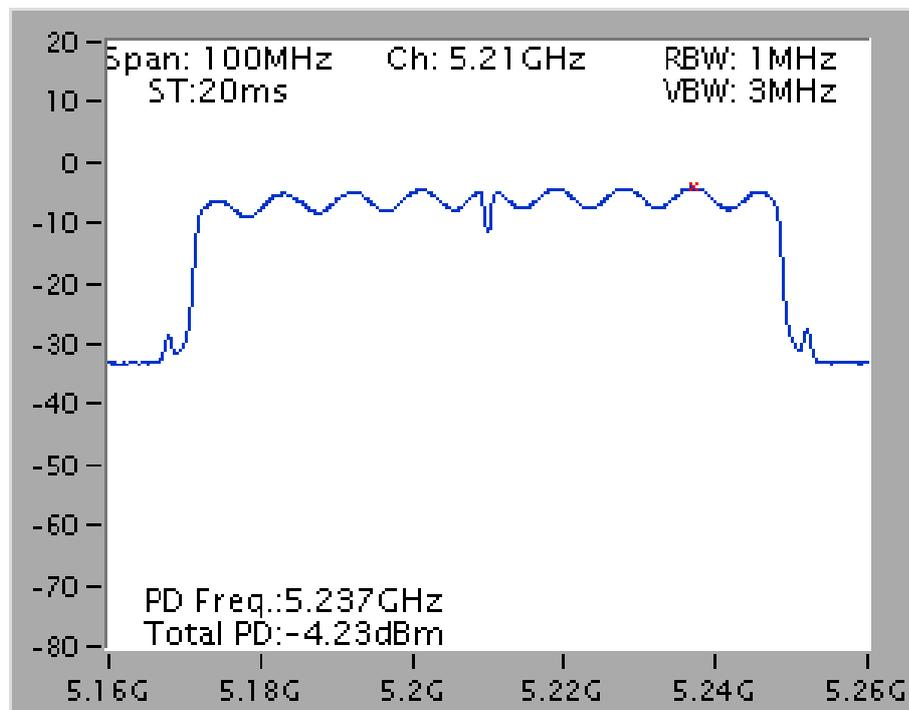

Power Density Plot on Configuration IEEE 802.11a / 5200 MHz / Chain 1 (1TX)

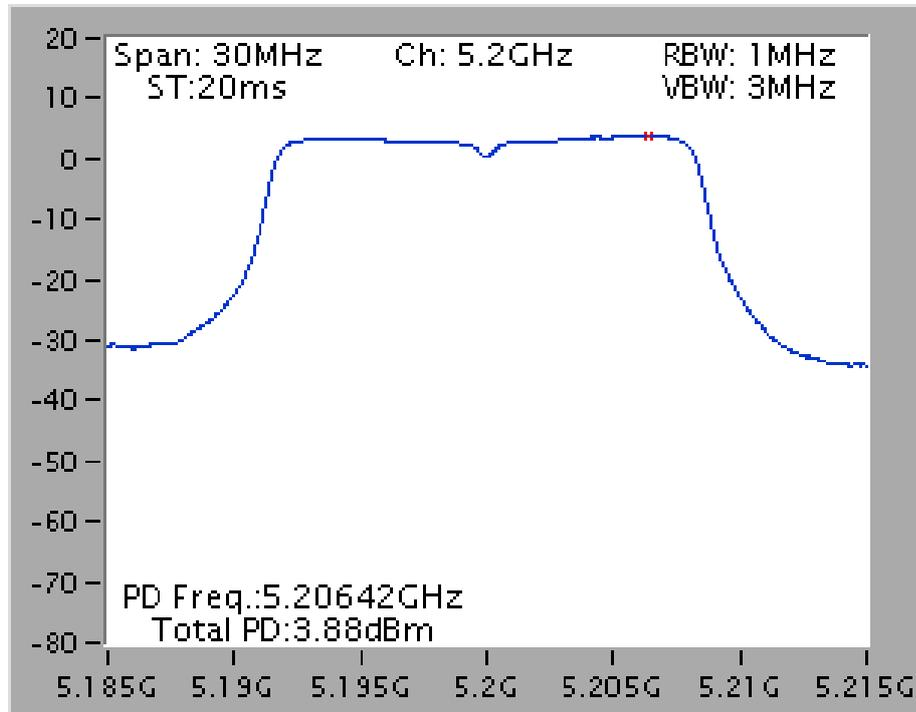

4.5. Peak Excursion Measurement

4.5.1. Limit

The ratio of the peak excursion of the modulation envelope (measured using a peak hold function) to the maximum conducted output power (measured as specified above) shall not exceed 13 dB across any 1 MHz bandwidth or the emissions bandwidth whichever is less.

4.5.2. Measuring Instruments and Setting

Please refer to section 5 of equipments list in this report. The following table is the setting of the spectrum analyzer.

Spectrum Parameter	Setting
Attenuation	Auto
Span Frequency	Encompass the entire emissions bandwidth (EBW) of the signal
RB	1000 kHz (Peak Trace) / 1000 kHz (Average Trace)
VB	3000 kHz (Peak Trace) / 3000 kHz (Average Trace)
Detector	Peak (Peak Trace) / RMS (Average Trace)
Trace	Peak : Trace :Max hold/Average: Trace Average Sweep Count 100
Sweep Time	AUTO

4.5.3. Test Procedures

1. The test procedure is the same as section 4.6.3.
2. Trace A, Set RBW =1MHz, VBW = 3MHz, Span >26dB bandwidth, Max. hold.
3. Delta Mark trace A Maximum frequency and trace B same frequency.
4. Repeat the above procedure until measurements for all frequencies were complete.

4.5.4. Test Setup Layout

This test setup layout is the same as that shown in section 4.6.4.

4.5.5. Test Deviation

There is no deviation with the original standard.

4.5.6. EUT Operation during Test

The EUT was programmed to be in continuously transmitting mode.

4.5.7. Test Result of Peak Excursion

Temperature	25°C	Humidity	56%
Test Engineer	Benson Peng	Configurations	IEEE 802.11n / ac
Test Date	Dec. 12, 2012		

Configuration IEEE 802.11n MCS0 HT20MHz / Chain 1 (1TX)

Channel	Frequency	Peak Excursion (dB)	Max. Limit (dB)	Result
40	5200 MHz	8.95	13	Complies

Configuration IEEE 802.11n MCS0 HT40MHz / Chain 1 (1TX)

Channel	Frequency	Peak Excursion (dB)	Max. Limit (dB)	Result
46	5230 MHz	8.02	13	Complies

Configuration IEEE 802.11n MCS8 HT20MHz / Chain 1 + Chain 2 (2TX)

Channel	Frequency	Peak Excursion (dB)	Max. Limit (dB)	Result
36	5180 MHz	9.53	13	Complies

Configuration IEEE 802.11n MCS8 HT40MHz / Chain 1 + Chain 2 (2TX)

Channel	Frequency	Peak Excursion (dB)	Max. Limit (dB)	Result
46	5230 MHz	9.69	13	Complies

Configuration IEEE 802.11ac MCS0-Nss1 VHT80MHz / Chain 1 (1TX)

Channel	Frequency	Peak Excursion (dB)	Max. Limit (dB)	Result
42	5210 MHz	8.63	13	Complies

Configuration IEEE 802.11ac MCS0-Nss2 VHT80MHz / Chain 1 + Chain 2 (2TX)

Channel	Frequency	Peak Excursion (dB)	Max. Limit (dB)	Result
42	5210 MHz	9.25	13	Complies

Temperature	25°C	Humidity	56%
Test Engineer	Benson Peng	Configurations	IEEE 802.11a
Test Date	Dec. 12, 2012		

Configuration IEEE 802.11a / Chain 1 (1TX)

Channel	Frequency	Peak Excursion (dB)	Max. Limit (dB)	Result
40	5200 MHz	8.43	13	Complies

Note: All the test values were listed in the report.

For plots, only the channel with maximum results was shown.

Peak Excursion Plot on Configuration IEEE 802.11n MCS0 HT20MHz / 5200MHz / Chain 1 (1TX)

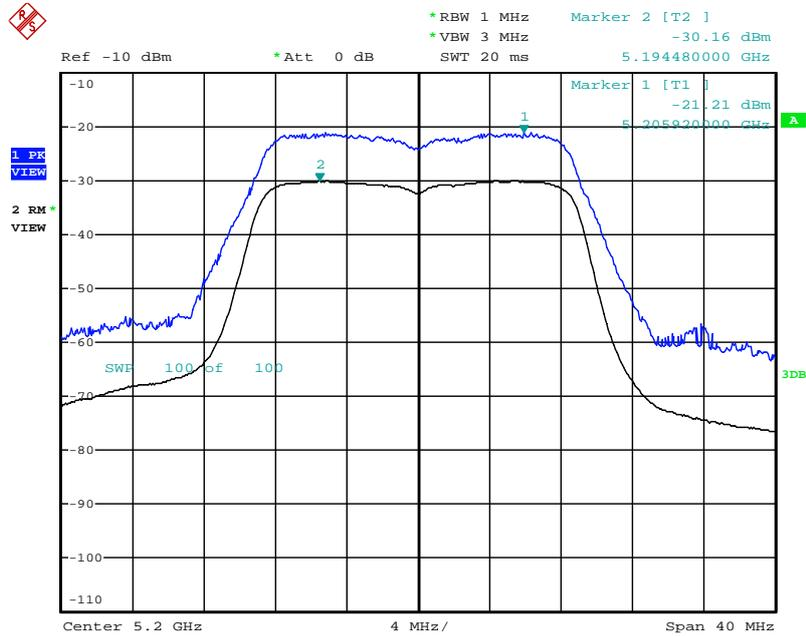

Date: 12.DEC.2012 23:06:13

Peak Excursion Plot on Configuration IEEE 802.11n MCS0 HT40MHz / 5230MHz / Chain 1 (1TX)

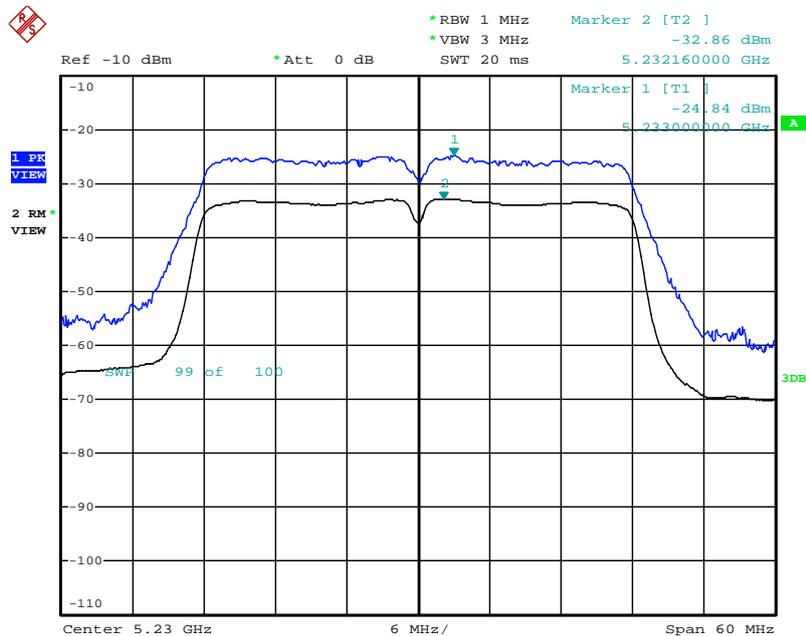

Date: 12.DEC.2012 23:06:56

Peak Excursion Plot on Configuration IEEE 802.11n MCS8 HT20MHz / 5180MHz / Chain 1 + Chain 2 (2TX)

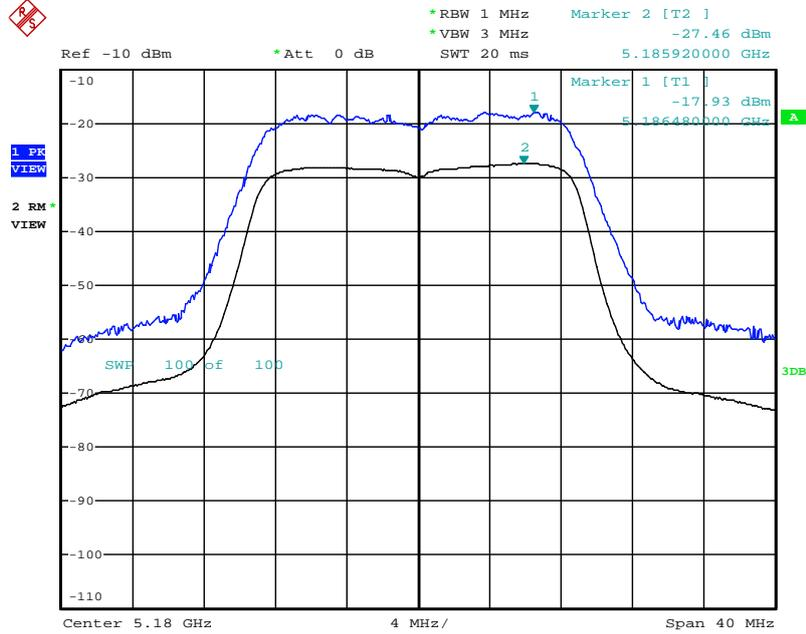

Date: 12.DEC.2012 23:10:37

Peak Excursion Plot on Configuration IEEE 802.11n MCS8 HT40MHz / 5230MHz / Chain 1 + Chain 2 (2TX)

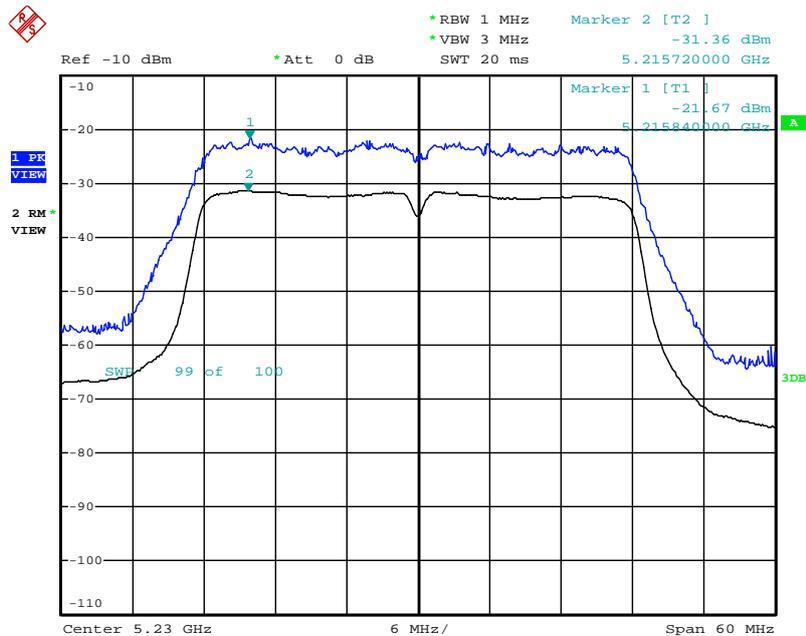

Date: 12.DEC.2012 23:09:35

Peak Excursion Plot on Configuration IEEE 802.11ac MCS0-Nss1 VHT 80MHz / 5210MHz / Chain 1 (1TX)

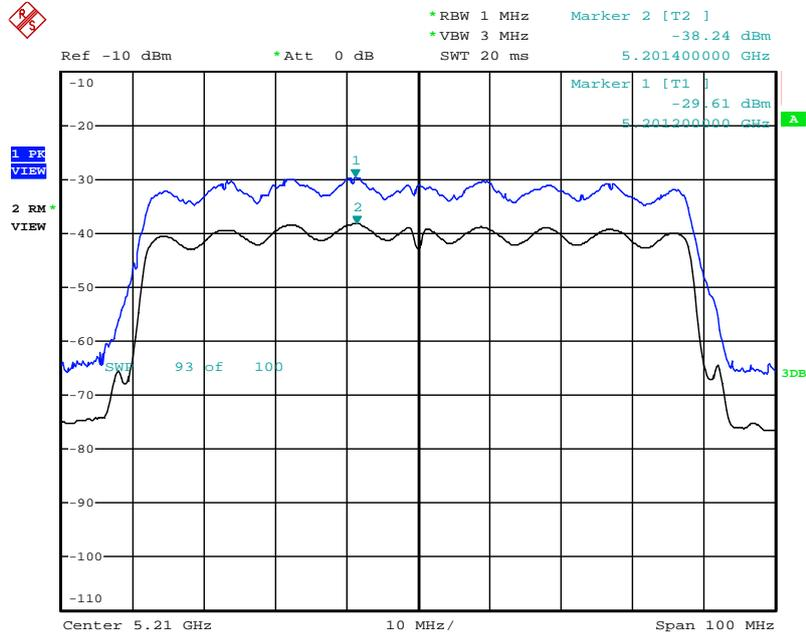

Date: 12.DEC.2012 23:07:46

Peak Excursion Plot on Configuration IEEE 802.11ac MCS0-Nss2 VHT 80MHz / 5210MHz / Chain 1 + Chain 2 (2TX)

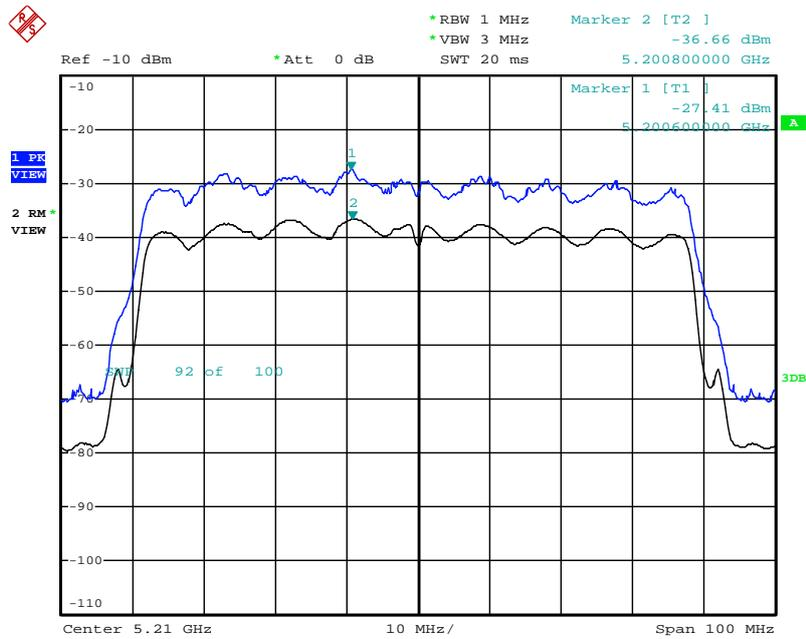

Date: 12.DEC.2012 23:08:36

Peak Excursion Plot on Configuration IEEE 802.11a / 5200MHz / Chain 1 (1TX)

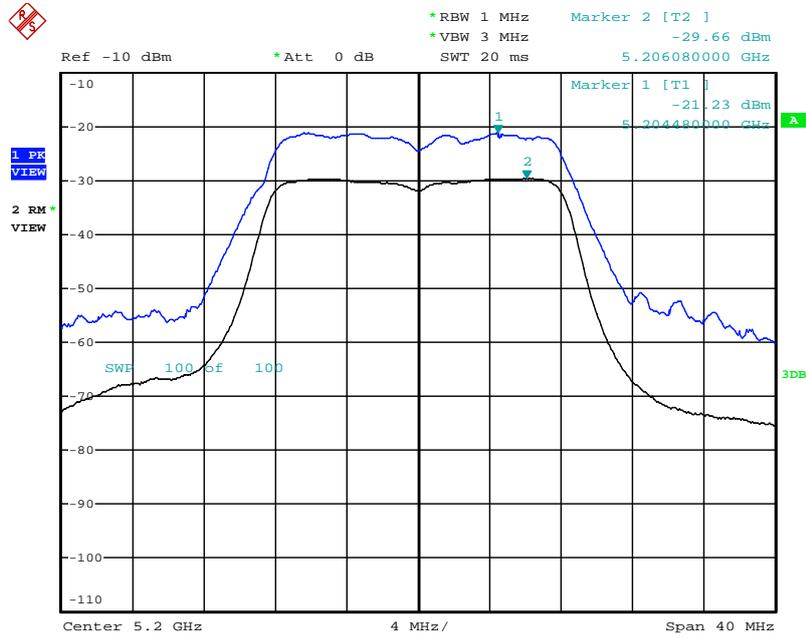

Date: 12.DEC.2012 23:05:24

4.6. Radiated Emissions Measurement

4.6.1. Limit

For transmitters operating in the 5.15-5.35 GHz band: all emissions outside of the 5.15-5.35 GHz band shall not exceed an EIRP of -27 dBm/MHz (68.3dBuV/m at 3m). For transmitters operating in the In addition, In case the emission fall within the restricted band specified on 15.205(a), then the 15.209(a) limit in the table below has to be followed.

Frequencies (MHz)	Field Strength (micorvolts/meter)	Measurement Distance (meters)
0.009~0.490	2400/F(KHz)	300
0.490~1.705	24000/F(KHz)	30
1.705~30.0	30	30
30~88	100	3
88~216	150	3
216~960	200	3
Above 960	500	3

4.6.2. Measuring Instruments and Setting

Please refer to section 5 of equipments list in this report. The following table is the setting of spectrum analyzer and receiver.

Spectrum Parameter	Setting
Attenuation	Auto
Start Frequency	1000 MHz
Stop Frequency	40 GHz
RB / VB (Emission in restricted band)	1MHz / 3MHz for Peak, 1 MHz / 10Hz for Average
RB / VB (Emission in non-restricted band)	1MHz / 3MHz for peak

Receiver Parameter	Setting
Attenuation	Auto
Start ~ Stop Frequency	9kHz~150kHz / RB 200Hz for QP
Start ~ Stop Frequency	150kHz~30MHz / RB 9kHz for QP
Start ~ Stop Frequency	30MHz~1000MHz / RB 120kHz for QP

4.6.3. Test Procedures

1. Configure the EUT according to ANSI C63.10. The EUT was placed on the top of the turntable 0.8 meter above ground. The phase center of the receiving antenna mounted on the top of a height-variable antenna tower was placed 3 meters far away from the turntable.
2. Power on the EUT and all the supporting units. The turntable was rotated by 360 degrees to determine the position of the highest radiation.
3. The height of the broadband receiving antenna was varied between one meter and four meters above ground to find the maximum emissions field strength of both horizontal and vertical polarization.
4. For each suspected emissions, the antenna tower was scan (from 1 M to 4 M) and then the turntable was rotated (from 0 degree to 360 degrees) to find the maximum reading.
5. Set the test-receiver system to Peak or CISPR quasi-peak Detect Function with specified bandwidth under Maximum Hold Mode.
6. For emissions above 1GHz, use 1MHz VBW and RBW for peak reading. Then 1MHz RBW and 10Hz VBW for average reading in spectrum analyzer.
7. When the radiated emissions limits are expressed in terms of the average value of the emissions, and pulsed operation is employed, the measurement field strength shall be determined by averaging over one complete pulse train, including blanking intervals, as long as the pulse train does not exceed 0.1 seconds. As an alternative (provided the transmitter operates for longer than 0.1 seconds) or in cases where the pulse train exceeds 0.1 seconds, the measured field strength shall be determined from the average absolute voltage during a 0.1 second interval during which the field strength is at its maximum value.
8. If the emissions level of the EUT in peak mode was 3 dB lower than the average limit specified, then testing will be stopped and peak values of EUT will be reported, otherwise, the emissions which do not have 3 dB margin will be repeated one by one using the quasi-peak method for below 1GHz.
9. For testing above 1GHz, the emissions level of the EUT in peak mode was lower than average limit (that means the emissions level in peak mode also complies with the limit in average mode), then testing will be stopped and peak values of EUT will be reported, otherwise, the emissions will be measured in average mode again and reported.
10. In case the emission is lower than 30MHz, loop antenna has to be used for measurement and the recorded data should be QP measured by receiver. High – Low scan is not required in this case.

4.6.4. Test Setup Layout

For radiated emissions below 1 GHz

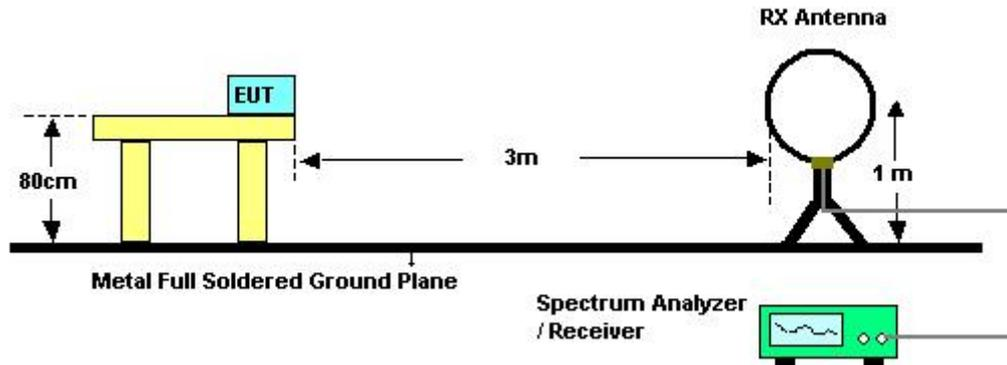

For radiated emissions above 1 GHz

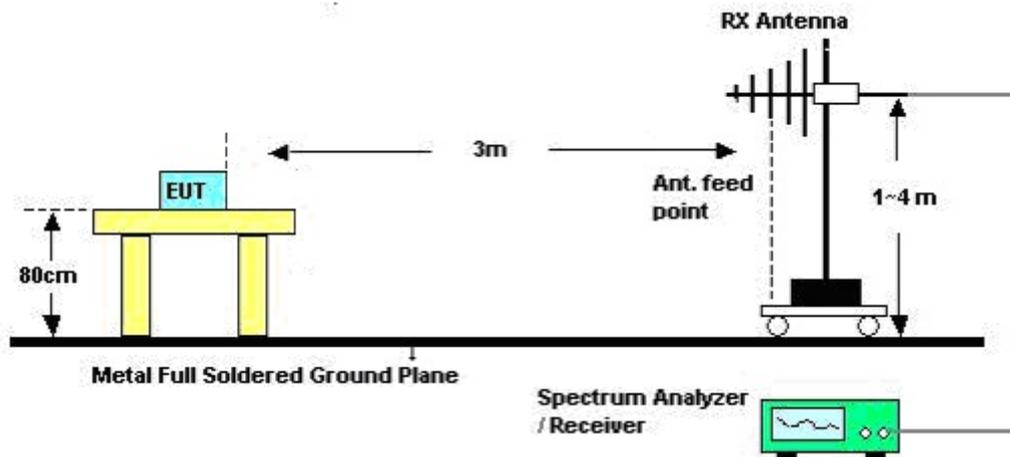

4.6.5. Test Deviation

There is no deviation with the original standard.

4.6.6. EUT Operation during Test

The EUT was programmed to be in continuously transmitting mode.

4.6.7. Results of Radiated Emissions (9kHz~30MHz)

Temperature	24.5°C	Humidity	57%
Test Engineer	Magic Lai	Configurations	Normal Link
Test Date	Dec. 05, 2012		

Freq. (MHz)	Level (dBuV)	Over Limit (dB)	Limit Line (dBuV)	Remark
-	-	-	-	See Note

Note:

The amplitude of spurious emissions that are attenuated by more than 20dB below the permissible value has no need to be reported.

Distance extrapolation factor = $40 \log (\text{specific distance} / \text{test distance})$ (dB);

Limit line = specific limits (dBuV) + distance extrapolation factor.

4.6.8. Results of Radiated Emissions (30MHz~1GHz)

Temperature	24.5°C	Humidity	57%
Test Engineer	Magic Lai	Configurations	Normal Link

Horizontal

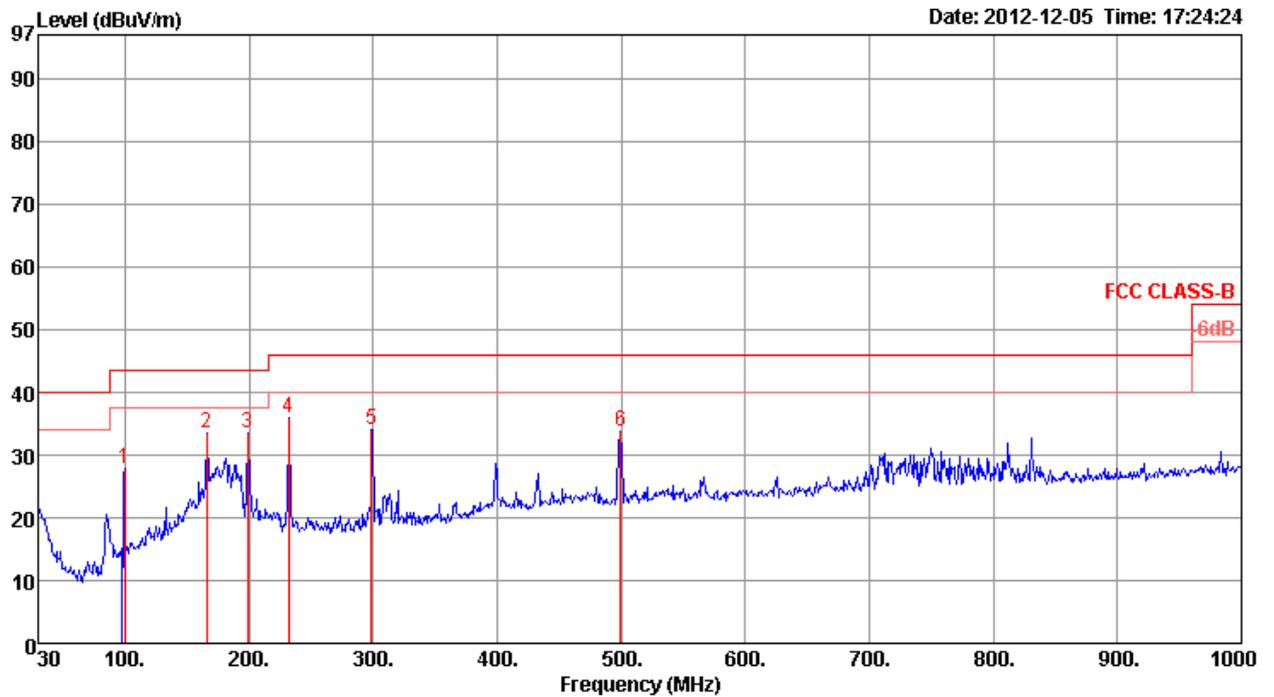

	Freq	Level	Limit	Over	Read	CableAntenna	Preamp	Remark	A/Pos	T/Pos	Pol/Phase
	MHz	dBuV/m	dBuV/m	dB	dBuV	dB	dB/m	dB	cm	deg	
1	99.84	27.73	43.50	-15.77	43.14	1.20	10.99	27.60 Peak	400	0	HORIZONTAL
2	165.80	33.61	43.50	-9.89	46.88	1.53	12.47	27.27 Peak	400	0	HORIZONTAL
3	198.78	33.56	43.50	-9.94	49.73	1.69	9.25	27.11 Peak	400	0	HORIZONTAL
4	231.76	35.95	46.00	-10.05	49.75	1.83	11.41	27.04 Peak	400	0	HORIZONTAL
5	298.69	34.08	46.00	-11.92	45.53	2.10	13.35	26.90 Peak	400	0	HORIZONTAL
6	499.48	33.78	46.00	-12.22	41.56	2.70	17.61	28.09 Peak	400	0	HORIZONTAL

Vertical

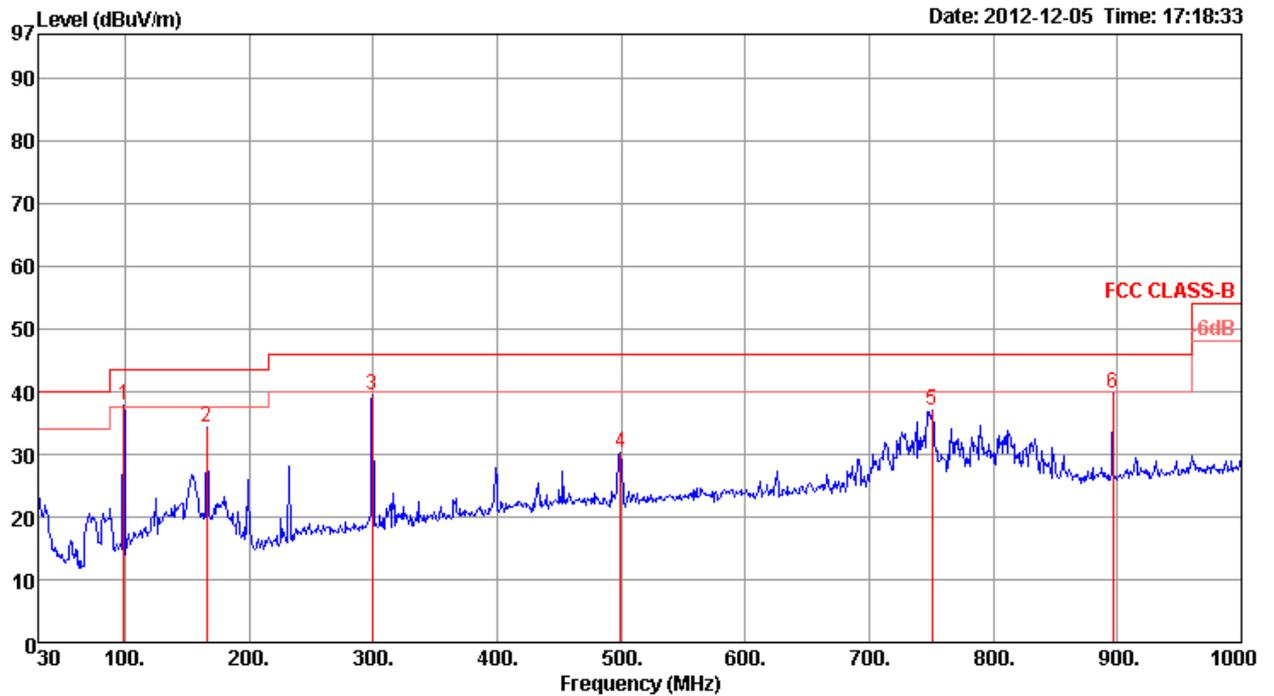

	Freq	Level	Limit	Over	Read	CableAntenna	Preamp	Remark	A/Pos	T/Pos	Pol/Phase
	MHz	dBuV/m	dBuV/m	dB	dBuV	dB	dB/m	dB	cm	deg	
1	98.87	37.75	43.50	-5.75	53.39	1.18	10.79	27.61 Peak	400	0	VERTICAL
2	165.80	34.44	43.50	-9.06	47.71	1.53	12.47	27.27 Peak	400	0	VERTICAL
3	299.66	39.46	46.00	-6.54	50.90	2.10	13.36	26.90 Peak	400	0	VERTICAL
4	499.48	30.34	46.00	-15.66	38.12	2.70	17.61	28.09 Peak	400	0	VERTICAL
5	750.71	36.88	46.00	-9.12	41.75	3.50	19.43	27.80 Peak	400	0	VERTICAL
6	896.21	39.59	46.00	-6.41	42.92	3.58	20.50	27.41 Peak	400	0	VERTICAL

Note:

The amplitude of spurious emissions that are attenuated by more than 20dB below the permissible value has no need to be reported.

Emission level (dBuV/m) = 20 log Emission level (uV/m).

Corrected Reading: Antenna Factor + Cable Loss + Read Level - Preamp Factor = Level.

4.6.9. Results for Radiated Emissions (1GHz~40GHz)

Temperature	24.5°C	Humidity	57%
Test Engineer	Jim Huang	Configurations	IEEE 802.11n MCS0 HT20MHz Ch 36 / Chain 1 (1TX)
Test Date	Dec. 06, 2012		

Horizontal

	Freq	Level	Limit Line	Over Limit	Read Level	CableAntenna Loss	Antenna Factor	Preamp Factor	Remark	A/Pos	T/Pos	Pol/Phase
	MHz	dBuV/m	dBuV/m	dB	dBuV	dB	dB/m	dB		cm	deg	
1	15548.76	56.16	74.00	-17.84	43.04	10.59	38.12	35.59	Peak	100	306	HORIZONTAL
2	15549.56	43.92	54.00	-10.08	30.80	10.59	38.12	35.59	Average	100	306	HORIZONTAL

Vertical

	Freq	Level	Limit Line	Over Limit	Read Level	CableAntenna Loss	Antenna Factor	Preamp Factor	Remark	A/Pos	T/Pos	Pol/Phase
	MHz	dBuV/m	dBuV/m	dB	dBuV	dB	dB/m	dB		cm	deg	
1	15548.20	44.20	54.00	-9.80	31.08	10.59	38.12	35.59	Average	100	207	VERTICAL
2	15548.56	55.78	74.00	-18.22	42.66	10.59	38.12	35.59	Peak	100	207	VERTICAL



Temperature	24.5°C	Humidity	57%
Test Engineer	Jim Huang	Configurations	IEEE 802.11n MCS0 HT20MHz Ch 40 / Chain 1 (1TX)
Test Date	Dec. 06, 2012		

Horizontal

	Freq	Level	Limit	Over	Read	CableAntenna	Preamp	Remark	A/Pos	T/Pos	Pol/Phase
	MHz	dBuV/m	dBuV/m	dB	dBuV	dB	dB/m	dB	cm	deg	
1	15595.36	56.36	74.00	-17.64	43.30	10.60	38.04	35.58	Peak	100	194 HORIZONTAL
2	15595.80	43.64	54.00	-10.36	30.58	10.60	38.04	35.58	Average	100	194 HORIZONTAL

Vertical

	Freq	Level	Limit	Over	Read	CableAntenna	Preamp	Remark	A/Pos	T/Pos	Pol/Phase
	MHz	dBuV/m	dBuV/m	dB	dBuV	dB	dB/m	dB	cm	deg	
1	15601.72	55.39	74.00	-18.61	42.33	10.60	38.04	35.58	Peak	100	105 VERTICAL
2	15601.84	43.70	54.00	-10.30	30.64	10.60	38.04	35.58	Average	100	105 VERTICAL



Temperature	24.5°C	Humidity	57%
Test Engineer	Jim Huang	Configurations	IEEE 802.11n MCS0 HT20MHz Ch 48 / Chain 1 (1TX)
Test Date	Dec. 06, 2012		

Horizontal

	Freq	Level	Limit	Over	Read	CableAntenna	Preamp	Remark	A/Pos	T/Pos	Pol/Phase
	MHz	dBuV/m	dBuV/m	dB	dBuV	dB	dB/m	dB	cm	deg	
1	15719.72	55.10	74.00	-18.90	42.17	10.64	37.85	35.56 Peak	100	95	HORIZONTAL
2	15720.12	42.88	54.00	-11.12	29.95	10.64	37.85	35.56 Average	100	95	HORIZONTAL

Vertical

	Freq	Level	Limit	Over	Read	CableAntenna	Preamp	Remark	A/Pos	T/Pos	Pol/Phase
	MHz	dBuV/m	dBuV/m	dB	dBuV	dB	dB/m	dB	cm	deg	
1	15725.44	54.39	74.00	-19.61	41.48	10.64	37.83	35.56 Peak	100	188	VERTICAL
2	15725.72	43.45	54.00	-10.55	30.54	10.64	37.83	35.56 Average	100	188	VERTICAL



Temperature	24.5°C	Humidity	57%
Test Engineer	Jim Huang	Configurations	IEEE 802.11n MCS0 HT40MHz Ch 38 / Chain 1 (1TX)
Test Date	Dec. 06, 2012		

Horizontal

	Freq	Level	Limit	Over	Read	CableAntenna	Preamp		A/Pos	T/Pos	Pol/Phase	
	MHz	dBuV/m	dBuV/m	dB	dBuV	dB	dB/m	dB	cm	deg		
1	15570.80	43.84	54.00	-10.16	30.73	10.60	38.09	35.58	Average	100	200	HORIZONTAL
2	15571.16	56.07	74.00	-17.93	42.96	10.60	38.09	35.58	Peak	100	200	HORIZONTAL

Vertical

	Freq	Level	Limit	Over	Read	CableAntenna	Preamp		A/Pos	T/Pos	Pol/Phase	
	MHz	dBuV/m	dBuV/m	dB	dBuV	dB	dB/m	dB	cm	deg		
1	15568.68	55.50	74.00	-18.50	42.39	10.60	38.09	35.58	Peak	100	108	VERTICAL
2	15569.12	43.73	54.00	-10.27	30.62	10.60	38.09	35.58	Average	100	108	VERTICAL



Temperature	24.5°C	Humidity	57%
Test Engineer	Jim Huang	Configurations	IEEE 802.11n MCS0 HT40MHz Ch 46 / Chain 1 (1TX)
Test Date	Dec. 06, 2012		

Horizontal

	Freq	Level	Limit	Over	Read	CableAntenna	Preamp	Remark	A/Pos	T/Pos	Pol/Phase
	MHz	dBuV/m	dBuV/m	dB	dBuV	dB	dB/m	dB	cm	deg	
1	15684.96	43.98	54.00	-10.02	31.01	10.62	37.91	35.56 Average	100	133	HORIZONTAL
2	15685.00	55.09	74.00	-18.91	42.12	10.62	37.91	35.56 Peak	100	133	HORIZONTAL

Vertical

	Freq	Level	Limit	Over	Read	CableAntenna	Preamp	Remark	A/Pos	T/Pos	Pol/Phase
	MHz	dBuV/m	dBuV/m	dB	dBuV	dB	dB/m	dB	cm	deg	
1	15685.20	43.76	54.00	-10.24	30.79	10.62	37.91	35.56 Average	100	244	VERTICAL
2	15685.84	57.03	74.00	-16.97	44.06	10.62	37.91	35.56 Peak	100	244	VERTICAL



Temperature	24.5°C	Humidity	57%
Test Engineer	Jim Huang	Configurations	IEEE 802.11n MCS8 HT20MHz Ch 36 / Chain 1 + Chain 2 (2TX)
Test Date	Dec. 06, 2012		

Horizontal

	Freq	Level	Limit	Over	Read	CableAntenna	Preamp	Remark	A/Pos	T/Pos	Pol/Phase
	MHz	dBuV/m	dBuV/m	dB	dBuV	dB	dB/m	dB	cm	deg	
1	15535.76	43.88	54.00	-10.12	30.74	10.58	38.15	35.59 Average	100	99	HORIZONTAL
2	15536.00	56.24	74.00	-17.76	43.10	10.58	38.15	35.59 Peak	100	99	HORIZONTAL

Vertical

	Freq	Level	Limit	Over	Read	CableAntenna	Preamp	Remark	A/Pos	T/Pos	Pol/Phase
	MHz	dBuV/m	dBuV/m	dB	dBuV	dB	dB/m	dB	cm	deg	
1	15530.80	43.86	54.00	-10.14	30.72	10.58	38.15	35.59 Average	100	198	VERTICAL
2	15531.28	56.40	74.00	-17.60	43.26	10.58	38.15	35.59 Peak	100	198	VERTICAL



Temperature	24.5°C	Humidity	57%
Test Engineer	Jim Huang	Configurations	IEEE 802.11n MCS8 HT20MHz Ch 40 / Chain 1 + Chain 2 (2TX)
Test Date	Dec. 06, 2012		

Horizontal

	Freq	Level	Limit	Over	Read	CableAntenna	Preamp	Remark	A/Pos	T/Pos	Pol/Phase
	MHz	dBuV/m	dBuV/m	dB	dBuV	dB	dB/m	dB	cm	deg	
1	15606.52	43.77	54.00	-10.23	30.74	10.60	38.01	35.58 Average	100	254	HORIZONTAL
2	15606.64	55.59	74.00	-18.41	42.56	10.60	38.01	35.58 Peak	100	254	HORIZONTAL

Vertical

	Freq	Level	Limit	Over	Read	CableAntenna	Preamp	Remark	A/Pos	T/Pos	Pol/Phase
	MHz	dBuV/m	dBuV/m	dB	dBuV	dB	dB/m	dB	cm	deg	
1	15606.76	56.32	74.00	-17.68	43.29	10.60	38.01	35.58 Peak	100	124	VERTICAL
2	15608.40	43.56	54.00	-10.44	30.52	10.60	38.01	35.57 Average	100	124	VERTICAL



Temperature	24.5°C	Humidity	57%
Test Engineer	Jim Huang	Configurations	IEEE 802.11n MCS8 HT20MHz Ch 48 / Chain 1 + Chain 2 (2TX)
Test Date	Dec. 06, 2012		

Horizontal

	Freq	Level	Limit Line	Over Limit	Read Level	CableAntenna Loss	Antenna Factor	Preamp Factor	Remark	A/Pos	T/Pos	Pol/Phase
	MHz	dBuV/m	dBuV/m	dB	dBuV	dB	dB/m	dB		cm	deg	
1	15727.64	43.42	54.00	-10.58	30.51	10.64	37.83	35.56	Average	100	147	HORIZONTAL
2	15727.84	55.92	74.00	-18.08	43.01	10.64	37.83	35.56	Peak	100	147	HORIZONTAL

Vertical

	Freq	Level	Limit Line	Over Limit	Read Level	CableAntenna Loss	Antenna Factor	Preamp Factor	Remark	A/Pos	T/Pos	Pol/Phase
	MHz	dBuV/m	dBuV/m	dB	dBuV	dB	dB/m	dB		cm	deg	
1	15715.84	55.36	74.00	-18.64	42.43	10.64	37.85	35.56	Peak	100	254	VERTICAL
2	15716.16	43.42	54.00	-10.58	30.49	10.64	37.85	35.56	Average	100	254	VERTICAL



Temperature	24.5°C	Humidity	57%
Test Engineer	Jim Huang	Configurations	IEEE 802.11n MCS8 HT40MHz Ch 38 / Chain 1 + Chain 2 (2TX)
Test Date	Dec. 06, 2012		

Horizontal

	Freq	Level	Limit	Over	Read	CableAntenna	Preamp	Remark	A/Pos	T/Pos	Pol/Phase
	MHz	dBuV/m	dBuV/m	dB	dBuV	dB	dB/m	dB	cm	deg	
1	15565.12	55.78	74.00	-18.22	42.67	10.60	38.09	35.58	Peak	100	243 HORIZONTAL
2	15565.56	43.44	54.00	-10.56	30.33	10.60	38.09	35.58	Average	100	243 HORIZONTAL

Vertical

	Freq	Level	Limit	Over	Read	CableAntenna	Preamp	Remark	A/Pos	T/Pos	Pol/Phase
	MHz	dBuV/m	dBuV/m	dB	dBuV	dB	dB/m	dB	cm	deg	
1	15561.44	55.31	74.00	-18.69	42.21	10.59	38.09	35.58	Peak	100	315 VERTICAL
2	15561.84	43.65	54.00	-10.35	30.55	10.59	38.09	35.58	Average	100	315 VERTICAL



Temperature	24.5°C	Humidity	57%
Test Engineer	Jim Huang	Configurations	IEEE 802.11n MCS8 HT40MHz Ch 46 / Chain 1 + Chain 2 (2TX)
Test Date	Dec. 06, 2012		

Horizontal

	Freq	Level	Limit	Over	Read	CableAntenna	Preamp	Remark	A/Pos	T/Pos	Pol/Phase
	MHz	dBuV/m	dBuV/m	dB	dBuV	dB	dB/m	dB	cm	deg	
1	15683.44	54.67	74.00	-19.33	41.70	10.62	37.91	35.56 Peak	100	304	HORIZONTAL
2	15683.56	43.81	54.00	-10.19	30.84	10.62	37.91	35.56 Average	100	304	HORIZONTAL

Vertical

	Freq	Level	Limit	Over	Read	CableAntenna	Preamp	Remark	A/Pos	T/Pos	Pol/Phase
	MHz	dBuV/m	dBuV/m	dB	dBuV	dB	dB/m	dB	cm	deg	
1	15682.80	43.56	54.00	-10.44	30.59	10.62	37.91	35.56 Average	100	170	VERTICAL
2	15683.28	55.58	74.00	-18.42	42.61	10.62	37.91	35.56 Peak	100	170	VERTICAL



Temperature	24.5°C	Humidity	57%
Test Engineer	Jim Huang	Configurations	IEEE 802.11ac MCS0-Nss1 VHT80MHz Ch 42 / Chain 1 (1TX)
Test Date	Dec. 06, 2012		

Horizontal

	Freq	Level	Limit	Over	Read	CableAntenna	Preamp	Remark	A/Pos	T/Pos	Pol/Phase
	MHz	dBuV/m	dBuV/m	dB	dBuV	dB	dB/m	dB	cm	deg	
1	15635.60	43.95	54.00	-10.05	30.92	10.61	37.99	35.57 Average	100	69	HORIZONTAL
2	15635.80	55.66	74.00	-18.34	42.63	10.61	37.99	35.57 Peak	100	69	HORIZONTAL

Vertical

	Freq	Level	Limit	Over	Read	CableAntenna	Preamp	Remark	A/Pos	T/Pos	Pol/Phase
	MHz	dBuV/m	dBuV/m	dB	dBuV	dB	dB/m	dB	cm	deg	
1	15657.80	56.34	74.00	-17.66	43.36	10.62	37.93	35.57 Peak	100	191	VERTICAL
2	15658.20	44.14	54.00	-9.86	31.16	10.62	37.93	35.57 Average	100	191	VERTICAL



Temperature	24.5°C	Humidity	57%
Test Engineer	Jim Huang	Configurations	IEEE 802.11ac MCS0-Nss2 VHT80MHz Ch 42 / Chain 1 + Chain 2 (2TX)
Test Date	Dec. 06, 2012		

Horizontal

	Freq	Level	Limit	Over	Read	CableAntenna	Preamp	Remark	A/Pos	T/Pos	Pol/Phase
	MHz	dBuV/m	dBuV/m	dB	dBuV	dB	dB/m	dB	cm	deg	
1	15625.80	55.26	74.00	-18.74	42.23	10.61	37.99	35.57 Peak	100	236	HORIZONTAL
2	15626.00	43.89	54.00	-10.11	30.86	10.61	37.99	35.57 Average	100	236	HORIZONTAL

Vertical

	Freq	Level	Limit	Over	Read	CableAntenna	Preamp	Remark	A/Pos	T/Pos	Pol/Phase
	MHz	dBuV/m	dBuV/m	dB	dBuV	dB	dB/m	dB	cm	deg	
1	15668.80	44.24	54.00	-9.76	31.25	10.62	37.93	35.56 Average	100	146	VERTICAL
2	15669.20	55.62	74.00	-18.38	42.63	10.62	37.93	35.56 Peak	100	146	VERTICAL



Temperature	24.5°C	Humidity	57%
Test Engineer	Jim Huang	Configurations	IEEE 802.11a Ch 36 / Chain 1 (1TX)
Test Date	Dec. 06, 2012		

Horizontal

	Freq	Level	Limit	Over	Read	CableAntenna	Preamp	Remark	A/Pos	T/Pos	Pol/Phase
	MHz	dBuV/m	dBuV/m	dB	dBuV	dB	dB/m	dB	cm	deg	
1	15543.76	56.22	74.00	-17.78	43.10	10.59	38.12	35.59	100	72	HORIZONTAL
2	15543.88	43.97	54.00	-10.03	30.85	10.59	38.12	35.59	100	72	HORIZONTAL

Vertical

	Freq	Level	Limit	Over	Read	CableAntenna	Preamp	Remark	A/Pos	T/Pos	Pol/Phase
	MHz	dBuV/m	dBuV/m	dB	dBuV	dB	dB/m	dB	cm	deg	
1	15540.16	44.14	54.00	-9.86	31.02	10.59	38.12	35.59	100	202	VERTICAL
2	15540.32	56.82	74.00	-17.18	43.70	10.59	38.12	35.59	100	202	VERTICAL



Temperature	24.5°C	Humidity	57%
Test Engineer	Jim Huang	Configurations	IEEE 802.11a Ch 40 / Chain 1 (1TX)
Test Date	Dec. 06, 2012		

Horizontal

	Freq	Level	Limit Line	Over Limit	Read Level	CableAntenna Loss	Antenna Factor	Preamp Factor	Remark	A/Pos	T/Pos	Pol/Phase
	MHz	dBuV/m	dBuV/m	dB	dBuV	dB	dB/m	dB		cm	deg	
1	15608.68	43.84	54.00	-10.16	30.80	10.60	38.01	35.57	Average	100	72	HORIZONTAL
2	15608.92	55.19	74.00	-18.81	42.15	10.60	38.01	35.57	Peak	100	72	HORIZONTAL

Vertical

	Freq	Level	Limit Line	Over Limit	Read Level	CableAntenna Loss	Antenna Factor	Preamp Factor	Remark	A/Pos	T/Pos	Pol/Phase
	MHz	dBuV/m	dBuV/m	dB	dBuV	dB	dB/m	dB		cm	deg	
1	15606.52	43.80	54.00	-10.20	30.77	10.60	38.01	35.58	Average	100	154	VERTICAL
2	15606.64	54.93	74.00	-19.07	41.90	10.60	38.01	35.58	Peak	100	154	VERTICAL



Temperature	24.5°C	Humidity	57%
Test Engineer	Jim Huang	Configurations	IEEE 802.11a Ch 48 / Chain 1 (1TX)
Test Date	Dec. 06, 2012		

Horizontal

	Freq	Level	Limit Line	Over Limit	Read Level	CableAntenna Loss	Antenna Factor	Preamp Factor	Remark	A/Pos	T/Pos	Pol/Phase
	MHz	dBuV/m	dBuV/m	dB	dBuV	dB	dB/m	dB		cm	deg	
1	15716.56	55.80	74.00	-18.20	42.87	10.64	37.85	35.56	Peak	100	128	HORIZONTAL
2	15716.88	43.40	54.00	-10.60	30.47	10.64	37.85	35.56	Average	100	128	HORIZONTAL

Vertical

	Freq	Level	Limit Line	Over Limit	Read Level	CableAntenna Loss	Antenna Factor	Preamp Factor	Remark	A/Pos	T/Pos	Pol/Phase
	MHz	dBuV/m	dBuV/m	dB	dBuV	dB	dB/m	dB		cm	deg	
1	15723.28	43.27	54.00	-10.73	30.34	10.64	37.85	35.56	Average	100	232	VERTICAL
2	15723.40	55.17	74.00	-18.83	42.24	10.64	37.85	35.56	Peak	100	232	VERTICAL

Note:

The amplitude of spurious emissions that are attenuated by more than 20dB below the permissible value has no need to be reported.

Emission level (dBuV/m) = 20 log Emission level (uV/m).

Corrected Reading: Antenna Factor + Cable Loss + Read Level - Preamp Factor = Level.

4.7. Band Edge Emissions Measurement

4.7.1. Limit

For transmitters operating in the 5.15-5.35 GHz band: all emissions outside of the 5.15-5.35 GHz band shall not exceed an EIRP of -27 dBm/MHz (68.3dBuV/m at 3m). In addition, In case the emission fall within the restricted band specified on 15.205(a), then the 15.209(a) limit in the table below has to be followed.

Frequencies (MHz)	Field Strength (micorvolts/meter)	Measurement Distance (meters)
0.009~0.490	2400/F(KHz)	300
0.490~1.705	24000/F(KHz)	30
1.705~30.0	30	30
30~88	100	3
88~216	150	3
216~960	200	3
Above 960	500	3

4.7.2. Measuring Instruments and Setting

Please refer to section 5 of equipments list in this report. The following table is the setting of the spectrum analyzer.

Spectrum Parameter	Setting
Attenuation	Auto
Span Frequency	100 MHz
RB / VB (Emission in restricted band)	1MHz / 3MHz for Peak, 1 MHz / 10Hz for Average
RB / VB (Emission in non-restricted band)	1 MHz / 3MHz for Peak

4.7.3. Test Procedures

1. The test procedure is the same as section 4.6.3, only the frequency range investigated is limited to 100MHz around bandedges.
2. In case the emission is fail due to the used RB/VB is too wide, marker-delta method of FCC Public Notice DA00-705 will be followed.

4.7.4. Test Setup Layout

This test setup layout is the same as that shown in section 4.6.4.

4.7.5. Test Deviation

There is no deviation with the original standard.

4.7.6. EUT Operation during Test

The EUT was programmed to be in continuously transmitting mode.

4.7.7. Test Result of Band Edge and Fundamental Emissions

Temperature	24.5°C	Humidity	57%
Test Engineer	Jim Huang	Configurations	IEEE 802.11n MCS0 20MHz Ch 36, 40, 48 / Chain 1 (1TX)
Test Date	Dec. 06, 2012		

Channel 36

	Freq	Level	Limit	Over	Read	CableAntenna	Preamp	Remark	A/Pos	T/Pos	Pol/Phase
	MHz	dBuV/m	dBuV/m	dB	dBuV	dB	dB/m	dB	cm	deg	
1	5150.00	53.38	54.00	-0.62	12.88	6.49	34.01	0.00 Average	100	292	VERTICAL
2	5150.00	71.13	74.00	-2.87	30.63	6.49	34.01	0.00 Peak	100	292	VERTICAL
3	5185.35	102.86			62.27	6.51	34.08	0.00 Average	100	292	VERTICAL
4	5185.93	112.01			71.42	6.51	34.08	0.00 Peak	100	292	VERTICAL

Item 3, 4 are the fundamental frequency at 5180 MHz.

Channel 40

	Freq	Level	Limit	Over	Read	CableAntenna	Preamp	Remark	A/Pos	T/Pos	Pol/Phase
	MHz	dBuV/m	dBuV/m	dB	dBuV	dB	dB/m	dB	cm	deg	
1	5150.00	48.87	54.00	-5.13	8.37	6.49	34.01	0.00 Average	100	282	VERTICAL
2	5150.00	67.20	74.00	-6.80	26.70	6.49	34.01	0.00 Peak	100	282	VERTICAL
3	5205.20	106.51			65.88	6.52	34.11	0.00 Average	100	282	VERTICAL
4	5206.40	116.12			75.49	6.52	34.11	0.00 Peak	100	282	VERTICAL

Item 3, 4 are the fundamental frequency at 5200 MHz.

Channel 48

	Freq	Level	Limit	Over	Read	CableAntenna	Preamp	Remark	A/Pos	T/Pos	Pol/Phase
	MHz	dBuV/m	dBuV/m	dB	dBuV	dB	dB/m	dB	cm	deg	
1	5148.80	56.58	74.00	-17.42	16.08	6.49	34.01	0.00 Peak	100	290	VERTICAL
2	5150.00	43.93	54.00	-10.07	3.43	6.49	34.01	0.00 Average	100	290	VERTICAL
3	5245.20	106.45			65.71	6.56	34.18	0.00 Average	100	290	VERTICAL
4	5246.40	116.07			75.29	6.56	34.22	0.00 Peak	100	290	VERTICAL

Item 3, 4 are the fundamental frequency at 5240 MHz.

Note:

Emission level (dBuV/m) = 20 log Emission level (uV/m)

Corrected Reading: Antenna Factor + Cable Loss + Read Level - Preamp Factor = Level



Temperature	24.5°C	Humidity	57%
Test Engineer	Jim Huang	Configurations	IEEE 802.11n MCS0 40MHz Ch 38, 46 / Chain 1 (1TX)
Test Date	Dec. 06, 2012		

Channel 38

	Freq	Level	Limit Line	Over Limit	Read Level	CableAntenna Loss	Preamp Factor	Remark	A/Pos	T/Pos	Pol/Phase
	MHz	dBuV/m	dBuV/m	dB	dBuV	dB	dB/m	dB	cm	deg	
1	5150.00	52.88	54.00	-1.12	12.38	6.49	34.01	0.00 Average	100	292	VERTICAL
2	5150.00	65.93	74.00	-8.07	25.43	6.49	34.01	0.00 Peak	100	292	VERTICAL
3	5188.00	103.67			63.07	6.52	34.08	0.00 Peak	100	292	VERTICAL
4	5191.60	94.42			53.82	6.52	34.08	0.00 Average	100	292	VERTICAL

Item 3, 4 are the fundamental frequency at 5190 MHz.

Channel 46

	Freq	Level	Limit Line	Over Limit	Read Level	CableAntenna Loss	Preamp Factor	Remark	A/Pos	T/Pos	Pol/Phase
	MHz	dBuV/m	dBuV/m	dB	dBuV	dB	dB/m	dB	cm	deg	
1	5149.20	69.01	74.00	-4.99	28.51	6.49	34.01	0.00 Peak	100	78	VERTICAL
2	5150.00	51.83	54.00	-2.17	11.33	6.49	34.01	0.00 Average	100	78	VERTICAL
3	5232.80	102.16			61.44	6.54	34.18	0.00 Average	100	78	VERTICAL
4	5233.60	111.77			71.05	6.54	34.18	0.00 Peak	100	78	VERTICAL

Item 3, 4 are the fundamental frequency at 5230 MHz.

Note:

Emission level (dBuV/m) = 20 log Emission level (uV/m)

Corrected Reading: Antenna Factor + Cable Loss + Read Level - Preamp Factor = Level



Temperature	24.5°C	Humidity	57%
Test Engineer	Jim Huang	Configurations	IEEE 802.11n MCS8 20MHz Ch 36, 40, 48 / Chain 1 + Chain 2 (2TX)
Test Date	Dec. 06, 2012		

Channel 36

	Freq	Level	Limit Line	Over Limit	Read Level	CableAntenna Loss	Antenna Factor	Preamp Factor	Remark	A/Pos	T/Pos	Pol/Phase
	MHz	dBuV/m	dBuV/m	dB	dBuV	dB	dB/m	dB		cm	deg	
1	5150.00	52.91	54.00	-1.09	12.41	6.49	34.01	0.00	Average	100	283	VERTICAL
2	5150.00	69.16	74.00	-4.84	28.66	6.49	34.01	0.00	Peak	100	283	VERTICAL
3	5185.20	116.76			76.17	6.51	34.08	0.00	Peak	100	283	VERTICAL
4	5186.20	105.74			65.15	6.51	34.08	0.00	Average	100	283	VERTICAL

Item 3, 4 are the fundamental frequency at 5180 MHz.

Channel 40

	Freq	Level	Limit Line	Over Limit	Read Level	CableAntenna Loss	Antenna Factor	Preamp Factor	Remark	A/Pos	T/Pos	Pol/Phase
	MHz	dBuV/m	dBuV/m	dB	dBuV	dB	dB/m	dB		cm	deg	
1	5116.40	46.88	54.00	-7.12	6.46	6.48	33.94	0.00	Average	101	78	VERTICAL
2	5123.20	59.97	74.00	-14.03	19.55	6.48	33.94	0.00	Peak	101	78	VERTICAL
3	5206.00	119.77			79.14	6.52	34.11	0.00	Peak	101	78	VERTICAL
4	5206.40	107.91			67.28	6.52	34.11	0.00	Average	101	78	VERTICAL

Item 3, 4 are the fundamental frequency at 5200 MHz.

Channel 48

	Freq	Level	Limit Line	Over Limit	Read Level	CableAntenna Loss	Antenna Factor	Preamp Factor	Remark	A/Pos	T/Pos	Pol/Phase
	MHz	dBuV/m	dBuV/m	dB	dBuV	dB	dB/m	dB		cm	deg	
1	5148.40	56.10	74.00	-17.90	15.60	6.49	34.01	0.00	Peak	100	78	VERTICAL
2	5150.00	44.00	54.00	-10.00	3.50	6.49	34.01	0.00	Average	100	78	VERTICAL
3	5246.00	119.95			79.17	6.56	34.22	0.00	Peak	100	78	VERTICAL
4	5246.40	108.79			68.01	6.56	34.22	0.00	Average	100	78	VERTICAL

Item 3, 4 are the fundamental frequency at 5240 MHz.

Note:

Emission level (dBuV/m) = 20 log Emission level (uV/m)

Corrected Reading: Antenna Factor + Cable Loss + Read Level - Preamp Factor = Level



Temperature	24.5°C	Humidity	57%
Test Engineer	Jim Huang	Configurations	IEEE 802.11n MCS8 40MHz Ch 38, 46 / Chain 1 + Chain 2 (2TX)
Test Date	Dec. 06, 2012		

Channel 38

	Freq	Level	Limit Line	Over Limit	Read Level	CableAntenna Loss	Preamp Factor	Remark	A/Pos	T/Pos	Pol/Phase
	MHz	dBuV/m	dBuV/m	dB	dBuV	dB	dB/m	dB	cm	deg	
1	5150.00	52.91	54.00	-1.09	12.41	6.49	34.01	0.00 Average	100	82	VERTICAL
2	5150.00	66.96	74.00	-7.04	26.46	6.49	34.01	0.00 Peak	100	82	VERTICAL
3	5191.20	109.02			68.42	6.52	34.08	0.00 Peak	100	82	VERTICAL
4	5191.60	97.42			56.82	6.52	34.08	0.00 Average	100	82	VERTICAL

Item 3, 4 are the fundamental frequency at 5190 MHz.

Channel 46

	Freq	Level	Limit Line	Over Limit	Read Level	CableAntenna Loss	Preamp Factor	Remark	A/Pos	T/Pos	Pol/Phase
	MHz	dBuV/m	dBuV/m	dB	dBuV	dB	dB/m	dB	cm	deg	
1	5150.00	50.33	54.00	-3.67	9.83	6.49	34.01	0.00 Average	100	78	VERTICAL
2	5150.00	63.51	74.00	-10.49	23.01	6.49	34.01	0.00 Peak	100	78	VERTICAL
3	5245.20	105.09			64.35	6.56	34.18	0.00 Average	100	78	VERTICAL
4	5245.60	115.80			75.02	6.56	34.22	0.00 Peak	100	78	VERTICAL

Item 3, 4 are the fundamental frequency at 5230 MHz.

Note:

Emission level (dBuV/m) = 20 log Emission level (uV/m)

Corrected Reading: Antenna Factor + Cable Loss + Read Level - Preamp Factor = Level



Temperature	24.5°C	Humidity	57%
Test Engineer	Jim Huang	Configurations	IEEE 802.11ac MCS0-Nss1 VHT20MHz Ch 36, 40, 48 / Chain 1 (1TX)
Test Date	Dec. 06, 2012		

Channel 36

	Freq	Level	Limit	Over	Read	CableAntenna	Preamp	Remark	A/Pos	T/Pos	Pol/Phase
	MHz	dBuV/m	dBuV/m	dB	dBuV	dB	dB/m	dB	cm	deg	
1	5150.00	53.04	54.00	-0.96	12.54	6.49	34.01	0.00 Average	100	291	VERTICAL
2	5150.00	72.31	74.00	-1.69	31.81	6.49	34.01	0.00 Peak	100	291	VERTICAL
3	5185.40	103.09			62.50	6.51	34.08	0.00 Average	100	291	VERTICAL
4	5186.20	112.55			71.96	6.51	34.08	0.00 Peak	100	291	VERTICAL

Item 3, 4 are the fundamental frequency at 5180 MHz.

Channel 40

	Freq	Level	Limit	Over	Read	CableAntenna	Preamp	Remark	A/Pos	T/Pos	Pol/Phase
	MHz	dBuV/m	dBuV/m	dB	dBuV	dB	dB/m	dB	cm	deg	
1	5147.20	66.84	74.00	-7.16	26.34	6.49	34.01	0.00 Peak	100	282	VERTICAL
2	5150.00	48.75	54.00	-5.25	8.25	6.49	34.01	0.00 Average	100	282	VERTICAL
3	5202.80	114.59			73.96	6.52	34.11	0.00 Peak	100	282	VERTICAL
4	5205.20	105.05			64.42	6.52	34.11	0.00 Average	100	282	VERTICAL

Item 3, 4 are the fundamental frequency at 5200 MHz.

Channel 48

	Freq	Level	Limit	Over	Read	CableAntenna	Preamp	Remark	A/Pos	T/Pos	Pol/Phase
	MHz	dBuV/m	dBuV/m	dB	dBuV	dB	dB/m	dB	cm	deg	
1	5150.00	43.46	54.00	-10.54	2.96	6.49	34.01	0.00 Average	100	282	VERTICAL
2	5150.00	56.56	74.00	-17.44	16.06	6.49	34.01	0.00 Peak	100	282	VERTICAL
3	5245.60	106.49			65.71	6.56	34.22	0.00 Average	100	282	VERTICAL
4	5246.00	115.79			75.01	6.56	34.22	0.00 Peak	100	282	VERTICAL

Item 3, 4 are the fundamental frequency at 5240 MHz.

Note:

Emission level (dBuV/m) = 20 log Emission level (uV/m)

Corrected Reading: Antenna Factor + Cable Loss + Read Level - Preamp Factor = Level



Temperature	24.5°C	Humidity	57%
Test Engineer	Jim Huang	Configurations	IEEE 802.11ac MCS0-Nss1 VHT40MHz Ch 38, 46 / Chain 1 (1TX)
Test Date	Dec. 06, 2012		

Channel 38

	Freq	Level	Limit	Over	Read	CableAntenna	Preamp	Remark	A/Pos	T/Pos	Pol/Phase
	MHz	dBuV/m	dBuV/m	dB	dBuV	dB	dB/m	dB	cm	deg	
1	5150.00	52.82	54.00	-1.18	12.32	6.49	34.01	0.00 Average	100	291	VERTICAL
2	5150.00	65.24	74.00	-8.76	24.74	6.49	34.01	0.00 Peak	100	291	VERTICAL
3	5191.60	94.77			54.17	6.52	34.08	0.00 Average	100	291	VERTICAL
4	5192.80	104.42			63.82	6.52	34.08	0.00 Peak	100	291	VERTICAL

Item 3, 4 are the fundamental frequency at 5190 MHz.

Channel 46

	Freq	Level	Limit	Over	Read	CableAntenna	Preamp	Remark	A/Pos	T/Pos	Pol/Phase
	MHz	dBuV/m	dBuV/m	dB	dBuV	dB	dB/m	dB	cm	deg	
1	5150.00	51.72	54.00	-2.28	11.22	6.49	34.01	0.00 Average	100	80	VERTICAL
2	5150.00	68.00	74.00	-6.00	27.50	6.49	34.01	0.00 Peak	100	80	VERTICAL
3	5244.80	112.15			71.41	6.56	34.18	0.00 Peak	100	80	VERTICAL
4	5245.60	102.87			62.09	6.56	34.22	0.00 Average	100	80	VERTICAL

Item 3, 4 are the fundamental frequency at 5230 MHz.

Note:

Emission level (dBuV/m) = 20 log Emission level (uV/m)

Corrected Reading: Antenna Factor + Cable Loss + Read Level - Preamp Factor = Level



Temperature	24.5°C	Humidity	57%
Test Engineer	Jim Huang	Configurations	IEEE 802.11ac MCS0-Nss1 VHT80MHz Ch 42 / Chain 1 (1TX)
Test Date	Dec. 06, 2012		

Channel 42

	Freq	Level	Limit	Over	Read	CableAntenna	Preamp	Remark	A/Pos	T/Pos	Pol/Phase
	MHz	dBuV/m	Line	Limit	Level	Loss	Factor		cm	deg	
			dBuV/m	dB	dBuV	dB	dB/m	dB			
1	5149.00	67.03	74.00	-6.97	26.53	6.49	34.01	0.00	100	79	VERTICAL
2	5150.00	53.38	54.00	-0.62	12.88	6.49	34.01	0.00	100	79	VERTICAL
3	5219.00	91.60			50.91	6.54	34.15	0.00	100	79	VERTICAL
4	5220.00	100.82			60.13	6.54	34.15	0.00	100	79	VERTICAL

Item 3, 4 are the fundamental frequency at 5210 MHz.

Note:

Emission level (dBuV/m) = 20 log Emission level (uV/m)

Corrected Reading: Antenna Factor + Cable Loss + Read Level - Preamp Factor = Level

Temperature	24.5°C	Humidity	57%
Test Engineer	Jim Huang	Configurations	IEEE 802.11ac MCS0-Nss2 VHT20MHz Ch 36, 40, 48 / Chain 1 + Chain 2 (2TX)
Test Date	Dec. 06, 2012		

Channel 36

	Freq	Level	Limit	Over	Read	CableAntenna	Preamp	Remark	A/Pos	T/Pos	Pol/Phase
	MHz	dBuV/m	dBuV/m	dB	dBuV	dB	dB/m	dB	cm	deg	
1	5150.00	53.34	54.00	-0.66	12.84	6.49	34.01	0.00	100	283	VERTICAL
2	5150.00	70.67	74.00	-3.33	30.17	6.49	34.01	0.00	100	283	VERTICAL
3	5185.20	116.68			76.09	6.51	34.08	0.00	100	283	VERTICAL
4	5185.80	105.56			64.97	6.51	34.08	0.00	100	283	VERTICAL

Item 3, 4 are the fundamental frequency at 5180 MHz.

Channel 40

	Freq	Level	Limit	Over	Read	CableAntenna	Preamp	Remark	A/Pos	T/Pos	Pol/Phase
	MHz	dBuV/m	dBuV/m	dB	dBuV	dB	dB/m	dB	cm	deg	
1	5113.20	46.15	54.00	-7.85	5.73	6.48	33.94	0.00	100	282	VERTICAL
2	5114.00	58.91	74.00	-15.09	18.49	6.48	33.94	0.00	100	282	VERTICAL
3	5193.20	118.54			77.94	6.52	34.08	0.00	100	282	VERTICAL
4	5193.60	107.68			67.08	6.52	34.08	0.00	100	282	VERTICAL

Item 3, 4 are the fundamental frequency at 5200 MHz.

Channel 48

	Freq	Level	Limit	Over	Read	CableAntenna	Preamp	Remark	A/Pos	T/Pos	Pol/Phase
	MHz	dBuV/m	dBuV/m	dB	dBuV	dB	dB/m	dB	cm	deg	
1	5150.00	43.80	54.00	-10.20	3.30	6.49	34.01	0.00	100	283	VERTICAL
2	5150.00	55.87	74.00	-18.13	15.37	6.49	34.01	0.00	100	283	VERTICAL
3	5246.40	109.19			68.41	6.56	34.22	0.00	100	283	VERTICAL
4	5246.40	119.22			78.44	6.56	34.22	0.00	100	283	VERTICAL

Item 3, 4 are the fundamental frequency at 5240 MHz.

Note:

Emission level (dBuV/m) = 20 log Emission level (uV/m)

Corrected Reading: Antenna Factor + Cable Loss + Read Level - Preamp Factor = Level



Temperature	24.5°C	Humidity	57%
Test Engineer	Jim Huang	Configurations	IEEE 802.11ac MCS0-Nss2 VHT40MHz Ch 38, 46 / Chain 1 + Chain 2 (2TX)
Test Date	Dec. 06, 2012		

Channel 38

	Freq	Level	Limit	Over	Read	CableAntenna	Preamp	Remark	A/Pos	T/Pos	Pol/Phase
	MHz	dBuV/m	dBuV/m	dB	dBuV	dB	dB/m	dB	cm	deg	
1	5150.00	52.86	54.00	-1.14	12.36	6.49	34.01	0.00 Average	100	284	VERTICAL
2	5150.00	67.63	74.00	-6.37	27.13	6.49	34.01	0.00 Peak	100	284	VERTICAL
3	5193.20	97.37			56.77	6.52	34.08	0.00 Average	100	284	VERTICAL
4	5194.80	108.08			67.45	6.52	34.11	0.00 Peak	100	284	VERTICAL

Item 3, 4 are the fundamental frequency at 5190 MHz.

Channel 46

	Freq	Level	Limit	Over	Read	CableAntenna	Preamp	Remark	A/Pos	T/Pos	Pol/Phase
	MHz	dBuV/m	dBuV/m	dB	dBuV	dB	dB/m	dB	cm	deg	
1	5148.80	62.00	74.00	-12.00	21.50	6.49	34.01	0.00 Peak	100	78	VERTICAL
2	5150.00	48.80	54.00	-5.20	8.30	6.49	34.01	0.00 Average	100	78	VERTICAL
3	5245.20	104.49			63.75	6.56	34.18	0.00 Average	100	78	VERTICAL
4	5245.20	115.17			74.43	6.56	34.18	0.00 Peak	100	78	VERTICAL

Item 3, 4 are the fundamental frequency at 5230 MHz.

Note:

Emission level (dBuV/m) = 20 log Emission level (uV/m)

Corrected Reading: Antenna Factor + Cable Loss + Read Level - Preamp Factor = Level



Temperature	24.5°C	Humidity	57%
Test Engineer	Jim Huang	Configurations	IEEE 802.11ac MCS0-Nss2 VHT80MHz Ch 42 / Chain 1 + Chain 2 (2TX)
Test Date	Dec. 06, 2012		

Channel 42

	Freq	Level	Limit	Over	Read	Cable	Antenna	Preamp	Remark	A/Pos	T/Pos	Pol/Phase
	MHz	dBuV/m	dBuV/m	dB	dBuV	Loss	Factor	Factor		cm	deg	
1	5150.00	52.97	54.00	-1.03	12.47	6.49	34.01	0.00	Average	100	78	VERTICAL
2	5150.00	66.94	74.00	-7.06	26.44	6.49	34.01	0.00	Peak	100	78	VERTICAL
3	5219.00	92.96			52.29	6.54	34.15	0.00	Average	100	78	VERTICAL
4	5245.00	104.19			63.45	6.56	34.18	0.00	Peak	100	78	VERTICAL

Item 3, 4 are the fundamental frequency at 5210 MHz.

Note:

Emission level (dBuV/m) = 20 log Emission level (uV/m)

Corrected Reading: Antenna Factor + Cable Loss + Read Level - Preamp Factor = Level

Temperature	24.5°C	Humidity	57%
Test Engineer	Jim Huang	Configurations	IEEE 802.11a Ch 36, 40, 48 / Chain 1 (1TX)
Test Date	Dec. 06, 2012		

Channel 36

	Freq	Level	Limit	Over	Read	CableAntenna	Preamp	Remark	A/Pos	T/Pos	Pol/Phase
	MHz	dBuV/m	dBuV/m	dB	dBuV	dB	dB/m	dB	cm	deg	
1	5150.00	52.89	54.00	-1.11	12.39	6.49	34.01	0.00 Average	100	292	VERTICAL
2	5150.00	69.71	74.00	-4.29	29.21	6.49	34.01	0.00 Peak	100	292	VERTICAL
3	5186.08	103.45			62.86	6.51	34.08	0.00 Average	100	292	VERTICAL
4	5186.66	112.34			71.75	6.51	34.08	0.00 Peak	100	292	VERTICAL

Item 5, 6 are the fundamental frequency at 5180 MHz.

Channel 40

	Freq	Level	Limit	Over	Read	CableAntenna	Preamp	Remark	A/Pos	T/Pos	Pol/Phase
	MHz	dBuV/m	dBuV/m	dB	dBuV	dB	dB/m	dB	cm	deg	
1	5147.97	61.30	74.00	-12.70	20.80	6.49	34.01	0.00 Peak	100	78	VERTICAL
2	5150.00	49.01	54.00	-4.99	8.51	6.49	34.01	0.00 Average	100	78	VERTICAL
3	5205.50	115.73			75.10	6.52	34.11	0.00 Peak	100	78	VERTICAL
4	5206.08	106.60			65.97	6.52	34.11	0.00 Average	100	78	VERTICAL

Item 3, 4 are the fundamental frequency at 5200 MHz.

Channel 48

	Freq	Level	Limit	Over	Read	CableAntenna	Preamp	Remark	A/Pos	T/Pos	Pol/Phase
	MHz	dBuV/m	dBuV/m	dB	dBuV	dB	dB/m	dB	cm	deg	
1	5149.42	54.30	74.00	-19.70	13.80	6.49	34.01	0.00 Peak	100	79	VERTICAL
2	5150.00	43.82	54.00	-10.18	3.32	6.49	34.01	0.00 Average	100	79	VERTICAL
3	5246.08	106.88			66.10	6.56	34.22	0.00 Average	100	79	VERTICAL
4	5246.66	116.14			75.36	6.56	34.22	0.00 Peak	100	79	VERTICAL

Item 3, 4 are the fundamental frequency at 5240 MHz.

Note:

Emission level (dBuV/m) = 20 log Emission level (uV/m)

Corrected Reading: Antenna Factor + Cable Loss + Read Level - Preamp Factor = Level

4.8. Frequency Stability Measurement

4.8.1. Limit

Manufacturers of U-NII devices are responsible for ensuring frequency stability such that an emissions is maintained within the band of operation under all conditions of normal operation as specified in the user's manual or $\pm 20\text{ppm}$ (IEEE 802.11nspecification).

4.8.2. Measuring Instruments and Setting

Please refer to section 5 of equipments list in this report. The following table is the setting of the spectrum analyzer.

Spectrum Parameter	Setting
Attenuation	Auto
Span Frequency	Entire absence of modulation emissions bandwidth
RB	10 kHz
VB	10 kHz
Sweep Time	Auto

4.8.3. Test Procedures

1. The transmitter output (antenna port) was connected to the spectrum analyzer.
2. EUT have transmitted absence of modulation signal and fixed channelize.
3. Set the spectrum analyzer span to view the entire absence of modulation emissions bandwidth.
4. Set RBW = 10 kHz, VBW = 10 kHz with peak detector and maxhold settings.
5. f_c is declaring of channel frequency. Then the frequency error formula is $(f_c - f)/f_c \times 10^6$ ppm and the limit is less than $\pm 20\text{ppm}$ (IEEE 802.11nspecification).
6. The test extreme voltage is to change the primary supply voltage from 85 to 115 percent of the nominal value
7. Extreme temperature rule is $-30^\circ\text{C} \sim 50^\circ\text{C}$.

4.8.4. Test Setup Layout

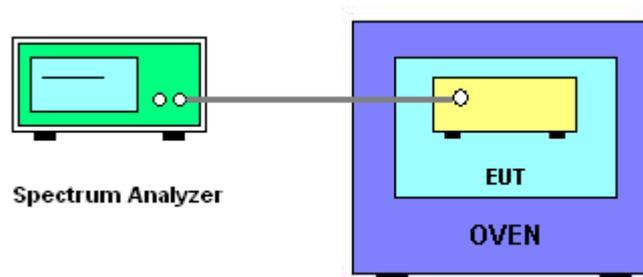

4.8.5. Test Deviation

There is no deviation with the original standard.

4.8.6. EUT Operation during Test

The EUT was programmed to be in continuously un-modulation transmitting mode.

4.8.7. Test Result of Frequency Stability

Voltage vs. Frequency Stability

Voltage	Measurement Frequency (MHz)
(V)	5200
126.50	5199.9832
110.00	5199.9812
93.50	5199.9864
Max. Deviation (MHz)	0.018800
Max. Deviation (ppm)	3.62

Temperature vs. Frequency Stability

Temperature	Measurement Frequency (MHz)
(°C)	5200
-30	5199.9736
-20	5199.9752
-10	5199.9754
0	5199.9788
10	5199.9760
20	5199.9732
30	5199.9722
40	5199.9726
50	5199.9718
Max. Deviation (MHz)	0.028200
Max. Deviation (ppm)	5.42

4.9. Antenna Requirements

4.9.1. Limit

Except for special regulations, the Low-power Radio-frequency Devices must not be equipped with any jacket for installing an antenna with extension cable. An intentional radiator shall be designed to ensure that no antenna other than that furnished by the responsible party shall be used with the device. The use of a permanently attached antenna or of an antenna that uses a unique coupling to the intentional radiator shall be considered sufficient to comply with the provisions of this Section. The manufacturer may design the unit so that the user can replace a broken antenna, but the use of a standard antenna jack or electrical connector is prohibited. Further, this requirement does not apply to intentional radiators that must be professionally installed.

4.9.2. Antenna Connector Construction

Please refer to section 3.3 in this test report; antenna connector complied with the requirements.

5. LIST OF MEASURING EQUIPMENTS

Instrument	Manufacturer	Model No.	Serial No.	Characteristics	Calibration Date	Remark
EMI Test Receiver	R&S	ESCS 30	100377	9kHz - 2.75GHz	Oct. 23, 2012	Conduction (CO01-CB)
LISN	F.C.C.	FCC-LISN-50-16-2	04083	150kHz - 100MHz	Nov. 26, 2012	Conduction (CO01-CB)
V- LISN	Schwarzbeck	NSLK 8127	8127-478	9kHz - 30MHz	Jun. 22, 2012	Conduction (CO01-CB)
COND Cable	Woken	Cable	01	0.15MHz-30MHz	Dec. 4, 2012	Conduction (CO01-CB)
Software	Audix	E3	5.410e	-----	-----	Conduction (CO01-CB)
Signal analyzer	R&S	FSV40	100979	9KHz-40GHz	Oct. 08, 2012	Conducted (TH01-CB)
Temp. and Humidity Chamber	Ten Billion	TTH-D3SP	TBN-931011	-30~100 degree	Jun. 05, 2012	Conducted (TH01-CB)
Signal Generator	R&S	SMR40	100302	10MHz-40GHz	Nov. 27, 2012	Conducted (TH01-CB)
RF Power Divider	Woken	2 Way	0120A02056002D	2GHz - 18GHz	Nov. 18, 2012	Conducted (TH01-CB)
RF Power Divider	Woken	3 Way	MDC2366	2GHz - 18GHz	Nov. 18, 2012	Conducted (TH01-CB)
RF Power Divider	Woken	4 Way	0120A04056002D	2GHz - 18GHz	Nov. 18, 2012	Conducted (TH01-CB)
RF Cable-high	Woken	High Cable-7	-	1 GHz - 26.5 GHz	Nov. 19, 2012	Conducted (TH01-CB)
RF Cable-high	Woken	High Cable-8	-	1 GHz - 26.5 GHz	Nov. 19, 2012	Conducted (TH01-CB)
RF Cable-high	Woken	High Cable-9	-	1 GHz - 26.5 GHz	Nov. 19, 2012	Conducted (TH01-CB)
RF Cable-high	Woken	High Cable-10	-	1 GHz - 26.5 GHz	Nov. 19, 2012	Conducted (TH01-CB)
RF Cable-high	Woken	High Cable-11	-	1 GHz - 26.5 GHz	Nov. 19, 2012	Conducted (TH01-CB)
Power Sensor	Anritsu	MA2411B	0917223	300MHz-40GHz	Nov. 28, 2012	Conducted (TH01-CB)
Power Meter	Anritsu	ML2495A	1035008	300MHz-40GHz	Nov. 27, 2012	Conducted (TH01-CB)
BILOG ANTENNA	Schaffner	CBL6112D	22021	20MHz - 2GHz	Jan. 11, 2012	Radiation (03CH01-CB)
Horn Antenna	EMCO	3115	00075790	750MHz-18GHz	Nov. 27, 2012	Radiation (03CH01-CB)
Horn Antenna	SCHWARZBEAK	BBHA 9170	BBHA9170252	15GHz - 40GHz	Nov. 23, 2012	Radiation (03CH01-CB)
Pre-Amplifier	Agilent	8447D	2944A10991	0.1MHz - 1.3GHz	Nov. 27, 2012	Radiation (03CH01-CB)
Pre-Amplifier	Agilent	8449B	3008A02310	1GHz - 26.5GHz	Nov. 23, 2012	Radiation (03CH01-CB)
Pre-Amplifier	WM	TF-130N-R1	923365	26.5GHz - 40GHz	Jul. 31, 2012	Radiation (03CH01-CB)
Spectrum analyzer	R&S	FSP40	100056	9KHz-40GHz	Nov. 16, 2012	Radiation (03CH01-CB)

Instrument	Manufacturer	Model No.	Serial No.	Characteristics	Calibration Date	Remark
EMI Test Receiver	R&S	ESCS 30	100355	9KHz ~ 2.75GHz	Mar. 20, 2012	Radiation (03CH01-CB)
Turn Table	INN CO	CO 2000	N/A	0 ~ 360 degree	N.C.R	Radiation (03CH01-CB)
Antenna Mast	INN CO	CO2000	N/A	1 m - 4 m	N.C.R	Radiation (03CH01-CB)
RF Cable-low	Woken	Low Cable-1	N/A	30 MHz - 1 GHz	Nov. 18, 2012	Radiation (03CH01-CB)
RF Cable-high	Woken	High Cable-1	N/A	1 GHz – 26.5 GHz	Nov. 18, 2012	Radiation (03CH01-CB)
RF Cable-high	Woken	High Cable-2	N/A	1 GHz – 26.5 GHz	Nov. 18, 2012	Radiation (03CH01-CB)
RF Cable-high	Woken	High Cable-3	N/A	1 GHz - 40 GHz	Nov. 18, 2012	Radiation (03CH01-CB)
RF Cable-high	Woken	High Cable-4	N/A	1 GHz - 40 GHz	Nov. 18, 2012	Radiation (03CH01-CB)

Note: Calibration Interval of instruments listed above is one year.

“*” Calibration Interval of instruments listed above is two years.

NCR means Non-Calibration required.

6. TEST LOCATION

SHIJR	ADD : 6Fl., No. 106, Sec. 1, Shintai 5th Rd., Shijr City, Taipei, Taiwan 221, R.O.C. TEL : 886-2-2696-2468 FAX : 886-2-2696-2255
HWA YA	ADD : No. 52, Hwa Ya 1st Rd., Kwei-Shan Hsiang, Tao Yuan Hsien, Taiwan, R.O.C. TEL : 886-3-327-3456 FAX : 886-3-318-0055
LINKOU	ADD : No. 30-2, Dingfu Tsuen, Linkou Shiang, Taipei, Taiwan 244, R.O.C TEL : 886-2-2601-1640 FAX : 886-2-2601-1695
DUNGHU	ADD : No. 3, Lane 238, Kangle St., Neihu Chiu, Taipei, Taiwan 114, R.O.C. TEL : 886-2-2631-4739 FAX : 886-2-2631-9740
JUNGHE	ADD : 7Fl., No. 758, Jungjeng Rd., Junghe City, Taipei, Taiwan 235, R.O.C. TEL : 886-2-8227-2020 FAX : 886-2-8227-2626
NEIHU	ADD : 4Fl., No. 339, Hsin Hu 2 nd Rd., Taipei 114, Taiwan, R.O.C. TEL : 886-2-2794-8886 FAX : 886-2-2794-9777
JHUBEI	ADD : No.8, Lane 724, Bo-ai St., Jhubei City, HsinChu County 302, Taiwan, R.O.C. TEL : 886-3-656-9065 FAX : 886-3-656-9085

7. TAF CERTIFICATE OF ACCREDITATION



Certificate No. : L1190-110702

財團法人全國認證基金會
Taiwan Accreditation Foundation

Certificate of Accreditation

This is to certify that

Sporton International Inc.
EMC & Wireless Communications Laboratory
No.52, Hwa Ya 1st Road, Hwa Ya Technology Park, Kwei-Shan Hsiang, Tao Yuan Hsien,
Taiwan, R.O.C.

is accredited in respect of laboratory

Accreditation Criteria	: ISO/IEC 17025:2005
Accreditation Number	: 1190
Originally Accredited	: December 15, 2003
Effective Period	: January 10, 2010 to January 09, 2013
Accredited Scope	: Testing Field, see described in the Appendix
Specific Accreditation Program	: Accreditation Program for Designated Testing Laboratory for Commodities Inspection Accreditation Program for Telecommunication Equipment Testing Laboratory Accreditation Program for BSMI Mutual Recognition Arrangement with Foreign Authorities

Jay-San Chen
President, Taiwan Accreditation Foundation
Date : July 02, 2011

P1, total 22 pages

The Appendix forms an integral part of this Certificate, which shall be invalid when use without the Appendix