



keonn

Modular RFID
Components

Advantenna-p16™

RFID UHF fan beam antenna

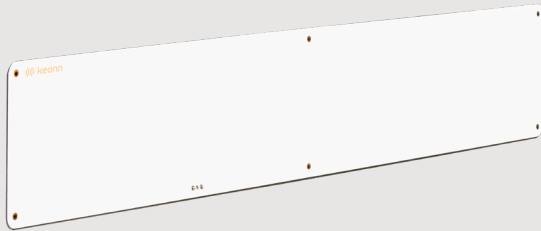



Benefits:

- Slightly narrow beam in the long edge
- Wide beam in the short edge
- High gain
- Very thin form factor
- Cost effective

Applications:

- Time keeping of sport events (marathons, etc.)
- Race timing
- Overhead loss prevention systems
- Portals
- Doors and corridors
- Toll systems
- Vehicle tracking

Product overview

Advantenna-p16 is a compact RFID UHF 6 elements patch antenna with circular polarization and a radiation pattern characterized by a 20° beam width in the direction of the antenna long edge and 90° in the direction of the antenna short edge. This radiation pattern makes this antenna ideal for many RFID applications such as:

- Time keeping of sport events, marathons, race timing
- Overhead loss prevention systems
- Portals
- Corridors
- Doors
- Toll systems
- Vehicle tracking

Holder available specially designed for this model of antenna: [AdvanHolder-p16](#)

Connector options

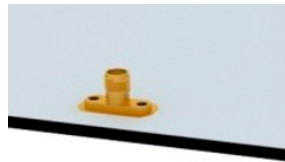

Flange straight

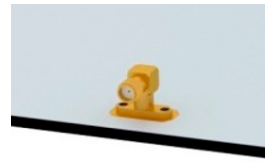

Flange right angle

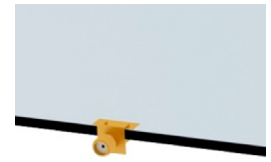

Edge mount

Flange right angle connector with rotation

Default

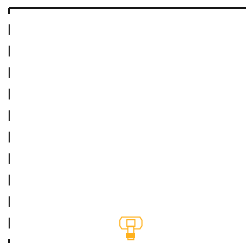

90 degrees

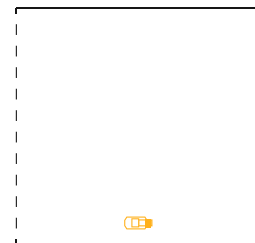

180 degrees

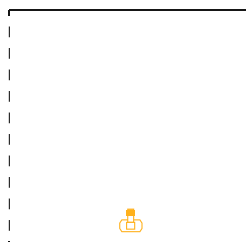

270 degrees

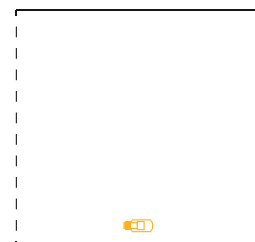

Antenna radiation pattern

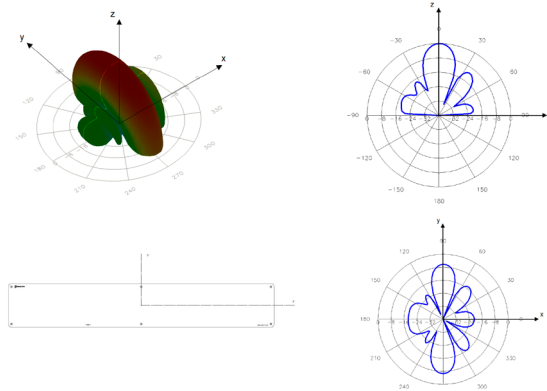

*Front-to-back ratio not drawn

Technical specifications

Operating Frequency EU Version	865 - 868 MHz (ETSI EN 302 208)
Operating Frequency US Version	902 - 928 MHz (FCC part 15)
Antenna Technology	Patch
Radiation pattern	Fan beam
Gain	EU version 9.4 dBiC (Typical), 9.5 dBiC (Max) 6.8 dBiL* US version 9.2 dBiC (Typical), 9.4 dBiC (Max) 6.8 dBiL*
VSWR	< 1.4:1
Beam width (AZ / EL)	20° / 90°
Sidelobe level	< -15 dB
Front-to-Back Ratio	< -20 dB
Polarization	Circular - LHCP (Left Hand Circular Polarization)
Axial Ratio	EU version* At Boresight 0.6 dB At 3dB Beamwidth 0.5 dB (Typical), 2.5 dB (Max) US version* At Boresight 0.6 dB At 3dB Beamwidth 1.0 dB (Typical), 2.8 dB (Max)
Input Impedance	50 Ω
Connector	SMA or MCX Flange, flange right angle, or edge mount (on the long side of the antenna)
Regulation	ROHS - EU Directive 2015/863 WEEE - EU Directive 2012/19/EU REACH - EC No 1907/2006 ETSI EN 302 208
IP rating	Indoor antenna IP68**
Temperature range	-20°C to +80°C
Size excluding connector	837 mm x 137 mm x 3.3 mm 32.9 inches x 5.4 inches x 0.13 inches
Size with edge mount connector	837 mm x 137 mm x 9 mm 32.9 inches x 5.4 inches x 0.4 inches
Size with flange straight angle connector	837 mm x 137 mm x 13 mm 32.9 inches x 5.4 inches x 0.5 inches
Size with flange right angle connector	837 mm x 137 mm x 16.31 mm 32.9 inches x 5.4 inches x 0.6 inches
Antenna weight	725 g

*Measured at the center of the band

** IP rating in this case indicates the conditions that the antenna can withstand at specific times and, afterwards, continue working normally, they are not conditions under which it can work permanently.

Mechanical specifications

With flange straight angle connector

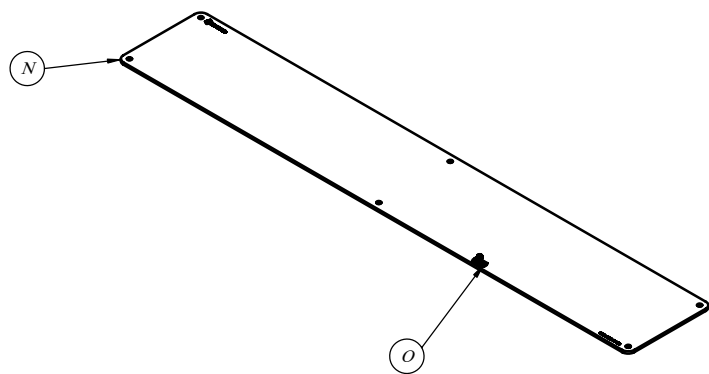
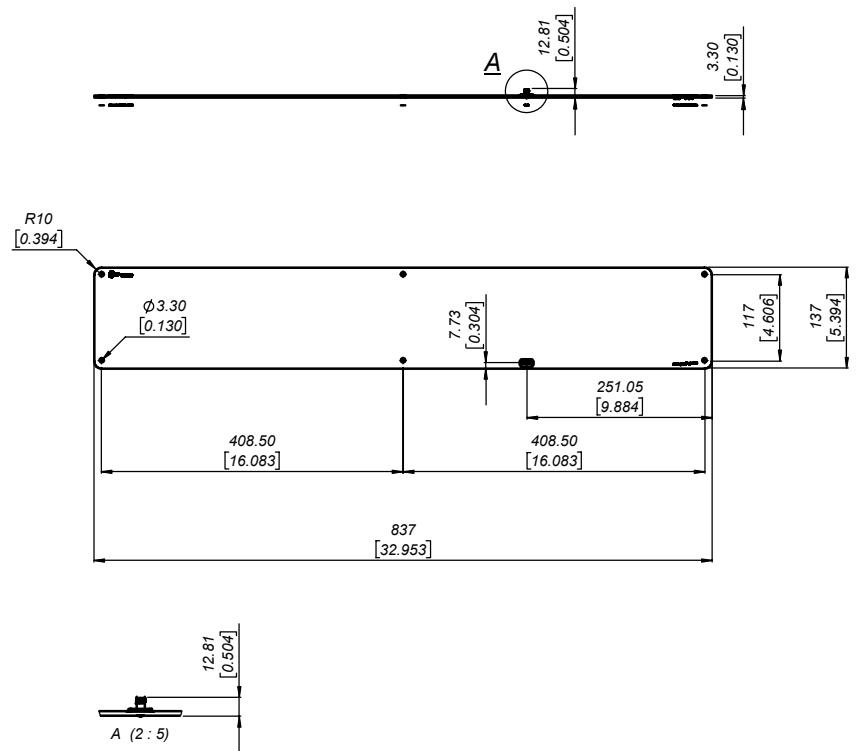

Units in millimeters and [inches]

Mechanical specifications

With flange right angle connector

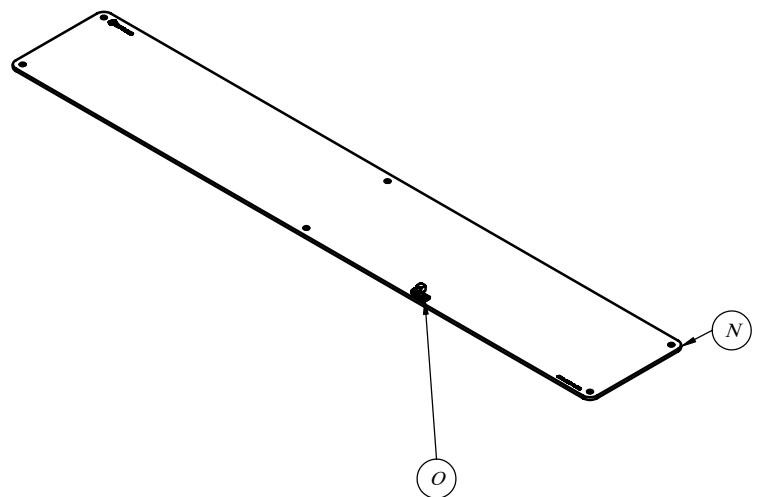
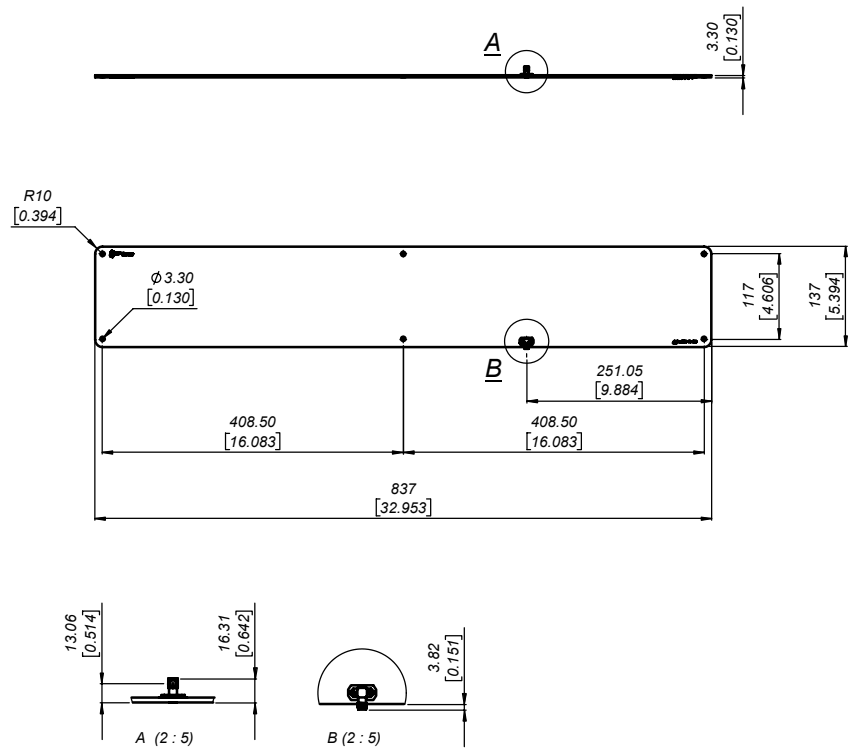

Units in millimeters and [inches]

Mechanical specifications

With edge mount connector

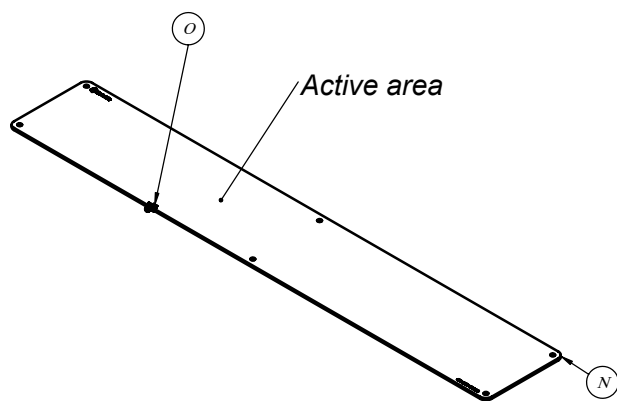
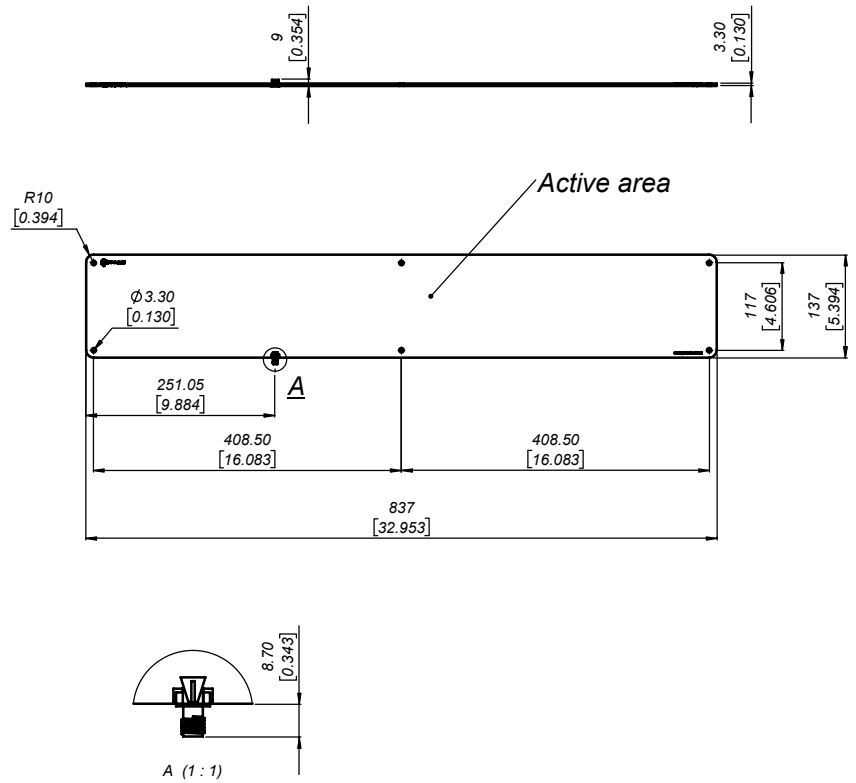

Units in millimeters and [inches]

Product codes for ordering

ADAN-p16	FF	-	CS	COR	CT	-	mmm	
								FF = frequency band
	EU							865,6 MHz - 867,6 MHz
	US							902,0 MHz - 928,0 MHz
								Connector shape
			EL					Edge mount, at the long side of the antenna
			FL					Flange straight
			FR					Flange right angle
								Connector orientation (only for right angle SMA connector)
								Default orientation
				90				Rotated 90° counterclockwise
				180				Rotated 180° counterclockwise
				270				Rotated 270° counterclockwise
								Connector type
					SMA			SMA connector
					MCX			MCX connector (only available in edge mount and flange straight)
								Model
							200	Model number

Examples:

ADAN-p16EU-ELSMA-200:

- Advantenna-p16
- Frequency band : 865,6 MHz - 867,6 MHz
- **Edge mount** connector, placed at the long side of the antenna
- **SMA** connector
- Model **200**

ADAN-p16US-FRSMA-200:

- Advantenna-p16
- Frequency band : 902,0 MHz - 928,0 MHz
- **Flange right angle** connector
- Default connector orientation
- **SMA** connector
- Model **200**

ADAN-p16EU-FR270SMA-200:

- Advantenna-p16
- Frequency band : 865,6 MHz - 867,6 MHz
- **Flange right angle** connector
- Connector rotated 270° counterclockwise
- **SMA** connector
- Model **200**

Disposal of the product

Do not dispose the product in municipal or household waste. Please check your local regulations for disposal/recycle of electronic products.





Copyright © Keonn Technologies S.L.
All rights reserved.

Information in this publication
supersedes all earlier versions.
Specifications subject to change
without notice.





keonn

Modular RFID
Components

AdvanSplitter-2™ RFID UHF power splitter





Benefits:

- Combines different Keonn antennas, creating new antennas with longer read range and narrower beamwidth
- Very fast and easy connection
- Very low insertion loss
- Capable of supporting unbalanced loads

Applications:

- Any RFID application that requires long read ranges
- Any RFID application that requires narrow beamwidths

Product overview

AdvanSplitter-2 is a high performance two port power splitter designed for RFID UHF applications.

AdvanSplitter-2 can combine different Keonn antennas in new ways, creating new antennas with longer read range and narrower beamwidth.

Some examples of antenna combinations are the following:

- Two Advantenna-p11 can be connected to AdvanSplitter to create an antenna array of 1 x 2 elements
- Two Advantenna-p13 (antenna array of 1 x 3 elements) can be connected to AdvanSplitter to create an antenna array of 1 x 6 elements

AdvanSplitter-2 can therefore be used to create new antennas adapted to the needs of each RFID application. This flexibility allows to find the optimal antenna solution for any RFID project.

AdvanSplitter-2 can also be used in systems where reading speed is critical and tag location is not determinant.

AdvanSplitter-2 has very low insertion loss, typically 0.4 dB above the 3 dB split.

AdvanSplitter-2 has been designed to keep its performance even when one port is not connected to any antenna.

Technical specifications

Operating frequency	860 MHz to 950 MHz
Number of ports	2
Amplitude unbalance	0.3 dB
Insertion loss (above 3 dB)	0.6 dB (typ.), 0.8 dB (max.)
Input return loss	24.0 dB typical, 22.5 dB minimum
Output return loss	22.0 dB typical, 21.0 dB minimum
Maximum input power isolation	33.0 dB typical, 23.5 dB minimum
Phase unbalance	< 1°
Amplitude unbalance	0.3 dB
Maximum input power	33 dBm
RF connectors	1 input and 2 output SMA 50 ohm female connectors
Weight with enclosure	107 gr (3.8 oz)
Weight without enclosure	28 g (1.0 oz)
Size with enclosure	92 mm x 73 mm x 26 mm (3.6 in x 2.9 in x 1 in)
Size without enclosure	92 mm x 67 mm x 14 mm (3.6 in x 2.6 in x 0.6 in)
Operating temperature	-40 °C to 55 °C
Storage temperature	-40 °C to 85 °C
EU Directives	RoHS compliant (2002/95/EC), EMC (2004/108/EC)

Mechanical specifications

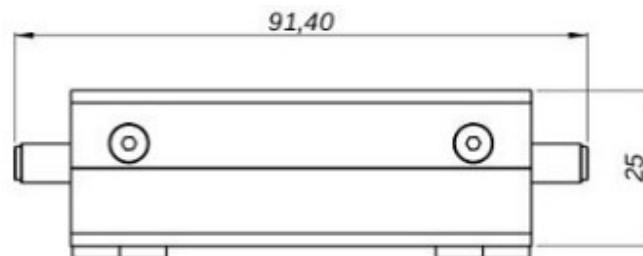
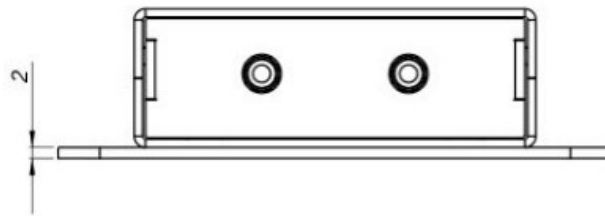
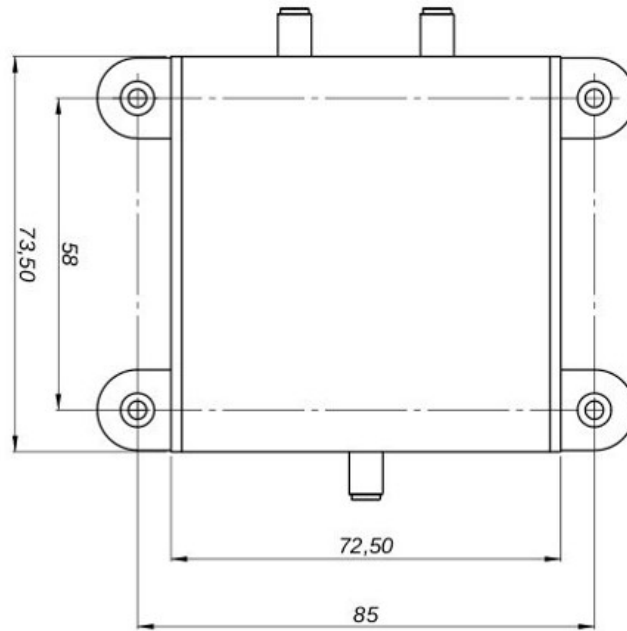

Units in millimeters and [inches]

Product codes for ordering

ADSP	-	NP	-	F	CT	-	mmm	
								NP = Number of Ports
		2						2 ports
		4						4 ports
		8						8 ports
								F = Frame
				e				Enclosure (only for model with 2 and 4 ports)
								no enclosure
								CT = connector type
					SMA			SMA Straight PCB mount
					MCX			MCX connector (only available in edge mount and flange straight)
								mmm = Model
							110	Model number

Examples:

ADSP-2-eSMA-110:

- AdvanSplitter
- 2 ports
- with enclosure
- SMA connector type
- Model 110

ADSP-2-SMA-110:

- AdvanSplitter
- 2 ports
- without enclosure
- SMA connector type
- Model 110



Copyright © Keonn Technologies S.L.
All rights reserved.

Information in this publication
supersedes all earlier versions.
Specifications subject to change
without notice.



3. Summary

- The performance of antennas is shown in table

Ant16 (1x6 array)	Spec.	INPAQ
Size (mm)	<137X837	145x839
Thickness (mm)	3-12	3
Axial Ratio (dB)	<3	1.09~15.69 (AR<3 · F=913~918MHz)
Gain (dBi)	9~10	9.15~9.85
Azimuth 3dB Beam width (deg)	20, +/- 5	27~31
Elevation 3dB Beam width (deg)	90, +/- 10	90~93
Side lobe Rejection(dB)	>15	8.8~12.82
Front to back ratio (dB)	>20	9.1~11.41

3. Summary

- The performance of antennas is shown in table

Ant12 (30deg tilted 1x2 array)	Spec.	INPAQ
Size (mm)	<152.4X304.8	150X300
Thickness (mm)	3-12	8
Axial Ratio (dB)	<3	0.54~10.23 (AR<3 · F=913~920MHz)
Gain (dBi)	5~6	6.61~7.51
Azimuth 3dB Beam width (deg)	60, +/- 10	53~56
Elevation 3dB Beam width (deg)	90, +/- 10	83~90
Azimuth Steering angle (deg))_YZ Plane	30	19~23
Side lobe Rejection(dB)_YZ Plane	>15	7.74~11.59
Front to back ratio (dB)_YZ Plane	>20	14.06~16.64

3. Summary

PO Sample 1

- The performance of antennas is shown in table

Ant33 (3x3 array)	Spec.	INPAQ
Size (mm)	<457.2X457.2	427X427
Thickness (mm)	3-12	3
Axial Ratio (dB)	<3	0.31~13.69(AR<3 · F=907~912 MHz)
Gain (dBi)	10~12	11.39~12.41
Azimuth 3dB Beam width (deg)	35, +/- 10	39~44
Elevation 3dB Beam width (deg)	35, +/- 10	39~41
Side lobe Rejection(dB)	>15	11.59~12.48
Front to back ratio (dB)	>20	25.58~29.77

3. Summary

- The performance of antennas is shown in table

Ant16 (1x6 array)	Spec.	INPAQ
Size (mm)	<137X837	145x839
Thickness (mm)	3-12	3
Axial Ratio (dB)	<3	1.09~15.69 (AR<3 · F=913~918MHz)
Gain (dBi)	9~10	9.15~9.85
Azimuth 3dB Beam width (deg)	20, +/- 5	27~31
Elevation 3dB Beam width (deg)	90, +/- 10	90~93
Side lobe Rejection(dB)	>15	8.8~12.82
Front to back ratio (dB)	>20	9.1~11.41



keonn

Modular RFID
Components

AdvanSplitter-2™ RFID UHF power splitter





Benefits:

- Combines different Keonn antennas, creating new antennas with longer read range and narrower beamwidth
- Very fast and easy connection
- Very low insertion loss
- Capable of supporting unbalanced loads

Applications:

- Any RFID application that requires long read ranges
- Any RFID application that requires narrow beamwidths

Product overview

AdvanSplitter-2 is a high performance two port power splitter designed for RFID UHF applications.

AdvanSplitter-2 can combine different Keonn antennas in new ways, creating new antennas with longer read range and narrower beamwidth.

Some examples of antenna combinations are the following:

- Two Advantenna-p11 can be connected to AdvanSplitter to create an antenna array of 1 x 2 elements
- Two Advantenna-p13 (antenna array of 1 x 3 elements) can be connected to AdvanSplitter to create an antenna array of 1 x 6 elements

AdvanSplitter-2 can therefore be used to create new antennas adapted to the needs of each RFID application. This flexibility allows to find the optimal antenna solution for any RFID project.

AdvanSplitter-2 can also be used in systems where reading speed is critical and tag location is not determinant.

AdvanSplitter-2 has very low insertion loss, typically 0.4 dB above the 3 dB split.

AdvanSplitter-2 has been designed to keep its performance even when one port is not connected to any antenna.

Technical specifications

Operating frequency	860 MHz to 950 MHz
Number of ports	2
Amplitude unbalance	0.3 dB
Insertion loss (above 3 dB)	0.6 dB (typ.), 0.8 dB (max.)
Input return loss	24.0 dB typical, 22.5 dB minimum
Output return loss	22.0 dB typical, 21.0 dB minimum
Maximum input power isolation	33.0 dB typical, 23.5 dB minimum
Phase unbalance	< 1°
Amplitude unbalance	0.3 dB
Maximum input power	33 dBm
RF connectors	1 input and 2 output SMA 50 ohm female connectors
Weight with enclosure	107 gr (3.8 oz)
Weight without enclosure	28 g (1.0 oz)
Size with enclosure	92 mm x 73 mm x 26 mm (3.6 in x 2.9 in x 1 in)
Size without enclosure	92 mm x 67 mm x 14 mm (3.6 in x 2.6 in x 0.6 in)
Operating temperature	-40 °C to 55 °C
Storage temperature	-40 °C to 85 °C
EU Directives	RoHS compliant (2002/95/EC), EMC (2004/108/EC)

Mechanical specifications

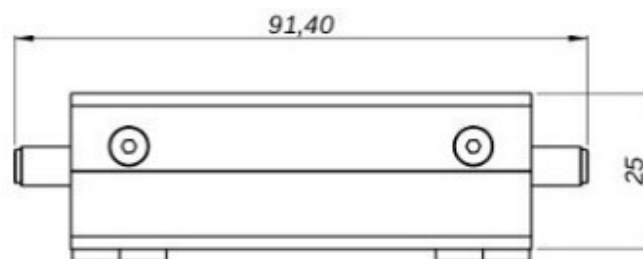
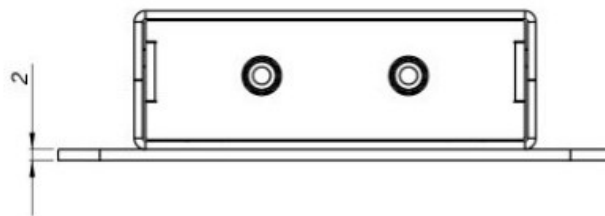
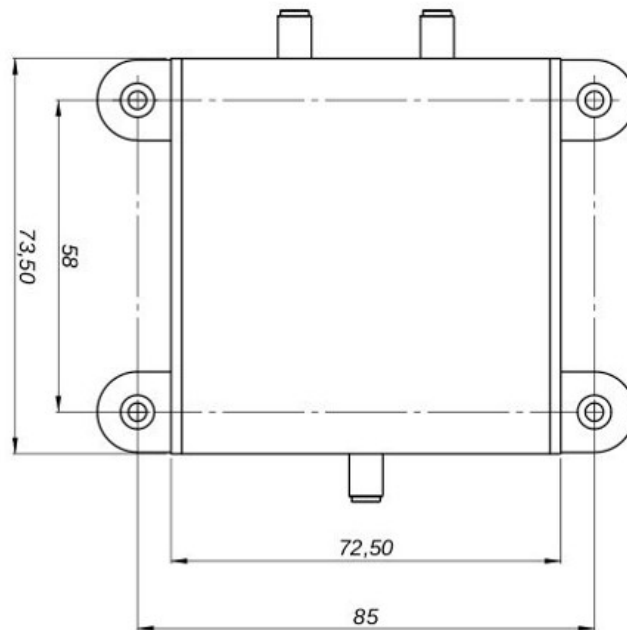

Units in millimeters and [inches]

Product codes for ordering

ADSP	-	NP	-	F	CT	-	mmm	
								NP = Number of Ports
		2						2 ports
		4						4 ports
		8						8 ports
								F = Frame
				e				Enclosure (only for model with 2 and 4 ports)
								no enclosure
								CT = connector type
					SMA			SMA Straight PCB mount
					MCX			MCX connector (only available in edge mount and flange straight)
								mmm = Model
							110	Model number

Examples:

ADSP-2-eSMA-110:

- AdvanSplitter
- 2 ports
- with enclosure
- SMA connector type
- Model 110

ADSP-2-SMA-110:

- AdvanSplitter
- 2 ports
- without enclosure
- SMA connector type
- Model 110



Copyright © Keonn Technologies S.L.
All rights reserved.

Information in this publication
supersedes all earlier versions.
Specifications subject to change
without notice.



ABOUT TIMES-7

We are a high-tech company specializing in the design and manufacture of RAIN (UHF) RFID antennas. Founded in 2006, Times-7 has developed the largest portfolio of fixed RAIN RFID reader antennas. Based in Lower Hutt, New Zealand we export all over the world through an authorized network.

Times-7 antennas are famous for their quality and performance.

In addition to our world-class products and in-depth expertise, our customers appreciate Times-7's customer service and technical support.

We are responsive in supporting a large global customer base and ensuring the success of our customer's implementations.

Times-7 Research Ltd
10 Te Puni Street
Lower Hutt 5012
New Zealand

NEW ZEALAND
P: +64 4 974 6566

USA/CANADA
P: +1 408 769 5025

E: sales@times-7.com

www.times-7.com



The A6590C Ground Antenna

Ultra-low profile circularly polarised UHF ground antenna

Just 8 mm / 0.3 in. thick

Powerful 9 dBic gain

Typical applications:
Conference attendee & people tracking, retail marketing, race & event timing

Part of Times-7's exclusively unique range of ground antennas the A6590C is optimized for RFID deployments involving moving products, assets and people. From conference attendee & people tracking, retail presence aware / loyalty marketing & race timing, the A6590C is ideal for applications where traditional side antennas are unsuitable or not optimized for the application. At just 8 mm / 0.3 in. thick, the durable, high performance A6590C is uniquely capable of lying flat on the ground within a doorway sized footprint.

Order Information

Ordering Information (please quote product code, band / cable type & part no.)

*Antenna Product Code	Band	Part No.
A6590C	ETSI 865-868 MHz	71324
A6590C	FCC 902-928 MHz	71325
Cable Accessories Product Code	Cable Type	Part No.
Cable 2 m, SMA to RPTNC	T7 195 / 240 / 400	71436 / 71782 / 72042
Cable 4 m, SMA to RPTNC	T7 240 / 400	71784 / 72043
Cable 6 m, SMA to RPTNC	T7 240 / 400	71904 / 72044
Cable 8 m, SMA to RPTNC	T7 240 / 400	71788 / 72045

*Built in New Zealand. ROHS & CE compliant.

View the Times-7 Cable Accessory datasheet [here](#)

Specifications

Physical / Environmental Specifications

Dimensions	915 mm x 305 mm x 8 mm
Length (x) x Width (y) x Depth (z)	36.02" x 12.00" x 0.31"
Boxed unit dimensions:	935 mm x 315 mm x 25mm 36.81" x 12.40" x 0.98"
Weight:	Net: 2.4 kg / 5.29 lbs. Gross: 2.8 kg / 6.17 lbs.
Radome Material:	Fire retardant ABS
Environmental Rating:	IP65
Operating / Storage Temperature:	-20° to +55°C / -30° to +65°C -4° to +131°F / -22° to +149°F
Connector type / position:	SMA female side fly lead (300 mm / 1 ft.) or 6ft / 2m cable to RP-TNC Plug

Electrical Specifications

Frequency Range:	865-868 MHz / 902-928 MHz
Polarization:	RHCP (Right Hand Circular Polarised)
Far-field Gain:	9 dBiC typical
Far-field 3 dB beamwidth: *	20° in xz-plane, 80° in yz-plane
VSWR	1.4 typical
Front to back ratio:	24 dB
Axial Ratio:	2 dB typical
Nominal impedance:	50 Ω
Anti-static protection:	Yes, DC grounded
Antenna detection	10 K Ω resistance
Maximum Input Power:	3 W

Radiation Patterns

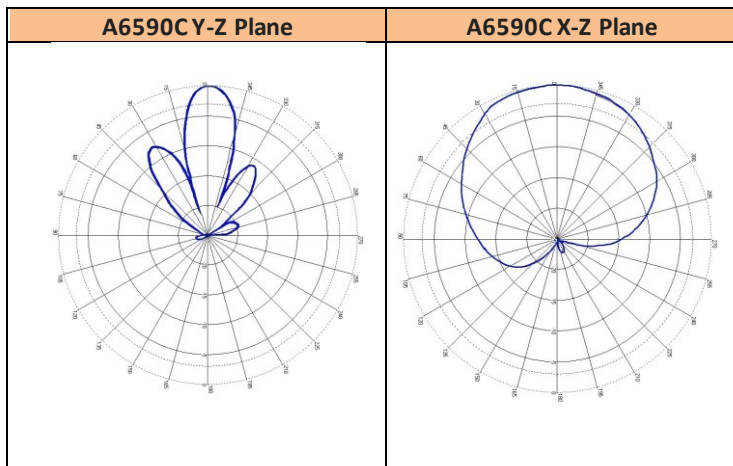

Azimuth Planes



Installation Instructions

- Ensure that only finger tightness is used for the SMA connector. Use of tools to tighten the connector will apply excessive force and will damage the connector.
- Avoid any load or bending force from the cable on the connector.

Payload Information

This ground antenna is designed to support moderate loads, such as hand trolleys and carts with rubber wheels, runners, bicyclists, and occasional vehicular traffic with pneumatic tires, etc. Care must be taken to ensure the antenna is installed on a smooth, hard, flat surface. Ensure that the antenna surface is not damaged from sharp objects such as steel-edged wheels, stone chips or glass fragments, etc. Any point load must not exceed 100 psi (7 kg/ cm²) and the maximum distributed load on the mat should not exceed 1100lb (500kg).

Applications

Conference Attendee / People Tracking

Tracking attendees at conferences, trade shows, and other business events using the A6590C antenna can be a great way to obtain valuable data. The A6090C is a high performance UHF RFID ground antenna, perfect for people tracking applications.



Race & Event Timing

The A6090C RFID antenna is suitable for use in a variety of indoor and outdoor environments that require an ultra-low profile, high-performance antenna that can be concealed under a mat or other covering. Perfect for tracking race times at sporting events.



OUR GLOBAL NETWORK

In addition to our world-class products and in-depth expertise, Times-7 is known for their quality of customer service and technical support. We place emphasis on our responsiveness in supporting a large global customer base and ensuring the success of our customer's implementations.

Times-7 Research Ltd
10 Te Puni Street
Lower Hutt 5012

New Zealand
NEW ZEALAND
P: +64 4 974 6566

USA/CANADA
P: +1 408 769 5025

E: sales@times-7.com

www.times-7.com

The technical data contained in this publication is not a guarantee for which Times-7 Research Ltd assumes legal accountability. It is indicative of typical performance, and if required should be relied on for specific applications only after due verification.

All technical data, specifications and other information contained herein are deemed to be the proprietary intellectual property of Times-7 Research Ltd. No reproduction, copy or use thereof may be made without the express written consent of Times-7 Research Ltd.

Times-7, and the stylized T-7 Antennas logo are trademarks or registered trademarks of Times-7 Research Ltd. All other trademarks are the property of their respective owners.

© 2022 Times-7 Research Ltd. All rights reserved. Specifications are subject to change without notice. Datasheet v2.0

Mechanical Drawing for the A6590C

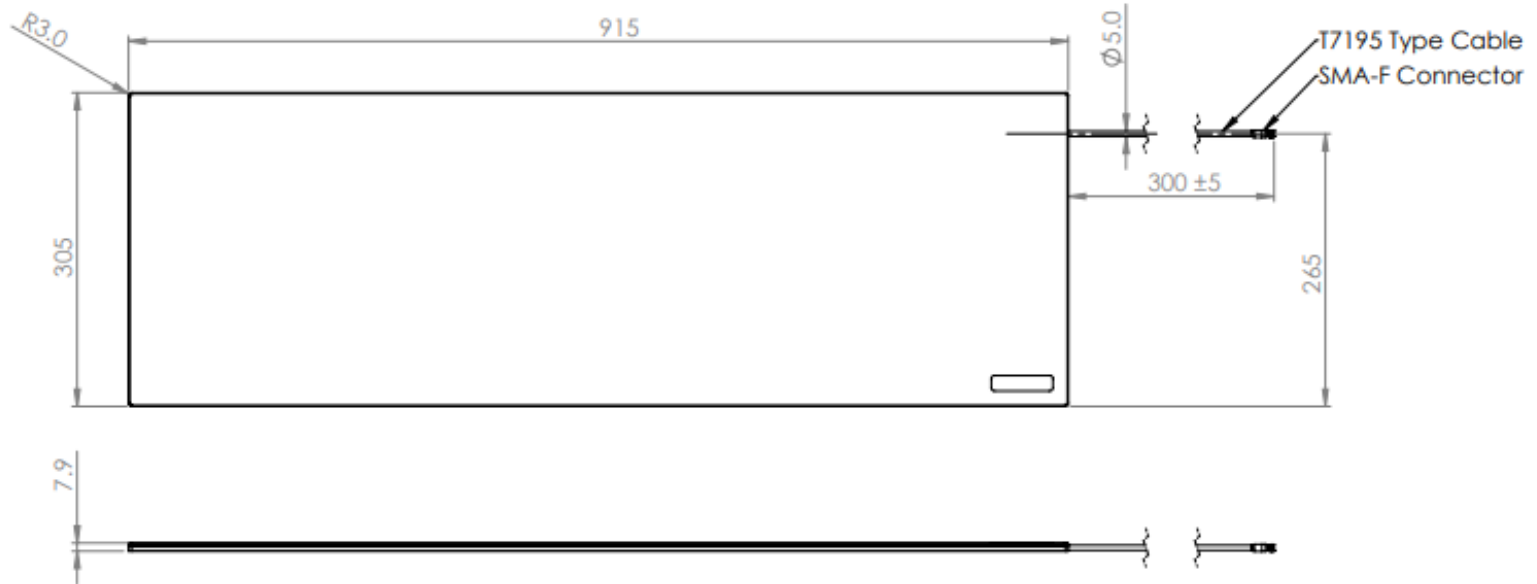

THE INFORMATION CONTAINED IN THIS DRAWING IS THE SOLE PROPERTY OF TIMES-7 LTD. ANY REPRODUCTION IN PART OR AS A WHOLE WITHOUT THE WRITTEN PERMISSION OF TIMES-7 IS PROHIBITED.		DIMENSIONS ARE IN mm UNLESS OTHERWISE SPECIFIED TOLERANCES: NO DECIMAL PLACES ± 1 ONE PLACE DECIMAL ± 0.5				DESCRIPTION <p style="text-align: center;">A6590C Antenna</p>	
DRAWN C Wilson	SIGNATURE 	DATE 27/05/2019	SIZE A3	PART NO. 71324 (ETSI) , 71325 (FCC)	REV B	DO NOT SCALE DRAWING	
APPROVED R Lopez	SIGNATURE 	DATE 11/06/2019	SHEET 1 OF 1				



[Homepage](#) > [Products](#) > [RFID Antennas](#) > [902-928 MHz Reader Antennas](#) > **Circular Antennas**

CIRCULAR ANTENNAS

MT-263020/TRH/A
902-928 MHZ, 11 DBIC RHCP READER ANTENNA



ELECTRICAL

REGULATORY COMPLIANCE	RoHS, CE 0682
FREQUENCY RANGE	902 - 928 MHz
GAIN	11 dBic (min)
VSWR	1.5 : 1 (max) 1.3 : 1 (typ)
POLARIZATION	RHCP
3dB ELEVATION BEAMWIDTH	63° (typ)
3dB AZIMUTH BEAMWIDTH	30° (typ)
SIDELOBES LEVEL	-12 dB (max) -15 dB (typ)
F/B RATIO	-20 dB (max)
POWER	6W (max)
INPUT IMPEDANCE	50 (ohm)
LIGHTNING PROTECTION	DC Grounded

MECHANICAL

DIMENSIONS (LxWxD)	630x320x32
CONNECTOR	TNC-Reverse Polarity
WEIGHT	2.8 kg (max)
MOUNTING KIT	See RD41181900C , MT-120019
RADOME MATERIAL	Plastic UV Resistant per ETSI 300
OUTLINE DRAWING	RD41895600C
ORIENTATION	Rectangular

[ADD TO COMPARE PAGE](#) [TO COMPARE PAGE](#)

ENVIRONMENTAL

TEST	STANDARD	DURATION	TEMPERTURE	NOTES
LOW TEMPERATURE	IEC 68-2-1	72 h	-55°C	
HIGH TEMPERATURE	IEC 68-2-2	72 h	+71°C	
TEMP. CYCLING	IEC 68-2-14	1 h	-45°C +70°C	3 Cycles
THERMAL SHOCK NONO-OPERATING			-30°C to+70°C	Ramp 30°C/min
HUMIDITY	ETSI EN300-2-4 T4.1E	144 h		95%
WATER TIGHTNESS	IEC 529			IP54
DUST RESISTANCE				IP54
SOLAR RADIATION	ASTM G53	1000h		
OZONE RESISTANCE	ETSI 300			
FLAMMABILITY	UL 94			Class HB
QUASI RANDOM VIBRATION				20g rms for 4 hours
VEHICLE VIBRATION OPERATING	1 grms, 10-500 Hz, in 3 axis			6 hours total, 2 hr in each axis. Accelerated wear – an additional 50hrs in worst case axis.
MECHANICAL SHOCK OPERATING	10g, 11msec, half sine pulse			

**AZIMUTH RADIATION PATTERN MIDBAND
FREQ. 0.915 GHZ**

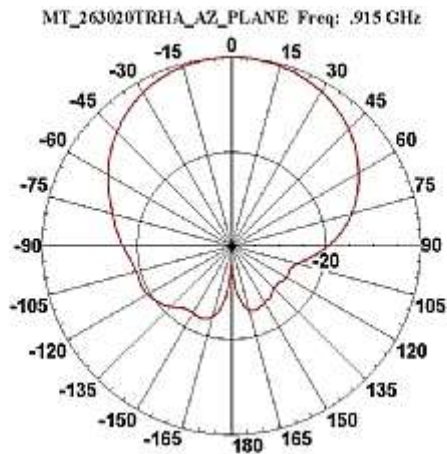

**ELEVATION RADIATION PATTERN MIDBAND
FREQ. 0.915 GHZ**

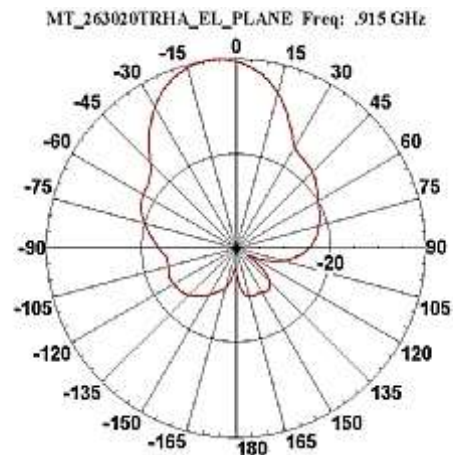

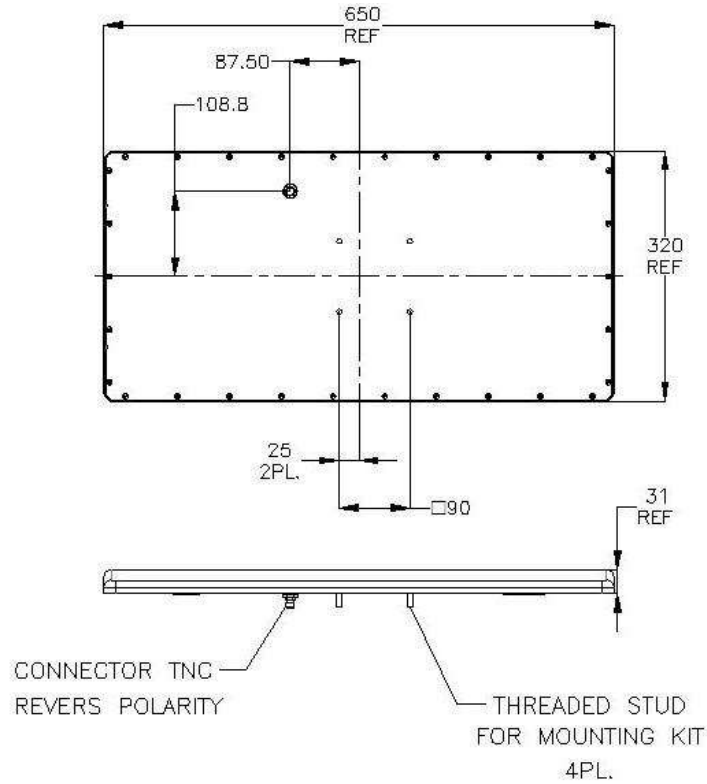

WAIVER!

While the information contained in this document has been carefully compiled to the best of our present knowledge, it is not intended as presentation or warranty of any kind on our part regarding the fitness of the products concerned for any particular use or purpose and neither shall any statement contained herein be construed as a recommendation to infringe any industrial property rights or as a license to use any such rights. The fitness of each product for any particular purpose must be checked beforehand with our specialists.

90C4090 "wide-beam", "high-gain" circular polarized RAIN RFID far field antenna

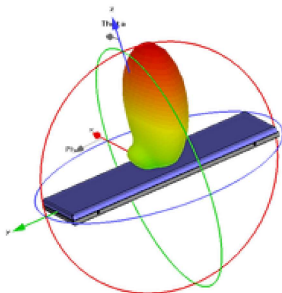

Far Field directivity

The Identix 90C4090 is a "Far Field" type UHF RFID antenna specifically designed for security applications (anti-theft) and loss prevention in retail - EAS Electronic Article Surveillance.

The 90C4090 antennas has a unique radiation lobe, ideal for applications where a confined reading zone is required such as storefronts and corridors.

The radiating lobe has an opening angle of 40° horizontally and 90° vertically, and an electric tilt of 15° in the horizontal direction.

Circular polarization with low axial ratio combined with high gain ensures efficient reading of tags regardless of orientation.

It has a compact, modern and lightweight design that allows easy of installation and aesthetic integration into different types of environments.

Applications

- RFID portals for loss prevention - LP and EAS
- General use UHF RFID portals
- Personnel and Vehicle access control

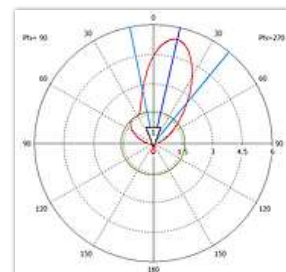

Radiation diagram

Product Details

- Operating frequency: 900-930MHz (FCC)
- Input Impedance: 50 Ohms
- Polarization: circular
- Far Field gain: +9dBic
- -3 dB Beamwidth - $40^\circ \times 90^\circ$ with 15° electric tilt
- VSWR: lower than 1.5:1 across all frequency band
- Axial ratio: 1dB @ 910MHz
- Maximum input power: 20W
- Connector: SMA female
- Dimensions:
 - 420mm x 140mm x 19mm
 - 16.5 x 5.5 x .75 in
- Ingress protection rating: IP64. Optional IP 67 on request.
- Base: painted aluminum
- Radome: PETG plastic 1.5mm thick
- Weight: 400g – 14 oz

ABOUT TIMES-7

Pushing the boundaries of RFID technology worldwide Times-7 are leaders in RFID antenna design and manufacture. Our patented award winning UHF antennas meet the needs of virtually any industry application; providing customers with fast accurate tracking of products, assets & people; empowering organizations to transform processes & reduce costs.

Our SlimLine range of antennas is unique in the RFID industry; offering high levels of performance & durability in an aesthetically superior form. Proven in a diverse & growing range of markets, applications include: retail & customer interaction, conference & people tracking, race timing, baggage handling, and logistic & supply chain asset management.

Times-7 Research Ltd
29 Railway Avenue
Lower Hutt 5010
New Zealand

NEW ZEALAND
P: +64 4 974 6566

USA/CANADA
P: +1 408 769 5025

E: info@times-7.com

www.times-7.com

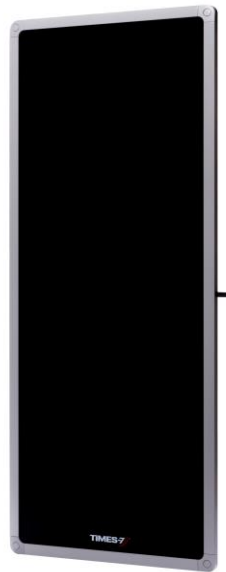

The SlimLine A6034

Up to 9m / 29 ft. read range

Just 12mm / 0.5 in. thick

High performance & rugged design

Suitable for indoor/outdoor use
& industrial applications

Part of the SlimLine range of multi-purpose antennas, the A6034 is an ultra-low profile high performance circularly polarized flat panel antenna. With a read range of up to 9 m / 29 ft. and a physical span of 747 mm (29.4 in.), this long length antenna is particularly suitable for portal applications where maximum read zone coverage is important.

Specifications

Physical / Environmental Specifications

Dimensions (L x W x D):	747 mm x 314 mm x 12 mm 29.4 " x 12.4 " x 0.5 "
Weight:	2.2kg / 4.8 lbs.
Radome Material:	Fire retardant ABS
Environmental Rating:	IP65
Operating / Storage Temperature:	-20° to +55°C / -30° to +65°C -4° to +131°F / -22° to +149°F
Mounting:	Integrated mounting holes / no accessory req.
Connector type / position:	SMA female side fly lead (300mm / 1ft)

Electrical Specifications

Frequency Range:	865-868 MHz / 902-928 MHz
Polarization:	Circular
Far-field Gain:	9 dBiC typical
Far-field 3 dB beamwidth:	25° in vertical, 81° in horizontal
VSWR	1.4 typical
Front to back ratio:	25 dB
Axial Ratio:	< 2 dB at boresight
Nominal impedance:	50 Ω
Anti-static protection:	DC grounded
Antenna detection	10 K Ω resistance
Maximum Input Power:	3 W

E-field elevation & Azimuth Patterns

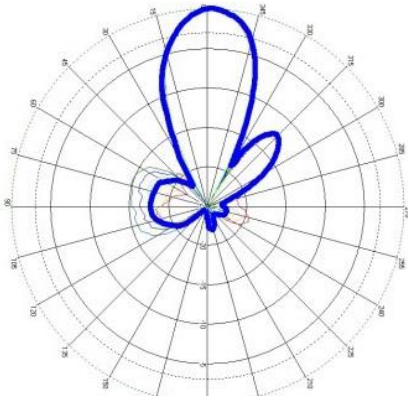

Vertical

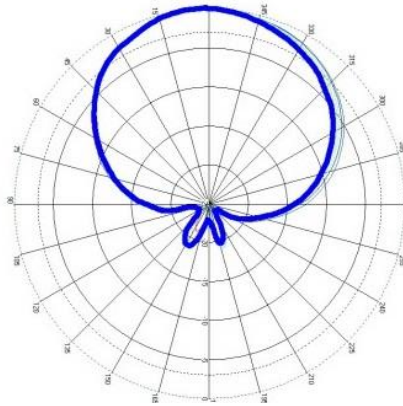

Horizontal

Ordering Information (please quote both product code & part no.)

Product Code	Band	Part No.
A6034	ETSI 865-868 MHz	70803
A6034	FCC 902-928 MHz	70809

OUR GLOBAL NETWORK

Constantly increasing market reach and influence in the global RFID industry, Times-7's international support spans The Americas, Europe, and Asia Pacific regions through our distributor, authorized reseller and integrated solutions provider network.

Applications

- High performance RFID applications where long / highly accurate read zones are required
- Space constrained / Customer facing environments
- All-weather rugged design suitable for industrial applications

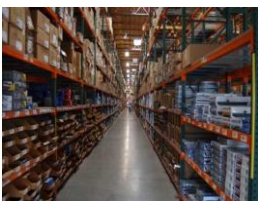

Times-7 Research Ltd
29 Railway Avenue
Lower Hutt 5010
New Zealand

NEW ZEALAND
P: +64 4 974 6566

USA/CANADA
P: +1 408 769 5025

E: info@times-7.com

www.times-7.com

The technical data contained in this publication is not a guarantee for which Times-7 Research Ltd assumes legal accountability. It is indicative of typical performance, and if required should be relied on for specific applications only after due verification.

All technical data, specifications and other information contained herein are deemed to be the proprietary intellectual property of Times-7 Research Ltd. No reproduction, copy or use thereof may be made without the express written consent of Times-7 Research Ltd.