



SDC-SSD40NBT

USER'S MANUAL

VERSION 4.1

global solutions: local support™

Americas: +1-800-492-2320 Option 3

Europe: +44-1628-858-940

Hong Kong: +852-2268-6567 x026

www.lairdtech.com/wireless

REVISION HISTORY

Version	Revision Date	Change Description
1.0	07/29/11	Initial Release Version (after preliminary versions) Finalized mechanical drawings. Revisions to pin table (I/O)
1.1	08/03/11	Corrected Control Signal Timing diagram and text
1.2	08/05/11	Changed Power Type column of Pin Definitions table
1.3	08/28/11	Added PCM Timing information
1.4	10/06/11	Added Wi-Fi/BT power consumption numbers Added note regarding the need for an external clock (pin 47) Updated antenna port information Added Appendix A: Schematic Added SSD30AG/SSD40NBT Pin Comparison table Added BT/AUX antenna port note
1.5	10/27/11	Added PCM defaults.
1.6	12/01/11	General edits including: Revisions to pin table Finalized Specifications data Added "Integration Considerations" section
1.7	12/02/11	Updated the MSD40NBT schematic. Updated Current Consumption numbers in the Specifications table. Added series resistors information to the "Integration Considerations" section Added product image
1.8	01/03/12	Updated Specification table
1.9	02/08/12	Add pin note and power notes
1.10	02/17/12	Updated Transmit Power numbers in the Specs table
2.0	4/17/12	Add AS/NZS (Australia, New Zealand) certifications Changed the name of Pin 20 Updated AS/NZS links
2.2	6/29/12	Updated BT Transmit Power
2.3	7/11/12	Updated schematic, Certifications, Typical Receiver Sensitivity
2.4	8/15/12	Updated Operating Temperature
3.0		Updated format (converted to Laird) Added "Note" with Figure 3
4.0	1/29/13	Updated Receive Sensitivity data Re-added MIC frequency band and operating channel information.
4.1	1/30/13	Updated 5Ghz channel data and frequency data Updated Operating Temperature data

CONTENTS

Revision History	2
Contents	3
Scope.....	4
Operational Description.....	4
Specifications	5
Recommended Operating Conditions and DC Electrical Characteristics.....	10
SDIO Timing Requirements	11
UART Timing Requirements	12
PCM Interface Timing.....	12
Control Signal Timing Requirements	17
Pin Definitions.....	18
SSD30AG and SSD40NBT Pin Comparison Table.....	21
Electrical Considerations.....	22
Integration Considerations	23
Mechanical Specifications.....	24
Mounting.....	25
Recommendations:	26
RF Layout Design Guidelines	27
Regulatory.....	28
Certified Antennas	28
Documentation Requirements	28
FCC	28
Industry Canada	29
European Union	30

Scope

This document describes key hardware aspects of the Summit SSD40NBT radio module. This document is intended to assist device manufacturers and related parties with the integration of this radio into their host devices. Data in this document are drawn from a number of sources and include information found in the Broadcom BCM4329 data sheet issued in June of 2009.

Please contact Summit or visit the Summit website at www.summitdata.com to obtain the most recent version of this document.

OPERATIONAL DESCRIPTION

This device is an SDC-SSD40NBT radio module which supports IEEE 802.11a/b/g/n standards via an SDIO (Secure Digital Input/Output) interface and Bluetooth version 2.1 via a serial UART (Universal Asynchronous Receiver/Transmitter) interface. The radio operates in unlicensed portions of the 2.4 GHz and 5 GHz radio frequency spectrum. The device is compliant with IEEE 802.11a, 802.11b, 802.11g, and 802.11n standards using Direct Sequence Spread Spectrum (DSSS), Orthogonal Frequency Division Multiplexing (OFDM), and supports Bluetooth 2.1 using Frequency Hopping Spread Spectrum (FHSS). The device supports all 802.11a, 802.11b, 802.11g, 802.11n, and Bluetooth data rates and automatically adjusts data rates and operational modes based on various environmental factors.



When operating on channels in the UNII-2 and UNII-2 Extended bands that are in the 5GHz portion of the frequency spectrum and are subject to Dynamic Frequency Selection requirements, the SDC-SSD40NBT fully conforms to applicable regulatory requirements. In the event that specified types of radar are detected by the network infrastructure, the SDC-SSD40NBT fully conforms to commands from the infrastructure for radar avoidance.

The SDC-SSD40NBT is a System in Package (SiP) Quad Flat pack, No leads (QFN) module and interfaces to host devices via a 56-pad edge connector. The device is based on the Broadcom BCM4329 chip which is an integrated device providing a Media Access Controller (MAC), a Physical Layer Controller (PHY or baseband processor), and fully integrated dual-band radio transceiver. To maximize operational range, the SDC-SSD40NBT incorporates a 5 GHz power amplifier (PA) to increase transmit power. The frequency stability for both 2.4 GHz (802.11b and 802.11g) and 5 GHz (802.11a) operation is +/- 20 ppm.

The SSD40NBT has its own RF shielding and does not require shielding provided by the host device into which it is installed in order to maintain compliance with applicable regulatory standards. As such, the device may be tested in a standalone configuration via an extender card.

The device buffers all data inputs so that it will comply with all applicable regulations even in the presence of over-modulated input from the host device. Similarly, the SDC-SSD40NBT incorporates power regulation to comply with all applicable regulations even when receiving excess power from the host device.

The SDC-SSD40NBT provides two diplexed antenna interfaces to support dual band transmit and receive diversity. Supported host device antenna types include dipole and monopole antennas.

Note: When using a single antenna, it must be connected to the AUX port. BT does not function on the Main port alone.

Regulatory operational requirements are included with this document and may be incorporated into the operating manual of any device into which the SDC-SSD40NBT is installed. The SDC-SSD40NBT is designed

for installation into mobile devices such as vehicle mount data terminals (which typically operate at distances greater than 20 cm from the human body) and portable devices such as handheld data terminals (which typically operate at distances less than 20 cm from the human body). See "[Documentation Requirements](#)" for more information.

SPECIFICATIONS

Table 1: Specifications

Feature	Description
Physical Interface	0.4mm pitch QFN (Quad Flat Pack, No Leads)
Wi-Fi Interface	1-bit or 4-bit Secure Digital I/O
Bluetooth Interface	Host Controller Interface (HCI) using High Speed UART
Main Chip	Broadcom BCM4329
Input Voltage Requirements	3.3 VDC \pm 10% (core)
I/O Signaling Voltage	1.8 to 3.3 VDC \pm 10%
Average Current Consumption, VDDIO = 3.3 volts (At maximum transmit power setting)	<p>802.11a (with BT in standby) Transmit: 282 mA (931 mW) Receive: 92 mA (304 mW) Standby: TBD</p> <p>802.11b (with BT in standby) Transmit: 314 mA (1036 mW) Receive: 92 mA (304 mW) Standby: TBD</p> <p>802.11g (with BT in standby) Transmit: 288 mA (950 mW) Receive: 92 mA (304 mW) Standby: TBD</p> <p>802.11n (2.4 GHz) (with BT in standby) Transmit: 292 mA (964 mW) Receive: 92 mA (304 mW) Standby: TBD</p> <p>802.11n (5 GHz) (with BT in standby) Transmit: 270 mA (891 mW) Receive: 92 mA (304 mW) Standby: TBD</p> <p>Bluetooth (with Wi-Fi in standby) Transmit: TBD Receive: TBD</p>
<i>Note: Standby refers to the radio operating in PM1 powersave mode.</i>	
Operating Temperature	-30° to 80°C (-22° to 176°F)
Operating Humidity	10 to 90% (non-condensing)
Storage Temperature	-30° to 85°C (-22° to 185°F)
Storage Humidity	10 to 90% (non-condensing)
Maximum Electrostatic Discharge	8 kV
Length	15.0 mm (0.59")
Width	15.0 mm (0.59")
Thickness	2.50 mm (0.1")
Weight	1.0 g (0.04 oz.)
Mounting	See the " Mounting " section for more information.
Wi-Fi Media	Direct Sequence-Spread Spectrum (DSSS)

Feature	Description
	Complementary Code Keying (CCK) Orthogonal Frequency Divisional Multiplexing (OFDM)
Bluetooth Media	Frequency Hopping Spread Spectrum (FHSS)
Wi-Fi Media Access Protocol	Carrier sense multiple access with collision avoidance (CSMA/CA)
Network Architecture Types	Infrastructure and ad hoc
Wi-Fi Standards	IEEE 802.11a, 802.11b, 802.11d, 802.11e, 802.11g, 802.11h, 802.11i, 802.11n
Bluetooth Standards	Bluetooth version 2.1 with Enhanced Data Rate
Wi-Fi Data Rates Supported	802.11a (OFDM) 6, 9, 12, 18, 24, 36, 48, 54 Mbps 802.11b (DSSS, CCK) 1, 2, 5.5, 11 Mbps 802.11g (OFDM) 6, 9, 12, 18, 24, 36, 48, 54 Mbps 802.11n (OFDM, MCS 0-7) 6.5, 7.2, 13.0, 14.4, 19.5, 21.7, 26.0, 28.9, 39.0, 43.3, 52.0, 57.8, 58.5, 65.0, 72.2 Mbps
Modulation	BPSK @ 1, 6, 6.5, 7.2 and 9 Mbps QPSK @ 2, 12, 13, 14.4, 18, 19.5 and 21.7 Mbps CCK @ 5.5 and 11 Mbps 16-QAM @ 24, 26, 28.9, 36, 39 and 43.3 Mbps 64-QAM @ 48, 52, 54, 57.8, 58.5, 65, and 72.2 Mbps
802.11n Spatial Streams	1 (Single Input, Single Output)
Bluetooth Data Rates Supported	1, 2, 3 Mbps
Bluetooth Modulation	GFSK@ 1 Mbps Pi/4-DQPSK@ 2 Mbps 8-DPSK@ 3 Mbps
Regulatory Domain Support	FCC (Americas, Parts of Asia, and Middle East) ETSI (Europe, Middle East, Africa, and Parts of Asia) MIC (Japan) (formerly TELEC) KC (Korea) (formerly KCC)
2.4 GHz Frequency Bands	ETSI 2.4 GHz to 2.483 GHz FCC 2.4 GHz to 2.473 GHz MIC 2.4 GHz to 2.495 GHz KCC 2.4 GHz to 2.483 GHz
2.4 GHz Operating Channels	ETSI: 13 (3 non-overlapping) FCC: 11 (3 non-overlapping) MIC: 14 (4 non-overlapping) KCC: 13 (3 non-overlapping)



Feature	Description
5 GHz Frequency Bands	<p>ETSI 5.15 GHz to 5.35 GHz 5.47 GHz to 5.725 GHz</p> <p>FCC 5.15 GHz to 5.35 GHz 5.47 GHz to 5.725 GHz 5.725 GHz to 5.82 GHz</p> <p>MIC (Japan) 5.15 GHz to 5.35 GHz</p> <p>KC 5.15 GHz to 5.35 GHz 5.725 GHz to 5.82 GHz</p>
5 GHz Operating Channels	<p>ETSI: 19 non-overlapping FCC: 23 non-overlapping MIC (Japan): 8 non-overlapping KC: 12 non-overlapping</p>
Transmit Power	<p>802.11a 6 Mbps 16 dBm (40 mW) 54 Mbps 14 dBm (25 mW)</p> <p>802.11b 1 Mbps 17 dBm (50 mW) 11 Mbps 16 dBm (40 mW)</p> <p>802.11g 6 Mbps 15 dBm (32 mW) 54 Mbps 13 dBm (20mW)</p> <p>802.11n (2.4 GHz) 6.5 Mbps (MCS0) 15 dBm (32 mW) 65 Mbps (MCS7) 11 dBm (13 mW)</p> <p>802.11n (5 GHz) 6.5 Mbps (MCS0) 16 dBm (40 mW) 65 Mbps (MCS7) 13 dBm (20 mW)</p> <p>Bluetooth 1 Mbps 0 dBm (1mW) 2 Mbps 0 dBm (1mW) 3 Mbps 0 dBm (1mW)</p>
Typical Receiver Sensitivity	<p>802.11a: 6 Mbps -90 dBm 24 Mbps -84 dBm 54 Mbps -75 dBm (PER <= 10%)</p> <p>802.11b: 1 Mbps -96 dBm 11 Mbps -89 dBm (PER <= 10%)</p> <p>802.11g: 6 Mbps -90 dBm 24 Mbps -84 dBm 54 Mbps -74 dBm (PER <= 10%)</p> <p>802.11n (2.4 GHz) MCS0 Mbps -90 dBm MCS4 Mbps -79 dBm MCS7 Mbps -72 dBm</p> <p>802.11n (5 GHz) MCS0 Mbps -89 dBm</p>

Note: Transmit power varies according to individual country regulations. All values nominal, +/-2 dBm.

Note: Summit 40 series radios support a single spatial stream and 20 MHz channels only.

Note: All values nominal, +/-3 dBm.

Feature	Description
	MCS4 Mbps -79 dBm MCS7 Mbps -71 dBm
	Bluetooth:
	1 Mbps TBD
	2 Mbps TBD
	3 Mbps TBD
Operating Systems Supported	Windows Mobile 6.5 Windows Mobile 6.1 Windows Mobile 6.0 Windows Mobile 5.0 Windows Embedded CE 7.0 Windows Embedded CE 6.0 R3 Windows Embedded CE 6.0 R2 Windows Embedded CE 6.0 Windows Embedded CE 5.0 Linux, 2.6.x, 3.x.x kernel
Security	Standards Wireless Equivalent Privacy (WEP) Wi-Fi Protected Access (WPA) IEEE 802.11i (WPA2) Encryption Wireless Equivalent Privacy (WEP, RC4 Algorithm) Temporal Key Integrity Protocol (TKIP, RC4 Algorithm) Advanced Encryption Standard (AES, Rijndael Algorithm) Encryption Key Provisioning Static (40-bit and 128-bit lengths) Pre-Shared (PSK) Dynamic 802.1X Extensible Authentication Protocol Types EAP-FAST EAP-TLS EAP-TTLS PEAP-GTC PEAP-MSCHAPv2 PEAP-TLS LEAP

Feature	Description
Compliance	<p>ETSI Regulatory Domain</p> <p>EN 300 328</p> <p>EN 300 328 v1.7.1 (BT 2.1)</p> <p>EN 301 489-1</p> <p>EN 301 489-17</p> <p>EN 301 893</p> <p>EN 60950-1</p> <p>EU 2002/95/EC (RoHS)</p> <p>FCC Regulatory Domain</p> <p>FCC 15.247 DTS – 802.11b/g (Wi-Fi) – 2.4 GHz & 5.8 GHz</p> <p>FCC 15.407 UNII – 802.11a (Wi-Fi) – 2.4 GHz & 5.4 GHz</p> <p>FCC 15.247 DSS – BT 2.1</p> <p>Industry Canada</p> <p>RSS-210 – 802.11a/b/g/n (Wi-Fi) – 2.4 GHz, 5.8 GHz, 5.2 GHz, and 5.4 GHz</p> <p>RSS-210 – BT 2.1</p> <p>AS/NZS</p> <p>AS/NZS 4268:2008 +A1:2010 (RLAN device)</p> <p>AS/NZS 4268:2008 +A1:2010 (BT device)</p>
Certifications	<p>Wi-Fi Alliance</p> <p>802.11a, 802.11b, 802.11g , 802.11n</p> <p>WPA Enterprise</p> <p>WPA2 Enterprise</p> <p>Cisco Compatible Extensions (Version 4)</p> <p>Bluetooth SIG Qualification</p>   
Warranty	Limited Lifetime
<i>All specifications are subject to change without notice</i>	

Note: The BCM4329 has an internal power-on (POR) circuit. The device will be held in reset for a maximum of 110 ms after VDDC and VDDIO have both passed the 0.6V threshold. Wait at least 110 ms after VDDC and VDDIO are available before initiating SDIO accesses. The external reset signals are logically ORed with this POR. SO if either the internal POR or one of the external resets are asserted, the device will be reset.

RECOMMENDED OPERATING CONDITIONS AND DC ELECTRICAL CHARACTERISTICS

Table 2: Recommended Operating Conditions and DC Electrical Characteristics

Symbol	Parameter	Min	Typ	Max	Unit
VCC	DC Supply Voltage	3.0	3.3	3.6	V
VDD_IO	DC Supply Voltage (I/O)	1.8	-	3.3	V
V _{IL}	Low Level Input Voltage (VDDO = 3.3V)	-	-	0.8	V
V _{IH}	High Level Input Voltage (VDDO = 3.3V)	2.0	-	-	V
V _{IL}	Low Level Input Voltage (VDDO = 1.8V)	-	-	0.6	V
V _{IH}	High Level Input Voltage (VDDO = 1.8V)	1.1	-	-	V
V _{OL}	Low Level Output Voltage (100 μ A load)	-	-	0.2	V
V _{OH}	High Level Output Voltage (-100 μ A load)	VDDIO - 0.2V	-	-	V
I _{IL}	Low Current Input	-	0.3	-	μ A
I _{IH}	High Current Input	-	0.3	-	μ A
I _{OL}	Low Current Output (VDDO = 3.3V, V _{OL} = 0.4V)	-	-	3.0	mA
I _{OH}	High Current Output (VDDO = 3.3V, V _{OH} = 2.9V)	-	-	3.0	mA
C _{IN}	Input Capacitance	-	-	5	pF
	BT UART Baud Rate	9600 bps	115.2 Kbps (default coming out of reset)	4 Mbps	bps/Kbps/Mbps

SDIO Timing Requirements

The following figure (Figure 2) and table display SDIO default mode timing.

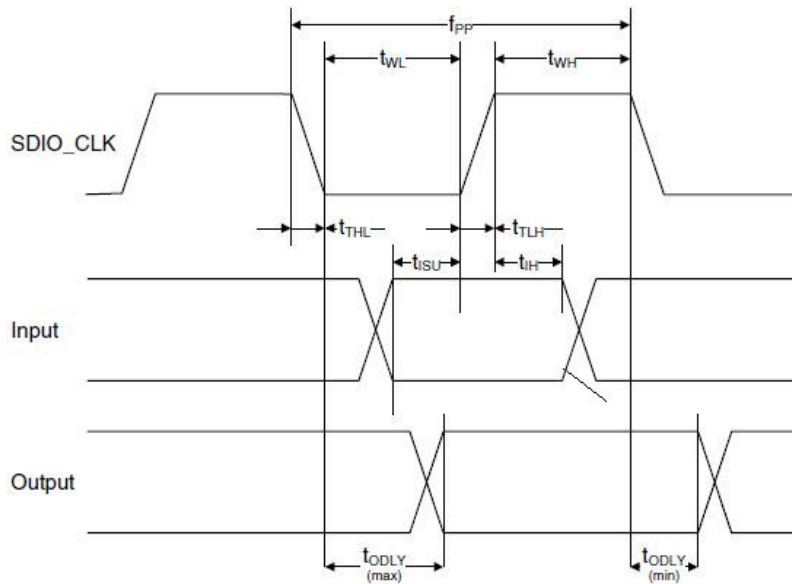

Figure 1: SDIO Default Mode Timing

Note: Timing is based on $CL \leq 40pF$ load on CMD and Data.

Table 3: SDIO Timing Requirements

Symbol	Parameter	Min	Typ	Max	Unit
SDIO CLK (All values are referred to minimum V_{IH} and maximum V_{IL}*)					
f_{PP}	Frequency – Data Transfer mode	0	-	25	MHz
f_{OD}	Frequency – Identification mode	0	-	400	kHz
t_{WL}	Clock low time	10	-	-	ns
t_{WH}	Clock high time	10	-	-	ns
t_{TLH}	Clock rise time	-	-	10	ns
t_{THL}	Clock low time	-	-	10	ns
Inputs: CMD, DAT (referenced to CLK)					
t_{ISU}	Input setup time	5	-	-	ns
t_{IH}	Input hold time	5	-	-	ns
Outputs: CMD, DAT (referenced to CLK)					
t_{ODLY}	Output delay time – Data Transfer mode	0	-	14	ns
t_{ODLY}	Output delay time – Identification mode	0	-	50	ns
* $\min(V_{ih}) = 0.7 \times V_{DDIO}$ and $\max(V_{il}) = 0.2 \times V_{DDIO}$.					

UART Timing Requirements

The following figure (Figure 3) displays UART timing.

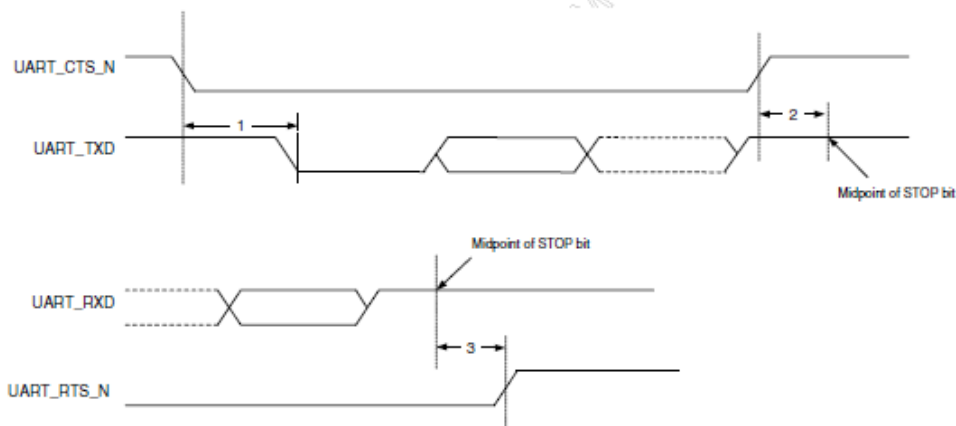

Figure 2: UART Timing Requirements

Notes: The UART 4-wire interface supports Bluetooth 2.1 HCI Specification. PCM data frames are sent MSB first.

Table 4: UART Timing Requirements

Reference	Description	Min.	Typ.	Max.	Unit
1	Delay time, BT_UART_CTS_N low to UART_TXD valid	-	-	24	Baudout cycles
2	Setup time, BT_UART_CTS_N high before midpoint of stop bit	-	-	10	ns
3	Delay time, midpoint of stop bit to BT_UART_RTS_N high	-	-	2	Baudout cycles

PCM Interface Timing

- [PCM Defaults](#)
- [Short Frame Sync, Master Mode](#)
- [Short Frame Sync, Slave Mode](#)
- [Long Frame Sync, Master Mode](#)
- [Long Frame Sync, Slave Mode](#)

PCM Defaults

SCO Routing	PCM
Clock Mode	Master
Sync Mode	Master
Frame Type	Short

Interface Rate	512
Sample Interval	8khz
16 bit mono	

Frame Sync, Master Mode

Figure 3: Short Frame Sync, Master Mode

Table 5: Short Frame Sync, Master Mode

Reference	Description	Min.	Typ.	Max.	Unit
1	PCM bit clock frequency	128	-	2048	kHz
2	PCM bit clock high time	128	-	-	ns
3	PCM bit clock low time	209	-	-	ns
4	Delay from BT_PCM_CLK rising edge to BT_PCM_SYNC high	-	-	50	ns
5	Delay from BT_PCM_CLK rising edge to BT_PCM_SYNC low	-	-	50	ns
6	Delay from BT_PCM_CLK rising edge to data valid on BT_PCM_OUT	-	-	50	ns
7	Setup time for BT_PCM_IN before BT_PCM_CLK falling edge	50	-	-	ns
8	Hold time for BT_PCM_IN after BT_PCM_CLK falling edge	10	-	-	ns
9	Delay from falling edge of BT_PCM_CLK during last bit period to BT_PCM_OUT becoming high impedance	-	-	50	ns

Short Frame Sync, Slave Mode

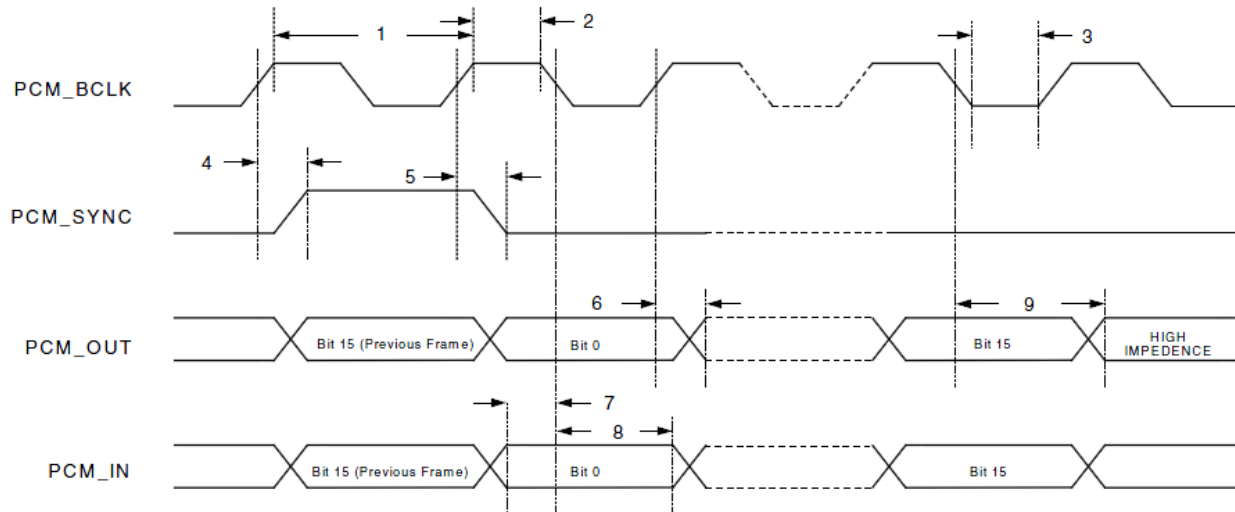
Figure 4: Short Frame Sync, Slave Mode

Table 6: Short Frame Sync, Slave Mode

Reference	Description	Min.	Typ.	Max.	Unit
1	PCM bit clock frequency	128	-	2048	kHz
2	PCM bit clock high time	209	-	-	ns
3	PCM bit clock low time	209	-	-	ns
4	Setup time for BT_PCM_SYNC before falling edge of BT_PCM_BCLK	50	-	-	ns
5	Hold time for BT_PCM_SYNC after falling edge of BT_PCM_CLK	10	-	-	ns
6	Hold time of BT_PCM_OUT after BT_PCM_CLK falling time	-	-	175	ns
7	Setup time for BT_PCM_IN before BT_PCM_CLK falling edge	50	-	-	ns
8	Hold time for BT_PCM_IN after BT_PCM_CLK falling edge	10	-	-	ns
9	Delay from falling edge of BT_PCM_CLK during last bit period to BT_PCM_OUT becoming high impedance	-	-	100	ns

Long Frame Sync, Master Mode

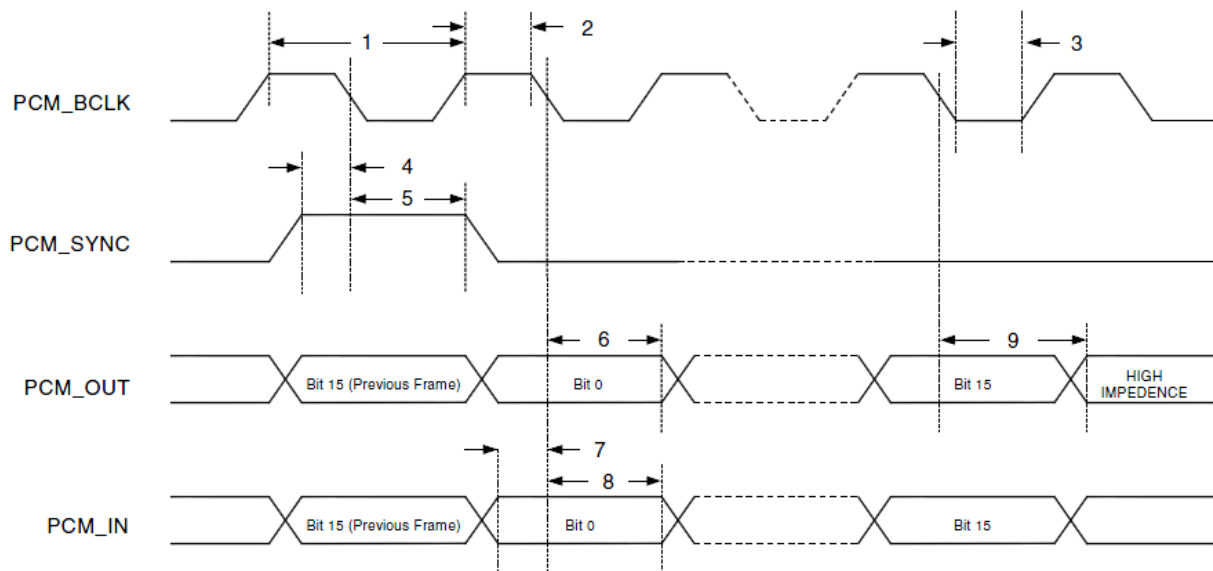
Figure 5: Long Frame Sync, Master Mode

Table 7: Long Frame Sync, Master Mode

Reference	Description	Min.	Typ.	Max.	Unit
1	PCM bit clock frequency	128	-	2048	kHz
2	PCM bit clock high time	209	-	-	ns
3	PCM bit clock low time	209	-	-	ns
4	Delay from BT_PCM_CLK rising edge to BT_PCM_SYNC high during first bit time	-	-	50	ns
5	Delay from BT_PCM_CLK rising edge to BT_PCM_SYNC low during third bit time	-	-	50	ns
6	Delay from BT_PCM_CLK rising edge to data valid on BT_PCM_OUT	-	-	50	ns
7	Setup time for BT_PCM_IN before BT_PCM_CLK falling edge	50	-	-	ns
8	Hold time for BT_PCM_IN after BT_PCM_CLK falling edge	10	-	-	ns
9	Delay from falling edge of BT_PCM_CLK during last bit period to BT_PCM_OUT becoming high impedance	-	-	50	ns

Long Frame Sync, Slave Mode

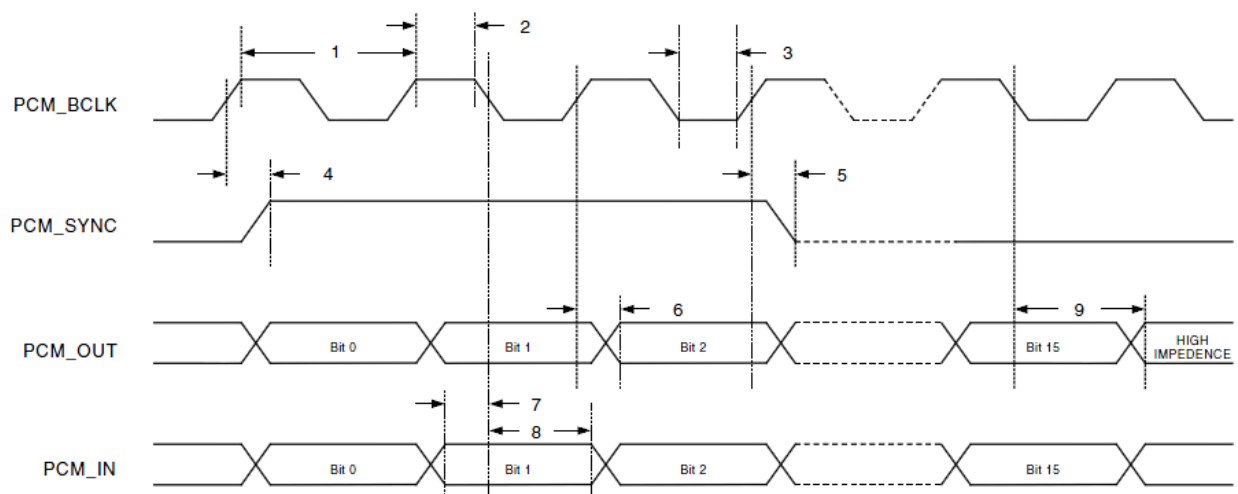
Figure 6: Long Frame Sync, Slave Mode

Table 8: Long Frame Sync, Slave Mode

Reference	Description	Min.	Typ.	Max.	Unit
1	PCM bit clock frequency	128	-	2048	kHz
2	PCM bit clock high time	209	-	-	ns
3	PCM bit clock low time	209	-	-	ns
4	Setup time for BT_PCM_SYNC before falling edge of BT_PCM_CLK during first bit time	50	-	-	ns
5	Hold time for BT_PCM_SYNC after falling edge of BT_PCM_CLK during second bit period. Note: BT_PCM_SYNC may go low any time from second bit period to last bit period.	10	-	-	ns
6	Delay from rising edge of BT_PCM_CLK or BT_PCM_SYNC (whichever is later) to data valid for first bit on BT_PCM_OUT	-	-	50	ns
7	Hold time of BT_PCM_OUT after BT_PCM_CLK falling edge	-	-	175	ns
8	Setup time for BT_PCM_IN before BT_PCM_CLK falling edge	50	-	-	ns
9	Hold time for BT_PCM_IN after BT_PCM_CLK falling edge	10	-	-	ns
10	Delay from falling edge of BT_PCM_CLK or BT_PCM_SYNC (whichever is later) during last bit in slot to BT_PCM_OUT becoming high impedance	-	-	100	

Control Signal Timing Requirements

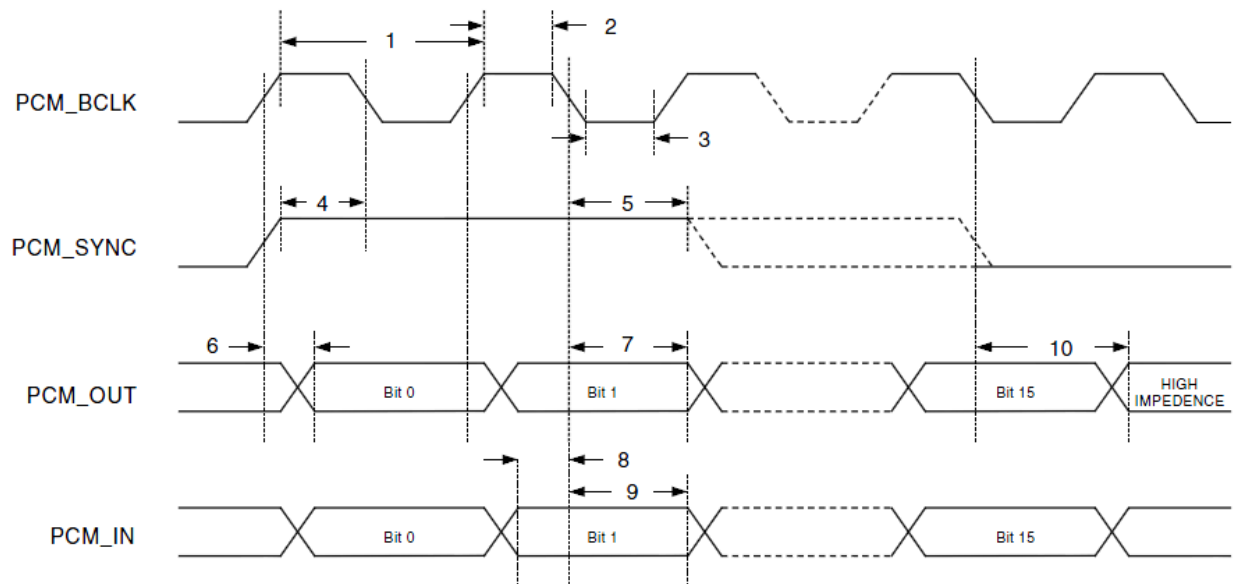
The following figure (Figure 4) displays Control Signal timing.

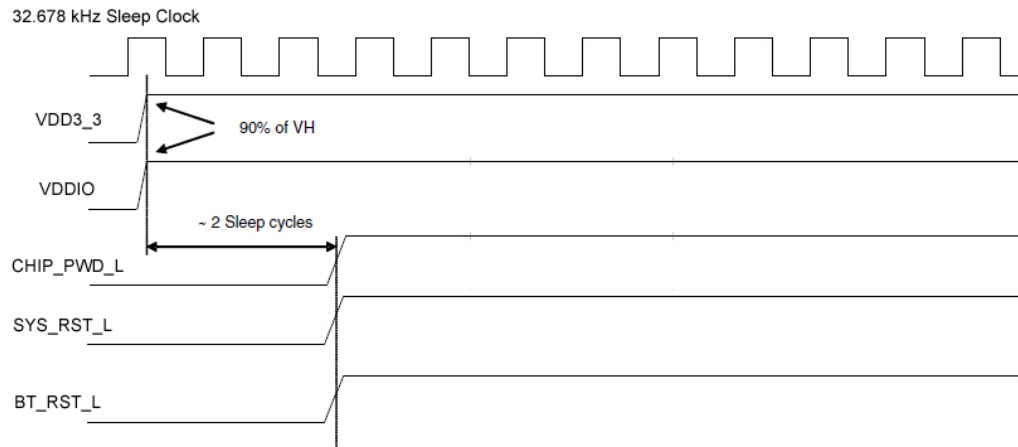

Figure 7: Control Signal Timing WLAN = ON, Bluetooth = ON

Note: This radio has an integrated power-on reset circuit that resets all circuits to a known power-on state. Individual resets can also be driven by BT_RST_N or SYS_RST_N (an active-low, external reset signal which can be used to externally force the device into a power-on reset state).

Pin Definitions

WLAN	Bluetooth	WLAN/Bluetooth
------	-----------	----------------

Table 9: Pin Definitions

Pin Number	Pin Name	I/O	Voltage Reference	Description
1	GND	-		Ground
2	GND	-		Ground
3	GND	-		Ground
4	GND	-		Ground
5	ANT_2	I/O		Antenna 2 (Auxiliary) 50 ohm coplanar wave guide to antenna or antenna connector. IMPORTANT: BT functions on the Auxiliary (AUX) port and <i>not</i> on the Main port. For Wi-Fi and BT single-antenna implementations, the AUX port <i>must</i> be used.
6	GND	-		Ground
7	GND	-		Ground
8	GND	-		Ground
9	GND	-		Ground
10	ANT_1	I/O		Antenna 1 (Main) 50 ohm coplanar wave guide to antenna or antenna connector. IMPORTANT: BT functions on the AUX port and <i>not</i> on the Main port. For Wi-Fi and BT single-antenna implementations, the AUX port <i>must</i> be used.
11	GND	-		Ground
12	GND	-		Ground
13	GND	-		Ground
14	GND	-		Ground
15	GND	-		Ground
16	GND	-		Ground
17	GND	-		Ground
18	GND	-		Ground
19	BT_PCM_OUT	O	VDDIO	PCM data output

Pin Number	Pin Name	I/O	Voltage Reference	Description
20	BT_WAKE_B	I	VDDIO	Bluetooth device wake-up: Signal from the host to the SDC-SSD40NBT indicating that the host requires attention. Asserted: Bluetooth device must wake-up or remain awake Deasserted: Bluetooth device may sleep when sleep criteria are met The polarity of this signal is software configurable and can be asserted high or low. Note: The default is low but this is only applicable for specific Bluetooth Sleep mode settings. By default, the radio has "No Sleep Mode Set".
21	BT_HOST_WAKE_B	O	VDDIO	Host Wake-up Signal from the SDC-SSD40NBT to the host indicating that the radio requires attention. Asserted: Host device must wake-up or remain awake. Deasserted: Host device may sleep when sleep criteria are met The polarity of this signal is software configurable and can be asserted high or low. Note: The default is low but this is only applicable for specific Bluetooth Sleep mode settings. By default, the radio has "No Sleep Mode Set".
22	RSVD	O	VDDIO	Bluetooth LED Activity Indicator; active high.
23	VDD3_3	-		3.3V Power
24	GND	-		Ground
25	BT_UART_CTS_N	I	VDDIO	Clear-to-send signal for the Bluetooth UART interface, active low.
26	BT_UART_RTS_N	O	VDDIO	Request-to-send signal for the Bluetooth UART interface, active low.
27	BT_UART_TXD	O	VDDIO	Bluetooth UART Serial Output.
28	BT_UART_RXD	I	VDDIO	Bluetooth UART Serial Input.
29	BT_PCM_SYNC	I/O	VDDIO	PCM sync signal Default master (output); can be configured slave (input)
30	BT_PCM_IN	I	VDDIO	PCM data input
31	BT_PCM_CLK	I/O	VDDIO	PCM clock
32	VDDIO		VDDIO	1.8/3.3V I/O Power This is the reference pins for all I/O signaling pins; it accepts 1.8VDC or 3.3VDC from the host.
33	RSVD	O	VDDIO	Reserved for WLAN LED activity indicator.
34	RSVD	O	VDDIO	Reserved for Wake on Wireless.
35	SYS_RST_L	I	VDDIO	Resets the WLAN radio, active low. Must be asserted when power is first applied to the radio, then released before any transaction can start (see Note).

Pin Number	Pin Name	I/O	Voltage Reference	Description
				See " Electrical Considerations " for the recommended SYS_RST_L circuitry
36	CHIP_PWD_L	I	VDDIO	Powers down both the BT and WLAN radios, active low (see Note).
37	BT_RST_L	I	VDDIO	Resets the Bluetooth radio, active low. Must be asserted when power is first applied to the radio, then released before any transaction can start. Note: See " Integration Considerations " for additional integration information.
38	SDIO_DATA_0	I/O	VDDIO	SDIO Data 0 Note: See " Integration Considerations " for additional integration information.
39	GND	-		Ground
40	SDIO_CLK	I	VDDIO	SDIO Clock (25MHz max) Note: See " Integration Considerations " for additional integration information.
41	GND	-		Ground
42	SDIO_DATA_1	I/O	VDDIO	SDIO Data 1
43	SDIO_DATA_3	I/O	VDDIO	SDIO Data 3
44	SDIO_DATA_2	I/O	VDDIO	SDIO Data 2
45	SDIO_CMD	I/O	VDDIO	SDIO Command
46	GND	-		Ground
47	CLK_32K	I		32k Ext Sleep Clock Note: The Broadcom BCM4329 (the core of the SSD40NBT) does not have an internal sleep clock. The SSD40NBT requires an external 32K sleep clock. Summit recommends the ECS-327KE or similar product.
48	RSVD	I	VDDIO	Reserved, No Connect
49	RSVD	O	VDDIO	Reserved, No Connect
50	RSVD	I/O	VDDIO	Reserved, No Connect
51	RSVD	I/O	VDDIO	Reserved for GPIO. Leave open (float).
52	RSVD	I/O	VDDIO	Reserved, No Connect
53	RSVD	I/O	VDDIO	Reserved for GPIO. No Connect.
54	RSVD	I/O	VDDIO	Reserved for GPIO. No Connect.
55	RSVD	I/O	VDDIO	Reserved for GPIO. No Connect.
56	RSVD	I/O	VDDIO	Reserved for GPIO. No Connect.

Note Regarding SYS_RST_L and CHIP_PWD_L:

Simply releasing SYS_RST_L and CHIP_PWD_L does not guarantee that the BCM4329 chip in the SSD40NBT module comes out of reset. Ensure that both VDD and VDDIO have been applied to the SSD40NBT for at least 110 ms before attempting to initiate SDIO communications. A slightly longer delay is better (safer).

SSD30AG and SSD40NBT Pin Comparison Table

Pin #	SSD30AG Pin Name	SSD40NBT Pin Name	Pin #	SSD30AG Pin Name	SSD40NBT Pin Name
1	GND	GND	29	RSVD	BT_PCM_SYNC
2	GND	GND	30	RSVD	BT_PCM_IN
3	GND	GND	31	RSVD	BT_PCM_CLK
4	GND	GND	32	VDDIO	VDDIO
5	ANT_2	ANT_2	33	WL_LED_ACT	RSVD
6	GND	GND	34	WL_GPIO_1	RSVD
7	GND	GND	35	SYS_RST_L	SYS_RST_L
8	GND	GND	36	CHIP_PWD_L	CHIP_PWD_L
9	GND	GND	37	RSVD	BT_RST_L
10	ANT_1	ANT_1	38	SDIO_DATA_0	SDIO_DATA_0
11	GND	GND	39	GND	GND
12	GND	GND	40	SDIO_CLK	SDIO_CLK
13	GND	GND	41	GND	GND
14	GND	GND	42	SDIO_DATA_1	SDIO_DATA_1
15	GND	GND	43	SDIO_DATA_3	SDIO_DATA_3
16	GND	GND	44	SDIO_DATA_2	SDIO_DATA_2
17	GND	GND	45	SDIO_CMD	SDIO_CMD
18	GND	GND	46	GND	GND
19	RSVD	BT_PCM_OUT	47	RSVD	CLK_32K
20	RSVD	RSVD	48	SDIO_SEL	RSVD
21	RSVD	BT_HOST_WAKE_B	49	WLAN_ACTIVE	RSVD
22	RSVD	RSVD	50	BT_PRIORITY	RSVD
23	VCC3_3	VDD3_3	51	BT_FREQ	RSVD
24	GND	GND	52	BT_ACTIVE	RSVD
25	RSVD	BT_UART_CTS_N	53	RSVD	RSVD
26	RSVD	BT_UART_RTS_N	54	RSVD	RSVD
27	RSVD	BT_UART_TXD	55	RSVD	RSVD
28	RSVD	BT_UART_RXD	56	RSVD	RSVD

Electrical Considerations

Below is a section of the schematic for the MSD40NBT, a PCB module based on the SSD40NBT. Summit provides this for your reference only to aid you in integrating the SSD40NBT into your device.

Note: The full MSD40NBT schematic is located in [Appendix A: Schematic](#).

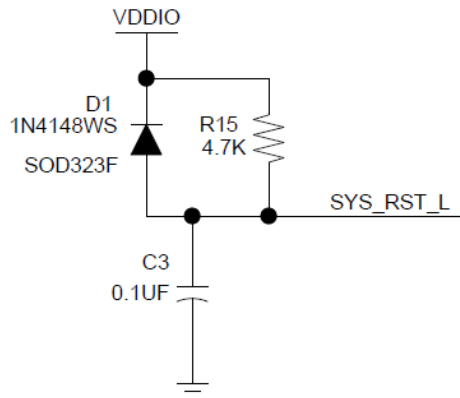

Figure 8: Recommended circuit for SYS_RST_L

Note: In the reset circuit, the diode is placed in parallel with the resistor to ensure the capacitor is discharged quickly when a power drop occurs. This minimizes the chance of register corruption within the processor and Wi-Fi module should such a power supply glitch arise.

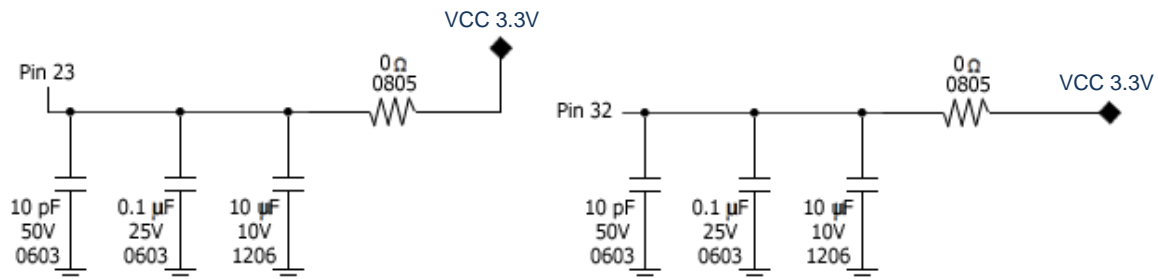

Figure 9: Recommended supply bypass

Note: The 10uF bypass capacitors must be a low-ESR type.

Note: The 0 ohm resistors are optional and could be replaced by a chip ferrite bead, if desired.

Integration Considerations

The following Wi-Fi and Bluetooth information should be taken into consideration when integrating the SSD40NBT.

Wi-Fi

Series resistors are recommended in all six SDIO lines (27-56 ohms typically):

- SDIO_CLK
- SDIO_CMD
- SDIO_DATA_0
- SDIO_DATA_1
- SDIO_DATA_2
- SDIO_DATA_3

Note: Although these values may vary with the properties of your host interface and the PCB, they are a reasonable starting point.

Note: The series resistors in the SDIO bus provide several design benefits:

- If a host controller has too high of a drive strength, then bus ringing may result. Series resistors can reduce this ringing on the I/O lines.
 - Adding 27-56 ohms of series resistance on the SDIO bus will reduce sharp transitional edges, which may reduce EMI.
 - Having the series resistors in the PCB layout allows for design flexibility; If they are later found to be unnecessary, zero (0) ohm jumpers may be used in their place
-

The following are also recommended:

- 47 K ohm pull-ups on the CMD line and four data lines: SDIO_CMD, SDIO_DATA_0, SDIO_DATA_1, SDIO_DATA_2, SDIO_DATA_3
-

Note: No pull-up is required on the CLK line.

Note: Make sure to apply the proper voltage on the VDDIO input to the SiP to match the signaling voltage of the SDIO host interface (1.8V or 3.3V typically, but it can be anything in between these values).

Note: The SDIO host must wait a minimum of 110 ms before initiating access to the SDC-SSD40NBT after VDD ramps up and settles.

Bluetooth

When the BT radio is not being used, the BT_RST_L line may be held low to save some overall current consumption.

When the BT radio is being used, the BT_RST_L line may be left floating (because there is a 10 K ohm pull-up resistor on this line inside the SSD40NBT SiP).

If the BT_RST_L is coming from a GPIO from the host processor, then it may be easier (although not necessary) to assert a HIGH on this line, rather than making it an input.

MECHANICAL SPECIFICATIONS

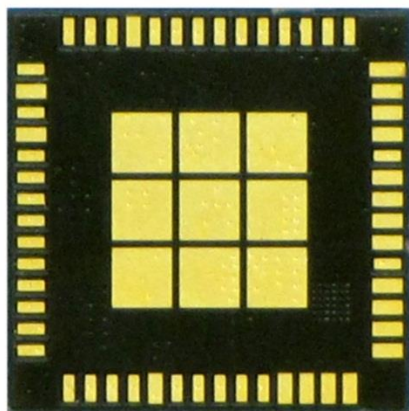
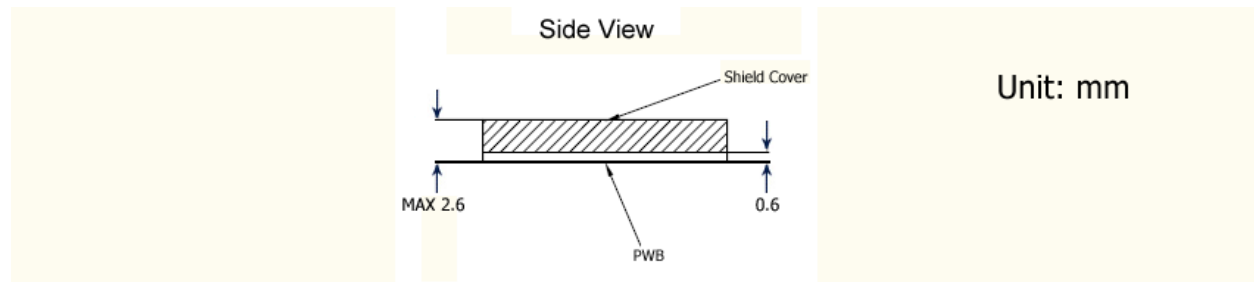
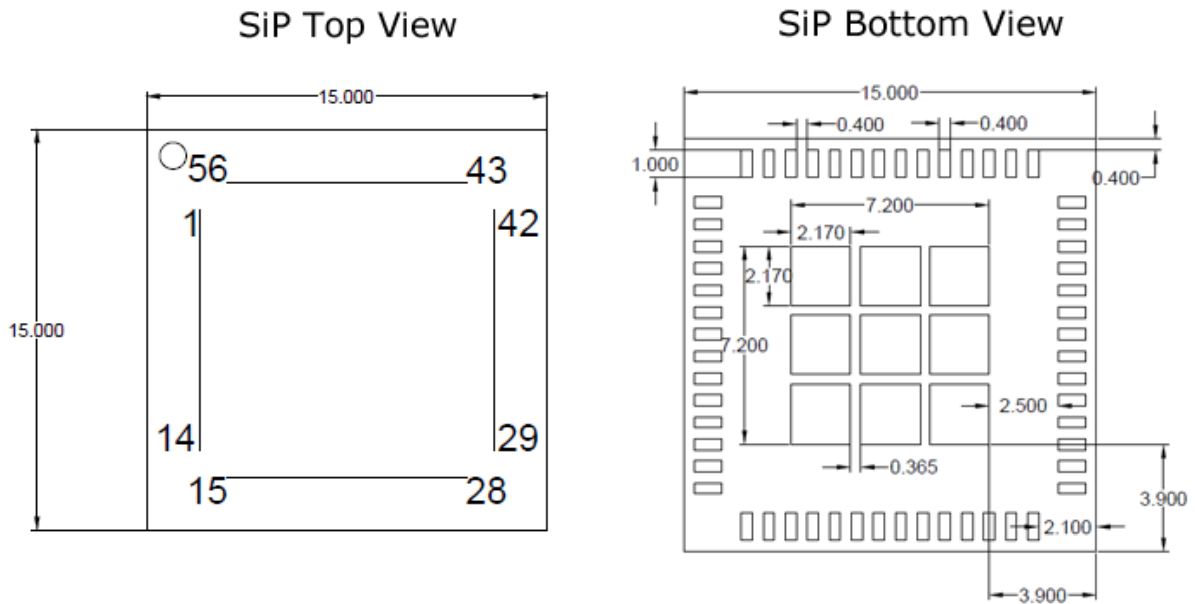
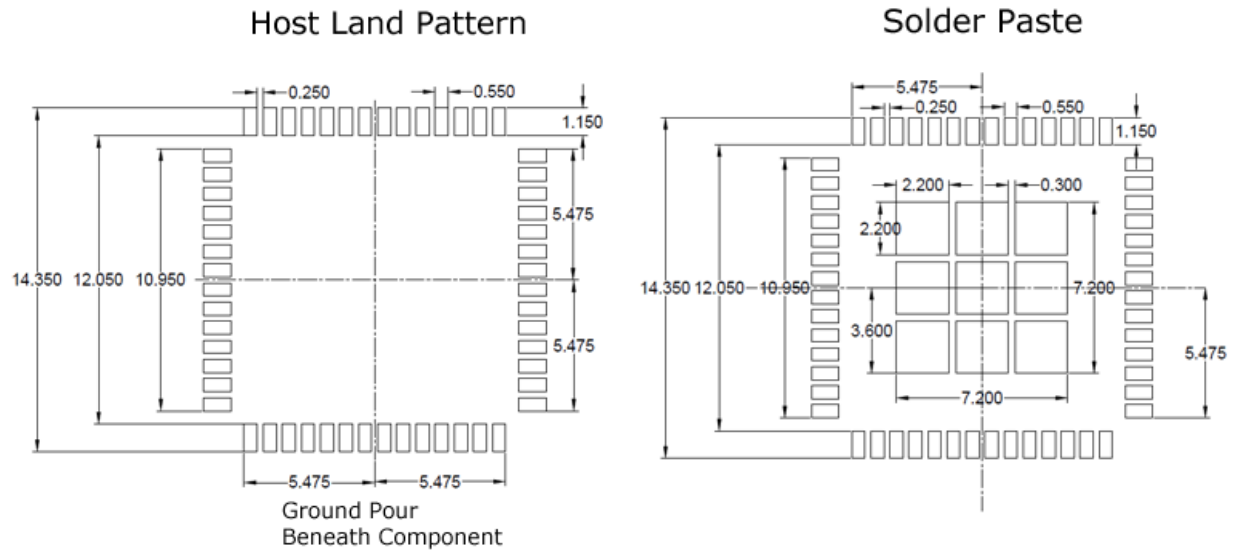
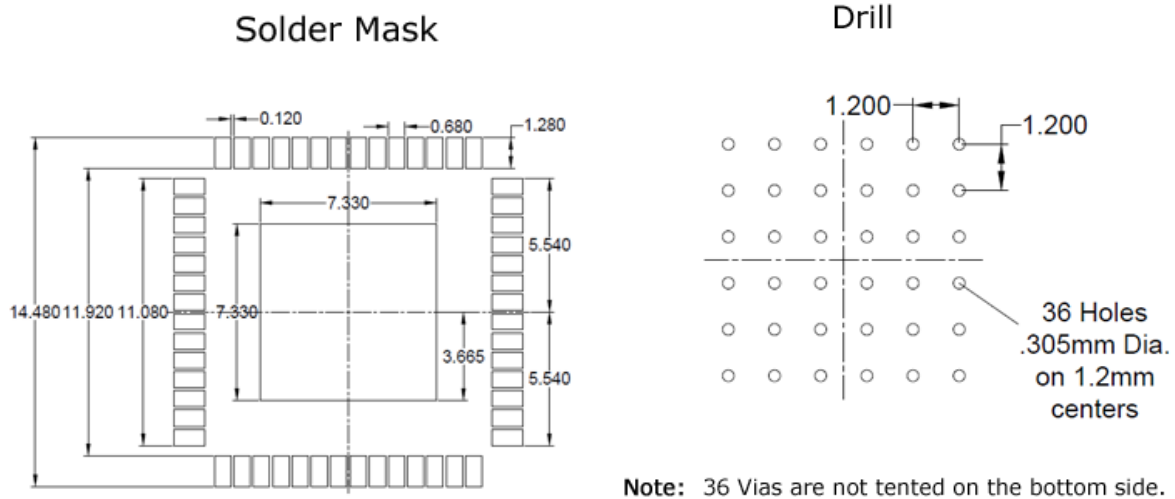

Figure 10: SiP Photo (Bottom View)



Note: The ground pad beneath the SiP (radio) should be the ground plane of your circuit board. The exposed portion of the ground pad beneath the SiP is controlled by the Solder Mask layer.



Note: 36 Vias are not tented on the bottom side.

Mounting

Summit specializes in the design and manufacturing of Wi-Fi radio modules and cards. Although we understand that every system is different, our expertise does not extend to the system level. Because of this, we can provide only integration guidelines and not individual design reviews and approvals.

The SDC-SSD40NBT is a Quad Flat pack with No Leads (QFN) System in Package (SiP). Summit has mounted this device to a PCB with a host and antenna connectors and markets that radio module as the SDC-MSD40NBT.

Note: The following information results from Summit's experience in producing the SDC-MSD40NBT. Summit provides these data for informational purposes only and provides no warranties or claims with regard to the applicability of this information to a particular design.

Solder Stencil Opening for Pads (56 signal pads): 1:1 to 1:0.9 (dependent on solder type)

Solder Stencil Opening for Thermal Pads (9 "window pane" pads): 1:0.5 to 1:0.75 (dependent on solder type)

Note: The vias that are in the thermal pad (6x6 pattern of 12 mil holes) are open; they are not tented by the solder mask on the bottom side. This allows excess paste to escape from the bottom side to help ensure a flat SIP installation.

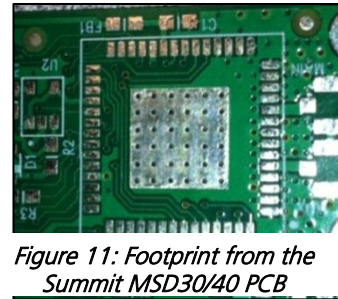

Figure 11: Footprint from the Summit MSD30/40 PCB

Solder Paste Type: No-Clean as the soldered part to board clearance will not allow for adequate post solder cleaning.

Rework is technically challenging due to parts on the SIP reflowing at the same temperature needed for rework. The SDC-SSD40NBT cannot be lifted by the shield during rework. As such, removal of part for rework is not recommended. Reflow without removal has been successfully used to clear shorts found during x-ray inspection.

Reflow: The SDC-SSD40NBT is RoHS compliant and as such is sensitive to heat. The below graphic details a typical profile for such and device and is provided for reference purposes.

Recommendations:

If the SSD40NBT has been removed from the moisture-protective packaging for more than 24 hours, bake at 125 degrees Celsius for 24 hours (per Jedec-STD-033). This is a preparatory step prior to reflow to ensure that the SIPs are sufficiently dehydrated. Reflow should occur immediately following baking to prevent rehydration.

Referred to IPC/JEDEC standard.
Peak Temperature: < 250°C
Number of Times: ≤ 2

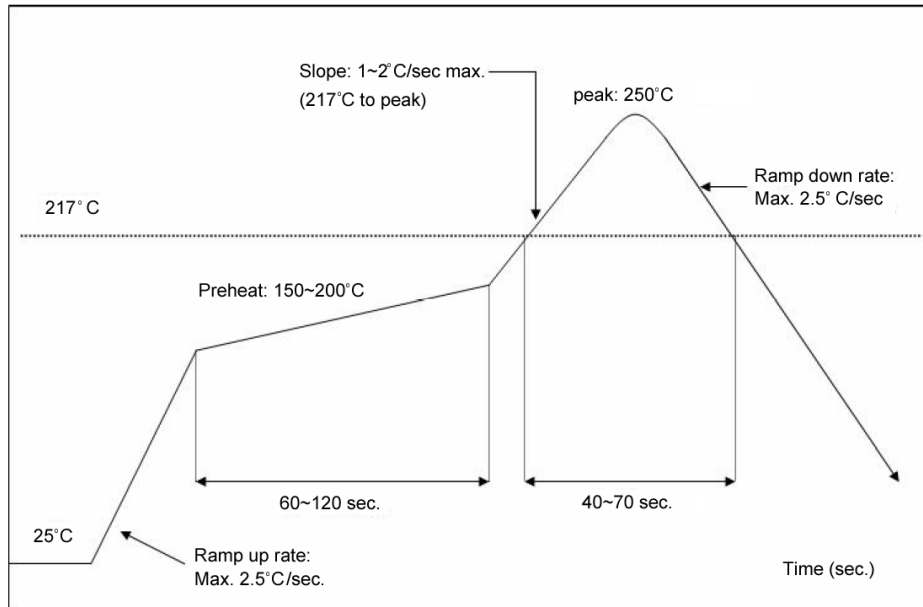

RF LAYOUT DESIGN GUIDELINES

The following is a list of RF layout design guidelines and recommendation when installing a Summit radio into your device.

- Do not run antenna cables directly above or directly below the radio.
- Do not place any parts or run any high speed digital lines below the radio.
- If there are other radios or transmitters located on the device (such as a Bluetooth radio), place the devices as far apart from each other as possible.
- Ensure that there is the maximum allowable spacing separating the antenna connectors on the Summit radio from the antenna. In addition, do not place antennas directly above or directly below the radio.
- Summit recommends the use of a double shielded cable for the connection between the radio and the antenna elements.
- Use proper electro-static-discharge (ESD) procedures when installing the Summit radio module.

REGULATORY

Certified Antennas

The SDC-SSD40NBT was tested to the regulatory standards defined in the "Certifications" section of the Specifications table above. Summit conducted these tests with the following antennas:

Venture

- **Form Factor:** Omni-directional
- **Type:** PCB Internal Antenna
- **Maximum 2.4 GHz Gain:** 2 dBi
- **Tested and Certified 2.4 GHz Transmit Power:** TBD

Cisco AIR-ANT 4941

- **Form Factor:** Whip
- **Type:** Dipole
- **Maximum 2.4 GHz Gain:** 2.2 dBi
- **Tested and Certified 2.4 GHz Transmit Power:** 100% of maximum setting (no reduction of power is required in the 2.4 GHz band)

Radiall Larson Dipole (R380500314)

- **Form Factor:** Whip
- **Type:** Dipole
- **Maximum 2.4 GHz Gain:** 1.6 dBi (not used during testing)
- **Maximum 5 GHz Gain:** 5 dBi
- **Tested and Certified 5 GHz Transmit Power:** 100% of maximum setting (no reduction of power is required in the 5 GHz band)

Antennas of differing types and higher gains may be integrated as well. If necessary, with the Summit Manufacturing Utility software utility, OEMs may reduce the transmit power of the SDC-SSD40NBT to account for higher antenna gain. In some cases, OEMs may be able to reduce certification efforts by using antennas that are of like type and equal or lesser gain to the above listed antennas.

Documentation Requirements

In order to maintain regulatory compliance, when integrating the SDC-SSD40NBT into a host device and leveraging Summit's grants and certifications, it is necessary to meet the documentation requirements set forth by the applicable regulatory agencies. The following sections (FCC, Industry Canada, and European Union) outline the information that may be included in the user's guide and external labels for the host devices into which the SDC-SSD40NBT is integrated.

FCC

Note: You must place "Contains FCC ID: TWG-SDC SSD40NBT" on the host product in such a location that it can be seen by an operator at the time of purchase.

User's Guide Requirements

When integrating the SDC-SSD40NBT into a host device, the integrator must include specific information in the user's guide for the device into which the SDC-SSD40NBT is integrated. The integrator must not provide information to the end user regarding how to install or remove this RF module in the user's manual of the device into which the SDC-SSD40NBT is integrated. The following FCC statements must be added in their entirety and without modification into a prominent place in the user's guide for the device into which the SDC-SSD40NBT is integrated:

Federal Communication Commission Interference Statement

This equipment has been tested and found to comply with the limits for a Class B digital device, pursuant to Part 15 of the FCC Rules. These limits are designed to provide reasonable protection against harmful interference in a residential installation. This equipment generates, uses, and can radiate radio frequency energy and, if not installed and used in accordance with the instructions, may cause harmful interference to radio communications. However, there is no guarantee that interference will not occur in a particular installation. If this equipment does cause harmful interference to radio or television reception, which can be determined by turning the equipment off and on, the user is encouraged to try to correct the interference by one of the following measures:

1. Reorient or relocate the receiving antenna.
2. Increase the separation between the equipment and receiver.
3. Connect the equipment into an outlet on a circuit different from that to which the receiver is connected.
4. Consult the dealer or an experienced radio/TV technician for help.

Note: This device and its antenna(s) must not be co-located or operating in conjunction with any other antenna or transmitter.

FCC Caution: Any changes or modifications not expressly approved by the party responsible for compliance could void the user's authority to operate this equipment.

This device complies with Part 15 of the FCC Rules. Operation is subject to the following two conditions: (1) This device may not cause harmful interference, and (2) this device must accept any interference received, including interference that may cause undesired operation.

IMPORTANT NOTE: FCC Radiation Exposure Statement:

This equipment complies with FCC radiation exposure limits set forth for an uncontrolled environment. This equipment should be installed and operated with minimum distance 20cm between the radiator & your body.

Industry Canada

Note: You must place "Contains IC ID: 6616A-SDC SSD40NBT" on the host product in such a location that it can be seen by an operator at the time of purchase.

User's Guide Requirements (for Model # SDC-SSD40NBT)

Americas: +1-800-492-2320 Option 3

29

Laird Technologies

Europe: +44-1628-858-940

Hong Kong: +852-2268-6567 x026

www.lairdtech.com/wireless

RF Radiation Hazard Warning

To ensure compliance with FCC and Industry Canada RF exposure requirements, this device must be installed in a location where the antennas of the device will have a minimum distance of at least 20 cm from all persons. Using higher gain antennas and types of antennas not certified for use with this product is not allowed. The device shall not be co-located with another transmitter.

Installez l'appareil en veillant à conserver une distance d'au moins 20 cm entre les éléments rayonnants et les personnes. Cet avertissement de sécurité est conforme aux limites d'exposition définies par la norme CNR-102 relative aux fréquences radio.

Maximum Antenna Gain – If the integrator configures the device such that the antenna is detectable from the host product.

This radio transmitter (IC ID: 6616A-SDC SSD40L) has been approved by Industry Canada to operate with the antenna types listed below with the maximum permissible gain and required antenna impedance for each antenna type indicated. Antenna types not included in this list, having a gain greater than the maximum gain indicated for that type, are strictly prohibited for use with this device.

Le présent émetteur radio (IC ID: 6616A-SDC SSD40L) a été approuvé par Industrie Canada pour fonctionner avec les types d'antenne énumérés ci-dessous et ayant un gain admissible maximal et l'impédance requise pour chaque type d'antenne. Les types d'antenne non inclus dans cette liste, ou dont le gain est supérieur au gain maximal indiqué, sont strictement interdits pour l'exploitation de l'émetteur.

Under Industry Canada regulations, this radio transmitter may only operate using an antenna of a type and maximum (or lesser) gain approved for the transmitter by Industry Canada. To reduce potential radio interference to other users, the antenna type and its gain should be so chosen that the equivalent isotropically radiated power (e.i.r.p.) is not more than that necessary for successful communication.

Conformément à la réglementation d'Industrie Canada, le présent émetteur radio peut fonctionner avec une antenne d'un type et d'un gain maximal (ou inférieur) approuvé pour l'émetteur par Industrie Canada. Dans le but de réduire les risques de brouillage radioélectrique à l'intention des autres utilisateurs, il faut choisir le type d'antenne et son gain de sorte que la puissance isotrope rayonnée équivalente (p.i.r.e.) ne dépasse pas l'intensité nécessaire à l'établissement d'une communication satisfaisante.

This device complies with Industry Canada license-exempt RSS standard(s). Operation is subject to the following two conditions: (1) this device may not cause interference, and (2) this device must accept any interference, including interference that may cause undesired operation of the device.

Le présent appareil est conforme aux CNR d'Industrie Canada applicables aux appareils radio exempts de licence. L'exploitation est autorisée aux deux conditions suivantes : (1) l'appareil ne doit pas produire de brouillage, et (2) l'utilisateur de l'appareil doit accepter tout brouillage radioélectrique subi, même si le brouillage est susceptible d'en compromettre le fonctionnement.

European Union

User's Guide Requirements

The integrator must include specific information in the user's guide for the device into which the SDC-SSD40NBT is integrated. In addition to the required FCC and IC statements outlined above, the following R&TTE statements must be added in their entirety and without modification into a prominent place in the user's guide for the device into which the SDC-SSD40NBT is integrated:

This device complies with the essential requirements of the R&TTE Directive 1999/5/EC. The following test methods have been applied in order to prove presumption of conformity with the essential requirements of the R&TTE Directive 1999/5/EC:

- EN60950-1:2001 A11:2004

Safety of Information Technology Equipment

- **EN 300 328 V1.7.1: (2006-10)**
Electromagnetic compatibility and Radio spectrum Matters (ERM); Wideband Transmission systems; Data transmission equipment operating in the 2,4 GHz ISM band and using spread spectrum modulation techniques; Harmonized EN covering essential requirements under article 3.2 of the R&TTE Directive
- **EN 300 328 v1.7.1 (BT 2.1)**
- **EN 301 489-1 V1.6.1: (2005-09)**
Electromagnetic compatibility and Radio Spectrum Matters (ERM); ElectroMagnetic Compatibility (EMC) standard for radio equipment and services; Part 1: Common technical requirements
- **EN 301 489-17 V1.2.1 (2002-08)**
Electromagnetic compatibility and Radio spectrum Matters (ERM); ElectroMagnetic Compatibility (EMC) standard for radio equipment and services; Part 17: Specific conditions for 2,4 GHz wideband transmission systems and 5 GHz high performance RLAN equipment
- **EN 301 893**
Electromagnetic compatibility and Radio spectrum Matters (ERM); Broadband Radio Access Networks (BRAN); Specific conditions for 5 GHz high performance RLAN equipment
- **EU 2002/95/EC (RoHS)**
Declaration of Compliance – EU Directive 2003/95/EC; Reduction of Hazardous Substances (RoHS)

This device is a 2.4 GHz wideband transmission system (transceiver), intended for use in all EU member states and EFTA countries, except in France and Italy where restrictive use applies.

In Italy the end-user should apply for a license at the national spectrum authorities in order to obtain authorization to use the device for setting up outdoor radio links and/or for supplying public access to telecommunications and/or network services.



This device may not be used for setting up outdoor radio links in France and in some areas the RF output power may be limited to 10 mW EIRP in the frequency range of 2454 – 2483.5 MHz. For detailed information the end-user should contact the national spectrum authority in France.

cs [Czech]	<i>[Jméno výrobce]</i> tímto prohlašuje, že tento <i>[typ zařízení]</i> je ve shodě se základními požadavky a dalšími příslušnými ustanoveními směrnice 1999/5/ES.
----------------------	--

da [Danish]	Undertegnede <i>[fabrikantens navn]</i> erklærer herved, at følgende udstyr <i>[udstyrets typebetegnelse]</i> overholder de væsentlige krav og øvrige relevante krav i direktiv 1999/5/EF.
-----------------------	--

de [German]	Hiermit erkläre <i>[Name des Herstellers]</i> , dass sich das Gerät <i>[Gerätetyp]</i> in Übereinstimmung mit den grundlegenden Anforderungen und den übrigen einschlägigen Bestimmungen der Richtlinie 1999/5/EG befindet.
-----------------------	---

et [Estonian]	Käesolevaga kinnitab <i>[tootja nimi = name of manufacturer]</i> seadme <i>[seadme tüüp = type of equipment]</i> vastavust direktiivi 1999/5/EÜ põhinõuetele ja nimetatud direktiivist tulenevatele teistele asjakohastele sätetele.
-------------------------	--

 English	Hereby, <i>[name of manufacturer]</i> , declares that this <i>[type of equipment]</i> is in compliance with the essential requirements and other relevant provisions of Directive 1999/5/EC.
 Español [Spanish]	Por medio de la presente <i>[nombre del fabricante]</i> declara que el <i>[clase de equipo]</i> cumple con los requisitos esenciales y cualesquiera otras disposiciones aplicables o exigibles de la Directiva 1999/5/CE.
 Ελληνική [Greek]	ΜΕ ΤΗΝ ΠΑΡΟΥΣΑ <i>[name of manufacturer]</i> ΔΗΛΩΝΕΙ ΟΤΙ <i>[type of equipment]</i> ΣΥΜΜΟΡΦΩΝΕΤΑΙ ΠΡΟΣ ΤΙΣ ΟΥΣΙΩΔΕΙΣ ΑΠΑΙΤΗΣΕΙΣ ΚΑΙ ΤΙΣ ΛΟΙΠΕΣ ΣΧΕΤΙΚΕΣ ΔΙΑΤΑΞΕΙΣ ΤΗΣ ΟΔΗΓΙΑΣ 1999/5/ΕΚ.
 Français [French]	Par la présente <i>[nom du fabricant]</i> déclare que l'appareil <i>[type d'appareil]</i> est conforme aux exigences essentielles et aux autres dispositions pertinentes de la directive 1999/5/CE.
 Italiano [Italian]	Con la presente <i>[nome del costruttore]</i> dichiara che questo <i>[tipo di apparecchio]</i> è conforme ai requisiti essenziali ed alle altre disposizioni pertinenti stabilite dalla direttiva 1999/5/CE.
Latviski [Latvian]	Ar šo <i>[name of manufacturer / izgatavotāja nosaukums]</i> deklarē, ka <i>[type of equipment / iekārtas tips]</i> atbilst Direktīvas 1999/5/EK būtiskajām prasībām un citiem ar to saistītajiem noteikumiem.
Lietuvių [Lithuanian]	Šiuo <i>[manufacturer name]</i> deklaruoją, kad šis <i>[equipment type]</i> atitinka esminius reikalavimus ir kitas 1999/5/EB Direktyvos nuostatas.
 Nederlands [Dutch]	Hierbij verklaart <i>[naam van de fabrikant]</i> dat het toestel <i>[type van toestel]</i> in overeenstemming is met de essentiële eisen en de andere relevante bepalingen van richtlijn 1999/5/EG.
 Malti [Maltese]	Hawnhekk, <i>[isem tal-manifattur]</i> , jiddikjara li dan <i>[il-mudel tal-prodott]</i> jikkonforma mal-ħtiġijiet essenzjali u ma provvedimenti oħrajn rilevanti li hemm fid-Dirrettiva 1999/5/EC.
 Magyar [Hungarian]	Alulírott, <i>[gyártó neve]</i> nyilatkozom, hogy a <i>[... típus]</i> megfelel a vonatkozó alapvető követelményeknek és az 1999/5/EC irányelv egyéb előírásainak.
 Polski [Polish]	Niniejszym <i>[nazwa producenta]</i> oświadczam, że <i>[nazwa wyrobu]</i> jest zgodny z zasadniczymi wymogami oraz pozostałymi stosownymi postanowieniami Dyrektywy 1999/5/EC.
 Português [Portuguese]	<i>[Nome do fabricante]</i> declara que este <i>[tipo de equipamento]</i> está conforme com os requisitos essenciais e outras disposições da Directiva 1999/5/CE.
 Slovensko [Slovenian]	<i>[Ime proizvajalca]</i> izjavlja, da je ta <i>[tip opreme]</i> v skladu z bistvenimi zahtevami in ostalimi relevantnimi določili direktive 1999/5/ES.

Slovensky [Slovak]	<i>[Meno výrobcu]</i> týmto vyhlasuje, že <i>[typ zariadenia]</i> spĺňa základné požiadavky a všetky príslušné ustanovenia Smernice 1999/5/ES.
[fi]Suomi [Finnish]	<i>[Valmistaja = manufacturer]</i> vakuuttaa täten että <i>[type of equipment = laitteen tyyppimerkintä]</i> tyyppinen laite on direktiivin 1999/5/EY oleellisten vaatimusten ja sitä koskevien direktiivin muiden ehtojen mukainen.
[sv]Svenska [Swedish]	Härmed intygar <i>[företag]</i> att denna <i>[utrustningstyp]</i> står i överensstämmelse med de väsentliga egenskapskrav och övriga relevanta bestämmelser som framgår av direktiv 1999/5/EG.

Labeling Requirements

The final end product must be labeled in a visible area with the following notice:

