

FCC RADIO TEST REPORT

FCC ID: TW8FP-GPCPS6

MEASUREMENT AND TEST REPORT
For

DREAMGEAR, LLC

20001S, Western Avenue, Torrance, CA, United States

Model: DGPS3-3863

29 Sep. 2012

This Report Concerns: <input checked="" type="checkbox"/> Original Report	Equipment Type: GALAXIA wireless controller for PS3
Test Engineer:	<i>Jumy qiu</i>
Report Number:	POCE12093832RF
Test Date:	22 Sep. 2012 ~28 Sep. 2012
Reviewed By:	<i>Ada Li</i>
Prepared By:	Shenzhen POCE Technology Co., Ltd. Room 501-502, Bldg. 1, Xinghua Garden, Bao'an Road, Xixiang, Bao'an District, Shenzhen, Guangdong, China Tel: 86-755-2911 3252 Fax: 86-755-2911 3135

TEST RESULT CERTIFICATION

Applicant's name : DREAMGEAR, LLC

Address : 20001S, Western Avenue, Torrance, CA, United States

Manufacturer's Name : Fortune Power Electronic Technology Co., Ltd.

Address : 11-4F., No. 163, Sec. 5, Nan King E. Rd., Taipei 105, Taiwan

Product description

Product name..... : GALAXIA wireless controller for PS3

Model and/or type reference : DGPS3-3863

Standards : FCC Part15.249

Test procedure ANSI C63.4-2003

This device described above has been tested by NTEK, and the test results show that the equipment under test (EUT) is in compliance with the FCC requirements. And it is applicable only to the tested sample identified in the report.

This report shall not be reproduced except in full, without the written approval of NTEK, this document may be altered or revised by NTEK, personal only, and shall be noted in the revision of the document.

Date of Test :

Date (s) of performance of tests..... : 22 Sep. 2012 ~28 Sep. 2012

Date of Issue..... : 29 Sep. 2012

Test Result..... : **Pass**

Table of Contents

Page

1 . SUMMARY OF TEST RESULTS	4
1.1 TEST FACILITY	5
1.2 MEASUREMENT UNCERTAINTY	5
2 . GENERAL INFORMATION	6
2.1 GENERAL DESCRIPTION OF EUT	6
2.2 DESCRIPTION OF TEST MODES	7
2.3 BLOCK DIGRAM SHOWING THE CONFIGURATION OF SYSTEM TESTED	8
2.4 DESCRIPTION OF SUPPORT UNITS(CONDUCTED MODE)	9
2.5 EQUIPMENTS LIST FOR ALL TEST ITEMS	10
3 . TEST RESULT	11
3.1 ANTENNA REQUIREMENT	11
3.1.1 STANDARD REQUIREMENT	11
3.1.2 EUT ANTENNA	11
3.2 CONDUCTED EMISSION MEASUREMENT	12
3.2.1 POWER LINE CONDUCTED EMISSION LIMITS	12
3.2.2 TEST PROCEDURE	13
3.2.3 DEVIATION FROM TEST STANDARD	13
3.2.4 TEST SETUP	13
3.2.5 TEST RESULT	14
3.3 RADIATED EMISSION MEASUREMENT	16
3.3.1 RADIATED EMISSION LIMITS	16
3.3.2 TEST PROCEDURE	17
3.3.3 DEVIATION FROM TEST STANDARD	17
3.3.4 TEST SETUP	17
3.3.5 TEST RESULTS (BLOW 30MHZ)	19
3.3.6 TEST RESULTS (BETWEEN 30 – 1000 MHZ)	20
3.3.7 TEST RESULTS (ABOVE 1000 MHZ)	22
4 . BANDWIDTH TEST	32
4.1 TEST PROCEDURE	32
4.2 DEVIATION FROM STANDARD	32
4.3 TEST SETUP	32
4.4 TEST RESULTS	33
5 . EUT TEST PHOTO	35
APPENDIX-PHOTOGRAPHS OF EUT CONSTRUCTIONAL DETAILS	

1. SUMMARY OF TEST RESULTS

Test procedures according to the technical standards:

FCC Part15, Subpart C (15.249)			
Standard Section	Test Item	Judgment	Remark
15.207	Conducted Emission	Pass	
15.203	Antenna Requirement	Pass	
15.249	Radiated Spurious Emission	Pass	
15.249	Occupied Bandwidth	Pass	

1.1 TEST FACILITY

NTEK Testing Technology Co., Ltd

Add. : 1/F, Building E, Fenda Science Park, Sanwei Community, Xixiang Street, Bao'an District, Shenzhen P.R. China.

FCC Registration Nombre:238937; IC Registration Nombre:9270A-1

1.2 MEASUREMENT UNCERTAINTY

The reported uncertainty of measurement $y \pm U$, where expanded uncertainty U is based on a standard uncertainty multiplied by a coverage factor of $k=2$, providing a level of confidence of approximately **95 %**.

No.	Item	Uncertainty
1	Conducted Emission Test	$\pm 1.38\text{dB}$
2	RF power,conducted	$\pm 0.16\text{dB}$
3	Spurious emissions,conducted	$\pm 0.21\text{dB}$
4	All emissions,radiated(<1G)	$\pm 4.68\text{dB}$
5	All emissions,radiated(>1G)	$\pm 4.89\text{dB}$
6	Temperature	$\pm 0.5^\circ\text{C}$
7	Humidity	$\pm 2\%$

2. GENERAL INFORMATION

2.1 GENERAL DESCRIPTION OF EUT

Equipment	GALAXIA wireless controller for PS3	
Trade Name	N/A	
Model Name	DGPS3-3863	
OEM Brand/Model Name	N/A	
Product Description	The EUT is a GALAXIA wireless controller for PS3	
	Operation Frequency:	2405~2476 MHz
	Modulation Type:	GFSK
	Antenna Designation:	PCB board
	Antenna Gain(Peak)	0 dBi
	EIRP	85.24dbuv/m@3m(AV Max)
	Based on the application, features, or specification exhibited in User's Manual, the EUT is considered as an ITE/Computing Device. More details of EUT technical specification, please refer to the User's Manual.	
Adapter	N/A	
Battery	Rated Voltage: 3.7V	
	Charge Limit: 4.2V	

Note:

1. For a more detailed features description, please refer to the manufacturer's specifications or the User's Manual.
- 2.

Table for Filed Antenna

Ant	Brand	Model Name	Antenna Type	Connector	Gain (dBi)	NOTE
1	N/A	N/A	onboard	NA	0	Antenna

2.2 DESCRIPTION OF TEST MODES

To investigate the maximum EMI emission characteristics generates from EUT, the test system was pre-scanning tested base on the consideration of following EUT operation mode or test configuration mode which possible have effect on EMI emission level. Each of these EUT operation mode(s) or test configuration mode(s) mentioned above was evaluated respectively.

Pretest Mode	Description
Mode 1	CH Lower
Mode 2	CH Mid
Mode 3	CH Higher

For Conducted Emission	
Final Test Mode	Description
Mode 4	charging

For Radiated Emission	
Final Test Mode	Description
Mode 1	CH Lower
Mode 2	CH Mid
Mode 3	CH Higher

Note:

- (1) The measurements are performed at the highest, middle, lowest available channels.
- (2) The EUT use new battery.

2.3 BLOCK DIGRAM SHOWING THE CONFIGURATION OF SYSTEM TESTED

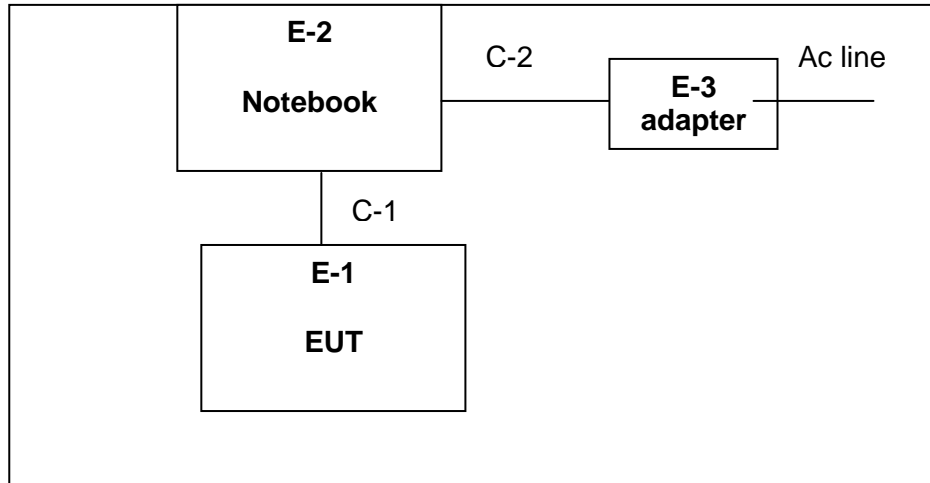

2.4 DESCRIPTION OF SUPPORT UNITS

The EUT has been tested as an independent unit together with other necessary accessories or support units. The following support units or accessories were used to form a representative test configuration during the tests.

Item	Equipment	Mfr/Brand	Model/Type No.	Series No.	Note
E-1	GALAXIA wireless controller for PS3	N/A	DGPS3-3863	N/A	EUT
E-2	Notebook	IBM	2366	N/A	
E-3	Adapter	IBM	A1367	C23DW5T5DCP7	

Item	Shielded Type	Ferrite Core	Length	Note
C-1	NO	NO	80cm	
C-2	NO	YES	100cm	

Note:

- (1) The support equipment was authorized by Declaration of Confirmation.
- (2) For detachable type I/O cable should be specified the length in cm in 『Length』 column.

2.5 EQUIPMENTS LIST FOR ALL TEST ITEMS

Radiation Test equipment

Item	Kind of Equipment	Manufacturer	Type No.	Serial No.	Calibrated until
1	Spectrum Analyzer	Agilent	E4407B	160400005	Jul. 06. 2013
2	Test Receiver	R&S	ESPI	101318	Jul. 06. 2013
3	Bilog Antenna	TESEQ	CBL6111D	31216	Jul. 06. 2013
4	50Ω Coaxial Switch	Anritsu	MP59B	6200264416	Jul. 06. 2013
5	Spectrum Analyzer	ADVANTEST	R3132	150900201	Jul. 06. 2013
6	Horn Antenna	EM	EM-AH-10180	2011071402	Jul. 06. 2013
7	Horn Ant	Schwarzbeck	BBHA 9170	9170-181	Jul. 06. 2013
8	Amplifier	EM	EM-30180	060538	Jul. 06. 2013
9	Loop Antenna	ARA	PLA-1030/B	1029	Jul. 06. 2013
10	Power Meter	R&S	NRVS	100696	Jul. 06. 2013

Conduction Test equipment

Item	Kind of Equipment	Manufacturer	Type No.	Serial No.	Calibrated until
1	Test Receiver	R&S	ESCI	101160	Jul. 06. 2013
2	LISN	R&S	ENV216	101313	Jul. 06. 2013
3	LISN	EMCO	3816/2	00042990	Jul. 06. 2013
4	50Ω Coaxial Switch	Anritsu	MP59B	6200264417	Jul. 06. 2013
5	Passive Voltage Probe	R&S	ESH2-Z3	100196	Jul. 06. 2013
6	Absorbing clamp	R&S	MOS-21	100423	Jul. 06. 2013

3. TEST RESULT

3.1 ANTENNA REQUIREMENT

3.1.1 STANDARD REQUIREMENT

15.203 requirement: For intentional device, according to 15.203: an intentional radiator shall be designed to ensure that no antenna other than that furnished by the responsible party shall be used with the device.

3.1.2 EUT ANTENNA

The EUT antenna is integral Antenna. It comply with the standard requirement.

3.2 CONDUCTED EMISSION MEASUREMENT

3.2.1 POWER LINE CONDUCTED EMISSION Limits (Frequency Range 150KHz-30MHz)

FREQUENCY (MHz)	Class A (dBuV)		Class B (dBuV)		Standard
	Quasi-peak	Average	Quasi-peak	Average	
0.15 -0.5			66 - 56 *	56 - 46 *	CISPR
0.50 -5.0			56.00	46.00	CISPR
5.0 -30.0			60.00	50.00	CISPR

0.15 -0.5			66 - 56 *	56 - 46 *	LP002.
0.50 -5.0			56.00	46.00	LP002.
5.0 -30.0			60.00	50.00	LP002.

Note:

- (1) The tighter limit applies at the band edges.
- (2) The limit of " * " marked band means the limitation decreases linearly with the logarithm of the frequency in the range.

The following table is the setting of the receiver

Receiver Parameters	Setting
Attenuation	10 dB
Start Frequency	0.15 MHz
Stop Frequency	30 MHz
IF Bandwidth	9 kHz

3.2.2 TEST PROCEDURE

- a. The EUT was placed 0.4 meters from the horizontal ground plane with EUT being connected to the power mains through a line impedance stabilization network (LISN). All other support equipments powered from additional LISN(s). The LISN provide 50 Ohm/ 50uH of coupling impedance for the measuring instrument.
- b. Interconnecting cables that hang closer than 40 cm to the ground plane shall be folded back and forth in the center forming a bundle 30 to 40 cm long.
- c. I/O cables that are not connected to a peripheral shall be bundled in the center. The end of the cable may be terminated, if required, using the correct terminating impedance. The overall length shall not exceed 1 m.
- d. LISN at least 80 cm from nearest part of EUT chassis.
- e. For the actual test configuration, please refer to the related Item –EUT Test Photos.

3.2.3 DEVIATION FROM TEST STANDARD

No deviation

3.2.4 TEST SETUP

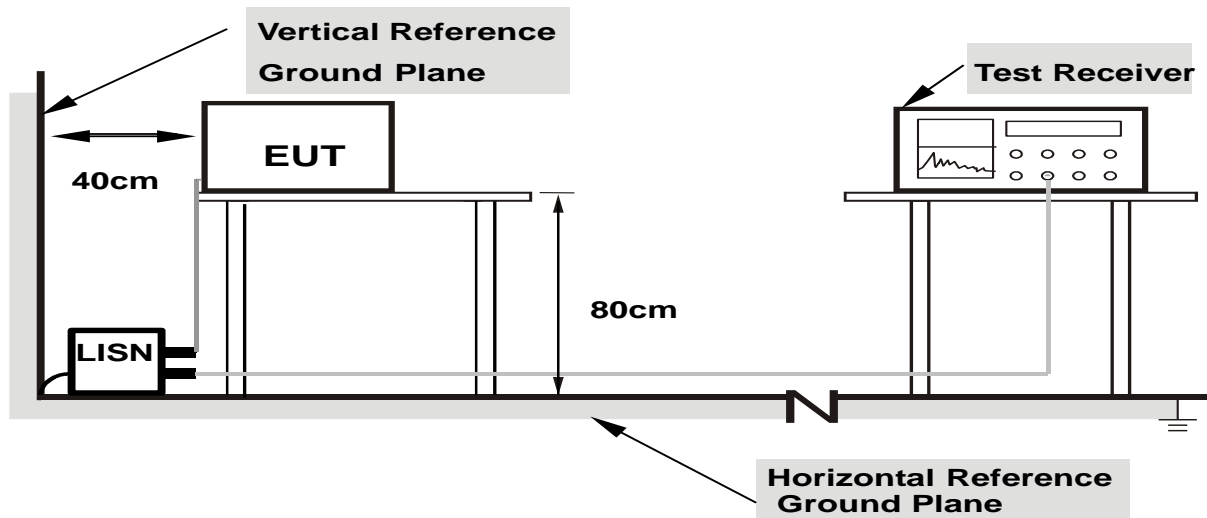

Note: 1.Support units were connected to second LISN.

2.Both of LISNs (AMN) are 80 cm from EUT and at least 80 from other units and other metal planes

3.2.5 TEST RESULT

EUT :	GALAXIA wireless controller for PS3	Model Name. :	DGPS3-3863
Temperature :	20 °C	Relative Humidity :	48%
Pressure :	1010 hPa	Test Voltage :	DC 5V from PC AC 120V/60Hz
Test Mode :	Charging	Polarization :	L

Frequency (MHz)	Meter Reading (dBμV)	Factor (dB)	Emission Level (dBμV)	Limits (dBμV)	Margin (dB)	Detector Type
0.374	36.35	10.42	46.77	58.41	-11.64	QP
0.386	30.05	10.42	40.47	48.15	-7.68	AVG
4.5579	38.89	10.64	49.53	56	-6.47	QP
4.6419	29.6	10.64	40.24	46	-5.76	AVG

Remark:

1. All readings are Quasi-Peak and Average values.
2. Factor = Insertion Loss + Cable Loss.

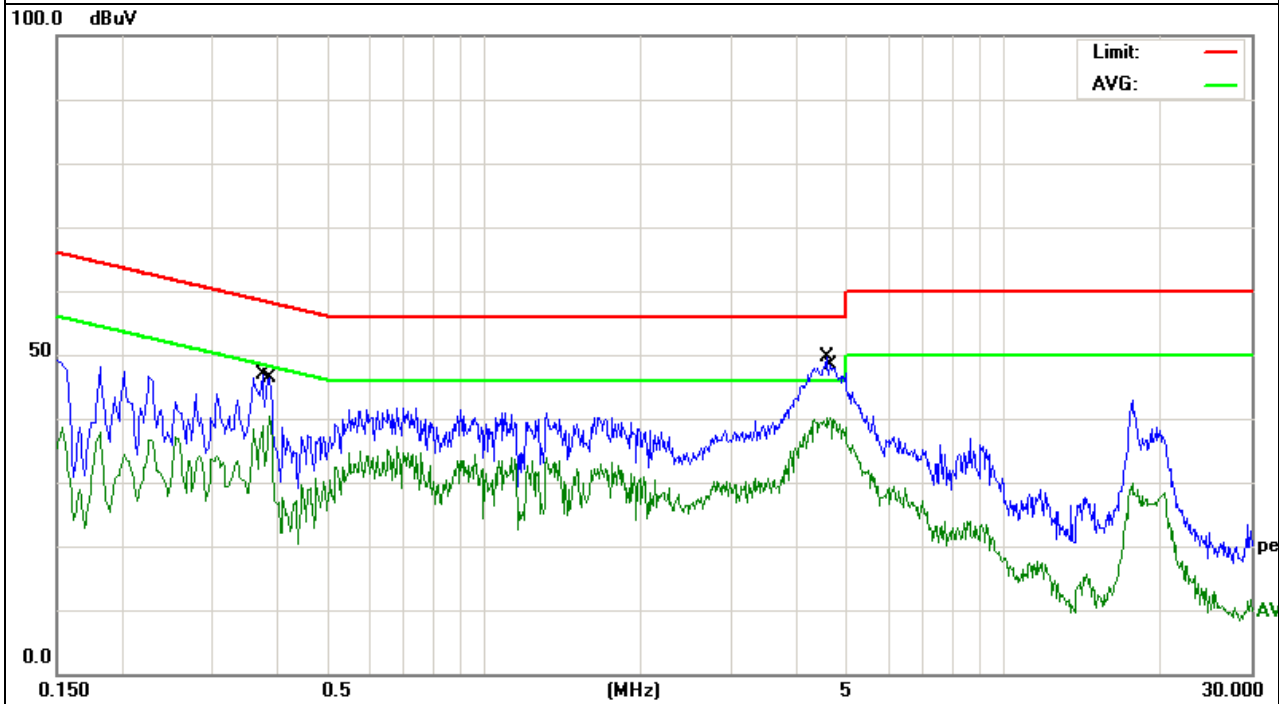

EUT :	GALAXIA wireless controller for PS3	Model Name. :	DGPS3-3863
Temperature :	20 °C	Relative Humidity :	48%
Pressure :	1010 hPa	Test Voltage :	DC 5V from PC AC 120V/60Hz
Test Mode :	Charging	Polarization :	N

Frequency (MHz)	Meter Reading (dBμV)	Factor (dB)	Emission Level (dBμV)	Limits (dBμV)	Margin (dB)	Detector Type
0.37	37.41	10.42	47.83	58.5	-10.67	QP
0.374	29.65	10.42	40.07	48.41	-8.34	AVG
4.353	36.84	10.66	47.5	56	-8.5	QP
4.353	27.64	10.66	38.3	46	-7.7	AVG

Remark:

1. All readings are Quasi-Peak and Average values.
2. Factor = Insertion Loss + Cable Loss.

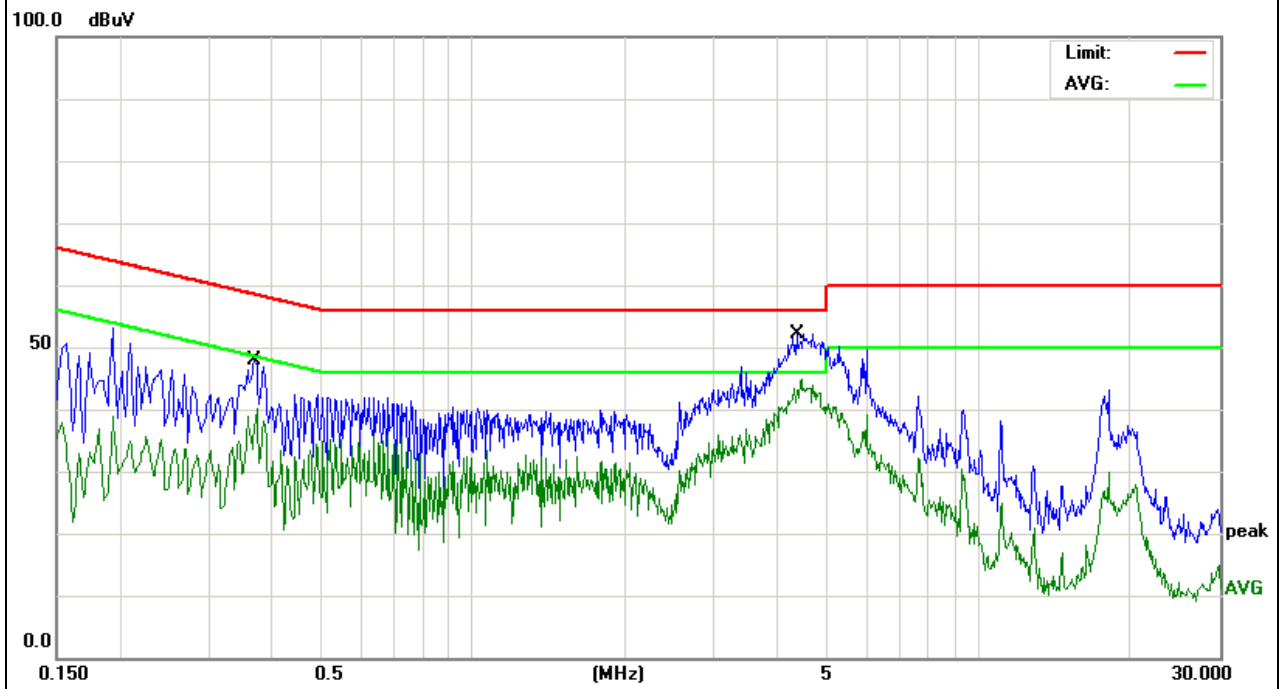

3.3 RADIATED EMISSION MEASUREMENT

3.3.1 Radiated Emission Limits (FCC 15.209)

Frequencies (MHz)	Field Strength (microvolts/meter)	Measurement Distance (meters)
0.009~0.490	2400/F(KHz)	300
0.490~1.705	24000/F(KHz)	30
1.705~30.0	30	30
30~88	100	3
88~216	150	3
216~960	200	3
Above 960	500	3

Note:

- (1) The tighter limit applies at the band edges.
- (2) Emission level (dBuV/m)=20log Emission level (uV/m).

LIMITS OF RADIATED EMISSION MEASUREMENT (FCC 15.249)

Frequency of Emission (MHz)	Field Strength of fundamental ((millivolts /meter)	Field Strength of Harmonics (microvolts/meter)
2400 - 2483.5	50	500

Notes:

- (1) Emissions radiated outside of the specified frequency bands, except for harmonics, shall be attenuated by at least 50 dB below the level of the fundamental or to the general radiated emission limits in Section 15.209, whichever is the lesser attenuation.

Spectrum Parameter	Setting
Attenuation	Auto
Start Frequency	1000 MHz
Stop Frequency	10th carrier harmonic
RB / VB (emission in restricted band)	1MHz / 1MHz for Peak

Receiver Parameter	Setting
Attenuation	Auto
Start ~ Stop Frequency	9kHz~150kHz / RB 200Hz for QP
Start ~ Stop Frequency	150kHz~30MHz / RB 9kHz for QP
Start ~ Stop Frequency	30MHz~1000MHz / RB 120kHz for QP

3.3.2 TEST PROCEDURE

- a. The measuring distance of at 3 m shall be used for measurements at frequency up to 1GHz. For frequencies above 1GHz, any suitable measuring distance may be used.
- b. The EUT was placed on the top of a rotating table 0.8 meters above the ground at a 3m meter open area test site. The table was rotated 360 degrees to determine the position of the highest radiation.
- c. The height of the equipment or of the substitution antenna shall be 0.8 m; the height of the test antenna shall vary between 1 m to 4 m.
- d. The initial step in collecting conducted emission data is a spectrum analyzer peak detector mode pre-scanning the measurement frequency range. Significant peaks are then marked and then Quasi Peak detector mode re-measured.
- e. If the Peak Mode measured value compliance with and lower than Quasi Peak Mode Limit, the EUT shall be deemed to meet QP Limits and then no additional QP Mode measurement performed.
- f. For the actual test configuration, please refer to the related Item –EUT Test Photos.

Note:

Both horizontal and vertical antenna polarities were tested and performed pretest to three orthogonal axis. The worst case emissions were reported

3.3.3 DEVIATION FROM TEST STANDARD

No deviation

3.3.4 TEST SETUP

(A) Radiated Emission Test-Up Frequency Below 30MHz

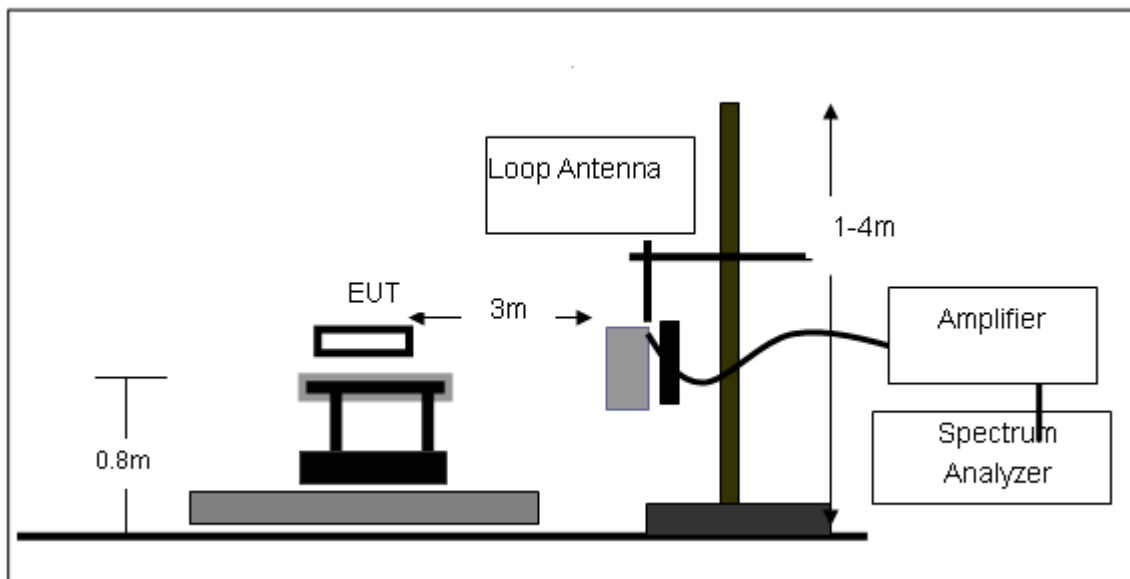

(B) Radiated Emission Test-Up Frequency 30MHz~1GHz

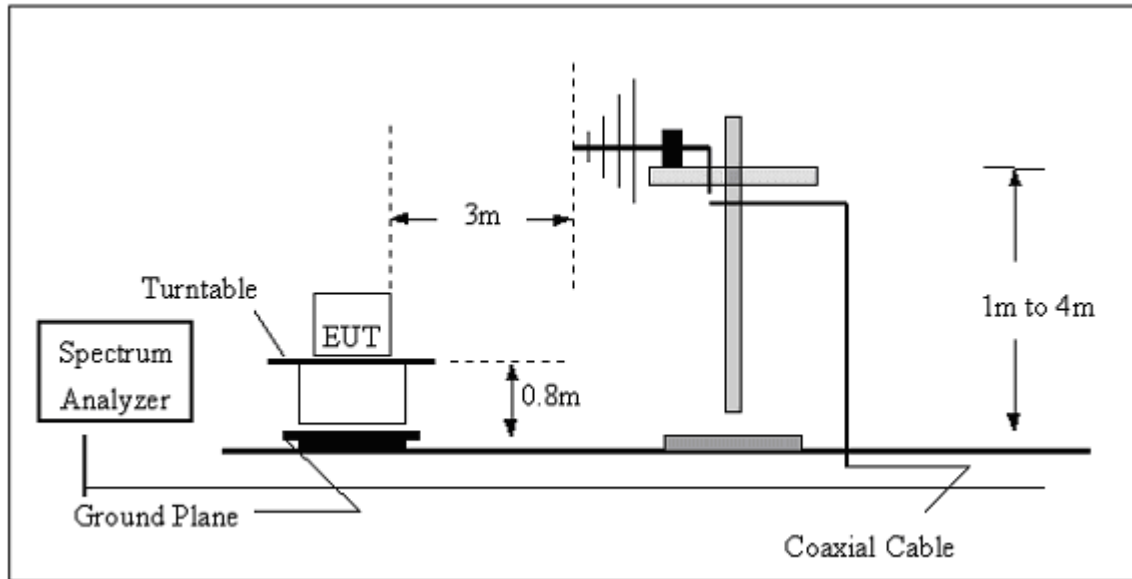

(C) Radiated Emission Test-Up Frequency Above 1GHz

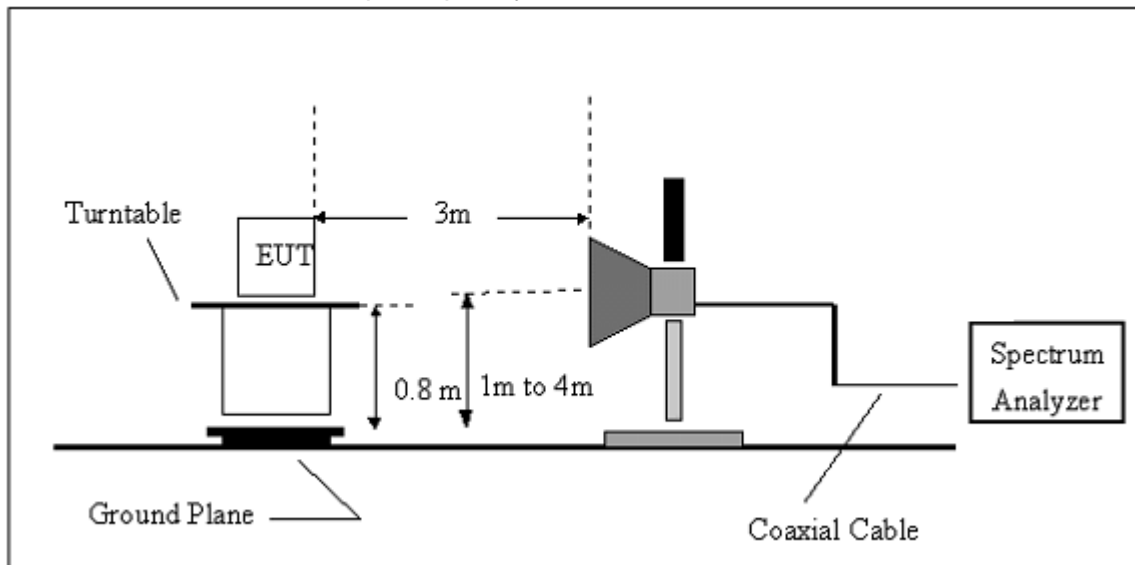

3.3.5 TEST RESULTS (BLOW 30MHz)

EUT :	GALAXIA wireless controller for PS3	Model Name. :	DGPS3-3863
Temperature :	20 °C	Relative Humidity :	48%
Pressure :	1010 hPa	Test Voltage :	DC 3.7V
Test Mode :	TX	Polarization :	--

Freq. (MHz)	Reading (dBuV/m)	Limit (dBuV/m)	Margin (dB)	State P/F
--	--	--	--	PASS
--	--	--	--	PASS

NOTE:

The amplitude of spurious emissions which are attenuated by more than 20dB below the permissible value has no need to be reported.

Distance extrapolation factor = $20 \log (\text{specific distance}/\text{test distance})(\text{dB})$;

Limit line = specific limits(dBuv) + distance extrapolation factor.

3.3.6 TEST RESULTS (BETWEEN 30 – 1000 MHZ)

EUT :	GALAXIA wireless controller for PS3	Model Name :	DGPS3-3863
Temperature :	20 °C	Relative Humidity :	48%
Pressure :	1010 hPa	Test Voltage :	DC 3.7V
Test Mode :	TX	Polarization :	Vertical

Frequency (MHz)	Meter Reading (dBµV)	Factor (dB)	Emission Level (dBµV/m)	Limits (dBµV/m)	Margin (dB)	Detector Type
143.8293	28.33	11.93	40.26	43.5	-3.24	QP
191.745	30.84	8.72	39.56	43.5	-3.94	QP

Remark:
Factor = Antenna Factor + Cable Loss – Pre-amplifier.

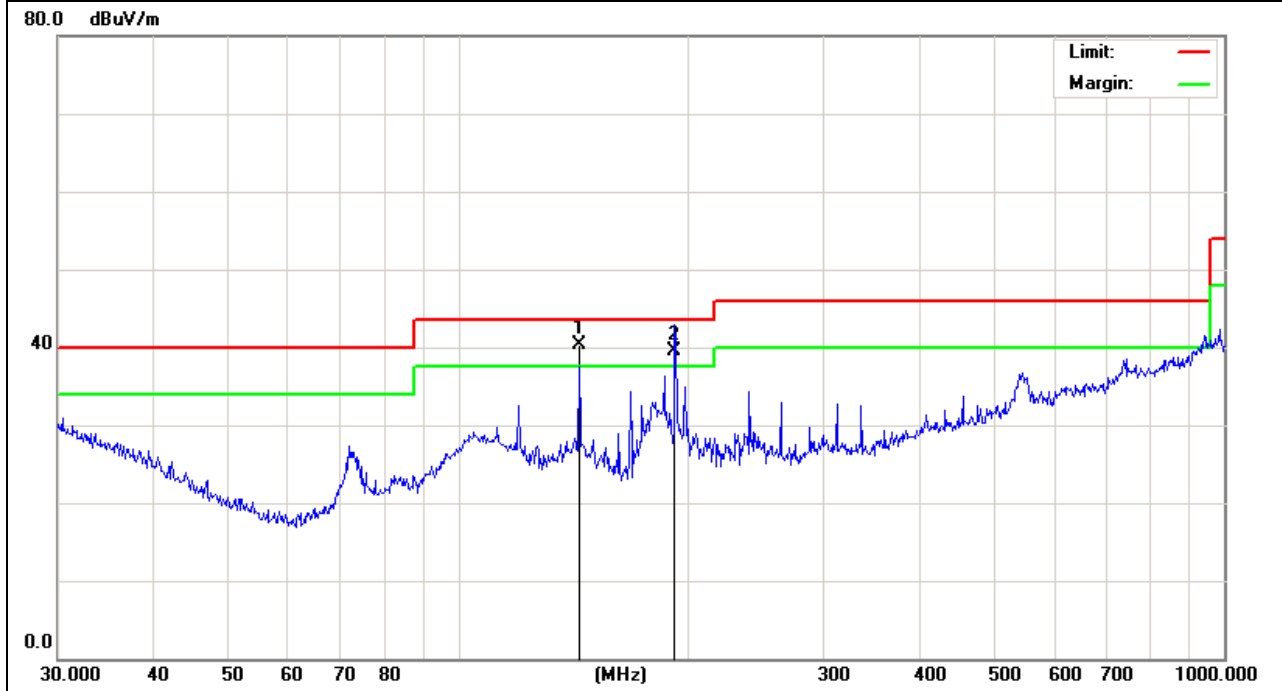

EUT :	GALAXIA wireless controller for PS3	Model Name :	DGPS3-3863
Temperature :	20 °C	Relative Humidity :	48%
Pressure :	1010 hPa	Test Voltage :	DC 3.7V
Test Mode :	TX	Polarization :	Horizontal

Frequency (MHz)	Meter Reading (dBµV)	Factor (dB)	Emission Level (dBµV/m)	Limits (dBµV/m)	Margin (dB)	Detector Type
191.745	30.43	8.72	39.15	43.5	-4.35	QP
263.819	26.04	13.99	40.03	46	-5.97	QP

Remark:

Factor = Antenna Factor + Cable Loss – Pre-amplifier.

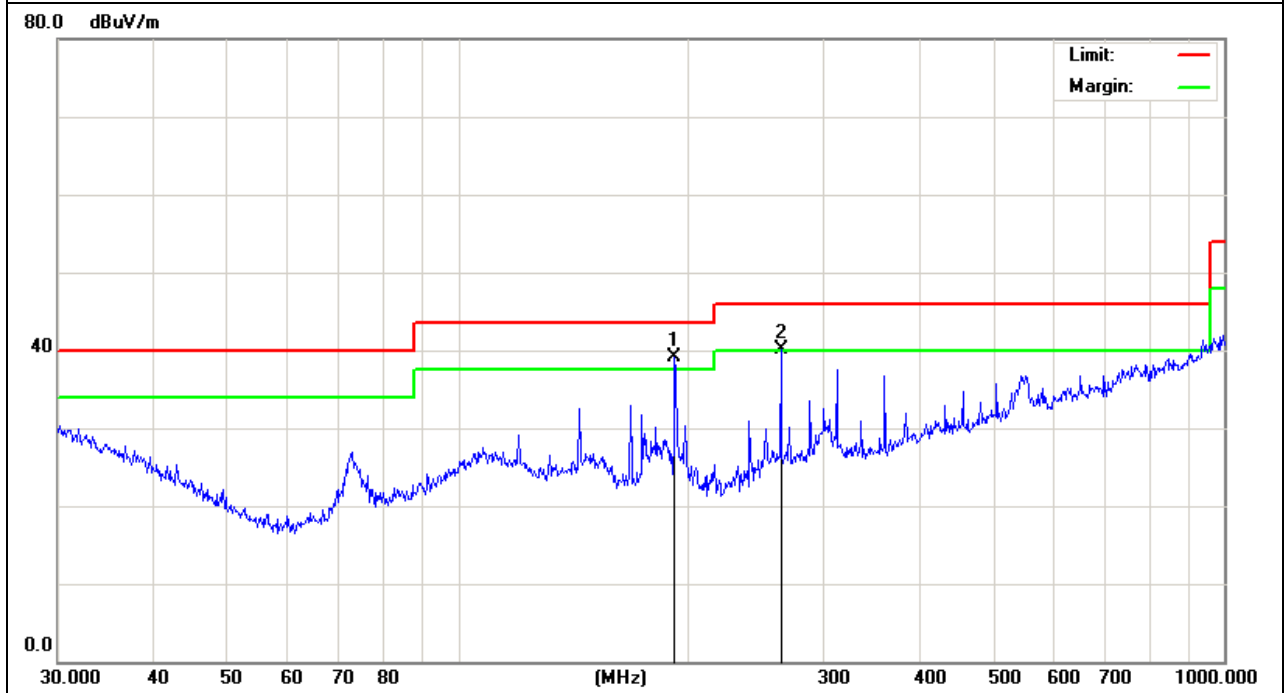

3.3.7 TEST RESULTS (ABOVE 1000 MHZ)

EUT :	GALAXIA wireless controller for PS3	Model Name :	DGPS3-3863
Temperature :	20 °C	Relative Humidity :	48%
Pressure :	1010 hPa	Test Voltage :	DC 3.7V
Test Mode :	TX /2405MHz	Polarization :	Horizontal

Frequency (MHz)	Meter Reading (dBμV)	Factor (dB)	Emission Level (dBμV/m)	Limits (dBμV/m)	Margin (dB)	Detector Type
2405	100.25	-9.97	90.28	114.0 0	-23.72	peak
2405	95.21	-9.97	85.24	94	-8.76	AVG
4810	52.07	2.56	54.63	74	-19.37	peak
4810	46.98	2.56	49.54	54	-4.46	AVG
7215	45.28	4.6	49.88	74	-24.12	peak
7215	40.27	4.6	44.87	54	-9.13	AVG

Remark:
Factor = Antenna Factor + Cable Loss – Pre-amplifier.

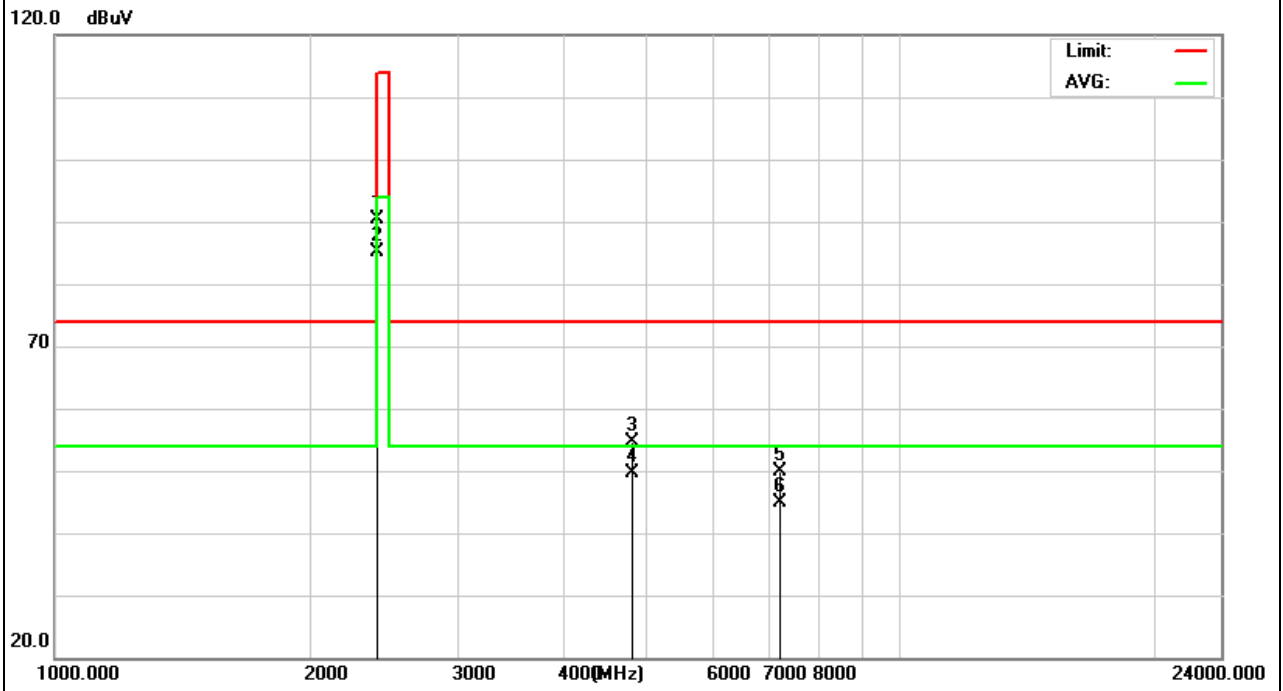

EUT :	GALAXIA wireless controller for PS3	Model Name :	DGPS3-3863
Temperature :	20 °C	Relative Humidity :	48%
Pressure :	1010 hPa	Test Voltage :	DC 3.7V
Test Mode :	TX /2405MHz	Polarization :	Vertical

Frequency (MHz)	Meter Reading (dBμV)	Factor (dB)	Emission Level (dBμV/m)	Limits (dBμV/m)	Margin (dB)	Detector Type
2405	90.11	-9.97	80.14	114.0 0	-33.86	peak
2405	85.21	-9.97	75.24	94	-18.76	AVG
4810	45.15	2.56	47.71	74	-26.29	peak
4810	39.91	2.56	42.47	54	-11.53	AVG
7215	45.23	4.6	49.83	74	-24.17	peak
7215	41.21	4.6	45.81	54	-8.19	AVG

Remark:
Factor = Antenna Factor + Cable Loss – Pre-amplifier.

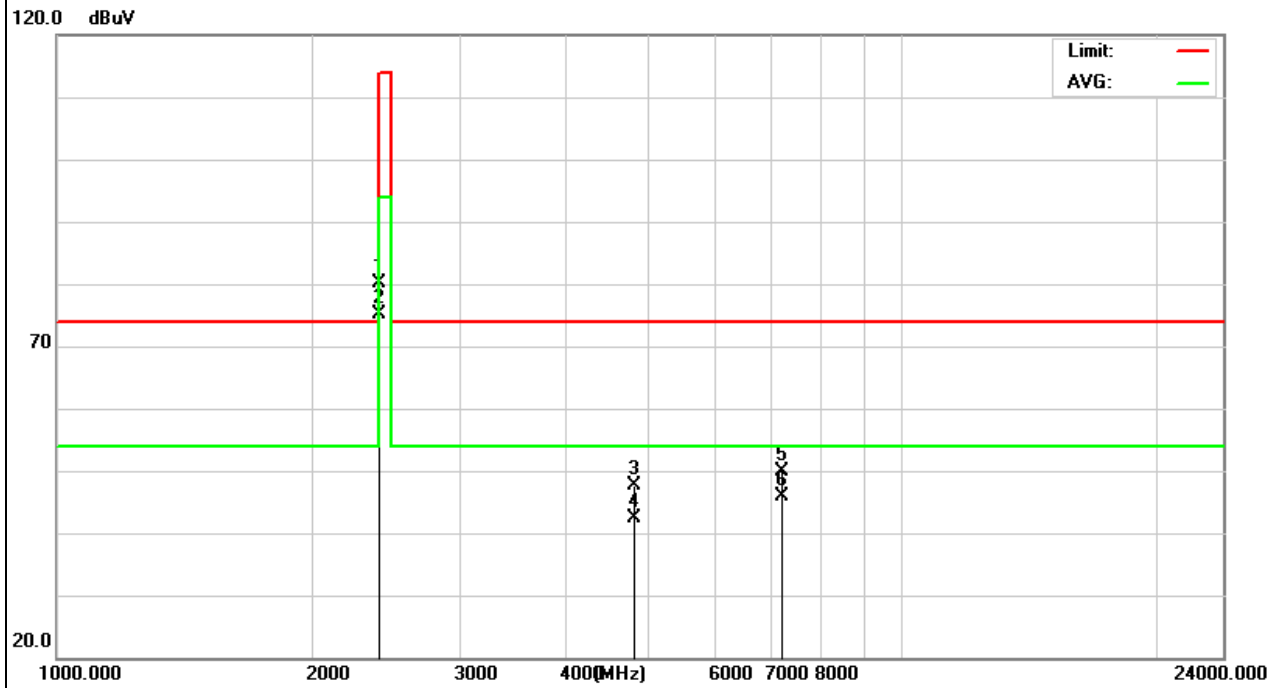

EUT :	GALAXIA wireless controller for PS3	Model Name :	DGPS3-3863
Temperature :	20 °C	Relative Humidity :	48%
Pressure :	1010 hPa	Test Voltage :	DC 3.7V
Test Mode :	TX /2441MHz	Polarization :	Horizontal

Frequency (MHz)	Meter Reading (dBµV)	Factor (dB)	Emission Level (dBµV/m)	Limits (dBµV/m)	Margin (dB)	Detector Type
2441	98.27	-9.91	88.36	114.0 0	-25.64	peak
2441	92.34	-9.91	82.43	94	-11.57	AVG
4882	48.25	2.57	50.82	74	-23.18	peak
4882	43.22	2.57	45.79	54	-8.21	AVG

Remark:
Factor = Antenna Factor + Cable Loss – Pre-amplifier.

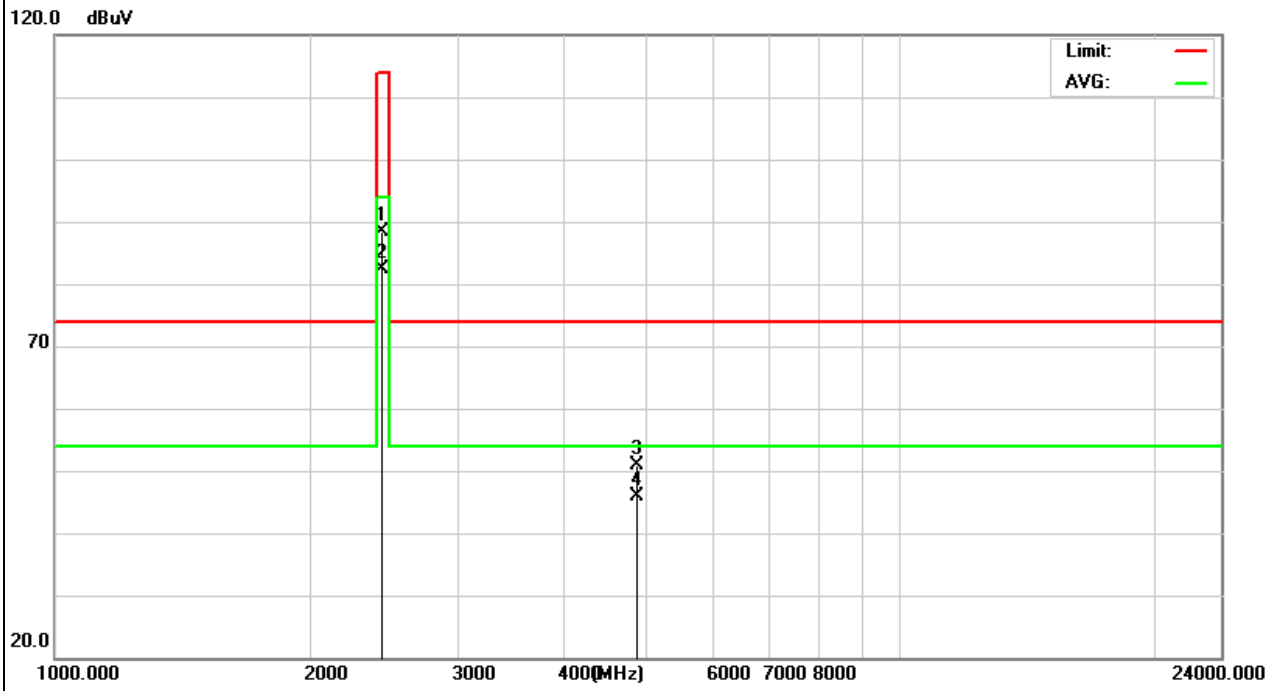

EUT :	GALAXIA wireless controller for PS3	Model Name :	DGPS3-3863
Temperature :	20 °C	Relative Humidity :	48%
Pressure :	1010 hPa	Test Voltage :	DC 3.7V
Test Mode :	TX /2441MHz	Polarization :	Vertical

Frequency (MHz)	Meter Reading (dBµV)	Factor (dB)	Emission Level (dBµV/m)	Limits (dBµV/m)	Margin (dB)	Detector Type
2441	93.67	-9.91	83.76	114.00	-30.24	peak
2441	87.14	-9.91	77.23	94	-16.77	AVG
4882	43.69	2.57	46.26	74	-27.74	peak
4882	38.08	2.57	40.65	54	-13.35	AVG

Remark:
Factor = Antenna Factor + Cable Loss – Pre-amplifier.



EUT :	GALAXIA wireless controller for PS3	Model Name :	DGPS3-3863
Temperature :	20 °C	Relative Humidity :	48%
Pressure :	1010 hPa	Test Voltage :	DC 3.7V
Test Mode :	TX /2476MHz	Polarization :	Horizontal

Frequency (MHz)	Meter Reading (dBµV)	Factor (dB)	Emission Level (dBµV/m)	Limits (dBµV/m)	Margin (dB)	Detector Type
2476	99.25	-9.78	89.47	114.0 0	-24.53	peak
2476	93.06	-9.78	83.28	94	-10.72	AVG
4952	46.48	2.79	49.27	74	-24.73	peak
4952	42.39	2.79	45.18	54	-8.82	AVG

Remark:
Factor = Antenna Factor + Cable Loss – Pre-amplifier.



EUT :	GALAXIA wireless controller for PS3	Model Name :	DGPS3-3863
Temperature :	20 °C	Relative Humidity :	48%
Pressure :	1010 hPa	Test Voltage :	DC 3.7V
Test Mode :	TX /2476MHz	Polarization :	Vertical

Frequency (MHz)	Meter Reading (dBµV)	Factor (dB)	Emission Level (dBµV/m)	Limits (dBµV/m)	Margin (dB)	Detector Type
2476	92.15	-9.78	82.37	114.0 0	-31.63	peak
2476	86.05	-9.78	76.27	94	-17.73	AVG
4952	42.48	2.79	45.27	74	-28.73	peak
4952	38.31	2.79	41.1	54	-12.9	AVG

Remark:
Factor = Antenna Factor + Cable Loss – Pre-amplifier.

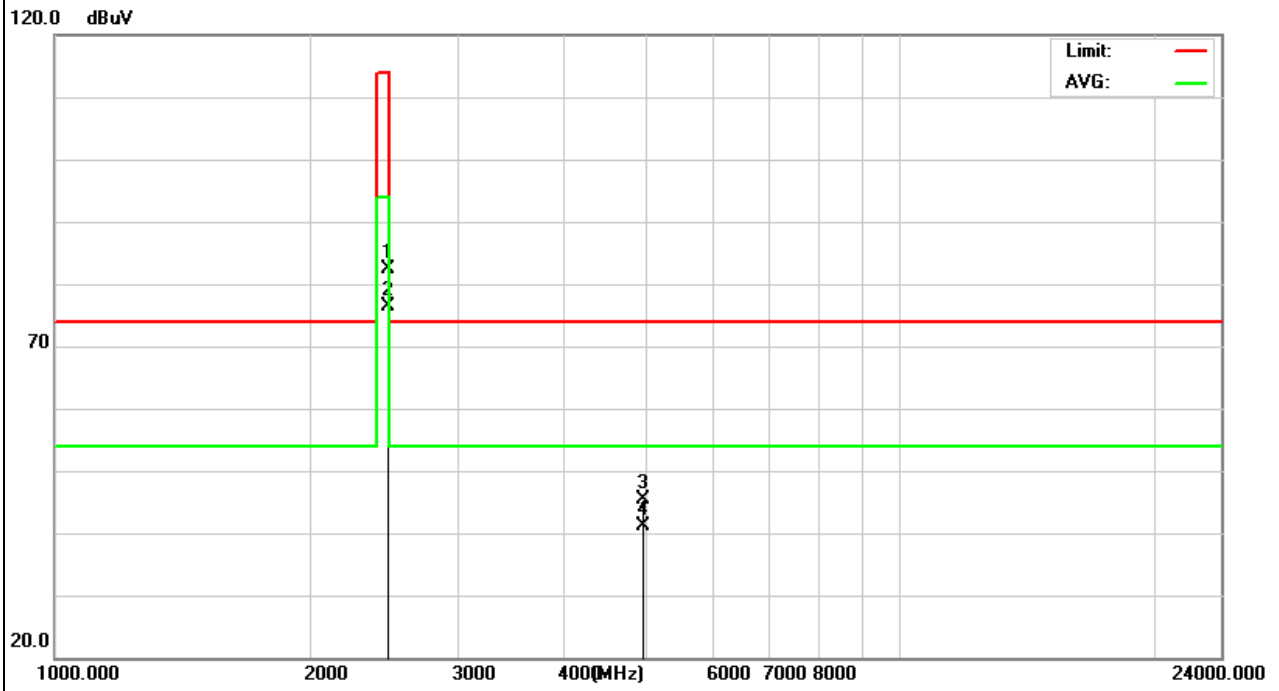

Band Edge Emission:

EUT :	GALAXIA wireless controller for PS3	Model Name :	DGPS3-3863
Temperature :	20 °C	Relative Humidity :	48%
Pressure :	1010 hPa	Test Voltage :	DC 3.7V
Test Mode :	TX /2405MHz	Polarization :	Vertical

Frequency (MHz)	Meter Reading (dBµV)	Factor (dB)	Emission Level (dBµV/m)	Limits (dBµV/m)	Margin (dB)	Detector Type
2400	23.7	35	58.7	74	-15.3	peak
2400	12.18	35	47.18	54	-6.82	AVG

Remark:
Factor = Antenna Factor + Cable Loss – Pre-amplifier.

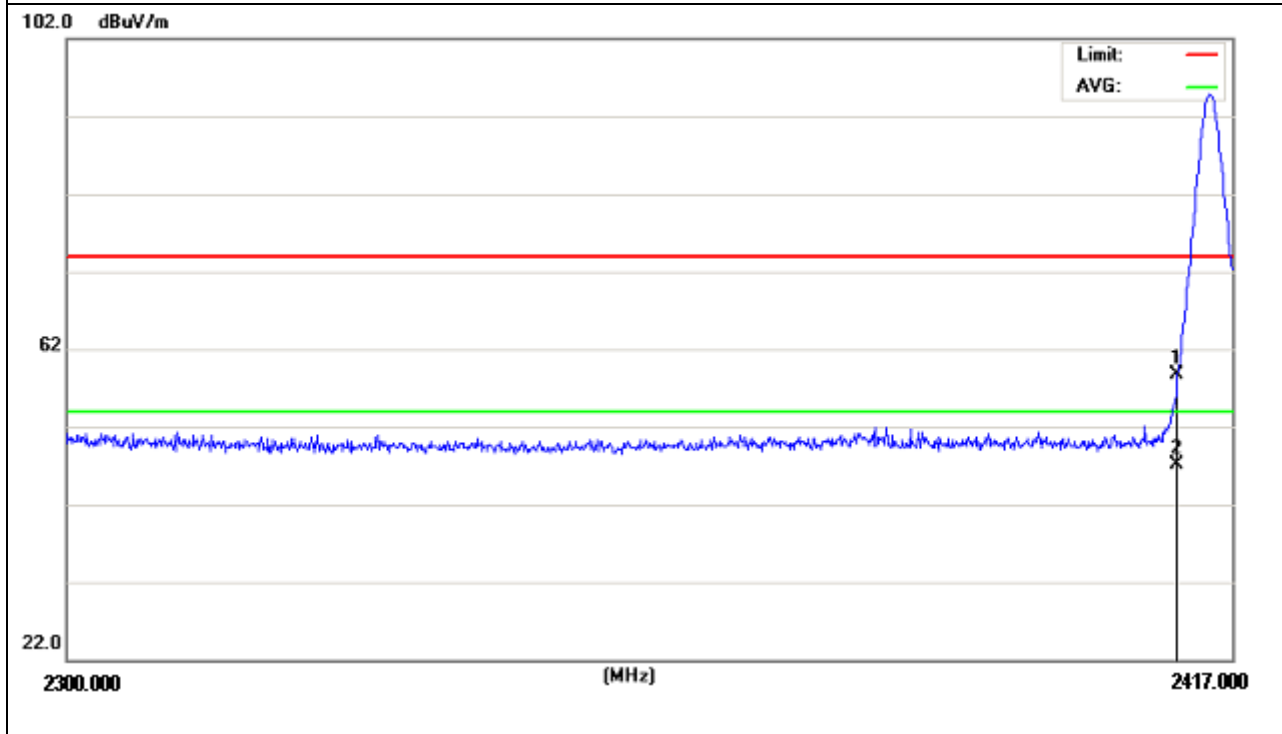

EUT :	GALAXIA wireless controller for PS3	Model Name :	DGPS3-3863
Temperature :	20 °C	Relative Humidity :	48%
Pressure :	1010 hPa	Test Voltage :	DC 3.7V
Test Mode :	TX /2405MHz	Polarization :	Horizontal

Frequency (MHz)	Meter Reading (dBμV)	Factor (dB)	Emission Level (dBμV/m)	Limits (dBμV/m)	Margin (dB)	Detector Type
2400	22.35	35	57.35	74	-16.65	peak
2400	12.09	35	47.09	54	-6.91	AVG

Remark:
Factor = Antenna Factor + Cable Loss – Pre-amplifier.

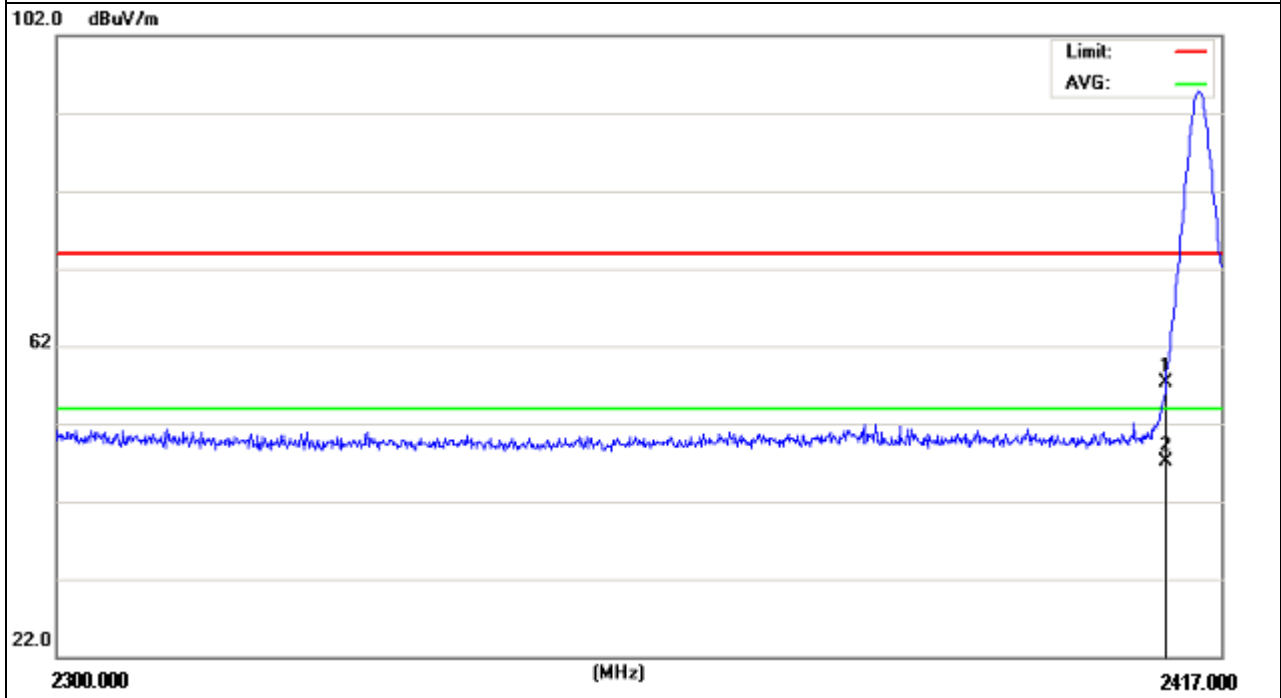

EUT :	GALAXIA wireless controller for PS3	Model Name :	DGPS3-3863
Temperature :	20 °C	Relative Humidity :	48%
Pressure :	1010 hPa	Test Voltage :	DC 3.7V
Test Mode :	TX /2476MHz	Polarization :	Vertical

Frequency (MHz)	Meter Reading (dBµV)	Factor (dB)	Emission Level (dBµV/m)	Limits (dBµV/m)	Margin (dB)	Detector Type
2483.5	16.37	35.25	51.62	74	-22.38	peak
2483.5	6.48	35.25	41.73	54	-12.27	AVG

Remark:
 Factor = Antenna Factor + Cable Loss – Pre-amplifier.

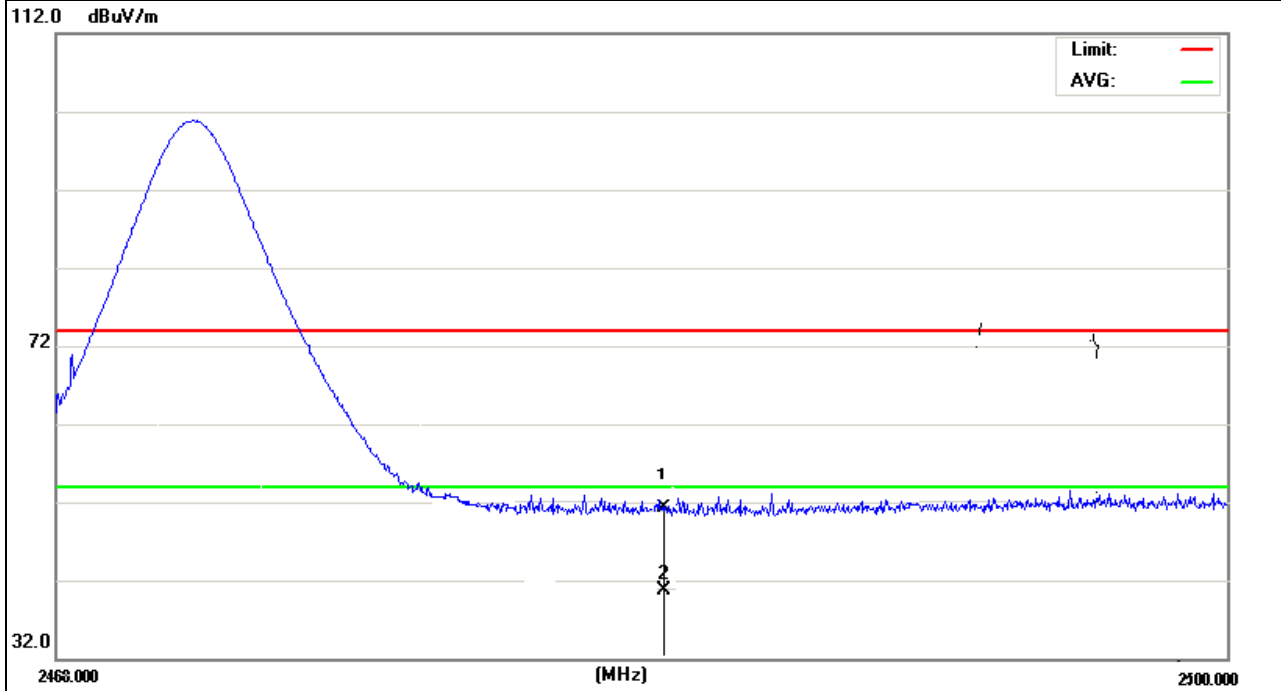

EUT :	GALAXIA wireless controller for PS3	Model Name :	DGPS3-3863
Temperature :	20 °C	Relative Humidity :	48%
Pressure :	1010 hPa	Test Voltage :	DC 3.7V
Test Mode :	TX /2476MHz	Polarization :	Horizontal

Frequency (MHz)	Meter Reading (dBµV)	Factor (dB)	Emission Level (dBµV/m)	Limits (dBµV/m)	Margin (dB)	Detector Type
2483.5	17.15	35.25	52.4	74	-21.6	peak
2483.5	5.98	35.25	41.23	54	-12.77	AVG

Remark:
 Factor = Antenna Factor + Cable Loss – Pre-amplifier.

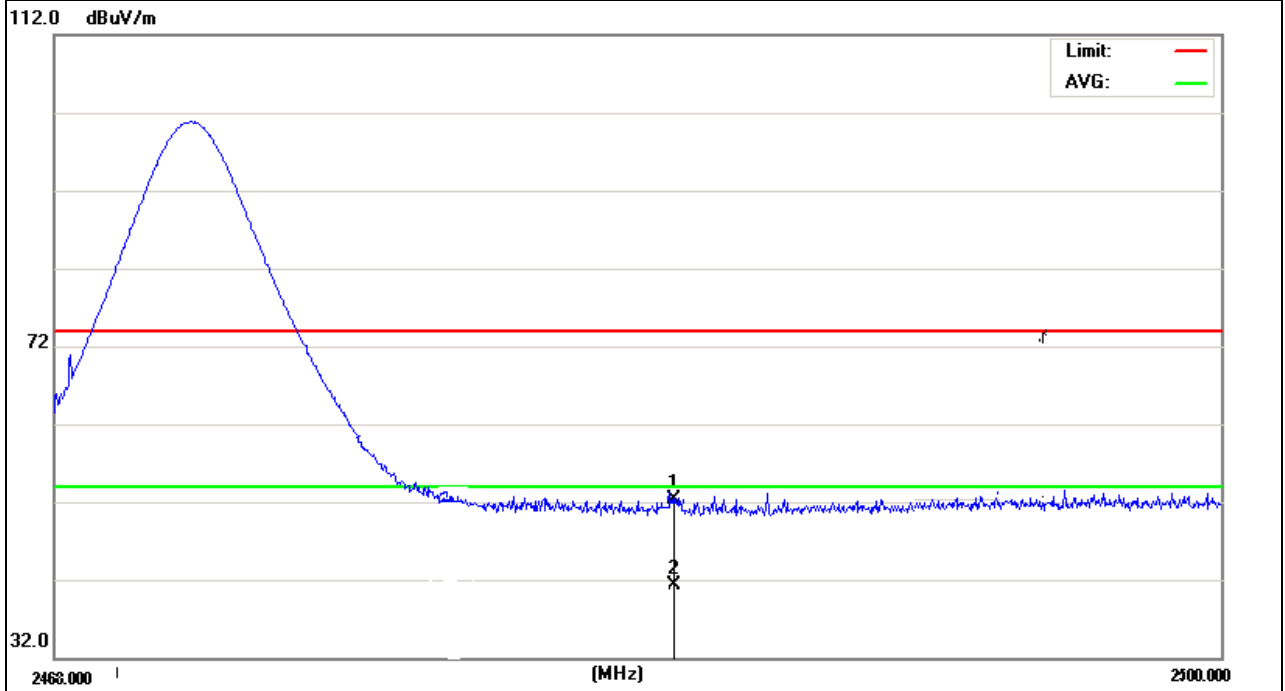

4. BANDWIDTH TEST

4.1 TEST PROCEDURE

- a. The EUT was directly connected to the spectrum analyzer and antenna output port as show in the block diagram below,
- b. Spectrum Setting : RBW= 100KHz, VBW \geq RBW, Sweep time = Auto.

4.2 DEVIATION FROM STANDARD

No deviation.

4.3 TEST SETUP



4.4 TEST RESULTS

EUT :	GALAXIA wireless controller for PS3	Model Name :	DGPS3-3863
Temperature :	26 °C	Relative Humidity :	53%
Pressure :	1020 hPa	Test Power :	DC 3.7V
Test Mode :	TX		

Test Channel	Frequency (MHz)	20 dBc Bandwidth (MHz)
CH Low	2405	1.045
CH Mid	2441	1.065
CH High	2476	1.086

The High Channel:2405MHz

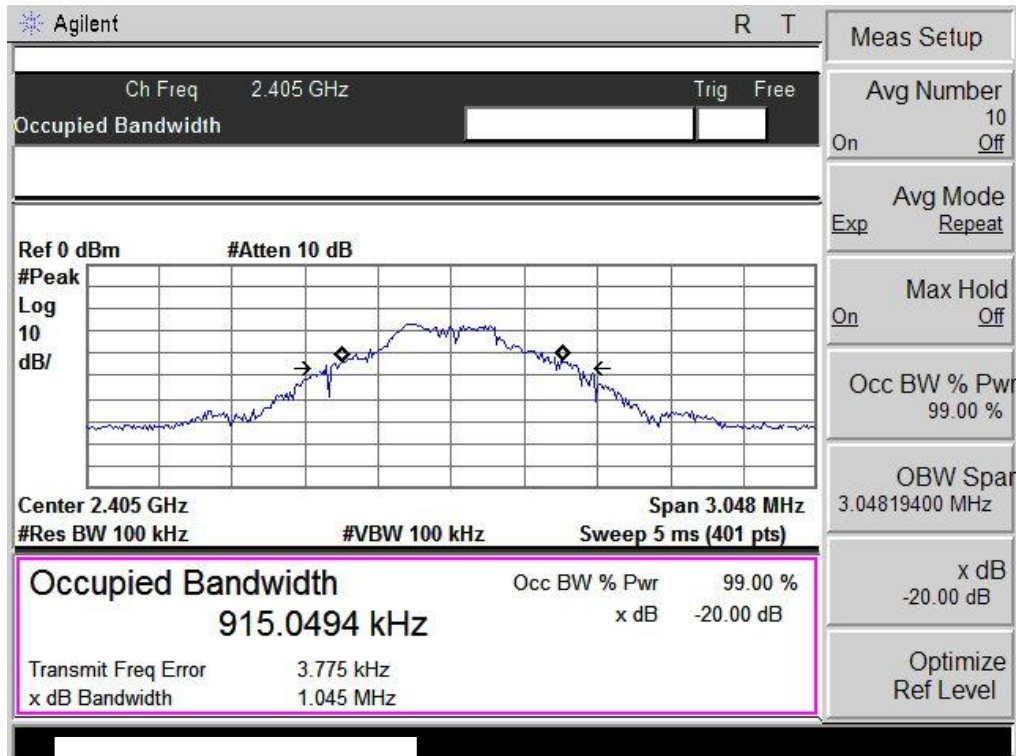

The Lowest Channel: 24441MHz

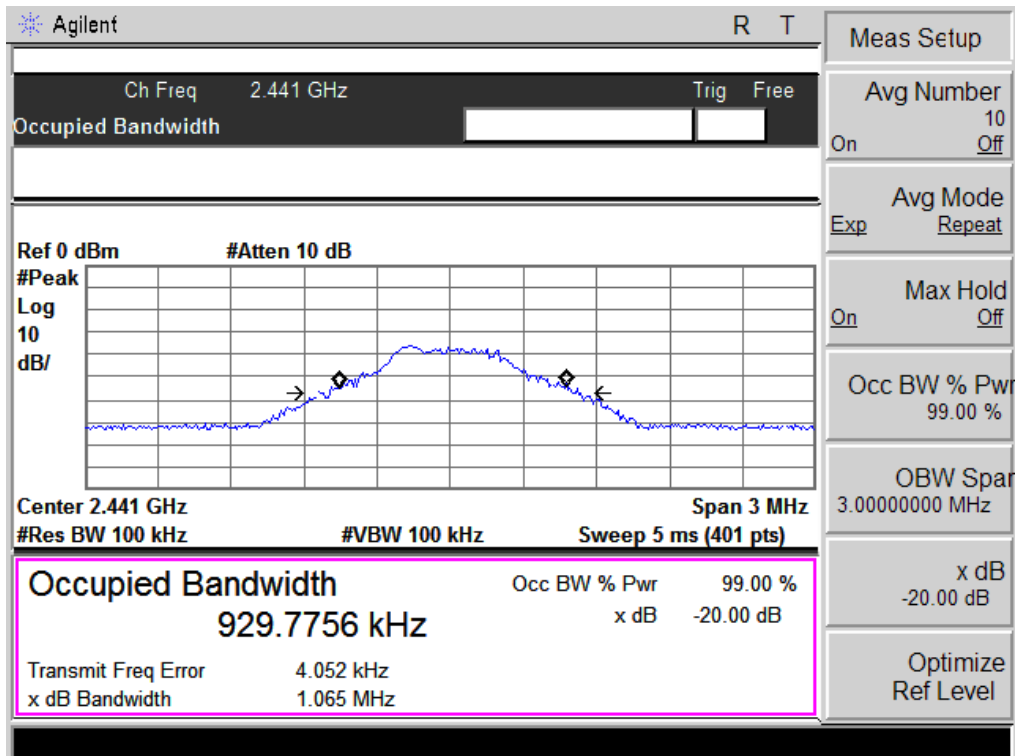

The Middle Channel: 2476MHz

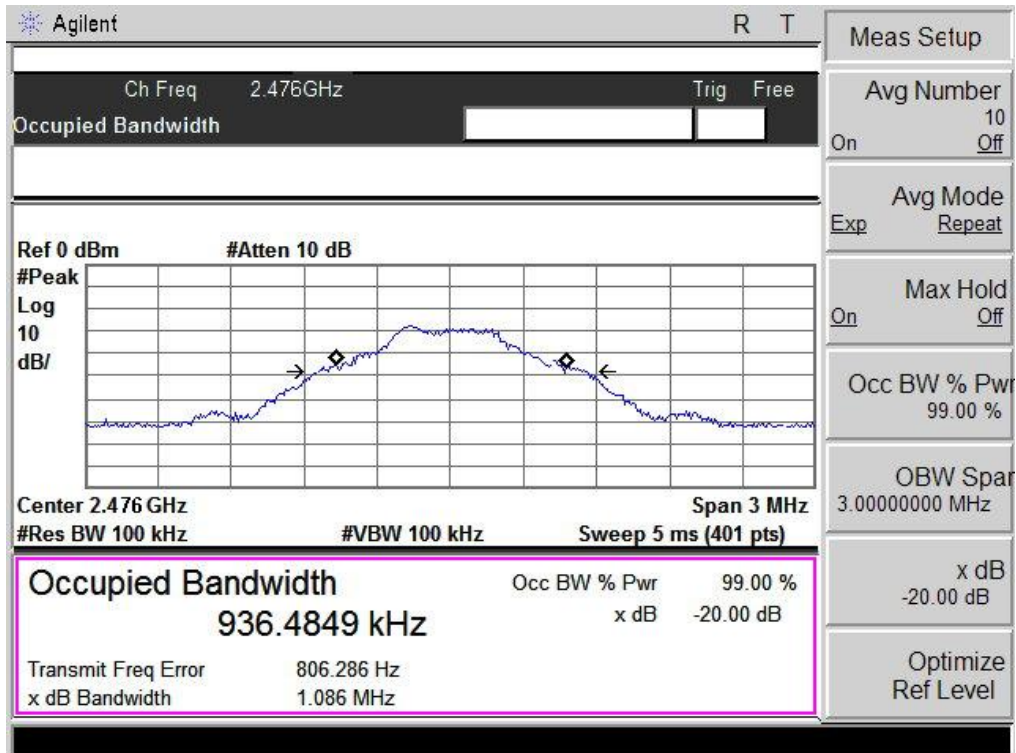

5. EUT TEST PHOTO

Radiated Measurement Photos

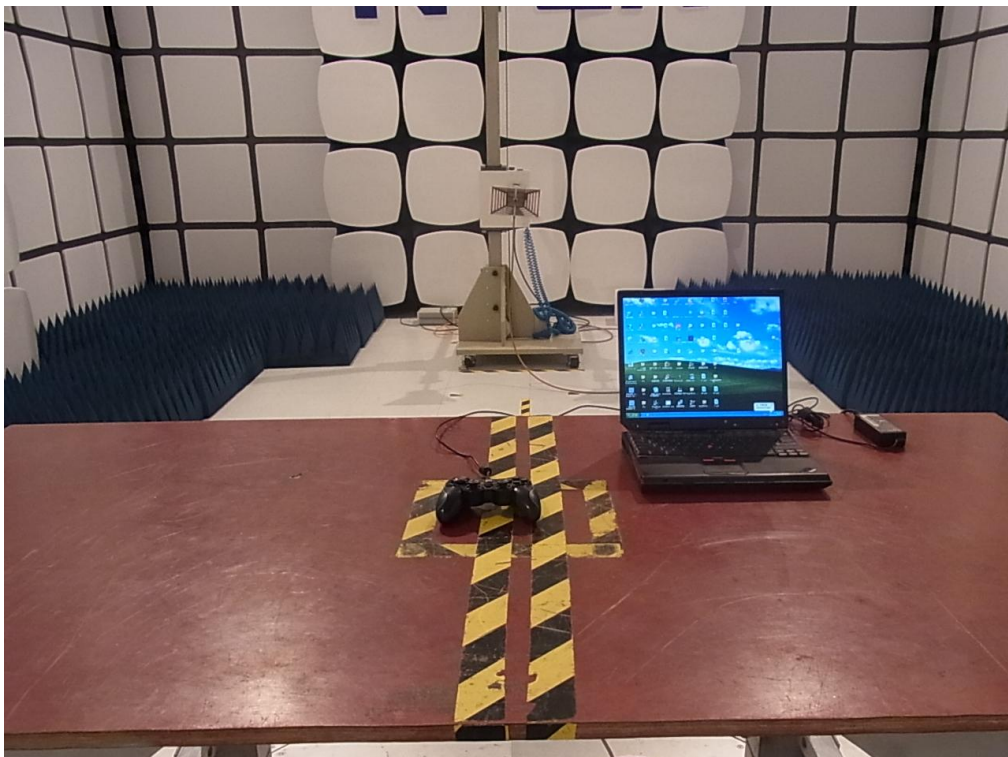
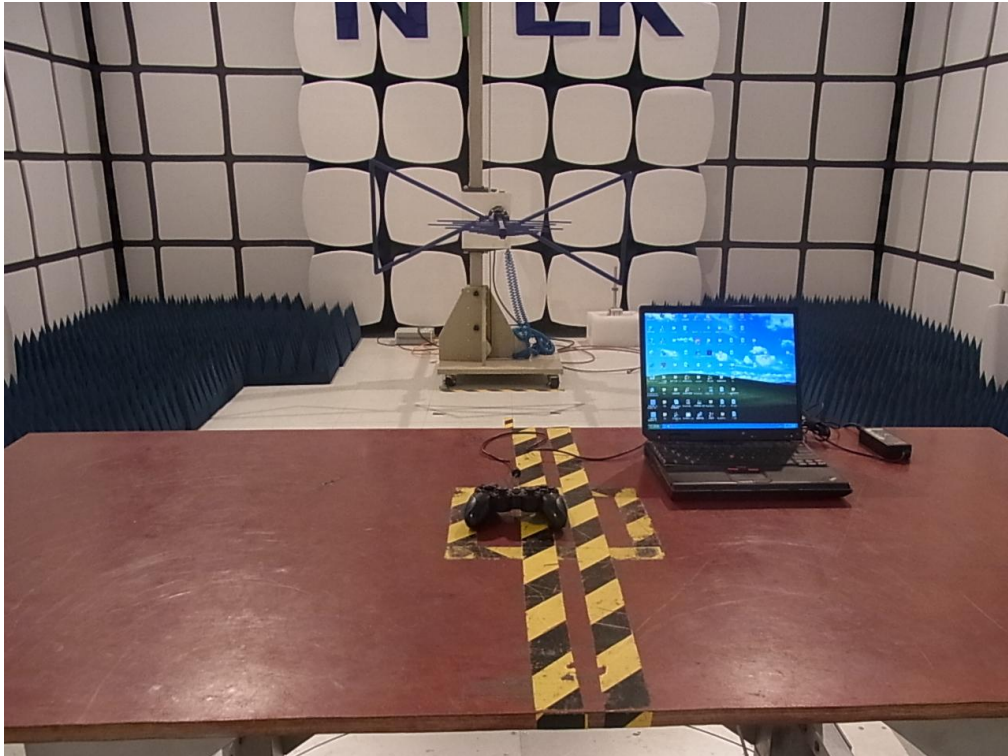

Conducted Measurement Photos

