



MEASUREMENT REPORT

FCC PART 15.239

FCC ID: TW8-1639B

APPLICANT: dreamGEAR, LLC

Application Type: Certification

Product: FM TRANSMITTER

Model No.: ISOUND-1639

FCC Classification: Part 15 Low Power Communication Device Transmitter (DXX)

FCC Rule Part(s): Part 15.239

Test Procedure(s): ANSI C63.10-2009

Test Date: July 15 ~ July 27, 2014

Reviewed By : Robin Wu
(Robin Wu)

Approved By : Marlin Chen
(Marlin Chen)

The test results relate only to the samples tested.

This equipment has been shown to be capable of compliance with the applicable technical standards as indicated in the measurement report and was tested in accordance with the measurement procedures specified in ANSI C63.10-2009. Test results reported herein relate only to the item(s) tested.

The test report shall not be reproduced except in full without the written approval of MRT Technology (Suzhou) Co., Ltd.

Revision History

Report No.	Version	Description	Issue Date
1508RSU00601	Rev. 01	Initial report	08-07-2015

Note: This report was based on MRT report "1407RSU023". There was different of Battery Capacity, and the other was the same.

CONTENTS

Description	Page
1. INTRODUCTION	5
1.1. Scope	5
1.2. MRT Test Location	5
2. PRODUCT INFORMATION	6
2.1. Equipment Description.....	6
2.2. Test Standards	7
2.3. Test Methodology	7
2.4. EUT Setup and Test Mode	7
3. ANTENNA REQUIREMENTS	8
4. TEST EQUIPMENT CALIBRATION DATA	9
5. MEASUREMENT UNCERTAINTY	10
6. TEST RESULT	11
6.1. Summary	11
6.2. Occupied Bandwidth	12
6.2.1. Standard Applicable	12
6.2.2. Test Procedure.....	12
6.2.3. Test Setup.....	12
6.2.4. Test Results	13
6.3. Fundamental Radiated Emission	15
6.3.1. Standard Applicable	15
6.3.2. Test Procedure.....	15
6.3.3. Test Setup.....	15
6.3.4. Test Result.....	16
6.4. Spurious Radiated Emissions and Band-edge	17
6.4.1. Standard Applicable	17
6.4.2. Test Procedure.....	17
6.4.3. Test Setup.....	18
6.4.4. Test Result.....	19
6.5. AC Conducted Emissions Measurement.....	23
6.5.1. Test Limit	23
6.5.2. Test Setup.....	23
6.5.3. Test Result.....	24
7. CONCLUSION	26

§2.1033 General Information

Applicant:	dreamGEAR, LLC
Applicant Address:	20001 S. Western Avenue Torrance, CA 90501.
Manufacturer:	Creative Game Accessories Co., LTD
Manufacturer Address:	2/F, Block A , No.1 Industrial Park, Phoenix No.3 Industrial Zone, Fuyong Street, Bao'an District, Shenzhen, China
Test Site:	MRT Technology (Suzhou) Co., Ltd
Test Site Address:	D8 Building, Youxin Industrial Park, No.2 Tian'edang Rd., Wuzhong Economic Development Zone, Suzhou, China
MRT Registration No.:	809388
FCC Rule Part(s):	Part 15.239
Model No.	ISOUND-1639
FCC ID:	TW8-1639B
Test Device Serial No.:	N/A <input type="checkbox"/> Production <input checked="" type="checkbox"/> Pre-Production <input type="checkbox"/> Engineering
FCC Classification:	Part 15 Low Power Communication Device Transmitter (DXX)
Date(s) of Test:	July 15 ~ July 27, 2014
Test Report S/N:	1508RSU00601

1. INTRODUCTION

1.1. Scope

Measurement and determination of electromagnetic emissions (EMC) of radio frequency devices including intentional and/or unintentional radiators for compliance with the technical rules and regulations of the Federal Communications Commission and the Industry Canada Certification and Engineering Bureau.

1.2. MRT Test Location

The map below shows the location of the MRT LABORATORY, its proximity to the Taihu Lake. These measurement tests were conducted at the MRT Technology (Suzhou) Co., Ltd. Facility located at D8 Building, Youxin Industrial Park, No.2 Tian'edang Rd., Wuzhong Economic Development Zone, Suzhou, China. The detailed description of the measurement facility was found to be in compliance with the requirements of § 2.948 according to ANSI C63.4-2009 on September 30, 2013.



2. PRODUCT INFORMATION

2.1. Equipment Description

Product Name	FM TRANSMITTER
Model No.	ISOUND-1639
Frequency Range	88.1 ~ 107.9 MHz
Type of modulation	FM
Antenna Type	Integral Antenna
Antenna Gain	0dBi
Device Category	Fixed Device

2.2. Test Standards

The following report is prepared on behalf of the dreamGEAR, LLC in accordance with FCC Part 15, Subpart C, and section 15.239, 15.203, 15.205 and 15.209 of the Federal Communication Commissions rules.

The objective is to determine compliance with FCC Part 15, Subpart C, and section 15.239, 15.203, 15.205 and 15.209 of the Federal Communication Commissions rules.

Maintenance of compliance is the responsibility of the manufacturer. Any modification of the product, which results in lowering the emission/immunity, should be checked to ensure compliance has been maintained.

2.3. Test Methodology

The measurement procedures described in the American National Standard for Testing Unlicensed Wireless Devices (ANSI C63.10-2009).

Deviation from measurement procedure.....None

2.4. EUT Setup and Test Mode

The EUT was operated at continuous transmitting mode that was for the purpose of the measurements. All testing shall be performed under maximum output power condition, and to measure its highest possible emissions level, more detailed description as follows:

Test Mode List		
Test Mode	Description	Remark
Mode 1	Transmitting	With modulation

Special Cable List and Details			
Cable Description	Length (m)	Shielded / Unshielded	With / Without Ferrite
USB Cable	0.6	Shielded	N/A

Auxiliary Equipment List and Details			
Description	Manufacturer	Model	Serial Number
Mobile Phone	Apple Inc.	IPhone4	N/A
Adapter	Supply by MRT	HSU50600F	N/A

3. ANTENNA REQUIREMENTS

Excerpt from §15.203 of the FCC Rules/Regulations:

“An intentional radiator antenna shall be designed to ensure that no antenna other than that furnished by the responsible party can be used with the device. The use of a permanently attached antenna or of an antenna that uses a unique coupling to the intentional radiator shall be considered sufficient to comply with the provisions of this section.”

- The antenna of the FM TRANSMITTER is **permanently attached**.
- There are no provisions for connection to an external antenna.

Conclusion:

The **FM TRANSMITTER FCC ID: TW8-1639B** unit complies with the requirement of §15.203.

4. TEST EQUIPMENT CALIBRATION DATA

Radiated Emission

Instrument	Manufacturer	Type No.	Asset No.	Cali. Interval	Cal. Due. Date
EMI Test Receiver	R&S	ESR7	MRTSUE06001	1 year	2014/11/08
TRILOG Antenna	Schwarzbeck	VULB9162	MRTSUE06022	1 year	2014/11/24
Temperature/Humidity Meter	Anymetre	TH101B	MRTSUE06046	1 year	2014/11/15

Conducted Emissions

Instrument	Manufacturer	Type No.	Asset No.	Cali. Interval	Cal. Due Date
EMI Test Receiver	R&S	ESR7	MRTSUE06001	1 year	2014/11/08
Two-Line V-Network	R&S	ENV216	MRTSUE06002	1 year	2014/11/08
Two-Line V-Network	R&S	ENV216	MRTSUE06003	1 year	2014/11/08
Temperature/ Meter Humidity	Anymetre	TH101B	MRTSUE06047	1 year	2014/11/15

5. MEASUREMENT UNCERTAINTY

Where relevant, the following test uncertainty levels have been estimated for tests performed on the EUT as specified in CISPR 16-4-2. This uncertainty represents an expanded uncertainty expressed at approximately the 95% confidence level using a coverage factor of $k = 2$.

AC Conducted Emission Measurement
Measuring Uncertainty for a Level of Confidence of 95% ($U=2Uc(y)$): 150kHz~30MHz: $\pm 3.46\text{dB}$
Radiated Emission Measurement
Measuring Uncertainty for a Level of Confidence of 95% ($U=2Uc(y)$): 9kHz ~ 1GHz: $\pm 4.18\text{dB}$

6. TEST RESULT

6.1. Summary

Company Name: dreamGEAR, LLC

FCC ID: TW8-1639B

FCC Part Section(s)	Test Description	Test Condition	Test Result
15.239(a)	Occupied Bandwidth	Radiated	Pass
15.239(b)	Fundamental Radiated Emissions		Pass
15.239(c) 15.209, 15.205	Spurious Radiated Emissions and Band-edge		Pass
15.207	Conducted Emissions	Line Conducted	Pass

Notes:

- 1) All modes of operation and data rates were investigated. For radiated emission test, every axis (X, Y, Z) was also verified. The test results shown in the following sections represent the worst case emissions.
- 2) The analyzer plots shown in this section were all taken with a correction table loaded into the analyzer. The correction table was used to account for the losses of the cables and attenuators used as part of the system to connect the EUT to the analyzer at all frequencies of interest.
- 3) All antenna port conducted emissions testing was performed on a test bench with the antenna port of the EUT connected to the spectrum analyzer through calibrated cables and attenuators.

6.2. Occupied Bandwidth

6.2.1. Standard Applicable

Emissions from the intentional radiator shall be confined within a band 200 kHz wide centered on the operating frequency. The 200 kHz band shall lie wholly within the frequency range of 88–108MHz.

6.2.2. Test Procedure

1. Analyzer was set to the center frequency under investigation
2. Set RBW = 3 kHz
3. VBW $\geq 3 \times$ RBW
4. Detector = Peak
5. Trace mode = max hold
6. Sweep = auto couple
7. Allow the trace was allowed to stabilize

6.2.3. Test Setup

30MHz ~ 1GHz Test Setup:

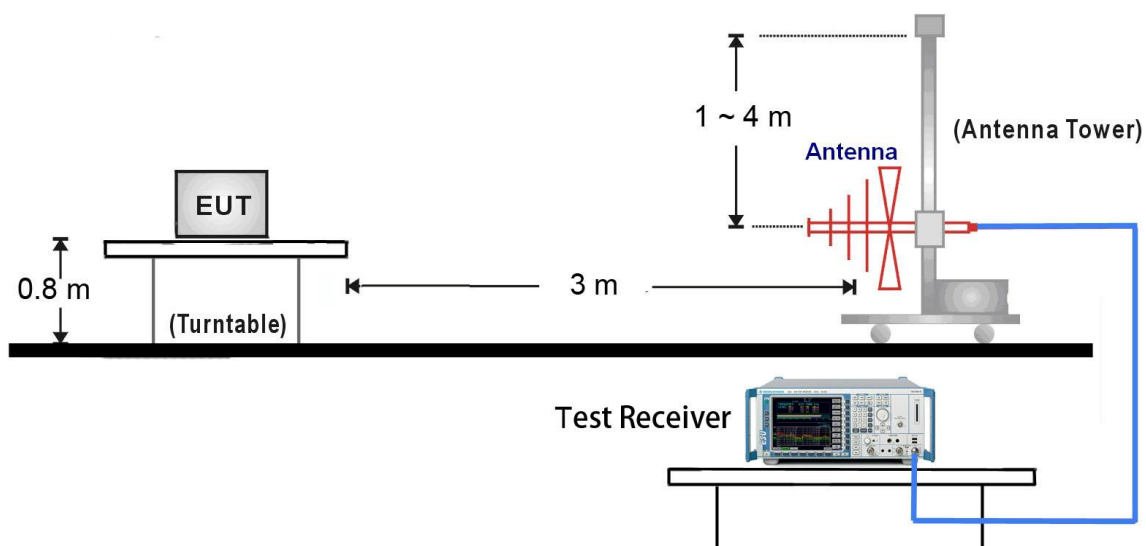

6.2.4. Test Results

Test Frequency (MHz)	20dB Bandwidth (kHz)	Limit (kHz)	Result
88.1	44.67	200	Pass
98.1	44.51	200	Pass
107.9	44.09	200	Pass

Occupied Bandwidth – 88.1MHz

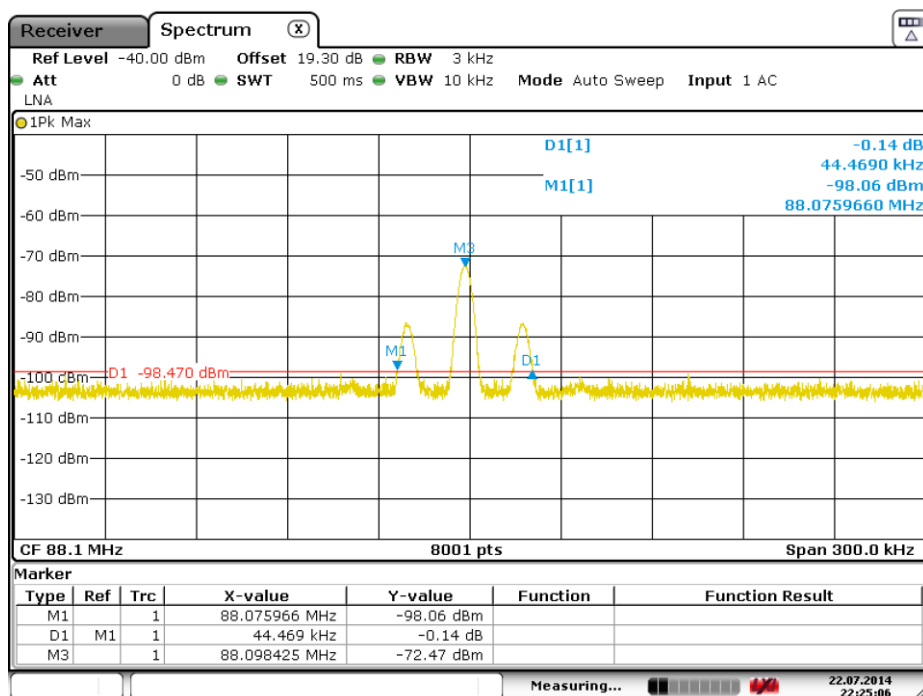

Date: 22.JUL.2014 22:25:05

Occupied Bandwidth – 98.1MHz

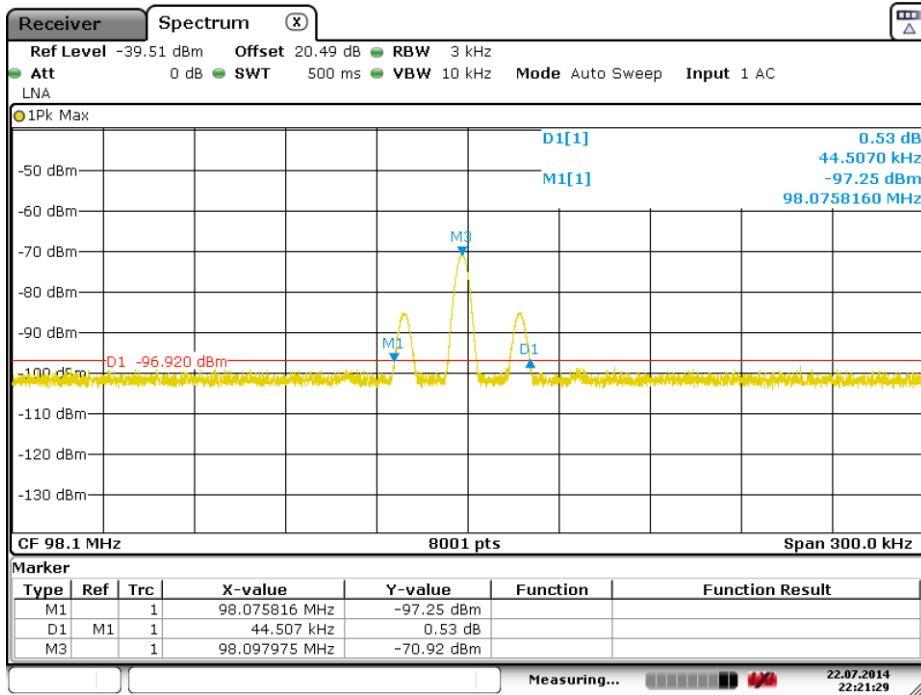

Date: 22.JUL.2014 22:21:28

Occupied Bandwidth – 107.9MHz

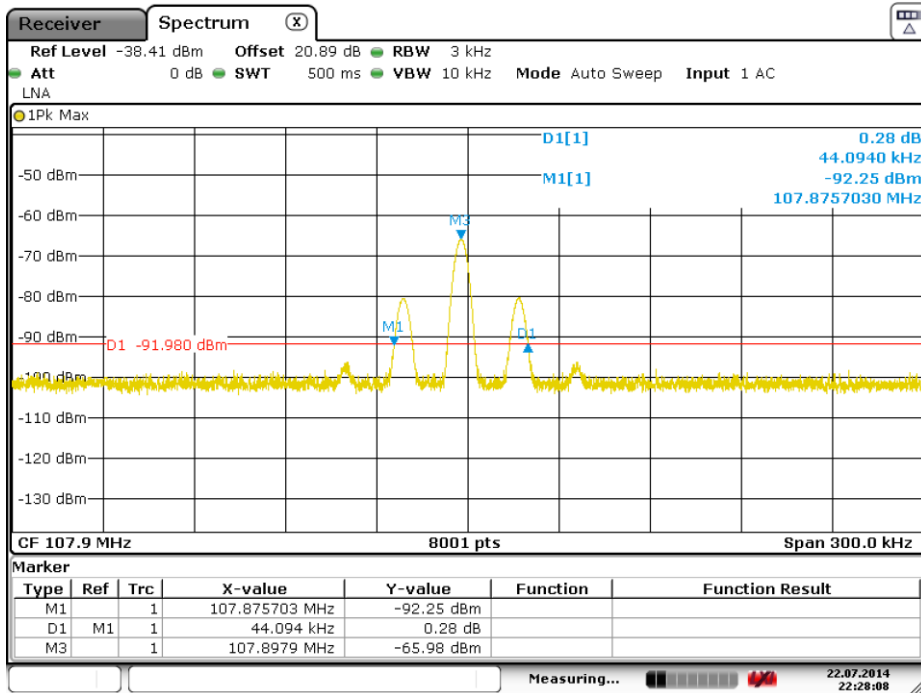

Date: 22.JUL.2014 22:28:08

6.3. Fundamental Radiated Emission

6.3.1. Standard Applicable

The field strength of any emissions within the permitted 200 kHz band shall not exceed 250 microvolts/meter at 3 meters. The emission limit in this paragraph is based on measurement instrumentation employing an average detector. The provisions in §15.35 for limiting peak emissions apply.

Frequency of Emission (MHz)	Field Strength of fundamental (dBuV/m)	
	Peak	Average
88 - 108	68	48

6.3.2. Test Procedure

The setup of EUT is according with per ANSI C63.10-2009 measurement procedure. The specification used was with the FCC Part 15.239(b).

6.3.3. Test Setup

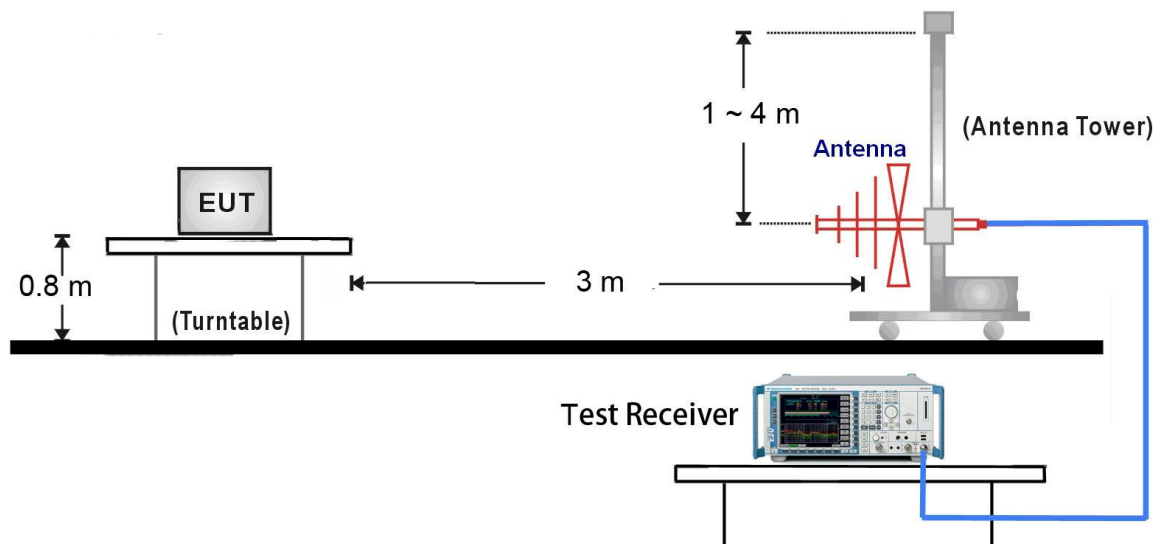

6.3.4. Test Result

Fundamental Radiated Emission(Y Axis)

Test Frequency (MHz)	Reading Level (dB μ V)	Factor (dB)	Measured Level (dB μ V/m)	Limit (dB μ V/m)	Margin (dB)	Result	Detector	Polarization
88.1	14.7	10.5	25.2	68	-42.8	Pass	Peak	Horizontal
	14.6	10.5	25.1	48	-22.9	Pass	Average	Horizontal
	36.1	10.5	46.6	68	-21.4	Pass	Peak	Vertical
	36.0	10.5	46.5	48	-1.5	Pass	Average	Vertical
98.1	17.8	12.5	30.3	68	-37.7	Pass	Peak	Horizontal
	17.2	12.5	29.7	48	-18.3	Pass	Average	Horizontal
	34.4	12.5	46.9	68	-21.1	Pass	Peak	Vertical
	33.8	12.5	46.3	48	-1.7	Pass	Average	Vertical
107.9	20.6	12.8	33.4	68	-34.6	Pass	Peak	Horizontal
	18.3	12.8	31.1	48	-16.9	Pass	Average	Horizontal
	34.8	12.8	47.6	68	-20.4	Pass	Peak	Vertical
	34.0	12.8	46.8	48	-1.2	Pass	Average	Vertical

Note: Measure Level (dB μ V/m) = Reading Level (dB μ V) + Factor (dB)

Factor (dB) = Cable Loss (dB) + Antenna Factor (dB/m)

6.4. Spurious Radiated Emissions and Band-edge

6.4.1. Standard Applicable

According to FCC 15.239(c), the field strength of any emissions radiated on any frequency outside of the specified 200 kHz band shall not exceed the general radiated emission limits in §15.209.

All out of band emissions appearing in a restricted band as specified in Section 15.205 of the Title 47 CFR must not exceed the limits shown in Table per Section 15.209.

FCC Part 15 Subpart C Paragraph 15.209		
Frequency [MHz]	Field Strength [V/m]	Measured Distance [Meters]
0.009 – 0.490	2400/F (kHz)	300
0.490 – 1.705	24000/F (kHz)	30
1.705 - 30	30	30
30 - 88	100	3
88 - 216	150	3
216 - 960	200	3
Above 960	500	3

6.4.2. Test Procedure

The setup of EUT is according with per ANSI C63.10-2009 measurement procedure. The specification used was with the FCC Part 15.239(c) and FCC Part 15.209 Limit.

6.4.3. Test Setup

9kHz ~ 30MHz Test Setup:

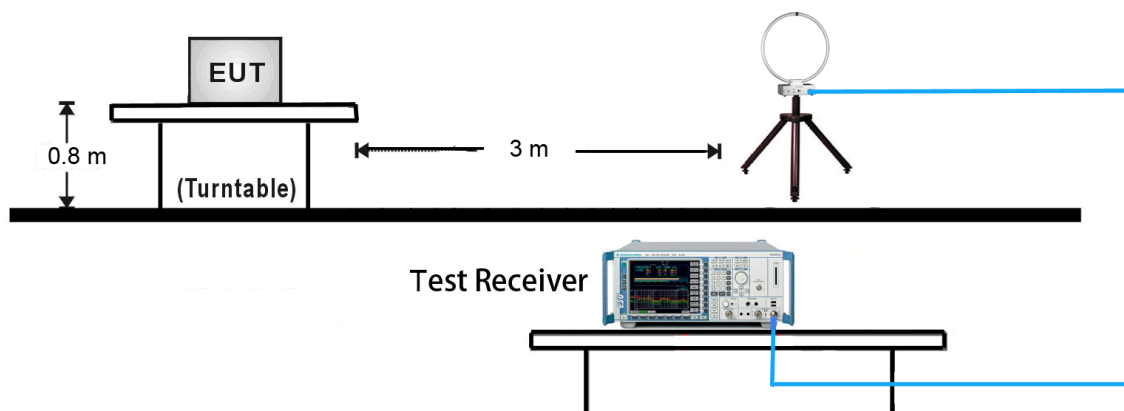

30MHz ~ 1GHz Test Setup:

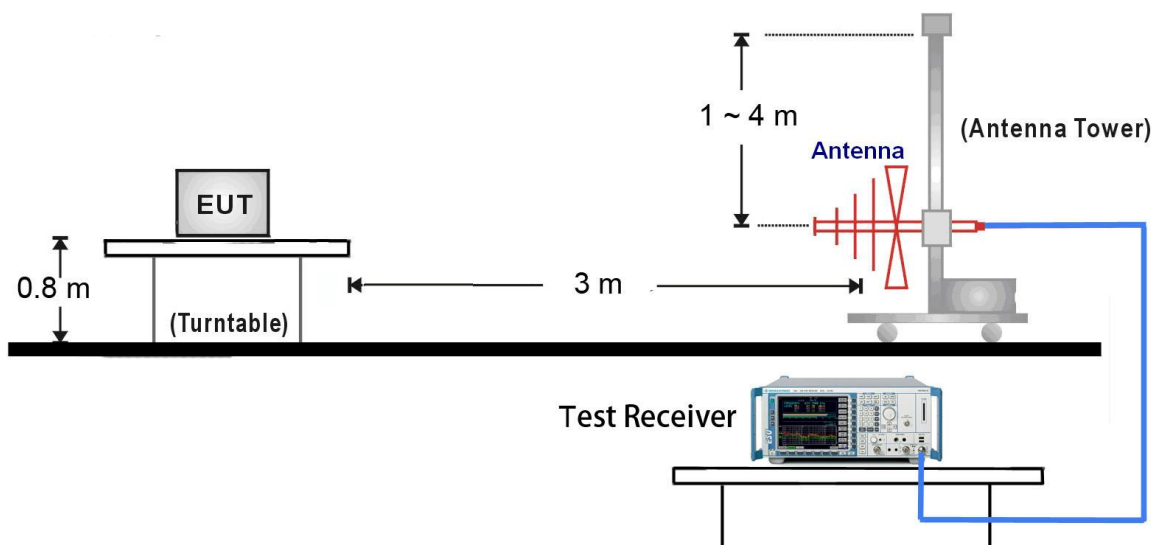

6.4.4. Test Result

Spurious Radiated Emission(Y Axis)

Frequency (MHz)	Reading Level (dBuV)	Factor (dB)	Measured Level (dBuV/m)	Limit (dBuV/m)	Margin (dB)	Result	Detector	Polarization
TX 88.1MHz								
176.1	24.6	10.3	34.9	43.5	-8.6	Pass	QP	Horizontal
264.3	10.7	13.6	24.3	46.0	-21.7	Pass	QP	Horizontal
769.8	-2.0	21.8	19.8	46.0	-26.2	Pass	QP	Horizontal
176.2	28.3	10.3	38.6	43.5	-4.9	Pass	QP	Vertical
528.6	18.8	18.1	36.9	46.0	-9.1	Pass	QP	Vertical
985.9	-2.4	24.0	21.6	46.0	-24.4	Pass	QP	Vertical
TX 98.1MHz								
196.2	12.1	11.8	23.9	43.5	-19.6	Pass	QP	Horizontal
639.8	-1.4	19.9	18.5	46.0	-27.5	Pass	QP	Horizontal
919.5	-1.9	23.5	21.6	46.0	-24.4	Pass	QP	Horizontal
196.2	25.2	11.8	37.0	43.5	-6.5	Pass	QP	Vertical
588.6	6.6	19.3	25.9	46.0	-20.1	Pass	QP	Vertical
965.3	-0.1	23.8	23.7	46.0	-22.3	Pass	QP	Vertical
TX 107.9MHz								
215.8	7.7	12.2	19.9	43.5	-23.6	Pass	QP	Horizontal
323.6	1.3	14.7	16.0	46.0	-30.0	Pass	QP	Vertical
952.5	-1.6	23.7	22.1	46.0	-23.9	Pass	QP	Horizontal
143.9	15.0	9.2	24.2	43.5	-19.3	Pass	QP	Vertical
323.7	2.6	14.7	17.3	46.0	-28.7	Pass	QP	Horizontal
813.7	-2.1	22.3	20.2	46.0	-25.8	Pass	QP	Vertical

Note 1: Testing is carried out with frequency rang 9 kHz to the tenth harmonics. Emissions attenuated more than 20dB below the limit are not reported.

Note 2: Measure Level (dBuV/m) = Reading Level (dBuV) + Factor (dB)

Factor (dB) = Cable Loss (dB) + Antenna Factor (dB/m)

Radiated Band-Edge(Y Axis)

Frequency (MHz)	Reading Level (dBuV)	Factor (dB)	Measured Level (dBuV/m)	Limit (dBuV/m)	Margin (dB)	Result	Detector	Polarization
TX 88.1MHz								
75.2	-0.7	9.5	8.8	40.0	-31.2	Pass	QP	Horizontal
76.1	2.4	9.3	11.7	40.0	-28.3	Pass	QP	Horizontal
75.2	-0.6	9.5	8.9	40.0	-31.1	Pass	QP	Vertical
76.1	20.2	9.3	29.5	40.0	-10.5	Pass	QP	Vertical
TX 107.9MHz								
108.0	16.2	12.8	29.0	43.5	-14.5	Pass	QP	Horizontal
119.9	2.3	11.0	13.3	43.5	-30.2	Pass	QP	Horizontal
108.0	26.1	12.8	38.9	43.5	-4.6	Pass	QP	Vertical
119.9	15.8	11.0	26.8	43.5	-16.7	Pass	QP	Vertical

Note: Measure Level (dBμV/m) = Reading Level (dBμV) + Factor (dB)

Factor (dB) = Cable Loss (dB) + Antenna Factor (dB/m)

Engineer: Milo Li	
Site: AC1	Time: 2014/07/27 - 09:49
Limit: FCC_Part15.209_RE(3m)	Margin: 0
Probe: VULB9162_0.03-8GHz	Polarity: Horizontal
EUT: FM TRANSMITTER	Power: By Battery
Note: Transmit at Channel 88.1MHz Y Axis	

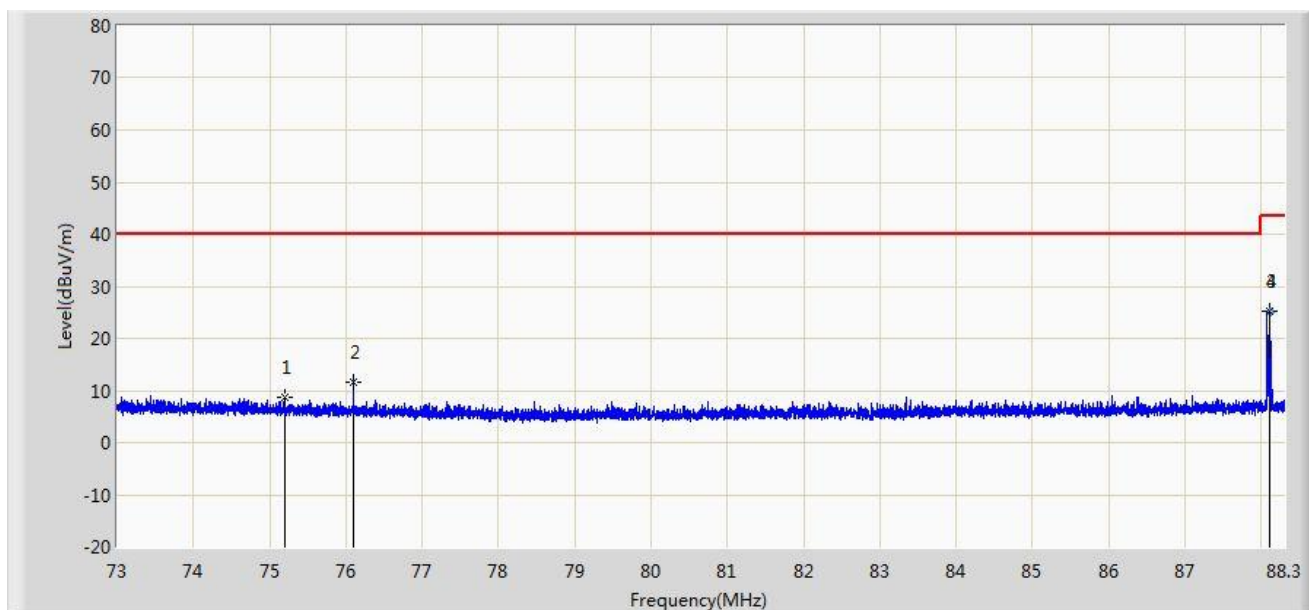

No	Flag	Mark	Frequency (MHz)	Measure Level (dBuV/m)	Reading Level (dBuV)	Over Limit (dB)	Limit (dBuV/m)	Factor	Type
1			75.200	8.778	-0.700	-31.222	40.000	9.478	QP
2			76.100	11.664	2.400	-28.336	40.000	9.264	QP
3		*	88.100	25.232	14.700	N/A	N/A	10.532	PK
4			88.100	25.132	14.600	N/A	N/A	10.532	AV

Note: Measure Level (dBuV/m) = Reading Level (dBuV) + Factor (dB)

Factor (dB) = Cable Loss (dB) + Antenna Factor (dB/m).

Engineer: Milo Li	
Site: AC1	Time: 2014/07/27 - 10:11
Limit: FCC_Part15.209_RE(3m)	Margin: 0
Probe: VULB9162_0.03-8GHz	Polarity: Vertical
EUT: FM TRANSMITTER	Power: By Battery
Note: Transmit at Channel 88.1MHz Y Axis	

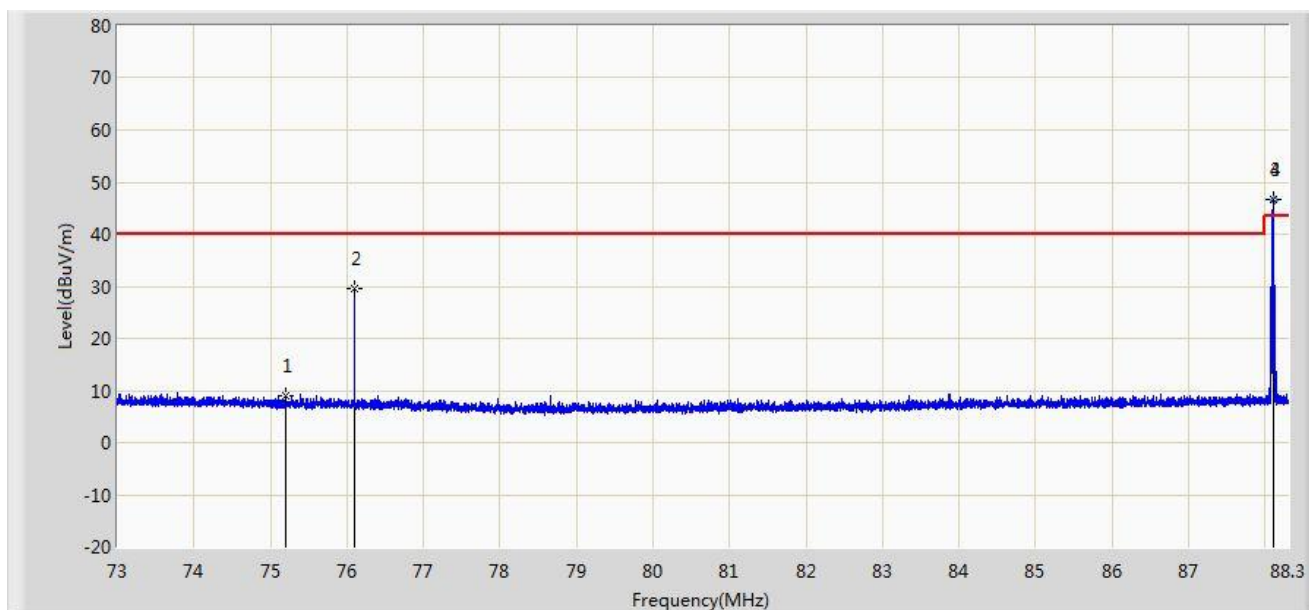

No	Flag	Mark	Frequency (MHz)	Measure Level (dBuV/m)	Reading Level (dBuV)	Over Limit (dB)	Limit (dBuV/m)	Factor	Type
1			75.200	8.878	-0.600	-31.122	40.000	9.478	QP
2			76.100	29.464	20.200	-10.536	40.000	9.264	QP
3		*	88.100	46.632	36.100	N/A	N/A	10.532	PK
4			88.100	46.532	36.000	N/A	N/A	10.532	AV

Note: Measure Level (dBuV/m) = Reading Level (dBuV) + Factor (dB)

Factor (dB) = Cable Loss (dB) + Antenna Factor (dB/m).

6.5. AC Conducted Emissions Measurement

6.5.1. Test Limit

FCC Part 15 Subpart C Paragraph 15.207 Limits		
Frequency (MHz)	QP (dBuV)	AV (dBuV)
0.15 - 0.50	66 - 56	56 - 46
0.50 - 5.0	56	46
5.0 - 30	60	50

Note 1: The lower limit shall apply at the transition frequencies.

Note 2: The limit decreases linearly with the logarithm of the frequency in the range 0.15MHz to 0.5MHz.

6.5.2. Test Setup

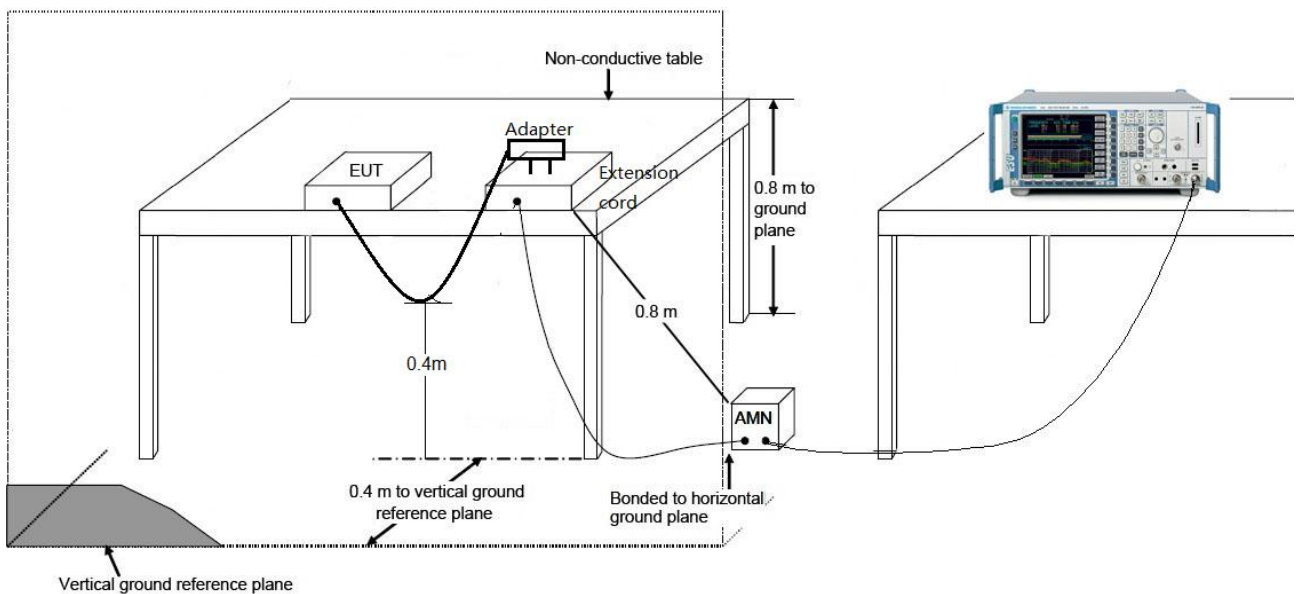

6.5.3. Test Result

Engineer: Milo Li	
Site: SR2	Time: 2014/07/26 - 18:40
Limit: FCC_Part15.207_CE_AC Power	Margin: 0
Probe: ENV216_101683_Filter On	Polarity: Line
EUT: FM TRANSMITTER	Power: AC 120V/60Hz
Note: Mode 1	

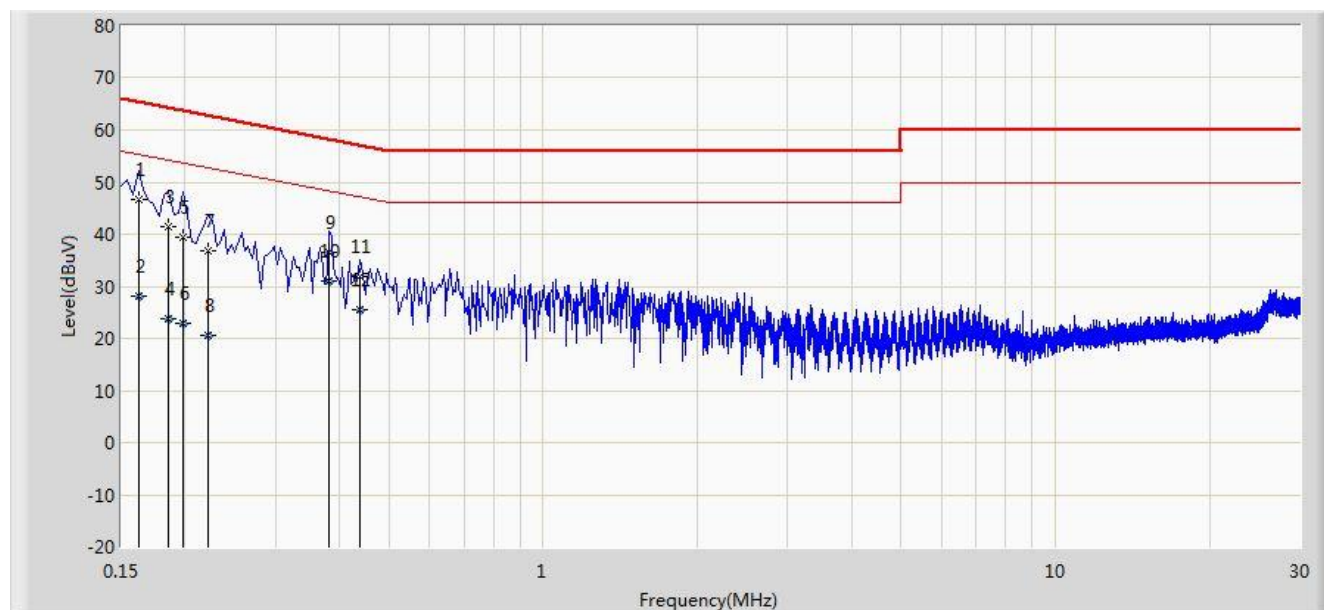

No	Flag	Mark	Frequency (MHz)	Measure Level (dBuV)	Reading Level (dBuV)	Over Limit (dB)	Limit (dBuV)	Factor (dB)	Type
1			0.162	46.569	36.472	-18.791	65.361	10.097	QP
2			0.162	28.166	18.069	-27.194	55.361	10.097	AV
3			0.186	41.502	31.464	-22.711	64.213	10.039	QP
4			0.186	23.884	13.846	-30.329	54.213	10.039	AV
5			0.198	39.386	29.381	-24.308	63.694	10.005	QP
6			0.198	22.820	12.815	-30.874	53.694	10.005	AV
7			0.222	36.910	26.969	-25.834	62.744	9.941	QP
8			0.222	20.557	10.616	-32.187	52.744	9.941	AV
9			0.382	36.644	26.574	-21.592	58.236	10.071	QP
10		*	0.382	30.892	20.821	-17.344	48.236	10.071	AV
11			0.438	31.770	21.654	-25.329	57.100	10.117	QP
12			0.438	25.570	15.454	-21.529	47.100	10.117	AV

Note: Measure Level (dBμV) = Reading Level (dBμV) + Factor (dB)

Factor (dB) = Cable Loss (dB) + LISN Factor (dB)

Engineer: Milo Li	
Site: SR2	Time: 2014/07/26 - 18:45
Limit: FCC_Part15.207_CE_AC Power	Margin: 0
Probe: ENV216_101683_Filter On	Polarity: Neutral
EUT: FM TRANSMITTER	Power: AC 120V/60Hz
Note: Mode 1	

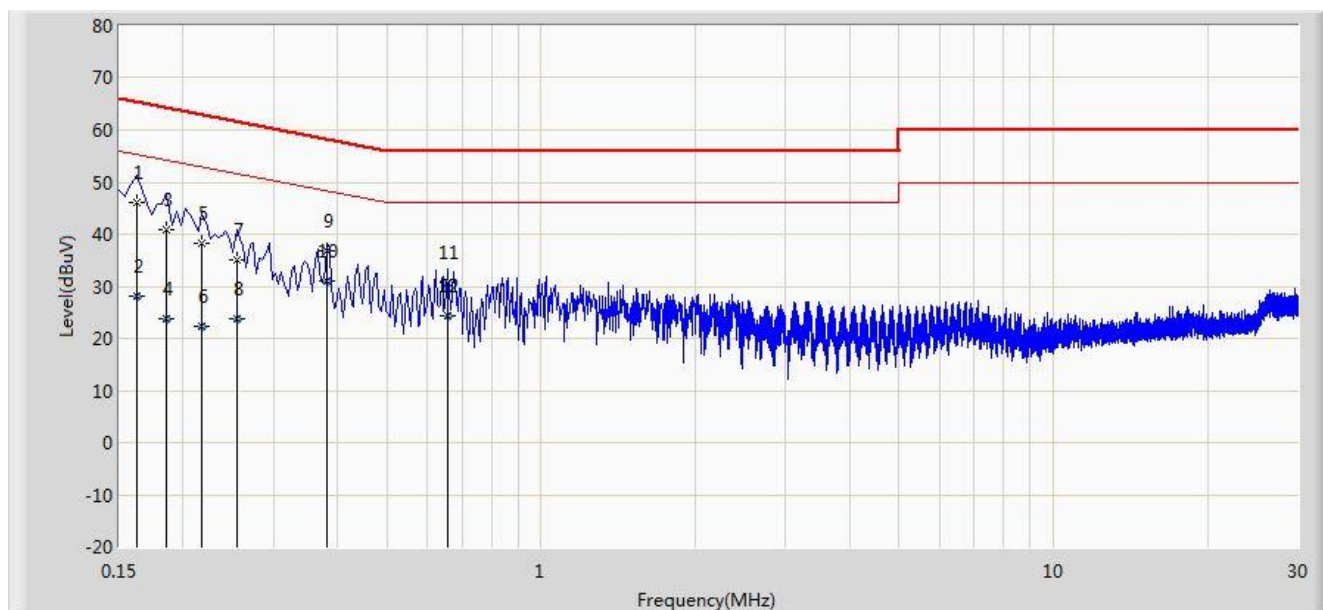

No	Flag	Mark	Frequency (MHz)	Measure Level (dBuV)	Reading Level (dBuV)	Over Limit (dB)	Limit (dBuV)	Factor (dB)	Type
1			0.162	46.117	36.039	-19.244	65.361	10.078	QP
2			0.162	27.999	17.921	-27.361	55.361	10.078	AV
3			0.186	40.919	30.884	-23.294	64.213	10.035	QP
4			0.186	23.783	13.748	-30.431	54.213	10.035	AV
5			0.218	38.252	28.271	-24.643	62.895	9.981	QP
6			0.218	22.308	12.327	-30.586	52.895	9.981	AV
7			0.254	34.984	24.980	-26.641	61.625	10.004	QP
8			0.254	23.902	13.898	-27.723	51.625	10.004	AV
9			0.382	36.859	26.760	-21.377	58.236	10.099	QP
10		*	0.382	31.065	20.966	-17.171	48.236	10.099	AV
11			0.658	30.721	20.623	-25.279	56.000	10.099	QP
12			0.658	24.317	14.218	-21.683	46.000	10.099	AV

Note: Measure Level (dBμV) = Reading Level (dBμV) + Factor (dB)

Factor (dB) = Cable Loss (dB) + LISN Factor (dB)

7. CONCLUSION

The data collected relate only the item(s) tested and show that the **FM TRANSMITTER FCC ID: TW8-1639B** is in compliance with FCC Part 15.239 of the FCC Rules.

_____ The End _____