

Recognized by the  
Federal Communications Commission  
**Anechoic chamber registration no.: 90462 (FCC)**  
**Anechoic chamber registration no.: 3463 (IC)**  
TCB ID: DE 0001



Accredited by the  
German Accreditation Council  
DAR-Registration Number  
DAT-P-176/94-D1



Independent ETSI  
compliance test house



## Accredited Bluetooth® Test Facility (BQTF)

<b>Test report no.</b>	:	<b>2-4189-01-04/05</b>
<b>Applicant</b>	:	<b>Siemens Home and Office Communication</b>
<b>Type</b>	:	<b>Gigaset S45 / E45</b>
<b>Test Standard</b>	:	<b>FCC Part 15.319 RSS-213 Issue 2</b>
<b>FCC ID</b>	:	<b>TVU-S45-E45</b>
<b>Certification No. IC</b>	:	<b>267U-S45E45</b>

## Table of contents

<b>1. ADMINISTRATIVE DATA .....</b>	<b>5</b>
1.1. ADMINISTRATIVE DATA OF THE TEST FACILITY .....	5
1.1.1 Identification of the testing laboratory .....	5
1.1.2 Organizational items.....	5
1.1.3 Applicant's details .....	6
1.2 ADMINISTRATIVE DATA OF MANUFACTURER / MEMBER .....	6
1.3 DESCRIPTION OF THE EQUIPMENT UNDER TEST (EUT) .....	7
1.3.1 EUT: Type, S/N etc. ....	7
1.3.2 Technical specifications.....	7
1.3.3 Additional EUT information For IC Canada (appendix 2).....	8
1.3.4 EUT operating modes .....	<i>Fehler! Textmarke nicht definiert.</i>
1.3.5 Extreme conditions testing values.....	<i>Fehler! Textmarke nicht definiert.</i>
<b>2. TESTSTANDARD &amp; SUMMARY LIST OF ALL PERFORMED TEST CASES .....</b>	<b>9</b>
2.1 TEST AND EVALUATION RESULTS .....	9
2.2 ADDITIONAL INFORMATION ABOUT THE SAMPLE.....	11
<b>3. DESCRIPTION OF TEST SET-UP .....</b>	<b>12</b>
3.1 RADIATED MEASUREMENTS.....	12
3.2 CONDUCTED MEASUREMENTS .....	13
<b>4 DETAILED TEST PROCEDURES AND RESULTS .....</b>	<b>14</b>
4.1 EMISSION BANDWIDTH.....	14
4.1.1 Test Criteria.....	14
4.1.2 Test Procedure.....	15
4.1.3 Test Results .....	15
4.2 CONDUCTED EMISSIONS .....	15
4.2.1 Test Criteria.....	15
4.2.2 Test Procedure.....	15
4.2.3 Test Results .....	15
4.3 ANTENNA REQUIREMENTS .....	15
4.3.1 Test Criteria.....	15
4.3.2 Procedure .....	15
4.3.3 Attestation.....	15
5.4 USE OF DIGITAL MODULATION .....	15
5.4.1 Test Criteria.....	15
5.4.2 Procedure .....	15
5.4.3 Attestation.....	15
4.5 PEAK TRANSMIT POWER .....	15
4.5.1 Test Criteria.....	15
4.5.2 Test Procedure.....	15
4.5.3 Test results.....	15
4.6 POWER SPECTRAL DENSITY .....	15
4.6.1 Test Criteria.....	15
4.6.2 Test procedure .....	15
4.6.3 Test Results .....	15
4.7 POWER ADJUSTMENT FOR ANTENNA GAIN .....	15
4.7.1 Test Criteria.....	15
4.7.2 Test Procedure.....	15
4.7.3 Test Results .....	15
4.8 AUTOMATICALLY DISCONTINUED TRANSMISSION .....	15
4.8.1 Test Criteria.....	15
4.8.2 Test Procedure.....	15
4.8.3 Test Result.....	15

4.9	SPURIOUS EMISSIONS & OUT OF BAND EMISSIONS .....	15
4.9.1	Test Criteria.....	15
4.9.1.1	Out of Band Emissions.....	15
4.9.1.2	Spurious and In-Band Unwanted Emissions.....	15
4.9.2	Test Procedure.....	15
4.9.3	Test Results .....	15
4.9.3.1	Out of Band Emissions.....	15
4.9.3.2	Spurious and In-Band Unwanted Emissions.....	15
4.10	LISTEN BEFORE TALK .....	15
4.10.1	Test Criteria.....	15
4.10.2	Test Procedure.....	15
4.10.3	Attestation.....	15
4.11	MONITORING TIME.....	15
4.11.1	Test Criteria.....	15
4.11.2	Test Procedure.....	15
4.11.3	Test results.....	15
4.12	MONITORING THRESHOLD.....	15
4.12.1	Test Criteria.....	15
4.12.2	Test Procedure.....	15
4.12.3	Test Results .....	15
4.13	MAXIMUM TRANSMIT TIME .....	15
4.13.1	Test Criteria.....	15
4.13.2	Test Procedure.....	15
4.13.3	Test Results .....	15
4.14	SYSTEM ACKNOWLEDGEMENT .....	15
4.14.1	Test criteria.....	15
4.14.2	Test procedure.....	15
4.14.3	Test results.....	15
4.15	LEAST INTERFERED CHANNEL.....	15
4.15.1	Test Criteria.....	15
4.15.2	Test procedure.....	15
4.15.3	Test Results .....	15
4.16	CHANNEL CONFIRMATION.....	15
4.16.1	Test Criteria.....	15
4.16.2	Test Procedure.....	15
4.16.3	Test results.....	15
4.17	POWER MEASUREMENT RESOLUTION.....	15
4.17.1	Test Criteria.....	15
4.17.2	Test procedure.....	15
4.17.3	Test Result.....	15
4.18	SEGMENT OCCUPANCY.....	15
4.18.1	Test Criteria.....	15
4.18.2	Test Procedure.....	15
4.18.3	Attestation.....	15
4.19	RANDOM WAITING .....	15
4.19.1	Test Criteria.....	15
4.19.2	Test Procedure.....	15
4.19.3	Attestation.....	15
4.20	MONITORING BANDWIDTH.....	15
4.20.1	Test Criteria.....	15
4.20.2	Test Procedure.....	15
4.21	MONITORING REACTION TIME.....	15
4.21.1	Test Criteria.....	15
4.21.2	Test Procedure.....	15
4.21.3	Test results.....	15

4.22	MONITORING ANTENNA .....	15
4.22.1	Test Criteria.....	15
4.22.2	Test Procedure.....	15
4.22.3	Attestation.....	15
4.23	MONITORING THRESHOLD RELAXATION .....	15
4.23.1	Test Criteria.....	15
4.23.2	Test Procedure.....	15
4.23.3	Test Results .....	15
4.24	DUPLEX SYSTEM LBT .....	15
4.24.1	Test Criteria.....	15
4.24.2	Procedure .....	15
4.24.3	Test Results .....	15
4.25	ALTERNATE MONITORING CHANNEL .....	15
4.25.1	Test Criteria.....	15
4.25.2	Test Procedure.....	15
4.25.3	Test Result.....	15
4.26	FAIR ACCESS .....	15
4.26.1	Test Criteria.....	15
4.26.2	Procedure .....	15
4.26.3	Attestation.....	15
4.27	FRAME PERIOD .....	15
4.27.1	Test Criteria.....	15
4.27.2	Test Procedure.....	15
4.27.3	Test Results .....	15
4.28	FREQUENCY STABILITY .....	15
4.28.1	Test Criteria.....	15
4.28.2	Test Procedure.....	15
4.29	RADIATED EMISSIONS.....	15
4.29.1	Test Criteria.....	15
4.29.2	Test Procedure.....	15
4.29.3	Test Results .....	15
4.30	USED TEST EQUIPMENT.....	15
<b>5</b>	<b>PHOTOGRAPHS OF TEST SET-UP .....</b>	<b>15</b>
<b>6</b>	<b>PHOTOGRAPHS OF EUT .....</b>	<b>15</b>

## 1. Administrative data

### 1.1. Administrative data of the test facility

#### 1.1.1 Identification of the testing laboratory

Company name:	Cetecom ICT Services GmbH
Address:	Untertürkheimerstr. 6-10 D-66117 Saarbruecken Germany
Laboratory accreditation:	DAR-Registration No. DAT-P-176/94-D1 Bluetooth Qualification Test Facility (BQTF)
Responsible for testing laboratory:	Dirk Hausknecht Phone: +49 681 598 0 Fax: +49 681 598 9075 email: info@ict.cetecom.de

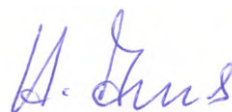

.....  
Responsible for testing  
(Harro Ames)

#### 1.1.2 Organizational items

Reference No.:	2-4189-01-04/05
Order No.:	
Receipt of EUT:	2006-01-26
Date(s) of test:	2006-01-26 to 2006-02-03
Date of report:	2006-02-14
Number of report pages:	108
Number of diagram pages (annex):	
-----	
Version of template:	1.8

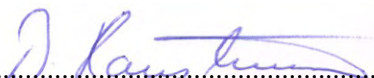

.....  
Responsible for laboratory  
(Dirk Hausknecht)

## Note:

The test results of this test report relate exclusively to the item tested as specified in this report. The CETECOM ICT Services GmbH does not assume responsibility for any conclusions and generalizations drawn from the test results with regard to other specimens or samples of the type of the equipment represented by the test item.

The test report may only be reproduced or published in full. Reproduction or publication of extracts from the report requires the prior written approval of the CETECOM ICT Services GmbH.

During the test no hardware and software changes are allowed to be performed at the EUT.

### 1.1.3 Applicant's details

Name : Siemens Home and Office Communication Devices GmbH & Co KG  
Address : Frankenstr. 2  
City : 46395 Bocholt  
Country : Germany  
Phone : +49-2871-912857  
Fax : +49-2871-9162857  
Contact : Mr. Uwe Alt  
Phone : +49-2871-912857  
Fax : +49-2871-9162857  
e-mail : uwe.alt@siemens.com

### 1.2 Administrative data of manufacturer / member

Manufacturer's name:	Siemens Home and Office Communication Devices GmbH & Co KG
Address:	Frankenstr. 2 46395 Bocholt Germany

## 1.3 Description of the Equipment under test (EUT)

### 1.3.1 EUT: Type, S/N etc.

Product name : Gigaset S45 / E45  
 Description : UPCS Mobile station according to FCC part15.319  
 S/N serial number : -  
 HW hardware status : -  
 SW software status : -  
 Frequency Band [MHz] : 1921.536 – 1928.448 MHz  
 Type of Modulation : TDMA  
 Number of channels : 5  
 Antenna : Monopole antenna  
 Power Supply : 3.0 V DC via external power supply  
 Temperature Range : -20°C - +50°C

Max. power radiated: 18.0 dBm  
 Max. power conducted: 20.0 dBm

FCC ID: TVU-S45-E45  
 IC: 267U-S45E45

### 1.3.2 Technical specifications

The technical specifications of this device are listed below:

Specification	Value
Operating Standard	DECT
Operating Mode	TDMA
Frame Period	10ms
Time Slot Length	416.67µs
Slots per Frame	24 slots / 12 RX, 12 TX
Slot Structure	6 active duplex pairs per frame
Bit Rate	1.152MHz
Bit Period	868.1ns
Number of Frequency Channels	5
Frequency Band	1920 – 1930 MHz
Peak Transmission Power	20.0 dBm maximal conducted 18.0dBm maximal radiated
Emission Bandwidth	2.1 MHz maximal
Gaussian Frequency Shift Keying	B*T = 0.5 nominal
Deviation	400KHz nominal
Speech Codec	32kBit/s ADPCM
Receiver Sensitivity	-93dBm for BER of 1.10exp-3

Frequency Channel	Frequency
CH1	1921.536MHz
CH2	1923.264MHz
CH3	1924.992MHz
CH4	1926.720MHz
CH5	1928.448MHz

### 1.3.3 Additional EUT information For IC Canada (appendix 2)

Company Number:	267U
Certification Number:	267U-S45E45
Model Name:	Gigaset S45 / E45
Manufacturer:	Siemens Home and Office Communication Devices GmbH & Co KG Frankenstr. 2 46395 Bocholt Germany
Tested to Radio Standards Specification (RSS) No.:	RSS-213 Issue 2 / December 2005
Open Area Test Site Industry Canada Number:	3463
Frequency Range (or fixed frequency) [MHz]:	1921.536 – 1928.448 MHz
RF: Power [W] (max):	Rad. EIRP: 18.0 dBm, 63 mW Conducted: 20.0 dBm, 100 mW
Antenna Type:	Monopole antenna
Occupied Bandwidth (99% BW) [kHz]:	MHz
Type of Modulation:	GFSK
Emission Designator (TRC-43):	2M10FXD
Transmitter Spurious (worst case) [ $\mu$ V/m in 3m]:	>20 dB below limit
Receiver Spurious (worst case) [ $\mu$ V/m in 3m]:	>20 dB below limit

ATTESTATION: I attest that the testing was performed or supervised by me; that the test measurements were made in accordance with the above-mentioned departmental standard(s), and that the radio equipment identified in this application has been subject to all the applicable test conditions specified in the departmental standards and all of the requirements of the standards have been met.

Signature:



Date: 2006-02-14

Testengineer: Harro Ames



## 2. Teststandard & summary list of all performed test cases

TC identifier	Description	verdict	date	Remark
RF-Testing	FCC Part 15 - CANADA RSS-213 Draft ANSI-C63.17-2005	PASS	2006-02-14	<b>PASS</b>

### 2.1 Test and evaluation results:

General Requirements				
Requirement	FCC Part / IC Part	Test Procedure <small>(Section numbers refer to ANSI C63.17 unless otherwise noted)</small>	Result	Detailed Results
Emission Bandwidth	15.303(c) & 15.323 (a) / RSS-213 Clause 6.3	6.1.3	PASS	4.1
Labeling Requirements	15.311 & 15.19(a)(3) / RSS-213 Clause 5.1		PASS	Separate Attachment
Conducted Emissions	15.315 & 15.207 / RSS-213 Clause 10.0	ANSI C63.4	PASS	4.2
Antenna Requirements	15.317 & 15.203 / RSS-213 Clause 5.5	Declaration	Attestation	4.3
Use digital modulation	15.319 (b) / RSS-213 Clause 5.4	6.1.4	Attestation	4.4
Peak transmit power	15.303(f) & 15.319 (c) / RSS-213 Clause 7.1	6.1.2	PASS	4.5
Power spectral density	15.319 (d) & 15.107 / RSS-213 Clause 7.2	6.1.5	PASS	4.6
Power adjustment for antenna gain	15.319 (e)	4	Attestation	4.7
Automatically discontinue transmission	15.319 (f) / RSS-213 Clause 7.4.a		PASS	4.8
Spurious emissions conducted	15.319 (g) & 15.209 / RSS-213 Clause 7.3	6.1.6	PASS	4.9
SAR Testing of Handset	15.319 (i) & 1.1307(b), 2.1091 and 2.1093	ANSI/IEEE C95.1	Attestation	See separate Test report

<b>Isochronous Requirements</b>				
<b>Requirement</b>	<b>FCC Part</b>	<b>Test Procedure (Section numbers refer to ANSI C63.17 unless otherwise noted)</b>	<b>Result</b>	<b>Detailed Results</b>
<b>Listen before talk</b>	<b>15.323 (c)</b>	<b>7</b>	<b>PASS</b>	<b>4.10</b>
<b>Monitoring time</b>	<b>15.323 (c)(1) / RSS-213 Clause 8.4</b>	<b>7.3.4</b>	<b>PASS</b>	<b>4.11</b>
<b>Monitoring threshold</b>	<b>15.323 (c)(2) / RSS-213 Clause 8.4</b>	<b>7.3.1</b>	<b>PASS</b>	<b>4.12</b>
<b>Maximum transmit time</b>	<b>15.323 (c)(3) / RSS-213 Clause 8.4</b>	<b>8.2.2</b>	<b>PASS</b>	<b>4.13</b>
<b>System acknowledgement</b>	<b>15.323 (c)(4) / RSS-213 Clause 8.4(c)(4)</b>	<b>8.1.1 &amp; 8.1.2</b>	<b>PASS</b>	<b>4.14</b>
<b>Least Interfered Channel</b>	<b>15.323 (c)(5.1)</b>	<b>7.3.2 &amp; 7.3.3</b>	<b>PASS</b>	<b>4.15</b>
<b>Channel confirmation</b>	<b>15.323 (c)(5.2)</b>	<b>7.3.3 &amp; 7.3.4</b>	<b>PASS</b>	<b>4.16</b>
<b>Power measurement resolution</b>	<b>15.323 (c)(5.3) / RSS-213 Clause 8.4(c)(5)</b>	<b>7.3.3</b>	<b>PASS</b>	<b>4.17</b>
<b>Segment occupancy</b>	<b>15.323 (c)(5.4)</b>	<b>Declaration</b>	<b>Attestation</b>	<b>4.18</b>
<b>Random waiting</b>	<b>15.323 (c)(6) / RSS-213 Clause 8.4</b>	<b>8.1.3</b>	<b>Attestation</b>	<b>4.19</b>
<b>Monitoring bandwidth</b>	<b>15.323 (c)(7.1) / RSS-213 Clause 8.4(c)(7)</b>	<b>7.4</b>	<b>PASS</b>	<b>4.20</b>
<b>Monitoring reaction time</b>	<b>15.323 (c)(7.2) / RSS-213 Clause 8.4(c)(7)</b>	<b>7.5</b>	<b>Attestation</b>	<b>4.21</b>
<b>Monitoring antenna</b>	<b>15.323 (c)(8) / RSS-213 Clause 8.4(c)(8)</b>	<b>4</b>	<b>PASS</b>	<b>4.22</b>
<b>Monitoring threshold relaxation</b>	<b>15.323 (c)(9) / RSS-213 Clause 8.4(c)(9)</b>	<b>4</b>	<b>PASS</b>	<b>4.23</b>
<b>Duplex system LBT</b>	<b>15.323 (c)(10) / RSS-213 Clause 8.4(c)(10)</b>	<b>8.3</b>	<b>Attestation</b>	<b>4.24</b>
<b>Alternate monitoring interval</b>	<b>15.323 (c)(11) / RSS-213 Clause 8.4(c)(11)</b>	<b>8.4</b>	<b>Attestation</b>	<b>4.25</b>

Requirement	FCC Part	Test Procedure (Section numbers refer to ANSI C63.17 unless otherwise noted)	Result	Detailed Results
Fair access	15.323 (c)(12) / RSS-213 Clause 8.4(c)(12)	Declaration	Attestation	4.26
Frame period	15.323 (e) / RSS-213 Clause 8.4(d)	6.2.2 & 6.2.3	PASS	4.27
Frequency stability	15.323 (f) / RSS-213 Clause 8.4(d)	6.2.1	PASS	4.28
Radiated Out of Band Emissions	15.309 (b) & FCC Part 15 Subpart B, 15.109 and 15.209 / RSS-213 Clause 6.2		PASS	4.29

## 2.2 Additional information about the sample

The tested sample is a mobile station for a Wireless Phone according to FCC part15, subpart D (UPCS)

There are two type of stations, S45 and E45. They differ in PCB-layout and material, the RF-part is identical, also the used software.

Therefore we tested the radiated emissions separately for each type, the conducted measurements are the same for both samples.

For testing the sample was equipped with a temporary added coax connector to simplify the measurement.

For some measurements it was necessary to use a connection to a Handset. Hereby we used the dedicated Handset S450 / E450.

The complete test report for the Base station S450 is 2-4189-01-02/05 from our house.

## **3. Description of test set-up**

### **3.1 Radiated measurements**

The radiated measurements are performed in vertical and horizontal plane in the frequency range from 9 kHz to 25 GHz in semi-anechoic chambers. The EUT is positioned on a non-conductive support with a height of 0.80 m above a conductive ground plane that covers the whole chamber. The receiving antennas are conform with specifications ANSI C63.2-1987 clause 15 and ANSI C63.4-2003 clause 4.1.5. These antennas can be moved over the height range between 1.0 m and 4.0 m in order to search for maximum field strength emitted from EUT. The measurement distances between EUT and receiving antennas are indicated in the test setups for the various frequency ranges. For each measurement, the EUT is rotated in all three axes until the maximum field strength is received. The wanted and unwanted emissions are received by spectrum analysers where the detector modes and resolution bandwidths over various frequency ranges are set according to requirement ANSI C63-4-2003 clause 4.2.

Antennas are conform with ANSI C63.2-1996 item 15.

9 kHz - 150 MHz: Quasi Peak measurement, 200 Hz Bandwidth, passive loop antenna.

150 kHz - 30 MHz: Quasi Peak measurement, 9kHz Bandwidth, passive loop antenna.

30 MHz - 200 MHz: Quasi Peak measurement, 120KHz Bandwidth, biconical antenna

200MHz - 1GHz: Quasi Peak measurement, 120KHz Bandwidth, log periodic antenna

1GHz: Average, RBW 1MHz, VBW 10 MHz, waveguide horn

The EUT is powered by a dedicated power supply with nominal voltage.

## 3.2 Conducted measurements

The EUT's RF signal is coupled out by the antenna connector which is supplied by the manufacturer. The signal is first 10dB attenuated before it is power divided (Multicoupler up to 9 branches). One of the signal path is connected to the communication simulator (CMD65 or other), the other one is connected to the spectrum analyzer, others are connected to signal generators an/or handsets . The specific losses for all signal paths are first checked within a calibration. The measuerment readings on the signaling unit/spectrum analyzer are corrected by the specific test set-up loss. All measuring equipment is impedance matched on 50 Ohm.

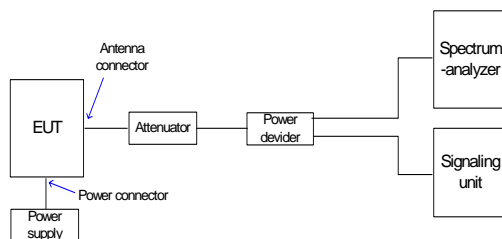

**A dedicated description of test setups can be found at the related tests.**

## **4 Detailed Test Procedures and Results**

### **4.1 Emission Bandwidth**

#### **4.1.1 Test Criteria**

##### **§ 15.303 Definitions.**

**(c) Emission bandwidth.** For purposes of this subpart the emission bandwidth shall be determined by measuring the width of the signal between two points, one below the carrier center frequency and one above the carrier center frequency, that are 26 dB down relative to the maximum level of the modulated carrier. Compliance with the emissions limits is based on the use of measurement instrumentation employing a peak detector function with an instrument resolutions bandwidth approximately equal to 1.0 percent of the emission bandwidth of the device under measurement.

##### **§ 15.323 Specific requirements for isochronous devices operating in the 1920–1930 MHz sub-band.**

**(a) Operation shall be contained within the 1920-1930 MHz band. The emission bandwidth shall be less than 2.5 MHz. The power level shall be as specified in §15.319(c), but in no event shall the emission bandwidth be less than 50 kHz**

## 4.1.2 Test Procedure

Testing to ANSI C63.17 draft ballot 3.0 Clause 6.1.3, which provides the test methodology for this provision.

In order to achieve pseudo random data transfer, as in reality, a connection was setup between the EUT and a Rhode and Schwarz DECT Test Device the CMD 65.

**Test setup:**

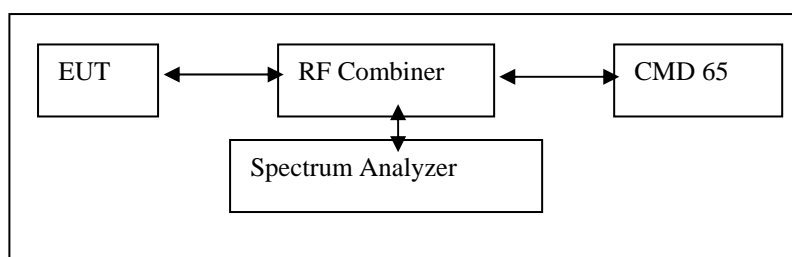

The CMD settings are shown below:

Traffic Carrier Offset	-20
Frequency Channel	4
Traffic Slot	2
RF Level	-70dBm
Data Type	PRBS

The spectrum analyzer is setup according to ANSI C63.17 Clause 6.1.3:

Centre Frequency	CH1, CH3, CH5
RBW	20KHz
VBW	100KHz
Trigger	Free Run
Span	5MHz
Detection	Peak Detection
Sweep Rate	auto
Amplitude Scale	Log
Peak Hold	On

The emission bandwidth of the MS is measured at 23°C and frequency channel CH1, CH3 and CH5.

**Limits:**

According to Part 15.323 (a) the maximum allowable emission bandwidth is 2.5MHz.

## 4.1.3 Test Results

### Emission Bandwidth of MS at Ch1

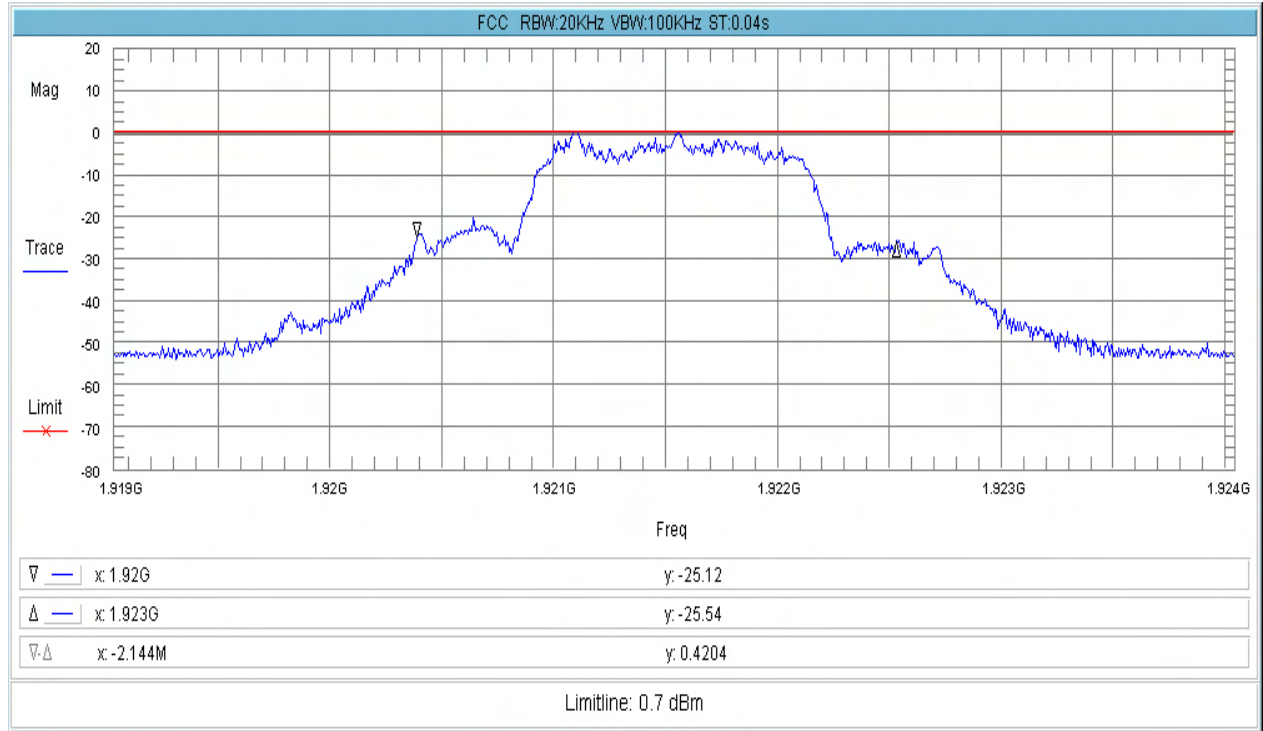

### Emission Bandwidth of MS at Ch3

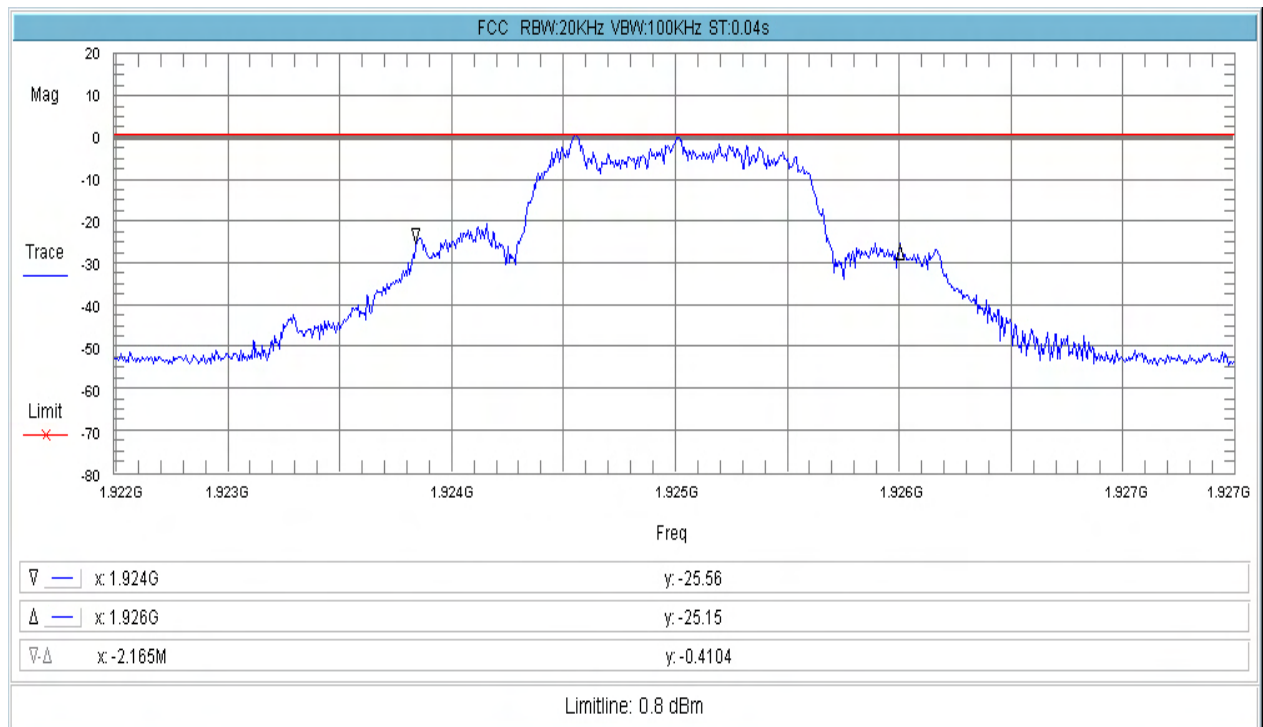



## Emission Bandwidth of MS at Ch5

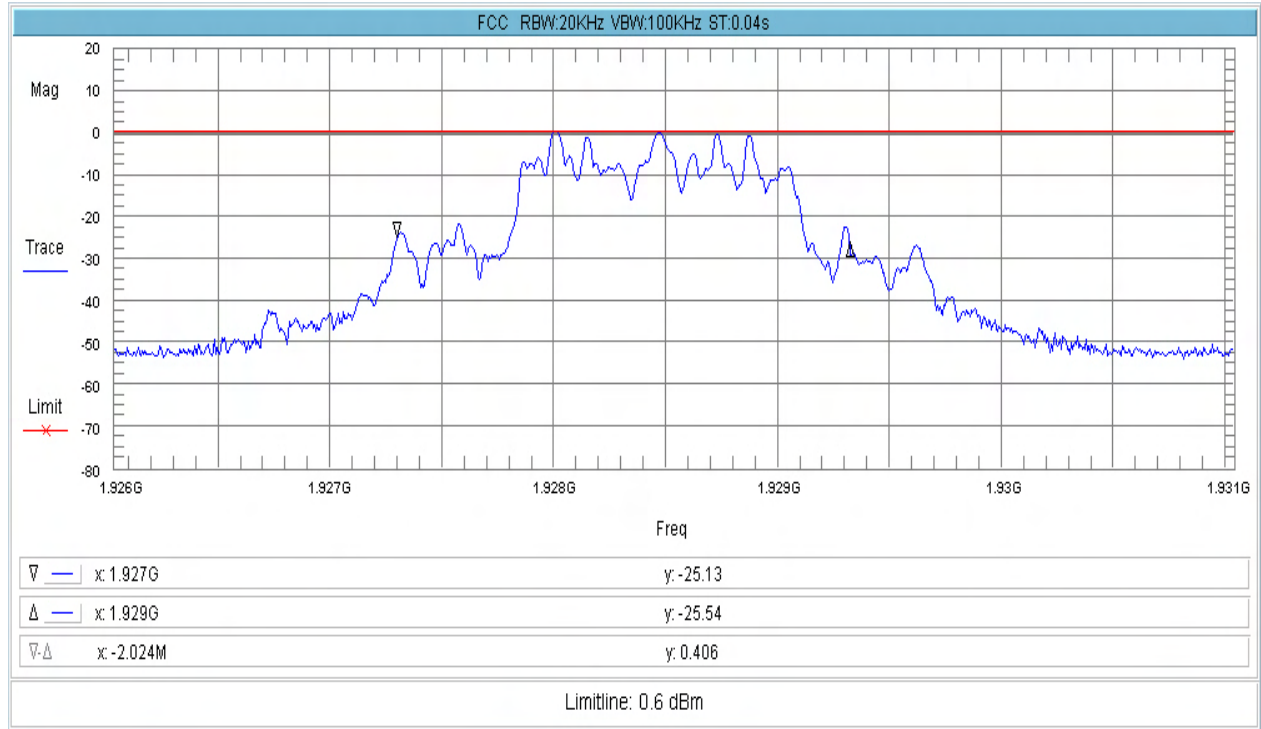

The following results are measured:

Emission Bandwidth	Measurement	Result
CH1	2.14 MHz	Pass
CH2	2.17 MHz	Pass
CH3	2.02 MHz	Pass

**Result: Pass**

## 4.2 Conducted Emissions

### 4.2.1 Test Criteria

#### § 15.315 Conducted limits.

An unlicensed PCS device that is designed to be connected to the public utility (AC) power line must meet the limits specified in § 15.207.

#### § 15.207 Conducted limits.

(a) Except as shown in paragraphs (b) and (c) of this section, for an intentional radiator that is designed to be connected to the public utility (AC) power line, the radio frequency voltage that is conducted back onto the AC power line on any frequency or frequencies, within the band 150 kHz to 30 MHz, shall not exceed the limits in the following table, as measured using a 50  $\mu$ H/50 ohms line impedance stabilization network (LISN). Compliance with the provisions of this paragraph shall be based on the measurement of the radio frequency voltage between each power line and ground at the power terminal. The lower limit applies at the boundary between the frequency ranges.

Frequency of emission (MHz)	Conducted limit (dB $\mu$ V)	Quasi-peak Average
0.15–0.5	66 to 56*	56 to 46*
0.5–5	56	46
5–30	60	50

\*Decreases with the logarithm of the frequency.

(b) The limit shown in paragraph (a) of this section shall not apply to carrier current systems operating as intentional radiators on frequencies below 30MHz. In lieu thereof, these carrier current systems shall be subject to the following standards:

(1) For carrier current system containing their fundamental emission within the frequency band 535–1705 kHz and intended to be received using a standard AM broadcast receiver: no limit on conducted emissions.

(2) For all other carrier current systems: 1000  $\mu$ V within the frequency band 535–1705 kHz, as measured using a 50  $\mu$ H/50 ohms LISN.

(3) Carrier current systems operating below 30 MHz are also subject to the radiated emission limits in § 15.205, § 15.209, § 15.221, § 15.223, or § 15.227, as appropriate.

(c) Measurements to demonstrate compliance with the conducted limits are not required for devices which only employ battery power for operation and which do not operate from the AC power lines or contain provisions for operation while connected to the AC power lines. Devices that include, or make provisions for, the use of battery chargers which permit operating while charging, AC adapters or battery eliminators or that connect to the AC power lines indirectly, obtaining their power through another device which is connected to the AC power lines, shall be tested to demonstrate compliance with the conducted limits.

### 4.2.2 Test Procedure

This test is performed according to ANSI C63.4.

Principle setup for Conducted Emissions at ac power line:

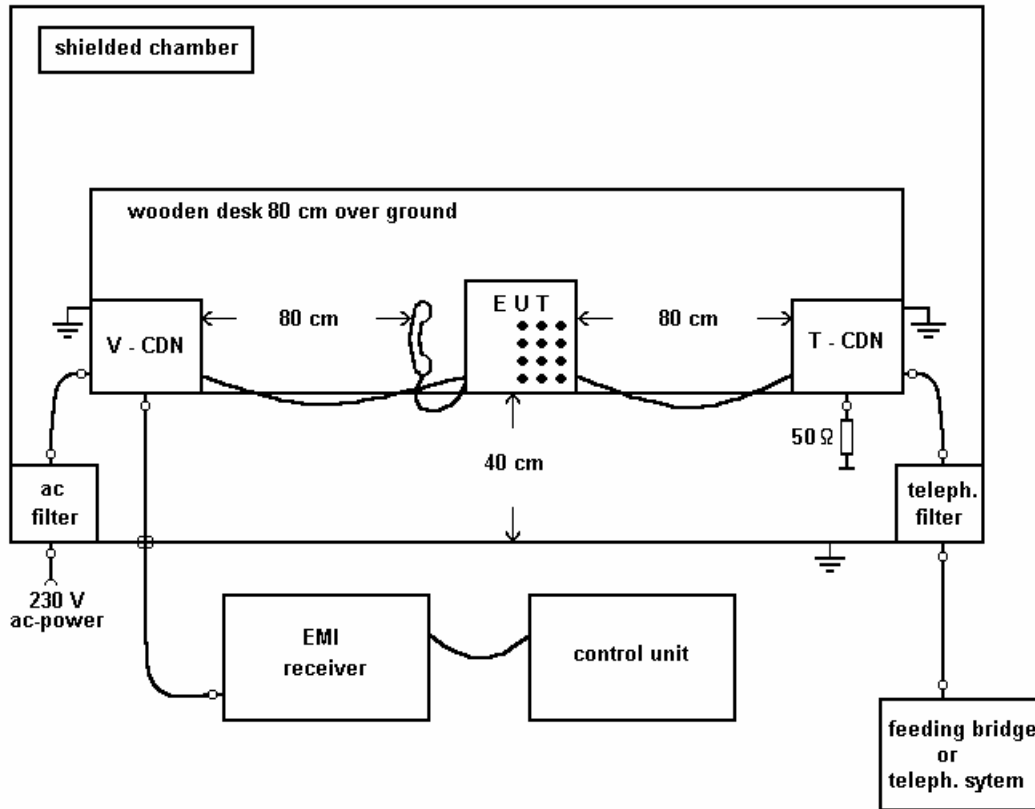

principle set up: conducted emission at ac power line

The following test procedure is applied:

Setup	Test Procedure
1	The EUT was connected to a PBX via CDN-T and filter unit in the charger unit
2	The power supply was connected to a CDN-M2. During measuring at the CDN-M2, the CDN-T was terminated with 50 ohm.
3	A communication link is setup. (Operating Mode)
4	The EUT is set into Standby mode. (Standby Mode)

## 4.2.3 Test Results

Measured in operating and stand-by mode, max hold, same result also for E45

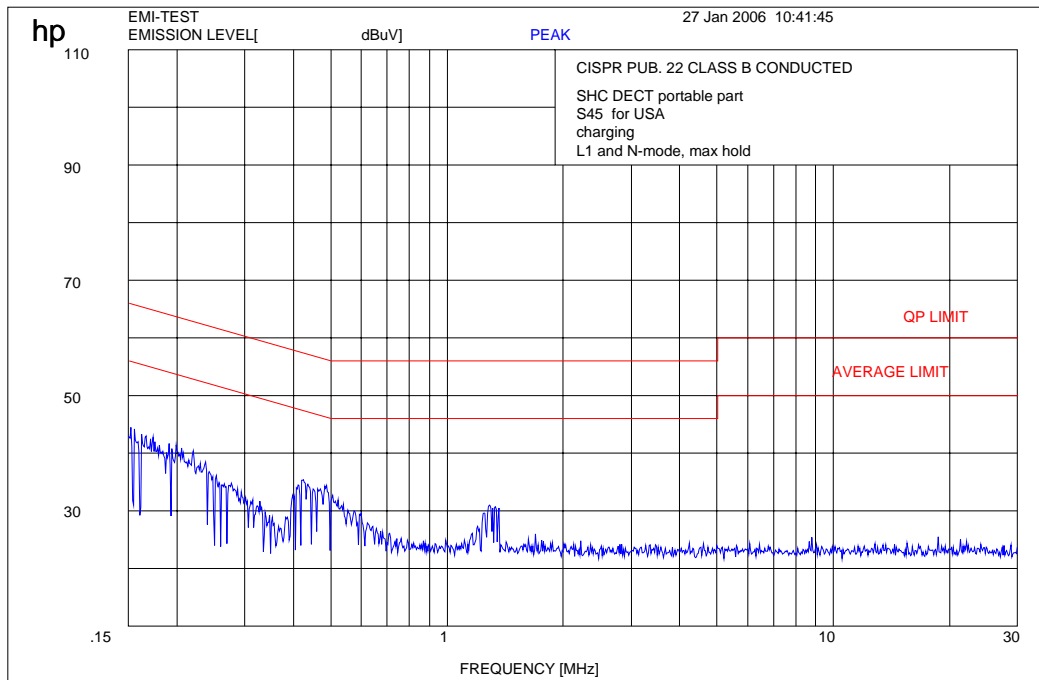

All emissions are below the limits.

**Result: Pass**

## 4.3 Antenna Requirements

### 4.3.1 Test Criteria

#### 47CFR15.203 Antenna requirement.

An intentional radiator shall be designed to ensure that no antenna other than that furnished by the responsible party shall be used with the device. The use of a permanently attached antenna or of an antenna that uses a unique coupling to the intentional radiator shall be considered sufficient to comply with the provisions of this Section. The manufacturer may design the unit so that a broken antenna can be replaced by the user, but the use of a standard antenna jack or electrical connector is prohibited. This requirement does not apply to carrier current devices or to devices operated under the provisions of Sections 15.211, 15.213, 15.217, 15.219, or 15.221. Further, this requirement does not apply to intentional radiators that must be professionally installed, such as perimeter protection systems and some field disturbance sensors, or to other intentional radiators which, in accordance with Section 15.31(d), must be measured at the installation site. However, the installer shall be responsible for ensuring that the proper antenna is employed so that the limits in this Part are not exceeded.

### 4.3.2 Procedure

Attestation of manufacturer supported by photos and/or description of the antenna to allow visual confirmation.

### 4.3.3 Attestation

The MS uses a permanently attached antenna. The antenna is the same for S45 and E45

E45

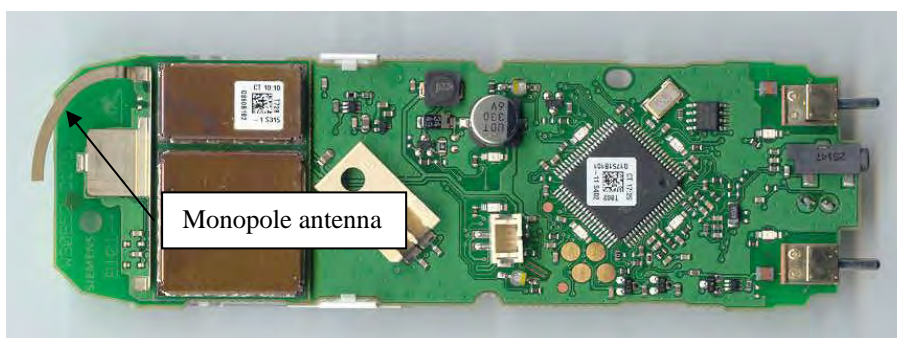

No external antenna can be attached to the device.

## **5.4 Use of Digital Modulation**

### **5.4.1 Test Criteria**

**Section 15.319 General technical requirements.**

**(b) All transmissions must use only digital modulation techniques.**

### **5.4.2 Procedure**

**Attestation of manufacturer supported by reference to relevant DECT specifications.**

### **5.4.3 Attestation**

**This device is compliant with the DECT standards described in European Standards EN 300 175-2 and EN 300 175-3. DECT transmissions are MC/TDMA/TDD (Multi carrier / Time Division Multiple Access / Time Division Duplex) using Digital GFSK modulation.**

**For further details see operational description or relevant portions of the DECT standards.**

## 4.5 Peak Transmit Power

### 4.5.1 Test Criteria

**Section 15.319 General technical requirements.**

**(c) Peak transmit power shall not exceed 100 microwatts multiplied by the square root of the emission bandwidth in hertz. Peak transmit power must be measured over any interval of continuous transmission using instrumentation calibrated in terms of an rms equivalent voltage. The measurement results shall be properly adjusted for any instrument limitations, such as detector response times, limited resolution bandwidth capability when compared to the emission bandwidth, sensitivity, etc., so as to obtain a true peak measurement for the emission in question over the full bandwidth of the channel.**

### 4.5.2 Test Procedure

Testing to ANSI C63.17 draft ballot 3.0 Clause 6.1.2, which provides the test methodology for this provision. The EUT is controlled from a personal computer and set into continuous transmission mode.

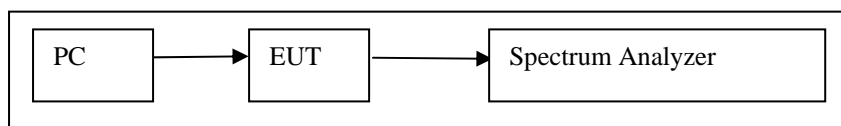

The spectrum analyzer is setup according to ANSI C63.17 Clause 6.1.2:

Centre Frequency	CH1, CH3, CH5
RBW	3MHz
VBW	7MHz
Trigger	Video
Span	zero
Detection	Peak Detection
Sweep Rate	1ms
Amplitude Scale	Log
Peak Hold	On

The peak transmit power of the MS is measured at 23°C and frequency channel CH1, CH3 and CH5.

The maximum peak transmit power is described in ANSI C63.17 Clause 4.3.1.

The antenna gain of the MS antennas is < 3dBi.

Therefore  $P_{\text{limit}} = P_{\text{max}}$

The emission bandwidth = 2.1 MHz and therefore:

$$\begin{aligned}
 P_{\text{max}} &= 5 \log B - 10\text{dBm} \\
 &= 5 \log (2.1 \text{ exp}6) - 10\text{dBm} \\
 &= 21.6 \text{ dBm}
 \end{aligned}$$

The maximum peak transmit power is 21.6 dBm.

## 4.5.3 Test results

Peak Transmit Power of MS at CH1

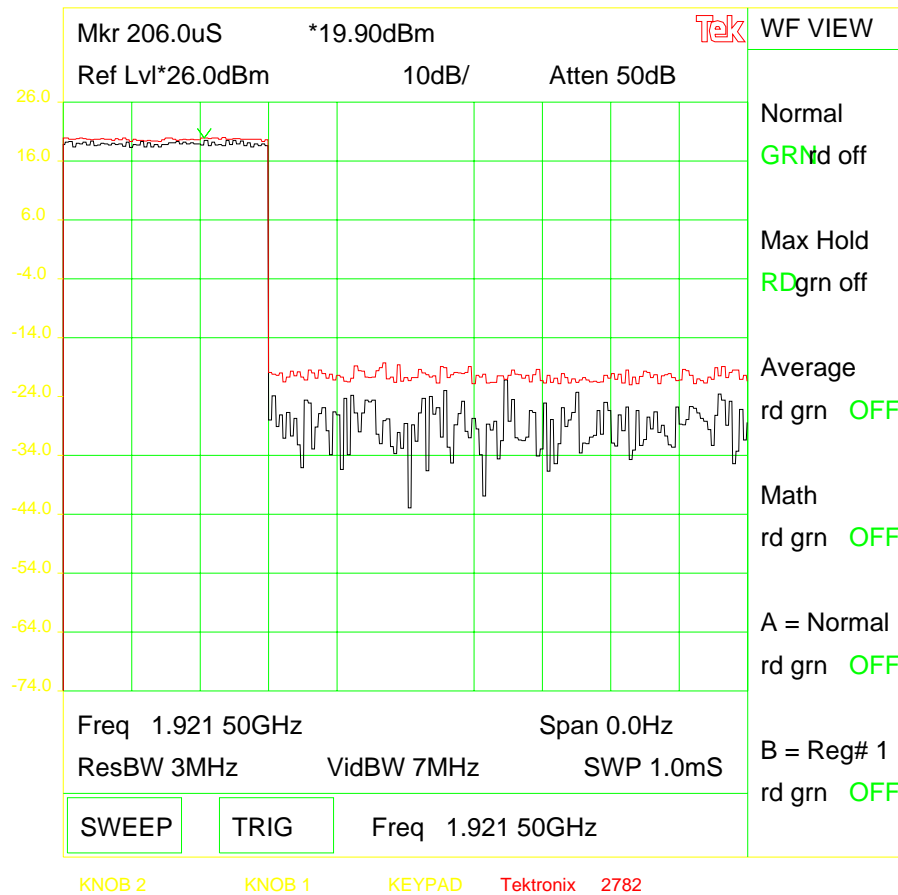



Peak Transmit Power of MS at CH3

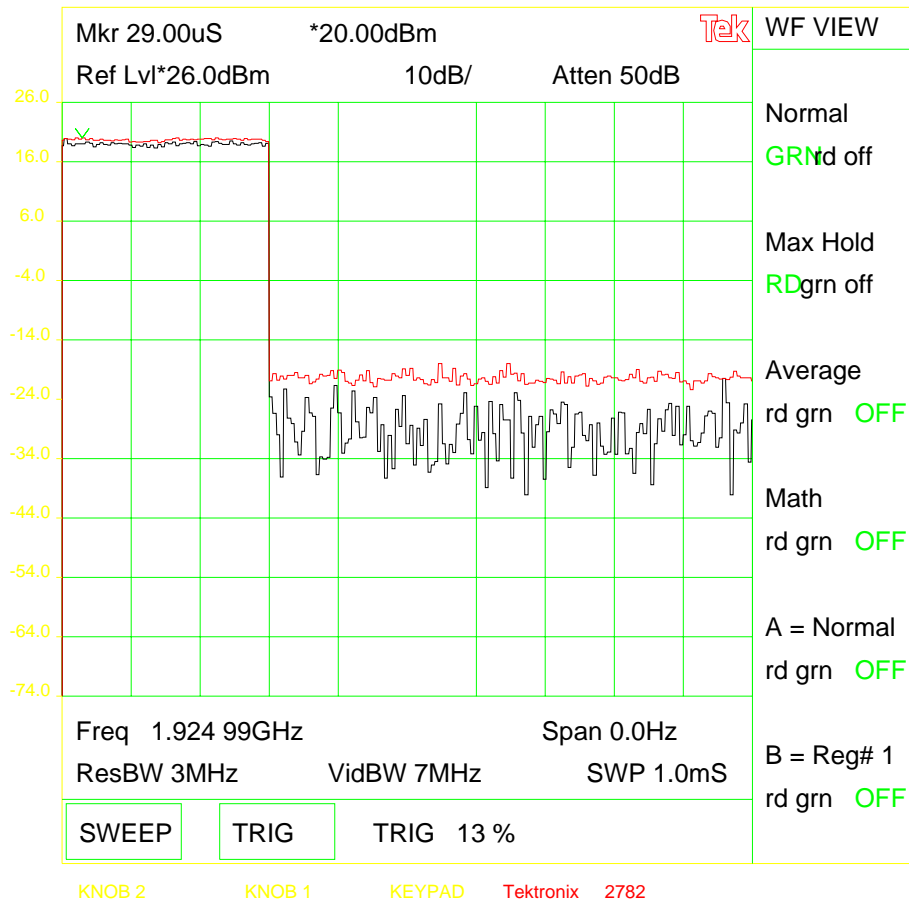

Peak Transmit Power of BS at CH5

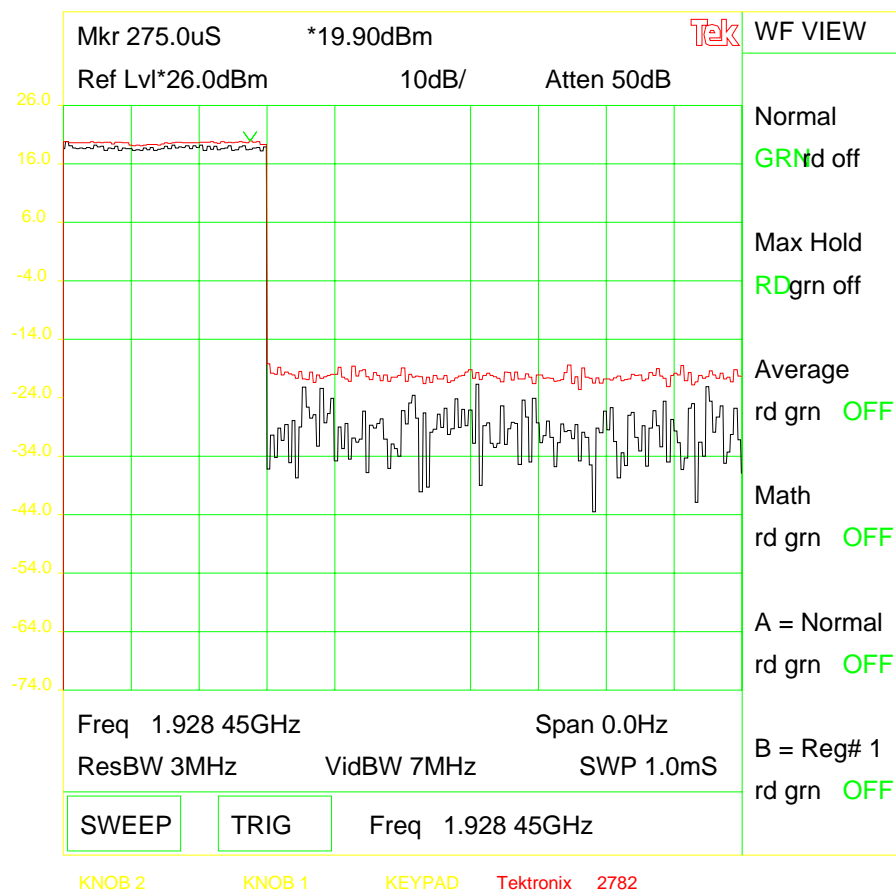

The following results are measured:

Peak Transmit Power	Measurement	Result
CH1	19.9 dBm	Pass
CH3	20.0 dBm	Pass
CH5	19.9 dBm	Pass

**Result: Pass**

## 4.6 Power Spectral density

### 4.6.1 Test Criteria

§ 15.319 General technical requirements.

(d) Power spectral density shall not exceed 3 milliwatts in any 3 kHz bandwidth as measured with a spectrum analyzer having a resolution bandwidth of 3 kHz.

### 4.6.2 Test procedure

Testing to ANSI C63.17 draft ballot 3.0 Clause 6.1.5, which provides the test methodology for this provision. In order to achieve pseudo random data transfer, as in reality, a connection is setup between the EUT and a Rhode and Schwarz DECT Test Device, the CMD 65.

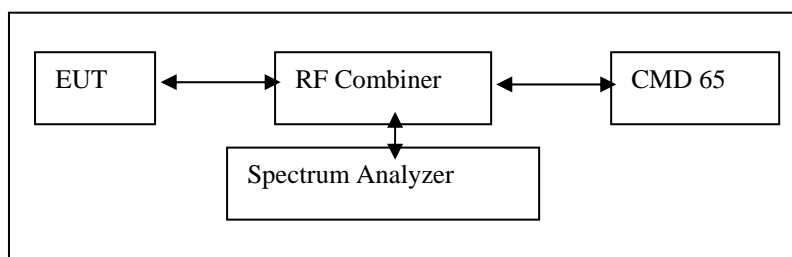

The CMD settings are shown below:

Traffic Carrier Offset	-20
Frequency Channel	4
Traffic Slot	2
RF Level	-70dBm
Data Type	PRBS

The spectrum analyzer is setup according to ANSI C63.17 Clause 6.1.5:

Centre Frequency	CH1, CH3, CH5
RBW	3KHz
VBW	3KHz
Trigger	Free Run
Span	10KHz
Detection	Peak Detection
Sweep Rate	20ms
Amplitude Scale	Log
Peak Hold	On

The power spectral density of the MS is measured at 25°C and frequency channel CH1, CH3 and CH5.

According to Part 15.319 (d) the maximum allowable Power Spectral Density is 3mW

$$PSD_{\text{limit}} = 3\text{mW} = 4,8\text{dBm}$$

## 4.6.3 Test Results

CH1:

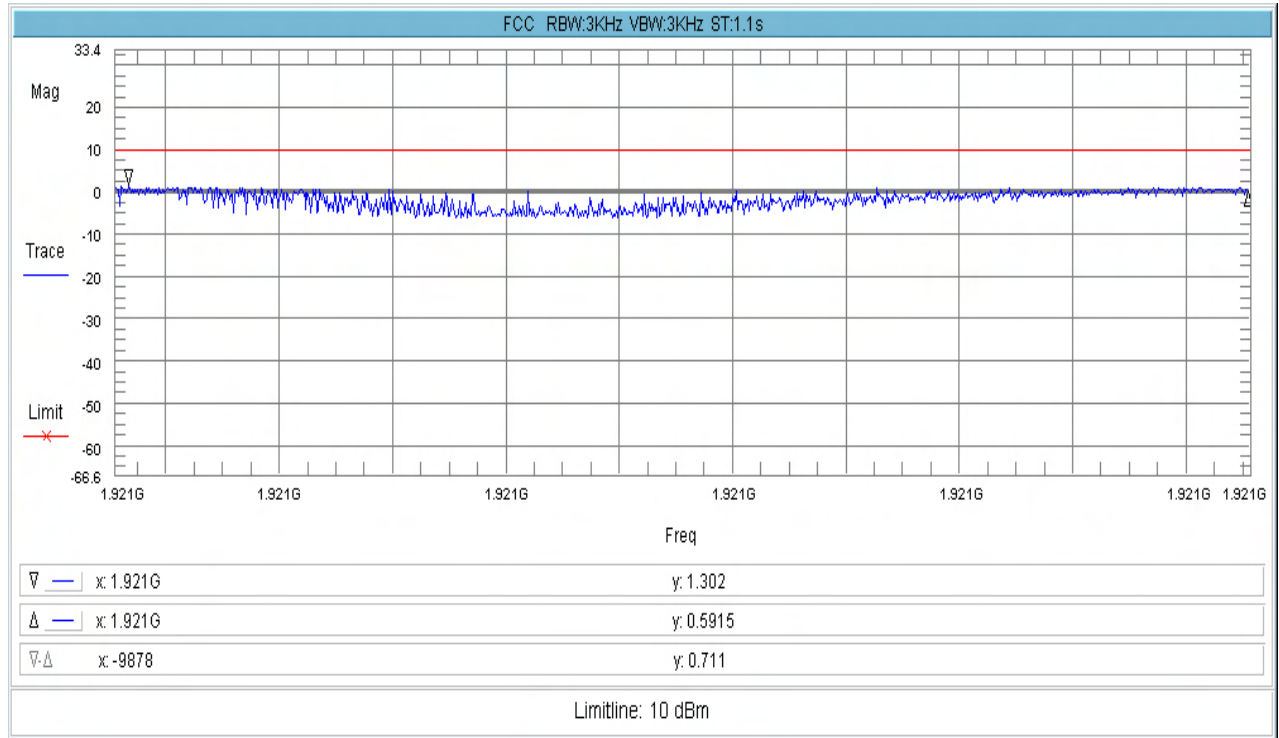

CH3:

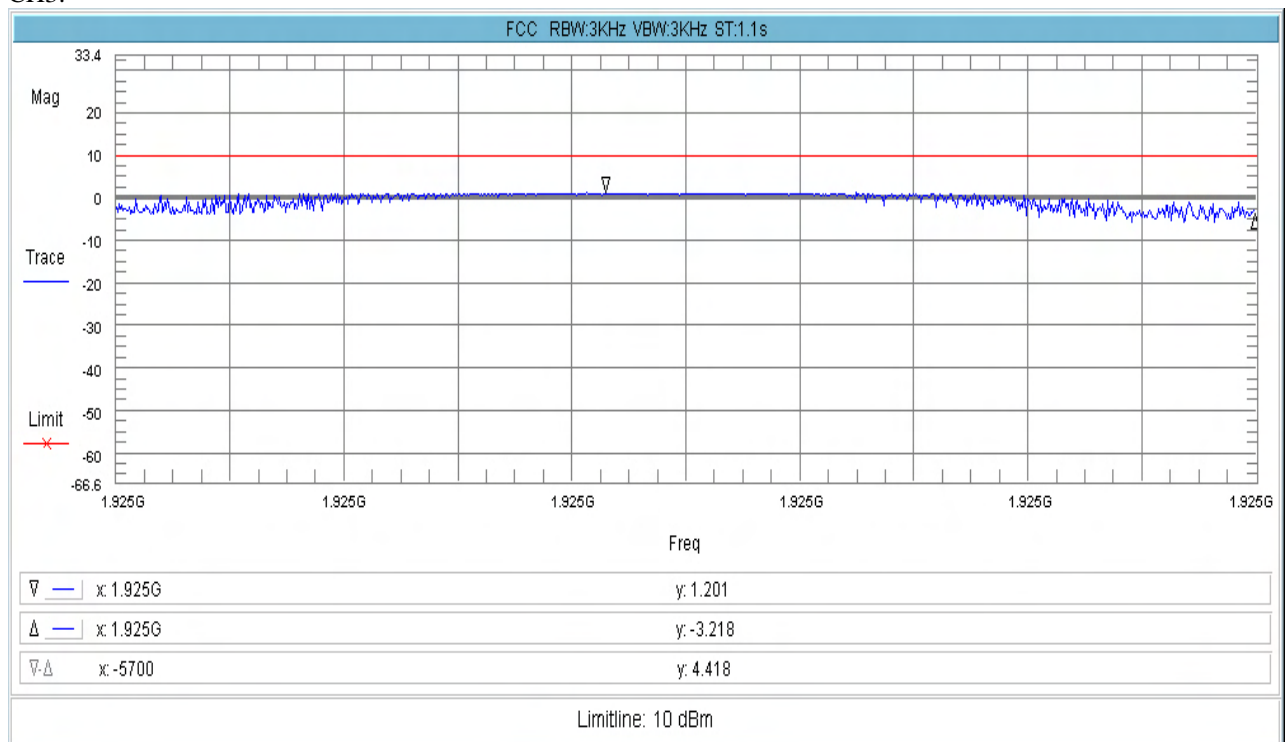

CH5:

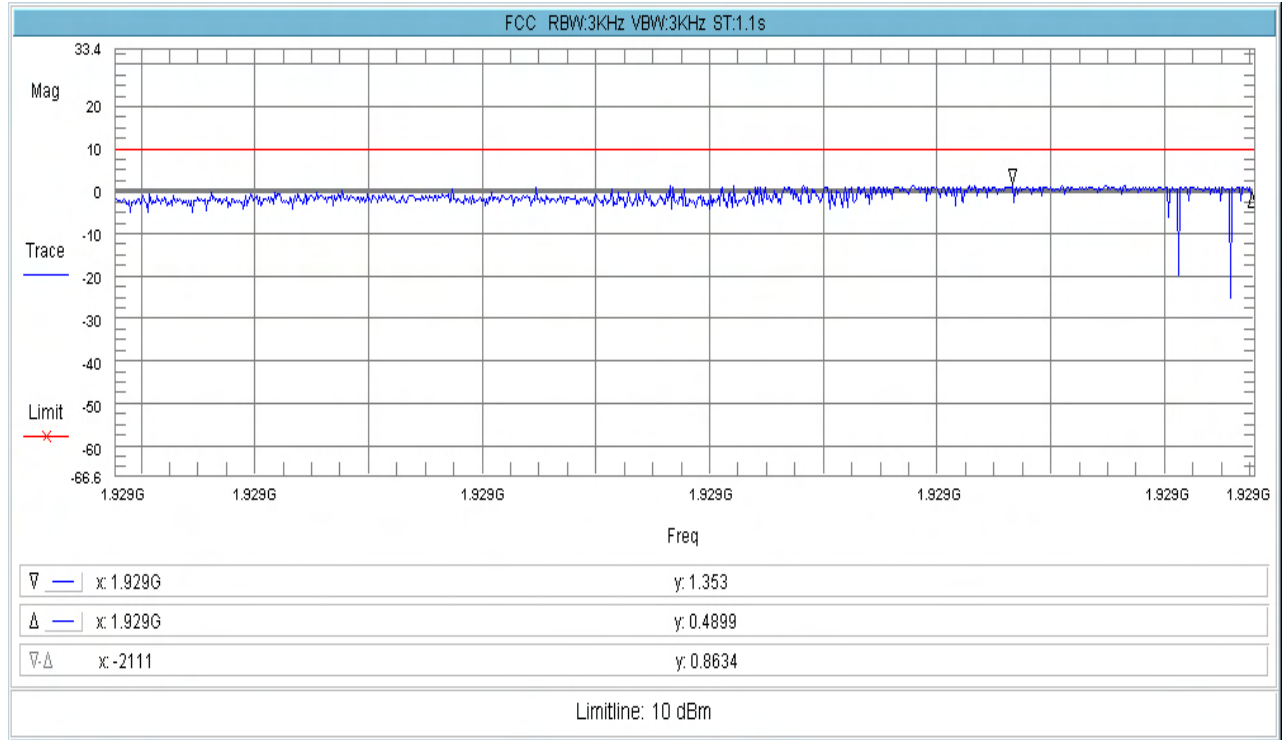

The following results are measured:

Power Spectral Density	Measurement	Result
CH1	1.35 mW/3KHz	Pass
CH3	1.26 mW/3KHz	Pass
CH5	1.36 mW/3KHz	Pass

**Result: Pass**

## 4.7 Power Adjustment for Antenna Gain

### 4.7.1 Test Criteria

§ 15.319 General technical requirements.

(e) The peak transmit power shall be reduced by the amount in decibels that the maximum directional gain of the antenna exceeds 3 dBi.

### 4.7.2 Test Procedure

The antenna gain of the MS is measured in an anechoic room.

### 4.7.3 Test Results

The antenna is separated from the rf frontend and connected to external coax cable.

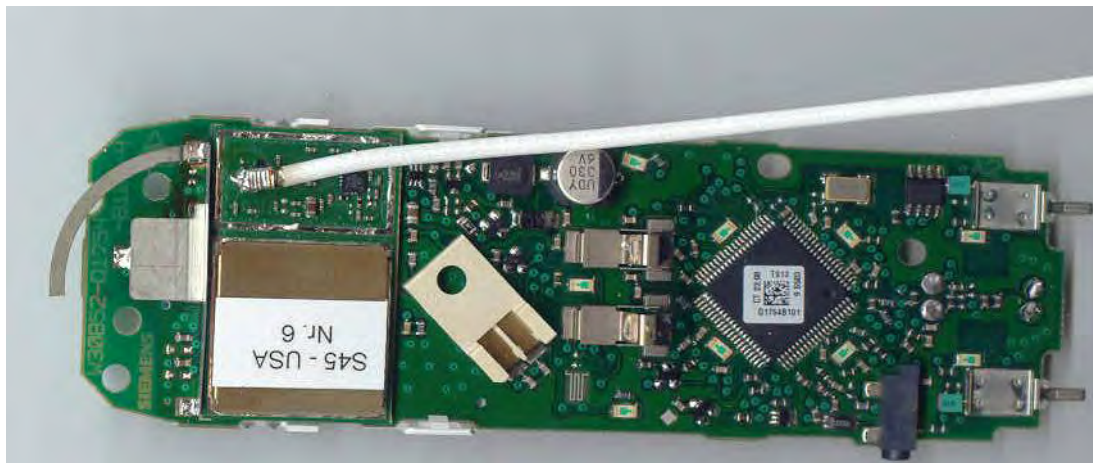

### Inverted-F MS Antenna

	Vert. Ant	Hor. Ant
Min.	-8,4	-18,8
Max.	-4,3	-2,0

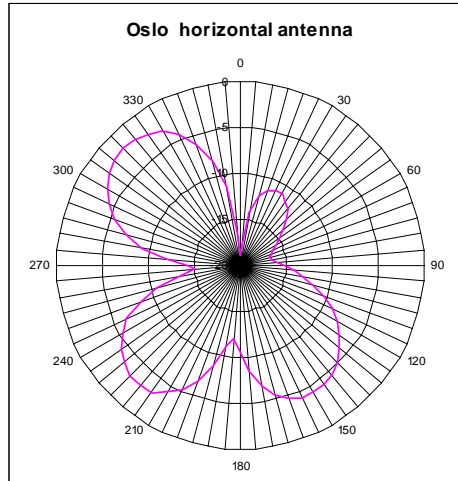
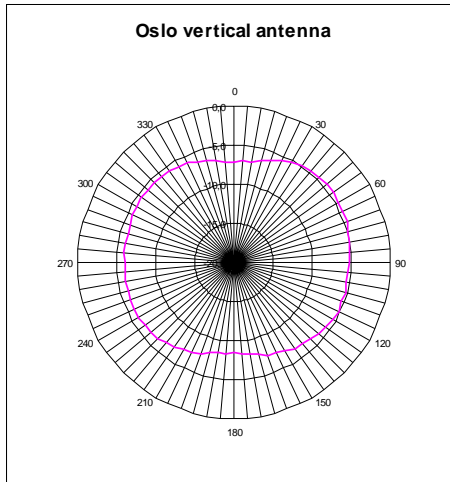

The antenna measurements are summarized below:

	<b>Inverted-F Antenna</b>
Max Vert. Gain	-4.3 dBi
Max Hor. Gain	-2.0 dBi

**Result: The maximum antenna gain < 3dBi.**

## 4.8 Automatically Discontinued Transmission

### 4.8.1 Test Criteria

**Section 15.319 General technical requirements.**

**(f) The device shall automatically discontinue transmission in case of either absence of information to transmit or operational failure. These provisions are not intended to preclude transmission of control and signaling information or use of repetitive codes used by certain digital technologies to complete frame or burst intervals.**

### 4.8.2 Test Procedure

Attestation of manufacturer supported by test results. The statement shall include a description of how the EUT operates when there is no data to transmit. This may be met by reference to relevant portions of the DECT standards. The supporting testing is as follows:

The following tests are performed after a connection is first established between the EUT and its companion device.

	Test	Reaction at EUT	Result
1	Remove Power from companion device.	A/B/C	Pass/Fail
2	Switch off the companion device.	A/B/C	Pass/Fail
3	Terminate call at the companion device.	A/B/C	Pass/Fail
4	Switch off the EUT.	A/B/C	Pass/Fail
5	Terminate call at the EUT.	A/B/C	Pass/Fail

A – Connection is terminated and transmission ceases.

B – Connection is terminated but the EUT transmits control or signaling information

C – Connection is terminated but the companion device transmits control or signaling information

### 4.8.3 Test Result

The following testing is performed to confirm compliance with this provision :

	Test	Reaction at EUT	Result
1	Remove Power from companion device.	A	PASS
2	Switch off the companion device.	A	PASS
3	Terminate call at the companion device.	A	PASS
4	Switch off the EUT.	A	PASS
5	Terminate call at the EUT.	A	PASS

This device meets the requirement for automatic discontinuous operation. Its compliance with the DECT standards assures that transmissions are stopped when data is not available. See:

- ETSI EN 300 173-3, chapter 11.5.1: RFPI handshake
- ETSI EN 301 406, chapter 4.5.10.3: Channel release

**Result: PASS**



## 4.9 Spurious Emissions & Out of Band Emissions

### 4.9.1 Test Criteria

#### 4.9.1.1 Out of Band Emissions

§ 15.323 Specific requirements for isochronous devices operating in the 1920–1930 MHz sub-band.

(d)(1) Emissions shall be attenuated below a reference power of 112 milliwatts as follows: 30 dB between the band edge and 1.25 MHz above or below the band; 50 dB between 1.25 and 2.5 MHz above or below the band; and 60 dB at 2.5 MHz or greater above or below the band.

#### 4.9.1.2 Spurious and In-Band Unwanted Emissions

(d)(2) Emissions inside the band must comply with the following emission mask: In the bands between 1B and 2B measured from the center of the emission bandwidth, the total power emitted by the device shall be at least 30 dB below the transmit power permitted for that device; in the bands between 2B and 3B measured from the center of the emission bandwidth, the total power emitted by an intentional radiator shall be at least 50 dB below the transmit power permitted for that radiator; in the bands between 3B and the band edge, the total power emitted by an intentional radiator in the measurement bandwidth shall be at least 60 dB below the transmit power permitted for that radiator. “B” is defined as the emission bandwidth of the device in hertz. Compliance with the emission limits is based on the use of measurement instrumentation employing peak detector function with an instrument resolution bandwidth approximately equal to 1.0 percent of the emission bandwidth of the device under measurement.

## 4.9.2 Test Procedure

Testing to ANSI C63.17 draft ballot 3.0 Clause 6.1.6, which provides the test methodology for this provision.<sup>1</sup>

This test procedure for the spurious in-band and out-of-band emissions evaluates the frequency range 1905MHz to 1945MHz. The whole frequency range 9KHz up to 25GHz is supplied in a separate document.

The EUT is controlled from a personal computer and set into continuous transmission mode.

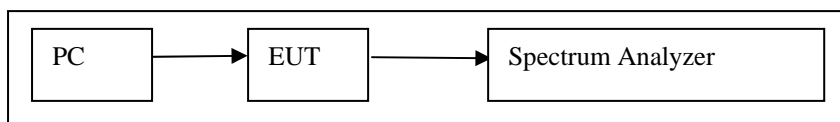

The spectrum analyzer is setup according to ANSI C63.17 Clause 6.1.6:

Centre Frequency	CH1, CH3, CH5
RBW	20KHz
VBW	100KHz
Trigger	Free Run
Span	20MHz in-band, 40MHz out-of-band
Detection	Peak Detection
Sweep Rate	auto
Amplitude Scale	Log
Peak Hold	On

The spurious emission of the MS is measured at 25°C and frequency channels CH1, CH3 and CH5.

The following limits apply:

	Out of Band Emissions	Spurious and In Band Unwanted Emissions
B	2.1 MHz	2 MHz
Peak Power	20.5 dBm	21.6 dBm
-30dB	Band Edge - 1.25 MHz	2 – 4 MHz
-50dB	1.25 – 2.5 MHz	4 – 6 MHz
-60dB	> 2.5 MHz	> 6 MHz

<sup>1</sup> Where these limits are more stringent than 47 CFR 15, Subpart C, §15.209, the limits of 47 CFR 15, Subpart C, §15.209 take precedence as indicated in 47 CFR 15, Subpart D, §15.319 (g).

## 4.9.3 Test Results

### 4.9.3.1 Out of Band Emissions

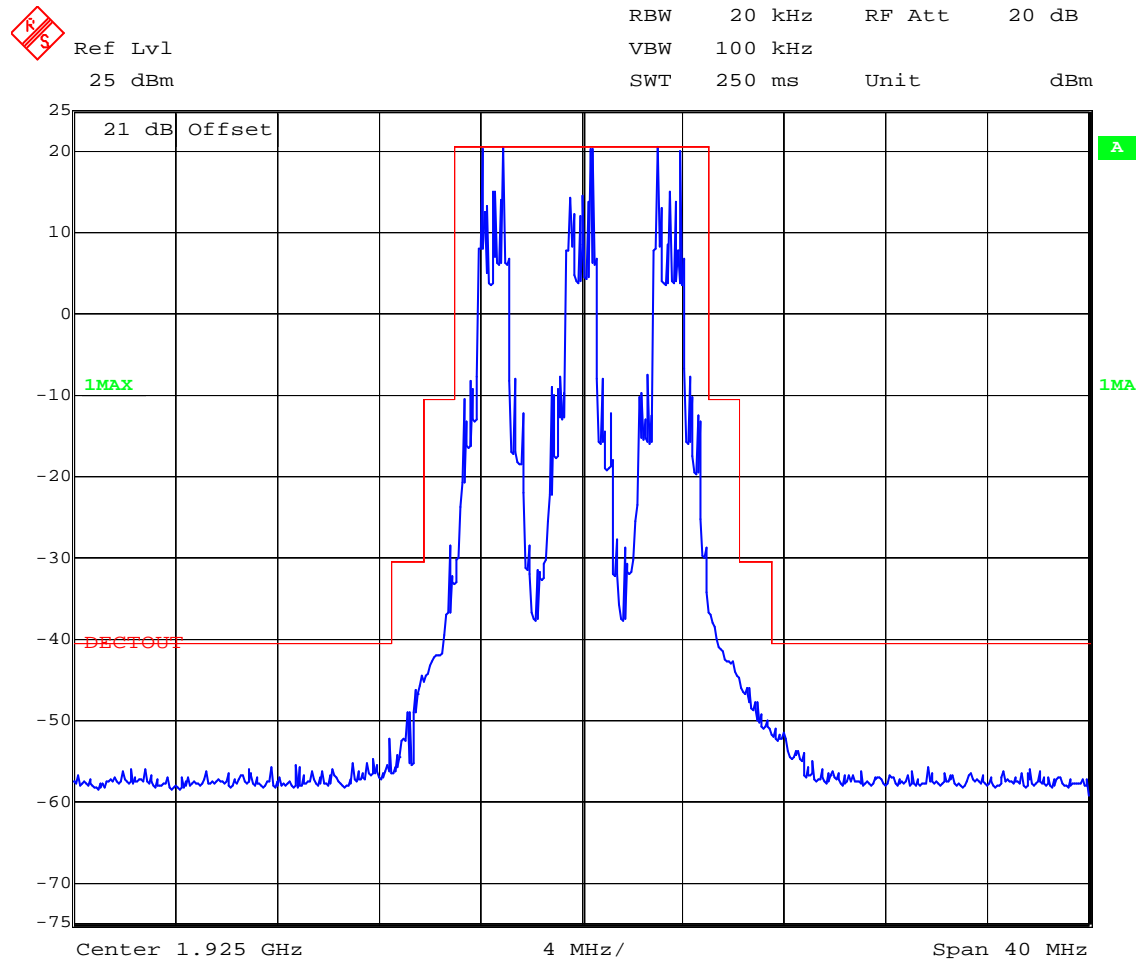

Date: 31.JAN.2006 10:37:42

**The MS spurious out-of-band emission level is below the indicated limit.**

**Result: Pass**

## 4.9.3.2 Spurious and In-Band Unwanted Emissions

CH1:



Ref Lvl	RBW	20 kHz	RF Att	20 dB
25 dBm	VBW	100 kHz	Unit	dBm
	SWT	125 ms		

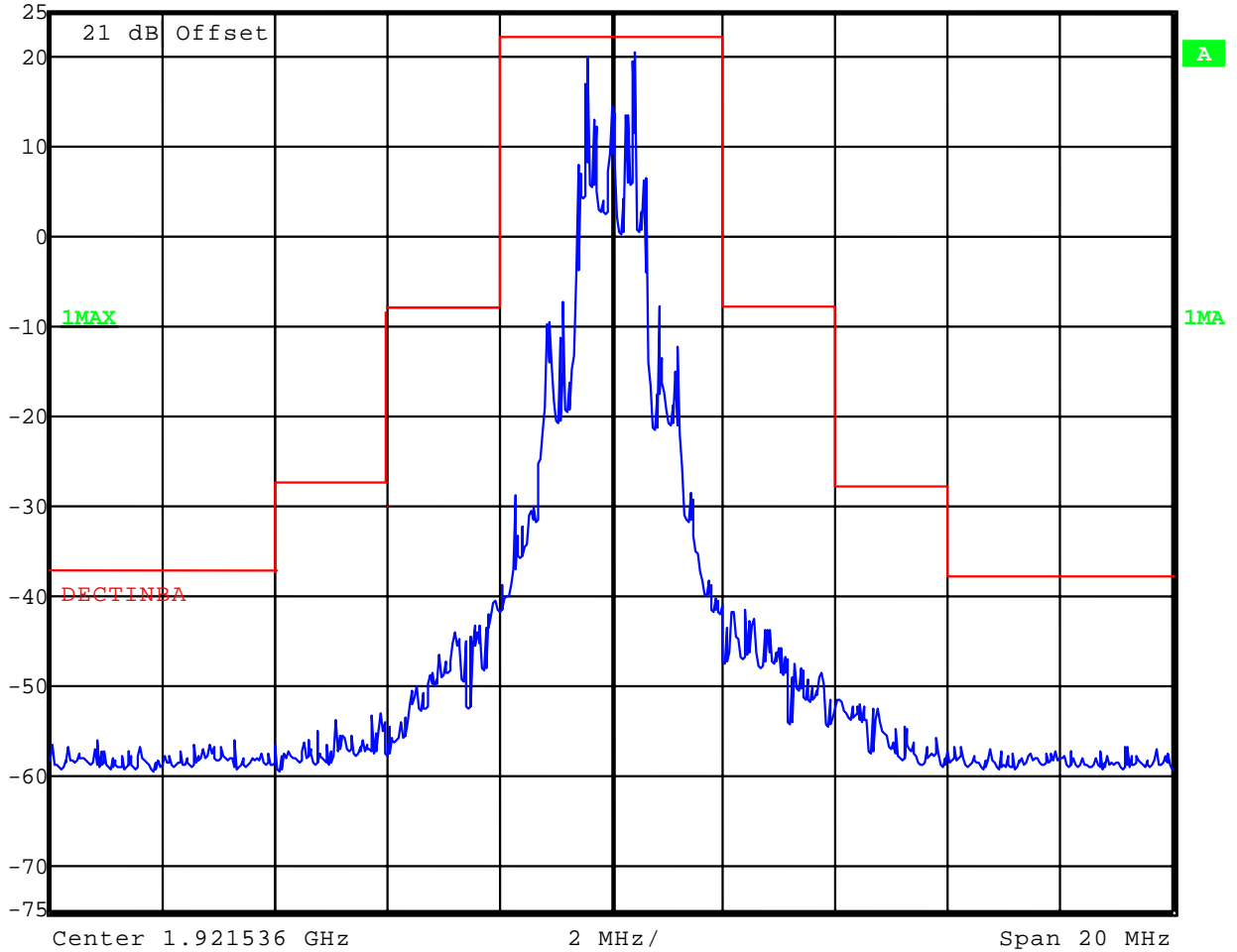

Date: 31.JAN.2006 10:33:47

CH3:



Ref Lvl	RBW	20 kHz	RF Att	20 dB
25 dBm	VBW	100 kHz	Unit	dBm
	SWT	125 ms		

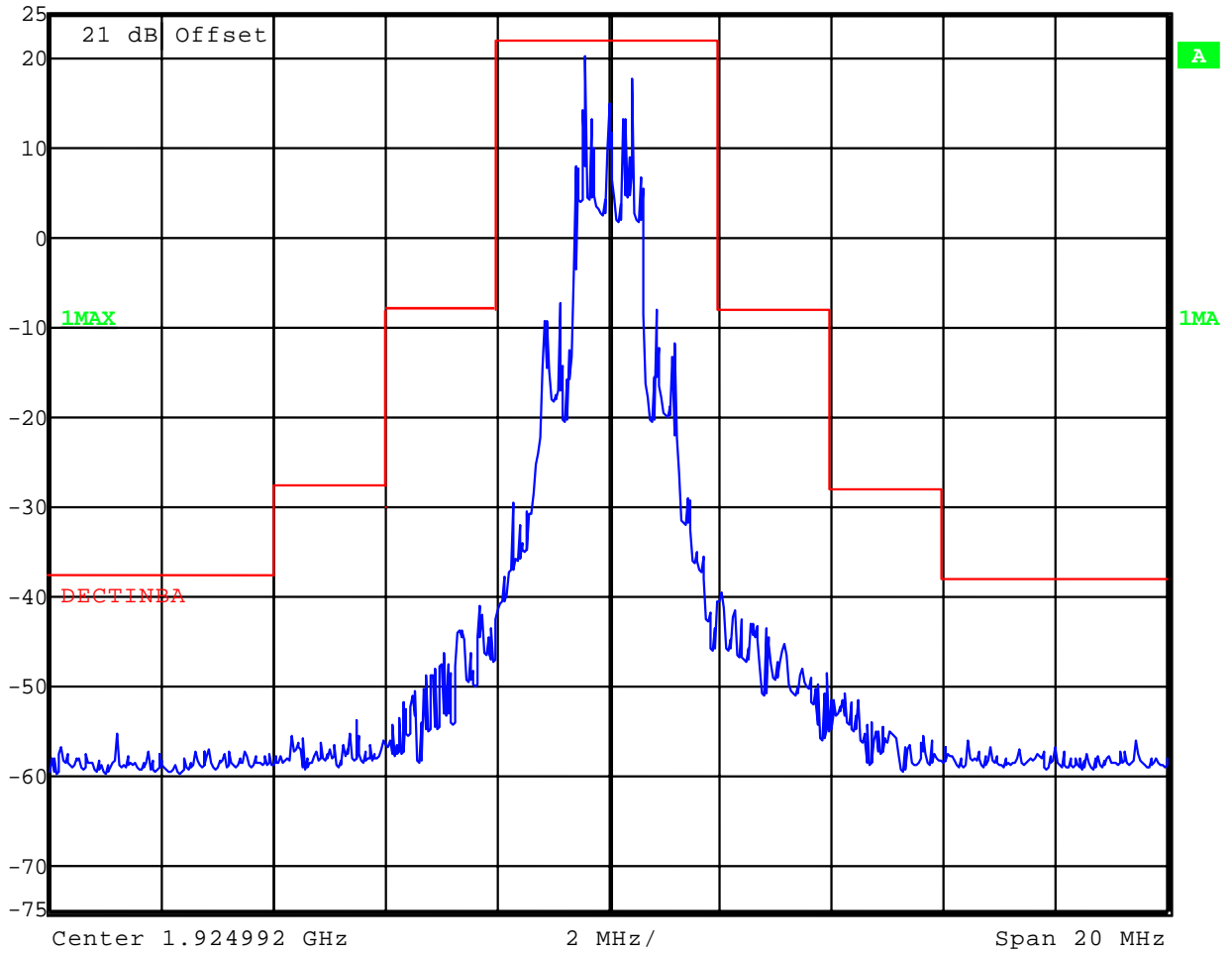

Date: 31.JAN.2006 10:31:20

CH5:

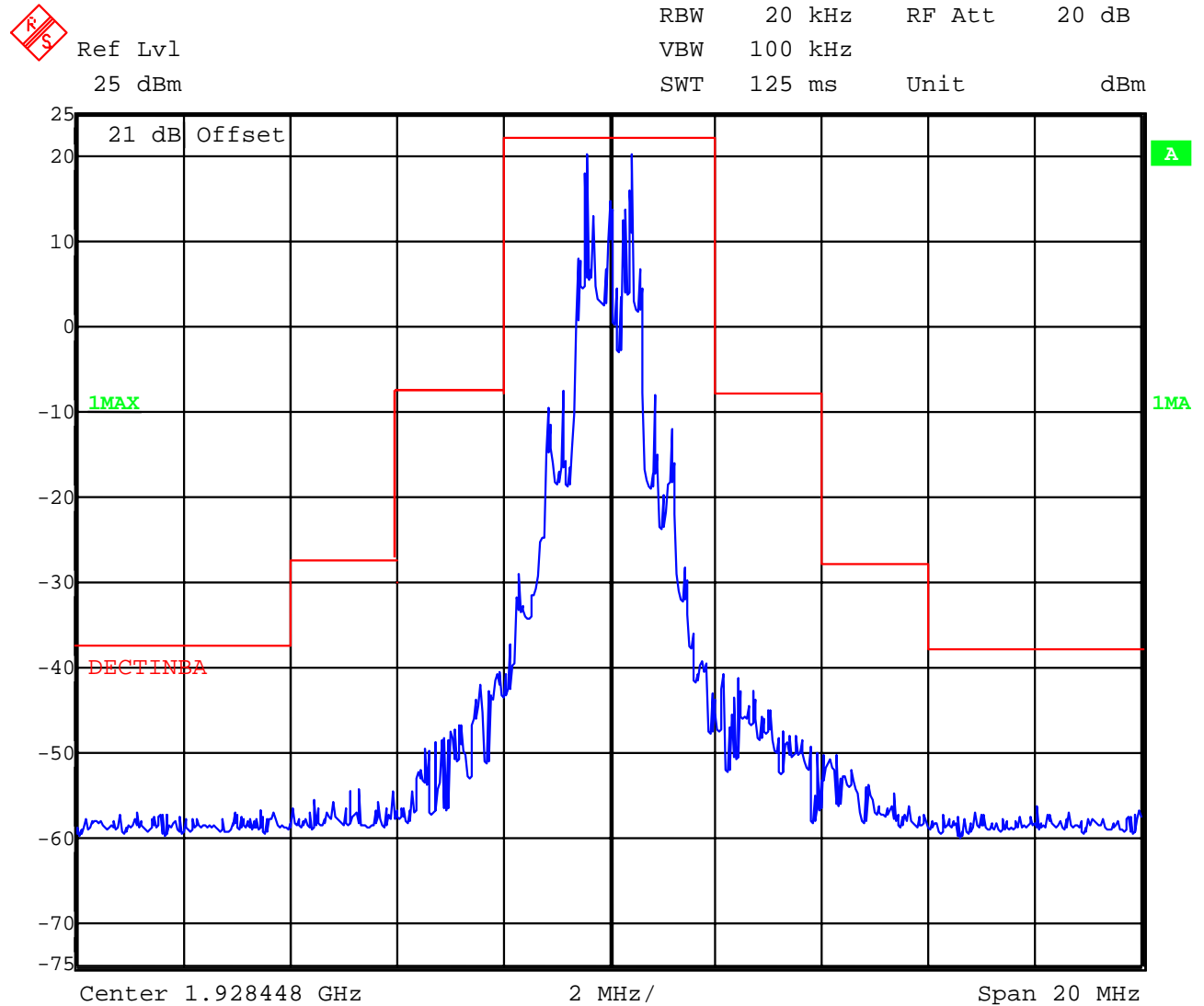

Date: 31.JAN.2006 10:32:54

**The MS spurious in-band emission level is below the indicated limit.**

**Result: Pass**

## **4.10 Listen Before Talk**

### **4.10.1 Test Criteria**

§ 15.323 Specific requirements for isochronous devices operating in the 1920–1930 MHz sub-band.

### **4.10.2 Test Procedure**

This requirement is split up into separate requirements which are covered by section 4.9 and sections 4.11 – 4.28.

### **4.10.3 Attestation**

This requirement is met by section 4.9 and sections 4.11 – 4.28.

**Result: Pass**

## 4.11 Monitoring Time

### 4.11.1 Test Criteria

§ 15.323 Specific requirements for isochronous devices operating in the 1920–1930 MHz sub-band.

(c) Isochronous devices must incorporate a mechanism for monitoring the time and spectrum windows that its transmission is intended to occupy. The following criteria must be met:

(1) Immediately prior to initiating transmission, devices must monitor the combined time and spectrum windows in which they intend to transmit for a period of at least 10 milliseconds for systems designed to use a 10 milliseconds or shorter frame period or at least 20 milliseconds for systems designed to use a 20 milliseconds frame period.

### 4.11.2 Test Procedure

Testing to ANSI C63.17 draft ballot 3.0 Clause 7.3.4, which provides the test methodology for this provision.

The following test setup is used:

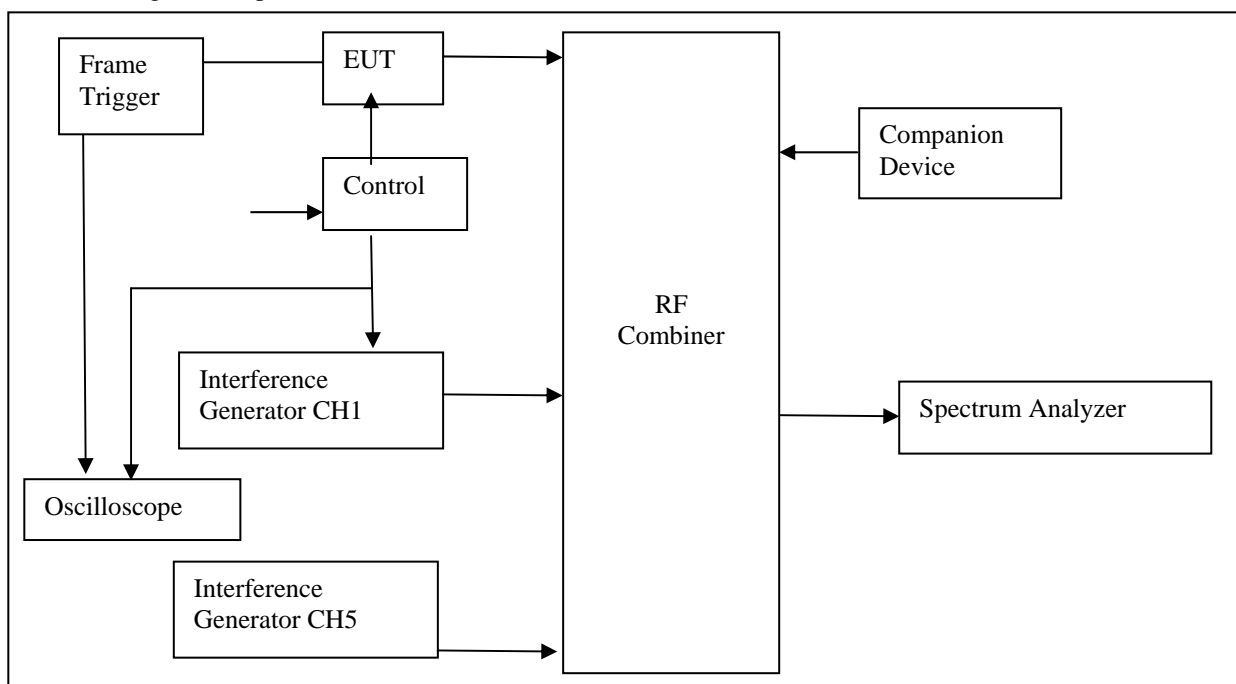

The following test procedure is applied:

ANSI C63.17	Description
Clause 7.3.4 (a)	Restrict transmission to CH1 and CH5 only. Set CW interference on CH5 to a level of -60dBm. ( $T_U+1$ dB)
Clause 7.3.4 (b)	Switch ON BS and verify transmission of control signals on CH1. Switch OFF BS.
Clause 7.3.4 (c)	Apply CW interference on CH1 at a level of -60dBm ( $T_U+1$ dB).
Clause 7.3.4 (d)	Remove interference from CH5 and immediately switch ON BS. Verify transmission of control signals on CH5 within 20ms.

The oscilloscope display is showing the CH5 rf disable signal and the frame sync signal from the MS. As soon as the frame sync signal appears a communication link should be setup on CH5. The communication link frequency is seen on the spectrum analyzer.



## 4.11.3 Test results

The oscilloscope display is shown below:

Tek Running: Waiting for Trigger

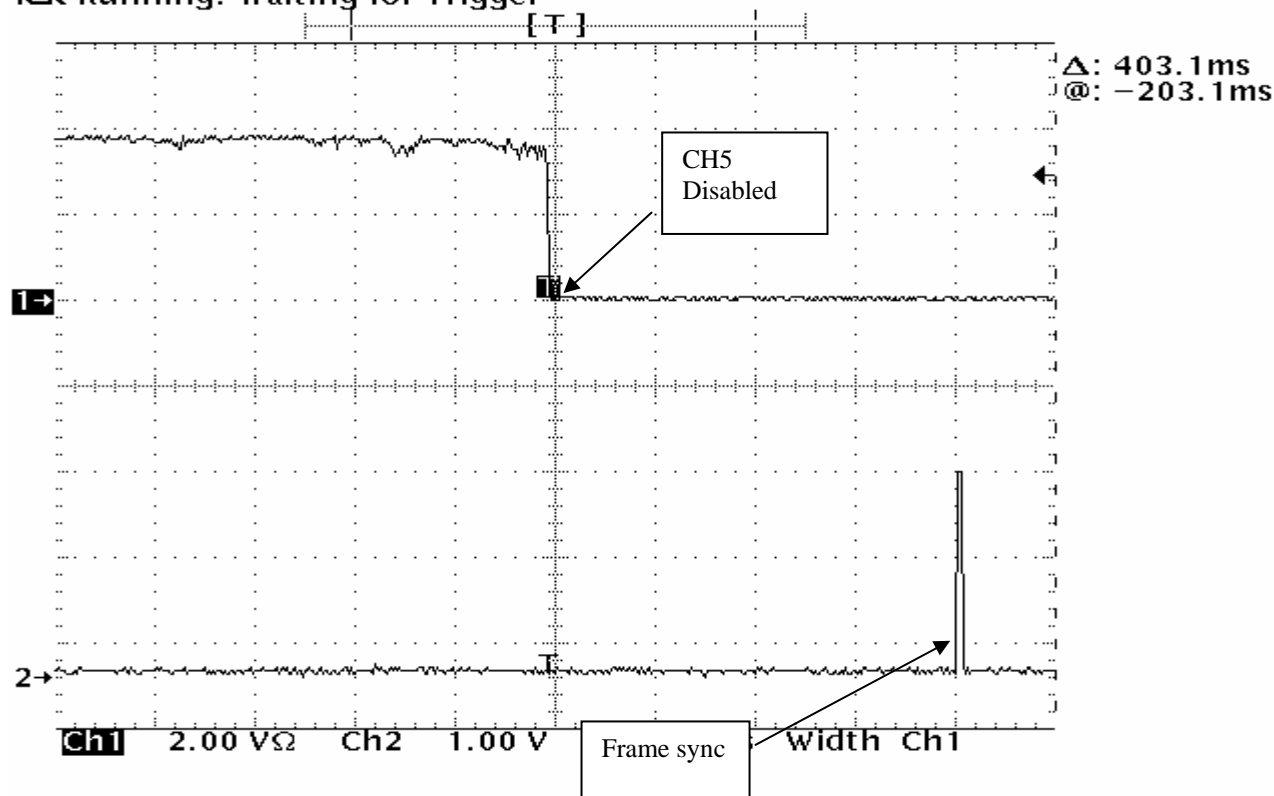

The difference between interference on CH5 disabled and starting of frames sync is 19.4ms.

The following test results are obtained:

ANSI C63.17	Description	Result
Clause 7.3.4 (a)	Transmission is restricted to CH1 and CH5 only. CW Interference on CH5 to a level of -60dBm. MS and BS are synchronized on Ch1.	Pass
Clause 7.3.4 (b)	Communication link between MS and BS on Ch1. Terminate the link	Pass
Clause 7.3.4 (c)	Apply interference on CH1 at a level of -60dBm.	Pass
Clause 7.3.4 (d)	Remove interference from CH5 and immediately initiate a communication link. 19.2 ms after rf disable the frame sync signal appears, indicating communication link setup on CH5.	Pass

**Result: Pass**

## 4.12 Monitoring Threshold

### 4.12.1 Test Criteria

§ 15.323 Specific requirements for isochronous devices operating in the 1920–1930 MHz sub-band.

(c) Isochronous devices must incorporate a mechanism for monitoring the time and spectrum windows that its transmission is intended to occupy. The following criteria must be met:

(2) The monitoring threshold must not be more than 30 dB above the thermal noise power for a bandwidth equivalent to the emission bandwidth used by the device.

### 5.12.2 Test Procedure

Testing to ANSI C63.17 draft ballot 3.0 Clause 7.3.1, which provides the test methodology for this provision. The Clause states that the lower threshold is for devices that do not use the LIC procedure.

The equation for the lower monitoring threshold is given in ANSI C63.17 Clause 4.3.4.

$$T_L \leq (-174 + 10\log B + M_L + P_{\max} - P_{EUT}) \text{ dBm}$$

$$B = 2.1 \text{ MHz}$$

$$M_L = 30\text{dB}$$

$$P_{\max} = P_{EUT}$$

$$T_L = -80.8\text{dBm}$$

### 5.12.3 Test Results

The GIGASET S45 utilizes a LIC procedure and transmits on the least interfered channel.

The Rf sensitivity of the product for a BER of  $1.10 \times 10^{-3}$  is measured at -93dBm. The LIC procedure will be applied starting at -93dBm input power.

The current product offers 12 duplex channels per frequency channel and therefore  $12 \times 5 = 60$  duplex channels in total. Hence Part §15.323(c)(5) applies.

**Result: Pass**

## 4.13 Maximum Transmit Time

### 4.13.1 Test Criteria

§ 15.323 Specific requirements for isochronous devices operating in the 1920–1930 MHz sub-band.  
 (c) Isochronous devices must incorporate a mechanism for monitoring the time and spectrum windows that its transmission is intended to occupy. The following criteria must be met:  
 (3) If no signal above the threshold level is detected, transmission may commence and continue with the same emission bandwidth in the monitored time and spectrum windows without further monitoring. However, occupation of the same combined time and spectrum windows by a device or group of cooperating devices continuously over a period of time longer than 8 hours is not permitted without repeating the access criteria.

### 4.13.2 Test Procedure

Testing to ANSI C63.17 draft ballot 3.0 Clause 8.2.2, which provides the test methodology for this provision.

A communication link is established between BS and MS in an anechoic room to prevent influence from other transmissions.

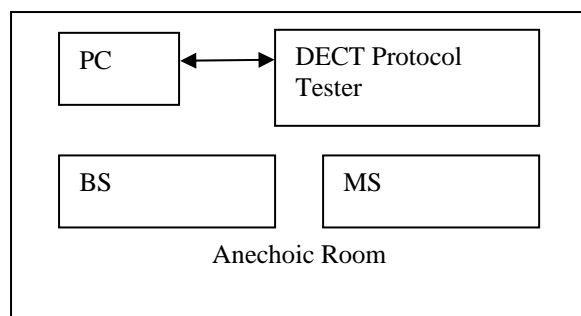

According to FCC Part 15.323 (c) (3), the access criteria have to be verified at least every 8 hours. The following test is performed:

ANSIC 63.17	Description
Clause 8.2.2 (a)	Initiate a communication link between BS and MS.
Clause 8.2.2 (b)	Monitor the communication channel. This link is monitored by a DECT protocol tester in an anechoic room to ensure no other DECT influence except for the existing communication link.

### 4.13.3 Test Results

	<b>Absolute Time</b>	<b>Time Difference</b>	<b>Result</b>
Initiate setup	17h30		n.a.
New Channel Access	17h47	2h55	n.a.
New Channel Access	20h42	2h55	Pass
New Channel Access	23h37	2h55	Pass
New Channel Access	2h32	2h55	Pass
New Channel Access	5h27	2h55	Pass
New Channel Access	8h22	2h55	Pass

The access criteria are verified every 2:55 hour. During this procedure the channel is changed.

**Result: Pass**

## 4.14 System Acknowledgement

### 4.14.1 Test criteria

§ 15.323 Specific requirements for isochronous devices operating in the 1920–1930 MHz sub-band.

(c) Isochronous devices must incorporate a mechanism for monitoring the time and spectrum windows that its transmission is intended to occupy. The following criteria must be met:

(4) Once access to specific combined time and spectrum windows is obtained an acknowledgment from a system participant must be received by the initiating transmitter within one second or transmission must cease. Periodic acknowledgments must be received at least every 30 seconds or transmission must cease. Channels used exclusively for control and signaling information may transmit continuously for 30 seconds without receiving an acknowledgment, at which time the access criteria must be repeated.

### 4.14.2 Test procedure

Testing to ANSI C63.17 draft ballot 3.0 Clause 8.2.1. , which provides the test methodology for this provision.

The following test setup is used:

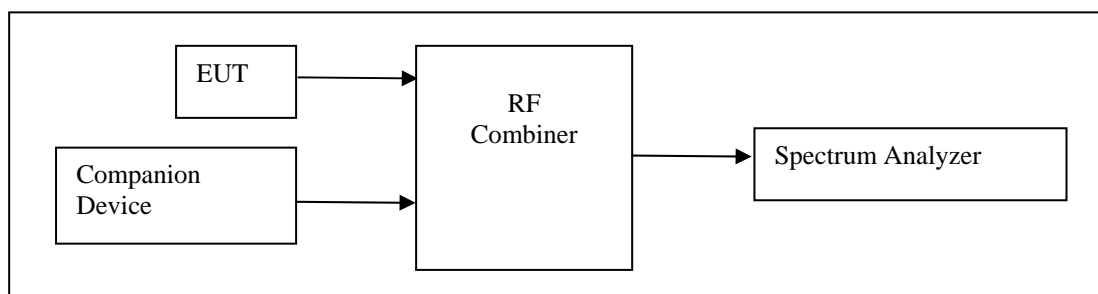

The MS is synchronized to the BS through the RF-combiner.

The following test procedure is performed:

ANSIC 63.17	Description
Clause 8.2.1 (a)	The frequency channel is restricted to Ch3 and the BS transmits control signals on Ch3. So a communication link can be set up.
Clause 8.2.1 (b)	Switch off the BS and verify initiating a communication link. Verify that the MS stops transmitting.
Clause 8.2.1 (c)	Enable the receiver of the BS and verify that a communication link can be build up.
Clause 8.2.1 (d)	With a communication link existing, turn off the BS and verify that the MS terminates transmission within 30 s.



## 4.15 Least Interfered Channel

### 4.15.1 Test Criteria

§ 15.323 Specific requirements for isochronous devices operating in the 1920–1930 MHz sub-band.

(c) Isochronous devices must incorporate a mechanism for monitoring the time and spectrum windows that its transmission is intended to occupy. The following criteria must be met:

(5) If access to spectrum is not available as determined by the above, and a minimum of 40 duplex system access channels are defined for the system, the time and spectrum windows with the lowest power level below a monitoring threshold of 50 dB above the thermal noise power determined for the emission bandwidth may be accessed.

### 4.15.2 Test procedure

Testing to ANSI C63.17 draft ballot 3.0 Clause 7.3.2. & 7.3.3, which provides the test methodology for this provision.

The current product offers 12 duplex channels per frequency channel and therefore 12x5=60 duplex channels in total. Hence Part §15.323(c)(5) applies.

The equation for the upper monitoring threshold is given in ANSI C63.17 Clause 4.3.3.

$$T_U \leq (-174 + 10\log B + M_U + P_{\max} - P_{EUT}) \text{ dBm}$$

$$B = 2.1 \text{ MHz}$$

$$M_U = 50\text{dB}$$

$$P_{\max} = P_{EUT}$$

$$T_U = -60.8 \text{ dBm}$$

#### 4.15.2.1 Upper Threshold

Testing to ANSI C63.17 draft ballot 3.0 Clause 7.3.2 (a), which provides the test methodology for this provision.

The following test setup is used:

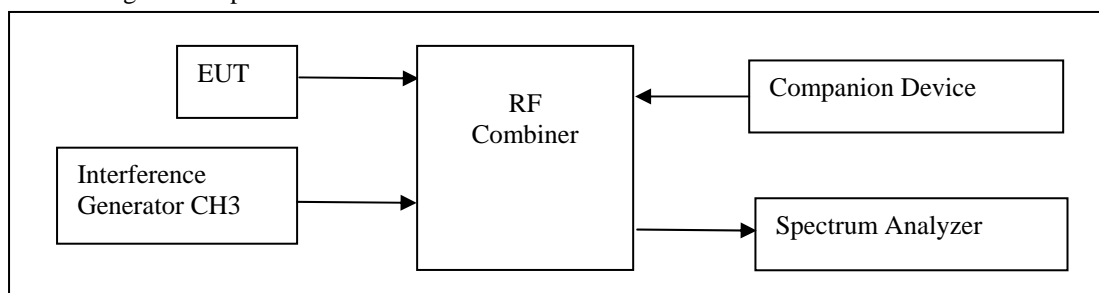

The following test procedure is applied:

ANSI C63.17	Description
Clause 7.3.2 (a)	<p>The MS is forced to operate on frequency channel CH3 only.</p> <p>The BS is set to Transmit its control signals at frequency channel Ch3.</p> <p>BS and MS are synchronized on Ch3.</p> <p>Apply CW interference at CH3 and at level -51dBm (<math>T_U + 10\text{dB}</math>).</p> <p>A communication link is initiated, forcing the MS to transmit on Ch3.</p> <p>Lower the interference level until the communication link can be set up on Ch3.</p> <p>Verify the communication link on spectrum analyzer.</p>

## 4.15.2.2 LIC Procedure

Testing to ANSI C63.17 draft ballot 3.0 Clause 7.3.3, which provides the test methodology for this provision.

The following test setup is used:

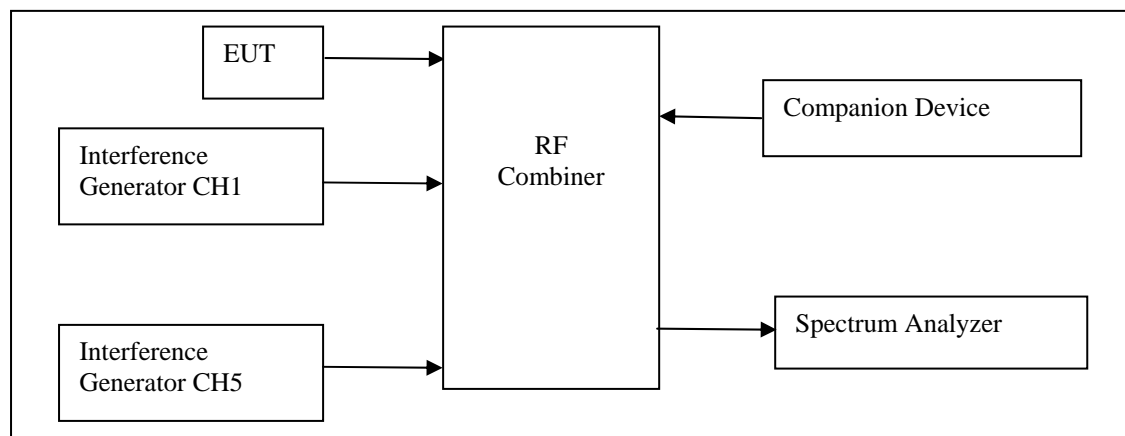

The following test procedure is applied:

ANSI C63.17	Description
Clause 7.3.3 (a)	The EUT is restricted to transmit on either CH1 or CH5.
Clause 7.3.3. (b)	Apply interference on CH1 at level $-74\text{dBm} (T_L + 7\text{dB})$ . Apply interference on CH5 at level $-81\text{dBm} (T_L)$ . Setup link between BS and MS 5 times and verify transmission on CH5.
Clause 7.3.3. (c)	Apply interference on CH1 at level $-81\text{dBm} (T_L)$ . Apply interference on CH5 at level $-74\text{dBm} (T_L + 7\text{dB})$ . Setup link between BS and MS 5 times and verify transmission on CH1.
Clause 7.3.3. (d)	Apply interference on CH1 at level $-80\text{dBm} (T_L + 1\text{dB})$ . Apply interference on CH5 at level $-87\text{dBm} (T_L - 6\text{dB})$ . Setup link between BS and MS 5 times and verify transmission on CH5.
Clause 7.3.3. (e)	Apply interference on CH1 at level $-87\text{dBm} (T_L - 6\text{dB})$ . Apply interference on CH5 at level $-80\text{dBm} (T_L + 1\text{dB})$ . Setup link between BS and MS 5 times and verify transmission on CH1.

**Verify the communication on the spectrum analyzer.**



## 4.15.3 Test Results

### 4.15.3.1 Upper Threshold

The BS is switched ON and the transmission of control signals is verified:

Interference Signal	Control Signal	Result
< -60.8dBm (-63 dBm)	YES	Pass
> -60.8 dBm	NO	Pass

In the next plot you see the interferer at -61 dBm

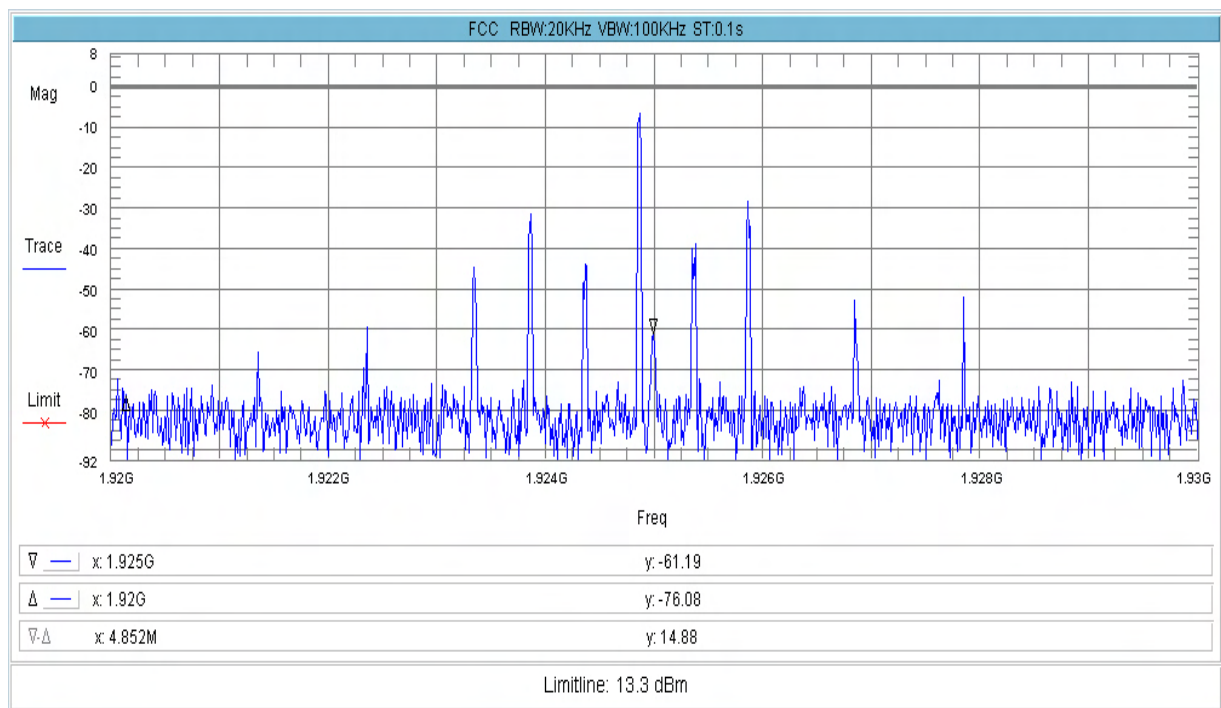

**Result: Pass**

### 4.15.3.2 LIC Procedure

The plot shows the two interferer.

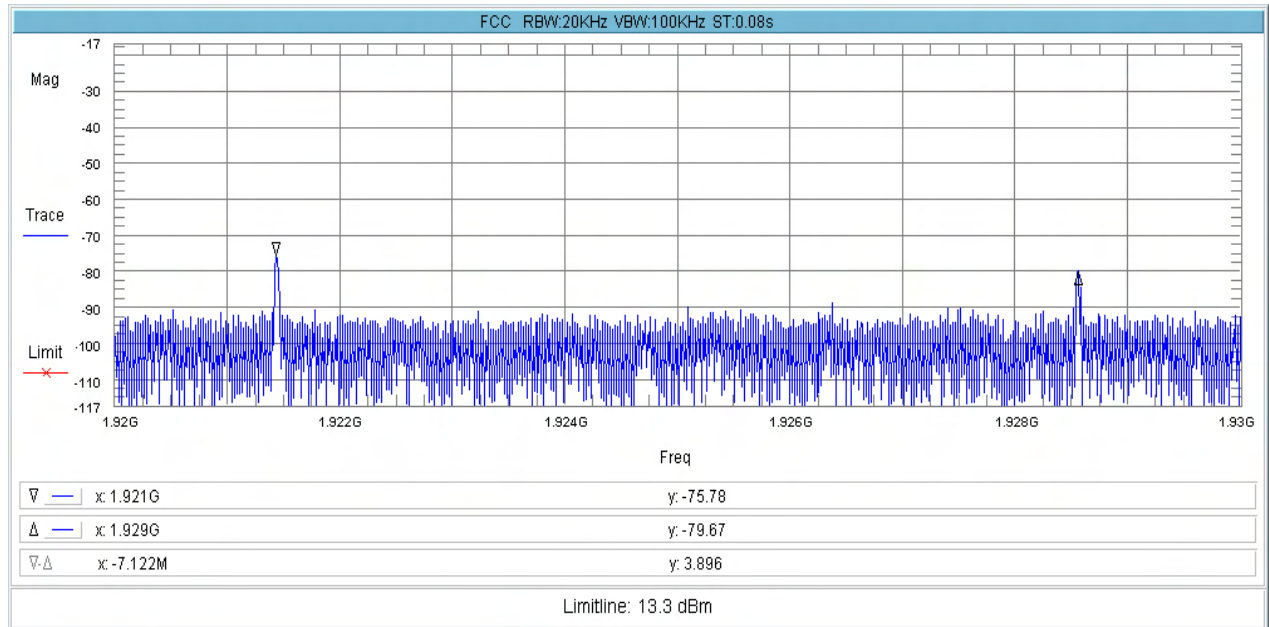

In this plot you see the communication on the least interfered channel including the interferer

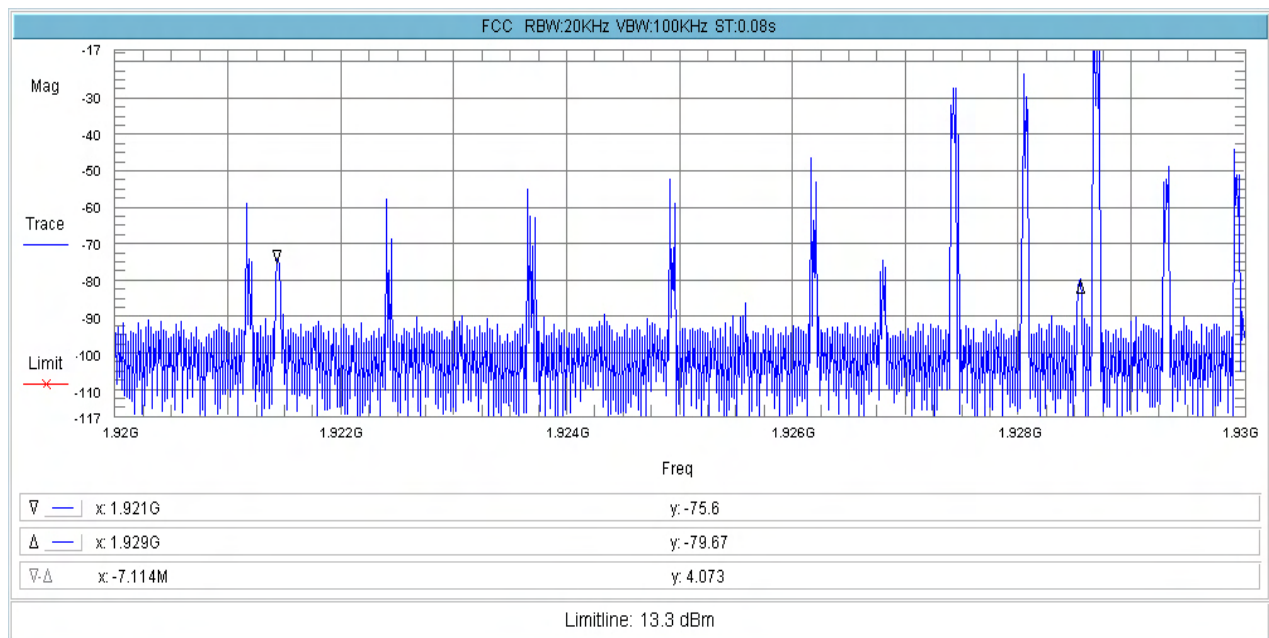

**The upper plot shows the two interference sources at CH1 and CH5. Interference source at CH1 is at -74dBm ( $T_L + 7dB$ ) and CH5 is at -81dBm ( $T_L$ ). The lower plot the BS accessing CH5 (LIC).**

The following test results are measured:

<b>ANSI C63.17</b>	<b>Description</b>	<b>Result</b>
Clause 7.3.3. (a)	The BS is restricted to CH1 or CH5.	Pass
Clause 7.3.3. (b)	5 x CH5 transmission of control signals	Pass
Clause 7.3.3. (c)	5 x CH1 transmission of control signals	Pass
Clause 7.3.3. (c)	5 x CH5 transmission of control signals	Pass
Clause 7.3.3. (d)	5 x CH1 transmission of control signals	Pass

**Result: Pass**

## 4.16 Channel Confirmation

### 4.16.1 Test Criteria

§ 15.323 Specific requirements for isochronous devices operating in the 1920–1930 MHz sub-band.

(c) Isochronous devices must incorporate a mechanism for monitoring the time and spectrum windows that its transmission is intended to occupy. The following criteria must be met:

(5) A device utilizing the provisions of this paragraph must have monitored all access channels defined for its system within the last 10 seconds and must verify, within the 20 milliseconds (40 milliseconds for devices designed to use a 20 milliseconds frame period) immediately preceding actual channel access that the detected power of the selected time and spectrum windows is no higher than the previously detected value.

### 4.16.2 Test Procedure

Testing to ANSI C63.17 draft ballot 3.0 Clause 7.3.3 & 7.3.4, which provides the test methodology for this provision.

### 4.16.3 Test results

This test was performed in section 4.11 and 4.15

**Result: Pass**

## **4.17 Power Measurement Resolution**

### **4.17.1 Test Criteria**

**§ 15.323 Specific requirements for isochronous devices operating in the 1920–1930 MHz sub-band.**

**(c) Isochronous devices must incorporate a mechanism for monitoring the time and spectrum windows that its transmission is intended to occupy. The following criteria must be met:**

**(5) The power measurement resolution for this comparison must be accurate to within 6 dB.**

### **4.17.2 Test procedure**

Testing to ANSI C63.17 draft ballot 3.0 Clause 7.3.3, which provides the test methodology for this provision.

### **4.17.3 Test Result**

The accuracy of the upper threshold is -2.2 dB

**Result: Pass**

## **4.18 Segment Occupancy**

### **4.18.1 Test Criteria**

**§ 15.323 Specific requirements for isochronous devices operating in the 1920–1930 MHz sub-band.**

**(c) Isochronous devices must incorporate a mechanism for monitoring the time and spectrum windows that its transmission is intended to occupy. The following criteria must be met:**

**(5) No device or group of cooperating devices located within 1 meter of each other shall occupy more than three 1.25 MHz channels during any frame period**

### **4.18.2 Test Procedure**

**Attestation of manufacturer supported by reference to relevant DECT specifications.**

### **4.18.3 Attestation**

**This device is compliant with the DECT standards described in European Standards EN 300 175-2 and EN 300 175-3. DECT transmissions are MC/TDMA/TDD (Multi carrier / Time Division Multiple Access / Time Division Duplex) using Digital GFSK modulation.**

**During any frame period cooperating devices will not occupy more than one channel bandwidth.**

**For further details see operational description or relevant portions of the DECT standards.**

## **4.19 Random Waiting**

### **4.19.1 Test Criteria**

**§ 15.323 Specific requirements for isochronous devices operating in the 1920–1930 MHz sub-band.**

**(c) Isochronous devices must incorporate a mechanism for monitoring the time and spectrum windows that its transmission is intended to occupy. The following criteria must be met:**

**(6) If the selected combined time and spectrum windows are unavailable, the device may either monitor and select different windows or seek to use the same windows after waiting an amount of time, randomly chosen from a uniform random distribution between 10 and 150 milliseconds, commencing when the channel becomes available.**

### **4.19.2 Test Procedure**

Testing to ANSI C63.17 draft ballot 3.0 Clause 8.1.3, which provides the test methodology for this provision.

### **4.19.3 Attestation**

**The option 15.323(c) (6) is not implemented by this product.**





## 4.21 Monitoring Reaction Time

### 4.21.1 Test Criteria

§ 15.323 Specific requirements for isochronous devices operating in the 1920–1930 MHz sub-band.

(c) Isochronous devices must incorporate a mechanism for monitoring the time and spectrum windows that its transmission is intended to occupy. The following criteria must be met:

(7) If a signal is detected that is 6 dB or more above the applicable threshold level, the maximum reaction time shall be  $35 \times \sqrt{f}$  (1.25/emission bandwidth in MHz) microseconds but shall not be required to be less than 35 microseconds.

### 4.21.2 Test Procedure

Testing to ANSI C63.17 draft ballot 3.0 Clause 7.5, which provides the test methodology for this provision.

The following test setup is used:

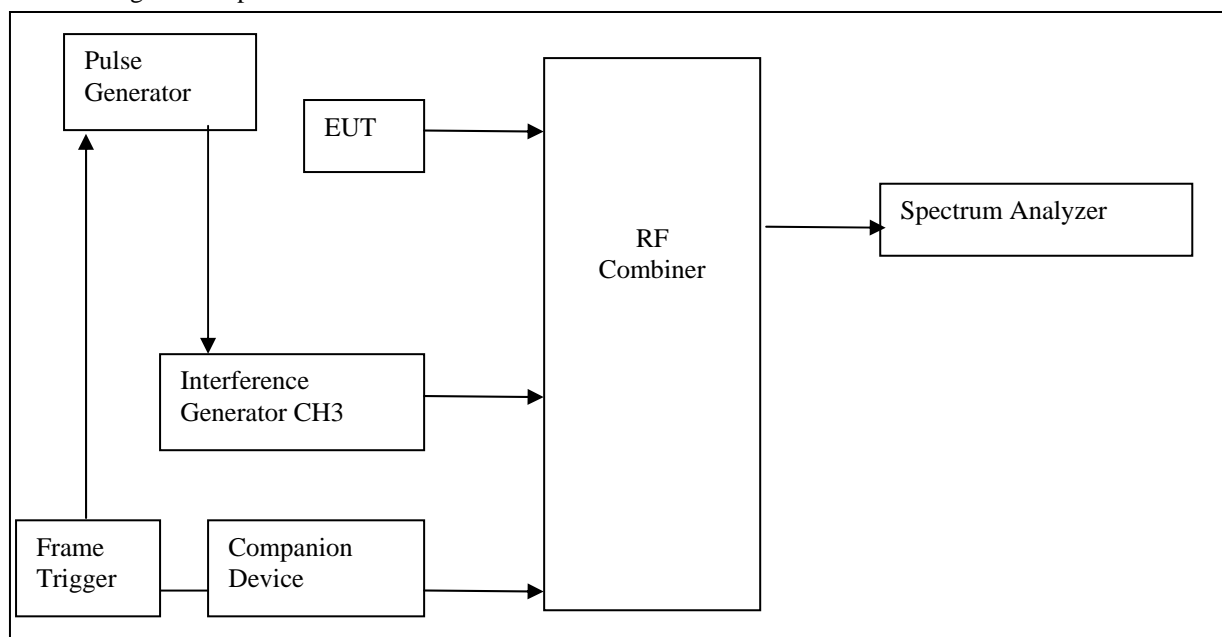

The following test procedure is applied:

ANSI C63.17	Description
Clause 7.5 (a)	The EUT is restricted to transmit on CH3 only. The BS is transmitting control signals on CH3. MS and BS are synchronized.
Clause 7.5 (b)	Apply synchronized CW pulsed interference on CH3. The BS frame sync signal serves as input trigger to a pulse generator, which generates the 35µs pulses within each slot. The CW interference generator on CH3 is set to -61dBm (T <sub>U</sub> ).
Clause 7.5 (c)	The 50µs requirement is not verified as it is not required by the FCC.
Clause 7.5 (d)	Initiate a communication link from the MS and verify that no connection is setup with a pulse width of 35µs and interference level of -55dBm (T <sub>U</sub> + 6dB).

## Timing diagram of the pulsed interferer

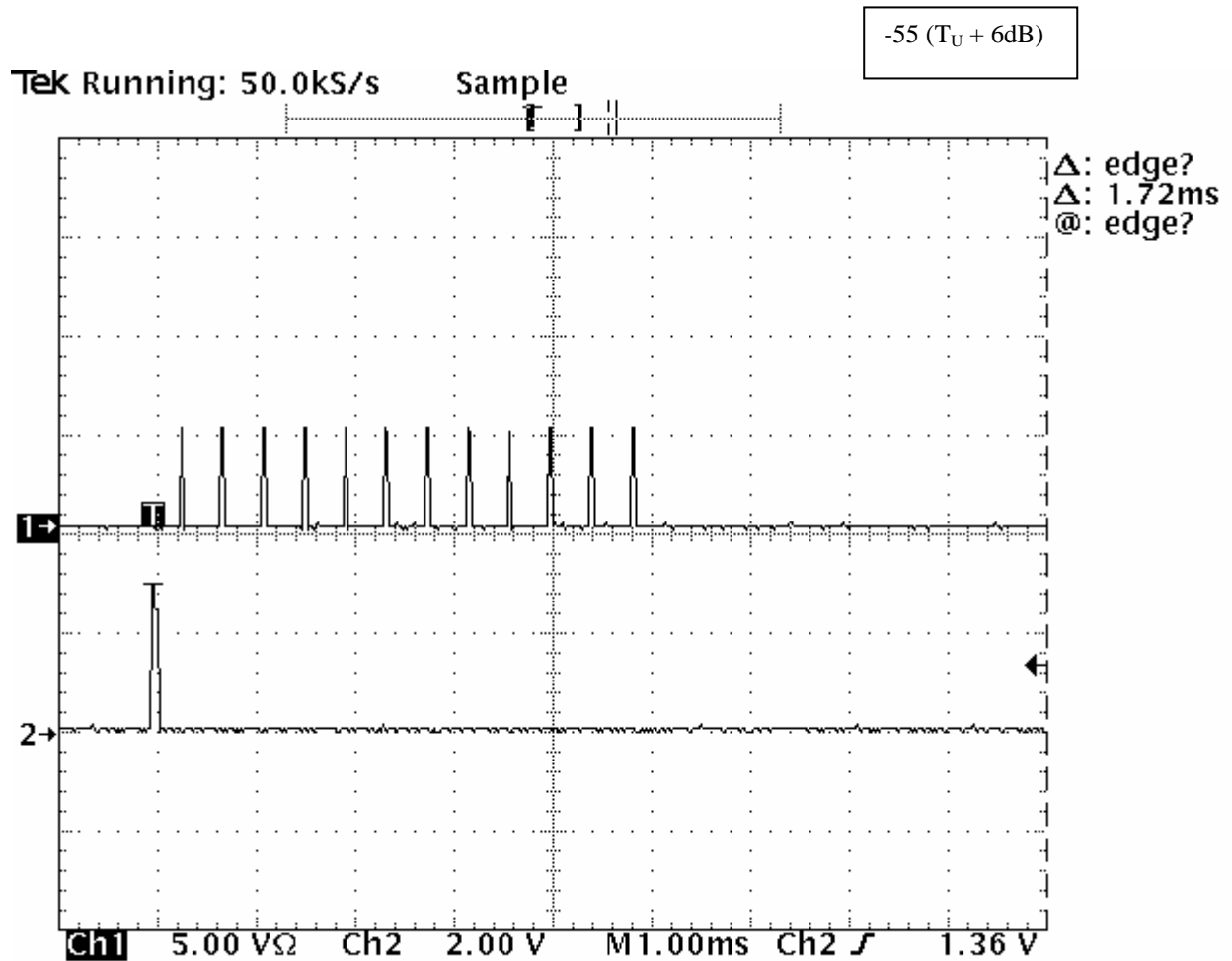

## 4.21.3 Test results

This plot shows the communication link with pulsed interferer at -60.8 dBm

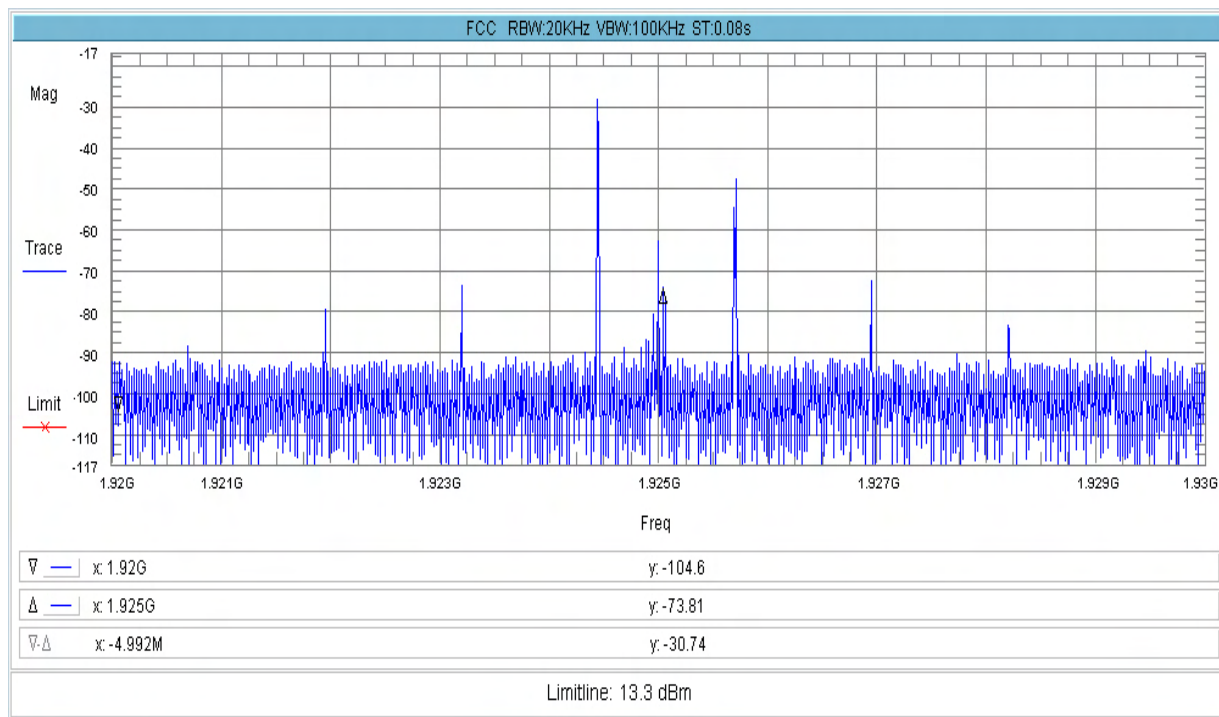

The following test results are obtained:

ANSI C63.17	Description	Result
Clause 7.5 (a)	The EUT is restricted to transmit on CH3 only. MS and BS are synchronized on CH3.	Pass
Clause 7.5 (b)	Synchronized pulsed CW interference is applied on CH3.	Pass
Clause 7.5 (c)	The 50µs requirement is not verified.	n.a.
Clause 7.5 (d)	No communication link can be setup.	Pass

Additional informations:

Interferer at -60.8 dBm > connection ok  
Interferer at -54.8 dBm > no connection possible

**Result: Pass**

## 4.22 Monitoring Antenna

### 4.22.1 Test Criteria

§ 15.323 Specific requirements for isochronous devices operating in the 1920–1930 MHz sub-band.

(c) Isochronous devices must incorporate a mechanism for monitoring the time and spectrum windows that its transmission is intended to occupy. The following criteria must be met:

(8) The monitoring system shall use the same antenna used for transmission, or an antenna that yields equivalent reception at that location.

### 4.22.2 Test Procedure

Testing to ANSI C63.17 draft ballot 3.0 Clause 4, which provides the test methodology for this provision.

### 4.22.3 Attestation

The MS uses a permanently attached antenna.

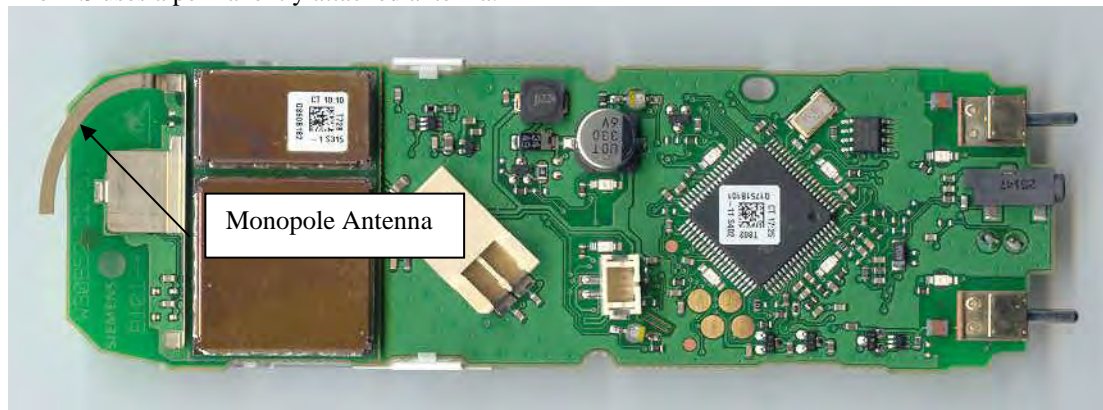

The MS uses a single permanently attached antenna for transmission and monitoring. A TDMA system is realized according to the DECT standard. Channel monitoring and transmission is done through the same antenna.

## 4.23 Monitoring Threshold Relaxation

### 4.23.1 Test Criteria

§ 15.323 Specific requirements for isochronous devices operating in the 1920–1930 MHz sub-band.

(c) Isochronous devices must incorporate a mechanism for monitoring the time and spectrum windows that its transmission is intended to occupy. The following criteria must be met:

(9) Devices that have a power output lower than the maximum permitted under this subpart may increase their monitoring detection threshold by one decibel for each one decibel that the transmitter power is below the maximum permitted.

### 4.23.2 Test Procedure

Testing to ANSI C63.17 draft ballot 3.0 Clause 4, which provides the test methodology for this provision.

### 4.23.3 Test Results

The monitoring threshold of this product is not linked to the output power level.

Description	Value
Permitted Upper Monitoring Threshold	-60.8 dBm + 6dB
Measured Upper Monitoring Threshold	-63.0 dBm
Permitted Peak Transmitter Power	21.8 dBm
Measured Peak Transmitter Power	20.0 dBm

The upper threshold of the BS may be increased with up to 1.8 dB.

**Result: Pass**

## 4.24 Duplex System LBT

### 4.24.1 Test Criteria

§ 15.323 Specific requirements for isochronous devices operating in the 1920–1930 MHz sub-band.

(c) Isochronous devices must incorporate a mechanism for monitoring the time and spectrum windows that its transmission is intended to occupy. The following criteria must be met:

(10) An initiating device may attempt to establish a duplex connection by monitoring both its intended transmit and receive time and spectrum windows.

If both the intended transmit and receive time and spectrum windows meet the access criteria, then the initiating device can initiate a transmission in the intended transmit time and spectrum window. If the power detected by the responding device can be decoded as a duplex connection signal from the initiating device, then the responding device may immediately begin transmitting on the receive time and spectrum window monitored by the initiating device.

### 4.24.2 Procedure

**Testing to ANSI C63.17 draft ballot 3.0 Clause 8.3.2, which provides the test methodology for this provision. The MS is the initiating device and the BS is the companion device.**

For this procedure each slot within a DECT frame raster is setup with a different interference level. Each DECT frame consists out of 24 slots, the first 12 are RX slots and slots 13-24 are TX slots. Only the even slots are active which results in 6 active RX slots and 6 active TX slots. The following test procedure is applied:

ANSI C63.17	Description
Clause 8.3.2 (a)	The BS and the MS are synchronized.
Clause 8.3.2 (b)	Restrict the BS and MS to operate on CH3 only. Verify that a communication link can be setup on CH3. Terminate the connection.
Clause 8.3.2 (c)	Apply pulsed CW interference as shown for Clause 8.3.2 (c).
Clause 8.3.2 (d)	Initiate a communication link from the MS and verify that slot 1 is active for RX and slot 13 for TX. Terminate the connection.
Clause 8.3.2 (e)	Apply pulsed CW interference as shown for Clause 8.3.2 (e).
Clause 8.3.2 (f)	Initiate a communication link from the MS and verify that slot 11 is active for RX and slot 23 for TX. Terminate connection.
Clause 8.3.2 (g)	Apply interference as shown for Clause 8.3.2 (g). No connection should be possible.

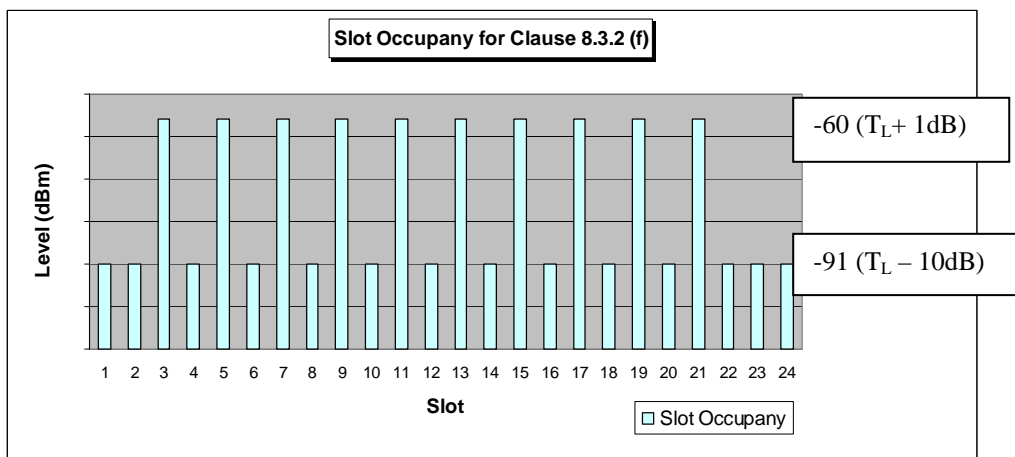
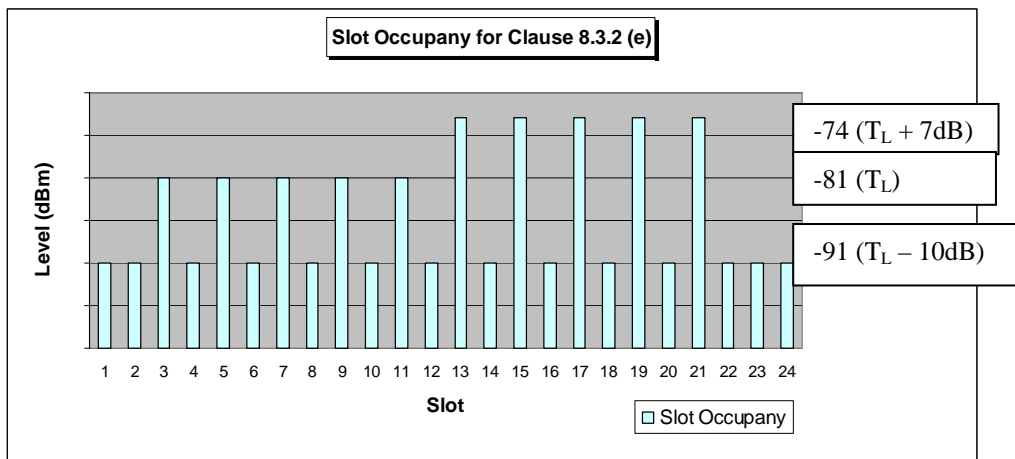
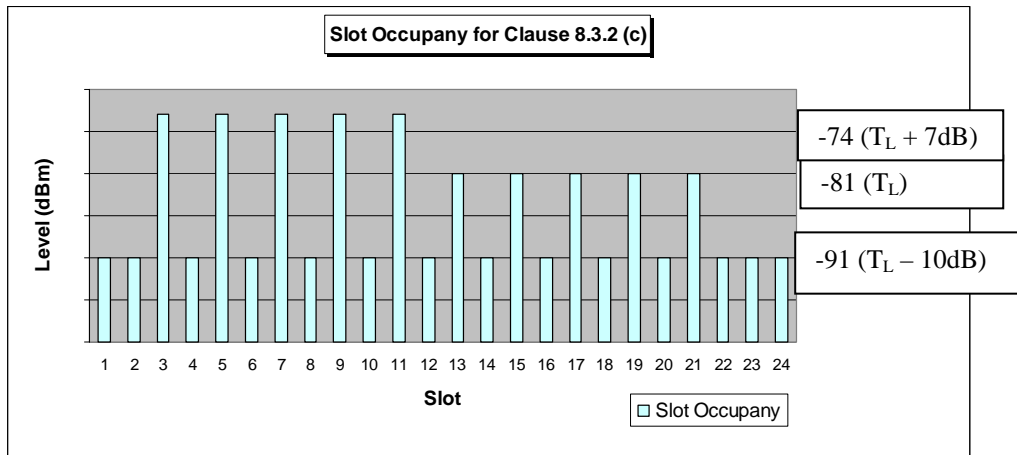

The following test setup is used:

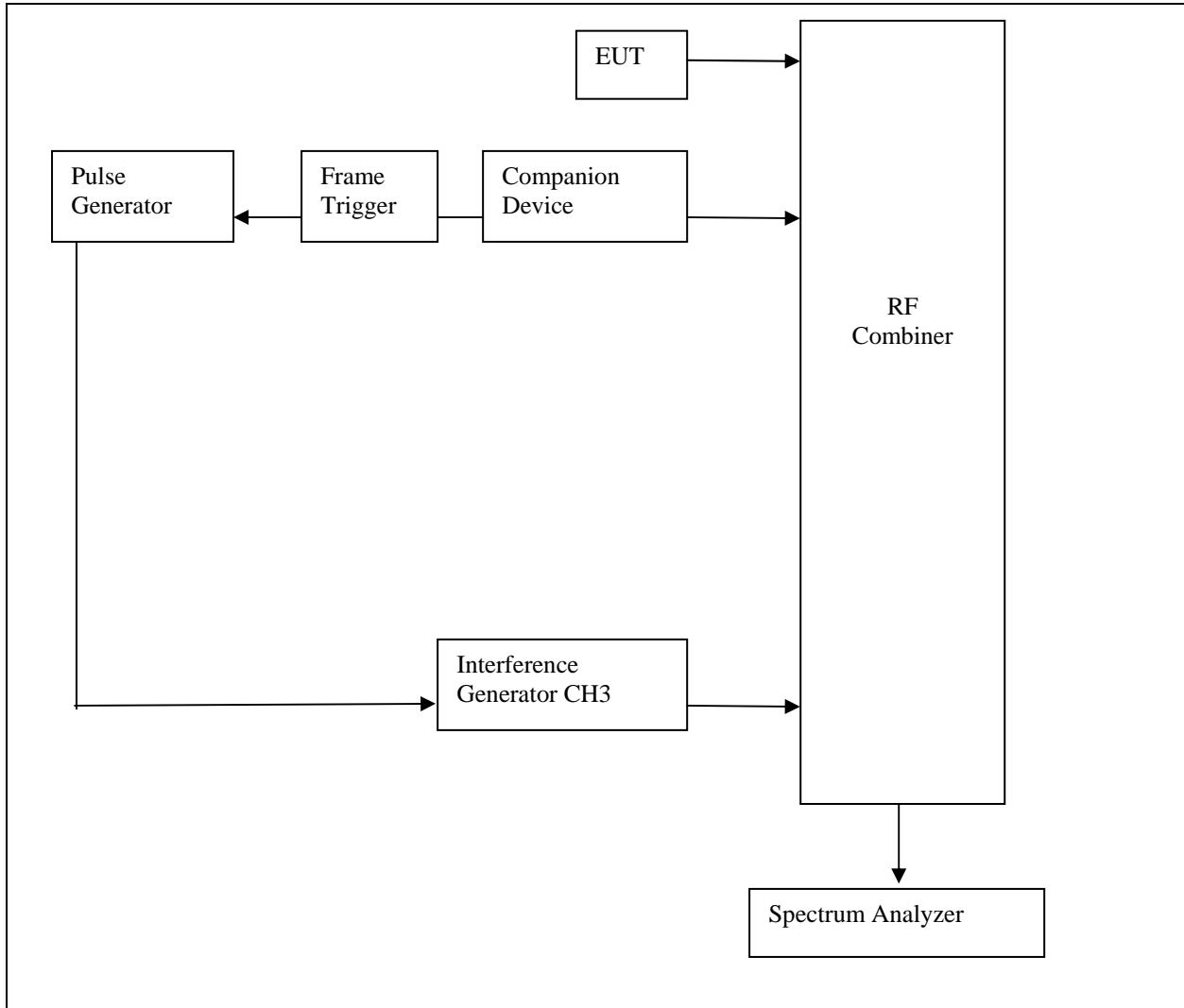

**We used a SMIQ3 from R&S as interferer. This generator is able to produce the desired slot levels itself and is triggered from outside.**



## 4.24.3 Test Results

The following test results are obtained:

ANSI C63.17	Description	Result
Clause 8.3.2 (a)	The patch loss is calibrated.	Pass
Clause 8.3.2 (b)	The frequency channel is restricted to CH3 only. A communication link can be setup on CH3. The connection is terminated.	Pass
Clause 8.3.2 (c)	Apply interference as shown for Clause 8.3.2 (c).	Pass
Clause 8.3.2 (d)	A communication link is setup on slot 1 RX and slot 13 TX. The connection is terminated.	Pass
Clause 8.3.2 (e)	Apply interference as shown for Clause 8.3.2 (e).	Pass
Clause 8.3.2 (f)	A communication link is setup on slot 11 RX and slot 23 TX. The connection is terminated.	Pass
Clause 8.3.2 (g)	Apply interference as shown for Clause 8.3.2 (f). No connection is possible.	Pass

Slot Occupancy for Clause 8.3.2. (c)

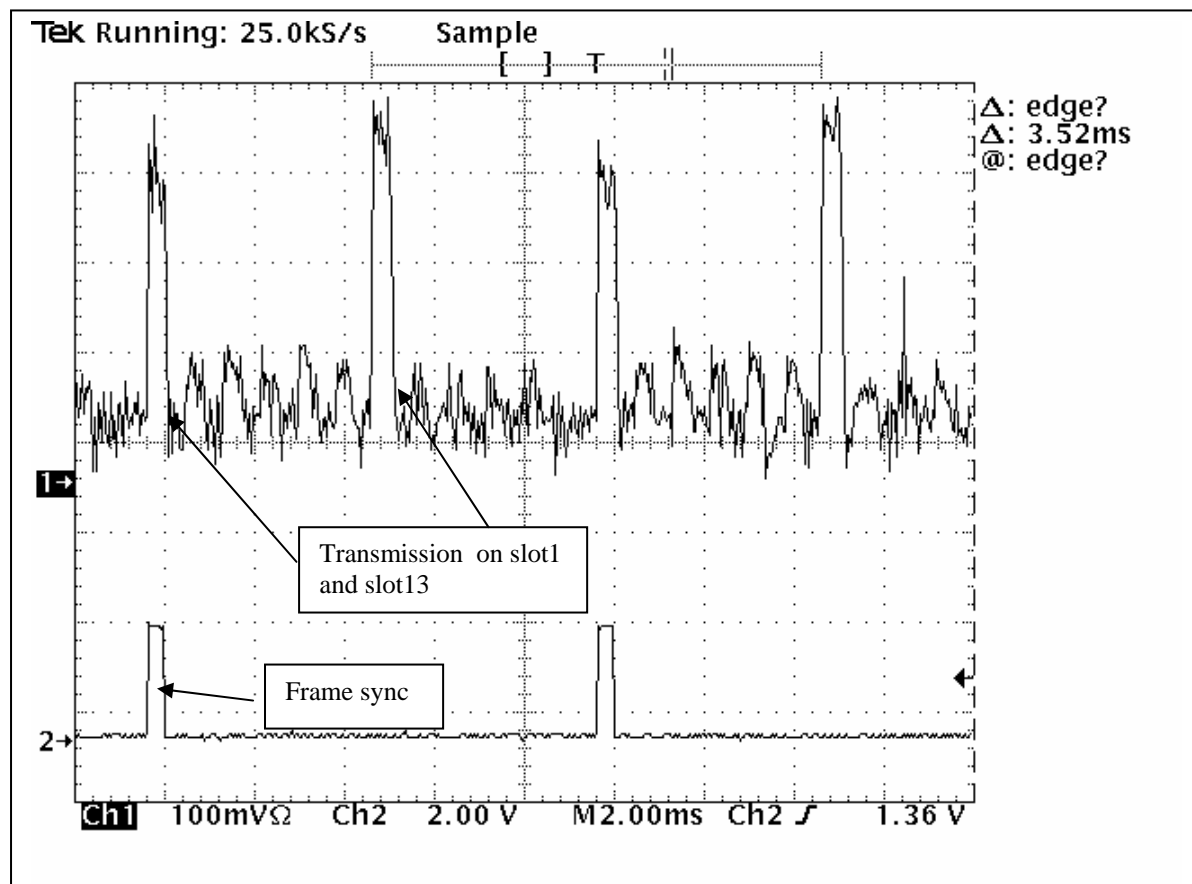

### Slot Occupancy for Clause 8.3.2.(e)

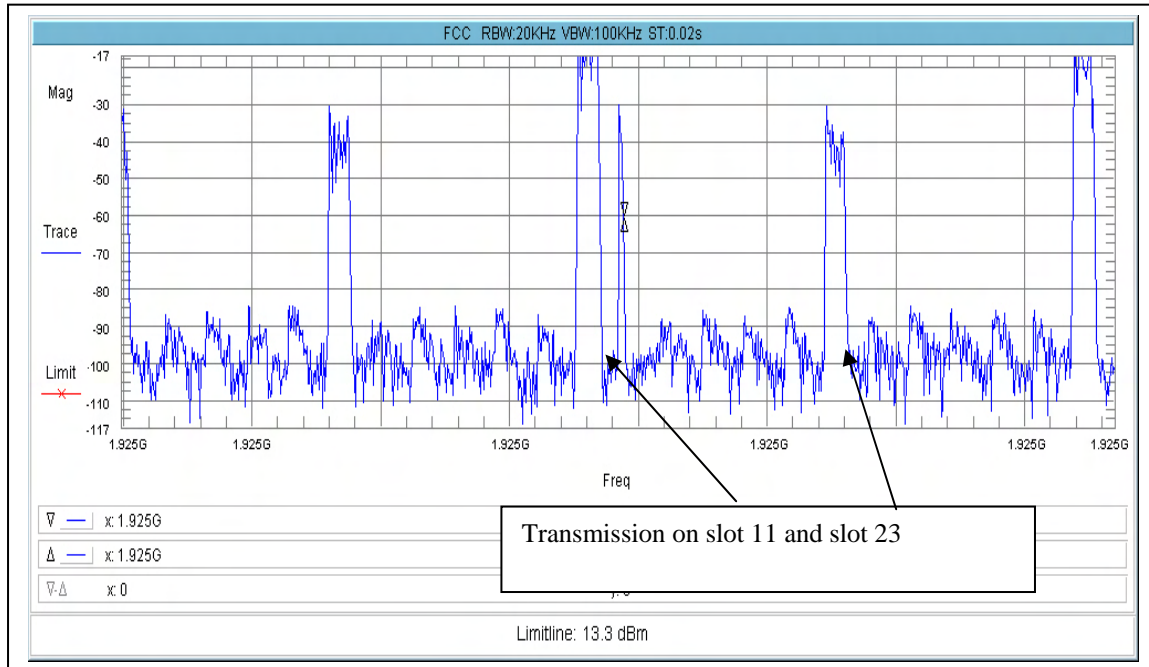

### Slot Occupancy for Clause 8.3.2.(f)

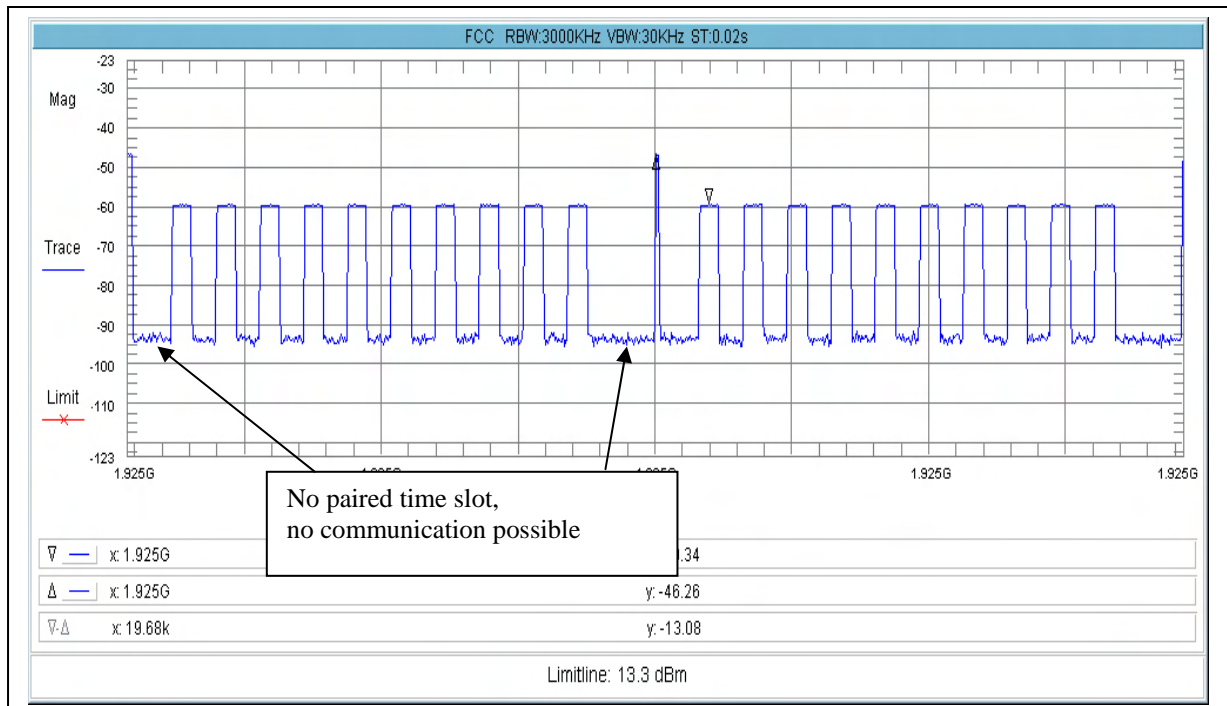

**Result: Pass**

## 4.25 Alternate Monitoring Channel

### 4.25.1 Test Criteria

§ 15.323 Specific requirements for isochronous devices operating in the 1920–1930 MHz sub-band.

(c) Isochronous devices must incorporate a mechanism for monitoring the time and spectrum windows that its transmission is intended to occupy. The following criteria must be met:

(11) An initiating device that is prevented from monitoring during its intended transmit window due to monitoring system blocking from the transmissions of a co-located (within one meter) transmitter of the same system, may monitor the portions of the time and spectrum windows in which they intend to receive over a period of at least 10 milliseconds. The monitored time and spectrum window must total at least 50 percent of the 10 millisecond frame interval and the monitored spectrum must be within the 1.25 MHz frequency channel(s) already occupied by that device or co-located co-operating devices. If the access criteria is met for the intended receive time and spectrum window under the above conditions, then transmission in the intended transmit window by the initiating device may commence.

### 4.25.2 Test Procedure

Testing to ANSI C63.17 draft ballot 3.0 Clause 8.4, which provides the test methodology for this provision. The MS is initiating device and the BS is the companion device

The following test procedure is applied:

<b>ANSI C63.17</b>	<b>Description</b>
Clause 8.4 (a)	The patch Loss is calibrated such that the power level between MS and BS is at -30dBm.
Clause 8.4 (b)	Restrict the BS and MS to operate on frequency channel CH3 only. Verify that a communication link can be setup on CH3. Terminate the connection.
Clause 8.4(c)	Apply interference as shown for Clause 8.4 (c). The interference generator applies a pulsed FSK, a DECT equivalent, signal.
Clause 8.4 (d)	Initiate a communication link from the MS and verify that no connection can be setup. In the available service menu of the MS an indication shows on which slot a link is setup.

The following test setup is used:

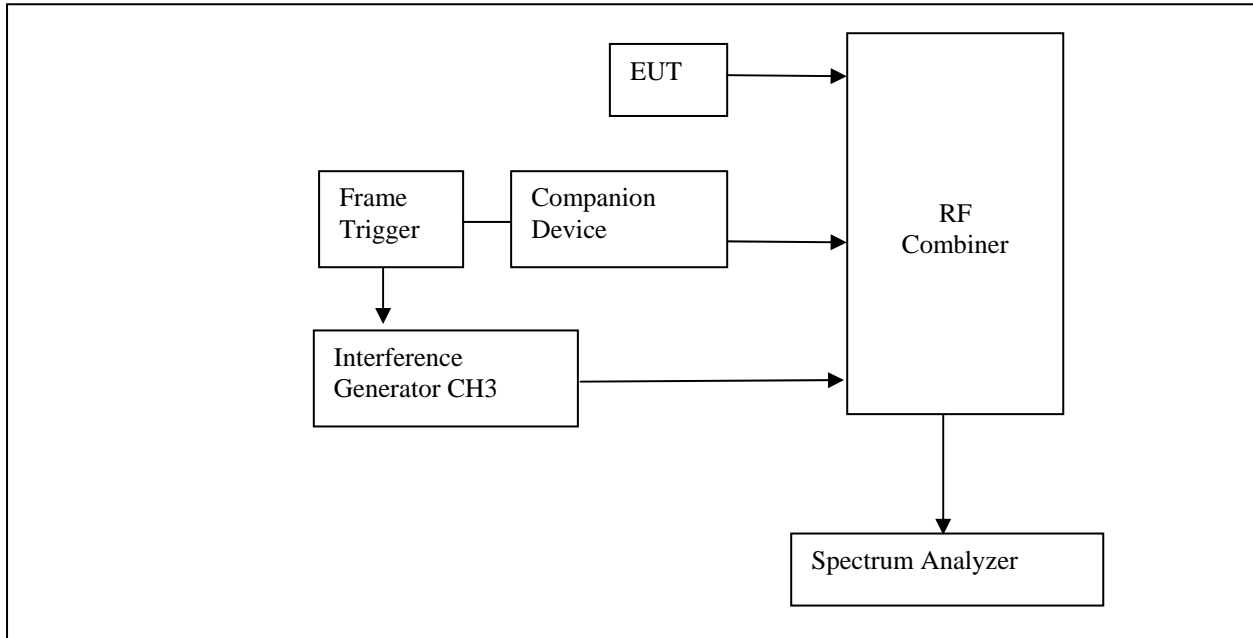

The next plot shows the six occupied time slots.

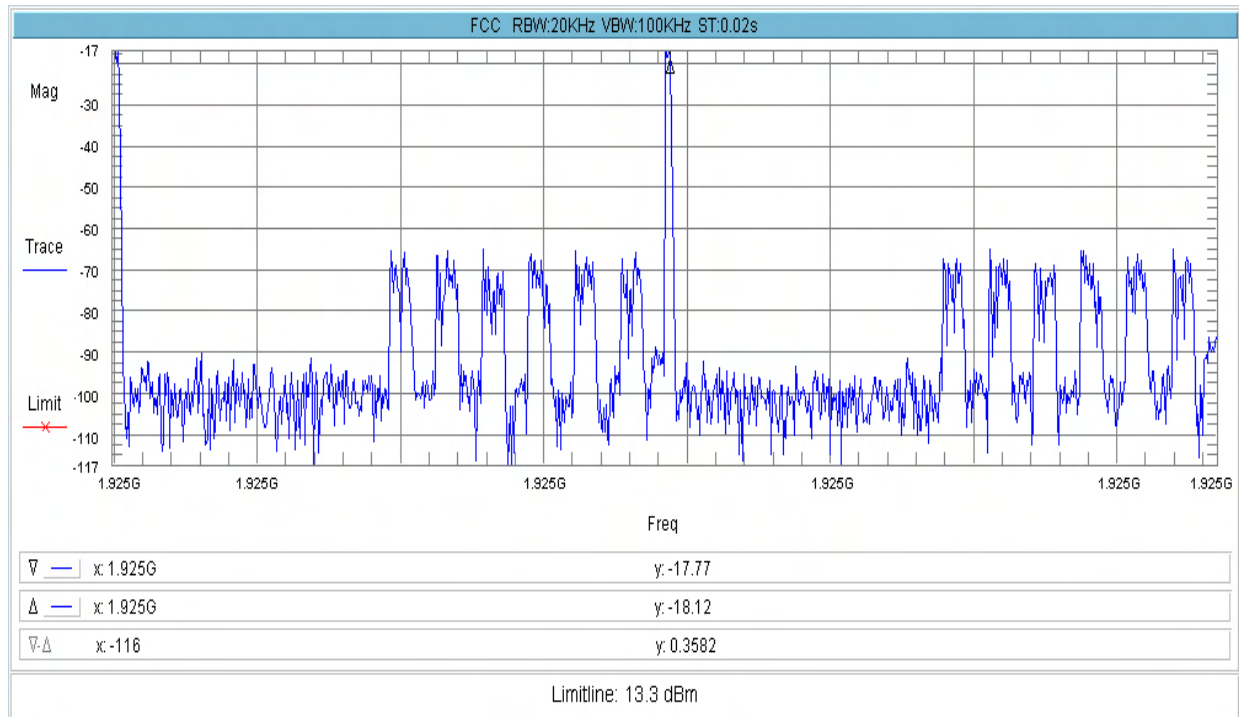

## 4.25.3 Test Result

The following test results are obtained:

<b>ANSI C63.17</b>	<b>Description</b>	<b>Result</b>
Clause 8.4 (a)	The setup is calibrated	Pass
Clause 8.4 (b)	The communication link is restricted to CH3 only. A communication link is setup on CH3. The connection is terminated.	Pass
Clause 8.4(c)	Apply interference as shown for Clause 8.4 (c).	Pass
Clause 8.4 (d)	No connection is setup.	Pass

**Result: Pass**

## 4.26 Fair Access

### 4.26.1 Test Criteria

**§ 15.323 Specific requirements for isochronous devices operating in the 1920–1930 MHz sub-band.**

**(c) Isochronous devices must incorporate a mechanism for monitoring the time and spectrum windows that its transmission is intended to occupy. The following criteria must be met:**

**(12) The provisions of (c)(10) or (c)(11) of this section shall not be used to extend the range of spectrum occupied over space or time for the purpose of denying fair access to spectrum to other devices**

### 4.26.2 Procedure

The manufacturer supplies an attestation.

### 4.26.3 Attestation

**This device does not use any mechanisms as provided by Part 15.323(c)(10) or (c)(11) to deny fair access to spectrum to other devices.**

## 4.27 Frame Period

### 4.27.1 Test Criteria

#### 4.27.1.1 Frame Repetition Stability

§ 15.323 Specific requirements for isochronous devices operating in the 1920–1930 MHz sub-band.

(e) The frame period (a set of consecutive time slots in which the position of each time slot can be identified by reference to a synchronizing source) of an intentional radiator operating in these sub-bands shall be 20 milliseconds or 10 milliseconds/X where X is a positive whole number. Each device that implements time division for the purposes of maintaining a duplex connection on a given frequency carrier shall maintain a frame repetition rate with a frequency stability of at least 50 parts per million (ppm). Each device which further divides access in time in order to support multiple communication links on a given frequency carrier shall maintain a frame repetition rate with a frequency stability of at least 10 ppm.

#### 4.27.1.2 Timing Jitter

§ 15.323 Specific requirements for isochronous devices operating in the 1920–1930 MHz sub-band.

The jitter (time-related, abrupt, spurious variations in the duration of the frame interval) introduced at the two ends of such a communication link shall not exceed 25 microseconds for any two consecutive transmissions. Transmissions shall be continuous in every time and spectrum window during the frame period defined for the device.

## 4.27.2 Test Procedure

### 4.27.2.1 Frame Repetition Stability

Testing to ANSI C63.17 draft ballot 3.0 Clause 6.2.2, which provides the test methodology for this provision.

The EUT is controlled from a personal computer and set into continuous transmission mode. The Spectrum Analyzer is acting as a video detector, by using zero span, and the video output of the spectrum analyzer is monitored by a frequency counter.

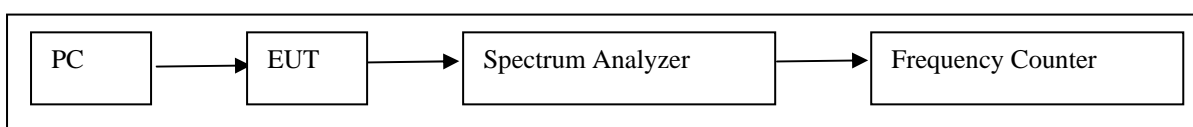

The spectrum analyzer is setup according to ANSI C63.17 Clause 6.2.2:

Centre Frequency	CH3
RBW	3MHz
VBW	3MHz
Trigger	Video
Span	Zero
Detection	Peak Detection
Sweep Rate	2ms
Amplitude Scale	Log
Peak Hold	Off

The GIGASET S45 uses TDMA and a frame period of 10ms.

The frequency counter is gated every 10s and measurements are recorded over 1hour.

The test is performed at 23°C with the EUT set to frequency Channel CH3.

According to ANSI C63.17 Clause 6.2.2, 3 x the standard deviation of the frame-repetition stability should be smaller than 10ppm.



## 4.27.2.2 Timing Jitter

Testing to ANSI C63.17 draft ballot 3.0 Clause 6.2.3, which provides the test methodology for this provision.

The EUT is controlled from a personal computer and set into continuous transmission mode. The Spectrum Analyzer is acting as a video detector, by using zero span, and the video output of the spectrum analyzer is monitored by a frequency counter.

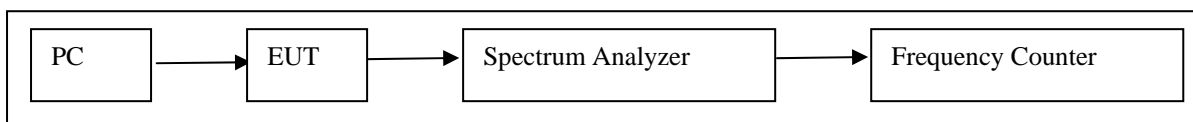

The spectrum analyzer is setup according to ANSI C63.17 Clause 6.2.3:

Centre Frequency	CH3
RBW	3MHz
VBW	3MHz
Trigger	Video
Span	Zero
Detection	Peak Detection
Sweep Rate	2ms
Amplitude Scale	Log
Peak Hold	Off

The frequency counter is gated every 10s and measurements are recorded over 1hour.

The test is performed at 23°C with the EUT set to frequency Channel CH3.

According to ANSI C63.17 Clause 6.2.3, the timing jitter should be smaller than 25µs.

## 4.27.3 Test Results

### 4.27.3.1 Frame Repetition Stability

The mean, standard deviation and 3 x SD as the frame-repetition stability is calculated.

Limit is 10 ppm regarding 100Hz.

Mean Frame Repetition	Standard Deviation	Frame Repetition Stability	Result
99.999 892 1 Hz	0.000 216 76 Hz	6.5 ppm	Pass

**Result: Pass**

### 4.27.3.2 Timing Jitter

The following timing jitter was recorded:

Mean Period	Timing Jitter	Result
10,000 0085 ms	0.0085 $\mu$ s	Pass

**Result: Pass**

## 4.28 Frequency Stability

### 4.28.1 Test Criteria

§ 15.323 Specific requirements for isochronous devices operating in the 1920–1930 MHz sub-band.  
(f) The frequency stability of the carrier frequency of the intentional radiator shall be maintained within +/- 10 ppm over 1 hour or the interval between channel access monitoring, whichever is shorter. The frequency stability shall be maintained over a temperature variation of -20° to +50 °C at normal supply voltage, and over a variation in the primary supply voltage of 85 percent to 115 percent of the rated supply voltage at a temperature of 20 °C. For equipment that is capable only of operating from a battery, the frequency stability tests shall be performed using a new battery without any further requirement to vary supply voltage

### 4.28.2 Test Procedure

Testing to ANSI C63.17 draft ballot 3.0 Clause 6.2.1, which provides the test methodology for this provision.

The EUT is controlled from a personal computer and set into continuous transmission mode.

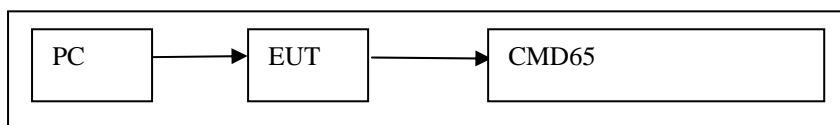

The CMD65 is setup according to ANSI C63.17 Clause 6.2.1:

Centre Frequency	CH3
Mode	Vector Analyzer – DECT Demodulation

The frequency stability of the BS is measured at frequency channel CH3.

A +/-10ppm frequency shift is allowed at 1924.992Hz.

$$\begin{aligned} \text{Frequency Shift} &= 10/1\text{exp}6 * 1925\text{exp}6 \\ &= 19.25\text{KHz} \end{aligned}$$

The following Frequency Offset was measured:

+20°C 85-115% Supply		-20°C Normal Supply		+50°C Normal Supply		Result
KHz	ppm	KHz	ppm	KHz	ppm	
-6.5	-3.4	-5.8	-3.0	-6.0	-3.1	Pass

**Result: Pass**

## **4.29 Radiated emissions**

### **4.29.1 Test Criteria**

**Radiated emissions according to 15.109 and 15.209.  
Measured for TX and RX**

### **4.29.2 Test Procedure**

**The radiated measurements are performed in vertical and horizontal plane in the frequency range from 9 kHz to 25 GHz in semi-anechoic chambers. The EUT is positioned on a non-conductive support with a height of 0.80 m above a conductive ground plane that covers the whole chamber. The receiving antennas are conform with specifications ANSI C63.2-1987 clause 15 and ANSI C63.4-2003 clause 4.1.5. These antennas can be moved over the height range between 1.0 m and 4.0 m in order to search for maximum field strength emitted from EUT. The measurement distances between EUT and receiving antennas are indicated in the test setups for the various frequency ranges. For each measurement, the EUT is rotated in all three axes until the maximum field strength is received. The wanted and unwanted emissions are received by spectrum analysers where the detector modes and resolution bandwidths over various frequency ranges are set according to requirement ANSI C63-4-2003 clause 4.2.**

**Antennas are conform with ANSI C63.2-1996 item 15.**

**9 kHz - 150 MHz: Quasi Peak measurement, 200 Hz Bandwidth, passive loop antenna.**

**150 kHz - 30 MHz: Quasi Peak measurement, 9kHz Bandwidth, passive loop antenna.**

**30 MHz - 200 MHz: Quasi Peak measurement, 120KHz Bandwidth, biconical antenna**

**200MHz - 1GHz: Quasi Peak measurement, 120KHz Bandwidth, log periodic antenna**

**1GHz: Average, RBW 1MHz, VBW 10 MHz, waveguide horn**

## 4.29.3 Test Results

S45 CH1 up to 4 GHz Traffic mode

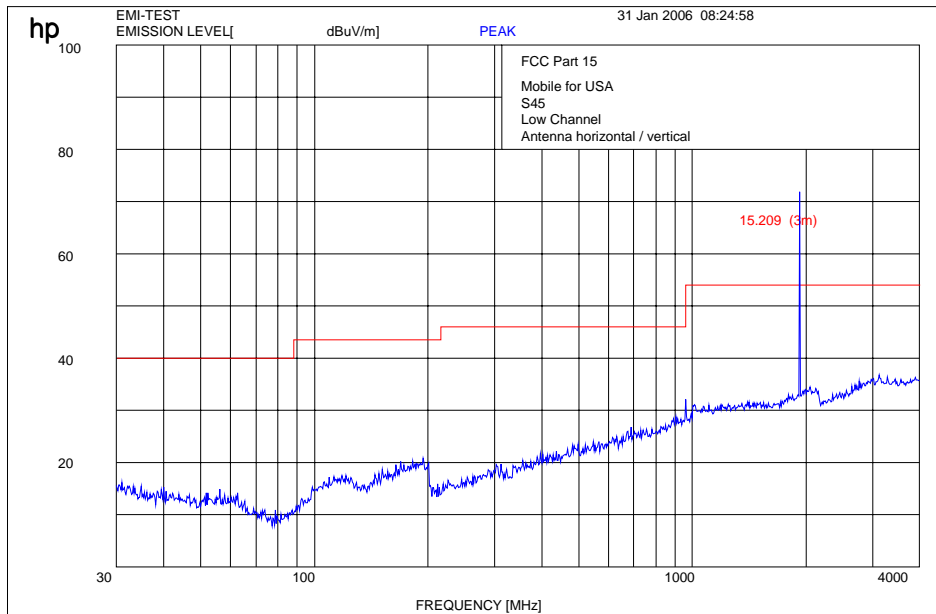

S45 CH1 4 to 12 GHz Traffic mode

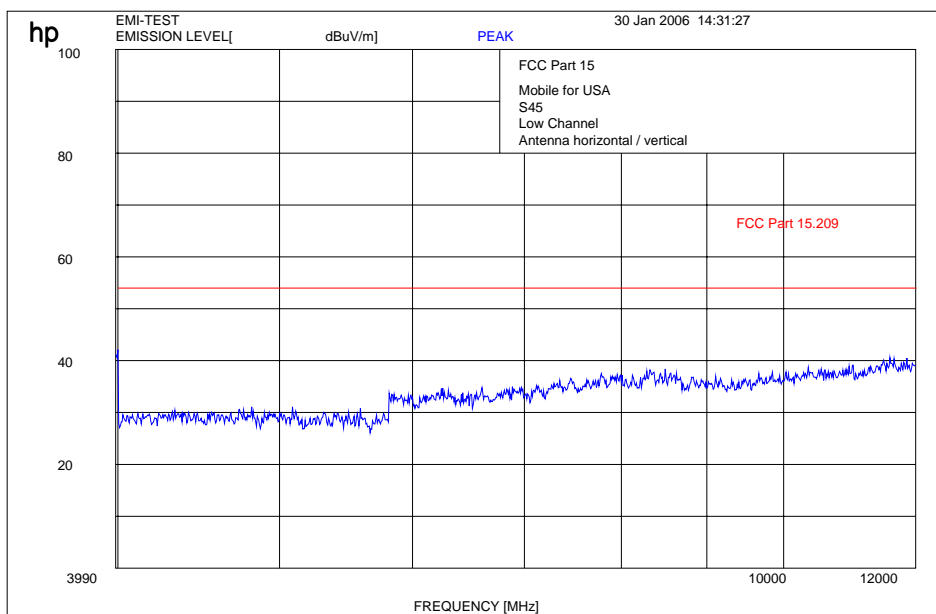

## S45 CH3 up to 4 GHz Traffic mode

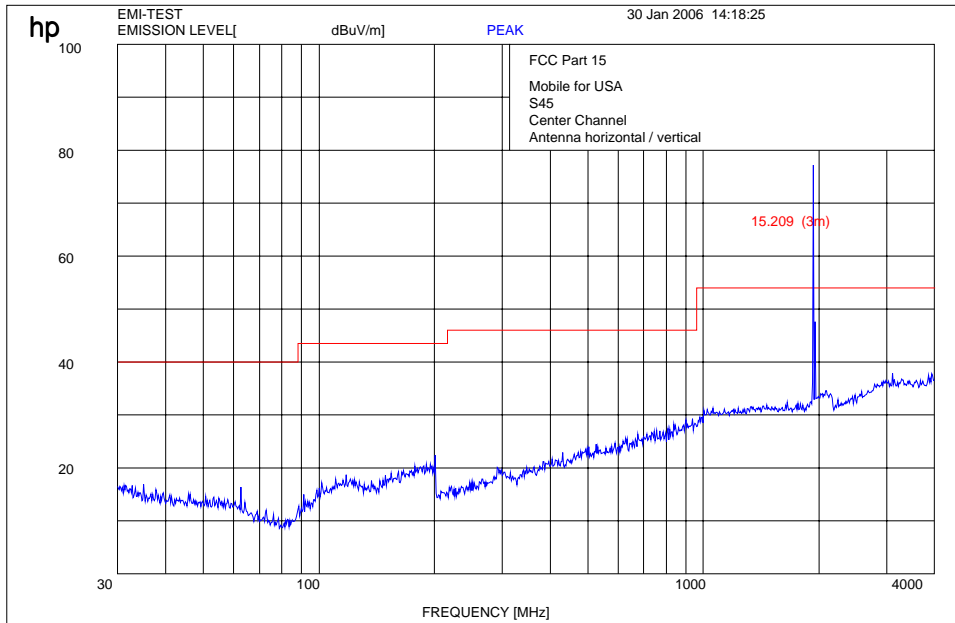

## S45 CH3 4 to 12 GHz Traffic mode

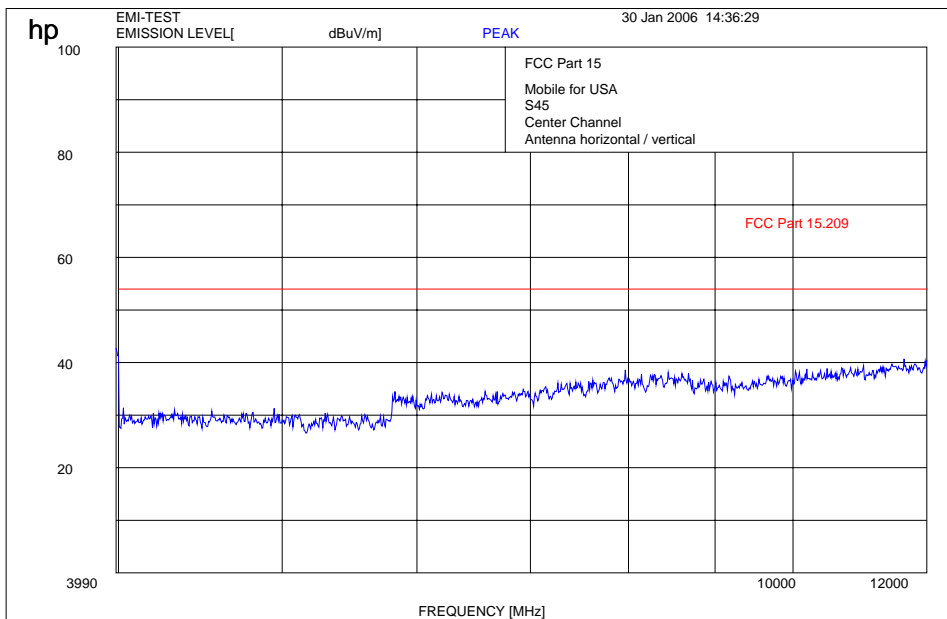

## S45 CH5 up to 4 GHz Traffic mode

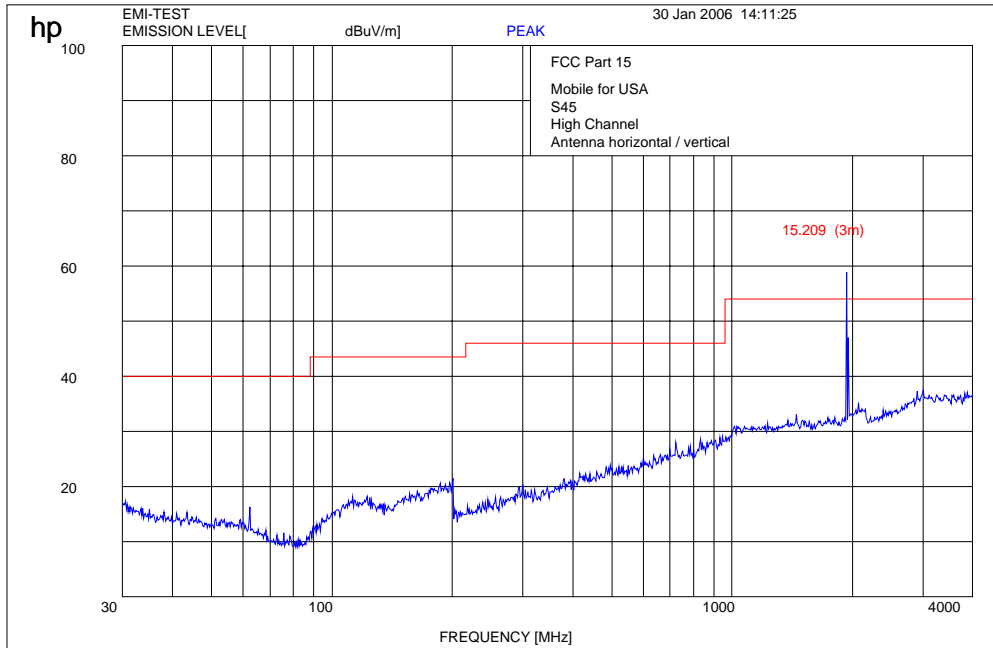

## S45 CH5 4 to 12 GHz Traffic mode

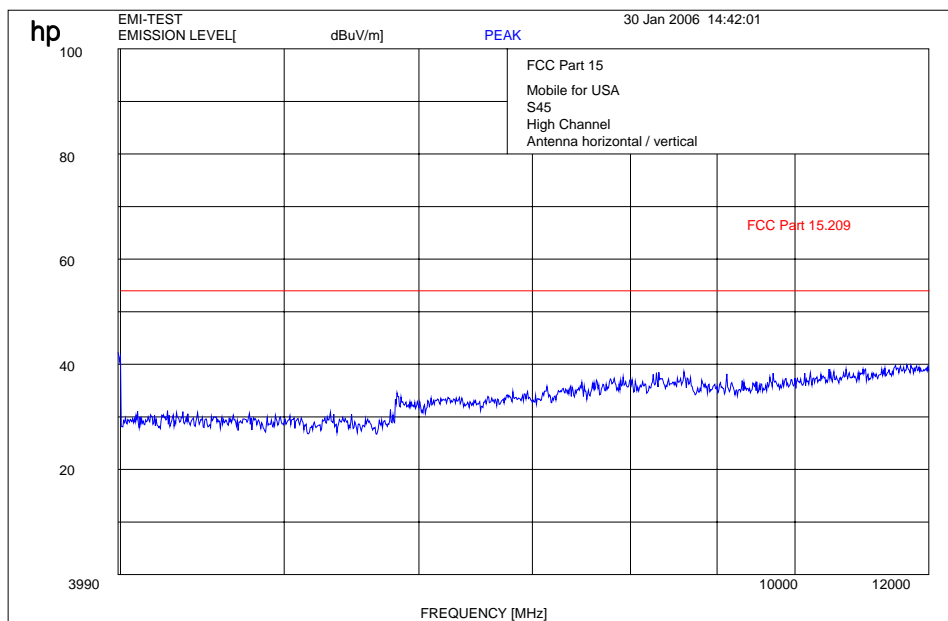

S45 CH3 12 to 25 GHz , valid for all three channels , Traffic and RX only mode



Ref Lvl  
93.4 dBμV

RBW	1 MHz	RF Att	0 dB
VBW	1 MHz	Mixer	-20 dBm
SWT	74 ms	Unit	dBμV

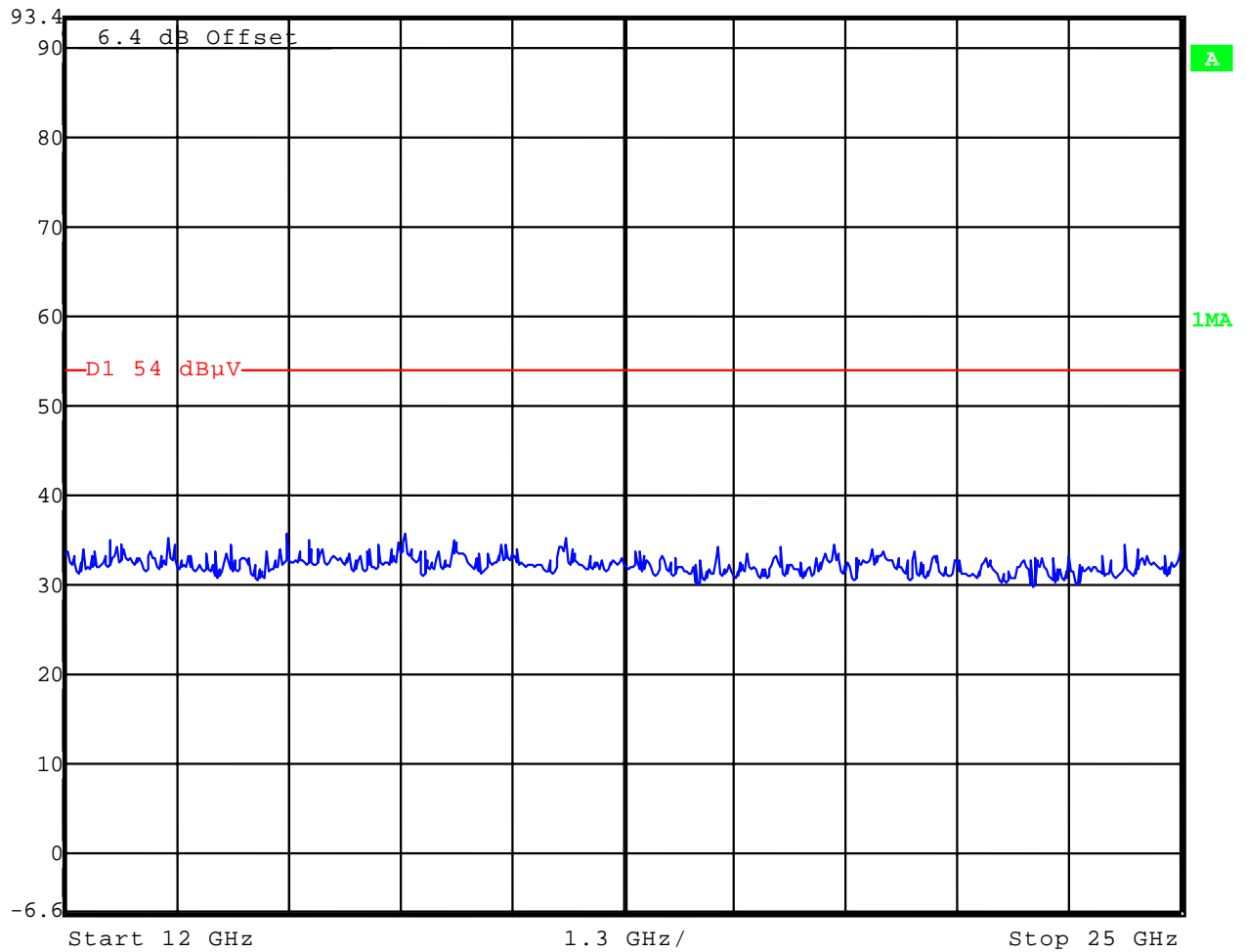



S45 up to 4 GHz RX only

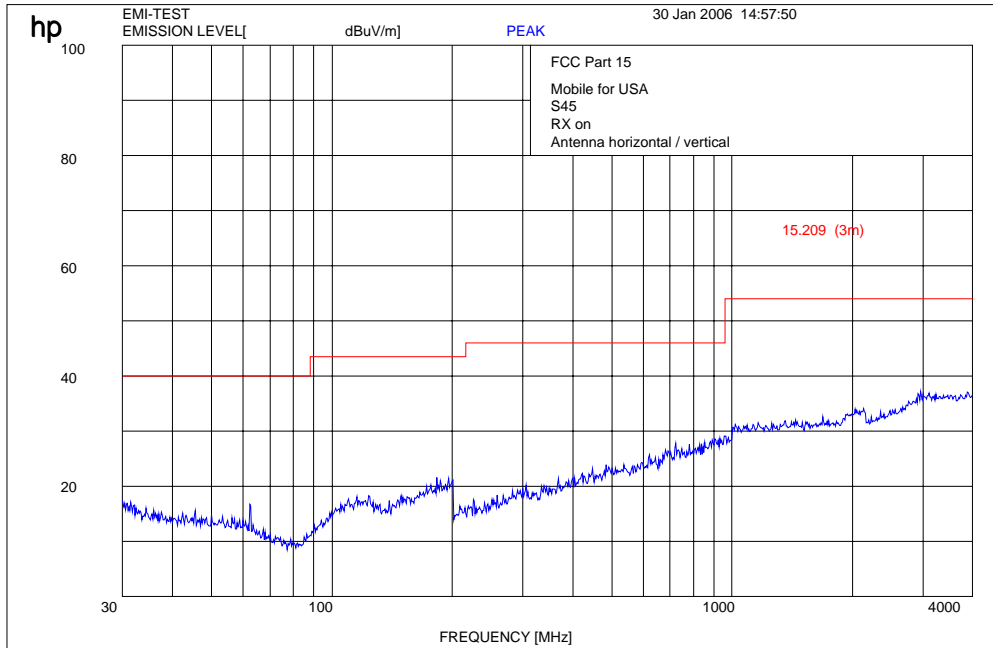

S45 4 to 12 GHz RX only

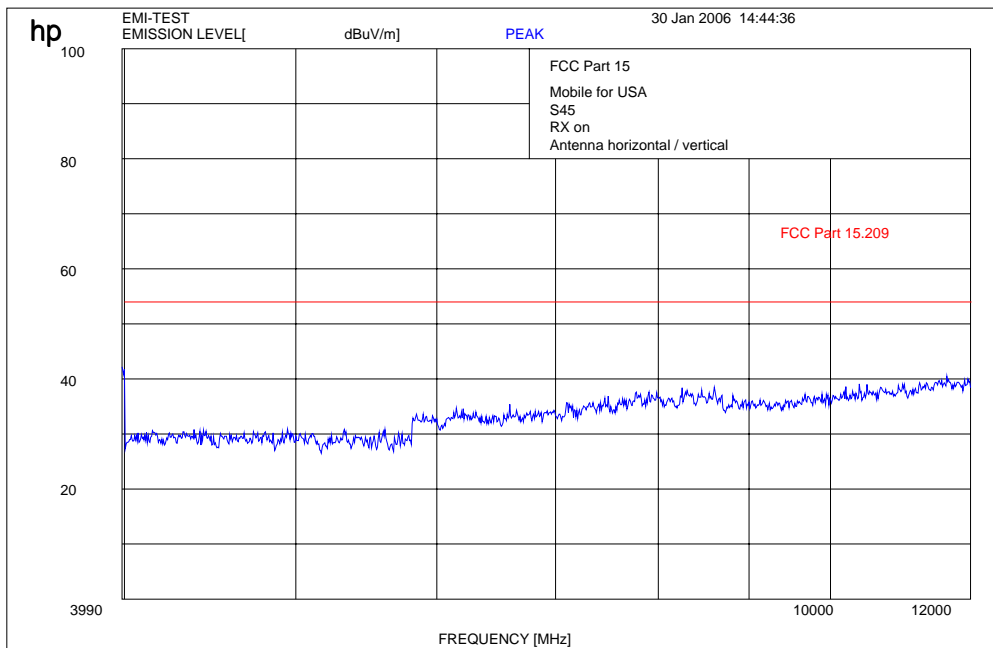

## E45 CH1 up to 4 GHz Traffic mode

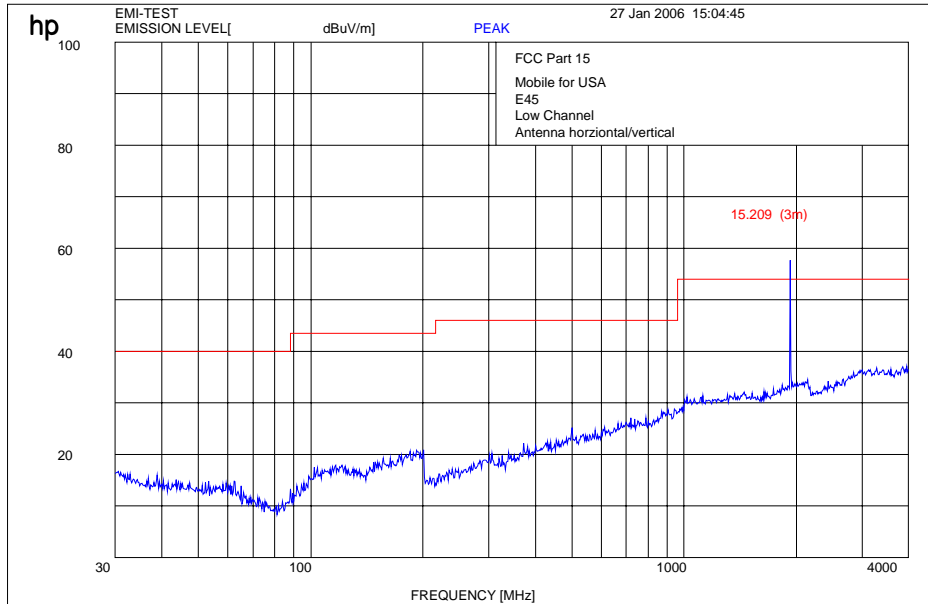

## E45 CH1 4 to 12 GHz Traffic mode

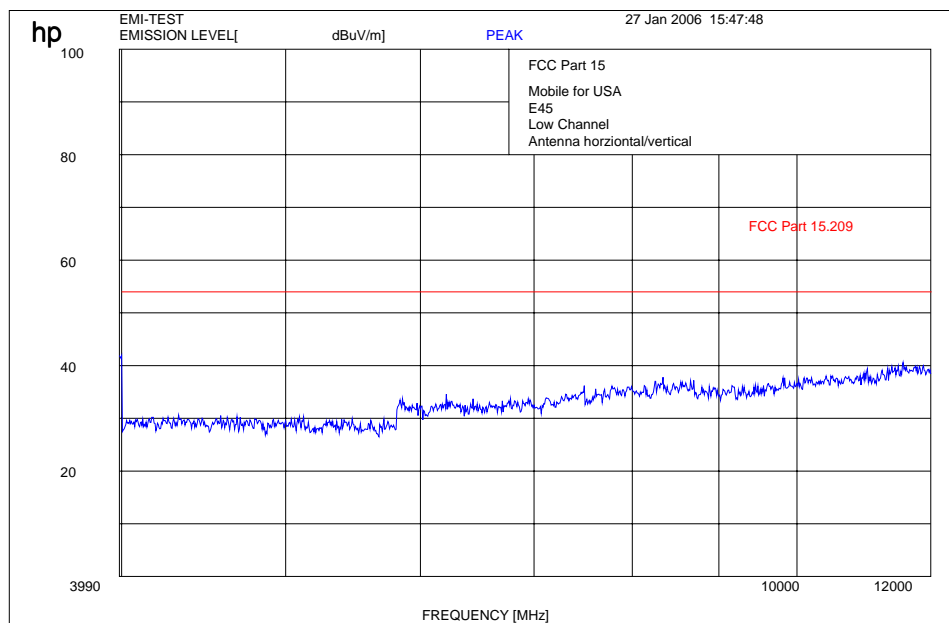

## E45 CH3 up to 4 GHz Traffic mode

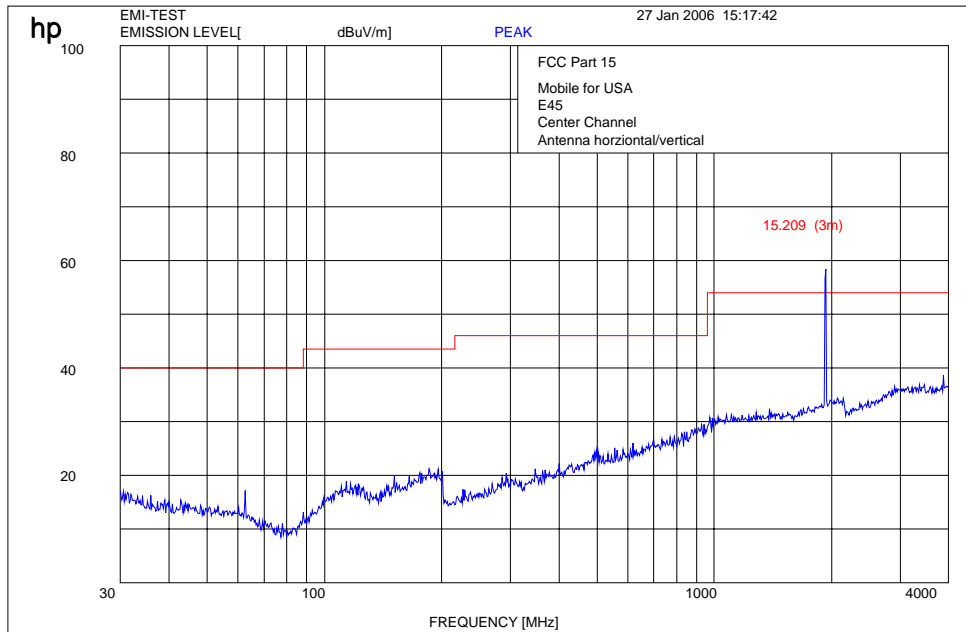

## E45 CH3 4 to 12 GHz Traffic mode

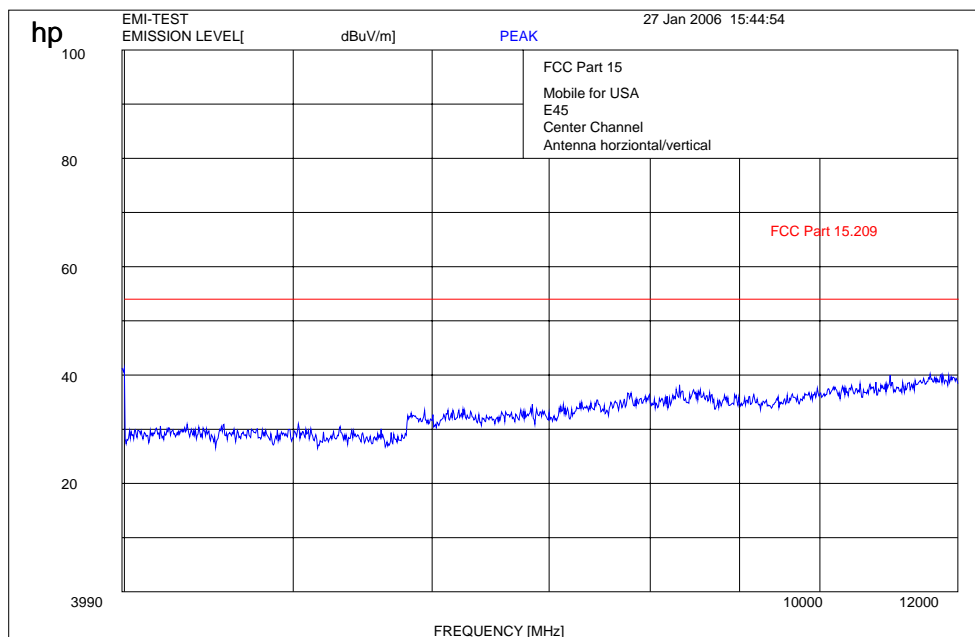

## E45 CH5 up to 4 GHz Traffic mode

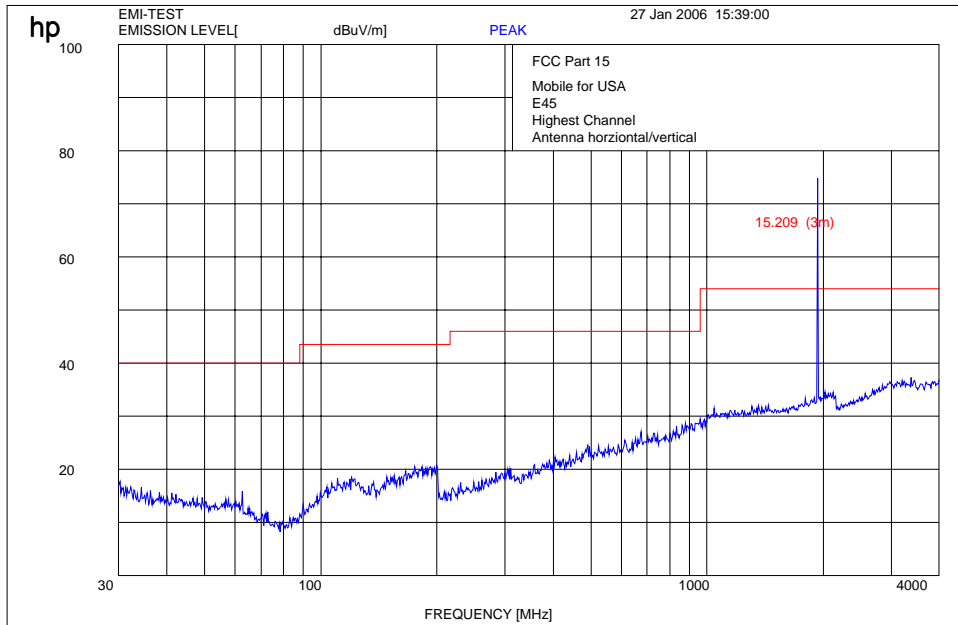

## E45 CH5 4 to 12 GHz Traffic mode

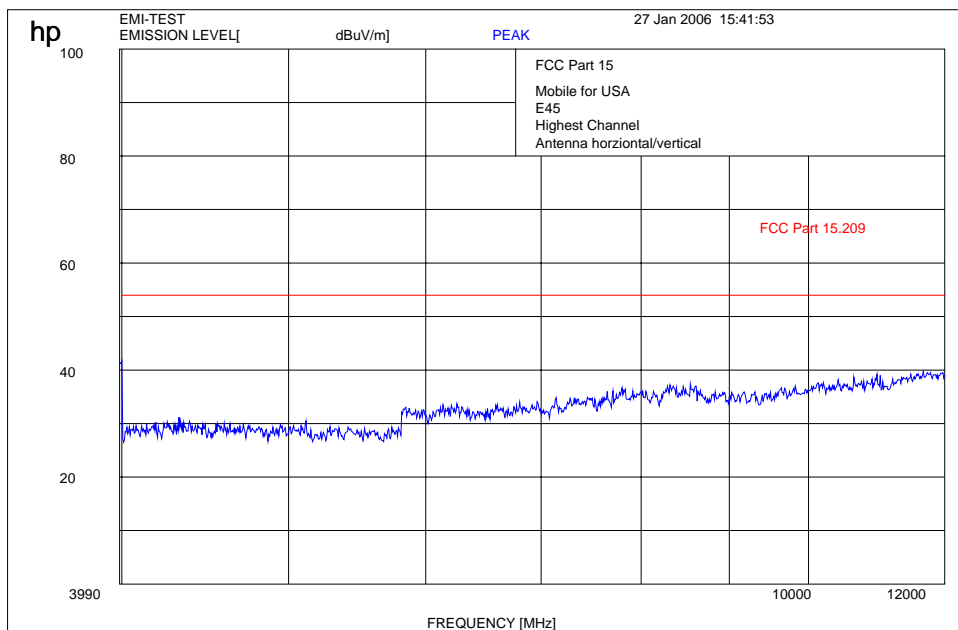

E45 CH3 12 to 25 GHz , valid for all three channels , Traffic and RX only mode



Ref Lvl  
93.4 dBμV

RBW	1 MHz	RF Att	0 dB
VBW	1 MHz	Mixer	-20 dBm
SWT	74 ms	Unit	dBμV

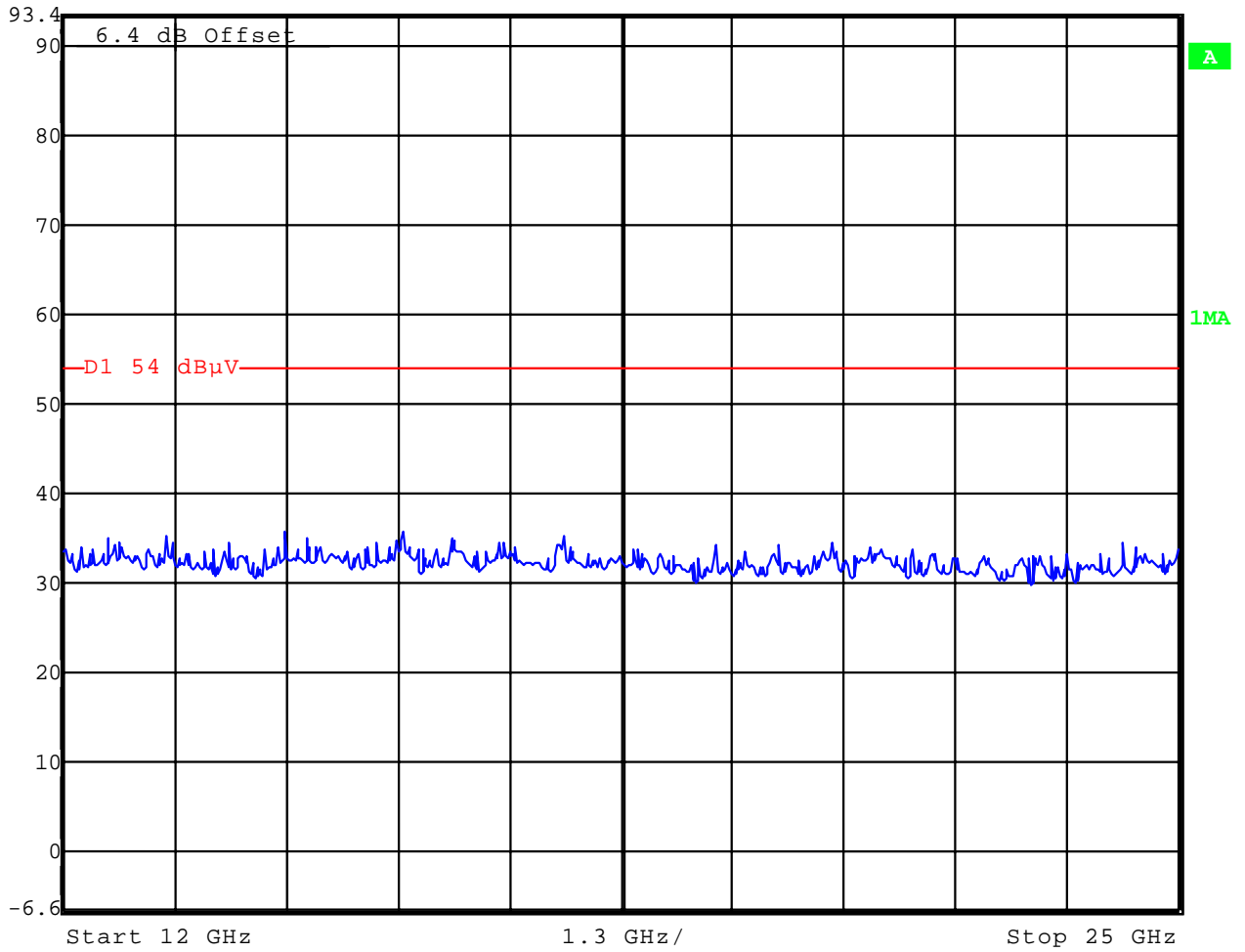

E45 up to 4 GHz RX only

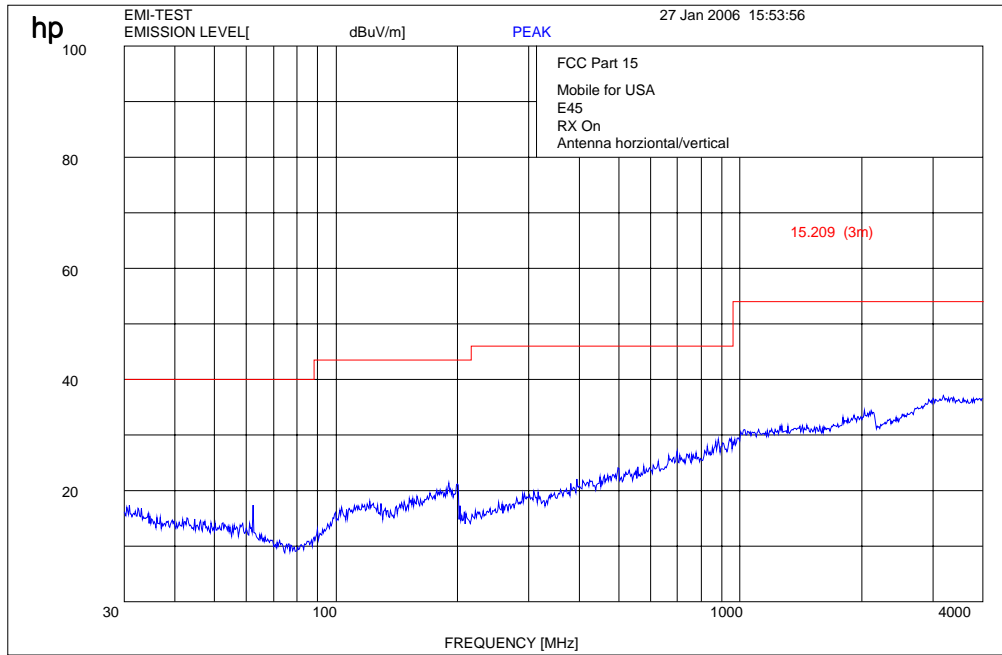

E45 4 to 12 GHz RX only

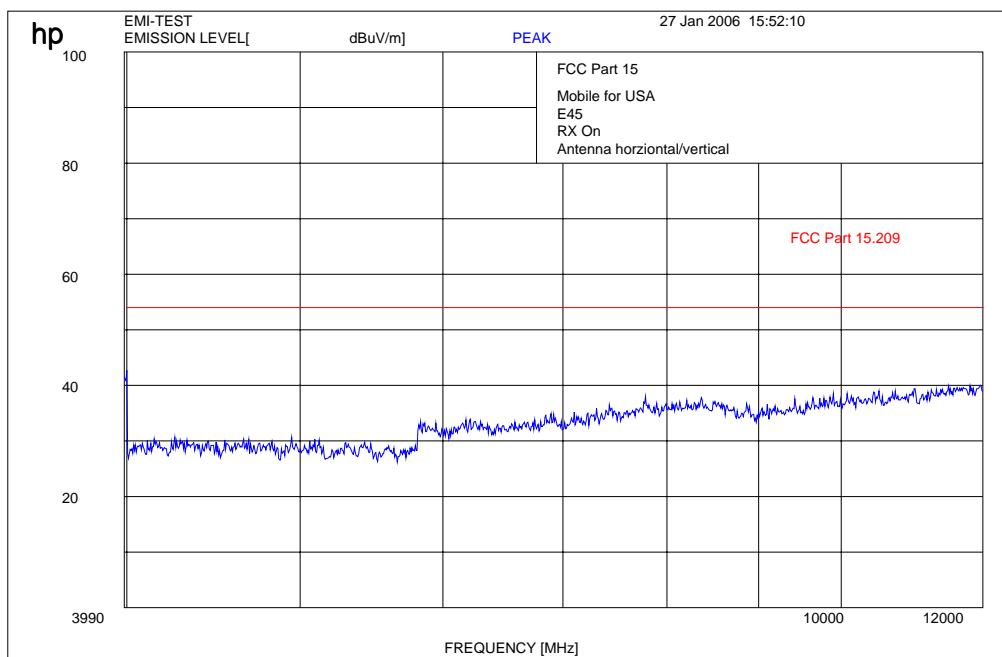

E45 CH3 9 kHz to 30 MHz, valid for all three channels , Traffic and RX only mode

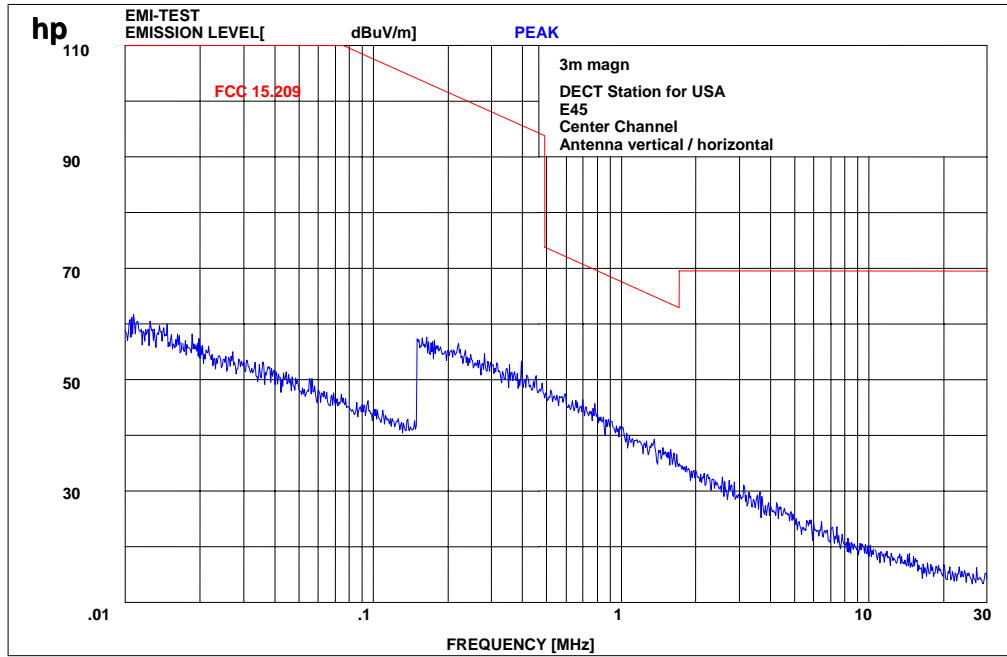

## 4.30 Used Test Equipment

### *Anechoic chamber :*

Device	Manufacturer	Type	S/N Number	Inv. No. Cetecom
Spektrum Analyser	HP	8566B	2747A05306	300001000
Spektrum Analyser Display	HP	85662A	2816A16541	300002297
Quasi-Peak-Adapter	HP	85650A	2811A01131	300000999
Power Supply	HP	6032A	2818A03450	300001040
Power Attenuator	Byrd	8325	1530	300001595
Biconical Antenna	EMCO	3104	3758	300001602
Log. Period. Antenna	EMCO	3146	2130	300001603
Double Ridged Antenna	EMCO	HP 3115P	3088	300001032
Active Loop Antenna	EMCO	6502	2210	300001015
Antenna VDE/FCC		HP11965B		300002298
SRM-Drive	HP	9144A	2823e46556	300001044
Software	HP	EMI		300000983
Busisolator	Kontron			300001056
Absorberhalle	MWB		87400/02	300000996
Salzsäule	Kontron			300001055
Antenna	R&S	HMO20	832211/003	300002243
Indukt.Tast Antenna	R&S	HFH 2 Z4	881468/026	300001464
System-Rack	HP I.V.	85900	*	300000222
Spectrum Analyzer	HP	8566B	2747A05275	300000219
Quasi-Peak-Adapter	HP	85650A	2811A01135	300000216
RF-Preselector	HP	85685A	2837A00779	300000218
Rahmen Antenne	R&S	HFH2-Z2	891847-35	300001169
Leitungsteiler	HP	11850C		300000997
Breitband-Hornantenne EMI	HP	35155P		300002300
PC	HP	Vectra VL		300001688
VHF Meßantenne	Schwarzbeck	VHA 9103		300001778
Spectrum Analyzer Display	HP	85662A	2816A16497	300001690
VHF Meßantenna	Schwarzbeck	VHA 9103		300001780
Biconical Antenna	EMCO	3104 C	9909-4868	300002590

SRD Laboratory: (Bluetooth System)

No	Equipment/Type	Manufact.	Serial Nr.	Inv. No. Cetecom
1	System Controller PSM 12	R&S	835259/007	3000002681
2	Memory Extension PSM-K10	R&S	To 1	3000002681
3	Operating Software PSM-B2	R&S	To 1	3000002681
4	19'' Monitor		22759020-ED	3000002681
5	Mouse		LZE 0095/6639	3000002681
6	Keyboard		G00013834L461	3000002681
7	Spectrum Analyser FSIQ 26	R&S	835540/018	3000002681
8	Tracking Generator FSIQ-B10	R&S	835107/015	3000002681
10	RF-Generator SMIQ03 (B1 Signal)	R&S	835541/056	3000002681
11	Modulation Coder SMIQ-B20	R&S	To 10	3000002681
12	Data Generator SMIQ-B11	R&S	To 10	3000002681
13	RF Rear Connection SMIQ-B19	R&S	To 10	3000002681
14	Fast CPU SM-B50	R&S	To 10	3000002681
15	FM Modulator SM-B5	R&S	835676/033	3000002681
16	RF-Generator SMIQ03 (B2 Signal)	R&S	835541/055	3000002681





## 5 Photographs of Test Set-up

Photo 1: Radiated Emissions S45



E45



Photo 2: Radiated Emissions S45

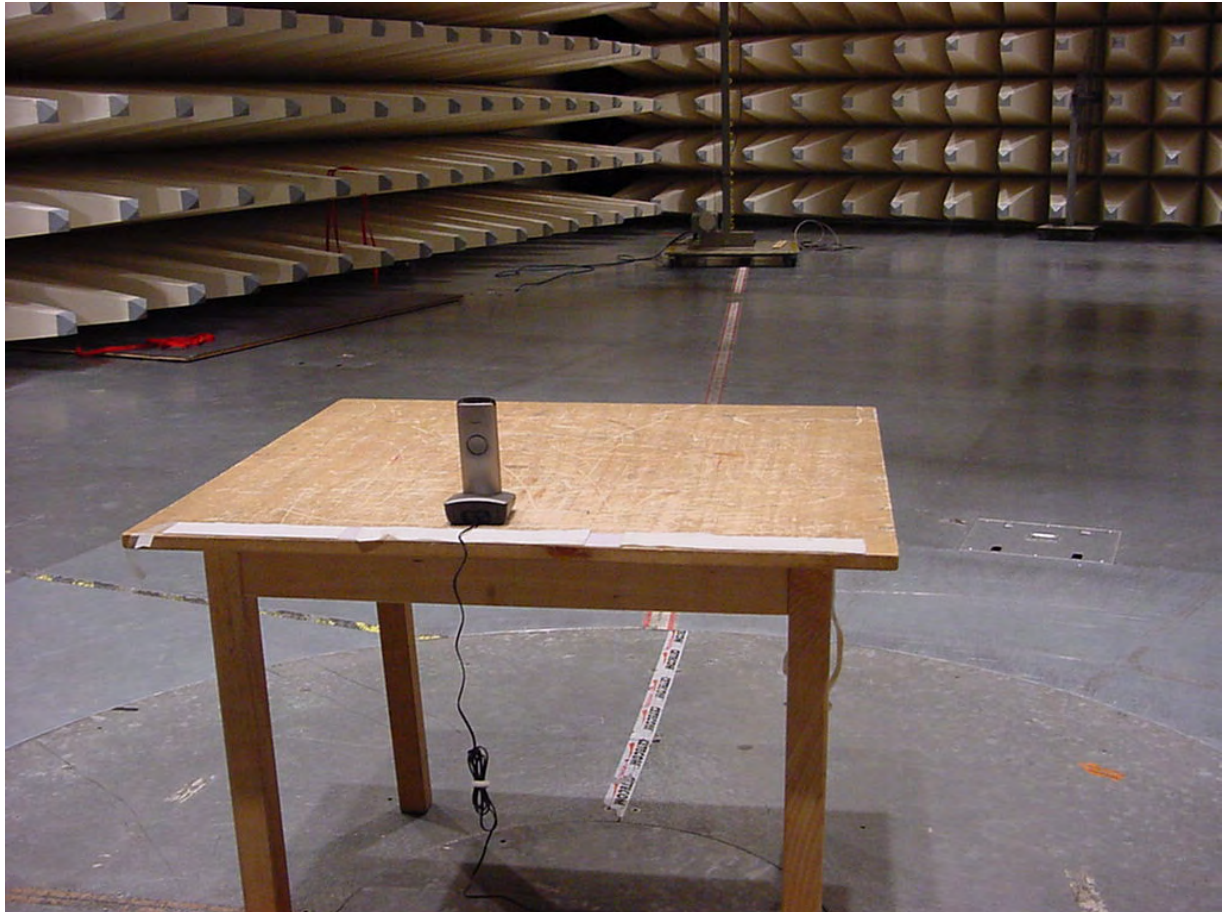

E45



Photo 3: Conducted Emissions S45



E45

