



Test Report

Product Name : Digital Still Camera

Model No. : DSC-S700

FCC ID : TVRDSCS700

Applicant : Hon Hai Precision Industry Co., Ltd. Nei-Hu Branch Office

Address : 1~11 F., No.32, Ji-hu Rd., Nei-hu, Taipei 114, Taiwan,
R.O.C.

Date of Receipt : 2006/12/06

Issued Date : 2006/12/14

Report No. : 06CH036-IT-US-P01V02

The test results relate only to the samples tested.

The test results shown in the test report are traceable to the national/international standard through the calibration of the equipment and evaluated measurement uncertainty herein.

This report must not be used to claim product endorsement by CNLA, NVLAP, NIST or any agency of the Government.

The test report shall not be reproduced except in full without the written approval of QuieTek Corporation.

Test Report Certification

Issued Date : 2006/12/14

Report No. : 06CH036-IT-US-P01V02



Product Name : Digital Still Camera
Applicant : Hon Hai Precision Industry Co., Ltd. Nei-Hu Branch
Office
Address : 1~11 F., No.32, Ji-hu Rd., Nei-hu, Taipei 114, Taiwan,
R.O.C.
Manufacturer : Hon Hai Precision Industry Co., Ltd. Nei-Hu Branch
Office
Model No. : DSC-S700
Rated Voltage : AC 120 V / 60 Hz
EUT Voltage : AC 120 V / 60 Hz
Trade Name : SONY
Applicable Standard : FCC CFR Title 47 Part 15 Subpart B: 2005 Class B,
CISPR 22: 2005
Test Result : Complied
Performed Location : Hsinchu EMC Laboratory
N0. 75-2, 3rd Lin, Wangye Keng, Yonghxing Tsuen,
Qionglin Shiang, Hsinchu County 307, Taiwan, R.O.C.
TEL:+886-3-592-8858 / FAX:+886-3-592-8859

Documented By : Carol Tsai
(Carol Tsai)

Reviewed By : Winson Wen
(Winson Wu)

Approved By : Arthur Liu
(Arthur Liu)

Laboratory Information

We , **Quietek Corporation**, are an independent EMC and safety consultancy that was established the whole facility in our laboratories. The test facility has been accredited by the following accreditation Bodies in compliance with ISO 17025, EN 45001 and Guide 25:

Taiwan R.O.C.	:	BSMI, DGT, CNLA
Germany	:	TUV Rheinland
Norway	:	Nemko, DNV
USA	:	FCC, NVLAP
Japan	:	VCCI

The related certificate for our laboratories about the test site and management system can be downloaded from Quietek Corporation's Web Site : <http://tw.quietek.com/modules/myalbum/>

The address and introduction of Quietek Corporation's laboratories can be founded in our Web site : <http://www.quietek.com/>

If you have any comments, Please don't hesitate to contact us. Our contact information is as below:

HsinChu Testing Laboratory :

No.75-2, 3rd Lin, Wangye Keng, Yonghxing Tsuen, Qionglin Shiang, Hsinchu County 307, Taiwan, R.O.C.

TEL:+886-3-592-8858 / FAX:+886-3-592-8859

E-Mail : service@quietek.com



LinKou Testing Laboratory :

No. 5, Ruei-Shu Valley, Ruei-Ping Tsuen, Lin-Kou Shiang, Taipei, Taiwan, R.O.C.

TEL : 886-2-8601-3788 / FAX : 886-2-8601-3789

E-Mail : service@quietek.com



TABLE OF CONTENTS

Description	Page
1. General Information	5
1.1. EUT Description	5
1.2. Mode of Operation	6
1.3. Tested System Details.....	7
1.4. Configuration of Tested System	8
1.5. EUT Exercise Software	10
2. Technical Test.....	11
2.1. Summary of Test Result	11
2.2. List of Test Equipment.....	11
2.3. Measurement Uncertainty	12
2.4. Test Environment	12
3. Conducted Emission	13
3.1. Test Specification	13
3.2. Test Setup	13
3.3. Limit.....	13
3.4. Test Procedure	14
3.5. Test Result	15
3.6. Test Photograph	19
4. Radiated Emission	20
4.1. Test Specification	20
4.2. Test Setup	20
4.3. Limit.....	21
4.4. Test Procedure	22
4.5. Test Result	23
4.6. Test Photograph	39
5. Attachment.....	47
EUT Photograph.....	47

1. General Information

1.1. EUT Description

Product Name	Digital Still Camera
Trade Name	SONY
Model No.	DSC-S700
Max Resolution	7.2 Mega Pixels

Component	
USB Cable	Shielded, 1.5m, one ferrite core bonded.
AV Cable	Shielded, 1.5m, one ferrite core bonded.
Battery Cable	Shielded, 0.15m
Power Adapter	SONY, AC-LS5 Cable Out: Non-Shielded, 1.8m Power Cord: Non-Shielded, 1.8m

Note:

This EUT is a Digital Still Camera.

1.2. Mode of Operation

Quietek has verified the construction and function in typical operation. All the test modes were carried out with the EUT in normal operation, which was shown in this test report and defined as:

Pre-Test Mode		
Mode 1: Slide Show		
Mode 2: REC		
Mode 3: USB LCD on		
Mode 4: Preview		
Final Test Mode		
Emission	Conducted Emission	Mode 3: USB LCD on
	Radiated Emission	Mode 1: Slide Show Mode 2: REC Mode 3: USB LCD on Mode 4: Preview

1.3. Tested System Details

The types for all equipments, plus descriptions of all cables used in the tested system (including inserted cards) are:

Test Mode		Mode 1: Slide Show Mode 2: REC Mode 4: Preview				
Product		Manufacturer	Model No.	Serial No.	FCC ID	Power Cord
1	Monitor	SONY	PVM-14M2U	2013141	DoC	Non-Shielded, 1.8m

Test Mode		Mode 3: USB LCD on				
Product		Manufacturer	Model No.	Serial No.	FCC ID	Power Cord
1	Notebook PC	DELL	PP10L	3Y220	E2K24BNHM	Non-Shielded, 1.8m
2	Monitor	CHI MEI	A170E1-09	3UC120955S A1250	DoC	Non-Shielded, 1.8m
3	Digital 8 (D8)	SONY	DCR-TRV110	P35209	DoC	--
4	Microphone & Earphone	Ronald	MOE060	N/A	DoC	--
5	USB 2.0 Flash Memory	Ridata	PEN000-DP0 65-37	N/A	DoC	--
6	Modem	ACEEX	DM-1414	0102027546	DoC	Non-Shielded, 1.6m
7	TV	THOMSON	15LCDMO3B SN	15LCDMO3B SN FRD100085	DoC	Non-Shielded, 1.8m
8	Printer	HP	C2642A	MY75L1D2X N	DoC	Non-Shielded, 0.7m

1.4. Configuration of Tested System

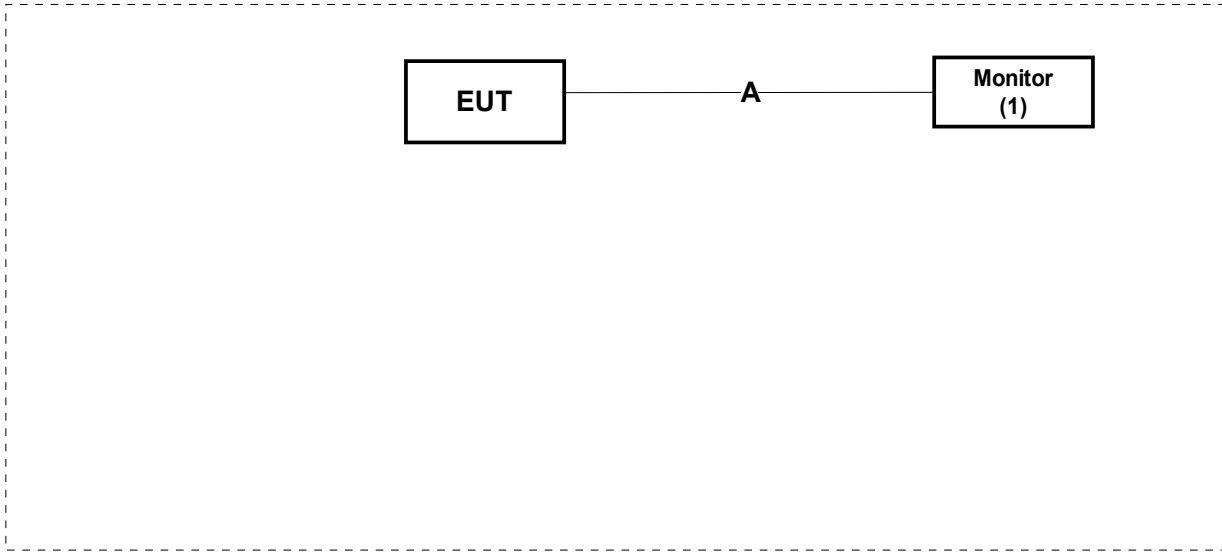
Test Mode	Mode 1: Slide Show Mode 2: REC Mode 4: Preview		
Connection Diagram			
 <pre> graph LR EUT[EUT] --- A[A] --- Monitor["Monitor (1)"] </pre>			
Signal Cable Type		Signal cable Description	Interface
A	AV Cable	Non-Shielded, 1.5m	AV Port

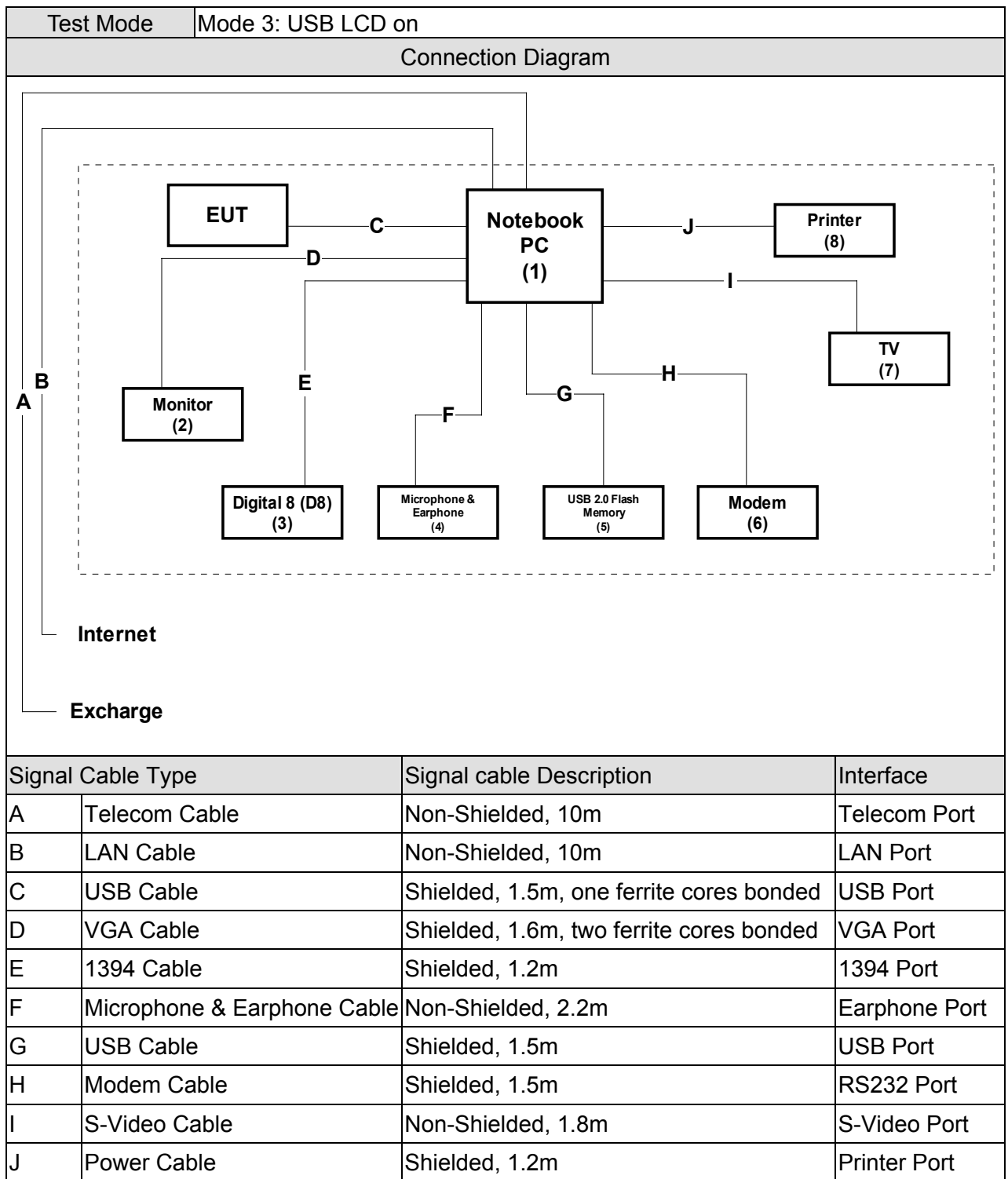

2. Technical Test

2.1. Summary of Test Result

- No deviations from the test standards
 Deviations from the test standards as below description:

Emission			
Performed Item	Normative References	Test Performed	Deviation
Conducted Emission	FCC CFR Title 47 Part 15 Subpart B: 2005 Class B, CISPR 22: 2005, ANSI C63.4: 2003	Yes	No
Radiated Emission	FCC CFR Title 47 Part 15 Subpart B: 2005 Class B, CISPR 22: 2005, ANSI C63.4: 2003	Yes	No

2.2. List of Test Equipment

Conducted Emission / SR2

Instrument	Manufacturer	Type No.	Serial No	Cal. Date
4-Wire ISN	R & S	ENY 41	837032/001	2006/02/25
Artificial Mains Network	R & S	ENV4200	848411/010	2006/02/18
Double 2-Wire ISN	R & S	ENY 22	835354/008	2006/02/25
LISN	R & S	ESH3-Z5	825562/002	2006/02/18
Pulse Limiter	R & S	ZSH3Z2	357.8810.52	2006/02/12
Test Receiver	R & S	ESCS 30	825442/018	2006/09/16

Radiated Emission / Site2

Instrument	Manufacturer	Type No.	Serial No	Cal. Date
Bilog Antenna	Schaffner Chase	CBL6112B	2708	2006/09/03
Horn Antenna	Schwarzbeck	BBHA 9120D	BBHA9120D312	2006/07/29
Pre-Amplifier	QuieTek	QTK-AMP	AMP1	N/A
Pre-Amplifier	HP	8449B	3008A01123	2006/02/15
Spectrum Analyzer	Advantest	R3261C	81720471	2006/02/17
Spectrum Analyzer	R & S	FSP40	100005	2006/08/25
Test Receiver	R & S	ESCS 30	836858/023	2006/02/17

2.3. Measurement Uncertainty

Conducted Emission

The measurement uncertainty is evaluated as ± 2.26 dB.

Radiated Emission

The measurement uncertainty is evaluated as ± 3.19 dB.

2.4. Test Environment

Performed Item	Items	Required	Actual
Conducted Emission	Temperature (°C)	15-35	25
	Humidity (%RH)	25-75	50
	Barometric pressure (mbar)	860-1060	950-1000
Radiated Emission	Temperature (°C)	15-35	25
	Humidity (%RH)	25-75	65
	Barometric pressure (mbar)	860-1060	950-1000

3. Conducted Emission

3.1. Test Specification

According to Standard: FCC Part 15 Subpart B, ANSI C63.4

3.2. Test Setup

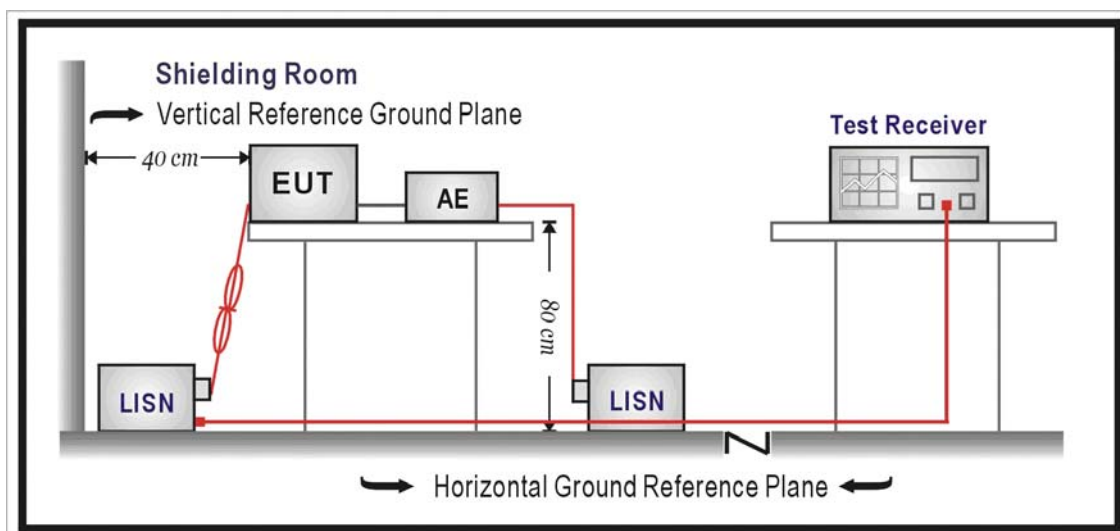

3.3. Limit

Limits		
Frequency (MHz)	QP (dBuV)	AV (dBuV)
0.15 - 0.50	66 - 56	56 - 46
0.50-5.0	56	46
5.0 - 30	60	50

Remarks: In the above table, the tighter limit applies at the band edges.

3.4. Test Procedure

The EUT and simulators are connected to the main power through a line impedance stabilization network (L.I.S.N.). This provides a 50 ohm /50uH coupling impedance for the measuring equipment. The peripheral devices are also connected to the main power through a LISN that provides a 50ohm/50uH coupling impedance with 50ohm termination.

(Please refers to the block diagram of the test setup and photographs.)

Both sides of A.C. line are checked for maximum conducted interference. In order to find the maximum emission, the relative positions of equipment and all of the interface cables must be changed on conducted measurement.

Conducted emissions were invested over the frequency range from 0.15MHz to 30MHz using a receiver bandwidth of 9kHz.

3.5. Test Result

Site : Quietek Shielding Room2	Time : 2006/12/11 - 10:24
Limit : CISPR_B_00M_QP	Margin : 0
EUT : Digital Still Camera	Probe : SR3_LISN(16A) - Line1
Power : AC 120V/60Hz	Note : Mode 3: USB LCD on

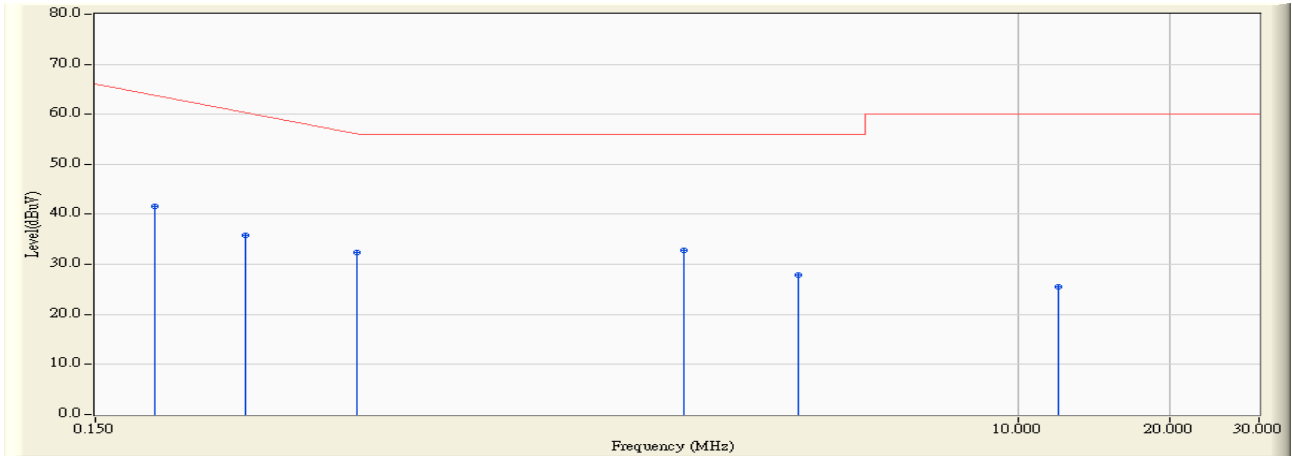

		Frequency (MHz)	Correct Factor (dB)	Reading Level (dBuV)	Measure Level (dBuV)	Margin (dB)	Limit (dBuV)	Detector Type
1	*	0.197	0.253	41.350	41.603	-23.054	64.657	QUASIPeAK
2		0.298	0.277	35.470	35.747	-26.024	61.771	QUASIPeAK
3		0.494	0.510	31.960	32.470	-23.701	56.171	QUASIPeAK
4		2.181	0.800	31.940	32.740	-23.260	56.000	QUASIPeAK
5		3.670	0.830	27.030	27.860	-28.140	56.000	QUASIPeAK
6		12.002	1.540	24.040	25.580	-34.420	60.000	QUASIPeAK

Note:

1. All Reading Levels are Quasi-Peak and average value.
2. " * ", means this data is the worst emission level.
3. Measurement Level = Reading Level + Correct Factor.

Site : Quietek Shielding Room2	Time : 2006/12/11 - 10:24
Limit : CISPR_B_00M_AV	Margin : 0
EUT : Digital Still Camera	Probe : SR3_LISN(16A) - Line1
Power : AC 120V/60Hz	Note : Mode 3: USB LCD on

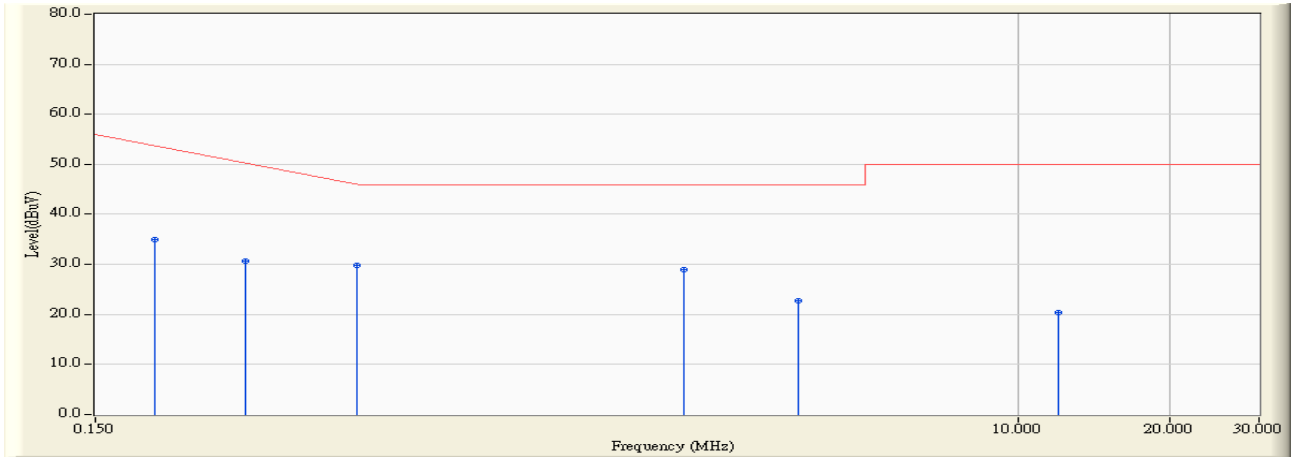

		Frequency (MHz)	Correct Factor (dB)	Reading Level (dBuV)	Measure Level (dBuV)	Margin (dB)	Limit (dBuV)	Detector Type
1		0.197	0.253	34.790	35.043	-19.614	54.657	AVERAGE
2		0.298	0.277	30.390	30.667	-21.104	51.771	AVERAGE
3	*	0.494	0.510	29.220	29.730	-16.441	46.171	AVERAGE
4		2.181	0.800	28.090	28.890	-17.110	46.000	AVERAGE
5		3.670	0.830	21.840	22.670	-23.330	46.000	AVERAGE
6		12.002	1.540	18.760	20.300	-29.700	50.000	AVERAGE

Note:

1. All Reading Levels are Quasi-Peak and average value.
2. " * ", means this data is the worst emission level.
3. Measurement Level = Reading Level + Correct Factor.

Site : Quietek Shielding Room2	Time : 2006/12/11 - 10:27
Limit : CISPR_B_00M_QP	Margin : 0
EUT : Digital Still Camera	Probe : SR3_LISN(16A) - Line2
Power : AC 120V/60Hz	Note : Mode 3: USB LCD on

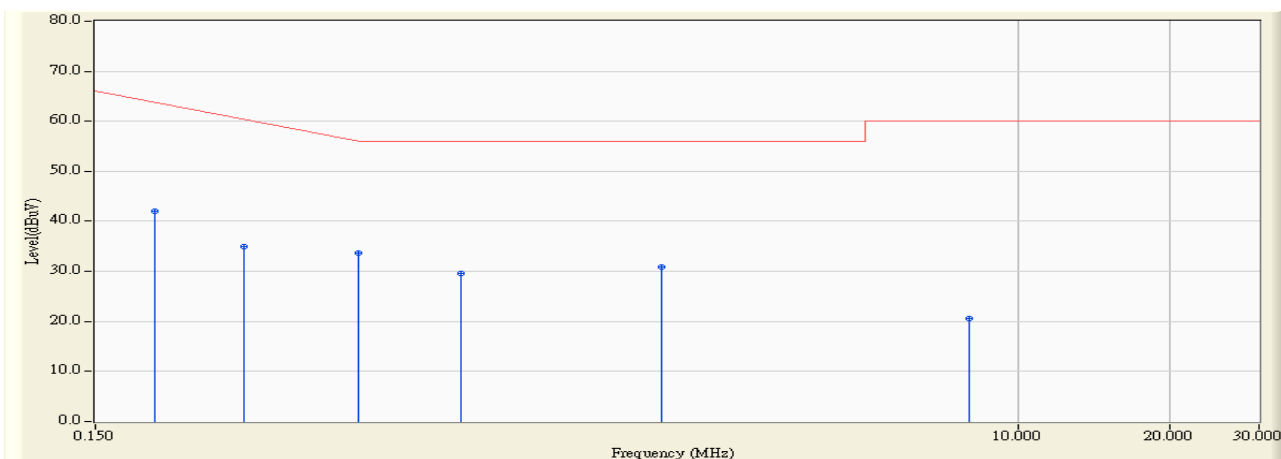

		Frequency (MHz)	Correct Factor (dB)	Reading Level (dBuV)	Measure Level (dBuV)	Margin (dB)	Limit (dBuV)	Detector Type
1		0.197	0.153	41.990	42.143	-22.514	64.657	QUASIPeAK
2		0.295	0.175	34.690	34.865	-26.992	61.857	QUASIPeAK
3	*	0.498	0.210	33.470	33.680	-22.377	56.057	QUASIPeAK
4		0.795	0.220	29.380	29.600	-26.400	56.000	QUASIPeAK
5		1.982	0.290	30.520	30.810	-25.190	56.000	QUASIPeAK
6		8.021	0.630	19.950	20.580	-39.420	60.000	QUASIPeAK

Note:

1. All Reading Levels are Quasi-Peak and average value.
2. " * ", means this data is the worst emission level.
3. Measurement Level = Reading Level + Correct Factor.

Site : Quietek Shielding Room2	Time : 2006/12/11 - 10:27
Limit : CISPR_B_00M_AV	Margin : 0
EUT : Digital Still Camera	Probe : SR3_LISN(16A) - Line2
Power : AC 120V/60Hz	Note : Mode 3: USB LCD on

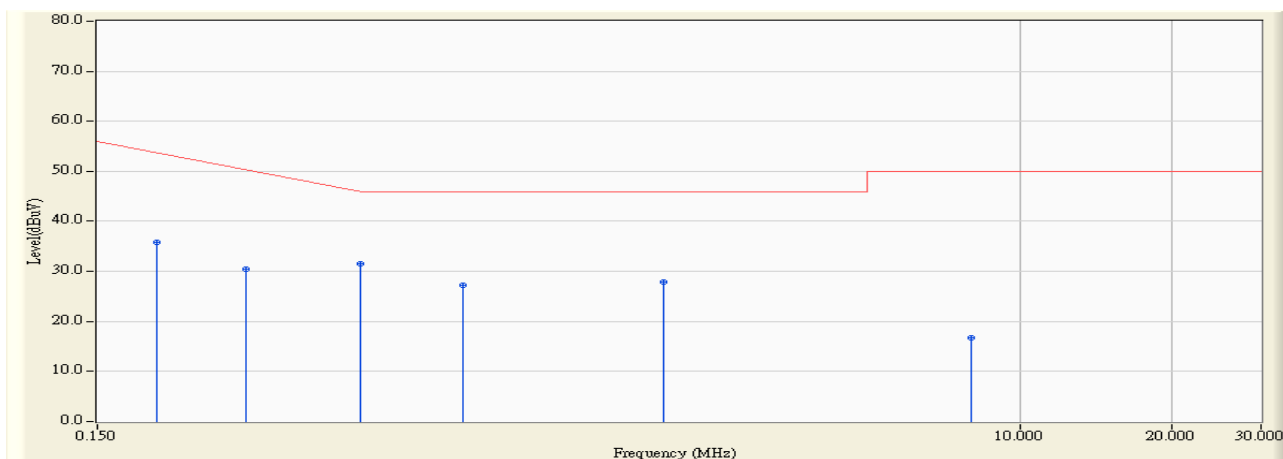

		Frequency (MHz)	Correct Factor (dB)	Reading Level (dBuV)	Measure Level (dBuV)	Margin (dB)	Limit (dBuV)	Detector Type
1		0.197	0.153	35.570	35.723	-18.934	54.657	AVERAGE
2		0.295	0.175	30.190	30.365	-21.492	51.857	AVERAGE
3	*	0.498	0.210	31.310	31.520	-14.537	46.057	AVERAGE
4		0.795	0.220	27.020	27.240	-18.760	46.000	AVERAGE
5		1.982	0.290	27.530	27.820	-18.180	46.000	AVERAGE
6		8.021	0.630	16.060	16.690	-33.310	50.000	AVERAGE

Note:

1. All Reading Levels are Quasi-Peak and average value.
2. " * ", means this data is the worst emission level.
3. Measurement Level = Reading Level + Correct Factor.

4. Radiated Emission

4.1. Test Specification

According to EMC Standard: FCC Part 15 Subpart B, ANSI C63.4

4.2. Test Setup

Under 1GHz Test Setup:

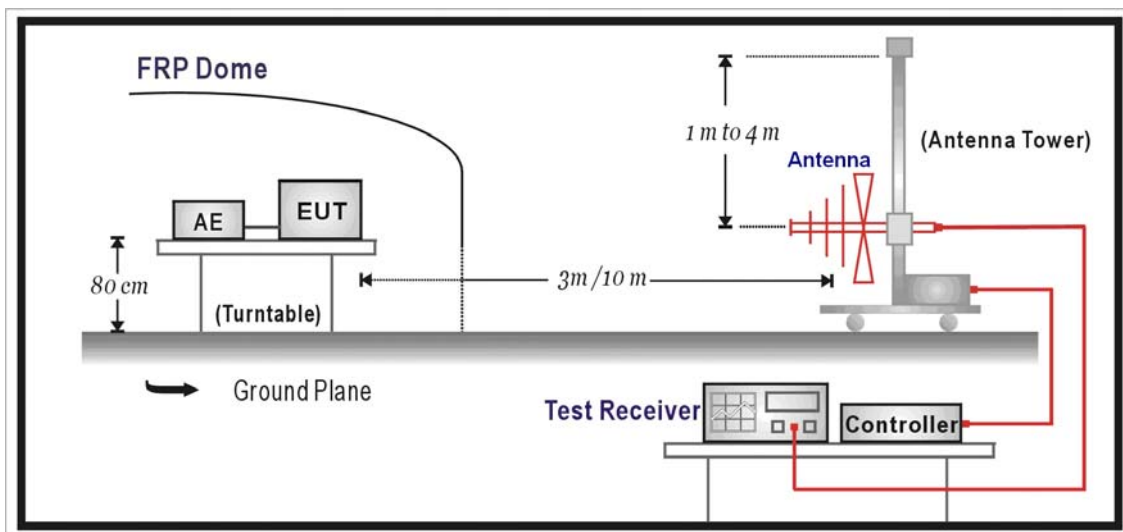

Above 1GHz Test Setup:

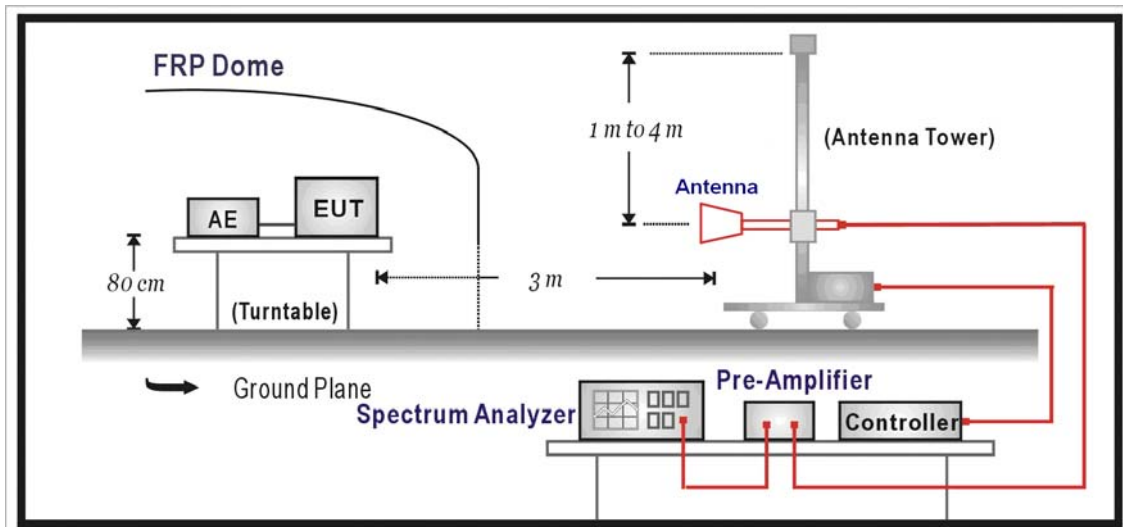

4.3. Limit

FCC Part 15 Subpart B Paragraph 15.109 Limits (dBuV/m)		
Frequency (MHz)	Distance (m)	dBuV/m
30-88	3	40
88-216	3	43.5
216-960	3	46
Above 960	3	54

Remark:

1. The tighter limit shall apply at the edge between two frequency bands.
2. Distance refers to the distance in meters between the measuring instrument antenna and the closed point of any part of the device or system.
3. RF Voltage (dBuV/m) = 20 log RF Voltage (uV/m)

4.4. Test Procedure

The EUT and its simulators are placed on a turn table which is 0.8 meter above ground.

The turn table can rotate 360 degrees to determine the position of the maximum emission level and the antenna can move up and down between 1 meter and 4 meters to find out the maximum emission level.

Both horizontal and vertical polarization of the antenna are set on measurement. In order to find the maximum emission, all of the interface cables must be manipulated on radiated measurement.

For an unintentional radiator, including a digital device, the spectrum shall be investigated from the lowest radio frequency signal generated or used in the device, without going below the lowest frequency for which a radiated emission limit is specified, up to the frequency shown in the following table:

Highest frequency generated or used in the device or on which the device operates or tunes (MHz)	Upper frequency of measurement range (MHz)
Below 1.705	30
1.705 – 108	1000
108 – 500	2000
500 – 1000	5000
Above 1000	5 th harmonic of the highest frequency or 40 GHz, whichever is lower

On any frequency or frequencies below or equal to 1000 MHz, the radiated limits shown are based on measuring equipment employing a quasi-peak detector function and above 1000 MHz, the radiated limits shown are based measuring equipment employing an average detector function.

When average radiated emission measurement are included emission measurement Above 1000 MHz, there also is a limit on the radio frequency emissions, as measured using instrumentation with a peak detector function, corresponding to 20 dB above the maximum permitted average limit.

For class A, the measurement distance between the EUT and antenna is 10 meters for under 1GHz and above 1GHz.

For class B, the measurement distance between the EUT and antenna is 3 meters for under 1GHz and 3 meters for above 1GHz.

The bandwidth below 1GHz setting on the field strength meter (R&S Test Receiver ESCS 30) is 120 kHz and above 1GHz is 1MHz.

4.5. Test Result

Site : Site 2	Time : 2006/12/13 - 10:05
Limit : FCC_CLASS_B_03M_QP	Margin : 6
EUT : Digital Still Camera	Probe : PRO 06-03-29 ST2 - HORIZONTAL
Power : AC 120V/60Hz	Note : Mode 1: Slide Show

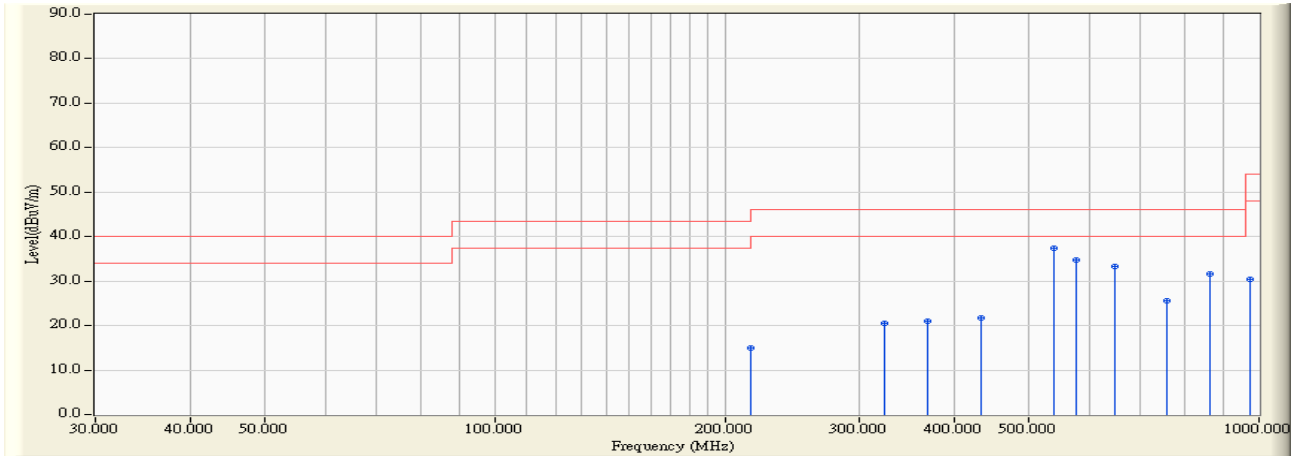

	Frequency (MHz)	Correct Factor (dB)	Reading Level (dBuV)	Measure Level (dBuV/m)	Margin (dB)	Limit (dBuV/m)	Detector Type	Ant Pos (cm)	Table Pos (deg)
1	216.000	11.315	3.700	15.015	-28.485	43.500	QUASIPeAK	100.000	17.000
2	324.000	16.100	4.510	20.610	-25.390	46.000	QUASIPeAK	100.000	142.000
3	367.675	17.020	4.020	21.040	-24.960	46.000	QUASIPeAK	100.000	200.000
4	432.000	17.935	3.670	21.605	-24.395	46.000	QUASIPeAK	100.000	125.000
5	* 540.000	19.743	17.710	37.453	-8.547	46.000	QUASIPeAK	100.000	33.000
6	576.000	19.925	14.780	34.705	-11.295	46.000	QUASIPeAK	100.000	37.000
7	648.000	23.202	10.210	33.412	-12.588	46.000	QUASIPeAK	100.000	-179.000
8	756.000	22.037	3.440	25.477	-20.523	46.000	QUASIPeAK	100.000	53.000
9	864.000	23.652	7.960	31.612	-14.388	46.000	QUASIPeAK	100.000	-21.000
10	972.000	26.445	3.860	30.305	-23.695	54.000	QUASIPeAK	100.000	113.000

Note:

1. All Reading Levels are Quasi-Peak value.
2. “ * ”, means this data is the worst emission level.
3. Measurement Level = Reading Level + Correct Factor.

Site : Site 2	Time : 2006/12/18 - 11:57
Limit : FCC_B_(Above_1G)_3M_AV	Margin : 6
EUT : Digital Still Camera	Probe : FCC_RF_1G-18G(2005-3) - HORIZONTAL
Power : AC 120V/60Hz	Note : Mode 1: Slide Show

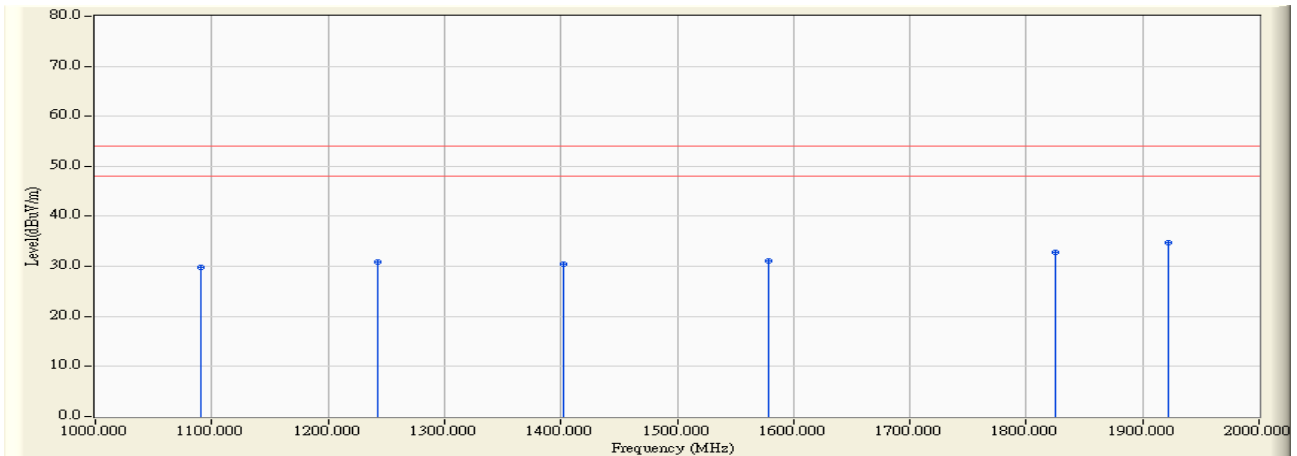

	Frequency (MHz)	Correct Factor (dB)	Reading Level (dBuV)	Measure Level (dBuV/m)	Margin (dB)	Limit (dBuV/m)	Detector Type
1	1090.180	-9.658	39.560	29.902	-24.098	54.000	PEAK
2	1242.483	-9.078	40.010	30.933	-23.067	54.000	PEAK
3	1402.800	-8.489	39.000	30.511	-23.489	54.000	PEAK
4	1579.150	-7.751	38.860	31.109	-22.891	54.000	PEAK
5	1825.650	-6.644	39.420	32.776	-21.224	54.000	PEAK
6	* 1921.840	-5.001	39.640	34.639	-19.361	54.000	PEAK

Note:

1. All Readings below 1GHz are Quasi-Peak, above are performed with peak and/or average measurements as necessary.
2. “ * ”, means this data is the worst emission level.
3. Measurement Level = Reading Level + Correct Factor.
4. The average measurement was not performed when the peak measured data under the limit of average detection. If the readings given are average, peak measurement should also be supplied.

Site : Site 2	Time : 2006/12/13 - 09:47
Limit : FCC_CLASS_B_03M_QP	Margin : 6
EUT : Digital Still Camera	Probe : PRO 06-03-29 ST2 - VERTICAL
Power : AC 120V/60Hz	Note : Mode 1: Slide Show

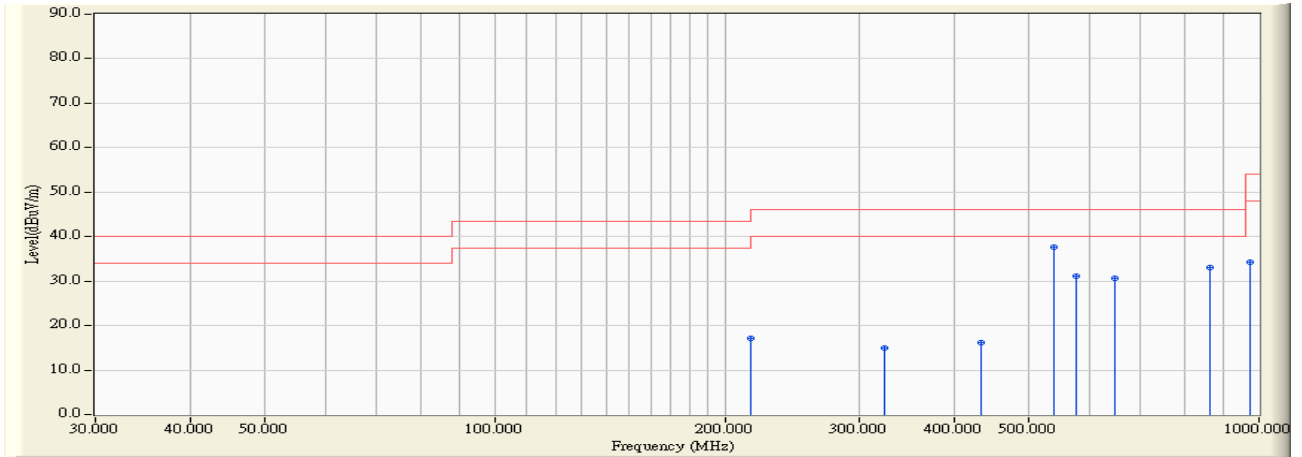

	Frequency (MHz)	Correct Factor (dB)	Reading Level (dBuV)	Measure Level (dBuV/m)	Margin (dB)	Limit (dBuV/m)	Detector Type	Ant Pos (cm)	Table Pos (deg)
1	216.000	11.221	5.840	17.061	-26.439	43.500	QUASPEAK	100.000	114.000
2	324.000	13.372	1.610	14.982	-31.018	46.000	QUASPEAK	100.000	14.000
3	432.000	15.636	0.430	16.066	-29.934	46.000	QUASPEAK	100.000	-55.000
4	* 540.000	21.850	15.870	37.720	-8.280	46.000	QUASPEAK	142.000	132.000
5	576.000	20.798	10.210	31.008	-14.992	46.000	QUASPEAK	142.000	141.000
6	648.000	21.154	9.410	30.564	-15.436	46.000	QUASPEAK	100.000	-201.000
7	864.000	24.115	8.960	33.075	-12.925	46.000	QUASPEAK	101.000	-127.000
8	972.000	24.972	9.240	34.212	-19.788	54.000	QUASPEAK	100.000	37.000

Note:

1. All Reading Levels are Quasi-Peak value.
2. “ * ”, means this data is the worst emission level.
3. Measurement Level = Reading Level + Correct Factor.

Site : Site 2	Time : 2006/12/18 - 12:01
Limit : FCC_B_(Above_1G)_3M_AV	Margin : 6
EUT : Digital Still Camera	Probe : FCC_RF_1G-18G(2005-3) - VERTICAL
Power : AC 120V/60Hz	Note : Mode 1: Slide Show

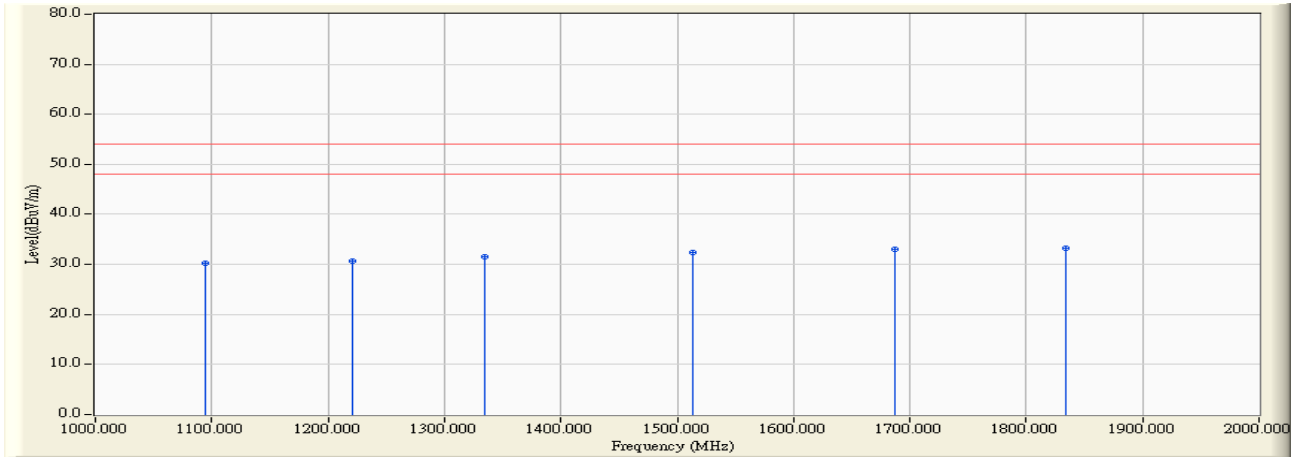

	Frequency (MHz)	Correct Factor (dB)	Reading Level (dBuV)	Measure Level (dBuV/m)	Margin (dB)	Limit (dBuV/m)	Detector Type
1	1094.180	-8.873	39.160	30.288	-23.712	54.000	PEAK
2	1220.440	-8.650	39.232	30.582	-23.418	54.000	PEAK
3	1334.660	-7.911	39.510	31.599	-22.401	54.000	PEAK
4	1513.020	-7.219	39.650	32.431	-21.569	54.000	PEAK
5	1687.373	-6.561	39.680	33.120	-20.880	54.000	PEAK
6	* 1833.660	-6.231	39.430	33.199	-20.801	54.000	PEAK

Note:

1. All Readings below 1GHz are Quasi-Peak, above are performed with peak and/or average measurements as necessary.
2. “ * ”, means this data is the worst emission level.
3. Measurement Level = Reading Level + Correct Factor.
4. The average measurement was not performed when the peak measured data under the limit of average detection. If the readings given are average, peak measurement should also be supplied.

Site : Site 2	Time : 2006/12/12 - 14:22
Limit : FCC_CLASS_B_03M_QP	Margin : 6
EUT : Digital Still Camera	Probe : PRO 06-03-29 ST2 - HORIZONTAL
Power : AC 120V/60Hz	Note : Mode 2: REC

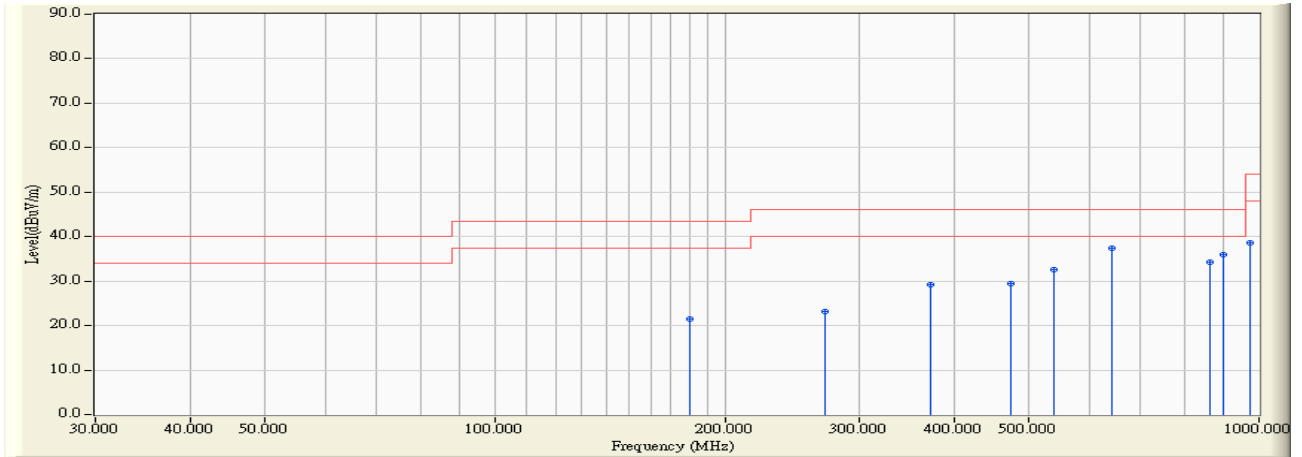

	Frequency (MHz)	Correct Factor (dB)	Reading Level (dBuV)	Measure Level (dBuV/m)	Margin (dB)	Limit (dBuV/m)	Detector Type	Ant Pos (cm)	Table Pos (deg)
1	180.000	9.975	11.600	21.575	-21.925	43.500	QUASIPeAK	266.000	144.000
2	270.000	14.777	8.430	23.207	-22.793	46.000	QUASIPeAK	257.000	200.000
3	371.250	16.774	12.370	29.144	-16.856	46.000	QUASIPeAK	256.000	57.000
4	472.500	18.419	11.030	29.449	-16.551	46.000	QUASIPeAK	172.000	201.000
5	540.000	19.743	12.890	32.633	-13.367	46.000	QUASIPeAK	148.000	-158.000
6	* 641.250	23.605	13.710	37.315	-8.685	46.000	QUASIPeAK	127.000	181.000
7	864.000	23.652	10.610	34.262	-11.738	46.000	QUASIPeAK	100.000	-191.000
8	900.000	25.318	10.590	35.908	-10.092	46.000	QUASIPeAK	100.000	170.000
9	972.000	26.445	12.140	38.585	-15.415	54.000	QUASIPeAK	100.000	-116.000

Note:

1. All Reading Levels are Quasi-Peak value.
2. " * ", means this data is the worst emission level.
3. Measurement Level = Reading Level + Correct Factor.

Site : Site 2	Time : 2006/12/18 - 11:38
Limit : FCC_B_(Above_1G)_3M_AV	Margin : 6
EUT : Digital Still Camera	Probe : FCC_RF_1G-18G(2005-3) - HORIZONTAL
Power : AC 120V/60Hz	Note : Mode 2: REC

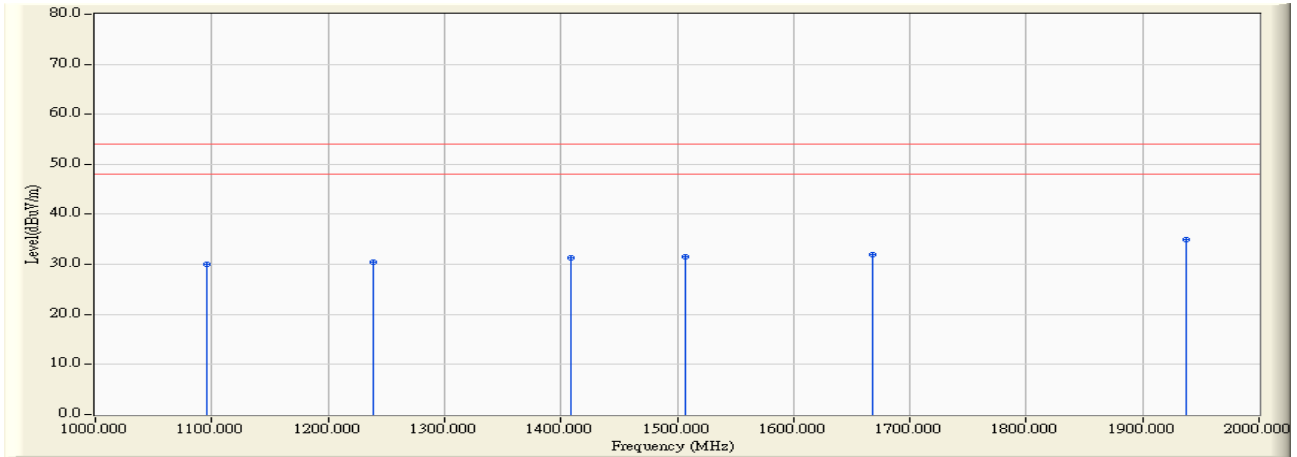

	Frequency (MHz)	Correct Factor (dB)	Reading Level (dBuV)	Measure Level (dBuV/m)	Margin (dB)	Limit (dBuV/m)	Detector Type
1	1096.190	-9.679	39.690	30.011	-23.989	54.000	PEAK
2	1238.470	-9.124	39.500	30.376	-23.624	54.000	PEAK
3	1408.810	-8.480	39.750	31.270	-22.730	54.000	PEAK
4	1507.010	-8.065	39.660	31.595	-22.405	54.000	PEAK
5	1667.330	-7.616	39.490	31.873	-22.127	54.000	PEAK
6	* 1937.870	-4.878	39.760	34.882	-19.118	54.000	PEAK

Note:

1. All Readings below 1GHz are Quasi-Peak, above are performed with peak and/or average measurements as necessary.
2. “ * ”, means this data is the worst emission level.
3. Measurement Level = Reading Level + Correct Factor.
4. The average measurement was not performed when the peak measured data under the limit of average detection. If the readings given are average, peak measurement should also be supplied.

Site : Site 2	Time : 2006/12/12 - 14:07
Limit : FCC_CLASS_B_03M_QP	Margin : 6
EUT : Digital Still Camera	Probe : PRO 06-03-29 ST2 - VERTICAL
Power : AC 120V/60Hz	Note : Mode 2: REC

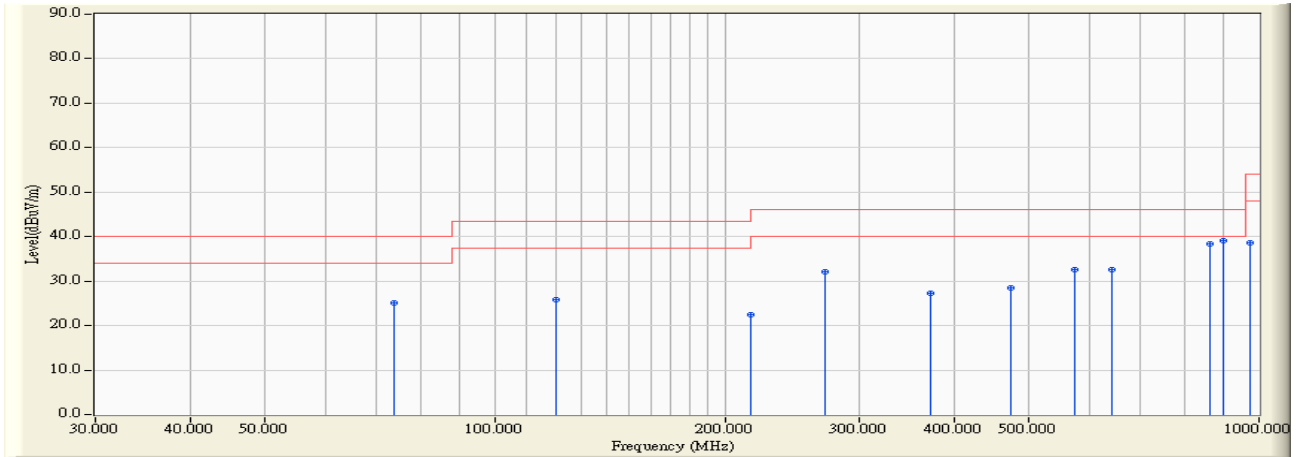

	Frequency (MHz)	Correct Factor (dB)	Reading Level (dBuV)	Measure Level (dBuV/m)	Margin (dB)	Limit (dBuV/m)	Detector Type	Ant Pos (cm)	Table Pos (deg)
1	73.950	8.570	16.410	24.980	-15.020	40.000	QUASPEAK	100.000	-109.000
2	120.000	13.262	12.440	25.702	-17.798	43.500	QUASPEAK	100.000	60.000
3	216.000	11.221	11.170	22.391	-21.109	43.500	QUASPEAK	100.000	-138.000
4	270.000	17.786	14.240	32.026	-13.974	46.000	QUASPEAK	112.000	202.000
5	371.250	15.560	11.700	27.260	-18.740	46.000	QUASPEAK	100.000	20.000
6	472.500	18.604	9.750	28.354	-17.646	46.000	QUASPEAK	124.000	192.000
7	573.750	20.139	12.440	32.579	-13.421	46.000	QUASPEAK	101.000	193.000
8	641.250	21.514	11.180	32.694	-13.306	46.000	QUASPEAK	120.000	101.000
9	864.000	24.115	14.140	38.255	-7.745	46.000	QUASPEAK	115.000	188.000
10	* 900.000	24.116	15.070	39.186	-6.814	46.000	QUASPEAK	123.000	-186.000
11	972.000	24.972	13.560	38.532	-15.468	54.000	QUASPEAK	125.000	-200.000

Note:

1. All Reading Levels are Quasi-Peak value.
2. “ * ”, means this data is the worst emission level.
3. Measurement Level = Reading Level + Correct Factor.

Site : Site 2	Time : 2006/12/18 - 11:43
Limit : FCC_B_(Above_1G)_3M_AV	Margin : 6
EUT : Digital Still Camera	Probe : FCC_RF_1G-18G(2005-3) - VERTICAL
Power : AC 120V/60Hz	Note : Mode 2: REC

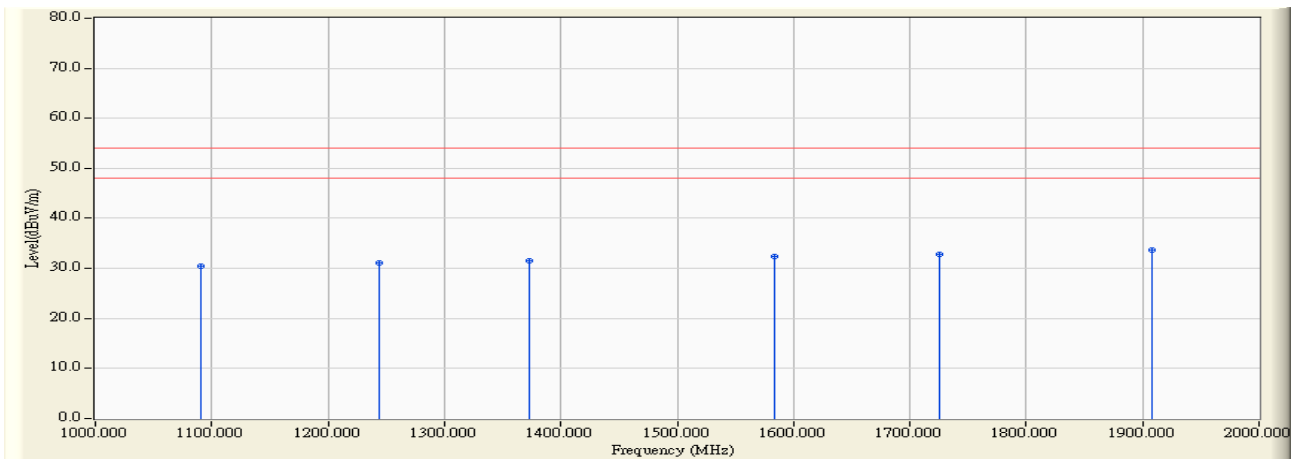

		Frequency (MHz)	Correct Factor (dB)	Reading Level (dBuV)	Measure Level (dBuV/m)	Margin (dB)	Limit (dBuV/m)	Detector Type
1		1090.180	-8.858	39.270	30.412	-23.588	54.000	PEAK
2		1244.440	-8.254	39.260	31.006	-22.994	54.000	PEAK
3		1372.740	-7.828	39.440	31.611	-22.389	54.000	PEAK
4		1583.160	-6.992	39.360	32.368	-21.632	54.000	PEAK
5		1725.450	-6.294	39.150	32.856	-21.144	54.000	PEAK
6	*	1907.810	-5.658	39.280	33.622	-20.378	54.000	PEAK

Note:

1. All Readings below 1GHz are Quasi-Peak, above are performed with peak and/or average measurements as necessary.
2. “ * ”, means this data is the worst emission level.
3. Measurement Level = Reading Level + Correct Factor.
4. The average measurement was not performed when the peak measured data under the limit of average detection. If the readings given are average, peak measurement should also be supplied.

Site : Site 2	Time : 2006/12/12 - 13:42
Limit : FCC_CLASS_B_03M_QP	Margin : 6
EUT : Digital Still Camera	Probe : PRO 06-03-29 ST2 - HORIZONTAL
Power : AC 120V/60Hz	Note : Mode 3: USB LCD on

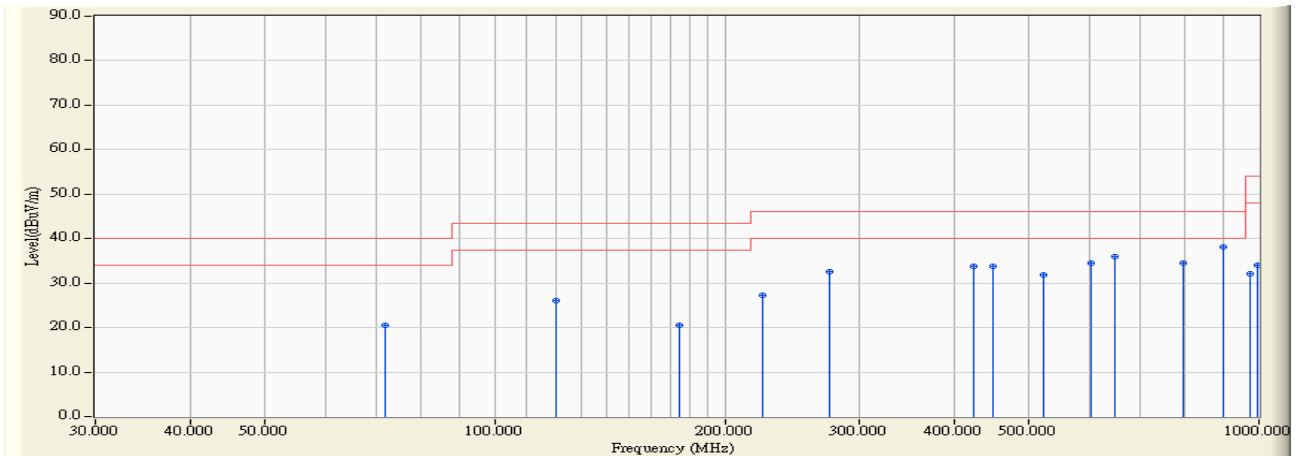

	Frequency (MHz)	Correct Factor (dB)	Reading Level (dBuV)	Measure Level (dBuV/m)	Margin (dB)	Limit (dBuV/m)	Detector Type	Ant Pos (cm)	Table Pos (deg)
1	72.000	7.445	13.000	20.445	-19.555	40.000	QUASIPeAK	259.000	201.000
2	120.000	13.932	12.060	25.992	-17.508	43.500	QUASIPeAK	281.000	-148.000
3	174.450	11.043	9.420	20.463	-23.037	43.500	QUASIPeAK	222.000	201.000
4	224.300	11.788	15.370	27.158	-18.842	46.000	QUASIPeAK	130.000	-161.000
5	274.150	13.913	18.710	32.623	-13.377	46.000	QUASIPeAK	168.000	-200.000
6	423.700	18.532	15.260	33.792	-12.208	46.000	QUASIPeAK	100.000	45.000
7	448.625	17.697	16.010	33.707	-12.293	46.000	QUASIPeAK	100.000	-41.000
8	523.375	18.802	13.000	31.802	-14.198	46.000	QUASIPeAK	100.000	6.000
9	601.525	19.564	14.880	34.444	-11.556	46.000	QUASIPeAK	100.000	31.000
10	648.000	23.202	12.750	35.952	-10.048	46.000	QUASIPeAK	101.000	-200.000
11	797.550	21.869	12.570	34.439	-11.561	46.000	QUASIPeAK	100.000	-112.000
12	* 900.000	25.318	12.840	38.158	-7.842	46.000	QUASIPeAK	100.000	172.000
13	972.000	26.445	5.690	32.135	-21.865	54.000	QUASIPeAK	100.000	93.000
14	996.925	25.884	8.050	33.934	-20.066	54.000	QUASIPeAK	100.000	-200.000

Note:

1. All Reading Levels are Quasi-Peak value.
2. “ * ”, means this data is the worst emission level.
3. Measurement Level = Reading Level + Correct Factor.

Site : Site 2	Time : 2006/12/18 - 11:52
Limit : FCC_B_(Above_1G)_3M_AV	Margin : 6
EUT : Digital Still Camera	Probe : FCC_RF_1G-18G(2005-3) - HORIZONTAL
Power : AC 120V/60Hz	Note : Mode 3: USB LCD on

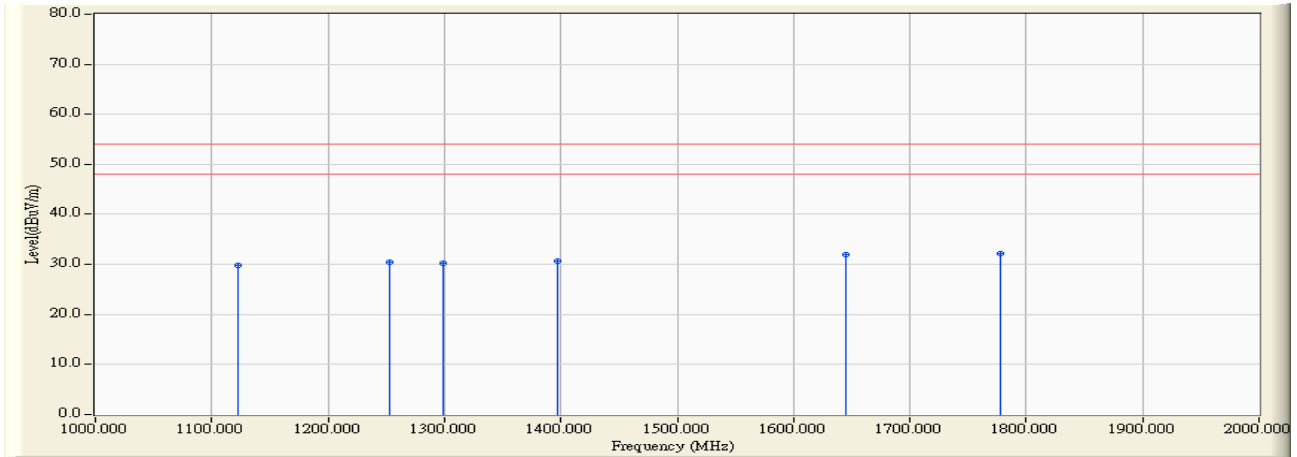

	Frequency (MHz)	Correct Factor (dB)	Reading Level (dBuV)	Measure Level (dBuV/m)	Margin (dB)	Limit (dBuV/m)	Detector Type
1	1122.220	-9.455	39.313	29.858	-24.142	54.000	PEAK
2	1252.500	-8.960	39.360	30.401	-23.599	54.000	PEAK
3	1298.590	-8.855	39.100	30.246	-23.754	54.000	PEAK
4	1396.790	-8.500	39.230	30.730	-23.270	54.000	PEAK
5	1645.290	-7.566	39.540	31.973	-22.027	54.000	PEAK
6	* 1777.550	-7.083	39.360	32.278	-21.722	54.000	PEAK

Note:

1. All Readings below 1GHz are Quasi-Peak, above are performed with peak and/or average measurements as necessary.
2. “ * ”, means this data is the worst emission level.
3. Measurement Level = Reading Level + Correct Factor.
4. The average measurement was not performed when the peak measured data under the limit of average detection. If the readings given are average, peak measurement should also be supplied.

Site : Site 2	Time : 2006/12/12 - 13:17
Limit : FCC_CLASS_B_03M_QP	Margin : 6
EUT : Digital Still Camera	Probe : PRO 06-03-29 ST2 - VERTICAL
Power : AC 120V/60Hz	Note : Mode 3: USB LCD on

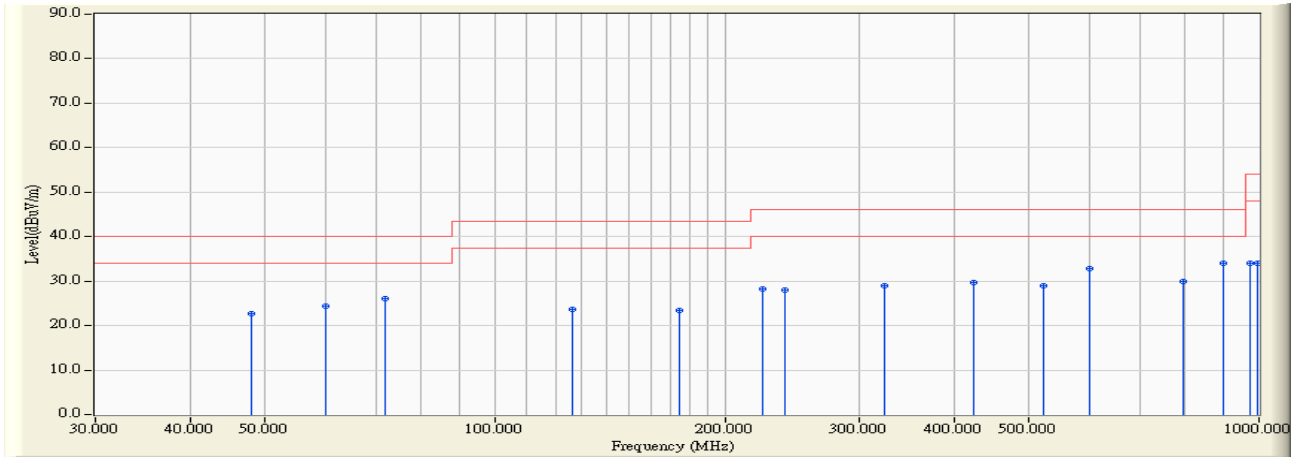

	Frequency (MHz)	Correct Factor (dB)	Reading Level (dBuV)	Measure Level (dBuV/m)	Margin (dB)	Limit (dBuV/m)	Detector Type	Ant Pos (cm)	Table Pos (deg)
1	48.000	7.704	15.000	22.704	-17.296	40.000	QUASIPeAK	100.000	151.000
2	60.000	8.410	16.040	24.450	-15.550	40.000	QUASIPeAK	100.000	116.000
3	72.000	9.703	16.250	25.953	-14.047	40.000	QUASIPeAK	100.000	-201.000
4	126.200	13.597	10.000	23.597	-19.903	43.500	QUASIPeAK	100.000	-136.000
5	174.450	10.192	13.230	23.422	-20.078	43.500	QUASIPeAK	100.000	-101.000
6	224.300	11.926	16.390	28.316	-17.684	46.000	QUASIPeAK	112.000	203.000
7	240.000	14.140	13.850	27.990	-18.010	46.000	QUASIPeAK	107.000	6.000
8	324.000	13.372	15.580	28.952	-17.048	46.000	QUASIPeAK	100.000	146.000
9	423.700	16.170	13.470	29.640	-16.360	46.000	QUASIPeAK	106.000	-151.000
10	523.375	19.564	9.490	29.054	-16.946	46.000	QUASIPeAK	146.000	63.000
11	601.500	20.597	12.210	32.807	-13.193	46.000	QUASIPeAK	170.000	-149.000
12	797.550	19.374	10.640	30.014	-15.986	46.000	QUASIPeAK	135.000	134.000
13	* 900.000	24.116	9.890	34.006	-11.994	46.000	QUASIPeAK	125.000	-157.000
14	972.000	24.972	9.060	34.032	-19.968	54.000	QUASIPeAK	125.000	182.000
15	996.925	23.272	10.730	34.002	-19.998	54.000	QUASIPeAK	125.000	179.000

Note:

1. All Reading Levels are Quasi-Peak value.
2. “ * ”, means this data is the worst emission level.
3. Measurement Level = Reading Level + Correct Factor.

Site : Site 2	Time : 2006/12/18 - 11:48
Limit : FCC_B_(Above_1G)_3M_AV	Margin : 6
EUT : Digital Still Camera	Probe : FCC_RF_1G-18G(2005-3) - VERTICAL
Power : AC 120V/60Hz	Note : Mode 3: USB LCD on

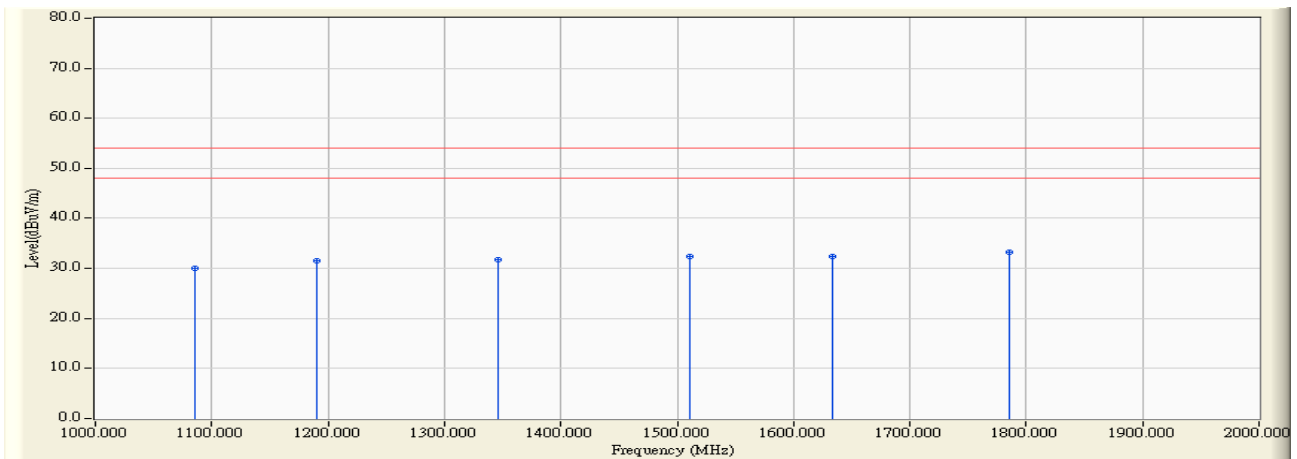

		Frequency (MHz)	Correct Factor (dB)	Reading Level (dBuV)	Measure Level (dBuV/m)	Margin (dB)	Limit (dBuV/m)	Detector Type
1		1086.170	-8.844	38.810	29.966	-24.034	54.000	PEAK
2		1190.380	-8.294	39.820	31.526	-22.474	54.000	PEAK
3		1346.690	-7.883	39.520	31.637	-22.363	54.000	PEAK
4		1511.020	-7.232	39.620	32.387	-21.613	54.000	PEAK
5		1633.260	-6.879	39.180	32.300	-21.700	54.000	PEAK
6	*	1785.570	-6.190	39.430	33.240	-20.760	54.000	PEAK

Note:

1. All Readings below 1GHz are Quasi-Peak, above are performed with peak and/or average measurements as necessary.
2. “ * ”, means this data is the worst emission level.
3. Measurement Level = Reading Level + Correct Factor.
4. The average measurement was not performed when the peak measured data under the limit of average detection. If the readings given are average, peak measurement should also be supplied.

Site : Site 2	Time : 2006/12/13 - 10:39
Limit : FCC_CLASS_B_03M_QP	Margin : 6
EUT : Digital Still Camera	Probe : PRO 06-03-29 ST2 - HORIZONTAL
Power : AC 120V/60Hz	Note : Mode 4: Preview

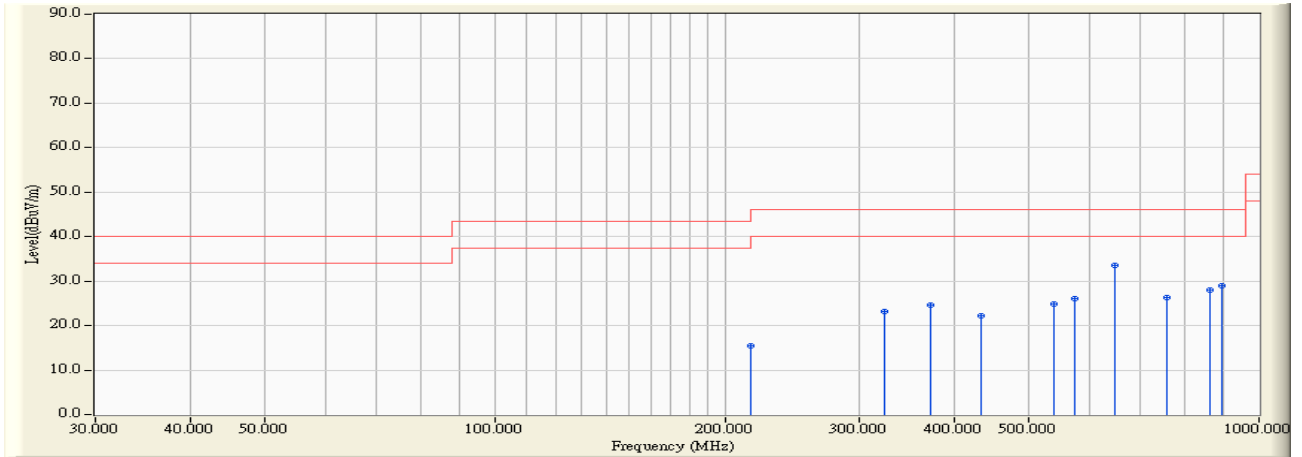

	Frequency (MHz)	Correct Factor (dB)	Reading Level (dBuV)	Measure Level (dBuV/m)	Margin (dB)	Limit (dBuV/m)	Detector Type	Ant Pos (cm)	Table Pos (deg)
1	216.000	11.315	4.160	15.475	-28.025	43.500	QUASIPeAK	100.000	13.000
2	324.000	16.100	7.090	23.190	-22.810	46.000	QUASIPeAK	100.000	-200.000
3	371.250	16.774	7.730	24.504	-21.496	46.000	QUASIPeAK	100.000	-69.000
4	432.000	17.935	4.330	22.265	-23.735	46.000	QUASIPeAK	100.000	-201.000
5	540.000	19.743	5.010	24.753	-21.247	46.000	QUASIPeAK	100.000	-150.000
6	573.750	20.013	6.040	26.053	-19.947	46.000	QUASIPeAK	100.000	29.000
7	* 648.000	23.202	10.370	33.572	-12.428	46.000	QUASIPeAK	100.000	183.000
8	756.000	22.037	4.380	26.417	-19.583	46.000	QUASIPeAK	100.000	-174.000
9	864.000	23.652	4.360	28.012	-17.988	46.000	QUASIPeAK	100.000	-198.000
10	894.375	24.388	4.620	29.008	-16.992	46.000	QUASIPeAK	100.000	-108.000

Note:

1. All Reading Levels are Quasi-Peak value.
2. “ * ”, means this data is the worst emission level.
3. Measurement Level = Reading Level + Correct Factor.

Site : Site 2	Time : 2006/12/18 - 13:12
Limit : FCC_B_(Above_1G)_3M_AV	Margin : 6
EUT : Digital Still Camera	Probe : FCC_RF_1G-18G(2005-3) - HORIZONTAL
Power : AC 120V/60Hz	Note : Mode 4: Preview

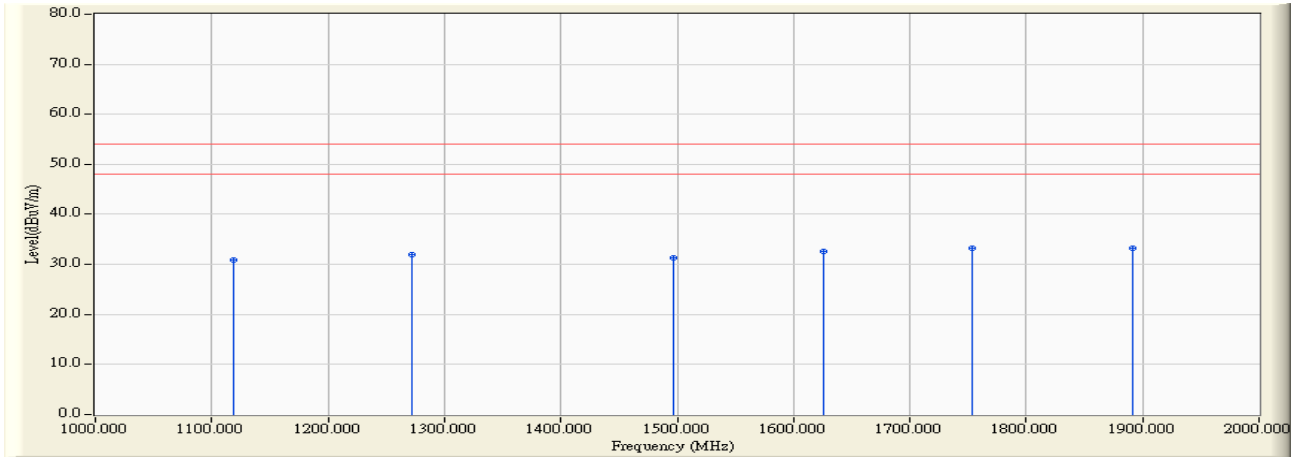

	Frequency (MHz)	Correct Factor (dB)	Reading Level (dBuV)	Measure Level (dBuV/m)	Margin (dB)	Limit (dBuV/m)	Detector Type
1	1118.230	-8.681	39.660	30.980	-23.020	54.000	PEAK
2	1272.540	-8.244	40.120	31.876	-22.124	54.000	PEAK
3	1496.990	-7.347	38.560	31.213	-22.787	54.000	PEAK
4	1625.250	-6.942	39.580	32.638	-21.362	54.000	PEAK
5	* 1753.500	-6.254	39.560	33.306	-20.694	54.000	PEAK
6	1891.780	-6.018	39.260	33.243	-20.757	54.000	PEAK

Note:

1. All Readings below 1GHz are Quasi-Peak, above are performed with peak and/or average measurements as necessary.
2. “ * ”, means this data is the worst emission level.
3. Measurement Level = Reading Level + Correct Factor.
4. The average measurement was not performed when the peak measured data under the limit of average detection. If the readings given are average, peak measurement should also be supplied.

Site : Site 2	Time : 2006/12/13 - 10:27
Limit : FCC_CLASS_B_03M_QP	Margin : 6
EUT : Digital Still Camera	Probe : PRO 06-03-29 ST2 - VERTICAL
Power : AC 120V/60Hz	Note : Mode 4: Preview

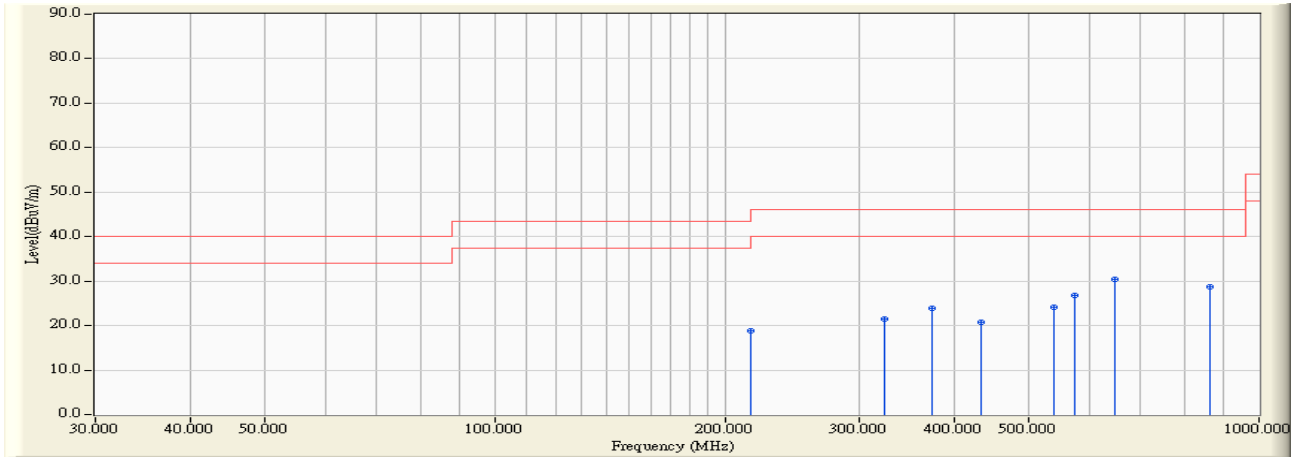

	Frequency (MHz)	Correct Factor (dB)	Reading Level (dBuV)	Measure Level (dBuV/m)	Margin (dB)	Limit (dBuV/m)	Detector Type	Ant Pos (cm)	Table Pos (deg)
1	216.000	11.221	7.720	18.941	-24.559	43.500	QUASPEAK	100.000	-156.000
2	324.000	13.372	8.190	21.562	-24.438	46.000	QUASPEAK	100.000	-84.000
3	373.850	15.988	7.810	23.798	-22.202	46.000	QUASPEAK	100.000	-167.000
4	432.000	15.636	5.190	20.826	-25.174	46.000	QUASPEAK	100.000	-47.000
5	540.000	21.850	2.370	24.220	-21.780	46.000	QUASPEAK	100.000	48.000
6	573.750	20.139	6.680	26.819	-19.181	46.000	QUASPEAK	100.000	-7.000
7	* 648.000	21.154	9.190	30.344	-15.656	46.000	QUASPEAK	100.000	-204.000
8	864.000	24.115	4.660	28.775	-17.225	46.000	QUASPEAK	100.000	-130.000

Note:

1. All Reading Levels are Quasi-Peak value.
2. “ * ”, means this data is the worst emission level.
3. Measurement Level = Reading Level + Correct Factor.

Site : Site 2	Time : 2006/12/18 - 12:05
Limit : FCC_B_(Above_1G)_3M_AV	Margin : 6
EUT : Digital Still Camera	Probe : FCC_RF_1G-18G(2005-3) - VERTICAL
Power : AC 120V/60Hz	Note : Mode 4: Preview

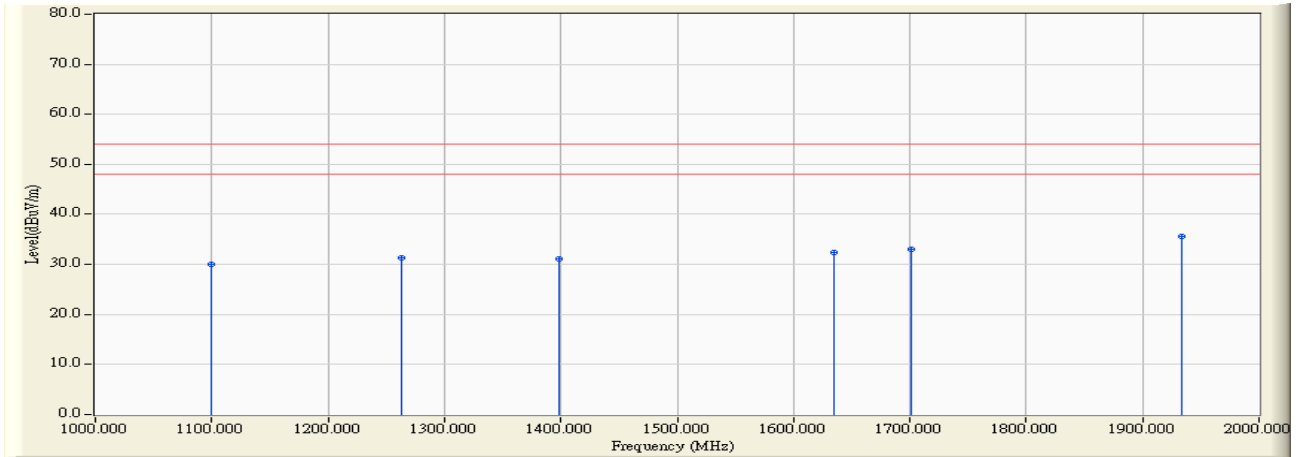

	Frequency (MHz)	Correct Factor (dB)	Reading Level (dBuV)	Measure Level (dBuV/m)	Margin (dB)	Limit (dBuV/m)	Detector Type
1	1100.020	-8.893	39.020	30.127	-23.873	54.000	PEAK
2	1262.520	-8.183	39.430	31.247	-22.753	54.000	PEAK
3	1398.790	-7.696	38.760	31.064	-22.936	54.000	PEAK
4	1635.270	-6.861	39.210	32.349	-21.651	54.000	PEAK
5	1701.400	-6.426	39.380	32.954	-21.046	54.000	PEAK
6	* 1933.860	-5.706	41.270	35.565	-18.435	54.000	PEAK

Note:

1. All Readings below 1GHz are Quasi-Peak, above are performed with peak and/or average measurements as necessary.
2. “ * ”, means this data is the worst emission level.
3. Measurement Level = Reading Level + Correct Factor.
4. The average measurement was not performed when the peak measured data under the limit of average detection. If the readings given are average, peak measurement should also be supplied.