



Test Report

Product Name : Digital Still Camera
Model No. : DSC-S500
FCC ID : TVRDSCS500

Applicant : PREMIER IMAGE TECHNOLOGY CORPORATION
Address : 5F, No.9, LI-SHIN RD. V, SCIENCE-BASED INDUSTRIAL
PARK, HSINCHU, TAIWAN, R.O.C.

Date of Receipt : 2006/03/27
Issued Date : 2006/04/13
Report No. : 064H002-IT-US-P01V02

The test results relate only to the samples tested.

The test results shown in the test report are traceable to the national/international standard through the calibration of the equipment and evaluated measurement uncertainty herein.

This report must not be used to claim product endorsement by CNLA, NVLAP, NIST or any agency of the Government.

The test report shall not be reproduced except in full without the written approval of QuieTek Corporation.

Test Report Certification

Issued Date : 2006/04/13

Report No. : 064H002-IT-US-P01V02



Product Name : Digital Still Camera
Applicant : PREMIER IMAGE TECHNOLOGY CORPORATION
Address : 5F, No.9, LI-SHIN RD. V, SCIENCE-BASED
INDUSTRIAL PARK, HSINCHU, TAIWAN, R.O.C.
Manufacturer : PREMIER IMAGE TECHNOLOGY CORPORATION
Model No. : DSC-S500
Rated Voltage : AC 120 V / 60 Hz
EUT Voltage : AC 120 V / 60 Hz
Trade Name : SONY
Applicable Standard : FCC CFR Title 47 Part 15 Subpart B: 2005 Class B,
CISPR 22: 2005
Test Result : Complied
Performed Location : Hsinchu EMC Laboratory
N0. 75-2, 3rd Lin, Wangye Keng, Yonghxing Tsuen,
Qionglin Shiang, Hsinchu County 307, Taiwan, R.O.C.
TEL:+886-3-592-8858 / FAX:+886-3-592-8859

Documented By : Demi Chang

(Demi Chang)

Reviewed By : Gavin chen

(Gavin Chen)

Approved By : Bob Fang

(Bob Fang)

Laboratory Information

We , **QuietTek Corporation**, are an independent EMC and safety consultancy that was established the whole facility in our laboratories. The test facility has been accredited by the following accreditation Bodies in compliance with ISO 17025, EN 45001 and Guide 25:

Taiwan R.O.C.	: BSMI, DGT, CNLA
Germany	: TÜV Rheinland
Norway	: Nemko, DNV
USA	: FCC, NVLAP
Japan	: VCCI

The related certificate for our laboratories about the test site and management system can be downloaded from QuietTek Corporation's Web Site : <http://tw.quietek.com/modules/myalbum/>
 The address and introduction of QuietTek Corporation's laboratories can be founded in our Web site : <http://www.quietek.com/>
 If you have any comments, Please don't hesitate to contact us. Our contact information is as below:

HsinChu Testing Laboratory :

No.75-2, 3rd Lin, Wangye Keng, Yonghxing Tsuen, Qionglin Shiang, Hsinchu County 307, Taiwan, R.O.C.
 TEL:+886-3-592-8858 / FAX:+886-3-592-8859 E-Mail : service@quietek.com



LinKou Testing Laboratory :

No. 5, Ruei-Shu Valley, Ruei-Ping Tsuen, Lin-Kou Shiang, Taipei, Taiwan, R.O.C.
 TEL : 886-2-8601-3788 / FAX : 886-2-8601-3789 E-Mail : service@quietek.com



TABLE OF CONTENTS

Description	Page
1. General Information	5
1.1. EUT Description	5
1.2. Mode of Operation	6
1.3. Tested System Details.....	7
1.4. Configuration of Tested System	8
1.5. EUT Exercise Software	9
2. Technical Test.....	10
2.1. Summary of Test Result	10
2.2. List of Test Equipment.....	10
2.3. Measurement Uncertainty	11
2.4. Test Environment	11
3. Conducted Emission	12
3.1. Test Specification	12
3.2. Test Setup	12
3.3. Limit.....	12
3.4. Test Procedure	13
3.5. Test Result	14
3.6. Test Photograph	18
4. Radiated Emission	19
4.1. Test Specification	19
4.2. Test Setup	19
4.3. Limit.....	20
4.4. Test Procedure	21
4.5. Test Result	22
4.6. Test Photograph	26
5. Attachment.....	28
EUT Photograph.....	28

1. General Information

1.1. EUT Description

Product Name	Digital Still Camera
Trade Name	SONY
Model No.	DSC-S500
Max Resolution	6.0 Mega Pixels

Component	
AV Cable	Non-Shielded, 1.6m, one ferrite core bonded.
USB Cable	Shielded, 1.6m, one ferrite core bonded.
Battery Cable	Shielded, 0.15m
Power Adapter	SONY, AC-LS5 Cable In: Non-Shielded, 1.8m Power Cord: Non-Shielded, 1.8m

Note:

This EUT is a Digital Still Camera.

1.2. Mode of Operation

QuieTek has verified the construction and function in typical operation. All the test modes were carried out with the EUT in normal operation, which was shown in this test report and defined as:

Pre-Test Mode	
Mode 1:Slide show	
Mode 2:REC	
Mode 3:USB	
Mode 4:Preview	
Mode 5:Internal slide show	
Mode 6:Slide show (LCD ON)	
Final Test Mode	
Emission	Mode 2:REC

1.3. Tested System Details

The types for all equipments, plus descriptions of all cables used in the tested system (including inserted cards) are:

Product	Manufacturer	Model No.	Serial No.	FCC ID	Power Cord
1 Notebook PC	DELL	PP10L	3Y220	E2K24BNHM	Non-Shielded, 1.8m
2 Monitor	SONY	PVM-14M2U	2013141	DoC	Non-Shielded, 1.8m
3 Monitor	CHI MEI	A170E1-09	3UC120955R A0033	DoC	Non-Shielded, 1.8m
4 Digital 8 (D8)	SONY	DCR-TRV110	P35209	DoC	--
5 Microphone & Earphone	Ronald	MOE060	N/A	DoC	--
6 USB 2.0 Flash Memory	Ridata	PEN000-DP065 -37	N/A	DoC	--
7 Modem	ACEEX	DM-1414	0102027545	DoC	Non-Shielded, 1.6m
8 Printer	HP	C2642A	MY75L1D2XN	DoC	Non-Shielded, 0.7m

1.4. Configuration of Tested System

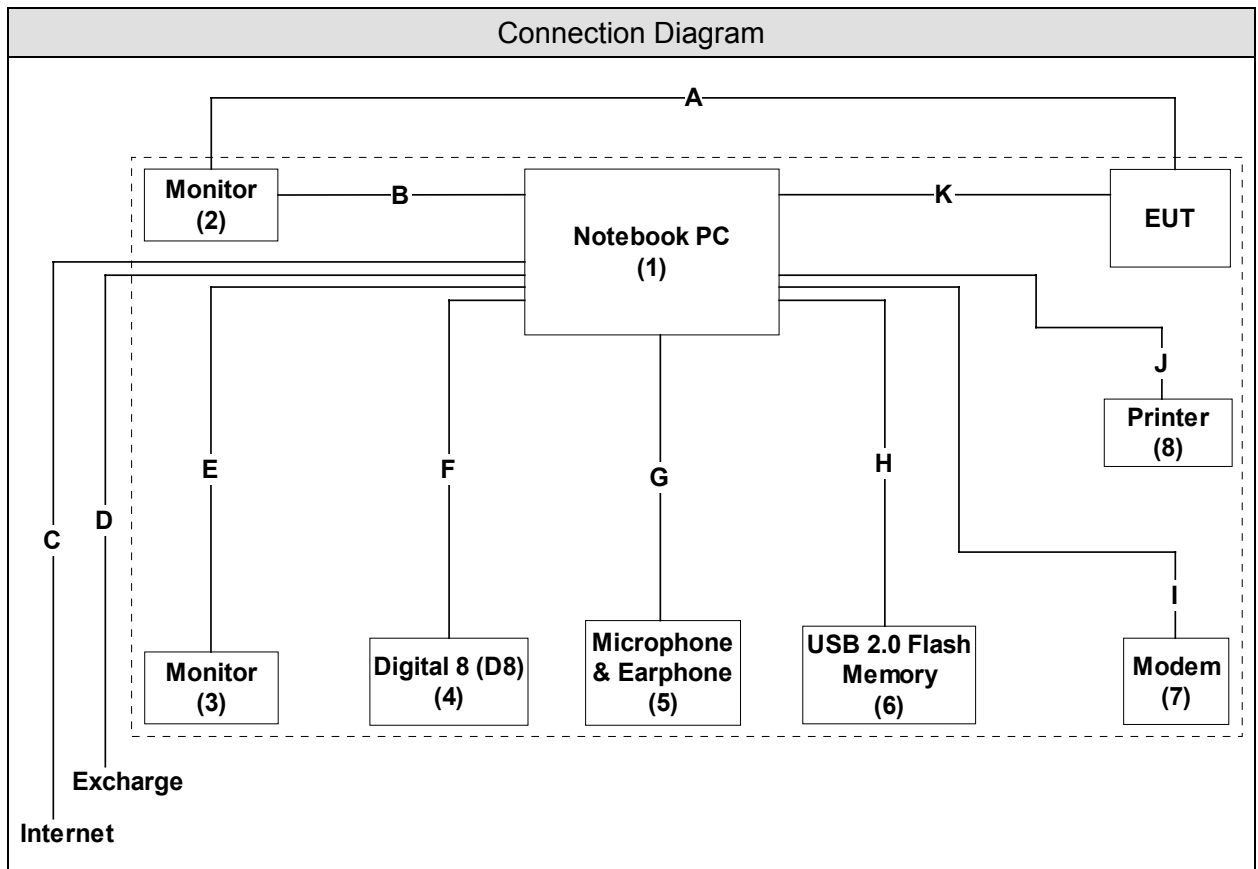

Signal Cable Type		Signal cable Description	Interface
A	AV Cable	Non-Shielded, 1.6m, one ferrite core bonded.	AV Port
B	S-Video Cable	Shielded, 1.6m	S-Video Port
C	LAN Cable	Non-Shielded, 10m	LAN Port
D	Telecom Cable	Non-Shielded, 10m	Telecom Port
E	VGA Cable	Shielded, 1.6m, two ferrite core bonded.	VGA Port
F	1394 Cable	Shielded, 1m	1394 Port
G	Microphone & Earphone Cable	Non-Shielded, 1.6m	Earphone Port
H	USB 2.0 Flash Memory Cable	Shielded, 1m	USB Port
I	Modem Cable	Shielded, 1.5m	RS-232 Port
J	Printer Cable	Shielded, 1.2m	Printer Port
K	USB Cable	Shielded, 1.6m, one ferrite core bonded.	USB Port

1.5. EUT Exercise Software

1	Setup EUT and PC as shown on 1.4.
2	The lens of EUT was covered with black tape.
3	Turn on the power of all equipment.
4	Press REC key.
5	Save black file.

2. Technical Test

2.1. Summary of Test Result

- No deviations from the test standards
- Deviations from the test standards as below description:

Emission			
Performed Item	Normative References	Test Performed	Deviation
Conducted Emission	FCC CFR Title 47 Part 15 Subpart B: 2005 Class B, CISPR 22: 2005, ANSI C63.4: 2003	Yes	No
Radiated Emission	FCC CFR Title 47 Part 15 Subpart B: 2005 Class B, CISPR 22: 2005, ANSI C63.4: 2003	Yes	No

2.2. List of Test Equipment

Conducted Emission / SR2

Instrument	Manufacturer	Type No.	Serial No	Cal. Date
4-Wire ISN	R & S	ENY 41	837032/001	2006/02/25
Artificial Mains Network	R & S	ENV4200	848411/010	2006/02/18
Double 2-Wire ISN	R & S	ENY 22	835354/008	2006/02/25
LISN	R & S	ESH3-Z5	825562/002	2006/02/18
Pulse Limiter	R & S	ZSH3Z2	357.8810.52	2006/02/12
Test Receiver	R & S	ESCS 30	825442/018	2005/09/16

Radiated Emission / Site2

Instrument	Manufacturer	Type No.	Serial No	Cal. Date
Bilog Antenna	Schaffner Chase	CBL6112B	2708	2005/09/03
Horn Antenna	Schwarzbeck	BBHA 9120D	BBHA9120D312	2005/07/29
Pre-Amplifier	QuieTek	QTK-AMP	AMP1	N/A
Pre-Amplifier	HP	8449B	3008A01123	2006/02/15
Spectrum Analyzer	Advantest	R3261C	81720471	2006/02/17
Spectrum Analyzer	R & S	FSP40	100005	2005/08/25
Test Receiver	R & S	ESCS 30	836858/023	2006/02/17

2.3. Measurement Uncertainty

Conducted Emission

The measurement uncertainty is evaluated as ± 2.26 dB.

Radiated Emission

The measurement uncertainty is evaluated as ± 3.19 dB.

2.4. Test Environment

Performed Item	Items	Required	Actual
Conducted Emission	Temperature (°C)	15-35	25
	Humidity (%RH)	25-75	50
	Barometric pressure (mbar)	860-1060	950-1000
Radiated Emission	Temperature (°C)	15-35	25
	Humidity (%RH)	25-75	65
	Barometric pressure (mbar)	860-1060	950-1000

3. Conducted Emission

3.1. Test Specification

According to Standard : FCC Part 15 Subpart B, ANSI C63.4

3.2. Test Setup

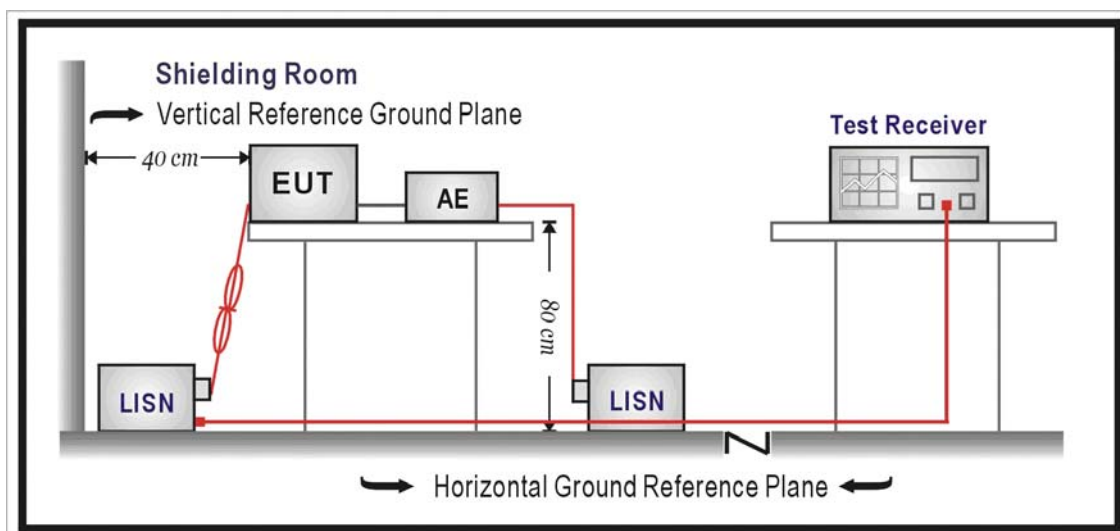

3.3. Limit

Limits		
Frequency (MHz)	QP (dBuV)	AV (dBuV)
0.15 - 0.50	66 - 56	56 - 46
0.50-5.0	56	46
5.0 - 30	60	50

Remarks: In the above table, the tighter limit applies at the band edges.

3.4. Test Procedure

The EUT and simulators are connected to the main power through a line impedance stabilization network (L.I.S.N.). This provides a 50 ohm /50uH coupling impedance for the measuring equipment. The peripheral devices are also connected to the main power through a LISN that provides a 50ohm/50uH coupling impedance with 50ohm termination.

(Please refers to the block diagram of the test setup and photographs.)

Both sides of A.C. line are checked for maximum conducted interference. In order to find the maximum emission, the relative positions of equipment and all of the interface cables must be changed on conducted measurement.

Conducted emissions were invested over the frequency range from 0.15MHz to 30MHz using a receiver bandwidth of 9kHz.

3.5. Test Result

Site : QuieTek Shielding Room 3	Time : 2006/04/06 - 10:04
Limit : CISPR_B_00M_QP	Margin : 0
EUT : DSC-S500	Probe : SR3_LISN(16A) - Line1
Power : AC 120V/60Hz	Note : MODE 2:REC

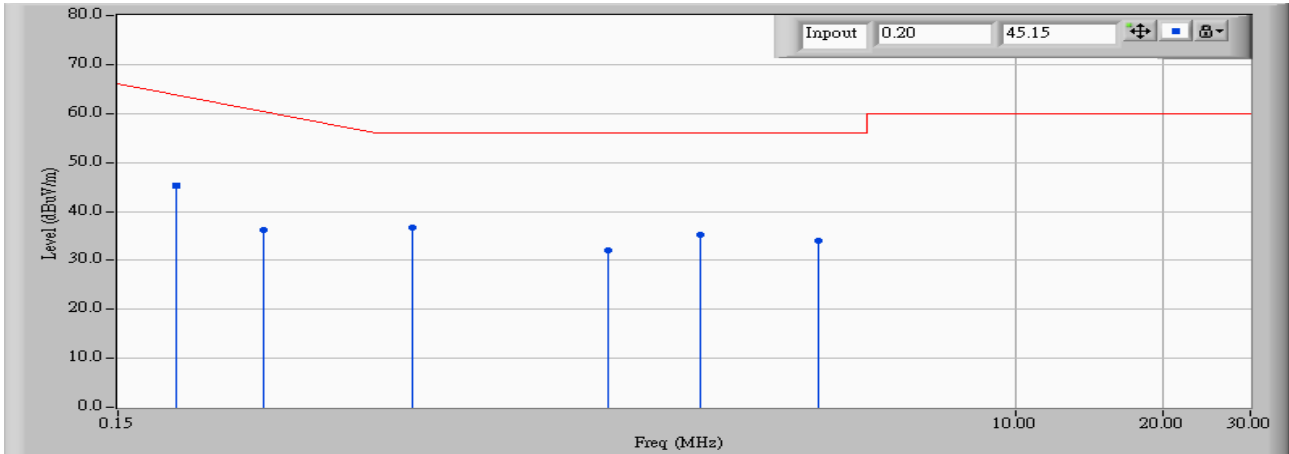

	Frequency (MHz)	Correct Factor (dB)	Reading Level (dBuV)	Measure Level (dBuV)	Margin (dB)	Limit (dBuV)	Detector Type
1	0.197	0.153	45.000	45.153	-19.504	64.657	QUASPEAK
2	0.296	0.176	36.140	36.316	-25.513	61.829	QUASPEAK
3	* 0.595	0.210	36.450	36.660	-19.340	56.000	QUASPEAK
4	1.490	0.260	31.780	32.040	-23.960	56.000	QUASPEAK
5	2.284	0.310	35.040	35.350	-20.650	56.000	QUASPEAK
6	3.977	0.430	33.540	33.970	-22.030	56.000	QUASPEAK

Note:

1. All Reading Levels are Quasi-Peak and average value.
2. " * ", means this data is the worst emission level.
3. Measurement Level = Reading Level + Correct Factor

Site : Quietek Shielding Room 3	Time : 2006/04/06 - 10:04
Limit : CISPR_B_00M_AV	Margin : 0
EUT : DSC-S500	Probe : SR3_LISN(16A) - Line1
Power : AC 120V/60Hz	Note : MODE 2:REC



	Frequency (MHz)	Correct Factor (dB)	Reading Level (dBuV)	Measure Level (dBuV)	Margin (dB)	Limit (dBuV)	Detector Type
1	0.197	0.153	40.050	40.203	-14.454	54.657	AVERAGE
2	0.296	0.176	30.970	31.146	-20.683	51.829	AVERAGE
3	* 0.595	0.210	36.440	36.650	-9.350	46.000	AVERAGE
4	1.490	0.260	31.740	32.000	-14.000	46.000	AVERAGE
5	2.284	0.310	34.030	34.340	-11.660	46.000	AVERAGE
6	3.977	0.430	31.350	31.780	-14.220	46.000	AVERAGE

Note:

1. All Reading Levels are Quasi-Peak and average value.
2. " * ", means this data is the worst emission level.
3. Measurement Level = Reading Level + Correct Factor

Site : Quietek Shielding Room 3	Time : 2006/04/06 - 10:08
Limit : CISPR_B_00M_QP	Margin : 0
EUT : DSC-S500	Probe : SR3_LISN(16A) - Line2
Power : AC 120V/60Hz	Note : MODE 2:REC

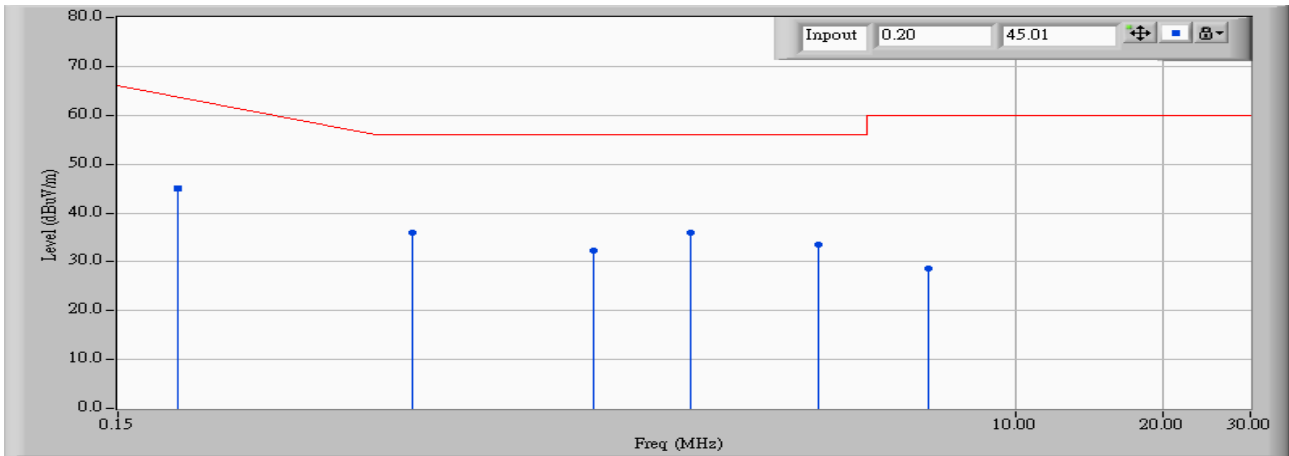

		Frequency (MHz)	Correct Factor (dB)	Reading Level (dBuV)	Measure Level (dBuV)	Margin (dB)	Limit (dBuV)	Detector Type
1	*	0.198	0.153	44.860	45.013	-19.616	64.629	QUASIPeAK
2		0.595	0.210	35.720	35.930	-20.070	56.000	QUASIPeAK
3		1.391	0.251	32.090	32.341	-23.659	56.000	QUASIPeAK
4		2.185	0.310	35.560	35.870	-20.130	56.000	QUASIPeAK
5		3.974	0.430	33.120	33.550	-22.450	56.000	QUASIPeAK
6		6.658	0.570	28.030	28.600	-31.400	60.000	QUASIPeAK

Note:

1. All Reading Levels are Quasi-Peak and average value.
2. " * ", means this data is the worst emission level.
3. Measurement Level = Reading Level + Correct Factor

Site : Quietek Shielding Room 3	Time : 2006/04/06 - 10:08
Limit : CISPR_B_00M_AV	Margin : 0
EUT : DSC-S500	Probe : SR3_LISN(16A) - Line2
Power : AC 120V/60Hz	Note : MODE 2:REC

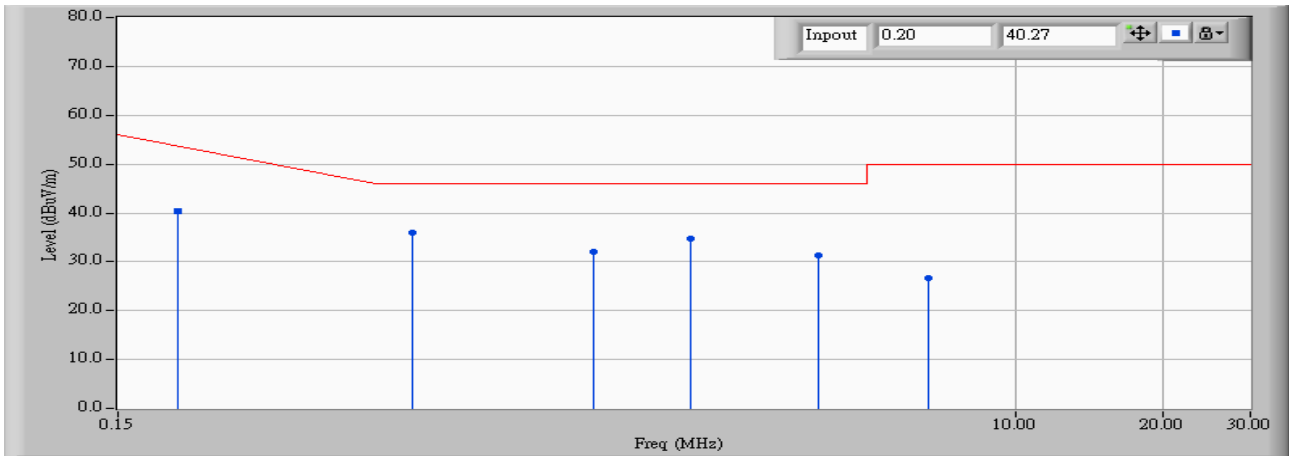

		Frequency (MHz)	Correct Factor (dB)	Reading Level (dBuV)	Measure Level (dBuV)	Margin (dB)	Limit (dBuV)	Detector Type
1		0.198	0.153	40.120	40.273	-14.356	54.629	AVERAGE
2	*	0.595	0.210	35.650	35.860	-10.140	46.000	AVERAGE
3		1.391	0.251	31.890	32.141	-13.859	46.000	AVERAGE
4		2.185	0.310	34.320	34.630	-11.370	46.000	AVERAGE
5		3.974	0.430	30.980	31.410	-14.590	46.000	AVERAGE
6		6.658	0.570	26.140	26.710	-23.290	50.000	AVERAGE

Note:

1. All Reading Levels are Quasi-Peak and average value.
2. " * ", means this data is the worst emission level.
3. Measurement Level = Reading Level + Correct Factor

3.6. Test Photograph

Test Mode : Mode 2:REC

Description : Front View of Conducted Emission Test Setup



Test Mode : Mode 2:REC

Description : Back View of Conducted Emission Test Setup



4. Radiated Emission

4.1. Test Specification

According to EMC Standard : FCC Part 15 Subpart B, ANSI C63.4

4.2. Test Setup

Under 1GHz Test Setup:

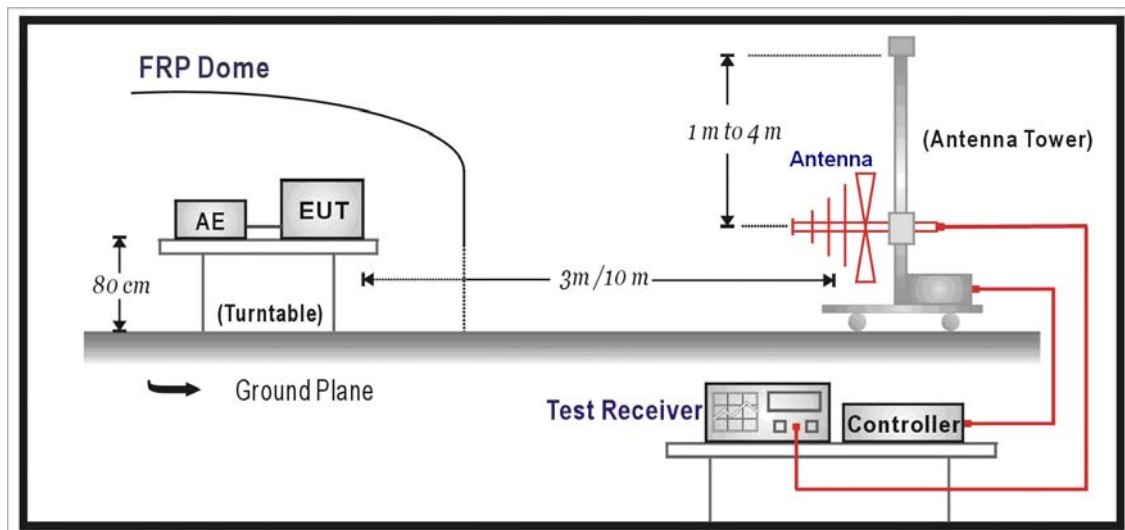

Above 1GHz Test Setup:

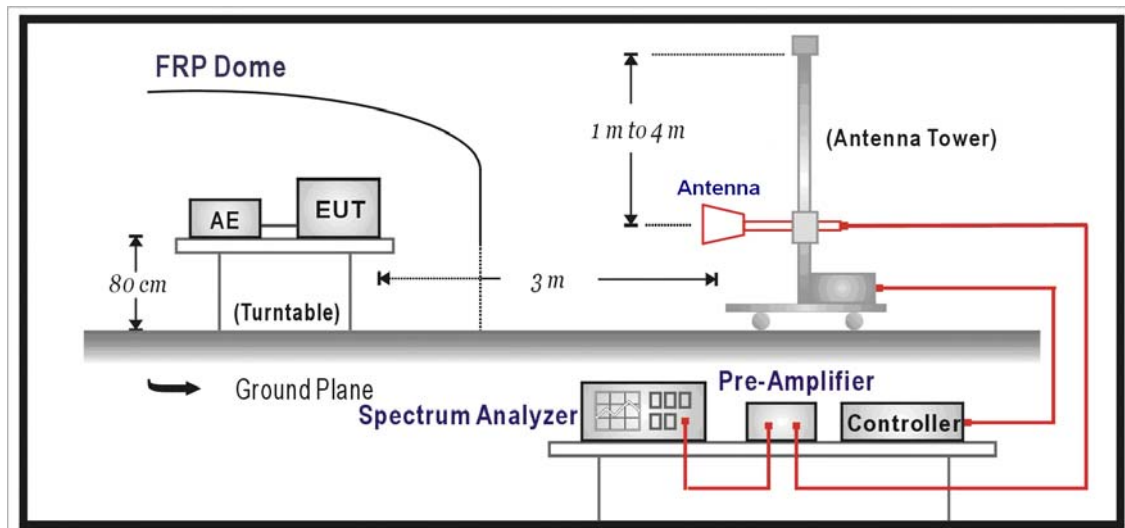

4.3. Limit

Under 1GHz test shall not exceed the following value:

Limits		
Frequency (MHz)	Distance (m)	dBuV/m
30 – 230	10	30
230 – 1000	10	37

Remark:

1. The tighter limit shall apply at the edge between two frequency bands.
2. Distance refers to the distance in meters between the measuring instrument antenna and the closed point of any part of the device or system.

Above 1GHz test shall not exceed the following value:

FCC Part 15 Subpart B Paragraph 15.109 Limits (dBuV/m)		
Frequency (MHz)	Distance (m)	dBuV/m
30-88	3	40
88-216	3	43.5
216-960	3	46
Above 960	3	54

Remark:

1. The tighter limit shall apply at the edge between two frequency bands.
2. Distance refers to the distance in meters between the measuring instrument antenna and the closed point of any part of the device or system.
3. RF Voltage (dBuV/m) = 20 log RF Voltage (uV/m)

4.4. Test Procedure

The EUT and its simulators are placed on a turn table which is 0.8 meter above ground.

The turn table can rotate 360 degrees to determine the position of the maximum emission level and the antenna can move up and down between 1 meter and 4 meters to find out the maximum emission level.

Both horizontal and vertical polarization of the antenna are set on measurement. In order to find the maximum emission, all of the interface cables must be manipulated on radiated measurement.

For an unintentional radiator, including a digital device, the spectrum shall be investigated from the lowest radio frequency signal generated or used in the device, without going below the lowest frequency for which a radiated emission limit is specified, up to the frequency shown in the following table:

Highest frequency generated or used in the device or on which the device operates or tunes (MHz)	Upper frequency of measurement range (MHz)
Below 1.705	30
1.705 – 108	1000
108 – 500	2000
500 – 1000	5000
Above 1000	5 th harmonic of the highest frequency or 40 GHz, whichever is lower

On any frequency or frequencies below or equal to 1000 MHz, the radiated limits shown are based on measuring equipment employing a quasi-peak detector function and above 1000 MHz, the radiated limits shown are based measuring equipment employing an average detector function.

When average radiated emission measurement are included emission measurement Above 1000 MHz, there also is a limit on the radio frequency emissions, as measured using instrumentation with a peak detector function, corresponding to 20 dB above the maximum permitted average limit.

For class A, the measurement distance between the EUT and antenna is 10 meters for under 1GHz and above 1GHz.

For class B, the measurement distance between the EUT and antenna is 10 meters for under 1GHz and 3 meters for above 1GHz.

The bandwidth below 1GHz setting on the field strength meter (R&S Test Receiver ESCS 30) is 120 kHz and above 1GHz is 1MHz.

4.5. Test Result

Site : Quietek SH-Site2	Time : 2006/04/04 - 13:23
Limit : CISPR_B_10M_QP	Margin : 6
EUT : DSC-S500	Probe : PRO 05-10-04 ST2 - HORIZONTAL
Power : AC 110V/60Hz	Note : MODE 2:REC

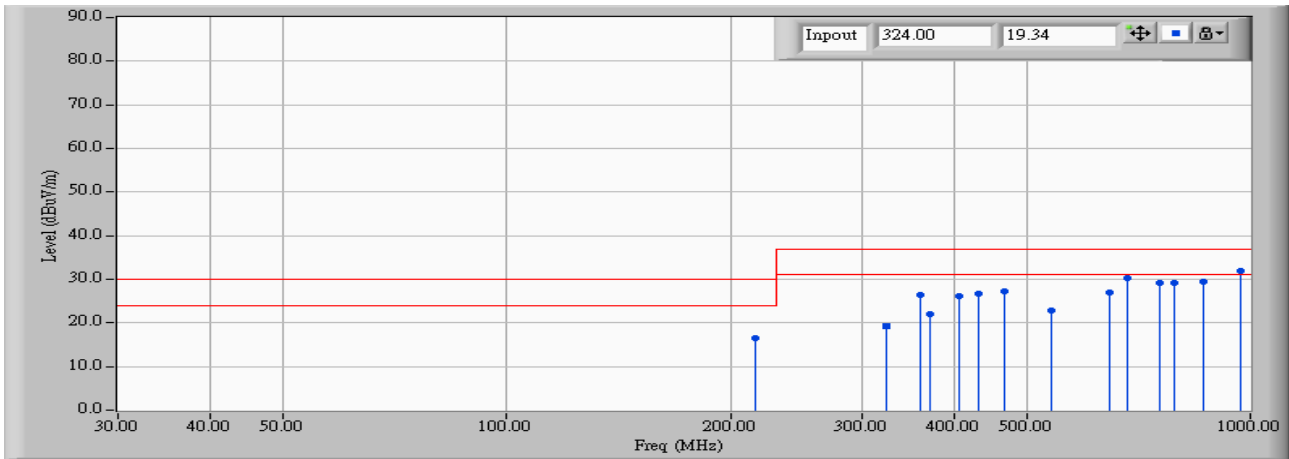

	Frequency (MHz)	Correct Factor (dB)	Reading Level (dBuV)	Measure Level (dBuV/m)	Margin (dB)	Limit (dBuV/m)	Detector Type	Ant Pos (cm)	Table Pos (deg)
1	216.000	12.493	4.060	16.553	-13.447	30.000	QUASIPeAK	400.000	106.000
2	324.000	15.260	4.080	19.340	-17.660	37.000	QUASIPeAK	300.000	-87.000
3	360.000	16.409	10.060	26.469	-10.531	37.000	QUASIPeAK	300.000	-87.000
4	371.250	15.873	6.040	21.913	-15.087	37.000	QUASIPeAK	300.000	-85.000
5	405.000	18.578	7.490	26.068	-10.932	37.000	QUASIPeAK	270.000	60.000
6	432.000	19.750	6.920	26.670	-10.330	37.000	QUASIPeAK	270.000	192.000
7	468.000	19.050	8.180	27.230	-9.770	37.000	QUASIPeAK	270.000	60.000
8	540.000	20.169	2.580	22.749	-14.251	37.000	QUASIPeAK	230.000	-56.000
9	648.000	20.552	6.320	26.872	-10.128	37.000	QUASIPeAK	180.000	123.000
10	684.000	20.565	9.670	30.235	-6.765	37.000	QUASIPeAK	180.000	93.000
11	756.000	22.921	6.340	29.261	-7.739	37.000	QUASIPeAK	130.000	200.000
12	792.000	21.861	7.210	29.071	-7.929	37.000	QUASIPeAK	130.000	95.000
13	864.000	23.011	6.380	29.391	-7.609	37.000	QUASIPeAK	130.000	-96.000
14	* 972.000	26.214	5.770	31.984	-5.016	37.000	QUASIPeAK	100.000	-123.000

Note:

1. All Readings below 1GHz are Quasi-Peak, above are performed with peak and/or average measurements as necessary.
2. " * ", means this data is the worst emission level.
3. Measurement Level = Reading Level + Correct Factor.

Site : cb3	Time : 2006/04/03 - 13:06
Limit : FCC_B_(Above_1G)_3M_PK	Margin : 6
EUT : DSC-S500	Probe : RF_1G-18G(2005-3) - HORIZONTAL
Power : AC 120V/60Hz	Note : MODE 2:REC

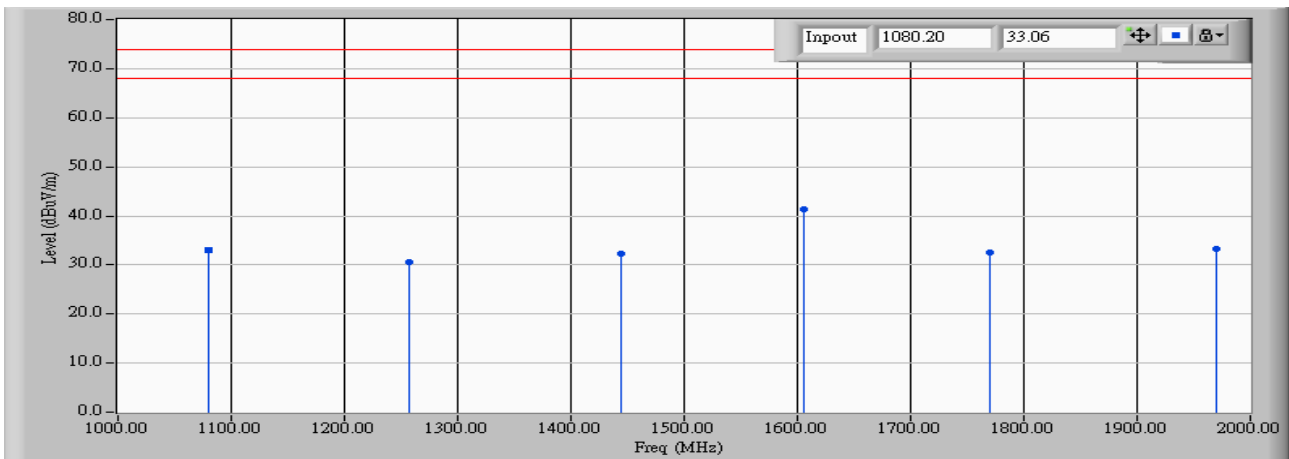

	Frequency (MHz)	Correct Factor (dB)	Reading Level (dBuV)	Measure Level (dBuV/m)	Margin (dB)	Limit (dBuV/m)	Detector Type	Ant Pos (cm)	Table Pos (deg)
1	1080.200	-9.877	42.940	33.064	-40.936	74.000	PEAK	0.000	0.000
2	1256.610	-7.353	37.950	30.597	-43.403	74.000	PEAK	0.000	0.000
3	1444.010	-7.030	39.400	32.370	-41.630	74.000	PEAK	0.000	0.000
4	* 1606.240	-6.853	48.250	41.397	-32.603	74.000	PEAK	0.000	0.000
5	1770.200	-6.310	38.750	32.441	-41.559	74.000	PEAK	0.000	0.000
6	1970.520	-5.100	38.490	33.390	-40.610	74.000	PEAK	0.000	0.000

Note:

1. All Readings below 1GHz are Quasi-Peak, above are performed with peak and/or average measurements as necessary.
2. " * ", means this data is the worst emission level.
3. Measurement Level = Reading Level + Correct Factor.

Site : Quietek SH-Site2	Time : 2006/04/04 - 13:42
Limit : CISPR_B_10M_QP	Margin : 6
EUT : DSC-S500	Probe : PRO 05-10-04 ST2 - VERTICAL
Power : AC 110V/60Hz	Note : MODE 2:REC

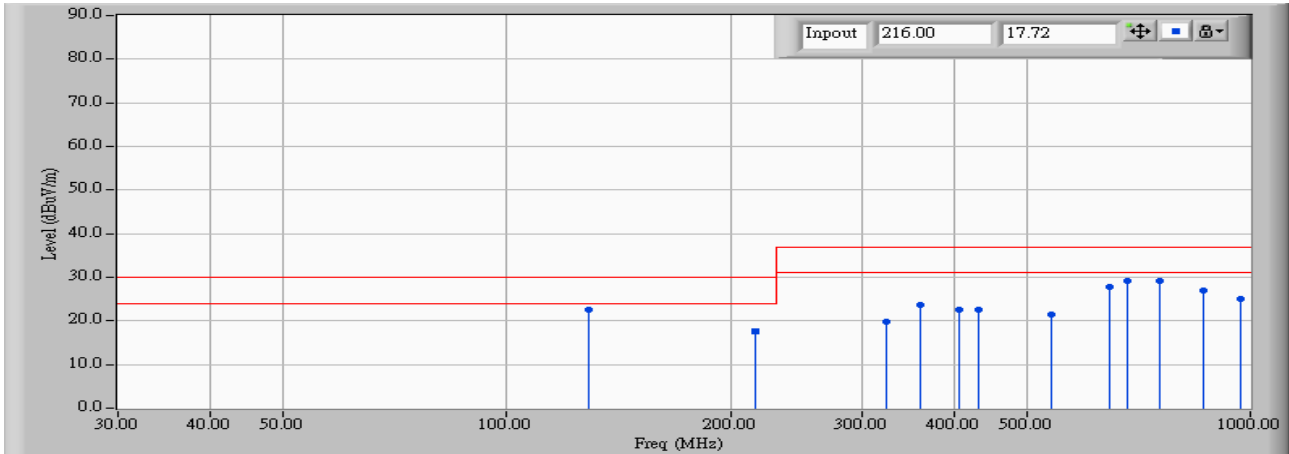

		Frequency (MHz)	Correct Factor (dB)	Reading Level (dBuV)	Measure Level (dBuV/m)	Margin (dB)	Limit (dBuV/m)	Detector Type	Ant Pos (cm)	Table Pos (deg)
1	*	128.675	14.556	8.050	22.606	-7.394	30.000	QUASPEAK	100.000	9.000
2		216.000	12.161	5.560	17.721	-12.279	30.000	QUASPEAK	100.000	61.000
3		324.000	15.596	4.220	19.816	-17.184	37.000	QUASPEAK	100.000	-65.000
4		360.000	18.224	5.530	23.754	-13.246	37.000	QUASPEAK	100.000	83.000
5		405.000	15.848	6.850	22.698	-14.302	37.000	QUASPEAK	100.000	-86.000
6		432.000	18.412	4.070	22.482	-14.518	37.000	QUASPEAK	100.000	-7.000
7		540.000	19.628	1.920	21.548	-15.452	37.000	QUASPEAK	300.000	85.000
8		648.000	20.239	7.650	27.889	-9.111	37.000	QUASPEAK	270.000	45.000
9		684.000	20.341	8.810	29.151	-7.849	37.000	QUASPEAK	270.000	45.000
10		756.000	21.738	7.430	29.168	-7.832	37.000	QUASPEAK	230.000	-57.000
11		864.000	21.775	5.310	27.085	-9.915	37.000	QUASPEAK	230.000	-70.000
12		972.000	24.627	0.380	25.007	-11.993	37.000	QUASPEAK	180.000	63.000

Note:

1. All Readings below 1GHz are Quasi-Peak, above are performed with peak and/or average measurements as necessary.
2. " * ", means this data is the worst emission level.
3. Measurement Level = Reading Level + Correct Factor.

Site : cb3	Time : 2006/04/03 - 13:03
Limit : FCC_B_(Above_1G)_3M_PK	Margin : 6
EUT : DSC-S500	Probe : RF_1G-18G(2005-3) - VERTICAL
Power : AC 120V/60Hz	Note : MODE 2:REC

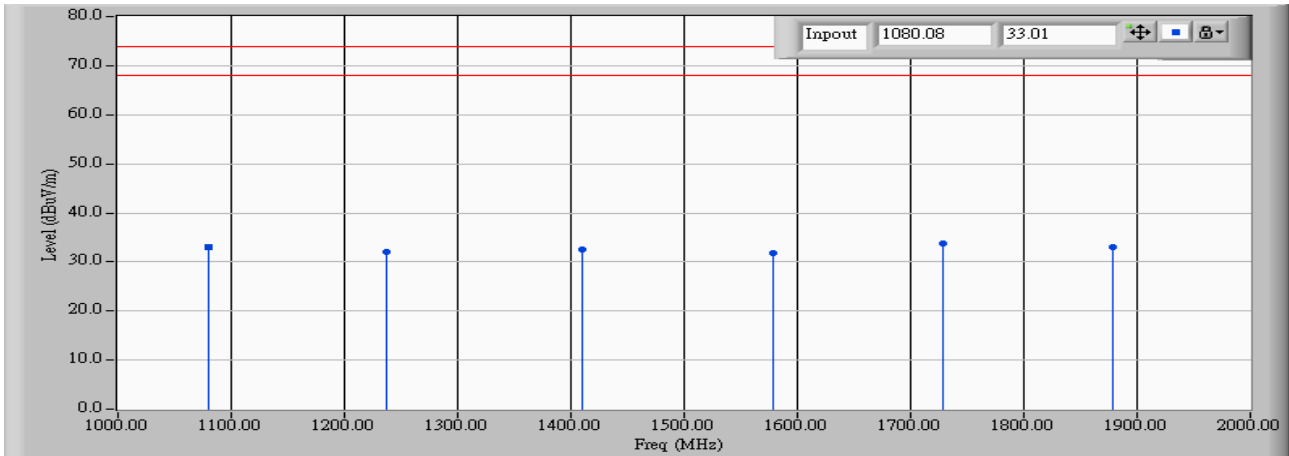

	Frequency (MHz)	Correct Factor (dB)	Reading Level (dBuV)	Measure Level (dBuV/m)	Margin (dB)	Limit (dBuV/m)	Detector Type	Ant Pos (cm)	Table Pos (deg)
1	1080.080	-9.079	42.090	33.012	-40.988	74.000	PEAK	0.000	0.000
2	1236.600	-6.590	38.550	31.961	-42.039	74.000	PEAK	0.000	0.000
3	1410.100	-6.260	38.880	32.619	-41.381	74.000	PEAK	0.000	0.000
4	1578.800	-6.098	37.970	31.872	-42.128	74.000	PEAK	0.000	0.000
5	* 1728.210	-5.649	39.320	33.672	-40.328	74.000	PEAK	0.000	0.000
6	1878.600	-5.823	38.900	33.077	-40.923	74.000	PEAK	0.000	0.000

Note:

1. All Readings below 1GHz are Quasi-Peak, above are performed with peak and/or average measurements as necessary.
2. " * ", means this data is the worst emission level.
3. Measurement Level = Reading Level + Correct Factor.

4.6. Test Photograph

Test Mode : Mode 2:REC

Description : Front View of Radiated Emission Test Setup



Test Mode : Mode 2:REC

Description : Back View of Radiated Emission Test Setup



Test Mode : Mode 2:REC

Description : Front View of Radiated Emission Test Setup (Horn)

