



EMC Technologies Pty Ltd

ABN 82 057 105 549
Unit 3/87 Station Road
Seven Hills NSW 2147 Australia

Telephone +61 2 9624 2777
Facsimile +61 2 9838 4050
Email syd@emctech.com.au
www.emctech.com.au

**APPENDIX I
OF
TEST REPORT T71003_F**

LABELLING - LOCATION

FCC ID: TVN-MSTRP
Manufacturer: Magellan Technology Pty Limited
Test Sample: PJM Stack Tag Tunnel Reader
Model: MSTRP-5050
Serial No: Production Prototype

Date: 25th October 2007

Melbourne

176 Harrick Road
Keilor Park, Vic 3042
Tel: +61 3 9365 1000
Fax: +61 3 9331 7455

Sydney

Unit 3/87 Station Road
Seven Hills NSW 2147
Tel: +61 2 9624 2777
Fax: +61 2 9838 4050

Brisbane

1/15 Success Street
Acacia Ridge Qld 4110
Tel: +61 7 3875 2455
Fax: +61 7 3875 2466

Auckland (NZ)

47 MacKelvie Street
Grey Lynn Auckland
Tel: +64 9 360 0862
Fax: +64 9 360 0861

REVISIONS				
ECN#	REV.	DESCRIPTION	DATE	APPROVED
N/A	1	Production Release	27/08/07	HZ

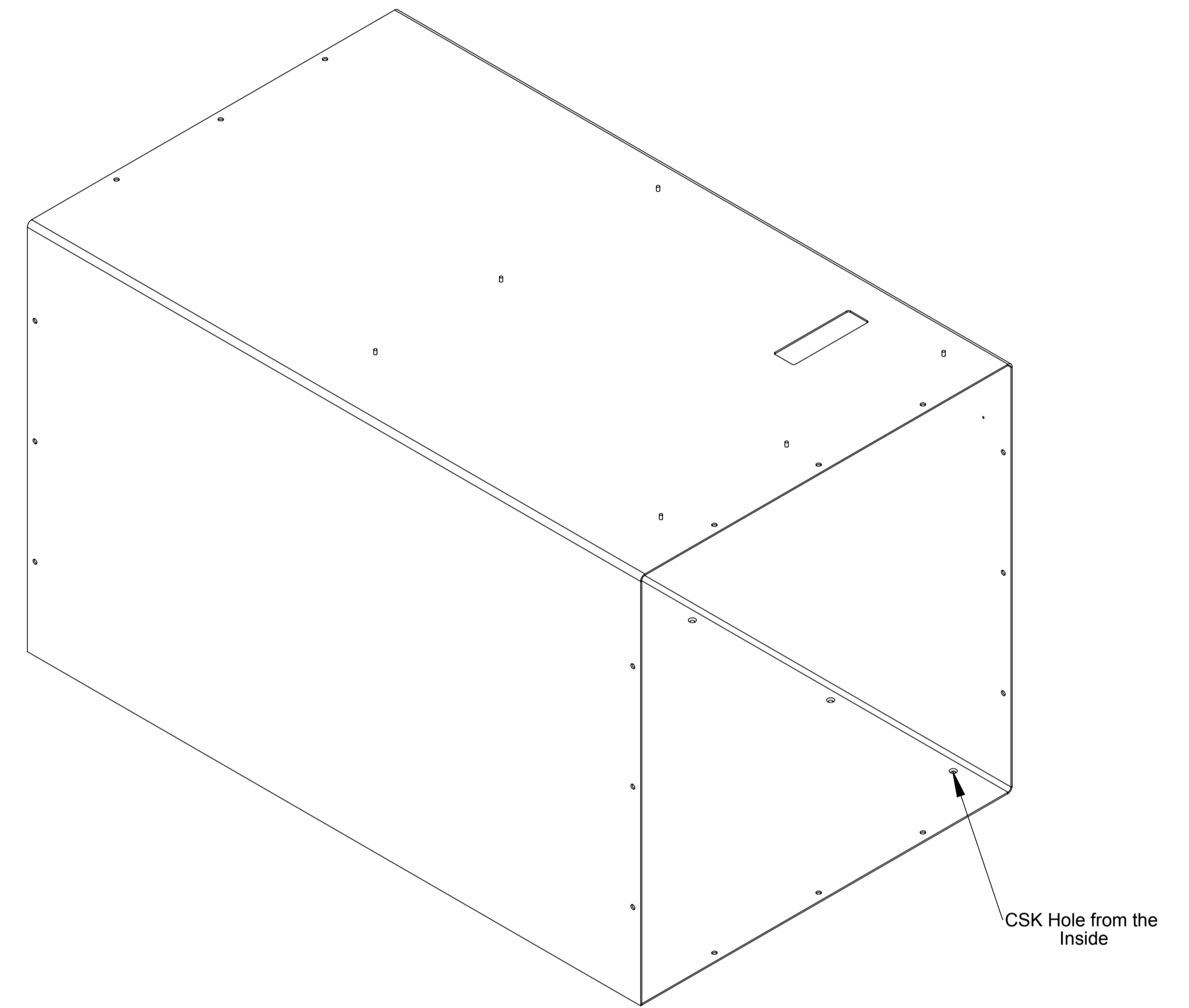
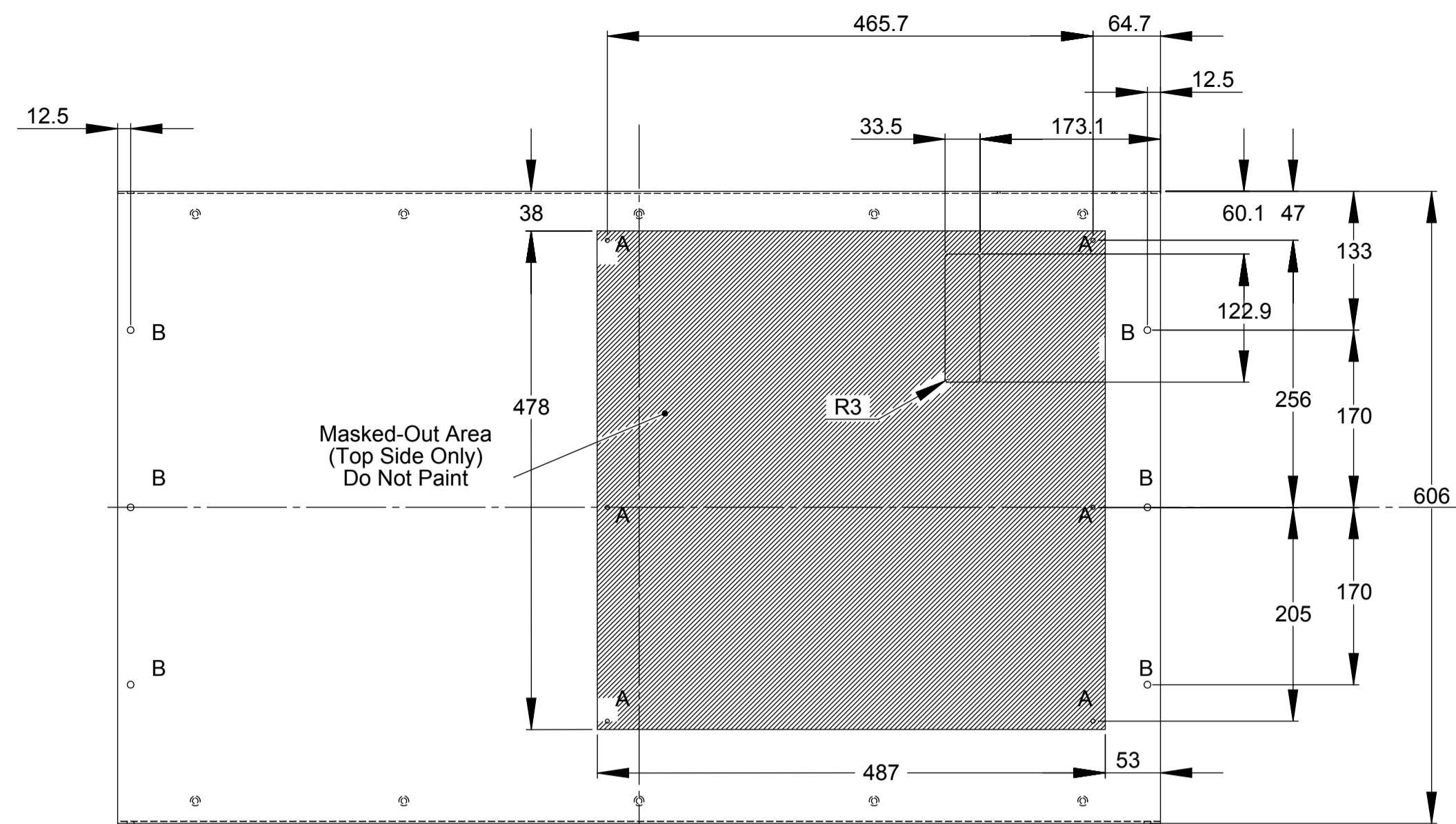

Material: 2mm Aluminium
 Finish: Powder Coated
 Colour: Dulux Stromboli Ref. No. 84655
 (see masked-out area)

FINISHED PART TO BE FREE FROM
 BURRS AND SHARP EDGES

Tolerances: +/-0.5mm

Holes & Fasteners

A=Qty 6 M4x10mm Stud PFH-M4-10-Z
 B=Qty 24 6.5mm Hole
 C=Qty 10 M4mm CSK Hole (note CSK side)
 D=Qty 4 2.4mm Hole

SW Model P/N 049-50-797-3DP

PROPRIETARY AND CONFIDENTIAL
 THE INFORMATION CONTAINED IN THIS
 DRAWING IS THE SOLE PROPERTY OF
 MAGELLAN TECHNOLOGY PTY LIMITED.
 ANY REPRODUCTION IN PART OR AS A
 WHOLE WITHOUT THE WRITTEN PERMISSION
 OF MAGELLAN TECHNOLOGY IS PROHIBITED.

Magellan Related Part Number(s)		DO NOT SCALE DRAWING	Version: 1
Bill of Material (BOM)		MAGELLAN TECHNOLOGY TITLE: Skin STRP-5050 MK5	
Assembly (ASY)			
3D Part Model (3DP)	049-50-797-3DP		
Hardware Part (HAW)	049-50-797-HAW		
Other(s)			
DRAWN	H Zollinger	SIGNATURE	DATE
CHKD			270807
APPVD			
MFG			
DWG NO.		049-50-797-3DD	A1
SCALE: 1:5		SHEET 1 OF 1	

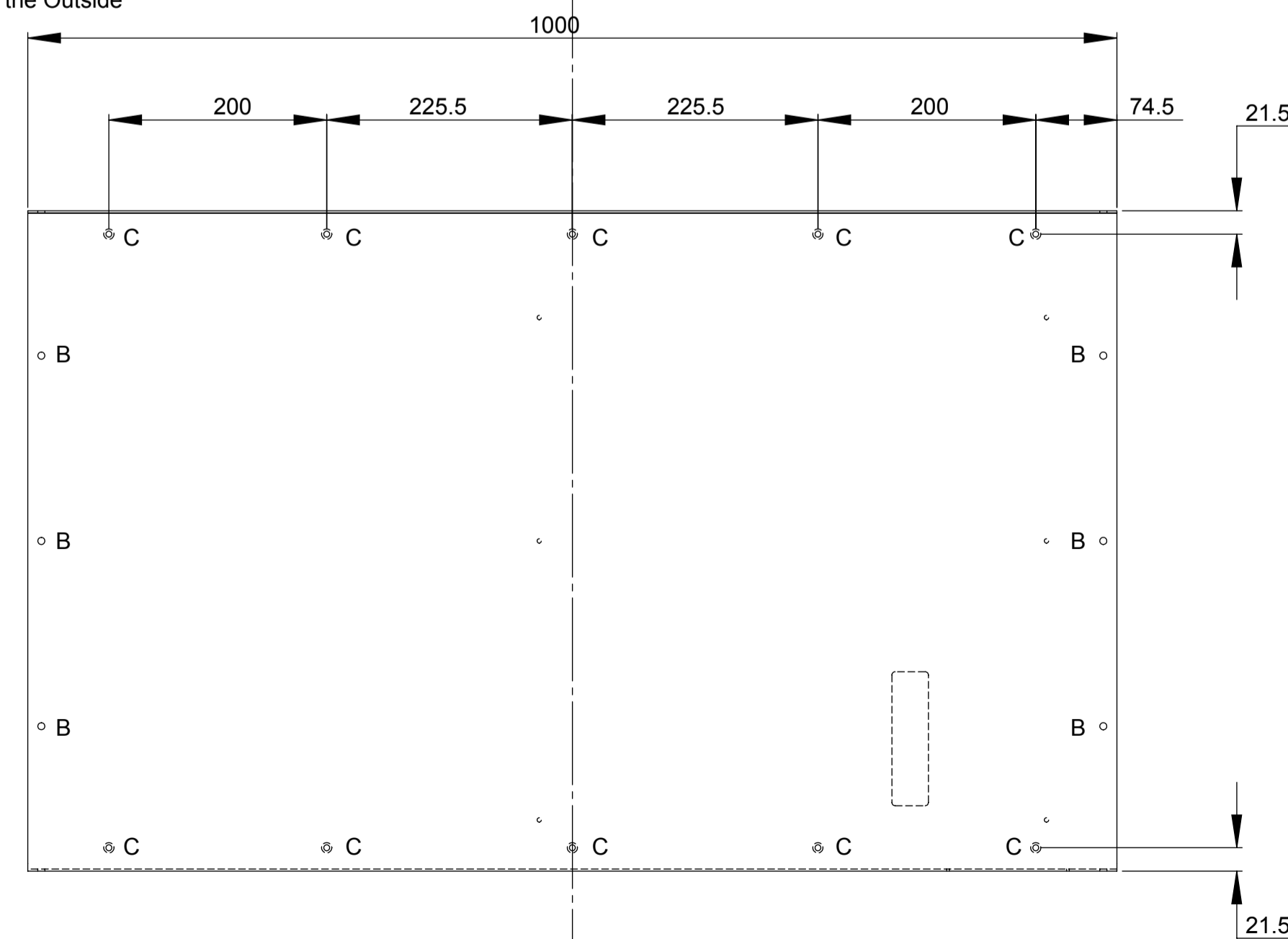
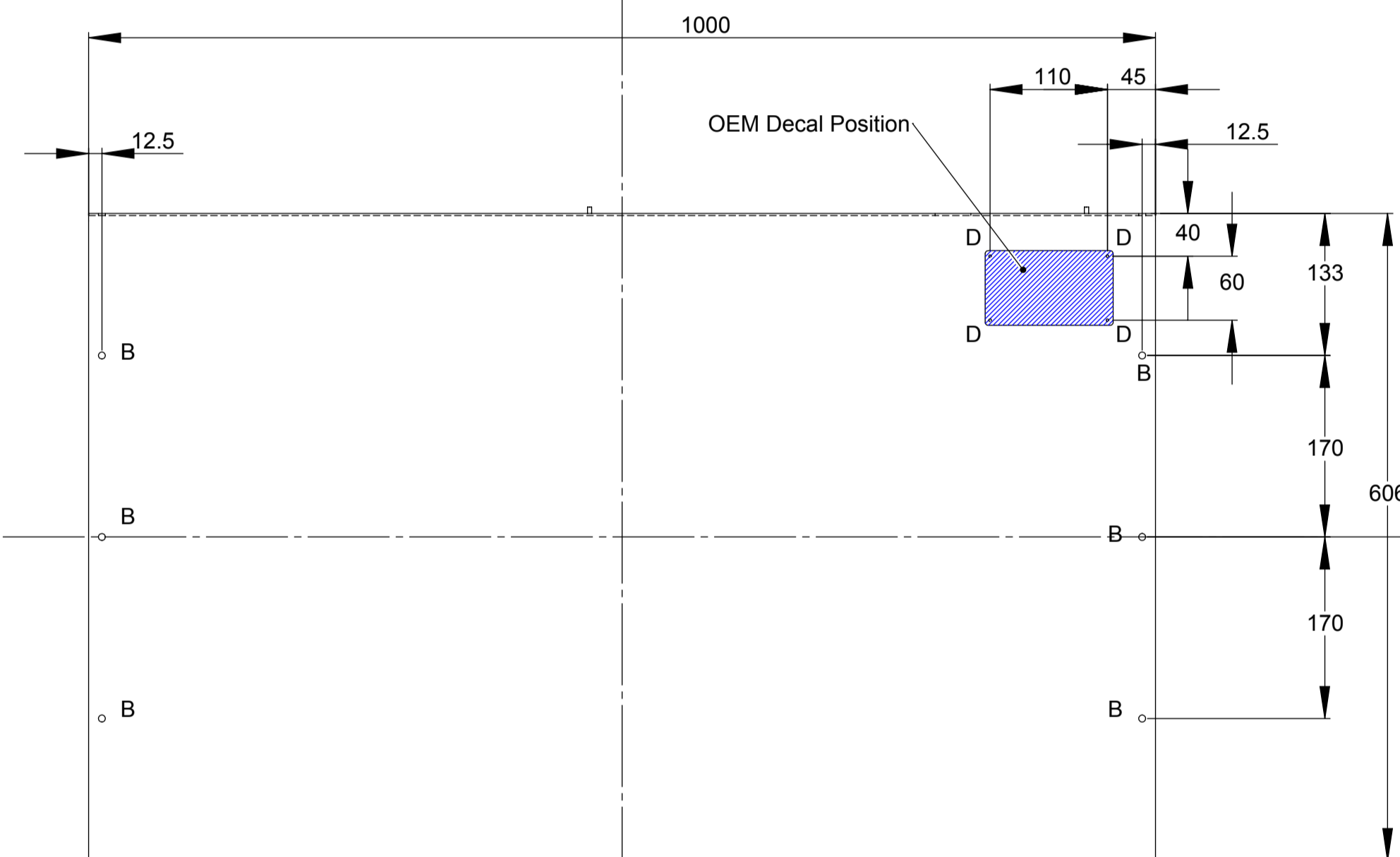
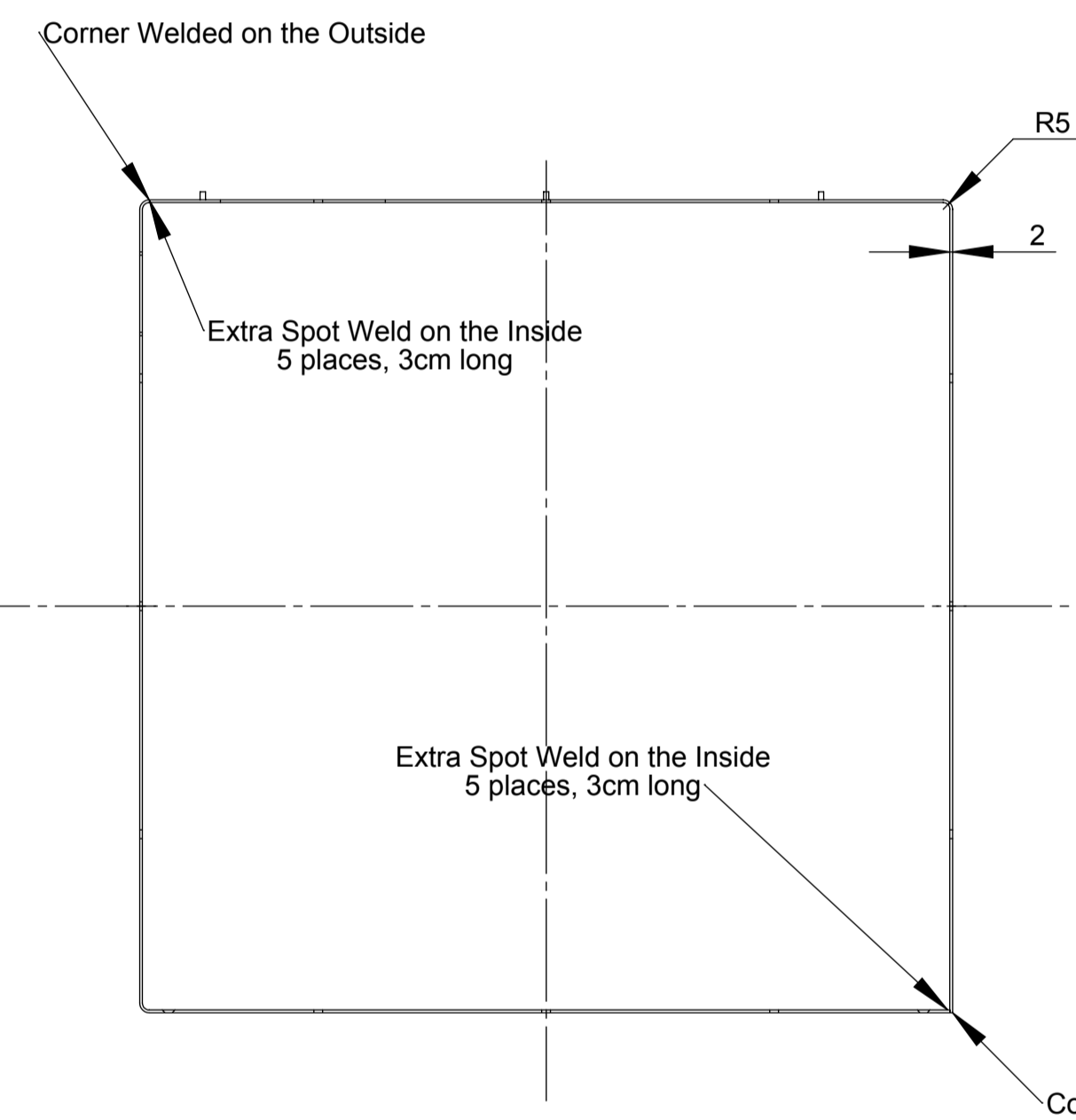

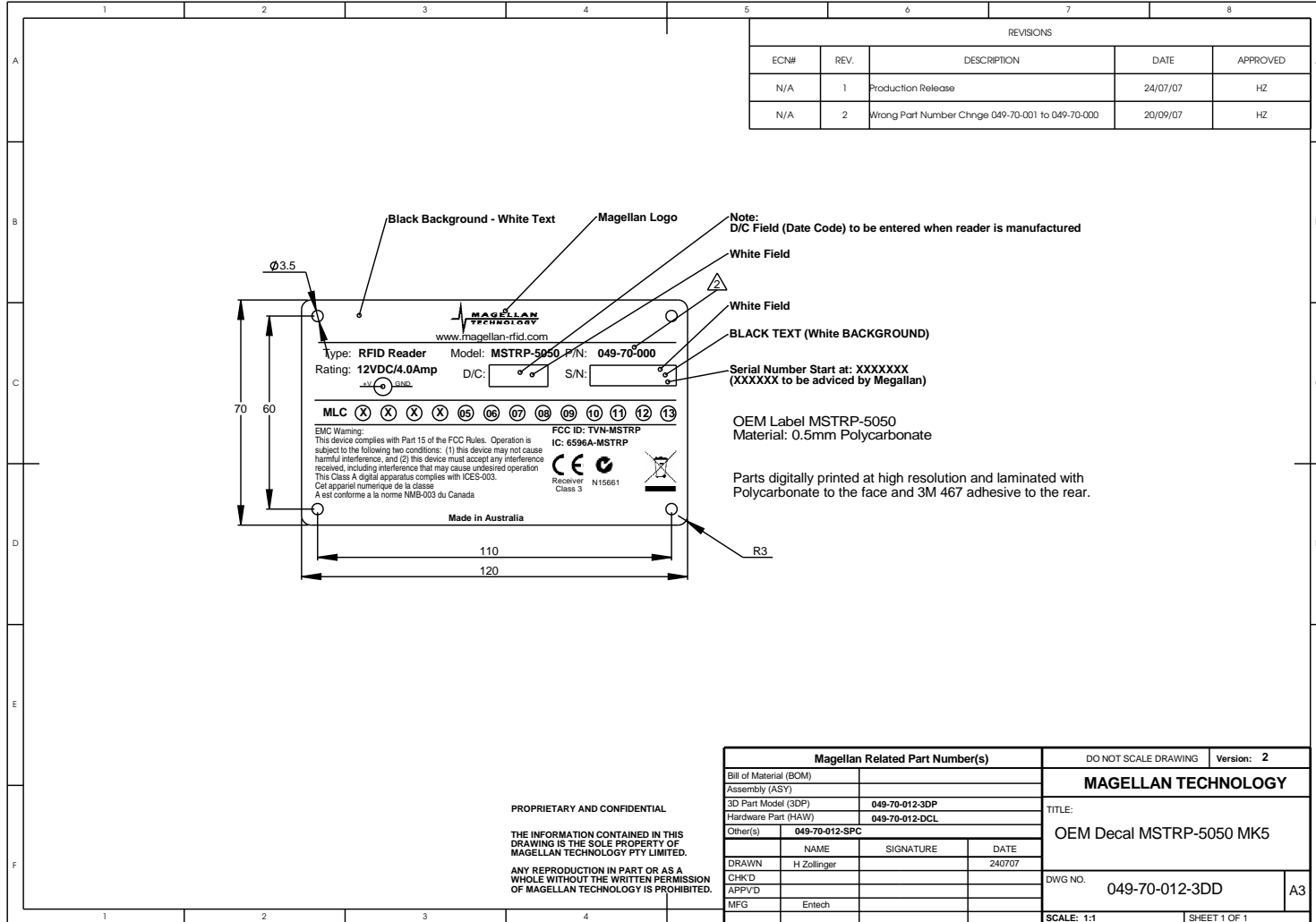

PROPRIETARY AND CONFIDENTIAL

THE INFORMATION CONTAINED IN THIS DRAWING IS THE SOLE PROPERTY OF MAGELLAN TECHNOLOGY PTY LIMITED.

ANY REPRODUCTION IN PART OR AS A WHOLE WITHOUT THE WRITTEN PERMISSION OF MAGELLAN TECHNOLOGY IS PROHIBITED.

Magellan Related Part Number(s)		DO NOT SCALE DRAWING	Version: 2
Bill of Material (BOM)		MAGELLAN TECHNOLOGY	
Assembly (ASY)			
3D Part Model (3DP)			
Hardware Part (HAW)			
Other(s)		TITLE:	
049-70-012-SPC		OEM Decal MSTRP-5050 MK5	
NAME	SIGNATURE	DATE	DWG NO. 049-70-012-3DD
DRAWN	H Zollinger	240707	
CHKD			
APPVD			
MFG	Entech		
SCALE: 1:1		SHEET 1 OF 1	

A3