

客戶名稱 : 環鴻  
CUSTOMER

Documnet No.: ENS000162400

Approval Sheet Rev.: A4

Spec. Rev. : P8

# 承認書

## APPROVAL SHEET

產品品名/Product Model No. : WA-M-LALBLCLE-12-001

客戶料號/Customer No. : 46-500534-01

案名/Model Name. : USI FAP-U231G

發行日期/ Issue Date : 2023/02/15

承認日期/ Approved Date : \_\_\_\_\_

Approved by customer: (signing or stamping here)



佳邦科技股份有限公司  
INPAQ TECHNOLOGY CO., LTD.

■ 350 苗栗縣竹南鎮公義里11鄰科義街11號    □ 428 台中市大雅區科雅路27號4樓

電話 : 037-585-555

電話 : 04-2560-6555

傳真 : 037-585-511

傳真 : 04-2560-5151

No. 11, Ke-Yi St., Chunan, Miaoli 350,  
Taiwan, R.O.C.

4F, No. 27, Keya Road, Daya Dist., Taichung City  
428, Taiwan, R.O.C.

Tel. : +886-37-585-555

Tel. : +886-4-25606555

Fax : +886-37-585-511

Fax : +886-4-25605151

# Embedded Multi-Band Antenna for WA-M-LALBLCLE-12-001

## 1. Explanation of part number :

<b>WA</b>	<b>M</b>	<b>LALBLCLE</b>	<b>12</b>	<b>001</b>
(1)	(2)	(3)	(4)	(5)

- (1) Product type : Wireless Antenna
- (2) Material : Metal
- (3) Frequency : 2400~2500/5150-5850/5850-7125 MHz
- (4) Coaxial Cable Type : Black/White/Grey/Blue/Red Cable
- (5) Suffix : 001

※Antenna type : PIFA

## 2. Electrical Specification :

The specifications were specially defined for **FAP-U231G** model Antenna, and all characteristics were measured under the model's handset testing jig.

### 2-1. Frequency Band :

Frequency	D1-D4 2400-2500/5150-5850 MHz
	5G 5100-5900 MHz
	6G 5800-7500 MHz
	BT 2400-2500 MHz

UNLESS OTHER SPECIFIED TOLERANCES ON : X=N/A      X.X=N/A      X.XX=N/A ANGLES=N/A      HOLEDIA=N/A			<b>INPAQ TECHNOLOGY CO., LTD.</b>
SCALE : N/A      UNIT : mm	THIS DRAWINGS AND SPECIFICATIONS ARE THE PROPERTY OF INPAQ TECHNOLOGY CO.,LTD.AND SHALL NOT BE REPRODUCED OR USED AS THE BASIS FOR THE MANUFACTURE OR SALE OF APPARATUS OR DEVICES WITHOUT PERMISSION		
DRAWN BY : 黃建棠	CHECKED BY : 鄭榮謀		
DESIGNED BY : 彭少君	APPROVED BY : 謝立庭		
TITLE : Embedded Multi-Band Antenna for WA-M-LALBLCLE-12-001		DOCUMENT NO.	ENS000162400
		SPEC REV. <b>P8</b>	

### 3. Antenna Drawing :

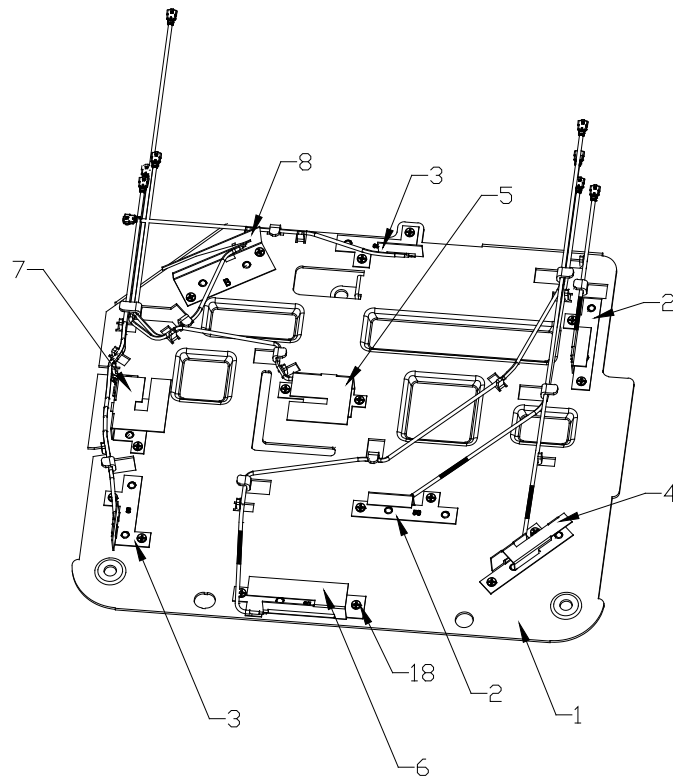
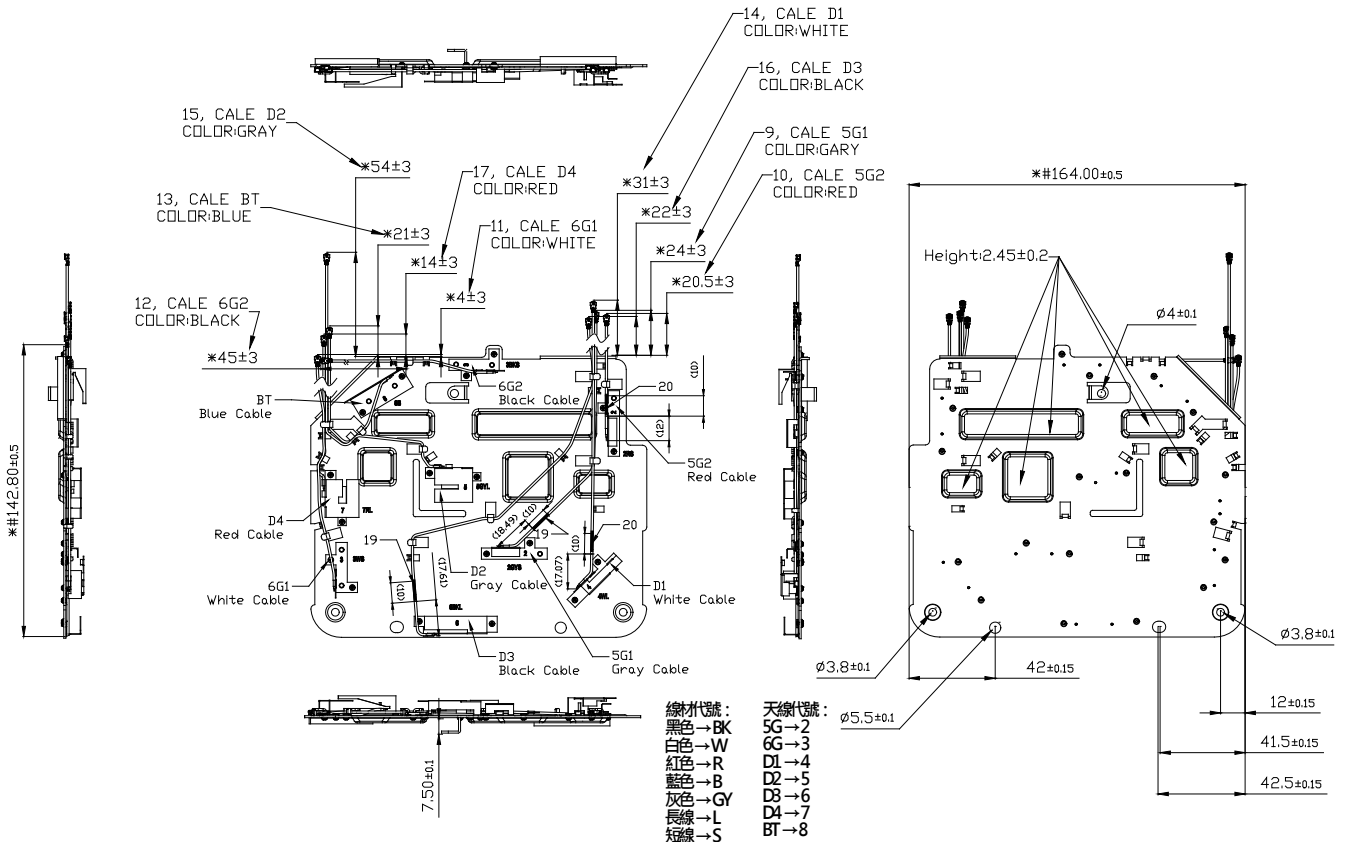

UNLESS OTHER SPECIFIED TOLERANCES ON : X=N/A      X.X=N/A      X.XX=N/A ANGLES=N/A      HOLEDIA=N/A		 <b>INPAQ TECHNOLOGY CO., LTD.</b>
SCALE : N/A	UNIT : mm	
DRAWN BY : 黃建棠	CHECKED BY : 鄭榮謀	THIS DRAWINGS AND SPECIFICATIONS ARE THE PROPERTY OF INPAQ TECHNOLOGY CO.,LTD.AND SHALL NOT BE REPRODUCED OR USED AS THE BASIS FOR THE MANUFACTURE OR SALE OF APPARATUS OR DEVICES WITHOUT PERMISSION
DESIGNED BY : 彭少君	APPROVED BY : 謝立庭	
TITLE : Embedded Multi-Band Antenna for WA-M-LALBLCLE-12-001		DOCUMENT NO. <b>ENS000162400</b>
		SPEC REV. <b>P8</b>

## NOTE:

1. 外觀標準: 需完整無破損, 不可有變形、髒污、毛邊、翹曲、裂縫、褶疊等情形。  
Appearance standard : They must be complete. It means those must not have the deformations, dirt, burrs, warps, cracks, folds, etc.
2. 工程圖上"\*"號為重點尺寸標註指示  
Mark "\*" are the key dimensions.
3. 工程圖上"#號為Cpk量測尺寸標註指示  
Mark "# are CPK dimensions.
4. □QC&FQC 只需量測重點尺寸&CPK  
CPK&KEY dimensions for □QC&FQC.

REV.P2

ITEM	DESCRIPTION	MATERIAL SPECIFICATION	QUANTITY	UNIT
1	PLATE/AL5052	T1.0mm,L164*W142.8mm	1	PCS
2	METAL 5G/SUS430 PLATING NICKEL	T0.3mm,32.1*10.5*6mm	2	PCS
3	METAL 6G/SUS430 PLATING NICKEL	T0.3mm,27.1*15.5*7.6mm	2	PCS
4	METAL D1/SUS430 PLATING NICKEL	T0.3mm,32.1*11*8.8mm	1	PCS
5	METAL D2/SUS430 PLATING NICKEL	T0.3mm,27*18.5*7.5mm	1	PCS
6	METAL D3/SUS430 PLATING NICKEL	T0.3mm,40.5*9.8*7.3mm	1	PCS
7	METAL D4/SUS430 PLATING NICKEL	T0.3mm,27*18*7.5mm	1	PCS
8	METAL BT/SUS430 PLATING NICKEL	T0.3mm,32.7*10.75*9.8mm	1	PCS
9	CABLE 5G1	OD 1.13mm LLS GRAY IPEX MHF I-PEX Equivalent(compatible)	1	PCS
10	CABLE 5G2	OD 1.13mm LLS RED IPEX MHF I-PEX Equivalent(compatible)	1	PCS
11	CABLE 6G1	OD 1.13mm LLS WHITE IPEX MHF I-PEX Equivalent(compatible)	1	PCS
12	CABLE 6G2	OD 1.13mm LLS BLACK IPEX MHF I-PEX Equivalent(compatible)	1	PCS
13	CABLE BT	OD 1.13mm LLS BLUE IPEX MHF I-PEX Equivalent(compatible)	1	PCS

UNLESS OTHER SPECIFIED TOLERANCES ON :  
 X=N/A      X.X=N/A      X.XX=N/A  
 ANGLES=N/A      HOLEDIA=N/A



INPAQ TECHNOLOGY CO., LTD.

SCALE : N/A

UNIT : mm

DRAWN BY : 黃建棠

CHECKED BY : 鄭榮謀

DESIGNED BY : 彭少君

APPROVED BY : 謝立庭

THIS DRAWINGS AND SPECIFICATIONS ARE THE PROPERTY OF  
 INPAQ TECHNOLOGY CO.,LTD.AND SHALL NOT BE REPRODUCED  
 OR USED AS THE BASIS FOR THE MANUFACTURE OR SALE OF  
 APPARATUS OR DEVICES WITHOUT PERMISSION

TITLE : Embedded Multi-Band Antenna for  
 WA-M-LALBLCLE-12-001

DOCUMENT  
 NO.

ENS000162400

SPEC REV.  
 P8

14	CABLE D1	OD 1.13mm LLS WHITE IPEX MHF I-PEX Equivalent(compatible)	1	PCS
15	CABLE D2	OD 1.13mm LLS GRAY IPEX MHF I-PEX Equivalent(compatible)	1	PCS
16	CABLE D3	OD 1.13mm LLS BLACK IPEX MHF I-PEX Equivalent(compatible)	1	PCS
17	CABLE D4	OD 1.13mm LLS RED IPEX MHF I-PEX Equivalent(compatible)	1	PCS
18	SCREWS	SUS304/M2	18	PCS
19	Heat-Shrinkable Tube	OD1.5x10mm, White	2	PCS
20	Heat-Shrinkable Tube	OD1.5x10mm, Black	2	PCS

UNLESS OTHER SPECIFIED TOLERANCES ON :  
 X = N/A      X.X = N/A      X.XX = N/A  
 ANGLES = N/A      HOLEDIA = N/A



**INPAQ TECHNOLOGY CO., LTD.**

SCALE : N/A

UNIT : mm

DRAWN BY : 黃建榮

CHECKED BY : 鄭榮謀

DESIGNED BY : 彭少君

APPROVED BY : 謝立庭

THIS DRAWINGS AND SPECIFICATIONS ARE THE PROPERTY OF  
 INPAQ TECHNOLOGY CO.,LTD.AND SHALL NOT BE REPRODUCED  
 OR USED AS THE BASIS FOR THE MANUFACTURE OR SALE OF  
 APPARATUS OR DEVICES WITHOUT PERMISSION

TITLE : Embedded Multi-Band Antenna for  
 WA-M-LALBLCLE-12-001

DOCUMENT  
 NO.

**ENS000162400**

SPEC REV.  
**P8**

# Antenna Placement & Solution

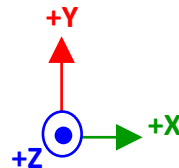
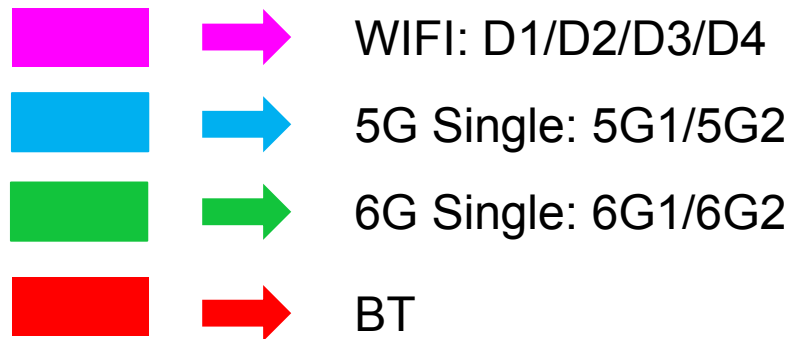
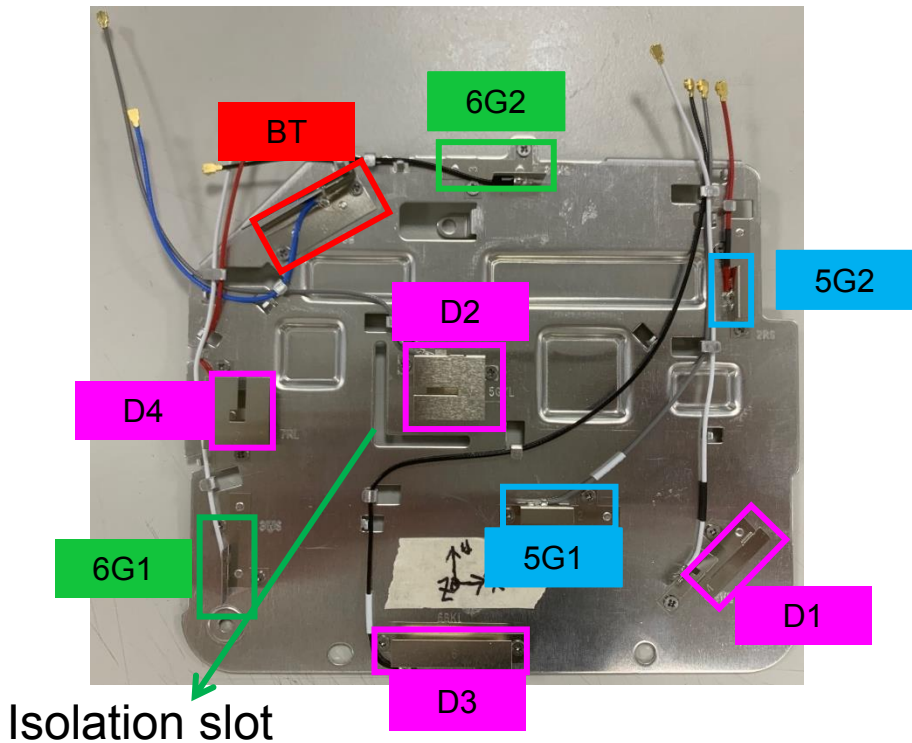

# S11 Results

## D1

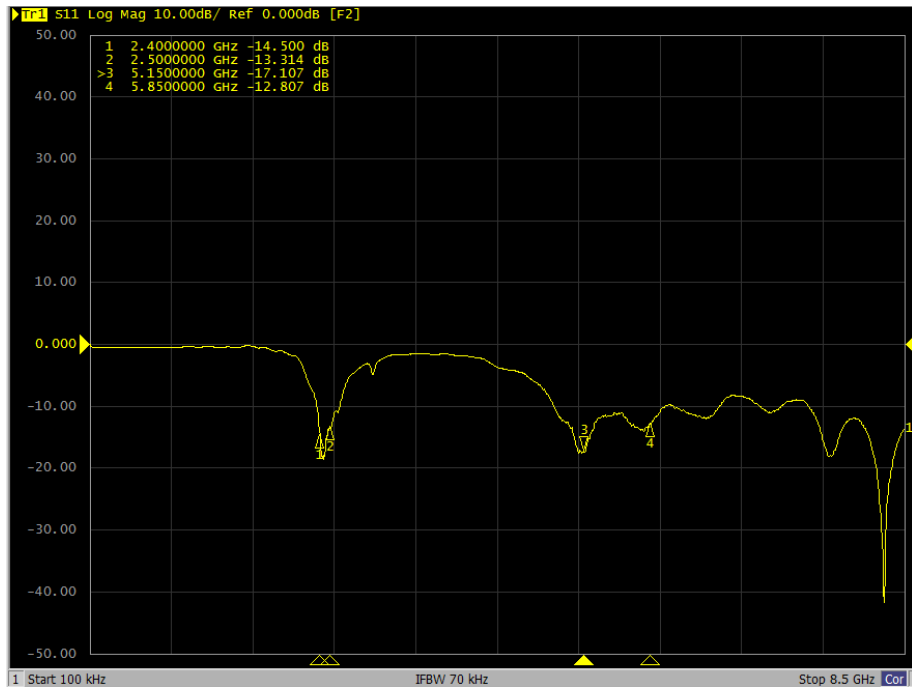

## D2

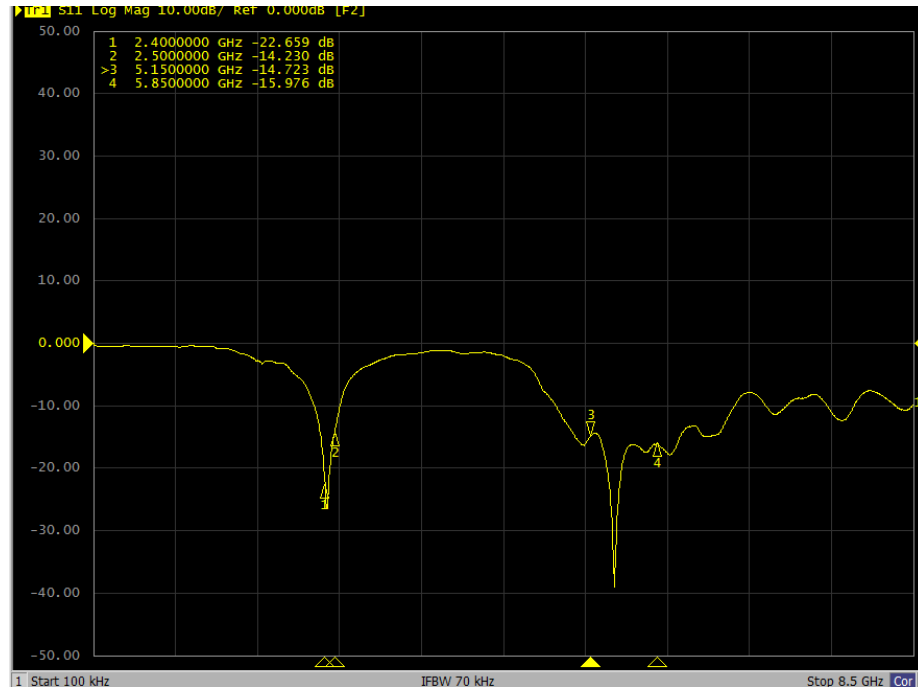

# S11 Results

## D3

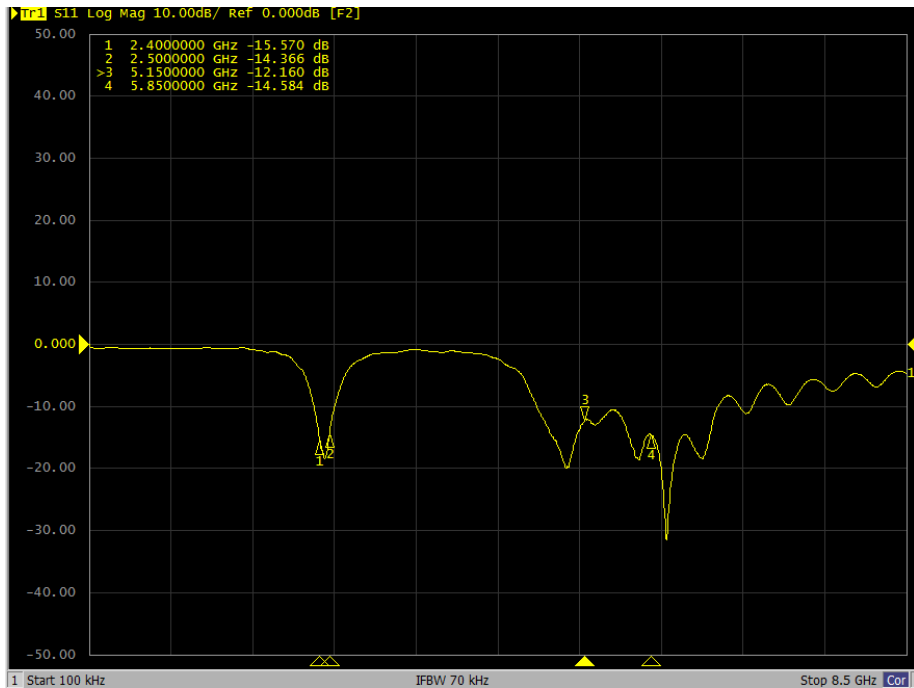

## D4

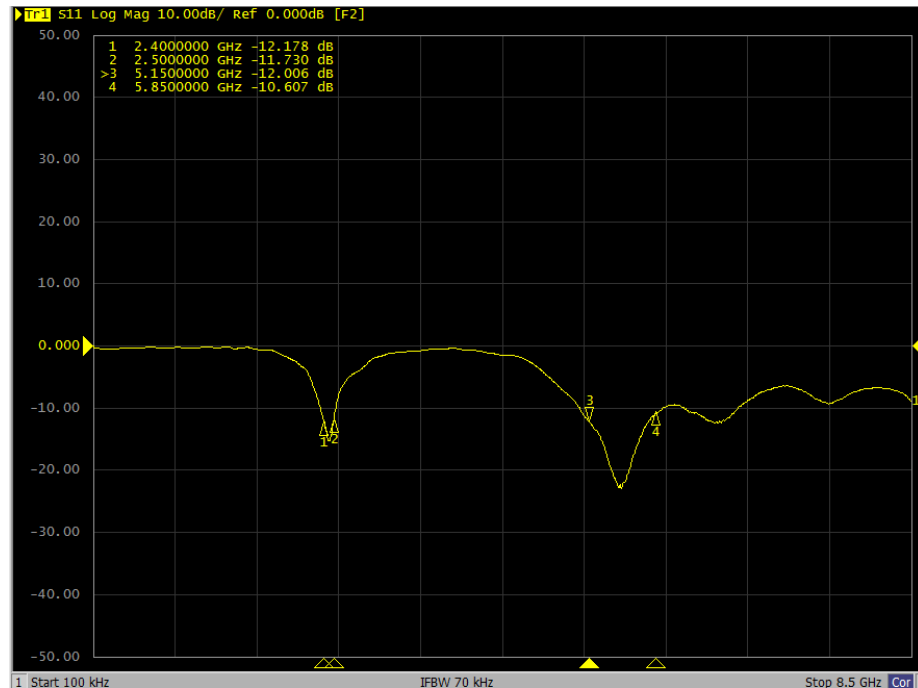



# S11 Results

## 5G1

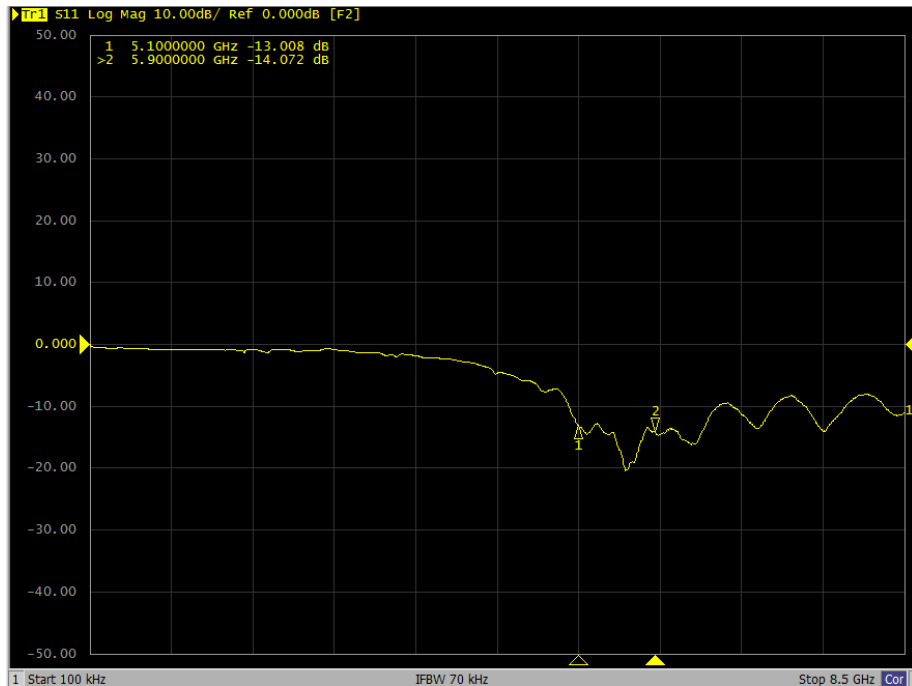

## 5G2

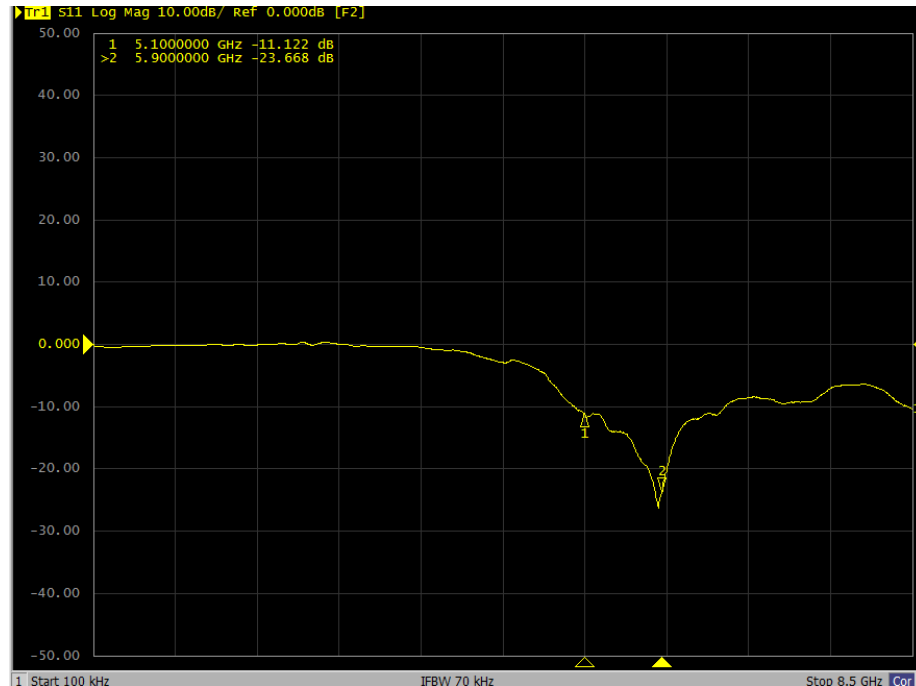

# S11 Results

## 6G1

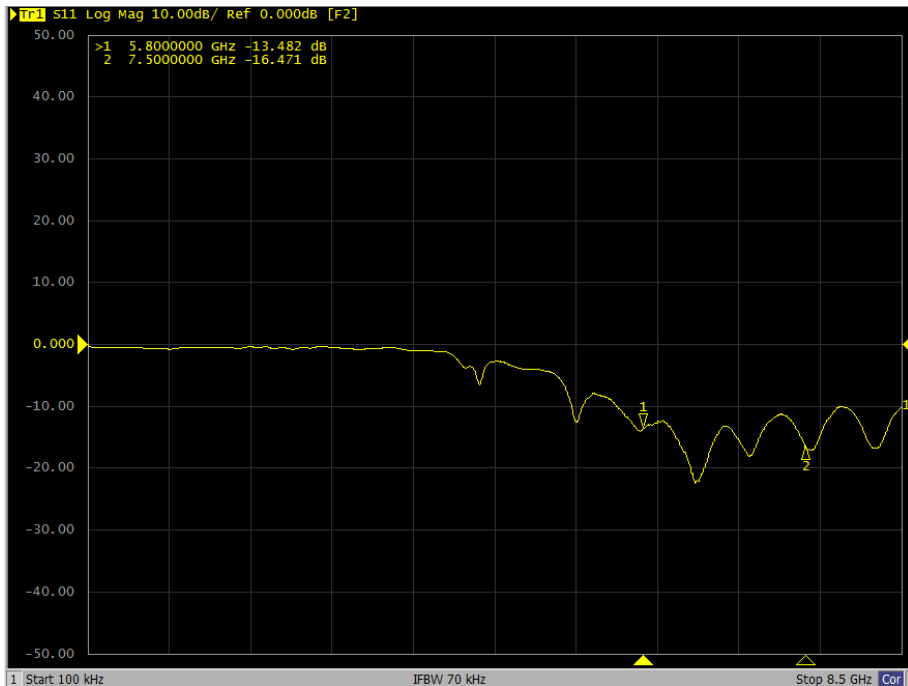

## 6G2

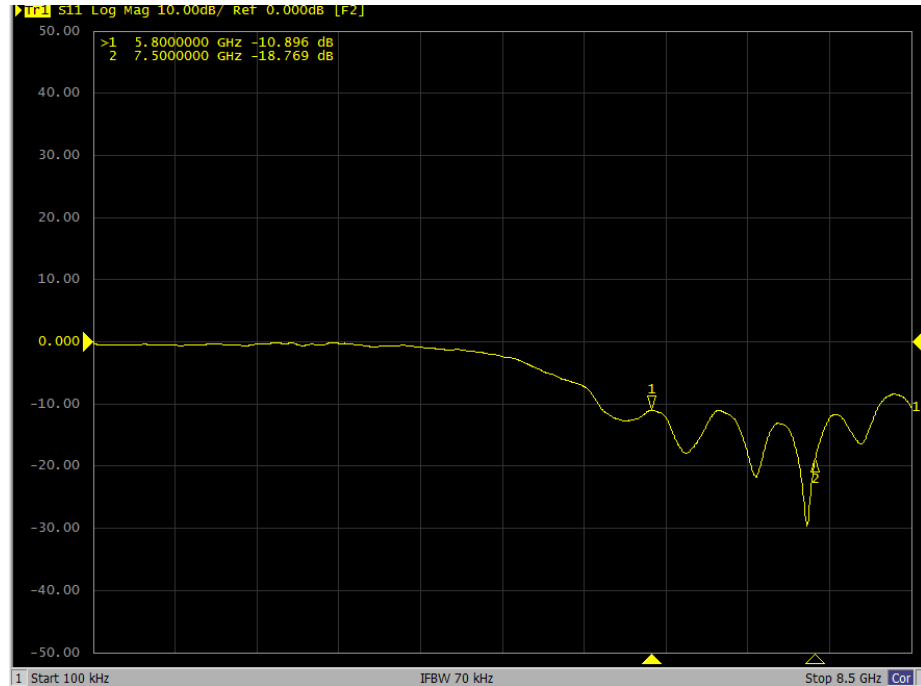

# S11 Results

BT

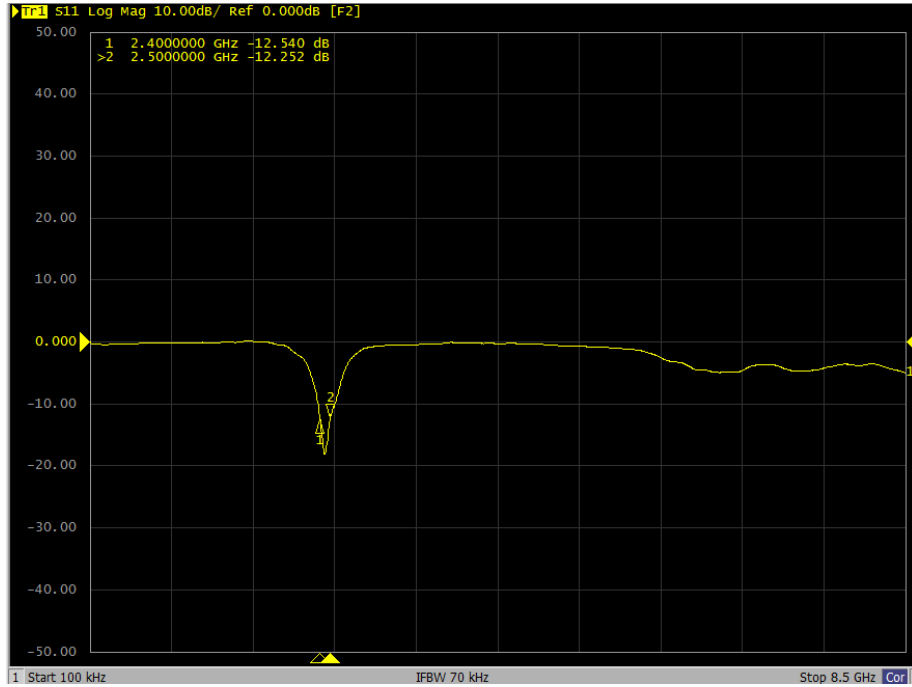

# Isolation Results

## D1-D2

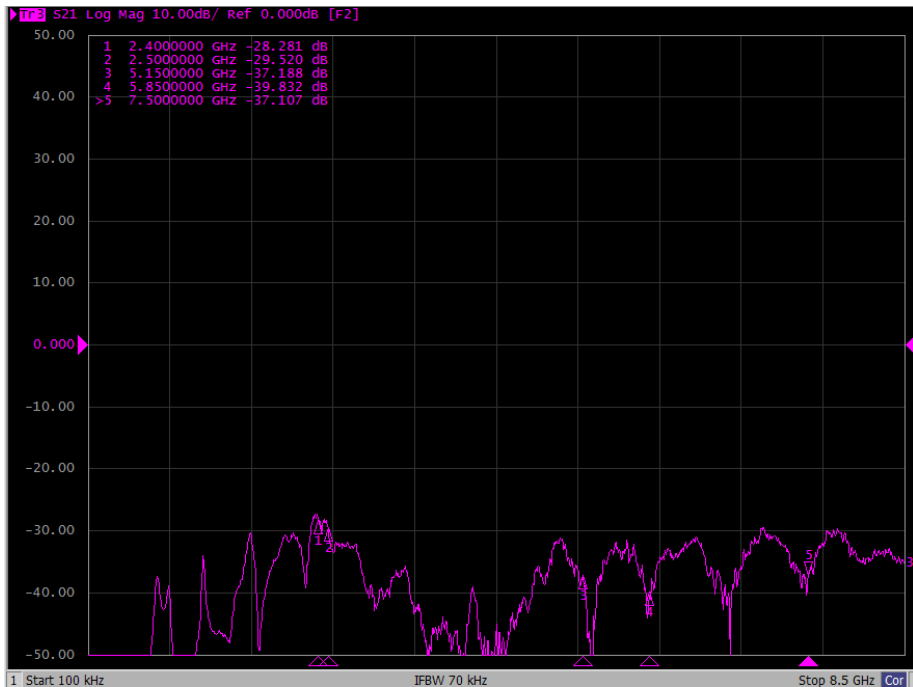

## D1-D3

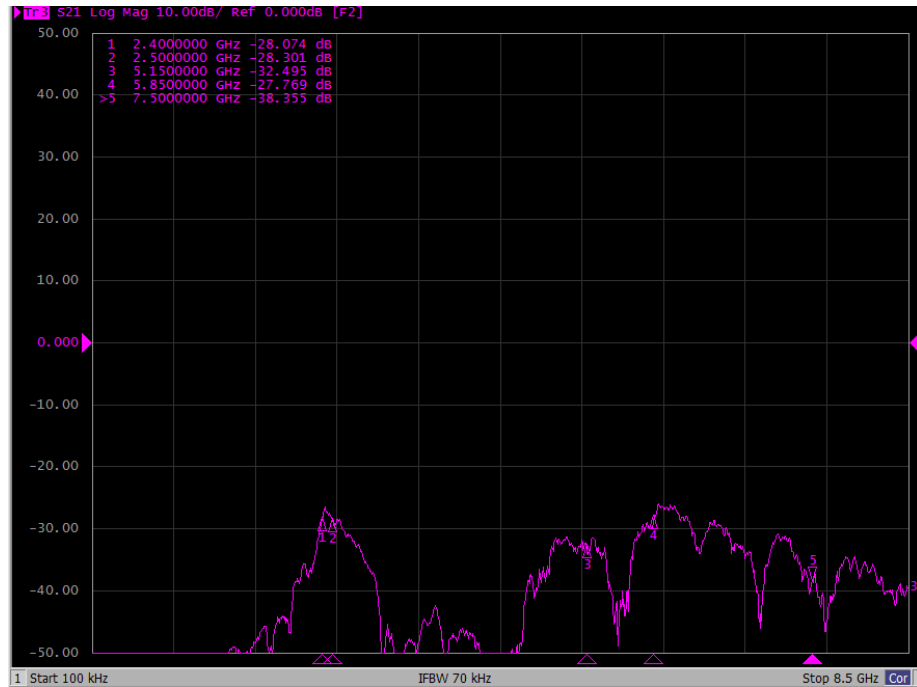

# Isolation Results

## D1-D4

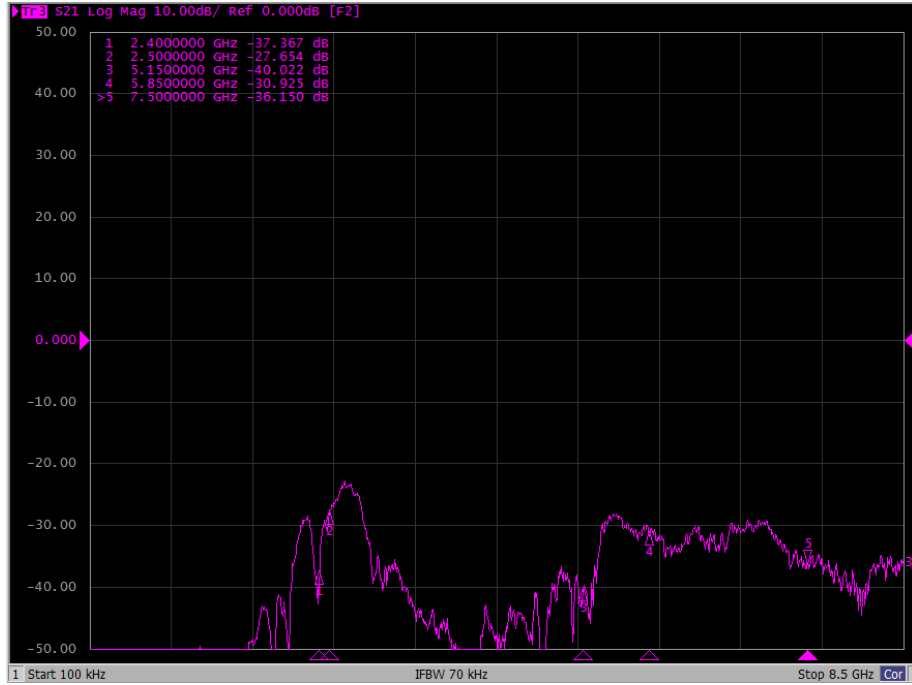

## D1-5G1

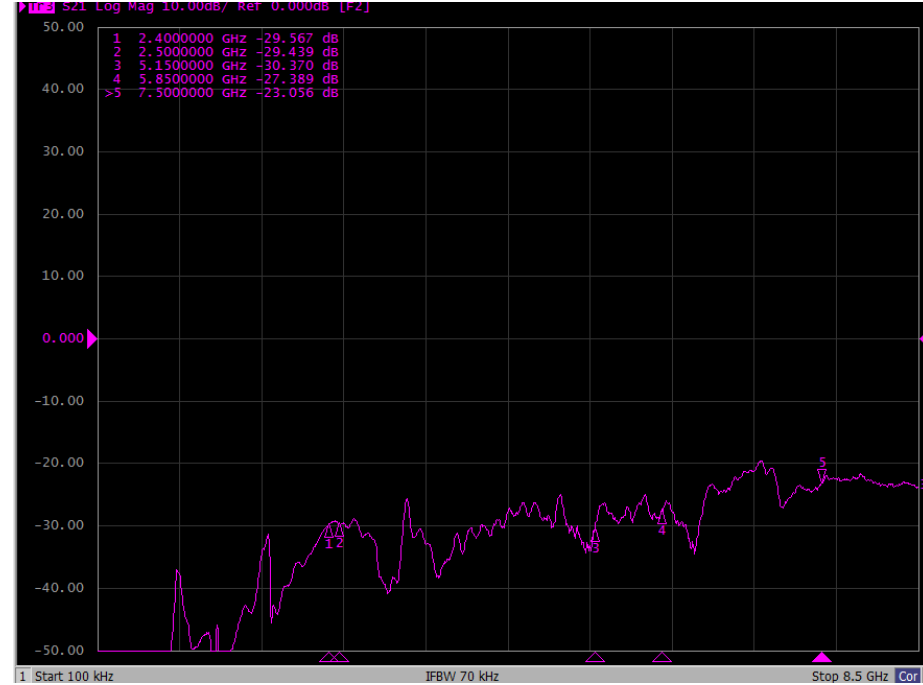

# Isolation Results

## D1-5G2

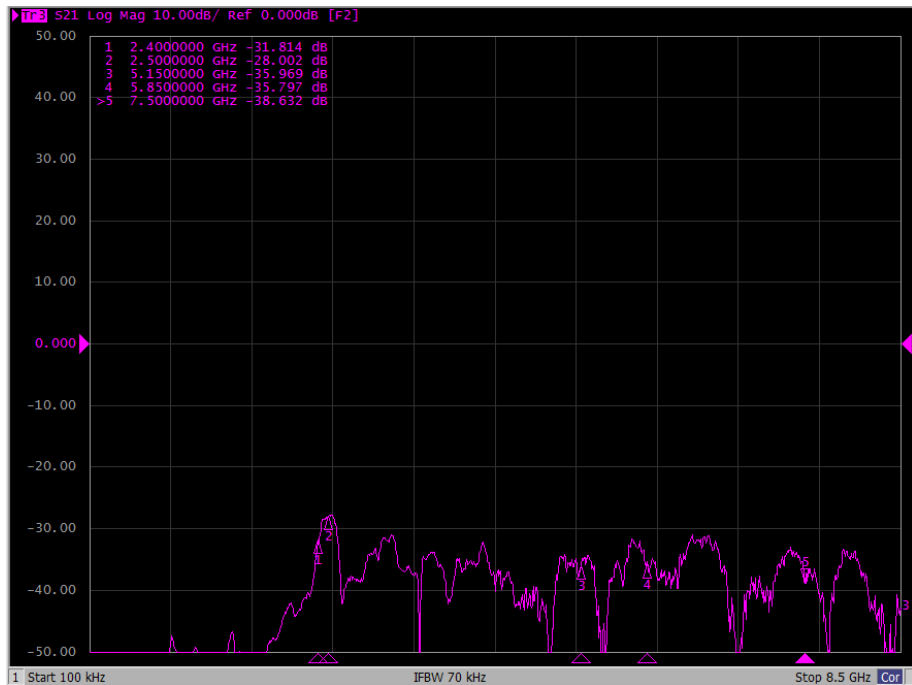

## D1-6G1

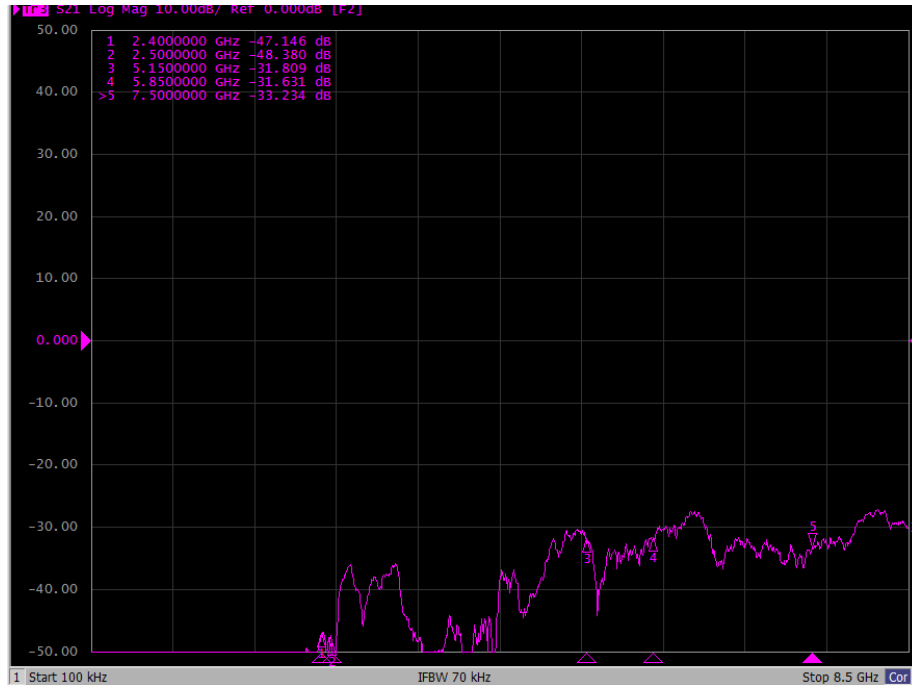

# Isolation Results

## D1-6G2

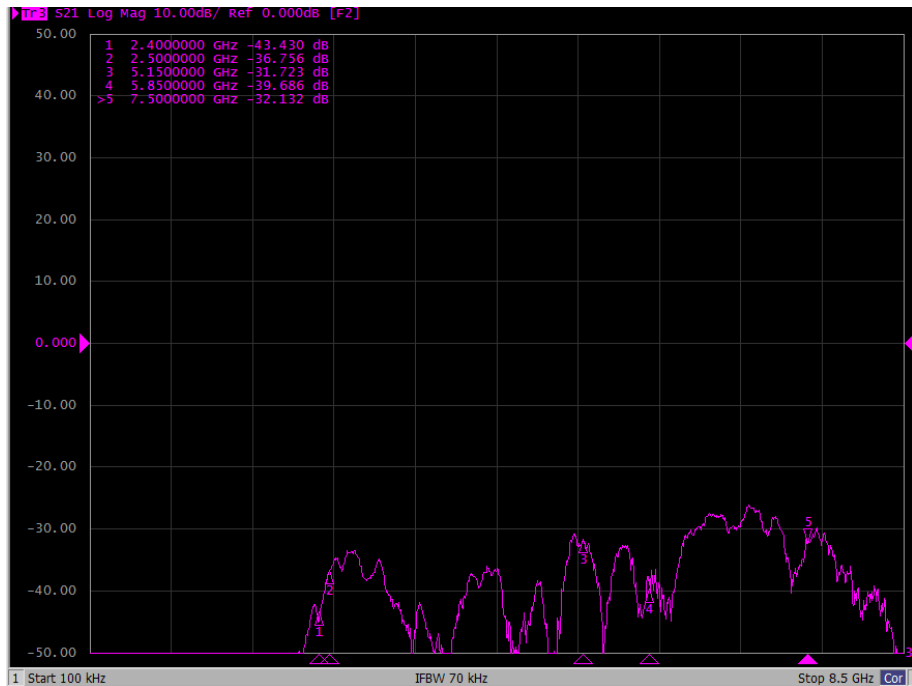

## D1-BT

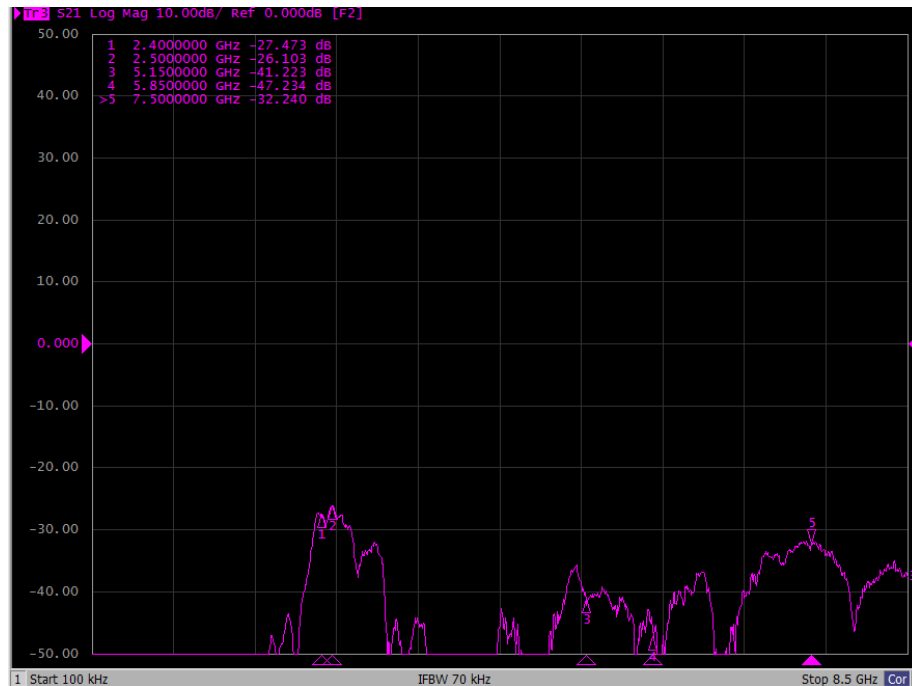

# Isolation Results

## D2-D3

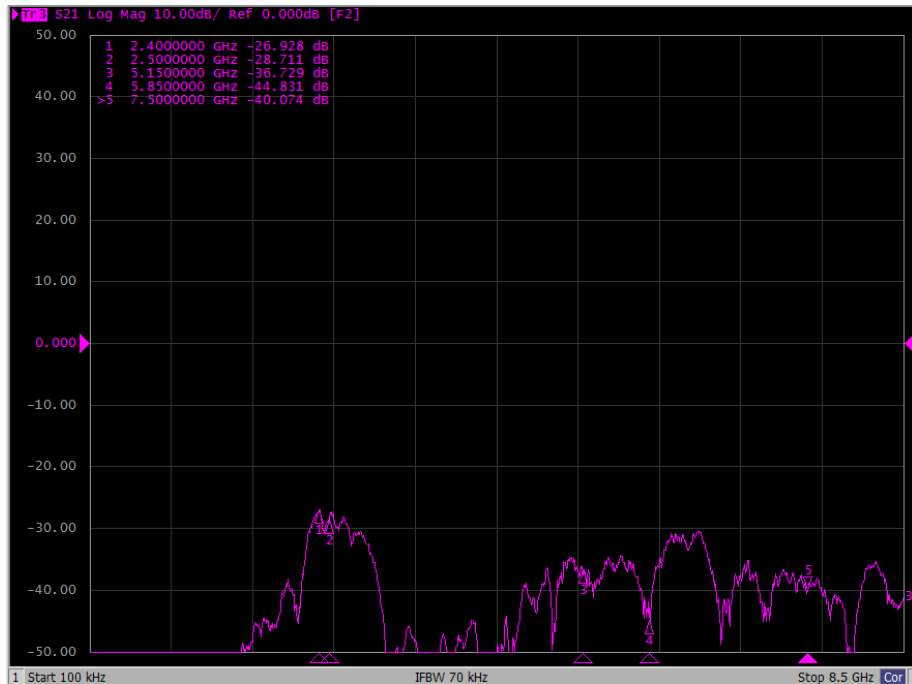

## D2-D4

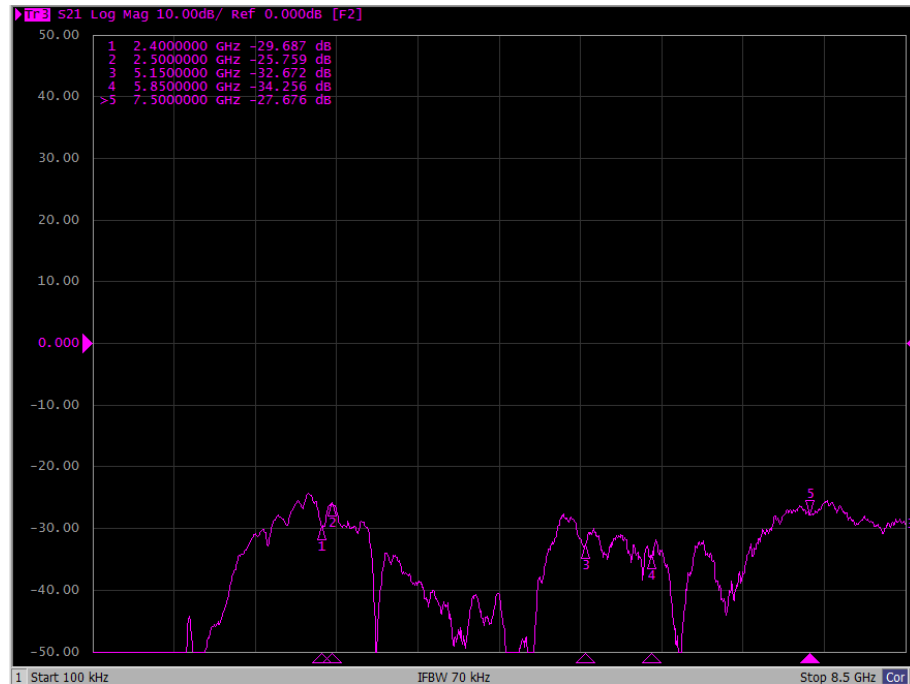



# Isolation Results

## D2-5G1

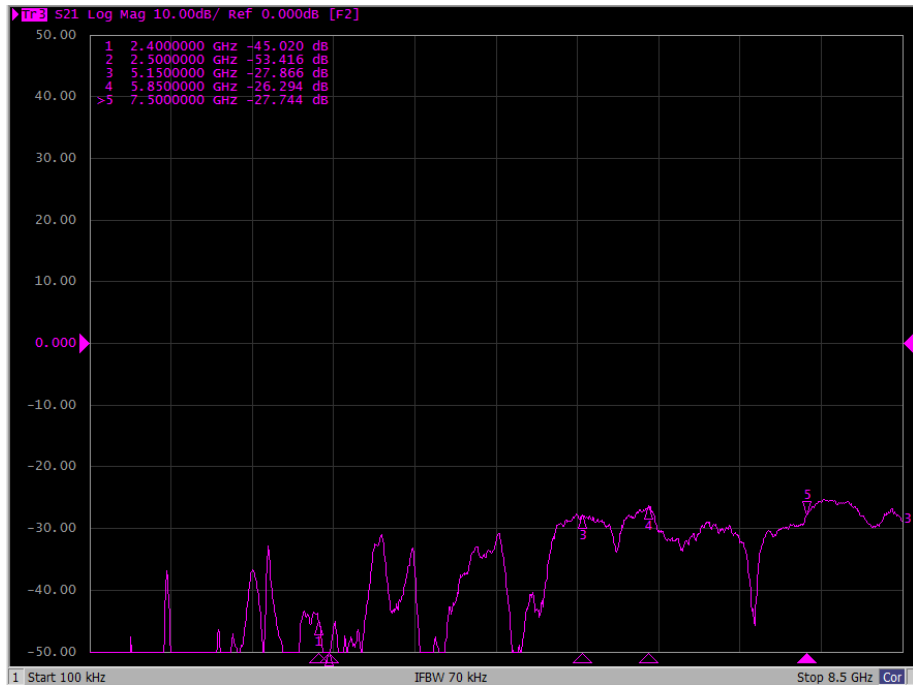

## D2-5G2

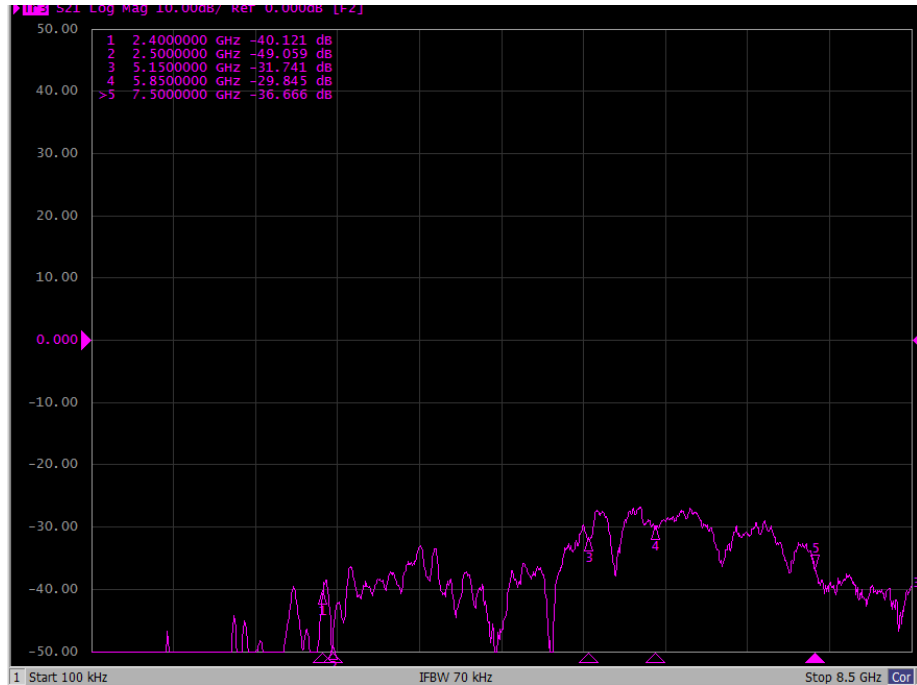

# Isolation Results

## D2-6G1

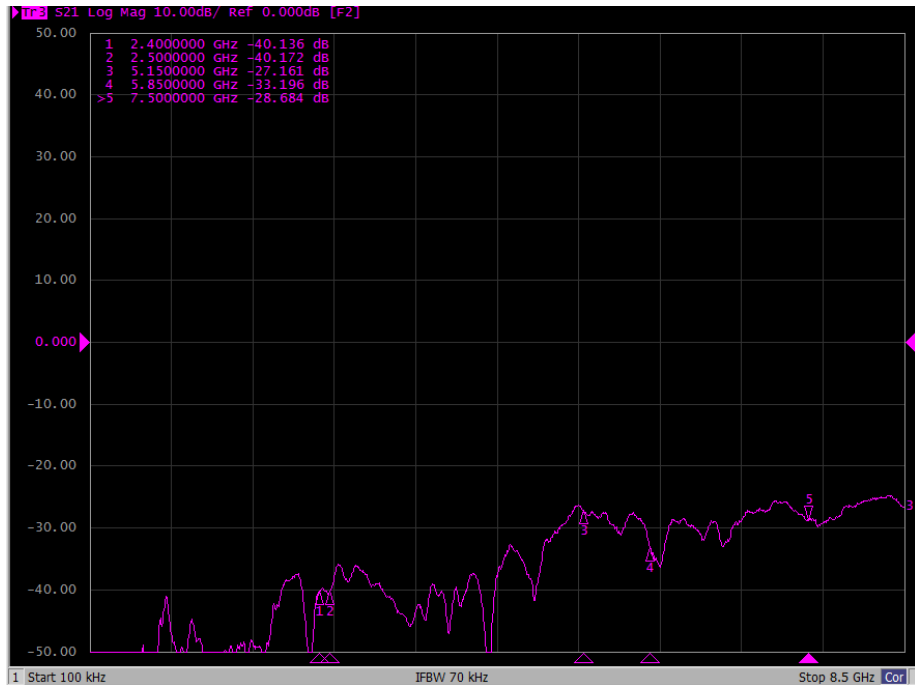

## D2-6G2

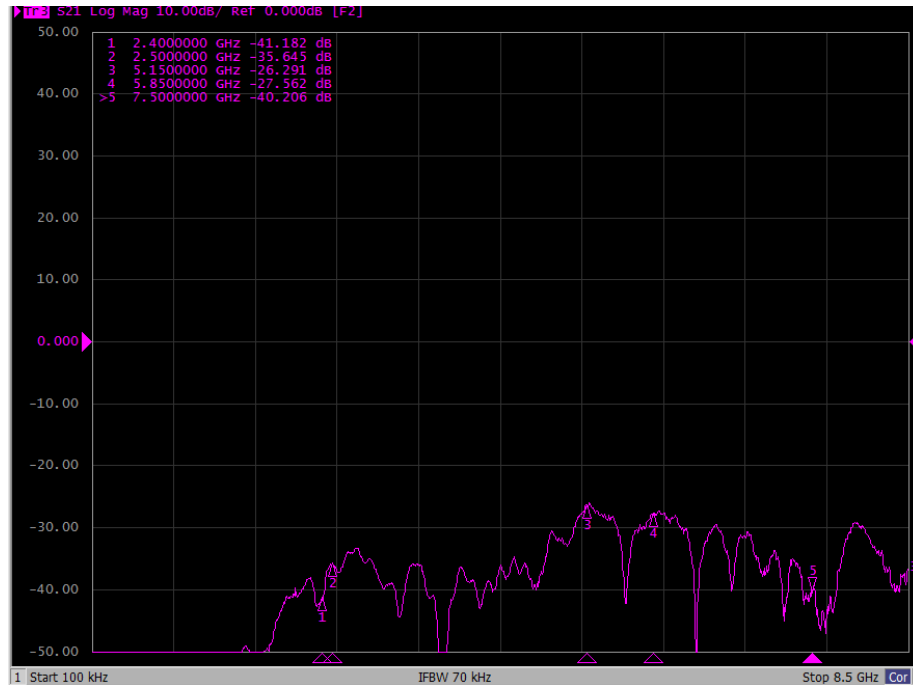

# Isolation Results

## D2-BT

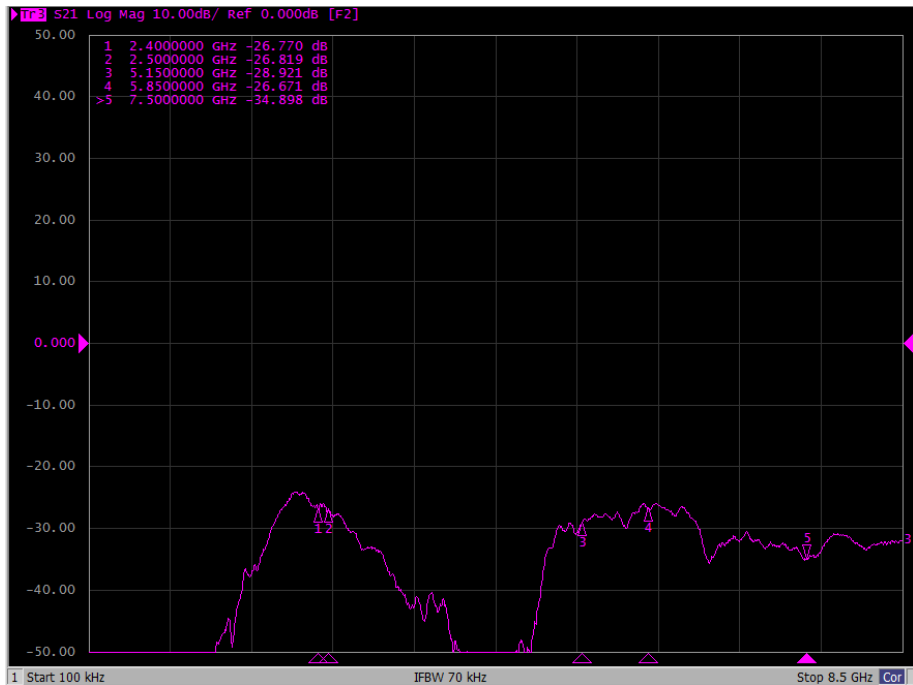

## D3-D4

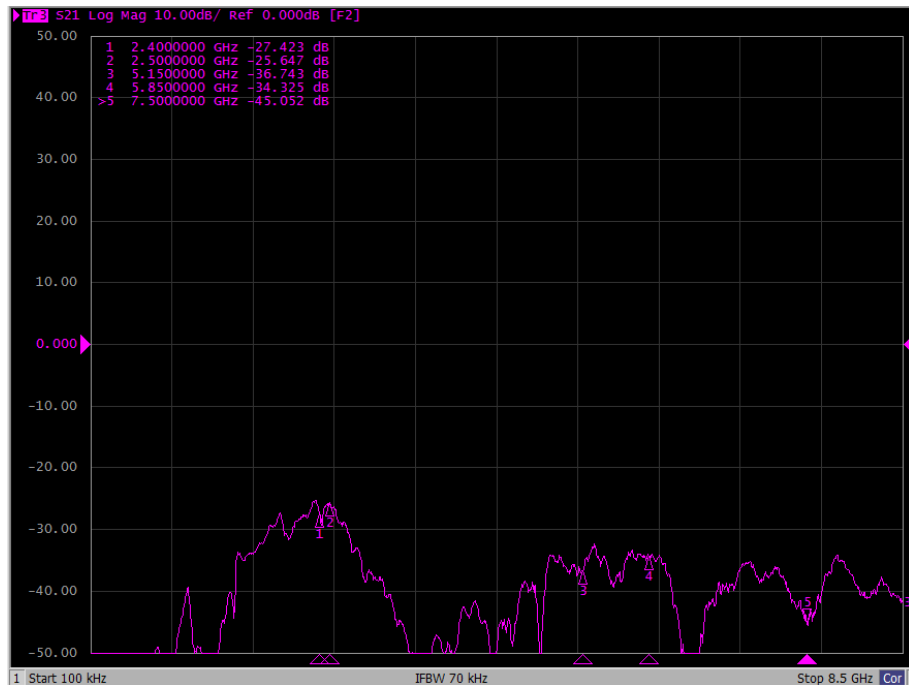

# Isolation Results

## D3-5G1

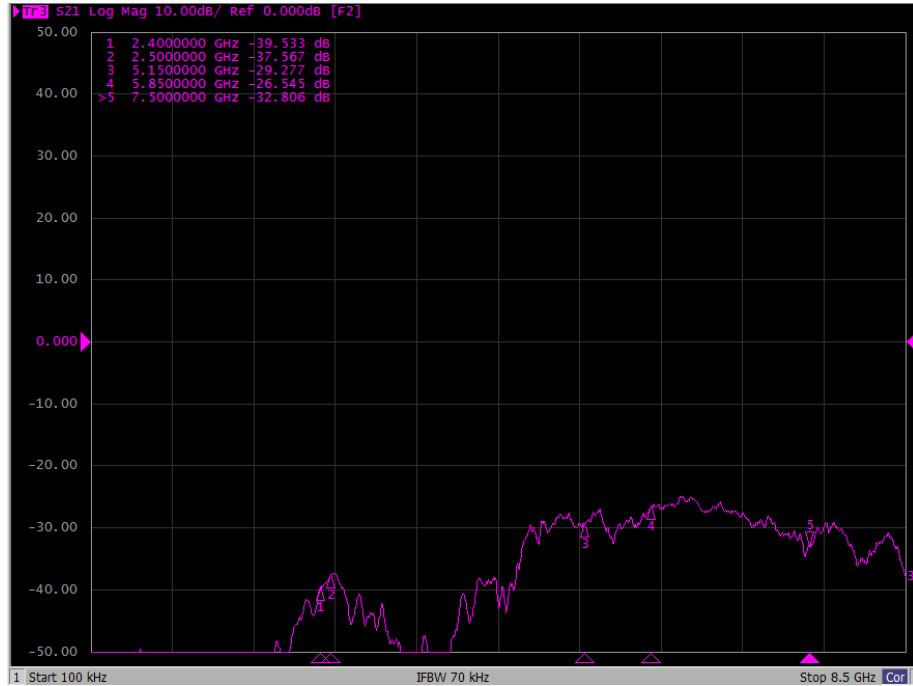

## D3-5G2

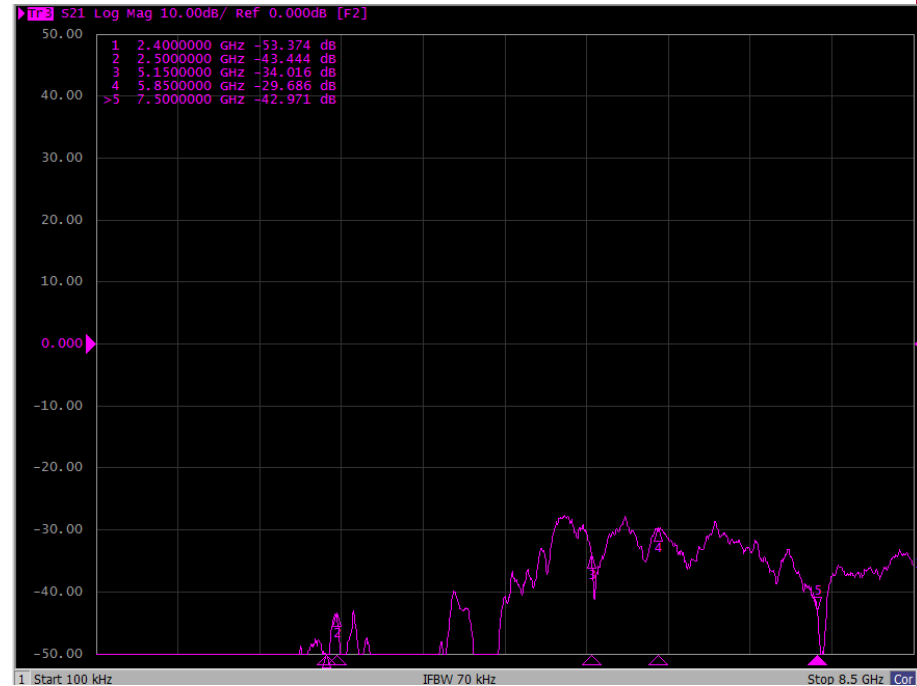

# Isolation Results

## D3-6G1

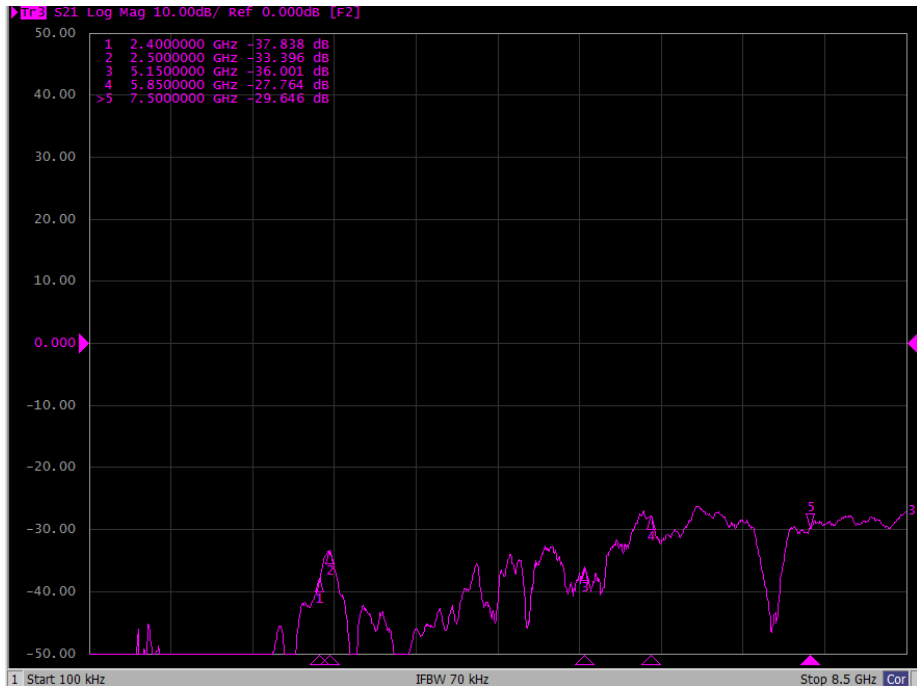

## D3-6G2

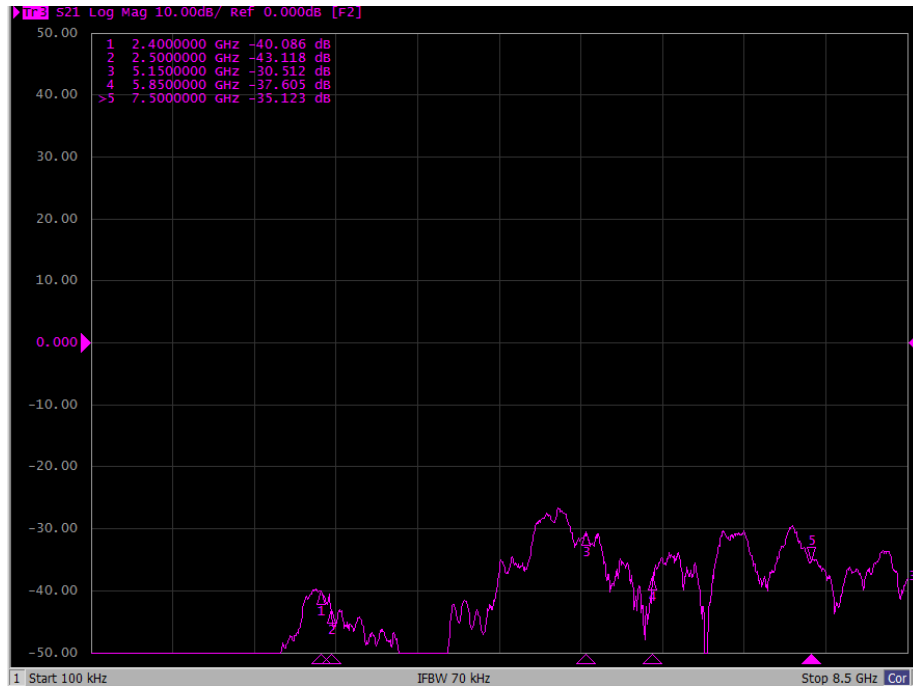

# Isolation Results

## D3-BT

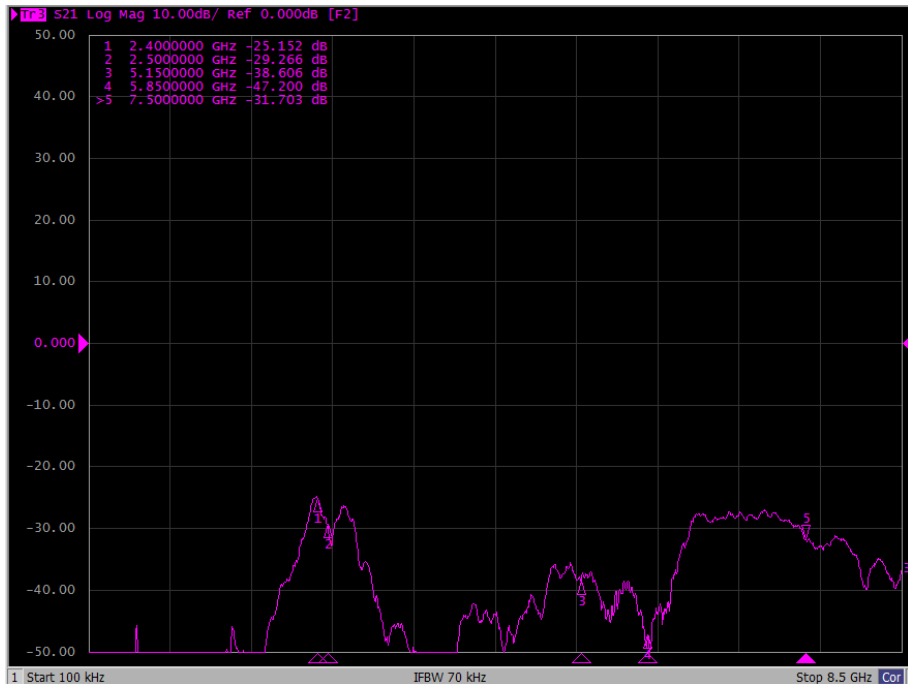

## D4-5G1

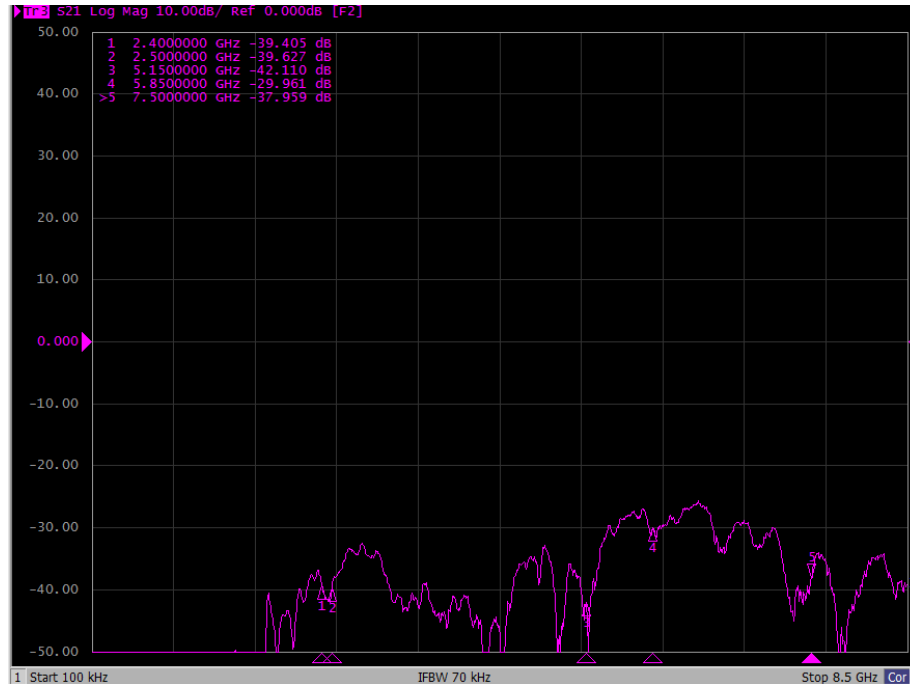

# Isolation Results

## D4-5G2

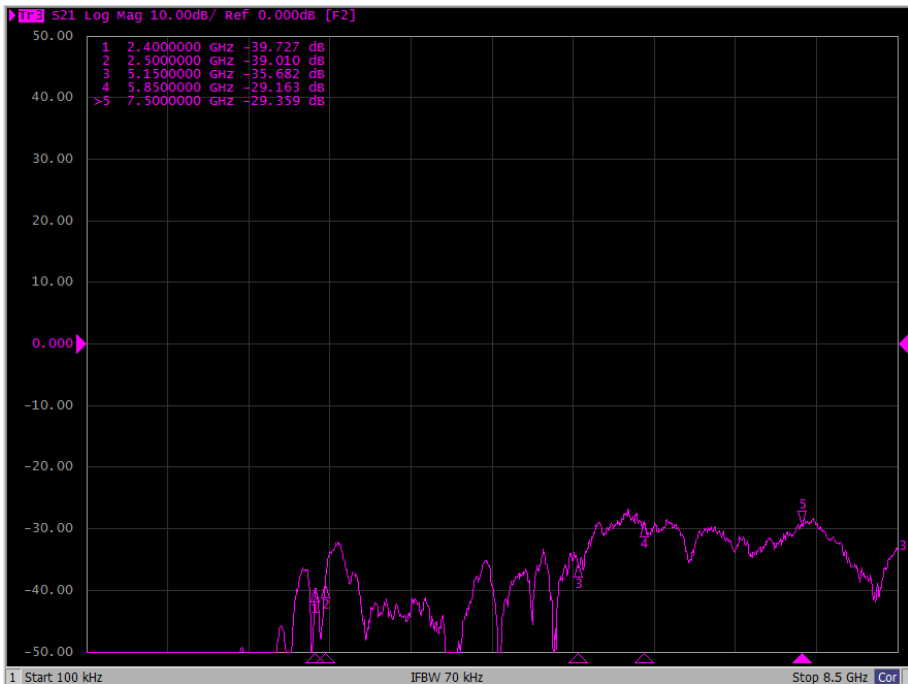

## D4-6G1

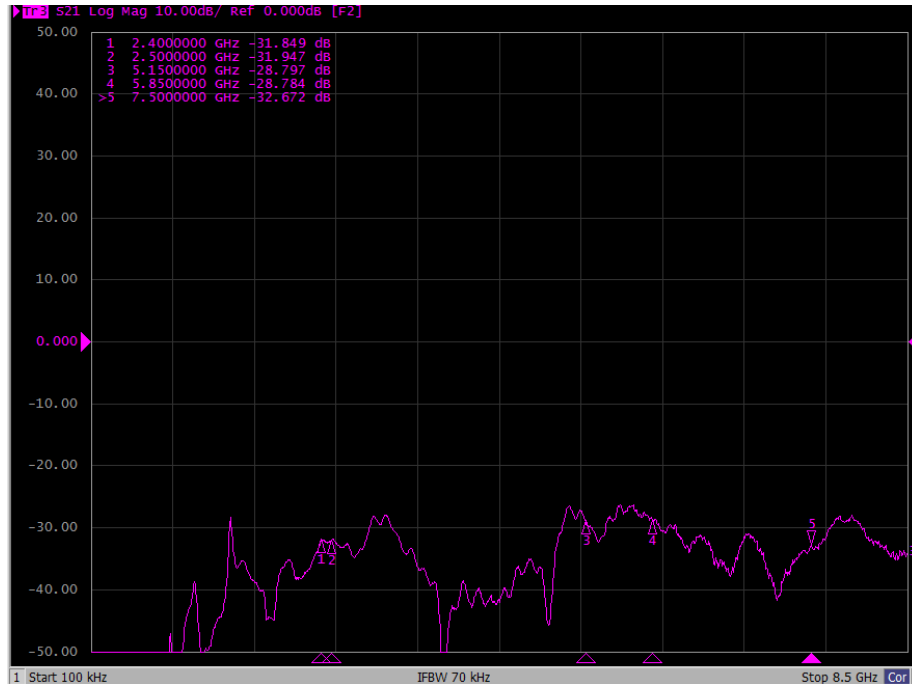

# Isolation Results

## D4-6G2

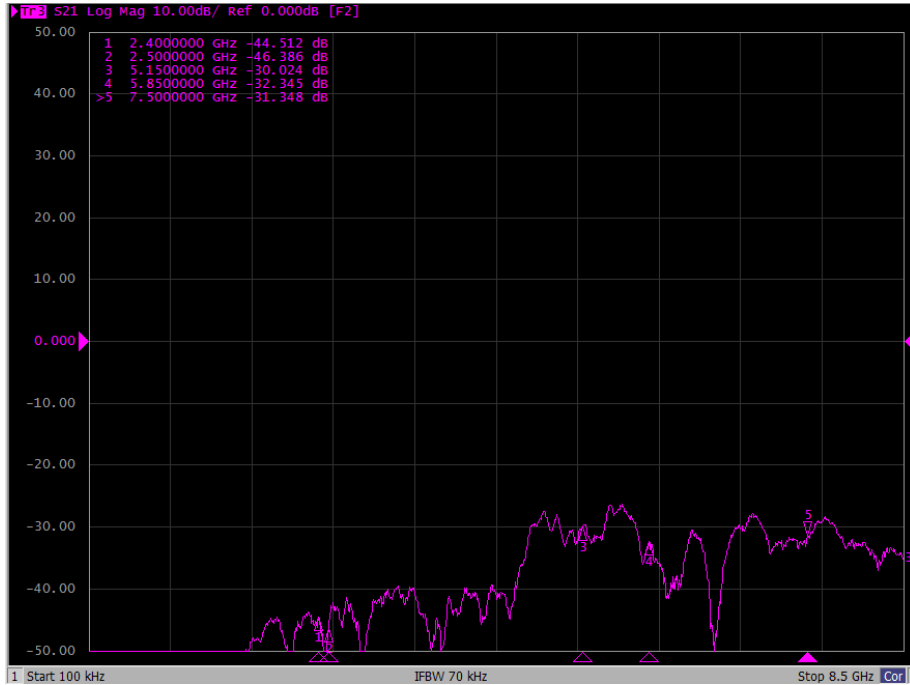

## D4-BT

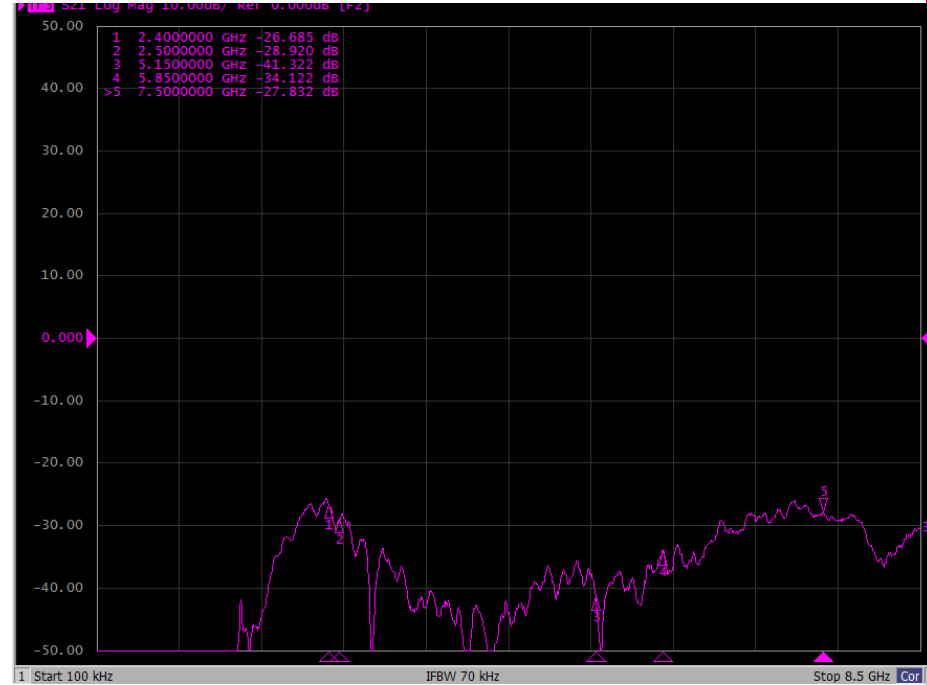



# Isolation Results

## 5G1-5G2

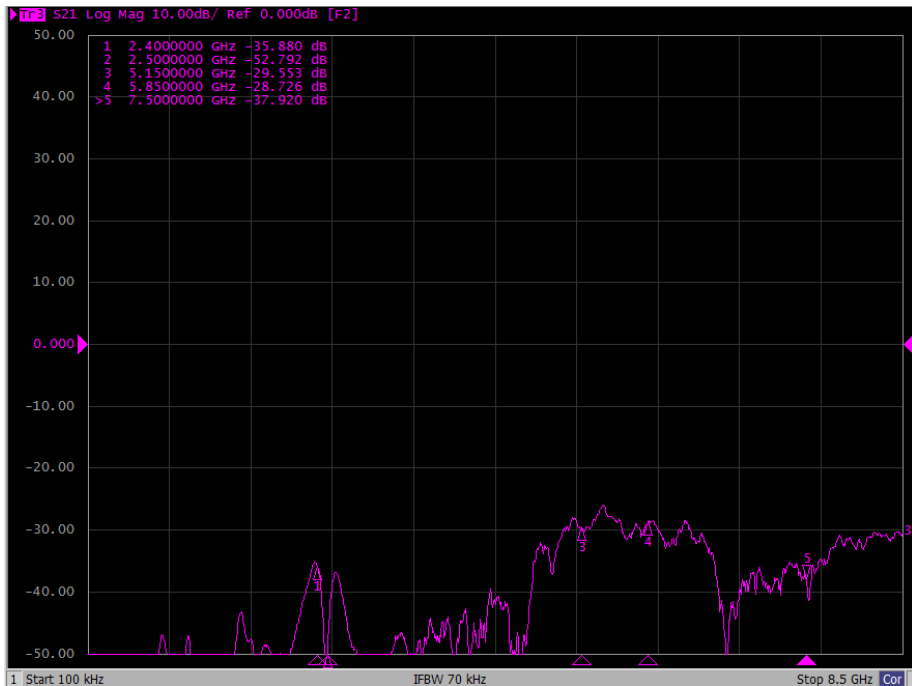

## 5G1-6G1

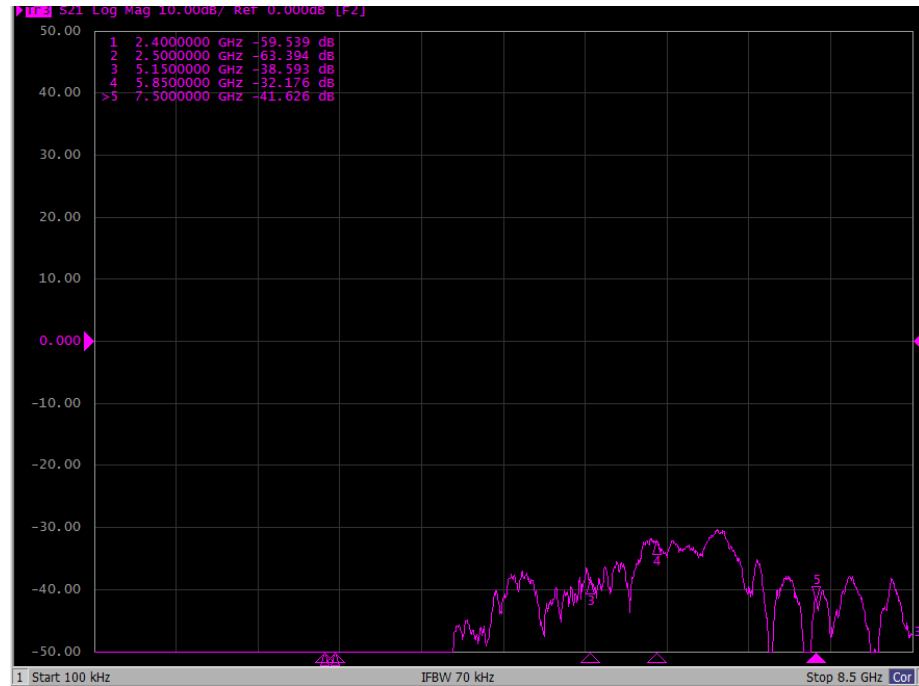

# Isolation Results

## 5G1-6G2

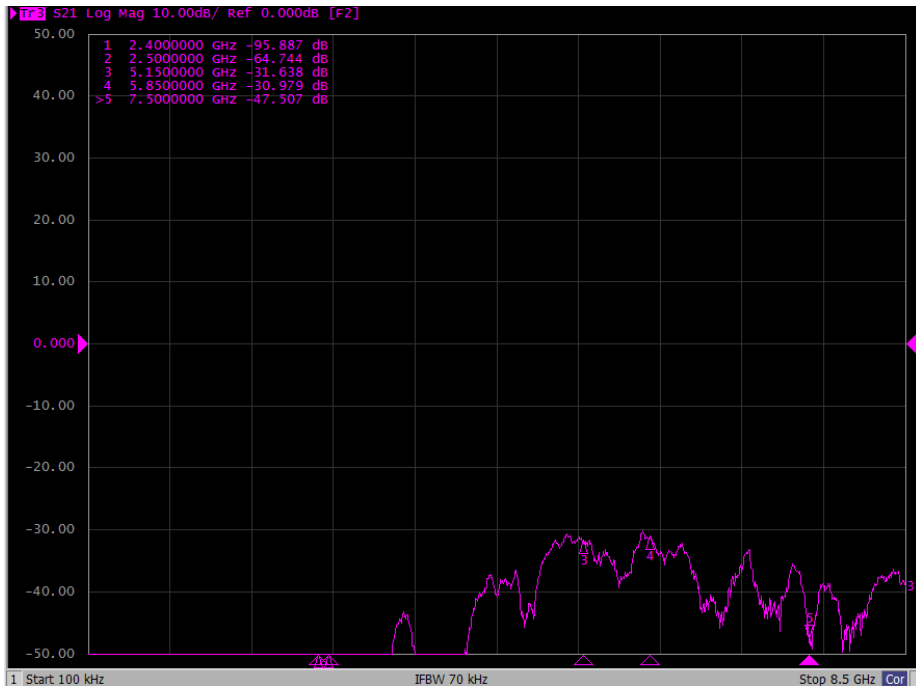

## 5G1-BT

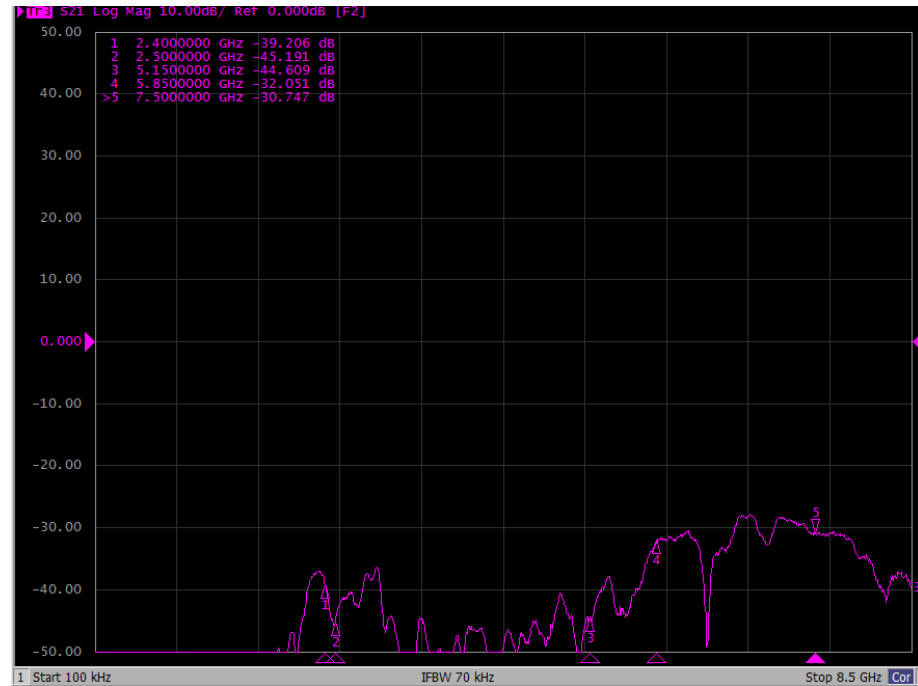

# Isolation Results

## 5G2-6G1

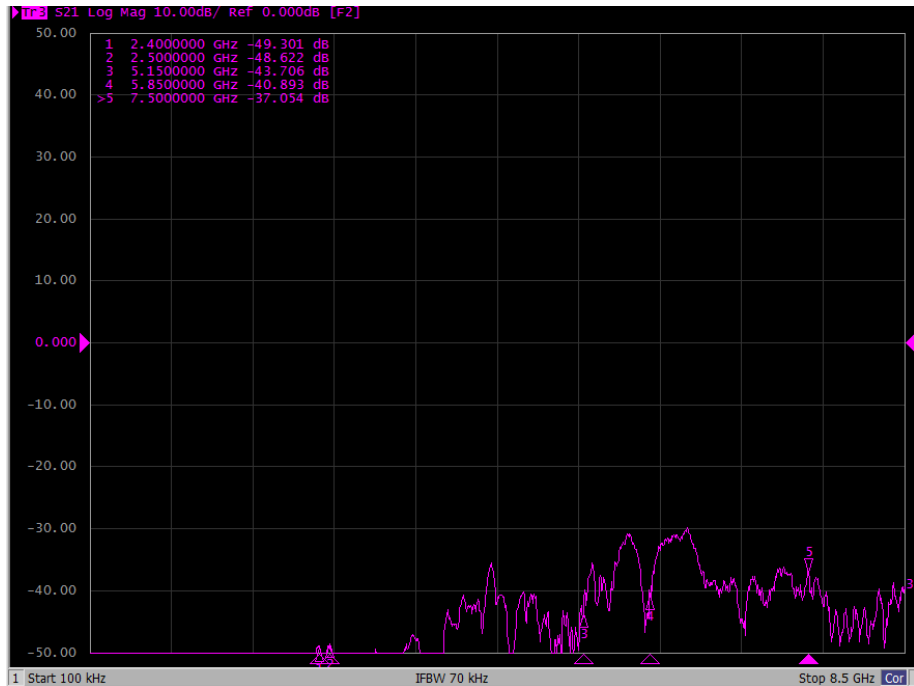

## 5G2-6G2

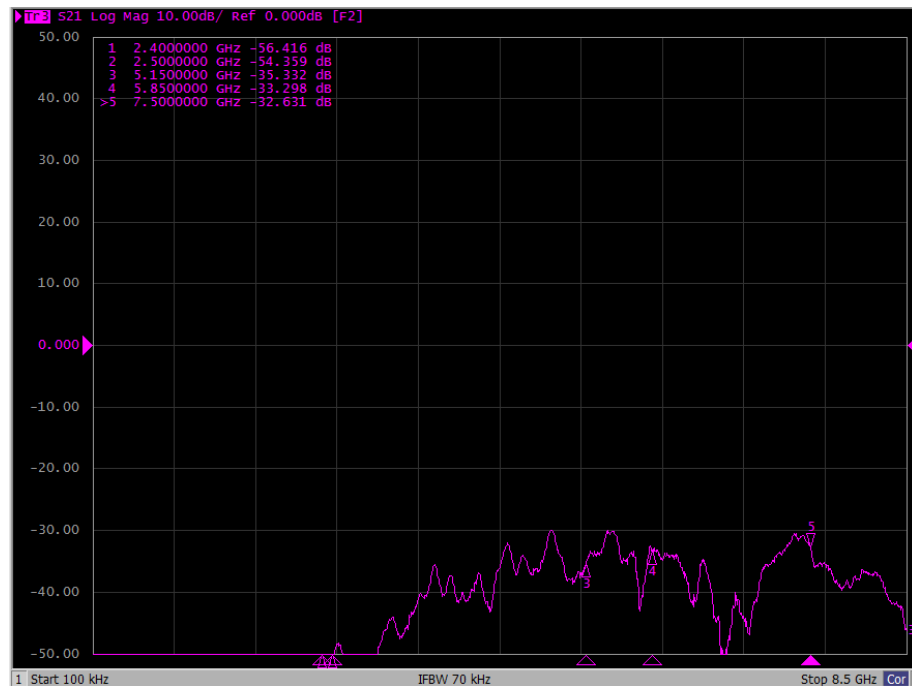

# Isolation Results

## 5G2-BT

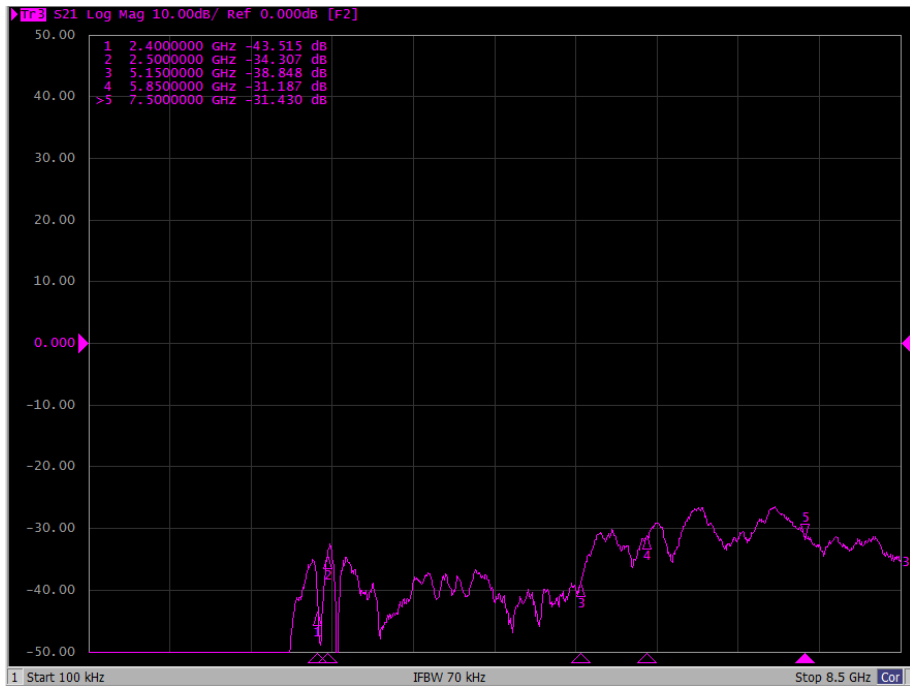

## 6G1-6G2

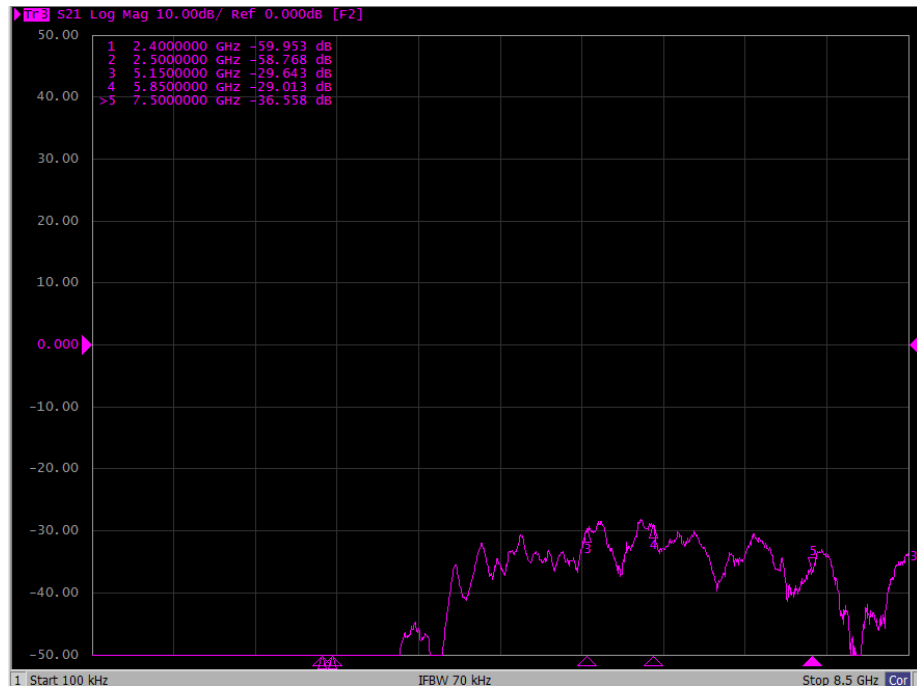

# Isolation Results

## 6G1-BT

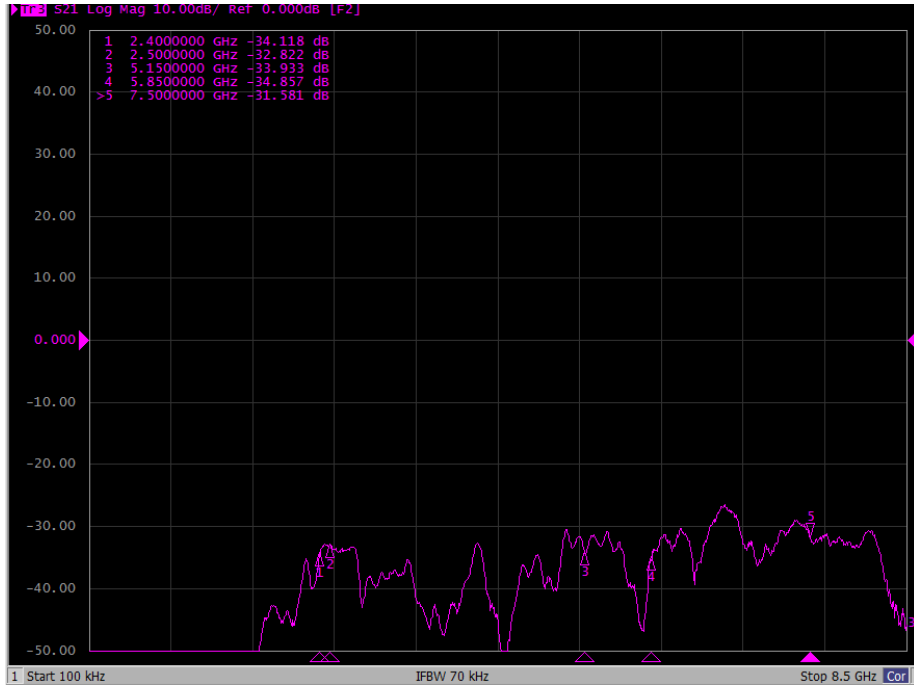

## 6G2-BT

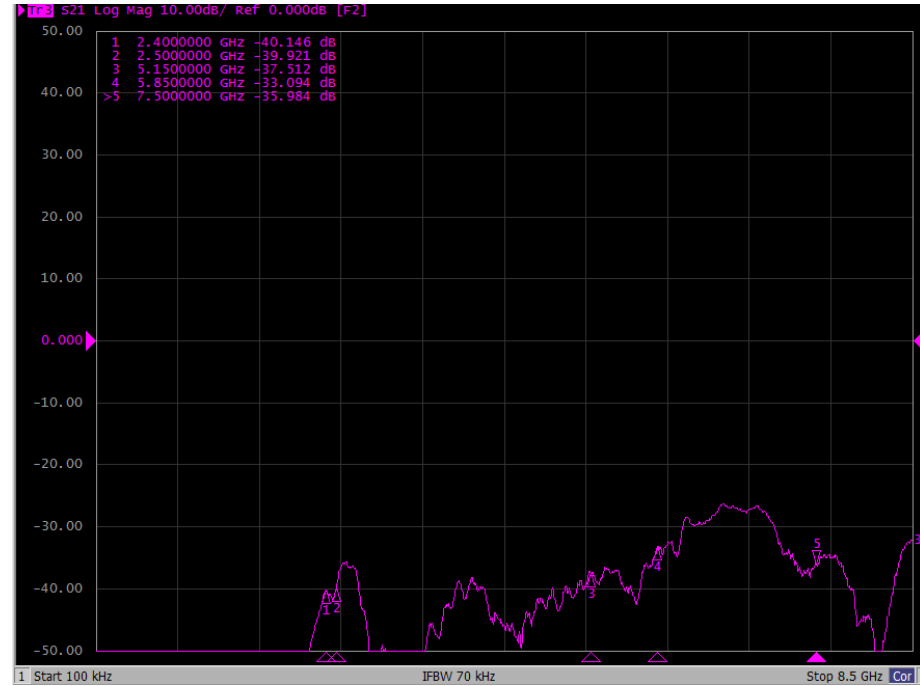

# 2D Radiation Pattern Results

WIFI 2G

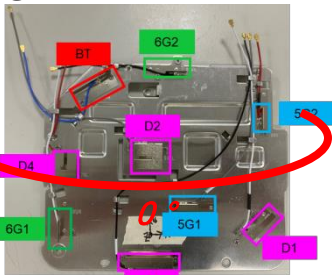
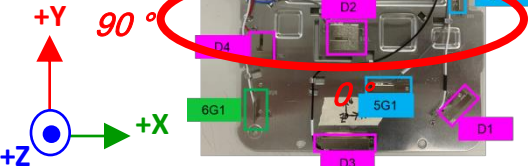

XZ-plane

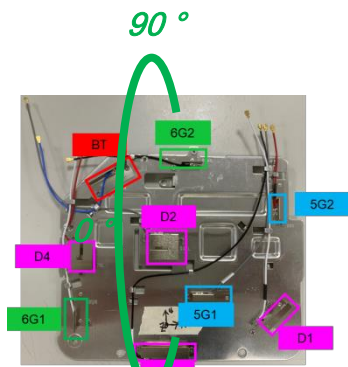

YZ-plane

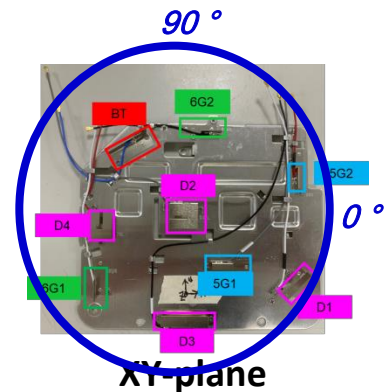

XY-plane

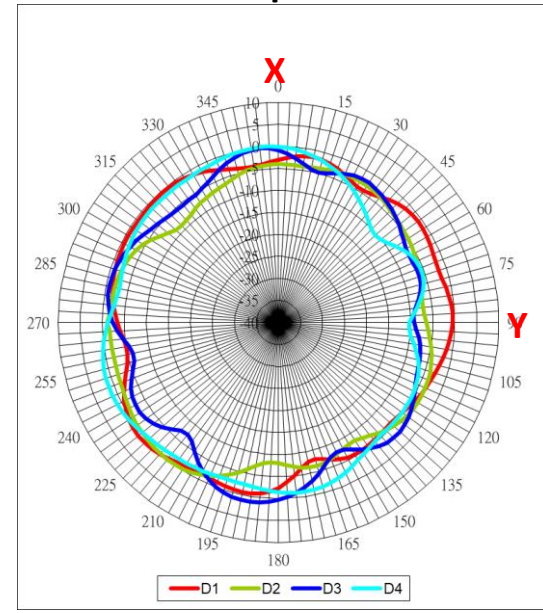
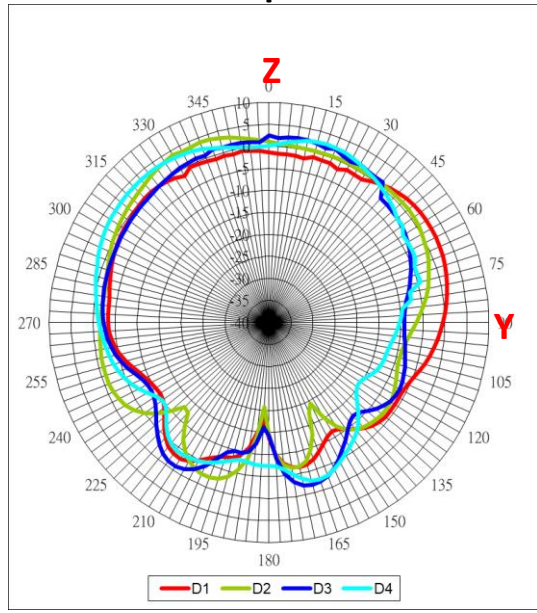
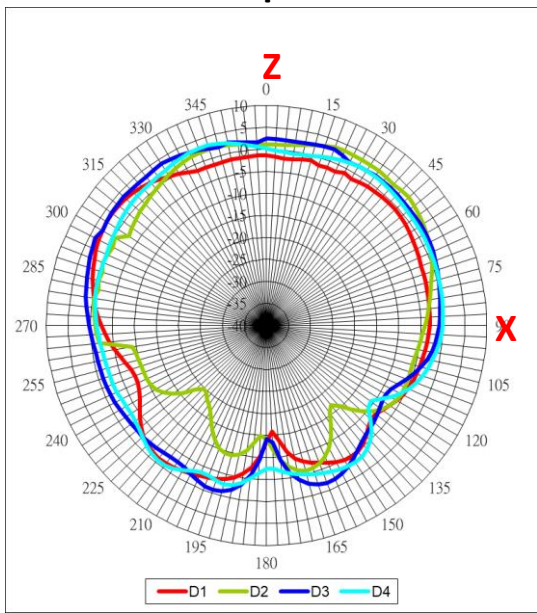

# 2D Radiation Pattern Results

## WIFI 5G/5G Single

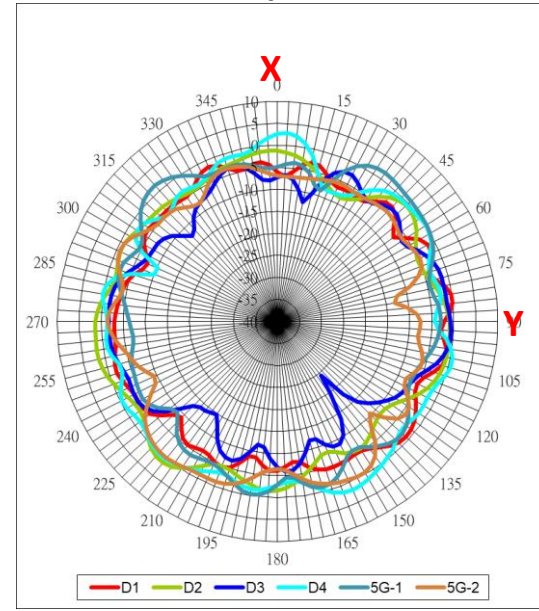
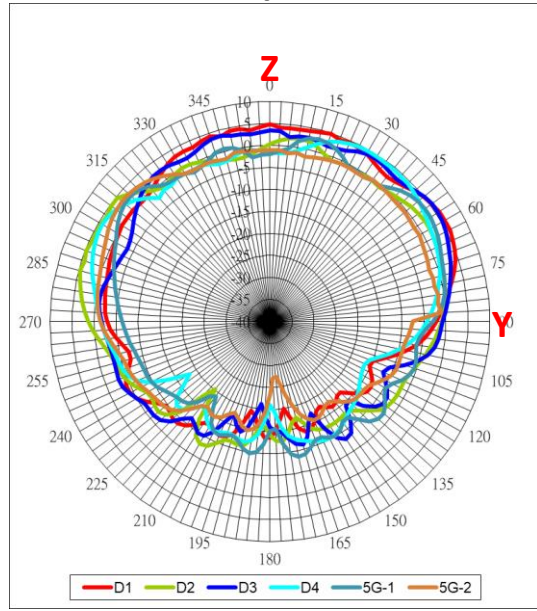
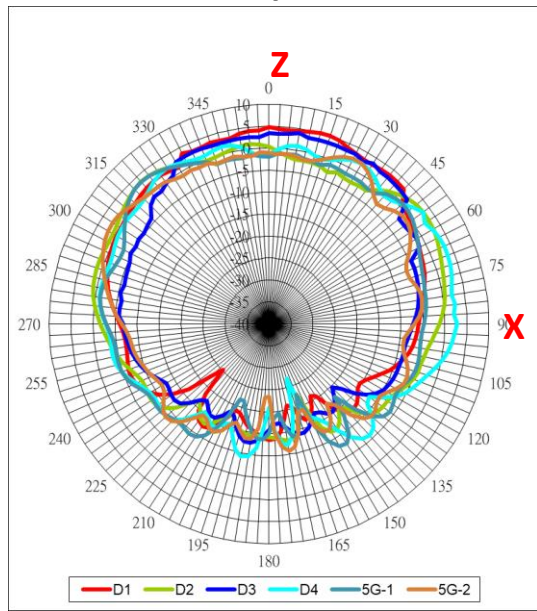
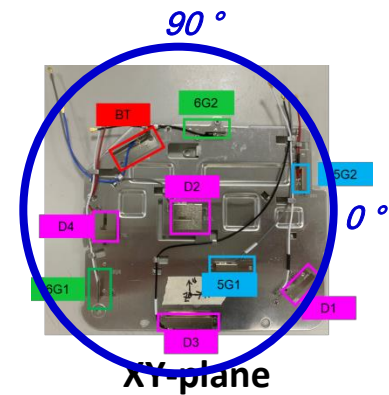
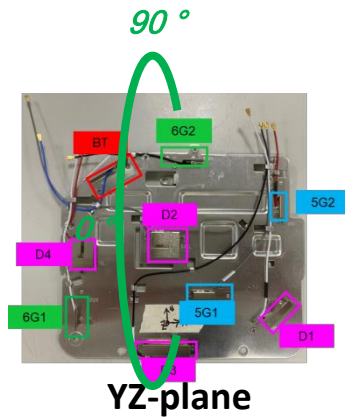
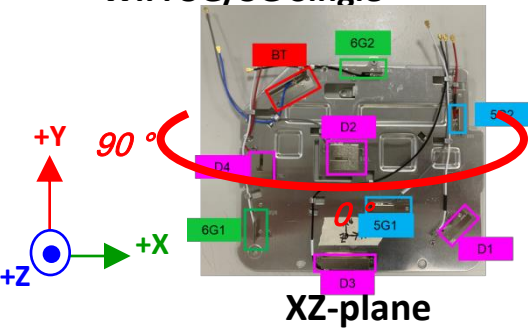



# 2D Radiation Pattern Results

## 6G Single

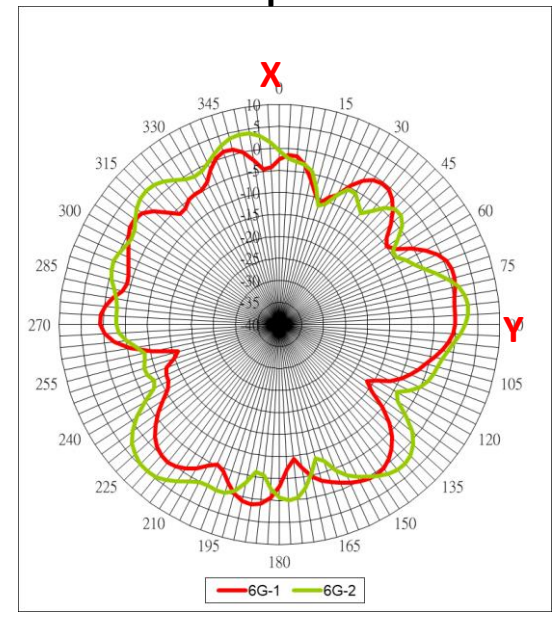
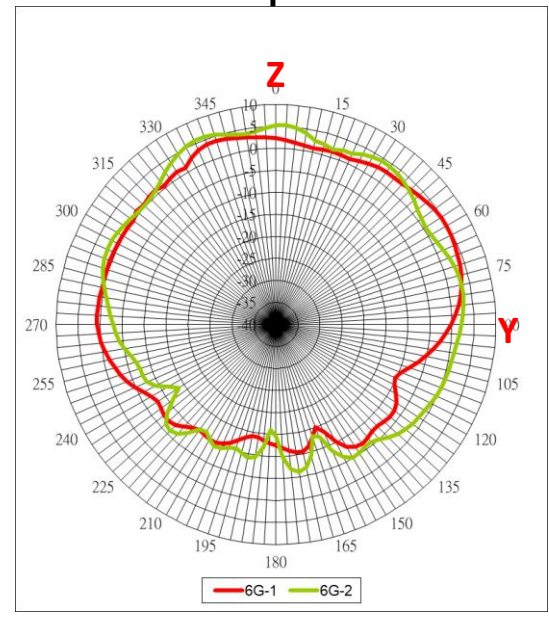
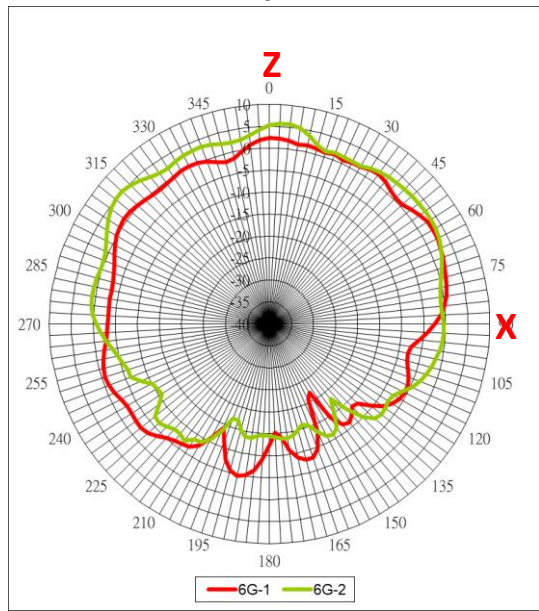
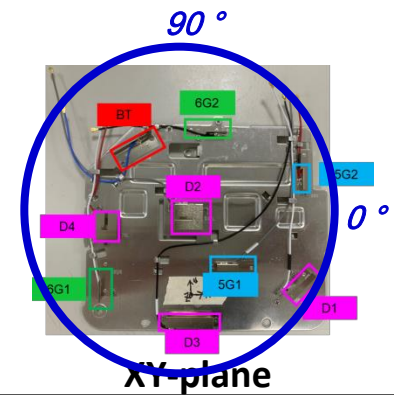
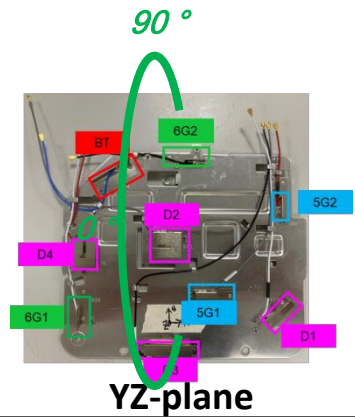
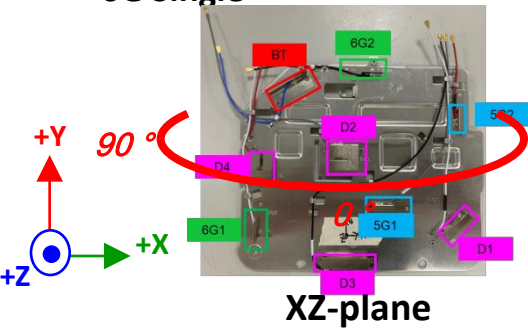



# 2D Radiation Pattern Results

BT

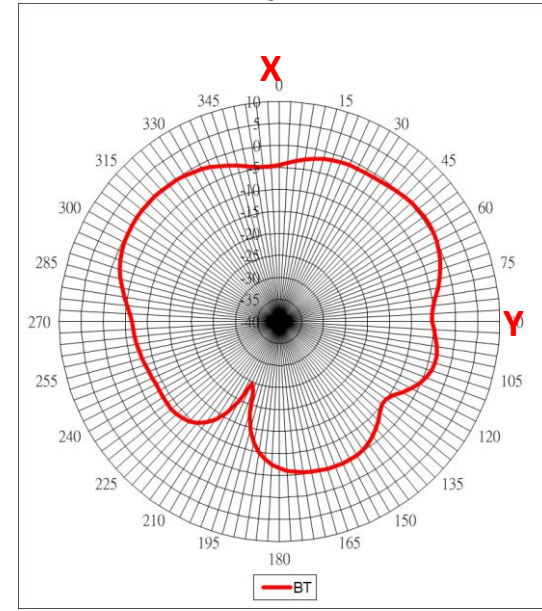
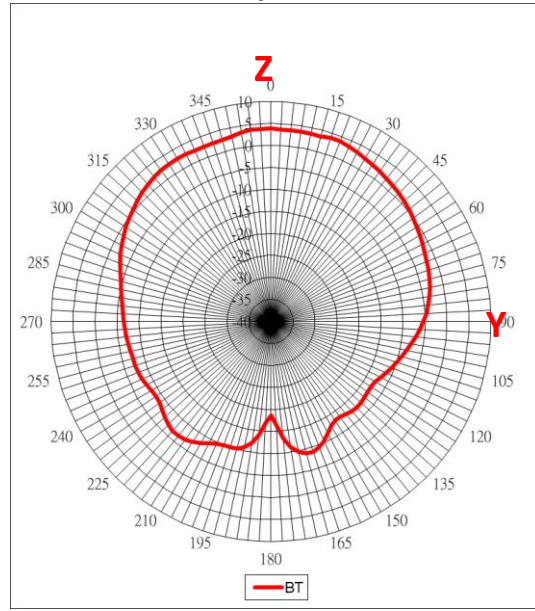
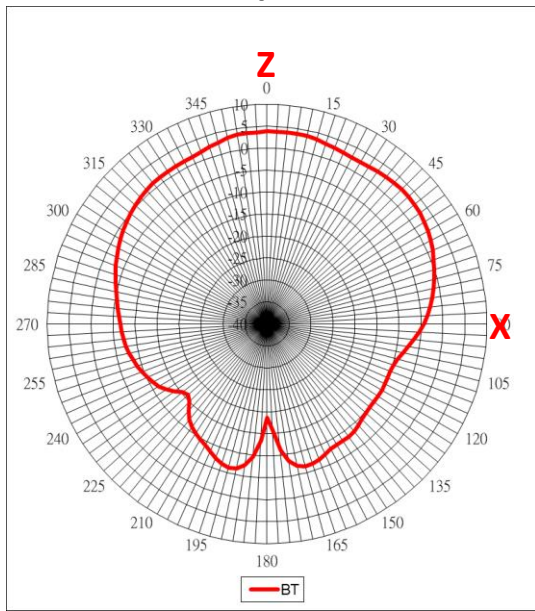
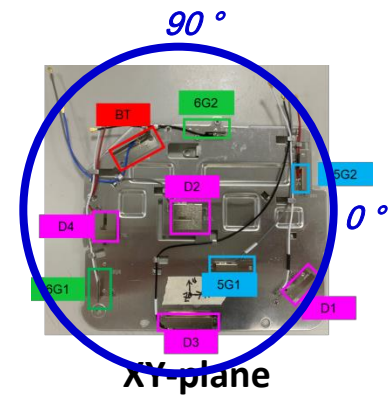
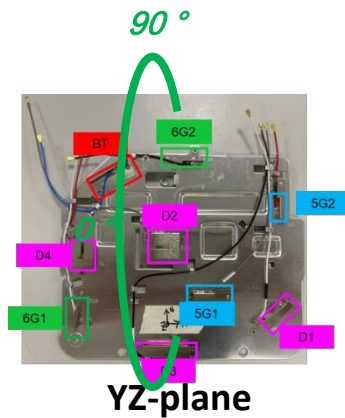
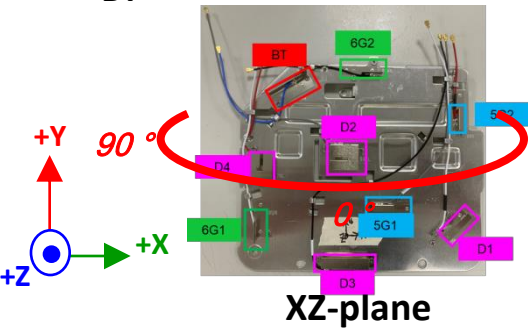

# 3D Radiation Pattern Results

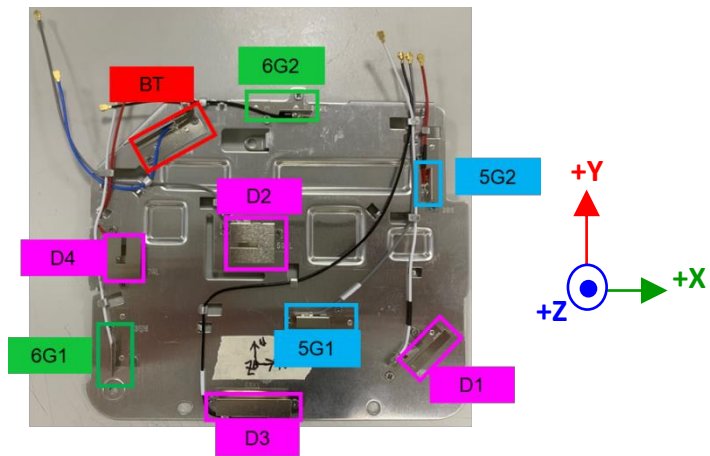

D1\_2G

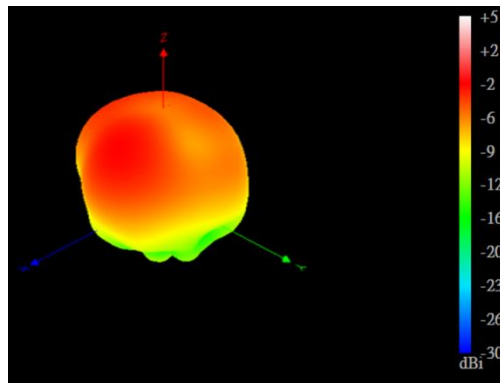

D1\_5G

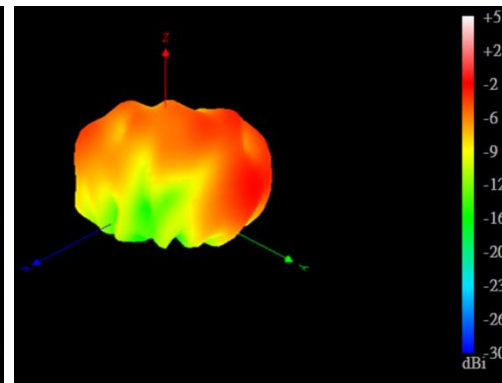

D2\_2G

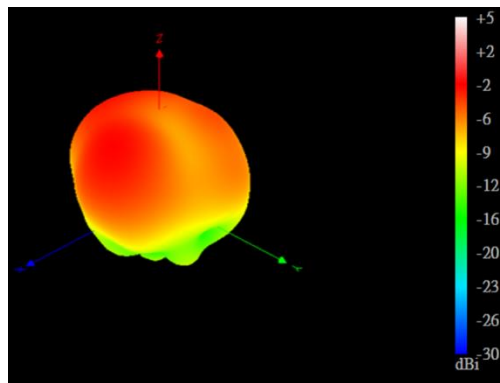

D2\_5G

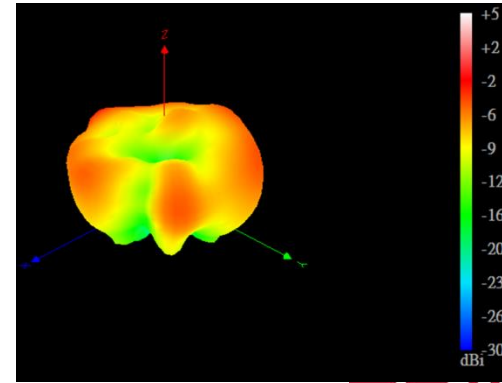

# 3D Radiation Pattern Results

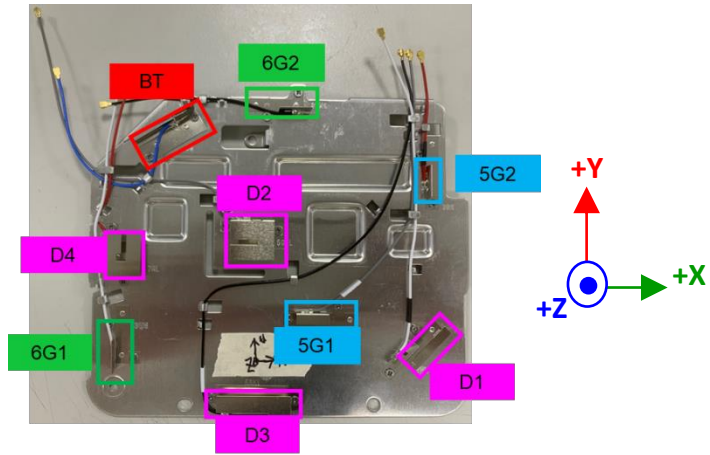

D3\_2G

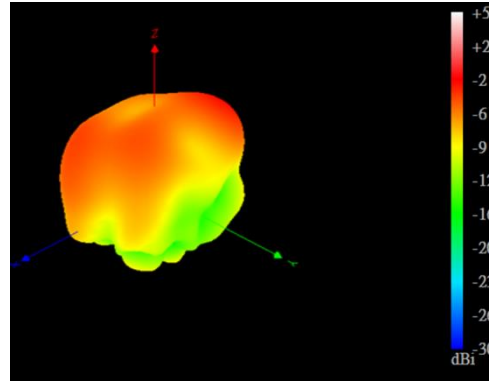

D3\_5G

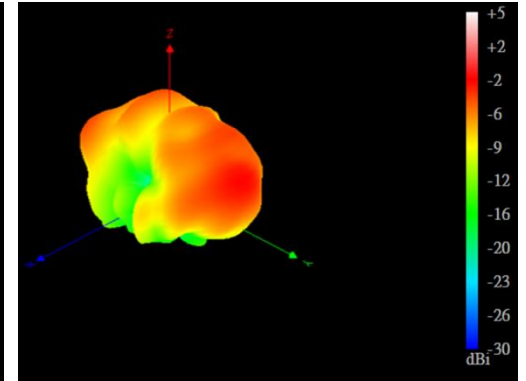

D4\_2G

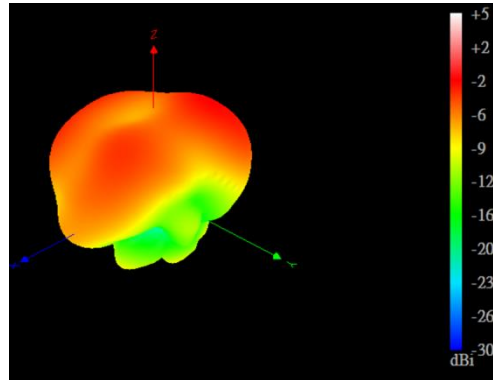

D4\_5G

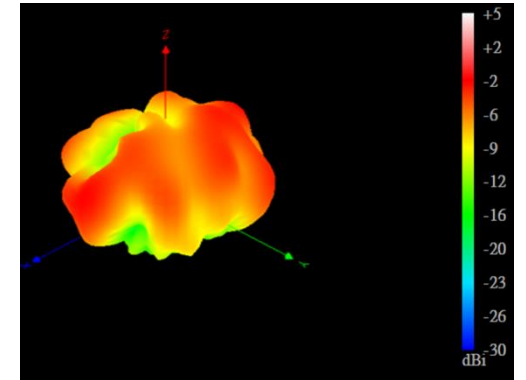

# 3D Radiation Pattern Results

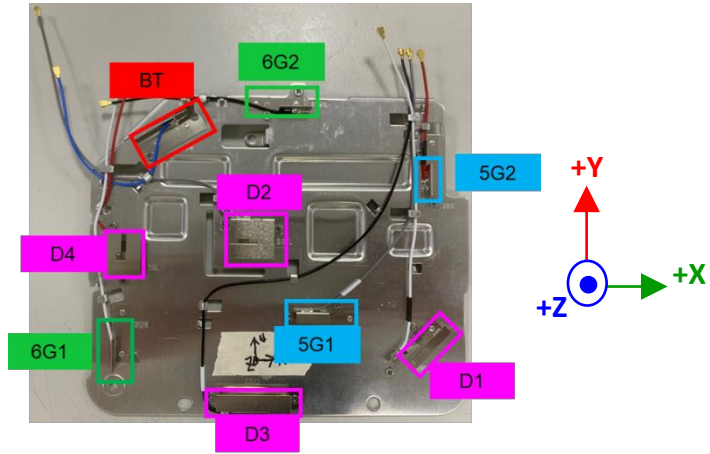

5G1

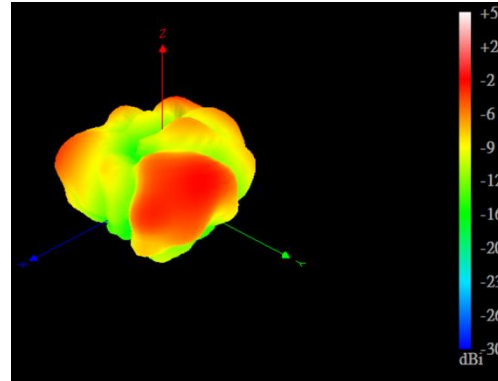

5G2

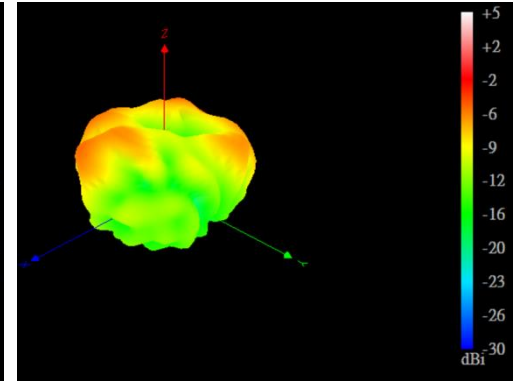

6G1

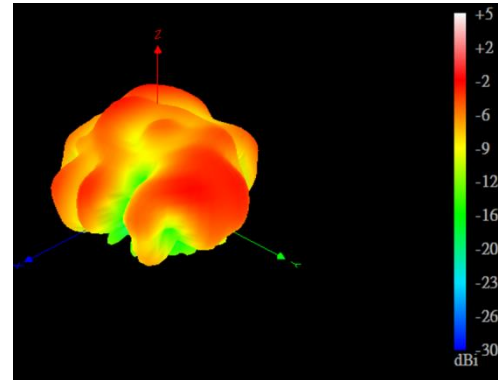

6G2

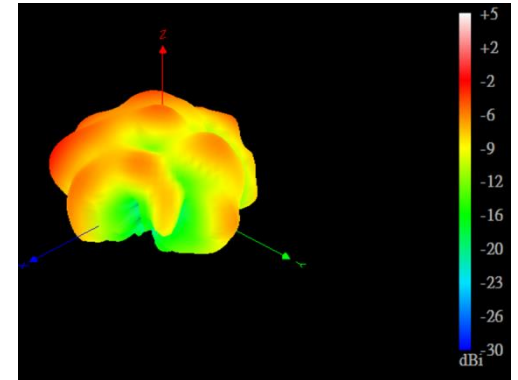

# 3D Radiation Pattern Results

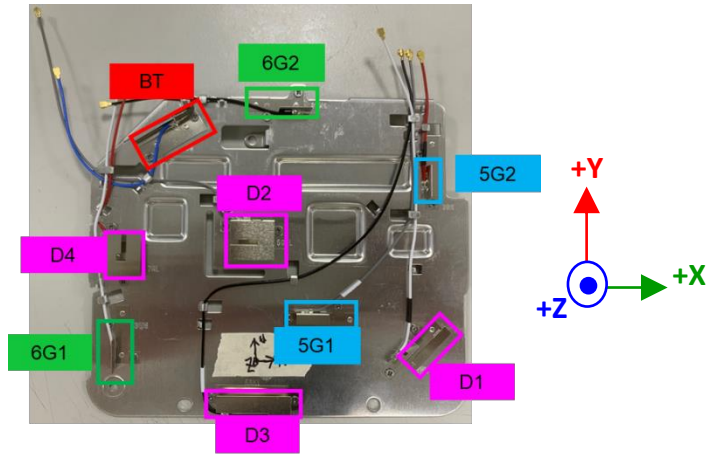

BT

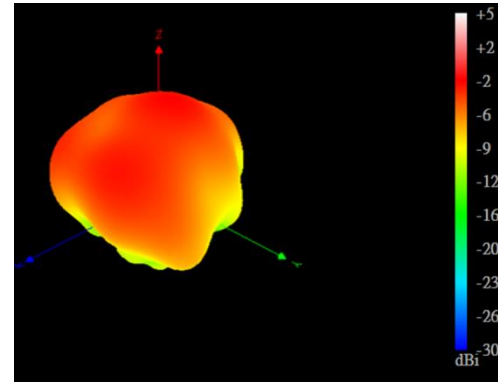

# Results Summary

## Peak gain & Efficiency – BT

Frequency (MHz)	Peak Gain (dBi)	Efficiency (%)
2400	3.82	76.24
2410	3.43	75.19
2420	3.03	77.65
2430	3.31	76.77
2440	3.15	78.98
2450	3.23	76.03
2460	3.39	78.08
2470	3.96	79.66
2480	3.55	77.5
2490	3.38	75.36
2500	3.43	75.53

## Peak gain & Efficiency – D1

Frequency (MHz)	Peak Gain (dBi)	Efficiency (%)
2400	3.6	75.12
2450	3.89	77.68
2500	3.57	75.38
5100	4.54	78.71
5200	4.76	77.61
5300	4.96	79.16
5400	5.76	78.39
5500	5.75	77.54
5600	5.56	78.81
5700	5.74	75.63
5800	5.78	76.68
5900	5.63	76.52

# Results Summary

## Peak gain & Efficiency – D2

Frequency (MHz)	Peak Gain (dBi)	Efficiency (%)
2400	3.58	75.12
2450	3.65	76.27
2500	3.83	77.53
5100	4.49	75.86
5200	4.5	77.66
5300	4.72	76.37
5400	4.61	75.22
5500	4.96	78.95
5600	5.46	76.45
5700	5.39	77.18
5800	5.54	75.64
5900	5.52	77.45

## Peak gain & Efficiency – D3

Frequency (MHz)	Peak Gain (dBi)	Efficiency (%)
2400	3.51	75.33
2450	3.78	76.29
2500	3.44	75.81
5100	4.4	75.57
5200	5.47	76.71
5300	5.28	75.98
5400	5.58	78.39
5500	5.49	79.43
5600	4.91	75.61
5700	5.78	76.95
5800	5.42	76.07
5900	5.31	75.46

# Results Summary

## Peak gain & Efficiency – D4

Frequency (MHz)	Peak Gain (dBi)	Efficiency (%)
2400	3.54	75.78
2450	3.75	76.83
2500	3.59	76.75
5100	4.06	75.53
5200	4	76.95
5300	4.55	78.02
5400	5.11	76.21
5500	4.89	76.1
5600	5.48	75.96
5700	5.77	77.98
5800	5.32	75.68
5900	5.11	75.02

## Peak gain & Efficiency – 5G1

Frequency (MHz)	Peak Gain (dBi)	Efficiency (%)
5100	4.57	76.53
5200	4.66	77.34
5300	4.75	76.57
5400	5.4	77.45
5500	5.56	79.49
5600	5.26	75.99
5700	5.33	77.85
5800	5.59	76.38
5900	5.17	75.25



# Results Summary

## Peak gain & Efficiency – 5G2

Frequency (MHz)	Peak Gain (dBi)	Efficiency (%)
5100	4.55	75.99
5200	5.19	76.96
5300	4.93	77.66
5400	5.25	78.72
5500	5.09	76.52
5600	5.32	77.54
5700	5.53	79.33
5800	5.24	75.53
5900	5.88	77.51

## Peak gain & Efficiency – 6G1

Frequency (MHz)	Peak Gain (dBi)	Efficiency (%)
5800	4.5	75.47
5900	4.48	75.98
6000	5.26	77.3
6100	4.83	76.47
6200	4.77	77.34
6300	5.18	78.81
6400	5.31	79.08
6500	5.51	79.8
6600	5.02	80.64
6700	5.58	79.77
6800	5.71	77.67
6900	5.58	76.24
7000	5.52	75.65
7100	5.67	77.93
7200	5.45	78.08
7300	5.27	78.79
7400	5.37	77.78
7500	5.49	76.88

# Results Summary

## Peak gain & Efficiency – 6G2

Frequency (MHz)	Peak Gain (dBi)	Efficiency (%)
5800	5.27	75.95
5900	5.79	75.46
6000	5.29	78.38
6100	5.34	76.17
6200	5.89	77.32
6300	5.14	75.97
6400	5.04	77.21
6500	5.07	76.89
6600	5.34	77.33
6700	5.79	75.08
6800	5.56	78.53
6900	5.04	75.62
7000	5.72	79.89
7100	5.75	79.75
7200	5.85	80.35
7300	5.27	77.18
7400	5.72	78.08
7500	5.29	76.79

## Applicable Test Method

ETS-Lindgren AMS-8500 system is 3D fully anechoic chamber, it is applied to the “Conical Cut test method”, the detail description is described as below.

The Conical Cut method requires the ability of the Measurement Antenna to be physically rotated in the theta plane (overhead) of the EUT for implementations using a single Measurement Antenna, Eleven conical cuts are required to capture data at every 15 degrees from the EUT, with the top (0 degrees) and bottom (180 degrees) cuts not being measured. Typically, the EUT will remain affixed to a turntable during the entire measurement process. The Measurement Antenna will be positioned at a starting theta angle. The EUT will then be rotated around the full 360 degrees of phi rotation. The Measurement Antenna will then be positioned at the next theta angle, and the process repeated.

Test Date: Jan. 21, 2022

Test Personnel: PSJ

Test Software: ETS-Lindgren EMQuest

		$\theta$ -Axis	$\Phi$ -Axis
Passive	Step size	15°~165° step: 15°	0°~345° step: 15°
	N / M (Points)	12	24

## Test & System Description

a. Typical setup of ETS-Lindgren AMS-8500

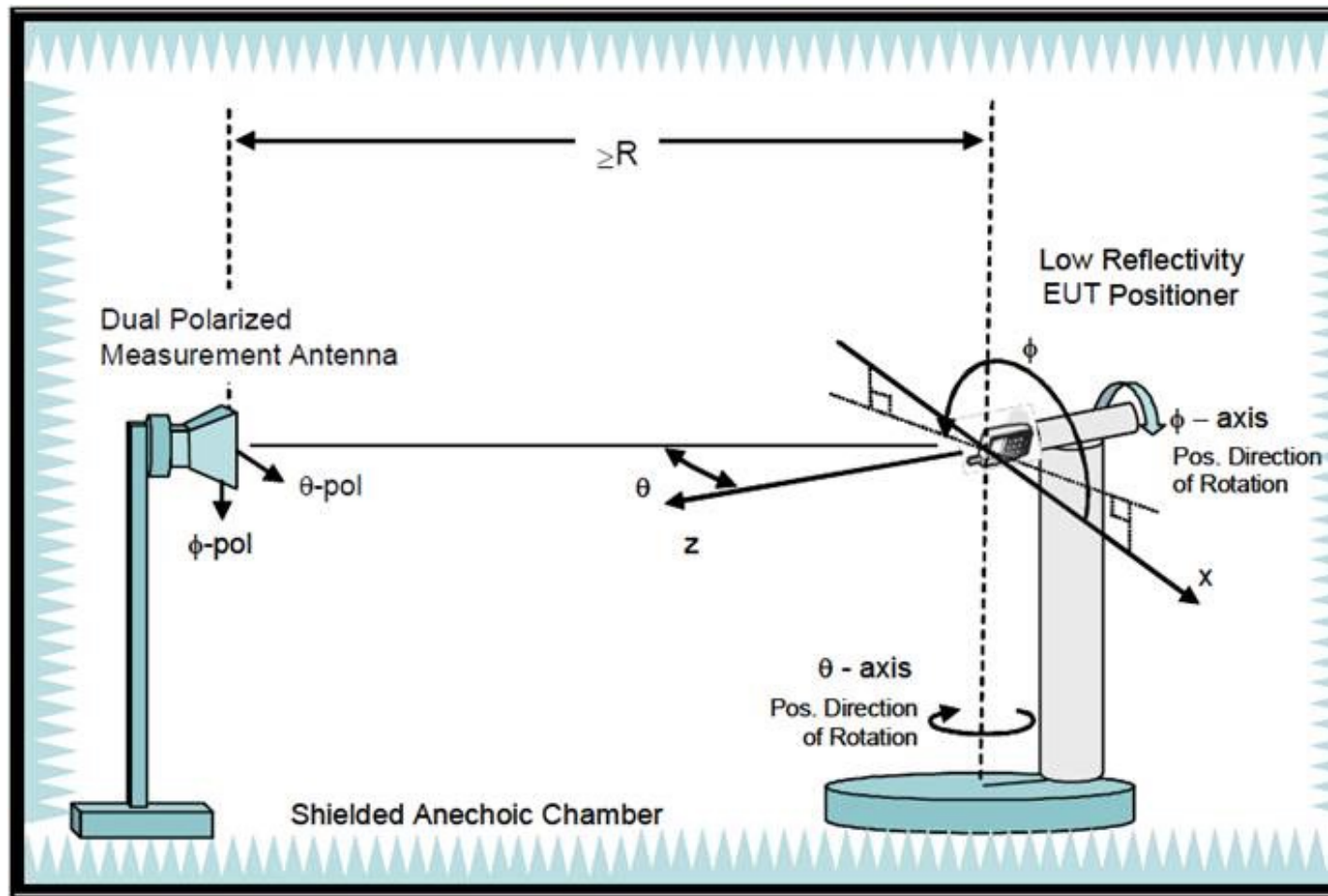

# Test Setup

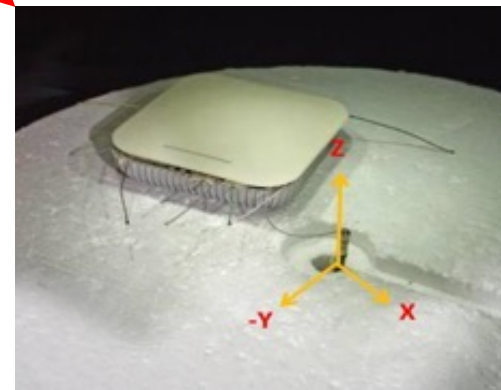
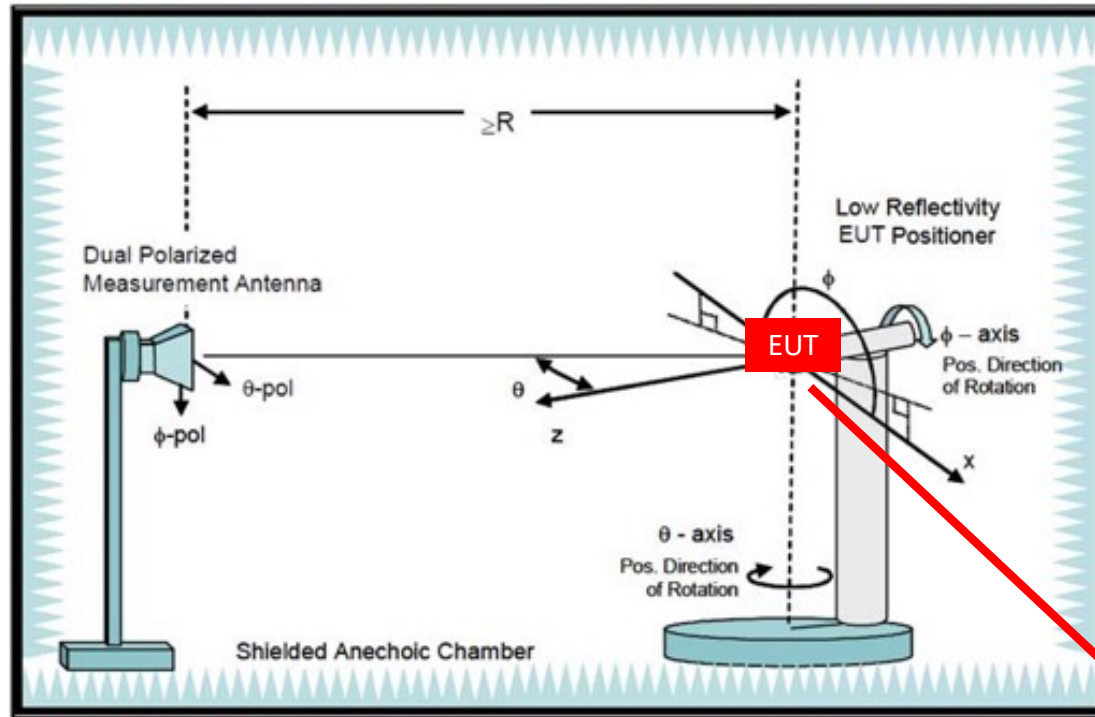

## Test & System Description

### a. Equipment List

<b><i>Equipment Description</i></b>	<b><i>Manufacturer</i></b>	<b><i>Identification no.</i></b>	<b><i>Current calibration date</i></b>	<b><i>Next calibration date</i></b>
Network analyzer	Agilent	E5071C	2022/01/06	2023/01/06
Measurement software	ETS-Lindgren	EMQuest	2021/03/03	2022/03/03
Multi axis positioning system(MAPSTM)	ETS-Lindgren	EMCO 2115	2021/03/03	2022/03/03
Multi axis positioning system(MAPSTM)	ETS-Lindgren	EMCO 2110	2021/03/03	2022/03/03
MAPSTM controller	ETS-Lindgren	EMCO 2090	2021/03/03	2022/03/03
Horn antenna	ETS-Lindgren	3164-10	2020/03/03	2022/03/03
Cable 40cm 18 GHz	Jmtt	201EH012010400	2021/04/07	2022/04/07
Cable 6m 18 GHz	Jmtt	201EH012016000	2021/04/07	2022/04/07
Cable 6m 18 GHz	Jmtt	201EH012016000	2021/04/07	2022/04/07
Cable 3.5m 18 GHz	Jmtt	201EH012013500	2021/04/07	2022/04/07
Cable 1.5m 18 GHz	Jmtt	201EH012011500	2021/04/07	2022/04/07