

FCC Radio Test Report

FCC ID: TVE-37146T064

This report concerns: Class II

Project No. : 1906C186A
Equipment : Secured Wireless Access Point
Brand Name : FORTINET
Test Model : FAP-321E
Series Model : FAP-321Exxxxxx, FortiAP 321Exxxxxx, FORTIAP-321Exxxxxx (where "x" can be used as "A-Z" or "0-9" or "-" or blank for software changes or marking purposes only)

Applicant : Fortinet, Inc.
Address : 899 Kifer Road, Sunnyvale, CA 94086 USA
Manufacturer : SHENZHEN TENDA TECHNOLOGY CO.,LTD
Address : 6-8 Floor, Tower E3, No. 1001, Zhongshanyuan Road, Nanshan District, Shenzhen, China. 518052

Date of Receipt : Jun. 28, 2019
Nov. 14, 2019

Date of Test : Jul. 01, 2019 ~ Oct. 10, 2019
Nov. 14, 2019 ~ Dec. 27, 2019

Issued Date : Jan. 23, 2020

Report Version : R01

Test Sample : Engineering Sample No.: DG19062851

Standard(s) : FCC Part15, Subpart E(15.407)
ANSI C63.10-2013
FCC KDB 789033 D02 General UNII Test Procedures New Rules v02r01
FCC KDB 662911 D01 Multiple Transmitter Output v02r01

The above equipment has been tested and found compliance with the requirement of the relative standards by BTL Inc.

Prepared by : Chay Cai

Approved by : Ethan Ma



Certificate #5123.02

Add: No.3, Jinshagang 1st Road, Shixia, Dalang Town,Dongguan, Guangdong, China.

Tel: +86-769-8318-3000

Web: www.newbtl.com

Declaration

BTL represents to the client that testing is done in accordance with standard procedures as applicable and that test instruments used has been calibrated with standards traceable to international standard(s) and/or national standard(s).

BTL's reports apply only to the specific samples tested under conditions. It is manufacture's responsibility to ensure that additional production units of this model are manufactured with the identical electrical and mechanical components. **BTL** shall have no liability for any declarations, inferences or generalizations drawn by the client or others from **BTL** issued reports.

The report must not be used by the client to claim product certification, approval, or endorsement by NVLAP, NIST, A2LA, or any agency of the U.S. Government.

This report is the confidential property of the client. As a mutual protection to the clients, the public and ourselves, the test report shall not be reproduced, except in full, without our written approval.

BTL's laboratory quality assurance procedures are in compliance with the **ISO/IEC 17025** requirements, and accredited by the conformity assessment authorities listed in this test report.

BTL is not responsible for the sampling stage, so the results only apply to the sample as received.

The information, data and test plan are provided by manufacturer which may affect the validity of results, so it is manufacturer's responsibility to ensure that the apparatus meets the essential requirements of applied standards and in all the possible configurations as representative of its intended use.

Limitation

For the use of the authority's logo is limited unless the Test Standard(s)/Scope(s)/Item(s) mentioned in this test report is (are) included in the conformity assessment authorities acceptance respective.

Please note that the measurement uncertainty is provided for informational purpose only and are not use in determining the Pass/Fail results.

Table of Contents**Page**

REPORT ISSUED HISTORY	6
1 . SUMMARY OF TEST RESULTS	7
1.1 TEST FACILITY	8
1.2 MEASUREMENT UNCERTAINTY	8
1.3 TEST ENVIRONMENT CONDITIONS	8
2 . GENERAL INFORMATION	9
2.1 GENERAL DESCRIPTION OF EUT	9
2.2 TEST MODES	13
2.3 PARAMETERS OF TEST SOFTWARE	18
2.4 DUTY CYCLE	21
2.5 BLOCK DIAGRAM SHOWING THE CONFIGURATION OF SYSTEM TESTED	23
2.6 SUPPORT UNITS	23
3 . AC POWER LINE CONDUCTED EMISSIONS TEST	24
3.1 LIMIT	24
3.2 TEST PROCEDURE	24
3.3 DEVIATION FROM TEST STANDARD	24
3.4 TEST SETUP	25
3.5 EUT OPERATION CONDITIONS	25
3.6 TEST RESULTS	25
4 . RADIATED EMISSIONS TEST	26
4.1 LIMIT	26
4.2 TEST PROCEDURE	27
4.3 DEVIATION FROM TEST STANDARD	27
4.4 TEST SETUP	28
4.5 EUT OPERATION CONDITIONS	29
4.6 TEST RESULTS - 9 KHZ to 30 MHZ	29
4.7 TEST RESULTS - 30 MHz TO 1000 MHz	29
4.8 TEST RESULTS - ABOVE 1000 MHz	29
5 . BANDWIDTH TEST	30
5.1 LIMIT	30
5.2 TEST PROCEDURE	30
5.3 TEST PROCEDURE	30

Table of Contents	Page
5.4 TEST SETUP	30
5.5 EUT OPERATION CONDITIONS	30
5.6 TEST RESULTS	30
6 . CONDUCTED OUTPUT POWER TEST	31
6.1 LIMIT	31
6.2 TEST PROCEDURE	31
6.3 DEVIATION FROM STANDARD	31
6.4 TEST SETUP	31
6.5 EUT OPERATION CONDITIONS	31
6.6 TEST RESULTS	31
7 . POWER SPECTRAL DENSITY TEST	32
7.1 LIMIT	32
7.2 TEST PROCEDURE	32
7.3 DEVIATION FROM STANDARD	32
7.4 TEST SETUP	32
7.5 EUT OPERATION CONDITIONS	32
7.6 TEST RESULTS	32
8 . FREQUENCY STABILITY MEASUREMENT	33
8.1 LIMIT	33
8.2 TEST PROCEDURE	33
8.3 DEVIATION FROM STANDARD	33
8.4 TEST SETUP	33
8.5 EUT OPERATION CONDITIONS	33
8.6 TEST RESULTS	33
9 . MEASUREMENT INSTRUMENTS LIST	34
10 . EUT TEST PHOTOS	36
APPENDIX A - AC POWER LINE CONDUCTED EMISSIONS	40
APPENDIX B - RADIATED EMISSION - 9 KHZ TO 30 MHZ	43
APPENDIX C - RADIATED EMISSION - 30 MHZ TO 1 GHZ	48
APPENDIX D - RADIATED EMISSION - ABOVE 1000 MHZ	51
APPENDIX E - BANDWIDTH	228

Table of Contents**Page**

APPENDIX F - CONDUCTED OUTPUT POWER	246
APPENDIX G - POWER SPECTRAL DENSITY	291
APPENDIX H - FREQUENCY STABILITY	329

REPORT ISSUED HISTORY

Report Version	Description	Issued Date
R00	Compared with the previous report (BTL-FCCP-3-1906C186),added the description and test data of UNII-2A & UNII-2C.	Jan. 09, 2020
R01	Updated the Description of Section 2.2.	Jan. 23, 2020

1. SUMMARY OF TEST RESULTS

Test procedures according to the technical standard(s):

FCC Part15, Subpart E(15.407)				
Standard(s) Section	Test Item	Test Result	Judgement	Remark
15.207 15.407(b)	AC Power Line Conducted Emissions	APPENDIX A	PASS	-----
15.407(b) 15.205(a) 15.209(a)	Radiated Emissions	APPENDIX B APPENDIX C APPENDIX D	PASS	-----
15.407(a) 15.407(e)	Spectrum Bandwidth	APPENDIX E	PASS	-----
15.407(a)	Conducted Output Power	APPENDIX F	PASS	-----
15.407(a)	Power Spectral Density	APPENDIX G	PASS	-----
15.407(g)	Frequency Stability	APPENDIX H	PASS	-----
15.203	Antenna Requirements	-----	PASS	NOTE (2)
15.407(c)	Automatically Discontinue Transmission	-----	PASS	NOTE (3)

Note:

- (1) "N/A" denotes test is not applicable in this test report.
- (2) The device what use a permanently attached antenna were considered sufficient to comply with the provisions of 15.203.
- (3) During no any information transmission, the EUT can automatically discontinue transmission and become standby mode for power saving. the EUT can detect the controlling signal of ACK message transmitting from remote device and verify whether it shall resend or discontinue transmission.
- (4) For UNII-1 this device was functioned as a
 Access point device Client device

1.1 TEST FACILITY

The test facilities used to collect the test data in this report is at the location of No.3,Jinshagang 1st Road, Shixia, Dalang Town, Dongguan, Guangdong, China.
 BTL's Test Firm Registration Number for FCC: 357015
 BTL's Designation Number for FCC: CN1240

1.2 MEASUREMENT UNCERTAINTY

ISO/IEC 17025 requires that an estimate of the measurement uncertainties associated with the emissions test results be included in the report. The measurement uncertainties given below are based on a 95% confidence level (based on a coverage factor (k=2))
 The BTL measurement uncertainty as below table:

A. AC power line conducted emissions test:

Test Site	Method	Measurement Frequency Range	U, (dB)
DG-C02	CISPR	150kHz ~ 30MHz	2.60

B. Radiated emissions test:

Test Site	Method	Measurement Frequency Range	Ant. H / V	U, (dB)
DG-CB03	CISPR	9kHz ~ 30MHz	V	3.79
		9kHz ~ 30MHz	H	3.57
		30MHz ~ 200MHz	V	4.88
		30MHz ~ 200MHz	H	4.14
		200MHz ~ 1,000MHz	V	4.62
		200MHz ~ 1,000MHz	H	4.80
		1GHz ~ 6GHz	-	4.58
		6GHz ~ 18GHz	-	5.18
		18GHz ~ 26.5GHz	-	3.62
		26.5GHz ~ 40GHz	-	4.00

Note: Unless specifically mentioned, the uncertainty of measurement has not been taken into account to declare the compliance or non-compliance to the specification.

1.3 TEST ENVIRONMENT CONDITIONS

Test Item	Temperature	Humidity	Test Voltage	Tested By
AC Power Line Conducted Emissions	25°C	53%	AC 120V/60Hz	Laughing Zhang
Radiated Emissions-9K-30MHz	25°C	60%	AC 120V/60Hz	Laughing Zhang
Radiated Emissions-30 MHz to 1GHz	24°C	68%	AC 120V/60Hz	Laughing Zhang
Radiated Emissions-Above 1000 MHz	24°C	68%	AC 120V/60Hz	Laughing Zhang
Spectrum Bandwidth	24°C	65%	AC 120V/60Hz	Jonas Chen
Conducted Output Power	24°C	65%	AC 120V/60Hz	Laughing Zhang
Power Spectral Density	24°C	65%	AC 120V/60Hz	Jonas Chen
Frequency Stability	Normal & Extreme	65%	Normal & Extreme	Jonas Chen

2. GENERAL INFORMATION

2.1 GENERAL DESCRIPTION OF EUT

Equipment	Secured Wireless Access Point
Brand Name	FORTINET
Test Model	FAP-321E
Series Model	FAP-321Exxxxxx, FortiAP 321Exxxxxx, FORTIAP-321Exxxxxx (where "x" can be used as "A-Z" or "0-9" or "-" or blank for software changes or marking purposes only)
Model Difference(s)	Only differ in model name.
Power Source	1# DC voltage supplied from AC/DC adapter. Model: WA-30J12R 2# DC voltage supplied from POE adapter.
Power Rating	1# I/P: 100-240V~ 50-60Hz 0.9A Max. O/P: 12V --- 2.5A 2# DC 48V
Operation Frequency	UNII-1: 5150 MHz~5250 MHz UNII-2A: 5250 MHz~5350 MHz UNII-2C: 5470 MHz~5725 MHz UNII-3: 5725 MHz~5850 MHz
Modulation Type	OFDM
Bit Rate of Transmitter	Up to 1300 Mbps
Maximum Conducted Output Power for UNII-1 Non Beamforming	IEEE 802.11a: 25.42 dBm (0.3483 W) IEEE 802.11n (HT20): 23.59 dBm (0.2286 W) IEEE 802.11n (HT40): 23.68 dBm (0.2333 W) IEEE 802.11ac (VHT20): 23.66 dBm (0.2323 W) IEEE 802.11ac (VHT40): 23.76 dBm (0.2377 W) IEEE 802.11ac (VHT80): 20.77 dBm (0.1194 W)
Maximum Conducted Output Power for UNII-2A Non Beamforming	IEEE 802.11a: 21.16 dBm (0.1306 W) IEEE 802.11n (HT20): 20.69 dBm (0.1172 W) IEEE 802.11n (HT40): 23.86 dBm (0.2432 W) IEEE 802.11ac (VHT20): 20.80 dBm (0.1202 W) IEEE 802.11ac (VHT40): 23.90 dBm (0.2455 W) IEEE 802.11ac (VHT80): 22.79 dBm (0.1901 W)
Maximum Conducted Output Power for UNII-2C Non Beamforming	IEEE 802.11a: 23.10 dBm (0.2042 W) IEEE 802.11n (HT20): 22.44 dBm (0.1754 W) IEEE 802.11n (HT40): 23.86 dBm (0.2432 W) IEEE 802.11ac (VHT20): 22.57 dBm (0.1807 W) IEEE 802.11ac (VHT40): 23.90 dBm (0.2455 W) IEEE 802.11ac (VHT80): 23.78 dBm (0.2388W)
Maximum Conducted Output Power for UNII-3 Non Beamforming	IEEE 802.11a: 17.97 dBm (0.0627 W) IEEE 802.11n (HT20): 29.84 dBm (0.9638 W) IEEE 802.11n (HT40): 29.04 dBm (0.8017 W) IEEE 802.11ac (VHT20): 29.96 dBm (0.9908 W) IEEE 802.11ac (VHT40): 29.05 dBm (0.8035 W) IEEE 802.11ac (VHT80): 23.30 dBm (0.2138 W)

Maximum Conducted Output Power for UNII-1 Beamforming	IEEE 802.11n (HT20): 23.42 dBm (0.2198 W) IEEE 802.11n (HT40): 23.60 dBm (0.2291 W) IEEE 802.11ac (VHT20): 23.42 dBm (0.2198 W) IEEE 802.11ac (VHT40): 23.63 dBm (0.2307 W) IEEE 802.11ac (VHT80): 20.72 dBm (0.1180 W)
Maximum Conducted Output Power for UNII-2A Beamforming	IEEE 802.11n (HT20): 20.26 dBm (0.1062 W) IEEE 802.11n (HT40): 20.37 dBm (0.1089 W) IEEE 802.11ac (VHT20): 20.31 dBm (0.1074 W) IEEE 802.11ac (VHT40): 20.41 dBm (0.1099 W) IEEE 802.11ac (VHT80): 20.39 dBm (0.1094 W)
Maximum Conducted Output Power for UNII-2C Beamforming	IEEE 802.11n (HT20): 21.46 dBm (0.1400 W) IEEE 802.11n (HT40): 21.24 dBm (0.1330 W) IEEE 802.11ac (VHT20): 21.49 dBm (0.1409 W) IEEE 802.11ac (VHT40): 21.29 dBm (0.1346 W) IEEE 802.11ac (VHT80): 21.47 dBm (0.1403 W)
Maximum Conducted Output Power for UNII-3 Beamforming	IEEE 802.11n (HT20): 27.45 dBm (0.5559 W) IEEE 802.11n (HT40): 27.48 dBm (0.5598 W) IEEE 802.11ac (VHT20): 27.49 dBm (0.5610 W) IEEE 802.11ac (VHT40): 27.49 dBm (0.5610 W) IEEE 802.11ac (VHT80): 23.08 dBm (0.2032 W)

Note:

1. For a more detailed features description, please refer to the manufacturer's specifications or the user's manual.

2. Channel List:

IEEE 802.11a IEEE 802.11n (HT20) IEEE 802.11ac (VHT20)		IEEE 802.11n (HT40) IEEE 802.11ac (VHT40)		IEEE 802.11ac (VHT80)	
UNII-1		UNII-1		UNII-1	
Channel	Frequency (MHz)	Channel	Frequency (MHz)	Channel	Frequency (MHz)
36	5180	38	5190	42	5210
40	5200	46	5230		
44	5220				
48	5240				

IEEE 802.11a IEEE 802.11n (HT20) IEEE 802.11ac (VHT20)		IEEE 802.11n (HT40) IEEE 802.11ac (VHT40)		IEEE 802.11ac (VHT80)	
UNII-2A		UNII-2A		UNII-2A	
Channel	Frequency (MHz)	Channel	Frequency (MHz)	Channel	Frequency (MHz)
52	5260	54	5270	58	5290
56	5280	62	5310		
60	5300				
64	5320				

IEEE 802.11a IEEE 802.11n (HT20) IEEE 802.11ac (VHT20)		IEEE 802.11n (HT40) IEEE 802.11ac (VHT40)		IEEE 802.11ac (VHT80)	
UNII-2C		UNII-2C		UNII-2C	
Channel	Frequency (MHz)	Channel	Frequency (MHz)	Channel	Frequency (MHz)
100	5500	102	5510	106	5530
104	5520	110	5550	122	5610
108	5540	118	5590	138	5690
112	5560	126	5630		
116	5580	134	5670		
120	5600	142	5710		
124	5620				
128	5640				
132	5660				
136	5680				
140	5700				
144	5720				

IEEE 802.11a IEEE 802.11n (HT20) IEEE 802.11ac (VHT20)		IEEE 802.11n (HT40) IEEE 802.11ac (VHT40)		IEEE 802.11ac (VHT80)	
UNII-3		UNII-3		UNII-3	
Channel	Frequency (MHz)	Channel	Frequency (MHz)	Channel	Frequency (MHz)
149	5745	151	5755	155	5775
153	5765	159	5795		
157	5785				
161	5805				
165	5825				

3. Antenna Specification:

Ant.	Brand	Model Name	Antenna Type	Connector	Gain (dBi)
1	Tenda	N/A	Internal	IPEX	4.0
2	Tenda	N/A	Internal	IPEX	4.0
3	Tenda	N/A	Internal	IPEX	4.0

Note: This EUT supports CDD, and all antennas have the same gain,

- (1) For Non Beamforming function, Directional gain= $G_{ANT} + \text{Array Gain}$,
 For output power measurements, Array Gain=0, so, Directional gain=4.0
 For power spectral density measurements, Array Gain= $10\log(N_{ANT}/N_{SS})$ dB
 Directional gain= $4.0 + 10\log(3/1) = 8.77$.
 So, the UNII-1 power density limit is $17 - 8.77 + 6 = 14.23$
 the UNII-2A&UNII-2C power density limit is $11 - 8.77 + 6 = 8.23$
 the UNII-3 power density limit is $30 - 8.77 + 6 = 27.23$

- (2) For Beamforming function, Beamforming gain: 4.5dB, so Directional gain= $4.0 + 4.5 = 8.50$
 Then, the UNII-2A&UNII-2C output Power limit is $24 - 8.50 + 6 = 21.50$
 the UNII-1&UNII-3 output Power limit is $30 - 8.50 + 6 = 27.50$

4. Table for Antenna Configuration:

For Non Beamforming:

Operating Mode	TX Mode	3TX
IEEE 802.11a		V (Ant. 1 + Ant. 2 + Ant. 3)
IEEE 802.11n (HT20)		V (Ant. 1 + Ant. 2 + Ant. 3)
IEEE 802.11n (HT40)		V (Ant. 1 + Ant. 2 + Ant. 3)
IEEE 802.11ac (VHT20)		V (Ant. 1 + Ant. 2 + Ant. 3)
IEEE 802.11ac (VHT40)		V (Ant. 1 + Ant. 2 + Ant. 3)
IEEE 802.11ac (VHT80)		V (Ant. 1 + Ant. 2 + Ant. 3)

For Beamforming:

Operating Mode	TX Mode	3TX
IEEE 802.11n (HT20)		V (Ant. 1 + Ant. 2 + Ant. 3)
IEEE 802.11n (HT40)		V (Ant. 1 + Ant. 2 + Ant. 3)
IEEE 802.11ac (VHT20)		V (Ant. 1 + Ant. 2 + Ant. 3)
IEEE 802.11ac (VHT40)		V (Ant. 1 + Ant. 2 + Ant. 3)
IEEE 802.11ac (VHT80)		V (Ant. 1 + Ant. 2 + Ant. 3)

2.2 TEST MODES

The test system was pre-tested based on the consideration of all possible combinations of EUT operation mode.

Pretest Mode	Description
Mode 1	TX A Mode / CH36, CH40, CH48 (UNII-1)
Mode 2	TX N (HT20) Mode / CH36, CH40, CH48 (UNII-1)
Mode 3	TX N (HT40) Mode / CH38, CH46 (UNII-1)
Mode 4	TX AC (VHT20) Mode / CH36, CH40, CH48 (UNII-1)
Mode 5	TX AC (VHT40) Mode / CH38, CH46 (UNII-1)
Mode 6	TX AC (VHT80) Mode / CH42 (UNII-1)
Mode 7	TX A Mode / CH52, CH60, CH64 (UNII-2A)
Mode 8	TX N (HT20) Mode / CH52, CH60, CH64 (UNII-2A)
Mode 9	TX N (HT40) Mode / CH54, CH62 (UNII-2A)
Mode 10	TX AC (VHT20) Mode / CH52, CH60, CH64 (UNII-2A)
Mode 11	TX AC (VHT40) Mode / CH54, CH62 (UNII-2A)
Mode 12	TX AC (VHT80) Mode / CH58 (UNII-2A)
Mode 13	TX A Mode / CH100, CH116, CH140, CH144 (UNII-2C)
Mode 14	TX N (HT20) Mode / CH100, CH116, CH140, CH144 (UNII-2C)
Mode 15	TX N (HT40) Mode / CH102, CH110, CH134, CH142 (UNII-2C)
Mode 16	TX AC (VHT20) Mode / CH100, CH116, CH140, CH144 (UNII-2C)
Mode 17	TX AC (VHT40) Mode / CH102, CH110, CH134, CH142 (UNII-2C)
Mode 18	TX AC (VHT80) Mode / CH106, CH122, CH138 (UNII-2C)
Mode 19	TX A Mode / CH144, CH149,CH157,CH165 (UNII-3)
Mode 20	TX N (HT20) Mode / CH144, CH149,CH157,CH165 (UNII-3)
Mode 21	TX N (HT40) Mode / CH142, CH151,CH159 (UNII-3)
Mode 22	TX AC (VHT20) Mode / CH144, CH149,CH157,CH165 (UNII-3)
Mode 23	TX AC (VHT40) Mode / CH142, CH151,CH159 (UNII-3)
Mode 24	TX AC (VHT80) Mode / CH138, CH155 (UNII-3)
Mode 25	TX AC(VHT20) Mode / CH165 (UNII-3)

Following mode(s) was (were) found to be the worst case(s) and selected for the final test.

AC power line conducted emissions test	
Final Test Mode	Description
Mode 25	TX AC(VHT20) Mode / CH165 (UNII-3)

Radiated emissions test - Below 1GHz	
Final Test Mode	Description
Mode 25	TX AC(VHT20) Mode / CH165 (UNII-3)

Radiated emissions test - Above 1GHz	
Final Test Mode	Description
Mode 1	TX A Mode / CH36, CH40, CH48 (UNII-1)
Mode 4	TX AC (VHT20) Mode / CH36, CH40, CH48 (UNII-1)
Mode 5	TX AC (VHT40) Mode / CH38, CH46 (UNII-1)
Mode 6	TX AC (VHT80) Mode / CH42 (UNII-1)
Mode 7	TX A Mode / CH52, CH60, CH64 (UNII-2A)
Mode 10	TX AC (VHT20) Mode / CH52, CH60, CH64 (UNII-2A)
Mode 11	TX AC (VHT40) Mode / CH54, CH62 (UNII-2A)
Mode 12	TX AC (VHT80) Mode / CH58 (UNII-2A)
Mode 13	TX A Mode / CH100, CH116, CH140, CH144 (UNII-2C)
Mode 16	TX AC (VHT20) Mode / CH100, CH116, CH140, CH144 (UNII-2C)
Mode 17	TX AC (VHT40) Mode / CH102, CH110, CH134, CH142 (UNII-2C)
Mode 18	TX AC (VHT80) Mode / CH106, CH122, CH138 (UNII-2C)
Mode 19	TX A Mode / CH144, CH149,CH157,CH165 (UNII-3)
Mode 22	TX AC (VHT20) Mode / CH144, CH149,CH157,CH165 (UNII-3)
Mode 23	TX AC (VHT40) Mode / CH142, CH151,CH159 (UNII-3)
Mode 24	TX AC (VHT80) Mode / CH138, CH155 (UNII-3)

Conducted Output Power and Bandwidth test for Non Beamforming	
Final Test Mode	Description
Mode 1	TX A Mode / CH36, CH40, CH48 (UNII-1)
Mode 2	TX N (HT20) Mode / CH36, CH40, CH48 (UNII-1)
Mode 3	TX N (HT40) Mode / CH38, CH46 (UNII-1)
Mode 4	TX AC (VHT20) Mode / CH36, CH40, CH48 (UNII-1)
Mode 5	TX AC (VHT40) Mode / CH38, CH46 (UNII-1)
Mode 6	TX AC (VHT80) Mode / CH42 (UNII-1)
Mode 7	TX A Mode / CH52, CH60, CH64 (UNII-2A)
Mode 8	TX N (HT20) Mode / CH52, CH60, CH64 (UNII-2A)
Mode 9	TX N (HT40) Mode / CH54, CH62 (UNII-2A)
Mode 10	TX AC (VHT20) Mode / CH52, CH60, CH64 (UNII-2A)
Mode 11	TX AC (VHT40) Mode / CH54, CH62 (UNII-2A)
Mode 12	TX AC (VHT80) Mode / CH58 (UNII-2A)
Mode 13	TX A Mode / CH100, CH116, CH140, CH144 (UNII-2C)
Mode 14	TX N (HT20) Mode / CH100, CH116, CH140, CH144 (UNII-2C)
Mode 15	TX N (HT40) Mode / CH102, CH110, CH134, CH142 (UNII-2C)
Mode 16	TX AC (VHT20) Mode / CH100, CH116, CH140, CH144 (UNII-2C)
Mode 17	TX AC (VHT40) Mode / CH102, CH110, CH134, CH142 (UNII-2C)
Mode 18	TX AC (VHT80) Mode / CH106, CH122, CH138 (UNII-2C)
Mode 19	TX A Mode / CH144, CH149,CH157,CH165 (UNII-3)
Mode 20	TX N (HT20) Mode / CH144, CH149,CH157,CH165 (UNII-3)
Mode 21	TX N (HT40) Mode / CH142, CH151,CH159 (UNII-3)
Mode 22	TX AC (VHT20) Mode / CH144, CH149,CH157,CH165 (UNII-3)
Mode 23	TX AC (VHT40) Mode / CH142, CH151,CH159 (UNII-3)
Mode 24	TX AC (VHT80) Mode / CH138, CH155 (UNII-3)

Conducted Output Power test for Beamforming	
Final Test Mode	Description
Mode 2	TX N (HT20) Mode / CH36, CH40, CH48 (UNII-1)
Mode 3	TX N (HT40) Mode / CH38, CH46 (UNII-1)
Mode 4	TX AC (VHT20) Mode / CH36, CH40, CH48 (UNII-1)
Mode 5	TX AC (VHT40) Mode / CH38, CH46 (UNII-1)
Mode 6	TX AC (VHT80) Mode / CH42 (UNII-1)
Mode 8	TX N (HT20) Mode / CH52, CH60, CH64 (UNII-2A)
Mode 9	TX N (HT40) Mode / CH54, CH62 (UNII-2A)
Mode 10	TX AC (VHT20) Mode / CH52, CH60, CH64 (UNII-2A)
Mode 11	TX AC (VHT40) Mode / CH54, CH62 (UNII-2A)
Mode 12	TX AC (VHT80) Mode / CH58 (UNII-2A)
Mode 14	TX N (HT20) Mode / CH100, CH116, CH140, CH144 (UNII-2C)
Mode 15	TX N (HT40) Mode / CH102, CH110, CH134, CH142 (UNII-2C)
Mode 16	TX AC (VHT20) Mode / CH100, CH116, CH140, CH144 (UNII-2C)
Mode 17	TX AC (VHT40) Mode / CH102, CH110, CH134, CH142 (UNII-2C)
Mode 18	TX AC (VHT80) Mode / CH106, CH122, CH138 (UNII-2C)
Mode 20	TX N (HT20) Mode / CH144, CH149,CH157,CH165 (UNII-3)
Mode 21	TX N (HT40) Mode / CH142, CH151,CH159 (UNII-3)
Mode 22	TX AC (VHT20) Mode / CH144, CH149,CH157,CH165 (UNII-3)
Mode 23	TX AC (VHT40) Mode / CH142, CH151,CH159 (UNII-3)
Mode 24	TX AC (VHT80) Mode / CH138, CH155 (UNII-3)

Conducted test	
Test Mode	Description
Mode 1	TX A Mode / CH36, CH40, CH48 (UNII-1)
Mode 4	TX AC (VHT20) Mode / CH36, CH40, CH48 (UNII-1)
Mode 5	TX AC (VHT40) Mode / CH38, CH46 (UNII-1)
Mode 6	TX AC (VHT80) Mode / CH42 (UNII-1)
Mode 7	TX A Mode / CH52, CH60, CH64 (UNII-2A)
Mode 10	TX AC (VHT20) Mode / CH52, CH60, CH64 (UNII-2A)
Mode 11	TX AC (VHT40) Mode / CH54, CH62 (UNII-2A)
Mode 12	TX AC (VHT80) Mode / CH58 (UNII-2A)
Mode 13	TX A Mode / CH100, CH116, CH140, CH144 (UNII-2C)
Mode 16	TX AC (VHT20) Mode / CH100, CH116, CH140, CH144 (UNII-2C)
Mode 17	TX AC (VHT40) Mode / CH102, CH110, CH134, CH142 (UNII-2C)
Mode 18	TX AC (VHT80) Mode / CH106, CH122, CH138 (UNII-2C)
Mode 19	TX A Mode / CH144, CH149,CH157,CH165 (UNII-3)
Mode 22	TX AC (VHT20) Mode / CH144, CH149,CH157,CH165 (UNII-3)
Mode 23	TX AC (VHT40) Mode / CH142, CH151,CH159 (UNII-3)
Mode 24	TX AC (VHT80) Mode / CH138, CH155 (UNII-3)

Note:

- (1) For radiated emission below 1 GHz test, the IEEE 802.11ac20 channel 165 is found to be the worst case and recorded.
- (2) For radiated emission above 1 GHz test, 1GHz~26.5GHz and 26.5GHz~40GHz have been pre-tested and in this report only recorded the worst case. The remaining spurious points are all below the limit value of 20dB.
- (3) The measurements for Power were tested, the worst case were IEEE 802.11a mode, IEEE 802.11ac(VHT20) mode, IEEE 802.11ac(VHT40) mode, IEEE 802.11ac(VHT80), only worst case were documented for other test items except Bandwidth.
- (4) The measurements for Power were tested, the worst case were Non Beamforming, only worst case were documented for other test items.
- (5) The measurements for AC Power Line Conducted Emissions, Duty Cycle and Radiated Emission below 1 GHz were tested and found that the test data were the same as original.
- (6) For Bandwidth, both Ant.1 and Ant.2 were tested and in this report only recorded the worst case.

2.3 PARAMETERS OF TEST SOFTWARE

Non Beamforming

UNII-1			
Test Software	QRCT v3.0.187.0		
Test Frequency (MHz)	5180	5200	5240
IEEE 802.11a	19.5	19.5	19.5
IEEE 802.11n (HT20)	19	19	19
IEEE 802.11ac (VHT20)	19	19	19
Test Frequency (MHz)	5190	5230	
IEEE 802.11n (HT40)	19	19	
IEEE 802.11ac (VHT40)	19	19	
Test Frequency (MHz)	5210		
IEEE 802.11ac (VHT80)	16		

UNII-2A			
Test Software	QRCT v3.0.187.0		
Test Frequency (MHz)	5260	5300	5320
IEEE 802.11a	15.5	15.5	15.5
IEEE 802.11n (HT20)	15.5	15.5	15.5
IEEE 802.11ac (VHT20)	15.5	15.5	15.5
Test Frequency (MHz)	5270	5310	
IEEE 802.11n (HT40)	18.5	18	
IEEE 802.11ac (VHT40)	18.5	18	
Test Frequency (MHz)	5290		
IEEE 802.11ac (VHT80)	17		

UNII-2C				
Test Software	QRCT v3.0.187.0			
Test Frequency (MHz)	5500	5580	5700	5720
IEEE 802.11a	16.5	17	15.5	12.5
IEEE 802.11n (HT20)	16.5	17	15.5	13
IEEE 802.11ac (VHT20)	16.5	17	15.5	13
Test Frequency (MHz)	5510	5550	5670	5710
IEEE 802.11n (HT40)	18	18	18	15.5
IEEE 802.11ac (VHT40)	18	18	18	15.5
Test Frequency (MHz)	5530	5610	5690	
IEEE 802.11ac (VHT80)	17	18	18.5	

UNII-3				
Test Software	QRCT v3.0.187.0			
Test Frequency (MHz)	5720	5745	5785	5825
IEEE 802.11a	12.5	13	13	12
IEEE 802.11n (HT20)	13	25.5	25	27
IEEE 802.11ac (VHT20)	13	25.5	25	27
Test Frequency (MHz)	5710	5755	5795	
IEEE 802.11n (HT40)	15.5	24	25	
IEEE 802.11ac (VHT40)	15.5	24	25	
Test Frequency (MHz)	5690	5775		
IEEE 802.11ac (VHT80)	18.5	19		

Beamforming

UNII-1				
Test Software	QRCT v3.0.187.0			
Test Frequency (MHz)	5180	5200	5240	
IEEE 802.11n (HT20)	19	19	19	
IEEE 802.11ac (VHT20)	19	19	19	
Test Frequency (MHz)	5190	5230		
IEEE 802.11n (HT40)	19	19		
IEEE 802.11ac (VHT40)	19	19		
Test Frequency (MHz)	5210			
IEEE 802.11ac (VHT80)	16			

UNII-2A				
Test Software	QRCT v3.0.187.0			
Test Frequency (MHz)	5260	5300	5320	
IEEE 802.11n (HT20)	15	15	15	
IEEE 802.11ac (VHT20)	15	15	15	
Test Frequency (MHz)	5270	5310		
IEEE 802.11n (HT40)	15	15		
IEEE 802.11ac (VHT40)	15	15		
Test Frequency (MHz)	5290			
IEEE 802.11ac (VHT80)	15			

UNII-2C				
Test Software	QRCT v3.0.187.0			
Test Frequency (MHz)	5500	5580	5700	5720
IEEE 802.11n (HT20)	16	16	15	12
IEEE 802.11ac (VHT20)	16	16	15	12
Test Frequency (MHz)	5510	5550	5670	5710
IEEE 802.11n (HT40)	14.5	15.5	15.5	15
IEEE 802.11ac (VHT40)	14.5	15.5	15.5	15
Test Frequency (MHz)	5530	5610	5690	
IEEE 802.11ac (VHT80)	15.5	16	15.5	

UNII-3				
Test Software	QRCT v3.0.187.0			
Test Frequency (MHz)	5720	5745	5785	5825
IEEE 802.11n (HT20)	12	23.5	23.5	23.5
IEEE 802.11ac (VHT20)	12	23.5	22.5	23.5
Test Frequency (MHz)	5710	5755	5795	
IEEE 802.11n (HT40)	15	23.5	23.5	
IEEE 802.11ac (VHT40)	15	23.5	23.5	
Test Frequency (MHz)	5690	5775		
IEEE 802.11ac (VHT80)	15.5	19		

2.4 DUTY CYCLE

If duty cycle is $\geq 98\%$, duty factor is not required.
 If duty cycle is $< 98\%$, duty factor shall be considered.
 The output power = measured power + duty factor.

IEEE 802.11a

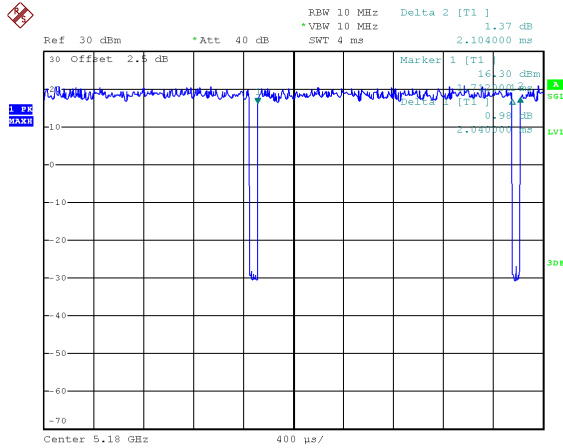

Date: 20.JUL.2019 14:01:00

Duty cycle = 2.040 ms / 2.104 ms = 96.96%
 Duty Factor = $10 \log(1 / \text{Duty cycle}) = 0.13$

IEEE 802.11n (HT20)

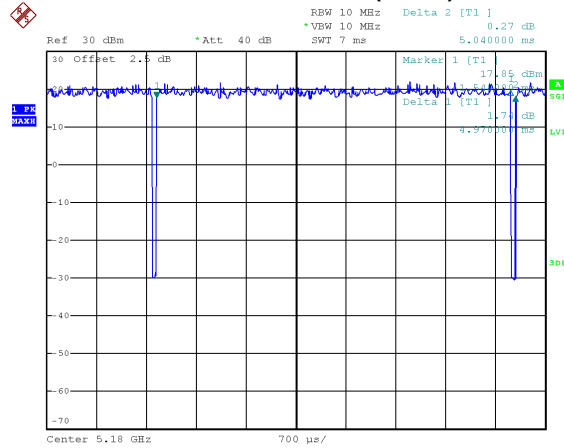

Date: 20.JUL.2019 14:37:24

Duty cycle = 4.970 ms / 5.040 ms = 98.61%
 Duty Factor = $10 \log(1 / \text{Duty cycle}) = 0.00$

IEEE 802.11n (HT40)

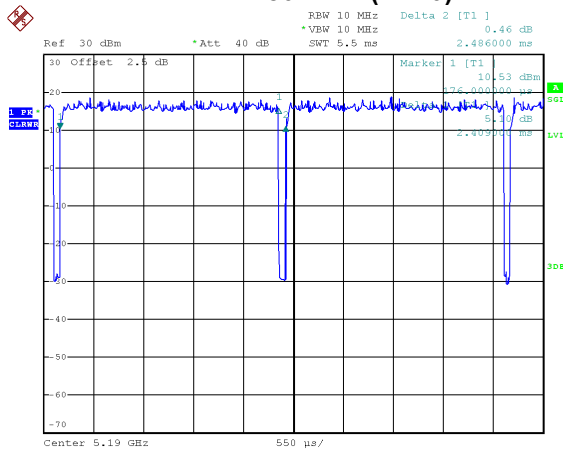

Date: 20.JUL.2019 14:38:09

Duty cycle = 2.409 ms / 2.486 ms = 96.90%
 Duty Factor = $10 \log(1 / \text{Duty cycle}) = 0.14$

IEEE 802.11ac (VHT20)

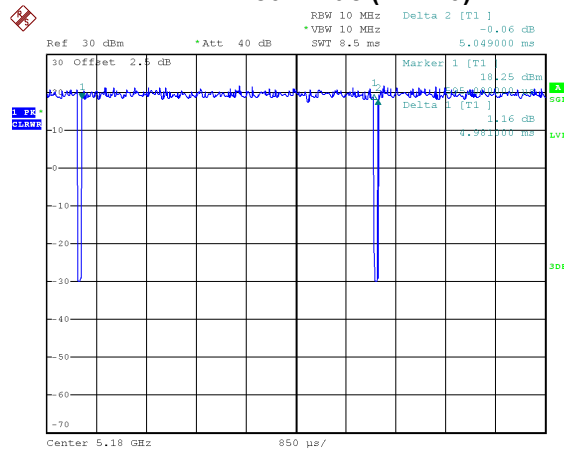

Date: 20.JUL.2019 14:39:00

Duty cycle = 4.981 ms / 5.049 ms = 98.65%
 Duty Factor = $10 \log(1 / \text{Duty cycle}) = 0.00$

IEEE 802.11ac (VHT40)

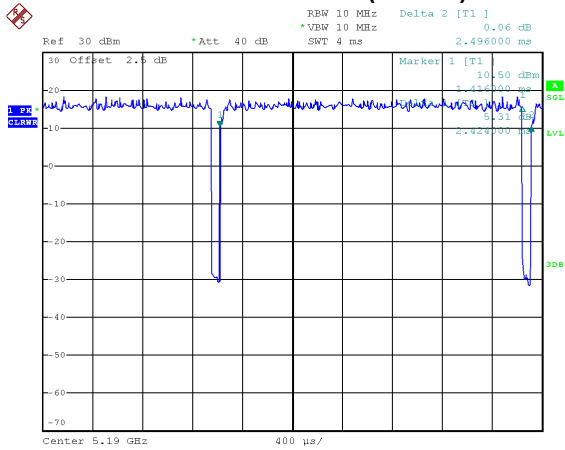

IEEE 802.11ac (VHT80)

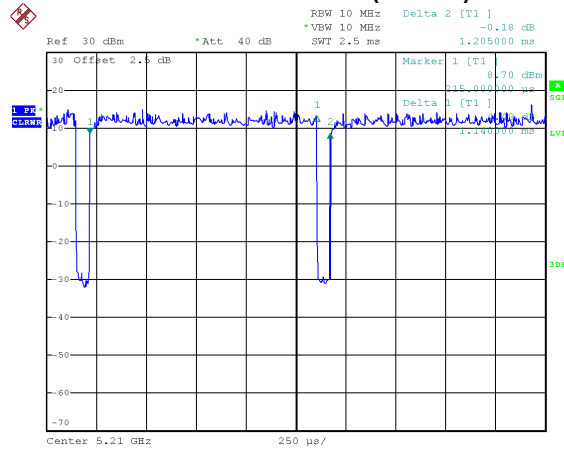

Date: 20.JUL.2019 14:39:34

Date: 20.JUL.2019 14:40:22

Duty cycle = 2.424 ms / 2.496 ms = 97.12%
 Duty Factor = 10 log(1 / Duty cycle) = 0.13

Duty cycle = 1.140 ms / 1.205 ms = 94.61%
 Duty Factor = 10 log(1 / Duty cycle) = 0.24

NOTE:

For IEEE 802.11a, IEEE 802.11n (HT20) and IEEE 802.11ac (VHT20):

For radiated emissions frequency above 1 GHz, the resolution bandwidth of test receiver/spectrum analyzer is 1 MHz and the video bandwidth is 1 kHz (Duty cycle < 98%).

For IEEE 802.11n (HT40) and IEEE 802.11ac (VHT40):

For radiated emissions frequency above 1 GHz, the resolution bandwidth of test receiver/spectrum analyzer is 1 MHz and the video bandwidth is 2 kHz (Duty cycle < 98%).

For IEEE 802.11ac (VHT80):

For radiated emissions frequency above 1 GHz, the resolution bandwidth of test receiver/spectrum analyzer is 1 MHz and the video bandwidth is 3 kHz (Duty cycle < 98%).

2.5 BLOCK DIAGRAM SHOWING THE CONFIGURATION OF SYSTEM TESTED

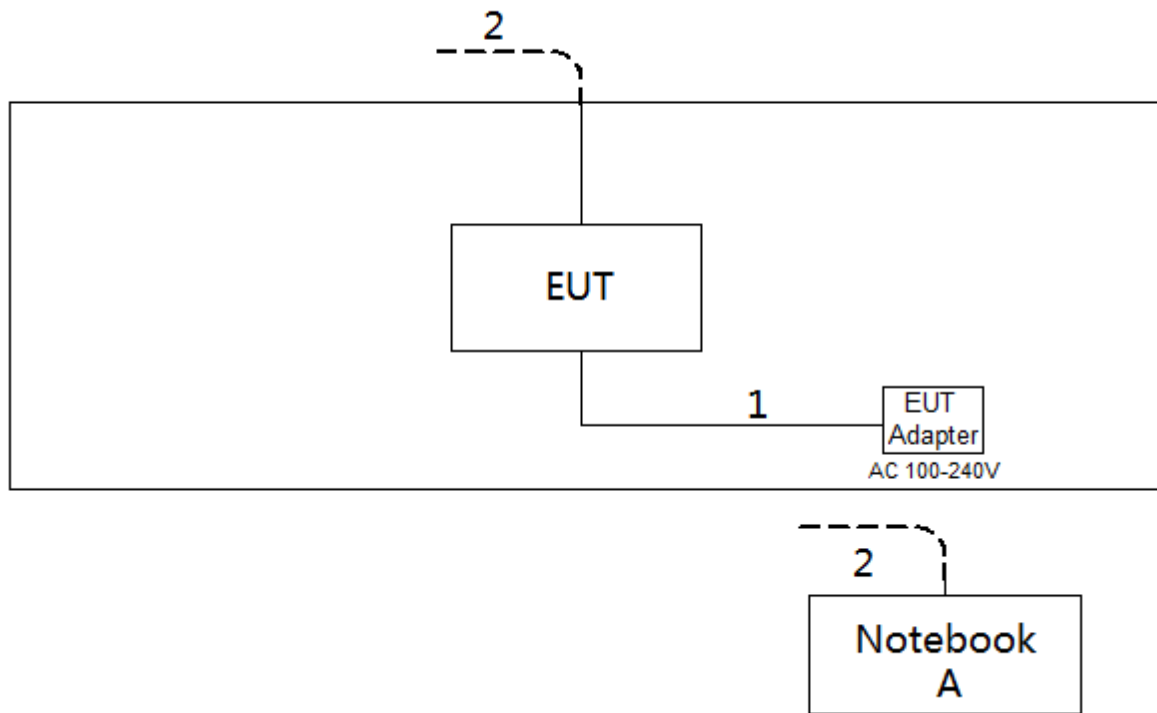

2.6 SUPPORT UNITS

Item	Equipment	Brand	Model No.	Series No.
A	Notebook	Dell	Inspiron 15-7559	N/A

Item	Cable Type	Shielded Type	Ferrite Core	Length
1	DC Cable	NO	NO	1.5m
2	RJ45 Cable	NO	NO	10m

3. AC POWER LINE CONDUCTED EMISSIONS TEST

3.1 LIMIT

Frequency (MHz)	Limit (dB μ V)	
	Quasi-peak	Average
0.15 - 0.5	66 to 56*	56 to 46*
0.5 - 5.0	56	46
5.0 - 30.0	60	50

NOTE:

- (1) The tighter limit applies at the band edges.
- (2) The limit of " * " marked band means the limitation decreases linearly with the logarithm of the frequency in the range.

The following table is the setting of the receiver

Receiver Parameter	Setting
Attenuation	10 dB
Start Frequency	0.15 MHz
Stop Frequency	30 MHz
IF Bandwidth	9 KHz

3.2 TEST PROCEDURE

- a. The EUT was placed 0.8 meters from the horizontal ground plane with EUT being connected to the power mains through a line impedance stabilization network (LISN). All other support equipment powered from additional LISN(s). The LISN provide 50 Ohm/ 50uH of coupling impedance for the measuring instrument.
- b. Interconnecting cables that hang closer than 40 cm to the ground plane shall be folded back and forth in the center forming a bundle 30 to 40 cm long.
- c. I/O cables that are not connected to a peripheral shall be bundled in the center. The end of the cable may be terminated, if required, using the correct terminating impedance. The overall length shall not exceed 1 m.
- d. LISN at least 80 cm from nearest part of EUT chassis.
- e. For the actual test configuration, please refer to the related Item -EUT Test Photos.

3.3 DEVIATION FROM TEST STANDARD

No deviation

3.4 TEST SETUP

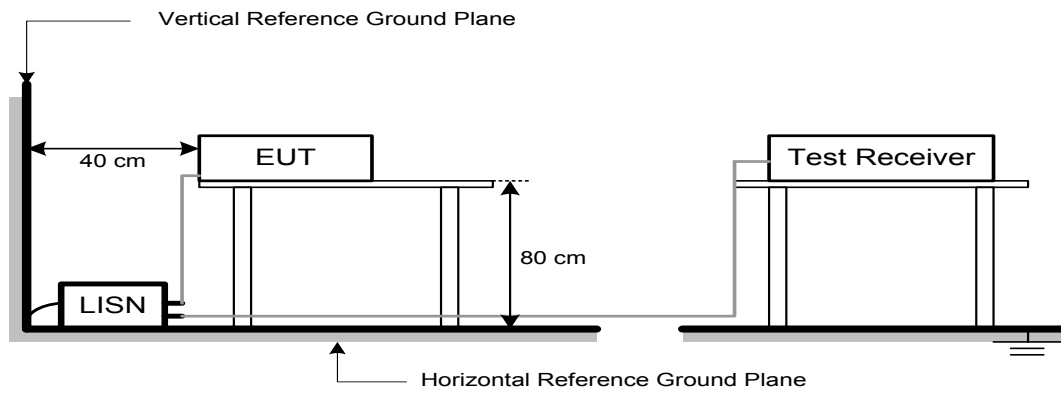

3.5 EUT OPERATION CONDITIONS

The EUT was configured for testing in a typical fashion (as a customer would normally use it). The EUT has been programmed to continuously transmit during test. This operating condition was tested and used to collect the included data.

The EUT was programmed to be in continuously transmitting/TX mode.

3.6 TEST RESULTS

Please refer to the APPENDIX A.

4. RADIATED EMISSIONS TEST

4.1 LIMIT

In case the emission fall within the restricted band specified on 15.205(a), then the 15.209(a) limit in the table below has to be followed.

LIMITS OF RADIATED EMISSIONS MEASUREMENT (9 kHz to 1000 MHz)

Frequency (MHz)	Field Strength (microvolts/meter)	Measurement Distance (meters)
0.009-0.490	2400/F(kHz)	300
0.490-1.705	24000/F(kHz)	30
1.705-30.0	30	30
30-88	100	3
88-216	150	3
216-960	200	3
Above 960	500	3

LIMITS OF UNWANTED EMISSION OUT OF THE RESTRICTED BANDS

Frequency (MHz)	EIRP Limit (dBm/MHz)	Equivalent Field Strength at 3m (dBμV/m)
5150-5250	-27	68.3
5250-5350	-27	68.3
5470-5725	-27	68.3
5725-5850	-27 NOTE (2)	68.3
	10 NOTE (2)	105.3
	15.6 NOTE (2)	110.9
	27 NOTE (2)	122.3

NOTE:

(1) The following formula is used to convert the equipment isotropic radiated power (eirp) to field strength:

$$E = \frac{1000000\sqrt{30P}}{3} \mu\text{V/m, where P is the eirp (Watts)}$$

(2) According to 15.407(b)(4)(i), all emissions shall be limited to a level of -27 dBm/MHz at 75 MHz or more above or below the band edge increasing linearly to 10 dBm/MHz at 25 MHz above or below the band edge, and from 25 MHz above or below the band edge increasing linearly to a level of 15.6 dBm/MHz at 5 MHz above or below the band edge, and from 5 MHz above or below the band edge increasing linearly to a level of 27 dBm/MHz at the band edge.

4.2 TEST PROCEDURE

- a. The measuring distance of 3 m shall be used for measurements. The EUT was placed on the top of a rotating table 0.8 meter above the ground at a 3 meter semi-anechoic chamber. The table was rotated 360 degrees to determine the position of the highest radiation.(below 1GHz)
- b. The measuring distance of 3 m shall be used for measurements. The EUT was placed on the top of a rotating table 1.5 meter above the ground at a 3 meter semi-anechoic chamber. The table was rotated 360 degrees to determine the position of the highest radiation.(above 1GHz)
- c. The height of the equipment or of the substitution antenna shall be 0.8m or 1.5m; the height of the test antenna shall vary between 1 m to 4 m. Both horizontal and vertical polarizations of the antenna are set to make the measurement.
- d. For each suspected emission, the EUT was arranged to its worst case and then the antenna was tuned to heights find the maximum reading (used Bore sight function).
- e. The receiver system was set to peak and average detect function and specified bandwidth with maximum hold mode when the test frequency is above 1 GHz.
- f. The initial step in collecting radiated emission data is a receiver peak detector mode pre-scanning the measurement frequency range. Significant peaks are then marked and then Quasi Peak detector mode re-measured.
- g. All readings are Peak unless otherwise stated QP in column of Note. Peak denotes that the Peak reading compliance with the QP Limits and then QP Mode measurement didn't perform. (below 1 GHz)
- h. All readings are Peak Mode value unless otherwise stated AVG in column of Note. If the Peak Mode Measured value compliance with the Peak Limits and lower than AVG Limits, the EUT shall be deemed to meet both Peak & AVG Limits and then only Peak Mode was measured, but AVG Mode didn't perform. (above 1 GHz)
- i. For the actual test configuration, please refer to the related Item –EUT Test Photos.

4.3 DEVIATION FROM TEST STANDARD

No deviation

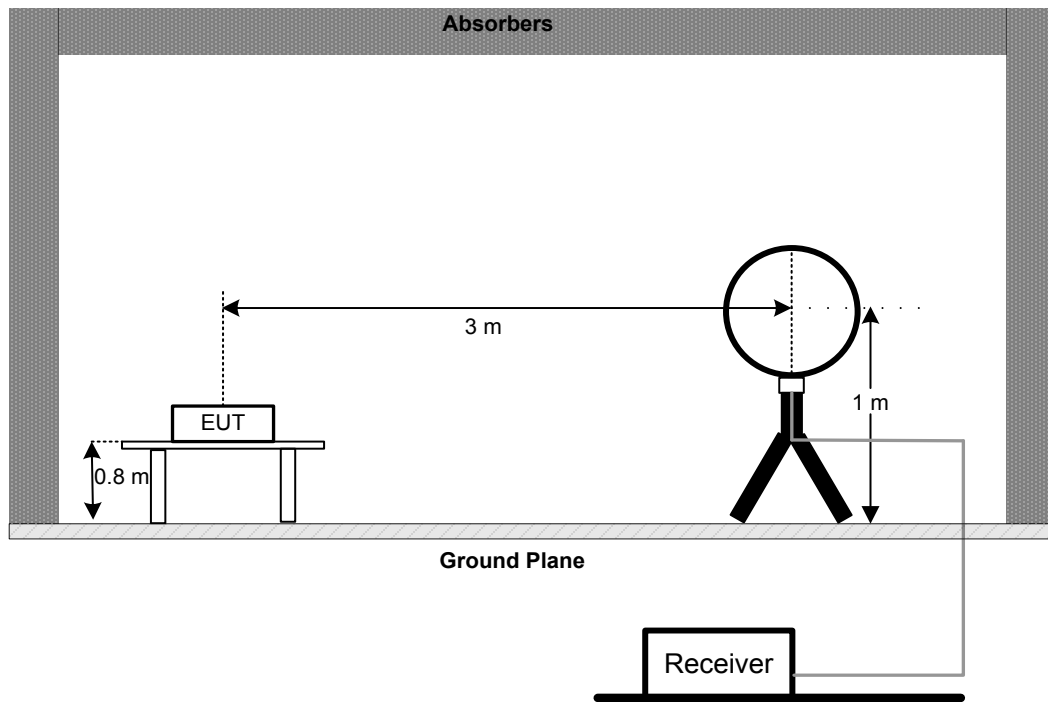
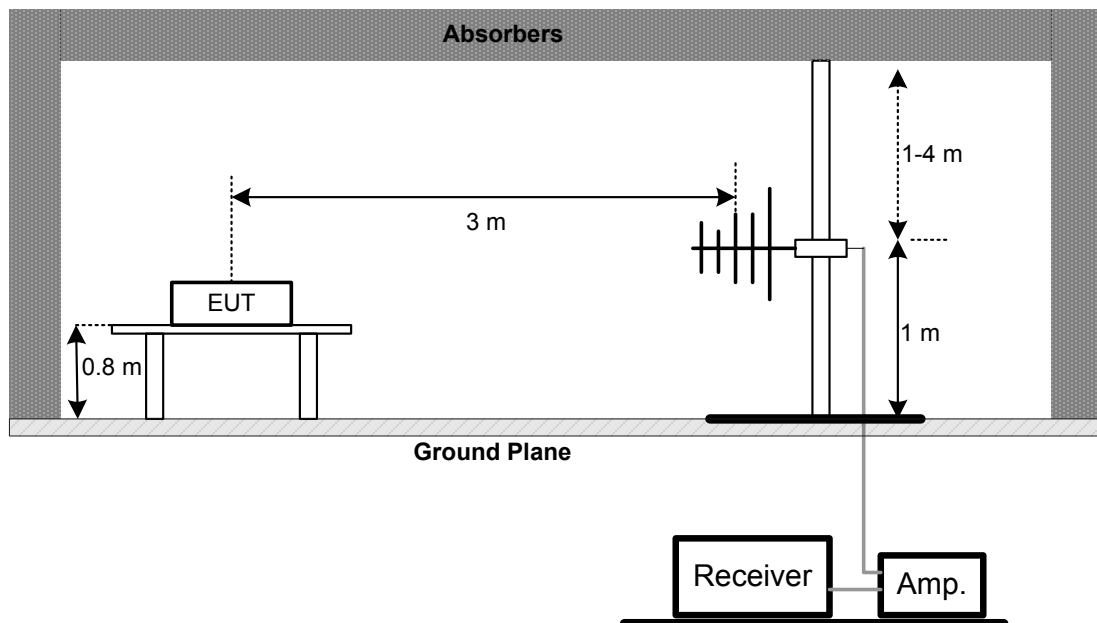
4.4 TEST SETUP**9 kHz to 30 MHz****30 MHz to 1 GHz**

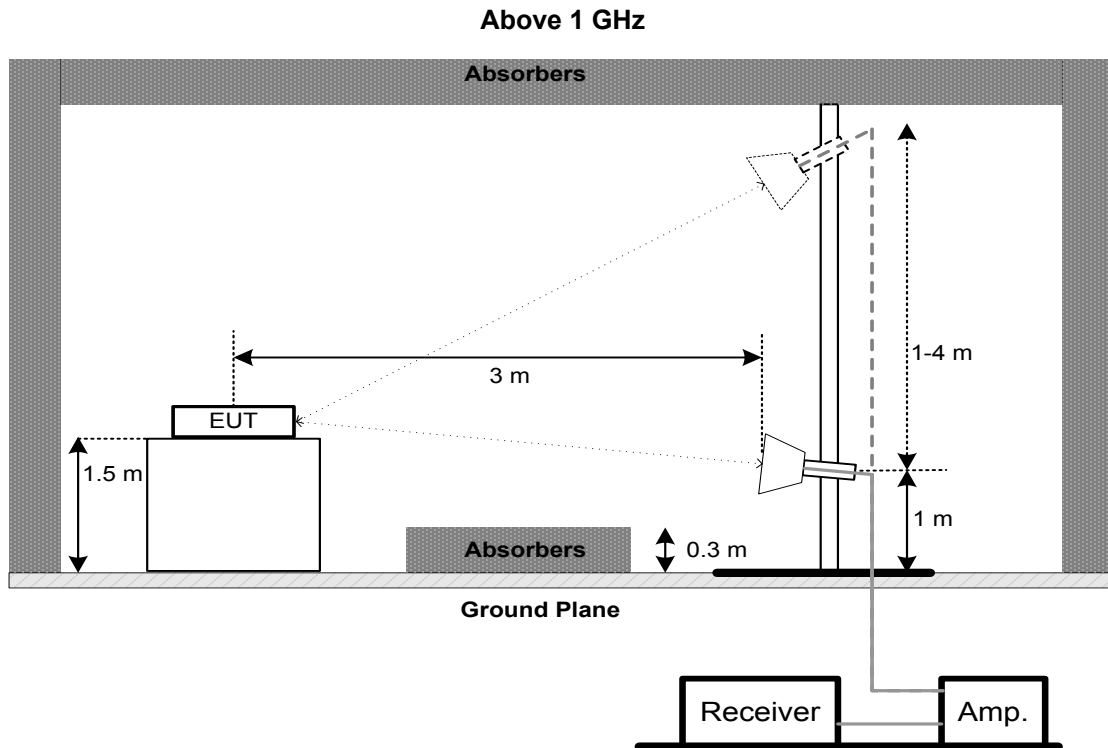

4.5 EUT OPERATION CONDITIONS

The EUT tested system was configured as the statements of 3.5 unless otherwise a special operating condition is specified in the follows during the testing.

4.6 TEST RESULTS - 9 KHZ to 30 MHZ

Please refer to the APPENDIX B

Remark:

- (1) Distance extrapolation factor = $40 \log (\text{specific distance} / \text{test distance})$ (dB).
- (2) Limit line = specific limits (dBuV) + distance extrapolation factor.

4.7 TEST RESULTS - 30 MHZ TO 1000 MHZ

Please refer to the APPENDIX C.

4.8 TEST RESULTS - ABOVE 1000 MHZ

Please refer to the APPENDIX D.

Remark:

- (1) No limit: This is fundamental signal, the judgment is not applicable.
For fundamental signal judgment was referred to Peak output test.

5. BANDWIDTH TEST

5.1 LIMIT

FCC Part15, Subpart E (15.407)			
Section	Test Item	Limit	Frequency Range (MHz)
15.407(a) 15.407(e)	26 dB Bandwidth	-	5150-5250
	26 dB Bandwidth	-	5250-5350
	26 dB Bandwidth	-	5470-5725
	6 dB Bandwidth	Minimum 500 kHz	5725-5850

5.2 TEST PROCEDURE

- The EUT was directly connected to the spectrum analyzer and antenna output port as show in the block diagram below
- Spectrum Setting:
For UNII-1, UNII-2A, UNII-2C:

Spectrum Parameter	Setting
Attenuation	Auto
Span Frequency	> 26 dB Bandwidth
RBW	300 kHz (Bandwidth 20 MHz) 1 MHz (Bandwidth 40 MHz and 80 MHz)
VBW	1 MHz (Bandwidth 20 MHz) 3 MHz (Bandwidth 40 MHz and 80 MHz)
Detector	Peak
Trace	Max Hold
Sweep Time	Auto

For UNII-3:

Spectrum Parameter	Setting
Attenuation	Auto
Span Frequency	6 dB Bandwidth
RBW	100 kHz
VBW	300 kHz
Detector	Peak
Trace	Max Hold
Sweep Time	Auto

- Measured the spectrum width with power higher than 26 dB / 6dB below carrier

5.3 TEST PROCEDURE

No deviation.

5.4 TEST SETUP



5.5 EUT OPERATION CONDITIONS

The EUT was programmed to be in continuously transmitting mode.

5.6 TEST RESULTS

Please refer to the APPENDIX E.

6. CONDUCTED OUTPUT POWER TEST

6.1 LIMIT

FCC Part15, Subpart E (15.407)			
Section	Test Item	Limit	Frequency Range (MHz)
15.407(a)	Conducted Output Power	AP device: 1 Watt (30 dBm) Client device: 250 mW (24 dBm)	5150-5250
		250 mW (24 dBm)	5250-5350
		250 mW (24 dBm)	5470-5725
		1 Watt (30dBm)	5725-5850

Note:

- a. For an indoor access point operating in the band 5.15-5.25 GHz, the maximum conducted output power over the frequency band of operation shall not exceed 1 W provided the maximum antenna gain does not exceed 6 dBi. In addition, the maximum power spectral density shall not exceed 17 dBm in any 1 megahertz band. If transmitting antennas of directional gain greater than 6 dBi are used, both the maximum conducted output power and the maximum power spectral density shall be reduced by the amount in dB that the directional gain of the antenna exceeds 6 dBi.
- b. For the 5.25-5.35 GHz and 5.47-5.725 GHz bands, the maximum conducted output power over the frequency bands of operation shall not exceed the lesser of 250 mW or 11 dBm + 10log B, where B is the 26dB Bandwidth in megahertz.

6.2 TEST PROCEDURE

- a. The EUT was directly connected to the power meter and antenna output port as show in the block diagram below.
- b. Test test was performed in accordance with method of FCC KDB 789033 D02 General UNII Test Procedures New Rules v02r01.

6.3 DEVIATION FROM STANDARD

No deviation.

6.4 TEST SETUP



6.5 EUT OPERATION CONDITIONS

The EUT was programmed to be in continuously transmitting mode.

6.6 TEST RESULTS

Please refer to the APPENDIX F.

7. POWER SPECTRAL DENSITY TEST

7.1 LIMIT

FCC Part15, Subpart E (15.407)			
Section	Test Item	Limit	Frequency Range (MHz)
15.407(a)	Power Spectral Density	AP device: 17 dBm/MHz Client device: 11 dBm/MHz	5150-5250
		11 dBm/MHz	5250-5350
		11 dBm/MHz	5470-5725
		30 dBm/500 kHz	5725-5850

7.2 TEST PROCEDURE

- a. The EUT was directly connected to the spectrum analyzer and antenna output port as show in the block diagram below.
- b. Spectrum Setting:

Spectrum Parameter	Setting
Attenuation	Auto
Span Frequency	Encompass the entire emissions bandwidth (EBW) of the signal
RBW	= 1 MHz.
VBW	≥ 3 MHz.
Detector	RMS
Trace average	100 trace
Sweep Time	Auto

Note:

- The value measured with RBW=1 MHz is to be added with $10\log(500\text{ kHz}/1\text{ MHz})$ which is -3 dB. For example, if the measured value is +10dBm using RBW=1 MHz (that is +10 dBm/MHz), then the converted value will be +7dBm/500kHz.

7.3 DEVIATION FROM STANDARD

No deviation.

7.4 TEST SETUP

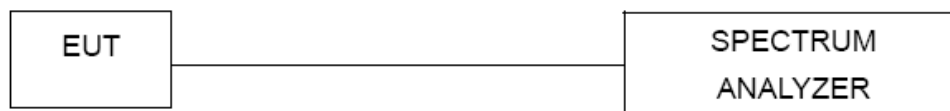

7.5 EUT OPERATION CONDITIONS

The EUT was programmed to be in continuously transmitting mode.

7.6 TEST RESULTS

Please refer to the APPENDIX G.

8. FREQUENCY STABILITY MEASUREMENT

8.1 LIMIT

FCC Part15, Subpart E (15.407)			
Section	Test Item	Limit	Frequency Range (MHz)
15.407(g)	Frequency Stability	An emission is maintained within the band of operation under all conditions of normal operation as specified in the users manual.	5150-5250
			5250-5350
			5470-5725
			5725-5850

8.2 TEST PROCEDURE

- The EUT was directly connected to the spectrum analyzer and antenna output port as show in the block diagram below.
- Spectrum Setting:

Spectrum Parameter	Setting
Attenuation	Auto
Span Frequency	Entire absence of modulation emissions bandwidth
RBW	10 kHz
VBW	10 kHz
Sweep Time	Auto

- The test extreme voltage is to change the primary supply voltage from 85 to 115 percent of the nominal value.
- User manual temperature is 0°C~40°C.

8.3 DEVIATION FROM STANDARD

No deviation.

8.4 TEST SETUP

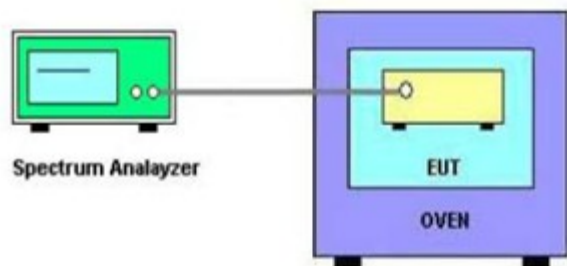

8.5 EUT OPERATION CONDITIONS

The EUT was programmed to be in continuously transmitting mode.

8.6 TEST RESULTS

Please refer to the APPENDIX H.

9. MEASUREMENT INSTRUMENTS LIST

AC Power Line Conducted Emissions					
Item	Kind of Equipment	Manufacturer	Type No.	Serial No.	Calibrated until
1	EMI Test Receiver	R&S	ESCI	100382	Mar. 10, 2020
2	LISN	EMCO	3816/2	52765	Mar. 10, 2020
3	TWO-LINE V-NETWORK	R&S	ENV216	101447	May. 19, 2020
4	50Ω Terminator	SHX	TF5-3	15041305	Mar. 10, 2020
5	Measurement Software	Farad	EZ-EMC Ver.NB-03A1-01	N/A	N/A
6	Cable	N/A	RG223	12m	Mar. 12, 2020

Radiated Emissions - 9 kHz to 30 MHz					
Item	Kind of Equipment	Manufacturer	Type No.	Serial No.	Calibrated until
1	Loop Antenna	EM	EM-6876-1	230	Jan. 15, 2020
2	Cable	N/A	RG 213/U	C-102	May 31, 2020
3	EMI Test Receiver	R&S	ESCI	100895	Mar. 10, 2020
4	Measurement Software	Farad	EZ-EMC Ver.NB-03A1-01	N/A	N/A

Radiated Emissions - 30 MHz to 1 GHz					
Item	Kind of Equipment	Manufacturer	Type No.	Serial No.	Calibrated until
1	Antenna	Schwarzbeck	VULB9160	9160-3232	Mar. 09, 2020
2*	Amplifier	HP	8447D	2944A09673	Aug. 11, 2021
3	Receiver	Agilent	N9038A	MY52130039	Aug. 03, 2020
4	Cable	emci	LMR-400(30MHz-1 GHz)(8m+5m)	N/A	May 24, 2020
5	Controller	CT	SC100	N/A	N/A
6	Controller	MF	MF-7802	MF780208416	N/A
7	Measurement Software	Farad	EZ-EMC Ver.NB-03A1-01	N/A	N/A

Radiated Emissions - Above 1 GHz					
Item	Kind of Equipment	Manufacturer	Type No.	Serial No.	Calibrated until
1	Double Ridged Guide Antenna	ETS	3115	75789	Mar. 09, 2020
2	Broad-Band Horn Antenna	Schwarzbeck	BBHA 9170	9170319	Jun. 23, 2020
3	Amplifier	Agilent	8449B	3008A02333	Mar. 10, 2020
4	Microwave Preamplifier With Adaptor	EMC INSTRUMENT	EMC2654045	980039 & HA01	Mar. 10, 2020
5	Receiver	Agilent	N9038A	MY52130039	Aug. 03, 2020
6	Controller	CT	SC100	N/A	N/A
7	Controller	MF	MF-7802	MF780208416	N/A
8	Cable	mitron	B10-01-01-12M	18072744	Jun. 29, 2020
9	Measurement Software	Farad	EZ-EMC Ver.NB-03A1-01	N/A	N/A

Bandwidth & Power Spectral Density					
Item	Kind of Equipment	Manufacturer	Type No.	Serial No.	Calibrated until
1	Spectrum Analyzer	R&S	FSP40	100185	Aug. 03, 2020

Conducted Output Power					
Item	Kind of Equipment	Manufacturer	Type No.	Serial No.	Calibrated until
1	Peak Power Analyzer	Keysight	8990B	MY51000506	Aug. 03, 2020
2	Wideband power sensor	Keysight	N1923A	MY58310004	Aug. 03, 2020

Frequency Stability					
Item	Kind of Equipment	Manufacturer	Type No.	Serial No.	Calibrated until
1	Spectrum Analyzer	R&S	FSP40	100185	Aug. 03, 2020
2	Precision Oven Tester	Bell	BTH-50C	20170306001	Mar. 10, 2020

Remark: "N/A" denotes no model name, serial no. or calibration specified.

"*" calibration period of equipment list is three year.

Except * item, all calibration period of equipment list is one year.

10. EUT TEST PHOTOS**AC Power Line Conducted Emissions Test Photos**

Radiated Emissions Test Photos**9 kHz to 30 MHz**

Radiated Emissions Test Photos

30 MHz to 1 GHz

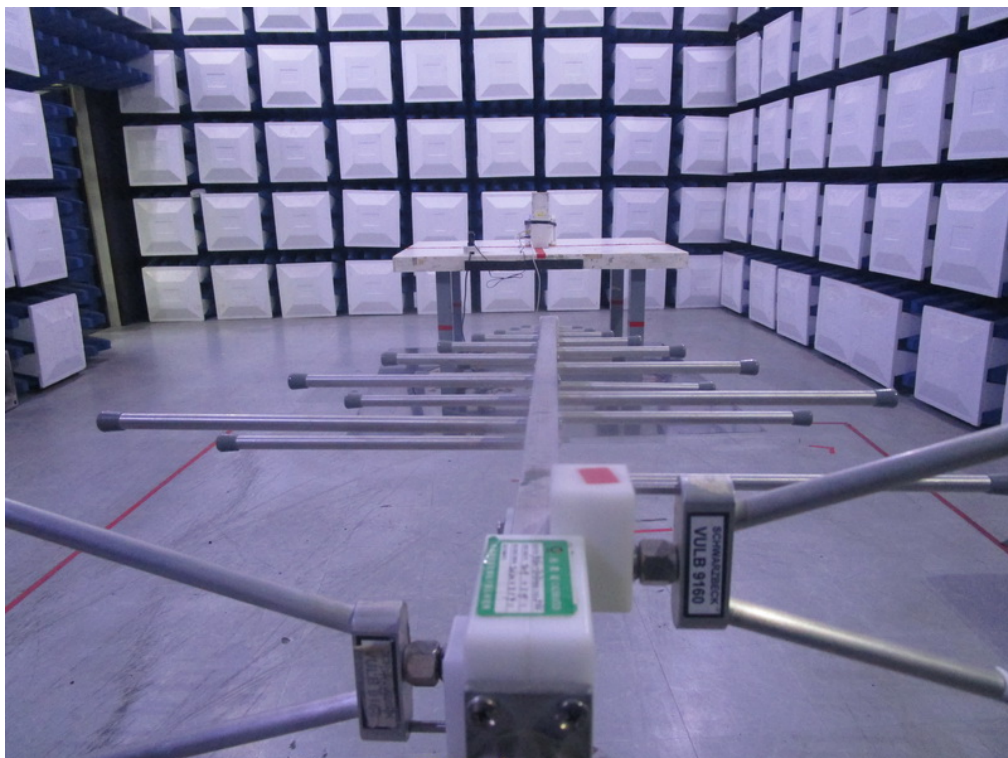

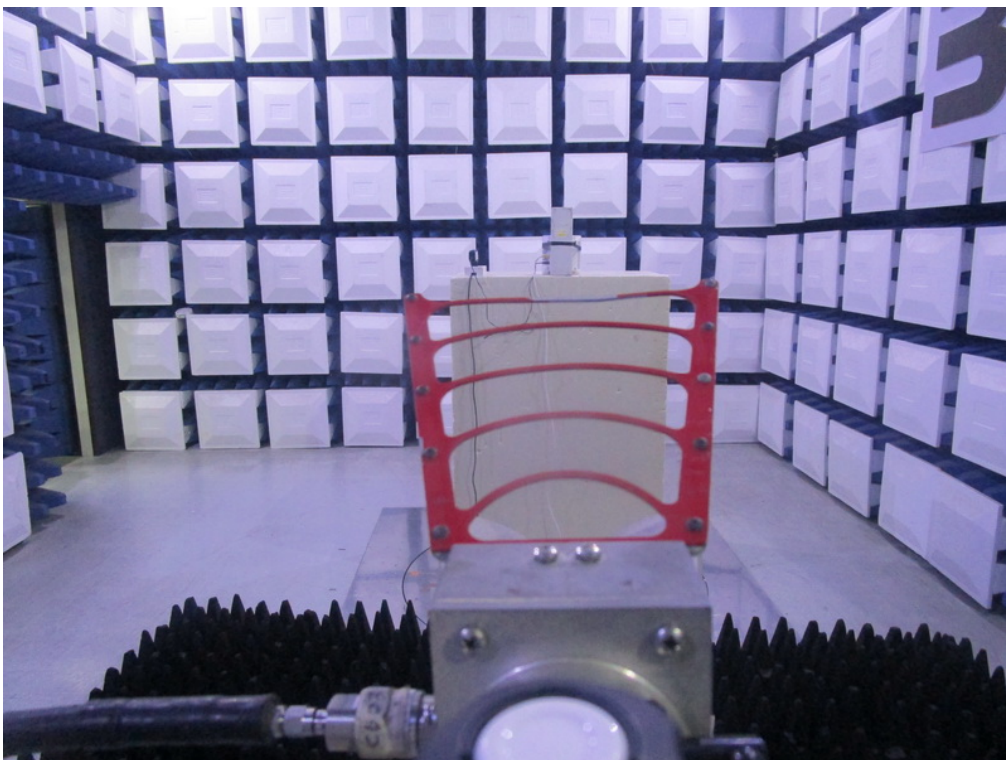
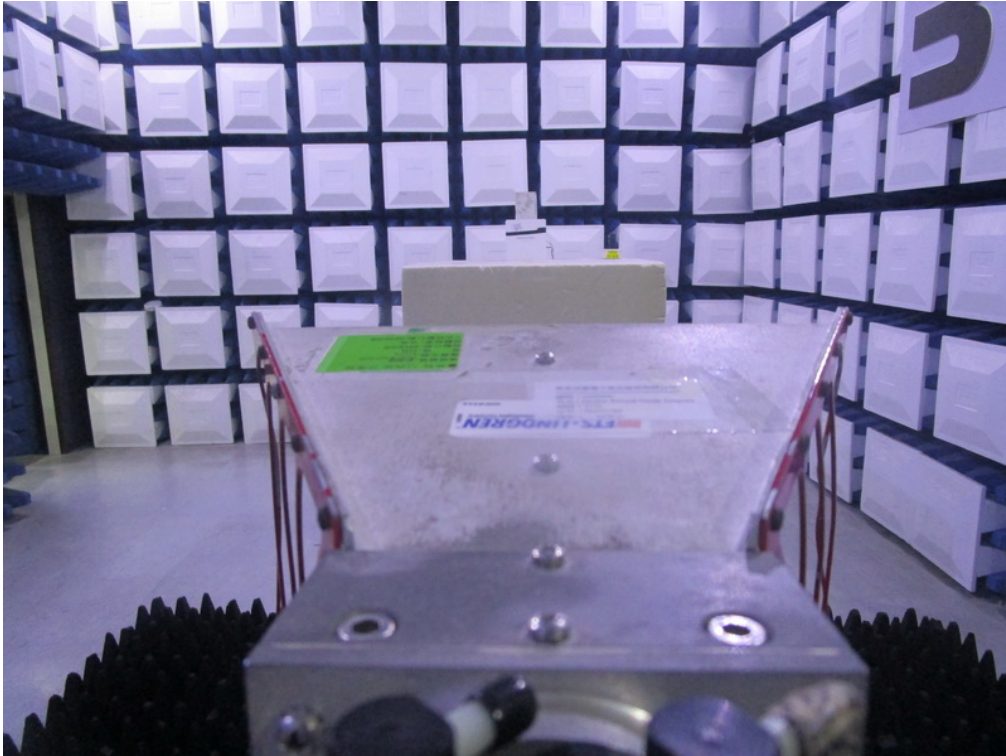
Radiated Emissions Test Photos**Above 1 GHz**

APPENDIX A - AC POWER LINE CONDUCTED EMISSIONS

Test Mode: TX AC20 Mode Channel 165

Line

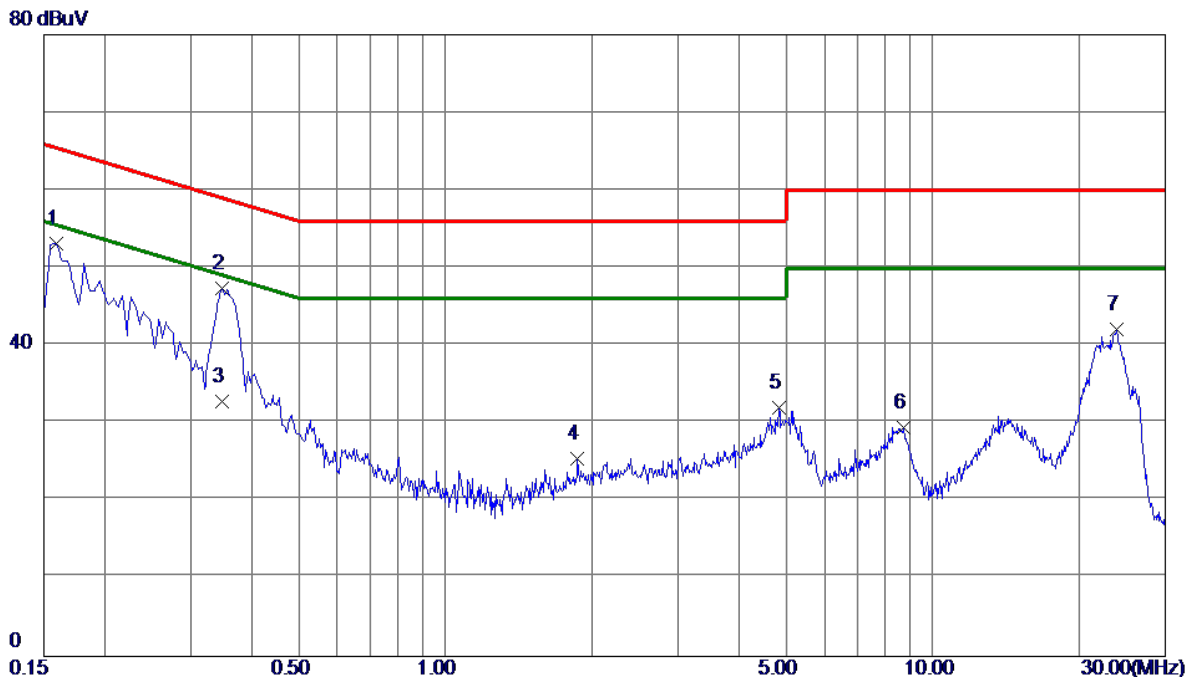

No.	Freq. MHz	Reading Level dBuV	Correct Factor dB	Measure ment dBuV	Limit dBuV	Margin dB	Detector	Comment
1	0.1590	43.34	9.82	53.16	65.52	-12.36	Peak	
2 *	0.3480	37.58	9.85	47.43	59.01	-11.58	Peak	
3	0.3480	22.90	9.85	32.75	49.01	-16.26	AVG	
4	1.8690	15.45	9.99	25.44	56.00	-30.56	Peak	
5	4.8255	21.78	10.18	31.96	56.00	-24.04	Peak	
6	8.6955	19.09	10.42	29.51	60.00	-30.49	Peak	
7	23.8785	30.93	11.14	42.07	60.00	-17.93	Peak	

REMARKS:

- (1) Measurement Value = Reading Level + Correct Factor.
- (2) Margin Level = Measurement Value - Limit Value.
- (3) The test result has included the cable loss.

Test Mode: TX AC20 Mode Channel 165

Neutral

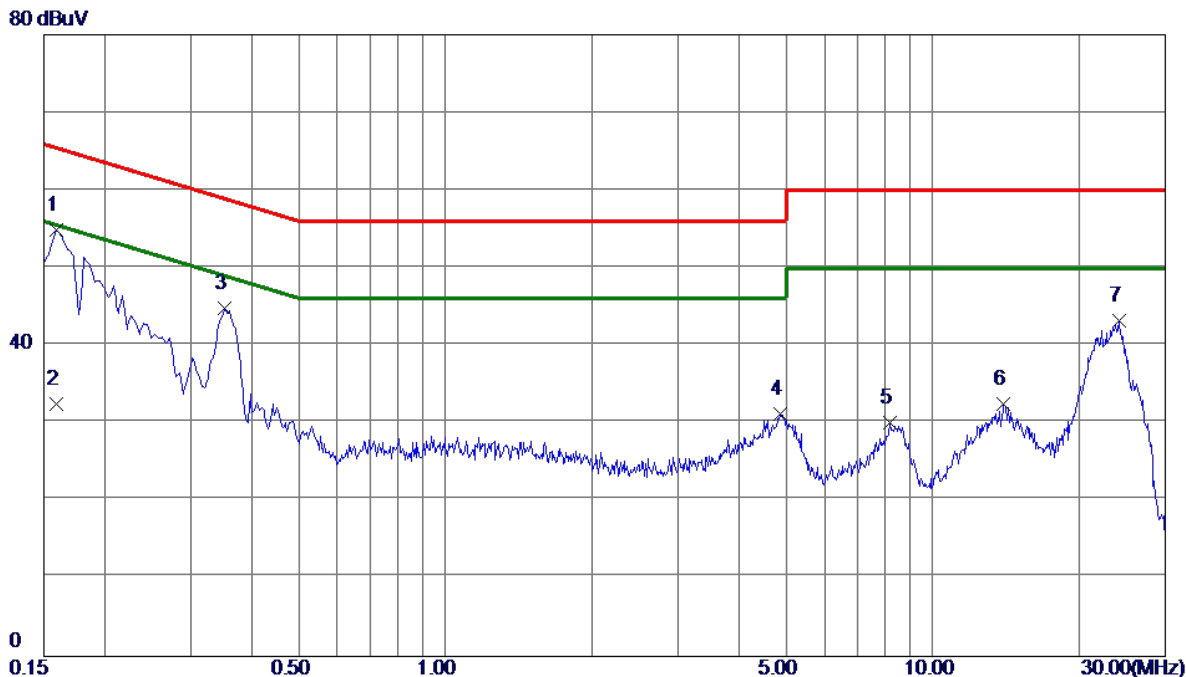

No.	Freq. MHz	Reading Level dBuV	Correct Factor dB	Measure ment dBuV	Limit dBuV	Margin dB	Detector	Comment
1 *	0.1590	44.91	9.91	54.82	65.52	-10.70	Peak	
2	0.1590	22.60	9.91	32.51	55.52	-23.01	AVG	
3	0.3525	34.74	9.99	44.73	58.90	-14.17	Peak	
4	4.8570	20.88	10.39	31.27	56.00	-24.73	Peak	
5	8.1915	19.44	10.65	30.09	60.00	-29.91	Peak	
6	13.9965	21.47	11.01	32.48	60.00	-27.52	Peak	
7	24.0630	31.78	11.48	43.26	60.00	-16.74	Peak	

REMARKS:

- (1) Measurement Value = Reading Level + Correct Factor.
- (2) Margin Level = Measurement Value - Limit Value.
- (3) The test result has included the cable loss.

APPENDIX B - RADIATED EMISSION - 9 KHZ TO 30 MHZ

Test Mode: TX AC20 Mode Channel 165

Ant 0°

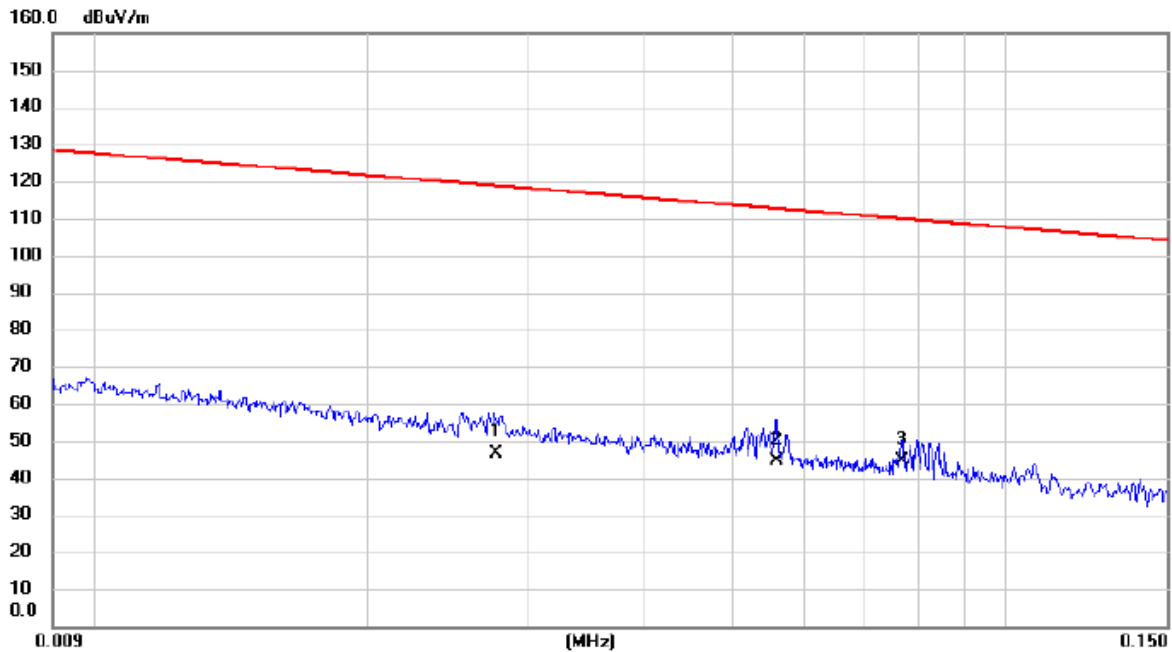

No.	Mk.	Freq.	Reading Level	Correct Factor	Measurement	Limit	Margin	Detector	Comment
		MHz	dBuV	dB	dBuV/m	dBuV/m	dB		
1		0.0276	32.60	13.85	46.45	118.79	-72.34	AVG	
2		0.0560	30.81	13.83	44.64	112.64	-68.00	AVG	
3	*	0.0768	31.20	13.53	44.73	109.90	-65.17	AVG	

REMARKS:

- (1) Measurement Value = Reading Level + Correct Factor.
- (2) Margin Level = Measurement Value - Limit Value.

Test Mode: TX AC20 Mode Channel 165

Ant 0°

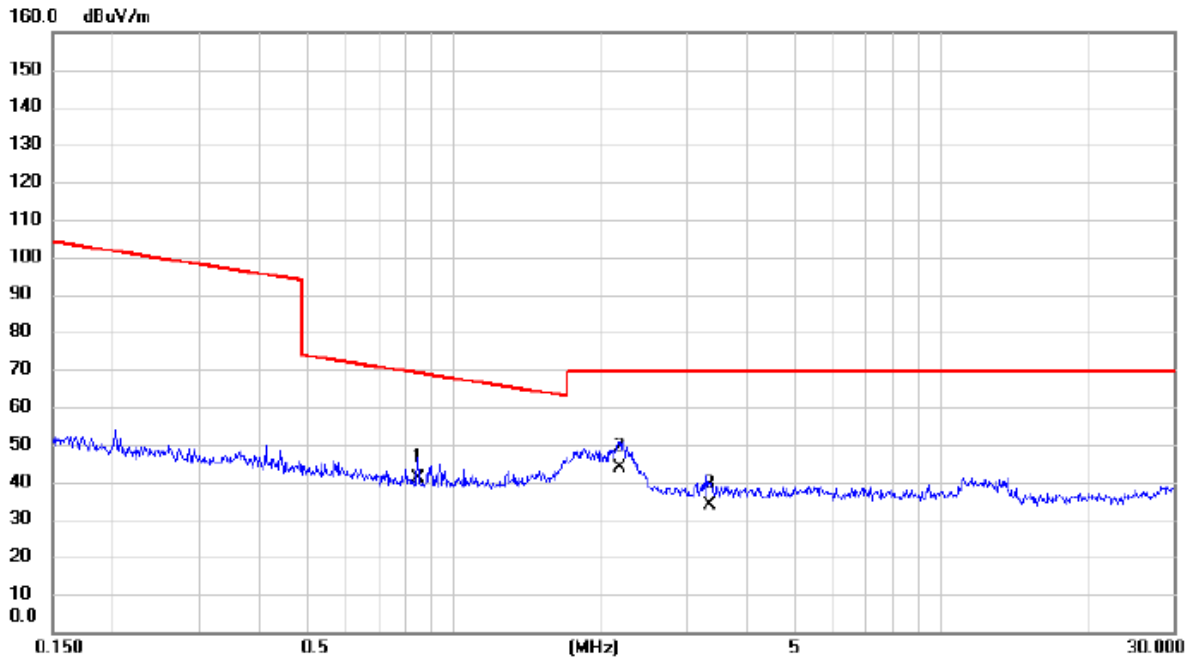

No.	Mk.	Freq. MHz	Reading Level dBuV	Correct Factor dB	Measure- ment dBuV/m	Limit dBuV/m	Margin dB	Detector	Comment
1		0.8438	28.30	12.55	40.85	69.08	-28.23	QP	
2	*	2.1898	32.10	11.71	43.81	69.54	-25.73	QP	
3		3.3458	22.80	11.14	33.94	69.54	-35.60	QP	

REMARKS:

- (1) Measurement Value = Reading Level + Correct Factor.
- (2) Margin Level = Measurement Value - Limit Value.

Test Mode: TX AC20 Mode Channel 165

Ant 90°

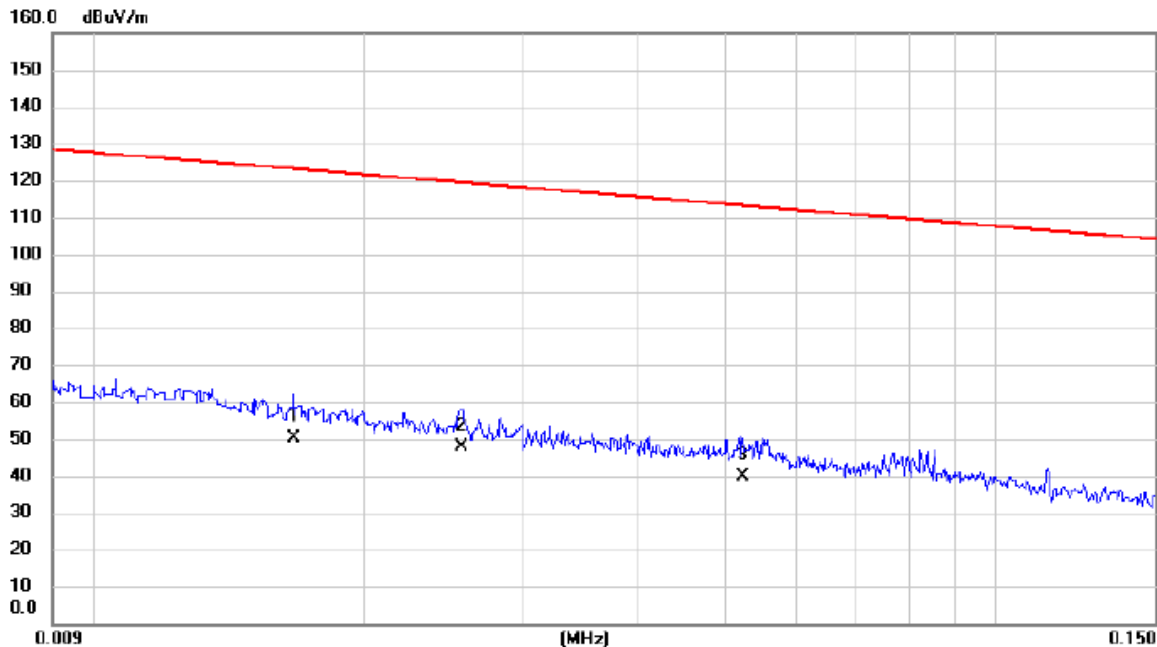

No.	Mk.	Freq.	Reading Level	Correct Factor	Measurement	Limit	Margin	Detector	Comment
		MHz	dBuV	dB	dBuV/m	dBuV/m	dB		
1		0.0167	35.20	14.81	50.01	123.15	-73.14	AVG	
2	*	0.0256	33.80	13.84	47.64	119.44	-71.80	AVG	
3		0.0524	26.10	13.89	39.99	113.22	-73.23	AVG	

REMARKS:

- (1) Measurement Value = Reading Level + Correct Factor.
- (2) Margin Level = Measurement Value - Limit Value.

Test Mode: TX AC20 Mode Channel 165

Ant 90°

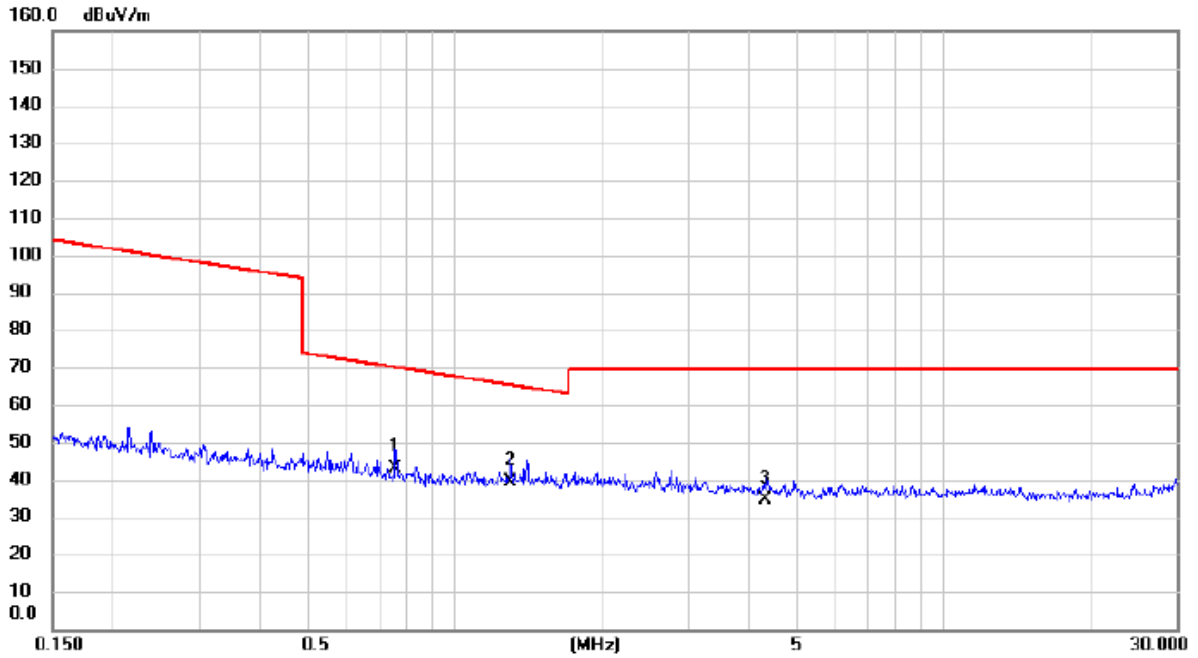

No.	Mk.	Freq.	Reading Level	Correct Factor	Measurement	Limit	Margin	Detector	Comment
		MHz	dBuV	dB	dBuV/m	dBuV/m	dB		
1		0.7550	30.30	12.58	42.88	70.05	-27.17	QP	
2	*	1.2960	27.20	12.29	39.49	65.35	-25.86	QP	
3		4.3146	23.80	10.92	34.72	69.54	-34.82	QP	

REMARKS:

- (1) Measurement Value = Reading Level + Correct Factor.
- (2) Margin Level = Measurement Value - Limit Value.

APPENDIX C - RADIATED EMISSION - 30 MHZ TO 1 GHZ

Test Mode: TX AC20 Mode Channel 165

Vertical

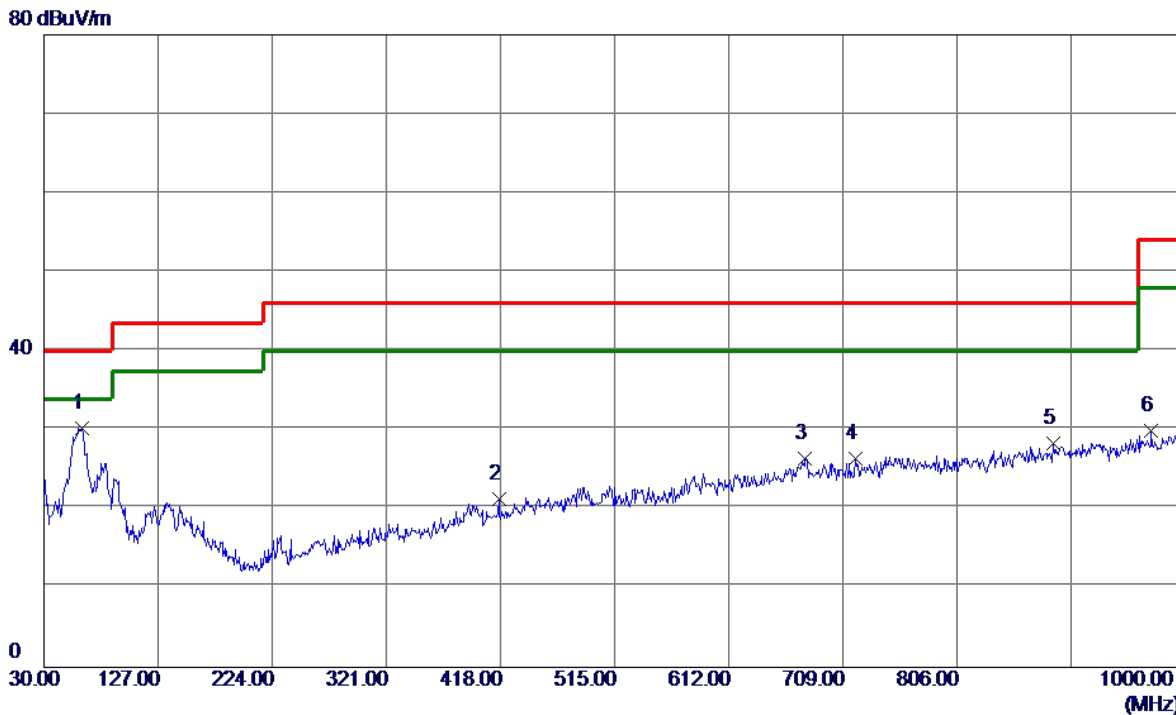

No.	Freq. MHz	Reading Level dBuV/m	Correct Factor dB	Measure ment dBuV/m	Limit dBuV/m	Margin dB	Detector	Comment
1 *	62.4950	45.28	-15.00	30.28	40.00	-9.72	Peak	
2	416.5450	30.27	-9.01	21.26	46.00	-24.74	Peak	
3	676.9900	30.68	-4.32	26.36	46.00	-19.64	Peak	
4	719.6700	30.25	-3.87	26.38	46.00	-19.62	Peak	
5	887.9650	30.29	-2.02	28.27	46.00	-17.73	Peak	
6	971.3850	30.37	-0.41	29.96	54.00	-24.04	Peak	

REMARKS:

- (1) Measurement Value = Reading Level + Correct Factor.
- (2) Margin Level = Measurement Value - Limit Value.

Test Mode: TX AC20 Mode Channel 165

Horizontal

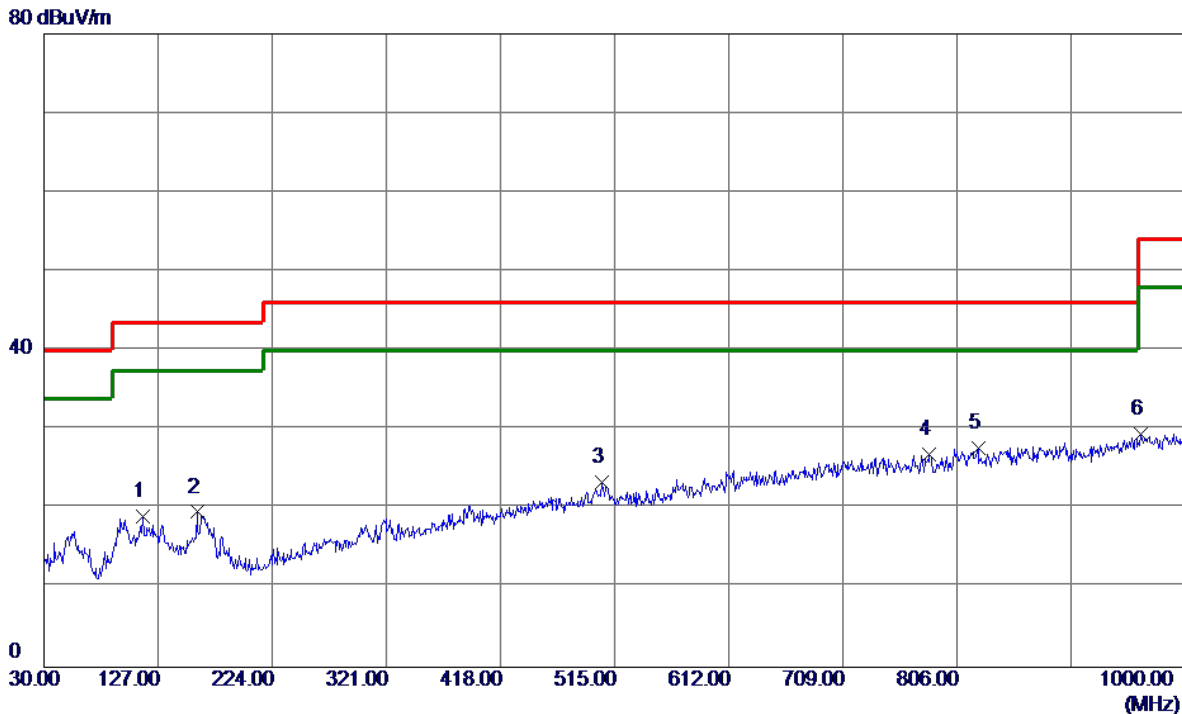

No.	Freq. MHz	Reading Level dBuV/m	Correct Factor dB	Measure ment dBuV/m	Limit dBuV/m	Margin dB	Detector	Comment
1	114.3900	32.86	-13.87	18.99	43.50	-24.51	Peak	
2	160.4650	30.67	-11.07	19.60	43.50	-23.90	Peak	
3	503.8450	31.02	-7.65	23.37	46.00	-22.63	Peak	
4	782.7199	30.06	-3.23	26.83	46.00	-19.17	Peak	
5 *	823.9450	30.33	-2.69	27.64	46.00	-18.36	Peak	
6	962.1700	30.01	-0.57	29.44	54.00	-24.56	Peak	

REMARKS:

- (1) Measurement Value = Reading Level + Correct Factor.
- (2) Margin Level = Measurement Value - Limit Value.

APPENDIX D - RADIATED EMISSION - ABOVE 1000 MHZ

Orthogonal Axis	X
Test Mode	UNII-1_TX A Mode 5180 MHz

Vertical

130 dBuV/m

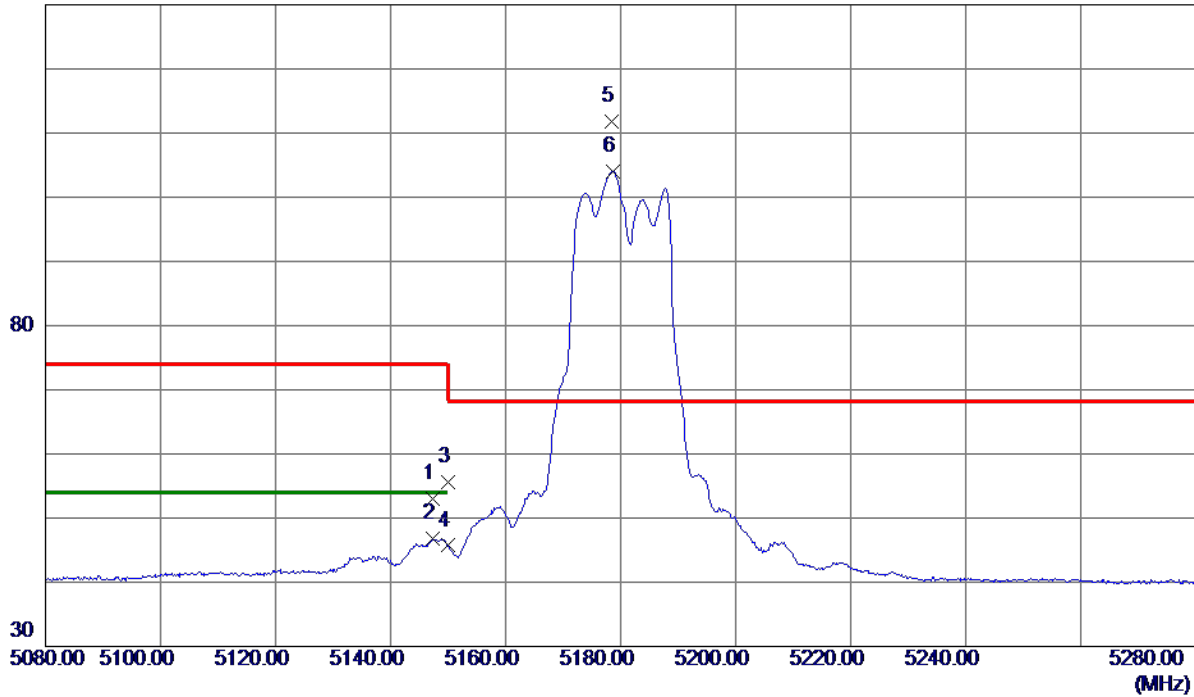

No.	Freq. MHz	Reading Level dBuV/m	Correct Factor dB	Measure ment dBuV/m	Limit dBuV/m	Margin dB	Detector	Comment
1	5147.3000	39.50	13.44	52.94	74.00	-21.06	Peak	
2	5147.3000	33.35	13.44	46.79	54.00	-7.21	AVG	
3	5150.0000	42.16	13.45	55.61	74.00	-18.39	Peak	
4	5150.0000	32.25	13.45	45.70	54.00	-8.30	AVG	
5 *	5178.4000	98.32	13.52	111.84	68.30	43.54	Peak	No Limit
6	5178.6000	90.51	13.52	104.03	999.00	-894.97	AVG	No Limit

REMARKS:

- (1) Measurement Value = Reading Level + Correct Factor.
- (2) Margin Level = Measurement Value - Limit Value.

Orthogonal Axis	X
Test Mode	UNII-1_TX A Mode 5180 MHz

Vertical

80 dBuV/m

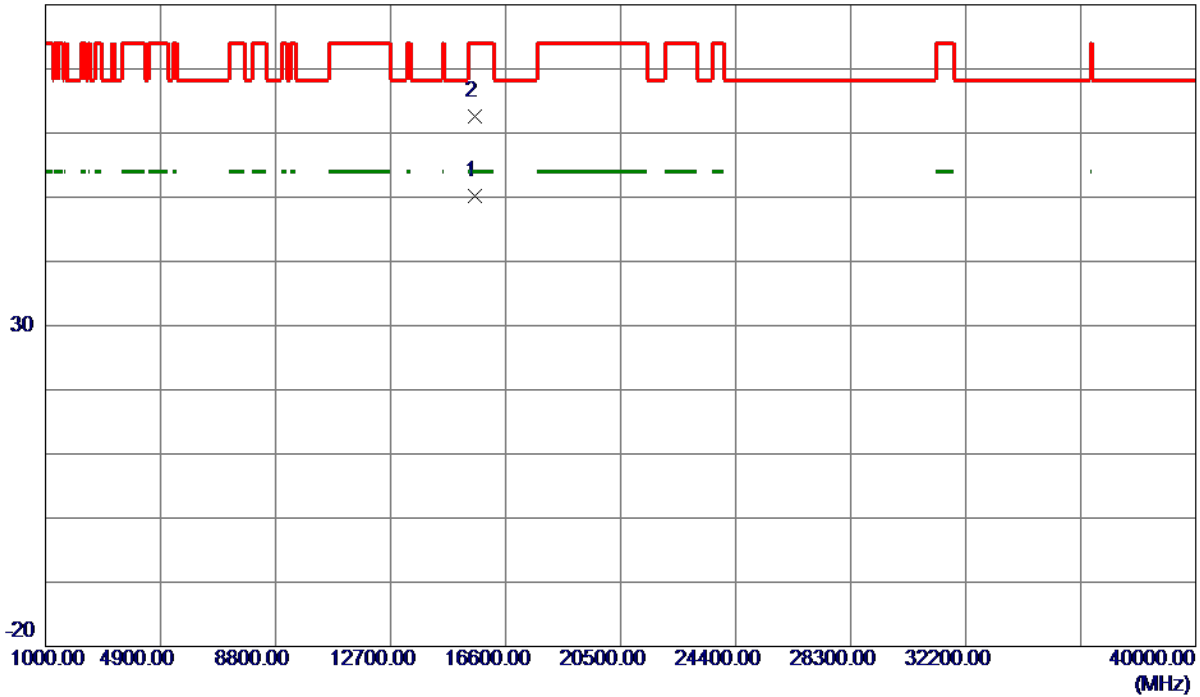

No.	Freq. MHz	Reading Level dBuV/m	Correct Factor dB	Measure ment dBuV/m	Limit dBuV/m	Margin dB	Detector	Comment
1 *	15539.0850	35.26	14.98	50.24	54.00	-3.76	AVG	
2	15540.1750	47.60	14.98	62.58	74.00	-11.42	Peak	

REMARKS:

- (1) Measurement Value = Reading Level + Correct Factor.
- (2) Margin Level = Measurement Value - Limit Value.

Orthogonal Axis	X
Test Mode	UNII-1_TX A Mode 5180 MHz

Horizontal

130 dBuV/m

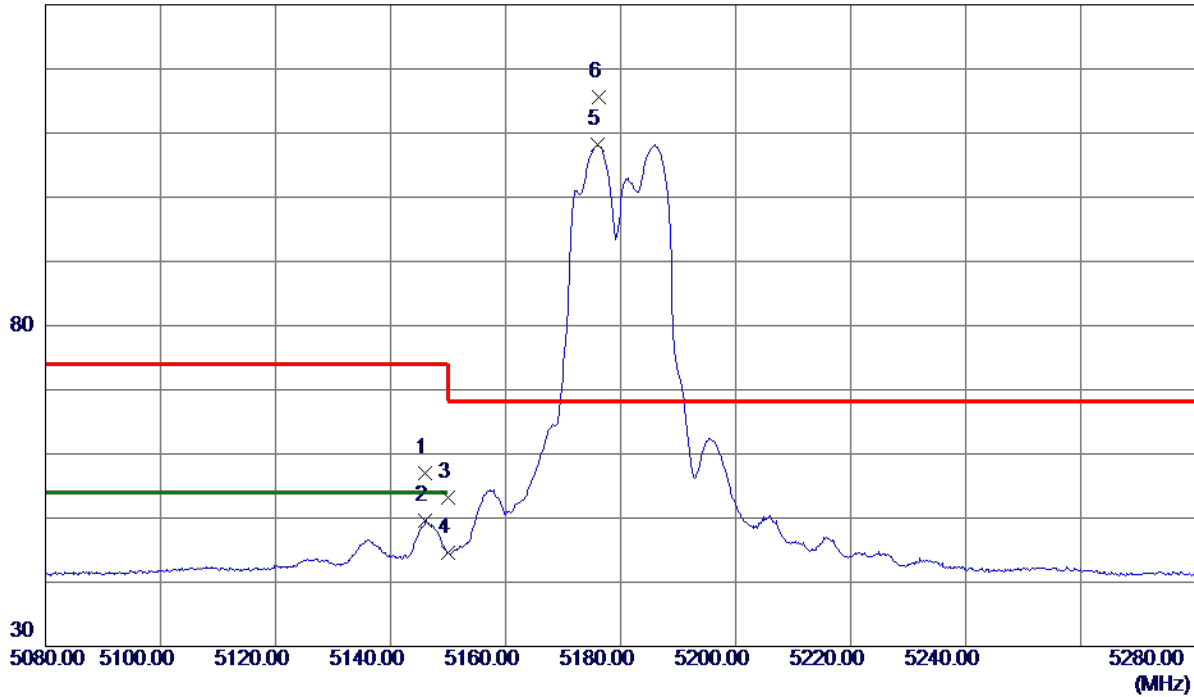

No.	Freq. MHz	Reading Level dBuV/m	Correct Factor dB	Measure ment dBuV/m	Limit dBuV/m	Margin dB	Detector	Comment
1	5146.1000	43.60	13.44	57.04	74.00	-16.96	Peak	
2	5146.1000	36.21	13.44	49.65	54.00	-4.35	AVG	
3	5150.0000	39.82	13.45	53.27	74.00	-20.73	Peak	
4	5150.0000	31.14	13.45	44.59	54.00	-9.41	AVG	
5	5175.9000	94.62	13.51	108.13	999.00	-890.87	AVG	No Limit
6 *	5176.2000	102.09	13.51	115.60	68.30	47.30	Peak	No Limit

REMARKS:

- (1) Measurement Value = Reading Level + Correct Factor.
- (2) Margin Level = Measurement Value - Limit Value.

Orthogonal Axis	X
Test Mode	UNII-1_TX A Mode 5180 MHz

Horizontal

80 dBuV/m

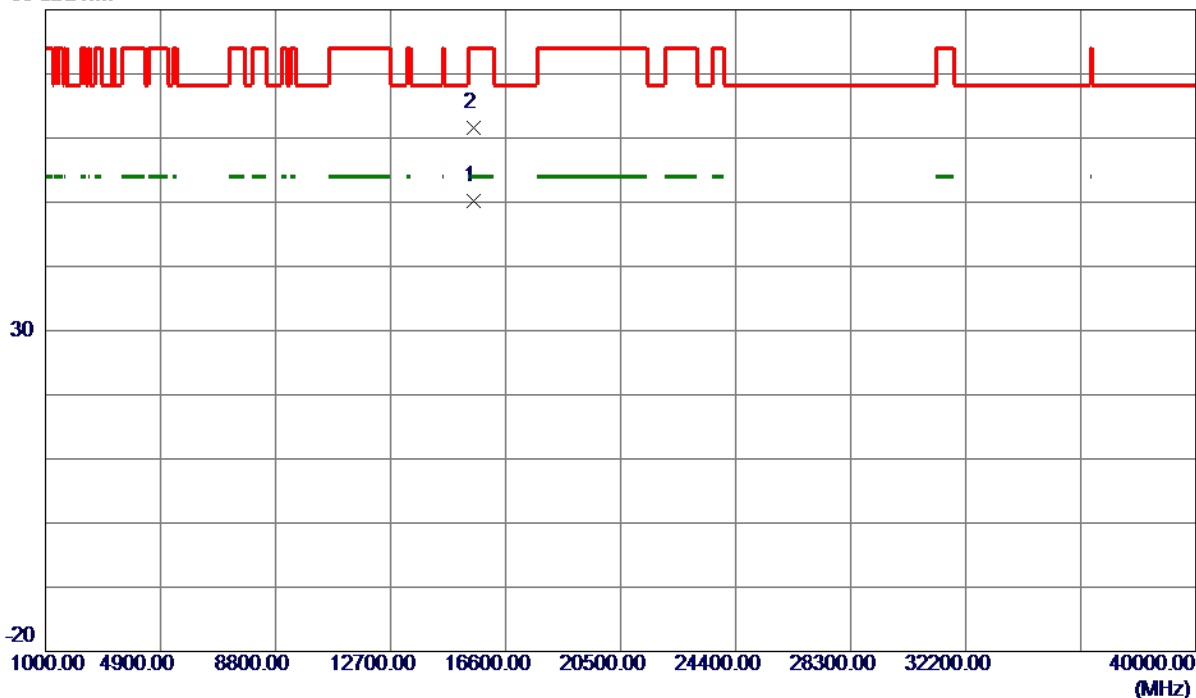

No.	Freq. MHz	Reading Level dBuV/m	Correct Factor dB	Measure ment dBuV/m	Limit dBuV/m	Margin dB	Detector	Comment
1 *	15535.1950	35.30	14.98	50.28	54.00	-3.72	AVG	
2	15535.8600	46.66	14.98	61.64	74.00	-12.36	Peak	

REMARKS:

- (1) Measurement Value = Reading Level + Correct Factor.
- (2) Margin Level = Measurement Value - Limit Value.

Orthogonal Axis	X
Test Mode	UNII-1_TX A Mode 5200 MHz

Vertical

130 dBuV/m

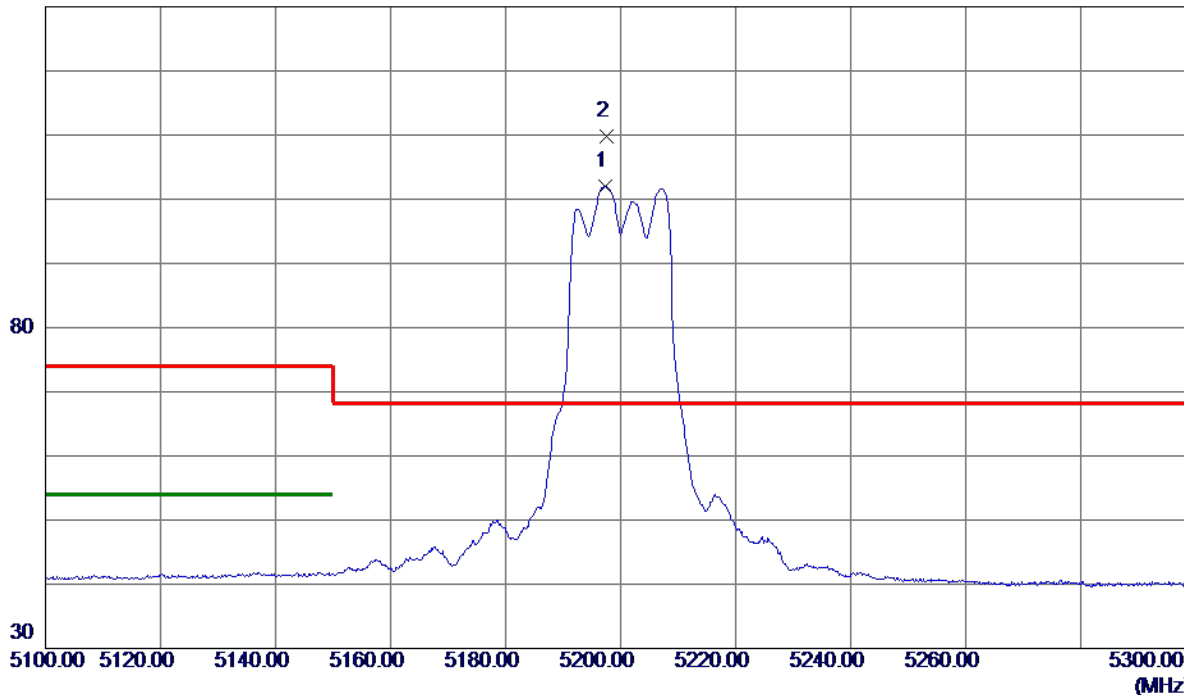

No.	Freq. MHz	Reading Level dBuV/m	Correct Factor dB	Measure ment dBuV/m	Limit dBuV/m	Margin dB	Detector	Comment
1	5197.4000	88.46	13.57	102.03	999.00	-896.97	AVG	No Limit
2 *	5197.5000	96.14	13.57	109.71	68.30	41.41	Peak	No Limit

REMARKS:

- (1) Measurement Value = Reading Level + Correct Factor.
- (2) Margin Level = Measurement Value - Limit Value.

Orthogonal Axis	X
Test Mode	UNII-1_TX A Mode 5200 MHz

Vertical

80 dBuV/m

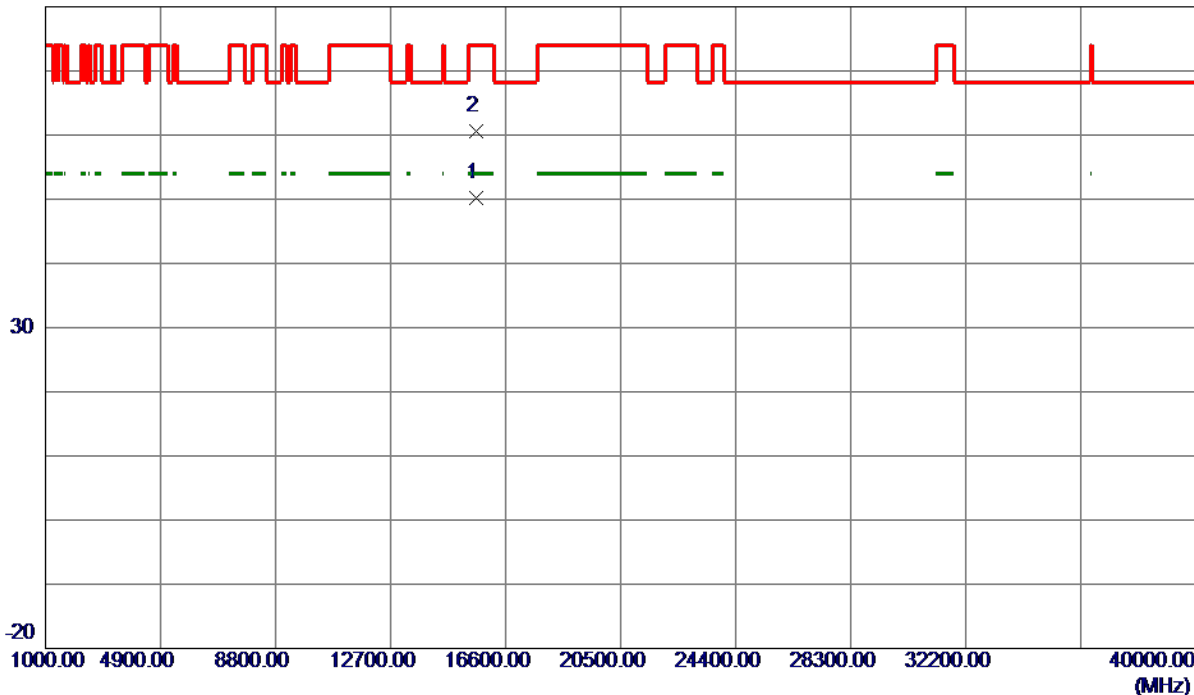

No.	Freq. MHz	Reading Level dBuV/m	Correct Factor dB	Measure ment dBuV/m	Limit dBuV/m	Margin dB	Detector	Comment
1 *	15596.6200	35.18	14.95	50.13	54.00	-3.87	AVG	
2	15604.7300	45.69	14.95	60.64	74.00	-13.36	Peak	

REMARKS:

- (1) Measurement Value = Reading Level + Correct Factor.
- (2) Margin Level = Measurement Value - Limit Value.

Orthogonal Axis	X
Test Mode	UNII-1_TX A Mode 5200 MHz

Horizontal

130 dBuV/m

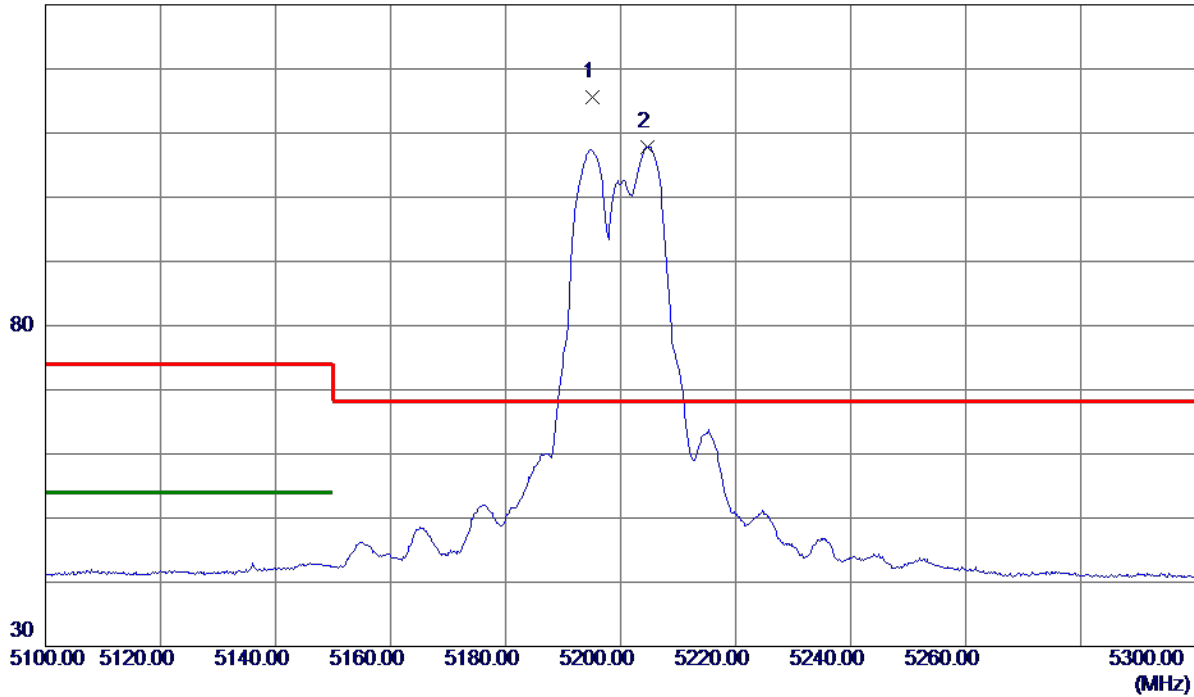

No.	Freq. MHz	Reading Level dBuV/m	Correct Factor dB	Measure ment dBuV/m	Limit dBuV/m	Margin dB	Detector	Comment
1 *	5195.1000	102.05	13.56	115.61	68.30	47.31	Peak	No Limit
2	5204.7000	94.29	13.59	107.88	999.00	-891.12	AVG	No Limit

REMARKS:

- (1) Measurement Value = Reading Level + Correct Factor.
- (2) Margin Level = Measurement Value - Limit Value.

Orthogonal Axis	X
Test Mode	UNII-1_TX A Mode 5200 MHz

Horizontal

80 dBuV/m

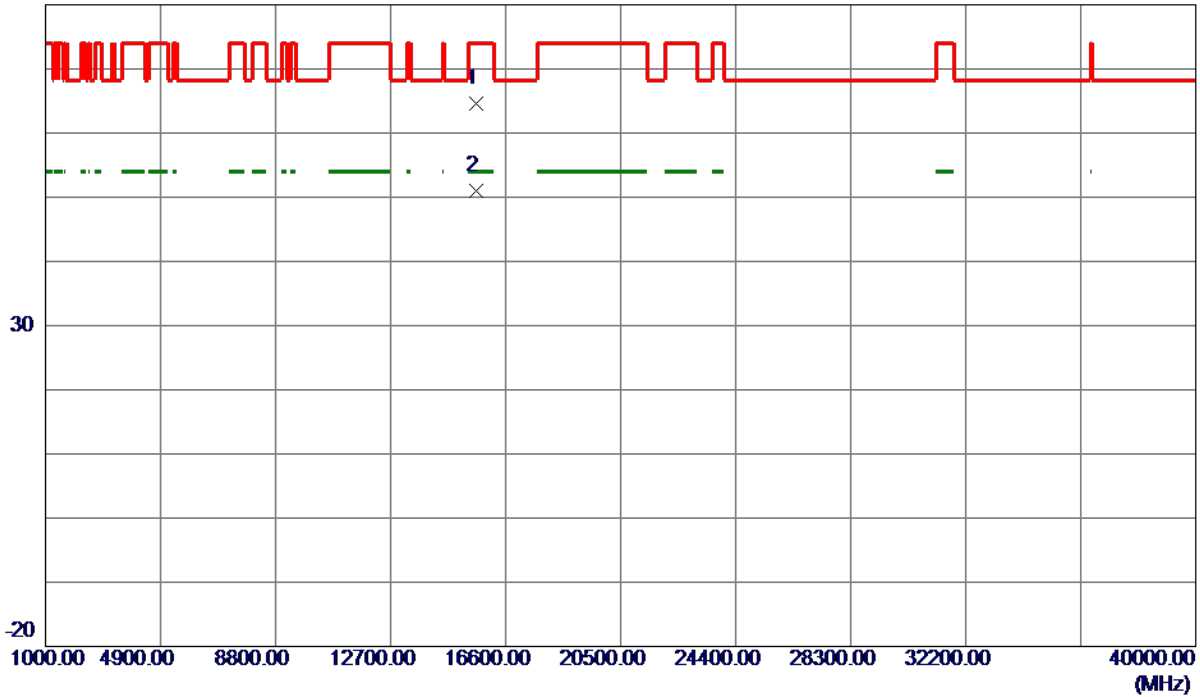

No.	Freq. MHz	Reading Level dBuV/m	Correct Factor dB	Measure ment dBuV/m	Limit dBuV/m	Margin dB	Detector	Comment
1	15595.0000	49.65	14.95	64.60	74.00	-9.40	Peak	
2 *	15595.2700	36.06	14.95	51.01	54.00	-2.99	AVG	

REMARKS:

- (1) Measurement Value = Reading Level + Correct Factor.
- (2) Margin Level = Measurement Value - Limit Value.

Orthogonal Axis	X
Test Mode	UNII-1_TX A Mode 5240 MHz

Vertical

130 dBuV/m

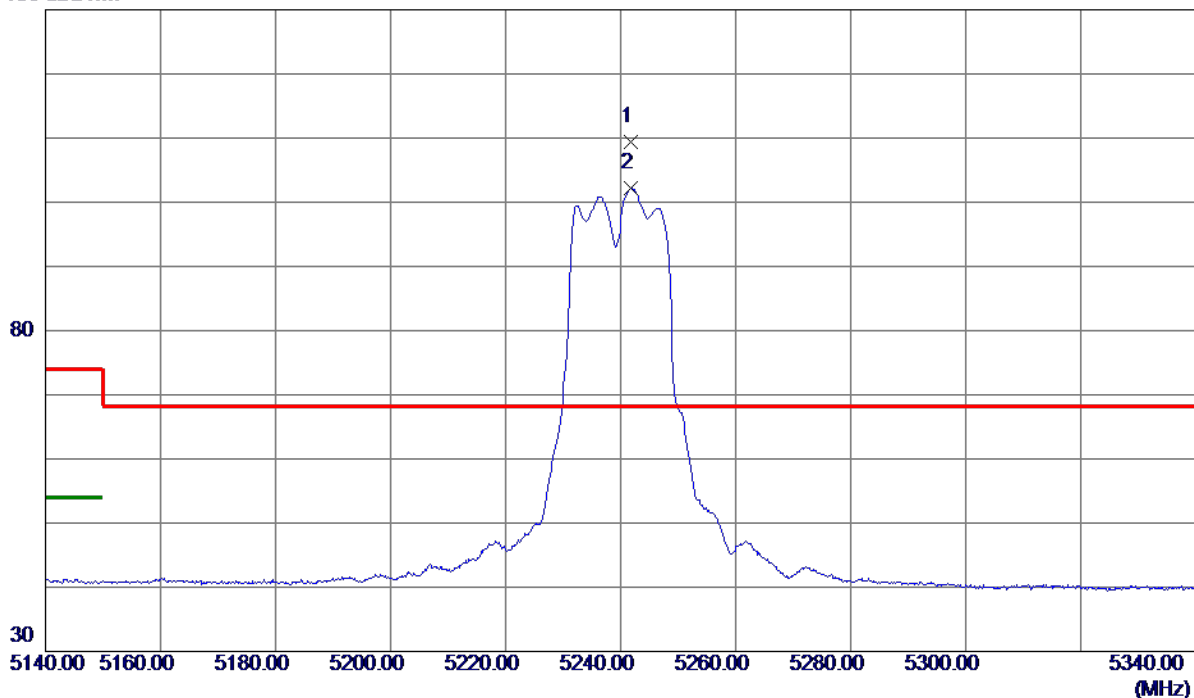

No.	Freq. MHz	Reading Level dBuV/m	Correct Factor dB	Measure ment dBuV/m	Limit dBuV/m	Margin dB	Detector	Comment
1 *	5241.7000	95.77	13.68	109.45	68.30	41.15	Peak	No Limit
2	5241.8000	88.49	13.68	102.17	999.00	-896.83	AVG	No Limit

REMARKS:

- (1) Measurement Value = Reading Level + Correct Factor.
- (2) Margin Level = Measurement Value - Limit Value.

Orthogonal Axis	X
Test Mode	UNII-1_TX A Mode 5240 MHz

Vertical

80 dBuV/m

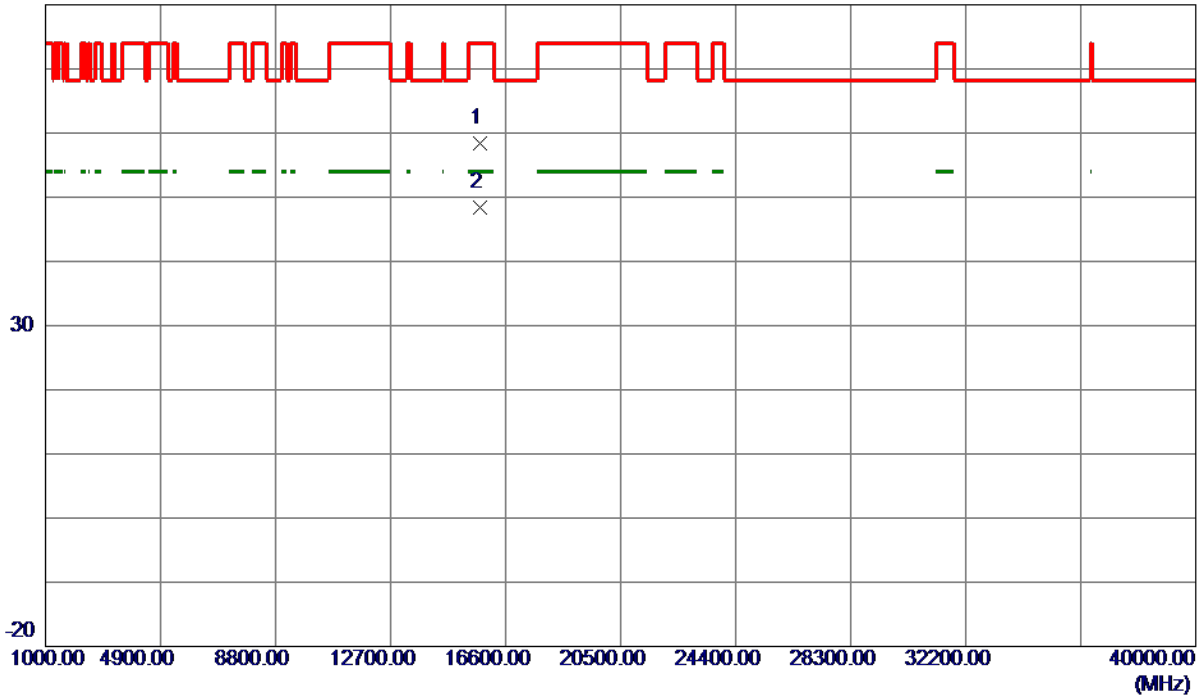

No.	Freq. MHz	Reading Level dBuV/m	Correct Factor dB	Measure ment dBuV/m	Limit dBuV/m	Margin dB	Detector	Comment
1	15716.1200	43.53	14.89	58.42	74.00	-15.58	Peak	
2 *	15716.7400	33.58	14.89	48.47	54.00	-5.53	AVG	

REMARKS:

- (1) Measurement Value = Reading Level + Correct Factor.
- (2) Margin Level = Measurement Value - Limit Value.

Orthogonal Axis	X
Test Mode	UNII-1_TX A Mode 5240 MHz

Horizontal

130 dBuV/m

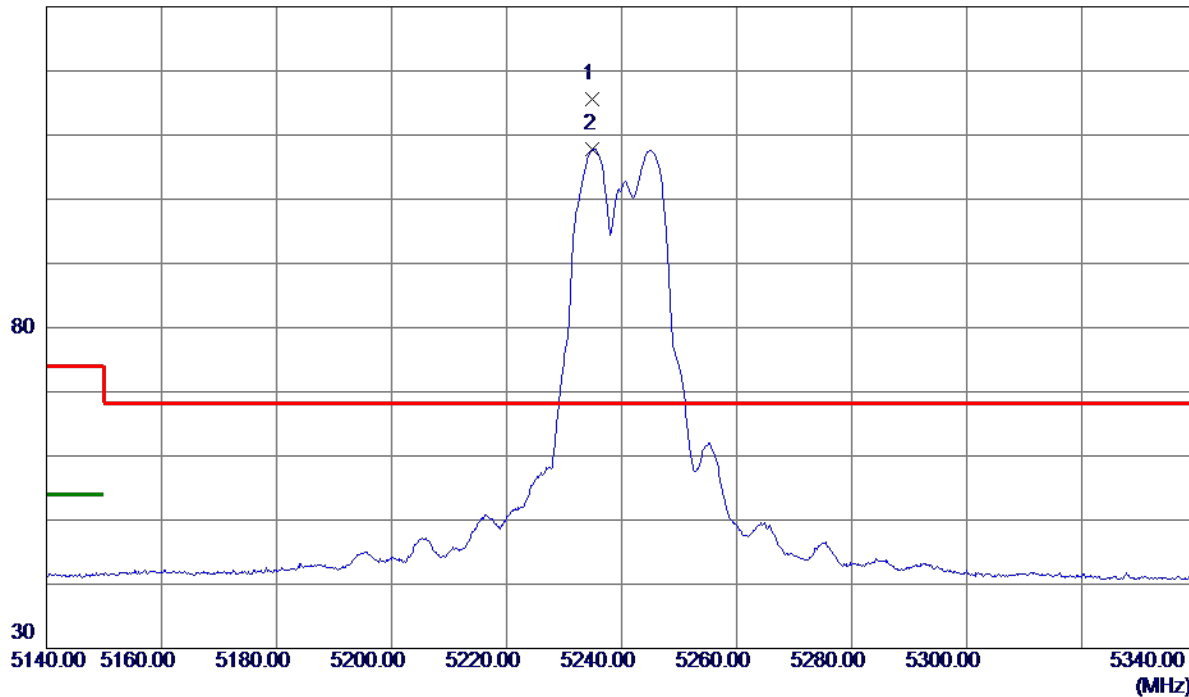

No.	Freq. MHz	Reading Level dBuV/m	Correct Factor dB	Measure ment dBuV/m	Limit dBuV/m	Margin dB	Detector	Comment
1 *	5234.8000	101.95	13.66	115.61	68.30	47.31	Peak	No Limit
2	5235.0000	94.12	13.66	107.78	999.00	-891.22	AVG	No Limit

REMARKS:

- (1) Measurement Value = Reading Level + Correct Factor.
- (2) Margin Level = Measurement Value - Limit Value.

Orthogonal Axis	X
Test Mode	UNII-1_TX A Mode 5240 MHz

Horizontal

80 dBuV/m

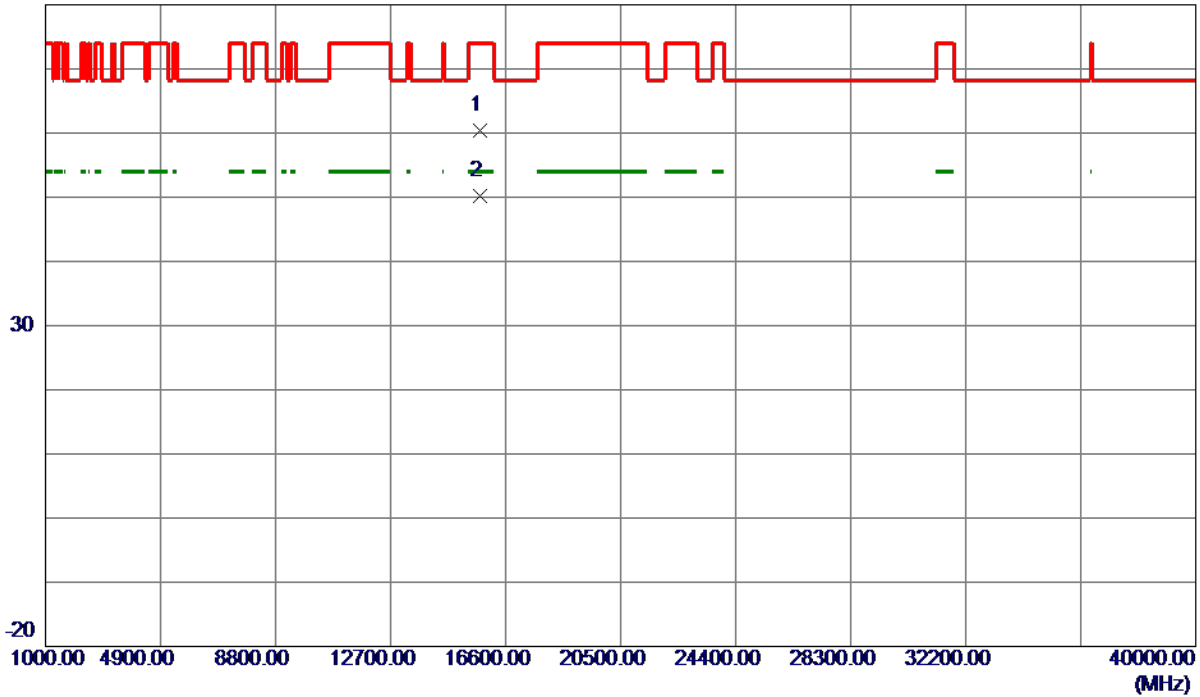

No.	Freq. MHz	Reading Level dBuV/m	Correct Factor dB	Measure ment dBuV/m	Limit dBuV/m	Margin dB	Detector	Comment
1	15715.1050	45.52	14.89	60.41	74.00	-13.59	Peak	
2 *	15724.1600	35.27	14.89	50.16	54.00	-3.84	AVG	

REMARKS:

- (1) Measurement Value = Reading Level + Correct Factor.
- (2) Margin Level = Measurement Value - Limit Value.

Orthogonal Axis	X
Test Mode	UNII-2A_TX A Mode 5260 MHz

Vertical

130 dBuV/m

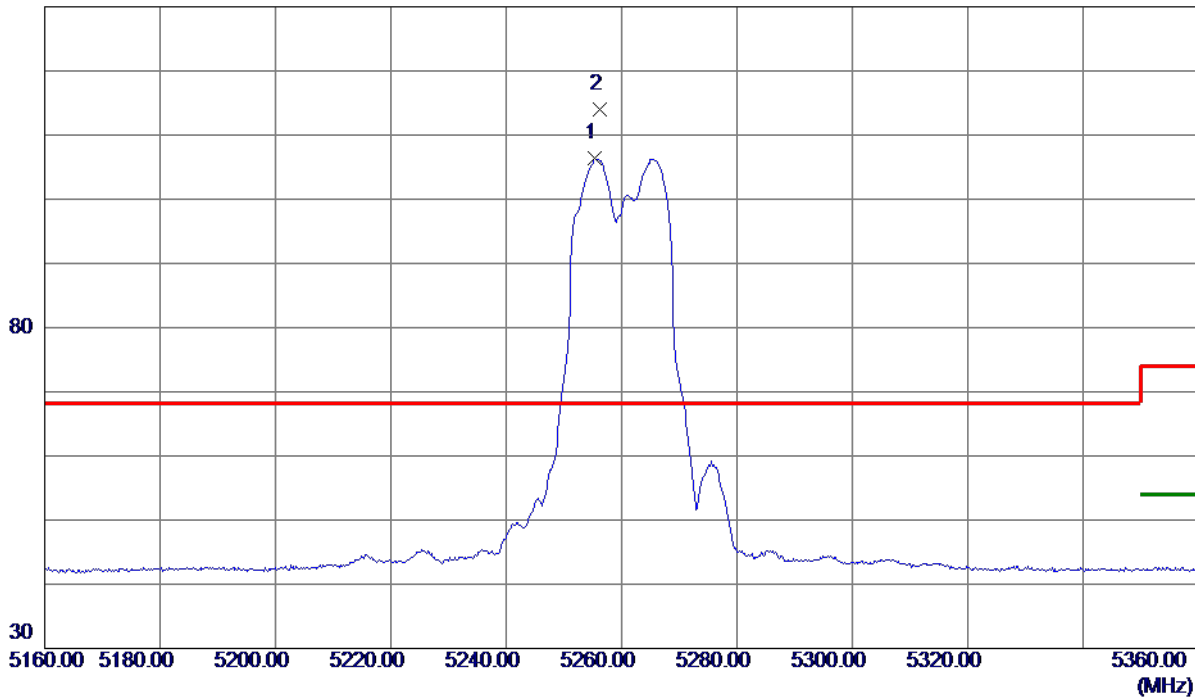

No.	Freq. MHz	Reading Level dBuV/m	Correct Factor dB	Measure ment dBuV/m	Limit dBuV/m	Margin dB	Detector	Comment
1	5255.4000	91.82	14.57	106.39	999.00	-892.61	AVG	No Limit
2 *	5256.2000	99.37	14.57	113.94	68.30	45.64	Peak	No Limit

REMARKS:

- (1) Measurement Value = Reading Level + Correct Factor.
- (2) Margin Level = Measurement Value - Limit Value.

Orthogonal Axis	X
Test Mode	UNII-2A_TX A Mode 5260 MHz

Vertical

80 dBuV/m

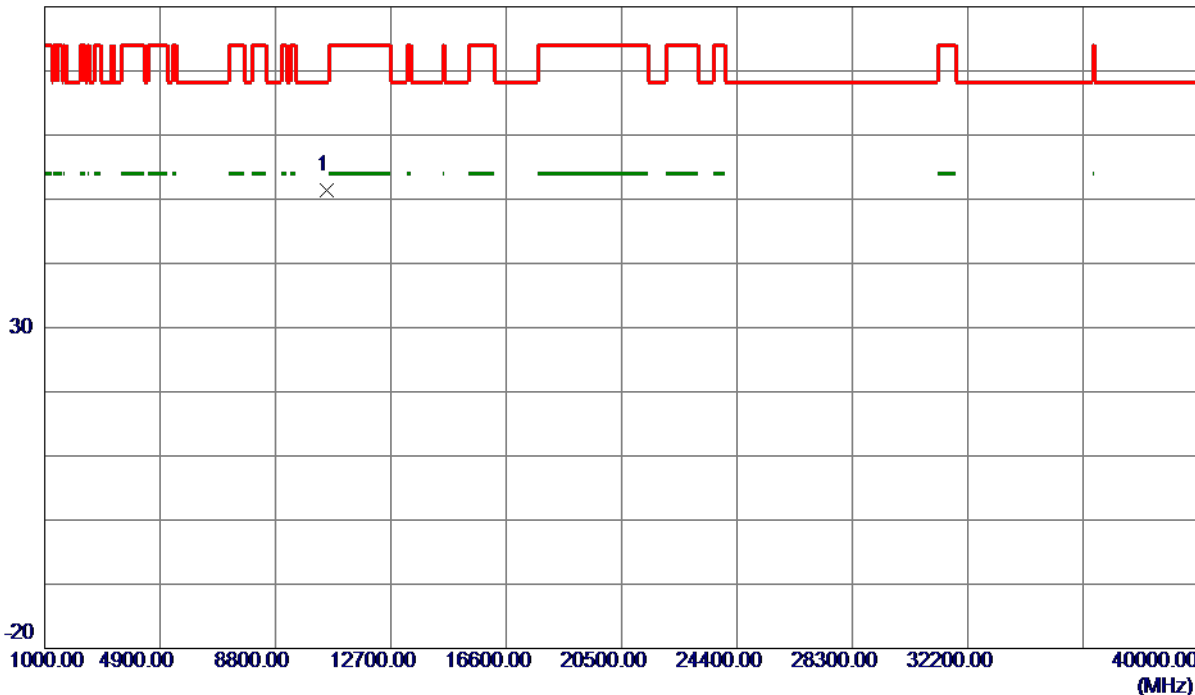

No.	Freq. MHz	Reading Level dBuV/m	Correct Factor dB	Measure ment dBuV/m	Limit dBuV/m	Margin dB	Detector	Comment
1 *	10515.6000	39.87	11.54	51.41	68.30	-16.89	Peak	

REMARKS:

- (1) Measurement Value = Reading Level + Correct Factor.
- (2) Margin Level = Measurement Value - Limit Value.

Orthogonal Axis	X
Test Mode	UNII-2A_TX A Mode 5260 MHz

Horizontal

130 dBuV/m

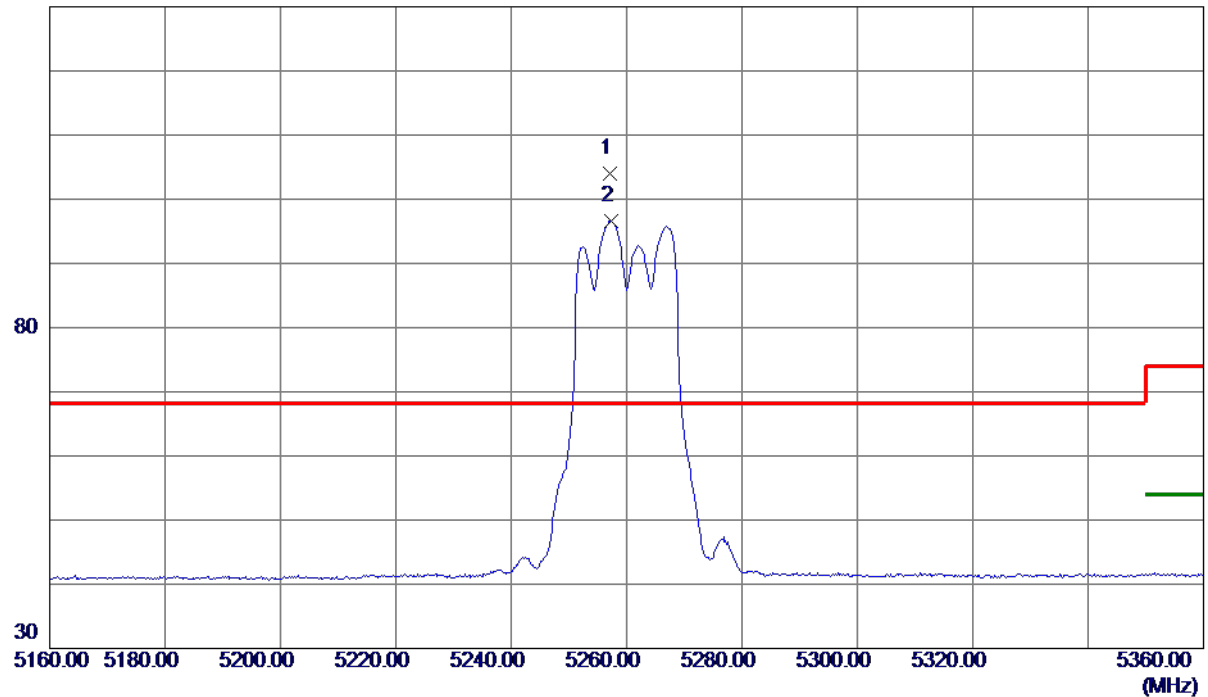

No.	Freq. MHz	Reading Level dBuV/m	Correct Factor dB	Measure ment dBuV/m	Limit dBuV/m	Margin dB	Detector	Comment
1 *	5257.2000	89.49	14.57	104.06	68.30	35.76	Peak	No Limit
2	5257.4000	81.99	14.57	96.56	999.00	-902.44	AVG	No Limit

REMARKS:

- (1) Measurement Value = Reading Level + Correct Factor.
- (2) Margin Level = Measurement Value - Limit Value.

Orthogonal Axis	X
Test Mode	UNII-2A_TX A Mode 5260 MHz

Horizontal

80 dBuV/m

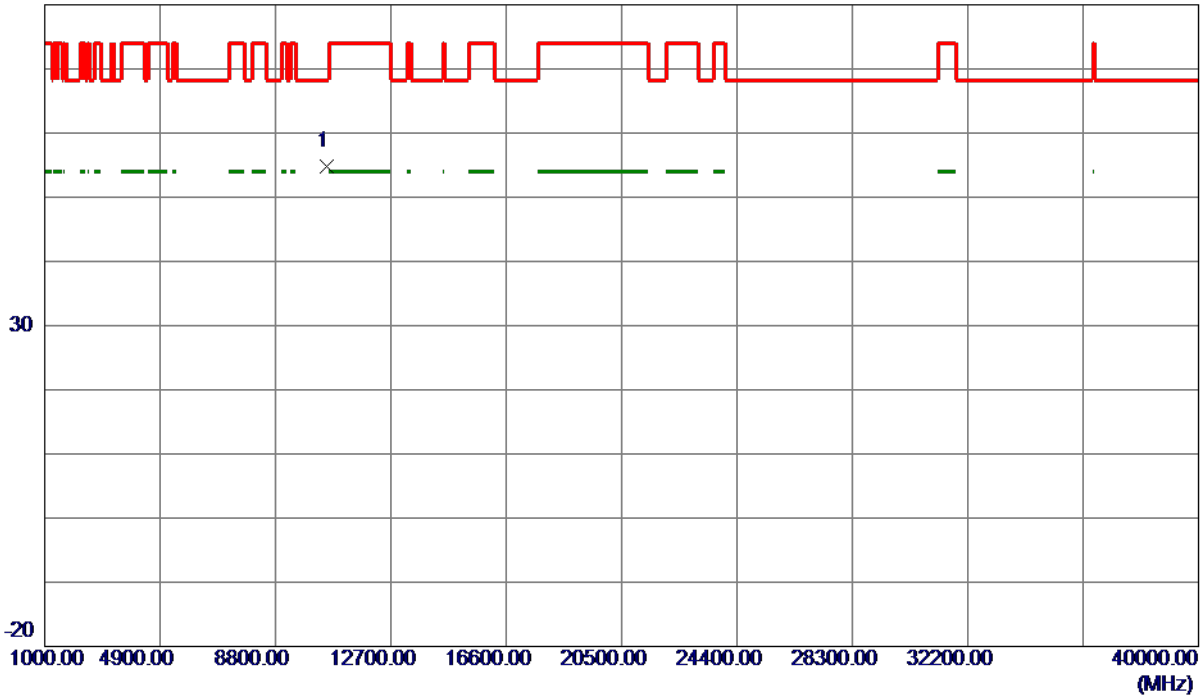

No.	Freq. MHz	Reading Level dBuV/m	Correct Factor dB	Measure ment dBuV/m	Limit dBuV/m	Margin dB	Detector	Comment
1 *	10519.0000	34.37	20.39	54.76	68.30	-13.54	Peak	

REMARKS:

- (1) Measurement Value = Reading Level + Correct Factor.
- (2) Margin Level = Measurement Value - Limit Value.

Orthogonal Axis	X
Test Mode	UNII-2A_TX A Mode 5300 MHz

Vertical

130 dBuV/m

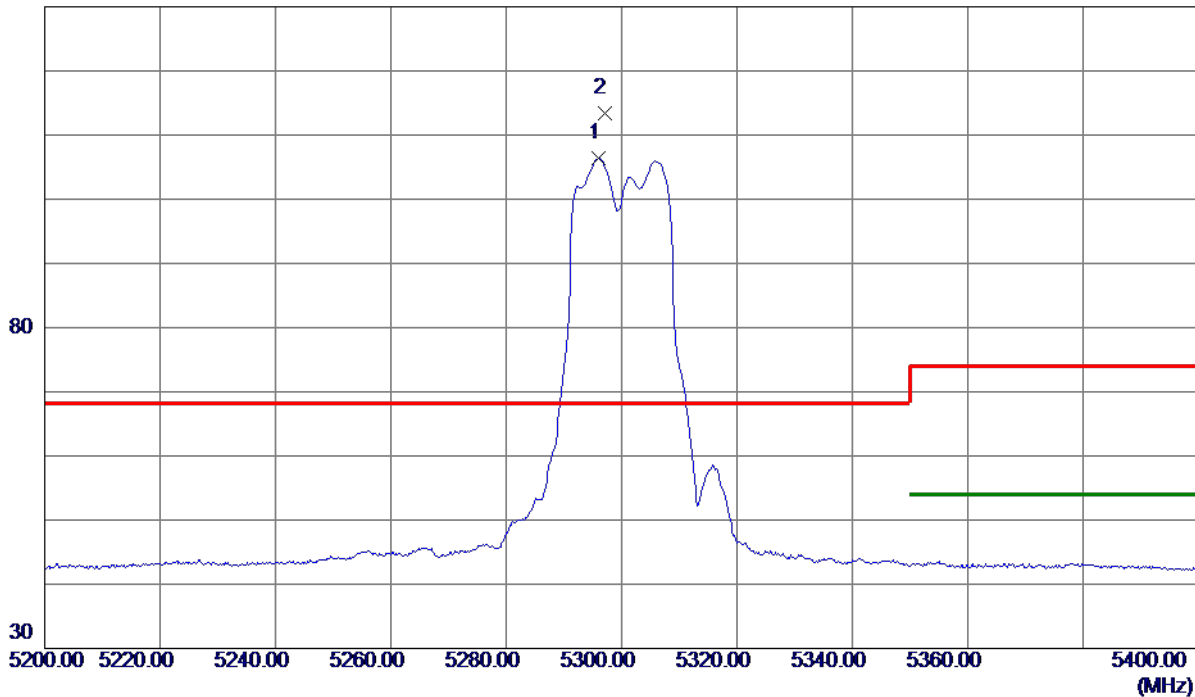

No.	Freq. MHz	Reading Level dBuV/m	Correct Factor dB	Measure ment dBuV/m	Limit dBuV/m	Margin dB	Detector	Comment
1	5296.0000	91.81	14.66	106.47	999.00	-892.53	AVG	No Limit
2 *	5297.0000	98.70	14.66	113.36	68.30	45.06	Peak	No Limit

REMARKS:

- (1) Measurement Value = Reading Level + Correct Factor.
- (2) Margin Level = Measurement Value - Limit Value.

Orthogonal Axis	X
Test Mode	UNII-2A_TX A Mode 5300 MHz

Vertical

80 dBuV/m

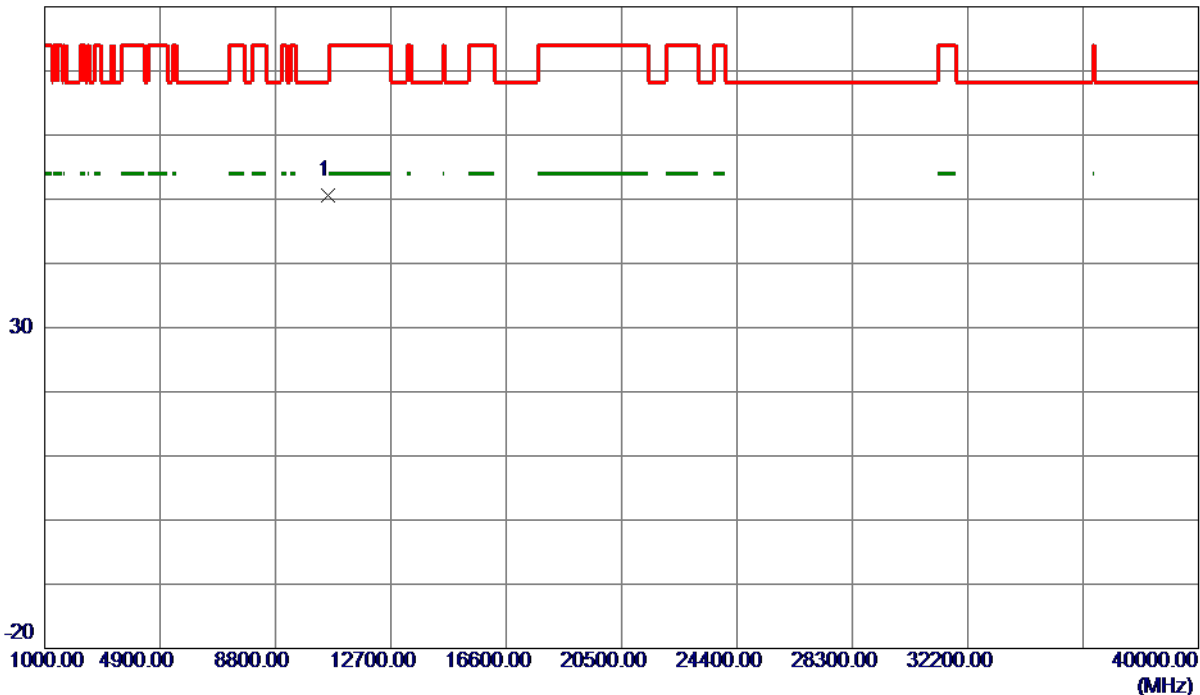

No.	Freq. MHz	Reading Level dBuV/m	Correct Factor dB	Measure ment dBuV/m	Limit dBuV/m	Margin dB	Detector	Comment
1 *	10596.4000	39.09	11.55	50.64	68.30	-17.66	Peak	

REMARKS:

- (1) Measurement Value = Reading Level + Correct Factor.
- (2) Margin Level = Measurement Value - Limit Value.

Orthogonal Axis	X
Test Mode	UNII-2A_TX A Mode 5300 MHz

Horizontal

130 dBuV/m

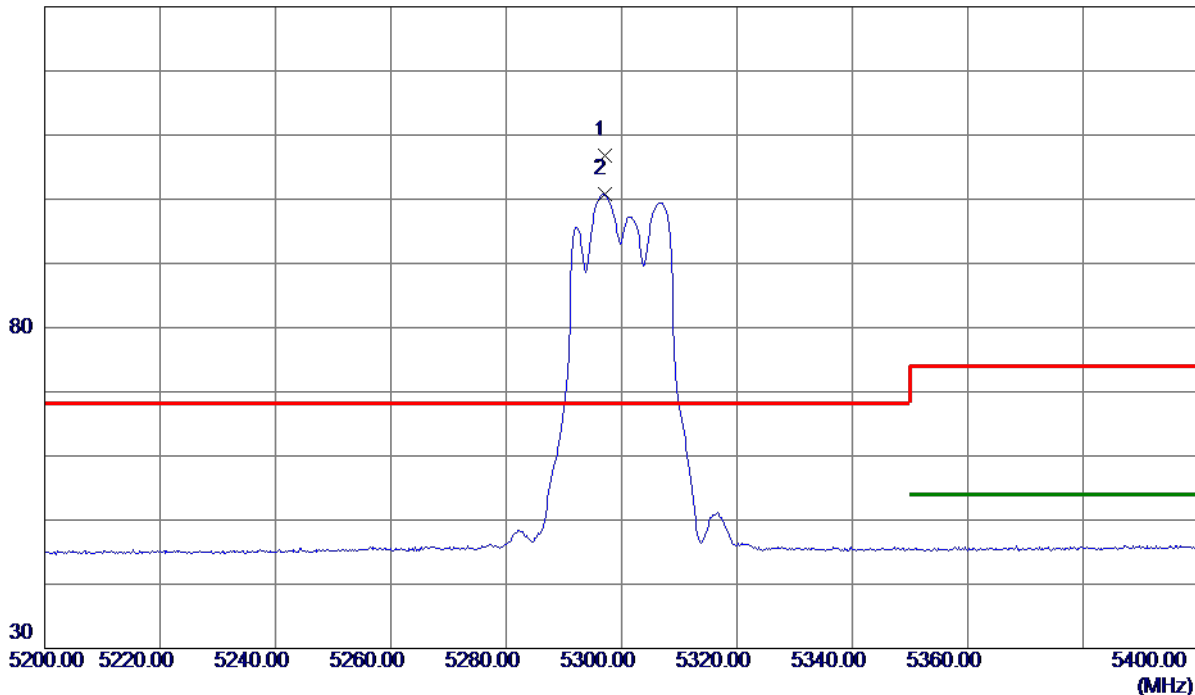

No.	Freq. MHz	Reading Level dBuV/m	Correct Factor dB	Measure ment dBuV/m	Limit dBuV/m	Margin dB	Detector	Comment
1 *	5297.0000	87.08	19.71	106.79	68.30	38.49	Peak	No Limit
2	5297.0000	81.07	19.71	100.78	999.00	-898.22	AVG	No Limit

REMARKS:

- (1) Measurement Value = Reading Level + Correct Factor.
- (2) Margin Level = Measurement Value - Limit Value.

Orthogonal Axis	X
Test Mode	UNII-2A_TX A Mode 5300 MHz

Horizontal

80 dBuV/m

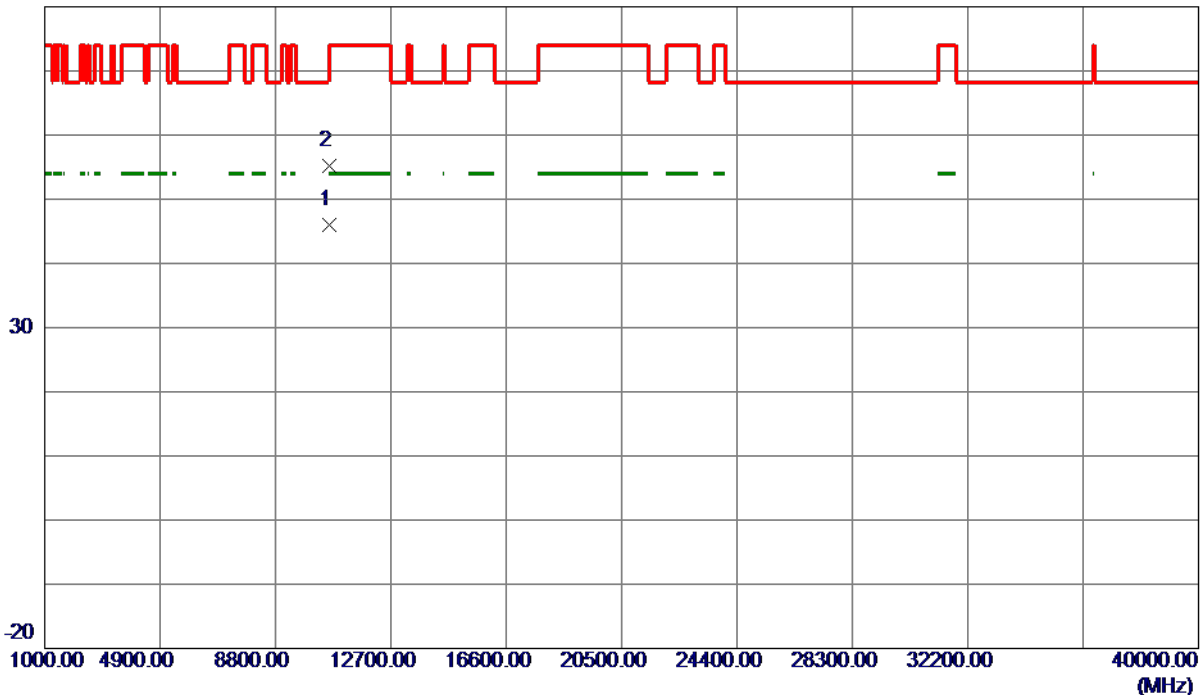

No.	Freq. MHz	Reading Level dBuV/m	Correct Factor dB	Measure ment dBuV/m	Limit dBuV/m	Margin dB	Detector	Comment
1 *	10604.2600	25.48	20.44	45.92	54.00	-8.08	AVG	
2	10607.2000	34.80	20.44	55.24	74.00	-18.76	Peak	

REMARKS:

- (1) Measurement Value = Reading Level + Correct Factor.
- (2) Margin Level = Measurement Value - Limit Value.

Orthogonal Axis	X
Test Mode	UNII-2A_TX A Mode 5320 MHz

Vertical

130 dBuV/m

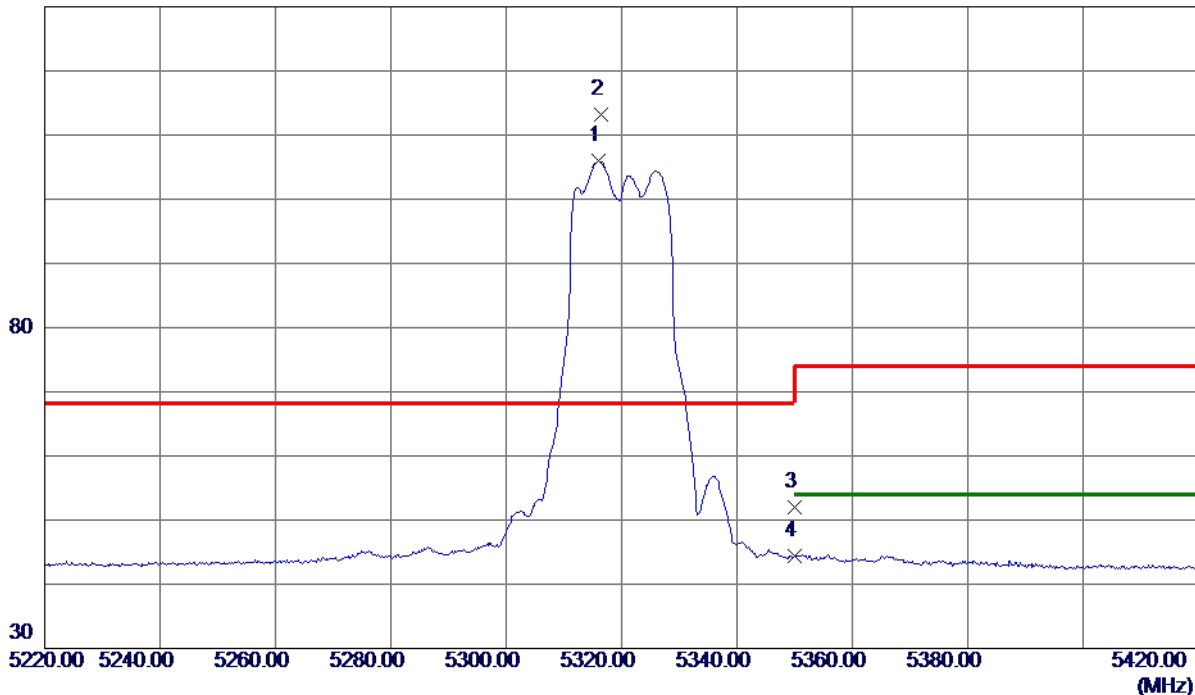

No.	Freq. MHz	Reading Level dBuV/m	Correct Factor dB	Measure ment dBuV/m	Limit dBuV/m	Margin dB	Detector	Comment
1	5316.0000	91.21	14.71	105.92	999.00	-893.08	AVG	No Limit
2 *	5316.4000	98.41	14.71	113.12	68.30	44.82	Peak	No Limit
3	5350.0000	37.27	14.79	52.06	74.00	-21.94	Peak	
4	5350.0000	29.53	14.79	44.32	999.00	-954.68	AVG	

REMARKS:

- (1) Measurement Value = Reading Level + Correct Factor.
- (2) Margin Level = Measurement Value - Limit Value.

Orthogonal Axis	X
Test Mode	UNII-2A_TX A Mode 5320 MHz

Vertical

80 dBuV/m

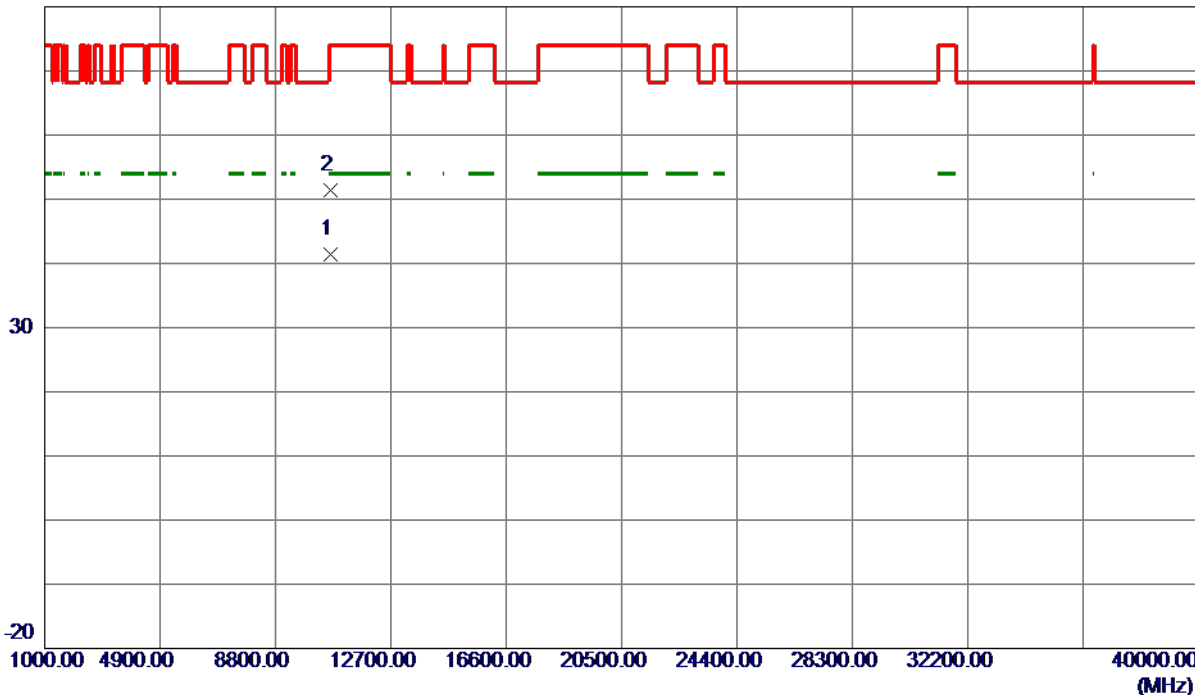

No.	Freq. MHz	Reading Level dBuV/m	Correct Factor dB	Measure ment dBuV/m	Limit dBuV/m	Margin dB	Detector	Comment
1 *	10642.0000	29.78	11.56	41.34	54.00	-12.66	AVG	
2	10644.4000	39.84	11.56	51.40	74.00	-22.60	Peak	

REMARKS:

- (1) Measurement Value = Reading Level + Correct Factor.
- (2) Margin Level = Measurement Value - Limit Value.

Orthogonal Axis	X
Test Mode	UNII-2A_TX A Mode 5320 MHz

Horizontal

130 dBuV/m

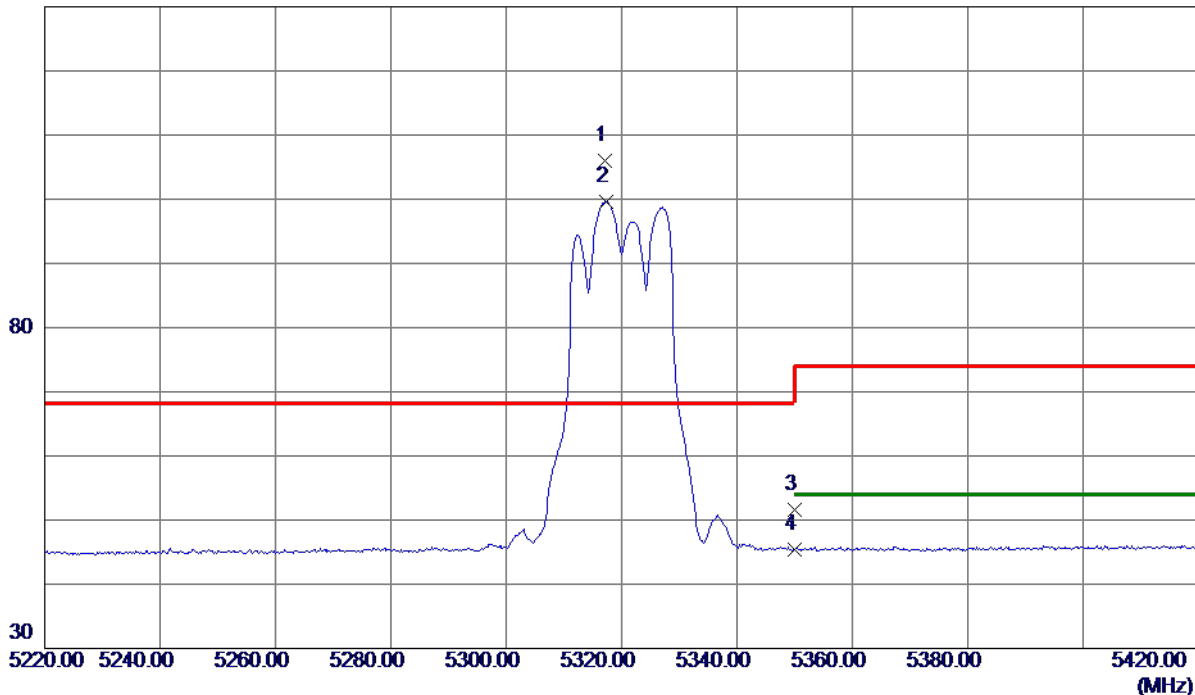

No.	Freq. MHz	Reading Level dBuV/m	Correct Factor dB	Measure ment dBuV/m	Limit dBuV/m	Margin dB	Detector	Comment
1 *	5317.2000	86.15	19.79	105.94	68.30	37.64	Peak	No Limit
2	5317.4000	79.87	19.79	99.66	999.00	-899.34	AVG	No Limit
3	5350.0000	31.76	19.91	51.67	74.00	-22.33	Peak	
4	5350.0000	25.52	19.91	45.43	999.00	-953.57	AVG	

REMARKS:

- (1) Measurement Value = Reading Level + Correct Factor.
- (2) Margin Level = Measurement Value - Limit Value.

Orthogonal Axis	X
Test Mode	UNII-2A_TX A Mode 5320 MHz

Horizontal

80 dBuV/m

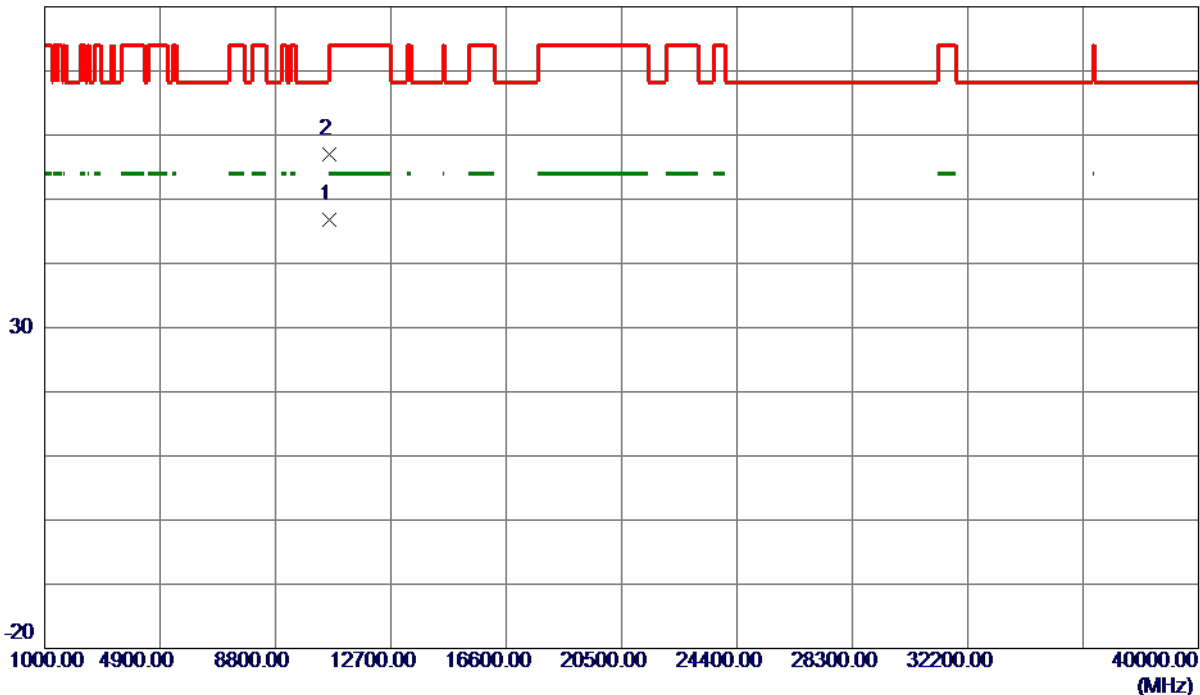

No.	Freq. MHz	Reading Level dBuV/m	Correct Factor dB	Measure ment dBuV/m	Limit dBuV/m	Margin dB	Detector	Comment
1 *	10639.1000	26.37	20.46	46.83	54.00	-7.17	AVG	
2	10640.4000	36.46	20.46	56.92	74.00	-17.08	Peak	

REMARKS:

- (1) Measurement Value = Reading Level + Correct Factor.
- (2) Margin Level = Measurement Value - Limit Value.

Orthogonal Axis	X
Test Mode	UNII-2C_TX A Mode 5500 MHz

Vertical

130 dBuV/m

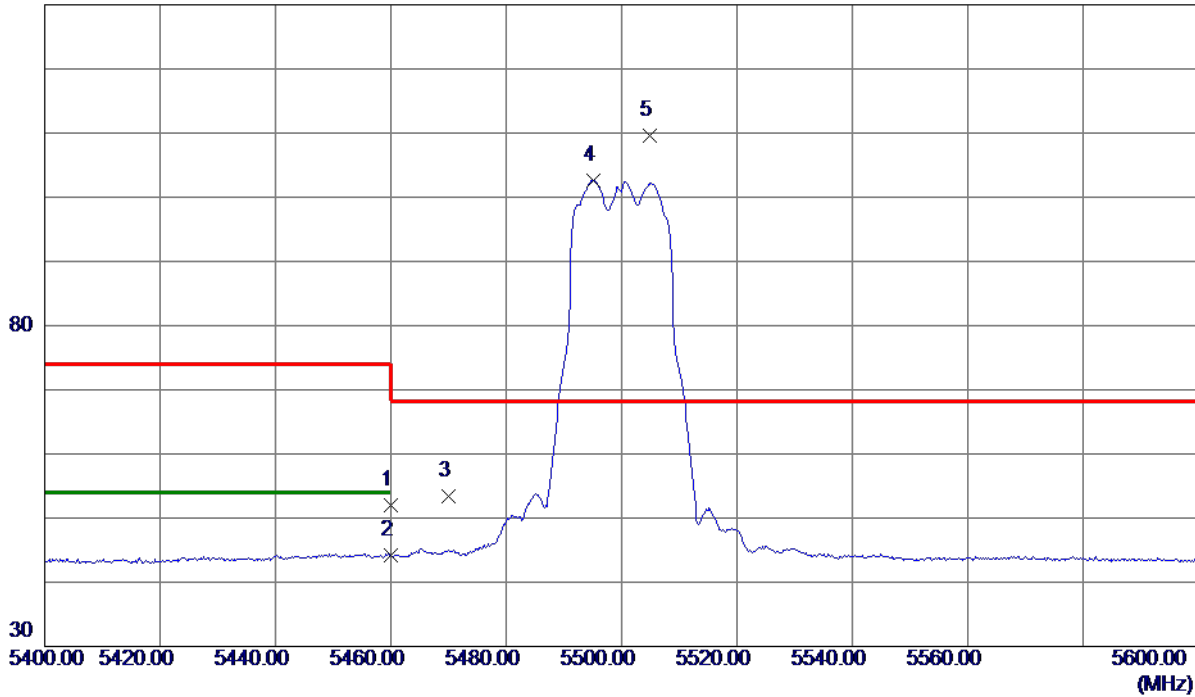

No.	Freq. MHz	Reading Level dBuV/m	Correct Factor dB	Measure ment dBuV/m	Limit dBuV/m	Margin dB	Detector	Comment
1	5460.0000	36.98	15.05	52.03	74.00	-21.97	Peak	
2	5460.0000	29.23	15.05	44.28	54.00	-9.72	AVG	
3	5470.0000	38.41	15.07	53.48	68.30	-14.82	Peak	
4	5495.2000	87.50	15.13	102.63	999.00	-896.37	AVG	No Limit
5 *	5504.8000	94.41	15.16	109.57	68.30	41.27	Peak	No Limit

REMARKS:

- (1) Measurement Value = Reading Level + Correct Factor.
- (2) Margin Level = Measurement Value - Limit Value.

Orthogonal Axis	X
Test Mode	UNII-2C_TX A Mode 5500 MHz

Vertical

80 dBuV/m

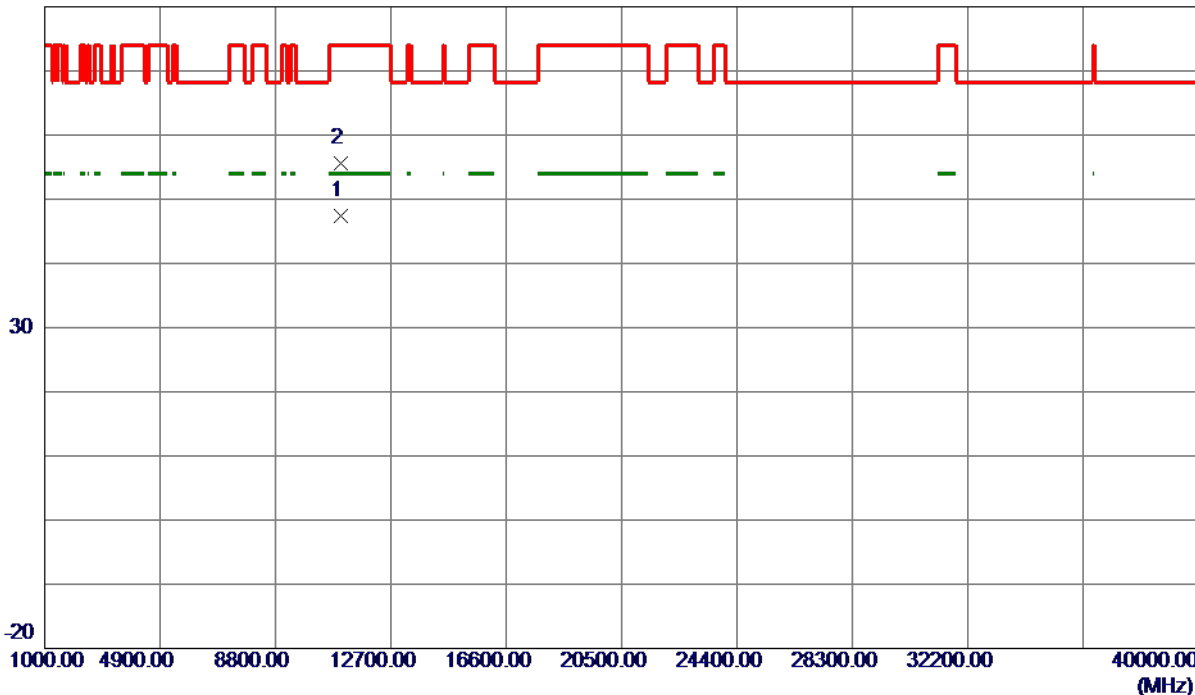

No.	Freq. MHz	Reading Level dBuV/m	Correct Factor dB	Measure ment dBuV/m	Limit dBuV/m	Margin dB	Detector	Comment
1 *	11001.6000	35.80	11.62	47.42	54.00	-6.58	AVG	
2	11003.2000	44.00	11.62	55.62	74.00	-18.38	Peak	

REMARKS:

- (1) Measurement Value = Reading Level + Correct Factor.
- (2) Margin Level = Measurement Value - Limit Value.

Orthogonal Axis	X
Test Mode	UNII-2C_TX A Mode 5500 MHz

Horizontal

130 dBuV/m

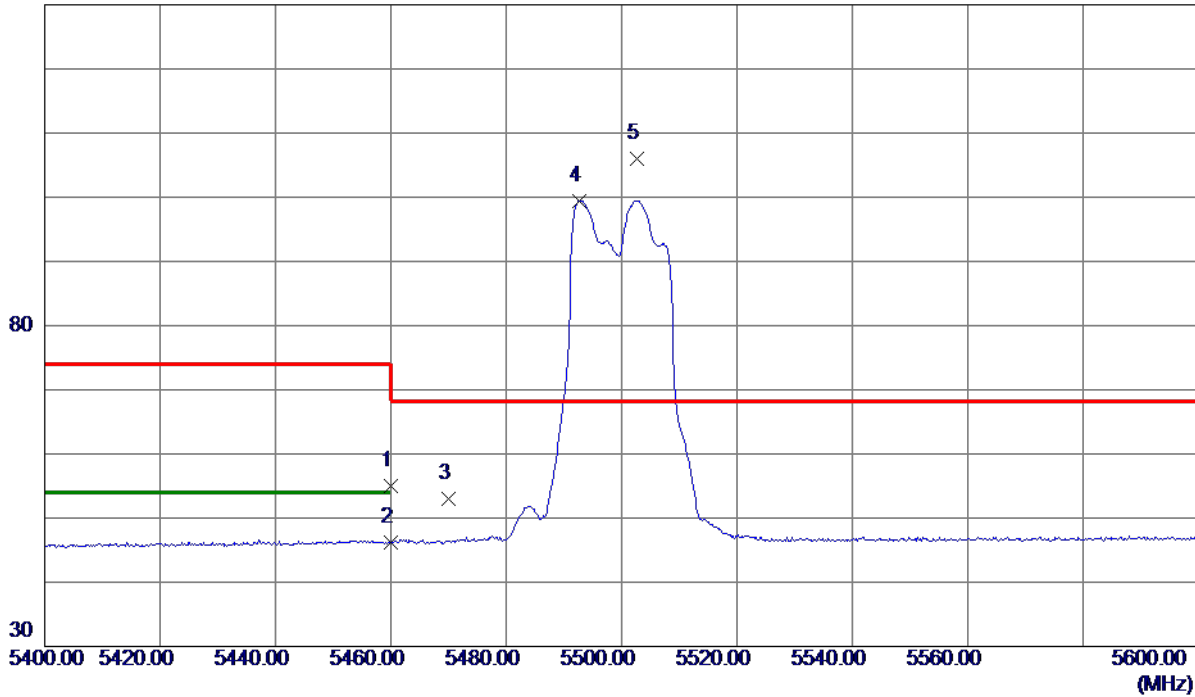

No.	Freq. MHz	Reading Level dBuV/m	Correct Factor dB	Measure ment dBuV/m	Limit dBuV/m	Margin dB	Detector	Comment
1	5460.0000	34.63	20.31	54.94	74.00	-19.06	Peak	
2	5460.0000	25.91	20.31	46.22	54.00	-7.78	AVG	
3	5470.0000	32.73	20.35	53.08	68.30	-15.22	Peak	
4	5492.6000	79.03	20.43	99.46	999.00	-899.54	AVG	No Limit
5 *	5502.6000	85.58	20.47	106.05	68.30	37.75	Peak	No Limit

REMARKS:

- (1) Measurement Value = Reading Level + Correct Factor.
- (2) Margin Level = Measurement Value - Limit Value.

Orthogonal Axis	X
Test Mode	UNII-2C_TX A Mode 5500 MHz

Horizontal

80 dBuV/m

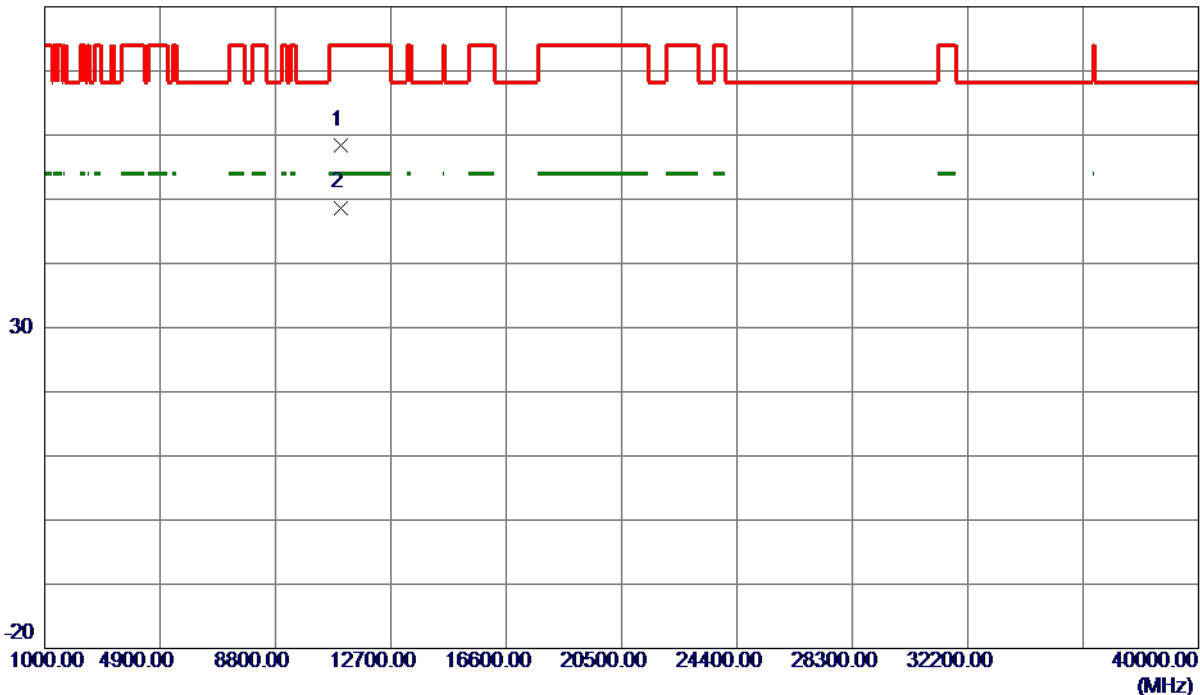

No.	Freq. MHz	Reading Level dBuV/m	Correct Factor dB	Measure ment dBuV/m	Limit dBuV/m	Margin dB	Detector	Comment
1	11000.5500	37.73	20.67	58.40	74.00	-15.60	Peak	
2 *	11000.9000	28.03	20.67	48.70	54.00	-5.30	AVG	

REMARKS:

- (1) Measurement Value = Reading Level + Correct Factor.
- (2) Margin Level = Measurement Value - Limit Value.

Orthogonal Axis	X
Test Mode	UNII-2C_TX A Mode 5580 MHz

Vertical

130 dBuV/m

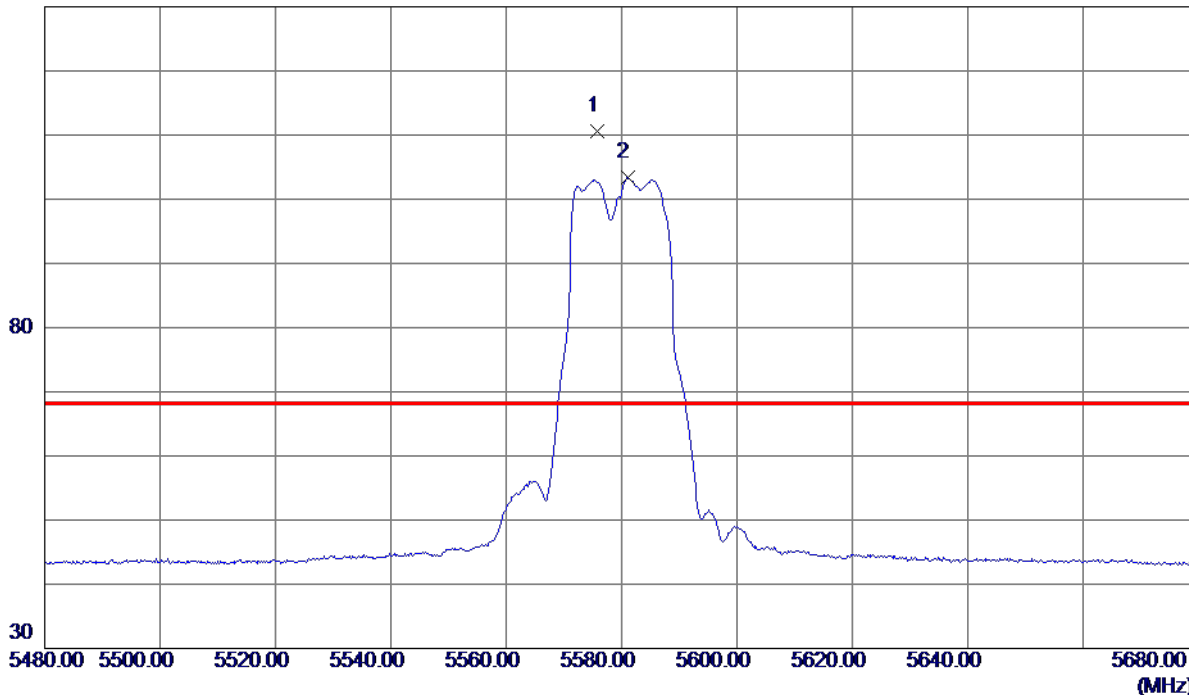

No.	Freq. MHz	Reading Level dBuV/m	Correct Factor dB	Measure ment dBuV/m	Limit dBuV/m	Margin dB	Detector	Comment
1 *	5575.8000	95.30	15.32	110.62	68.30	42.32	Peak	No Limit
2	5581.0000	87.97	15.34	103.31	999.00	-895.69	AVG	No Limit

REMARKS:

- (1) Measurement Value = Reading Level + Correct Factor.
- (2) Margin Level = Measurement Value - Limit Value.

Orthogonal Axis	X
Test Mode	UNII-2C_TX A Mode 5580 MHz

Vertical

80 dBuV/m

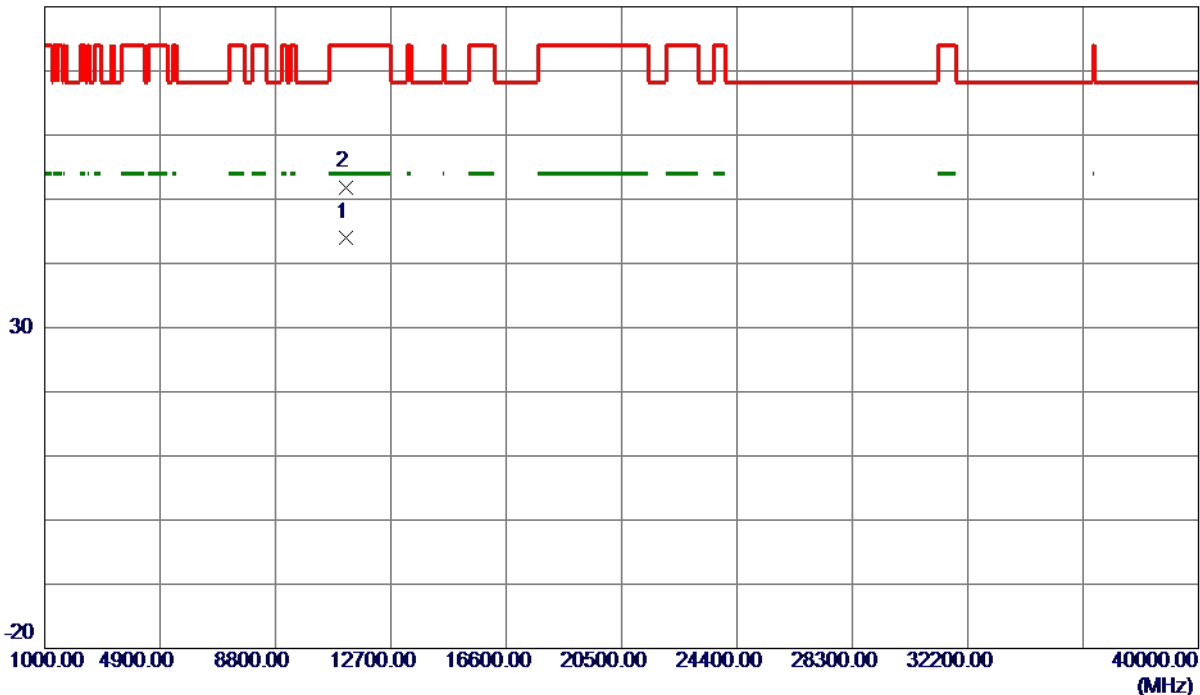

No.	Freq. MHz	Reading Level dBuV/m	Correct Factor dB	Measure ment dBuV/m	Limit dBuV/m	Margin dB	Detector	Comment
1 *	11173.4000	32.24	11.78	44.02	54.00	-9.98	AVG	
2	11172.6000	40.12	11.78	51.90	74.00	-22.10	Peak	

REMARKS:

- (1) Measurement Value = Reading Level + Correct Factor.
- (2) Margin Level = Measurement Value - Limit Value.

Orthogonal Axis	X
Test Mode	UNII-2C_TX A Mode 5580 MHz

Horizontal

130 dBuV/m

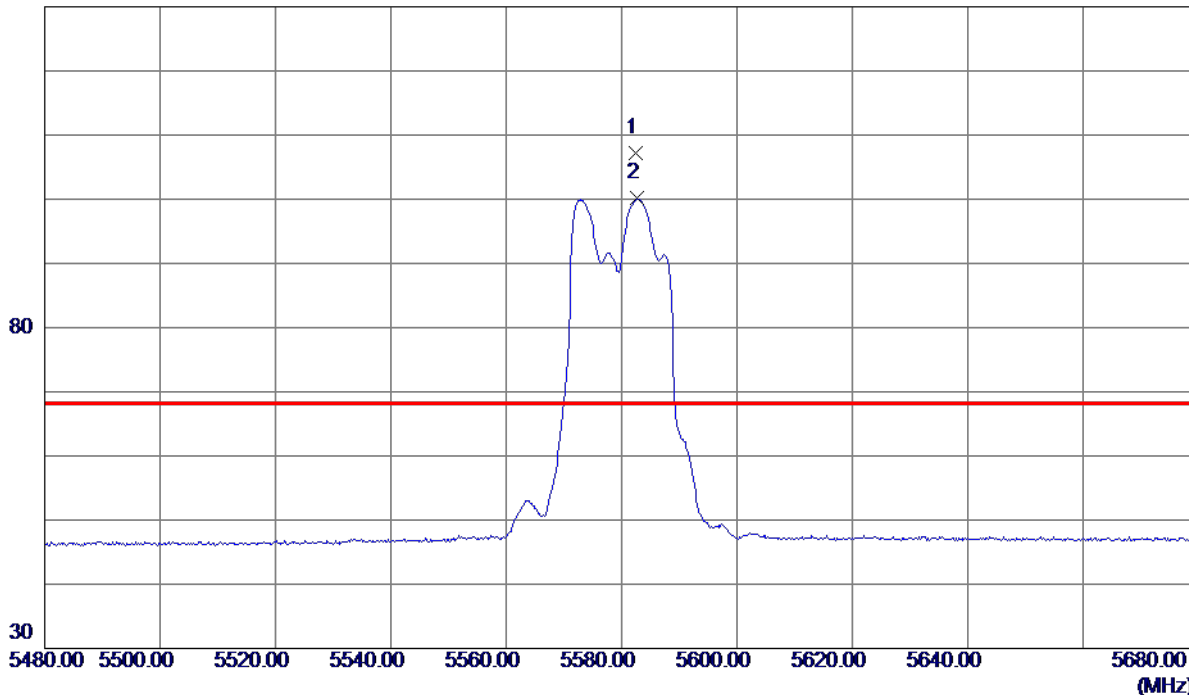

No.	Freq. MHz	Reading Level dBuV/m	Correct Factor dB	Measure ment dBuV/m	Limit dBuV/m	Margin dB	Detector	Comment
1 *	5582.4000	86.40	20.86	107.26	68.30	38.96	Peak	No Limit
2	5582.6000	79.25	20.86	100.11	999.00	-898.89	AVG	No Limit

REMARKS:

- (1) Measurement Value = Reading Level + Correct Factor.
- (2) Margin Level = Measurement Value - Limit Value.

Orthogonal Axis	X
Test Mode	UNII-2C_TX A Mode 5580 MHz

Horizontal

80 dBuV/m

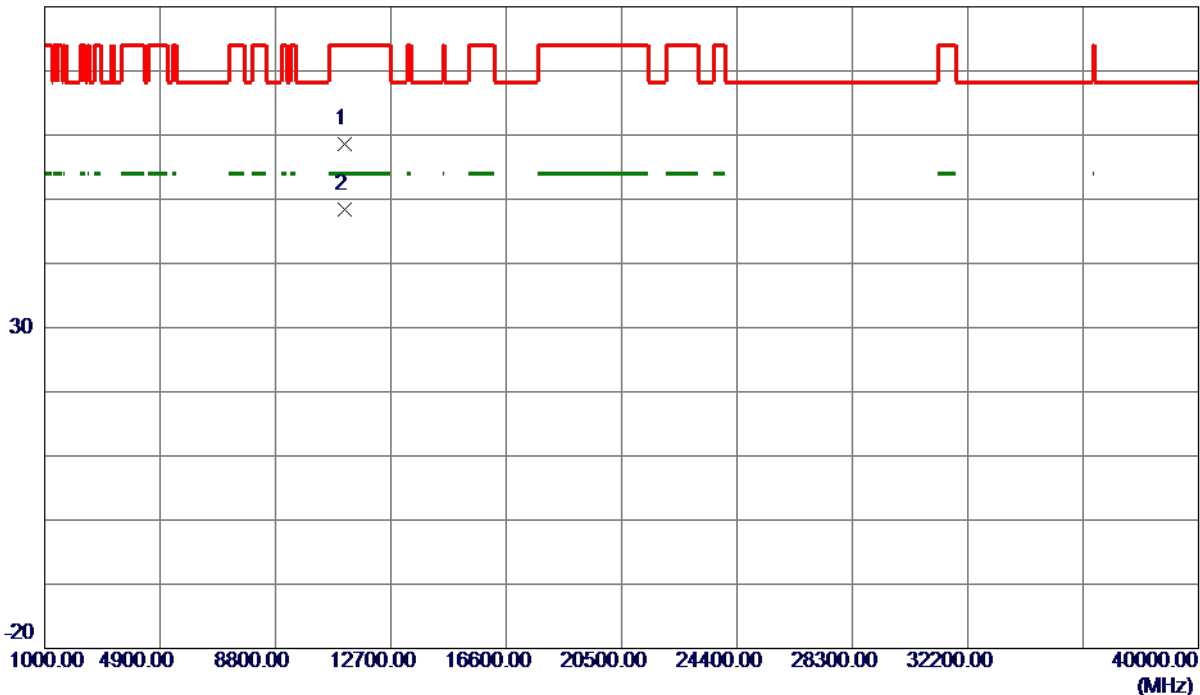

No.	Freq. MHz	Reading Level dBuV/m	Correct Factor dB	Measure ment dBuV/m	Limit dBuV/m	Margin dB	Detector	Comment
1	11160.1000	38.20	20.35	58.55	74.00	-15.45	Peak	
2 *	11161.0500	28.10	20.35	48.45	54.00	-5.55	AVG	

REMARKS:

- (1) Measurement Value = Reading Level + Correct Factor.
- (2) Margin Level = Measurement Value - Limit Value.

Orthogonal Axis	X
Test Mode	UNII-2C_TX A Mode 5700 MHz

Vertical

130 dBuV/m

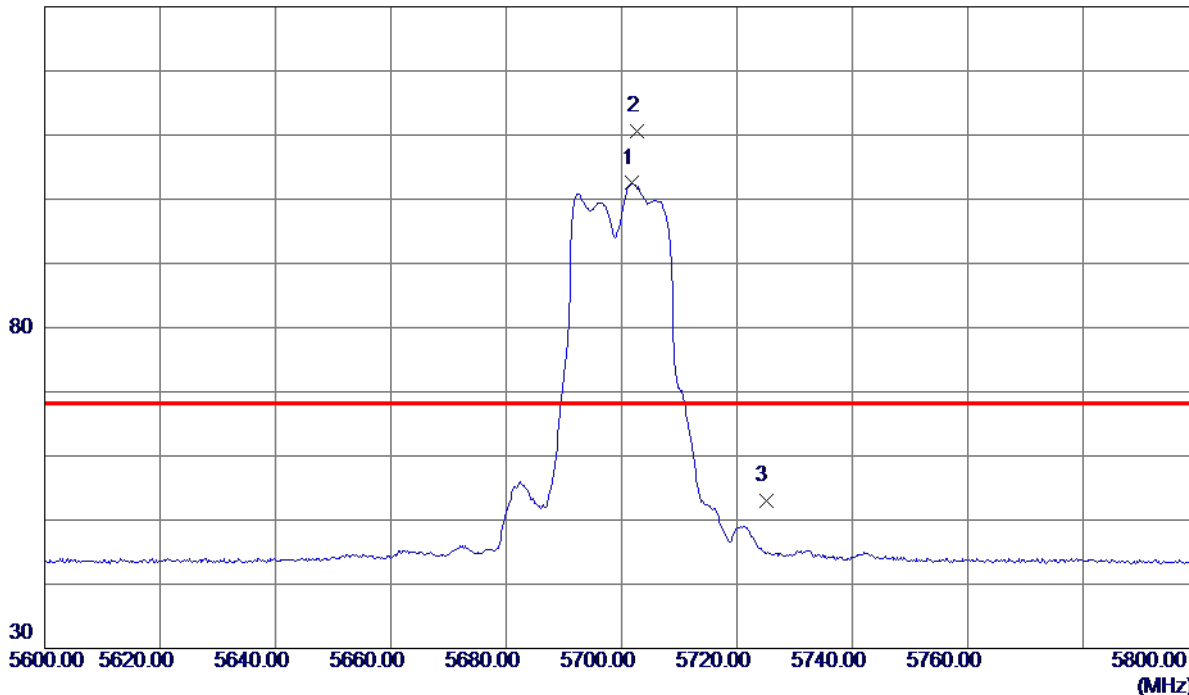

No.	Freq. MHz	Reading Level dBuV/m	Correct Factor dB	Measure ment dBuV/m	Limit dBuV/m	Margin dB	Detector	Comment
1	5701.8000	86.88	15.62	102.50	999.00	-896.50	AVG	No Limit
2 *	5702.6000	94.90	15.63	110.53	68.30	42.23	Peak	No Limit
3	5725.0000	37.35	15.68	53.03	68.30	-15.27	Peak	

REMARKS:

- (1) Measurement Value = Reading Level + Correct Factor.
- (2) Margin Level = Measurement Value - Limit Value.

Orthogonal Axis	X
Test Mode	UNII-2C_TX A Mode 5700 MHz

Vertical

80 dBuV/m



No.	Freq. MHz	Reading Level dBuV/m	Correct Factor dB	Measure ment dBuV/m	Limit dBuV/m	Margin dB	Detector	Comment
1	11403.8000	38.60	11.99	50.59	74.00	-23.41	Peak	
2 *	11403.8000	29.31	11.99	41.30	54.00	-12.70	AVG	

REMARKS:

- (1) Measurement Value = Reading Level + Correct Factor.
- (2) Margin Level = Measurement Value - Limit Value.

Orthogonal Axis	X
Test Mode	UNII-2C_TX A Mode 5700 MHz

Horizontal

130 dBuV/m

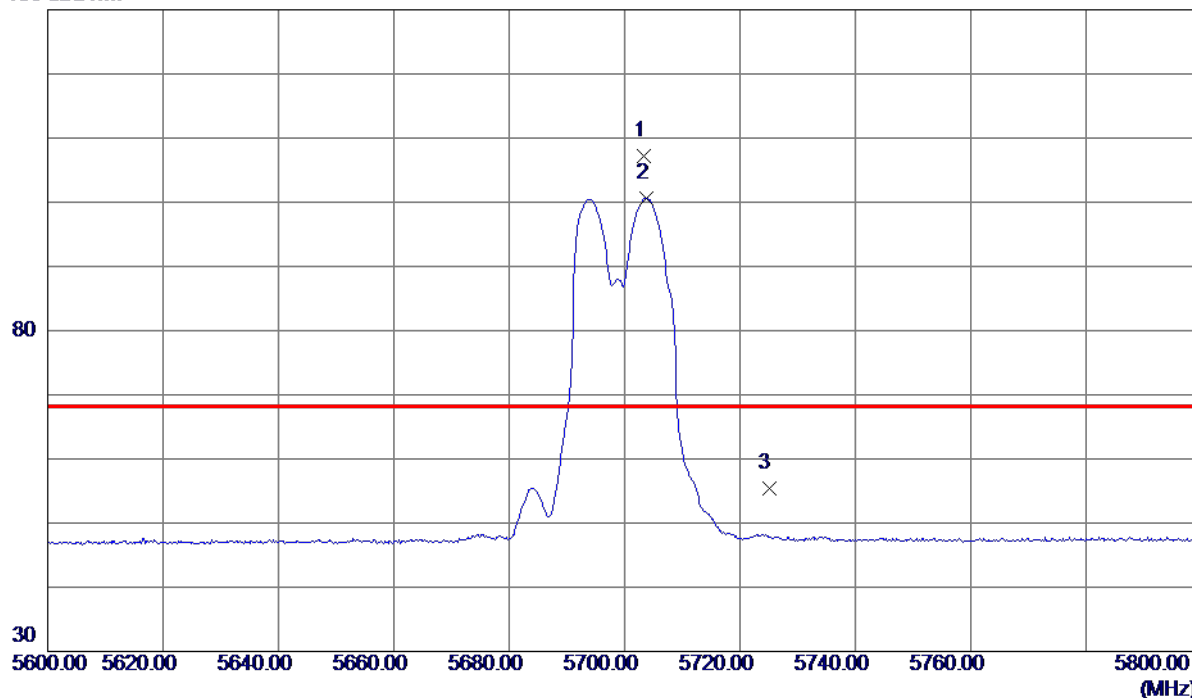

No.	Freq. MHz	Reading Level dBuV/m	Correct Factor dB	Measure ment dBuV/m	Limit dBuV/m	Margin dB	Detector	Comment
1 *	5703.4000	85.68	21.45	107.13	68.30	38.83	Peak	No Limit
2	5703.8000	79.20	21.45	100.65	999.00	-898.35	AVG	No Limit
3	5725.0000	33.81	21.55	55.36	68.30	-12.94	Peak	

REMARKS:

- (1) Measurement Value = Reading Level + Correct Factor.
- (2) Margin Level = Measurement Value - Limit Value.

Orthogonal Axis	X
Test Mode	UNII-2C_TX A Mode 5700 MHz

Horizontal

80 dBuV/m

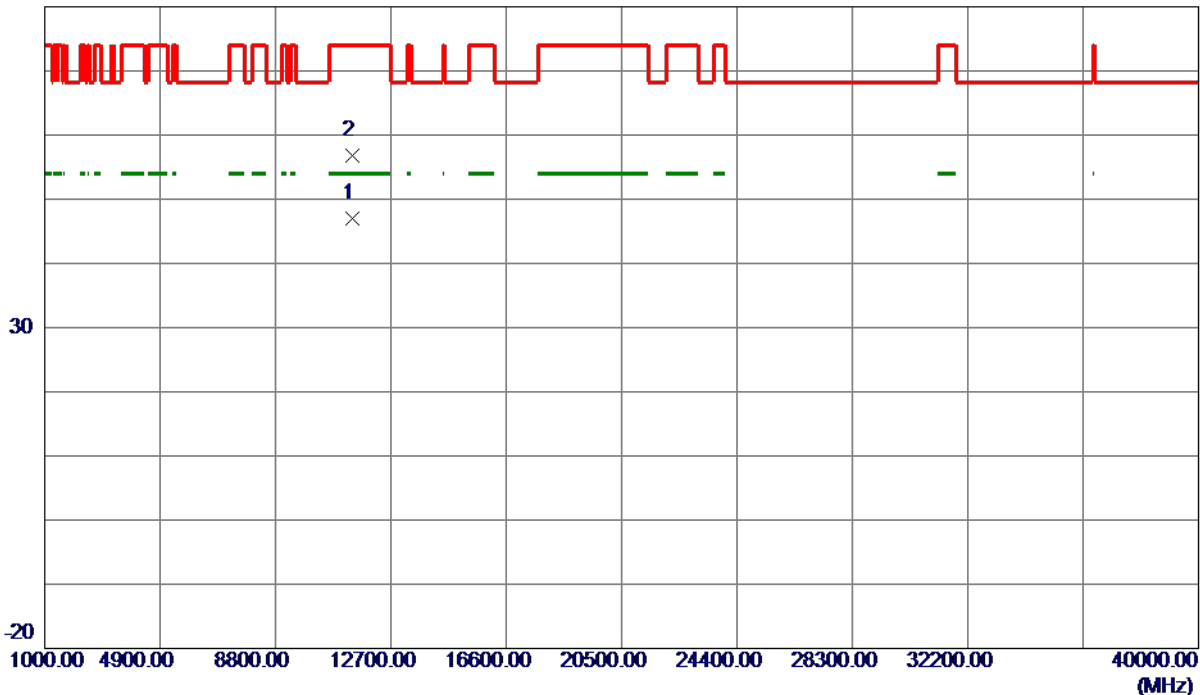

No.	Freq. MHz	Reading Level dBuV/m	Correct Factor dB	Measure ment dBuV/m	Limit dBuV/m	Margin dB	Detector	Comment
1 *	11399.1500	27.12	19.88	47.00	54.00	-7.00	AVG	
2	11408.9000	36.85	19.86	56.71	74.00	-17.29	Peak	

REMARKS:

- (1) Measurement Value = Reading Level + Correct Factor.
- (2) Margin Level = Measurement Value - Limit Value.

Orthogonal Axis	X
Test Mode	UNII-3_TX A Mode 5745 MHz

Vertical

130 dBuV/m

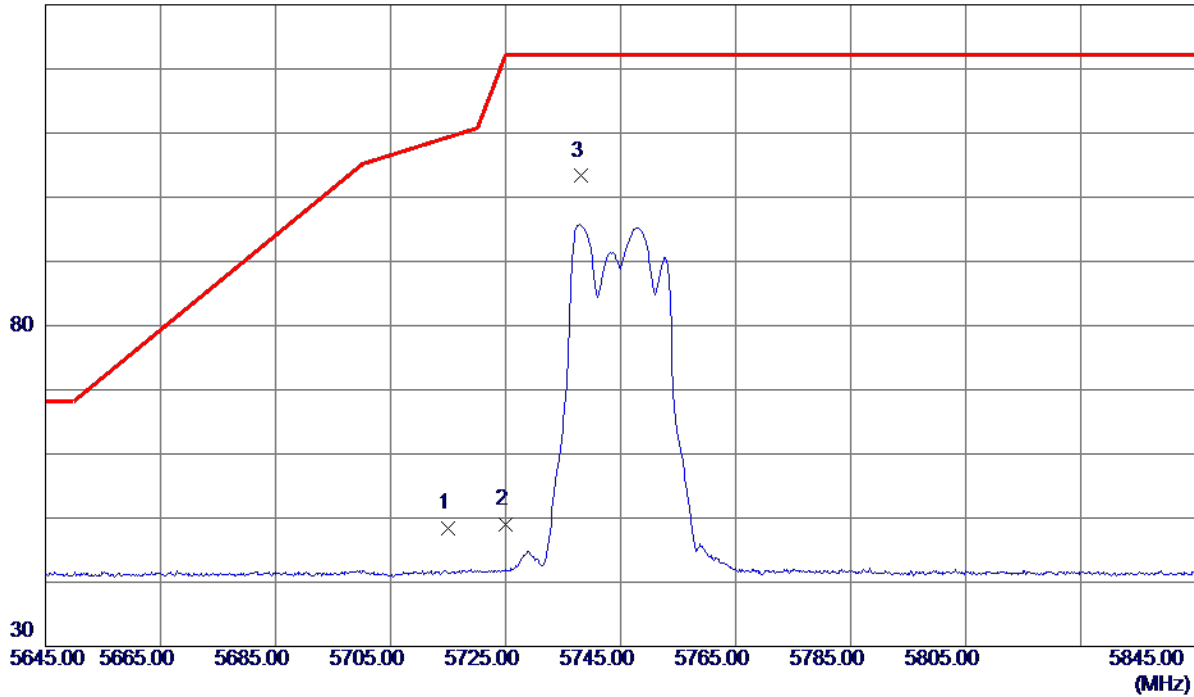

No.	Freq. MHz	Reading Level dBuV/m	Correct Factor dB	Measure ment dBuV/m	Limit dBuV/m	Margin dB	Detector	Comment
1	5715.0000	33.52	14.90	48.42	109.40	-60.98	Peak	
2	5725.0000	34.03	14.92	48.95	122.20	-73.25	Peak	
3 *	5738.2000	88.34	14.96	103.30	122.20	-18.90	Peak	No Limit

REMARKS:

- (1) Measurement Value = Reading Level + Correct Factor.
- (2) Margin Level = Measurement Value - Limit Value.

Orthogonal Axis	X
Test Mode	UNII-3_TX A Mode 5745 MHz

Vertical

80 dBuV/m

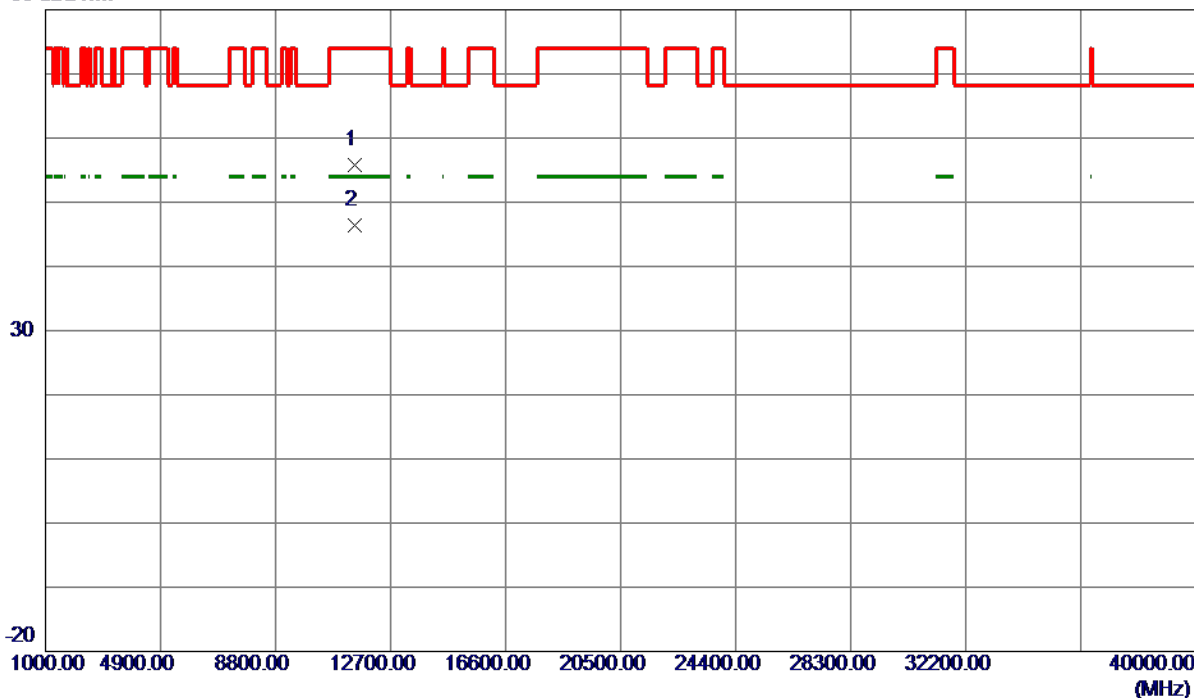

No.	Freq. MHz	Reading Level dBuV/m	Correct Factor dB	Measure ment dBuV/m	Limit dBuV/m	Margin dB	Detector	Comment
1	11488.6050	43.58	12.24	55.82	74.00	-18.18	Peak	
2 *	11488.6600	34.11	12.24	46.35	54.00	-7.65	AVG	

REMARKS:

- (1) Measurement Value = Reading Level + Correct Factor.
- (2) Margin Level = Measurement Value - Limit Value.

Orthogonal Axis	X
Test Mode	UNII-3_TX A Mode 5745 MHz

Horizontal

130 dBuV/m

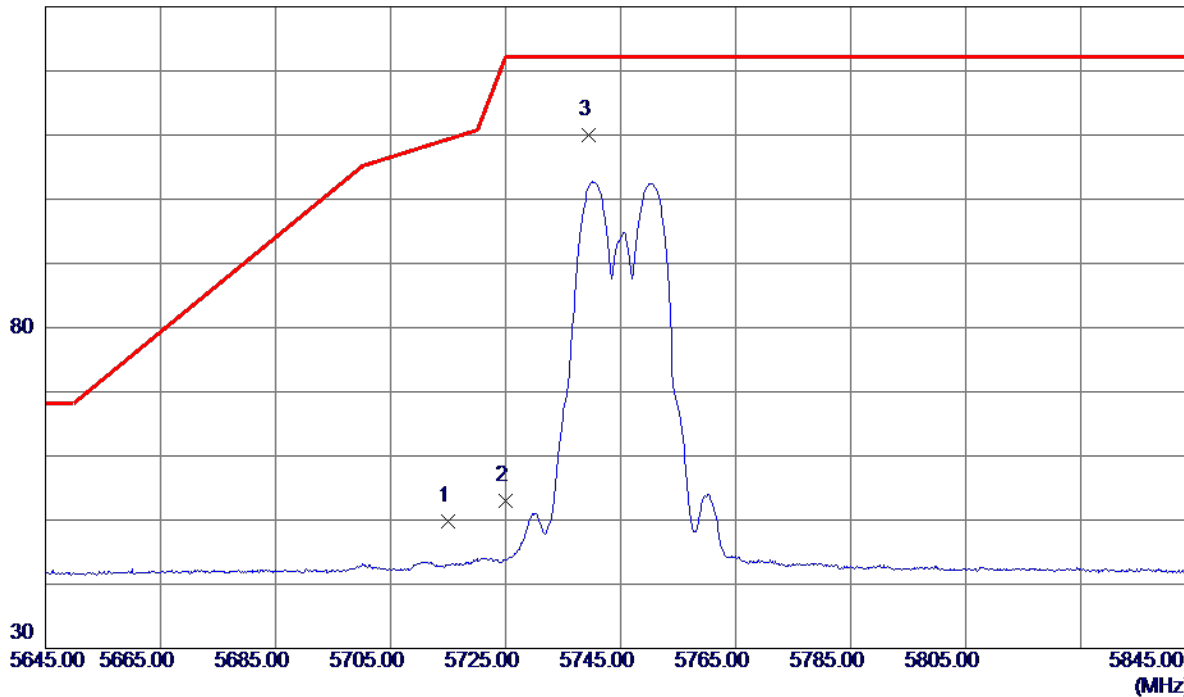

No.	Freq. MHz	Reading Level dBuV/m	Correct Factor dB	Measure ment dBuV/m	Limit dBuV/m	Margin dB	Detector	Comment
1	5715.0000	34.97	14.90	49.87	109.40	-59.53	Peak	
2	5725.0000	38.13	14.92	53.05	122.20	-69.15	Peak	
3 *	5739.5000	95.07	14.96	110.03	122.20	-12.17	Peak	No Limit

REMARKS:

- (1) Measurement Value = Reading Level + Correct Factor.
- (2) Margin Level = Measurement Value - Limit Value.

Orthogonal Axis	X
Test Mode	UNII-3_TX A Mode 5745 MHz

Horizontal

80 dBuV/m

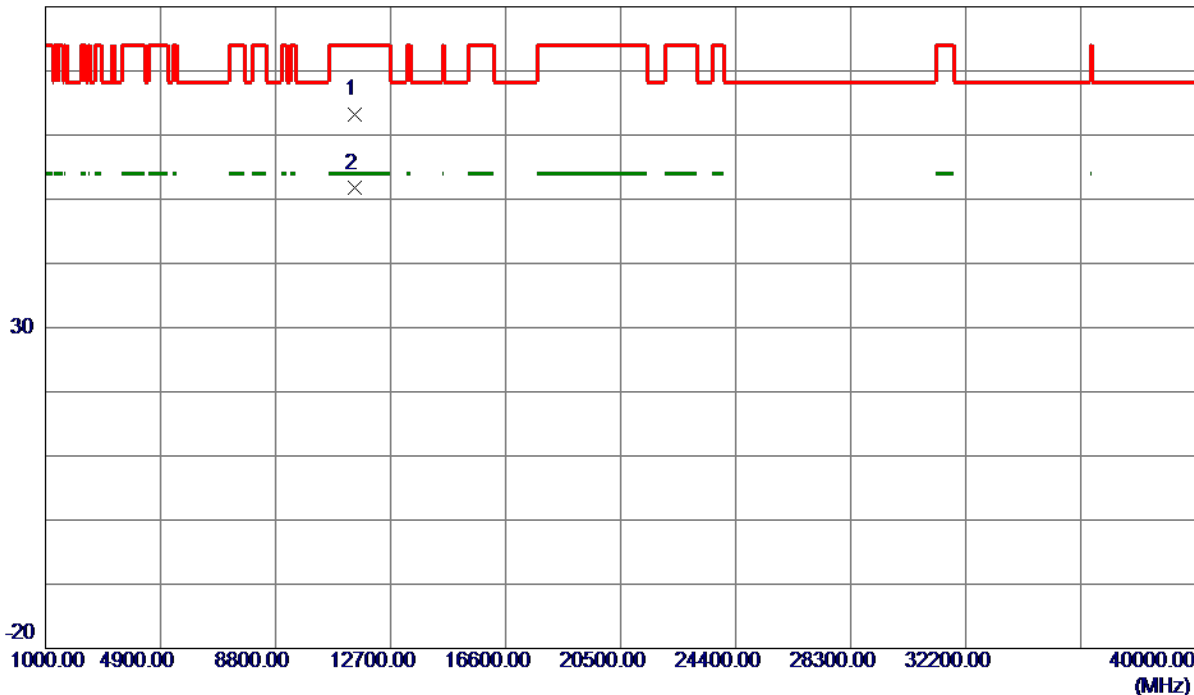

No.	Freq. MHz	Reading Level dBuV/m	Correct Factor dB	Measure ment dBuV/m	Limit dBuV/m	Margin dB	Detector	Comment
1	11493.4600	50.94	12.24	63.18	74.00	-10.82	Peak	
2 *	11493.4950	39.46	12.24	51.70	54.00	-2.30	AVG	

REMARKS:

- (1) Measurement Value = Reading Level + Correct Factor.
- (2) Margin Level = Measurement Value - Limit Value.

Orthogonal Axis	X
Test Mode	UNII-3_TX A Mode 5785 MHz

Vertical

130 dBuV/m

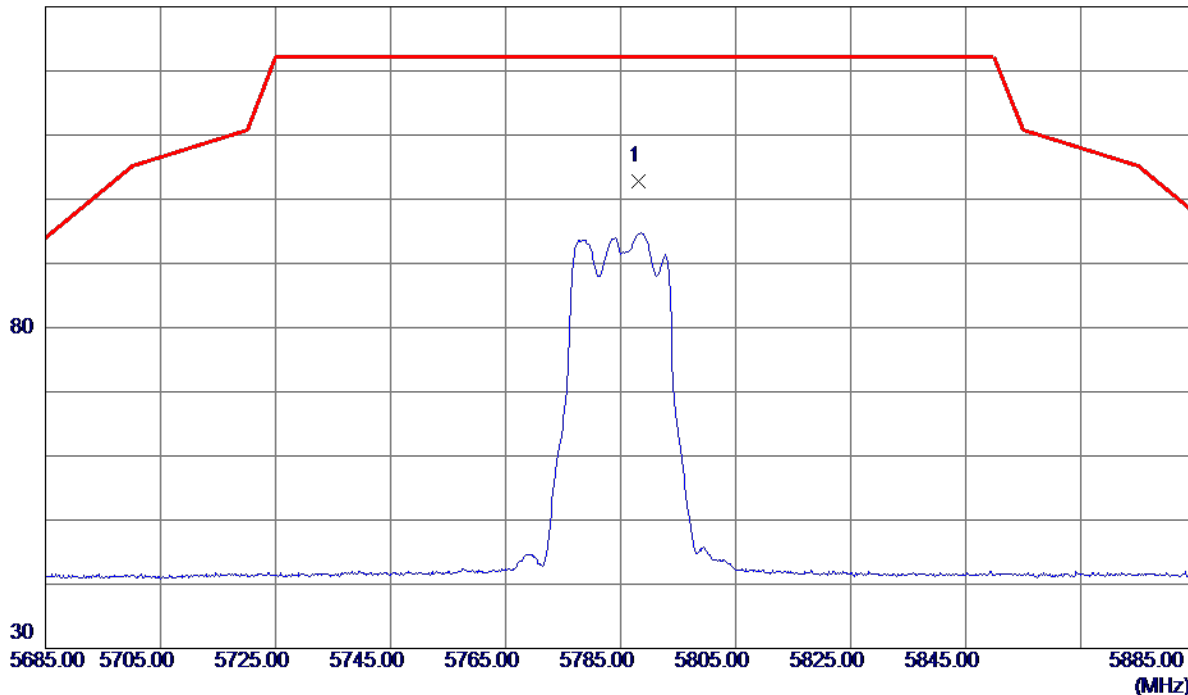

No.	Freq. MHz	Reading Level dBuV/m	Correct Factor dB	Measure ment dBuV/m	Limit dBuV/m	Margin dB	Detector	Comment
1 *	5788.1000	87.80	15.09	102.89	122.20	-19.31	Peak	No Limit

REMARKS:

- (1) Measurement Value = Reading Level + Correct Factor.
- (2) Margin Level = Measurement Value - Limit Value.

Orthogonal Axis	X
Test Mode	UNII-3_TX A Mode 5785 MHz

Vertical

80 dBuV/m

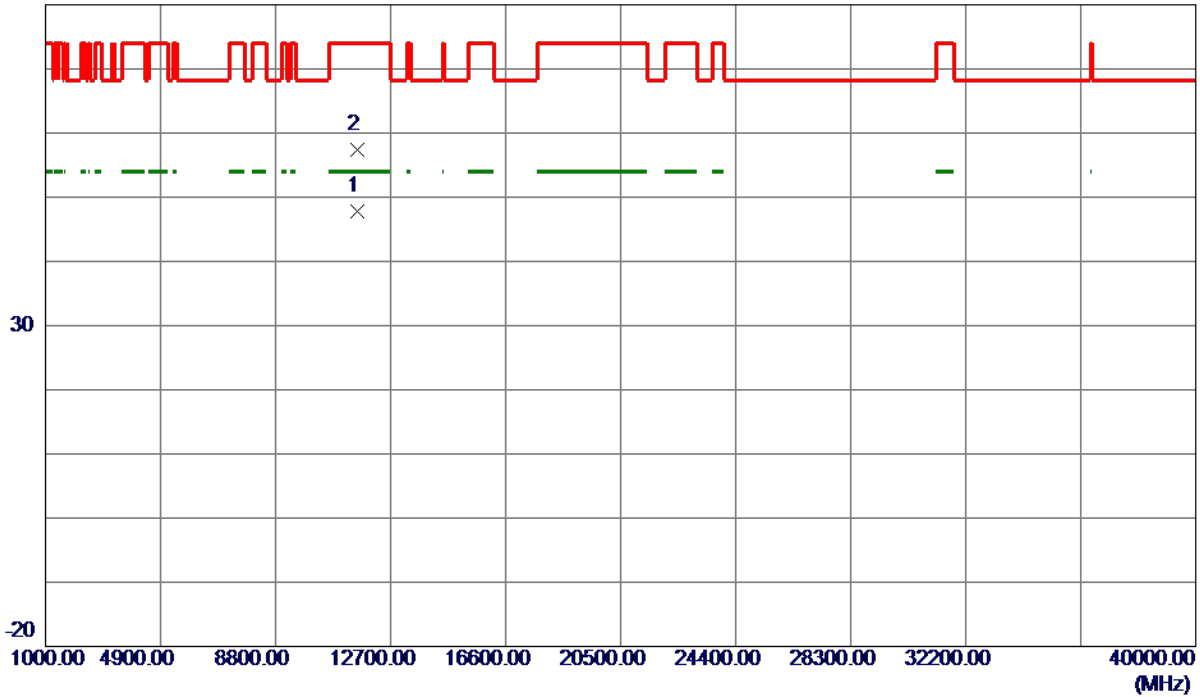

No.	Freq. MHz	Reading Level dBuV/m	Correct Factor dB	Measure ment dBuV/m	Limit dBuV/m	Margin dB	Detector	Comment
1 *	11568.5500	35.46	12.34	47.80	54.00	-6.20	AVG	
2	11573.4400	45.03	12.34	57.37	74.00	-16.63	Peak	

REMARKS:

- (1) Measurement Value = Reading Level + Correct Factor.
- (2) Margin Level = Measurement Value - Limit Value.

Orthogonal Axis	X
Test Mode	UNII-3_TX A Mode 5785 MHz

Horizontal

130 dBuV/m

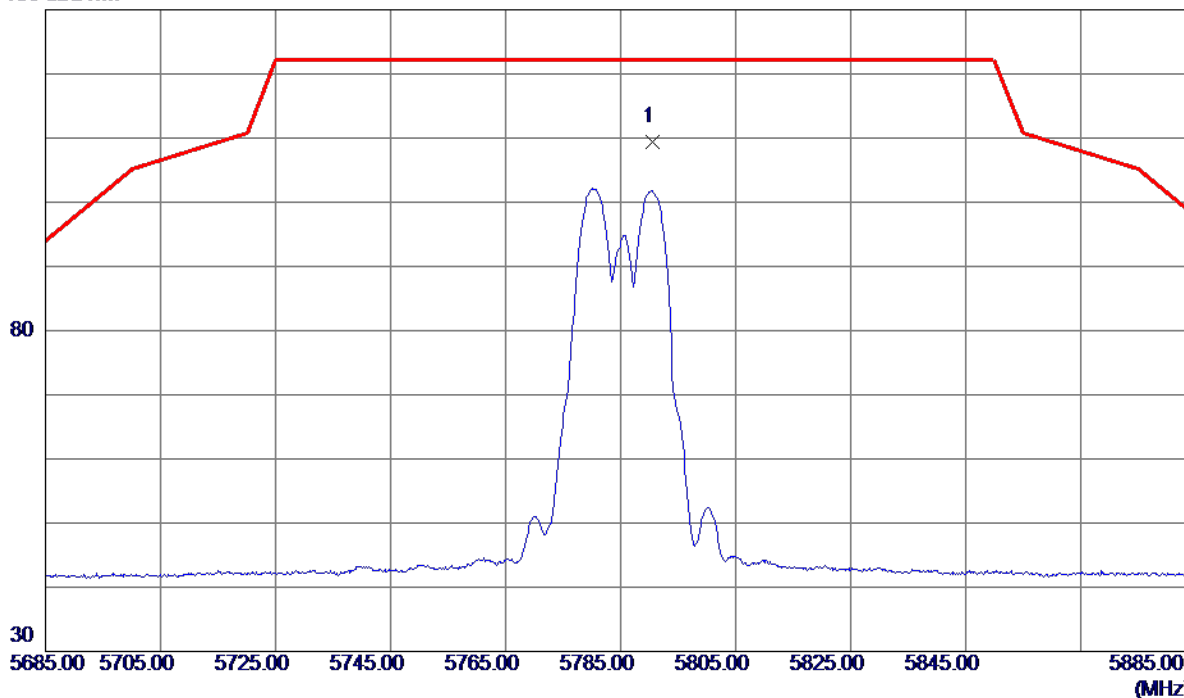

No.	Freq. MHz	Reading Level dBuV/m	Correct Factor dB	Measure ment dBuV/m	Limit dBuV/m	Margin dB	Detector	Comment
1 *	5790.5000	94.38	15.09	109.47	122.20	-12.73	Peak	No Limit

REMARKS:

- (1) Measurement Value = Reading Level + Correct Factor.
- (2) Margin Level = Measurement Value - Limit Value.

Orthogonal Axis	X
Test Mode	UNII-3_TX A Mode 5785 MHz

Horizontal

80 dBuV/m

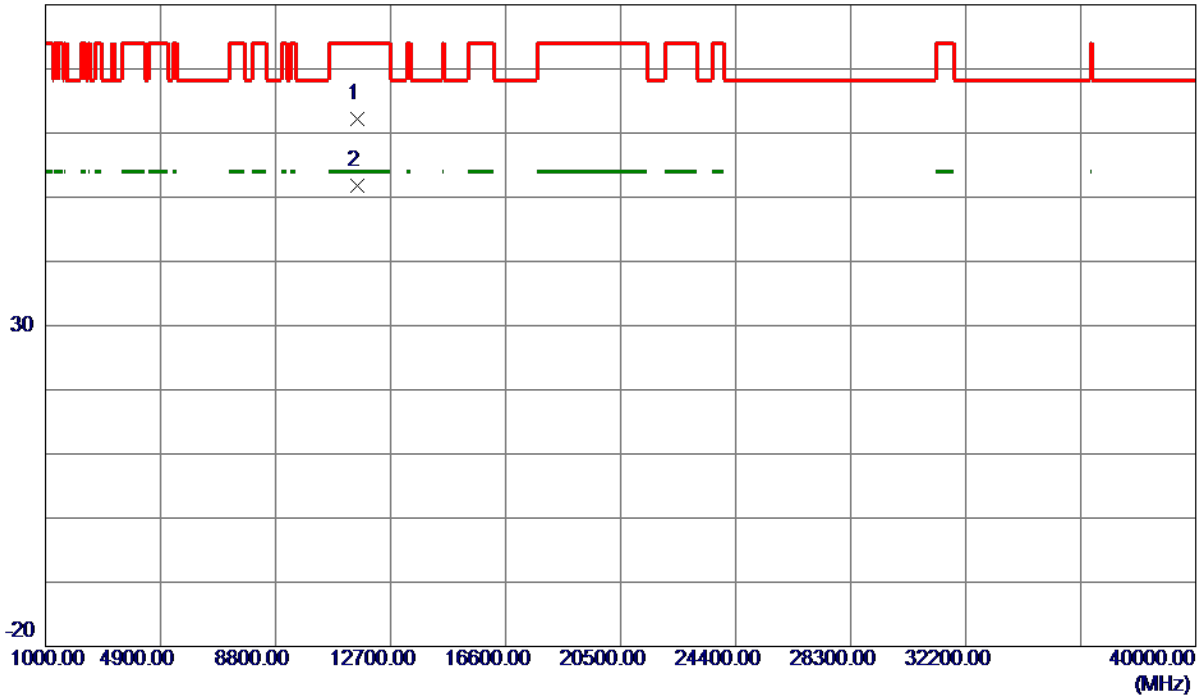

No.	Freq. MHz	Reading Level dBuV/m	Correct Factor dB	Measure ment dBuV/m	Limit dBuV/m	Margin dB	Detector	Comment
1	11573.0400	49.79	12.34	62.13	74.00	-11.87	Peak	
2 *	11573.4850	39.45	12.34	51.79	54.00	-2.21	AVG	

REMARKS:

- (1) Measurement Value = Reading Level + Correct Factor.
- (2) Margin Level = Measurement Value - Limit Value.

Orthogonal Axis	X
Test Mode	UNII-3_TX A Mode 5825 MHz

Vertical

130 dBuV/m

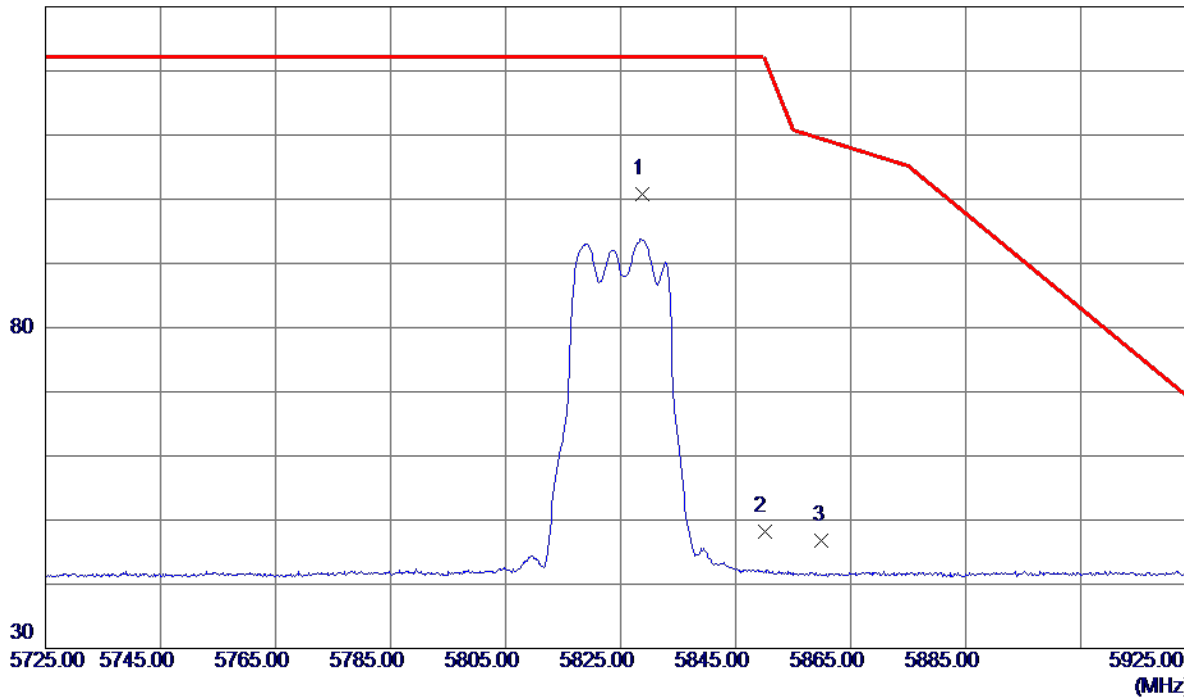

No.	Freq. MHz	Reading Level dBuV/m	Correct Factor dB	Measure ment dBuV/m	Limit dBuV/m	Margin dB	Detector	Comment
1 *	5828.7000	85.55	15.19	100.74	122.20	-21.46	Peak	No Limit
2	5850.0000	32.92	15.24	48.16	122.20	-74.04	Peak	
3	5860.0000	31.54	15.27	46.81	109.40	-62.59	Peak	

REMARKS:

- (1) Measurement Value = Reading Level + Correct Factor.
- (2) Margin Level = Measurement Value - Limit Value.

Orthogonal Axis	X
Test Mode	UNII-3_TX A Mode 5825 MHz

Vertical

80 dBuV/m

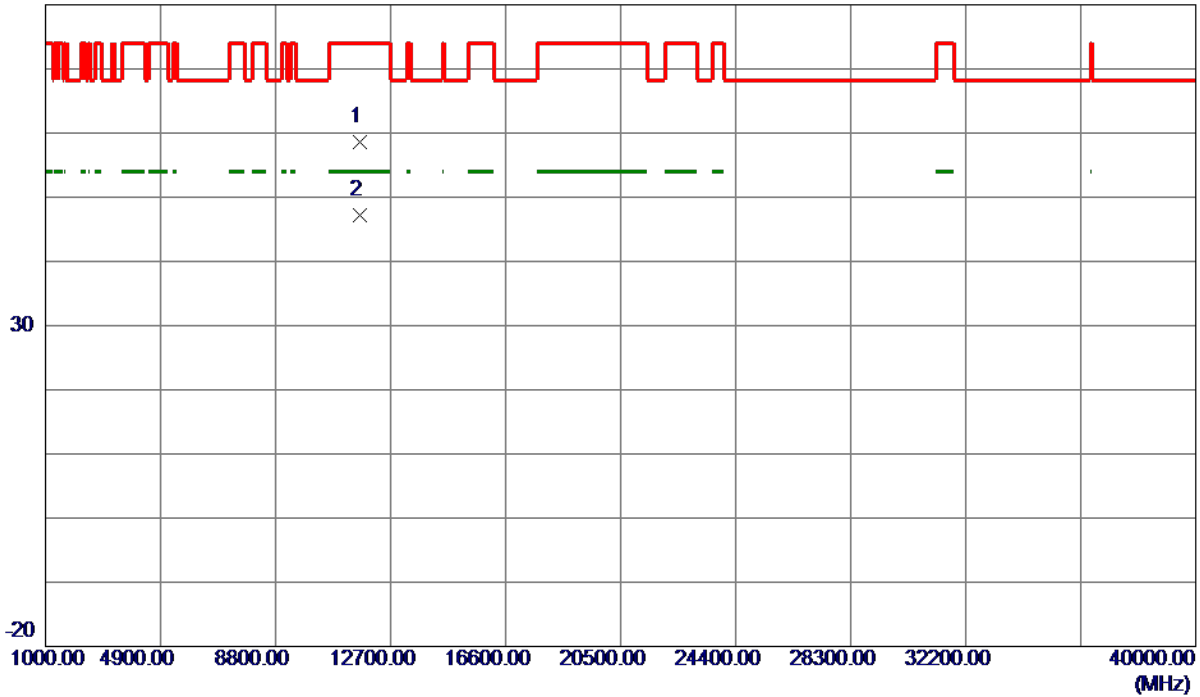

No.	Freq. MHz	Reading Level dBuV/m	Correct Factor dB	Measure ment dBuV/m	Limit dBuV/m	Margin dB	Detector	Comment
1	11648.9600	46.10	12.44	58.54	74.00	-15.46	Peak	
2 *	11649.1500	34.76	12.44	47.20	54.00	-6.80	AVG	

REMARKS:

- (1) Measurement Value = Reading Level + Correct Factor.
- (2) Margin Level = Measurement Value - Limit Value.

Orthogonal Axis	X
Test Mode	UNII-3_TX A Mode 5825 MHz

Horizontal

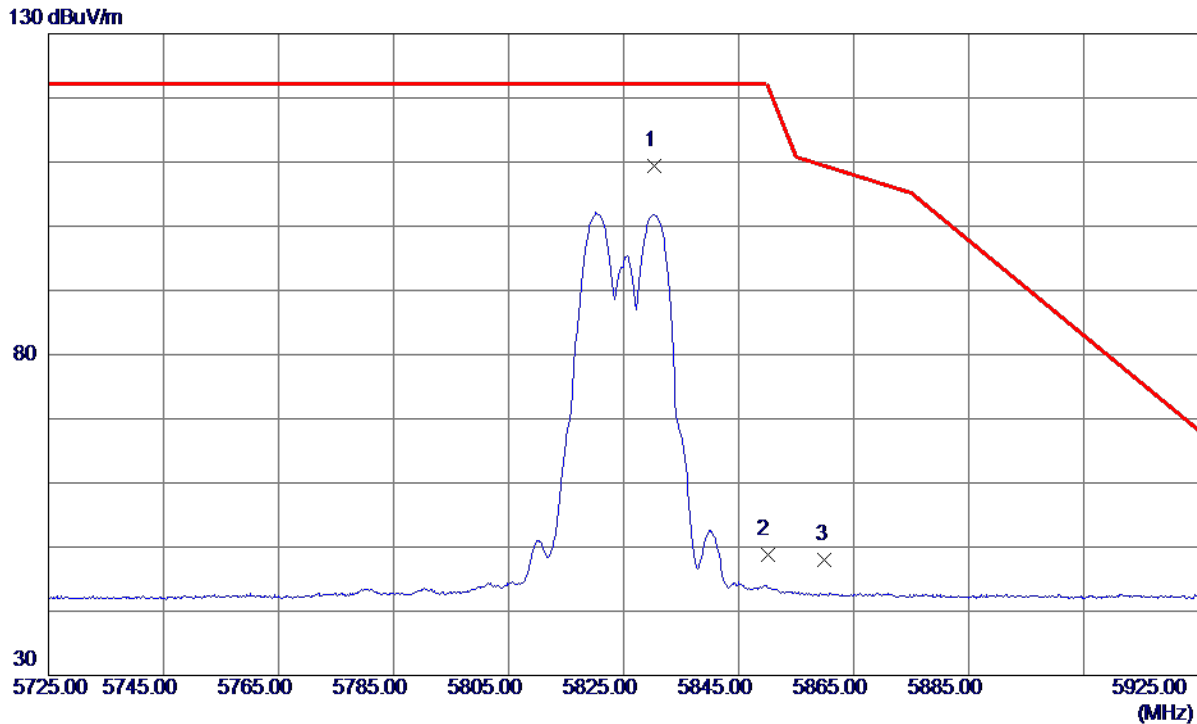

No.	Freq. MHz	Reading Level dBuV/m	Correct Factor dB	Measure ment dBuV/m	Limit dBuV/m	Margin dB	Detector	Comment
1 *	5830.3000	94.22	15.19	109.41	122.20	-12.79	Peak	No Limit
2	5850.0000	33.62	15.24	48.86	122.20	-73.34	Peak	
3	5860.0000	32.65	15.27	47.92	109.40	-61.48	Peak	

REMARKS:

- (1) Measurement Value = Reading Level + Correct Factor.
- (2) Margin Level = Measurement Value - Limit Value.

Orthogonal Axis	X
Test Mode	UNII-3_TX A Mode 5825 MHz

Horizontal

80 dBuV/m

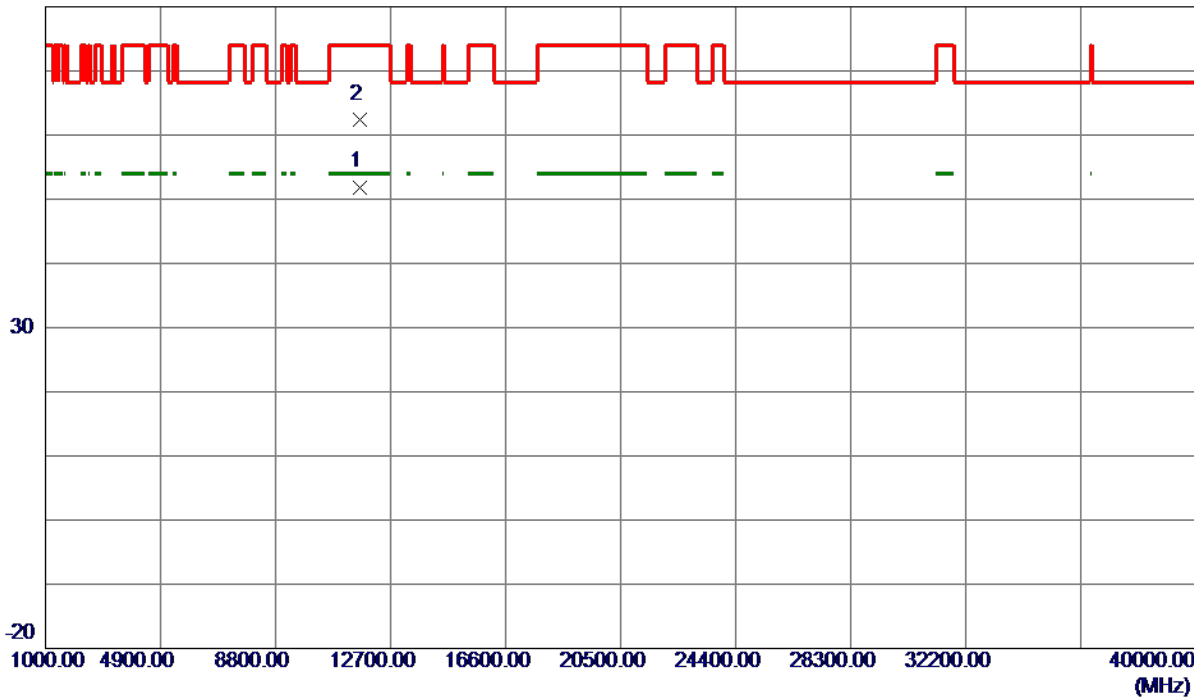

No.	Freq. MHz	Reading Level dBuV/m	Correct Factor dB	Measure ment dBuV/m	Limit dBuV/m	Margin dB	Detector	Comment
1 *	11653.5550	39.46	12.44	51.90	54.00	-2.10	AVG	
2	11653.7950	50.01	12.44	62.45	74.00	-11.55	Peak	

REMARKS:

- (1) Measurement Value = Reading Level + Correct Factor.
- (2) Margin Level = Measurement Value - Limit Value.

Orthogonal Axis	X
Test Mode	UNII-1_TX AC (VHT20) Mode 5180 MHz

Vertical

130 dBuV/m

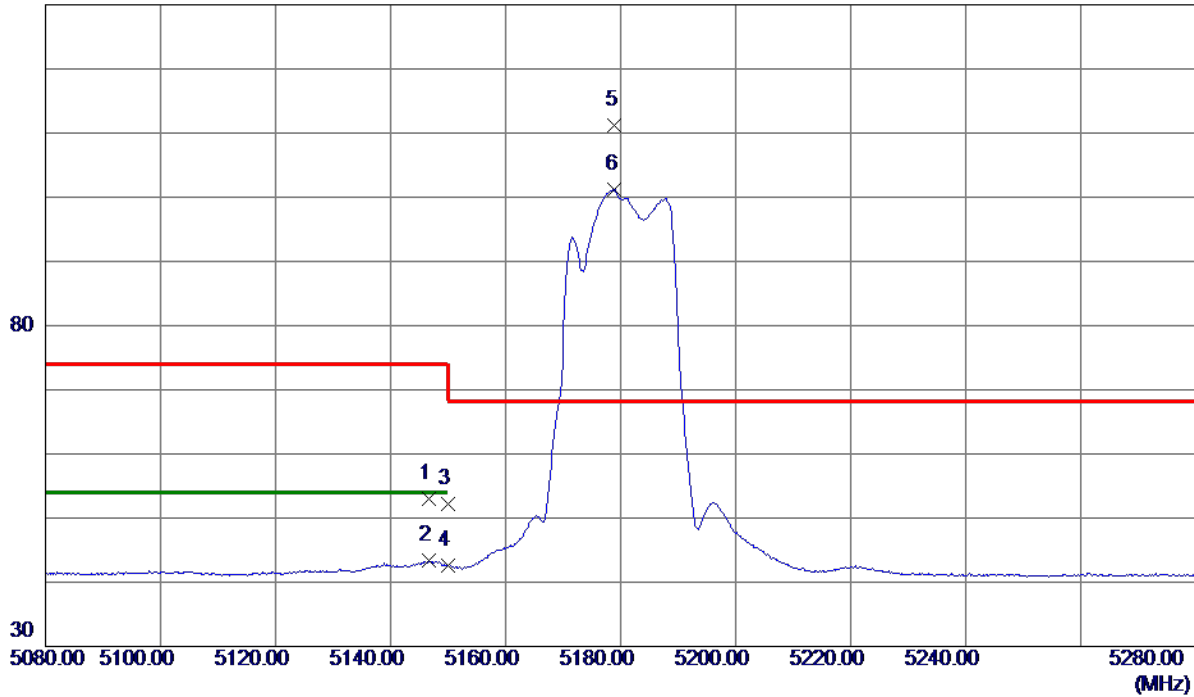

No.	Freq. MHz	Reading Level dBuV/m	Correct Factor dB	Measure ment dBuV/m	Limit dBuV/m	Margin dB	Detector	Comment
1	5146.7000	37.41	15.68	53.09	74.00	-20.91	Peak	
2	5146.7000	27.68	15.68	43.36	54.00	-10.64	AVG	
3	5150.0000	36.44	15.68	52.12	74.00	-21.88	Peak	
4	5150.0000	26.83	15.68	42.51	54.00	-11.49	AVG	
5 *	5179.0000	95.52	15.70	111.22	68.30	42.92	Peak	No Limit
6	5179.0000	85.45	15.70	101.15	999.00	-897.85	AVG	No Limit

REMARKS:

- (1) Measurement Value = Reading Level + Correct Factor.
- (2) Margin Level = Measurement Value - Limit Value.

Orthogonal Axis	X
Test Mode	UNII-1_TX AC (VHT20) Mode 5180 MHz

Vertical

80 dBuV/m

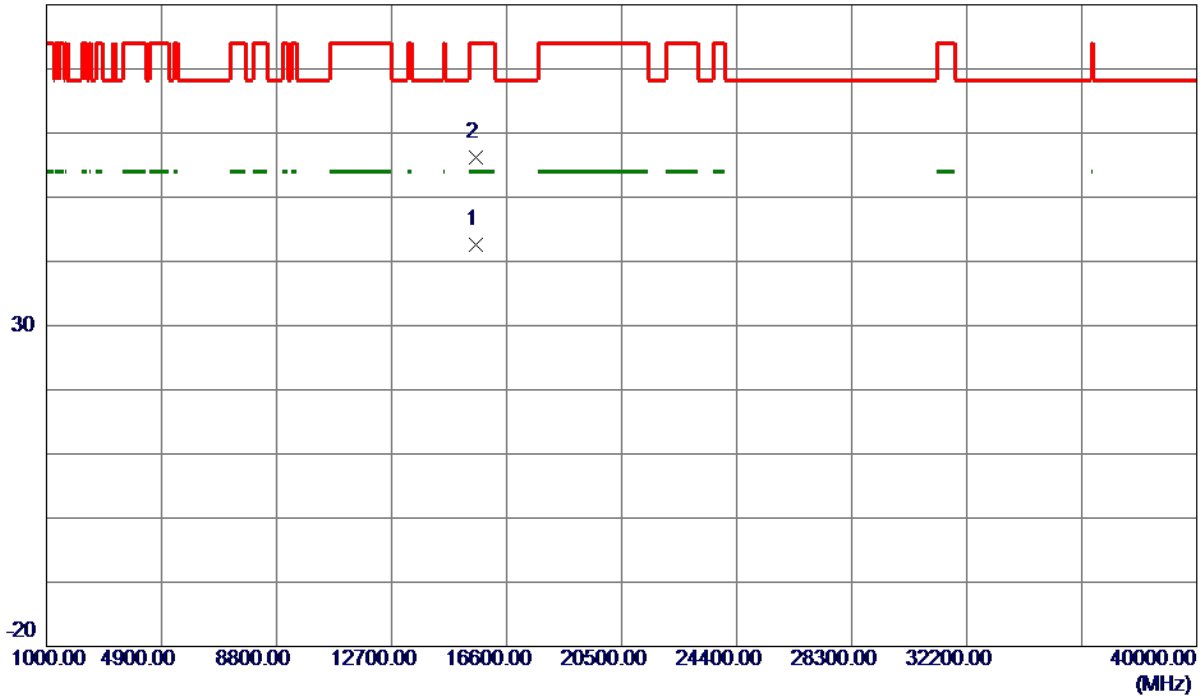

No.	Freq. MHz	Reading Level dBuV/m	Correct Factor dB	Measure ment dBuV/m	Limit dBuV/m	Margin dB	Detector	Comment
1 *	15542.9800	27.14	15.49	42.63	54.00	-11.37	AVG	
2	15544.0900	40.65	15.49	56.14	74.00	-17.86	Peak	

REMARKS:

- (1) Measurement Value = Reading Level + Correct Factor.
- (2) Margin Level = Measurement Value - Limit Value.

Orthogonal Axis	X
Test Mode	UNII-1_TX AC (VHT20) Mode 5180 MHz

Horizontal

130 dBuV/m

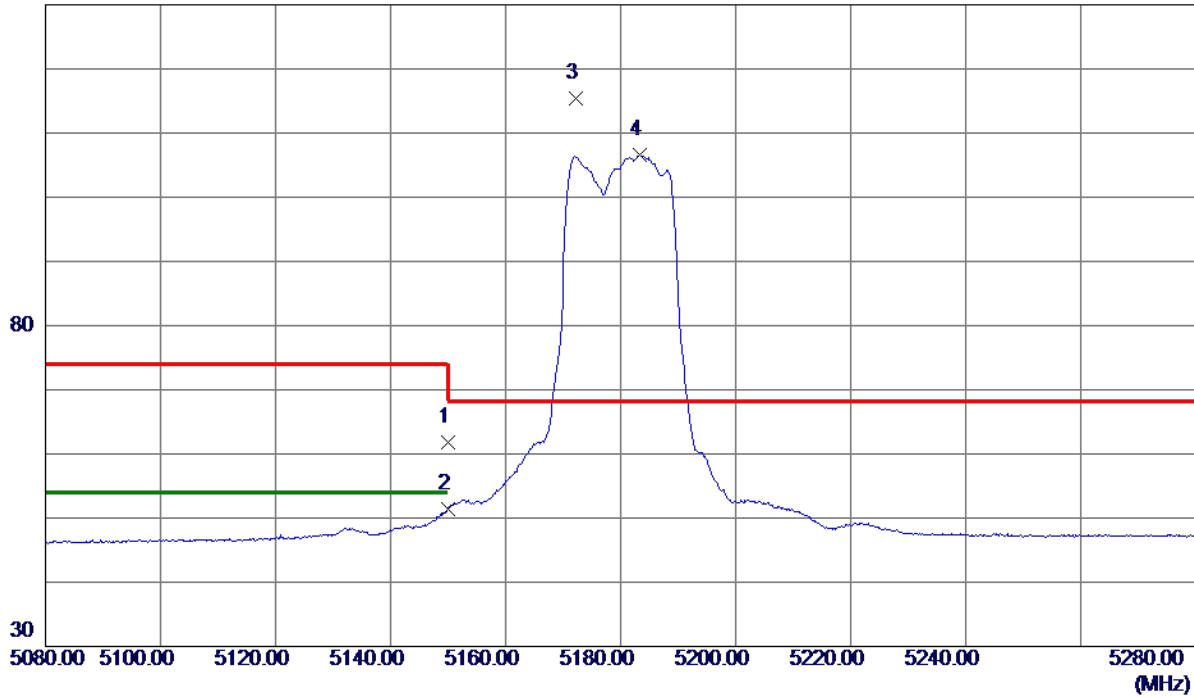

No.	Freq. MHz	Reading Level dBuV/m	Correct Factor dB	Measure ment dBuV/m	Limit dBuV/m	Margin dB	Detector	Comment
1	5150.0000	46.10	15.68	61.78	74.00	-12.22	Peak	
2	5150.0000	35.75	15.68	51.43	54.00	-2.57	AVG	
3 *	5172.3000	99.72	15.70	115.42	68.30	47.12	Peak	No Limit
4	5183.4000	90.95	15.70	106.65	999.00	-892.35	AVG	No Limit

REMARKS:

- (1) Measurement Value = Reading Level + Correct Factor.
- (2) Margin Level = Measurement Value - Limit Value.

Orthogonal Axis	X
Test Mode	UNII-1_TX AC (VHT20) Mode 5180 MHz

Horizontal

80 dBuV/m

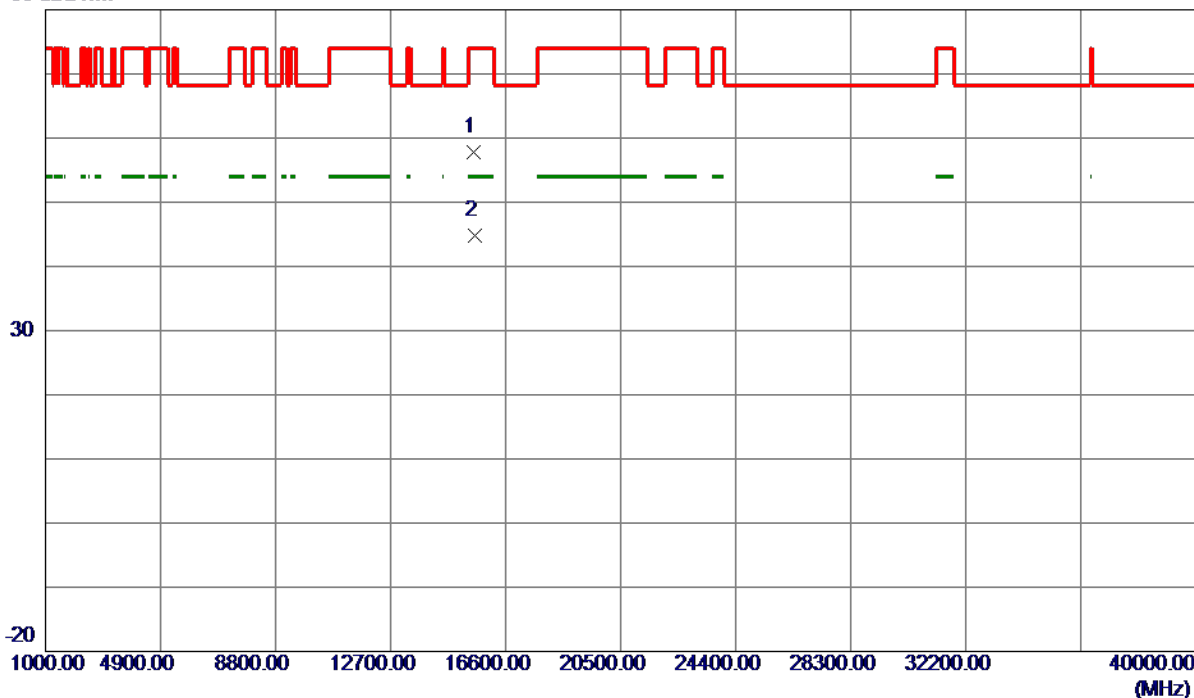

No.	Freq. MHz	Reading Level dBuV/m	Correct Factor dB	Measure ment dBuV/m	Limit dBuV/m	Margin dB	Detector	Comment
1	15535.8500	42.36	15.50	57.86	74.00	-16.14	Peak	
2 *	15539.4000	29.22	15.49	44.71	54.00	-9.29	AVG	

REMARKS:

- (1) Measurement Value = Reading Level + Correct Factor.
- (2) Margin Level = Measurement Value - Limit Value.

Orthogonal Axis	X
Test Mode	UNII-1_TX AC (VHT20) Mode 5200 MHz

Vertical

130 dBuV/m

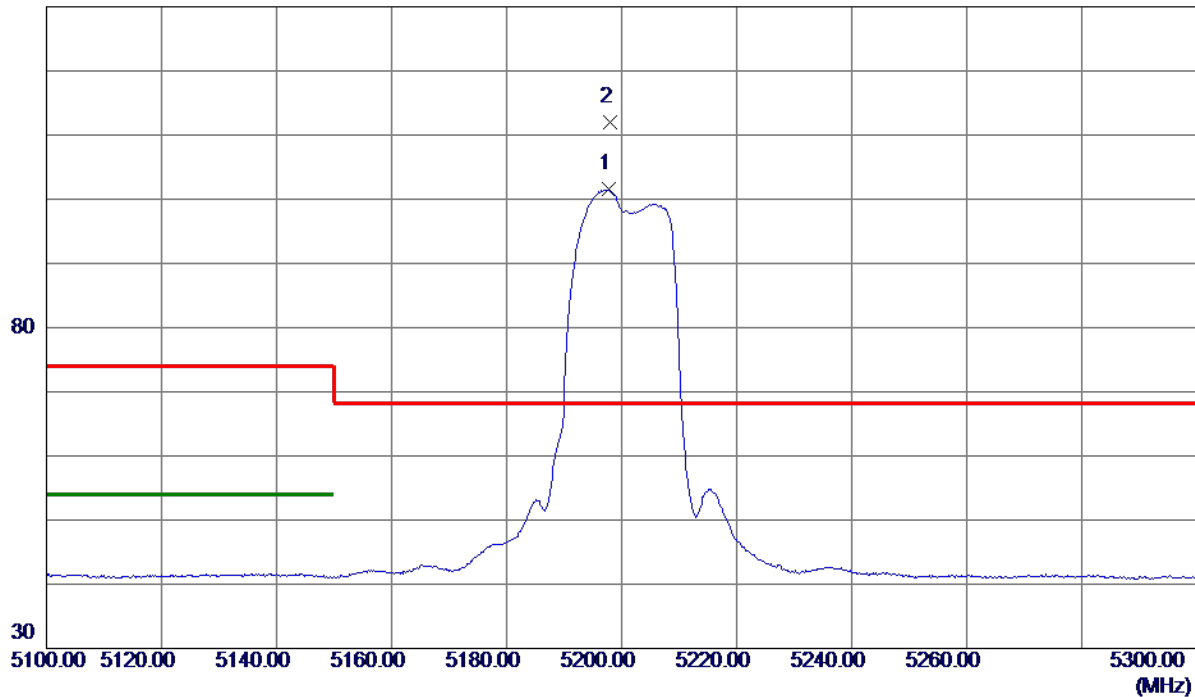

No.	Freq. MHz	Reading Level dBuV/m	Correct Factor dB	Measure ment dBuV/m	Limit dBuV/m	Margin dB	Detector	Comment
1	5197.7000	85.85	15.71	101.56	999.00	-897.44	AVG	No Limit
2 *	5198.0000	96.21	15.71	111.92	68.30	43.62	Peak	No Limit

REMARKS:

- (1) Measurement Value = Reading Level + Correct Factor.
- (2) Margin Level = Measurement Value - Limit Value.

Orthogonal Axis	X
Test Mode	UNII-1_TX AC (VHT20) Mode 5200 MHz

Vertical

80 dBuV/m

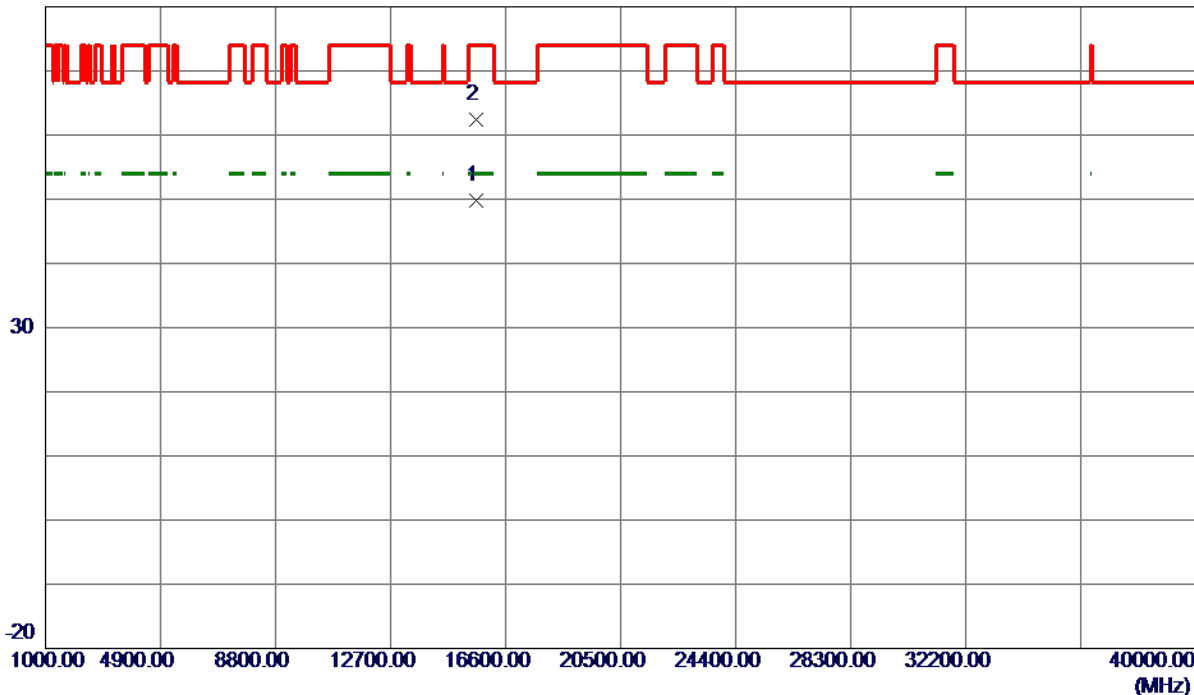

No.	Freq. MHz	Reading Level dBuV/m	Correct Factor dB	Measure ment dBuV/m	Limit dBuV/m	Margin dB	Detector	Comment
1 *	15600.4300	34.25	15.47	49.72	54.00	-4.28	AVG	
2	15609.1400	46.87	15.47	62.34	74.00	-11.66	Peak	

REMARKS:

- (1) Measurement Value = Reading Level + Correct Factor.
- (2) Margin Level = Measurement Value - Limit Value.

Orthogonal Axis	X
Test Mode	UNII-1_TX AC (VHT20) Mode 5200 MHz

Horizontal

130 dBuV/m

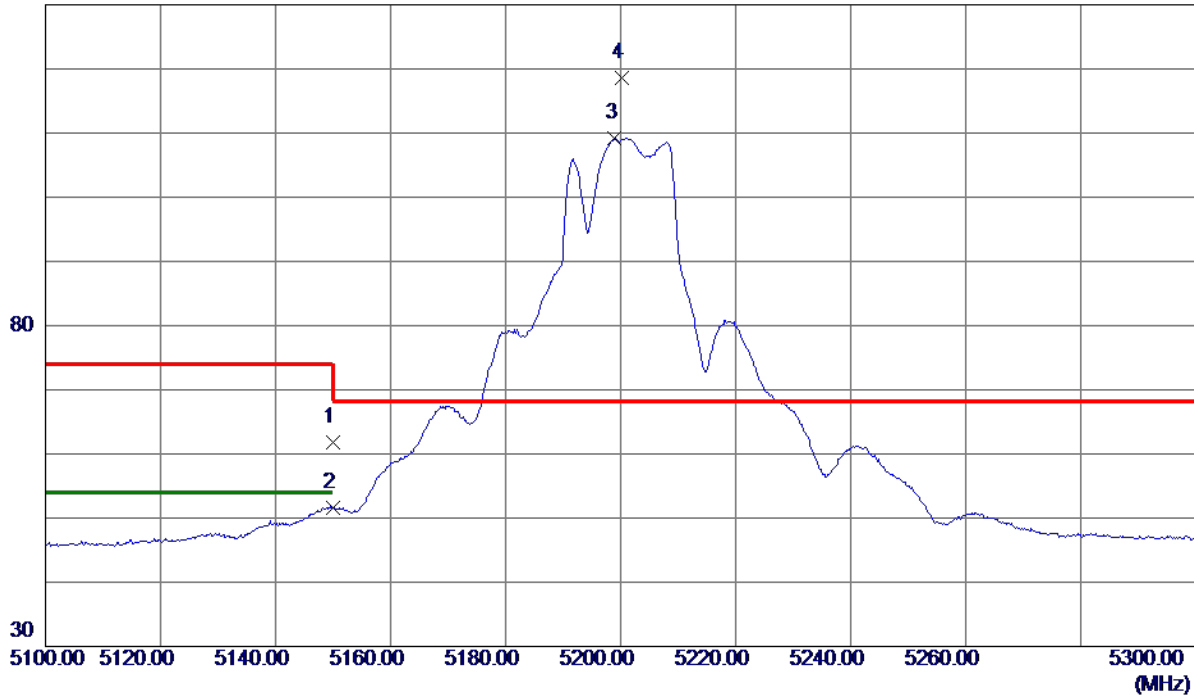

No.	Freq. MHz	Reading Level dBuV/m	Correct Factor dB	Measure ment dBuV/m	Limit dBuV/m	Margin dB	Detector	Comment
1	5150.0000	46.13	15.68	61.81	74.00	-12.19	Peak	
2	5150.0000	35.91	15.68	51.59	54.00	-2.41	AVG	
3	5199.0000	93.48	15.71	109.19	999.00	-889.81	AVG	No Limit
4 *	5200.2000	102.81	15.71	118.52	68.30	50.22	Peak	No Limit

REMARKS:

- (1) Measurement Value = Reading Level + Correct Factor.
- (2) Margin Level = Measurement Value - Limit Value.

Orthogonal Axis	X
Test Mode	UNII-1_TX AC (VHT20) Mode 5200 MHz

Horizontal

80 dBuV/m



No.	Freq. MHz	Reading Level dBuV/m	Correct Factor dB	Measure ment dBuV/m	Limit dBuV/m	Margin dB	Detector	Comment
1 *	15593.6000	36.06	15.47	51.53	54.00	-2.47	AVG	
2	15594.7500	48.64	15.47	64.11	74.00	-9.89	Peak	

REMARKS:

- (1) Measurement Value = Reading Level + Correct Factor.
- (2) Margin Level = Measurement Value - Limit Value.

Orthogonal Axis	X
Test Mode	UNII-1_TX AC (VHT20) Mode 5240 MHz

Vertical

130 dBuV/m

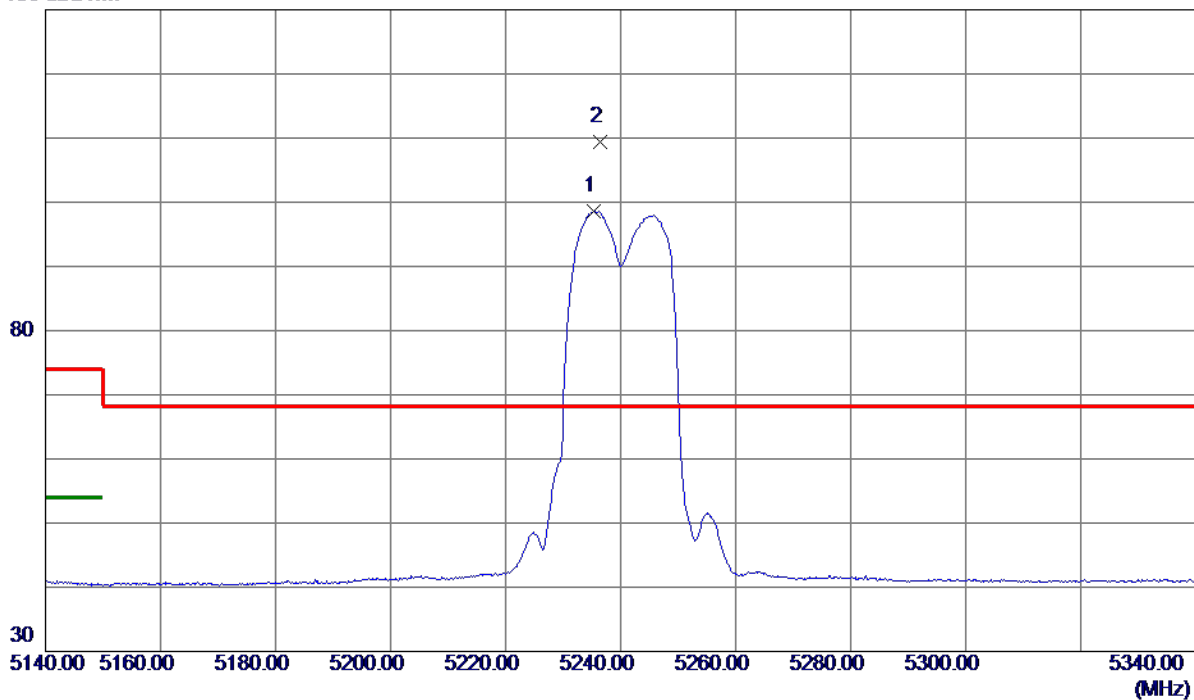

No.	Freq. MHz	Reading Level dBuV/m	Correct Factor dB	Measure ment dBuV/m	Limit dBuV/m	Margin dB	Detector	Comment
1	5235.4000	82.85	15.73	98.58	999.00	-900.42	AVG	No Limit
2 *	5236.4000	93.63	15.73	109.36	68.30	41.06	Peak	No Limit

REMARKS:

- (1) Measurement Value = Reading Level + Correct Factor.
- (2) Margin Level = Measurement Value - Limit Value.

Orthogonal Axis	X
Test Mode	UNII-1_TX AC (VHT20) Mode 5240 MHz

Vertical

80 dBuV/m

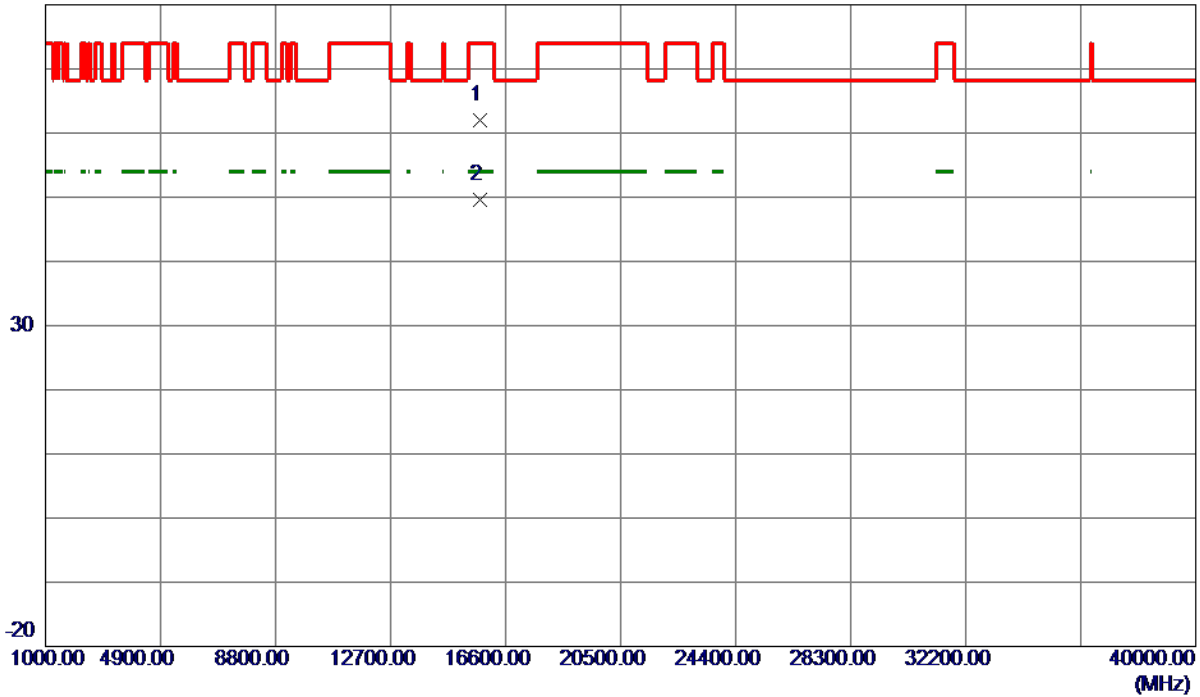

No.	Freq. MHz	Reading Level dBuV/m	Correct Factor dB	Measure ment dBuV/m	Limit dBuV/m	Margin dB	Detector	Comment
1	15720.2100	46.50	15.42	61.92	74.00	-12.08	Peak	
2 *	15728.7300	34.12	15.42	49.54	54.00	-4.46	AVG	

REMARKS:

- (1) Measurement Value = Reading Level + Correct Factor.
- (2) Margin Level = Measurement Value - Limit Value.

Orthogonal Axis	X
Test Mode	UNII-1_TX AC (VHT20) Mode 5240 MHz

Horizontal

130 dBuV/m

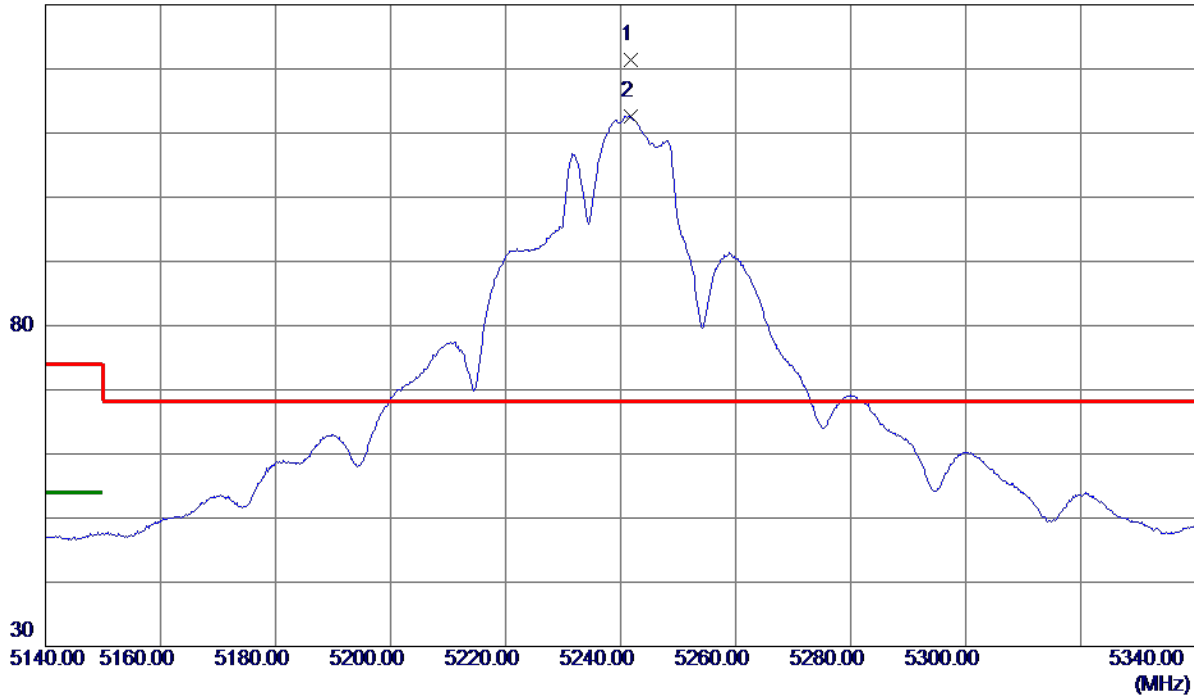

No.	Freq. MHz	Reading Level dBuV/m	Correct Factor dB	Measure ment dBuV/m	Limit dBuV/m	Margin dB	Detector	Comment
1 *	5241.7000	105.69	15.73	121.42	68.30	53.12	Peak	No Limit
2	5241.7000	96.84	15.73	112.57	999.00	-886.43	AVG	No Limit

REMARKS:

- (1) Measurement Value = Reading Level + Correct Factor.
- (2) Margin Level = Measurement Value - Limit Value.

Orthogonal Axis	X
Test Mode	UNII-1_TX AC (VHT20) Mode 5240 MHz

Horizontal

80 dBuV/m

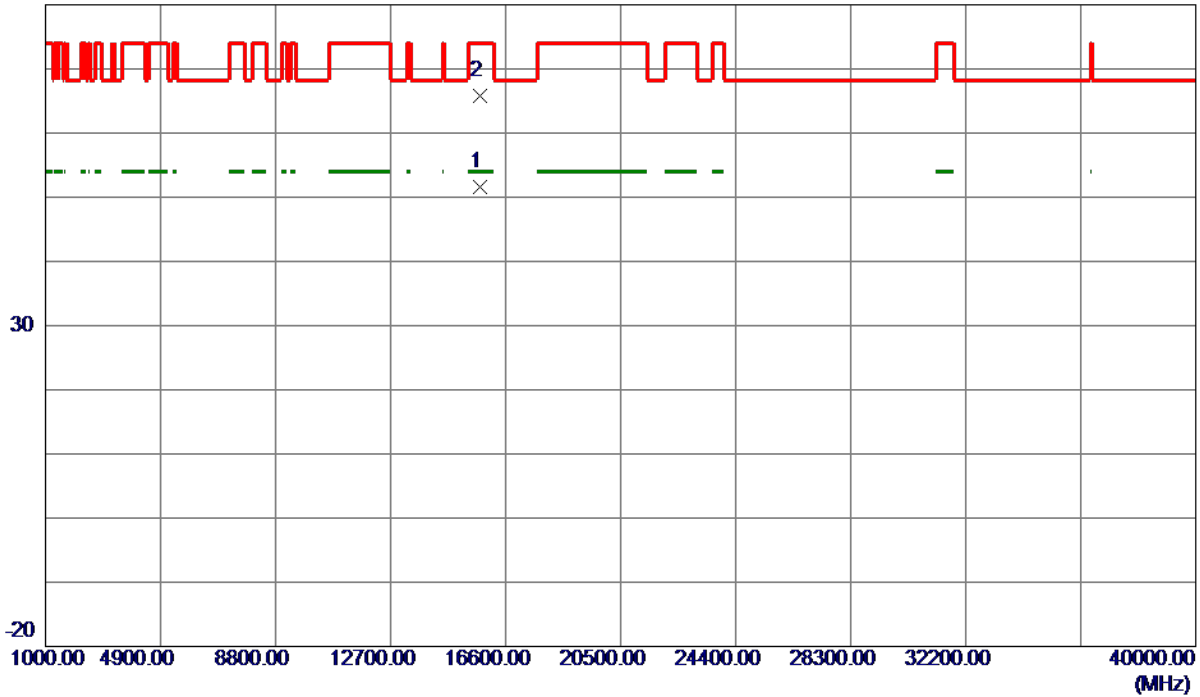

No.	Freq. MHz	Reading Level dBuV/m	Correct Factor dB	Measure ment dBuV/m	Limit dBuV/m	Margin dB	Detector	Comment
1 *	15724.2000	36.14	15.42	51.56	54.00	-2.44	AVG	
2	15724.3000	50.28	15.42	65.70	74.00	-8.30	Peak	

REMARKS:

- (1) Measurement Value = Reading Level + Correct Factor.
- (2) Margin Level = Measurement Value - Limit Value.

Orthogonal Axis	X
Test Mode	UNII-1_TX AC (VHT40) Mode 5190 MHz

Vertical

130 dBuV/m

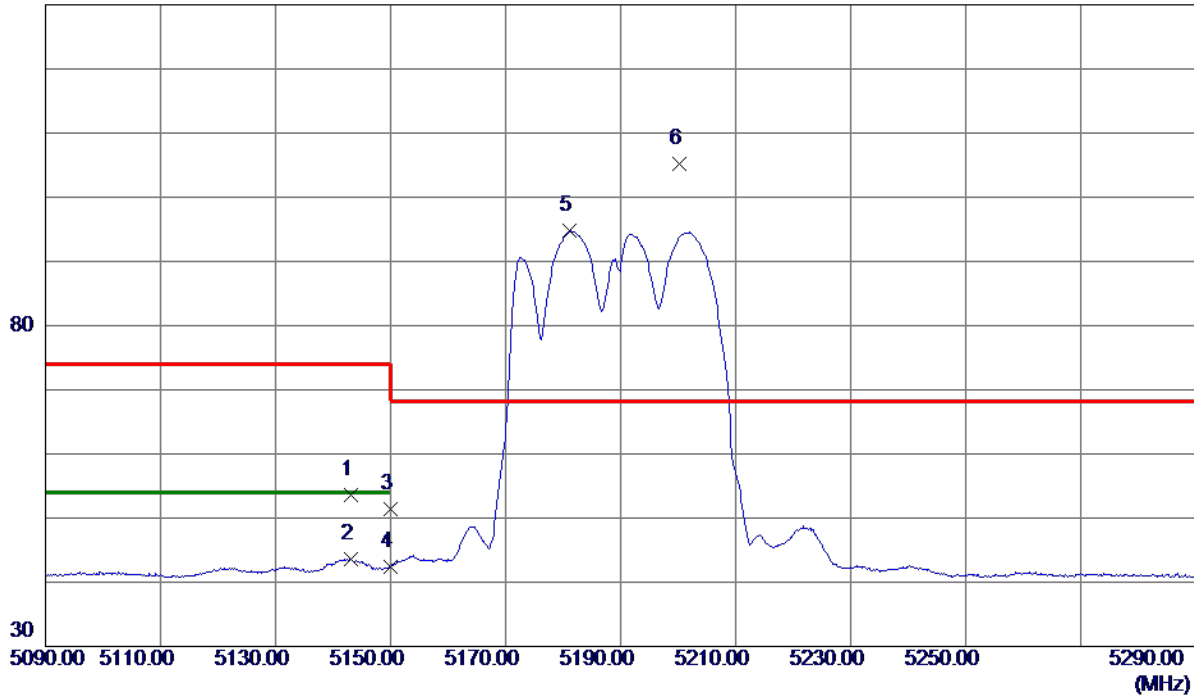

No.	Freq. MHz	Reading Level dBuV/m	Correct Factor dB	Measure ment dBuV/m	Limit dBuV/m	Margin dB	Detector	Comment
1	5143.1000	37.86	15.68	53.54	74.00	-20.46	Peak	
2	5143.1000	27.95	15.68	43.63	54.00	-10.37	AVG	
3	5150.0000	35.74	15.68	51.42	74.00	-22.58	Peak	
4	5150.0000	26.81	15.68	42.49	54.00	-11.51	AVG	
5	5181.2000	79.02	15.70	94.72	999.00	-904.28	AVG	No Limit
6 *	5200.3000	89.41	15.71	105.12	68.30	36.82	Peak	No Limit

REMARKS:

- (1) Measurement Value = Reading Level + Correct Factor.
- (2) Margin Level = Measurement Value - Limit Value.

Orthogonal Axis	X
Test Mode	UNII-1_TX AC (VHT40) Mode 5190 MHz

Vertical

80 dBuV/m

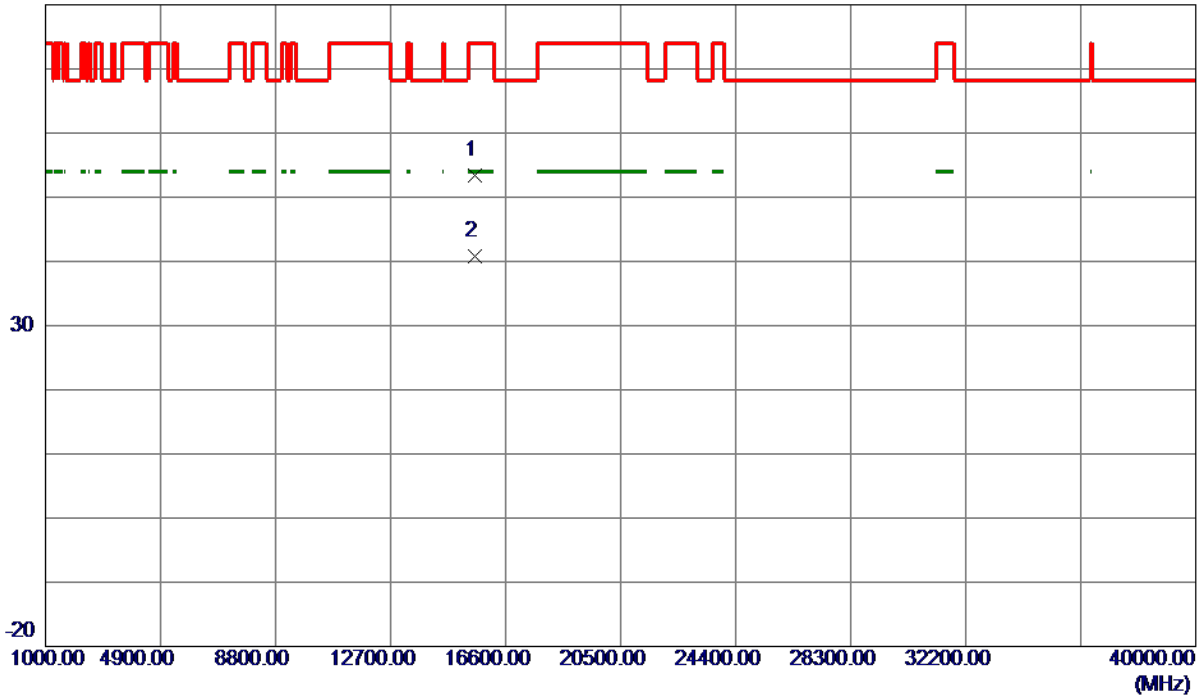

No.	Freq. MHz	Reading Level dBuV/m	Correct Factor dB	Measure ment dBuV/m	Limit dBuV/m	Margin dB	Detector	Comment
1	15565.3200	37.95	15.48	53.43	74.00	-20.57	Peak	
2 *	15576.9600	25.35	15.48	40.83	54.00	-13.17	AVG	

REMARKS:

- (1) Measurement Value = Reading Level + Correct Factor.
- (2) Margin Level = Measurement Value - Limit Value.

Orthogonal Axis	X
Test Mode	UNII-1_TX AC (VHT40) Mode 5190 MHz

Horizontal

130 dBuV/m

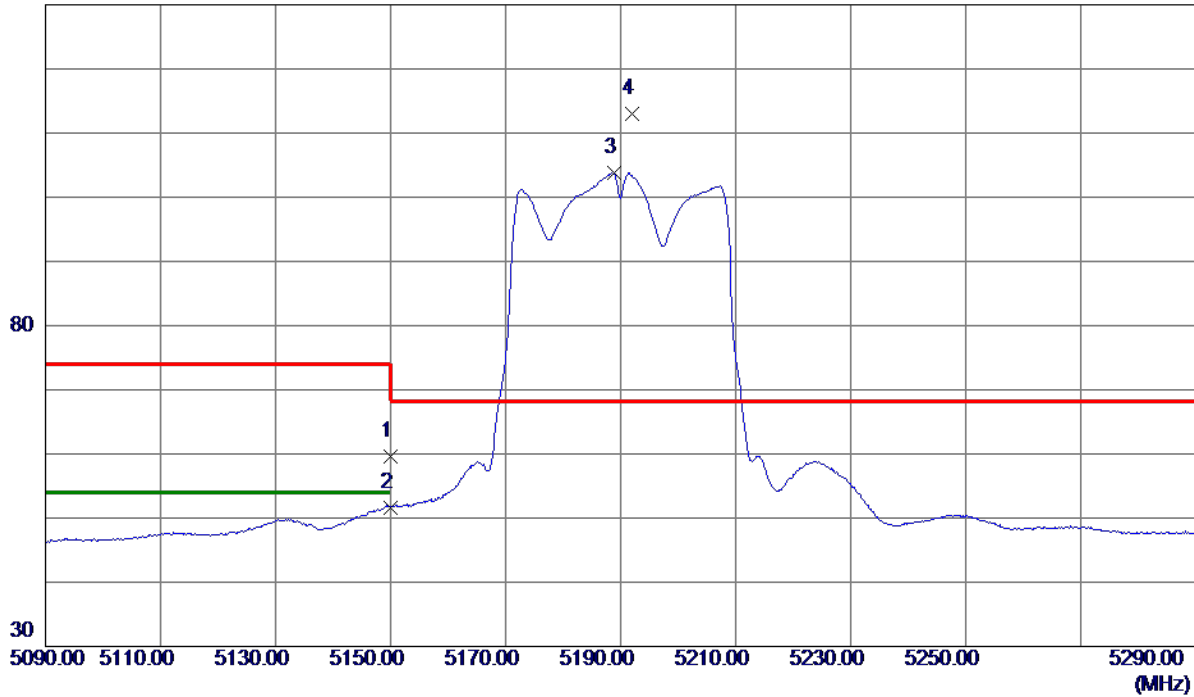

No.	Freq. MHz	Reading Level dBuV/m	Correct Factor dB	Measure ment dBuV/m	Limit dBuV/m	Margin dB	Detector	Comment
1	5150.0000	43.93	15.68	59.61	74.00	-14.39	Peak	
2	5150.0000	35.99	15.68	51.67	54.00	-2.33	AVG	
3	5188.8000	88.12	15.70	103.82	999.00	-895.18	AVG	No Limit
4 *	5192.0000	97.21	15.71	112.92	68.30	44.62	Peak	No Limit

REMARKS:

- (1) Measurement Value = Reading Level + Correct Factor.
- (2) Margin Level = Measurement Value - Limit Value.

Orthogonal Axis	X
Test Mode	UNII-1_TX AC (VHT40) Mode 5190 MHz

Horizontal

80 dBuV/m

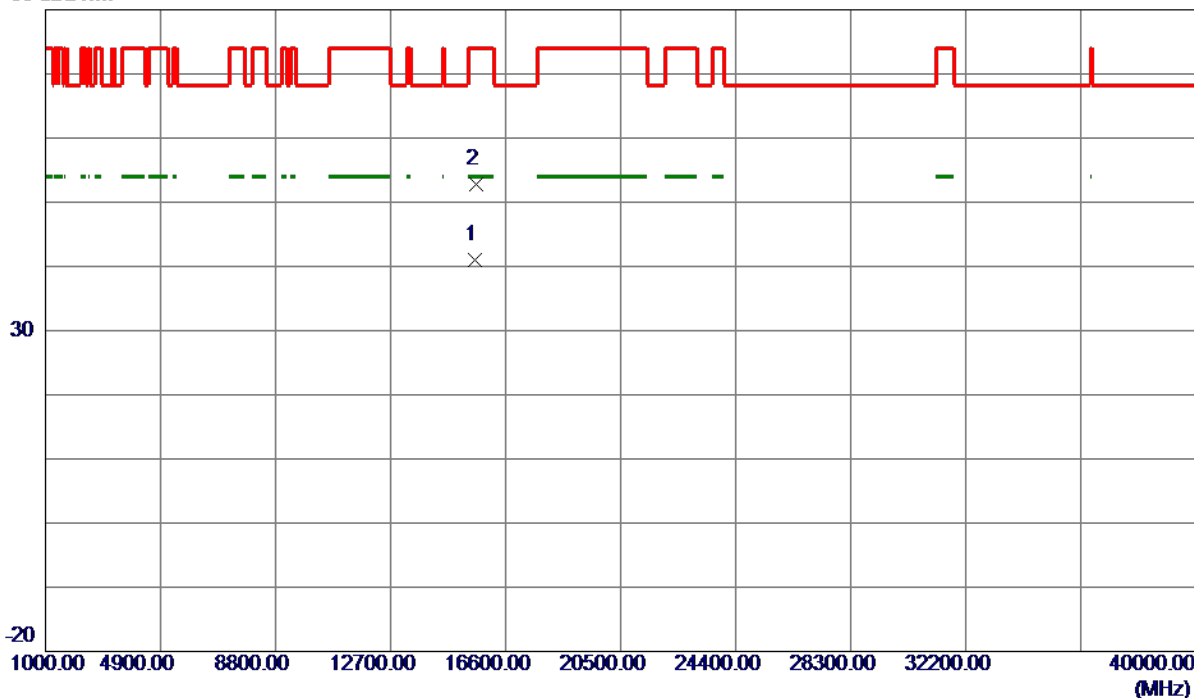

No.	Freq. MHz	Reading Level dBuV/m	Correct Factor dB	Measure ment dBuV/m	Limit dBuV/m	Margin dB	Detector	Comment
1 *	15561.8000	25.50	15.49	40.99	54.00	-13.01	AVG	
2	15604.9500	37.25	15.47	52.72	74.00	-21.28	Peak	

REMARKS:

- (1) Measurement Value = Reading Level + Correct Factor.
- (2) Margin Level = Measurement Value - Limit Value.

Orthogonal Axis	X
Test Mode	UNII-1_TX AC (VHT40) Mode 5230 MHz

Vertical

130 dBuV/m



No.	Freq. MHz	Reading Level dBuV/m	Correct Factor dB	Measure ment dBuV/m	Limit dBuV/m	Margin dB	Detector	Comment
1 *	5237.4000	87.93	15.73	103.66	68.30	35.36	Peak	No Limit
2	5238.9000	78.90	15.73	94.63	999.00	-904.37	AVG	No Limit

REMARKS:

- (1) Measurement Value = Reading Level + Correct Factor.
- (2) Margin Level = Measurement Value - Limit Value.

Orthogonal Axis	X
Test Mode	UNII-1_TX AC (VHT40) Mode 5230 MHz

Vertical

80 dBuV/m

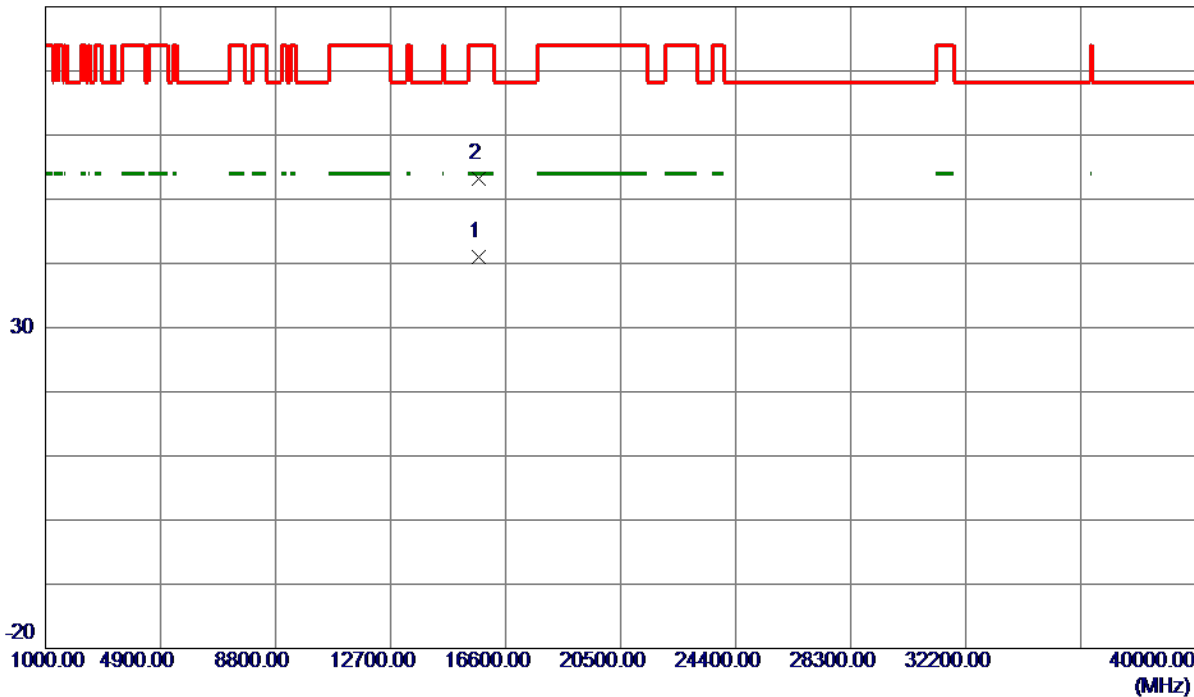

No.	Freq. MHz	Reading Level dBuV/m	Correct Factor dB	Measurement dBuV/m	Limit dBuV/m	Margin dB	Detector	Comment
1 *	15688.9200	25.51	15.43	40.94	54.00	-13.06	AVG	
2	15696.8300	37.84	15.43	53.27	74.00	-20.73	Peak	

REMARKS:

- (1) Measurement Value = Reading Level + Correct Factor.
- (2) Margin Level = Measurement Value - Limit Value.

Orthogonal Axis	X
Test Mode	UNII-1_TX AC (VHT40) Mode 5230 MHz

Horizontal

130 dBuV/m

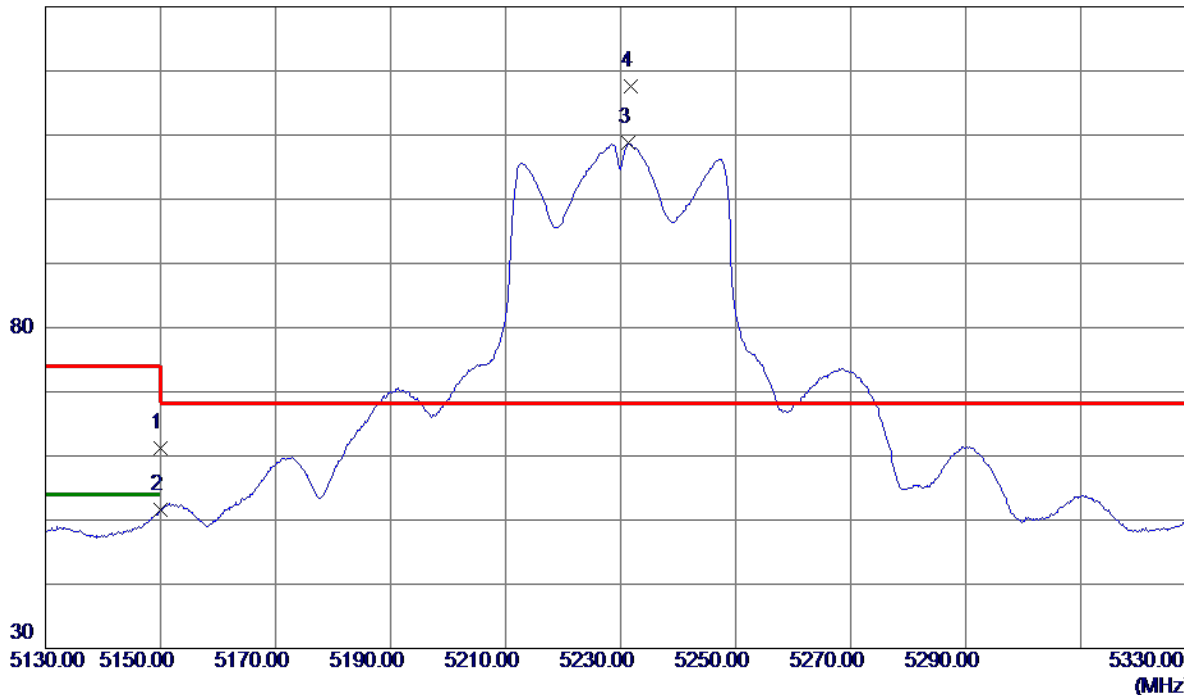

No.	Freq. MHz	Reading Level dBuV/m	Correct Factor dB	Measure ment dBuV/m	Limit dBuV/m	Margin dB	Detector	Comment
1	5150.0000	45.59	15.68	61.27	74.00	-12.73	Peak	
2	5150.0000	35.92	15.68	51.60	54.00	-2.40	AVG	
3	5231.3000	93.01	15.73	108.74	999.00	-890.26	AVG	No Limit
4 *	5231.7000	101.81	15.73	117.54	68.30	49.24	Peak	No Limit

REMARKS:

- (1) Measurement Value = Reading Level + Correct Factor.
- (2) Margin Level = Measurement Value - Limit Value.

Orthogonal Axis	X
Test Mode	UNII-1_TX AC (VHT40) Mode 5230 MHz

Horizontal

80 dBuV/m

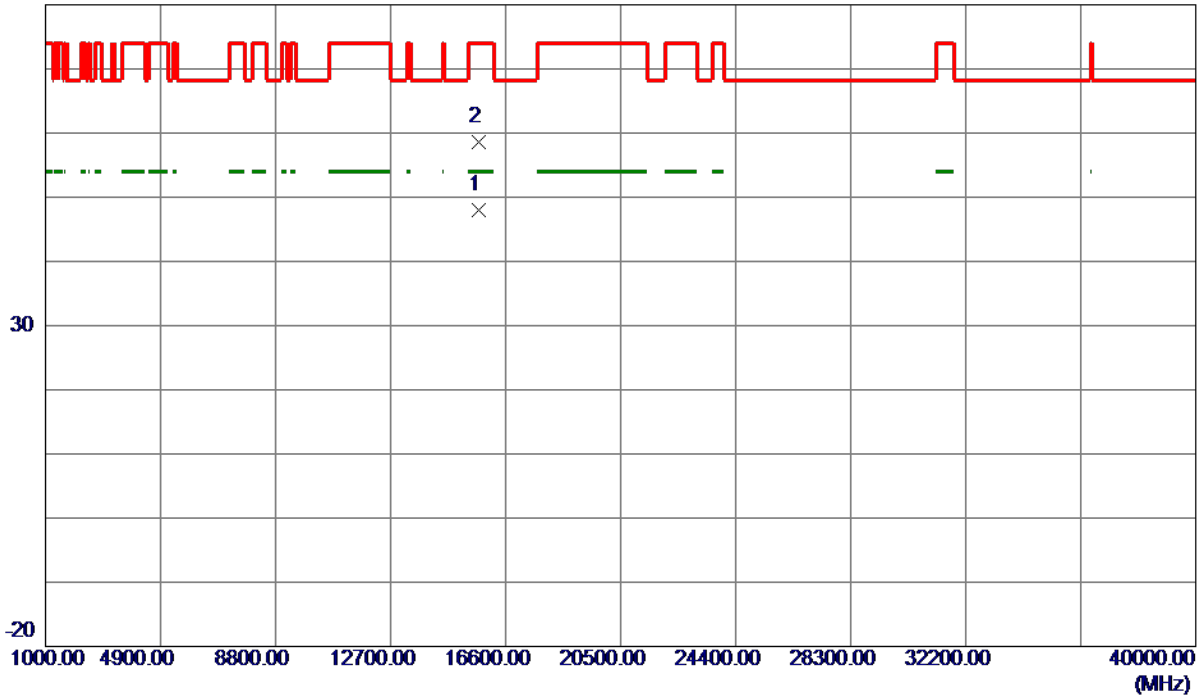

No.	Freq. MHz	Reading Level dBuV/m	Correct Factor dB	Measure ment dBuV/m	Limit dBuV/m	Margin dB	Detector	Comment
1 *	15685.3000	32.63	15.44	48.07	54.00	-5.93	AVG	
2	15704.8000	43.25	15.43	58.68	74.00	-15.32	Peak	

REMARKS:

- (1) Measurement Value = Reading Level + Correct Factor.
- (2) Margin Level = Measurement Value - Limit Value.

Orthogonal Axis	X
Test Mode	UNII-1_TX AC (VHT80) Mode 5210 MHz

Vertical

130 dBuV/m

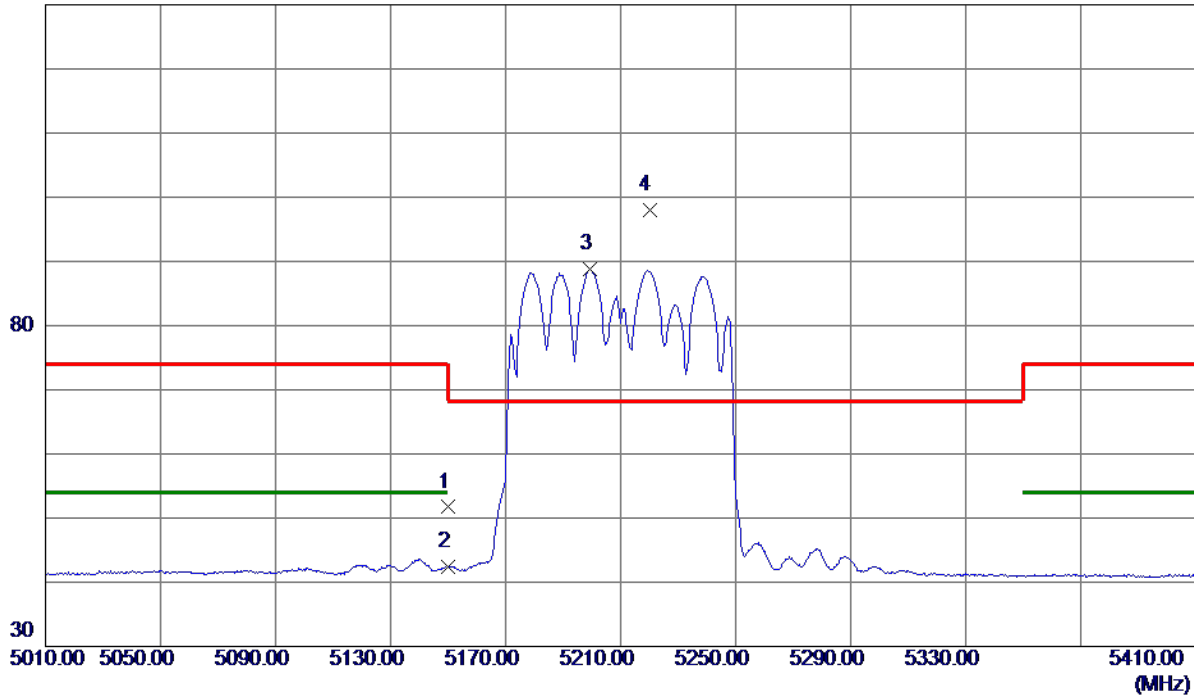

No.	Freq. MHz	Reading Level dBuV/m	Correct Factor dB	Measure ment dBuV/m	Limit dBuV/m	Margin dB	Detector	Comment
1	5150.0000	36.02	15.68	51.70	74.00	-22.30	Peak	
2	5150.0000	26.63	15.68	42.31	54.00	-11.69	AVG	
3	5199.4000	73.00	15.71	88.71	999.00	-910.29	AVG	No Limit
4 *	5220.0000	82.35	15.72	98.07	68.30	29.77	Peak	No Limit

REMARKS:

- (1) Measurement Value = Reading Level + Correct Factor.
- (2) Margin Level = Measurement Value - Limit Value.

Orthogonal Axis	X
Test Mode	UNII-1_TX AC (VHT80) Mode 5210 MHz

Vertical

80 dBuV/m

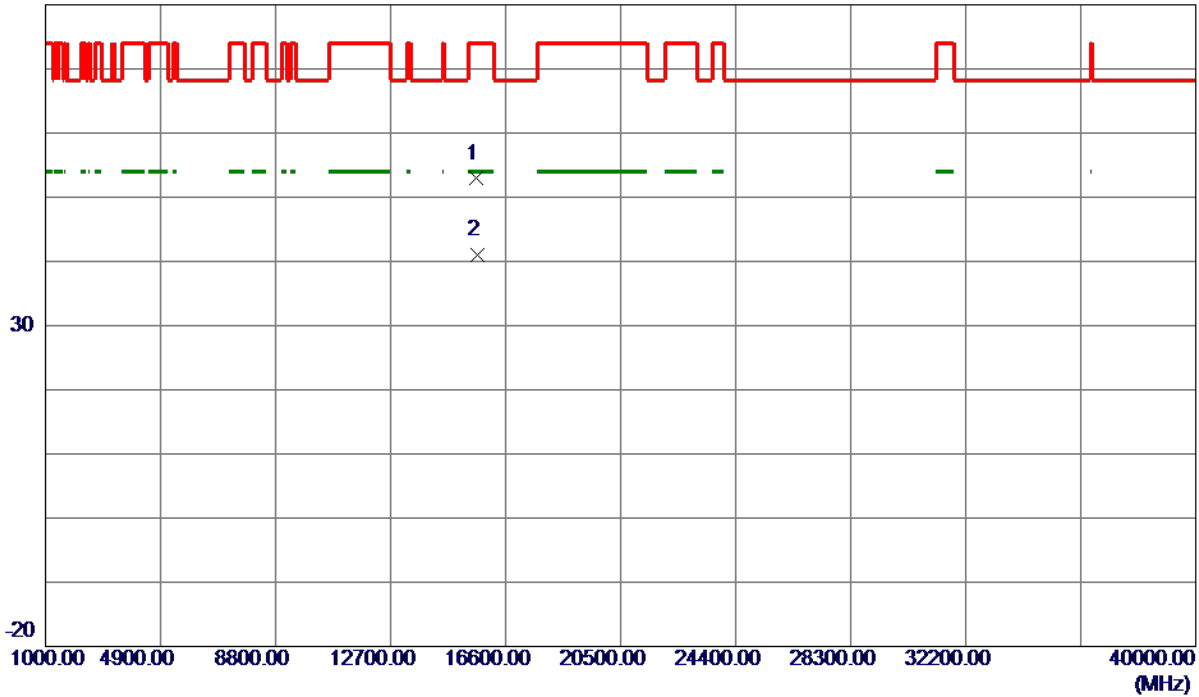

No.	Freq. MHz	Reading Level dBuV/m	Correct Factor dB	Measure ment dBuV/m	Limit dBuV/m	Margin dB	Detector	Comment
1	15621.0400	37.44	15.46	52.90	74.00	-21.10	Peak	
2 *	15635.5600	25.46	15.46	40.92	54.00	-13.08	AVG	

REMARKS:

- (1) Measurement Value = Reading Level + Correct Factor.
- (2) Margin Level = Measurement Value - Limit Value.

Orthogonal Axis	X
Test Mode	UNII-1_TX AC (VHT80) Mode 5210 MHz

Horizontal

130 dBuV/m

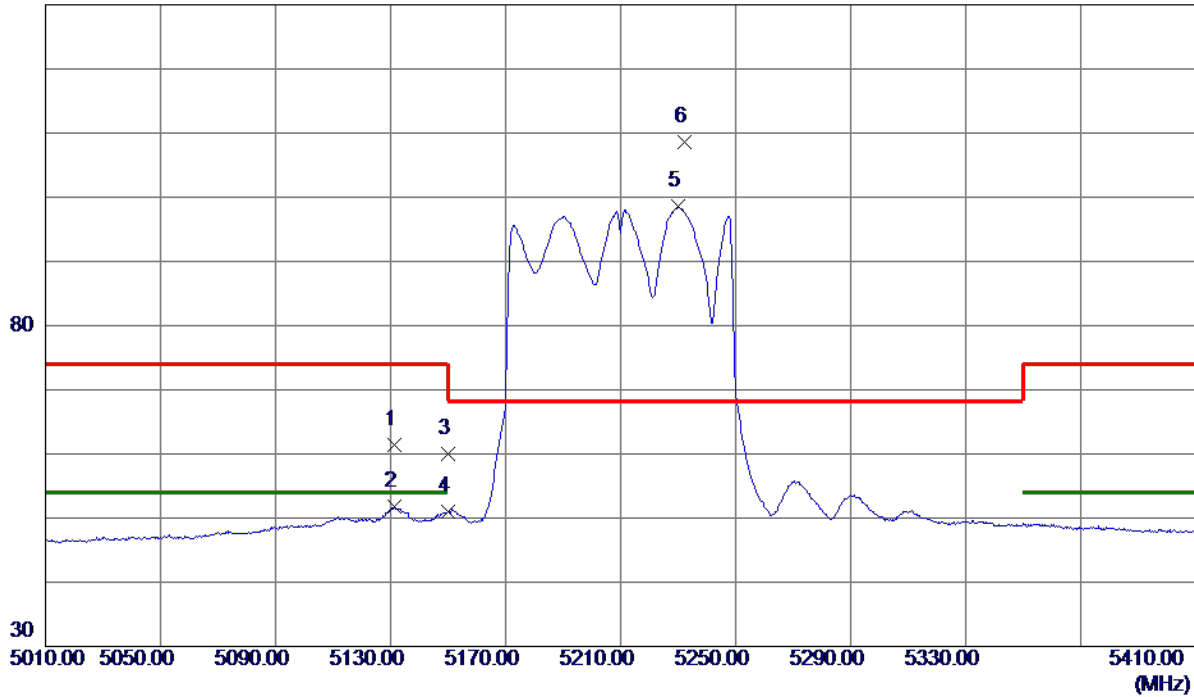

No.	Freq. MHz	Reading Level dBuV/m	Correct Factor dB	Measure ment dBuV/m	Limit dBuV/m	Margin dB	Detector	Comment
1	5131.2000	45.64	15.68	61.32	74.00	-12.68	Peak	
2	5131.2000	36.07	15.68	51.75	54.00	-2.25	AVG	
3	5150.0000	44.41	15.68	60.09	74.00	-13.91	Peak	
4	5150.0000	35.28	15.68	50.96	54.00	-3.04	AVG	
5	5229.8000	82.80	15.72	98.52	999.00	-900.48	AVG	No Limit
6 *	5232.2000	92.82	15.73	108.55	68.30	40.25	Peak	No Limit

REMARKS:

- (1) Measurement Value = Reading Level + Correct Factor.
- (2) Margin Level = Measurement Value - Limit Value.

Orthogonal Axis	X
Test Mode	UNII-1_TX AC (VHT80) Mode 5210 MHz

Horizontal

80 dBuV/m

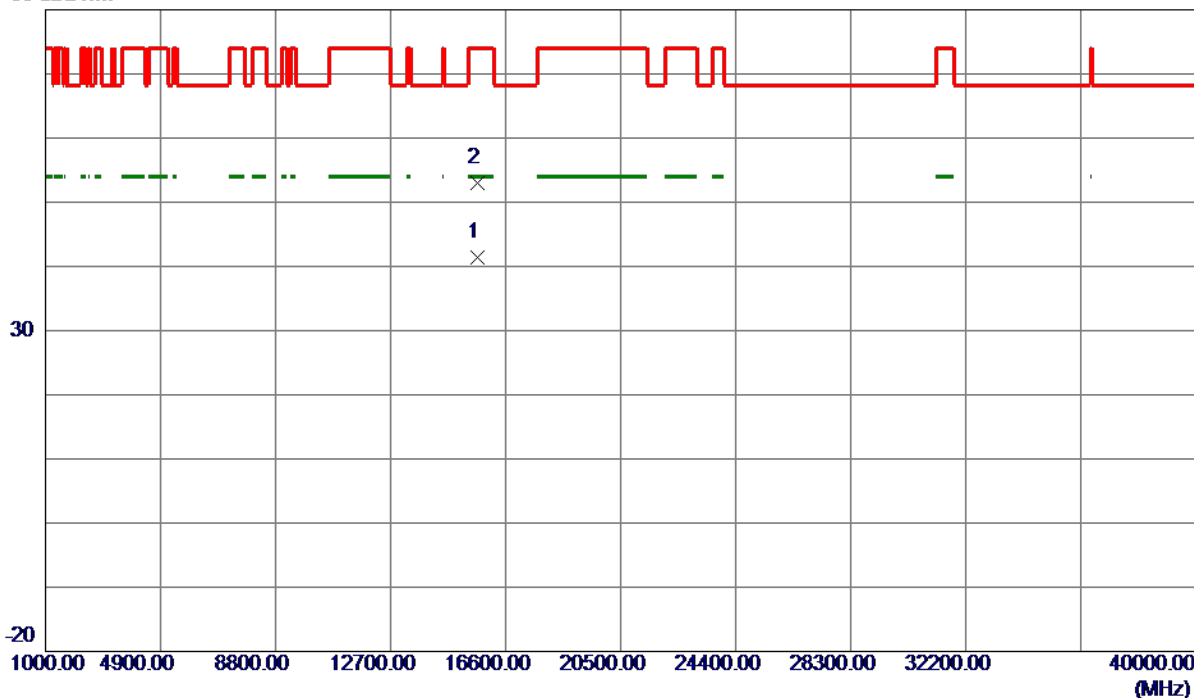

No.	Freq. MHz	Reading Level dBuV/m	Correct Factor dB	Measure ment dBuV/m	Limit dBuV/m	Margin dB	Detector	Comment
1 *	15633.0000	25.94	15.46	41.40	54.00	-12.60	AVG	
2	15636.8000	37.56	15.46	53.02	74.00	-20.98	Peak	

REMARKS:

- (1) Measurement Value = Reading Level + Correct Factor.
- (2) Margin Level = Measurement Value - Limit Value.

Orthogonal Axis	X
Test Mode	UNII-2A_TX AC (VHT20) Mode 5260 MHz

Vertical

130 dBuV/m

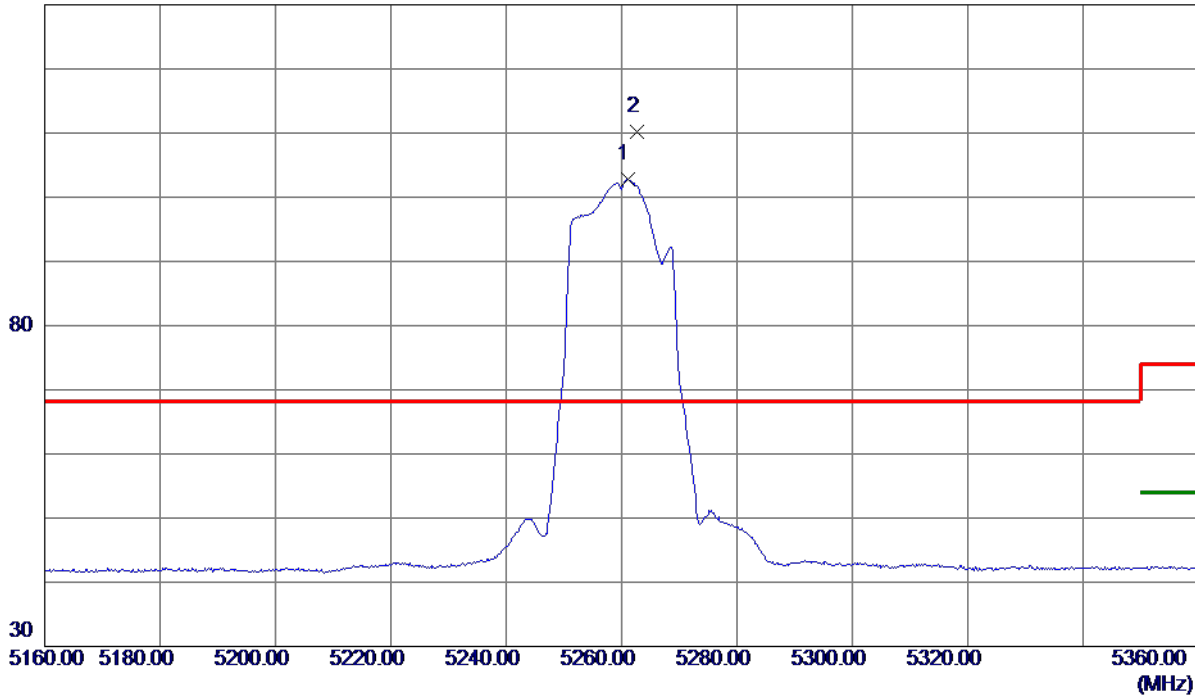

No.	Freq. MHz	Reading Level dBuV/m	Correct Factor dB	Measure ment dBuV/m	Limit dBuV/m	Margin dB	Detector	Comment
1	5261.0000	88.26	14.58	102.84	999.00	-896.16	AVG	No Limit
2 *	5262.6000	95.71	14.58	110.29	68.30	41.99	Peak	No Limit

REMARKS:

- (1) Measurement Value = Reading Level + Correct Factor.
- (2) Margin Level = Measurement Value - Limit Value.

Orthogonal Axis	X
Test Mode	UNII-2A_TX AC (VHT20) Mode 5260 MHz

Vertical

80 dBuV/m

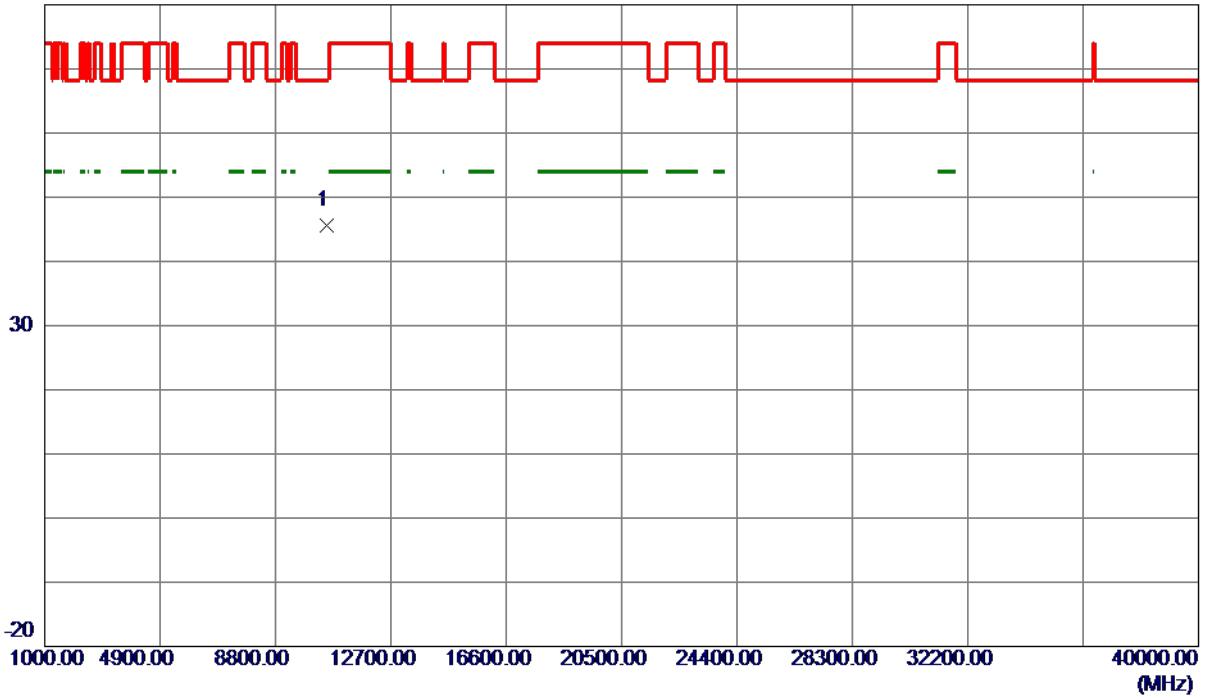

No.	Freq. MHz	Reading Level dBuV/m	Correct Factor dB	Measure ment dBuV/m	Limit dBuV/m	Margin dB	Detector	Comment
1 *	10523.6000	34.05	11.54	45.59	68.30	-22.71	Peak	

REMARKS:

- (1) Measurement Value = Reading Level + Correct Factor.
- (2) Margin Level = Measurement Value - Limit Value.

Orthogonal Axis	X
Test Mode	UNII-2A_TX AC (VHT20) Mode 5260 MHz

Horizontal

130 dBuV/m

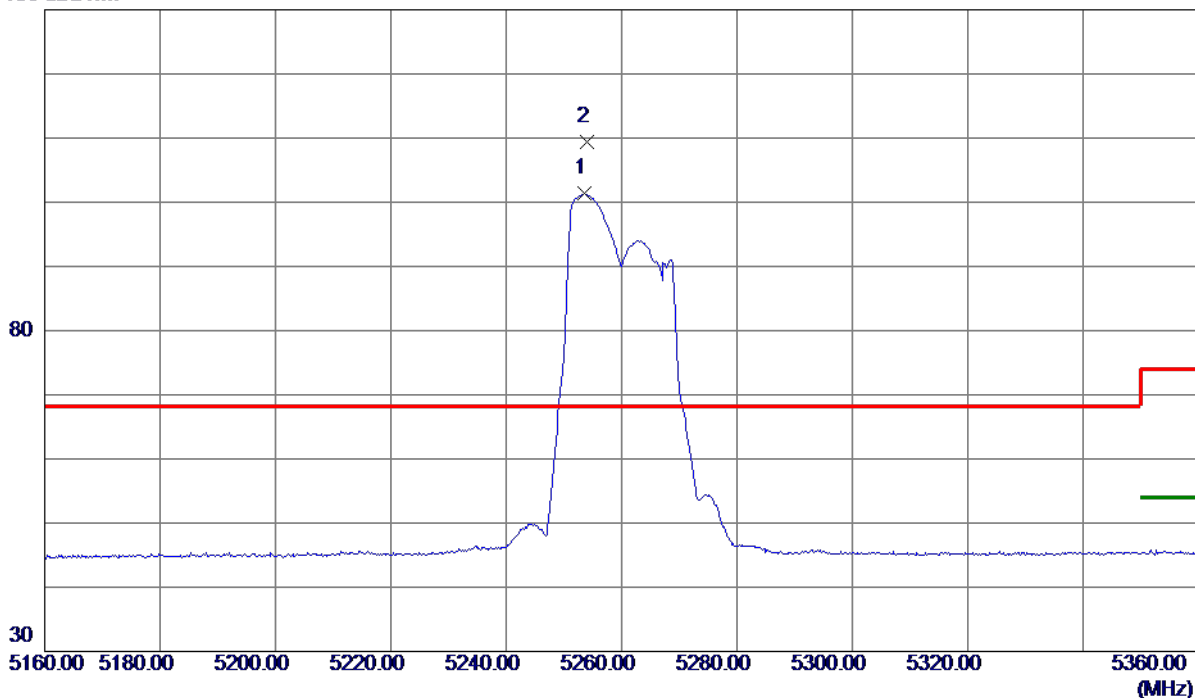

No.	Freq. MHz	Reading Level dBuV/m	Correct Factor dB	Measure ment dBuV/m	Limit dBuV/m	Margin dB	Detector	Comment
1	5253.6000	81.77	19.56	101.33	999.00	-897.67	AVG	No Limit
2 *	5254.0000	89.86	19.56	109.42	68.30	41.12	Peak	No Limit

REMARKS:

- (1) Measurement Value = Reading Level + Correct Factor.
- (2) Margin Level = Measurement Value - Limit Value.

Orthogonal Axis	X
Test Mode	UNII-2A_TX AC (VHT20) Mode 5260 MHz

Horizontal

80 dBuV/m

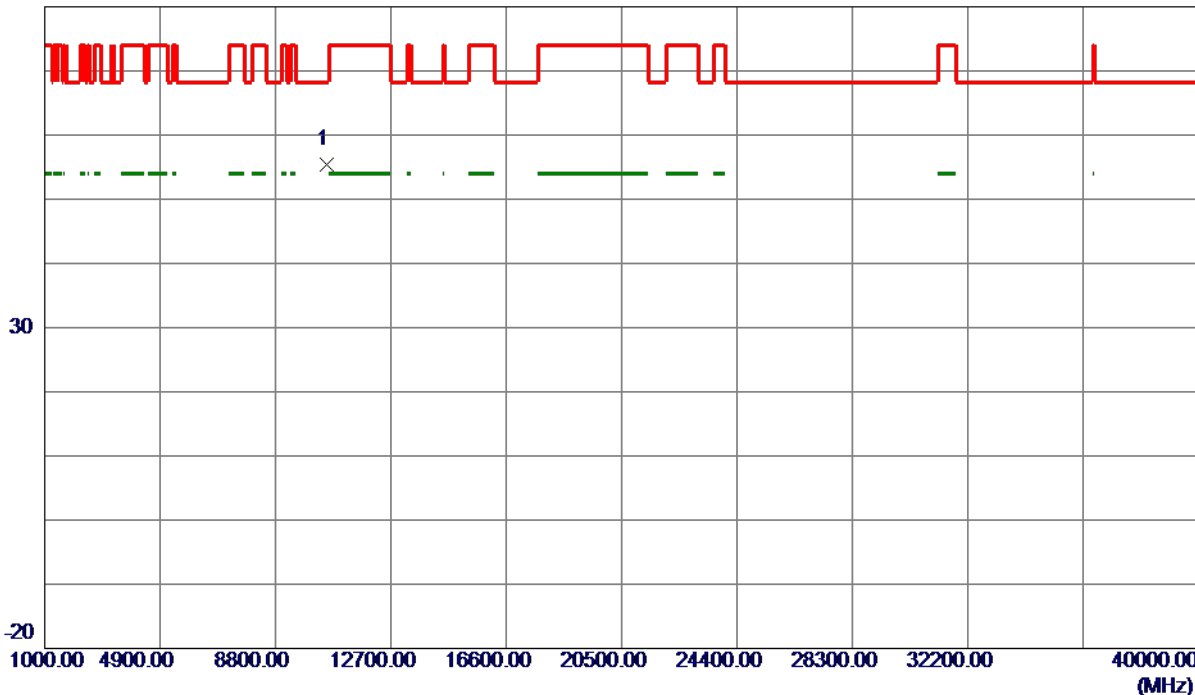

No.	Freq. MHz	Reading Level dBuV/m	Correct Factor dB	Measure ment dBuV/m	Limit dBuV/m	Margin dB	Detector	Comment
1 *	10528.8500	35.07	20.39	55.46	68.30	-12.84	Peak	

REMARKS:

- (1) Measurement Value = Reading Level + Correct Factor.
- (2) Margin Level = Measurement Value - Limit Value.

Orthogonal Axis	X
Test Mode	UNII-2A_TX AC (VHT20) Mode 5300 MHz

Vertical

130 dBuV/m

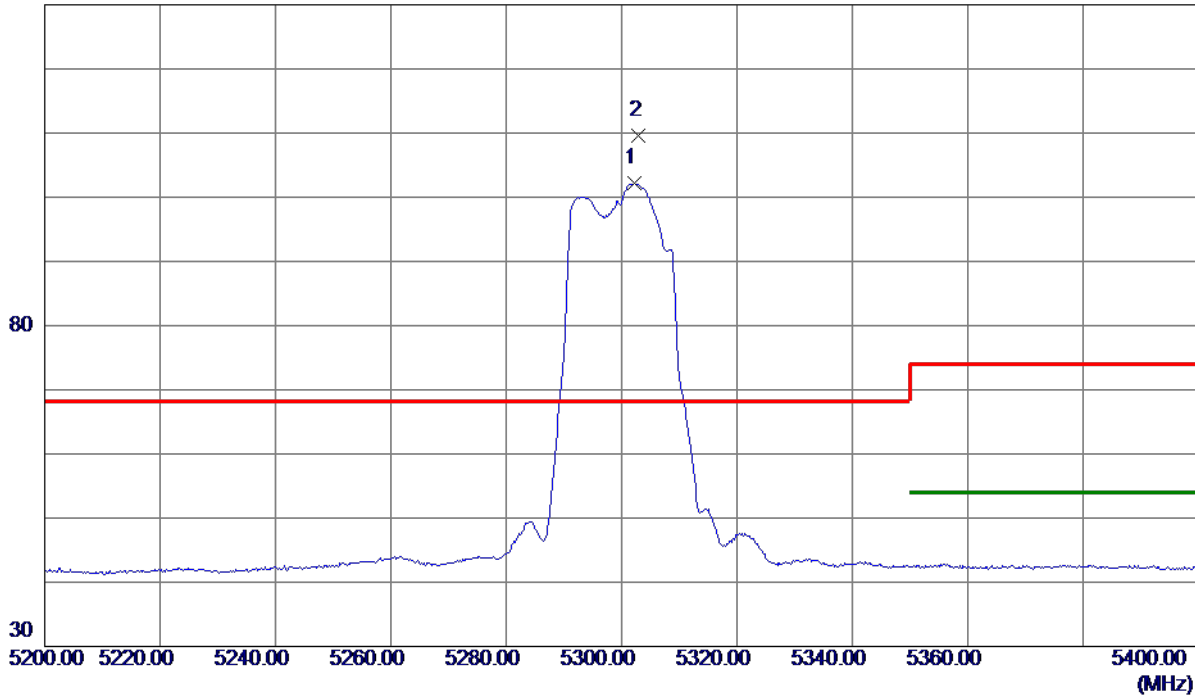

No.	Freq. MHz	Reading Level dBuV/m	Correct Factor dB	Measure ment dBuV/m	Limit dBuV/m	Margin dB	Detector	Comment
1	5302.2000	87.46	14.68	102.14	999.00	-896.86	AVG	No Limit
2 *	5303.0000	95.01	14.68	109.69	68.30	41.39	Peak	No Limit

REMARKS:

- (1) Measurement Value = Reading Level + Correct Factor.
- (2) Margin Level = Measurement Value - Limit Value.

Orthogonal Axis	X
Test Mode	UNII-2A_TX AC (VHT20) Mode 5300 MHz

Vertical

80 dBuV/m

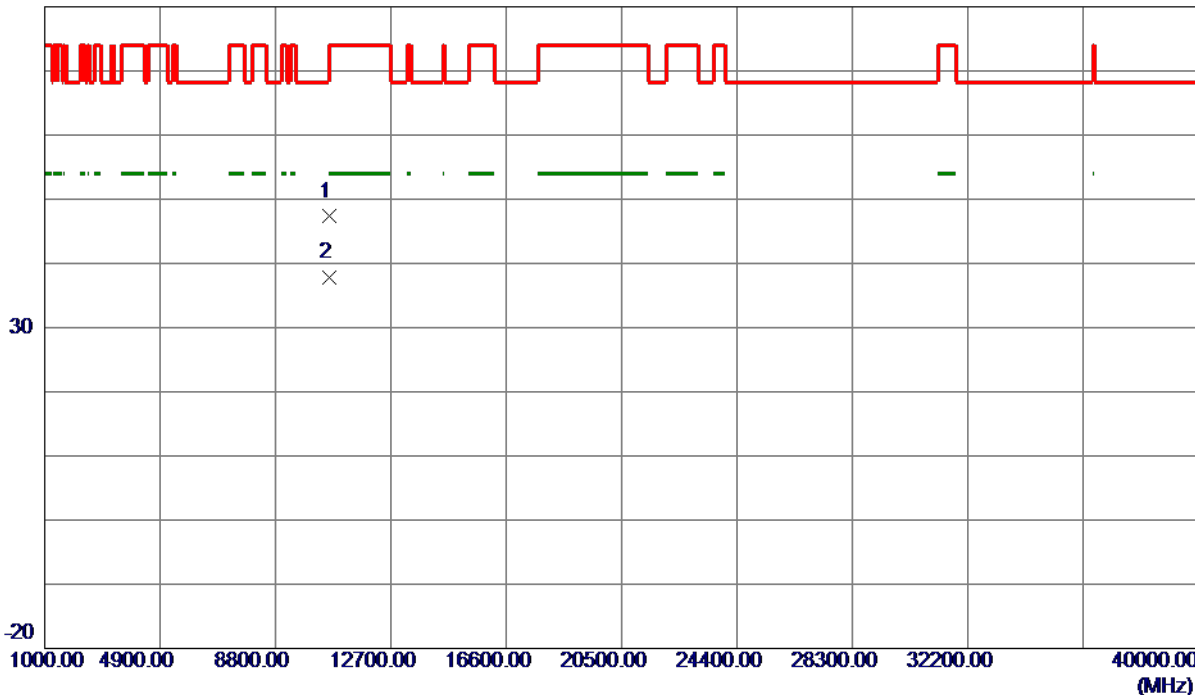

No.	Freq. MHz	Reading Level dBuV/m	Correct Factor dB	Measure ment dBuV/m	Limit dBuV/m	Margin dB	Detector	Comment
1	10604.4000	35.75	11.55	47.30	74.00	-26.70	Peak	
2 *	10606.9900	26.34	11.55	37.89	54.00	-16.11	AVG	

REMARKS:

- (1) Measurement Value = Reading Level + Correct Factor.
- (2) Margin Level = Measurement Value - Limit Value.

Orthogonal Axis	X
Test Mode	UNII-2A_TX AC (VHT20) Mode 5300 MHz

Horizontal

130 dBuV/m

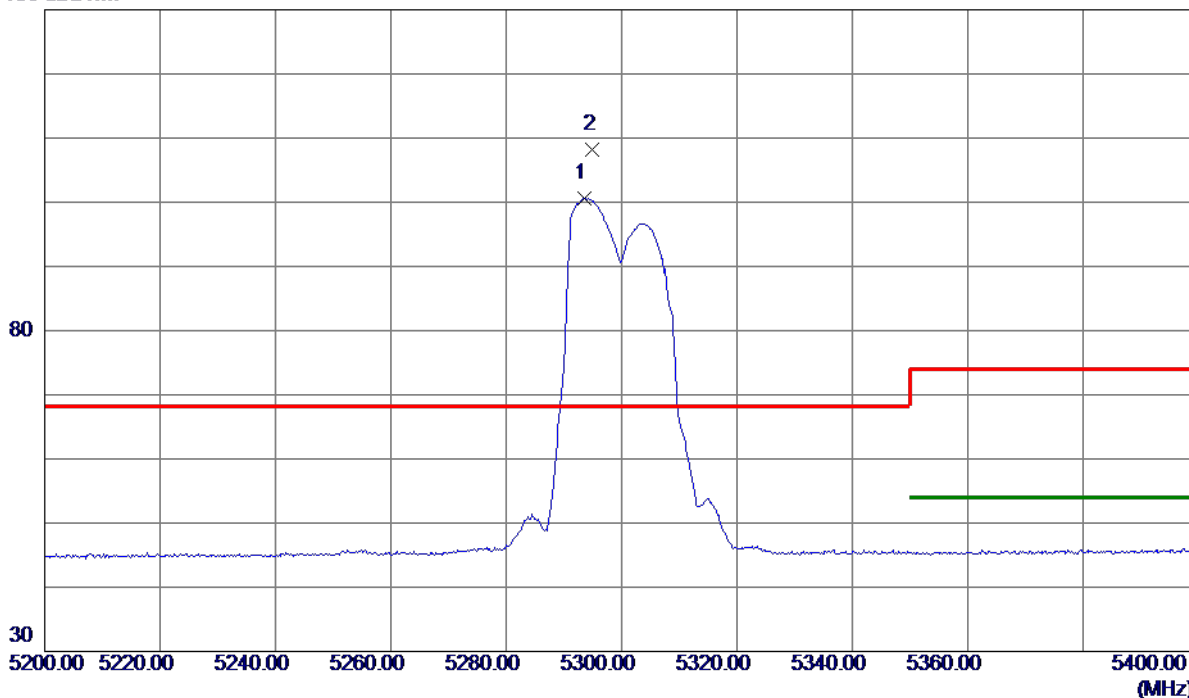

No.	Freq. MHz	Reading Level dBuV/m	Correct Factor dB	Measure ment dBuV/m	Limit dBuV/m	Margin dB	Detector	Comment
1	5293.6000	80.84	19.70	100.54	999.00	-898.46	AVG	No Limit
2 *	5295.0000	88.53	19.71	108.24	68.30	39.94	Peak	No Limit

REMARKS:

- (1) Measurement Value = Reading Level + Correct Factor.
- (2) Margin Level = Measurement Value - Limit Value.

Orthogonal Axis	X
Test Mode	UNII-2A_TX AC (VHT20) Mode 5300 MHz

Horizontal

80 dBuV/m

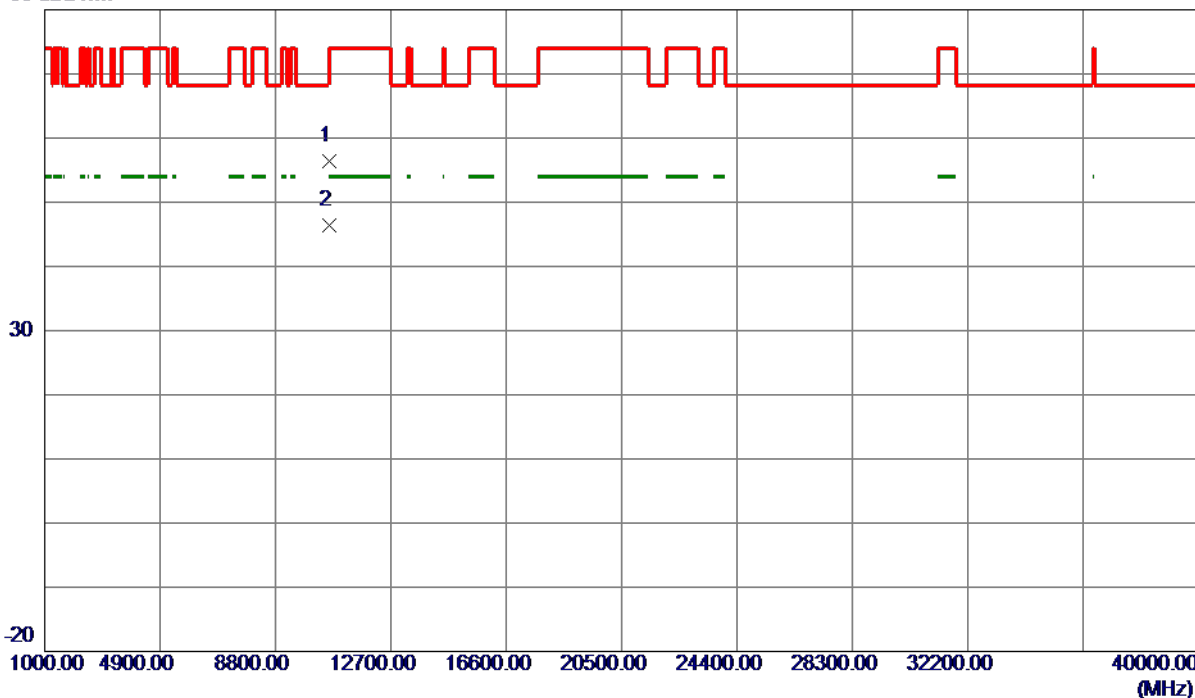

No.	Freq. MHz	Reading Level dBuV/m	Correct Factor dB	Measure ment dBuV/m	Limit dBuV/m	Margin dB	Detector	Comment
1	10600.4500	35.96	20.43	56.39	74.00	-17.61	Peak	
2 *	10600.8500	25.93	20.43	46.36	54.00	-7.64	AVG	

REMARKS:

- (1) Measurement Value = Reading Level + Correct Factor.
- (2) Margin Level = Measurement Value - Limit Value.

Orthogonal Axis	X
Test Mode	UNII-2A_TX AC (VHT20) Mode 5320 MHz

Vertical

130 dBuV/m

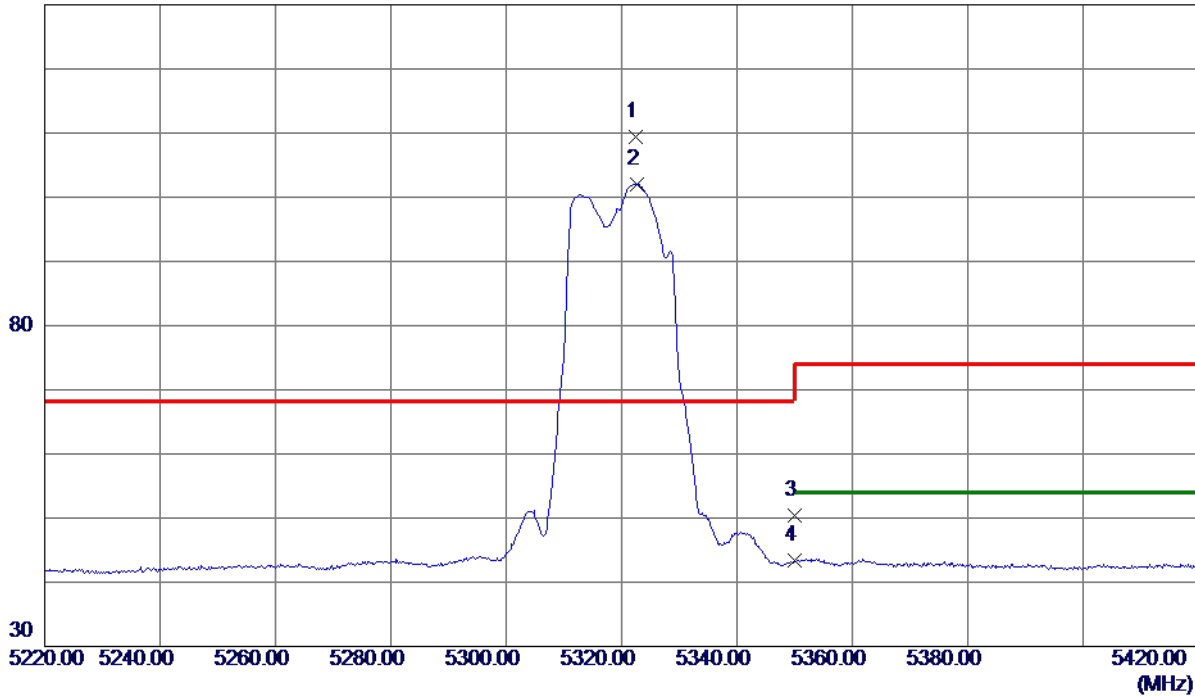

No.	Freq. MHz	Reading Level dBuV/m	Correct Factor dB	Measure ment dBuV/m	Limit dBuV/m	Margin dB	Detector	Comment
1 *	5322.4000	94.69	14.72	109.41	68.30	41.11	Peak	No Limit
2	5322.6000	87.25	14.72	101.97	999.00	-897.03	AVG	No Limit
3	5350.0000	35.69	14.79	50.48	74.00	-23.52	Peak	
4	5350.0000	28.62	14.79	43.41	999.00	-955.59	AVG	

REMARKS:

- (1) Measurement Value = Reading Level + Correct Factor.
- (2) Margin Level = Measurement Value - Limit Value.

Orthogonal Axis	X
Test Mode	UNII-2A_TX AC (VHT20) Mode 5320 MHz

Vertical

80 dBuV/m

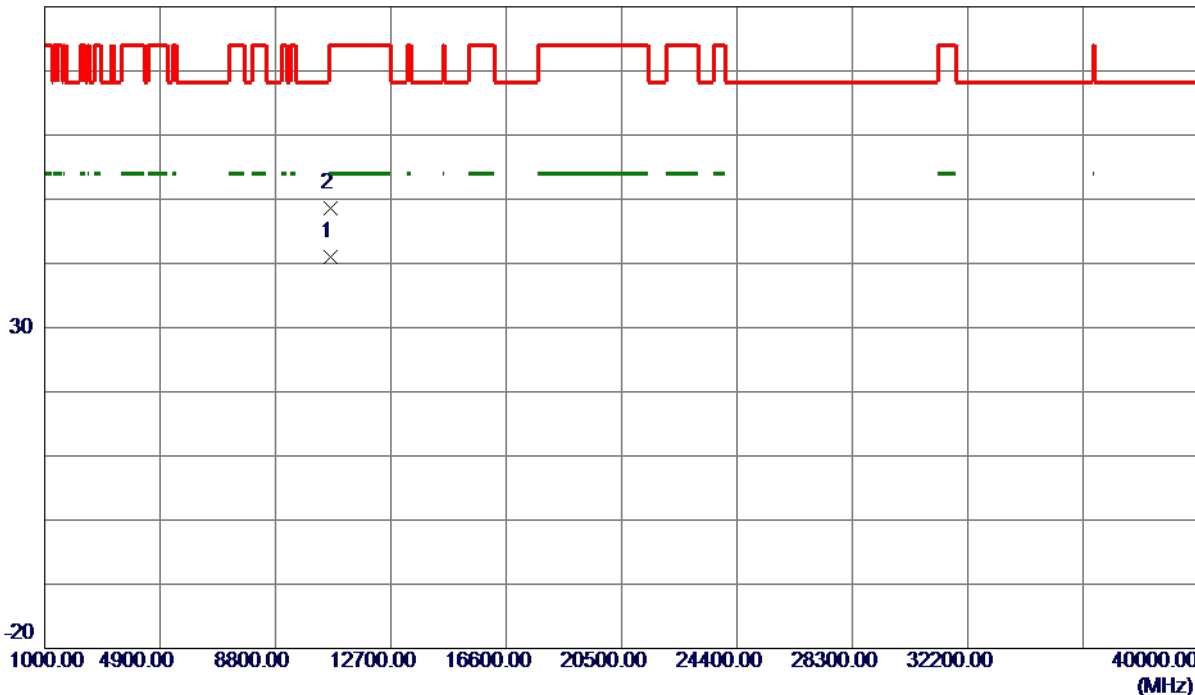

No.	Freq. MHz	Reading Level dBuV/m	Correct Factor dB	Measure ment dBuV/m	Limit dBuV/m	Margin dB	Detector	Comment
1 *	10641.6800	29.47	11.56	41.03	54.00	-12.97	AVG	
2	10643.2000	37.05	11.56	48.61	74.00	-25.39	Peak	

REMARKS:

- (1) Measurement Value = Reading Level + Correct Factor.
- (2) Margin Level = Measurement Value - Limit Value.

Orthogonal Axis	X
Test Mode	UNII-2A_TX AC (VHT20) Mode 5320 MHz

Horizontal

130 dBuV/m

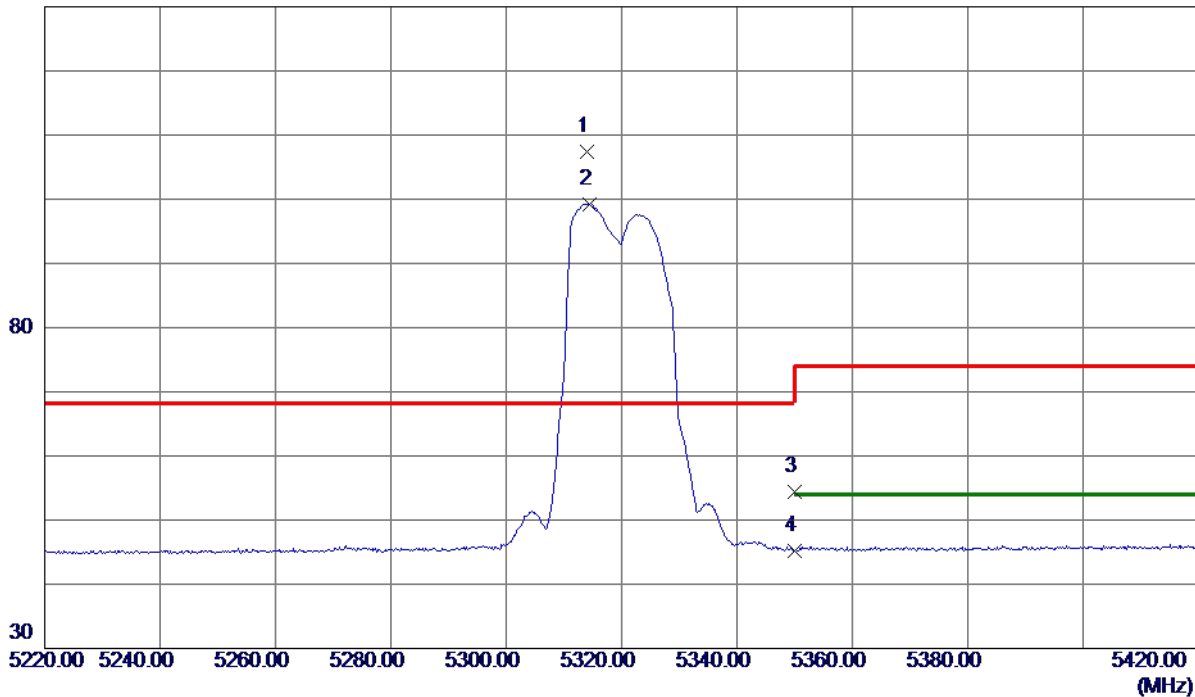

No.	Freq. MHz	Reading Level dBuV/m	Correct Factor dB	Measure ment dBuV/m	Limit dBuV/m	Margin dB	Detector	Comment
1 *	5314.0000	87.69	19.78	107.47	68.30	39.17	Peak	No Limit
2	5314.4000	79.48	19.78	99.26	999.00	-899.74	AVG	No Limit
3	5350.0000	34.43	19.91	54.34	74.00	-19.66	Peak	
4	5350.0000	25.31	19.91	45.22	999.00	-953.78	AVG	

REMARKS:

- (1) Measurement Value = Reading Level + Correct Factor.
- (2) Margin Level = Measurement Value - Limit Value.

Orthogonal Axis	X
Test Mode	UNII-2A_TX AC (VHT20) Mode 5320 MHz

Horizontal

80 dBuV/m

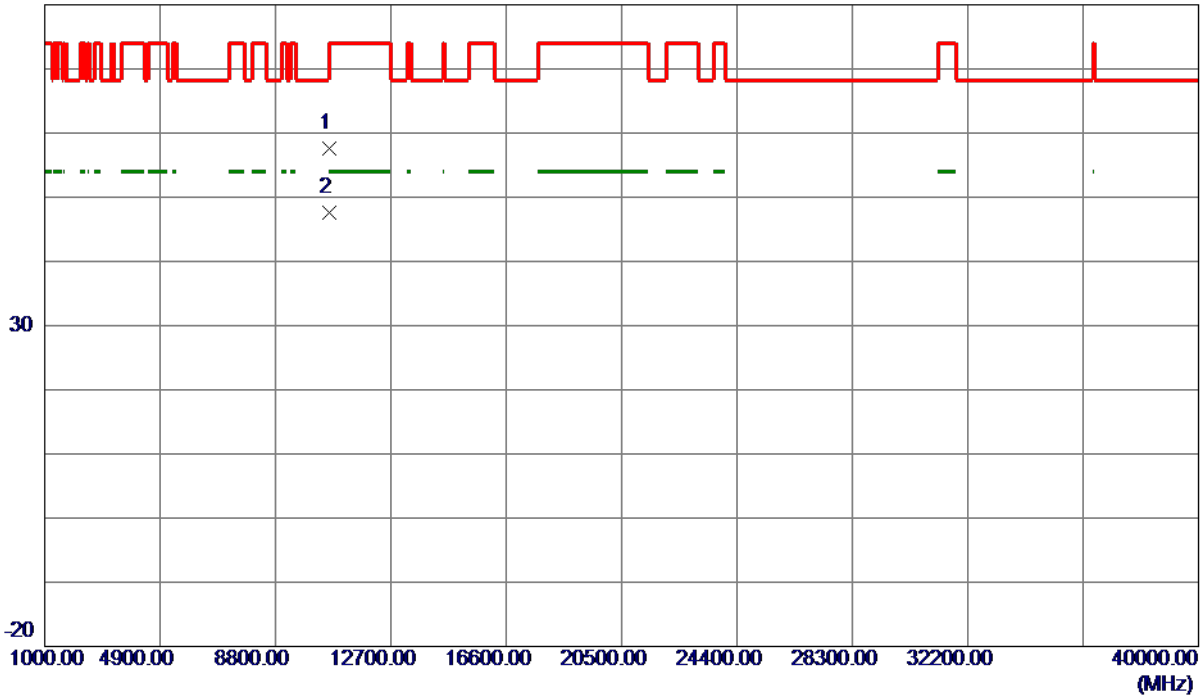

No.	Freq. MHz	Reading Level dBuV/m	Correct Factor dB	Measure ment dBuV/m	Limit dBuV/m	Margin dB	Detector	Comment
1	10637.4000	37.10	20.46	57.56	74.00	-16.44	Peak	
2 *	10637.4500	27.21	20.46	47.67	54.00	-6.33	AVG	

REMARKS:

- (1) Measurement Value = Reading Level + Correct Factor.
- (2) Margin Level = Measurement Value - Limit Value.

Orthogonal Axis	X
Test Mode	UNII-2A_TX AC (VHT40) Mode 5270 MHz

Vertical

130 dBuV/m

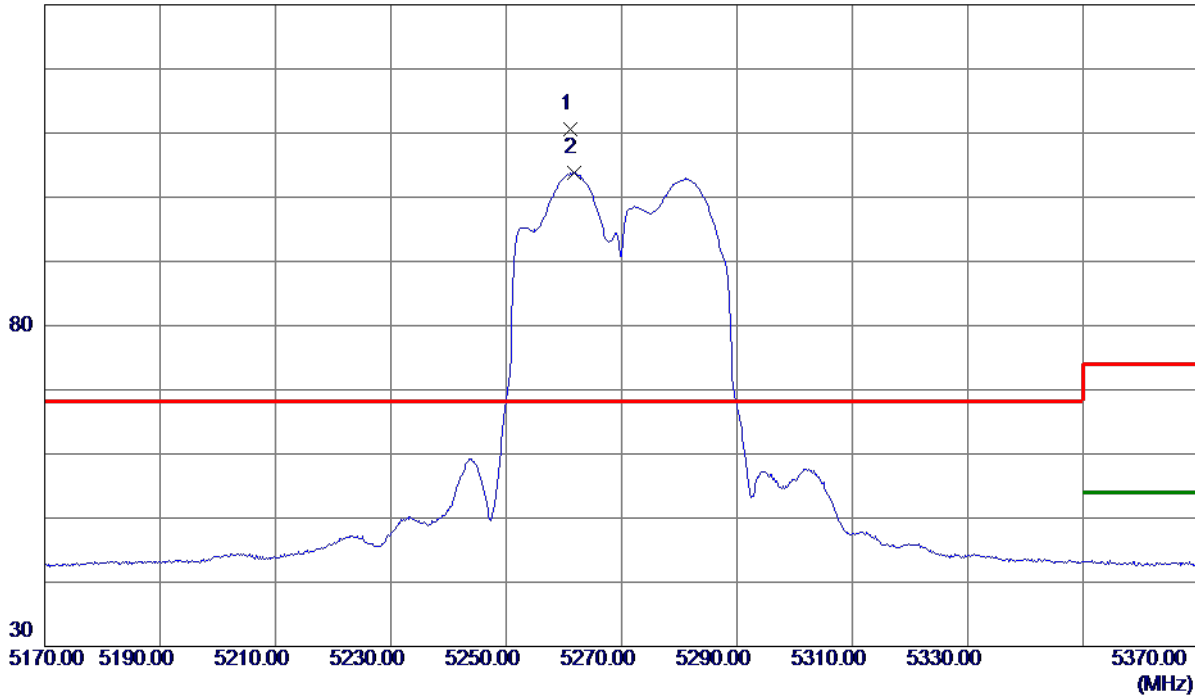

No.	Freq. MHz	Reading Level dBuV/m	Correct Factor dB	Measure ment dBuV/m	Limit dBuV/m	Margin dB	Detector	Comment
1 *	5261.2000	96.01	14.58	110.59	68.30	42.29	Peak	No Limit
2	5261.8000	89.24	14.58	103.82	999.00	-895.18	AVG	No Limit

REMARKS:

- (1) Measurement Value = Reading Level + Correct Factor.
- (2) Margin Level = Measurement Value - Limit Value.

Orthogonal Axis	X
Test Mode	UNII-2A_TX AC (VHT40) Mode 5270 MHz

Vertical

80 dBuV/m

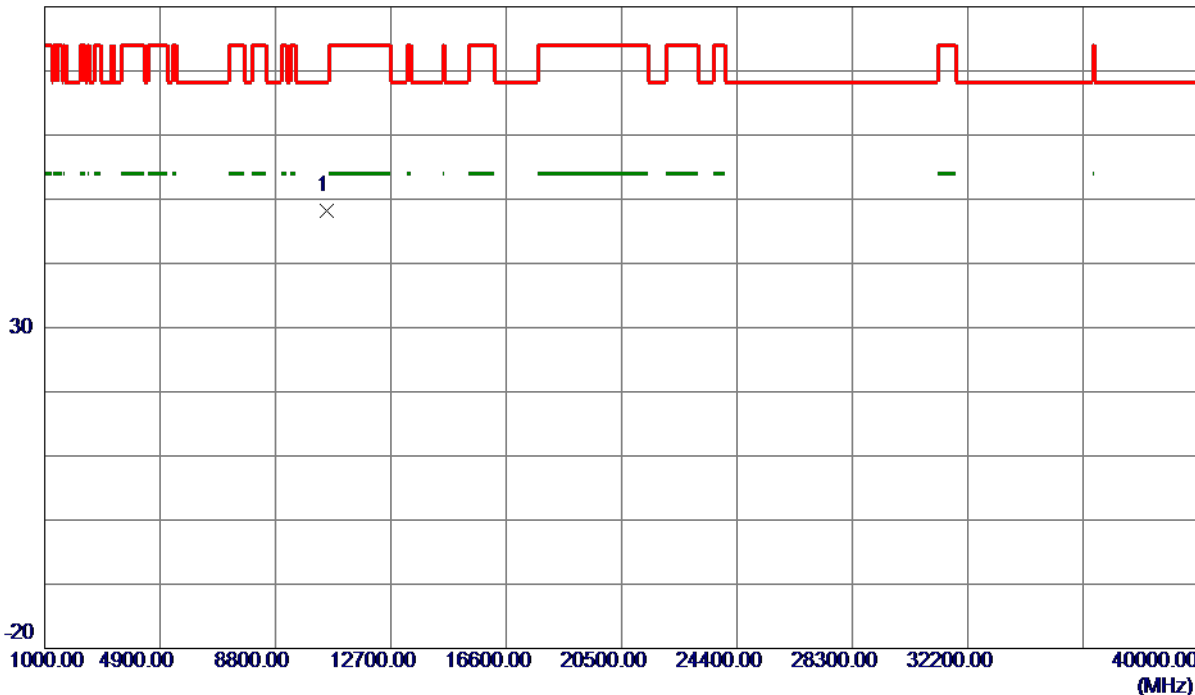

No.	Freq. MHz	Reading Level dBuV/m	Correct Factor dB	Measure ment dBuV/m	Limit dBuV/m	Margin dB	Detector	Comment
1 *	10543.2000	36.73	11.54	48.27	68.30	-20.03	Peak	

REMARKS:

- (1) Measurement Value = Reading Level + Correct Factor.
- (2) Margin Level = Measurement Value - Limit Value.

Orthogonal Axis	X
Test Mode	UNII-2A_TX AC (VHT40) Mode 5270 MHz

Horizontal

130 dBuV/m

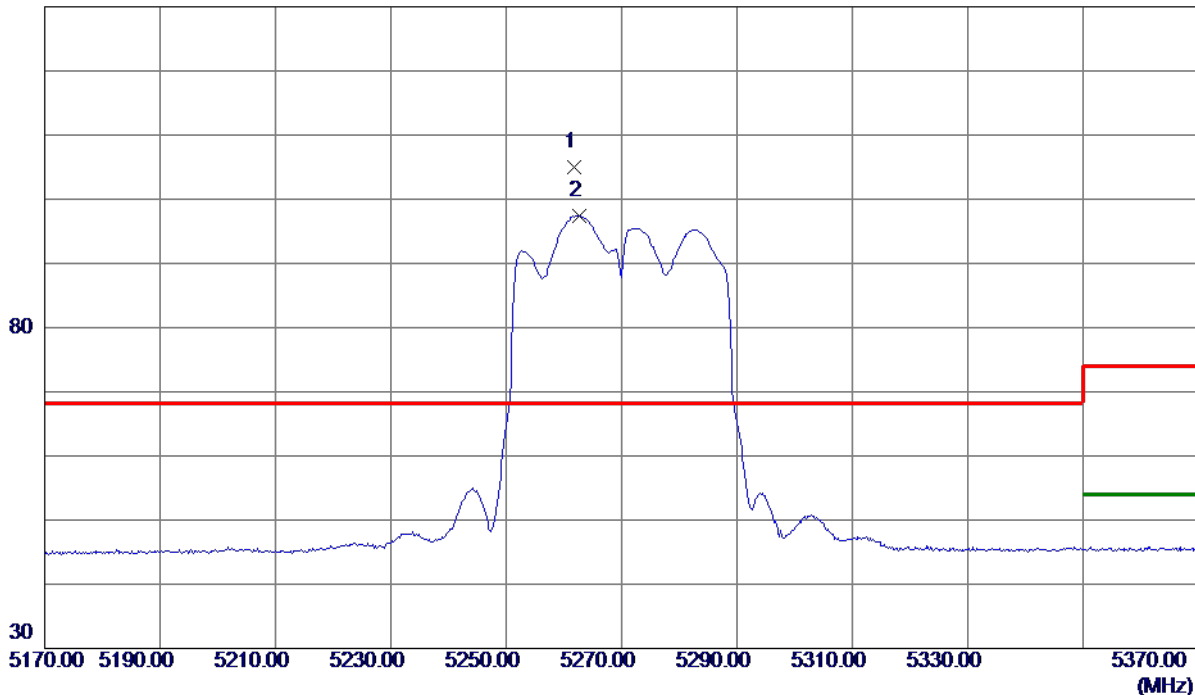

No.	Freq. MHz	Reading Level dBuV/m	Correct Factor dB	Measure ment dBuV/m	Limit dBuV/m	Margin dB	Detector	Comment
1 *	5261.8000	85.34	19.59	104.93	68.30	36.63	Peak	No Limit
2	5262.6000	77.90	19.59	97.49	999.00	-901.51	AVG	No Limit

REMARKS:

- (1) Measurement Value = Reading Level + Correct Factor.
- (2) Margin Level = Measurement Value - Limit Value.

Orthogonal Axis	X
Test Mode	UNII-2A_TX AC (VHT40) Mode 5270 MHz

Horizontal

80 dBuV/m

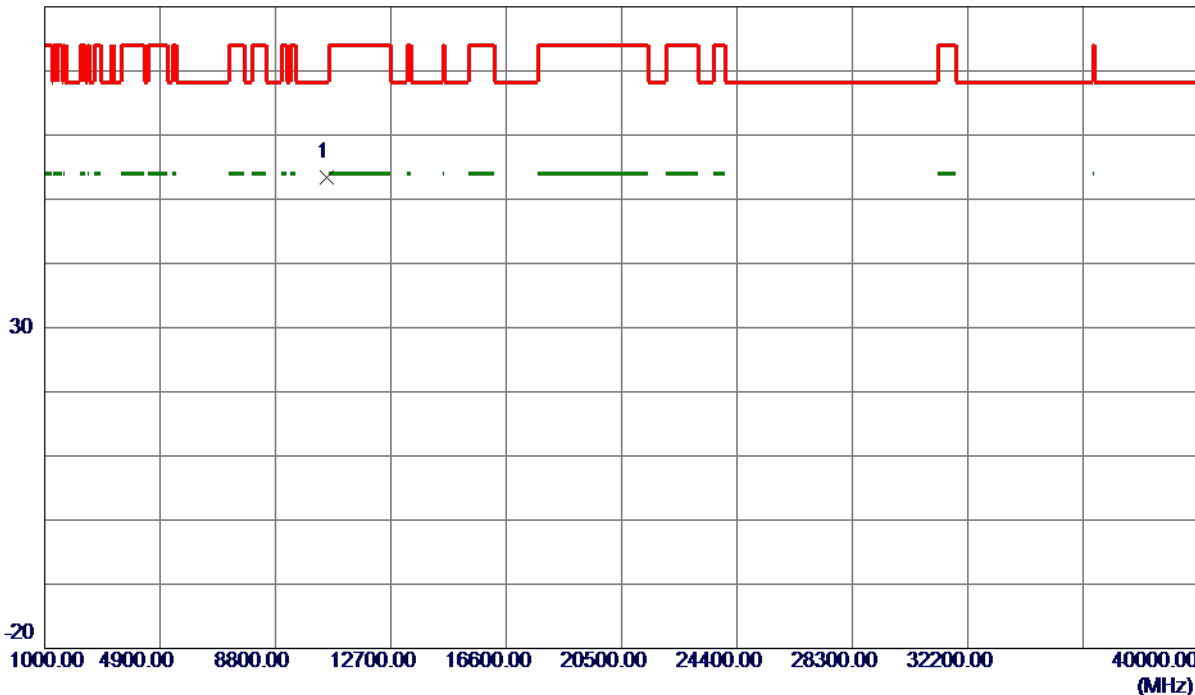

No.	Freq. MHz	Reading Level dBuV/m	Correct Factor dB	Measure ment dBuV/m	Limit dBuV/m	Margin dB	Detector	Comment
1 *	10548.7000	33.05	20.40	53.45	68.30	-14.85	Peak	

REMARKS:

- (1) Measurement Value = Reading Level + Correct Factor.
- (2) Margin Level = Measurement Value - Limit Value.

Orthogonal Axis	X
Test Mode	UNII-2A_TX AC (VHT40) Mode 5310 MHz

Vertical

130 dBuV/m

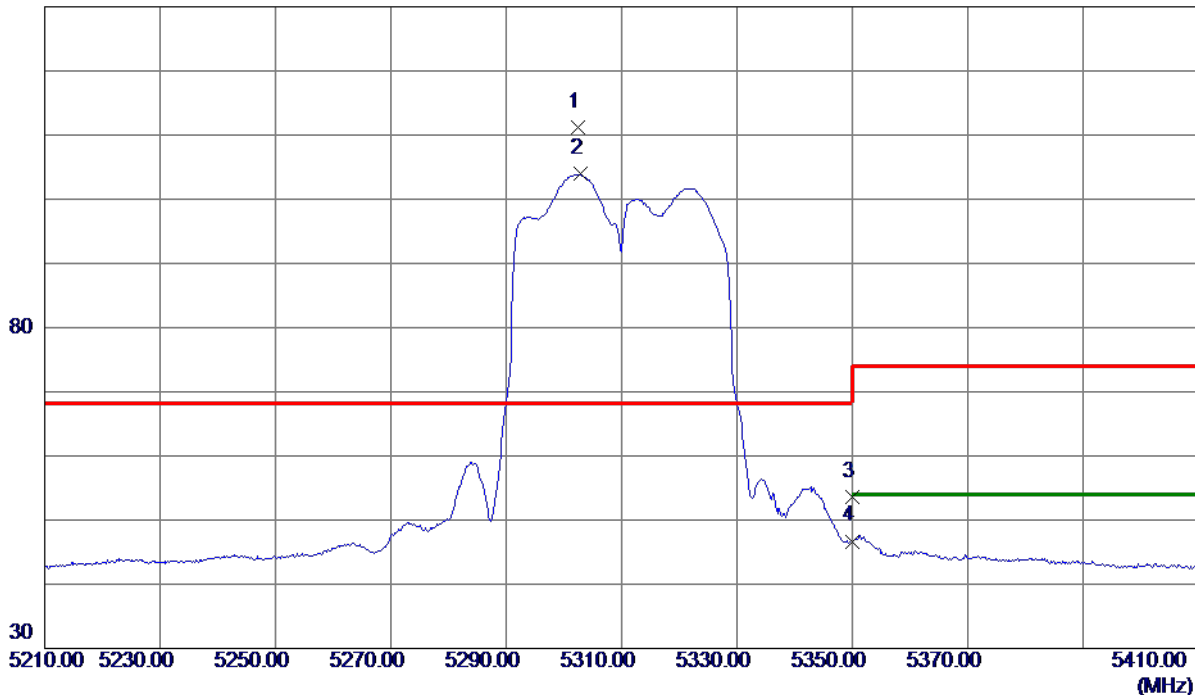

No.	Freq. MHz	Reading Level dBuV/m	Correct Factor dB	Measure ment dBuV/m	Limit dBuV/m	Margin dB	Detector	Comment
1 *	5302.4000	96.58	14.68	111.26	68.30	42.96	Peak	No Limit
2	5302.8000	89.25	14.68	103.93	999.00	-895.07	AVG	No Limit
3	5350.0000	38.84	14.79	53.63	74.00	-20.37	Peak	
4	5350.0000	31.91	14.79	46.70	999.00	-952.30	AVG	

REMARKS:

- (1) Measurement Value = Reading Level + Correct Factor.
- (2) Margin Level = Measurement Value - Limit Value.

Orthogonal Axis	X
Test Mode	UNII-2A_TX AC (VHT40) Mode 5310 MHz

Vertical

80 dBuV/m

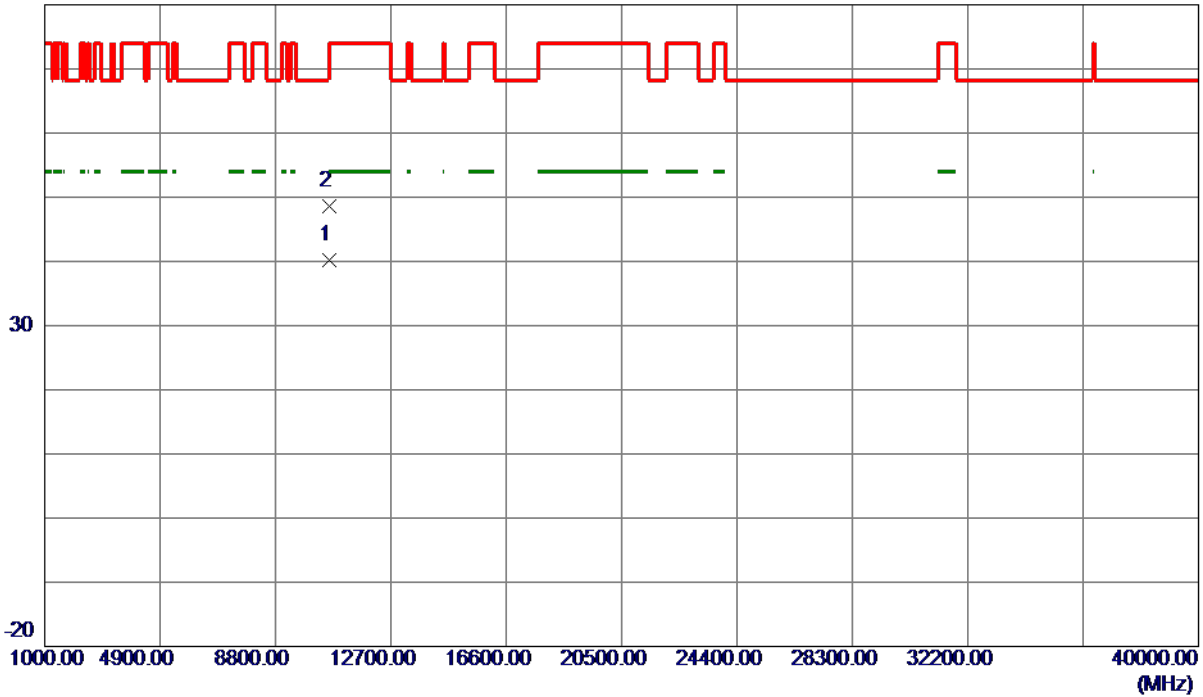

No.	Freq. MHz	Reading Level dBuV/m	Correct Factor dB	Measure ment dBuV/m	Limit dBuV/m	Margin dB	Detector	Comment
1 *	10621.4000	28.62	11.56	40.18	54.00	-13.82	AVG	
2	10624.4000	37.10	11.56	48.66	74.00	-25.34	Peak	

REMARKS:

- (1) Measurement Value = Reading Level + Correct Factor.
- (2) Margin Level = Measurement Value - Limit Value.

Orthogonal Axis	X
Test Mode	UNII-2A_TX AC (VHT40) Mode 5310 MHz

Horizontal

130 dBuV/m



No.	Freq. MHz	Reading Level dBuV/m	Correct Factor dB	Measure ment dBuV/m	Limit dBuV/m	Margin dB	Detector	Comment
1	5304.2000	77.82	19.74	97.56	999.00	-901.44	AVG	No Limit
2 *	5304.4000	84.60	19.74	104.34	68.30	36.04	Peak	No Limit
3	5350.0000	33.32	19.91	53.23	74.00	-20.77	Peak	
4	5350.0000	26.15	19.91	46.06	999.00	-952.94	AVG	

REMARKS:

- (1) Measurement Value = Reading Level + Correct Factor.
- (2) Margin Level = Measurement Value - Limit Value.

Orthogonal Axis	X
Test Mode	UNII-2A_TX AC (VHT40) Mode 5310 MHz

Horizontal

80 dBuV/m

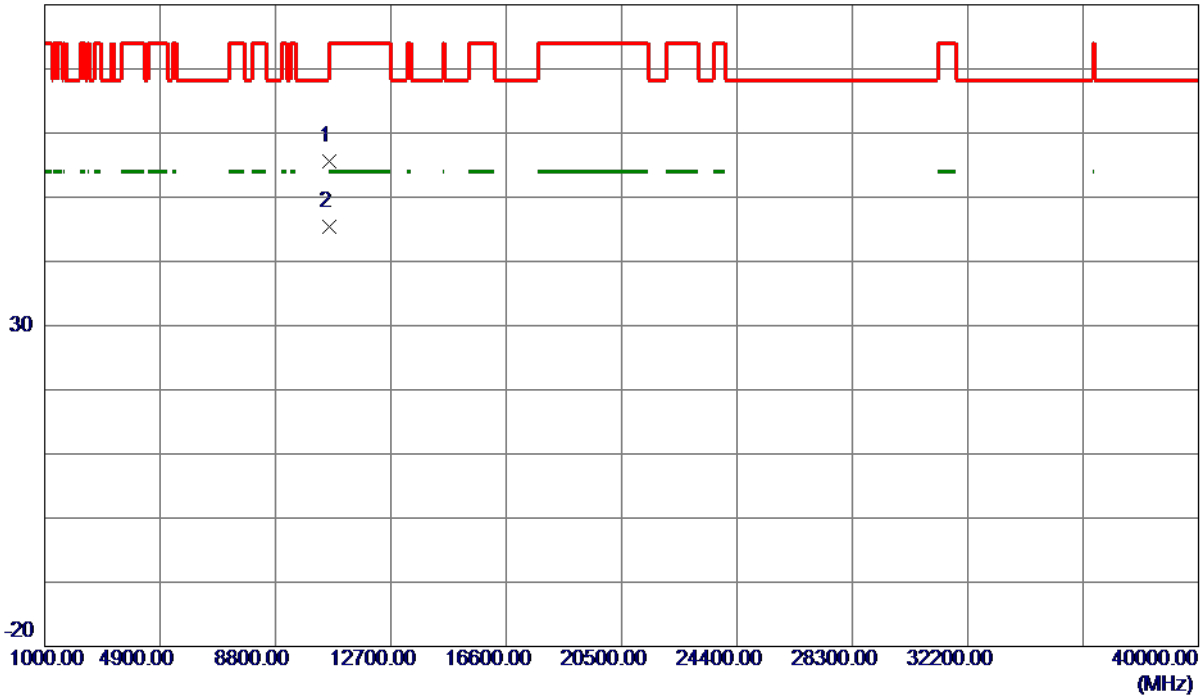

No.	Freq. MHz	Reading Level dBuV/m	Correct Factor dB	Measure ment dBuV/m	Limit dBuV/m	Margin dB	Detector	Comment
1	10616.8000	35.23	20.44	55.67	74.00	-18.33	Peak	
2 *	10617.0500	24.97	20.44	45.41	54.00	-8.59	AVG	

REMARKS:

- (1) Measurement Value = Reading Level + Correct Factor.
- (2) Margin Level = Measurement Value - Limit Value.

Orthogonal Axis	X
Test Mode	UNII-2A_TX AC (VHT80) Mode 5290 MHz

Vertical

130 dBuV/m

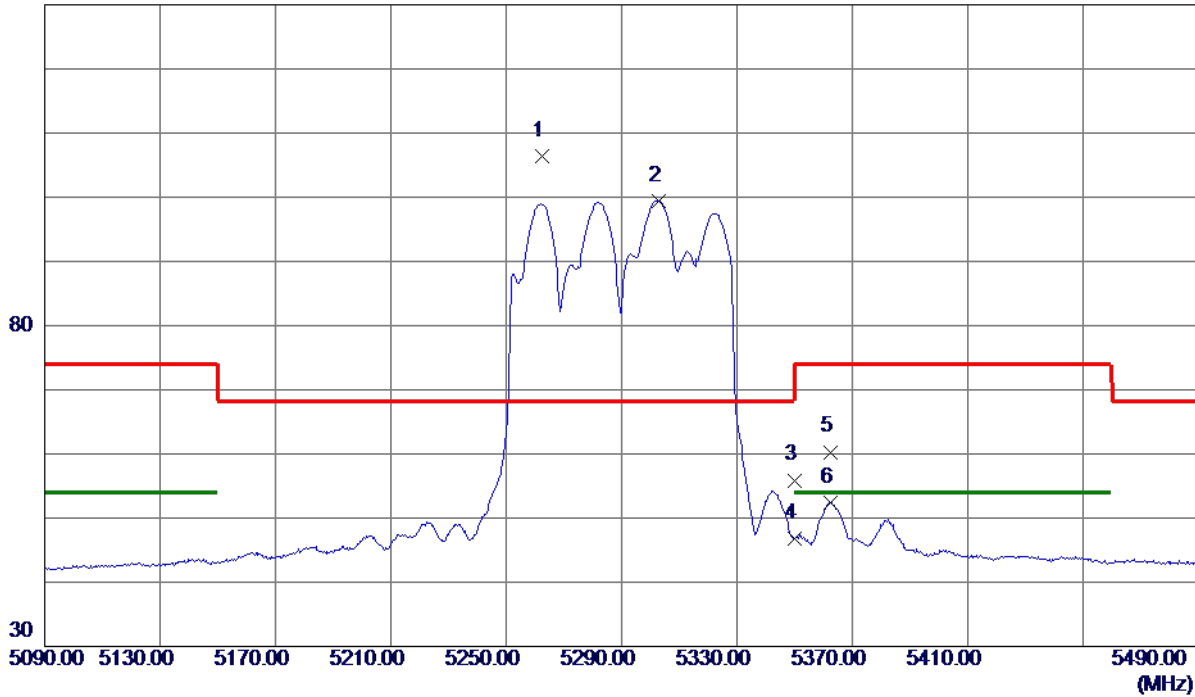

No.	Freq. MHz	Reading Level dBuV/m	Correct Factor dB	Measure ment dBuV/m	Limit dBuV/m	Margin dB	Detector	Comment
1 *	5262.4000	91.80	14.58	106.38	68.30	38.08	Peak	No Limit
2	5302.8000	84.78	14.68	99.46	999.00	-899.54	AVG	No Limit
3	5350.0000	41.11	14.79	55.90	74.00	-18.10	Peak	
4	5350.0000	31.97	14.79	46.76	999.00	-952.24	AVG	
5	5362.4000	45.48	14.82	60.30	74.00	-13.70	Peak	
6	5362.4000	37.64	14.82	52.46	54.00	-1.54	AVG	

REMARKS:

- (1) Measurement Value = Reading Level + Correct Factor.
- (2) Margin Level = Measurement Value - Limit Value.

Orthogonal Axis	X
Test Mode	UNII-2A_TX AC (VHT80) Mode 5290 MHz

Vertical

80 dBuV/m

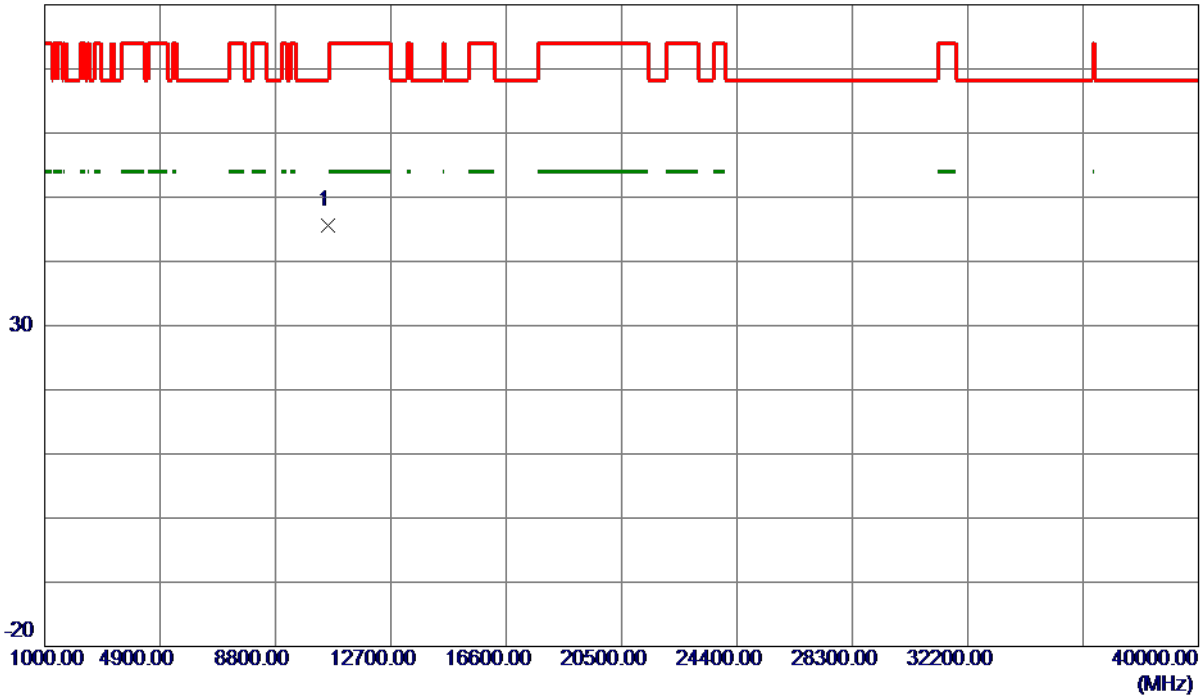

No.	Freq. MHz	Reading Level dBuV/m	Correct Factor dB	Measure ment dBuV/m	Limit dBuV/m	Margin dB	Detector	Comment
1 *	10563.6000	34.14	11.55	45.69	68.30	-22.61	Peak	

REMARKS:

- (1) Measurement Value = Reading Level + Correct Factor.
- (2) Margin Level = Measurement Value - Limit Value.

Orthogonal Axis	X
Test Mode	UNII-2A_TX AC (VHT80) Mode 5290 MHz

Horizontal

130 dBuV/m

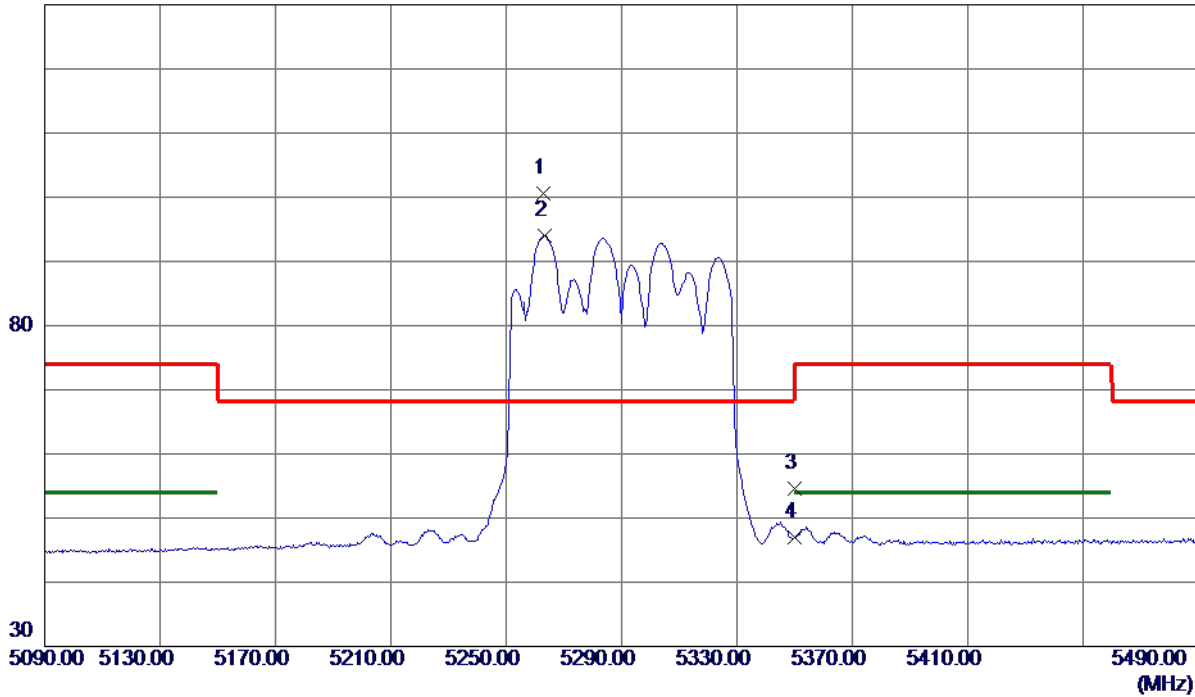

No.	Freq. MHz	Reading Level dBuV/m	Correct Factor dB	Measure ment dBuV/m	Limit dBuV/m	Margin dB	Detector	Comment
1 *	5262.8000	80.94	19.59	100.53	68.30	32.23	Peak	No Limit
2	5263.2000	74.38	19.59	93.97	999.00	-905.03	AVG	No Limit
3	5350.0000	34.70	19.91	54.61	74.00	-19.39	Peak	
4	5350.0000	27.09	19.91	47.00	999.00	-952.00	AVG	

REMARKS:

- (1) Measurement Value = Reading Level + Correct Factor.
- (2) Margin Level = Measurement Value - Limit Value.

Orthogonal Axis	X
Test Mode	UNII-2A_TX AC (VHT80) Mode 5290 MHz

Horizontal

80 dBuV/m

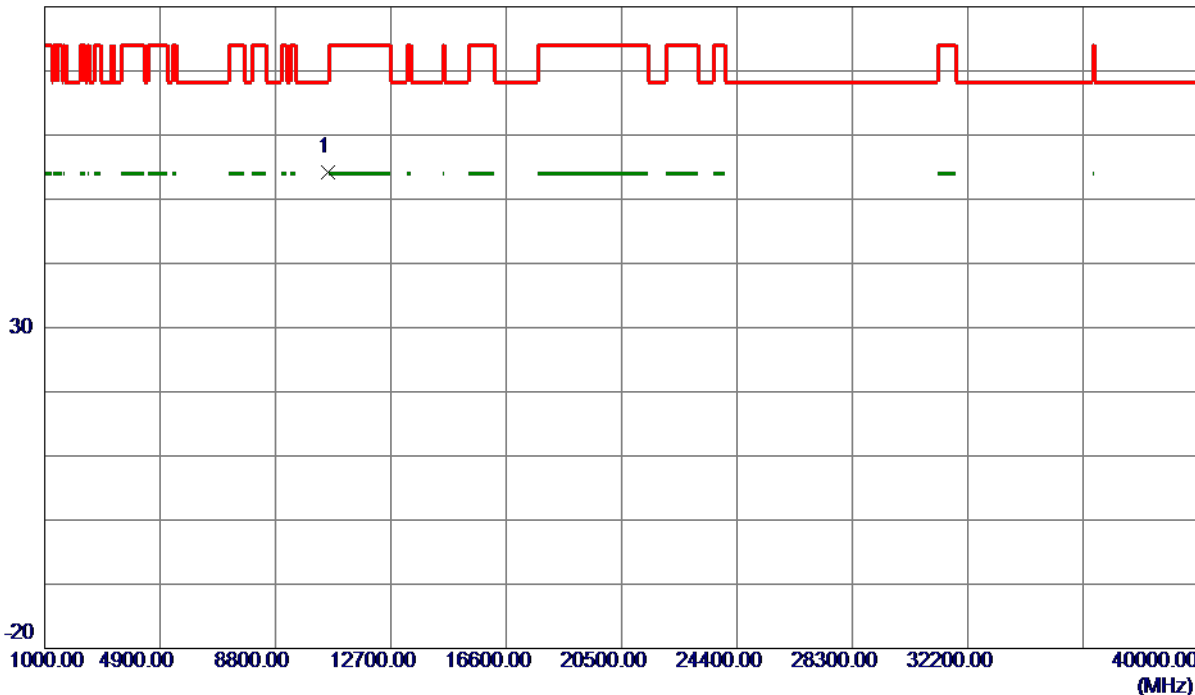

No.	Freq. MHz	Reading Level dBuV/m	Correct Factor dB	Measure ment dBuV/m	Limit dBuV/m	Margin dB	Detector	Comment
1 *	10597.2500	33.80	20.43	54.23	68.30	-14.07	Peak	

REMARKS:

- (1) Measurement Value = Reading Level + Correct Factor.
- (2) Margin Level = Measurement Value - Limit Value.

Orthogonal Axis	X
Test Mode	UNII-2C_TX AC (VHT20) Mode 5500 MHz

Vertical

130 dBuV/m

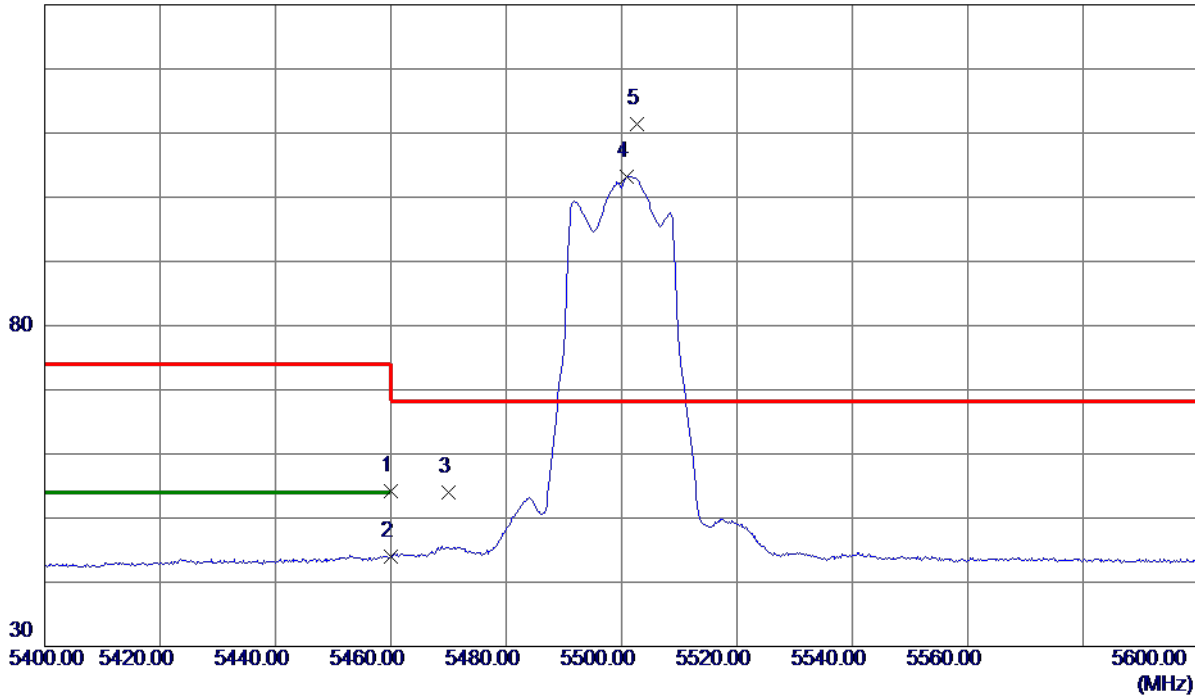

No.	Freq. MHz	Reading Level dBuV/m	Correct Factor dB	Measure ment dBuV/m	Limit dBuV/m	Margin dB	Detector	Comment
1	5460.0000	39.17	15.05	54.22	74.00	-19.78	Peak	
2	5460.0000	28.89	15.05	43.94	54.00	-10.06	AVG	
3	5470.0000	38.90	15.07	53.97	68.30	-14.33	Peak	
4	5500.8000	88.13	15.15	103.28	999.00	-895.72	AVG	No Limit
5 *	5502.6000	96.27	15.15	111.42	68.30	43.12	Peak	No Limit

REMARKS:

- (1) Measurement Value = Reading Level + Correct Factor.
- (2) Margin Level = Measurement Value - Limit Value.

Orthogonal Axis	X
Test Mode	UNII-2C_TX AC (VHT20) Mode 5500 MHz

Vertical

80 dBuV/m

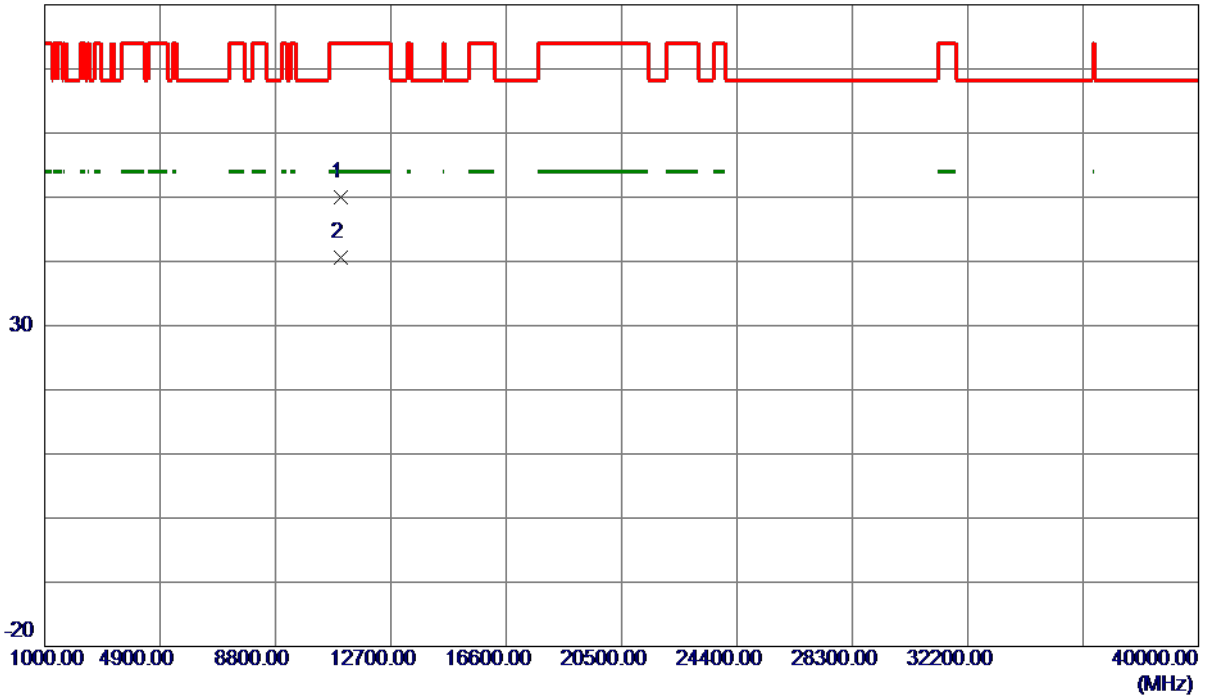

No.	Freq. MHz	Reading Level dBuV/m	Correct Factor dB	Measure ment dBuV/m	Limit dBuV/m	Margin dB	Detector	Comment
1	10998.4000	38.46	11.62	50.08	74.00	-23.92	Peak	
2 *	10999.2000	29.02	11.62	40.64	54.00	-13.36	AVG	

REMARKS:

- (1) Measurement Value = Reading Level + Correct Factor.
- (2) Margin Level = Measurement Value - Limit Value.

Orthogonal Axis	X
Test Mode	UNII-2C_TX AC (VHT20) Mode 5500 MHz

Horizontal

130 dBuV/m

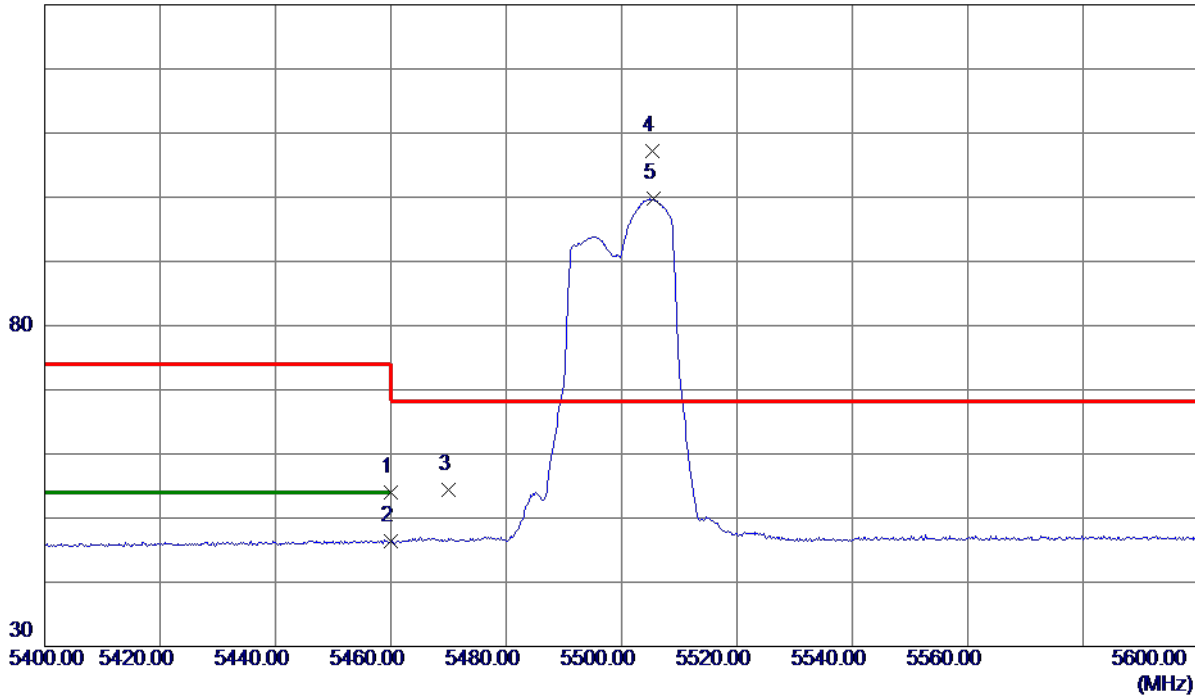

No.	Freq. MHz	Reading Level dBuV/m	Correct Factor dB	Measure ment dBuV/m	Limit dBuV/m	Margin dB	Detector	Comment
1	5460.0000	33.74	20.31	54.05	74.00	-19.95	Peak	
2	5460.0000	26.03	20.31	46.34	54.00	-7.66	AVG	
3	5470.0000	34.10	20.35	54.45	68.30	-13.85	Peak	
4 *	5505.4000	86.70	20.48	107.18	68.30	38.88	Peak	No Limit
5	5505.6000	79.27	20.48	99.75	999.00	-899.25	AVG	No Limit

REMARKS:

- (1) Measurement Value = Reading Level + Correct Factor.
- (2) Margin Level = Measurement Value - Limit Value.

Orthogonal Axis	X
Test Mode	UNII-2C_TX AC (VHT20) Mode 5500 MHz

Horizontal

80 dBuV/m

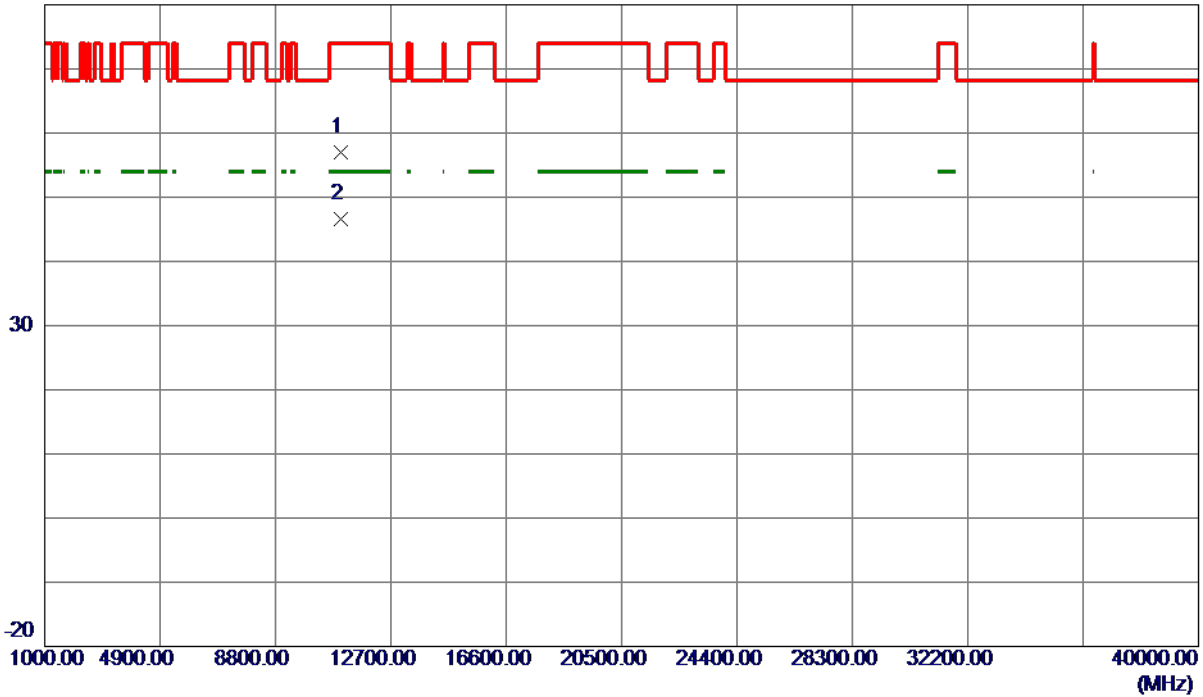

No.	Freq. MHz	Reading Level dBuV/m	Correct Factor dB	Measure ment dBuV/m	Limit dBuV/m	Margin dB	Detector	Comment
1	11001.2000	36.32	20.67	56.99	74.00	-17.01	Peak	
2 *	11002.9000	26.03	20.66	46.69	54.00	-7.31	AVG	

REMARKS:

- (1) Measurement Value = Reading Level + Correct Factor.
- (2) Margin Level = Measurement Value - Limit Value.

Orthogonal Axis	X
Test Mode	UNII-2C_TX AC (VHT20) Mode 5580 MHz

Vertical

130 dBuV/m

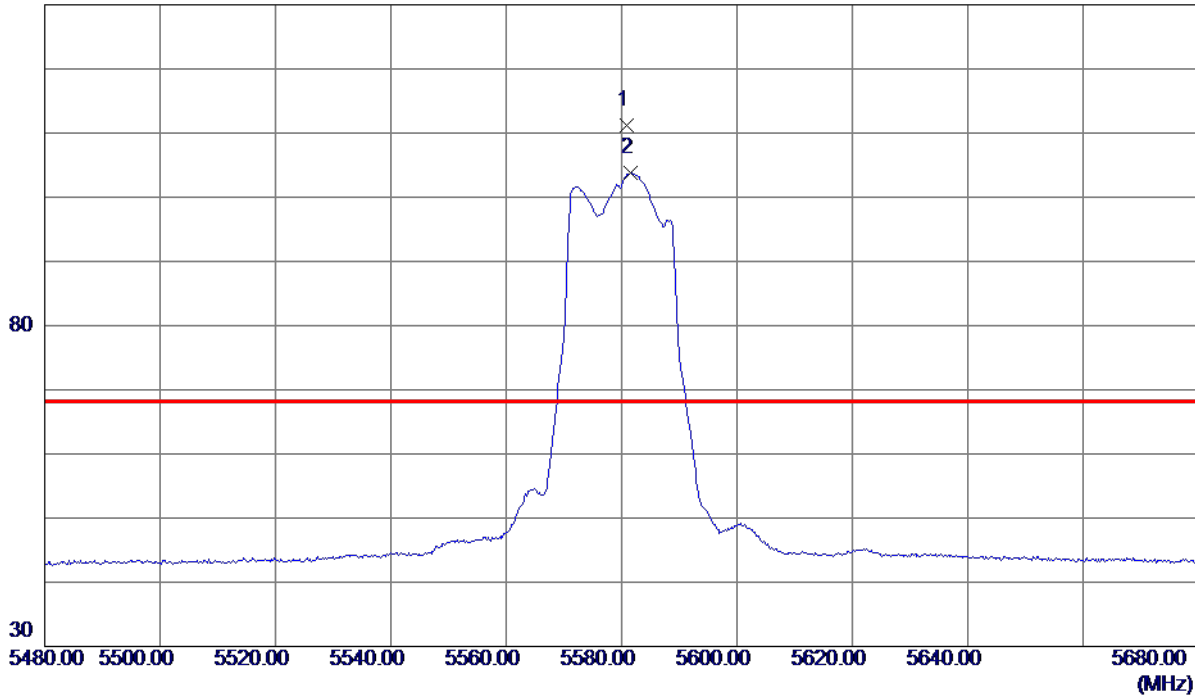

No.	Freq. MHz	Reading Level dBuV/m	Correct Factor dB	Measure ment dBuV/m	Limit dBuV/m	Margin dB	Detector	Comment
1 *	5580.8000	95.85	15.34	111.19	68.30	42.89	Peak	No Limit
2	5581.6000	88.43	15.34	103.77	999.00	-895.23	AVG	No Limit

REMARKS:

- (1) Measurement Value = Reading Level + Correct Factor.
- (2) Margin Level = Measurement Value - Limit Value.

Orthogonal Axis	X
Test Mode	UNII-2C_TX AC (VHT20) Mode 5580 MHz

Vertical

80 dBuV/m

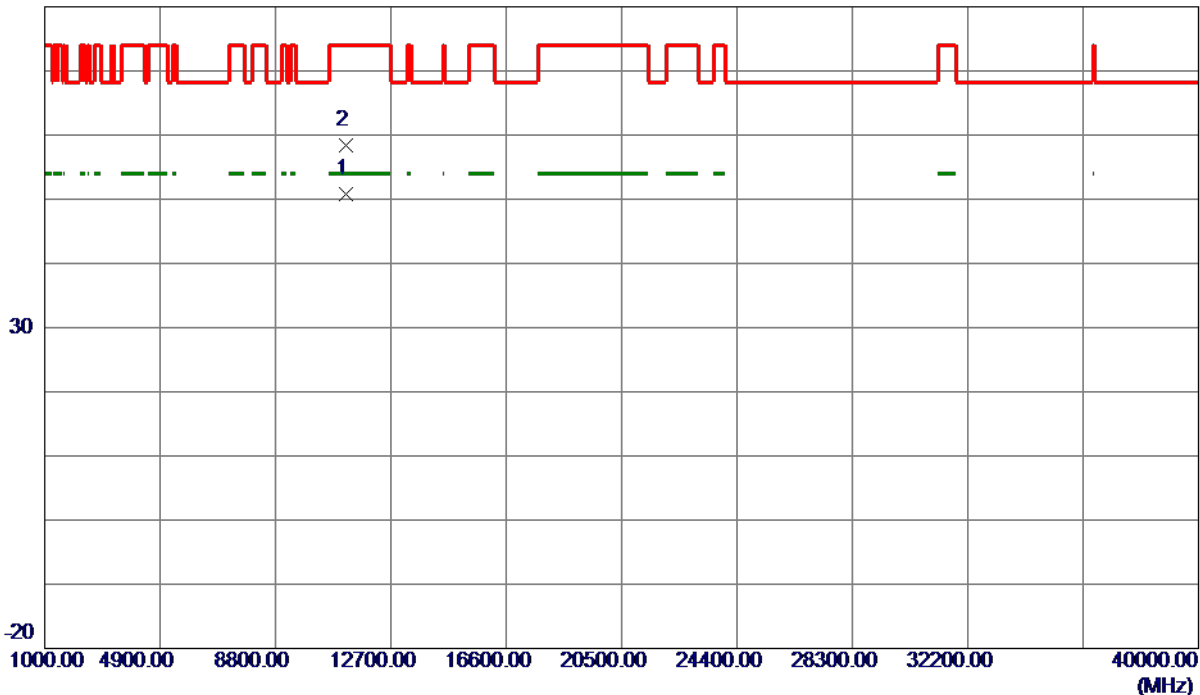

No.	Freq. MHz	Reading Level dBuV/m	Correct Factor dB	Measure ment dBuV/m	Limit dBuV/m	Margin dB	Detector	Comment
1 *	11164.0000	39.01	11.77	50.78	54.00	-3.22	AVG	
2	11164.2000	46.70	11.77	58.47	74.00	-15.53	Peak	

REMARKS:

- (1) Measurement Value = Reading Level + Correct Factor.
- (2) Margin Level = Measurement Value - Limit Value.

Orthogonal Axis	X
Test Mode	UNII-2C_TX AC (VHT20) Mode 5580 MHz

Horizontal

130 dBuV/m

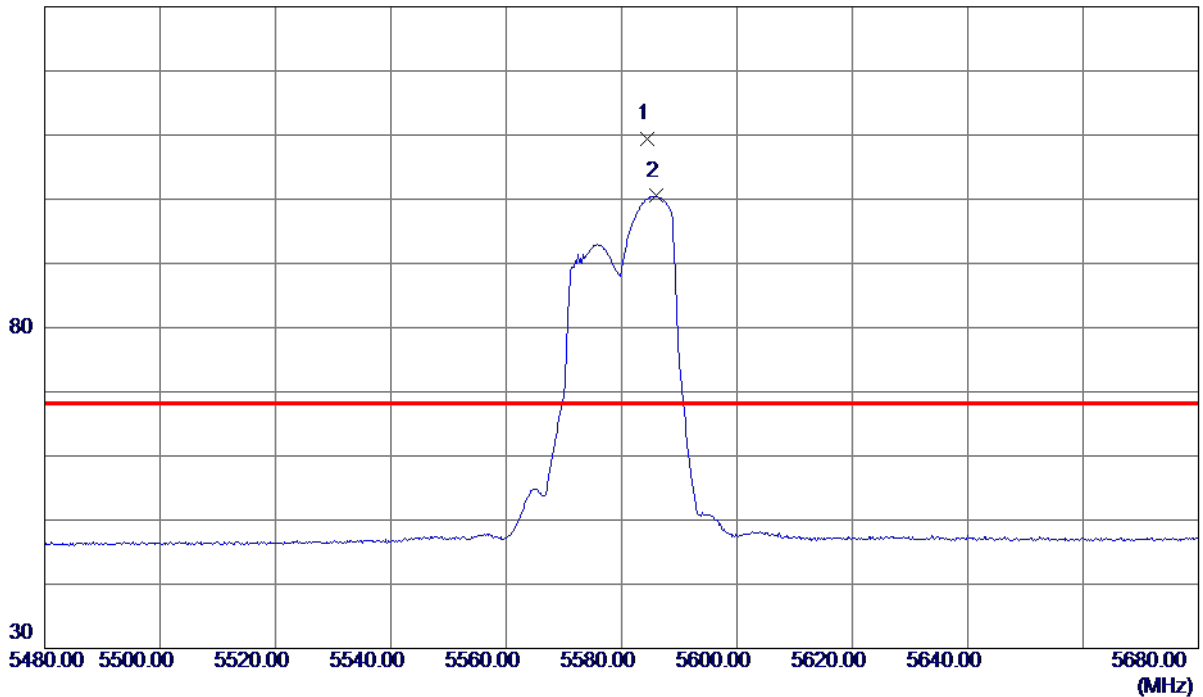

No.	Freq. MHz	Reading Level dBuV/m	Correct Factor dB	Measure ment dBuV/m	Limit dBuV/m	Margin dB	Detector	Comment
1 *	5584.4000	88.60	20.87	109.47	68.30	41.17	Peak	No Limit
2	5586.0000	79.63	20.87	100.50	999.00	-898.50	AVG	No Limit

REMARKS:

- (1) Measurement Value = Reading Level + Correct Factor.
- (2) Margin Level = Measurement Value - Limit Value.

Orthogonal Axis	X
Test Mode	UNII-2C_TX AC (VHT20) Mode 5580 MHz

Horizontal

80 dBuV/m

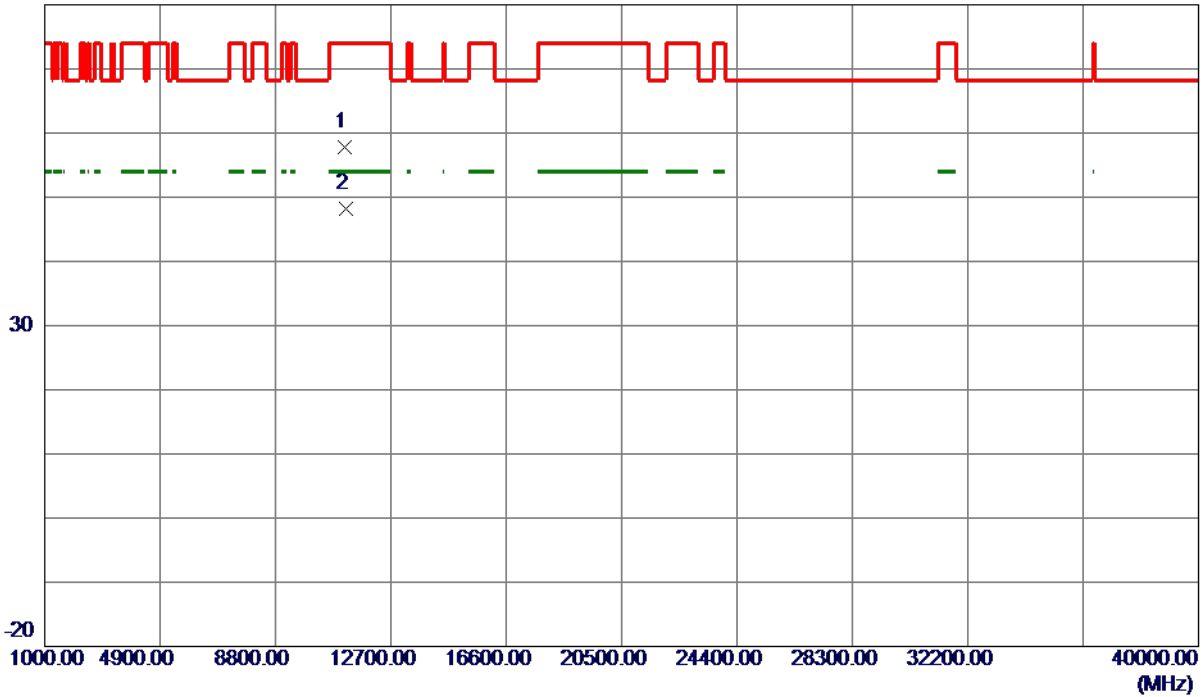

No.	Freq. MHz	Reading Level dBuV/m	Correct Factor dB	Measure ment dBuV/m	Limit dBuV/m	Margin dB	Detector	Comment
1	11160.4000	37.49	20.35	57.84	74.00	-16.16	Peak	
2 *	11163.7500	27.94	20.35	48.29	54.00	-5.71	AVG	

REMARKS:

- (1) Measurement Value = Reading Level + Correct Factor.
- (2) Margin Level = Measurement Value - Limit Value.

Orthogonal Axis	X
Test Mode	UNII-2C_TX AC (VHT20) Mode 5700 MHz

Vertical

130 dBuV/m

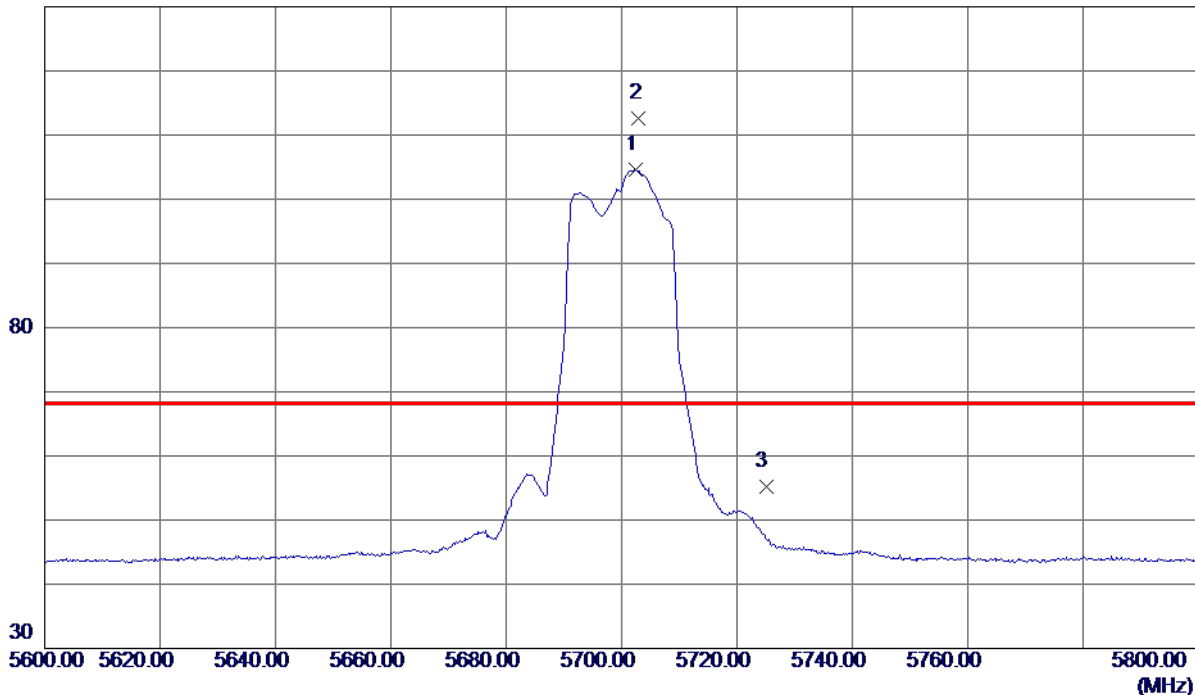

No.	Freq. MHz	Reading Level dBuV/m	Correct Factor dB	Measure ment dBuV/m	Limit dBuV/m	Margin dB	Detector	Comment
1	5702.4000	88.99	15.62	104.61	999.00	-894.39	AVG	No Limit
2 *	5703.0000	97.01	15.63	112.64	68.30	44.34	Peak	No Limit
3	5725.0000	39.59	15.68	55.27	68.30	-13.03	Peak	

REMARKS:

- (1) Measurement Value = Reading Level + Correct Factor.
- (2) Margin Level = Measurement Value - Limit Value.

Orthogonal Axis	X
Test Mode	UNII-2C_TX AC (VHT20) Mode 5700 MHz

Vertical

80 dBuV/m

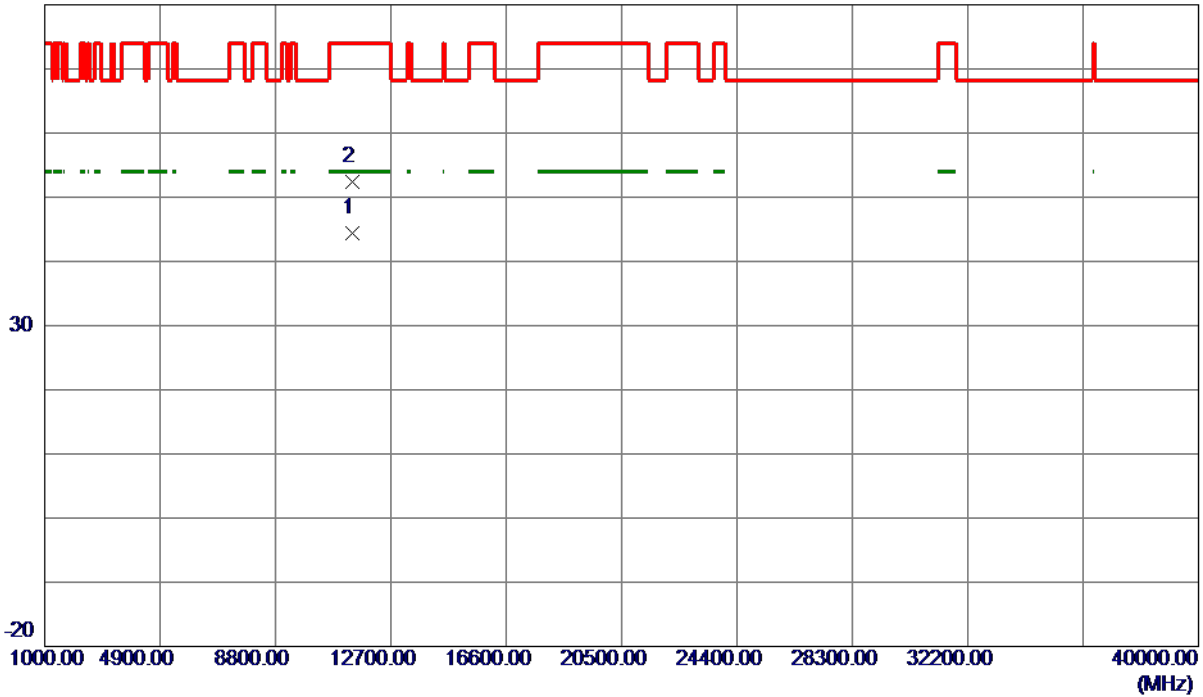

No.	Freq. MHz	Reading Level dBuV/m	Correct Factor dB	Measure ment dBuV/m	Limit dBuV/m	Margin dB	Detector	Comment
1 *	11406.4000	32.41	11.99	44.40	54.00	-9.60	AVG	
2	11407.0000	40.32	11.99	52.31	74.00	-21.69	Peak	

REMARKS:

- (1) Measurement Value = Reading Level + Correct Factor.
- (2) Margin Level = Measurement Value - Limit Value.

Orthogonal Axis	X
Test Mode	UNII-2C_TX AC (VHT20) Mode 5700 MHz

Horizontal

130 dBuV/m

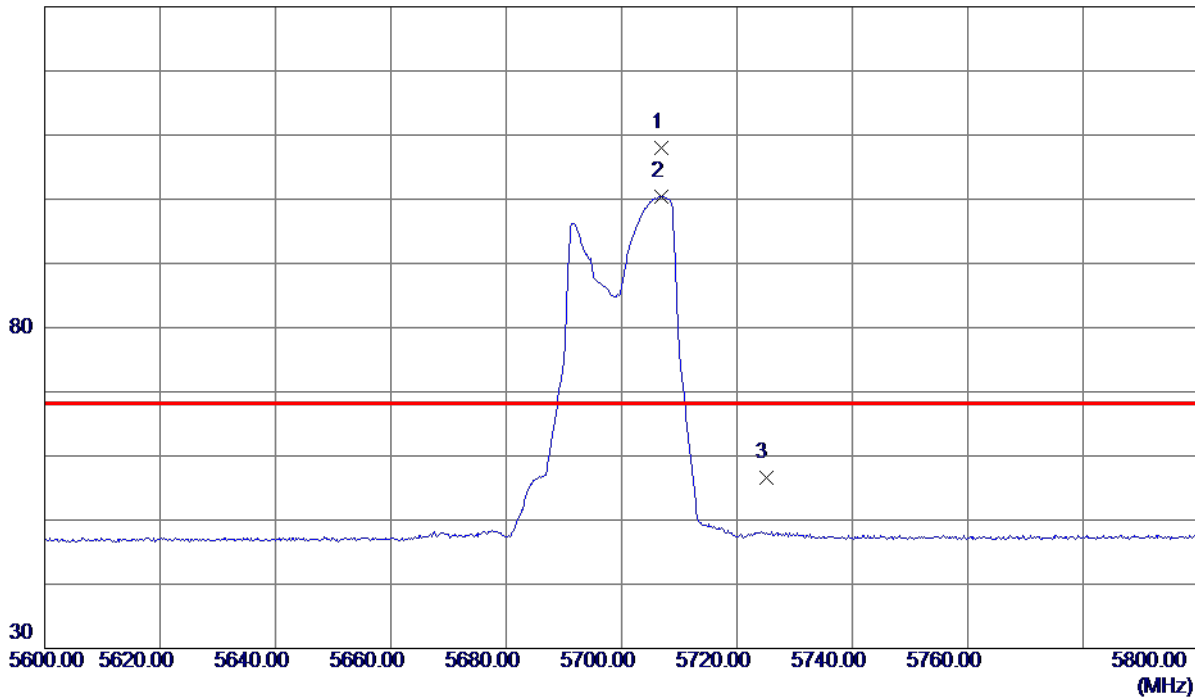

No.	Freq. MHz	Reading Level dBuV/m	Correct Factor dB	Measure ment dBuV/m	Limit dBuV/m	Margin dB	Detector	Comment
1 *	5706.8000	86.59	21.46	108.05	68.30	39.75	Peak	No Limit
2	5706.8000	79.01	21.46	100.47	999.00	-898.53	AVG	No Limit
3	5725.0000	34.97	21.55	56.52	68.30	-11.78	Peak	

REMARKS:

- (1) Measurement Value = Reading Level + Correct Factor.
- (2) Margin Level = Measurement Value - Limit Value.

Orthogonal Axis	X
Test Mode	UNII-2C_TX AC (VHT20) Mode 5700 MHz

Horizontal

80 dBuV/m

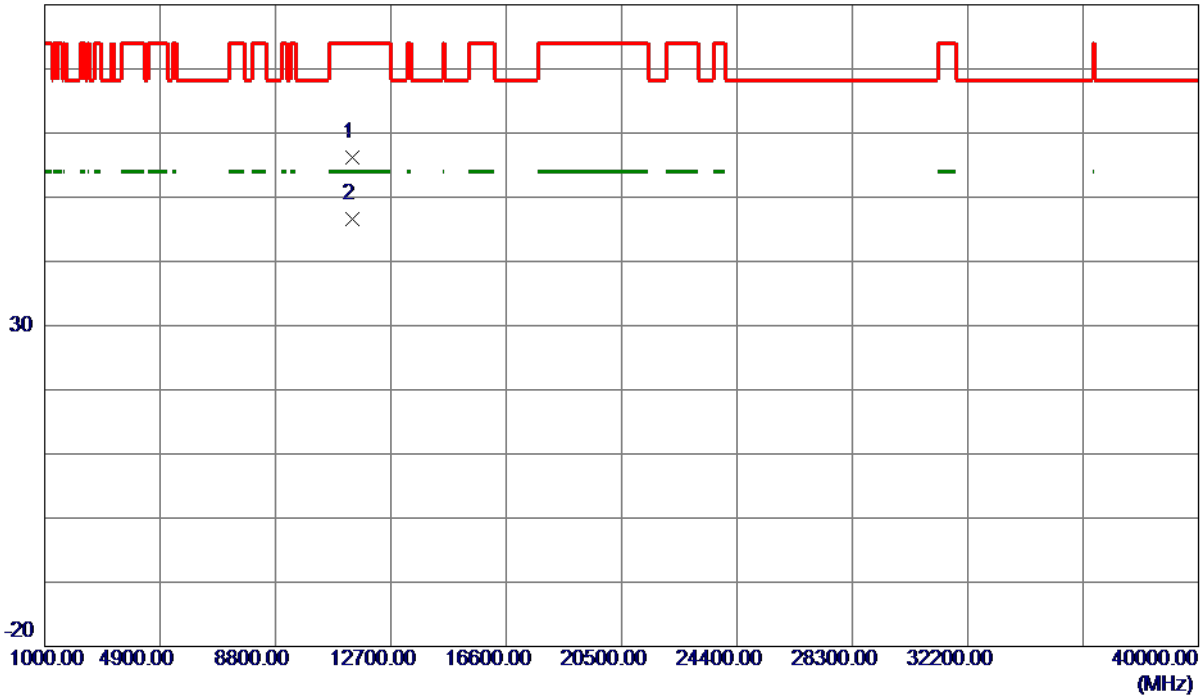

No.	Freq. MHz	Reading Level dBuV/m	Correct Factor dB	Measure ment dBuV/m	Limit dBuV/m	Margin dB	Detector	Comment
1	11397.8500	36.33	19.89	56.22	74.00	-17.78	Peak	
2 *	11399.4000	26.64	19.88	46.52	54.00	-7.48	AVG	

REMARKS:

- (1) Measurement Value = Reading Level + Correct Factor.
- (2) Margin Level = Measurement Value - Limit Value.

Orthogonal Axis	X
Test Mode	UNII-2C_TX AC (VHT40) Mode 5510 MHz

Vertical

130 dBuV/m

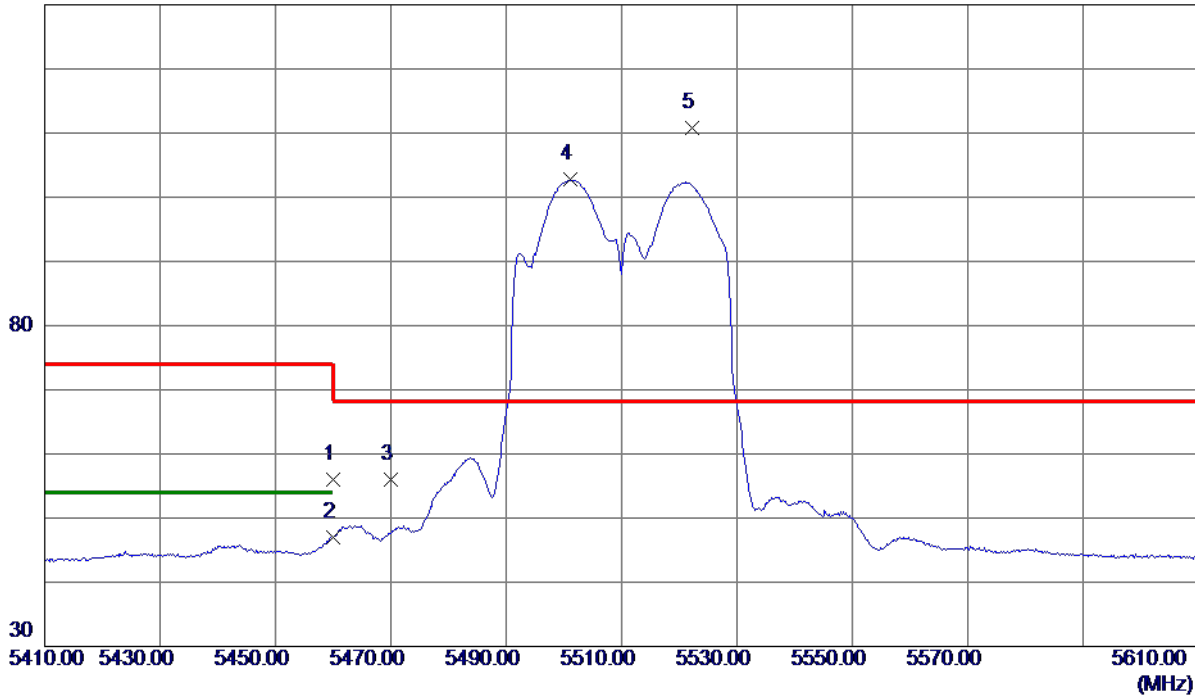

No.	Freq. MHz	Reading Level dBuV/m	Correct Factor dB	Measure ment dBuV/m	Limit dBuV/m	Margin dB	Detector	Comment
1	5460.0000	40.94	15.05	55.99	74.00	-18.01	Peak	
2	5460.0000	31.86	15.05	46.91	54.00	-7.09	AVG	
3	5470.0000	40.91	15.07	55.98	68.30	-12.32	Peak	
4	5501.2000	87.70	15.15	102.85	999.00	-896.15	AVG	No Limit
5 *	5522.2000	95.51	15.20	110.71	68.30	42.41	Peak	No Limit

REMARKS:

- (1) Measurement Value = Reading Level + Correct Factor.
- (2) Margin Level = Measurement Value - Limit Value.

Orthogonal Axis	X
Test Mode	UNII-2C_TX AC (VHT40) Mode 5510 MHz

Vertical

80 dBuV/m

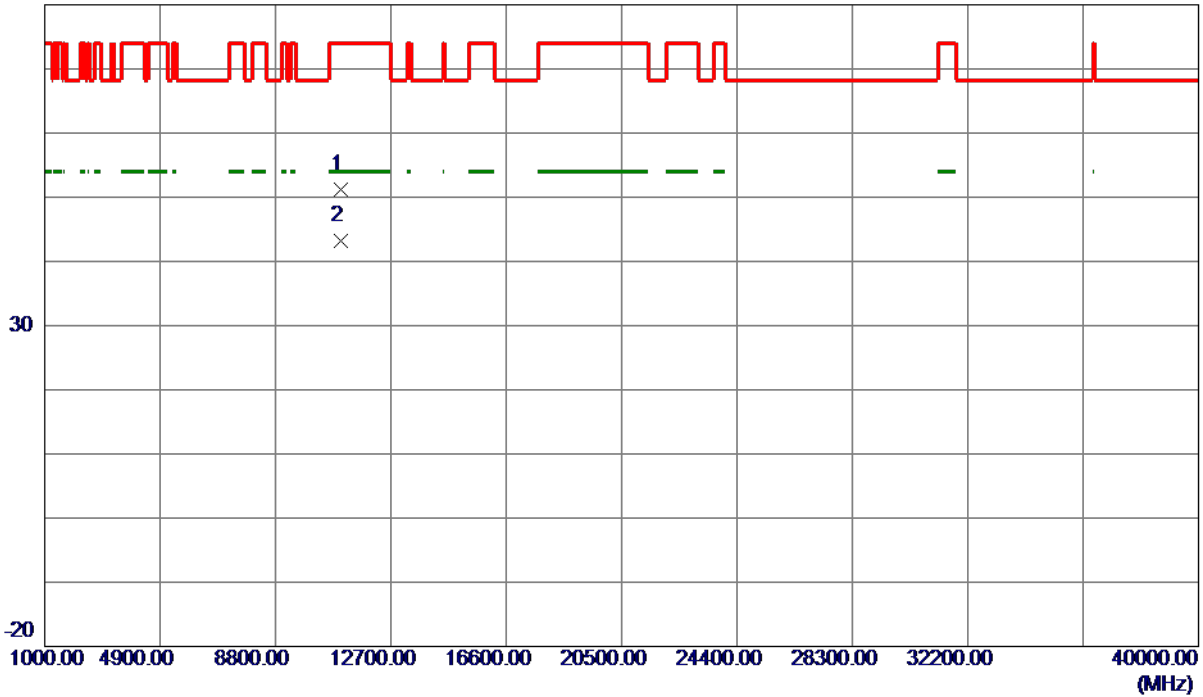

No.	Freq. MHz	Reading Level dBuV/m	Correct Factor dB	Measure ment dBuV/m	Limit dBuV/m	Margin dB	Detector	Comment
1	11021.2000	39.61	11.64	51.25	74.00	-22.75	Peak	
2 *	11022.0000	31.49	11.64	43.13	54.00	-10.87	AVG	

REMARKS:

- (1) Measurement Value = Reading Level + Correct Factor.
- (2) Margin Level = Measurement Value - Limit Value.

Orthogonal Axis	X
Test Mode	UNII-2C_TX AC (VHT40) Mode 5510 MHz

Horizontal

130 dBuV/m

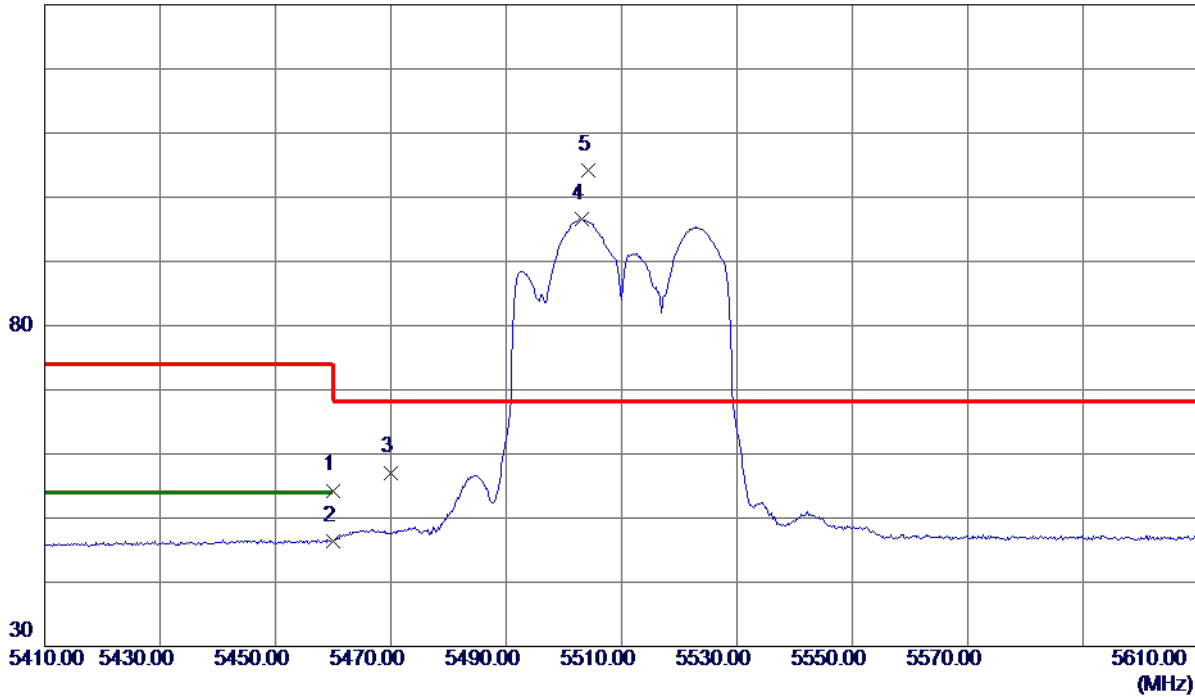

No.	Freq. MHz	Reading Level dBuV/m	Correct Factor dB	Measure ment dBuV/m	Limit dBuV/m	Margin dB	Detector	Comment
1	5460.0000	33.99	20.31	54.30	74.00	-19.70	Peak	
2	5460.0000	26.06	20.31	46.37	54.00	-7.63	AVG	
3	5470.0000	36.75	20.35	57.10	68.30	-11.20	Peak	
4	5503.2000	76.10	20.47	96.57	999.00	-902.43	AVG	No Limit
5 *	5504.2000	83.64	20.48	104.12	68.30	35.82	Peak	No Limit

REMARKS:

- (1) Measurement Value = Reading Level + Correct Factor.
- (2) Margin Level = Measurement Value - Limit Value.

Orthogonal Axis	X
Test Mode	UNII-2C_TX AC (VHT40) Mode 5510 MHz

Horizontal

80 dBuV/m

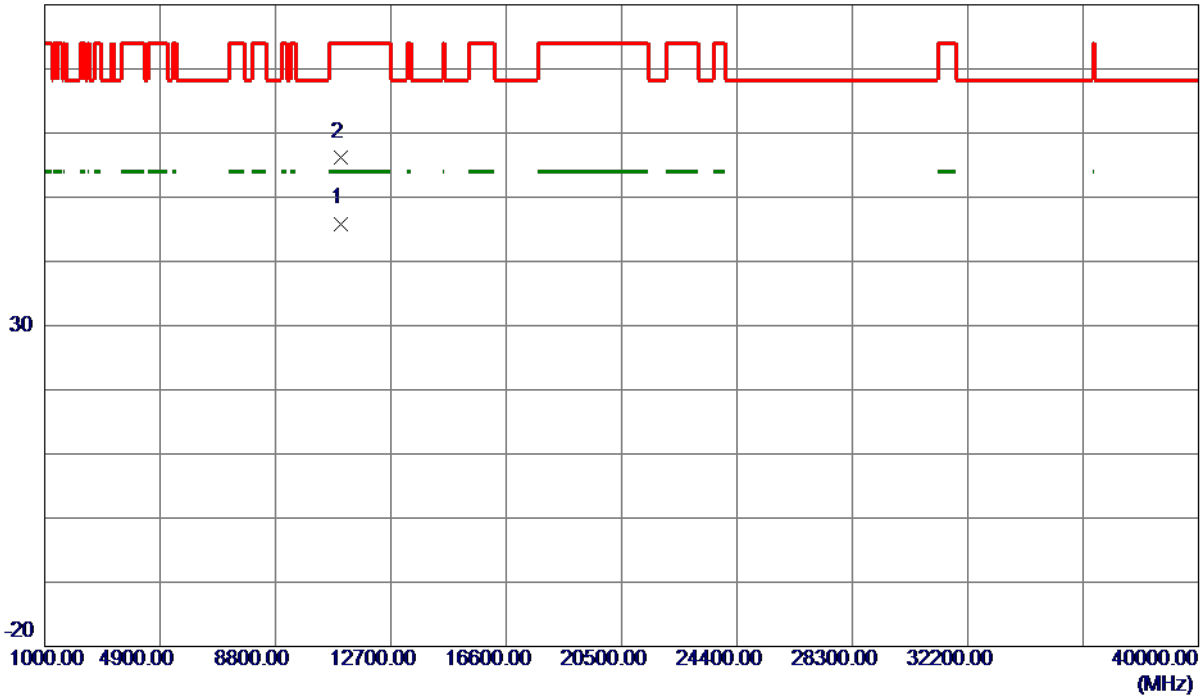

No.	Freq. MHz	Reading Level dBuV/m	Correct Factor dB	Measure ment dBuV/m	Limit dBuV/m	Margin dB	Detector	Comment
1 *	11025.3000	25.28	20.62	45.90	54.00	-8.10	AVG	
2	11025.3500	35.64	20.62	56.26	74.00	-17.74	Peak	

REMARKS:

- (1) Measurement Value = Reading Level + Correct Factor.
- (2) Margin Level = Measurement Value - Limit Value.

Orthogonal Axis	X
Test Mode	UNII-2C_TX AC (VHT40) Mode 5550 MHz

Vertical

130 dBuV/m

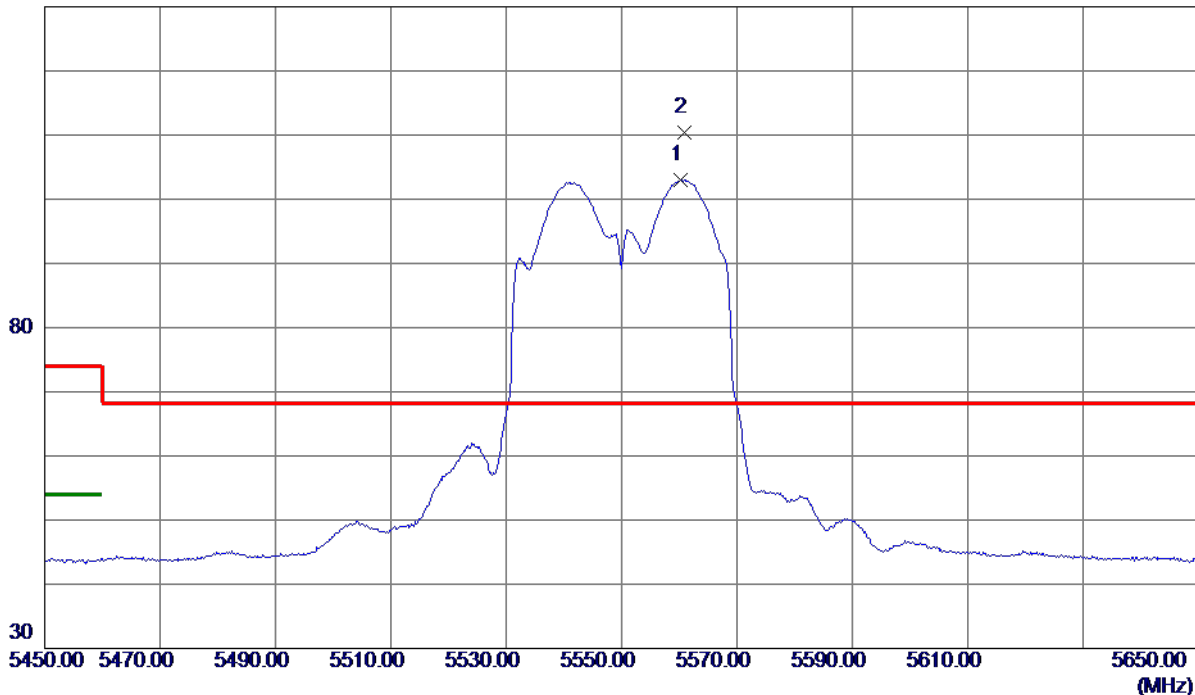

No.	Freq. MHz	Reading Level dBuV/m	Correct Factor dB	Measure ment dBuV/m	Limit dBuV/m	Margin dB	Detector	Comment
1	5560.2000	87.65	15.29	102.94	999.00	-896.06	AVG	No Limit
2 *	5560.8000	95.17	15.29	110.46	68.30	42.16	Peak	No Limit

REMARKS:

- (1) Measurement Value = Reading Level + Correct Factor.
- (2) Margin Level = Measurement Value - Limit Value.

Orthogonal Axis	X
Test Mode	UNII-2C_TX AC (VHT40) Mode 5550 MHz

Vertical

80 dBuV/m

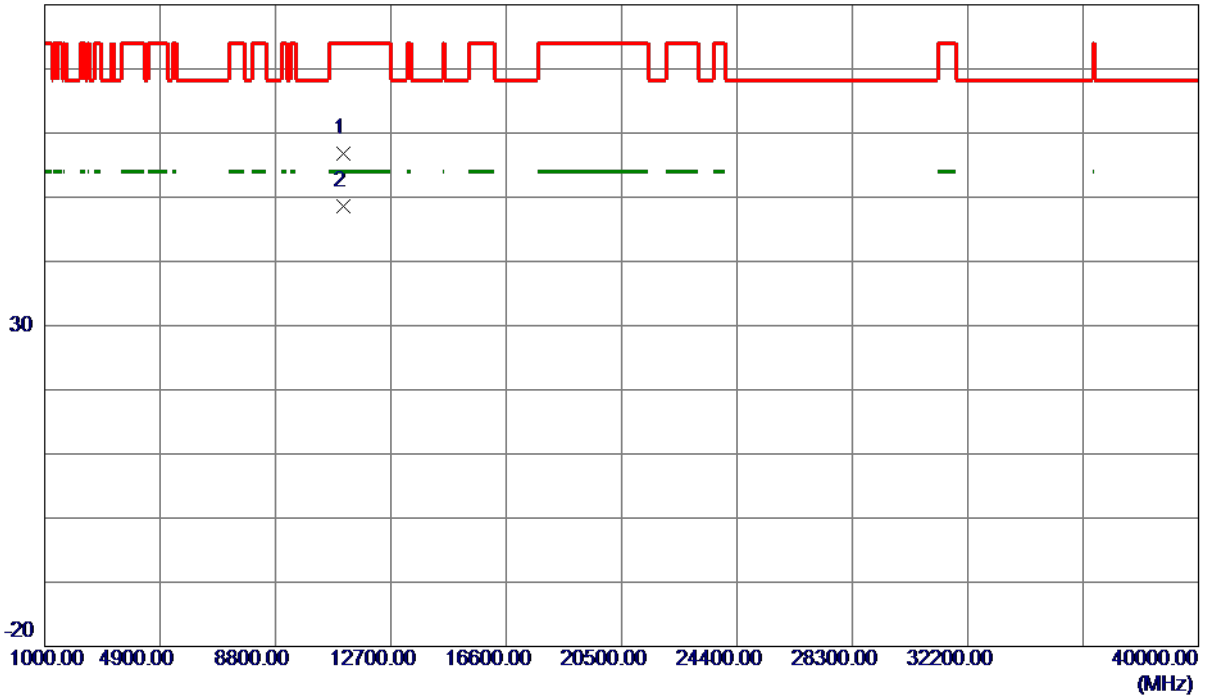

No.	Freq. MHz	Reading Level dBuV/m	Correct Factor dB	Measure ment dBuV/m	Limit dBuV/m	Margin dB	Detector	Comment
1	11102.2000	45.04	11.71	56.75	74.00	-17.25	Peak	
2 *	11104.8000	36.95	11.72	48.67	54.00	-5.33	AVG	

REMARKS:

- (1) Measurement Value = Reading Level + Correct Factor.
- (2) Margin Level = Measurement Value - Limit Value.

Orthogonal Axis	X
Test Mode	UNII-2C_TX AC (VHT40) Mode 5550 MHz

Horizontal

130 dBuV/m

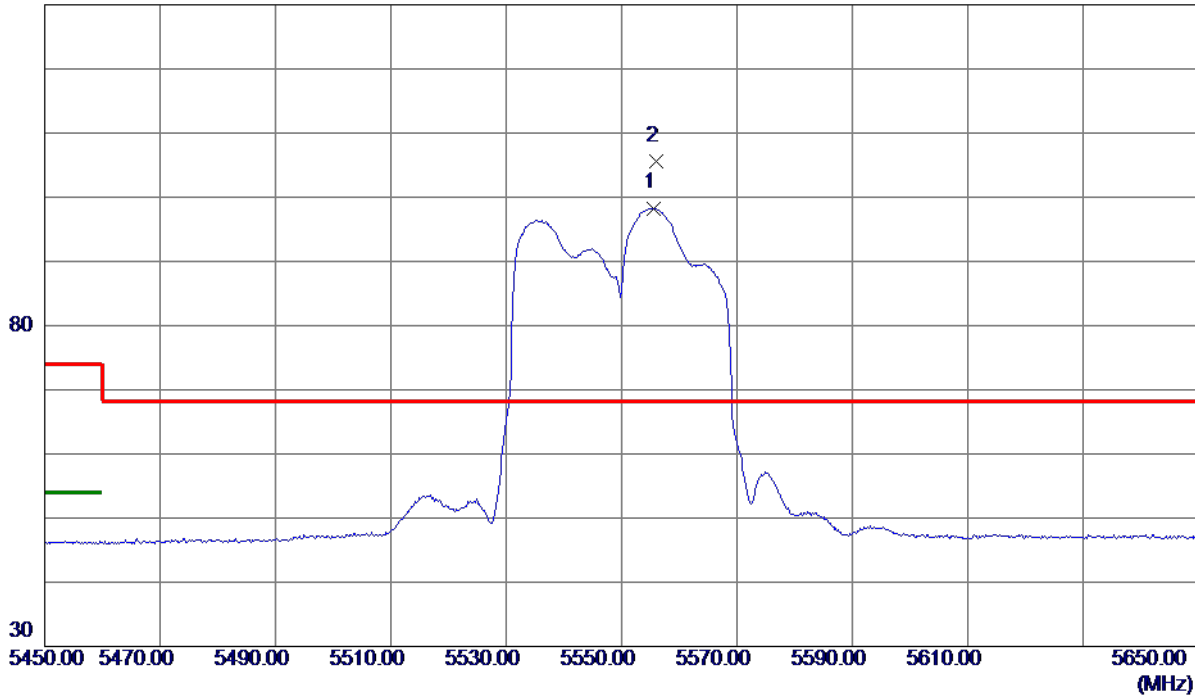

No.	Freq. MHz	Reading Level dBuV/m	Correct Factor dB	Measure ment dBuV/m	Limit dBuV/m	Margin dB	Detector	Comment
1	5555.6000	77.57	20.73	98.30	999.00	-900.70	AVG	No Limit
2 *	5556.0000	84.85	20.73	105.58	68.30	37.28	Peak	No Limit

REMARKS:

- (1) Measurement Value = Reading Level + Correct Factor.
- (2) Margin Level = Measurement Value - Limit Value.

Orthogonal Axis	X
Test Mode	UNII-2C_TX AC (VHT40) Mode 5550 MHz

Horizontal

80 dBuV/m

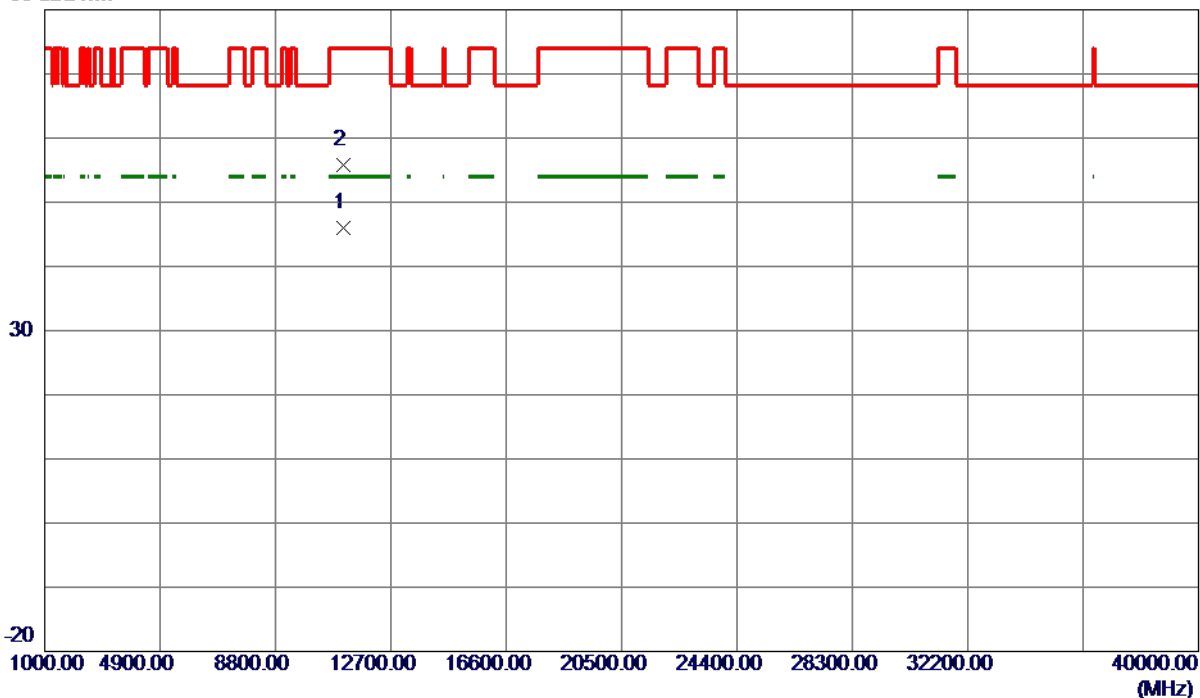

No.	Freq. MHz	Reading Level dBuV/m	Correct Factor dB	Measure ment dBuV/m	Limit dBuV/m	Margin dB	Detector	Comment
1 *	11099.8500	25.49	20.47	45.96	54.00	-8.04	AVG	
2	11103.3500	35.26	20.47	55.73	74.00	-18.27	Peak	

REMARKS:

- (1) Measurement Value = Reading Level + Correct Factor.
- (2) Margin Level = Measurement Value - Limit Value.

Orthogonal Axis	X
Test Mode	UNII-2C_TX AC (VHT40) Mode 5670 MHz

Vertical

130 dBuV/m

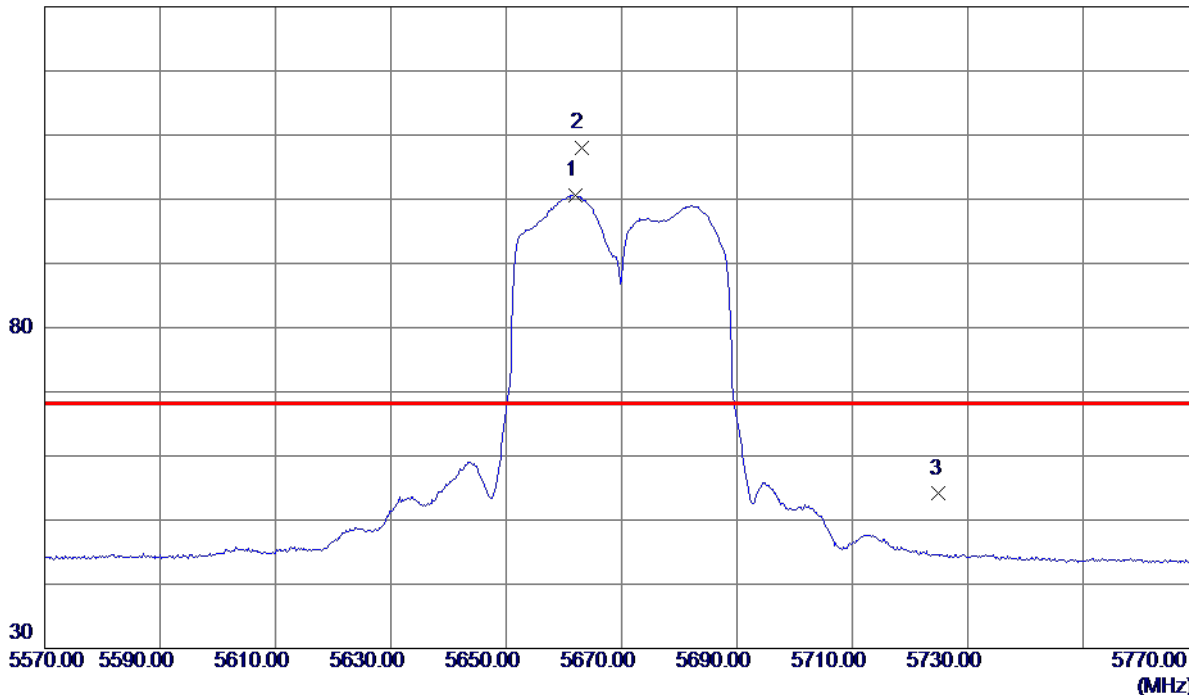

No.	Freq. MHz	Reading Level dBuV/m	Correct Factor dB	Measure ment dBuV/m	Limit dBuV/m	Margin dB	Detector	Comment
1	5662.0000	85.10	15.53	100.63	999.00	-898.37	AVG	No Limit
2 *	5663.0000	92.44	15.53	107.97	68.30	39.67	Peak	No Limit
3	5725.0000	38.42	15.68	54.10	68.30	-14.20	Peak	

REMARKS:

- (1) Measurement Value = Reading Level + Correct Factor.
- (2) Margin Level = Measurement Value - Limit Value.

Orthogonal Axis	X
Test Mode	UNII-2C_TX AC (VHT40) Mode 5670 MHz

Vertical

80 dBuV/m

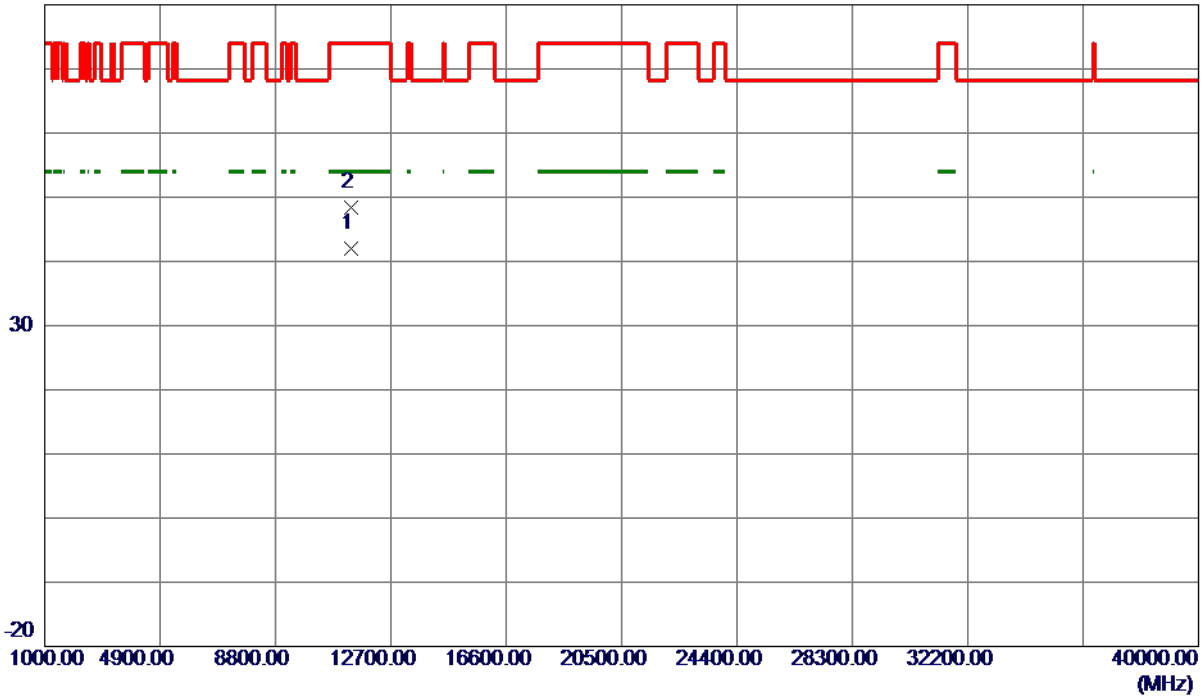

No.	Freq. MHz	Reading Level dBuV/m	Correct Factor dB	Measure ment dBuV/m	Limit dBuV/m	Margin dB	Detector	Comment
1 *	11345.0000	30.16	11.93	42.09	54.00	-11.91	AVG	
2	11346.8000	36.52	11.94	48.46	74.00	-25.54	Peak	

REMARKS:

- (1) Measurement Value = Reading Level + Correct Factor.
- (2) Margin Level = Measurement Value - Limit Value.

Orthogonal Axis	X
Test Mode	UNII-2C_TX AC (VHT40) Mode 5670 MHz

Horizontal

130 dBuV/m

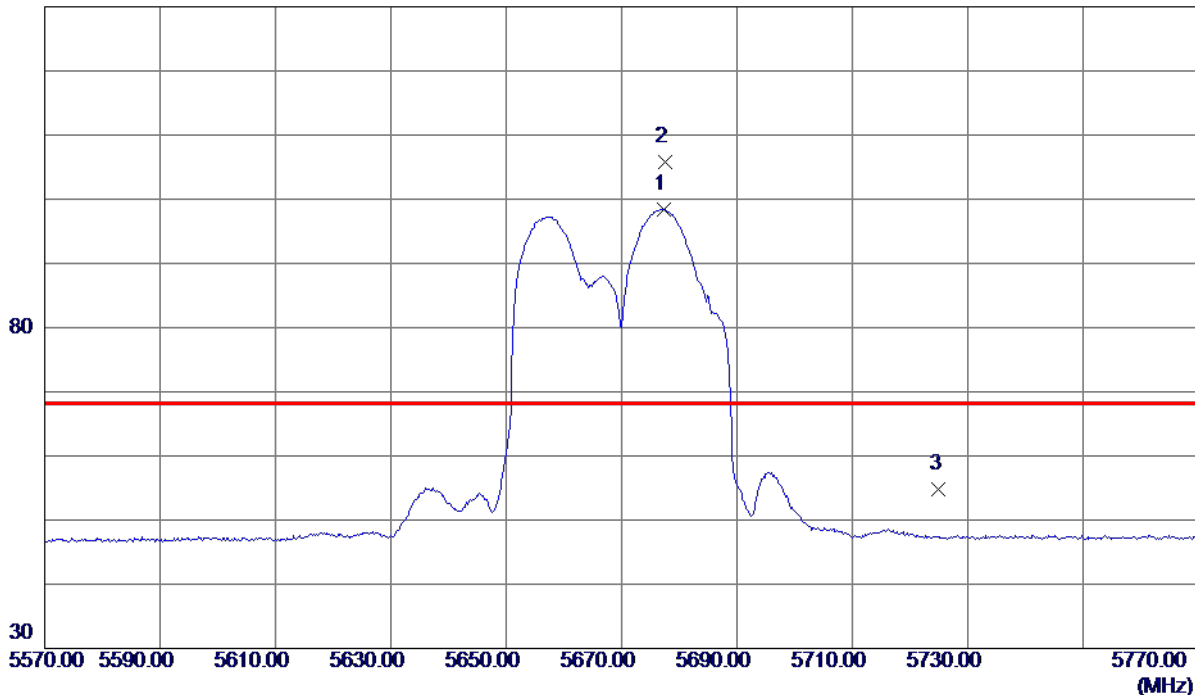

No.	Freq. MHz	Reading Level dBuV/m	Correct Factor dB	Measure ment dBuV/m	Limit dBuV/m	Margin dB	Detector	Comment
1	5677.4000	77.04	21.32	98.36	999.00	-900.64	AVG	No Limit
2 *	5677.6000	84.49	21.32	105.81	68.30	37.51	Peak	No Limit
3	5725.0000	33.19	21.55	54.74	68.30	-13.56	Peak	

REMARKS:

- (1) Measurement Value = Reading Level + Correct Factor.
- (2) Margin Level = Measurement Value - Limit Value.

Orthogonal Axis	X
Test Mode	UNII-2C_TX AC (VHT40) Mode 5670 MHz

Horizontal

80 dBuV/m

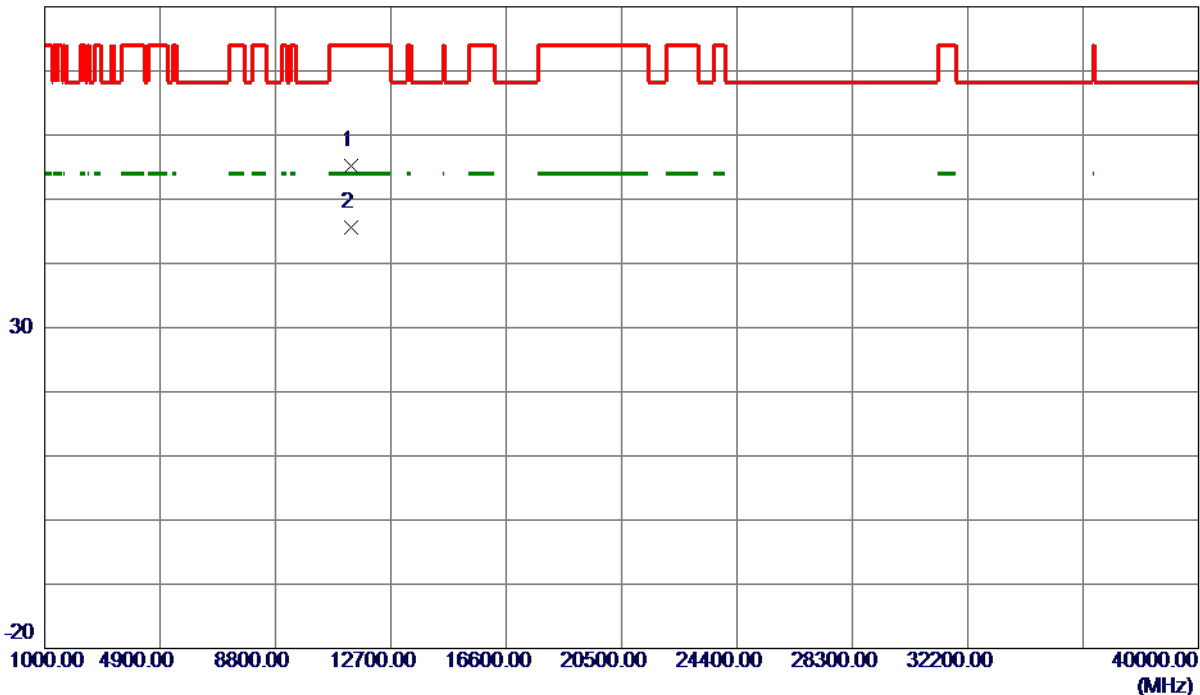

No.	Freq. MHz	Reading Level dBuV/m	Correct Factor dB	Measure ment dBuV/m	Limit dBuV/m	Margin dB	Detector	Comment
1	11339.7000	35.24	20.00	55.24	74.00	-18.76	Peak	
2 *	11341.3500	25.58	20.00	45.58	54.00	-8.42	AVG	

REMARKS:

- (1) Measurement Value = Reading Level + Correct Factor.
- (2) Margin Level = Measurement Value - Limit Value.

Orthogonal Axis	X
Test Mode	UNII-2C_TX AC (VHT80) Mode 5530 MHz

Vertical

130 dBuV/m

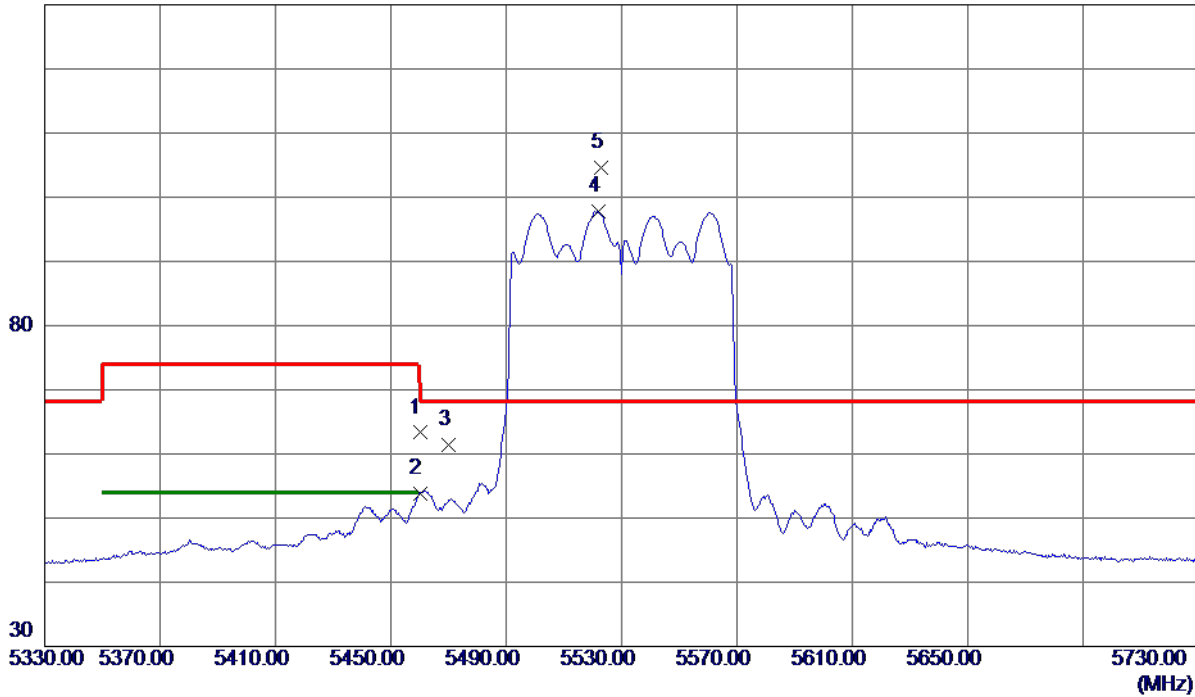

No.	Freq. MHz	Reading Level dBuV/m	Correct Factor dB	Measure ment dBuV/m	Limit dBuV/m	Margin dB	Detector	Comment
1	5460.0000	48.25	15.05	63.30	74.00	-10.70	Peak	
2	5460.0000	38.82	15.05	53.87	54.00	-0.13	AVG	
3	5470.0000	46.26	15.07	61.33	68.30	-6.97	Peak	
4	5522.0000	82.62	15.20	97.82	999.00	-901.18	AVG	No Limit
5 *	5522.8000	89.33	15.20	104.53	68.30	36.23	Peak	No Limit

REMARKS:

- (1) Measurement Value = Reading Level + Correct Factor.
- (2) Margin Level = Measurement Value - Limit Value.

Orthogonal Axis	X
Test Mode	UNII-2C_TX AC (VHT80) Mode 5530 MHz

Vertical

80 dBuV/m

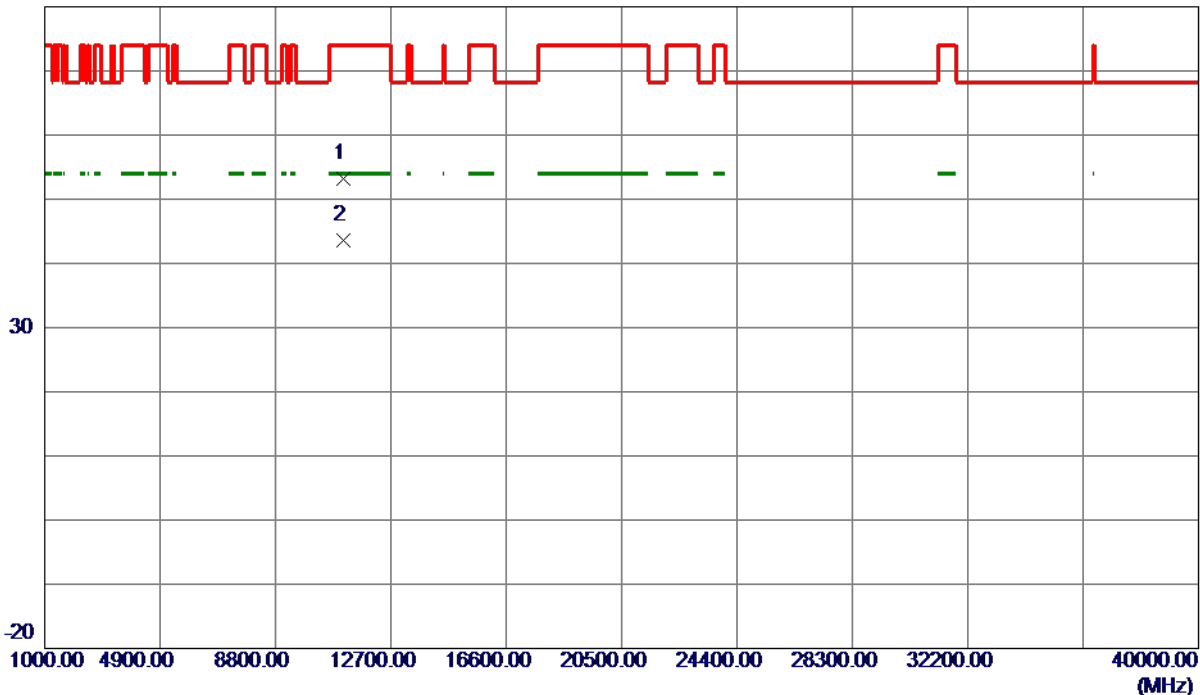

No.	Freq. MHz	Reading Level dBuV/m	Correct Factor dB	Measure ment dBuV/m	Limit dBuV/m	Margin dB	Detector	Comment
1	11083.0000	41.52	11.70	53.22	74.00	-20.78	Peak	
2 *	11083.4000	31.96	11.70	43.66	54.00	-10.34	AVG	

REMARKS:

- (1) Measurement Value = Reading Level + Correct Factor.
- (2) Margin Level = Measurement Value - Limit Value.

Orthogonal Axis	X
Test Mode	UNII-2C_TX AC (VHT80) Mode 5530 MHz

Horizontal

130 dBuV/m

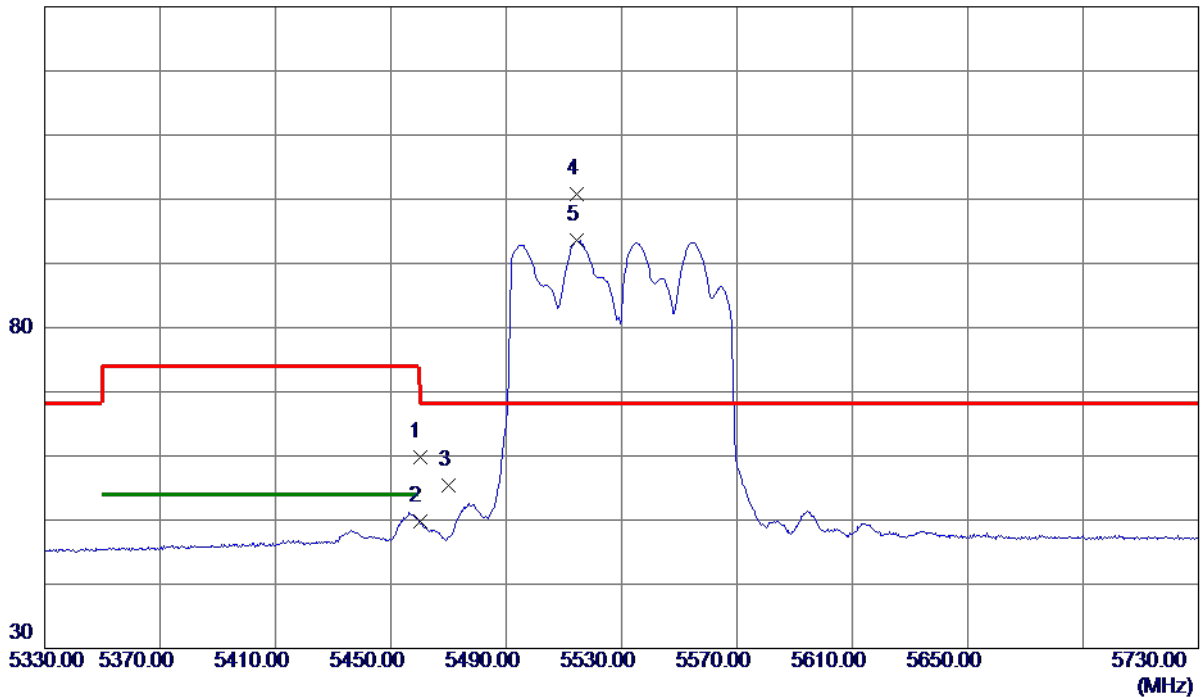

No.	Freq. MHz	Reading Level dBuV/m	Correct Factor dB	Measure ment dBuV/m	Limit dBuV/m	Margin dB	Detector	Comment
1	5460.0000	39.51	20.31	59.82	74.00	-14.18	Peak	
2	5460.0000	29.41	20.31	49.72	54.00	-4.28	AVG	
3	5470.0000	35.04	20.35	55.39	68.30	-12.91	Peak	
4 *	5514.4000	80.18	20.53	100.71	68.30	32.41	Peak	No Limit
5	5514.4000	73.03	20.53	93.56	999.00	-905.44	AVG	No Limit

REMARKS:

- (1) Measurement Value = Reading Level + Correct Factor.
- (2) Margin Level = Measurement Value - Limit Value.

Orthogonal Axis	X
Test Mode	UNII-2C_TX AC (VHT80) Mode 5530 MHz

Horizontal

80 dBuV/m

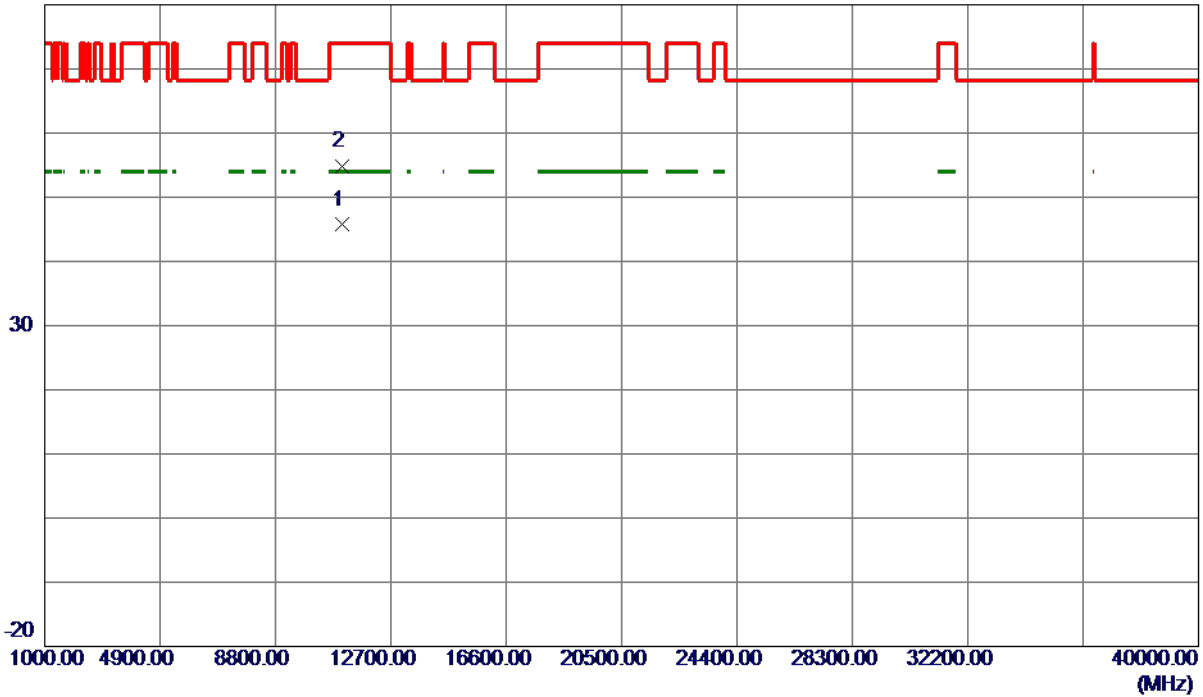

No.	Freq. MHz	Reading Level dBuV/m	Correct Factor dB	Measure ment dBuV/m	Limit dBuV/m	Margin dB	Detector	Comment
1 *	11064.0000	25.16	20.54	45.70	54.00	-8.30	AVG	
2	11064.1500	34.20	20.54	54.74	74.00	-19.26	Peak	

REMARKS:

- (1) Measurement Value = Reading Level + Correct Factor.
- (2) Margin Level = Measurement Value - Limit Value.

Orthogonal Axis	X
Test Mode	UNII-2C_TX AC (VHT80) Mode 5610 MHz

Vertical

130 dBuV/m



No.	Freq. MHz	Reading Level dBuV/m	Correct Factor dB	Measure ment dBuV/m	Limit dBuV/m	Margin dB	Detector	Comment
1 *	5581.2000	91.00	15.34	106.34	68.30	38.04	Peak	No Limit
2	5582.0000	83.85	15.34	99.19	999.00	-899.81	AVG	No Limit
3	5725.0000	40.48	15.68	56.16	68.30	-12.14	Peak	

REMARKS:

- (1) Measurement Value = Reading Level + Correct Factor.
- (2) Margin Level = Measurement Value - Limit Value.

Orthogonal Axis	X
Test Mode	UNII-2C_TX AC (VHT80) Mode 5610 MHz

Vertical

80 dBuV/m

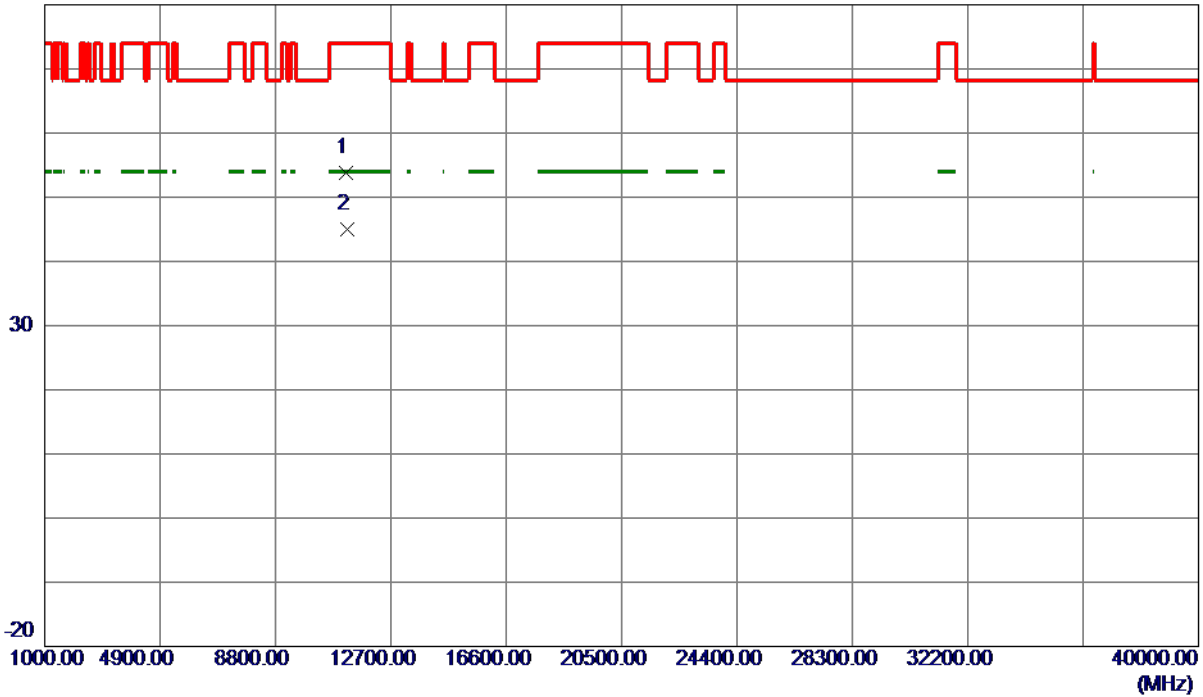

No.	Freq. MHz	Reading Level dBuV/m	Correct Factor dB	Measure ment dBuV/m	Limit dBuV/m	Margin dB	Detector	Comment
1	11204.2000	41.96	11.81	53.77	74.00	-20.23	Peak	
2 *	11205.8000	33.23	11.81	45.04	54.00	-8.96	AVG	

REMARKS:

- (1) Measurement Value = Reading Level + Correct Factor.
- (2) Margin Level = Measurement Value - Limit Value.

Orthogonal Axis	X
Test Mode	UNII-2C_TX AC (VHT80) Mode 5610 MHz

Horizontal

130 dBuV/m

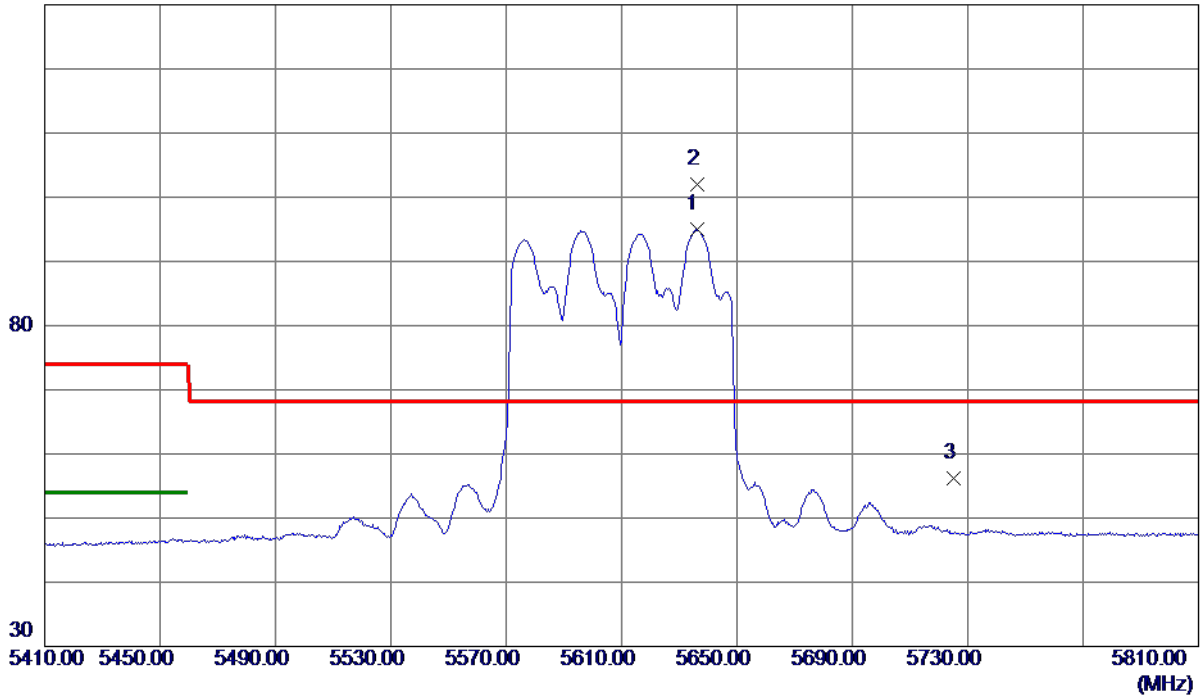

No.	Freq. MHz	Reading Level dBuV/m	Correct Factor dB	Measure ment dBuV/m	Limit dBuV/m	Margin dB	Detector	Comment
1	5636.0000	73.79	21.12	94.91	999.00	-904.09	AVG	No Limit
2 *	5636.4000	80.87	21.12	101.99	68.30	33.69	Peak	No Limit
3	5725.0000	34.65	21.55	56.20	68.30	-12.10	Peak	

REMARKS:

- (1) Measurement Value = Reading Level + Correct Factor.
- (2) Margin Level = Measurement Value - Limit Value.

Orthogonal Axis	X
Test Mode	UNII-2C_TX AC (VHT80) Mode 5610 MHz

Horizontal

80 dBuV/m



No.	Freq. MHz	Reading Level dBuV/m	Correct Factor dB	Measure ment dBuV/m	Limit dBuV/m	Margin dB	Detector	Comment
1 *	11218.8000	26.37	11.82	38.19	54.00	-15.81	AVG	
2	11219.8000	36.12	11.82	47.94	74.00	-26.06	Peak	

REMARKS:

- (1) Measurement Value = Reading Level + Correct Factor.
- (2) Margin Level = Measurement Value - Limit Value.

Orthogonal Axis	X
Test Mode	UNII-3_TX AC (VHT20) Mode 5745 MHz

Vertical

130 dBuV/m

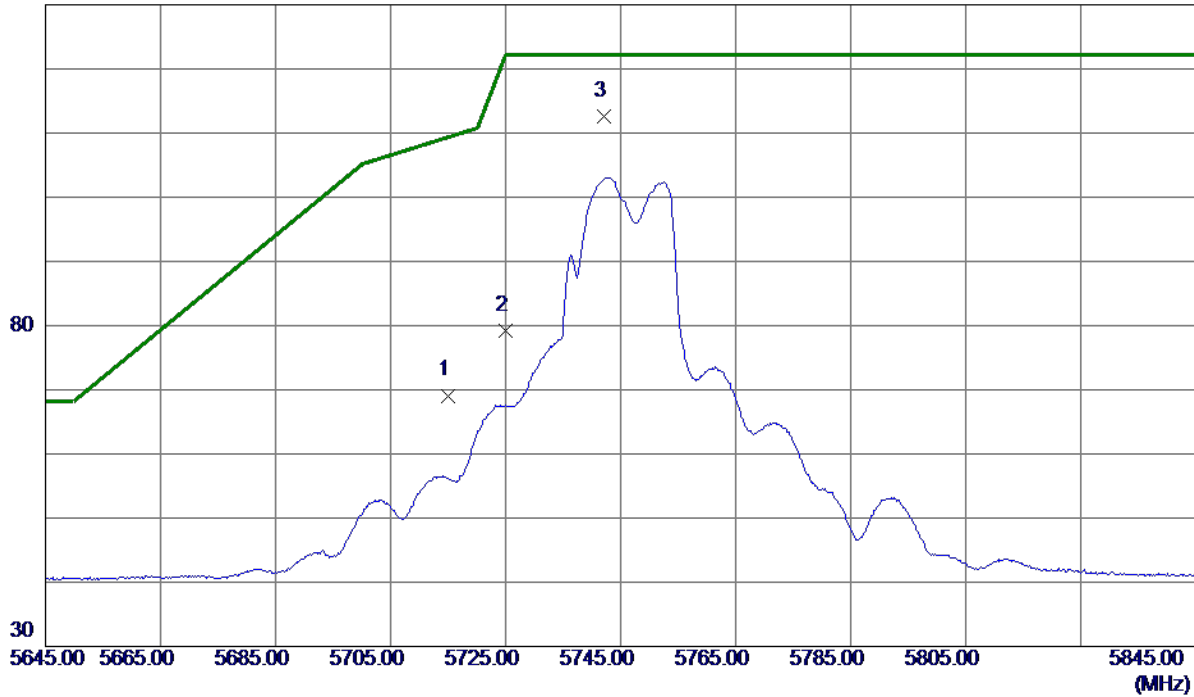

No.	Freq. MHz	Reading Level dBuV/m	Correct Factor dB	Measure ment dBuV/m	Limit dBuV/m	Margin dB	Detector	Comment
1	5715.0000	53.11	15.99	69.10	109.40	-40.30	Peak	
2	5725.0000	63.21	16.00	79.21	122.20	-42.99	Peak	
3 *	5742.2000	96.51	16.01	112.52	122.20	-9.68	Peak	No Limit

REMARKS:

- (1) Measurement Value = Reading Level + Correct Factor.
- (2) Margin Level = Measurement Value - Limit Value.

Orthogonal Axis	X
Test Mode	UNII-3_TX AC (VHT20) Mode 5745 MHz

Vertical

80 dBuV/m

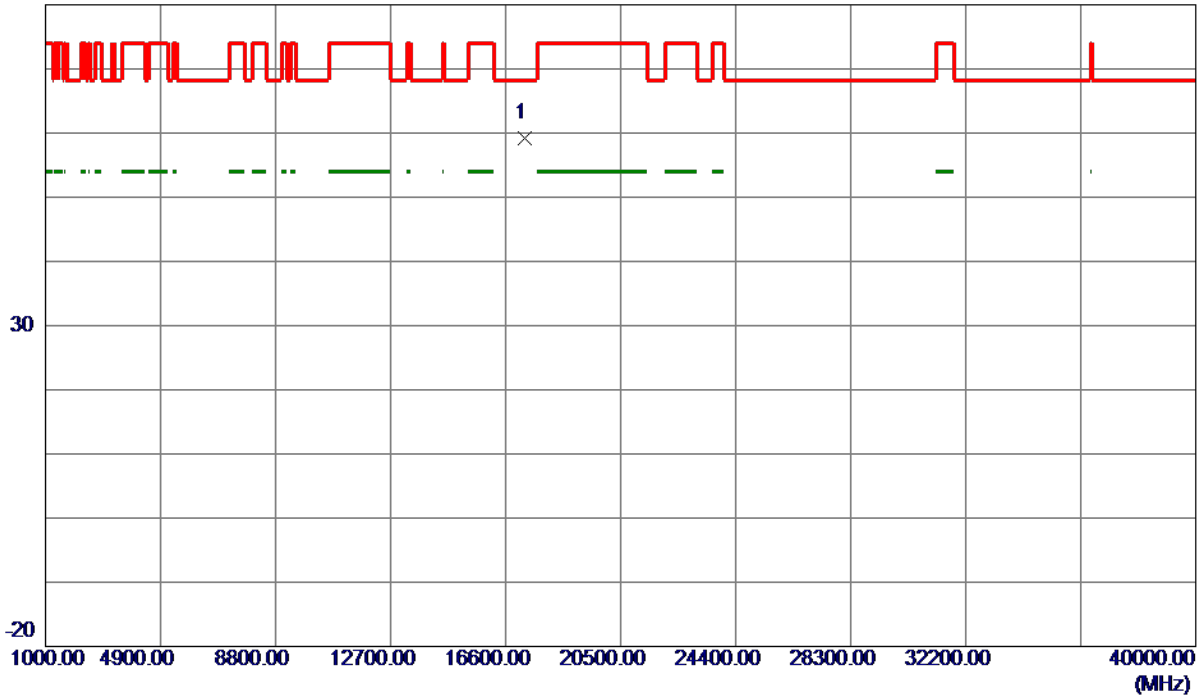

No.	Freq. MHz	Reading Level dBuV/m	Correct Factor dB	Measure ment dBuV/m	Limit dBuV/m	Margin dB	Detector	Comment
1 *	17235.7200	40.25	18.95	59.20	68.30	-9.10	Peak	

REMARKS:

- (1) Measurement Value = Reading Level + Correct Factor.
- (2) Margin Level = Measurement Value - Limit Value.

Orthogonal Axis	X
Test Mode	UNII-3_TX AC (VHT20) Mode 5745 MHz

Horizontal

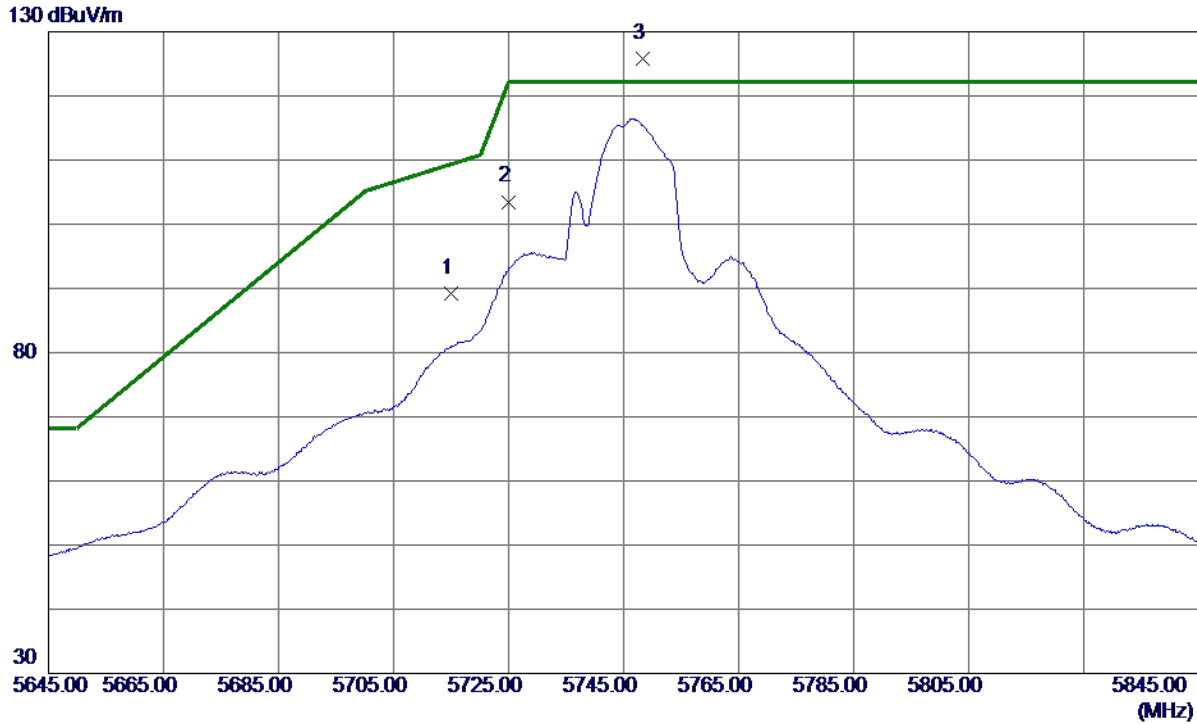

No.	Freq. MHz	Reading Level dBuV/m	Correct Factor dB	Measure ment dBuV/m	Limit dBuV/m	Margin dB	Detector	Comment
1	5715.0000	73.27	15.99	89.26	109.40	-20.14	Peak	
2	5725.0000	87.50	16.00	103.50	122.20	-18.70	Peak	
3 *	5748.4000	109.70	16.01	125.71	122.20	3.51	Peak	No Limit

REMARKS:

- (1) Measurement Value = Reading Level + Correct Factor.
- (2) Margin Level = Measurement Value - Limit Value.

Orthogonal Axis	X
Test Mode	UNII-3_TX AC (VHT20) Mode 5745 MHz

Horizontal

80 dBuV/m

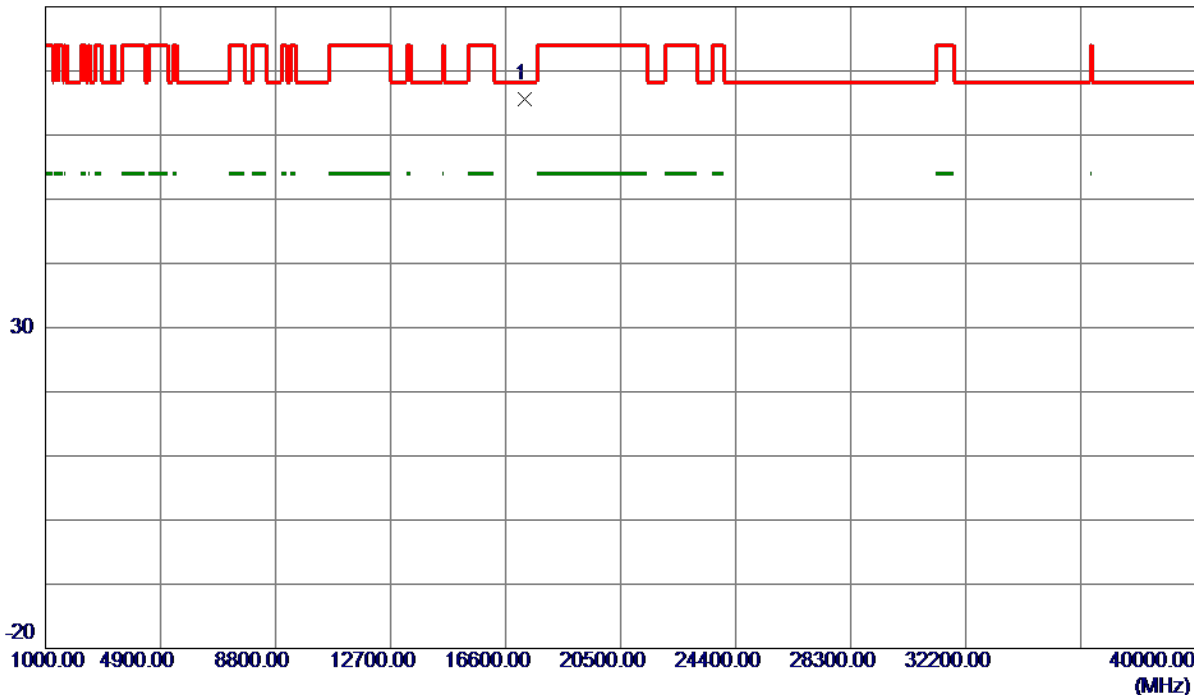

No.	Freq. MHz	Reading Level dBuV/m	Correct Factor dB	Measure ment dBuV/m	Limit dBuV/m	Margin dB	Detector	Comment
1 *	17236.1000	46.66	18.95	65.61	68.30	-2.69	Peak	

REMARKS:

- (1) Measurement Value = Reading Level + Correct Factor.
- (2) Margin Level = Measurement Value - Limit Value.

Orthogonal Axis	X
Test Mode	UNII-3_TX AC (VHT20) Mode 5785 MHz

Vertical

130 dBuV/m

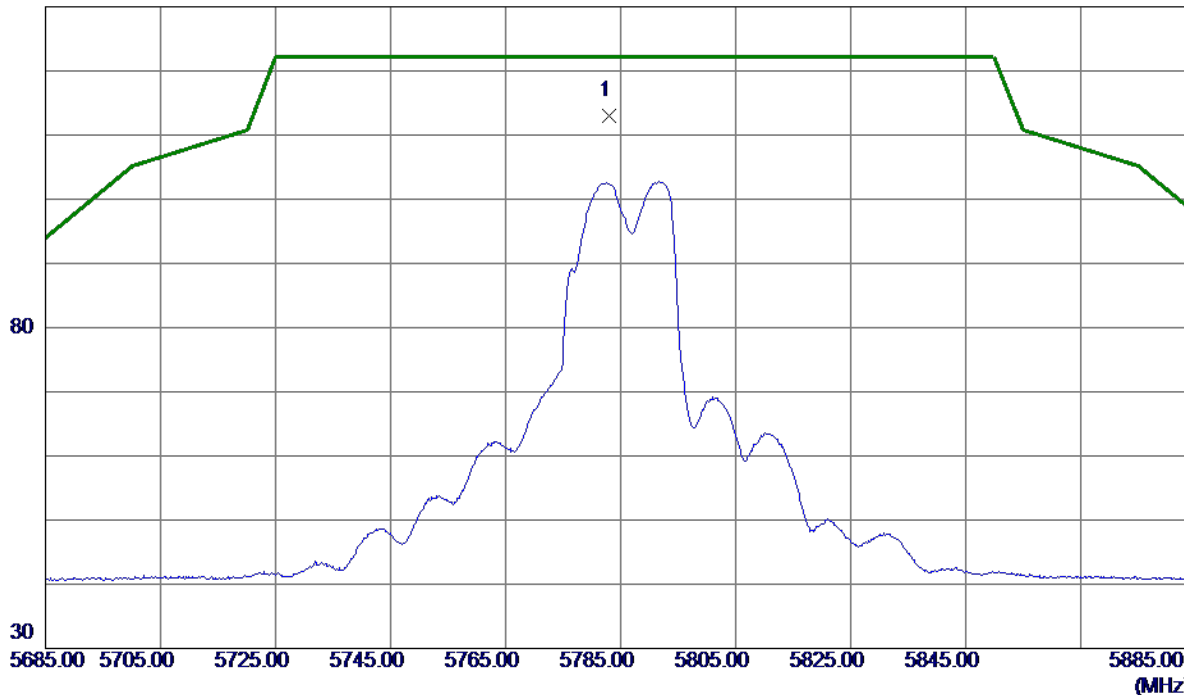

No.	Freq. MHz	Reading Level dBuV/m	Correct Factor dB	Measure ment dBuV/m	Limit dBuV/m	Margin dB	Detector	Comment
1 *	5783.1000	96.98	16.04	113.02	122.20	-9.18	Peak	No Limit

REMARKS:

- (1) Measurement Value = Reading Level + Correct Factor.
- (2) Margin Level = Measurement Value - Limit Value.

Orthogonal Axis	X
Test Mode	UNII-3_TX AC (VHT20) Mode 5785 MHz

Vertical

80 dBuV/m

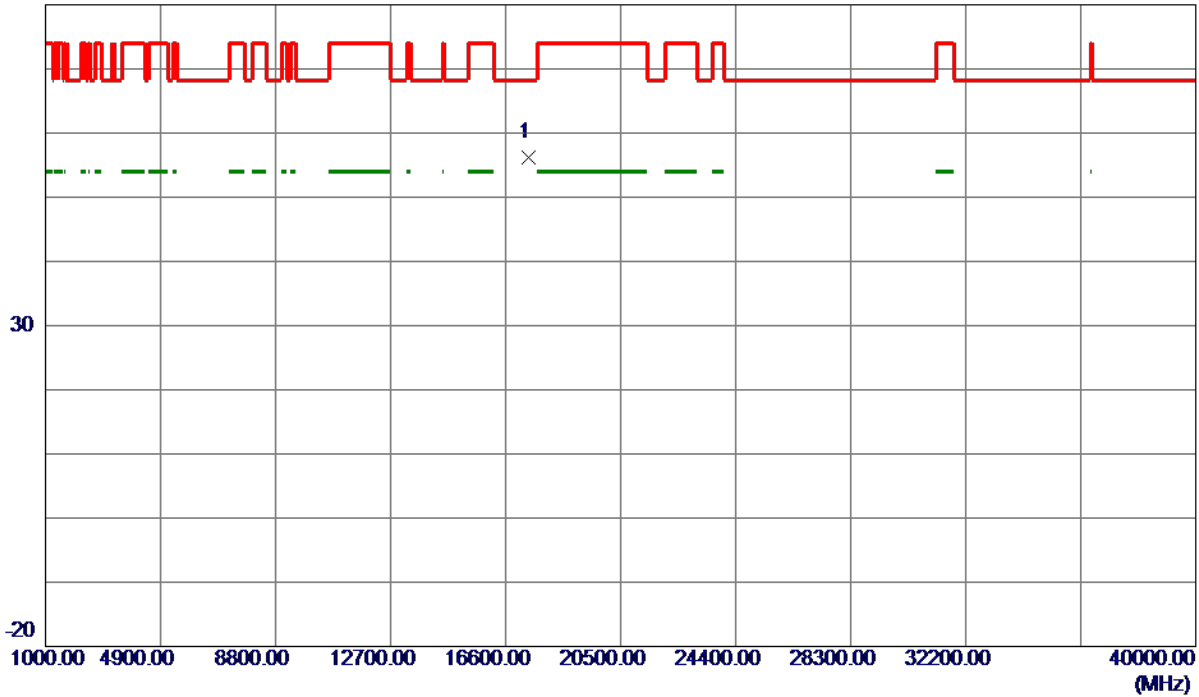

No.	Freq. MHz	Reading Level dBuV/m	Correct Factor dB	Measure ment dBuV/m	Limit dBuV/m	Margin dB	Detector	Comment
1 *	17363.5500	36.76	19.40	56.16	68.30	-12.14	Peak	

REMARKS:

- (1) Measurement Value = Reading Level + Correct Factor.
- (2) Margin Level = Measurement Value - Limit Value.

Orthogonal Axis	X
Test Mode	UNII-3_TX AC (VHT20) Mode 5785 MHz

Horizontal

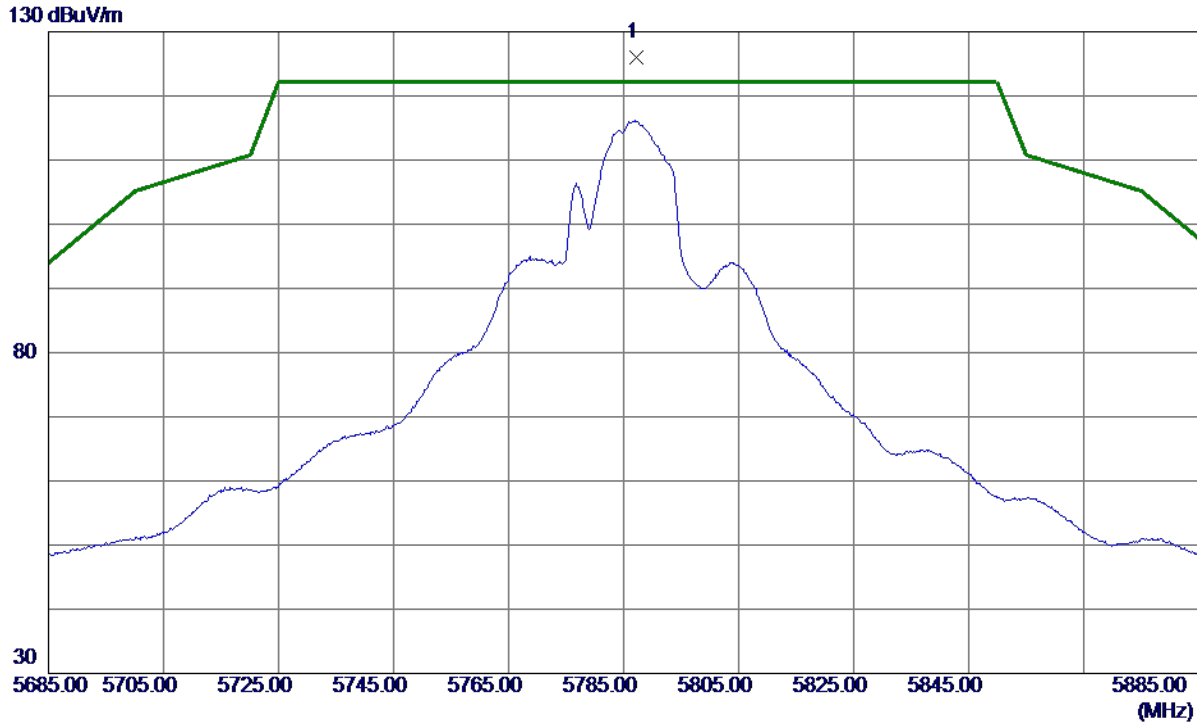

No.	Freq. MHz	Reading Level dBuV/m	Correct Factor dB	Measure ment dBuV/m	Limit dBuV/m	Margin dB	Detector	Comment
1 *	5787.2000	109.91	16.04	125.95	122.20	3.75	Peak	No Limit

REMARKS:

- (1) Measurement Value = Reading Level + Correct Factor.
- (2) Margin Level = Measurement Value - Limit Value.

Orthogonal Axis	X
Test Mode	UNII-3_TX AC (VHT20) Mode 5785 MHz

Horizontal

80 dBuV/m

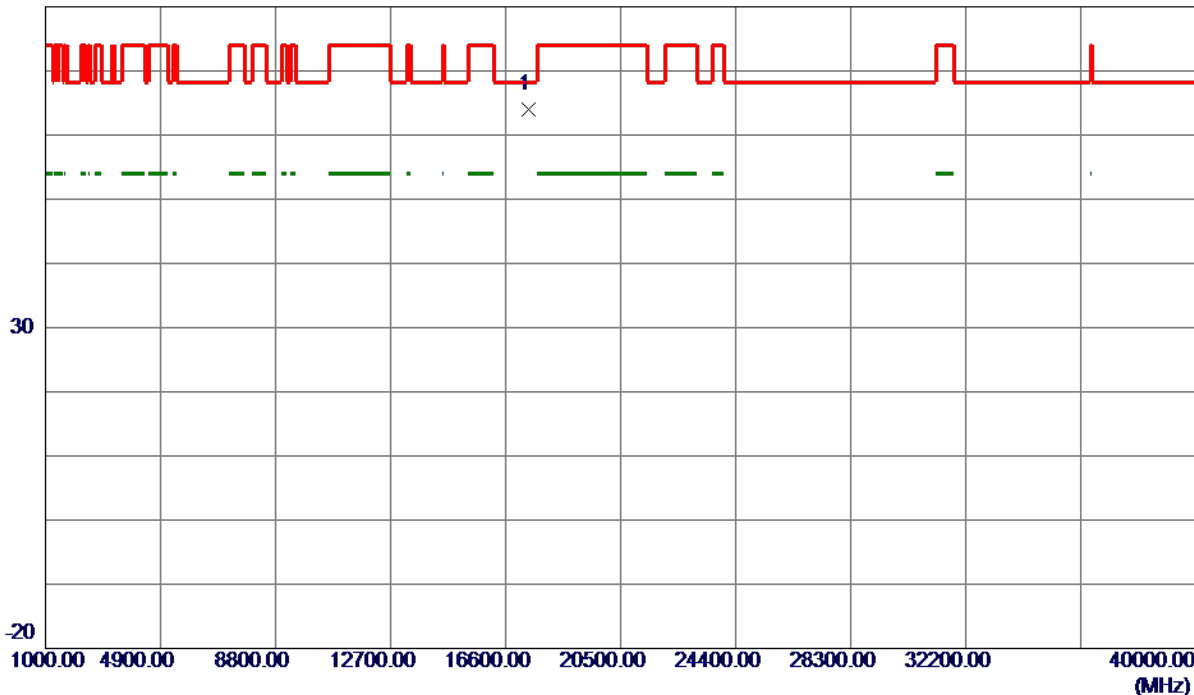

No.	Freq. MHz	Reading Level dBuV/m	Correct Factor dB	Measure ment dBuV/m	Limit dBuV/m	Margin dB	Detector	Comment
1 *	17359.0000	44.69	19.38	64.07	68.30	-4.23	Peak	

REMARKS:

- (1) Measurement Value = Reading Level + Correct Factor.
- (2) Margin Level = Measurement Value - Limit Value.

Orthogonal Axis	X
Test Mode	UNII-3_TX AC (VHT20) Mode 5825 MHz

Vertical

130 dBuV/m



No.	Freq. MHz	Reading Level dBuV/m	Correct Factor dB	Measure ment dBuV/m	Limit dBuV/m	Margin dB	Detector	Comment
1 *	5831.3000	99.19	16.07	115.26	122.20	-6.94	Peak	No Limit
2	5850.0000	70.44	16.08	86.52	122.20	-35.68	Peak	
3	5860.0000	57.21	16.08	73.29	109.40	-36.11	Peak	

REMARKS:

- (1) Measurement Value = Reading Level + Correct Factor.
- (2) Margin Level = Measurement Value - Limit Value.

Orthogonal Axis	X
Test Mode	UNII-3_TX AC (VHT20) Mode 5825 MHz

Vertical

80 dBuV/m

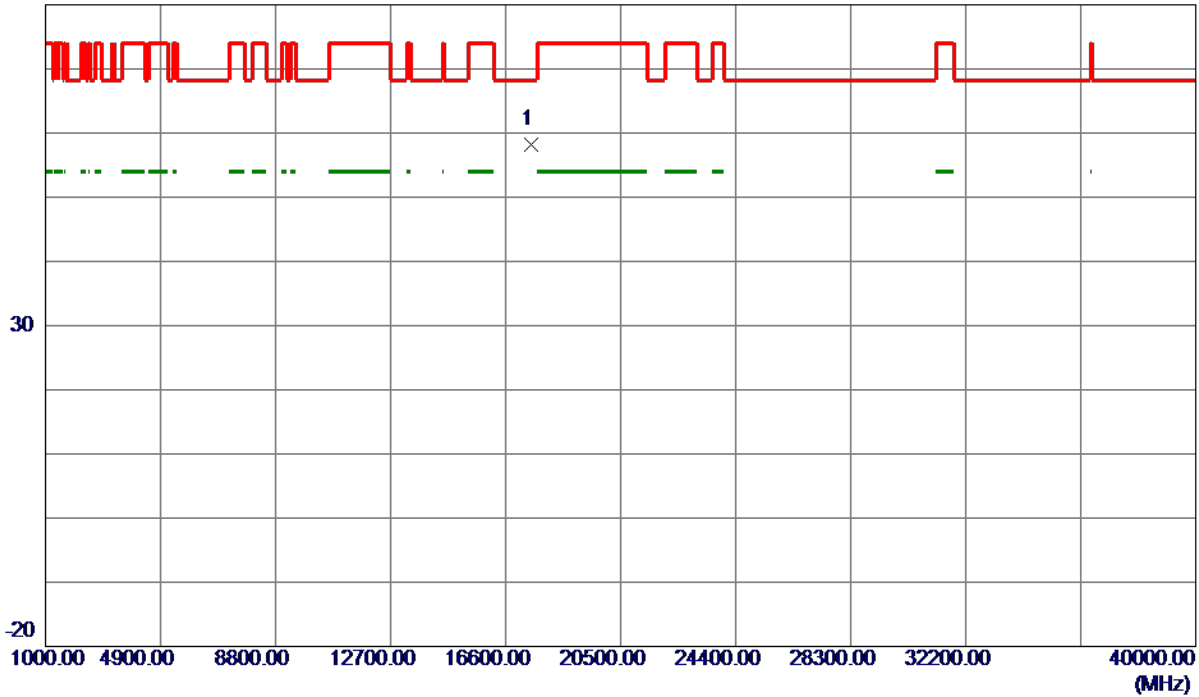

No.	Freq. MHz	Reading Level dBuV/m	Correct Factor dB	Measure ment dBuV/m	Limit dBuV/m	Margin dB	Detector	Comment
1 *	17467.6800	38.48	19.76	58.24	68.30	-10.06	Peak	

REMARKS:

- (1) Measurement Value = Reading Level + Correct Factor.
- (2) Margin Level = Measurement Value - Limit Value.

Orthogonal Axis	X
Test Mode	UNII-3_TX AC (VHT20) Mode 5825 MHz

Horizontal

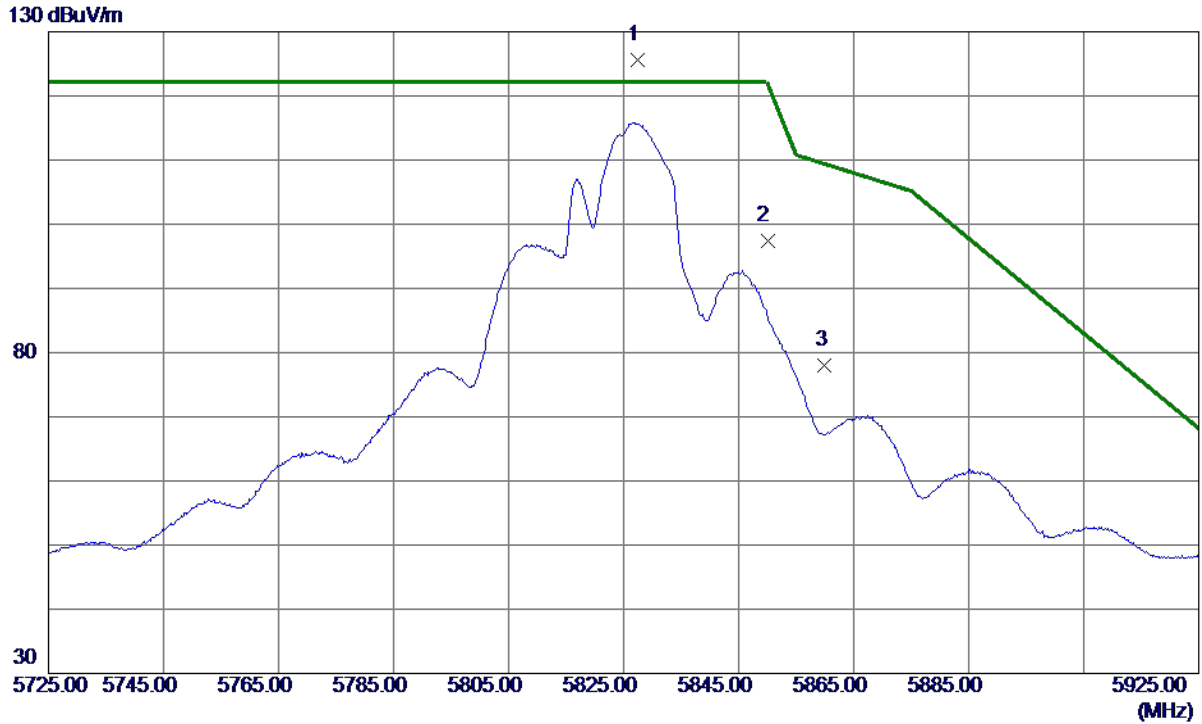

No.	Freq. MHz	Reading Level dBuV/m	Correct Factor dB	Measure ment dBuV/m	Limit dBuV/m	Margin dB	Detector	Comment
1 *	5827.4000	109.63	16.06	125.69	122.20	3.49	Peak	No Limit
2	5850.0000	81.39	16.08	97.47	122.20	-24.73	Peak	
3	5860.0000	61.92	16.08	78.00	109.40	-31.40	Peak	

REMARKS:

- (1) Measurement Value = Reading Level + Correct Factor.
- (2) Margin Level = Measurement Value - Limit Value.

Orthogonal Axis	X
Test Mode	UNII-3_TX AC (VHT20) Mode 5825 MHz

Horizontal

80 dBuV/m

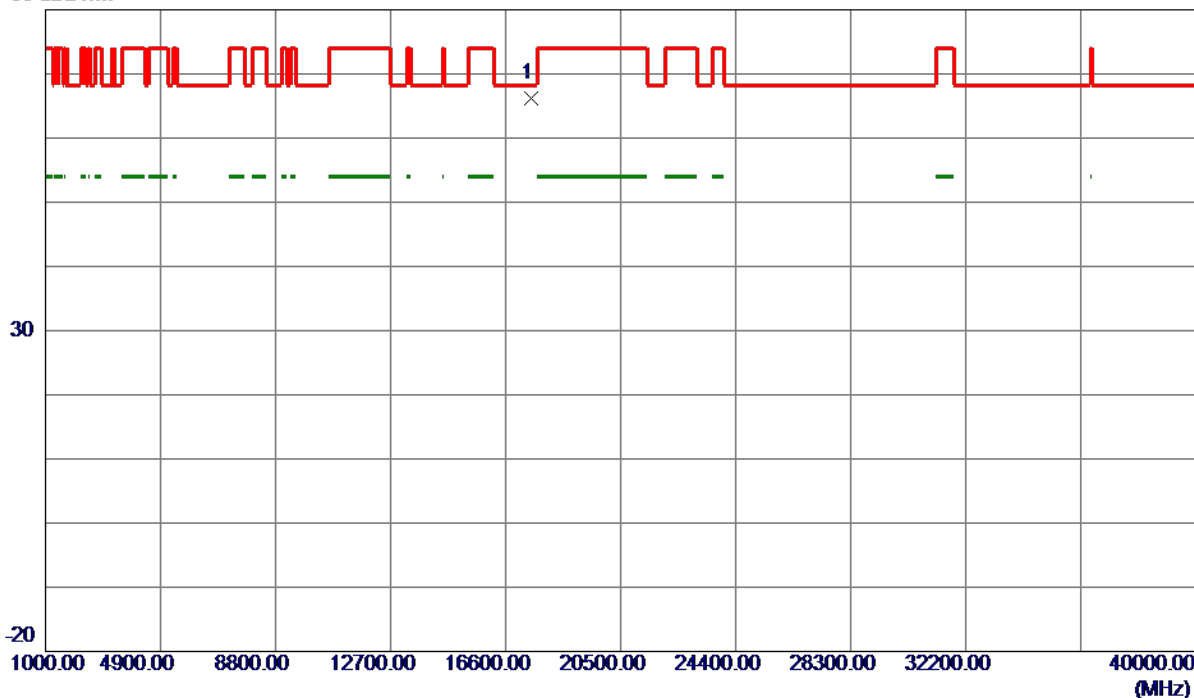

No.	Freq. MHz	Reading Level dBuV/m	Correct Factor dB	Measure ment dBuV/m	Limit dBuV/m	Margin dB	Detector	Comment
1 *	17477.0000	46.32	19.79	66.11	68.30	-2.19	Peak	

REMARKS:

- (1) Measurement Value = Reading Level + Correct Factor.
- (2) Margin Level = Measurement Value - Limit Value.

Orthogonal Axis	X
Test Mode	UNII-3_TX AC (VHT40) Mode 5755 MHz

Vertical

130 dBuV/m

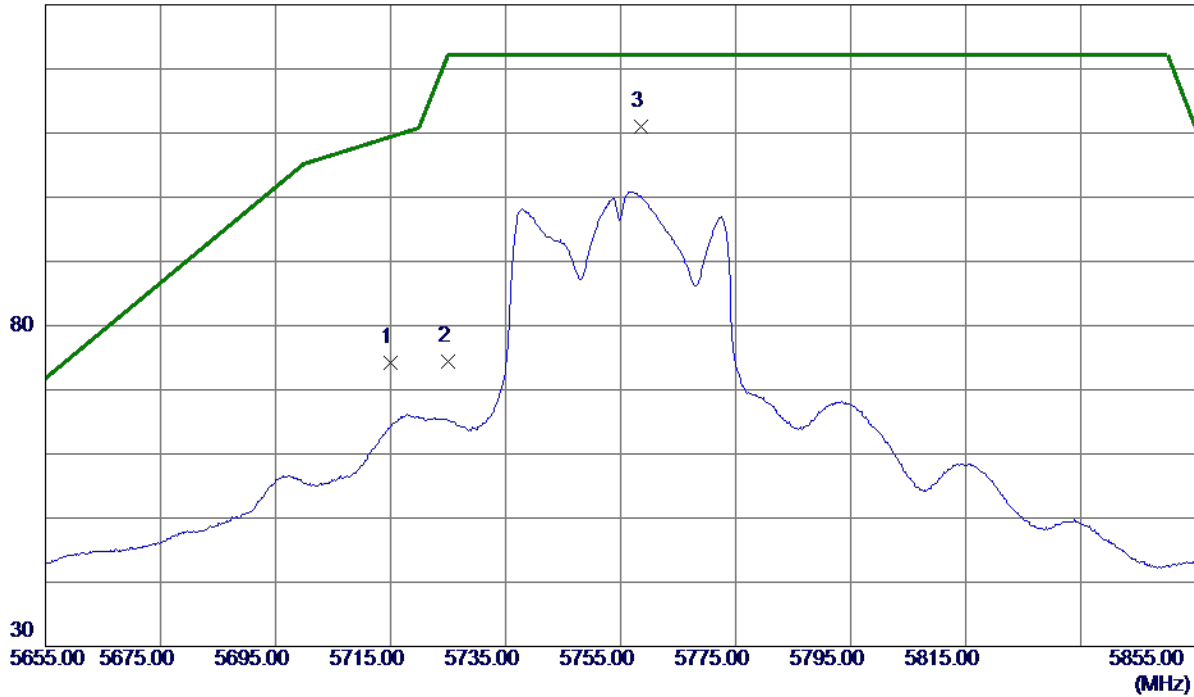

No.	Freq. MHz	Reading Level dBuV/m	Correct Factor dB	Measure ment dBuV/m	Limit dBuV/m	Margin dB	Detector	Comment
1	5715.0000	58.29	15.99	74.28	109.40	-35.12	Peak	
2	5725.0000	58.44	16.00	74.44	122.20	-47.76	Peak	
3 *	5758.5000	94.93	16.02	110.95	122.20	-11.25	Peak	No Limit

REMARKS:

- (1) Measurement Value = Reading Level + Correct Factor.
- (2) Margin Level = Measurement Value - Limit Value.

Orthogonal Axis	X
Test Mode	UNII-3_TX AC (VHT40) Mode 5755 MHz

Vertical

80 dBuV/m

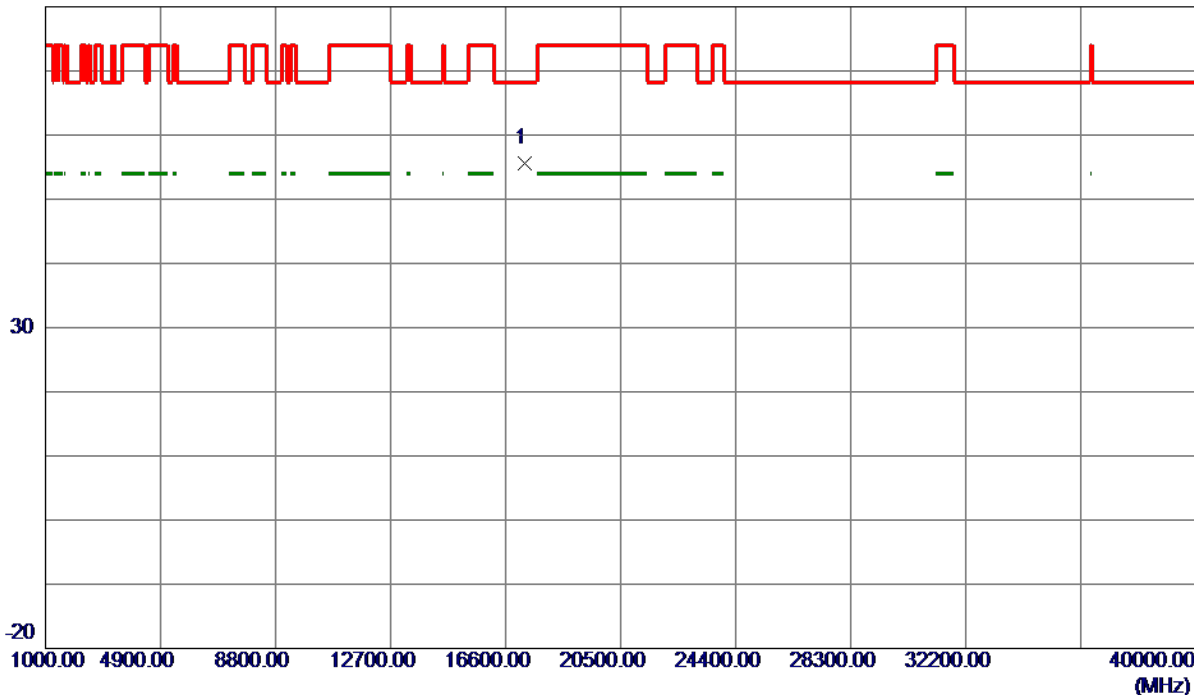

No.	Freq. MHz	Reading Level dBuV/m	Correct Factor dB	Measure ment dBuV/m	Limit dBuV/m	Margin dB	Detector	Comment
1 *	17257.6300	36.60	19.03	55.63	68.30	-12.67	Peak	

REMARKS:

- (1) Measurement Value = Reading Level + Correct Factor.
- (2) Margin Level = Measurement Value - Limit Value.

Orthogonal Axis	X
Test Mode	UNII-3_TX AC (VHT40) Mode 5755 MHz

Horizontal

130 dBuV/m

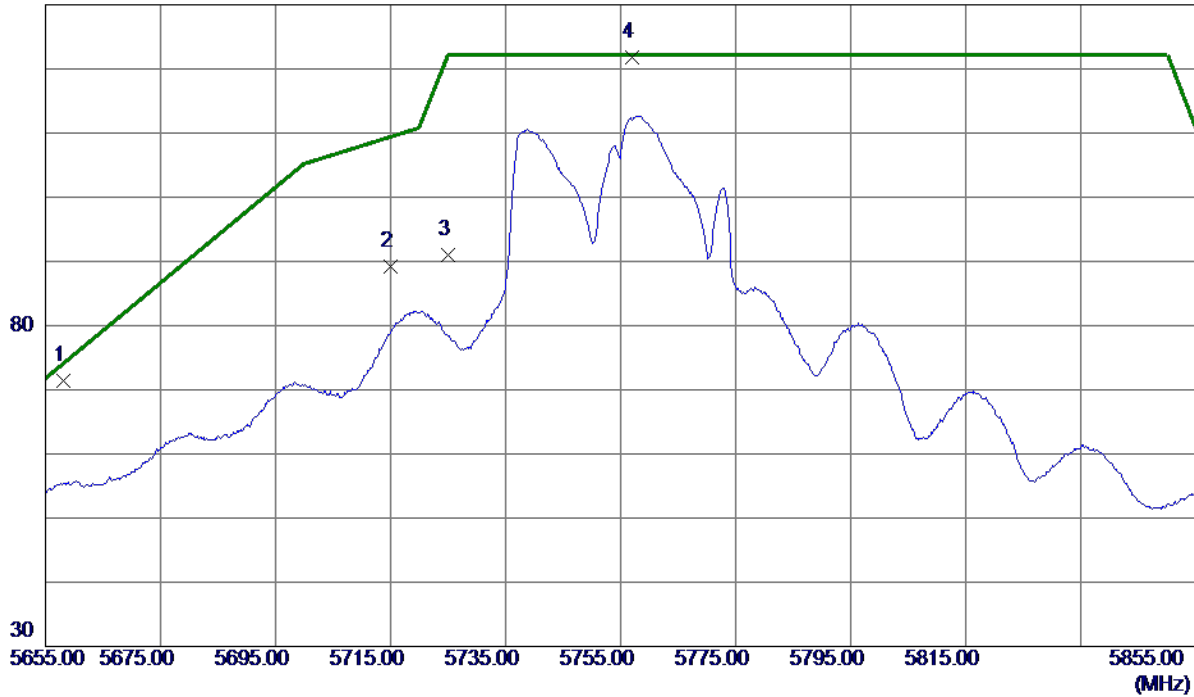

No.	Freq. MHz	Reading Level dBuV/m	Correct Factor dB	Measure ment dBuV/m	Limit dBuV/m	Margin dB	Detector	Comment
1	5658.1000	55.52	15.96	71.48	74.19	-2.71	Peak	
2	5715.0000	73.24	15.99	89.23	109.40	-20.17	Peak	
3	5725.0000	75.02	16.00	91.02	122.20	-31.18	Peak	
4 *	5756.9000	105.76	16.02	121.78	122.20	-0.42	Peak	No Limit

REMARKS:

- (1) Measurement Value = Reading Level + Correct Factor.
- (2) Margin Level = Measurement Value - Limit Value.

Orthogonal Axis	X
Test Mode	UNII-3_TX AC (VHT40) Mode 5755 MHz

Horizontal

80 dBuV/m

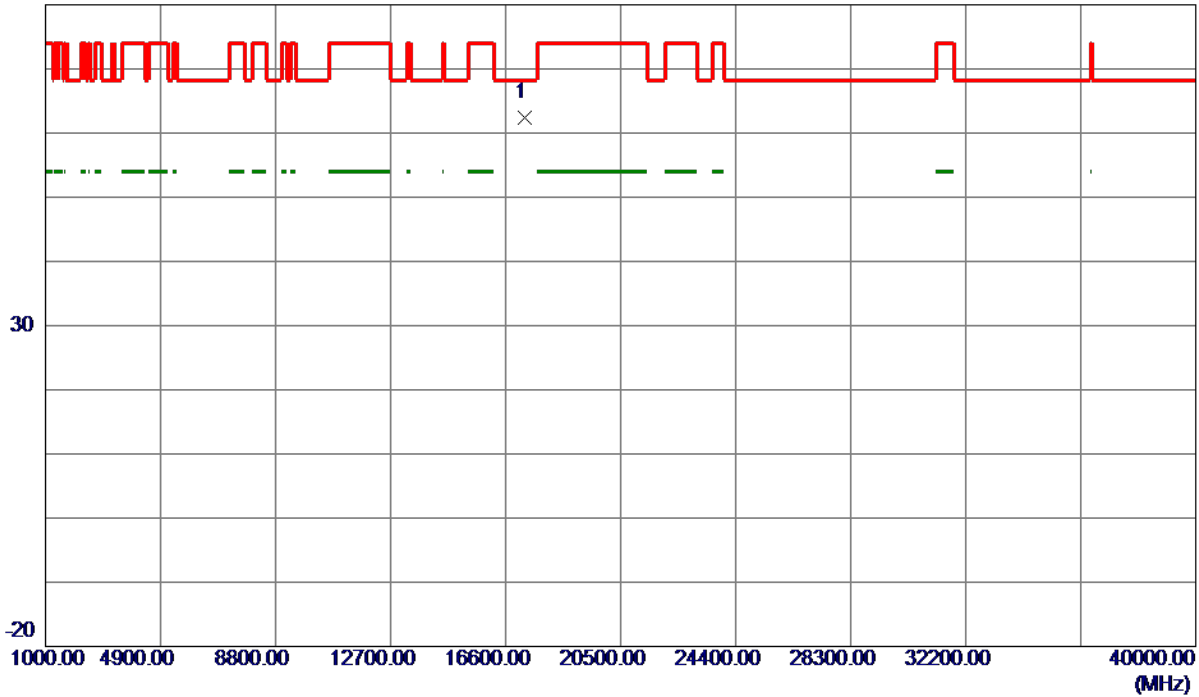

No.	Freq. MHz	Reading Level dBuV/m	Correct Factor dB	Measure ment dBuV/m	Limit dBuV/m	Margin dB	Detector	Comment
1 *	17266.8000	43.35	19.06	62.41	68.30	-5.89	Peak	

REMARKS:

- (1) Measurement Value = Reading Level + Correct Factor.
- (2) Margin Level = Measurement Value - Limit Value.

Orthogonal Axis	X
Test Mode	UNII-3_TX AC (VHT40) Mode 5795 MHz

Vertical

130 dBuV/m

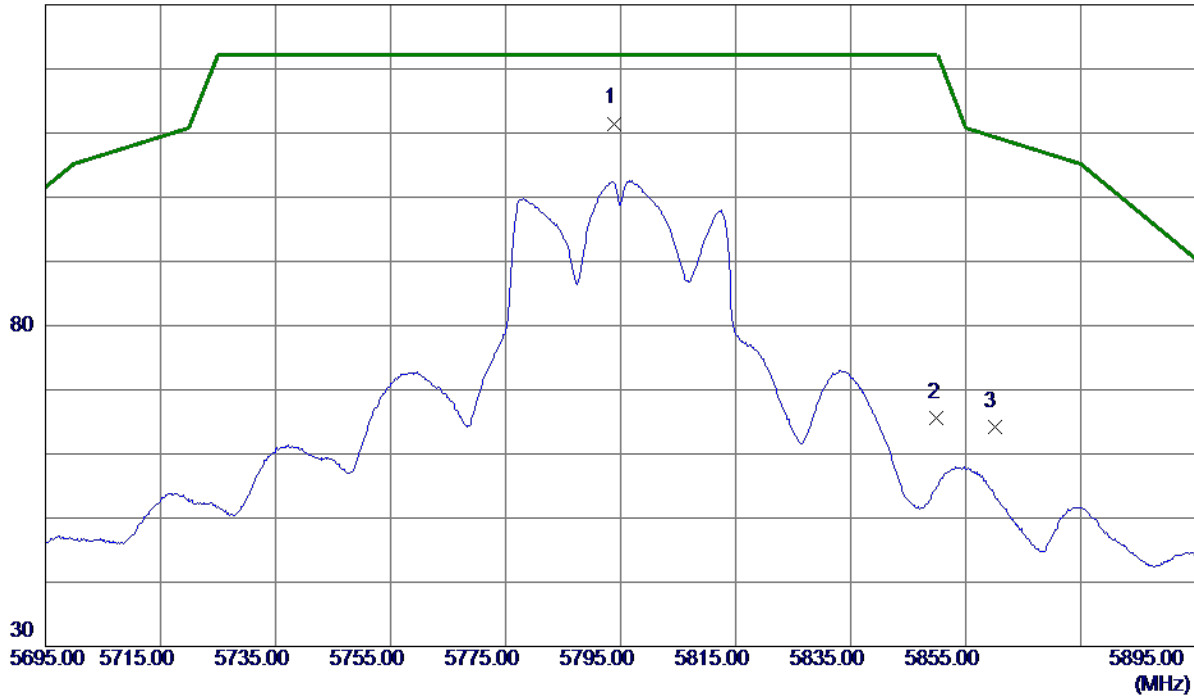

No.	Freq. MHz	Reading Level dBuV/m	Correct Factor dB	Measure ment dBuV/m	Limit dBuV/m	Margin dB	Detector	Comment
1 *	5793.8000	95.46	16.04	111.50	122.20	-10.70	Peak	No Limit
2	5850.0000	49.46	16.08	65.54	122.20	-56.66	Peak	
3	5860.0000	48.12	16.08	64.20	109.40	-45.20	Peak	

REMARKS:

- (1) Measurement Value = Reading Level + Correct Factor.
- (2) Margin Level = Measurement Value - Limit Value.

Orthogonal Axis	X
Test Mode	UNII-3_TX AC (VHT40) Mode 5795 MHz

Vertical

80 dBuV/m

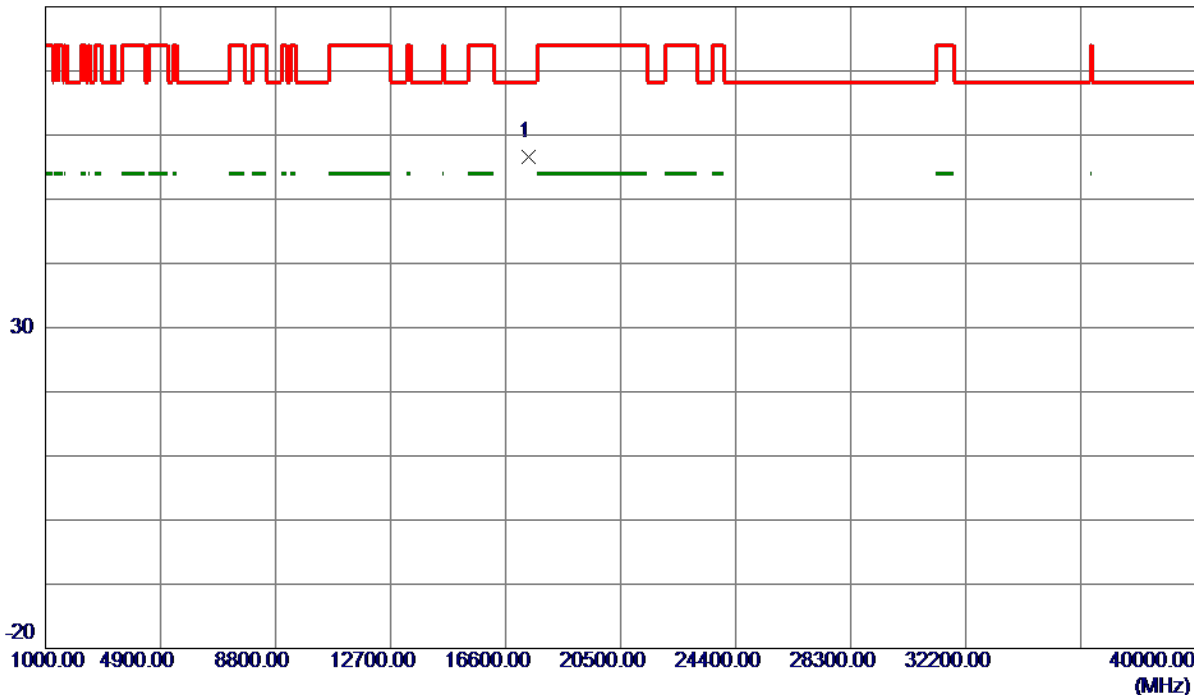

No.	Freq. MHz	Reading Level dBuV/m	Correct Factor dB	Measure ment dBuV/m	Limit dBuV/m	Margin dB	Detector	Comment
1 *	17383.0200	37.21	19.46	56.67	68.30	-11.63	Peak	

REMARKS:

- (1) Measurement Value = Reading Level + Correct Factor.
- (2) Margin Level = Measurement Value - Limit Value.

Orthogonal Axis	X
Test Mode	UNII-3_TX AC (VHT40) Mode 5795 MHz

Horizontal

130 dBuV/m

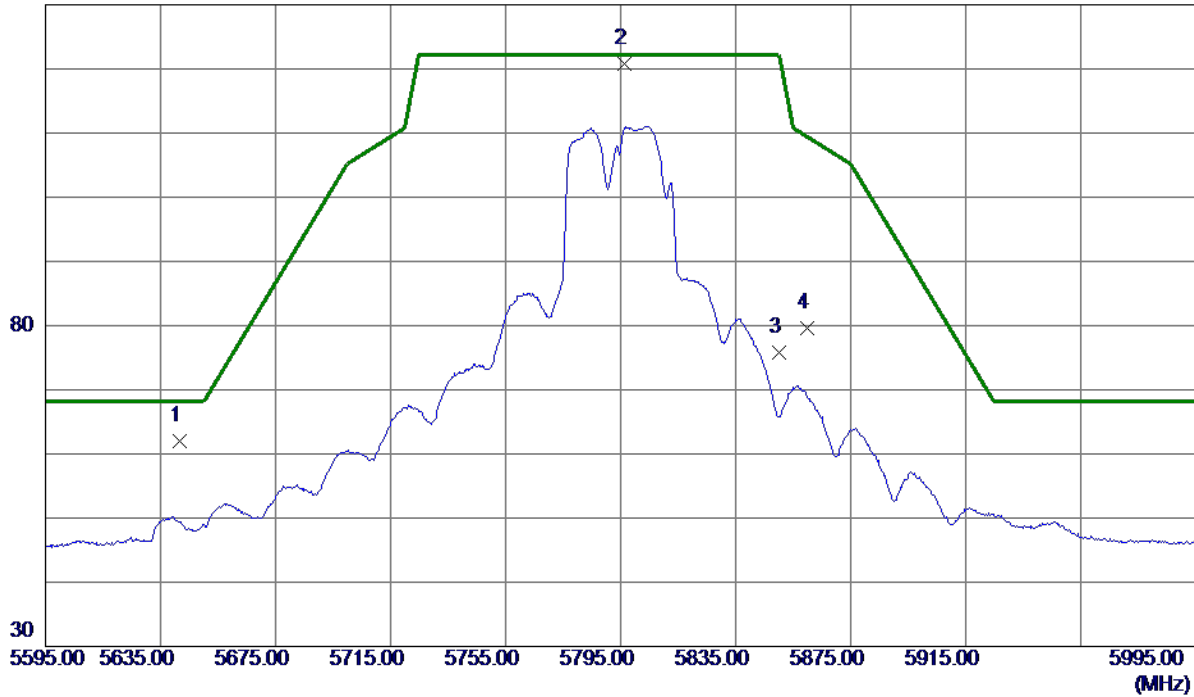

No.	Freq. MHz	Reading Level dBuV/m	Correct Factor dB	Measure ment dBuV/m	Limit dBuV/m	Margin dB	Detector	Comment
1	5641.8000	46.39	15.52	61.91	68.20	-6.29	Peak	
2 *	5796.2000	104.97	15.80	120.77	122.20	-1.43	Peak	No Limit
3	5850.0000	59.88	15.90	75.78	122.20	-46.42	Peak	
4	5860.0000	63.72	15.92	79.64	109.40	-29.76	Peak	

REMARKS:

- (1) Measurement Value = Reading Level + Correct Factor.
- (2) Margin Level = Measurement Value - Limit Value.

Orthogonal Axis	X
Test Mode	UNII-3_TX AC (VHT40) Mode 5795 MHz

Horizontal

80 dBuV/m

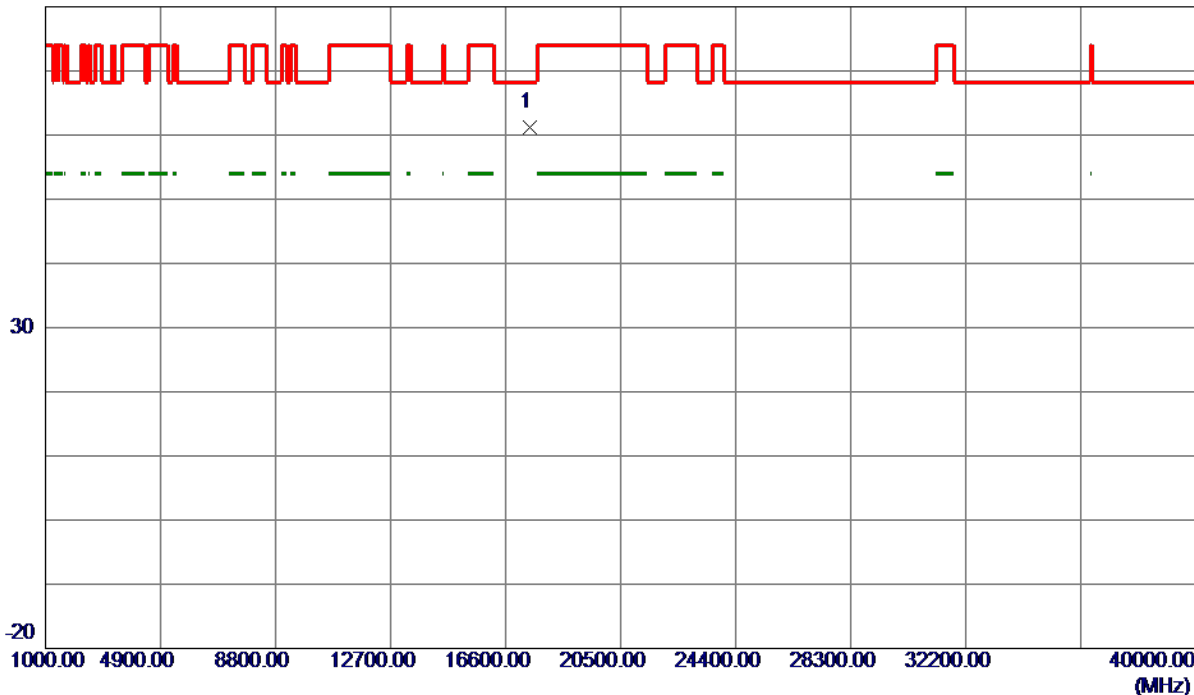

No.	Freq. MHz	Reading Level dBuV/m	Correct Factor dB	Measure ment dBuV/m	Limit dBuV/m	Margin dB	Detector	Comment
1 *	17406.5500	41.72	19.54	61.26	68.30	-7.04	Peak	

REMARKS:

- (1) Measurement Value = Reading Level + Correct Factor.
- (2) Margin Level = Measurement Value - Limit Value.