

FCC Radio Test Report

FCC ID: TVE-37146T064

This report concerns: **Original Grant**

Project No. : 1906C186
Equipment : Secured Wireless Access Point
Brand Name : FORTINET
Test Model : FAP-321E
Series Model : FAP-321Exxxxxx, FortiAP 321Exxxxxx, FORTIAP-321Exxxxxx
(where "x" can be used as "A-Z" or "0-9" or "-" or blank for software changes or marking purposes only)
Applicant : Fortinet, Inc.
Address : 899 Kifer Road, Sunnyvale, CA 94086 USA
Manufacturer : SHENZHEN TENDA TECHNOLOGY CO.,LTD
Address : 6-8 Floor, Tower E3, No. 1001, Zhongshanyuan Road, Nanshan District, Shenzhen, China. 518052
Date of Receipt : Jun. 28, 2019
Date of Test : Jul. 01, 2019 ~ Oct. 10, 2019
Issued Date : Oct. 23, 2019
Report Version : R00
Test Sample : Engineering Sample No.: DG19062851
Standard(s) : FCC Part15, Subpart C (15.247)
ANSI C63.10-2013
KDB 558074 D01 15.247 Meas Guidance v05r02
FCC KDB 662911 D01 Multiple Transmitter Output v02r01

The above equipment has been tested and found compliance with the requirement of the relative standards by BTL Inc.

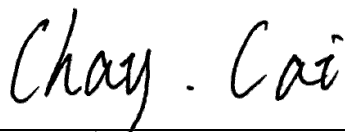

Prepared by : Chay Cai



Approved by : Ethan Ma



Certificate #5123.02

Add: No.3, Jinshagang 1st Road, Shixia, Dalang Town, Dongguan, Guangdong, China.

Tel: +86-769-8318-3000

Web: www.newbtl.com

Declaration

BTL represents to the client that testing is done in accordance with standard procedures as applicable and that test instruments used has been calibrated with standards traceable to international standard(s) and/or national standard(s).

BTL's reports apply only to the specific samples tested under conditions. It is manufacture's responsibility to ensure that additional production units of this model are manufactured with the identical electrical and mechanical components. **BTL** shall have no liability for any declarations, inferences or generalizations drawn by the client or others from **BTL** issued reports.

The report must not be used by the client to claim product certification, approval, or endorsement by NVLAP, NIST, A2LA, or any agency of the U.S. Government.

This report is the confidential property of the client. As a mutual protection to the clients, the public and ourselves, the test report shall not be reproduced, except in full, without our written approval.

BTL's laboratory quality assurance procedures are in compliance with the **ISO/IEC 17025** requirements, and accredited by the conformity assessment authorities listed in this test report.

BTL is not responsible for the sampling stage, so the results only apply to the sample as received.

The information, data and test plan are provided by manufacturer which may affect the validity of results, so it is manufacturer's responsibility to ensure that the apparatus meets the essential requirements of applied standards and in all the possible configurations as representative of its intended use.

Limitation

For the use of the authority's logo is limited unless the Test Standard(s)/Scope(s)/Item(s) mentioned in this test report is (are) included in the conformity assessment authorities acceptance respective.

Please note that the measurement uncertainty is provided for informational purpose only and are not use in determining the Pass/Fail results.

Table of Contents	Page
REPORT ISSUED HISTORY	6
1 . SUMMARY OF TEST RESULTS	7
1.1 TEST FACILITY	8
1.2 MEASUREMENT UNCERTAINTY	8
1.3 TEST ENVIRONMENT CONDITIONS	8
2 . GENERAL INFORMATION	9
2.1 GENERAL DESCRIPTION OF EUT	9
2.2 DESCRIPTION OF TEST MODES	11
2.3 PARAMETERS OF TEST SOFTWARE	13
2.4 DUTY CYCLE	14
2.5 BLOCK DIAGRAM SHOWING THE CONFIGURATION OF SYSTEM TESTED	15
2.6 SUPPORT UNITS	15
3 . AC POWER LINE CONDUCTED EMISSIONS TEST	16
3.1 LIMIT	16
3.2 TEST PROCEDURE	16
3.3 DEVIATION FROM TEST STANDARD	16
3.4 TEST SETUP	17
3.5 EUT OPERATION CONDITIONS	17
3.6 TEST RESULTS	17
4 . RADIATED EMISSIONS TEST	18
4.1 LIMIT	18
4.2 TEST PROCEDURE	19
4.3 DEVIATION FROM TEST STANDARD	19
4.4 TEST SETUP	20
4.5 EUT OPERATION CONDITIONS	21
4.6 TEST RESULTS - 9 KHZ TO 30 MHZ	21
4.7 TEST RESULTS - 30 MHZ TO 1000 MHZ	21
4.8 TEST RESULTS - ABOVE 1000 MHZ	21
5 . BANDWIDTH TEST	22
5.1 LIMIT	22
5.2 TEST PROCEDURE	22
5.3 DEVIATION FROM STANDARD	22

Table of Contents	Page
5.4 TEST SETUP	22
5.5 EUT OPERATION CONDITIONS	22
5.6 TEST RESULTS	22
6 . MAXIMUM OUTPUT POWER TEST	23
6.1 LIMIT	23
6.2 TEST PROCEDURE	23
6.3 DEVIATION FROM STANDARD	23
6.4 TEST SETUP	23
6.5 EUT OPERATION CONDITIONS	23
6.6 TEST RESULTS	23
7 . CONDUCTED SPURIOUS EMISSIONS	24
7.1 LIMIT	24
7.2 TEST PROCEDURE	24
7.3 DEVIATION FROM STANDARD	24
7.4 TEST SETUP	24
7.5 EUT OPERATION CONDITIONS	24
7.6 TEST RESULTS	24
8 . POWER SPECTRAL DENSITY TEST	25
8.1 LIMIT	25
8.2 TEST PROCEDURE	25
8.3 DEVIATION FROM STANDARD	25
8.4 TEST SETUP	25
8.5 EUT OPERATION CONDITIONS	25
8.6 TEST RESULTS	25
9 . MEASUREMENT INSTRUMENTS LIST	26
10 . EUT TEST PHOTO	28
APPENDIX A - AC POWER LINE CONDUCTED EMISSIONS	32
APPENDIX B - RADIATED EMISSION - 9 KHZ TO 30 MHZ	35
APPENDIX C - RADIATED EMISSION - 30 MHZ TO 1000 MHZ	40
APPENDIX D - RADIATED EMISSION- ABOVE 1000 MHZ	43
APPENDIX E - BANDWIDTH	92
APPENDIX F - MAXIMUM OUTPUT POWER	97

Table of Contents

Page

APPENDIX G - CONDUCTED SPURIOUS EMISSIONS

104

APPENDIX H - POWER SPECTRAL DENSITY

117

REPORT ISSUED HISTORY

Report Version	Description	Issued Date
R00	Original Issue.	Oct. 23, 2019

1. SUMMARY OF TEST RESULTS

Test procedures according to the technical standard(s):

FCC Part15, Subpart C (15.247)				
Standard(s) Section	Test Item	Test Result	Judgment	Remark
15.207	AC Power Line Conducted Emissions	APPENDIX A	PASS	-----
15.247(d) 15.205(a) 15.209(a)	Radiated Emissions	APPENDIX B APPENDIX C APPENDIX D	PASS	-----
15.247(a)(2)	Bandwidth	APPENDIX E	PASS	-----
15.247(b)(3)	Maximum Output Power	APPENDIX F	PASS	-----
15.247(d)	Conducted Spurious Emissions	APPENDIX G	PASS	-----
15.247(e)	Power Spectral Density	APPENDIX H	PASS	-----
15.203	Antenna Requirement	-----	PASS	Note(2)

Note:

- (1) "N/A" denotes test is not applicable in this test report.
- (2) The device what use a permanently attached antenna were considered sufficient to comply with the provisions of 15.203.

1.1 TEST FACILITY

The test facilities used to collect the test data in this report is at the location of No.3,Jinshagang 1st Road, Shixia, Dalang Town, Dongguan, Guangdong, China.

BTL's Test Firm Registration Number for FCC: 357015

BTL's Designation Number for FCC: CN1240

1.2 MEASUREMENT UNCERTAINTY

ISO/IEC 17025 requires that an estimate of the measurement uncertainties associated with the emissions test results be included in the report. The measurement uncertainties given below are based on a 95% confidence level (based on a coverage factor (k=2))

The BTL measurement uncertainty as below table:

A. AC power line conducted emissions test:

Test Site	Method	Measurement Frequency Range	U, (dB)
DG-C02	CISPR	150 kHz ~ 30 MHz	2.32

B. Radiated emissions test:

Test Site	Method	Measurement Frequency Range	Ant. H / V	U, (dB)
DG-CB03	CISPR	9kHz ~ 30MHz	V	3.79
		9kHz ~ 30MHz	H	3.57
		30MHz ~ 200MHz	V	4.88
		30MHz ~ 200MHz	H	4.14
		200MHz ~ 1,000MHz	V	4.62
		200MHz ~ 1,000MHz	H	4.80
		1GHz ~ 6GHz	-	4.58
		6GHz ~ 18GHz	-	5.18
		18GHz ~ 26.5GHz	-	3.80
		26.5GHz ~ 40GHz	-	4.30

Note: Unless specifically mentioned, the uncertainty of measurement has not been taken into account to declare the compliance or non-compliance to the specification.

1.3 TEST ENVIRONMENT CONDITIONS

Test Item	Temperature	Humidity	Test Voltage	Tested By
AC Power Line Conducted Emissions	25°C	53%	AC 120V/60Hz	Robin Zhuang
Radiated Emissions-9K-30MHz	25°C	60%	AC 120V/60Hz	Robin Zhuang
Radiated Emissions-30 MHz to 1GHz	24°C	68%	AC 120V/60Hz	Sheldon Ou
Radiated Emissions-Above 1000 MHz	24°C	68%	AC 120V/60Hz	Sheldon Ou
Bandwidth	24°C	65%	AC 120V/60Hz	Jonas Chen
Maximum output power	24°C	65%	AC 120V/60Hz	Jonas Chen
Conducted Spurious Emissions	24°C	65%	AC 120V/60Hz	Jonas Chen
Power Spectral Density	24°C	65%	AC 120V/60Hz	Jonas Chen

2. GENERAL INFORMATION

2.1 GENERAL DESCRIPTION OF EUT

Equipment	Secured Wireless Access Point
Brand Name	FORTINET
Test Model	FAP-321E
Series Model	FAP-321Exxxxxx, FortiAP 321Exxxxxx, FORTIAP-321Exxxxxx (where "x" can be used as "A-Z" or "0-9" or "-" or blank for software changes or marking purposes only)
Model Difference(s)	Only differ in model name.
Power Source	1# DC voltage supplied from AC/DC adapter. Model: WA-30J12R 2# DC voltage supplied from POE adapter.
Power Rating	1# I/P: 100-240V~ 50-60Hz 0.9A Max. O/P: 12V --- 2.5A 2# DC 48V
Operation Frequency	2412 MHz ~ 2462 MHz
Modulation Type	IEEE 802.11b: DSSS IEEE 802.11g: OFDM IEEE 802.11n: OFDM
Bit Rate of Transmitter	IEEE 802.11b: 11/5.5/2/1 Mbps IEEE 802.11g: 54/48/36/24/18/12/9/6 Mbps IEEE 802.11n: up to 450 Mbps
Maximum Output Power Non-Beamforming	IEEE 802.11b: 29.97 dBm (0.9923 W) IEEE 802.11g: 29.95 dBm (0.9875 W) IEEE 802.11n (HT20): 29.99 dBm (0.9982 W) IEEE 802.11n (HT40): 29.91 dBm (0.9787 W)
Maximum Output Power Beamforming	IEEE 802.11n (HT20): 28.36 dBm (0.6858 W) IEEE 802.11n (HT40): 28.35 dBm (0.6832 W)

Note:

1. For a more detailed features description, please refer to the manufacturer's specifications or the user's manual.

2. Channel List:

CH01 - CH11 for IEEE 802.11b, IEEE 802.11g, IEEE 802.11n (HT20) CH03 - CH09 for IEEE 802.11n (HT40)							
Channel	Frequency (MHz)	Channel	Frequency (MHz)	Channel	Frequency (MHz)	Channel	Frequency (MHz)
01	2412	04	2427	07	2442	10	2457
02	2417	05	2432	08	2447	11	2462
03	2422	06	2437	09	2452		

3. Antenna Specification:

Ant.	Brand	Model Name	Antenna Type	Connector	Gain (dBi)
1	Tenda	N/A	Internal	IPEX	3.0
2	Tenda	N/A	Internal	IPEX	3.0
3	Tenda	N/A	Internal	IPEX	3.0

Note: This EUT supports CDD, and all antennas have the same gain,

(1) For Non Beamforming function, Directional gain= $G_{ANT} + \text{Array Gain}$,
 For output power measurements, Array Gain=0, so, Directional gain=3.0
 For power spectral density measurements, Array Gain= $10\log(N_{ANT}/N_{SS})$ dB
 Directional gain= $3.0 + 10\log(3/1) = 7.77$. So, the power density limit is $8 - 7.77 + 6 = 6.23$

(2) For Beamforming function, Beamforming gain: 4.5dB, so Directional gain= $3.0 + 4.5 = 7.50$
 Then, the output Power limit is $30 - 7.50 + 6 = 28.50$

4. The worst case for 3TX as follow:

For Non Beamforming:

Operating Mode / TX Mode	3TX
IEEE 802.11b	V (Ant. 1+Ant. 2+Ant. 3)
IEEE 802.11g	V (Ant. 1+Ant. 2+Ant. 3)
IEEE 802.11n(HT20)	V (Ant. 1+Ant. 2+Ant. 3)
IEEE 802.11n(HT40)	V (Ant. 1+Ant. 2+Ant. 3)

For Beamforming:

Operating Mode / TX Mode	3TX
IEEE 802.11n(HT20)	V (Ant. 1+Ant. 2+Ant. 3)
IEEE 802.11n(HT40)	V (Ant. 1+Ant. 2+Ant. 3)

2.2 DESCRIPTION OF TEST MODES

The test system was pre-tested based on the consideration of all possible combinations of EUT operation mode.

Pretest Mode	Description
Mode 1	TX B Mode Channel 01/06/11
Mode 2	TX G Mode Channel 01/06/11
Mode 3	TX N-20 MHz Mode Channel 01/06/11
Mode 4	TX N-40 MHz Mode Channel 03/06/09
Mode 5	TX N-20 MHz Mode Channel 11

Following mode(s) was (were) found to be the worst case(s) and selected for the final test.

AC power line conducted emissions test	
Final Test Mode:	Description
Mode 5	TX N-20 MHz Mode Channel 11

Radiated emissions test - Below 1GHz	
Final Test Mode:	Description
Mode 5	TX N-20 MHz Mode Channel 11

Radiated emissions test- Above 1GHz	
Final Test Mode:	Description
Mode 1	TX B Mode Channel 01/06/11
Mode 2	TX G Mode Channel 01/06/11
Mode 3	TX N-20 MHz Mode Channel 01/06/11
Mode 4	TX N-40 MHz Mode Channel 03/06/09

Output Power test for Non Beamforming	
Final Test Mode:	Description
Mode 1	TX B Mode Channel 01/06/11
Mode 2	TX G Mode Channel 01/06/11
Mode 3	TX N-20 MHz Mode Channel 01/06/11
Mode 4	TX N-40 MHz Mode Channel 03/06/09

Output Power test for With Beamforming	
Final Test Mode:	Description
Mode 3	TX N-20 MHz Mode Channel 01/06/11
Mode 4	TX N-40 MHz Mode Channel 03/06/09

Others Conducted test for Non Beamforming	
Final Test Mode:	Description
Mode 1	TX B Mode Channel 01/06/11
Mode 2	TX G Mode Channel 01/06/11
Mode 3	TX N-20 MHz Mode Channel 01/06/11
Mode 4	TX N-40 MHz Mode Channel 03/06/09

NOTE:

- (1) The measurements are performed at the high, middle, low available channels.
- (2) 802.11b mode: CCK (1 Mbps)
 802.11g mode: OFDM (6 Mbps)
 802.11n HT20 mode : BPSK (6.5 Mbps)
 802.11n HT40 mode : BPSK (13.5 Mbps)
 For all tests, the highest output powers were set for final test.
- (3) For radiated emission below 1 GHz test, the IEEE 802.11n20 Channel 11 is found to be the worst case and recorded.
- (4) For radiated emission above 1 GHz test, 1GHz~26.5GHz have been pre-tested and in this report only recorded the worst case. The remaining spurious points are all below the limit value of 20dB.
- (5) The measurements for Power were tested, the worst case were Non - Beamforming, only worst case were documented for other test items

2.3 PARAMETERS OF TEST SOFTWARE

Non-Beamforming

Test Software	cart		
Frequency (MHz)	2412	2437	2462
IEEE 802.11b	20	21	21
IEEE 802.11g	14	14	15
IEEE 802.11n (HT20)	14	15	16
Frequency (MHz)	2422	2437	2452
IEEE 802.11n (HT40)	13.5	18	16

Beamforming

Test Software	cart		
Frequency (MHz)	2412	2437	2462
IEEE 802.11n (HT20)	14	13	13.5
Frequency (MHz)	2422	2437	2452
IEEE 802.11n (HT40)	13.5	16	15.5

2.4 DUTY CYCLE

If duty cycle is $\geq 98\%$, duty factor is not required.
 If duty cycle is $< 98\%$, duty factor shall be considered.

IEEE 802.11b

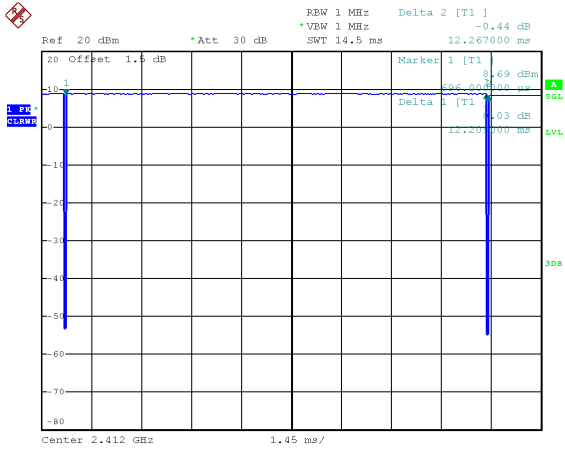

Date: 4.JUL.2019 10:36:32

Duty cycle = $12.209 \text{ ms} / 12.267 \text{ ms} = 99.53\%$
 Duty Factor = $10 \log(1/\text{Duty cycle}) = 0.00$

IEEE 802.11n (HT20)

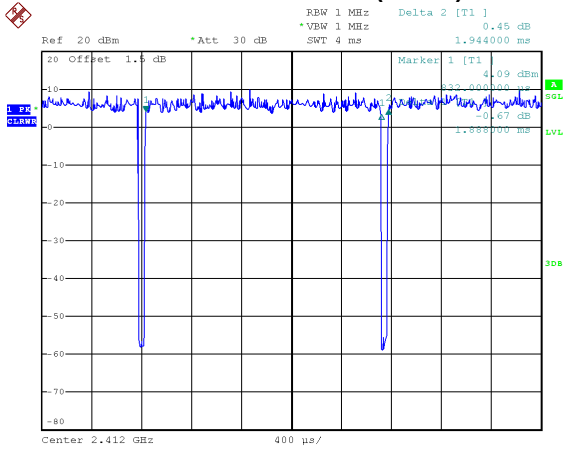

Date: 4.JUL.2019 10:37:30

Duty cycle = $1.888 \text{ ms} / 1.944 \text{ ms} = 97.12\%$
 Duty Factor = $10 \log(1/\text{Duty cycle}) = 0.13$,

IEEE 802.11g

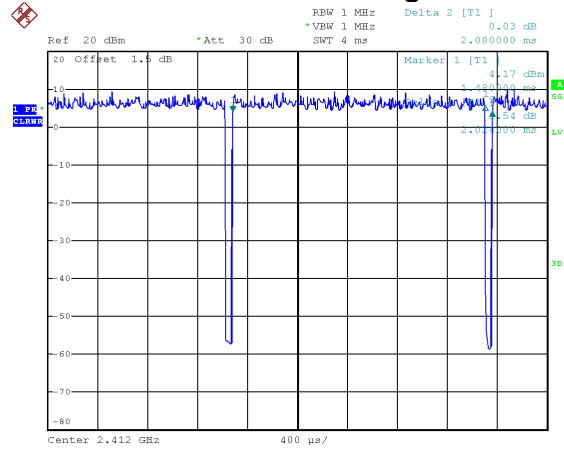

Date: 4.JUL.2019 10:37:02

Duty cycle = $2.024 \text{ ms} / 2.080 \text{ ms} = 97.31\%$
 Duty Factor = $10 \log(1/\text{Duty cycle}) = 0.12$

IEEE 802.11n (HT40)

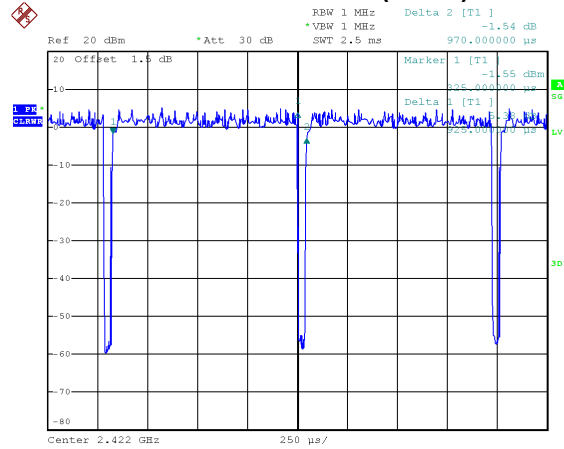

Date: 4.JUL.2019 10:37:52

Duty cycle = $0.925 \text{ ms} / 0.970 \text{ ms} = 95.36\%$
 Duty Factor = $10 \log(1/\text{Duty cycle}) = 0.21$

NOTE:

For IEEE 802.11g and IEEE 802.11n (HT20):

For radiated emissions frequency above 1 GHz, the resolution bandwidth of test receiver/spectrum analyzer is 1 MHz and the video bandwidth is 1 kHz (Duty cycle $< 98\%$).

For IEEE 802.11n (HT40):

For radiated emissions frequency above 1 GHz, the resolution bandwidth of test receiver/spectrum analyzer is 1 MHz and the video bandwidth is 2 kHz (Duty cycle $< 98\%$).

2.5 BLOCK DIAGRAM SHOWING THE CONFIGURATION OF SYSTEM TESTED

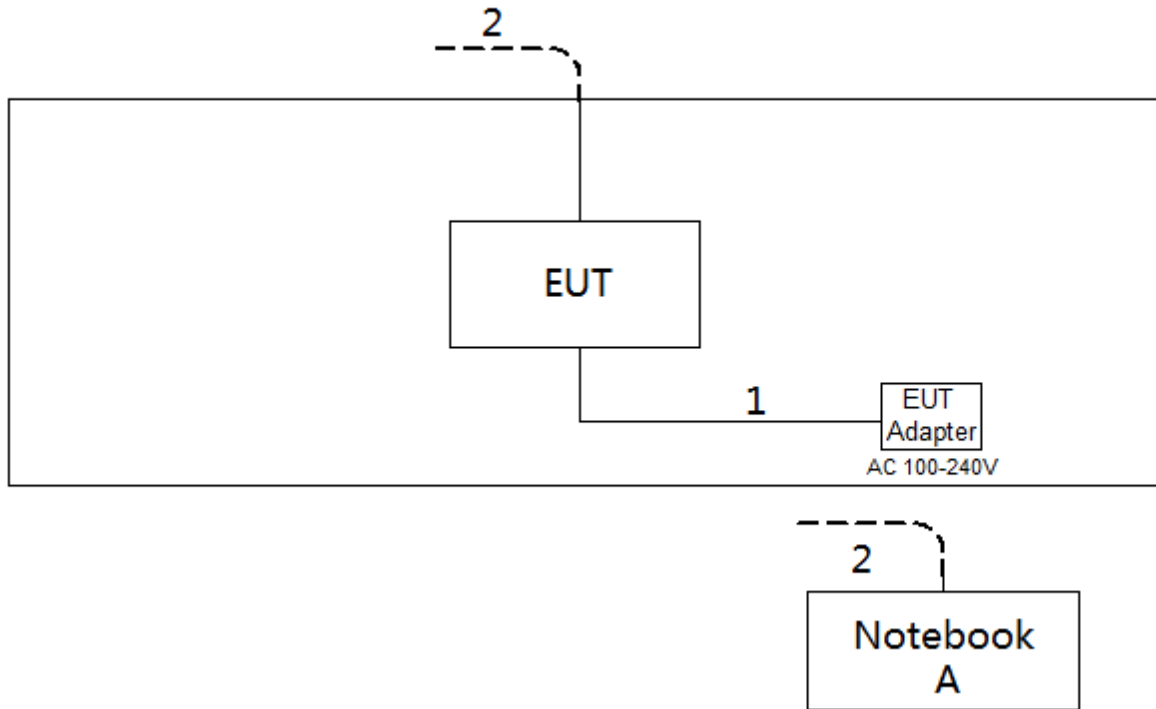

2.6 SUPPORT UNITS

Item	Equipment	Brand	Model No.	Series No.
A	Notebook	Dell	Inspiron 15-7559	N/A

Item	Cable Type	Shielded Type	Ferrite Core	Length
1	DC Cable	NO	NO	1.5m
2	RJ45 Cable	NO	NO	10m

3. AC POWER LINE CONDUCTED EMISSIONS TEST

3.1 LIMIT

Frequency of Emission (MHz)	Limit (dB μ V)	
	Quasi-peak	Average
0.15 - 0.50	66 to 56*	56 to 46*
0.50 - 5.0	56	46
5.0 - 30.0	60	50

NOTE:

- (1) The tighter limit applies at the band edges.
- (2) The limit of " * " marked band means the limitation decreases linearly with the logarithm of the frequency in the range.

The following table is the setting of the receiver

Receiver Parameters	Setting
Attenuation	10 dB
Start Frequency	0.15 MHz
Stop Frequency	30 MHz
IF Bandwidth	9 kHz

3.2 TEST PROCEDURE

- a. The EUT was placed 0.8 meters from the horizontal ground plane with EUT being connected to the power mains through a line impedance stabilization network (LISN). All other support equipment powered from additional LISN(s). The LISN provide 50 Ohm/ 50uH of coupling impedance for the measuring instrument.
- b. Interconnecting cables that hang closer than 40 cm to the ground plane shall be folded back and forth in the center forming a bundle 30 to 40 cm long.
- c. I/O cables that are not connected to a peripheral shall be bundled in the center. The end of the cable may be terminated, if required, using the correct terminating impedance. The overall length shall not exceed 1 m.
- d. LISN at least 80 cm from nearest part of EUT chassis.
- e. For the actual test configuration, please refer to the related Item -EUT Test Photos.

3.3 DEVIATION FROM TEST STANDARD

No deviation

3.4 TEST SETUP

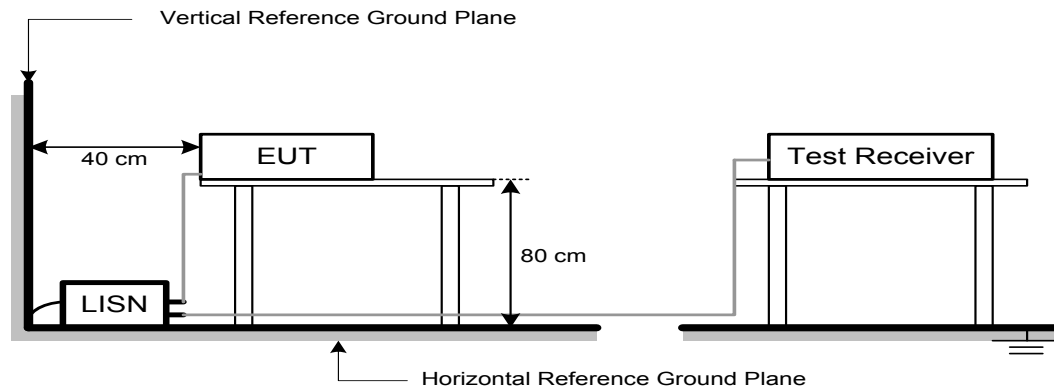

3.5 EUT OPERATION CONDITIONS

EUT was programmed to be in continuously transmitting mode.

3.6 TEST RESULTS

Please refer to the APPENDIX A.

4. RADIATED EMISSIONS TEST

4.1 LIMIT

In case the emission fall within the restricted band specified on 15.205(a), then the 15.209(a) limit in the table below has to be followed.

LIMITS OF RADIATED EMISSION MEASUREMENT (9 kHz-1000 MHz)

Frequency (MHz)	Field Strength (microvolts/meter)	Measurement Distance (meters)
0.009-0.490	2400/F(kHz)	300
0.490-1.705	24000/F(kHz)	30
1.705-30.0	30	30
30-88	100	3
88-216	150	3
216-960	200	3
Above 960	500	3

LIMITS OF RADIATED EMISSION MEASUREMENT (Above 1000 MHz)

Frequency (MHz)	(dBuV/m at 3 m)	
	Peak	Average
Above 1000	74	54

NOTE:

- (1) The limit for radiated test was performed according to FCC PART 15C.
- (2) The tighter limit applies at the band edges.
- (3) Emission level (dBuV/m)=20log Emission level (uV/m).

Spectrum Parameter	Setting
Attenuation	Auto
Start Frequency	1000 MHz
Stop Frequency	10th carrier harmonic
RBW / VBW (Emission in restricted band)	1 MHz / 3 MHz for Peak, 1 MHz / 1/T for Average

Receiver Parameter	Setting
Attenuation	Auto
Start ~ Stop Frequency	9 kHz~90 kHz for PK/AVG detector
Start ~ Stop Frequency	90 kHz~110 kHz for QP detector
Start ~ Stop Frequency	110 kHz~490 kHz for PK/AVG detector
Start ~ Stop Frequency	490 kHz~30 MHz for QP detector
Start ~ Stop Frequency	30 MHz~1000 MHz for QP detector

4.2 TEST PROCEDURE

- a. The measuring distance of 3 m shall be used for measurements. The EUT was placed on the top of a rotating table 0.8 meter above the ground at a 3 meter semi-anechoic chamber. The table was rotated 360 degrees to determine the position of the highest radiation.(below 1 GHz)
- b. The measuring distance of 3 m shall be used for measurements. The EUT was placed on the top of a rotating table 1.5 meter above the ground at a 3 meter semi-anechoic chamber. The table was rotated 360 degrees to determine the position of the highest radiation.(above 1 GHz)
- c. The height of the equipment or of the substitution antenna shall be 0.8m or 1.5m; the height of the test antenna shall vary between 1 m to 4 m. Both horizontal and vertical polarizations of the antenna are set to make the measurement.
- d. For each suspected emission, the EUT was arranged to its worst case and then the antenna was tuned to heights find the maximum reading (used Bore sight function).
- e. The receiver system was set to peak and average detect function and specified bandwidth with maximum hold mode when the test frequency is above 1 GHz.
- f. The initial step in collecting radiated emission data is a receiver peak detector mode pre-scanning the measurement frequency range. Significant peaks are then marked and then Quasi Peak detector mode re-measured.
- g. All readings are Peak unless otherwise stated QP in column of Note. Peak denotes that the Peak reading compliance with the QP Limits and then QP Mode measurement didn't perform. (below 1 GHz)
- h. All readings are Peak Mode value unless otherwise stated AVG in column of Note. If the Peak Mode Measured value compliance with the Peak Limits and lower than AVG Limits, the EUT shall be deemed to meet both Peak & AVG Limits and then only Peak Mode was measured, but AVG Mode didn't perform. (above 1 GHz)
- i. For the actual test configuration, please refer to the related Item -EUT Test Photos.

4.3 DEVIATION FROM TEST STANDARD

No deviation

4.4 TEST SETUP

9 kHz-30 MHz

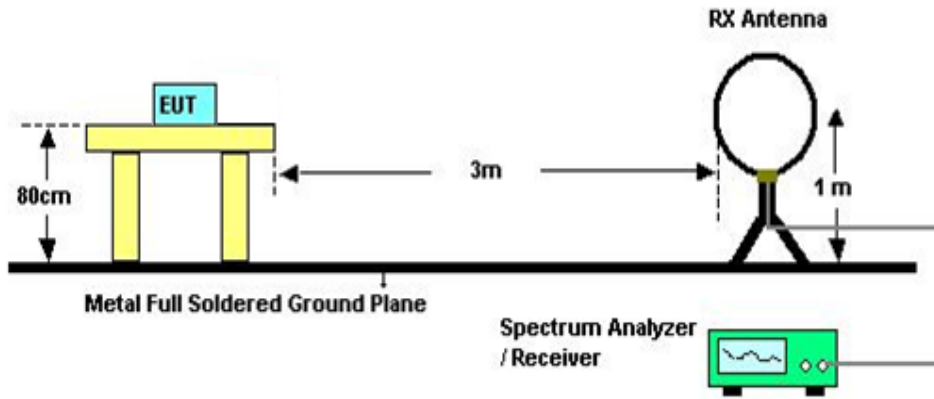

30 MHz to 1 GHz

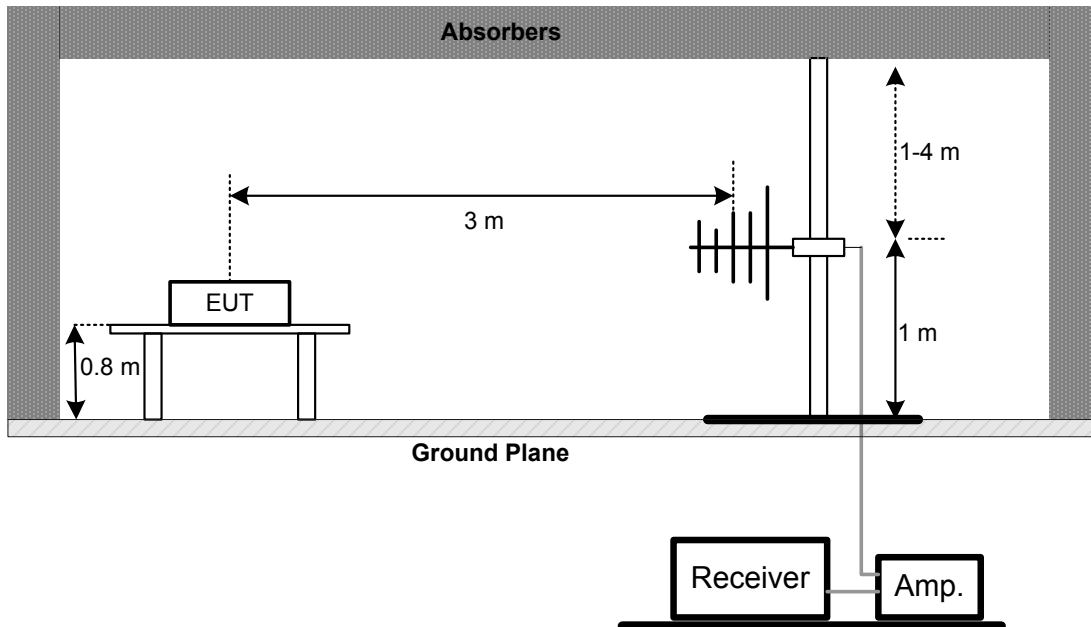

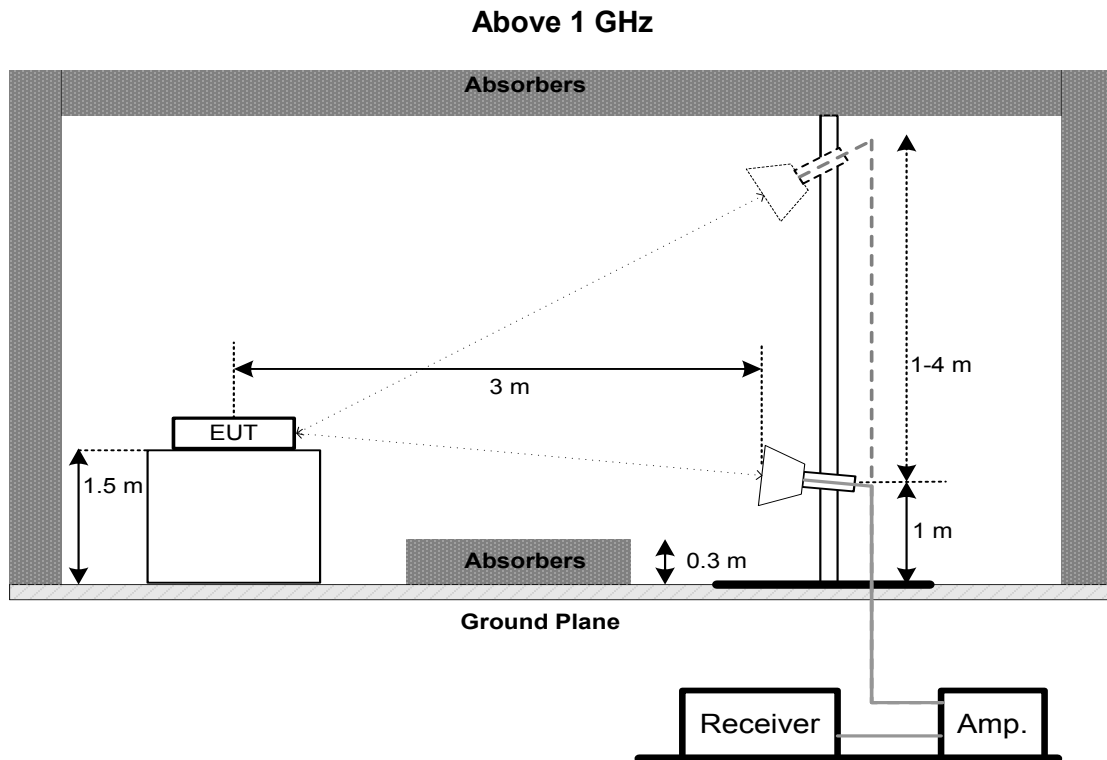

4.5 EUT OPERATION CONDITIONS

The EUT was programmed to be in continuously transmitting mode.

4.6 TEST RESULTS - 9 KHZ TO 30 MHZ

Please refer to the APPENDIX B

Remark:

- (1) Distance extrapolation factor = $40 \log (\text{specific distance} / \text{test distance})$ (dB).
- (2) Limit line = specific limits (dBuV) + distance extrapolation factor.

4.7 TEST RESULTS - 30 MHZ TO 1000 MHZ

Please refer to the APPENDIX C.

4.8 TEST RESULTS - ABOVE 1000 MHZ

Please refer to the APPENDIX D.

Remark:

- (1) No limit: This is fundamental signal, the judgment is not applicable.
For fundamental signal judgment was referred to Peak output test.

5. BANDWIDTH TEST

5.1 LIMIT

FCC Part15, Subpart C (15.247)		
Section	Test Item	Limit
15.247(a)(2)	6 dB Bandwidth	Minimum 500 kHz
	99% Emission Bandwidth	-

5.2 TEST PROCEDURE

- The EUT was directly connected to the spectrum analyzer and antenna output port as show in the block diagram below.
- For 6dB Bandwidth Spectrum setting: RBW= 100KHz, VBW=300KHz, Sweep time = 2.5 ms.
For 99% OBW Spectrum Setting: For B,G,N20 mode: RBW= 300KHz, VBW=1MHz, For N40 mode: RBW= 1MHz, VBW=3MHz, Sweep time = 2.5 ms.
- The bandwidth was performed in accordance with method 11.8.1 of ANSI C63.10-2013.

5.3 DEVIATION FROM STANDARD

No deviation.

5.4 TEST SETUP

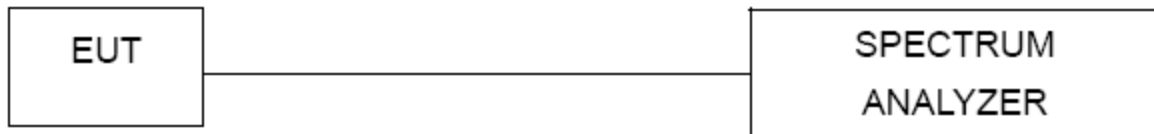

5.5 EUT OPERATION CONDITIONS

The EUT was programmed to be in continuously transmitting mode.

5.6 TEST RESULTS

Please refer to the APPENDIX E.

6. MAXIMUM OUTPUT POWER TEST**6.1 LIMIT**

FCC Part15, Subpart C (15.247)		
Section	Test Item	Limit
15.247(b)(3)	Maximum Output Power	1 Watt or 30dBm

6.2 TEST PROCEDURE

- a. The EUT was directly connected to the power meter and antenna output port as show in the block diagram below.
- b. The maximum conducted output power was performed in accordance with method 11.9.1.3 of ANSI C63.10-2013 and FCC KDB 662911 D01 v02r01 Multiple Transmitter Output.

6.3 DEVIATION FROM STANDARD

No deviation.

6.4 TEST SETUP**6.5 EUT OPERATION CONDITIONS**

The EUT was programmed to be in continuously transmitting mode.

6.6 TEST RESULTS

Please refer to the APPENDIX F.

7. CONDUCTED SPURIOUS EMISSIONS

7.1 LIMIT

In any 100 kHz bandwidth outside the frequency band in which the spread spectrum or digitally modulated intentional radiator is operating, the radio frequency power that is produced by the intentional radiator shall be at least 20 dB below that in the 100 kHz bandwidth within the band that contains the highest level of the desired power, based on either an RF conducted or a radiated measurement, provided the transmitter demonstrates compliance with the peak Output Power limits. If the transmitter complies with the Output Power limits based on the use of RMS averaging over a time interval, as permitted under paragraph (b)(3) of this section, the attenuation required under this paragraph shall be 30 dB instead of 20 dB. Attenuation below the general limits specified in Section 15.209(a) is not required.

7.2 TEST PROCEDURE

- a. The EUT was directly connected to the spectrum analyzer and antenna output port as show in the block diagram below.
- b. Spectrum Setting: RBW= 100 kHz, VBW=300 kHz, Sweep time = Auto.

7.3 DEVIATION FROM STANDARD

No deviation.

7.4 TEST SETUP



7.5 EUT OPERATION CONDITIONS

The EUT was programmed to be in continuously transmitting mode.

7.6 TEST RESULTS

Please refer to the APPENDIX G.

8. POWER SPECTRAL DENSITY TEST

8.1 LIMIT

FCC Part15, Subpart C (15.247)		
Section	Test Item	Limit
15.247(e)	Power Spectral Density	8 dBm (in any 3 kHz)

8.2 TEST PROCEDURE

- a. The EUT was directly connected to the spectrum analyzer and antenna output port as show in the block diagram below.
- b. Spectrum Setting: RBW=3 kHz, VBW=10 kHz, Sweep time = Auto.
- c. The Power Spectral Density was performed in accordance with method 11.10.2 of ANSI C63.10-2013.

8.3 DEVIATION FROM STANDARD

No deviation.

8.4 TEST SETUP



8.5 EUT OPERATION CONDITIONS

The EUT was programmed to be in continuously transmitting mode.

8.6 TEST RESULTS

Please refer to the APPENDIX H.

9. MEASUREMENT INSTRUMENTS LIST

AC Power Line Conducted Emissions					
Item	Kind of Equipment	Manufacturer	Type No.	Serial No.	Calibrated until
1	EMI Test Receiver	R&S	ESCI	100382	Mar. 10, 2020
2	LISN	EMCO	3816/2	52765	Mar. 10, 2020
3	50ohm Terminator	SHX	TF5-3	15041305	Mar. 10, 2020
4	TWO-LINE V-NETWORK	R&S	ENV216	101447	May 19, 2020
5	Measurement Software	Farad	EZ-EMC Ver.NB-03A1-01	N/A	N/A
6	Cable	N/A	RG223	12m	Mar. 12, 2020

Radiated Emissions - 9 kHz to 30 MHz					
Item	Kind of Equipment	Manufacturer	Type No.	Serial No.	Calibrated until
1	Loop Antenna	EM	EM-6876-1	230	Jan. 15, 2020
2	Cable	N/A	RG 213/U	C-102	May 31, 2020
3	EMI Test Receiver	R&S	ESCI	100895	Mar. 10, 2020
4	Measurement Software	Farad	EZ-EMC Ver.NB-03A1-01	N/A	N/A

Radiated Emissions - 30 MHz to 1 GHz					
Item	Kind of Equipment	Manufacturer	Type No.	Serial No.	Calibrated until
1	Antenna	Schwarzbeck	VULB9160	9160-3232	Mar. 09, 2020
2*	Amplifier*	HP	8447D	2944A09673	Aug. 11, 2021
3	Receiver	Agilent	N9038A	MY52130039	Aug. 03, 2020
4	Cable	emci	LMR-400(30MHz- 1GHz)(8m+5m)	N/A	May 24, 2020
5	Controller	CT	SC100	N/A	N/A
6	Controller	MF	MF-7802	MF780208416	N/A
7	Measurement Software	Farad	EZ-EMC Ver.NB-03A1-01	N/A	N/A

Radiated Emissions - Above 1 GHz					
Item	Kind of Equipment	Manufacturer	Type No.	Serial No.	Calibrated until
1	Double Ridged Guide Antenna	ETS	3115	75789	Mar. 09, 2020
2	Broad-Band Horn Antenna	Schwarzbeck	BBHA 9170	9170319	Jun. 23, 2020
3	Amplifier	Agilent	8449B	3008A02333	Mar. 10, 2020
4	Microwave Preamplifier With Adaptor	EMC INSTRUMENT	EMC2654045	980039 & HA01	Mar. 10, 2020
5	Receiver	Agilent	N9038A	MY52130039	Aug. 03, 2020
6	Controller	CT	SC100	N/A	N/A
7	Controller	MF	MF-7802	MF780208416	N/A
8	Cable	mitron	B10-01-01-12M	18072744	Jun. 29, 2020
9	Measurement Software	Farad	EZ-EMC Ver.NB-03A1-01	N/A	N/A

**Bandwidth &
Antenna Conducted Spurious Emissions &
Power Spectral Density**

Item	Kind of Equipment	Manufacturer	Type No.	Serial No.	Calibrated until
1	Spectrum Analyzer	R&S	FSP40	100185	Aug. 03, 2020

Maximum Output Power

Item	Kind of Equipment	Manufacturer	Type No.	Serial No.	Calibrated until
1	Peak Power Analyzer	Keysight	8990B	MY51000506	Aug. 03, 2020
2	Wideband power sensor	Keysight	N1923A	MY58310004	Aug. 03, 2020

Remark: "N/A" denotes no model name, serial no. or calibration specified.

"*" calibration period of equipment list is three year.

Except * item, all calibration period of equipment list is one year.

10. EUT TEST PHOTO

AC Power Line Conducted Emissions Test Photos



Radiated Emissions Test Photos**9 kHz to 30 MHz**

Radiated Emissions Test Photos

30 MHz to 1 GHz

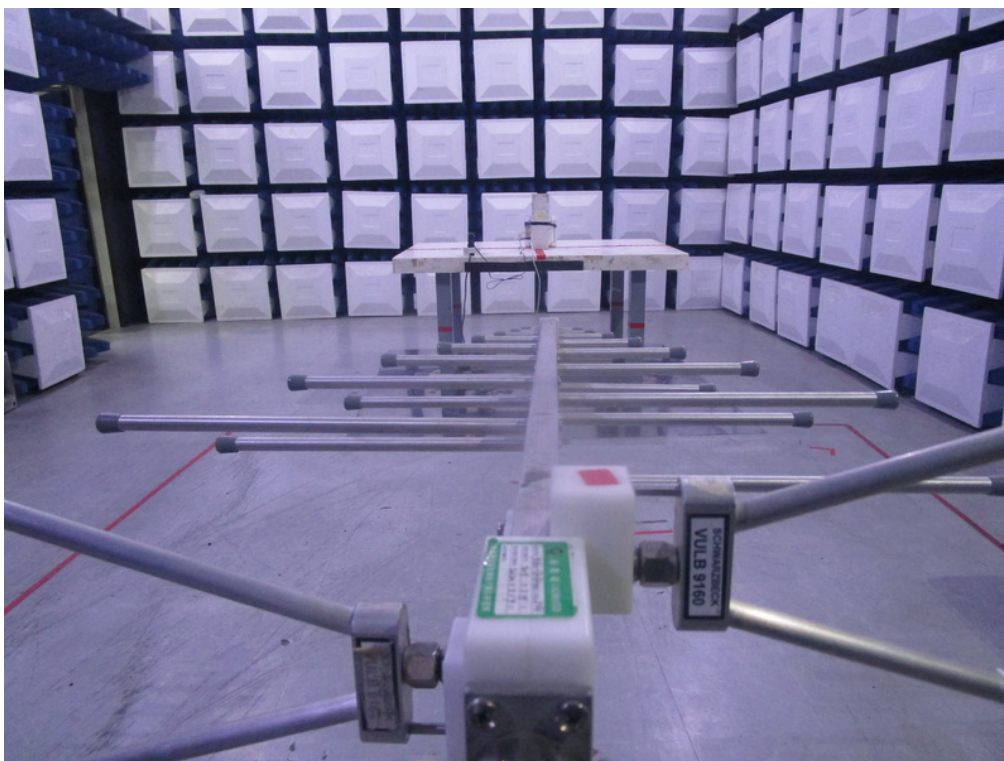
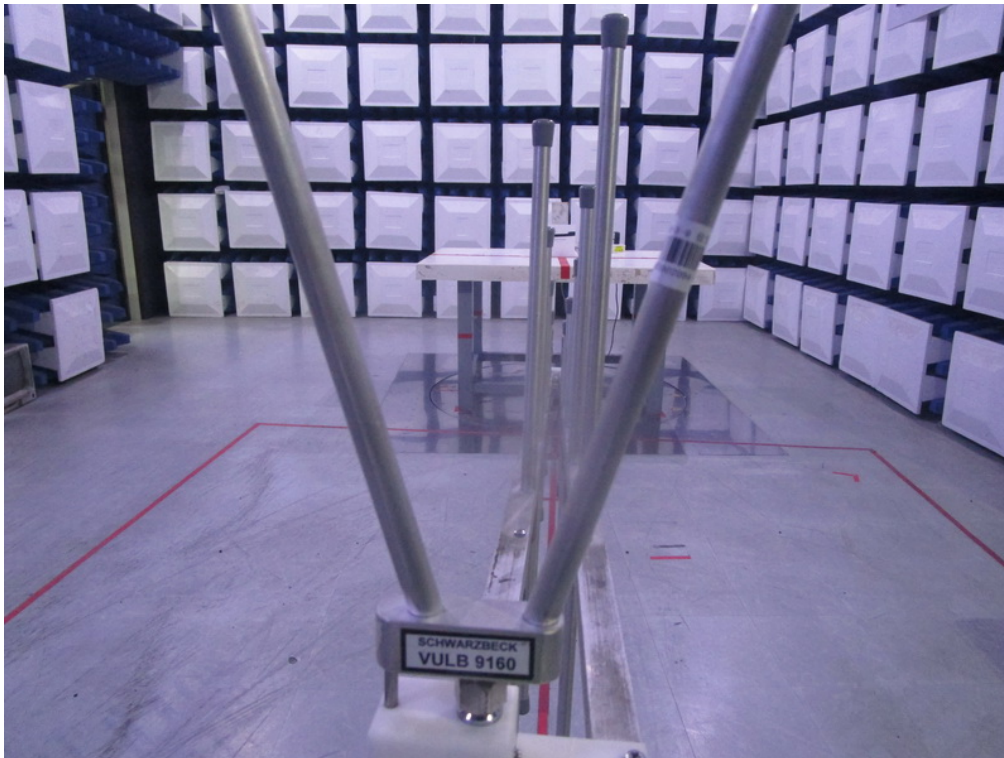

Radiated Emissions Test Photos

Above 1 GHz

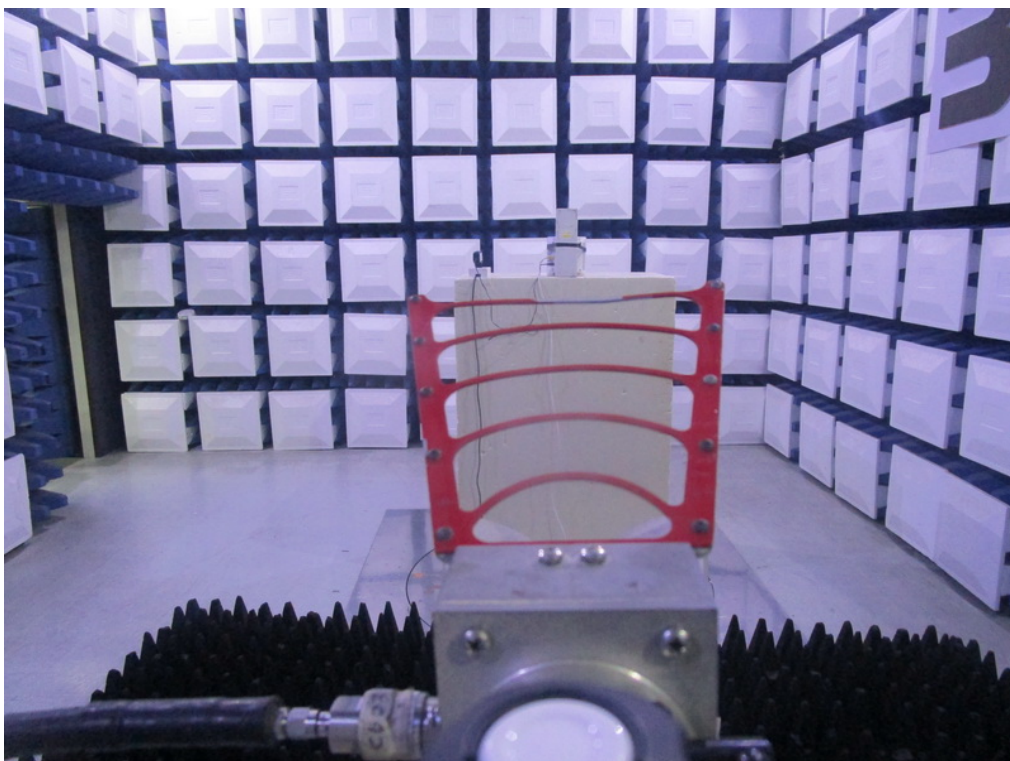
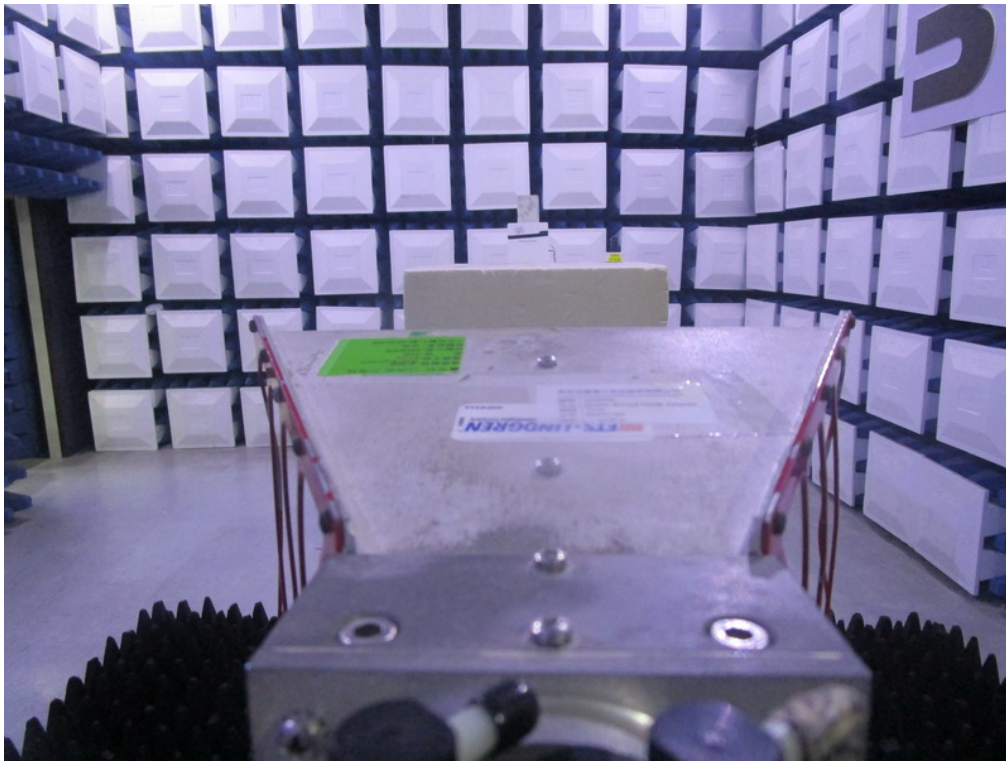

APPENDIX A - AC POWER LINE CONDUCTED EMISSIONS

Test Mode: TX N20 MODE CHANNEL 11

Line

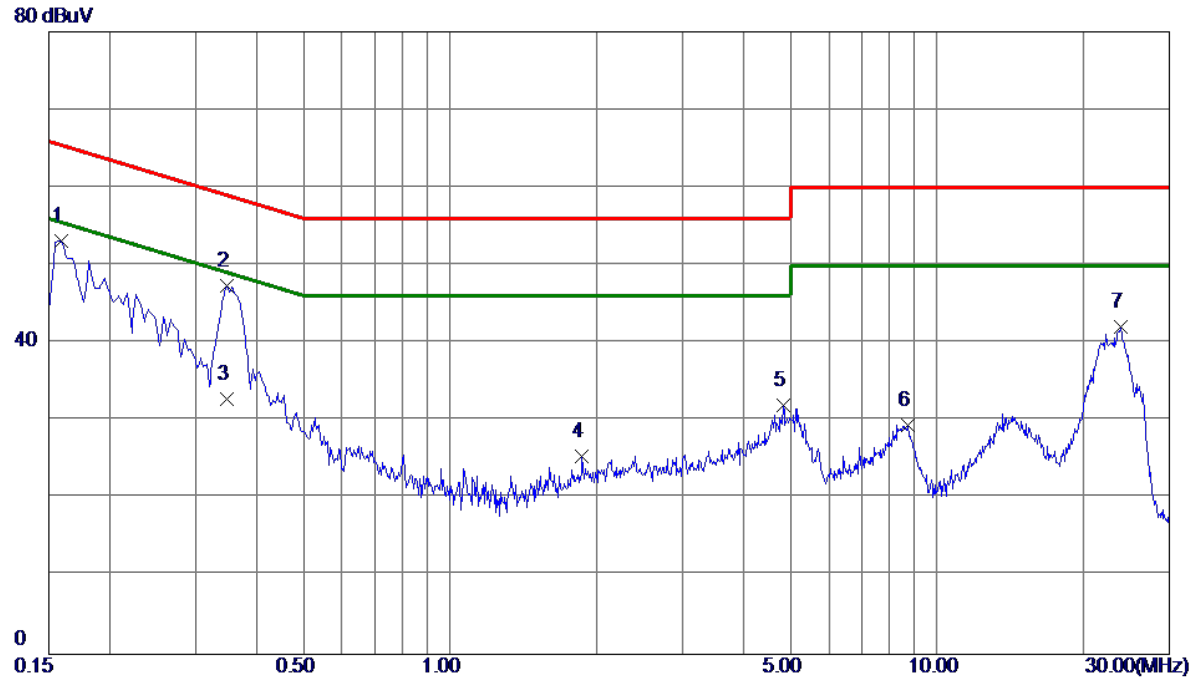

No.	Freq. MHz	Reading Level dBuV	Correct Factor dB	Measure ment dBuV	Limit dBuV	Margin dB	Detector	Comment
1	0.1590	43.34	9.82	53.16	65.52	-12.36	Peak	
2 *	0.3480	37.58	9.85	47.43	59.01	-11.58	Peak	
3	0.3480	22.90	9.85	32.75	49.01	-16.26	AVG	
4	1.8690	15.45	9.99	25.44	56.00	-30.56	Peak	
5	4.8255	21.78	10.18	31.96	56.00	-24.04	Peak	
6	8.6955	19.09	10.42	29.51	60.00	-30.49	Peak	
7	23.8785	30.93	11.14	42.07	60.00	-17.93	Peak	

REMARKS:

- (1) Measurement Value = Reading Level + Correct Factor.
- (2) Margin Level = Measurement Value - Limit Value.

Test Mode: TX N20 MODE CHANNEL 11

Neutral

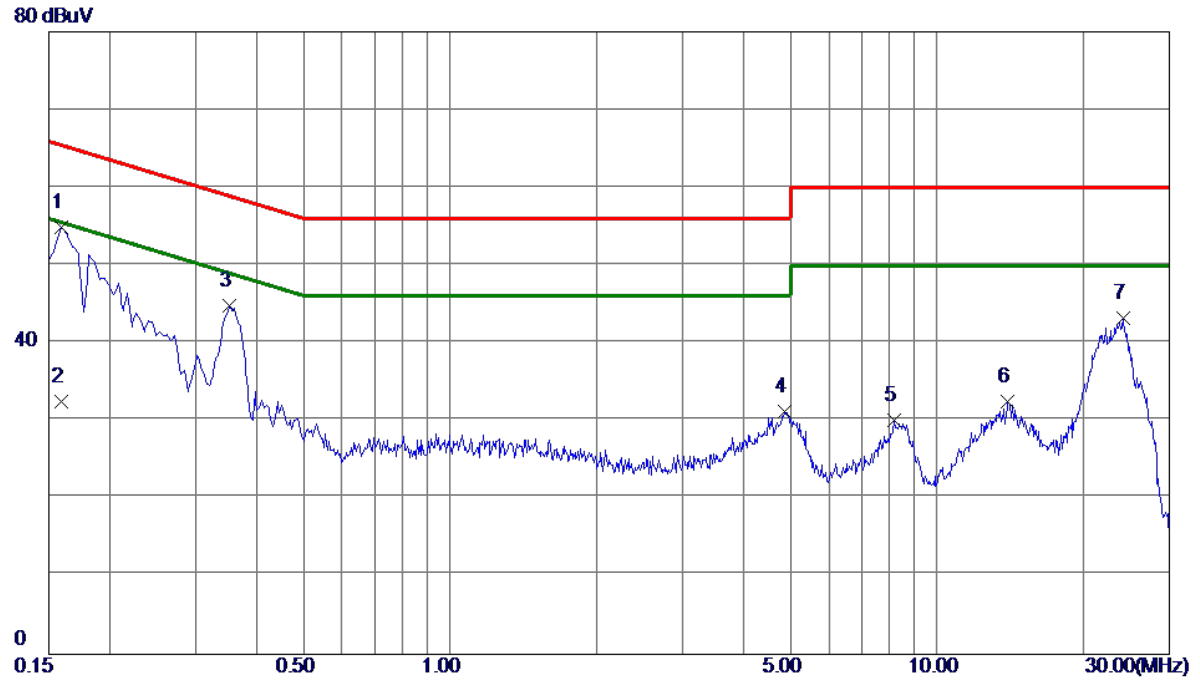

No.	Freq. MHz	Reading Level dBuV	Correct Factor dB	Measure ment dBuV	Limit dBuV	Margin dB	Detector	Comment
1 *	0.1590	44.91	9.91	54.82	65.52	-10.70	Peak	
2	0.1590	22.60	9.91	32.51	55.52	-23.01	AVG	
3	0.3525	34.74	9.99	44.73	58.90	-14.17	Peak	
4	4.8570	20.88	10.39	31.27	56.00	-24.73	Peak	
5	8.1915	19.44	10.65	30.09	60.00	-29.91	Peak	
6	13.9965	21.47	11.01	32.48	60.00	-27.52	Peak	
7	24.0630	31.78	11.48	43.26	60.00	-16.74	Peak	

REMARKS:

- (1) Measurement Value = Reading Level + Correct Factor.
- (2) Margin Level = Measurement Value - Limit Value.

APPENDIX B - RADIATED EMISSION - 9 KHZ TO 30 MHZ

Test Mode: TX N20 MODE CHANNEL 11

Ant 0°

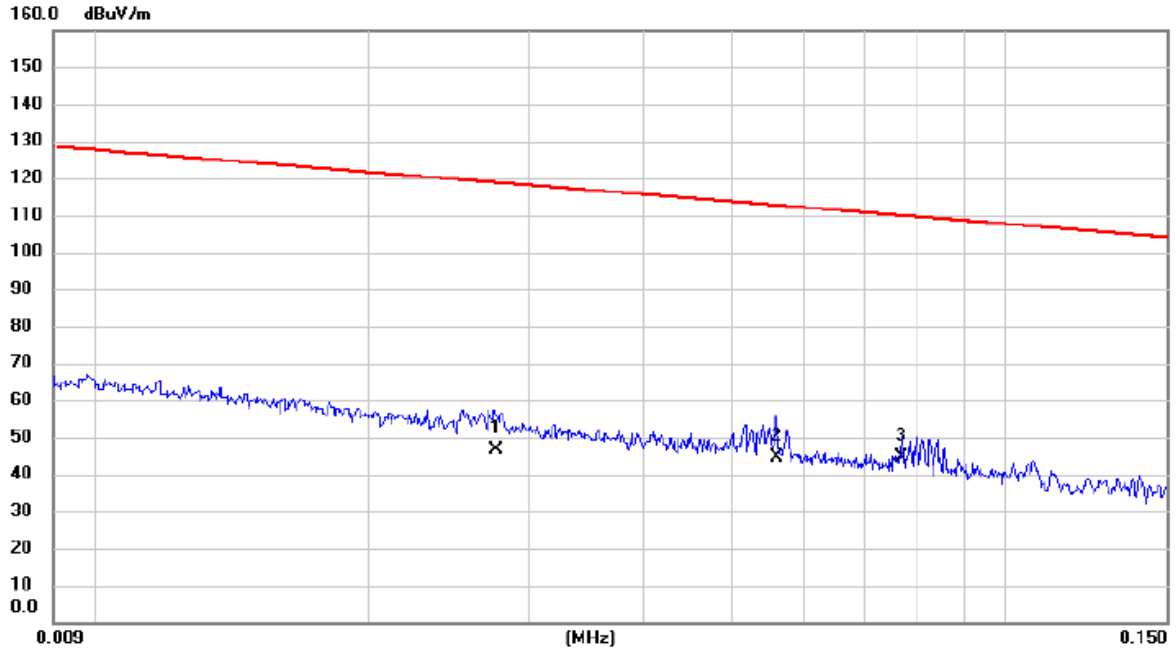

No.	Mk.	Freq. MHz	Reading Level dBuV	Correct Factor dB	Measure- ment dBuV/m	Limit dBuV/m	Margin dB	Detector	Comment
1		0.0276	32.60	13.85	46.45	118.79	-72.34	AVG	
2		0.0560	30.81	13.83	44.64	112.64	-68.00	AVG	
3	*	0.0768	31.20	13.53	44.73	109.90	-65.17	AVG	

REMARKS:
 (1) Measurement Value = Reading Level + Correct Factor.
 (2) Margin Level = Measurement Value - Limit Value.

Test Mode: TX N20 MODE CHANNEL 11

Ant 0°

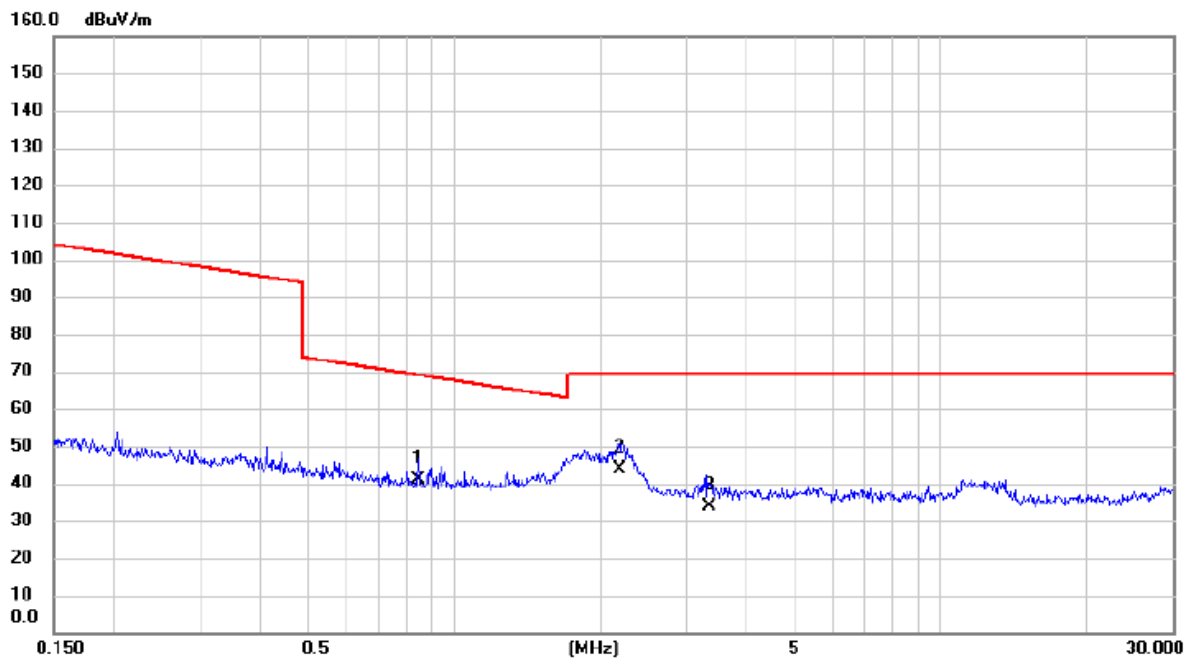

No.	Mk.	Freq. MHz	Reading Level dBuV	Correct Factor dB	Measure- ment dBuV/m	Limit dBuV/m	Margin dB	Detector	Comment
1		0.8438	28.30	12.55	40.85	69.08	-28.23	QP	
2	*	2.1898	32.10	11.71	43.81	69.54	-25.73	QP	
3		3.3458	22.80	11.14	33.94	69.54	-35.60	QP	

REMARKS:
 (1) Measurement Value = Reading Level + Correct Factor.
 (2) Margin Level = Measurement Value - Limit Value.

Test Mode: TX N20 MODE CHANNEL 11

Ant 90°

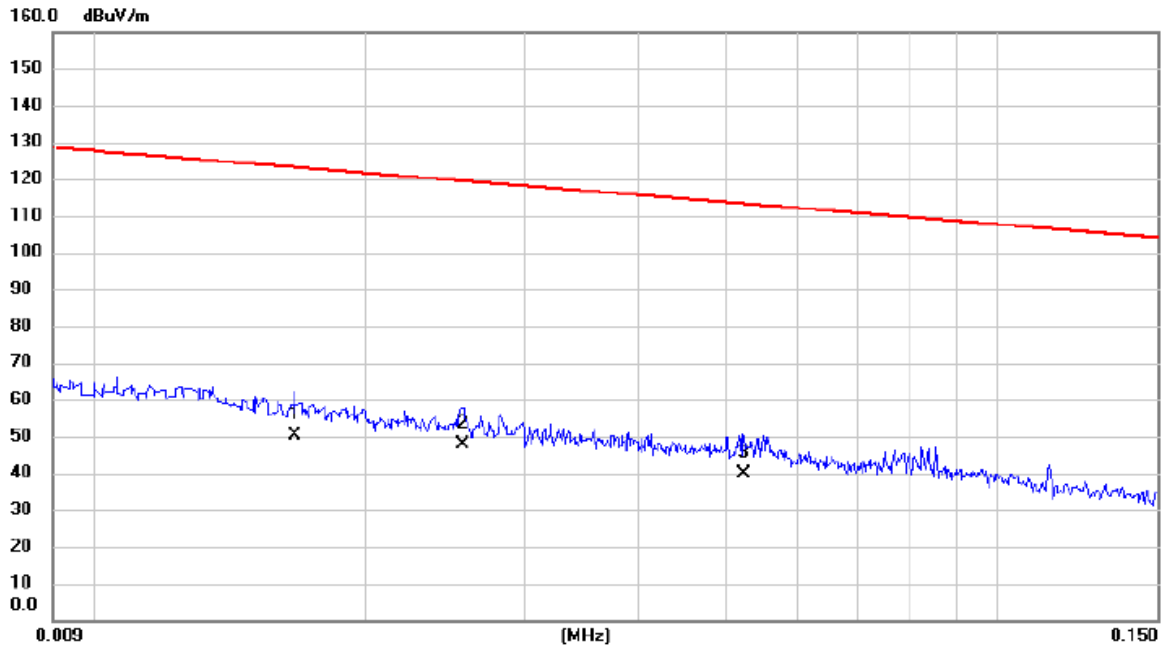

No.	Mk.	Freq. MHz	Reading Level dBuV	Correct Factor dB	Measure- ment dBuV/m	Limit dBuV/m	Margin dB	Detector	Comment
1		0.0167	35.20	14.81	50.01	123.15	-73.14	AVG	
2	*	0.0256	33.80	13.84	47.64	119.44	-71.80	AVG	
3		0.0524	26.10	13.89	39.99	113.22	-73.23	AVG	

REMARKS:

- (1) Measurement Value = Reading Level + Correct Factor.
- (2) Margin Level = Measurement Value - Limit Value.

Test Mode: TX N20 MODE CHANNEL 11

Ant 90°

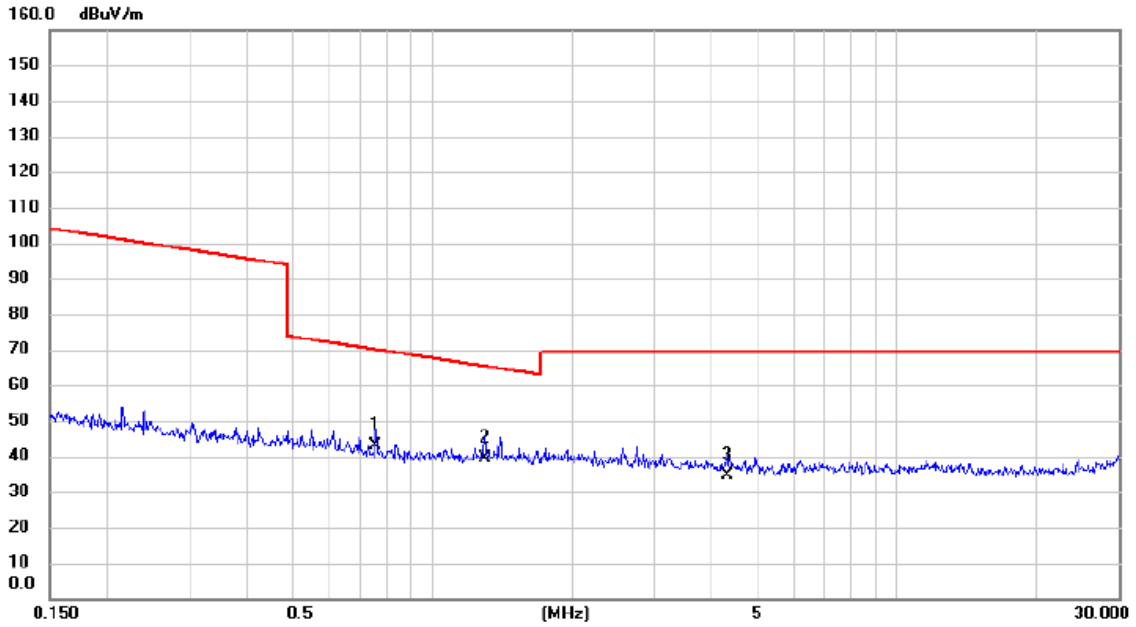

No.	Mk.	Freq. MHz	Reading Level dBuV	Correct Factor dB	Measure- ment dBuV/m	Limit dBuV/m	Margin dB	Detector	Comment
1		0.7550	30.30	12.58	42.88	70.05	-27.17	QP	
2	*	1.2960	27.20	12.29	39.49	65.35	-25.86	QP	
3		4.3146	23.80	10.92	34.72	69.54	-34.82	QP	

REMARKS:

- (1) Measurement Value = Reading Level + Correct Factor.
- (2) Margin Level = Measurement Value - Limit Value.

APPENDIX C - RADIATED EMISSION - 30 MHZ TO 1000 MHZ

Test Mode: TX N20 MODE CHANNEL 11

Vertical

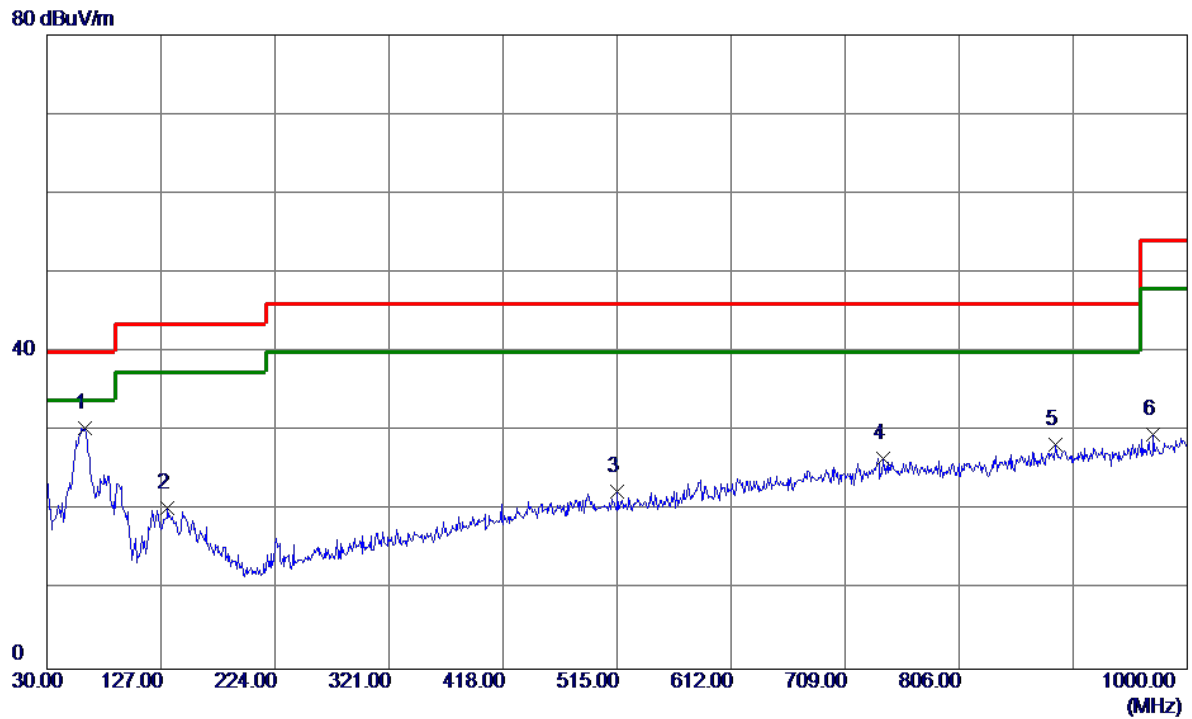

No.	Freq. MHz	Reading Level dBuV/m	Correct Factor dB	Measure ment dBuV/m	Limit dBuV/m	Margin dB	Detector	Comment
1 *	62.4950	45.38	-15.00	30.38	40.00	-9.62	Peak	
2	132.8200	33.28	-13.00	20.28	43.50	-23.22	Peak	
3	515.0000	29.89	-7.54	22.35	46.00	-23.65	Peak	
4	741.0100	30.23	-3.72	26.51	46.00	-19.49	Peak	
5	887.9650	30.39	-2.02	28.37	46.00	-17.63	Peak	
6	971.3850	29.97	-0.41	29.56	54.00	-24.44	Peak	

REMARKS:

- (1) Measurement Value = Reading Level + Correct Factor.
- (2) Margin Level = Measurement Value - Limit Value.

Test Mode: TX N20 MODE CHANNEL 11

Horizontal

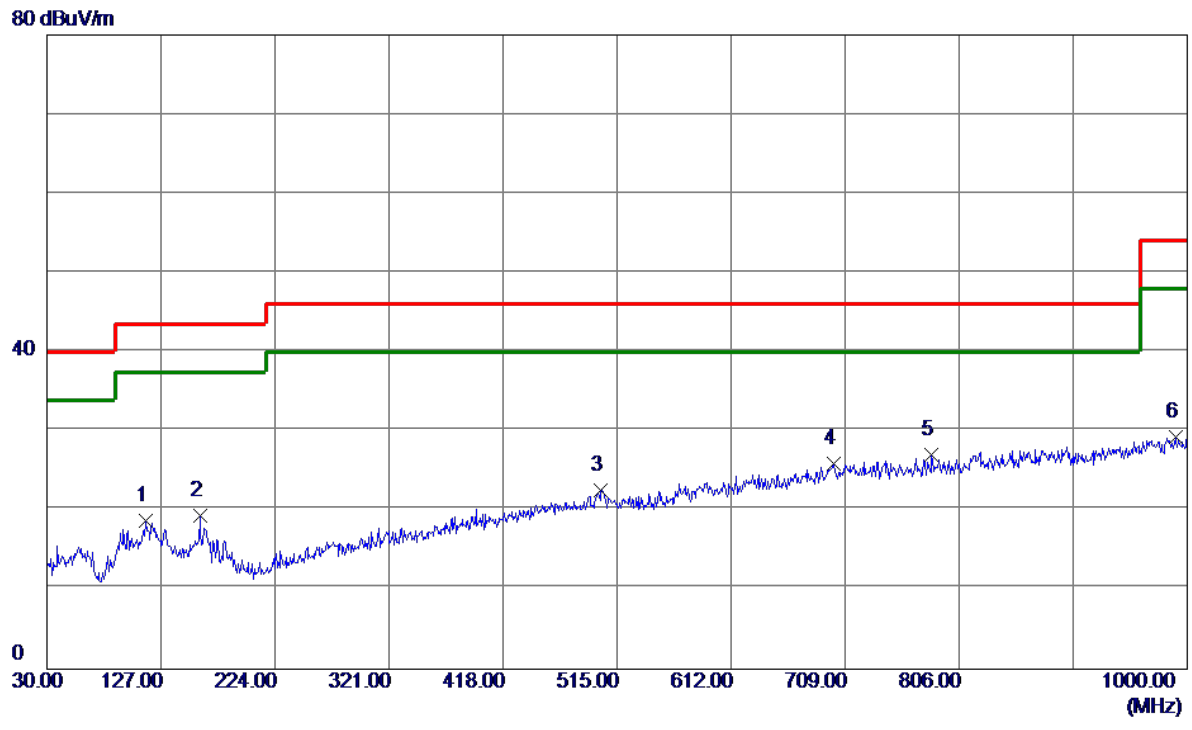

No.	Freq. MHz	Reading Level dBuV/m	Correct Factor dB	Measure ment dBuV/m	Limit dBuV/m	Margin dB	Detector	Comment
1	114.3900	32.61	-13.87	18.74	43.50	-24.76	Peak	
2	160.4650	30.42	-11.07	19.35	43.50	-24.15	Peak	
3	501.4200	30.19	-7.67	22.52	46.00	-23.48	Peak	
4	699.7849	29.94	-4.01	25.93	46.00	-20.07	Peak	
5 *	782.7199	30.31	-3.23	27.08	46.00	-18.92	Peak	
6	989.8150	29.31	-0.10	29.21	54.00	-24.79	Peak	

REMARKS:

- (1) Measurement Value = Reading Level + Correct Factor.
- (2) Margin Level = Measurement Value - Limit Value.

APPENDIX D - RADIATED EMISSION- ABOVE 1000 MHZ

Test Mode: TX B Mode 2412 MHz

Vertical

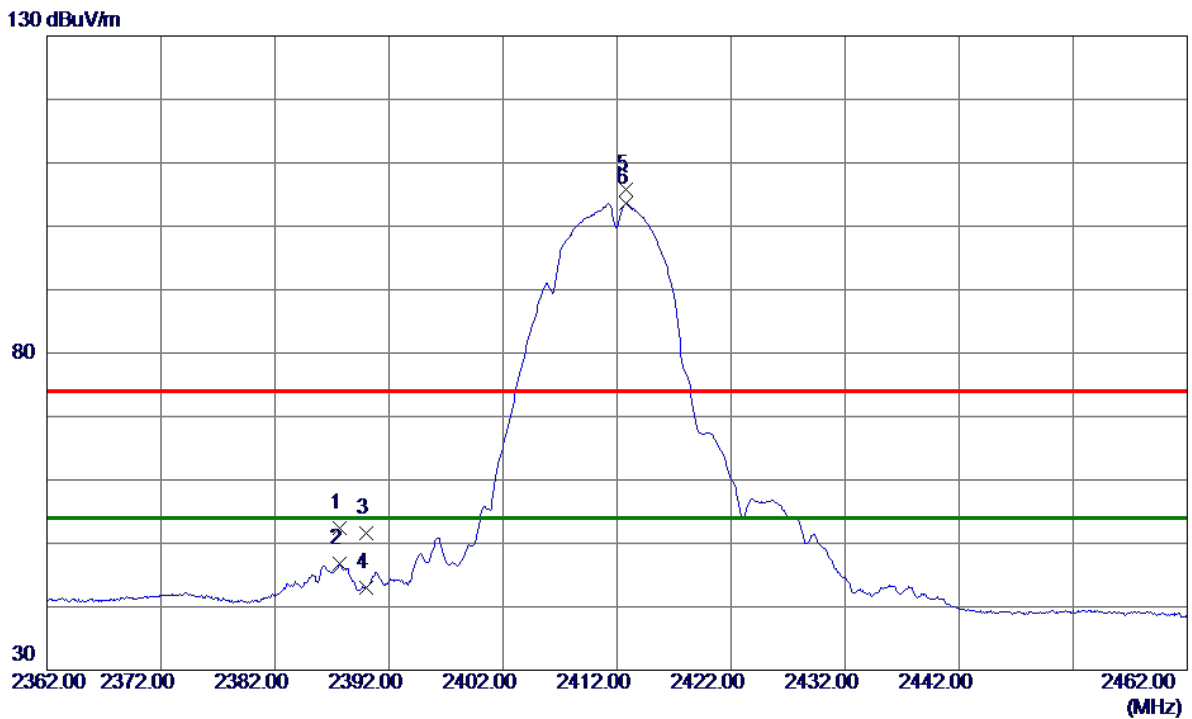

No.	Freq. MHz	Reading Level dBuV/m	Correct Factor dB	Measure ment dBuV/m	Limit dBuV/m	Margin dB	Detector	Comment
1	2387.6500	46.08	6.24	52.32	74.00	-21.68	Peak	
2	2387.6500	40.47	6.24	46.71	54.00	-7.29	AVG	
3	2390.0000	45.29	6.24	51.53	74.00	-22.47	Peak	
4	2390.0000	36.85	6.24	43.09	54.00	-10.91	AVG	
5	2412.8000	99.57	6.20	105.77	74.00	31.77	Peak	No Limit
6 *	2412.8000	97.46	6.20	103.66	54.00	49.66	AVG	No Limit

REMARKS:

- (1) Measurement Value = Reading Level + Correct Factor.
- (2) Margin Level = Measurement Value - Limit Value.

Test Mode: TX B Mode 2412 MHz

Vertical

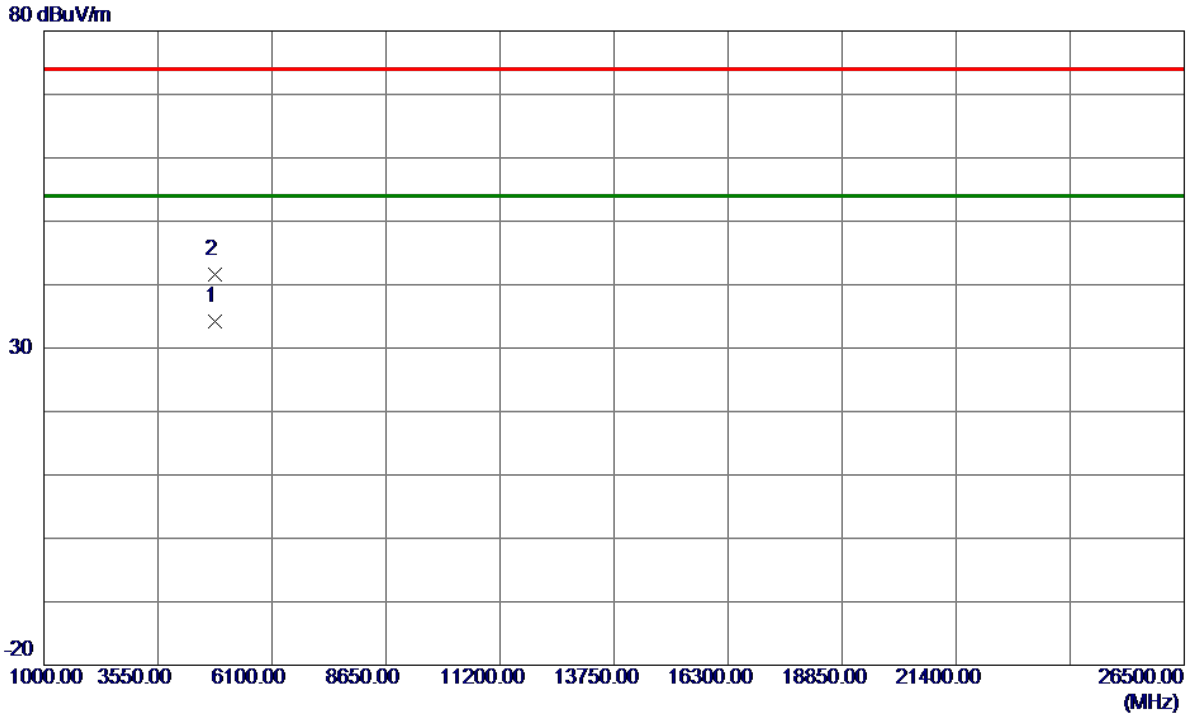

No.	Freq. MHz	Reading Level dBuV/m	Correct Factor dB	Measure ment dBuV/m	Limit dBuV/m	Margin dB	Detector	Comment
1 *	4823.9370	31.67	2.49	34.16	54.00	-19.84	AVG	
2	4823.9660	39.04	2.49	41.53	74.00	-32.47	Peak	

REMARKS:

- (1) Measurement Value = Reading Level + Correct Factor.
- (2) Margin Level = Measurement Value - Limit Value.

Test Mode: TX B Mode 2412 MHz

Horizontal

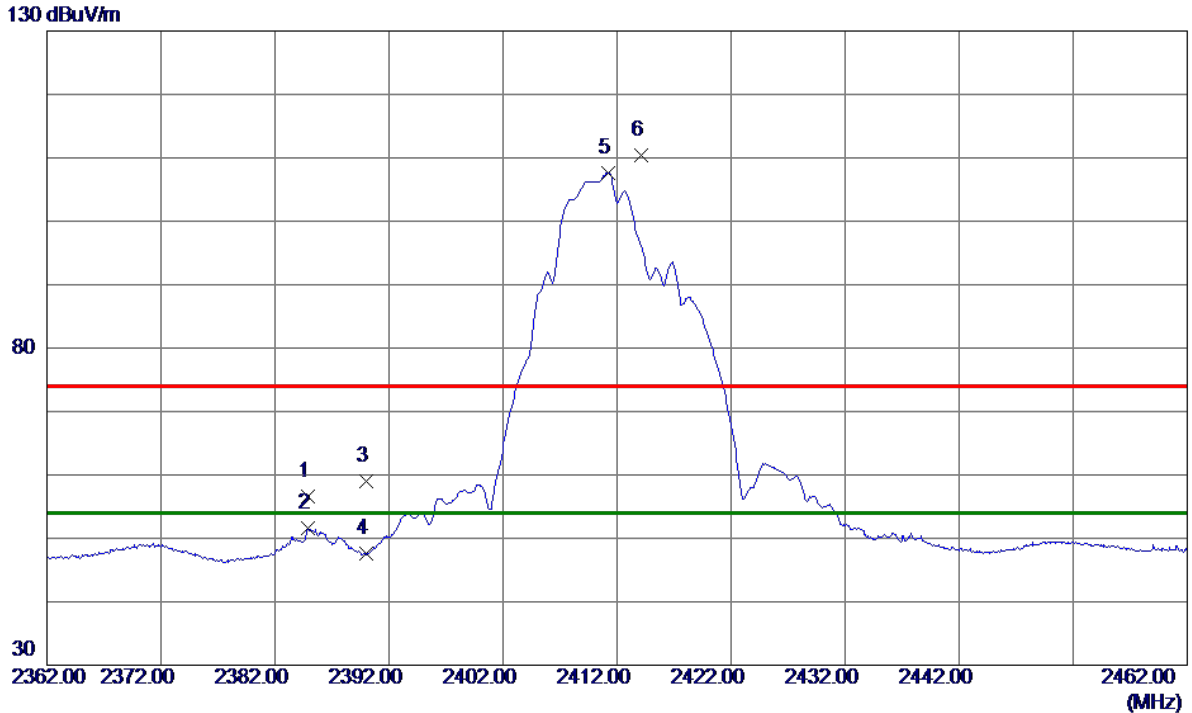

No.	Freq. MHz	Reading Level dBuV/m	Correct Factor dB	Measure ment dBuV/m	Limit dBuV/m	Margin dB	Detector	Comment
1	2384.8500	50.34	6.25	56.59	74.00	-17.41	Peak	
2	2384.8500	45.34	6.25	51.59	54.00	-2.41	AVG	
3	2390.0000	52.85	6.24	59.09	74.00	-14.91	Peak	
4	2390.0000	41.35	6.24	47.59	54.00	-6.41	AVG	
5 *	2411.2000	101.37	6.20	107.57	54.00	53.57	AVG	No Limit
6	2414.1000	104.26	6.20	110.46	74.00	36.46	Peak	No Limit

REMARKS:
 (1) Measurement Value = Reading Level + Correct Factor.
 (2) Margin Level = Measurement Value - Limit Value.

Test Mode: TX B Mode 2412 MHz

Horizontal

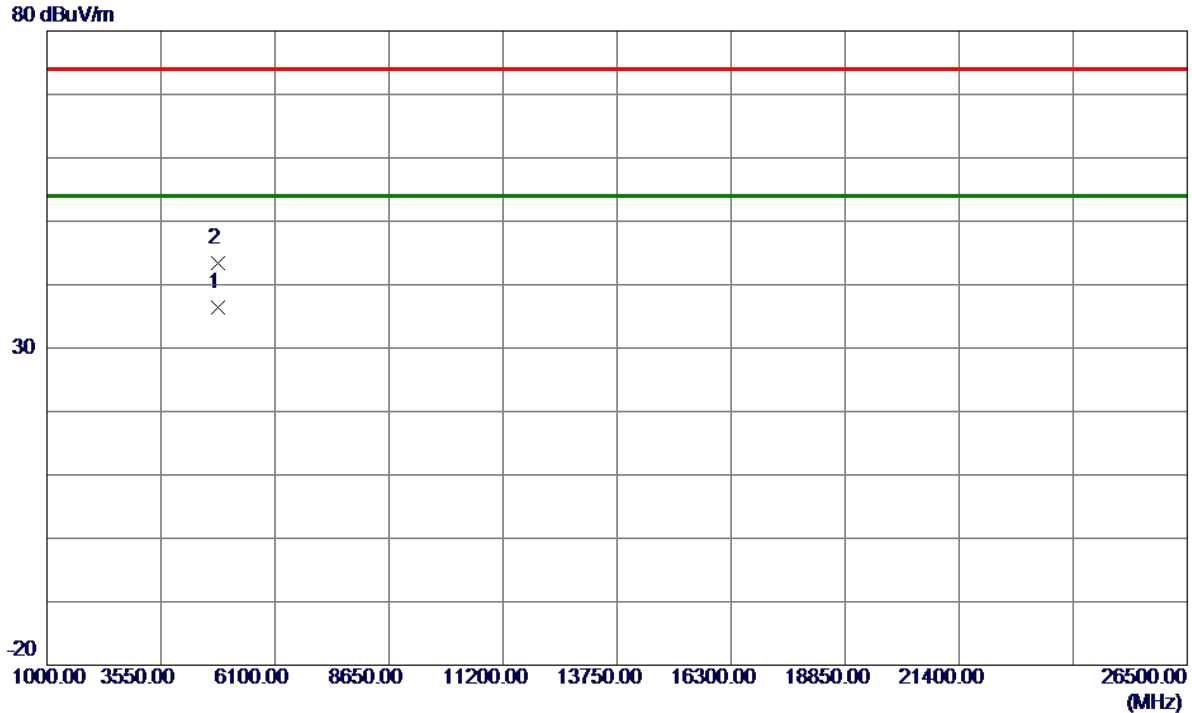

No.	Freq. MHz	Reading Level dBuV/m	Correct Factor dB	Measure ment dBuV/m	Limit dBuV/m	Margin dB	Detector	Comment
1 *	4823.9110	34.00	2.49	36.49	54.00	-17.51	AVG	
2	4824.0179	40.90	2.50	43.40	74.00	-30.60	Peak	

REMARKS:
 (1) Measurement Value = Reading Level + Correct Factor.
 (2) Margin Level = Measurement Value - Limit Value.

Test Mode: TX B Mode 2437 MHz

Vertical

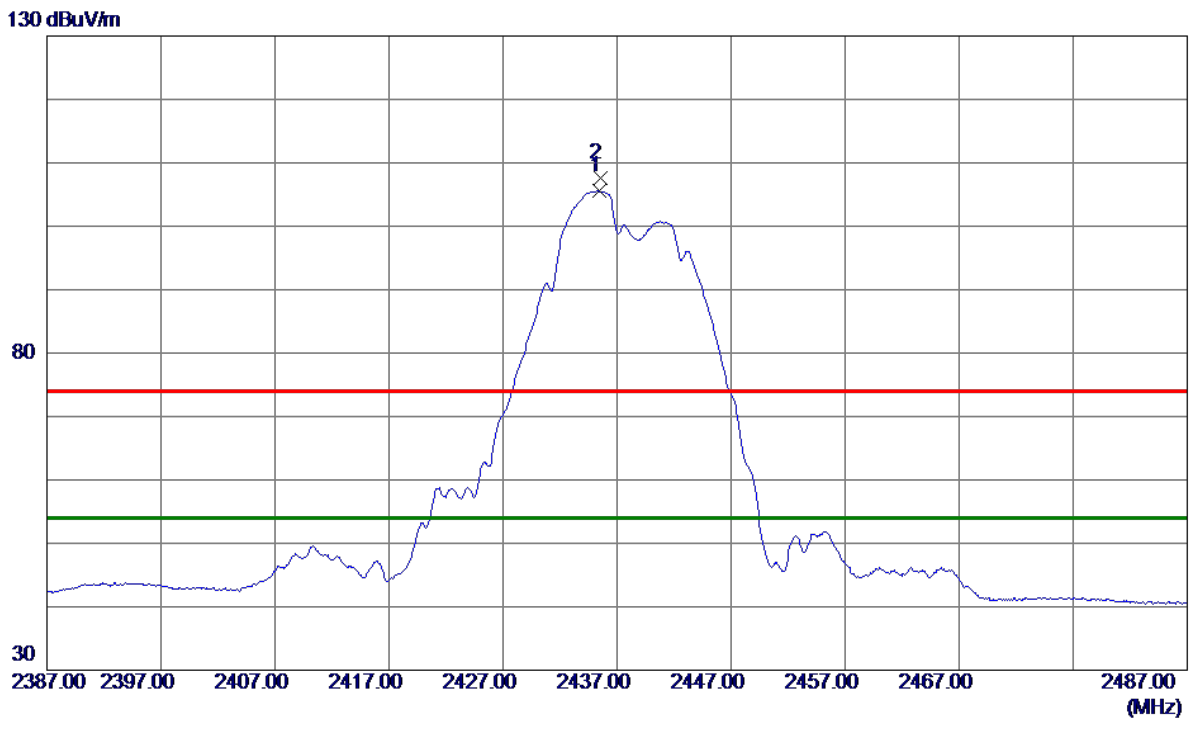

No.	Freq. MHz	Reading Level dBuV/m	Correct Factor dB	Measure ment dBuV/m	Limit dBuV/m	Margin dB	Detector	Comment
1 *	2435.4000	99.46	6.16	105.62	54.00	51.62	AVG	No Limit
2	2435.5000	101.42	6.16	107.58	74.00	33.58	Peak	No Limit

REMARKS:

- (1) Measurement Value = Reading Level + Correct Factor.
- (2) Margin Level = Measurement Value - Limit Value.

Test Mode: TX B Mode 2437 MHz

Vertical



No.	Freq. MHz	Reading Level dBuV/m	Correct Factor dB	Measure ment dBuV/m	Limit dBuV/m	Margin dB	Detector	Comment
1	4873.9400	42.80	2.66	45.46	74.00	-28.54	Peak	
2 *	4873.9930	37.84	2.66	40.50	54.00	-13.50	AVG	

REMARKS:

- (1) Measurement Value = Reading Level + Correct Factor.
- (2) Margin Level = Measurement Value - Limit Value.

Test Mode: TX B Mode 2437 MHz

Horizontal

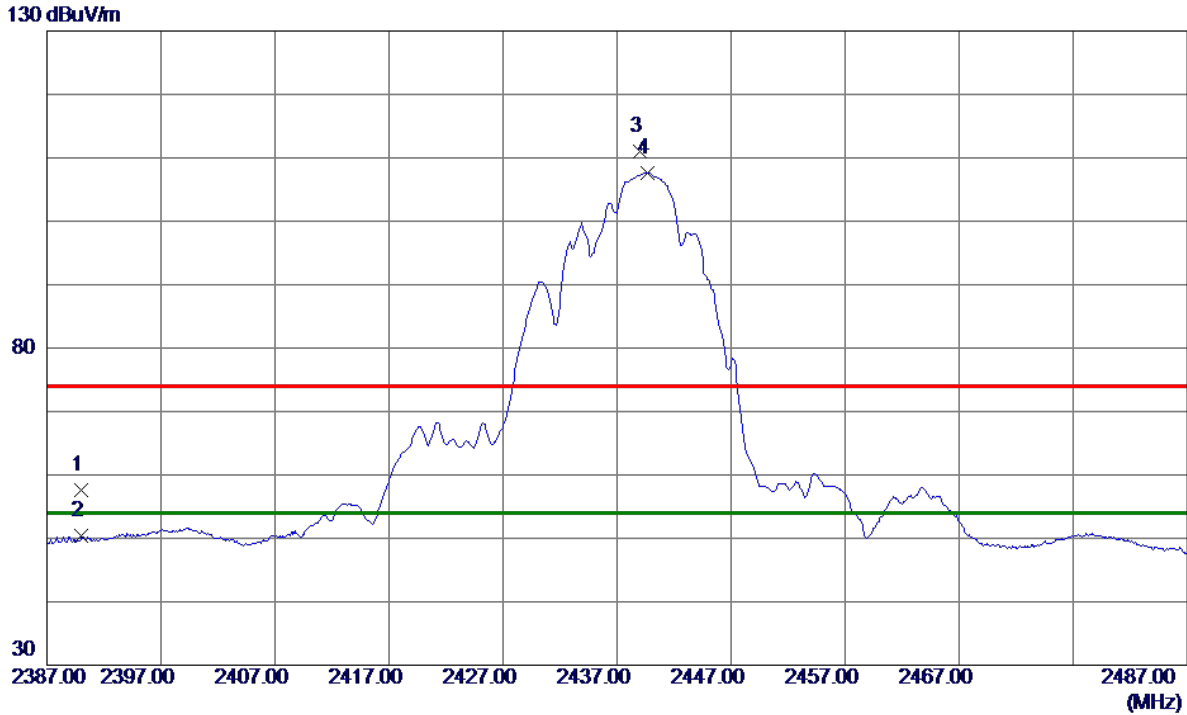

No.	Freq. MHz	Reading Level dBuV/m	Correct Factor dB	Measure ment dBuV/m	Limit dBuV/m	Margin dB	Detector	Comment
1	2390.0000	51.40	6.24	57.64	74.00	-16.36	Peak	
2	2390.0000	44.21	6.24	50.45	54.00	-3.55	AVG	
3	2439.0500	104.92	6.16	111.08	74.00	37.08	Peak	No Limit
4 *	2439.6500	101.52	6.15	107.67	54.00	53.67	AVG	No Limit

REMARKS:

(1) Measurement Value = Reading Level + Correct Factor.

(2) Margin Level = Measurement Value - Limit Value.

Test Mode: TX B Mode 2437 MHz

Horizontal

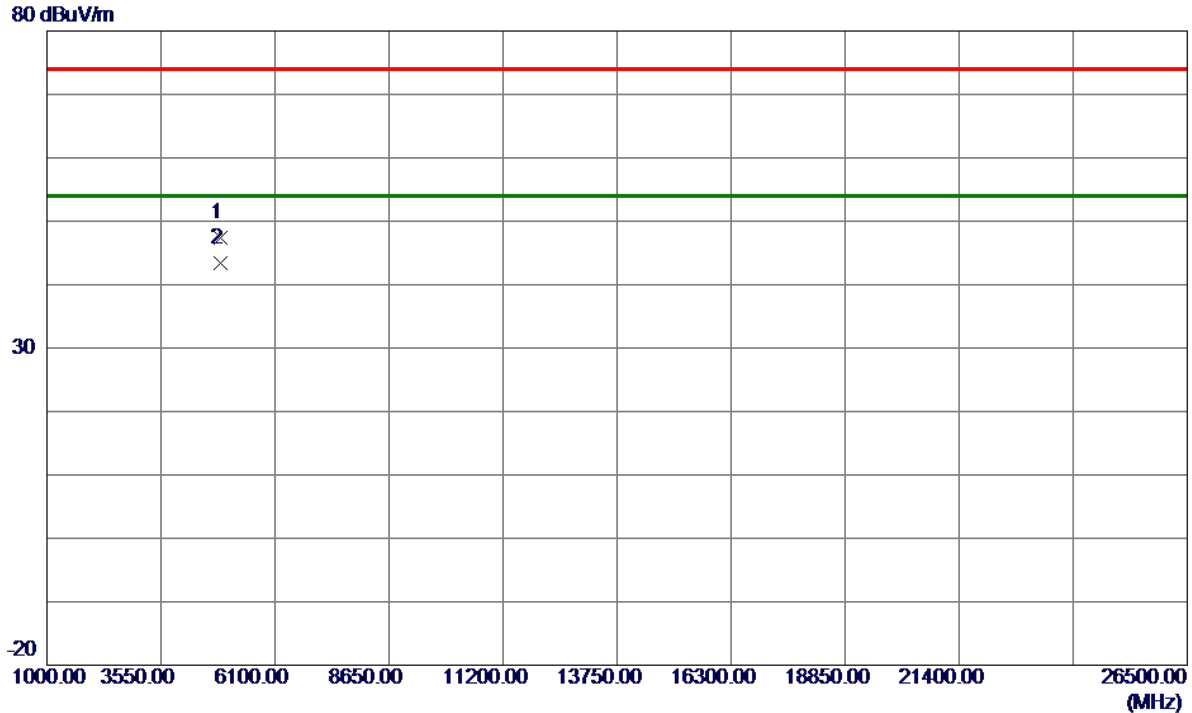

No.	Freq. MHz	Reading Level dBuV/m	Correct Factor dB	Measure ment dBuV/m	Limit dBuV/m	Margin dB	Detector	Comment
1	4873.9770	44.67	2.66	47.33	74.00	-26.67	Peak	
2 *	4873.9940	40.72	2.66	43.38	54.00	-10.62	AVG	

REMARKS:
 (1) Measurement Value = Reading Level + Correct Factor.
 (2) Margin Level = Measurement Value - Limit Value.

Test Mode: TX B Mode 2462 MHz

Vertical

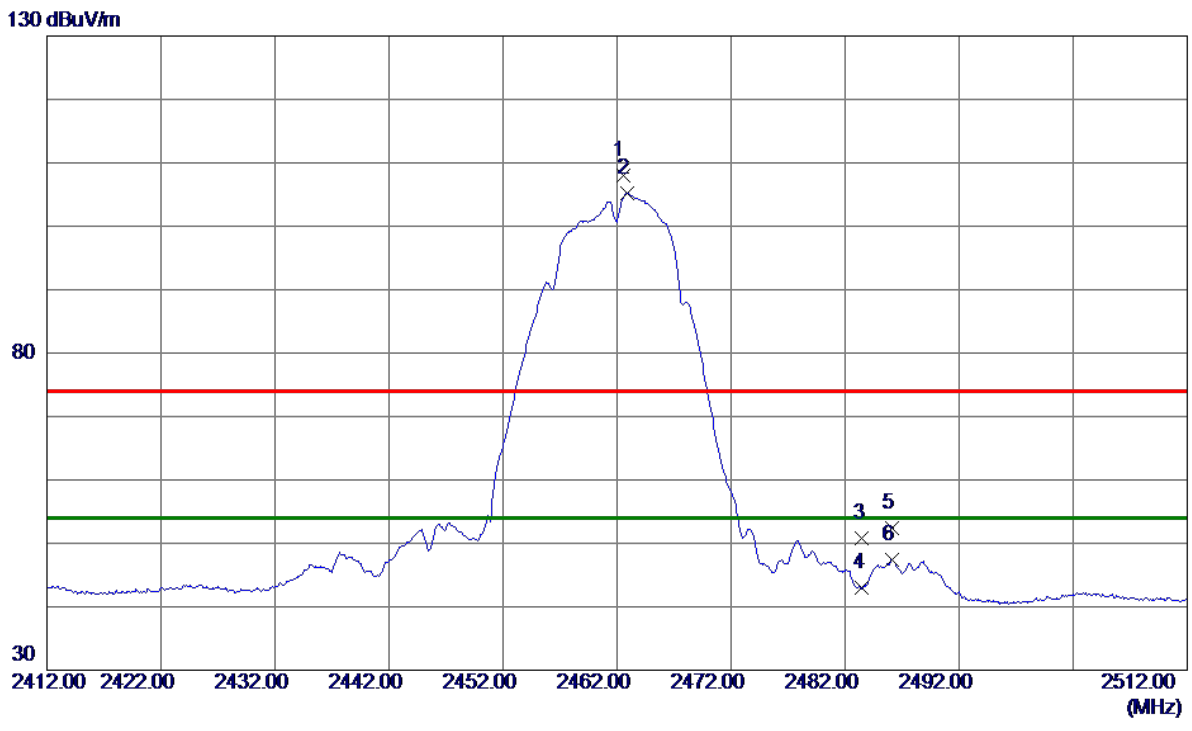

No.	Freq. MHz	Reading Level dBuV/m	Correct Factor dB	Measurement dBuV/m	Limit dBuV/m	Margin dB	Detector	Comment
1	2462.5000	101.79	6.12	107.91	74.00	33.91	Peak	No Limit
2 *	2462.8500	99.13	6.12	105.25	54.00	51.25	AVG	No Limit
3	2483.5000	44.70	6.08	50.78	74.00	-23.22	Peak	
4	2483.5000	36.89	6.08	42.97	54.00	-11.03	AVG	
5	2486.1000	46.32	6.08	52.40	74.00	-21.60	Peak	
6	2486.1000	41.32	6.08	47.40	54.00	-6.60	AVG	

REMARKS:

- (1) Measurement Value = Reading Level + Correct Factor.
- (2) Margin Level = Measurement Value - Limit Value.

Test Mode: TX B Mode 2462 MHz

Vertical

80 dBuV/m

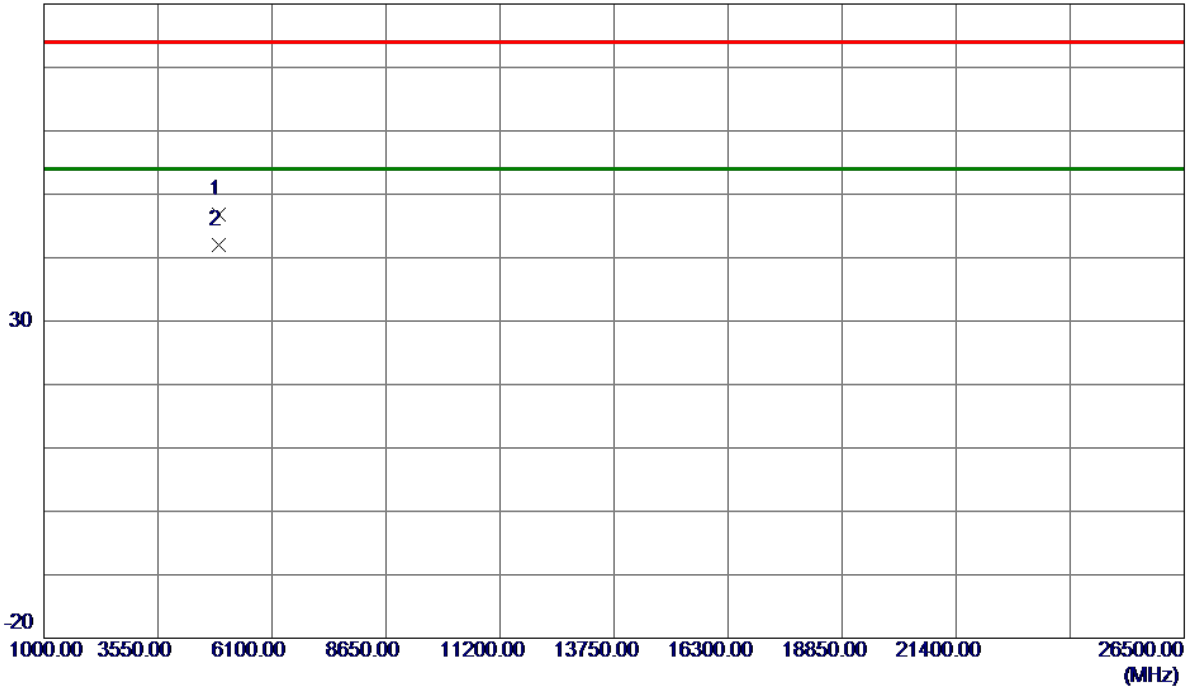

No.	Freq. MHz	Reading Level dBuV/m	Correct Factor dB	Measure ment dBuV/m	Limit dBuV/m	Margin dB	Detector	Comment
1	4923.9460	44.06	2.82	46.88	74.00	-27.12	Peak	
2 *	4923.9970	39.16	2.82	41.98	54.00	-12.02	AVG	

REMARKS:

- (1) Measurement Value = Reading Level + Correct Factor.
- (2) Margin Level = Measurement Value - Limit Value.

Test Mode: TX B Mode 2462 MHz

Horizontal

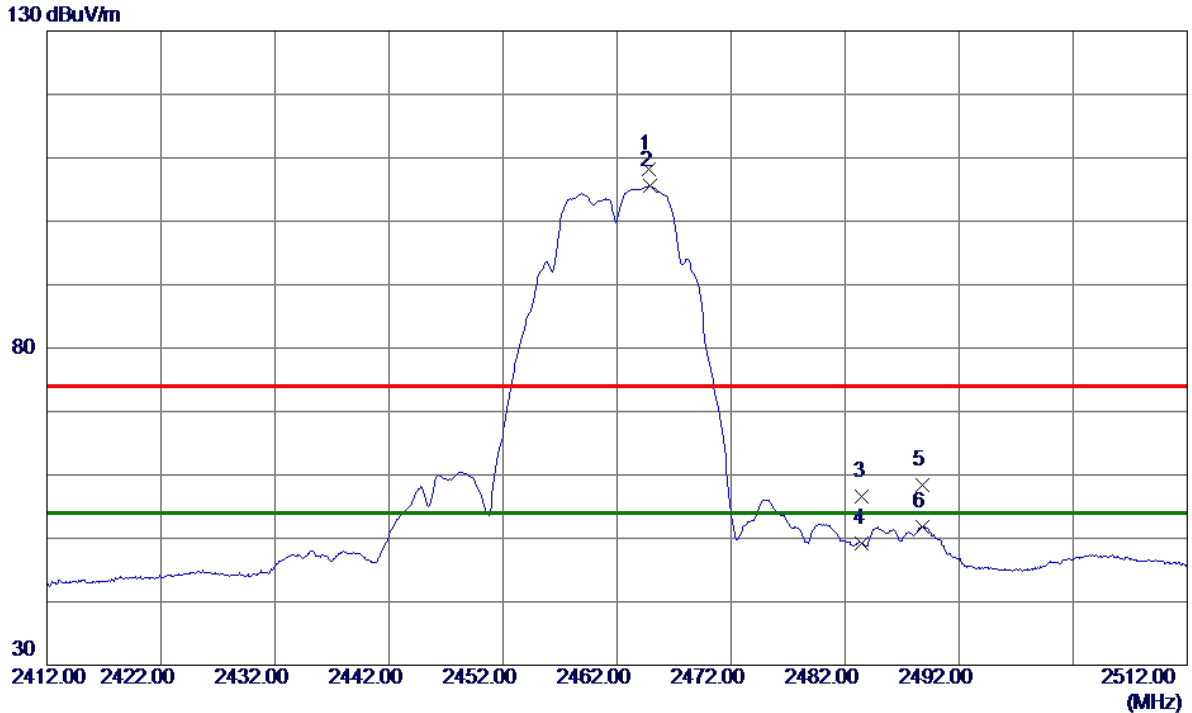

No.	Freq. MHz	Reading Level dBuV/m	Correct Factor dB	Measure ment dBuV/m	Limit dBuV/m	Margin dB	Detector	Comment
1	2464.7500	102.01	6.11	108.12	74.00	34.12	Peak	No Limit
2 *	2464.8500	99.44	6.11	105.55	54.00	51.55	AVG	No Limit
3	2483.5000	50.46	6.08	56.54	74.00	-17.46	Peak	
4	2483.5000	43.06	6.08	49.14	54.00	-4.86	AVG	
5	2488.7500	52.25	6.07	58.32	74.00	-15.68	Peak	
6	2488.7500	45.82	6.07	51.89	54.00	-2.11	AVG	

REMARKS:
 (1) Measurement Value = Reading Level + Correct Factor.
 (2) Margin Level = Measurement Value - Limit Value.

Test Mode: TX B Mode 2462 MHz

Horizontal

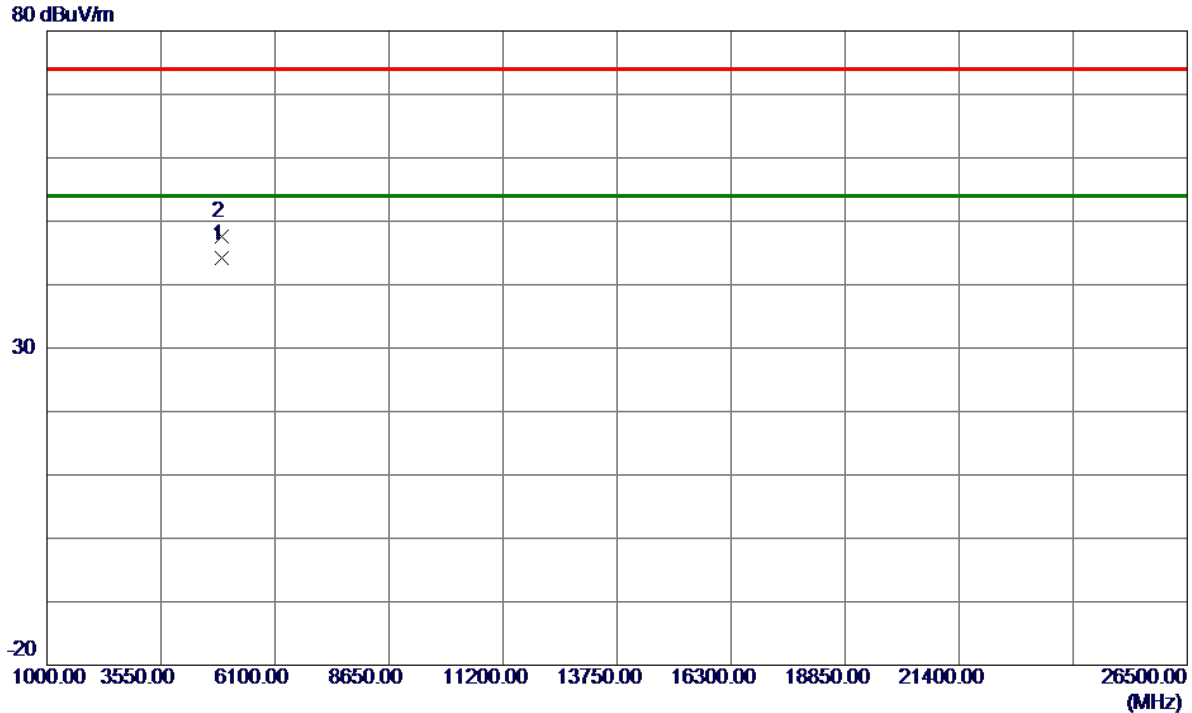

No.	Freq. MHz	Reading Level dBuV/m	Correct Factor dB	Measure ment dBuV/m	Limit dBuV/m	Margin dB	Detector	Comment
1 *	4923.9340	41.28	2.82	44.10	54.00	-9.90	AVG	
2	4924.0610	44.83	2.82	47.65	74.00	-26.35	Peak	

REMARKS:
 (1) Measurement Value = Reading Level + Correct Factor.
 (2) Margin Level = Measurement Value - Limit Value.

Test Mode: TX G Mode 2412 MHz

Vertical

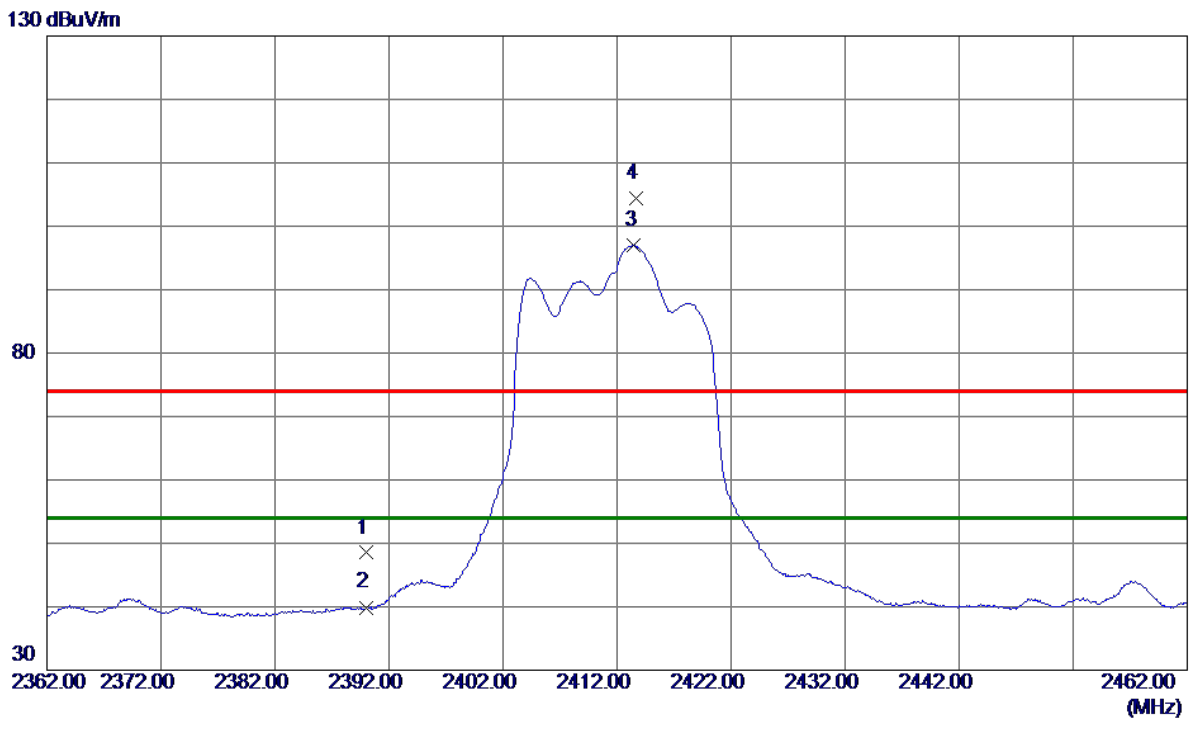

No.	Freq. MHz	Reading Level dBuV/m	Correct Factor dB	Measure ment dBuV/m	Limit dBuV/m	Margin dB	Detector	Comment
1	2390.0000	42.26	6.24	48.50	74.00	-25.50	Peak	
2	2390.0000	33.66	6.24	39.90	54.00	-14.10	AVG	
3 *	2413.5000	90.72	6.20	96.92	54.00	42.92	AVG	No Limit
4	2413.6500	98.27	6.20	104.47	74.00	30.47	Peak	No Limit

REMARKS:

- (1) Measurement Value = Reading Level + Correct Factor.
- (2) Margin Level = Measurement Value - Limit Value.

Test Mode: TX G Mode 2412 MHz

Vertical

80 dBuV/m

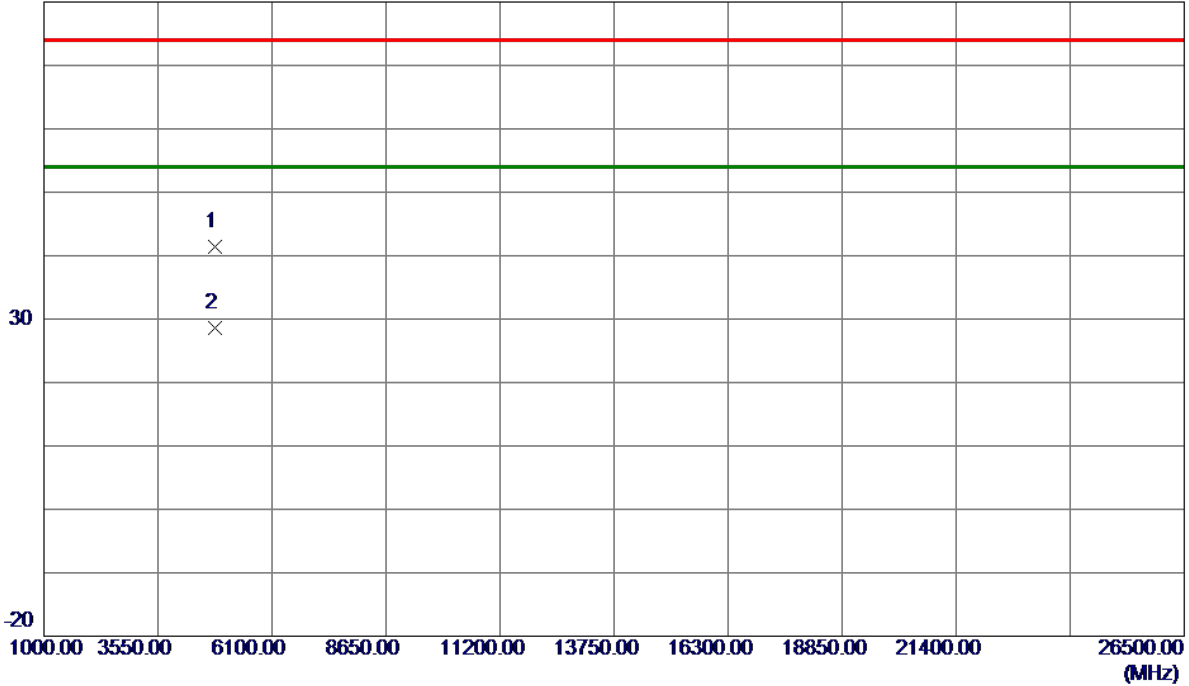

No.	Freq. MHz	Reading Level dBuV/m	Correct Factor dB	Measure ment dBuV/m	Limit dBuV/m	Margin dB	Detector	Comment
1	4823.9720	38.89	2.49	41.38	74.00	-32.62	Peak	
2 *	4824.7430	26.05	2.50	28.55	54.00	-25.45	AVG	

REMARKS:

- (1) Measurement Value = Reading Level + Correct Factor.
- (2) Margin Level = Measurement Value - Limit Value.

Test Mode: TX G Mode 2412 MHz

Horizontal

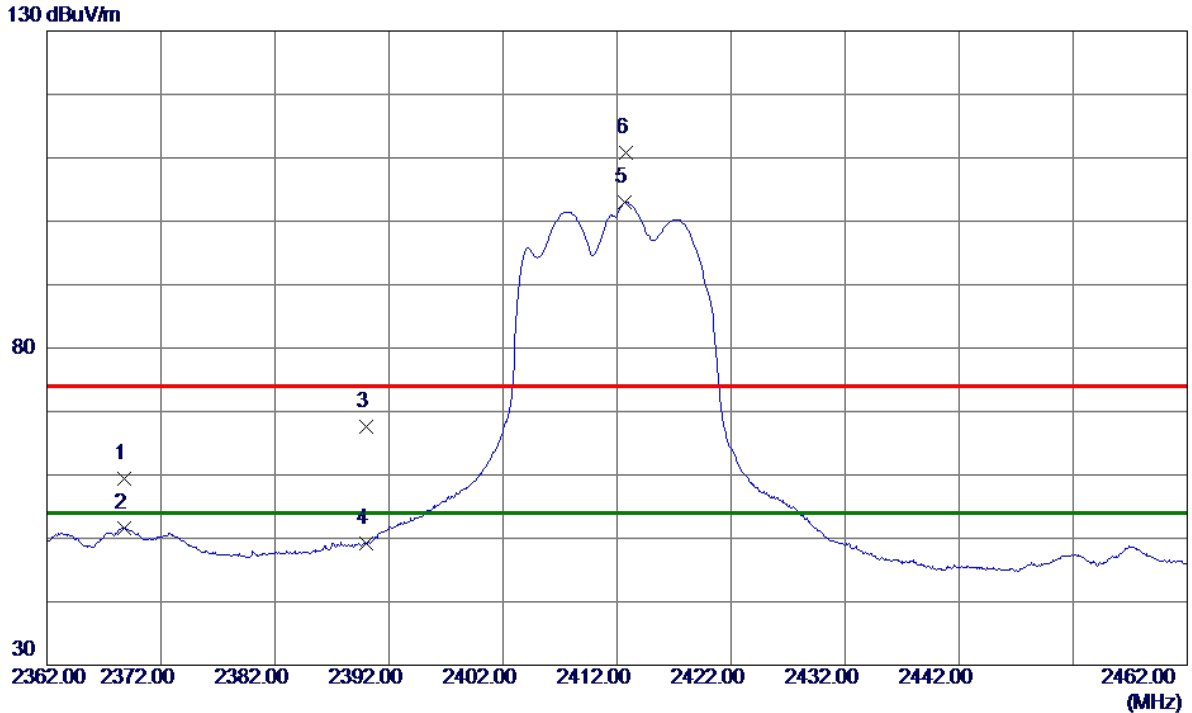

No.	Freq. MHz	Reading Level dBuV/m	Correct Factor dB	Measure ment dBuV/m	Limit dBuV/m	Margin dB	Detector	Comment
1	2368.7500	53.19	6.27	59.46	74.00	-14.54	Peak	
2	2368.7500	45.41	6.27	51.68	54.00	-2.32	AVG	
3	2390.0000	61.44	6.24	67.68	74.00	-6.32	Peak	
4	2390.0000	43.03	6.24	49.27	54.00	-4.73	AVG	
5 *	2412.7000	96.83	6.20	103.03	54.00	49.03	AVG	No Limit
6	2412.7500	104.63	6.20	110.83	74.00	36.83	Peak	No Limit

REMARKS:
 (1) Measurement Value = Reading Level + Correct Factor.
 (2) Margin Level = Measurement Value - Limit Value.

Test Mode: TX G Mode 2412 MHz

Horizontal

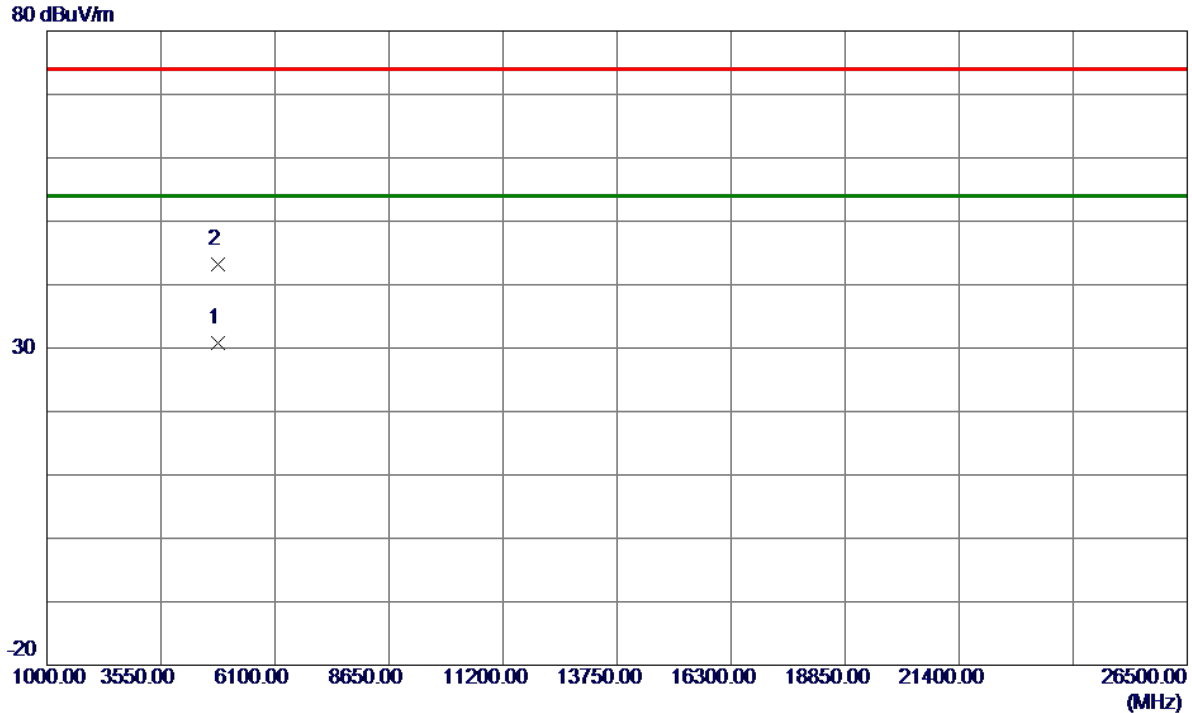

No.	Freq. MHz	Reading Level dBuV/m	Correct Factor dB	Measure ment dBuV/m	Limit dBuV/m	Margin dB	Detector	Comment
1 *	4824.2950	28.26	2.50	30.76	54.00	-23.24	AVG	
2	4824.7350	40.69	2.50	43.19	74.00	-30.81	Peak	

REMARKS:
 (1) Measurement Value = Reading Level + Correct Factor.
 (2) Margin Level = Measurement Value - Limit Value.

Test Mode: TX G Mode 2437 MHz

Vertical

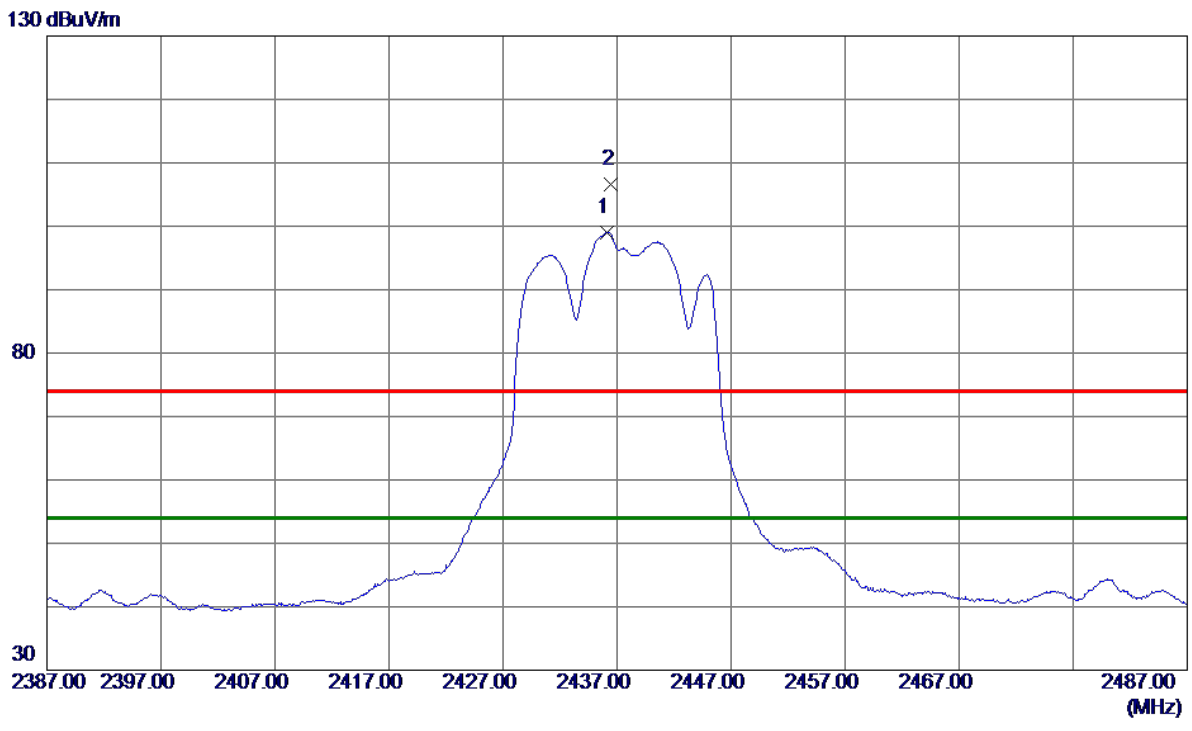

No.	Freq. MHz	Reading Level dBuV/m	Correct Factor dB	Measure ment dBuV/m	Limit dBuV/m	Margin dB	Detector	Comment
1 *	2436.1000	92.86	6.16	99.02	54.00	45.02	AVG	No Limit
2	2436.5000	100.38	6.16	106.54	74.00	32.54	Peak	No Limit

REMARKS:

- (1) Measurement Value = Reading Level + Correct Factor.
- (2) Margin Level = Measurement Value - Limit Value.

Test Mode: TX G Mode 2437 MHz

Vertical

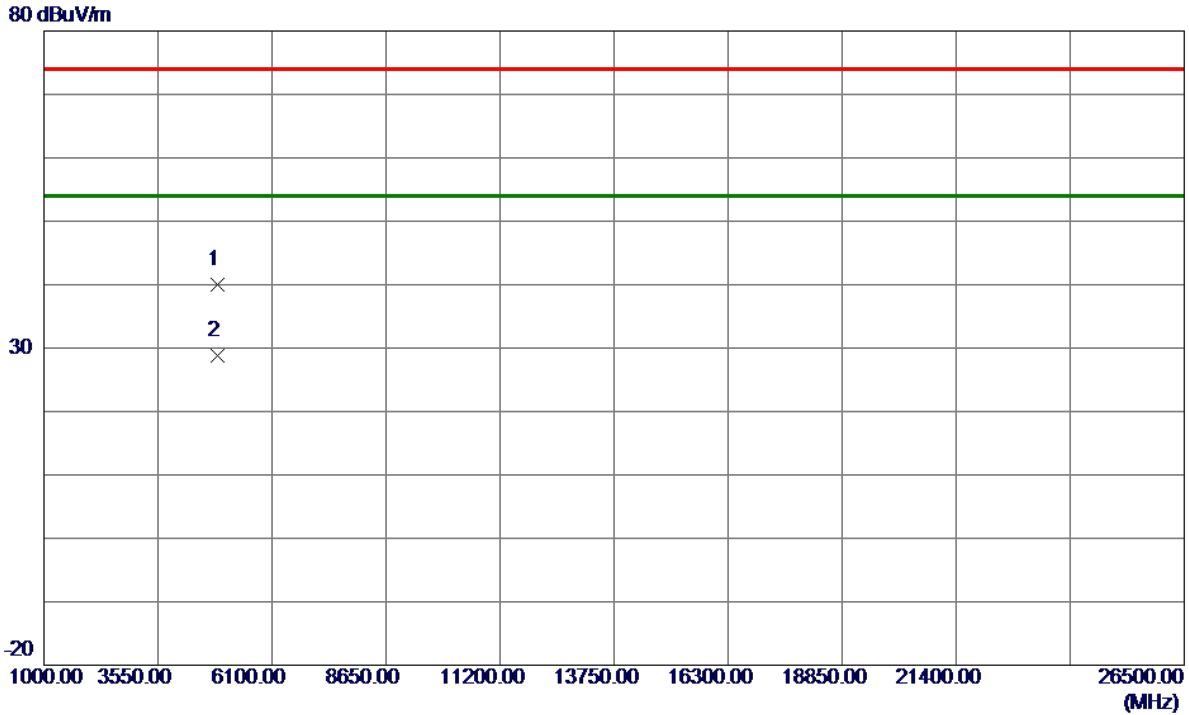

No.	Freq. MHz	Reading Level dBuV/m	Correct Factor dB	Measure ment dBuV/m	Limit dBuV/m	Margin dB	Detector	Comment
1	4870.4250	37.36	2.64	40.00	74.00	-34.00	Peak	
2 *	4873.9200	26.09	2.66	28.75	54.00	-25.25	AVG	

REMARKS:

(1) Measurement Value = Reading Level + Correct Factor.

(2) Margin Level = Measurement Value - Limit Value.

Test Mode: TX G Mode 2437 MHz

Horizontal

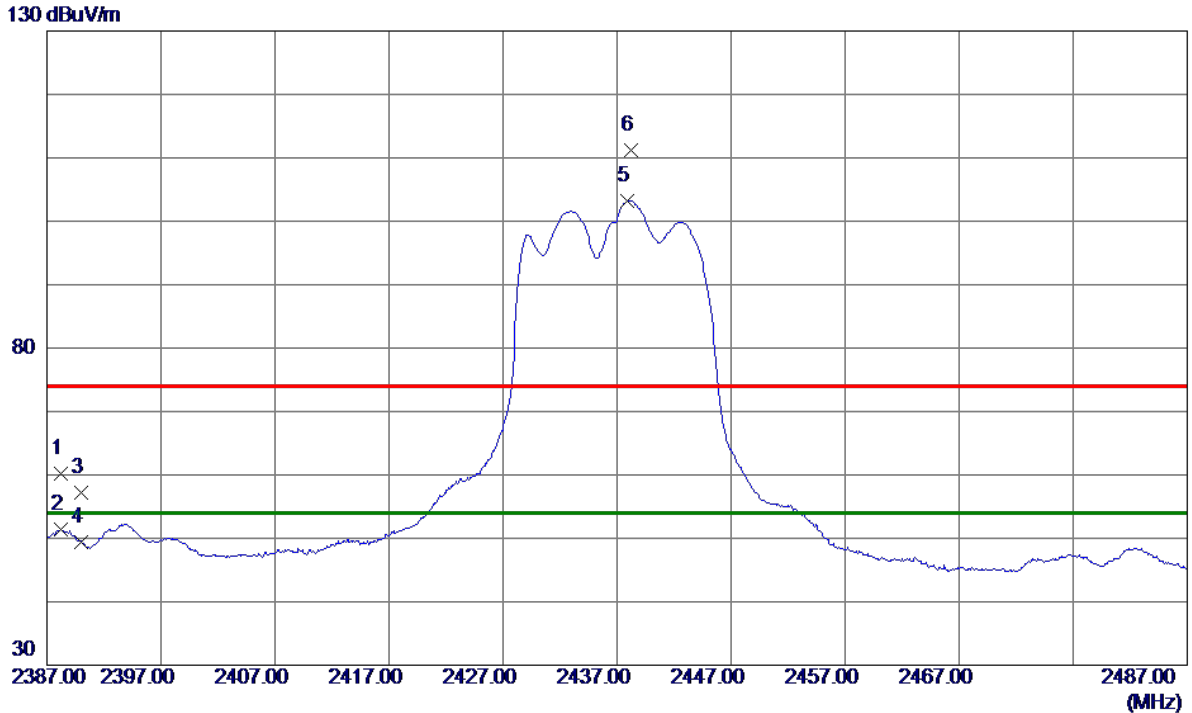

No.	Freq. MHz	Reading Level dBuV/m	Correct Factor dB	Measure ment dBuV/m	Limit dBuV/m	Margin dB	Detector	Comment
1	2388.2500	54.00	6.24	60.24	74.00	-13.76	Peak	
2	2388.2500	45.20	6.24	51.44	54.00	-2.56	AVG	
3	2390.0000	50.94	6.24	57.18	74.00	-16.82	Peak	
4	2390.0000	43.12	6.24	49.36	54.00	-4.64	AVG	
5 *	2437.9000	97.08	6.16	103.24	54.00	49.24	AVG	No Limit
6	2438.2000	104.95	6.16	111.11	74.00	37.11	Peak	No Limit

REMARKS:
 (1) Measurement Value = Reading Level + Correct Factor.
 (2) Margin Level = Measurement Value - Limit Value.

Test Mode: TX G Mode 2437 MHz

Horizontal

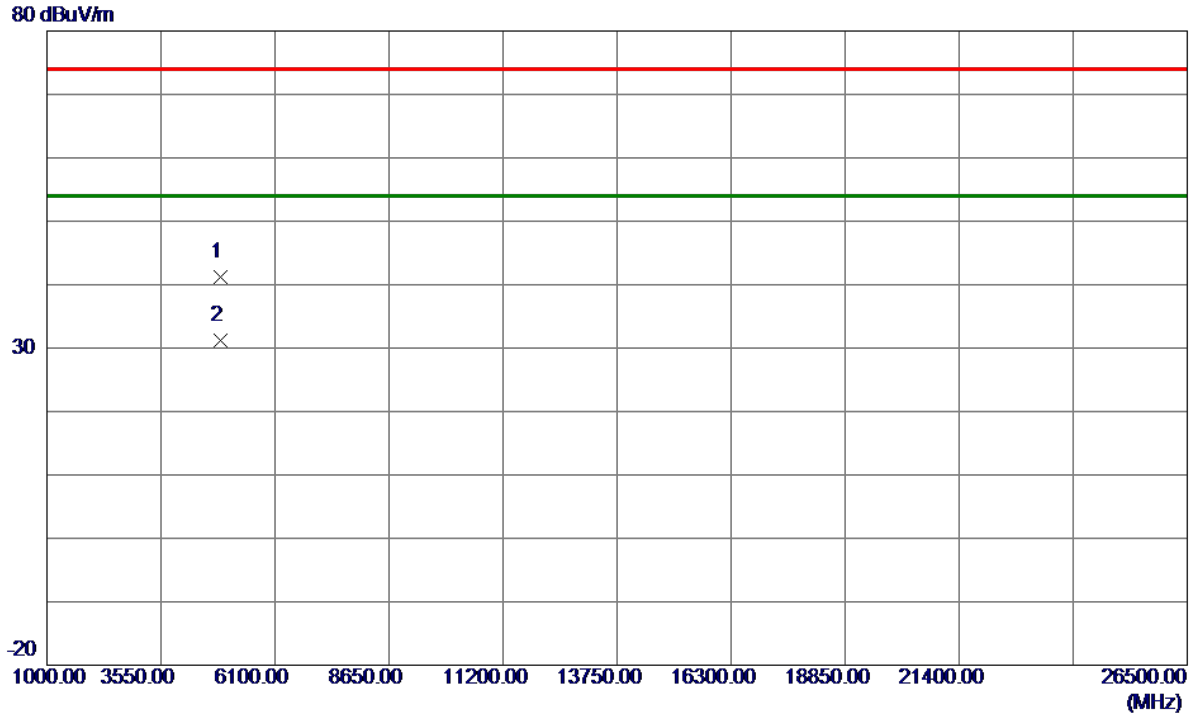

No.	Freq. MHz	Reading Level dBuV/m	Correct Factor dB	Measure ment dBuV/m	Limit dBuV/m	Margin dB	Detector	Comment
1	4875.0700	38.56	2.66	41.22	74.00	-32.78	Peak	
2 *	4875.5150	28.55	2.66	31.21	54.00	-22.79	AVG	

REMARKS:
 (1) Measurement Value = Reading Level + Correct Factor.
 (2) Margin Level = Measurement Value - Limit Value.

Test Mode: TX G Mode 2462 MHz

Vertical

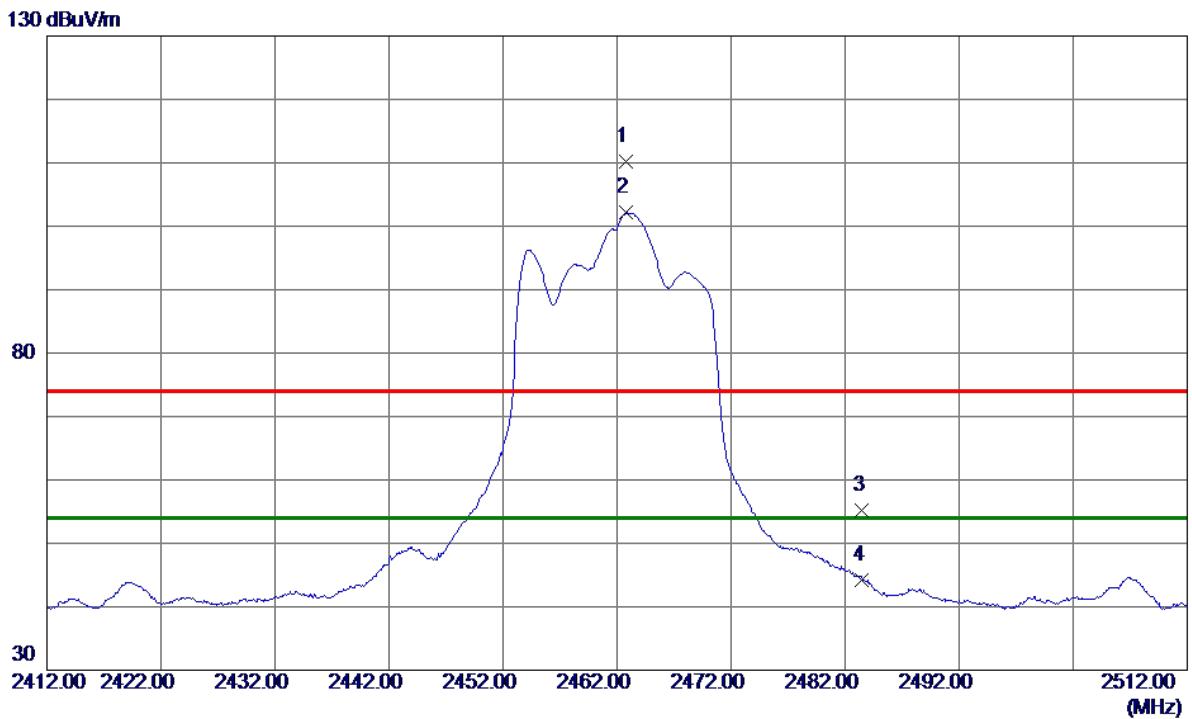

No.	Freq. MHz	Reading Level dBuV/m	Correct Factor dB	Measure ment dBuV/m	Limit dBuV/m	Margin dB	Detector	Comment
1	2462.8000	104.03	6.12	110.15	74.00	36.15	Peak	No Limit
2 *	2462.8000	95.99	6.12	102.11	54.00	48.11	AVG	No Limit
3	2483.5000	49.18	6.08	55.26	74.00	-18.74	Peak	
4	2483.5000	38.15	6.08	44.23	54.00	-9.77	AVG	

REMARKS:
 (1) Measurement Value = Reading Level + Correct Factor.
 (2) Margin Level = Measurement Value - Limit Value.

Test Mode: TX G Mode 2462 MHz

Vertical

80 dBuV/m

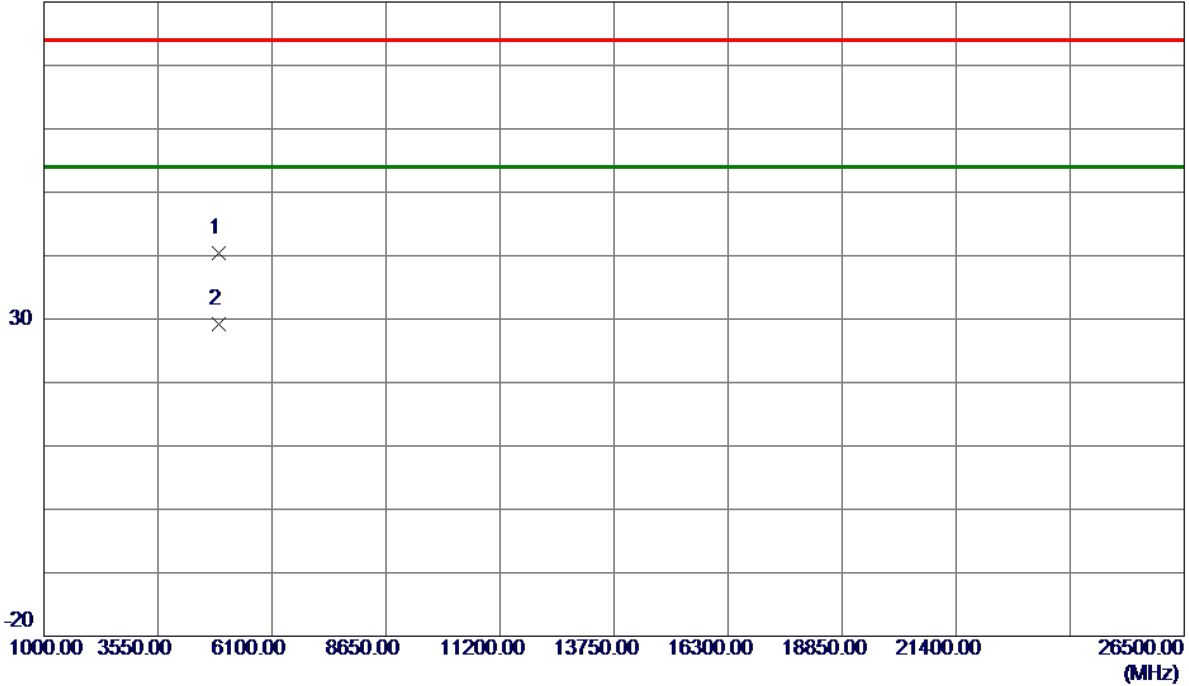

No.	Freq. MHz	Reading Level dBuV/m	Correct Factor dB	Measure ment dBuV/m	Limit dBuV/m	Margin dB	Detector	Comment
1	4920.2650	37.59	2.80	40.39	74.00	-33.61	Peak	
2 *	4922.4600	26.47	2.81	29.28	54.00	-24.72	AVG	

REMARKS:

- (1) Measurement Value = Reading Level + Correct Factor.
- (2) Margin Level = Measurement Value - Limit Value.

Test Mode: TX G Mode 2462 MHz

Horizontal

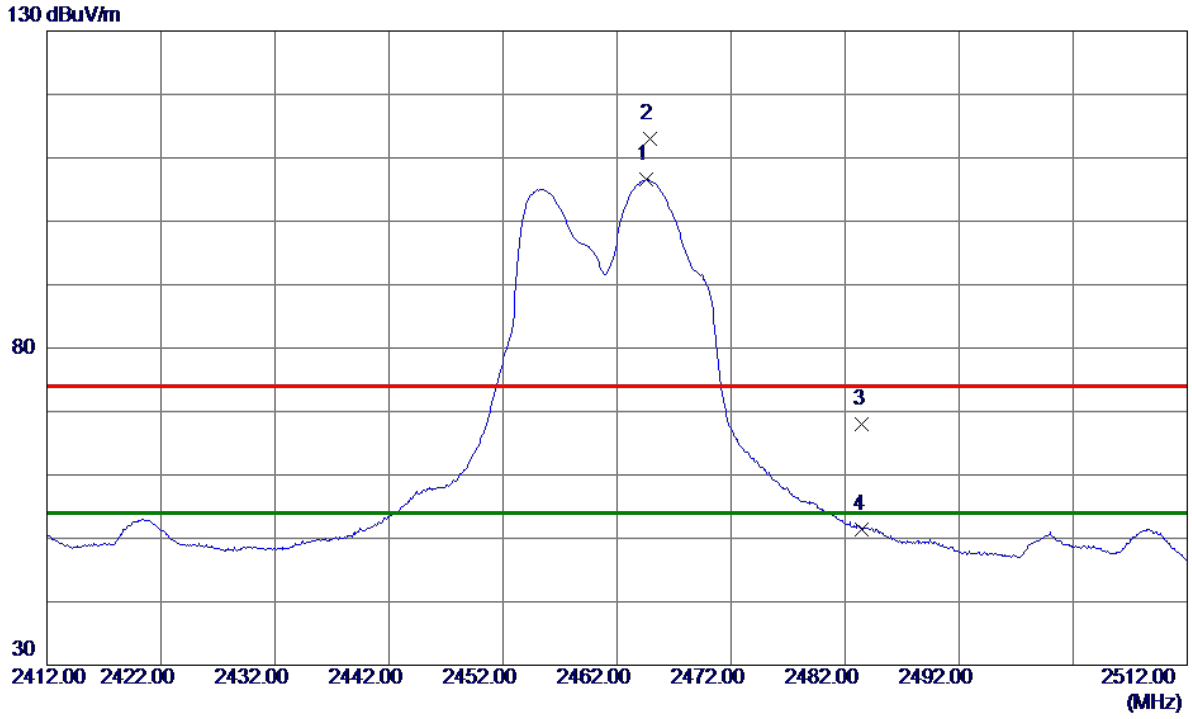

No.	Freq. MHz	Reading Level dBuV/m	Correct Factor dB	Measure ment dBuV/m	Limit dBuV/m	Margin dB	Detector	Comment
1 *	2464.5500	100.47	6.11	106.58	54.00	52.58	AVG	No Limit
2	2464.8500	106.97	6.11	113.08	74.00	39.08	Peak	No Limit
3	2483.5000	61.92	6.08	68.00	74.00	-6.00	Peak	
4	2483.5000	45.40	6.08	51.48	54.00	-2.52	AVG	

REMARKS:
 (1) Measurement Value = Reading Level + Correct Factor.
 (2) Margin Level = Measurement Value - Limit Value.

Test Mode: TX G Mode 2462 MHz

Horizontal

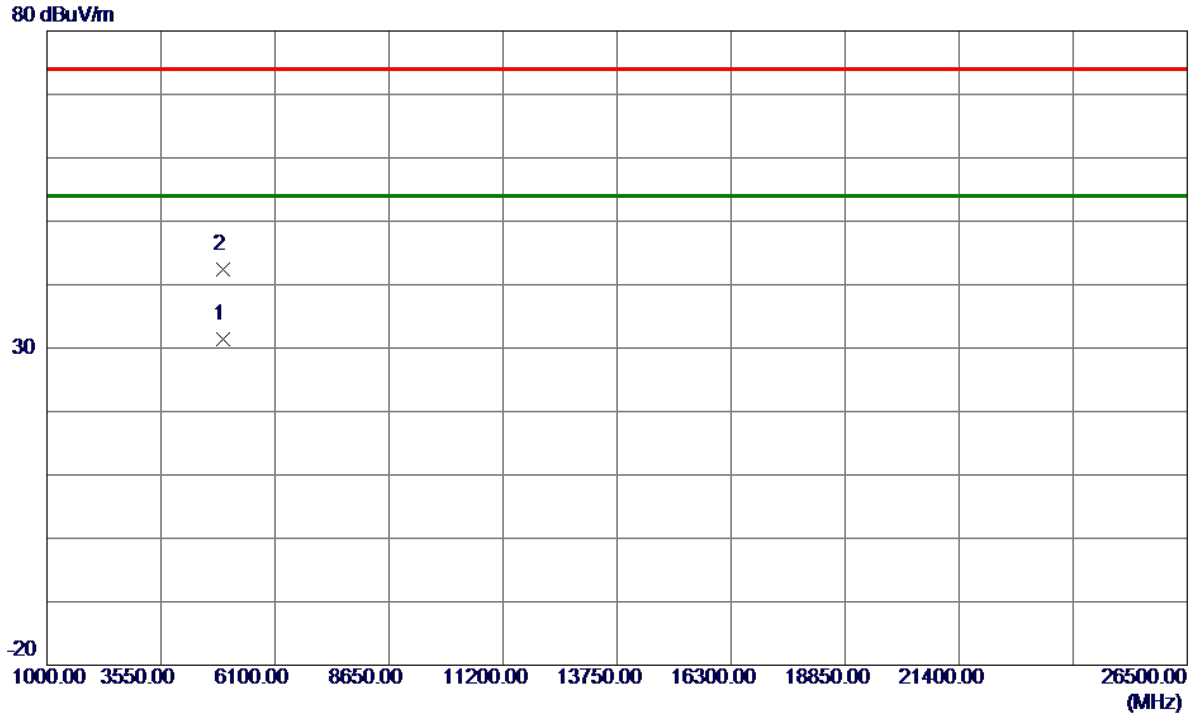

No.	Freq. MHz	Reading Level dBuV/m	Correct Factor dB	Measure ment dBuV/m	Limit dBuV/m	Margin dB	Detector	Comment
1 *	4924.6500	28.56	2.82	31.38	54.00	-22.62	AVG	
2	4925.0350	39.65	2.82	42.47	74.00	-31.53	Peak	

REMARKS:
 (1) Measurement Value = Reading Level + Correct Factor.
 (2) Margin Level = Measurement Value - Limit Value.

Test Mode: TX N-20M Mode 2412 MHz

Vertical

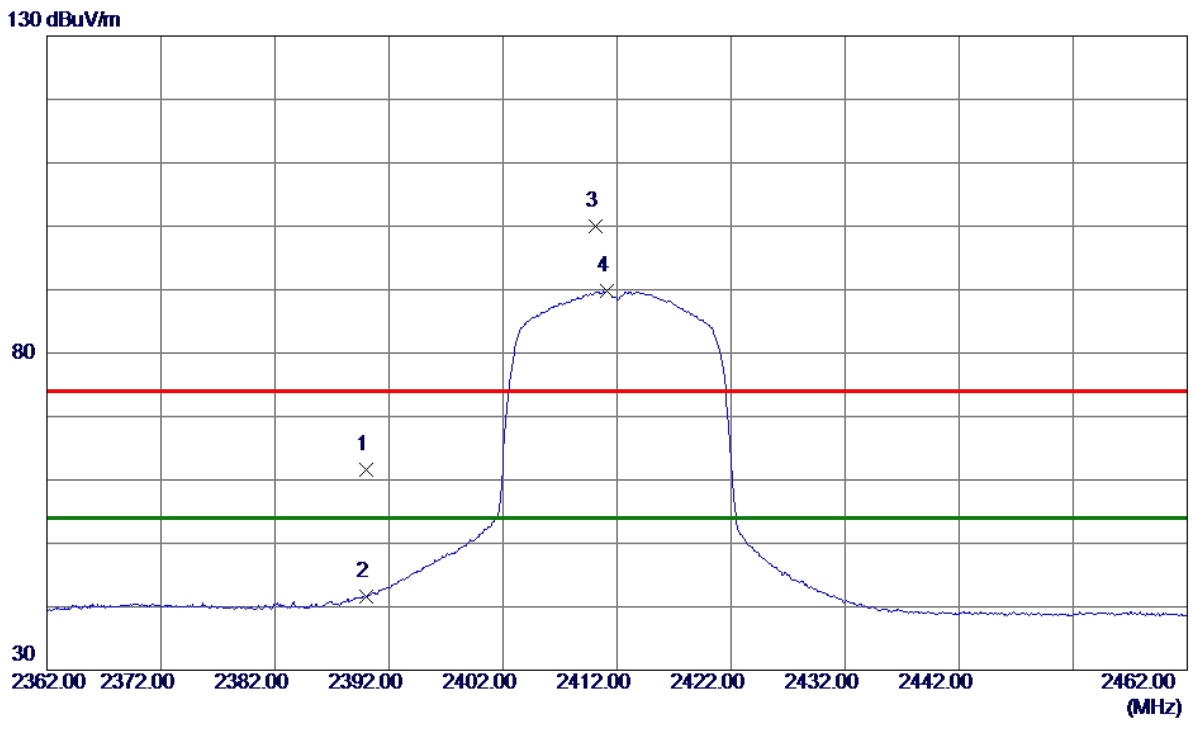

No.	Freq. MHz	Reading Level dBuV/m	Correct Factor dB	Measure ment dBuV/m	Limit dBuV/m	Margin dB	Detector	Comment
1	2390.0000	53.54	8.11	61.65	74.00	-12.35	Peak	
2	2390.0000	33.44	8.11	41.55	54.00	-12.45	AVG	
3	2410.1500	91.82	8.17	99.99	74.00	25.99	Peak	No Limit
4 *	2411.1500	81.69	8.17	89.86	54.00	35.86	AVG	No Limit

REMARKS:

- (1) Measurement Value = Reading Level + Correct Factor.
- (2) Margin Level = Measurement Value - Limit Value.

Test Mode: TX N-20M Mode 2412 MHz

Vertical

80 dBuV/m

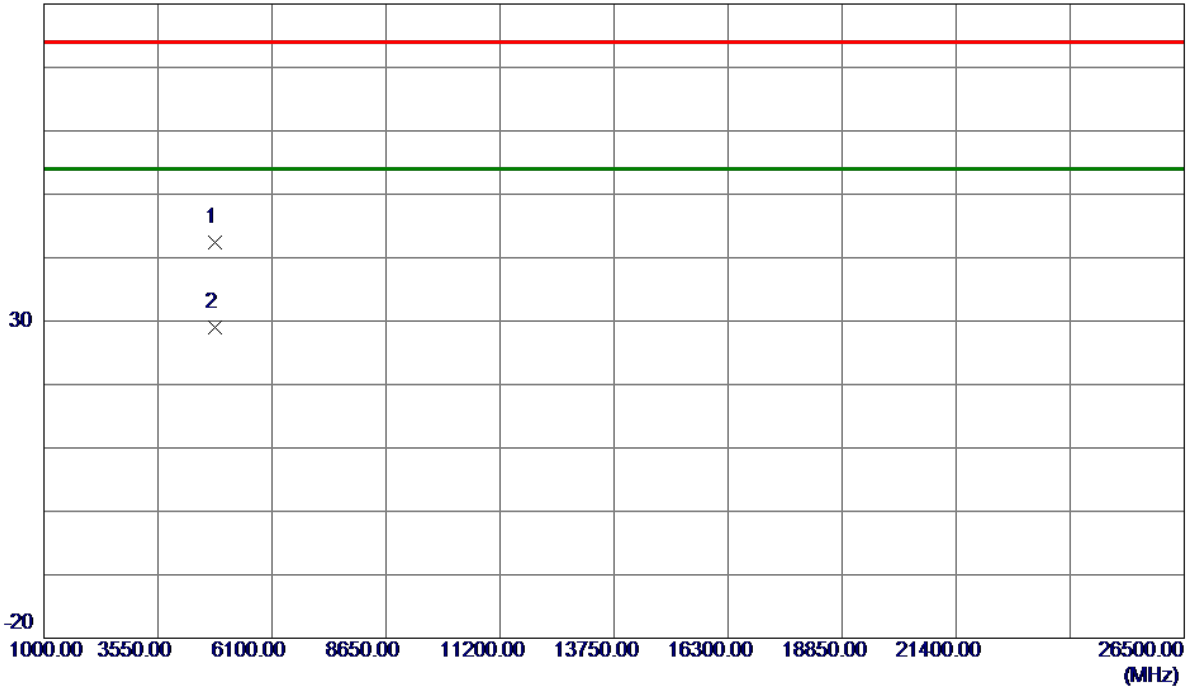

No.	Freq. MHz	Reading Level dBuV/m	Correct Factor dB	Measure ment dBuV/m	Limit dBuV/m	Margin dB	Detector	Comment
1	4822.1530	37.71	4.73	42.44	74.00	-31.56	Peak	
2 *	4825.8350	24.28	4.75	29.03	54.00	-24.97	AVG	

REMARKS:

- (1) Measurement Value = Reading Level + Correct Factor.
- (2) Margin Level = Measurement Value - Limit Value.

Test Mode: TX N-20M Mode 2412 MHz

Horizontal

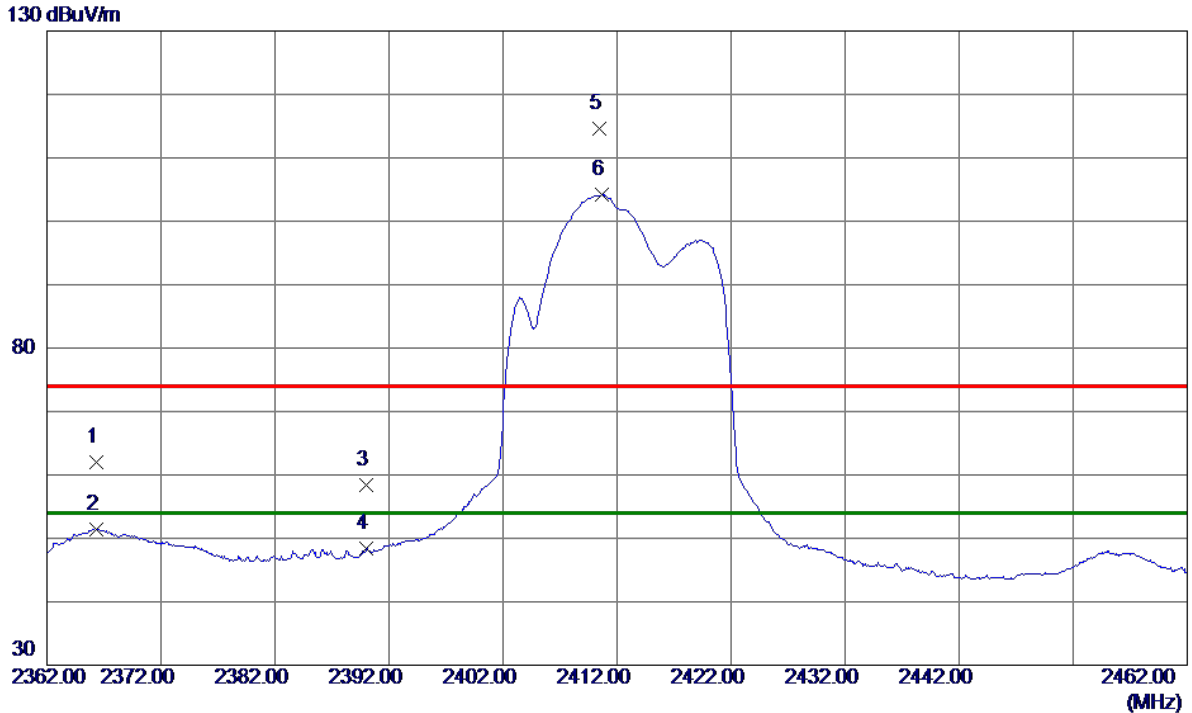

No.	Freq. MHz	Reading Level dBuV/m	Correct Factor dB	Measure ment dBuV/m	Limit dBuV/m	Margin dB	Detector	Comment
1	2366.3500	54.03	8.04	62.07	74.00	-11.93	Peak	
2	2366.3500	43.44	8.04	51.48	54.00	-2.52	AVG	
3	2390.0000	50.31	8.11	58.42	74.00	-15.58	Peak	
4	2390.0000	40.28	8.11	48.39	54.00	-5.61	AVG	
5	2410.4500	106.43	8.17	114.60	74.00	40.60	Peak	No Limit
6 *	2410.7000	96.01	8.17	104.18	54.00	50.18	AVG	No Limit

REMARKS:
 (1) Measurement Value = Reading Level + Correct Factor.
 (2) Margin Level = Measurement Value - Limit Value.

Test Mode: TX N-20M Mode 2412 MHz

Horizontal

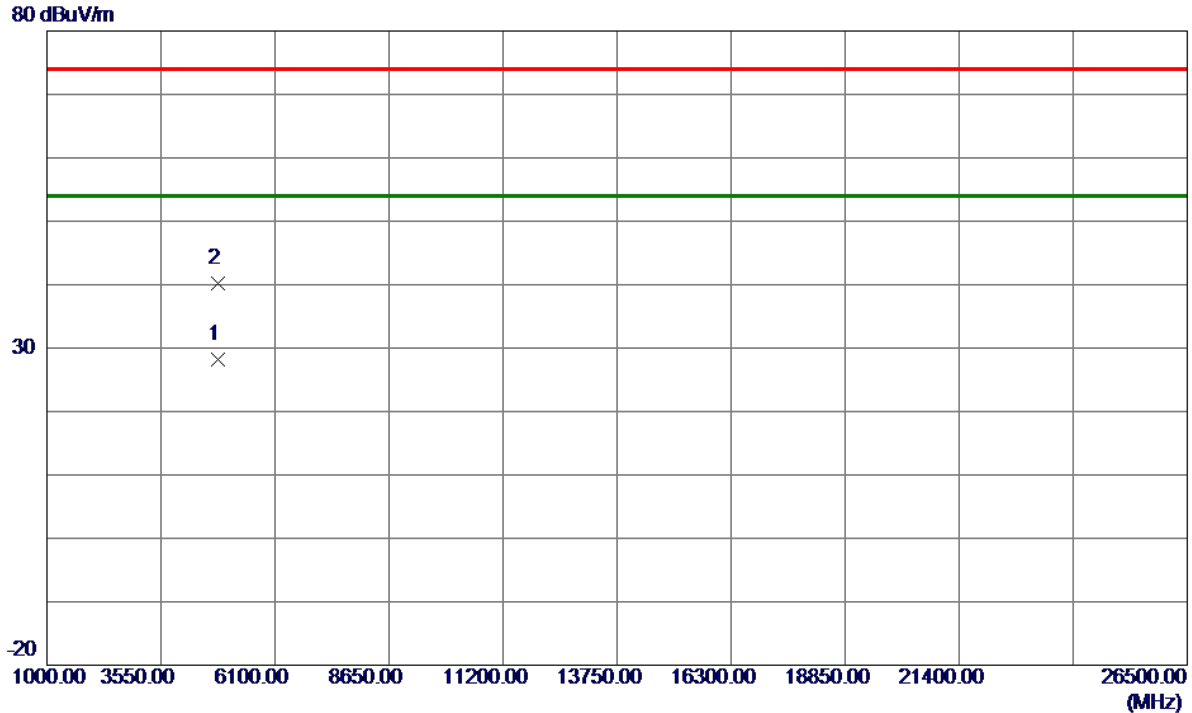

No.	Freq. MHz	Reading Level dBuV/m	Correct Factor dB	Measure ment dBuV/m	Limit dBuV/m	Margin dB	Detector	Comment
1 *	4814.0600	23.49	4.70	28.19	54.00	-25.81	AVG	
2	4822.7700	35.54	4.74	40.28	74.00	-33.72	Peak	

REMARKS:
 (1) Measurement Value = Reading Level + Correct Factor.
 (2) Margin Level = Measurement Value - Limit Value.

Test Mode: TX N-20M Mode 2437 MHz

Vertical

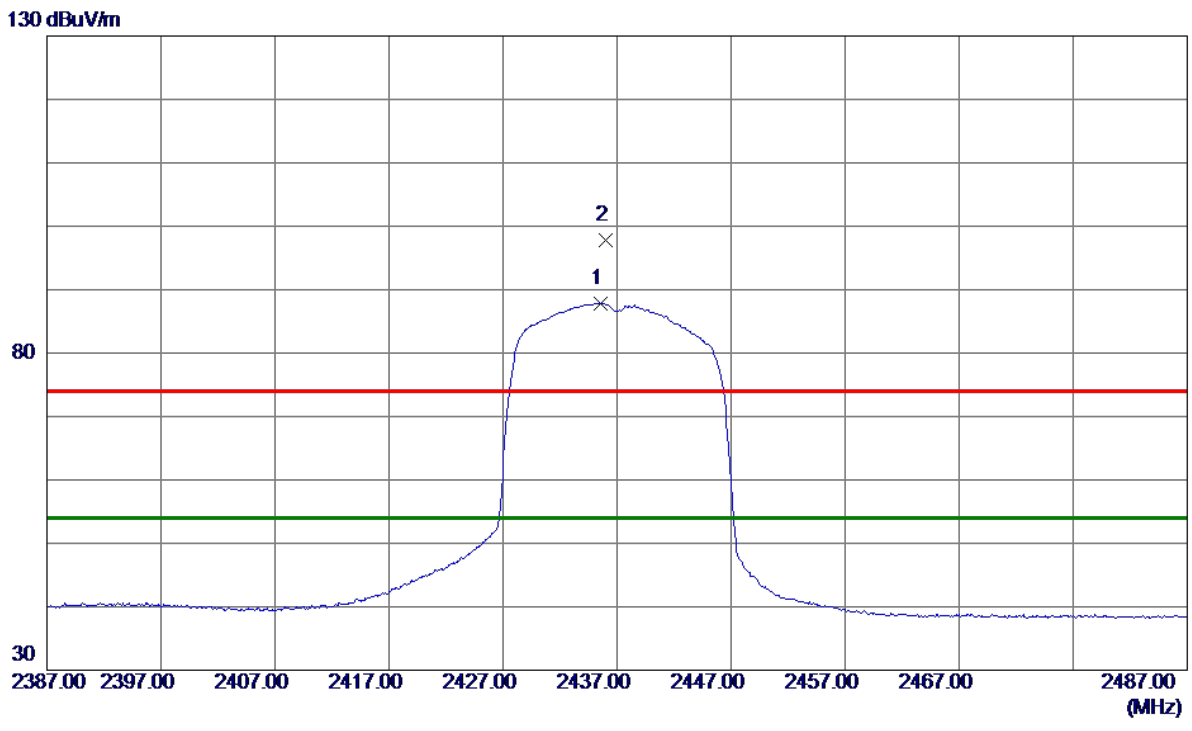

No.	Freq. MHz	Reading Level dBuV/m	Correct Factor dB	Measure ment dBuV/m	Limit dBuV/m	Margin dB	Detector	Comment
1 *	2435.6000	79.65	8.24	87.89	54.00	33.89	AVG	No Limit
2	2436.0500	89.58	8.24	97.82	74.00	23.82	Peak	No Limit

REMARKS:

- (1) Measurement Value = Reading Level + Correct Factor.
- (2) Margin Level = Measurement Value - Limit Value.

Test Mode: TX N-20M Mode 2437 MHz

Vertical

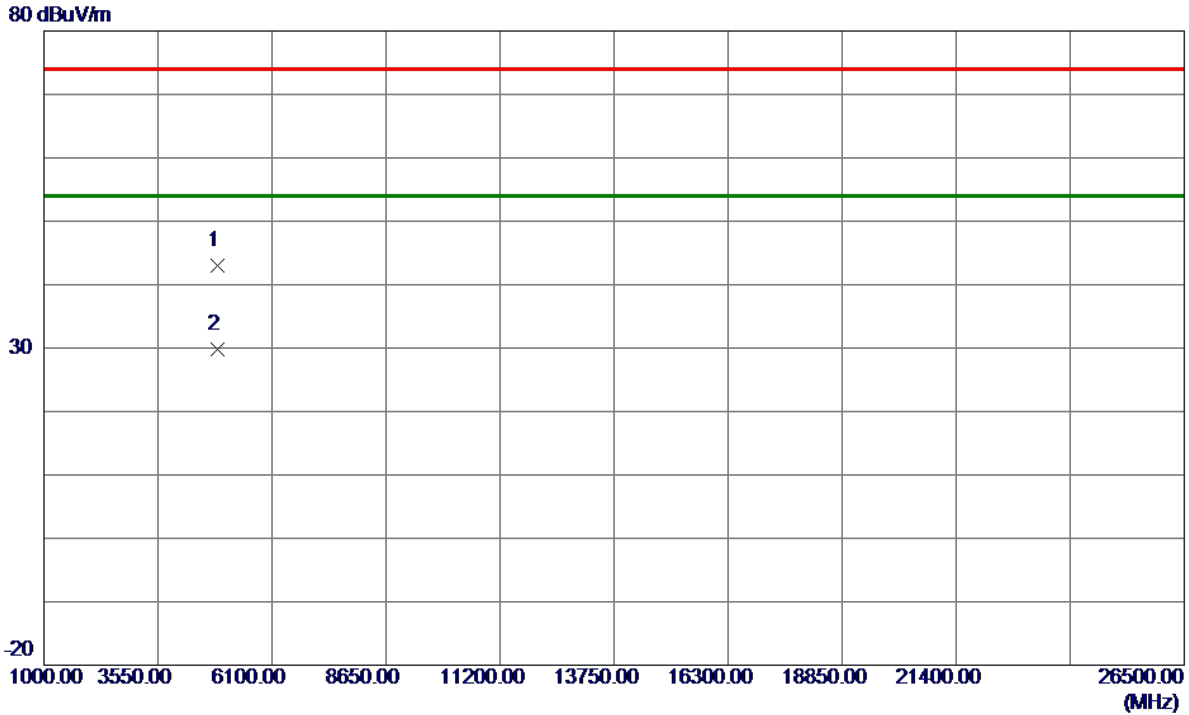

No.	Freq. MHz	Reading Level dBuV/m	Correct Factor dB	Measure ment dBuV/m	Limit dBuV/m	Margin dB	Detector	Comment
1	4872.2780	37.97	4.98	42.95	74.00	-31.05	Peak	
2 *	4872.4770	24.90	4.98	29.88	54.00	-24.12	AVG	

REMARKS:

(1) Measurement Value = Reading Level + Correct Factor.

(2) Margin Level = Measurement Value - Limit Value.

Test Mode: TX N-20M Mode 2437 MHz

Horizontal

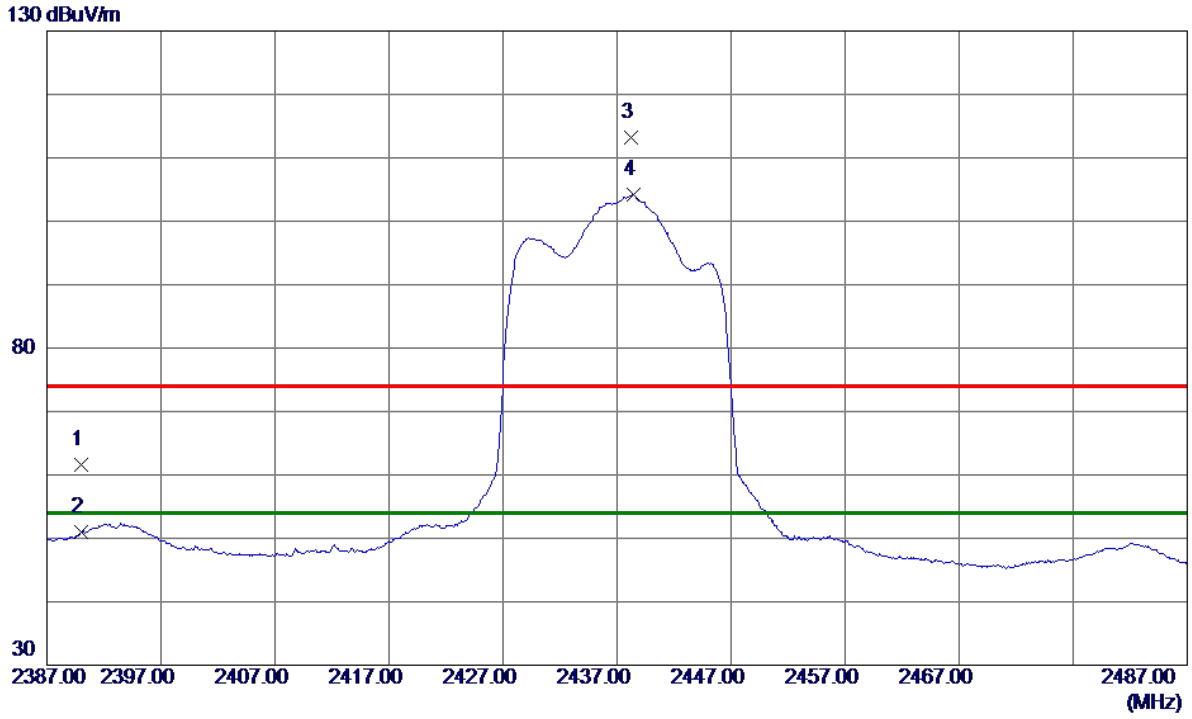

No.	Freq. MHz	Reading Level dBuV/m	Correct Factor dB	Measure ment dBuV/m	Limit dBuV/m	Margin dB	Detector	Comment
1	2390.0000	53.52	8.11	61.63	74.00	-12.37	Peak	
2	2390.0000	42.83	8.11	50.94	54.00	-3.06	AVG	
3	2438.2500	105.03	8.25	113.28	74.00	39.28	Peak	No Limit
4 *	2438.4000	95.91	8.25	104.16	54.00	50.16	AVG	No Limit

REMARKS:
 (1) Measurement Value = Reading Level + Correct Factor.
 (2) Margin Level = Measurement Value - Limit Value.

Test Mode: TX N-20M Mode 2437 MHz

Horizontal

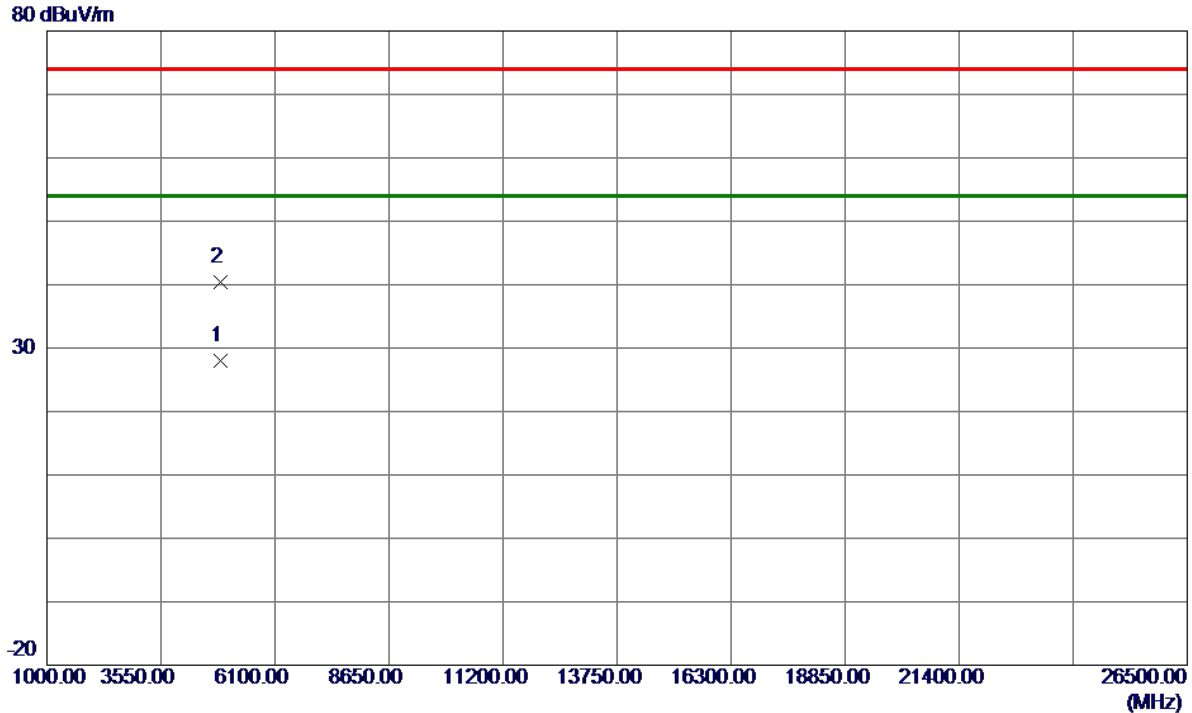

No.	Freq. MHz	Reading Level dBuV/m	Correct Factor dB	Measure ment dBuV/m	Limit dBuV/m	Margin dB	Detector	Comment
1 *	4868.1500	23.11	4.96	28.07	54.00	-25.93	AVG	
2	4876.4600	35.37	5.00	40.37	74.00	-33.63	Peak	

REMARKS:
 (1) Measurement Value = Reading Level + Correct Factor.
 (2) Margin Level = Measurement Value - Limit Value.

Test Mode: TX N-20M Mode 2462 MHz

Vertical

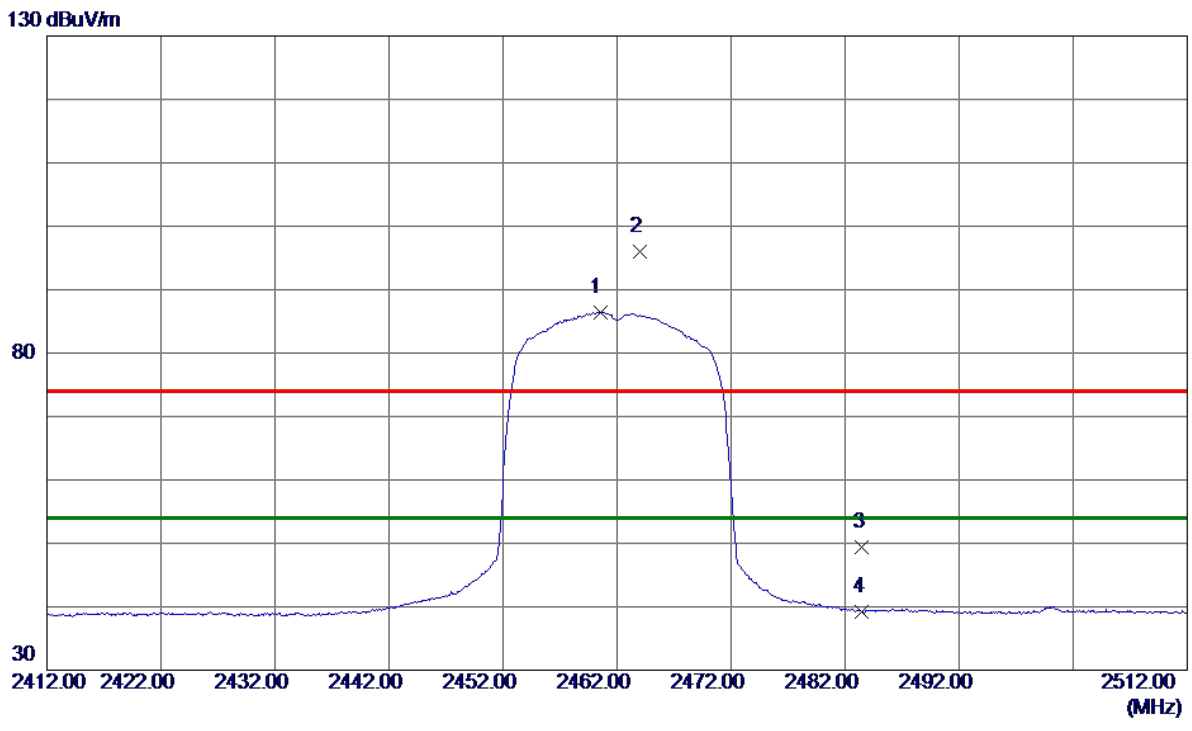

No.	Freq. MHz	Reading Level dBuV/m	Correct Factor dB	Measure ment dBuV/m	Limit dBuV/m	Margin dB	Detector	Comment
1 *	2460.5000	78.14	8.31	86.45	54.00	32.45	AVG	No Limit
2	2464.0000	87.67	8.32	95.99	74.00	21.99	Peak	No Limit
3	2483.5000	41.10	8.38	49.48	74.00	-24.52	Peak	
4	2483.5000	30.74	8.38	39.12	54.00	-14.88	AVG	

REMARKS:

- (1) Measurement Value = Reading Level + Correct Factor.
- (2) Margin Level = Measurement Value - Limit Value.

Test Mode: TX N-20M Mode 2462 MHz

Vertical

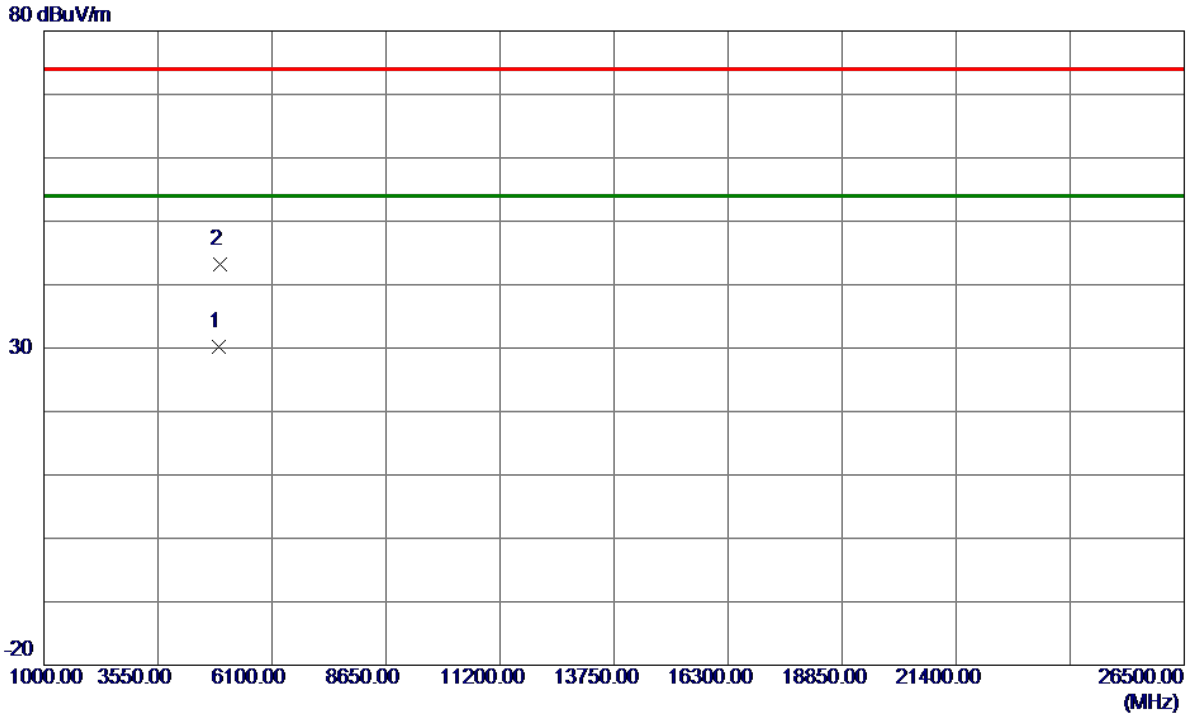

No.	Freq. MHz	Reading Level dBuV/m	Correct Factor dB	Measure ment dBuV/m	Limit dBuV/m	Margin dB	Detector	Comment
1 *	4922.3800	24.94	5.23	30.17	54.00	-23.83	AVG	
2	4926.3230	37.93	5.25	43.18	74.00	-30.82	Peak	

REMARKS:

(1) Measurement Value = Reading Level + Correct Factor.

(2) Margin Level = Measurement Value - Limit Value.

Test Mode: TX N-20M Mode 2462 MHz

Horizontal

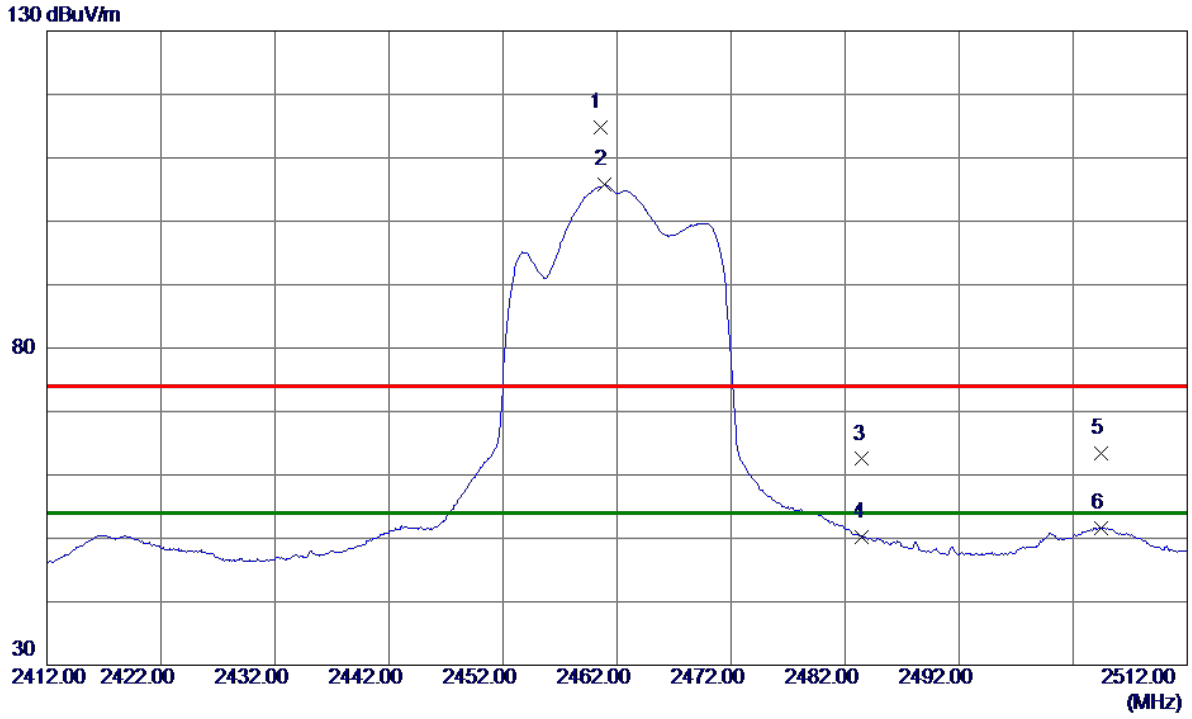

No.	Freq. MHz	Reading Level dBuV/m	Correct Factor dB	Measure ment dBuV/m	Limit dBuV/m	Margin dB	Detector	Comment
1	2460.5000	106.55	8.31	114.86	74.00	40.86	Peak	No Limit
2 *	2460.8500	97.43	8.32	105.75	54.00	51.75	AVG	No Limit
3	2483.5000	54.12	8.38	62.50	74.00	-11.50	Peak	
4	2483.5000	41.83	8.38	50.21	54.00	-3.79	AVG	
5	2504.4500	55.02	8.44	63.46	74.00	-10.54	Peak	
6	2504.4500	43.20	8.44	51.64	54.00	-2.36	AVG	

REMARKS:
 (1) Measurement Value = Reading Level + Correct Factor.
 (2) Margin Level = Measurement Value - Limit Value.

Test Mode: TX N-20M Mode 2462 MHz

Horizontal

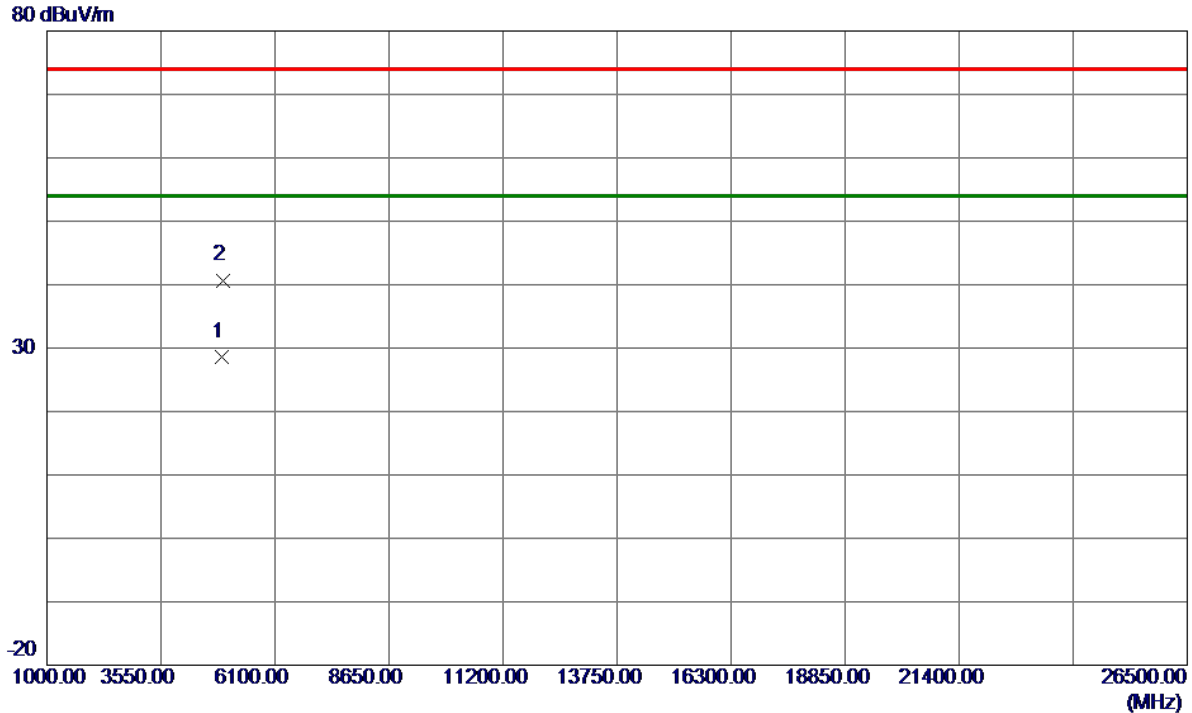

No.	Freq. MHz	Reading Level dBuV/m	Correct Factor dB	Measure ment dBuV/m	Limit dBuV/m	Margin dB	Detector	Comment
1 *	4918.0299	23.30	5.21	28.51	54.00	-25.49	AVG	
2	4924.2799	35.46	5.24	40.70	74.00	-33.30	Peak	

REMARKS:
 (1) Measurement Value = Reading Level + Correct Factor.
 (2) Margin Level = Measurement Value - Limit Value.

Test Mode: TX N-40M Mode 2422MHz

Vertical

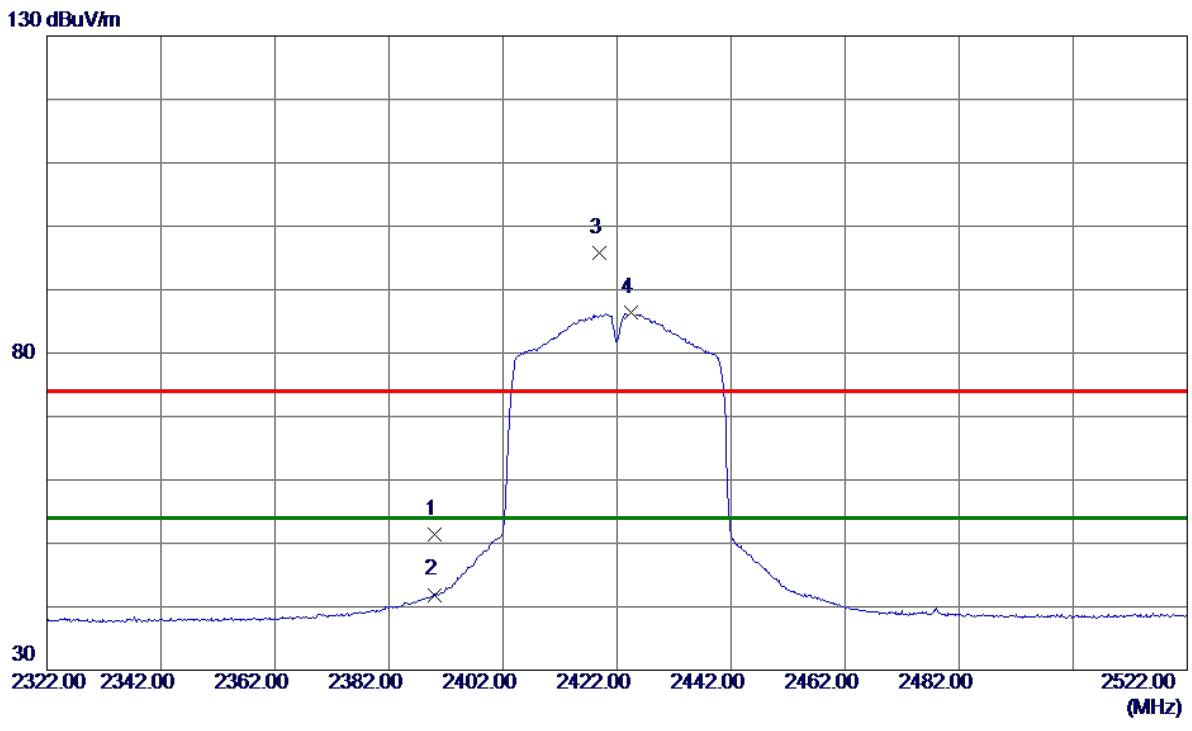

No.	Freq. MHz	Reading Level dBuV/m	Correct Factor dB	Measurement dBuV/m	Limit dBuV/m	Margin dB	Detector	Comment
1	2390.0000	43.23	8.11	51.34	74.00	-22.66	Peak	
2	2390.0000	33.79	8.11	41.90	54.00	-12.10	AVG	
3	2418.8000	87.67	8.19	95.86	74.00	21.86	Peak	No Limit
4 *	2424.5000	78.16	8.21	86.37	54.00	32.37	AVG	No Limit

REMARKS:

- (1) Measurement Value = Reading Level + Correct Factor.
- (2) Margin Level = Measurement Value - Limit Value.

Test Mode: TX N-40M Mode 2422MHz

Vertical



No.	Freq. MHz	Reading Level dBuV/m	Correct Factor dB	Measure ment dBuV/m	Limit dBuV/m	Margin dB	Detector	Comment
1	4842.4880	38.30	4.83	43.13	74.00	-30.87	Peak	
2 *	4843.9220	25.21	4.84	30.05	54.00	-23.95	AVG	

REMARKS:

- (1) Measurement Value = Reading Level + Correct Factor.
- (2) Margin Level = Measurement Value - Limit Value.

Test Mode: TX N-40M Mode 2422MHz

Horizontal

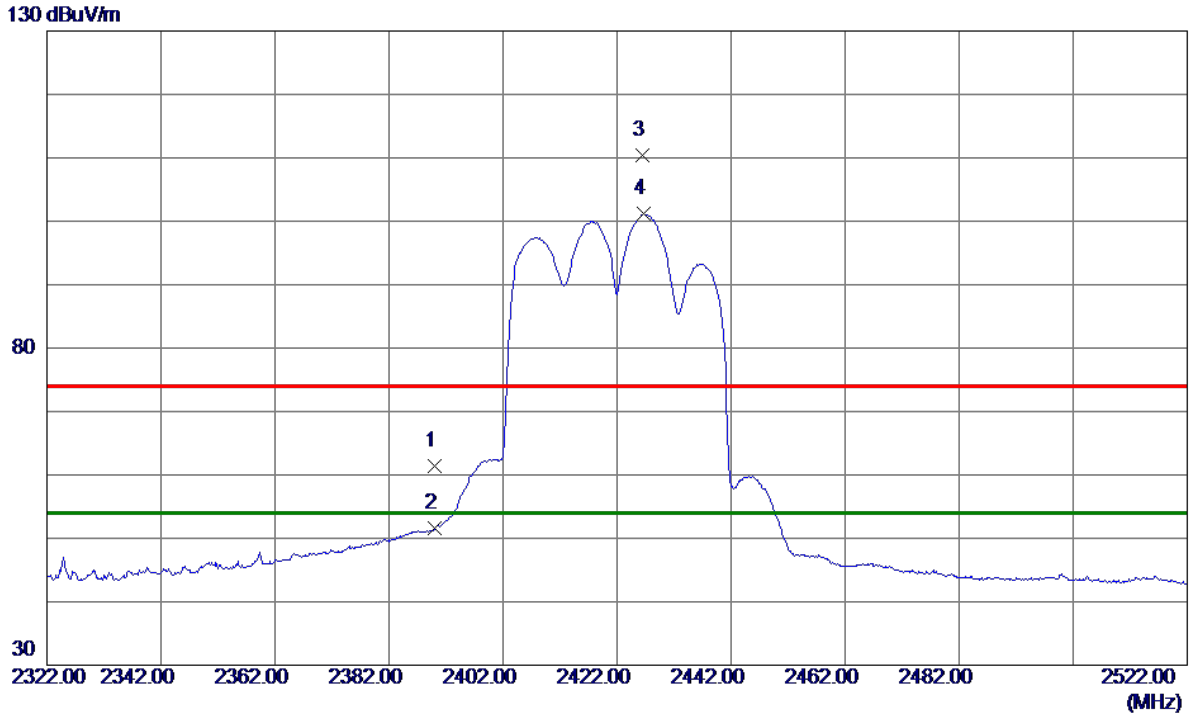

No.	Freq. MHz	Reading Level dBuV/m	Correct Factor dB	Measure ment dBuV/m	Limit dBuV/m	Margin dB	Detector	Comment
1	2390.0000	53.33	8.11	61.44	74.00	-12.56	Peak	
2	2390.0000	43.42	8.11	51.53	54.00	-2.47	AVG	
3	2426.5000	102.13	8.22	110.35	74.00	36.35	Peak	No Limit
4 *	2426.6000	93.01	8.22	101.23	54.00	47.23	AVG	No Limit

REMARKS:
 (1) Measurement Value = Reading Level + Correct Factor.
 (2) Margin Level = Measurement Value - Limit Value.

Test Mode: TX N-40M Mode 2422MHz

Horizontal

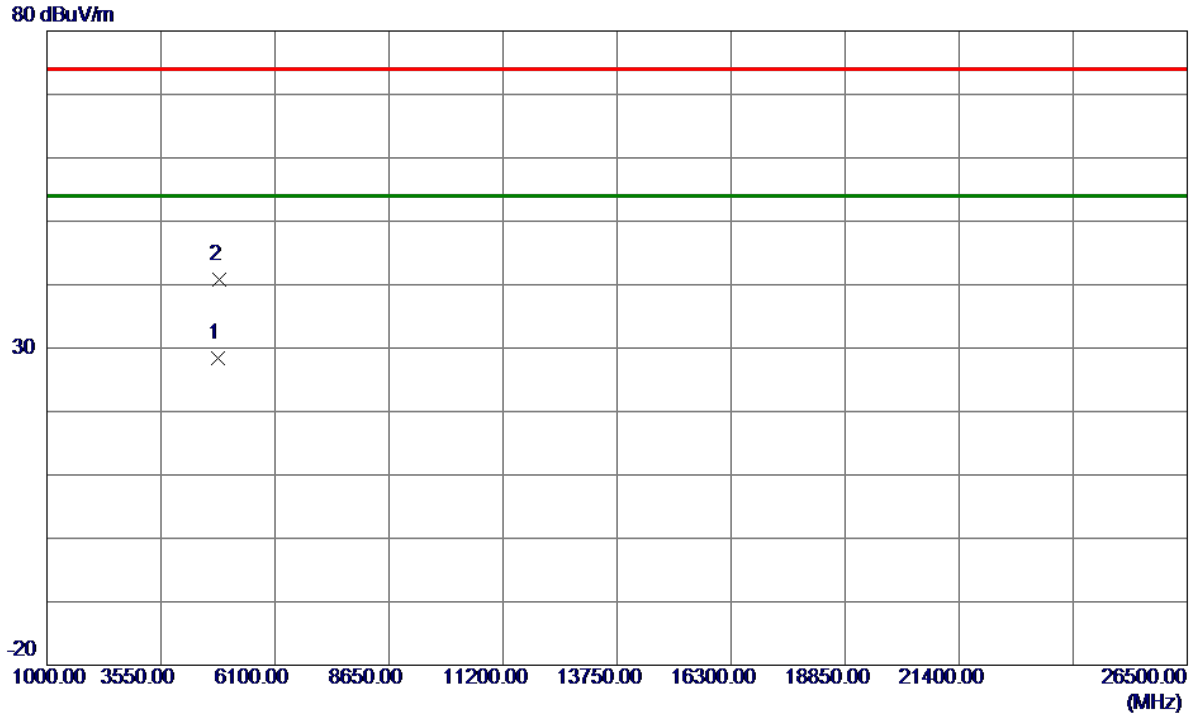

No.	Freq. MHz	Reading Level dBuV/m	Correct Factor dB	Measure ment dBuV/m	Limit dBuV/m	Margin dB	Detector	Comment
1 *	4834.3600	23.67	4.79	28.46	54.00	-25.54	AVG	
2	4840.8300	35.99	4.83	40.82	74.00	-33.18	Peak	

REMARKS:
 (1) Measurement Value = Reading Level + Correct Factor.
 (2) Margin Level = Measurement Value - Limit Value.

Test Mode: TX N-40M Mode 2437 MHz

Vertical

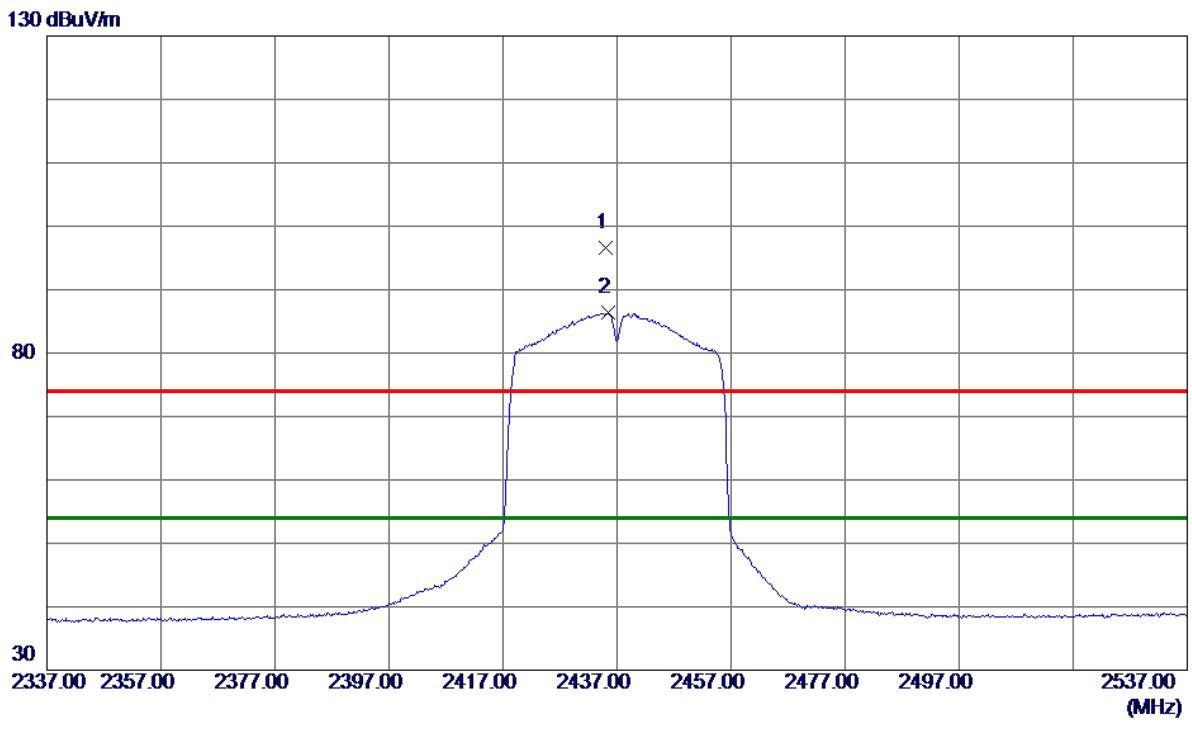

No.	Freq. MHz	Reading Level dBuV/m	Correct Factor dB	Measure ment dBuV/m	Limit dBuV/m	Margin dB	Detector	Comment
1	2435.1000	88.38	8.24	96.62	74.00	22.62	Peak	No Limit
2 *	2435.4000	78.10	8.24	86.34	54.00	32.34	AVG	No Limit

REMARKS:

- (1) Measurement Value = Reading Level + Correct Factor.
- (2) Margin Level = Measurement Value - Limit Value.

Test Mode: TX N-40M Mode 2437 MHz

Vertical

80 dBuV/m

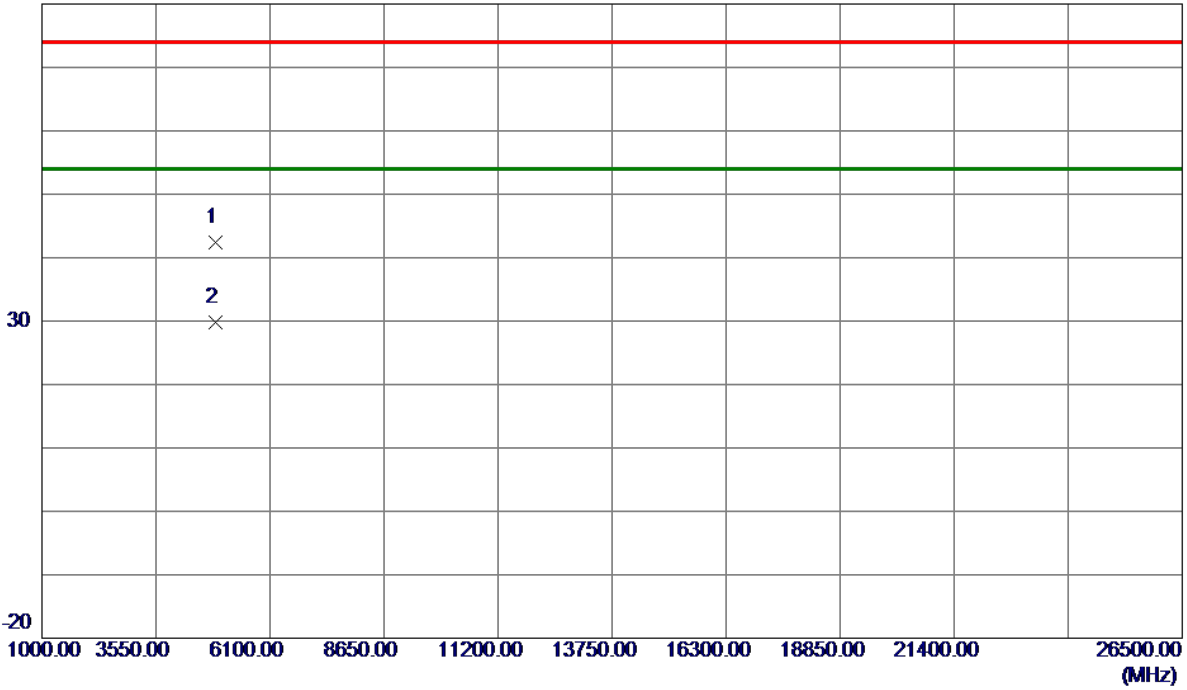

No.	Freq. MHz	Reading Level dBuV/m	Correct Factor dB	Measure ment dBuV/m	Limit dBuV/m	Margin dB	Detector	Comment
1	4872.7200	37.33	4.98	42.31	74.00	-31.69	Peak	
2 *	4872.8950	24.84	4.98	29.82	54.00	-24.18	AVG	

REMARKS:

(1) Measurement Value = Reading Level + Correct Factor.

(2) Margin Level = Measurement Value - Limit Value.

Test Mode: TX N-40M Mode 2437 MHz

Horizontal

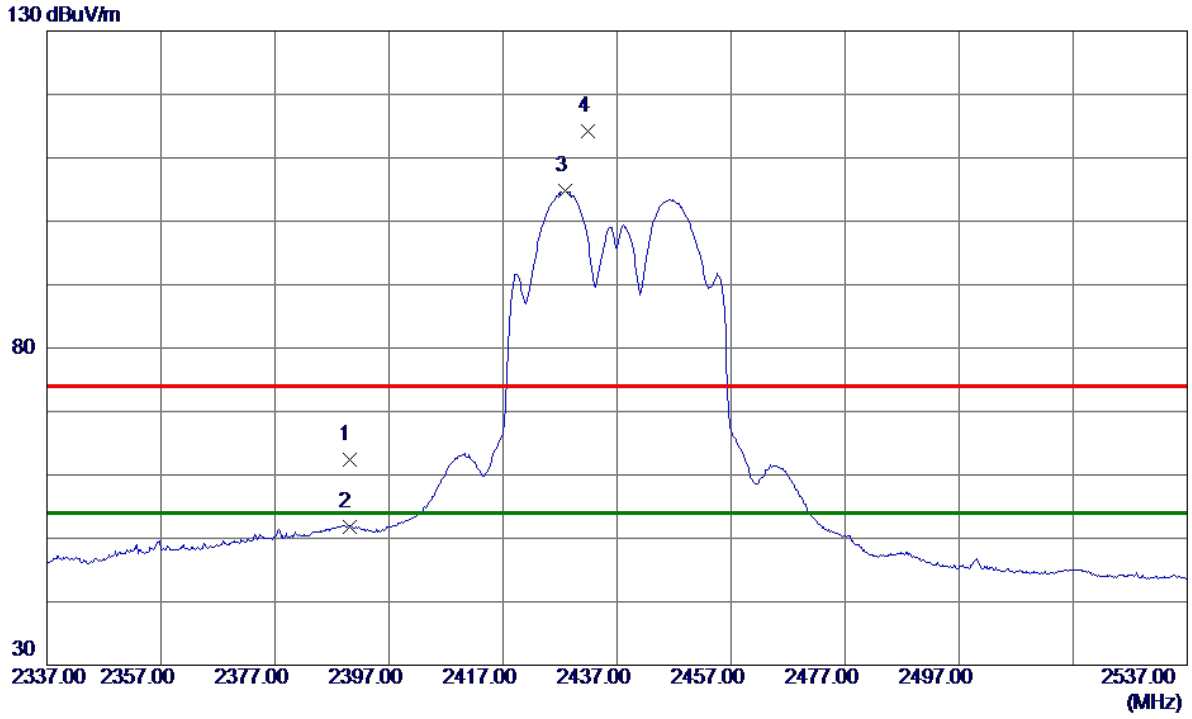

No.	Freq. MHz	Reading Level dBuV/m	Correct Factor dB	Measure ment dBuV/m	Limit dBuV/m	Margin dB	Detector	Comment
1	2390.0000	54.34	8.11	62.45	74.00	-11.55	Peak	
2	2390.0000	43.74	8.11	51.85	54.00	-2.15	AVG	
3 *	2427.9000	96.51	8.22	104.73	54.00	50.73	AVG	No Limit
4	2431.8000	106.00	8.23	114.23	74.00	40.23	Peak	No Limit

REMARKS:
 (1) Measurement Value = Reading Level + Correct Factor.
 (2) Margin Level = Measurement Value - Limit Value.

Test Mode: TX N-40M Mode 2437 MHz

Horizontal

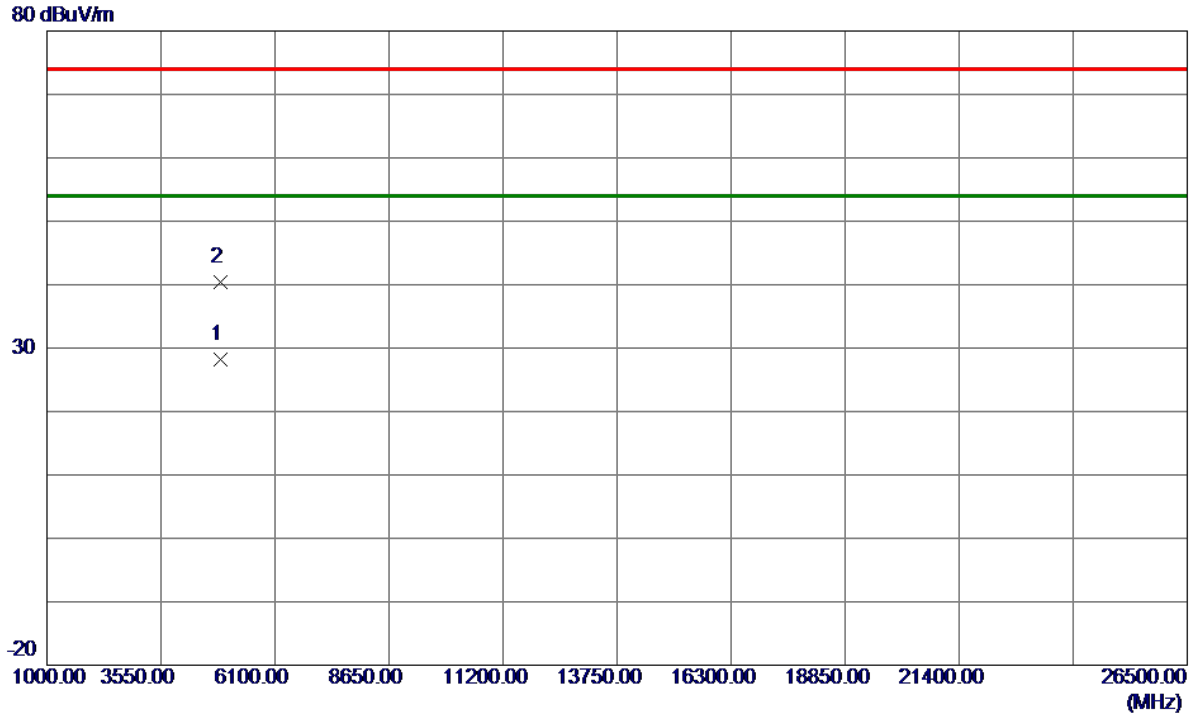

No.	Freq. MHz	Reading Level dBuV/m	Correct Factor dB	Measure ment dBuV/m	Limit dBuV/m	Margin dB	Detector	Comment
1 *	4880.4400	23.16	5.02	28.18	54.00	-25.82	AVG	
2	4882.5099	35.40	5.03	40.43	74.00	-33.57	Peak	

REMARKS:
 (1) Measurement Value = Reading Level + Correct Factor.
 (2) Margin Level = Measurement Value - Limit Value.

Test Mode: TX N-40M Mode 2452 MHz

Vertical

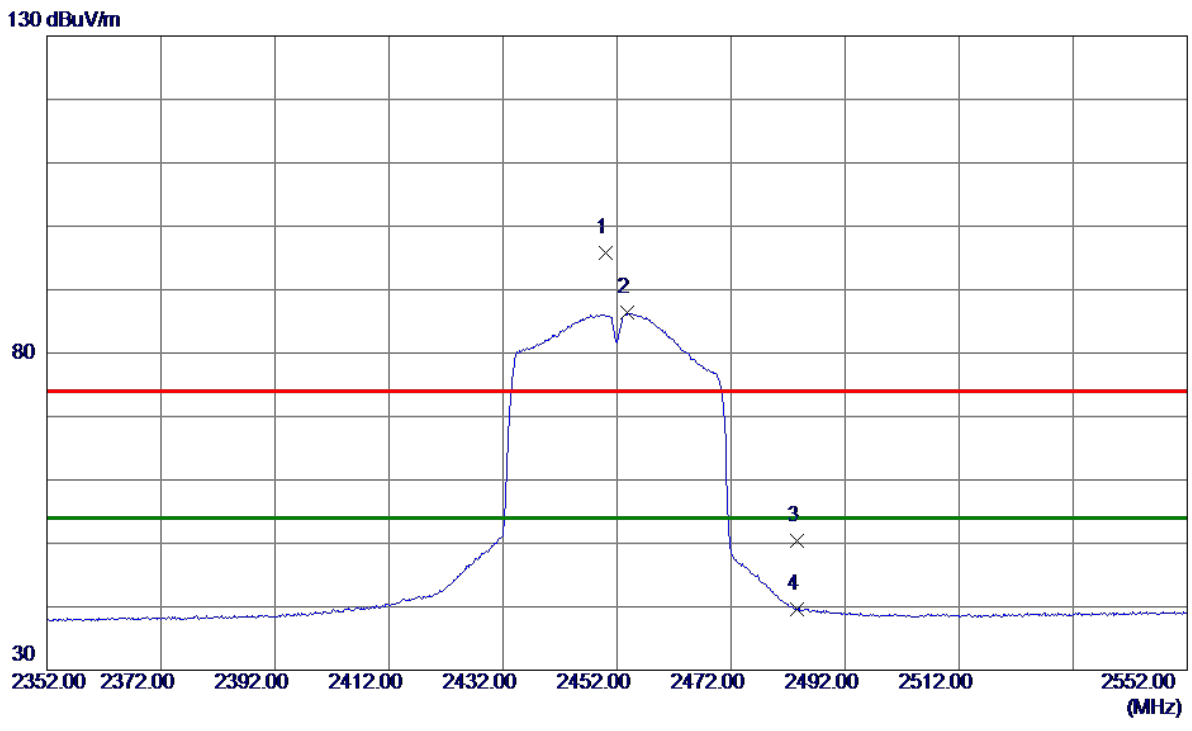

No.	Freq. MHz	Reading Level dBuV/m	Correct Factor dB	Measure ment dBuV/m	Limit dBuV/m	Margin dB	Detector	Comment
1	2449.9000	87.49	8.28	95.77	74.00	21.77	Peak	No Limit
2 *	2453.8000	78.04	8.30	86.34	54.00	32.34	AVG	No Limit
3	2483.5000	42.06	8.38	50.44	74.00	-23.56	Peak	
4	2483.5000	31.17	8.38	39.55	54.00	-14.45	AVG	

REMARKS:

- (1) Measurement Value = Reading Level + Correct Factor.
- (2) Margin Level = Measurement Value - Limit Value.

Test Mode: TX N-40M Mode 2452 MHz

Vertical

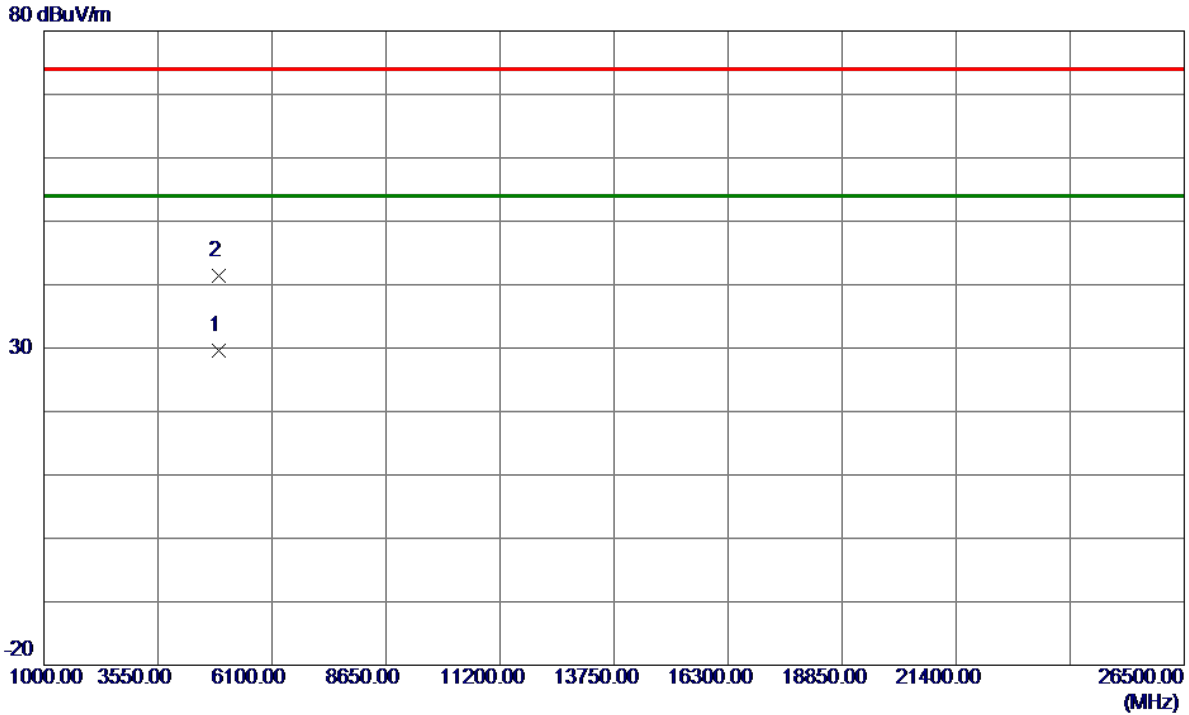

No.	Freq. MHz	Reading Level dBuV/m	Correct Factor dB	Measure ment dBuV/m	Limit dBuV/m	Margin dB	Detector	Comment
1 *	4901.6370	24.42	5.13	29.55	54.00	-24.45	AVG	
2	4903.4220	36.35	5.13	41.48	74.00	-32.52	Peak	

REMARKS:

- (1) Measurement Value = Reading Level + Correct Factor.
- (2) Margin Level = Measurement Value - Limit Value.

Test Mode: TX N-40M Mode 2452 MHz

Horizontal

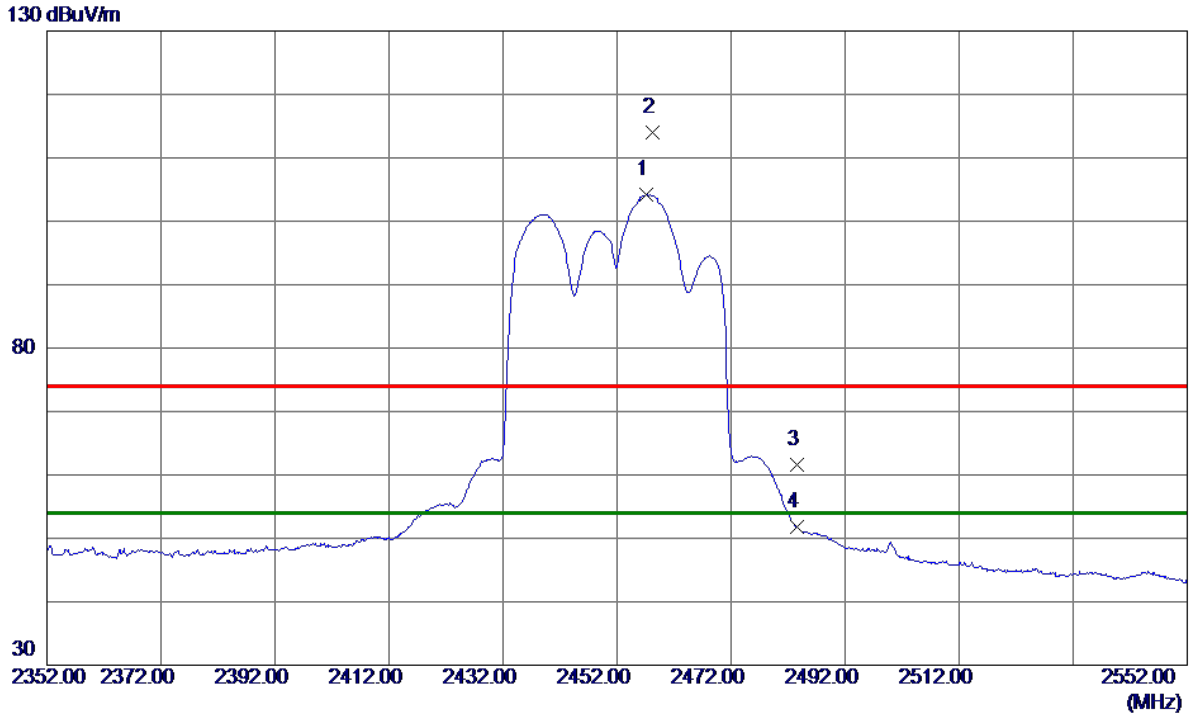

No.	Freq. MHz	Reading Level dBuV/m	Correct Factor dB	Measure ment dBuV/m	Limit dBuV/m	Margin dB	Detector	Comment
1 *	2457.2000	95.89	8.31	104.20	54.00	50.20	AVG	No Limit
2	2458.2000	105.76	8.31	114.07	74.00	40.07	Peak	No Limit
3	2483.5000	53.30	8.38	61.68	74.00	-12.32	Peak	
4	2483.5000	43.50	8.38	51.88	54.00	-2.12	AVG	

REMARKS:
 (1) Measurement Value = Reading Level + Correct Factor.
 (2) Margin Level = Measurement Value - Limit Value.

Test Mode: TX N-40M Mode 2452 MHz

Horizontal

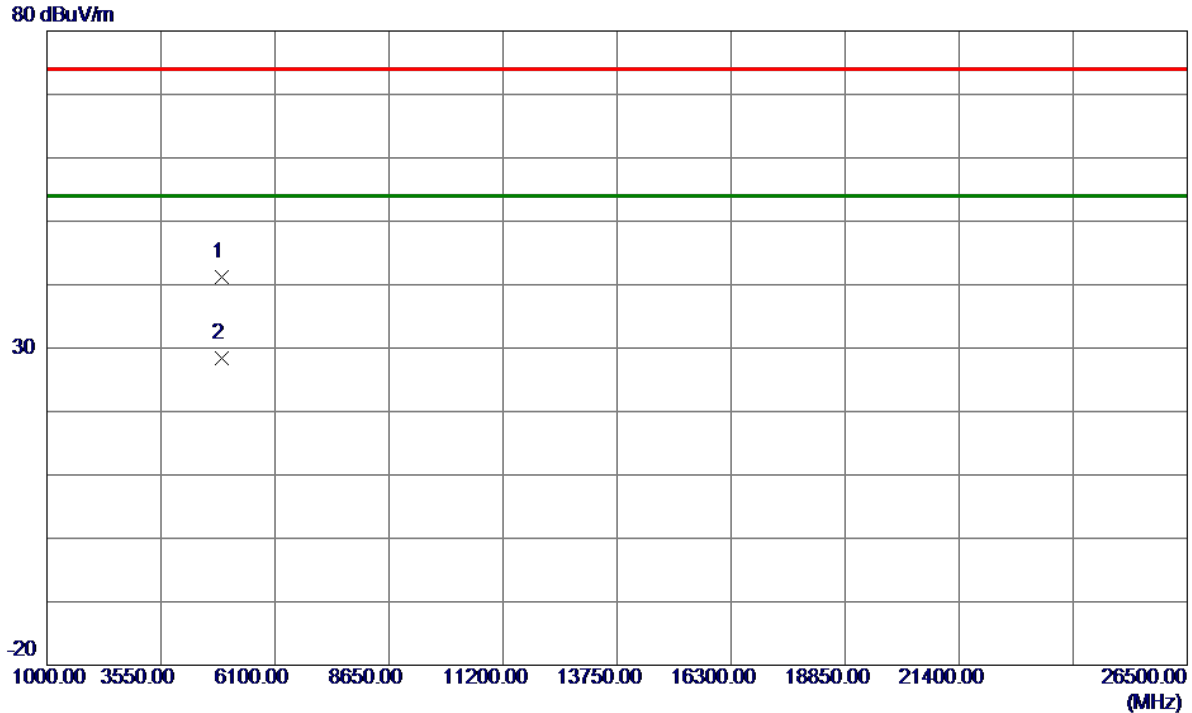

No.	Freq. MHz	Reading Level dBuV/m	Correct Factor dB	Measure ment dBuV/m	Limit dBuV/m	Margin dB	Detector	Comment
1	4905.7500	36.14	5.15	41.29	74.00	-32.71	Peak	
2 *	4913.3300	23.23	5.18	28.41	54.00	-25.59	AVG	

REMARKS:
 (1) Measurement Value = Reading Level + Correct Factor.
 (2) Margin Level = Measurement Value - Limit Value.

APPENDIX E - BANDWIDTH

Non-Beamforming

Test Mode	TX B Mode
-----------	-----------

Channel	Frequency (MHz)	6 dB Bandwidth (MHz)	6 dB Bandwidth Min. Limit (kHz)	Result
01	2412	7.03	500	Complies
06	2437	6.63	500	Complies
11	2462	7.05	500	Complies

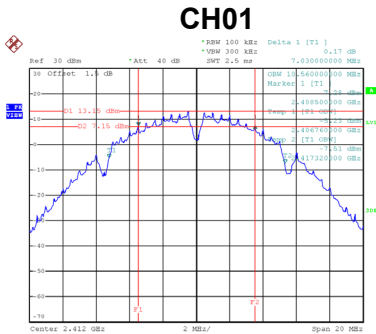

Date: 29_SEP.2019 16:53:04

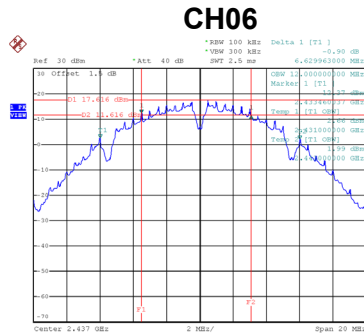

Date: 29_SEP.2019 16:55:20

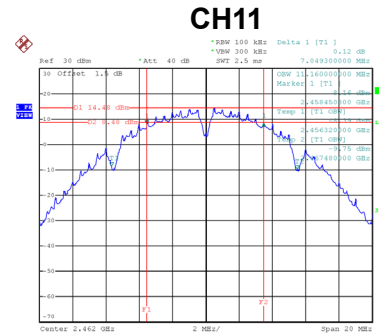

Date: 29_SEP.2019 16:57:03

Channel	Frequency (MHz)	99 % Emission Bandwidth (MHz)	Result
01	2412	11.70	Complies
06	2437	12.20	Complies
11	2462	11.70	Complies

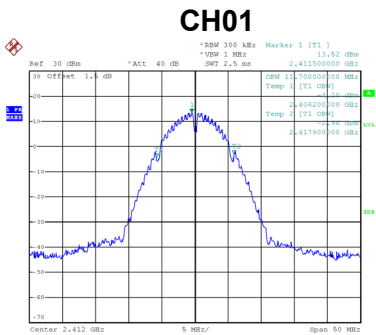

Date: 29_SEP.2019 18:42:36

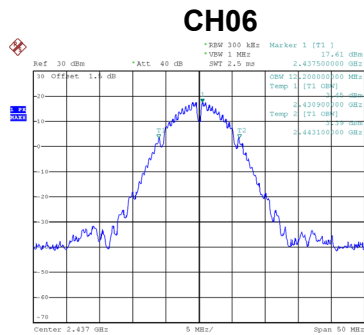

Date: 29_SEP.2019 18:43:26

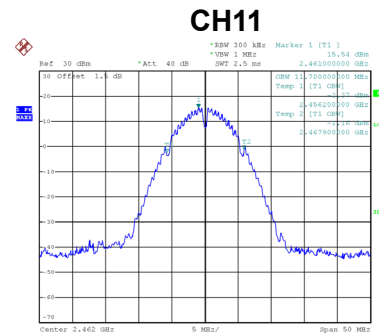

Date: 29_SEP.2019 18:44:09

Test Mode	TX G Mode
-----------	-----------

Channel	Frequency (MHz)	6 dB Bandwidth (MHz)	6 dB Bandwidth Min. Limit (kHz)	Result
01	2412	15.14	500	Complies
06	2437	15.44	500	Complies
11	2462	14.15	500	Complies

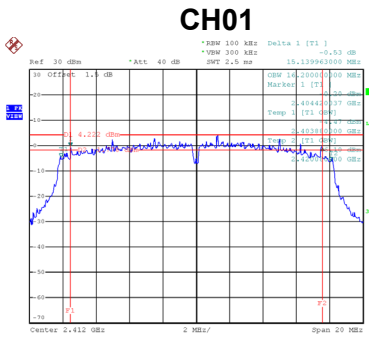

Date: 29_SEP.2019 16:58:49

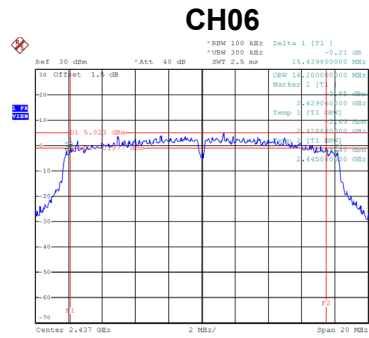

Date: 29_SEP.2019 17:01:04

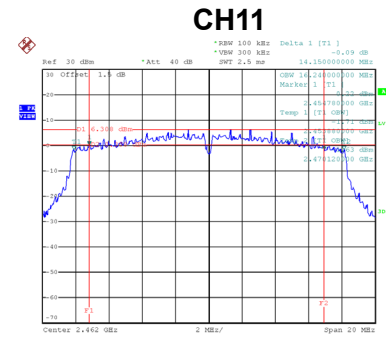

Date: 29_SEP.2019 17:02:39

Channel	Frequency (MHz)	99 % Emission Bandwidth (MHz)	Result
01	2412	16.40	Complies
06	2437	16.30	Complies
11	2462	16.20	Complies

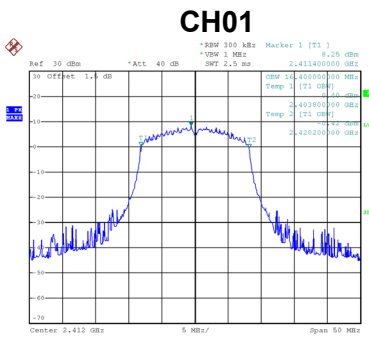

Date: 29_SEP.2019 18:45:13

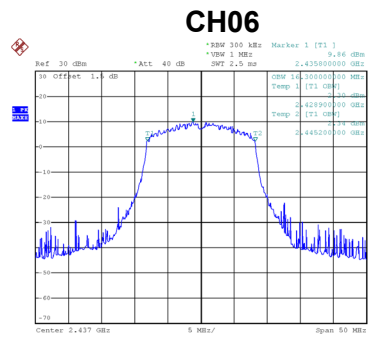

Date: 29_SEP.2019 18:45:59

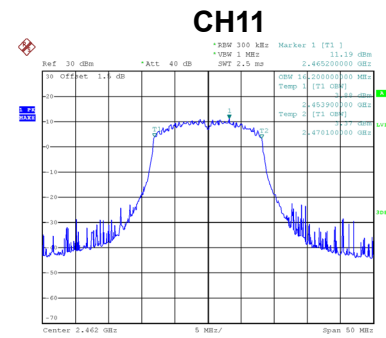

Date: 29_SEP.2019 18:46:40

Test Mode	TX N-20M Mode
-----------	---------------

Channel	Frequency (MHz)	6 dB Bandwidth (MHz)	6 dB Bandwidth Min. Limit (kHz)	Result
01	2412	15.06	500	Complies
06	2437	15.08	500	Complies
11	2462	12.63	500	Complies

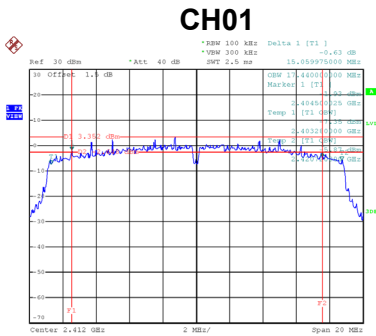

Date: 19_JUL_2019 11:44:01

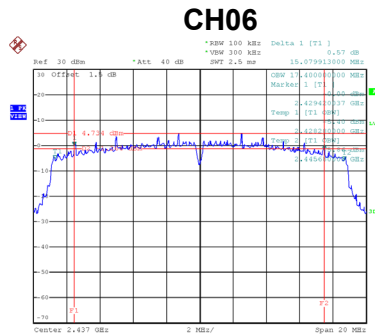

Date: 19_JUL_2019 11:45:12

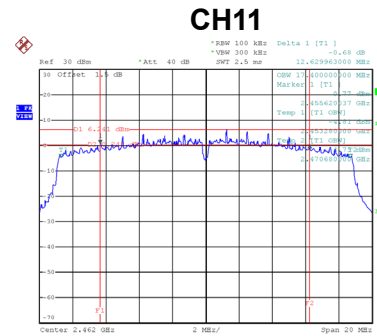

Date: 19_JUL_2019 11:47:12

Channel	Frequency (MHz)	99 % Emission Bandwidth (MHz)	Result
01	2412	17.50	Complies
06	2437	17.50	Complies
11	2462	17.40	Complies

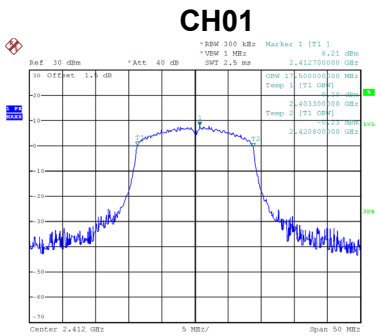

Date: 19_JUL_2019 13:57:34

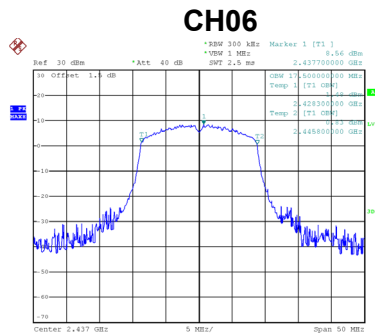

Date: 19_JUL_2019 13:58:15

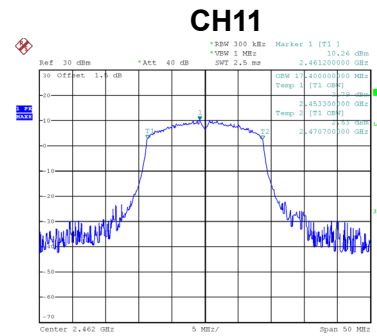

Date: 19_JUL_2019 13:59:09

Test Mode	TX N-40M Mode
-----------	---------------

Channel	Frequency (MHz)	6 dB Bandwidth (MHz)	6 dB Bandwidth Min. Limit (kHz)	Result
03	2422	30.07	500	Complies
06	2437	33.96	500	Complies
09	2452	35.08	500	Complies

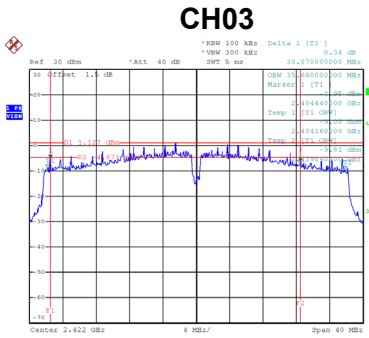

Date: 19_JUL.2019 11:53:29

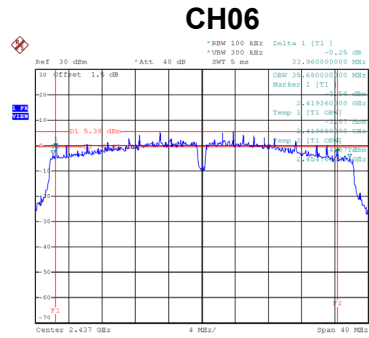

Date: 19_JUL.2019 11:55:19

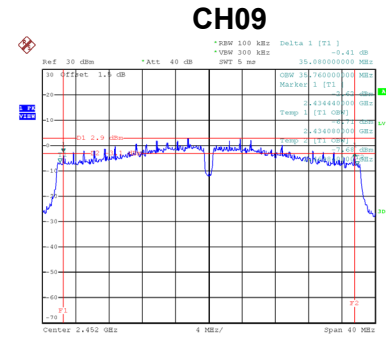

Date: 19_JUL.2019 11:57:54

Channel	Frequency (MHz)	99 % Emission Bandwidth (MHz)	Result
03	2422	36.40	Complies
06	2437	36.40	Complies
09	2452	36.40	Complies

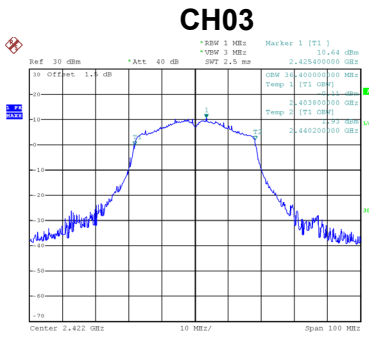

Date: 19_JUL.2019 14:02:27

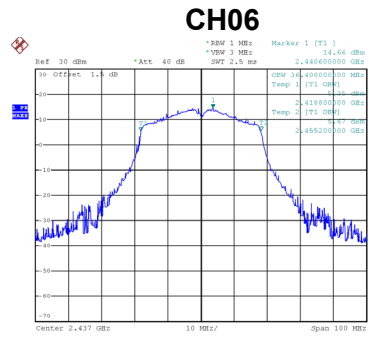

Date: 19_JUL.2019 14:01:47

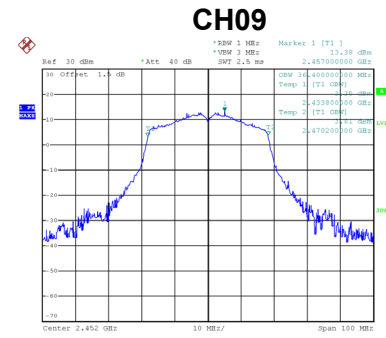

Date: 19_JUL.2019 14:03:18

APPENDIX F - MAXIMUM OUTPUT POWER

Non-Beamforming

Test Mode	TX B Mode_Ant. 1
------------------	------------------

Channel	Frequency (MHz)	Output Power (dBm)	Output Power (W)	Max. Limit (dBm)	Max. Limit (W)	Result
01	2412	24.13	0.2588	30.00	1.0000	Complies
06	2437	25.13	0.3258	30.00	1.0000	Complies
11	2462	24.88	0.3076	30.00	1.0000	Complies

Test Mode	TX B Mode_Ant. 2
------------------	------------------

Channel	Frequency (MHz)	Output Power (dBm)	Output Power (W)	Max. Limit (dBm)	Max. Limit (W)	Result
01	2412	23.82	0.2410	30.00	1.0000	Complies
06	2437	25.38	0.3451	30.00	1.0000	Complies
11	2462	24.59	0.2877	30.00	1.0000	Complies

Test Mode	TX B Mode_Ant. 3
------------------	------------------

Channel	Frequency (MHz)	Output Power (dBm)	Output Power (W)	Max. Limit (dBm)	Max. Limit (W)	Result
01	2412	24.07	0.2553	30.00	1.0000	Complies
06	2437	25.07	0.3214	30.00	1.0000	Complies
11	2462	24.97	0.3141	30.00	1.0000	Complies

Test Mode	TX B Mode_Total
------------------	-----------------

Channel	Frequency (MHz)	Output Power (dBm)	Output Power (W)	Max. Limit (dBm)	Max. Limit (W)	Result
01	2412	28.78	0.7551	30.00	1.0000	Complies
06	2437	29.97	0.9923	30.00	1.0000	Complies
11	2462	29.59	0.9094	30.00	1.0000	Complies

Test Mode	TX G Mode_Ant. 1
-----------	------------------

Channel	Frequency (MHz)	Output Power (dBm)	Output Power (W)	Max. Limit (dBm)	Max. Limit (W)	Result
01	2412	24.91	0.3097	30.00	1.0000	Complies
06	2437	24.88	0.3076	30.00	1.0000	Complies
11	2462	25.06	0.3206	30.00	1.0000	Complies

Test Mode	TX G Mode_Ant. 2
-----------	------------------

Channel	Frequency (MHz)	Output Power (dBm)	Output Power (W)	Max. Limit (dBm)	Max. Limit (W)	Result
01	2412	24.77	0.2999	30.00	1.0000	Complies
06	2437	24.76	0.2992	30.00	1.0000	Complies
11	2462	25.25	0.3350	30.00	1.0000	Complies

Test Mode	TX G Mode_Ant. 3
-----------	------------------

Channel	Frequency (MHz)	Output Power (dBm)	Output Power (W)	Max. Limit (dBm)	Max. Limit (W)	Result
01	2412	24.91	0.3097	30.00	1.0000	Complies
06	2437	24.82	0.3034	30.00	1.0000	Complies
11	2462	25.21	0.3319	30.00	1.0000	Complies

Test Mode	TX G Mode_Total
-----------	-----------------

Channel	Frequency (MHz)	Output Power (dBm)	Output Power (W)	Max. Limit (dBm)	Max. Limit (W)	Result
01	2412	29.64	0.9194	30.00	1.0000	Complies
06	2437	29.59	0.9102	30.00	1.0000	Complies
11	2462	29.95	0.9875	30.00	1.0000	Complies

Test Mode	TX N-20M Mode_Ant. 1
-----------	----------------------

Channel	Frequency (MHz)	Output Power (dBm)	Output Power (W)	Max. Limit (dBm)	Max. Limit (W)	Result
01	2412	23.14	0.2061	30.00	1.0000	Complies
06	2437	25.53	0.3573	30.00	1.0000	Complies
11	2462	24.85	0.3055	30.00	1.0000	Complies

Test Mode	TX N-20M Mode_Ant. 2
-----------	----------------------

Channel	Frequency (MHz)	Output Power (dBm)	Output Power (W)	Max. Limit (dBm)	Max. Limit (W)	Result
01	2412	23.70	0.2344	30.00	1.0000	Complies
06	2437	24.31	0.2698	30.00	1.0000	Complies
11	2462	25.33	0.3412	30.00	1.0000	Complies

Test Mode	TX N-20M Mode_Ant. 3
-----------	----------------------

Channel	Frequency (MHz)	Output Power (dBm)	Output Power (W)	Max. Limit (dBm)	Max. Limit (W)	Result
01	2412	23.42	0.2198	30.00	1.0000	Complies
06	2437	23.85	0.2427	30.00	1.0000	Complies
11	2462	25.46	0.3516	30.00	1.0000	Complies

Test Mode	TX N-20M Mode_Total
-----------	---------------------

Channel	Frequency (MHz)	Output Power (dBm)	Output Power (W)	Max. Limit (dBm)	Max. Limit (W)	Result
01	2412	28.20	0.6603	30.00	1.0000	Complies
06	2437	29.39	0.8697	30.00	1.0000	Complies
11	2462	29.99	0.9982	30.00	1.0000	Complies

Test Mode	TX N-40M Mode_Ant. 1
-----------	----------------------

Channel	Frequency (MHz)	Output Power (dBm)	Output Power (W)	Max. Limit (dBm)	Max. Limit (W)	Result
03	2422	20.82	0.1208	30.00	1.0000	Complies
06	2437	25.23	0.3334	30.00	1.0000	Complies
09	2452	23.69	0.2339	30.00	1.0000	Complies

Test Mode	TX N-40M Mode_Ant. 2
-----------	----------------------

Channel	Frequency (MHz)	Output Power (dBm)	Output Power (W)	Max. Limit (dBm)	Max. Limit (W)	Result
03	2422	21.04	0.1271	30.00	1.0000	Complies
06	2437	25.22	0.3327	30.00	1.0000	Complies
09	2452	23.77	0.2382	30.00	1.0000	Complies

Test Mode	TX N-40M Mode_Ant. 3
-----------	----------------------

Channel	Frequency (MHz)	Output Power (dBm)	Output Power (W)	Max. Limit (dBm)	Max. Limit (W)	Result
03	2422	21.11	0.1291	30.00	1.0000	Complies
06	2437	24.95	0.3126	30.00	1.0000	Complies
09	2452	24.09	0.2564	30.00	1.0000	Complies

Test Mode	TX N-40M Mode_Total
-----------	---------------------

Channel	Frequency (MHz)	Output Power (dBm)	Output Power (W)	Max. Limit (dBm)	Max. Limit (W)	Result
03	2422	25.76	0.3770	30.00	1.0000	Complies
06	2437	29.91	0.9787	30.00	1.0000	Complies
09	2452	28.62	0.7286	30.00	1.0000	Complies

Beamforming

Test Mode	TX N-20M Mode_Ant. 1
------------------	----------------------

Channel	Frequency (MHz)	Output Power (dBm)	Output Power (W)	Max. Limit (dBm)	Max. Limit (W)	Result
01	2412	23.24	0.2109	28.50	0.7079	Complies
06	2437	23.88	0.2443	28.50	0.7079	Complies
11	2462	22.98	0.1986	28.50	0.7079	Complies

Test Mode	TX N-20M Mode_Ant. 2
------------------	----------------------

Channel	Frequency (MHz)	Output Power (dBm)	Output Power (W)	Max. Limit (dBm)	Max. Limit (W)	Result
01	2412	23.33	0.2153	28.50	0.7079	Complies
06	2437	23.08	0.2032	28.50	0.7079	Complies
11	2462	23.31	0.2143	28.50	0.7079	Complies

Test Mode	TX N-20M Mode_Ant. 3
------------------	----------------------

Channel	Frequency (MHz)	Output Power (dBm)	Output Power (W)	Max. Limit (dBm)	Max. Limit (W)	Result
01	2412	23.48	0.2228	28.50	0.7079	Complies
06	2437	22.66	0.1845	28.50	0.7079	Complies
11	2462	24.36	0.2729	28.50	0.7079	Complies

Test Mode	TX N-20M Mode_Total
------------------	---------------------

Channel	Frequency (MHz)	Output Power (dBm)	Output Power (W)	Max. Limit (dBm)	Max. Limit (W)	Result
01	2412	28.12	0.6490	28.50	0.7079	Complies
06	2437	28.01	0.6321	28.50	0.7079	Complies
11	2462	28.36	0.6858	28.50	0.7079	Complies

Test Mode	TX N-40M Mode_Ant. 1
-----------	----------------------

Channel	Frequency (MHz)	Output Power (dBm)	Output Power (W)	Max. Limit (dBm)	Max. Limit (W)	Result
03	2422	20.76	0.1191	28.50	0.7079	Complies
06	2437	23.67	0.2328	28.50	0.7079	Complies
09	2452	23.12	0.2051	28.50	0.7079	Complies

Test Mode	TX N-40M Mode_Ant. 2
-----------	----------------------

Channel	Frequency (MHz)	Output Power (dBm)	Output Power (W)	Max. Limit (dBm)	Max. Limit (W)	Result
03	2422	21.04	0.1271	28.50	0.7079	Complies
06	2437	23.57	0.2275	28.50	0.7079	Complies
09	2452	23.35	0.2163	28.50	0.7079	Complies

Test Mode	TX N-40M Mode_Ant. 3
-----------	----------------------

Channel	Frequency (MHz)	Output Power (dBm)	Output Power (W)	Max. Limit (dBm)	Max. Limit (W)	Result
03	2422	21.07	0.1279	28.50	0.7079	Complies
06	2437	23.48	0.2228	28.50	0.7079	Complies
09	2452	23.68	0.2333	28.50	0.7079	Complies

Test Mode	TX N-40M Mode_Total
-----------	---------------------

Channel	Frequency (MHz)	Output Power (dBm)	Output Power (W)	Max. Limit (dBm)	Max. Limit (W)	Result
03	2422	25.73	0.3741	28.50	0.7079	Complies
06	2437	28.35	0.6832	28.50	0.7079	Complies
09	2452	28.16	0.6547	28.50	0.7079	Complies

APPENDIX G - CONDUCTED SPURIOUS EMISSIONS

Non-Beamforming

Test Mode TX B Mode_Ant. 1

Bandedge-CH01

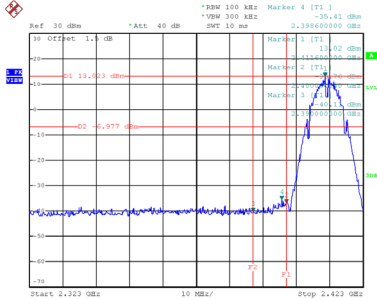

Date: 29_SEP.2019 16:53:11

Bandedge-CH11

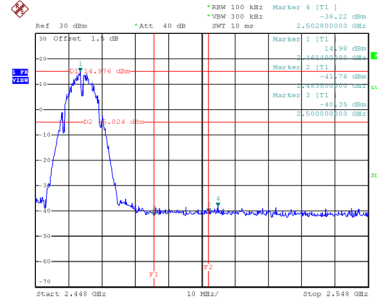

Date: 29_SEP.2019 16:57:10

CH01 – 10th Harmonic of the fundamental frequency

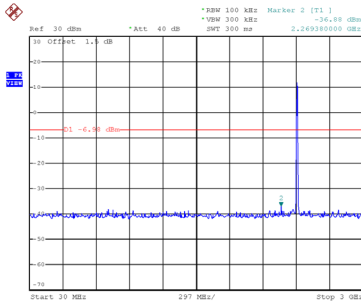

Date: 29_SEP.2019 16:53:24

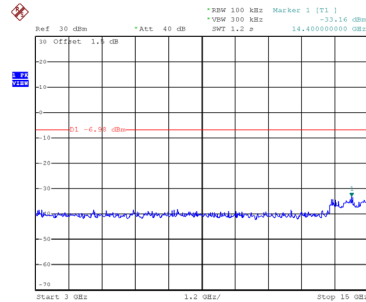

Date: 29_SEP.2019 16:53:31

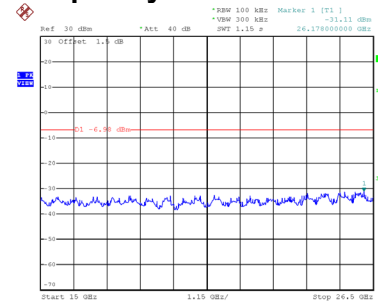

Date: 29_SEP.2019 16:53:38

CH06 – 10th Harmonic of the fundamental frequency

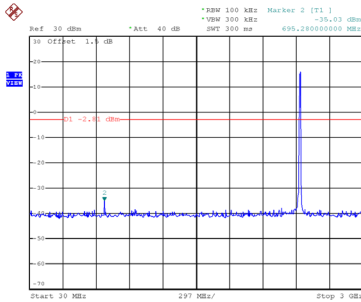

Date: 29_SEP.2019 16:55:40

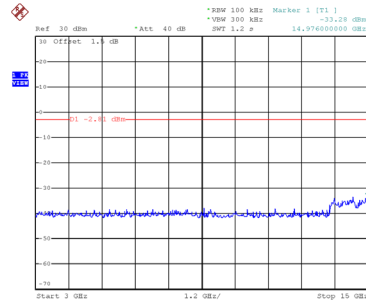

Date: 29_SEP.2019 16:55:47

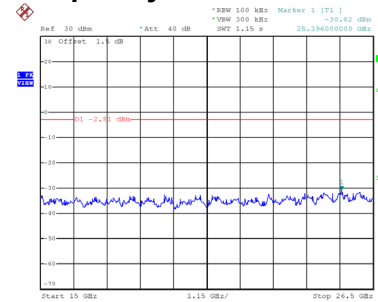

Date: 29_SEP.2019 16:55:54

CH11 – 10th Harmonic of the fundamental frequency

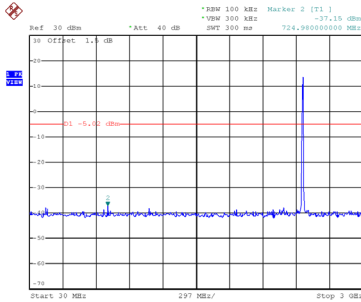

Date: 29_SEP.2019 16:57:23

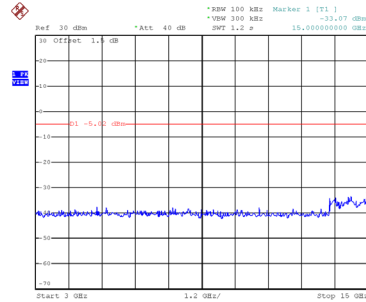

Date: 29_SEP.2019 16:57:30

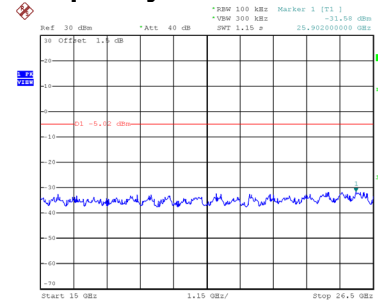

Date: 29_SEP.2019 16:57:37

Test Mode TX B Mode_Ant. 2

Bandedge-CH01

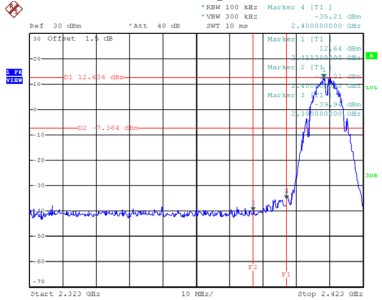

Date: 29_SEP.2019 17:26:55

Bandedge-CH11

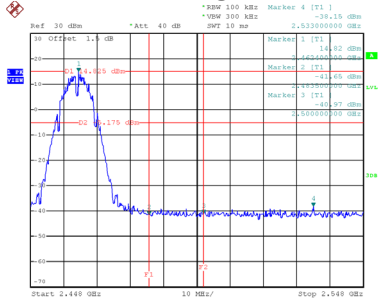

Date: 29_SEP.2019 17:30:19

CH01 – 10th Harmonic of the fundamental frequency

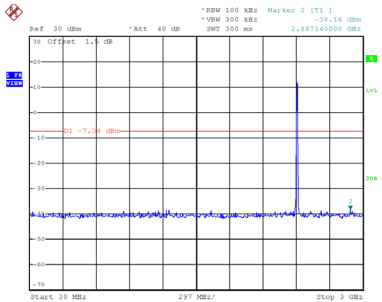

Date: 29_SEP.2019 17:27:08

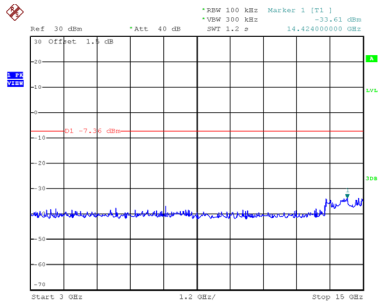

Date: 29_SEP.2019 17:27:15

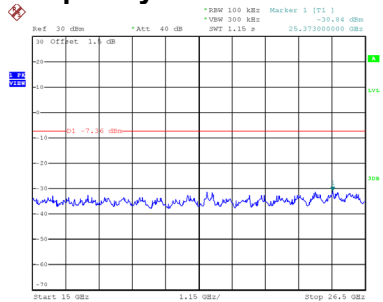

Date: 29_SEP.2019 17:27:22

CH06 – 10th Harmonic of the fundamental frequency

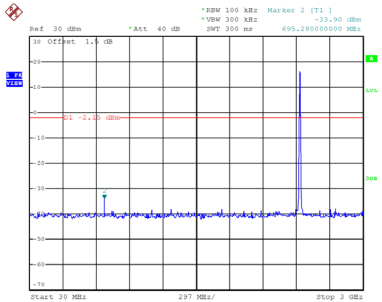

Date: 29_SEP.2019 17:28:55

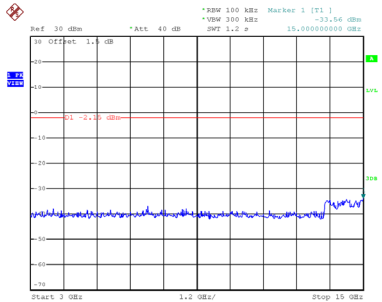

Date: 29_SEP.2019 17:29:02

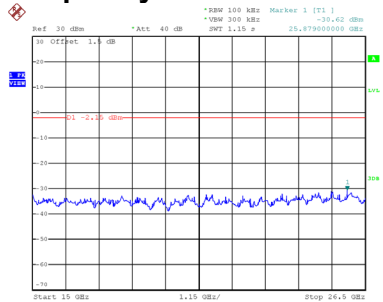

Date: 29_SEP.2019 17:29:09

CH11 – 10th Harmonic of the fundamental frequency

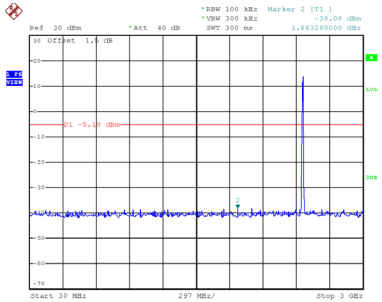

Date: 29_SEP.2019 17:30:32

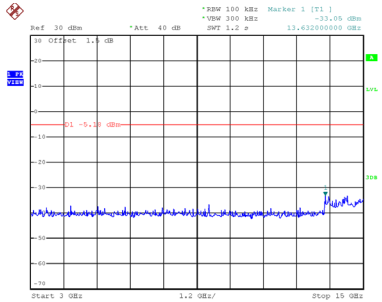

Date: 29_SEP.2019 17:30:39

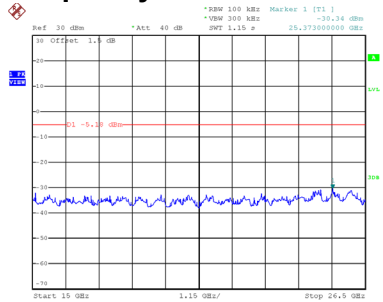

Date: 29_SEP.2019 17:30:46