



FCC Radio Test Report

FCC ID : TVE-240602
Equipment : Secured Wireless Access Point
Brand Name : FORTINET
Model Name : FortiAP 241Kxxxxxxxxx, FAP-241Kxxxxxxxxx, FORTIAP-241Kxxxxxxxxx (Where "x" can be used as "A-Z", or "0-9", or "-", or blank for software changes or marketing purposes only)
Applicant : Fortinet, Inc.
909 Kifer Road, Sunnyvale, CA 94086, USA
Manufacturer : Fortinet, Inc.
909 Kifer Road, Sunnyvale, CA 94086, USA
Standard : 47 CFR FCC Part 15.247

The product was received on Apr. 23, 2024, and testing was started from May 06, 2024 and completed on Jul. 03, 2024. We, SPORTON INTERNATIONAL INC. Hsinhua Laboratory, would like to declare that the tested sample has been evaluated in accordance with the procedures given in ANSI C63.10-2013 and shown compliance with the applicable technical standards.

The test results in this report apply exclusively to the tested model / sample. Without written approval of SPORTON INTERNATIONAL INC. Hsinhua Laboratory, the test report shall not be reproduced except in full.

Approved by: Jackson Tsai

SPORTON INTERNATIONAL INC. Hsinhua Laboratory

No.52, Huaya 1st Rd., Guishan Dist., Taoyuan City 333411, Taiwan (R.O.C.)



Table of Contents

HISTORY OF THIS TEST REPORT3

SUMMARY OF TEST RESULT4

1 GENERAL DESCRIPTION5

1.1 Information.....5

1.2 Testing Applied Standards9

1.3 Testing Location Information9

1.4 Measurement Uncertainty9

2 TEST CONFIGURATION OF EUT.....10

2.1 Test Channel Mode10

2.2 The Worst Case Measurement Configuration.....11

2.3 Accessories12

2.4 Support Equipment.....12

2.5 Test Setup Diagram13

3 TRANSMITTER TEST RESULT14

3.1 AC Power-line Conducted Emissions14

3.2 DTS Bandwidth.....16

3.3 Maximum Conducted Output Power17

3.4 Power Spectral Density19

3.5 Emissions in Non-restricted Frequency Bands20

3.6 Emissions in Restricted Frequency Bands.....21

4 TEST EQUIPMENT AND CALIBRATION DATA.....25

APPENDIX A. TEST RESULTS OF AC POWER-LINE CONDUCTED EMISSIONS

APPENDIX B. TEST RESULTS OF DTS BANDWIDTH

APPENDIX C. TEST RESULTS OF MAXIMUM CONDUCTED OUTPUT POWER

APPENDIX D. TEST RESULTS OF POWER SPECTRAL DENSITY

APPENDIX E. TEST RESULTS OF EMISSIONS IN NON-RESTRICTED FREQUENCY BANDS

APPENDIX F. TEST RESULTS OF EMISSIONS IN RESTRICTED FREQUENCY BANDS

APPENDIX G. TEST RESULTS OF RADIATED EMISSION CO-LOCATION

APPENDIX H. TEST PHOTOS

PHOTOGRAPHS OF EUT V01



History of this test report

Report No.	Version	Description	Issued Date
FR411229AL	01	Initial issue of report	Jul. 16, 2024



Summary of Test Result

Report Clause	Ref.Std. Clause	Test Items	Result (PASS/FAIL)	Remark
1.1.2	15.203	Antenna Requirement	PASS	-
3.1	15.207	AC Power-line Conducted Emissions	PASS	-
3.2	15.247(a)	DTS Bandwidth	PASS	-
3.3	15.247(b)	Maximum Conducted Output Power	PASS	-
3.4	15.247(e)	Power Spectral Density	PASS	-
3.5	15.247(d)	Emissions in Non-restricted Frequency Bands	PASS	-
3.6	15.247(d)	Emissions in Restricted Frequency Bands	PASS	-

Declaration of Conformity:
The test results with all measurement uncertainty excluded are presented in accordance with the regulation limits or requirements declared by manufacturers.
Comments and explanations:
None

Reviewed by: Barry Hsiao

Report Producer: Julie Tseng



1 General Description

1.1 Information

Radio 3 (Scan radio) is only RX function.

1.1.1 RF General Information

Frequency Range (MHz)	Bluetooth Mode	Ch. Frequency (MHz)	Channel Number
2400-2483.5	LE	2402-2480	0-39 [40]

Band	Mode	BWch (MHz)	Nant
2.4-2.4835GHz	BT-LE(125kbps)	1.0	1TX
2.4-2.4835GHz	BT-LE(500kbps)	1.0	1TX
2.4-2.4835GHz	BT-LE(1Mbps)	1.0	1TX
2.4-2.4835GHz	BT-LE(2Mbps)	2.0	1TX

Note:

- ♦ Bluetooth LE uses a GFSK (125k/500k/1Mbps/2Mbps) modulation.
- ♦ BWch is the nominal channel bandwidth.
- ♦ Bluetooth LE 125k/500k/1Mbps uses the same modulation, and 1Mbps was found to be the worst case scenario which was performed full test and recorded in this test report.

1.1.2 Antenna Information

Ant.	Port	Brand	Model Name	Antenna Type	Connector	Support
1	1	EnRack	7102A1242000	PIFA	I-PEX	2.4G+5G+5.9G
2	2	EnRack	7102A1241000	PIFA	I-PEX	2.4G+5G+5.9G
3	1	EnRack	7102A1244000	PIFA	I-PEX	2.4G+5G+5.9G +6G
4	2	EnRack	7102A1243000	PIFA	I-PEX	2.4G+5G+5.9G +6G
5	1	AWAN	7102A1240000	Alford Loop	I-PEX	6G
6	2	AWAN	7102A1240000	Alford Loop	I-PEX	6G
7	1	AWAN	7102A1240000	Dipole	I-PEX	BT+Zigbee

Ant.	Port	Gain (dBi)						Remark	
		2.4G	5G	5.9G	6G	BT	Zigbee		
1	1	5.11	5.22	5.11	-	-	-	Radio1 2.4G only 2*2	Radio2 5G/5.9G 2*2
2	2	5.19	5.32	4.79	-	-	-		
3	1	4.97	5.35	5.40	5.48	-	-	Radio3 (Scan radio) 2.4G/5G/5.9G/6G 2*2	
4	2	4.69	5.43	5.13	5.37	-	-		
5	1	-	-	-	5.53	-	-	Radio2 6G 2*2	
6	2	-	-	-	5.58	-	-		
7	1	-	-	-	-	5.00	5.00	-	

Note 1: The EUT has seven antennas.

Note 2: Directional gain information

	Maximum Output Power	Power Spectral Density
Non-BF	Directional gain = Max.gain + array gain. For power measurements on IEEE 802.11 devices Array Gain = 0 dB (i.e., no array gain) for N ANT ≤ 4	$DirectionalGain = 10 \cdot \log \left[\frac{\sum_{j=1}^{N_{ANT}} \left\{ \sum_{i=1}^{N_{ANT}} g_{j,i} \right\}^2}{N_{ANT}} \right]$
BF	$DirectionalGain = 10 \cdot \log \left[\frac{\sum_{j=1}^{N_{ANT}} \left\{ \sum_{i=1}^{N_{ANT}} g_{j,i} \right\}^2}{N_{ANT}} \right]$	$DirectionalGain = 10 \cdot \log \left[\frac{\sum_{j=1}^{N_{ANT}} \left\{ \sum_{i=1}^{N_{ANT}} g_{j,i} \right\}^2}{N_{ANT}} \right]$



For 2.4GHz function:

< Radio 1 >

For IEEE 802.11b/g/n/VHT/ax/be mode (2TX/2RX)

Ant.1 (port 1), Ant.2 (port 2) could transmit/receive simultaneously.

< Radio 3 > < Scan >

For IEEE 802.11b/g/n/VHT/ax mode (2RX)

Ant.3 (port 1), Ant.4 (port 2) can be used as receiving.

For 5GHz function:

< Radio 2 >

For IEEE 802.11a/n/ac/ax/be mode (2TX/2RX)

Ant.1 (port 1), Ant.2 (port 2) could transmit/receive simultaneously.

< Radio 3 > < Scan >

For IEEE 802.11a/n/ac/ax mode (2RX)

Ant.3 (port 1), Ant.4 (port 2) can be used as receiving.

For 6GHz function:

< Radio 2 >

For IEEE 802.11ax/be mode (2TX/2RX)

Ant.5 (port 1), Ant.6 (port 2) could transmit/receive simultaneously.

< Radio 3 > < Scan >

For IEEE 802.11ax mode (2RX)

Ant.3 (port 1), Ant.4 (port 2) can be used as receiving.

For Bluetooth / Zigbee function:

For Bluetooth mode (1TX/1RX)

Only Ant.7 can be used as transmitting/receiving.



1.1.3 EUT Information

Operational Condition			
EUT Power Type	From AC Adapter / PoE		
EUT Function	<input checked="" type="checkbox"/> Point-to-multipoint	<input type="checkbox"/> Point-to-point	
Type of EUT			
<input checked="" type="checkbox"/>	Stand-alone		
<input type="checkbox"/>	Combined (EUT where the radio part is fully integrated within another device)		
	Combined Equipment - Brand Name / Model No.:	...	
<input type="checkbox"/>	Plug-in radio (EUT intended for a variety of host systems)		
	Host System - Brand Name / Model No.:	...	
<input type="checkbox"/>	Other:		

1.1.4 Mode Test Duty Cycle

Mode	DC	DCF (dB)	T (s)	VBW (Hz)_1/T
BT-LE(1Mbps)	1	0	n/a (DC>=0.98)	n/a (DC>=0.98)
BT-LE(2Mbps)	1	0	n/a (DC>=0.98)	n/a (DC>=0.98)

Note. If DC < 0.98, the DCF was added while measuring Output power and PSD.

1.1.5 Table for Multiple Listing

The brand/model names in the following table are all refer to the identical product.

Brand Name	Model Name	Description
FORTINET	FortiAP 241Kxxxxxxx, FAP-241Kxxxxxxx, FORTIAP-241Kxxxxxxx (Where "x" can be used as "A-Z", or "0-9", or "-", or blank for software changes or marketing purposes only)	All the models are identical, the difference model for difference brand served as marketing strategy.

From the above models, model: FAP-241K was selected as representative model for the test and its data was recorded in this report.

1.2 Testing Applied Standards

According to the specifications of the manufacturer, the EUT must comply with the requirements of the following standards:

- ♦ 47 CFR FCC Part 15
- ♦ ANSI C63.10-2013

The following reference test guidance is not within the scope of accreditation of TAF:

- ♦ KDB 558074 D01 v05r02
- ♦ KDB 414788 D01 v01r01

1.3 Testing Location Information

Test Lab. : Sporton International Inc. Hsinhua Laboratory				
<input checked="" type="checkbox"/>	Hsinhua (TAF: 3785)	ADD: No.52, Huaya 1st Rd., Guishan Dist., Taoyuan City 333411, Taiwan (R.O.C.)		
		TEL: 886-3-327-3456	FAX: 886-3-327-0973	
Test site Designation No. TW3785 with FCC.				
Test Condition	Test Site No.	Test Engineer	Test Environment	Test Date
AC Conduction	CO04-HY	Daniel Lin	23.8~24.9°C / 50~53%	03/Jul/2024
RF Conducted	TH07-HY	Xun Hsieh	22.8~23.9°C / 50~56%	06/May/2024~30/May/2024
<input checked="" type="checkbox"/>	Wenhua 3rd. (TAF: 3785)	ADD: No. 58, Aly. 75, Ln. 564, Wenhua 3rd Rd., Guishan Dist. Taoyuan City 333, Taiwan (R.O.C.)		
		TEL: 886-3-327-0868		
Test site Designation No. TW0036 with FCC.				
Test Condition	Test Site No.	Test Engineer	Test Environment	Test Date
Radiated	03CH24-HY	Vasari Huang	22.5~22.6°C / 54~59%	12/May/2024~25/May/2024
Radiated (Co-location)	03CH26-HY	Billy Wang	22.9~23.2°C / 59~60%	28/May/2024

1.4 Measurement Uncertainty

ISO/IEC 17025 requires that an estimate of the measurement uncertainties associated with the emissions test results be included in the report. The measurement uncertainties given below are based on a 95% confidence level (based on a coverage factor (k=2))

Test Items	Uncertainty	Remark
AC Power-line Conducted Emissions	4.53 dB	Confidence levels of 95%
Bandwidth	3 MHz	Confidence levels of 95%
Maximum Conducted Output Power	2 dB	Confidence levels of 95%
Power Spectral Density	2 dB	Confidence levels of 95%
Emissions in Non-restricted Frequency Bands	0.14 dB	Confidence levels of 95%
Emissions in Restricted Frequency Bands	4.8 dB	Confidence levels of 95%
Temperature	0.41 °C	Confidence levels of 95%
Humidity	3.4 %	Confidence levels of 95%



2 Test Configuration of EUT



2.1 Test Channel Mode

Test Software Version	PuTTY Release 0.62
Mode	Power Setting
BT-LE(1Mbps)	-
2402MHz	200
2440MHz	200
2480MHz	200
BT-LE(2Mbps)	-
2402MHz	200
2440MHz	200
2480MHz	182

2.2 The Worst Case Measurement Configuration

The Worst Case Mode for Following Conformance Tests	
Tests Item	AC power-line conducted emissions
Condition	AC power-line conducted measurement for line and neutral Test Voltage: 120Vac / 60Hz
Operating Mode	CTX
1	Adapter Mode

The Worst Case Mode for Following Conformance Tests	
Tests Item	DTS Bandwidth Maximum Conducted Output Power Power Spectral Density Emissions in Non-restricted Frequency Bands
Test Condition	Conducted measurement at transmit chains

The Worst Case Mode for Following Conformance Tests			
Tests Item	Emissions in Restricted Frequency Bands		
Test Condition	Radiated measurement If EUT consist of multiple antenna assembly (multiple antenna are used in EUT regardless of spatial multiplexing MIMO configuration), the radiated test should be performed with highest antenna gain of each antenna type.		
Operating Mode < 1GHz	CTX		
1	Adapter Mode		
Operating Mode > 1GHz	CTX		
Orthogonal Planes of EUT	X Plane	Y Plane	Z Plane
			
Worst Planes of EUT	V		

The Worst Case Mode for Following Conformance Tests	
Tests Item	Simultaneous Transmission Analysis
Operating Mode	CTX
1	Radio 1_2.4G + Radio 2_5G + Radio 2_6E + Bluetooth
2	Radio 1_2.4G + Radio 2_5G + Radio 2_6E + Zigbee

Refer to Sporton Test Report No.: FA411229 for Co-location RF Exposure Evaluation and Appendix G for Radiated Emission Co-location.



2.3 Accessories

Accessories				
BRACKET,METAL CLIP CEILING,RVAQ-AP43	Brand Name	WNC	Model Name	6B.SRVAQ.00N
BRACKET,CEILING RAIL 1	Brand Name	WNC	Model Name	3S.005AL.111
BRACKET,CEILING RAIL 2	Brand Name	WNC	Model Name	3S.005AK.111

Reminder: Regarding to more detail and other information, please refer to user manual.

2.4 Support Equipment

Support Equipment – AC Conduction					
No.	Equipment	Brand Name	Model Name	FCC ID	Remark
1	AC Adapter	ASIAN POWER DEVICES INC.	WA-48A12R	-	Provided by Customer

Support Equipment – Conducted					
No.	Equipment	Brand Name	Model Name	FCC ID	Remark
1	Notebook	DELL	E5410	-	-
2	Adapter for NB	DELL	HA65NM130	-	-
3	AC Adapter	ASIAN POWER DEVICES INC.	WA-48A12R	-	Provided by Customer

Support Equipment – Radiated					
No.	Equipment	Brand Name	Model Name	FCC ID	Remark
1	AC Adapter	ASIAN POWER DEVICES INC.	WA-48A12R	-	Provided by Customer
2	RJ45 Cable	Power sync	CAT-6E-10	-	-
3	Notebook	Dell	P28S	-	Remote
4	AC Adapter (for NB)	HP	HSTNN-CA40	-	Remote
5	AC Power cable	PowerSync	TPCMRN0018	-	Remote

2.5 Test Setup Diagram

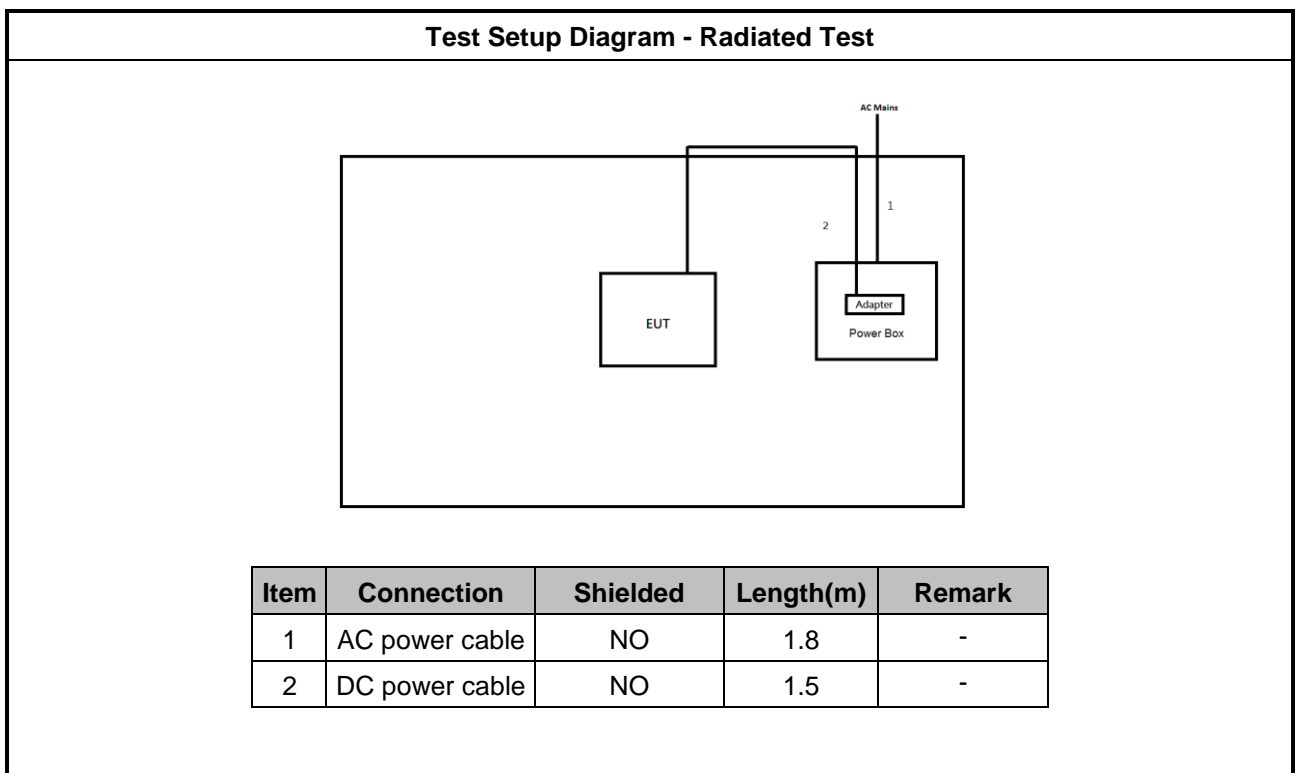
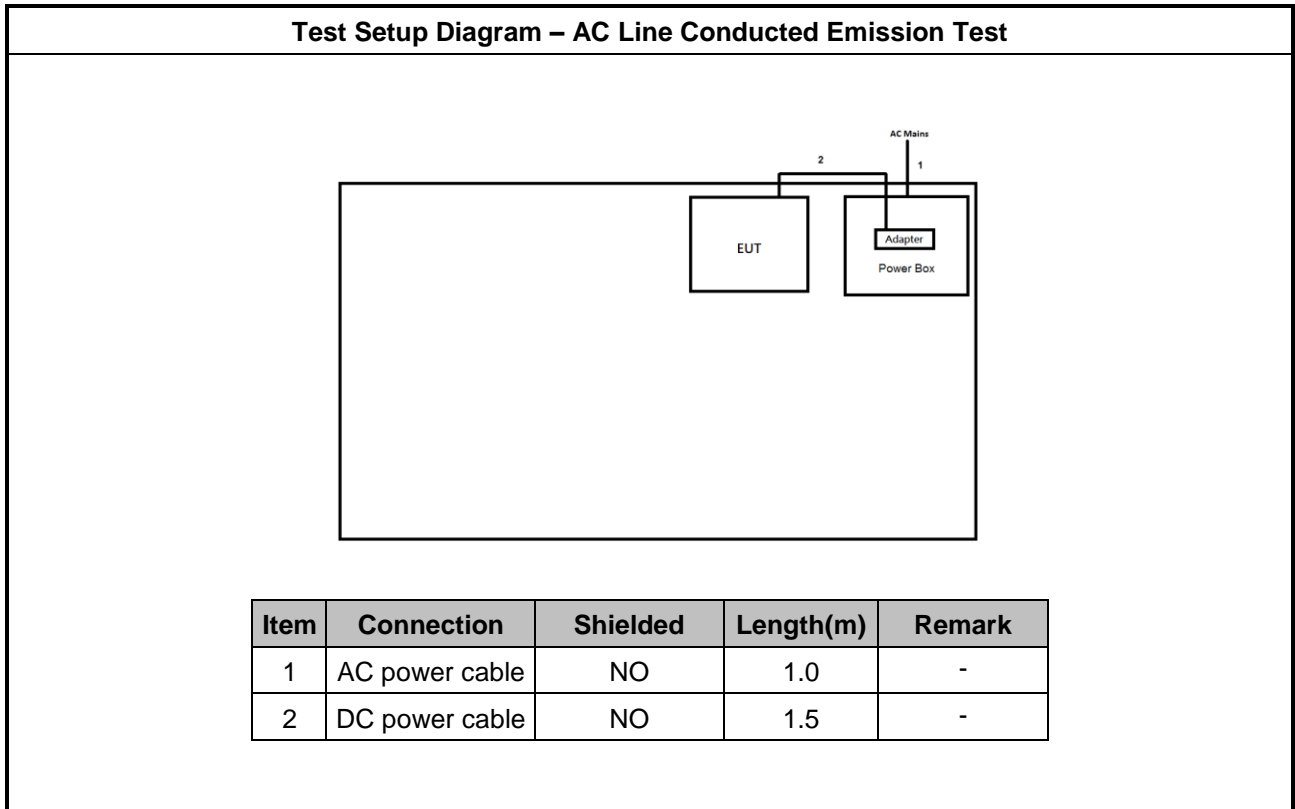



3 Transmitter Test Result

3.1 AC Power-line Conducted Emissions

3.1.1 AC Power-line Conducted Emissions Limit

AC Power-line Conducted Emissions Limit		
Frequency Emission (MHz)	Quasi-Peak	Average
0.15-0.5	66 - 56 *	56 - 46 *
0.5-5	56	46
5-30	60	50

Note 1: * Decreases with the logarithm of the frequency.

3.1.2 Measuring Instruments

Refer a test equipment and calibration data table in this test report.

3.1.3 Test Procedures

Test Method
<ul style="list-style-type: none"> Refer as ANSI C63.10-2013, clause 6.2 foray power-line conducted emissions.

3.1.4 Measurement Results Calculation

The measured Level is calculated using:

Corrected Reading: Raw(Read Level) +LISN(LISN Factor) + CL(Cable Loss) + AT(Attenuator).

3.1.5 Test Setup

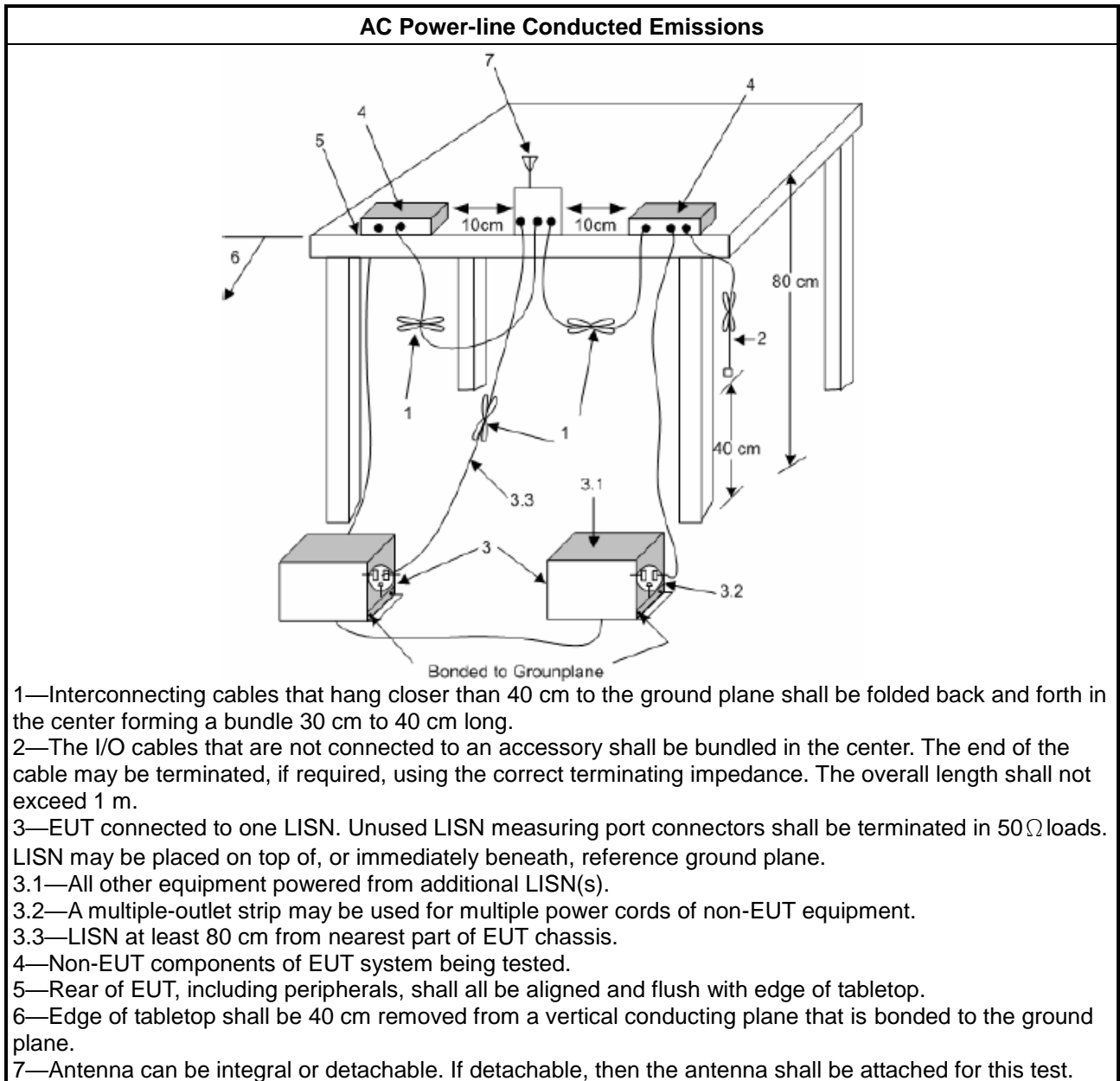

3.1.6 Test Result of AC Power-line Conducted Emissions

Refer as Appendix A

3.2 DTS Bandwidth

3.2.1 6dB Bandwidth Limit

6dB Bandwidth Limit	
Systems using digital modulation techniques:	
▪	6 dB bandwidth \geq 500 kHz.

3.2.2 Measuring Instruments

Refer a test equipment and calibration data table in this test report.

3.2.3 Test Procedures

Test Method	
▪	For the emission bandwidth shall be measured using one of the options below:
<input checked="" type="checkbox"/>	Refer as KDB 558074, clause 8.2 (11.8 of ANSI C63.10) DTS bandwidth measurement.
<input type="checkbox"/>	Refer as RSS-Gen, clause 6.7 for occupied bandwidth testing.
<input type="checkbox"/>	Refer as ANSI C63.10, clause 6.9.3 for occupied bandwidth testing.

3.2.4 Test Setup

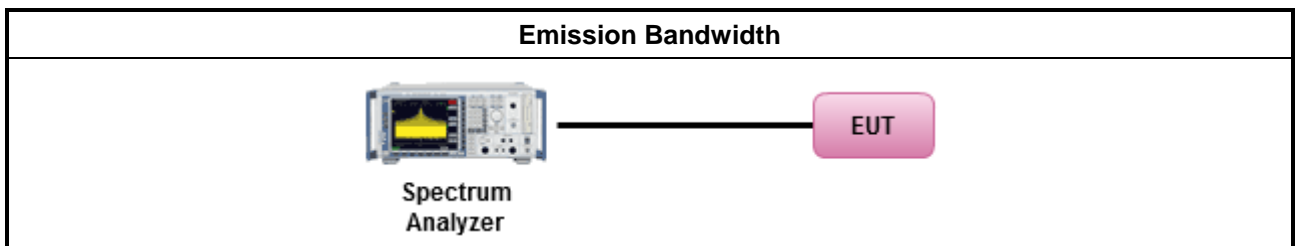

3.2.5 Test Result of Emission Bandwidth

Refer as Appendix B

3.3 Maximum Conducted Output Power

3.3.1 Maximum Conducted Output Power Limit

Maximum Conducted Output Power Limit	
	<ul style="list-style-type: none"> ▪ If $G_{TX} \leq 6$ dBi, then $P_{Out} \leq 30$ dBm (1 W)
	<ul style="list-style-type: none"> ▪ Point-to-multipoint systems (P2M): If $G_{TX} > 6$ dBi, then $P_{Out} = 30 - (G_{TX} - 6)$ dBm
	<ul style="list-style-type: none"> ▪ Point-to-point systems (P2P): If $G_{TX} > 6$ dBi, then $P_{Out} = 30 - (G_{TX} - 6)/3$ dBm
	<ul style="list-style-type: none"> ▪ Smart antenna system (SAS):
	<ul style="list-style-type: none"> - Single beam: If $G_{TX} > 6$ dBi, then $P_{Out} = 30 - (G_{TX} - 6)/3$ dBm
	<ul style="list-style-type: none"> - Overlap beam: If $G_{TX} > 6$ dBi, then $P_{Out} = 30 - (G_{TX} - 6)/3$ dBm
	<ul style="list-style-type: none"> - Aggregate power on all beams: If $G_{TX} > 6$ dBi, then $P_{Out} = 30 - (G_{TX} - 6)/3 + 8$ dB dBm
e.i.r.p. Power Limit:	
	<ul style="list-style-type: none"> ▪ 2400-2483.5 MHz Band
	<ul style="list-style-type: none"> ▪ Point-to-multipoint systems (P2M): $P_{eirp} \leq 36$ dBm (4 W)
	<ul style="list-style-type: none"> ▪ Point-to-point systems (P2P): $P_{eirp} \leq \text{MAX}(36, [P_{Out} + G_{TX}])$ dBm
	<ul style="list-style-type: none"> ▪ Smart antenna system (SAS)
	<ul style="list-style-type: none"> - Single beam: $P_{eirp} \leq \text{MAX}(36, P_{Out} + G_{TX})$ dBm
	<ul style="list-style-type: none"> - Overlap beam: $P_{eirp} \leq \text{MAX}(36, P_{Out} + G_{TX})$ dBm
	<ul style="list-style-type: none"> - Aggregate power on all beams: $P_{eirp} \leq \text{MAX}(36, [P_{Out} + G_{TX} + 8])$ dBm
<p>P_{Out} = maximum peak conducted output power or maximum conducted output power in dBm, G_{TX} = the maximum transmitting antenna directional gain in dBi.</p>	

3.3.2 Measuring Instruments

Refer a test equipment and calibration data table in this test report.

3.3.3 Test Procedures

Test Method	
<ul style="list-style-type: none"> ▪ Maximum Peak Conducted Output Power 	
<input type="checkbox"/>	Refer as KDB 558074, clause 8.3.1.1 (11.9.1.1 of ANSI C63.10) RBW ≥ EBW method.
<input type="checkbox"/>	Refer as KDB 558074, clause 8.3.1.2 (11.9.1.2 of ANSI C63.10) integrated band power method.
<input type="checkbox"/>	Refer as KDB 558074, clause 8.3.1.3 (11.9.1.3 of ANSI C63.10) peak power meter.
<ul style="list-style-type: none"> ▪ Maximum Average Conducted Output Power 	
<input type="checkbox"/>	Refer as KDB 558074, clause 8.3.2.2 (11.9.2.2 of ANSI C63.10) using a spectrum analyzer.
<input checked="" type="checkbox"/>	Refer as KDB 558074, clause 8.3.2.3 (11.9.2.3 of ANSI C63.10) using a power meter.
<ul style="list-style-type: none"> ▪ For conducted measurement. 	
<ul style="list-style-type: none"> ▪ If the EUT supports multiple transmit chains using options given below: Refer as KDB 662911, In-band power measurements. Using the measure-and-sum approach, measured all transmit ports individually. Sum the power (in linear power units e.g., mW) of all ports for each individual sample and save them. 	
<ul style="list-style-type: none"> ▪ If multiple transmit chains, EIRP calculation could be following as methods: $P_{total} = P_1 + P_2 + \dots + P_n$ (calculated in linear unit [mW] and transfer to log unit [dBm]) $EIRP_{total} = P_{total} + DG$ 	

3.3.4 Test Setup

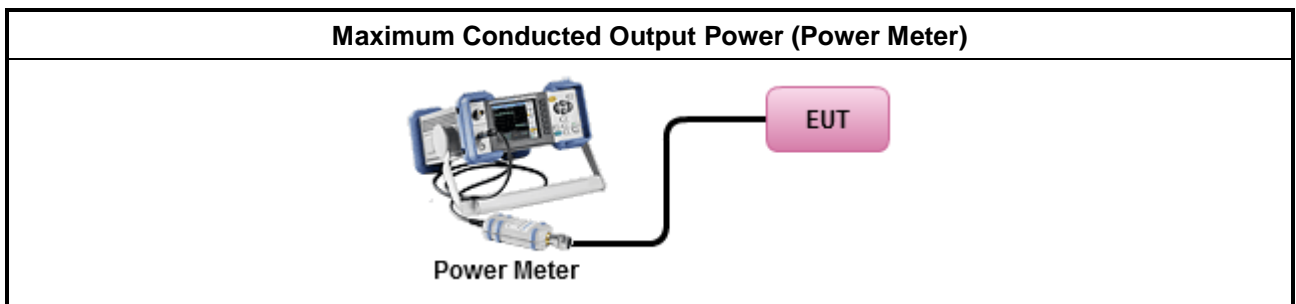

3.3.5 Test Result of Maximum Conducted Output Power

Refer as Appendix C

3.4 Power Spectral Density

3.4.1 Power Spectral Density Limit

Power Spectral Density Limit
<ul style="list-style-type: none"> Power Spectral Density (PSD) ≤ 8 dBm/3kHz

3.4.2 Measuring Instruments

Refer a test equipment and calibration data table in this test report.

3.4.3 Test Procedures

Test Method
<ul style="list-style-type: none"> Peak power spectral density procedures that the same method as used to determine the conducted output power. If maximum peak conducted output power was measured to demonstrate compliance to the output power limit, then the peak PSD procedure below (Method PKPSD) shall be used. If maximum conducted output power was measured to demonstrate compliance to the output power limit, then one of the average PSD procedures shall be used, as applicable based on the following criteria (the peak PSD procedure is also an acceptable option).
<input checked="" type="checkbox"/> Refer as KDB 558074, clause 8.4 (11.10 of ANSI C63.10) Max. PSD.
<ul style="list-style-type: none"> For conducted measurement. <ul style="list-style-type: none"> If The EUT supports multiple transmit chains using options given below: <ul style="list-style-type: none"> Measure and sum the spectra across the outputs. Refer as KDB 662911, In-band power spectral density (PSD). Sample all transmit ports simultaneously using a spectrum analyzer for each transmit port. Where the trace bin-by-bin of each transmit port summing can be performed. (i.e., in the first spectral bin of output 1 is summed with that in the first spectral bin of output 2 and that from the first spectral bin of output 3, and so on up to the NTX output to obtain the value for the first frequency bin of the summed spectrum.). Add up the amplitude (power) values for the different transmit chains and use this as the new data trace.

3.4.4 Test Setup

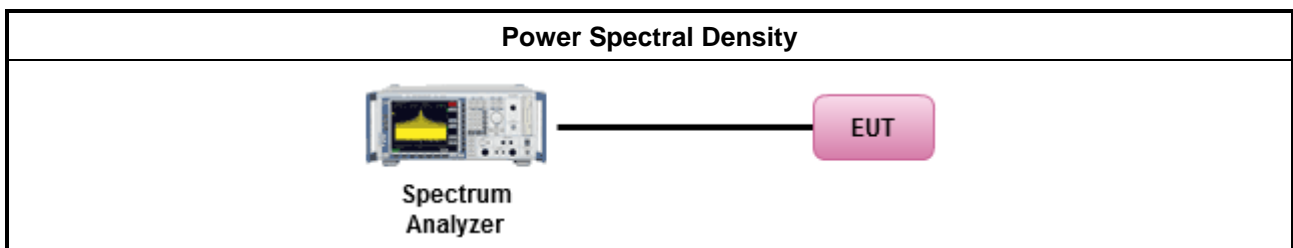

3.4.5 Test Result of Power Spectral Density

Refer as Appendix D

3.5 Emissions in Non-restricted Frequency Bands

3.5.1 Emissions in Non-restricted Frequency Bands Limit

Un-restricted Band Emissions Limit	
RF output power procedure	Limit (dB)
Peak output power procedure	20
Average output power procedure	30

Note 1: If the peak output power procedure is used to measure the fundamental emission power to demonstrate compliance to requirements, then the peak conducted output power measured within any 100 kHz outside the authorized frequency band shall be attenuated by at least 20 dB relative to the maximum measured in-band peak level.

Note 2: If the average output power procedure is used to measure the fundamental emission power to demonstrate compliance to requirements, then the power in any 100 kHz outside of the authorized frequency band shall be attenuated by at least 30 dB relative to the maximum measured in-band average level.

3.5.2 Measuring Instruments

Refer a test equipment and calibration data table in this test report.

3.5.3 Test Procedures

Test Method
<ul style="list-style-type: none"> Refer as KDB 558074, clause 8.5 (11.11 of ANSI C63.10) for non-restricted frequency bands.

3.5.4 Test Setup

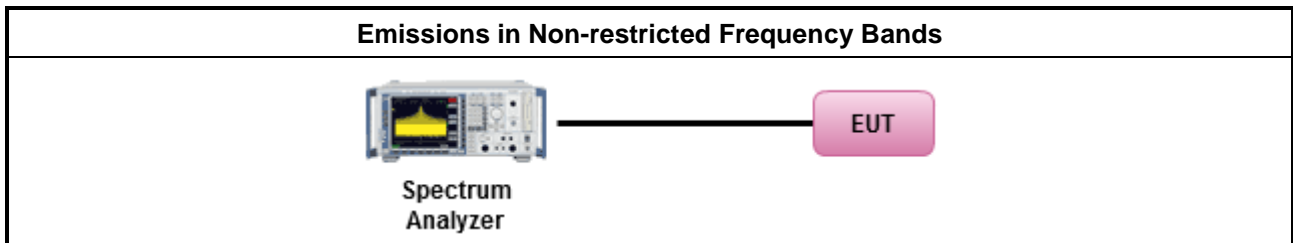

3.5.5 Test Result of Emissions in Non-restricted Frequency Bands

Refer as Appendix E



3.6 Emissions in Restricted Frequency Bands

3.6.1 Emissions in Restricted Frequency Bands Limit

Restricted Band Emissions Limit			
Frequency Range (MHz)	Field Strength (uV/m)	Field Strength (dBuV/m)	Measure Distance (m)
0.009~0.490	2400/F(kHz)	48.5 - 13.8	300
0.490~1.705	24000/F(kHz)	33.8 - 23	30
1.705~30.0	30	29	30
30~88	100	40	3
88~216	150	43.5	3
216~960	200	46	3
Above 960	500	54	3

Note 1: Test distance for frequencies at or above 30 MHz, measurements may be performed at a distance other than the limit distance provided they are not performed in the near field and the emissions to be measured can be detected by the measurement equipment. When performing measurements at a distance other than that specified, the results shall be extrapolated to the specified distance using an extrapolation factor of 20 dB/decade (inverse of linear distance for field-strength measurements, inverse of linear distance-squared for power-density measurements).

Note 2: Test distance for frequencies at below 30 MHz, measurements may be performed at a distance closer than the EUT limit distance; however, an attempt should be made to avoid making measurements in the near field. When performing measurements below 30 MHz at a closer distance than the limit distance, the results shall be extrapolated to the specified distance by either making measurements at a minimum of two or more distances on at least one radial to determine the proper extrapolation factor or by using the square of an inverse linear distance extrapolation factor (40 dB / decade). The test report shall specify the extrapolation method used to determine compliance of the EUT.

Note 3: Using the distance of 1m during the test for above 18 GHz, and the test value to correct for the distance factor at 3m.

3.6.2 Measuring Instruments

Refer a test equipment and calibration data table in this test report.

3.6.3 Test Procedures

Test Method	
	<ul style="list-style-type: none"> ▪ The average emission levels shall be measured in [duty cycle ≥ 98 or duty factor].
	<ul style="list-style-type: none"> ▪ Refer as ANSI C63.10, clause 6.10.3 band-edge testing shall be performed at the lowest frequency channel and highest frequency channel within the allowed operating band.
	<ul style="list-style-type: none"> ▪ For the transmitter unwanted emissions shall be measured using following options below:
	<ul style="list-style-type: none"> ▪ Refer as KDB 558074, clause 8.6 (11.12 of ANSI C63.10) for restricted frequency bands.
	<ul style="list-style-type: none"> ▪ For the transmitter band-edge emissions shall be measured using following options below:
	<ul style="list-style-type: none"> ▪ Refer as KDB 558074 clause 8.7.1, When the performing peak or average radiated measurements, emissions within 2 MHz of the authorized band edge may be measured using the marker-delta method described below.
	<ul style="list-style-type: none"> ▪ Refer as KDB 558074, clause 8.7.2 (6.10.6 of ANSI C63.10) for marker-delta method for band-edge measurements.
	<ul style="list-style-type: none"> ▪ Refer as KDB 558074, clause 8.7.3 for narrower resolution bandwidth (100kHz) using the band power and summing the spectral levels.
	<ul style="list-style-type: none"> ▪ Use the following spectrum analyzer settings:
	<ul style="list-style-type: none"> ▪ Set RBW=100 kHz for f < 1 GHz; VBW=3 * RBW; Sweep = auto; Detector function = peak; Trace = max hold.
	<ul style="list-style-type: none"> ▪ Set RBW = 1 MHz, VBW= 3MHz for f ≥ 1 GHz for peak measurement. For average measurement, refer as 1.1.4.
	<ul style="list-style-type: none"> ▪ KDB 414788 Open-Field Test Sites and Chamber Correlation Justification.
	<ul style="list-style-type: none"> ▪ Based on FCC 15.31(f)(2): measurements may be performed at a distance closer than that specified in regulations; however, an attempt should be made to avoid making measurements in the near field.
	<ul style="list-style-type: none"> ▪ Open-field site and chamber correlation testing had been performed and chamber measured test result is the worst case test result.

3.6.4 Measurement Results Calculation

The measured Level is calculated using:

Corrected Reading: Raw(Read Level) + AF(Antenna Factor) + CL(Cable Loss) - PA(Preamp Factor)

3.6.5 Test Setup

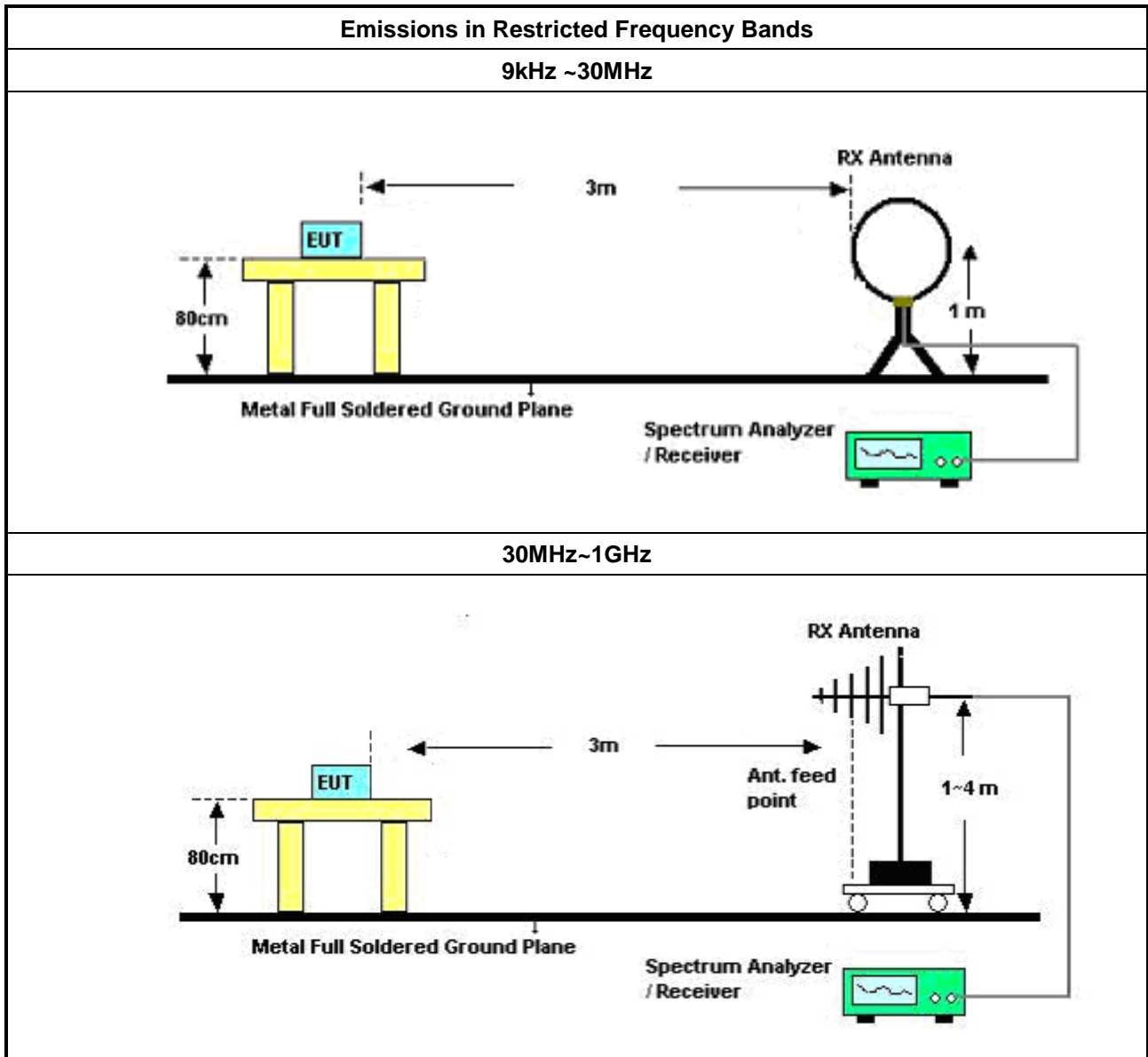

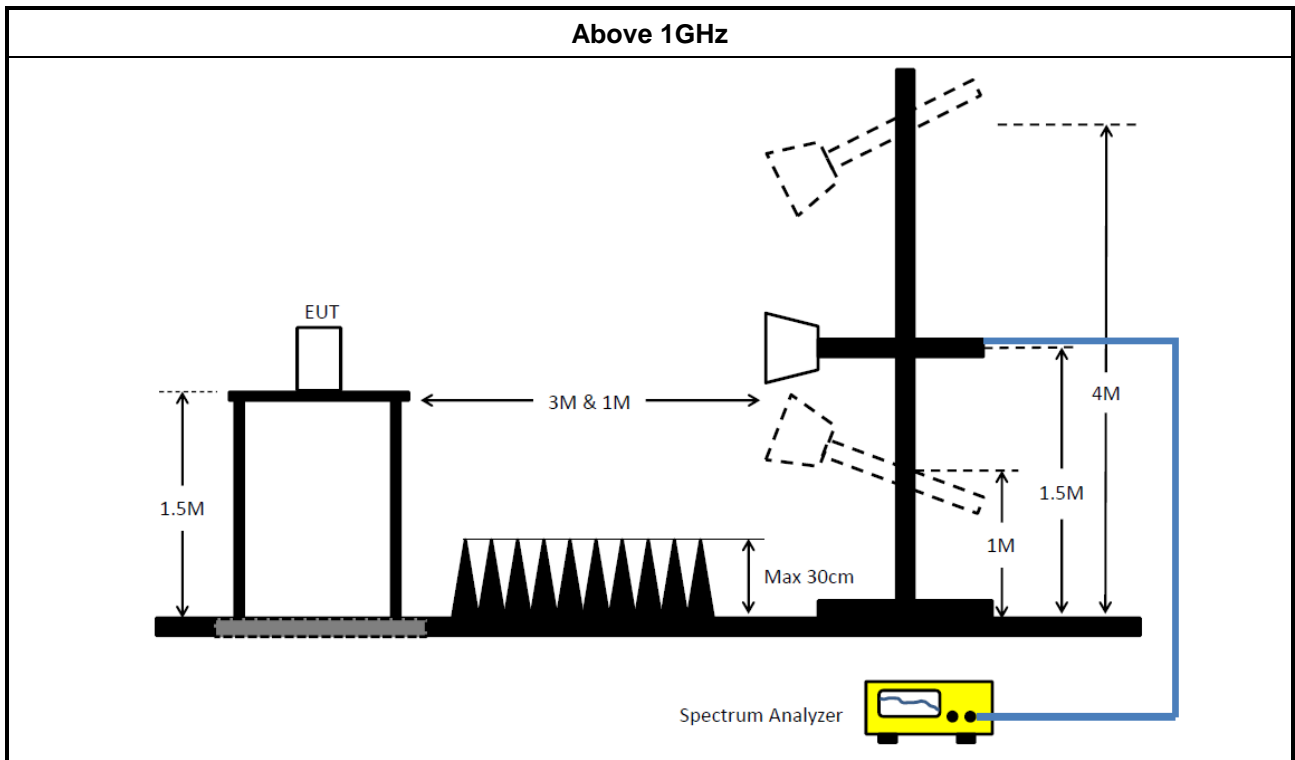

3.6.6 Test Result of Emissions in Restricted Frequency Bands (Below 30MHz)

The amplitude of spurious emissions which are attenuated by more than 20dB below the permissible value has no need to be reported.

3.6.7 Test Result of Emissions in Restricted Frequency Bands

Refer as Appendix F



4 Test Equipment and Calibration Data

Instrument for AC Conduction

Instrument	Manufacturer /Brand	Model No.	Serial No.	Spec.	Calibration Date	Calibration Due Date
EMI Test Receiver	ROHDE & SCHWARZ	ESR	102318	9kHz ~ 3.6GHz	27/Dec/2023	26/Dec/2024
LISN(Artificial Mains Network)	SCHWARZBECK	NSLK 8127	8127477	9kHz ~ 30MHz	12/Apr/2024	11/Apr/2025
Two-Line V-Network	R&S	ENV 216	101274	9kHz ~ 30MHz	18/Jun/2024	17/Jun/2025
RF Cable 5m	TITAN	TITAN	CO04-cable-01	9 kHz~200MHz	27/Feb/2024	26/Feb/2025
Impuls Begrenzer Pulse Limiter	SCHWARZBECK	VTSD 9561-F	9561-F041	9kHz ~ 30MHz	18/Oct/2023	17/Oct/2024
Software	Sporton	SENSE-EMI	V5.11.3	-	NCR	NCR

NCR: No Calibration Required

Instrument for Conducted Test

Instrument	Manufacturer /Brand	Model No.	Serial No.	Spec.	Calibration Date	Calibration Due Date
Signal Analyzer	R&S	FSV 40	101515	9kHz~40GHz	02/Feb/2024	01/Feb/2025
SMB100A Signal Generator	R&S	SMB100A	181147	100kHz~40GHz	20/Oct/2023	19/Oct/2024
Power Meter	Anritsu	ML2495A	1517010	300MHz~40GHz	15/Dec/2023	14/Dec/2024
Pulse Sensor	Anritsu	MA2411B	1339407	300MHz~40GHz	15/Dec/2023	14/Dec/2024
SENSE-15247_FS	Sporton	V5.11.18	N/A	N/A	N/A	N/A



Instrument for Radiated Test

Table with 7 columns: Instrument, Manufacturer /Brand, Model No., Serial No., Spec., Calibration Date, Calibration Due Date. Rows include 3m Semi Anechoic Chamber, EMI Test Receiver, Signal Analyzer, Loop Antenna, Bilog Antenna & 6dB Attenuator, Double Ridged Guide Horn Antenna, Broadband Horn Antenna, RF Cable, Pre-Amplifier, Amplifier, and SENSE-15247-FS.

Instrument for Radiated Test (Co-location)

Table with 7 columns: Instrument, Manufacturer /Brand, Model No., Serial No., Spec., Calibration Date, Calibration Due Date. Rows include 3m Semi Anechoic Chamber, Signal Analyzer, Double Ridged Guide Horn Antenna, Broadband Horn Antenna, RF Cable, Preamplifier, Amplifier, and SENSE-EMI.



Summary

Mode	Result	Type	Freq (Hz)	Level (dBuV)	Limit (dBuV)	Margin (dB)	Condition
Mode 1	Pass	QP	152.414k	43.42	65.87	-22.45	Line



Result

Mode	Result	Type	Freq (Hz)	Level (dBuV)	Limit (dBuV)	Margin (dB)	Condition	Comments
Mode 1	Pass	QP	152.414k	43.42	65.87	-22.45	Line	-
Mode 1	Pass	AV	152.414k	28.91	55.87	-26.96	Line	-
Mode 1	Pass	QP	218.303k	34.20	62.88	-28.68	Line	-
Mode 1	Pass	AV	218.303k	22.52	52.88	-30.36	Line	-
Mode 1	Pass	QP	307.723k	24.15	60.03	-35.88	Line	-
Mode 1	Pass	AV	307.723k	17.36	50.03	-32.67	Line	-
Mode 1	Pass	QP	656.999k	25.86	56.00	-30.14	Line	-
Mode 1	Pass	AV	656.999k	22.21	46.00	-23.79	Line	-
Mode 1	Pass	QP	2.533M	23.01	56.00	-32.99	Line	-
Mode 1	Pass	AV	2.533M	19.81	46.00	-26.19	Line	-
Mode 1	Pass	QP	5.672M	18.27	60.00	-41.73	Line	-
Mode 1	Pass	AV	5.672M	16.29	50.00	-33.71	Line	-
Mode 1	Pass	QP	168.439k	37.89	65.04	-27.15	Neutral	-
Mode 1	Pass	AV	168.439k	27.14	55.04	-27.90	Neutral	-
Mode 1	Pass	QP	219.933k	35.89	62.83	-26.94	Neutral	-
Mode 1	Pass	AV	219.933k	21.38	52.83	-31.45	Neutral	-
Mode 1	Pass	QP	249.042k	31.30	61.79	-30.49	Neutral	-
Mode 1	Pass	AV	249.042k	20.41	51.79	-31.38	Neutral	-
Mode 1	Pass	QP	670.245k	25.05	56.00	-30.95	Neutral	-
Mode 1	Pass	AV	670.245k	19.49	46.00	-26.51	Neutral	-
Mode 1	Pass	QP	2.492M	22.29	56.00	-33.71	Neutral	-
Mode 1	Pass	AV	2.492M	19.73	46.00	-26.27	Neutral	-
Mode 1	Pass	QP	14.494M	21.84	60.00	-38.16	Neutral	-
Mode 1	Pass	AV	14.494M	19.65	50.00	-30.35	Neutral	-

Conducted Emissions at Powerline_Mode 1

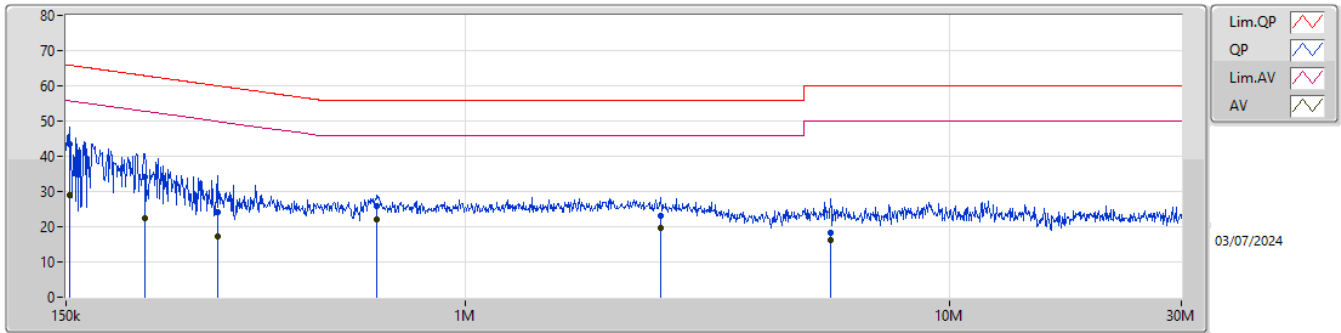

Type	Freq (Hz)	Level (dBuV)	Limit (dBuV)	Margin (dB)	Factor (dB)	Condition	Comment	Raw (dBuV)	LISN (dB)	CL (dB)	AT (dB)
QP	152.414k	43.42	65.87	-22.45	19.48	Line	-	23.94	9.66	0.07	9.75
AV	152.414k	28.91	55.87	-26.96	19.48	Line	-	9.43	9.66	0.07	9.75
QP	218.303k	34.20	62.88	-28.68	19.43	Line	-	14.77	9.65	0.09	9.69
AV	218.303k	22.52	52.88	-30.36	19.43	Line	-	3.09	9.65	0.09	9.69
QP	307.723k	24.15	60.03	-35.88	19.49	Line	-	4.66	9.65	0.11	9.73
AV	307.723k	17.36	50.03	-32.67	19.49	Line	-	-2.13	9.65	0.11	9.73
QP	656.999k	25.86	56.00	-30.14	19.54	Line	-	6.32	9.66	0.10	9.78
AV	656.999k	22.21	46.00	-23.79	19.54	Line	-	2.67	9.66	0.10	9.78
QP	2.533M	23.01	56.00	-32.99	19.58	Line	-	3.43	9.68	0.10	9.80
AV	2.533M	19.81	46.00	-26.19	19.58	Line	-	0.23	9.68	0.10	9.80
QP	5.672M	18.27	60.00	-41.73	19.55	Line	-	-1.28	9.70	0.06	9.79
AV	5.672M	16.29	50.00	-33.71	19.55	Line	-	-3.26	9.70	0.06	9.79

Conducted Emissions at Powerline_Mode 1

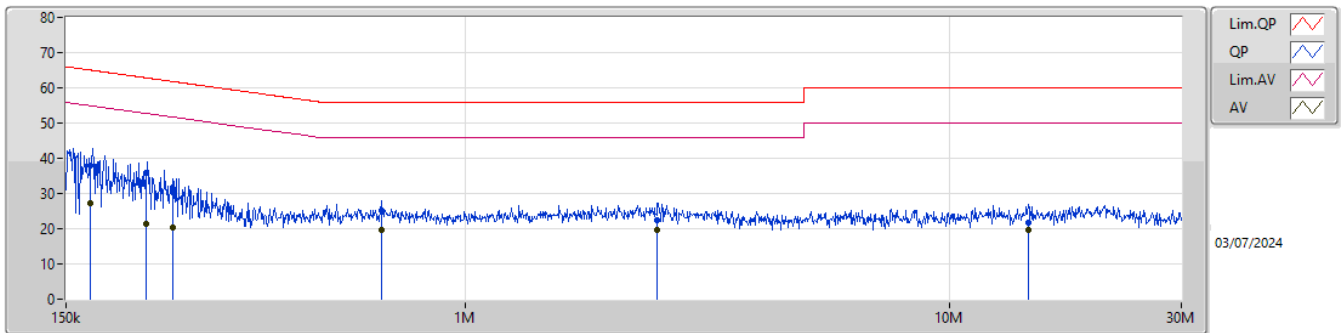

Type	Freq (Hz)	Level (dBuV)	Limit (dBuV)	Margin (dB)	Factor (dB)	Condition	Comment	Raw (dBuV)	LISN (dB)	CL (dB)	AT (dB)
QP	168.439k	37.89	65.04	-27.15	19.41	Neutral	-	18.48	9.60	0.08	9.73
AV	168.439k	27.14	55.04	-27.90	19.41	Neutral	-	7.73	9.60	0.08	9.73
QP	219.933k	35.89	62.83	-26.94	19.38	Neutral	-	16.51	9.60	0.09	9.69
AV	219.933k	21.38	52.83	-31.45	19.38	Neutral	-	2.00	9.60	0.09	9.69
QP	249.042k	31.30	61.79	-30.49	19.41	Neutral	-	11.89	9.60	0.10	9.71
AV	249.042k	20.41	51.79	-31.38	19.41	Neutral	-	1.00	9.60	0.10	9.71
QP	670.245k	25.05	56.00	-30.95	19.49	Neutral	-	5.56	9.61	0.10	9.78
AV	670.245k	19.49	46.00	-26.51	19.49	Neutral	-	0.00	9.61	0.10	9.78
QP	2.492M	22.29	56.00	-33.71	19.51	Neutral	-	2.78	9.61	0.10	9.80
AV	2.492M	19.73	46.00	-26.27	19.51	Neutral	-	0.22	9.61	0.10	9.80
QP	14.494M	21.84	60.00	-38.16	19.59	Neutral	-	2.25	9.67	0.09	9.83
AV	14.494M	19.65	50.00	-30.35	19.59	Neutral	-	0.06	9.67	0.09	9.83



Summary

Mode	Max-N dB (Hz)	Max-OBW (Hz)	ITU-Code	Min-N dB (Hz)	Min-OBW (Hz)
2.4-2.4835GHz	-	-	-	-	-
BT-LE(1Mbps)	731.25k	1.048M	1M05F1D	727.5k	1.047M
BT-LE(2Mbps)	1.343M	2.113M	2M11F1D	1.34M	2.104M

Max-N dB = Maximum 6dB down bandwidth; Max-OBW = Maximum 99% occupied bandwidth;
Min-N dB = Minimum 6dB down bandwidth; Min-OBW = Minimum 99% occupied bandwidth



Result

Mode	Result	Limit (Hz)	Port 1-N dB (Hz)	Port 1-OBW (Hz)
BT-LE(1Mbps)	-	-	-	-
2402MHz	Pass	500k	731.25k	1.047M
2440MHz	Pass	500k	727.5k	1.048M
2480MHz	Pass	500k	730k	1.047M
BT-LE(2Mbps)	-	-	-	-
2402MHz	Pass	500k	1.343M	2.104M
2440MHz	Pass	500k	1.343M	2.109M
2480MHz	Pass	500k	1.34M	2.113M

Port X-N dB = Port X 6dB down bandwidth;
Port X-OBW = Port X 99% occupied bandwidth

2.4-2.4835GHz_BT-LE(1Mbps)

EBW-DTS

2402MHz

06/05/2024

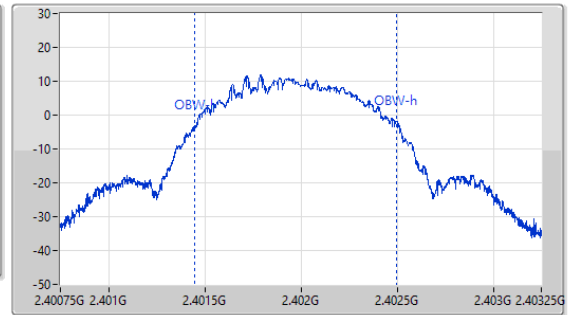
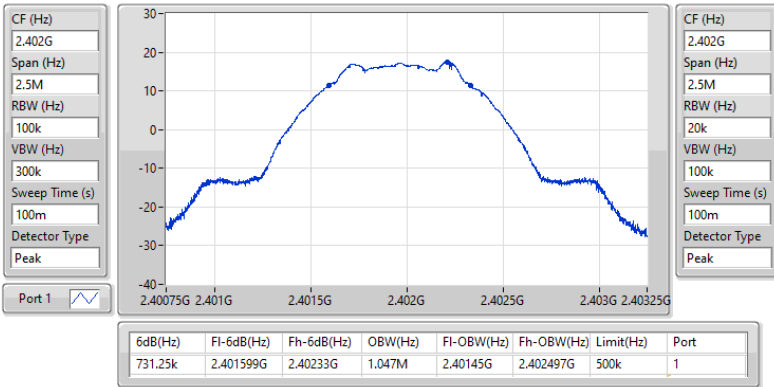

2.4-2.4835GHz_BT-LE(2Mbps)

EBW-DTS

2402MHz

06/05/2024

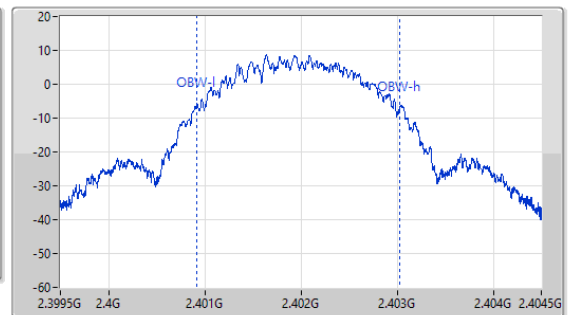
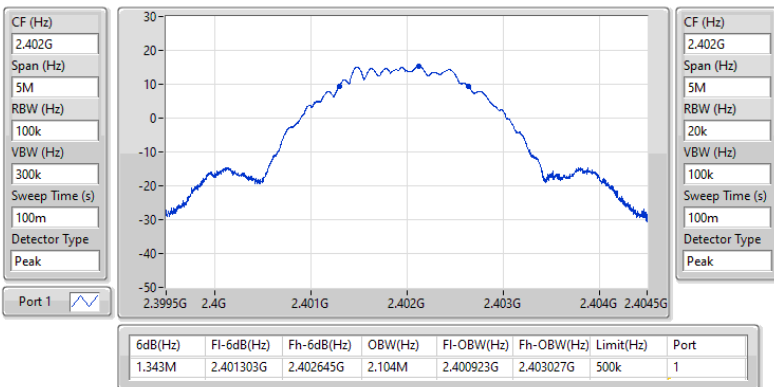



Summary

Mode	Total Power (dBm)	Total Power (W)
2.4-2.4835GHz	-	-
BT-LE(1Mbps)	18.27	0.06714
BT-LE(2Mbps)	18.30	0.06761



Result

Mode	Result	DG (dBi)	Total Power (dBm)	Power Limit (dBm)
BT-LE(1Mbps)	-	-	-	-
2402MHz	Pass	5.00	18.22	30.00
2440MHz	Pass	5.00	18.27	30.00
2480MHz	Pass	5.00	18.14	30.00
BT-LE(2Mbps)	-	-	-	-
2402MHz	Pass	5.00	18.30	30.00
2440MHz	Pass	5.00	18.27	30.00
2480MHz	Pass	5.00	16.54	30.00

DG = Directional Gain; Port X = Port X output power



Summary

Mode	PD (dBm/RBW)
2.4-2.4835GHz	-
BT-LE(1Mbps)	0.83
BT-LE(2Mbps)	0.81

RBW = 3kHz;



Result

Mode	Result	DG (dBi)	PD (dBm/RBW)	PD Limit (dBm/RBW)
BT-LE(1Mbps)	-	-	-	-
2402MHz	Pass	5.00	0.77	8.00
2440MHz	Pass	5.00	0.83	8.00
2480MHz	Pass	5.00	0.74	8.00
BT-LE(2Mbps)	-	-	-	-
2402MHz	Pass	5.00	0.81	8.00
2440MHz	Pass	5.00	0.78	8.00
2480MHz	Pass	5.00	-1.18	8.00

DG = Directional Gain; RBW = 3kHz;
PD = trace bin-by-bin of each transmits port summing can be performed maximum power density; Port X = Port X Power Density;

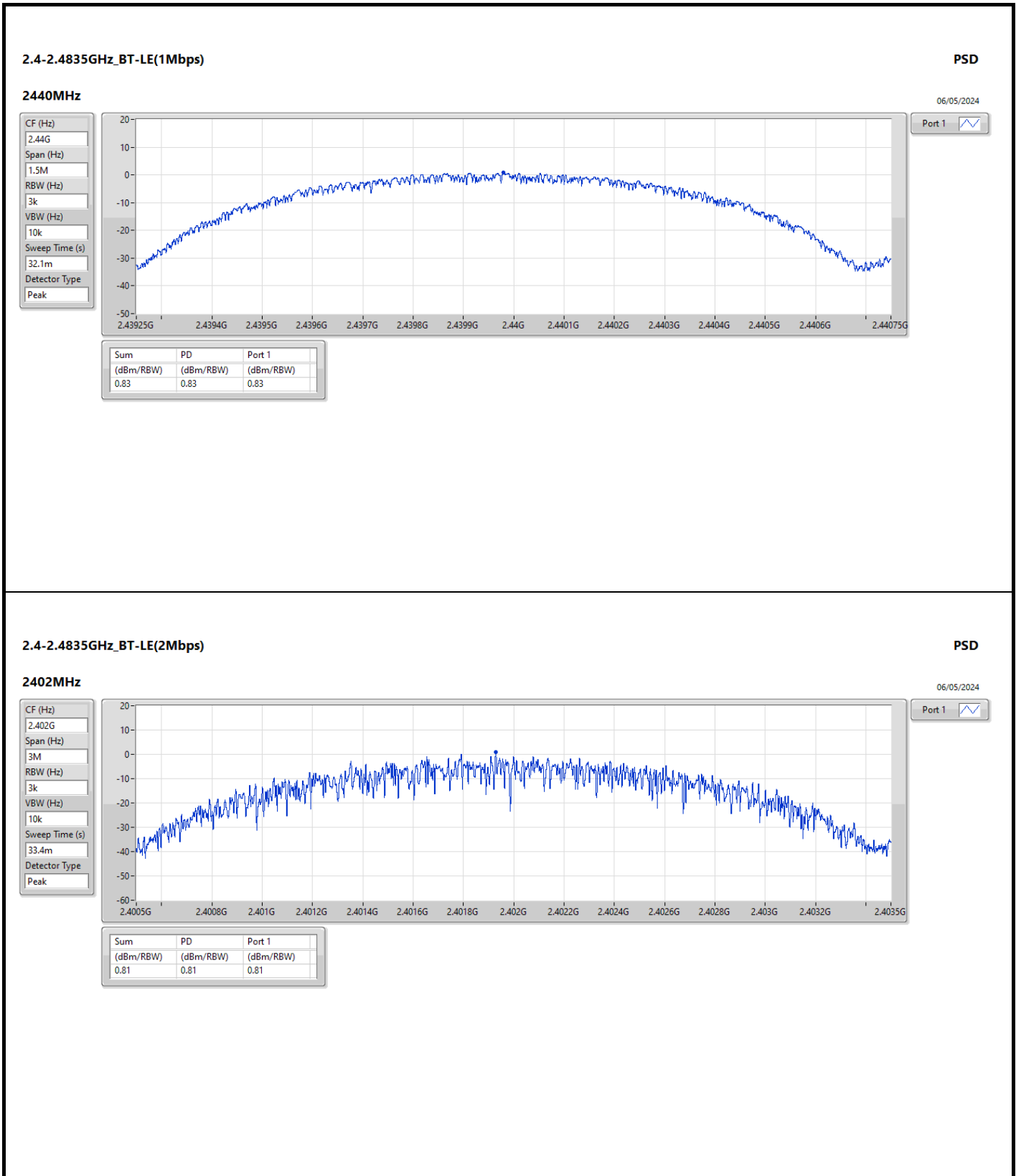



Summary

Mode	Result	Ref (Hz)	Ref (dBm)	Limit (dBm)	Freq (Hz)	Level (dBm)	Freq (Hz)	Level (dBm)	Freq (Hz)	Level (dBm)	Freq (Hz)	Level (dBm)	Freq (Hz)	Level (dBm)	Port
2.4-2.4835GHz	-	-	-	-	-	-	-	-	-	-	-	-	-	-	-
BT-LE(1Mbps)	Pass	2.44025G	17.96	-12.04	2.11328G	-58.88	2.39988G	-33.69	2.4G	-32.94	2.50266G	-57.38	25G	-26.39	1
BT-LE(2Mbps)	Pass	2.402G	12.10	-17.90	2.16145G	-58.54	2.4G	-19.04	2.4G	-17.94	2.50326G	-54.73	21.95172G	-30.56	1



Result

Mode	Result	Ref (Hz)	Ref (dBm)	Limit (dBm)	Freq (Hz)	Level (dBm)	Freq (Hz)	Level (dBm)	Freq (Hz)	Level (dBm)	Freq (Hz)	Level (dBm)	Freq (Hz)	Level (dBm)	Port
BT-LE(1Mbps)	-	-	-	-	-	-	-	-	-	-	-	-	-	-	-
2402MHz	Pass	2.44025G	17.96	-12.04	2.11328G	-58.88	2.39988G	-33.69	2.4G	-32.94	2.50266G	-57.38	25G	-26.39	1
2440MHz	Pass	2.44025G	17.96	-12.04	1.97345G	-59.02	2.39852G	-57.26	2.4G	-60.23	2.50114G	-57.39	23.42525G	-26.83	1
2480MHz	Pass	2.44025G	17.96	-12.04	2.03925G	-58.51	2.39936G	-58.26	2.4G	-59.50	2.50322G	-56.85	24.29698G	-27.92	1
BT-LE(2Mbps)	-	-	-	-	-	-	-	-	-	-	-	-	-	-	-
2402MHz	Pass	2.402G	12.10	-17.90	2.16145G	-58.54	2.4G	-19.04	2.4G	-17.94	2.50326G	-54.73	21.95172G	-30.56	1
2440MHz	Pass	2.402G	12.10	-17.90	2.16028G	-58.44	2.39132G	-55.38	2.4G	-61.13	2.50114G	-56.07	24.92407G	-28.87	1
2480MHz	Pass	2.402G	12.10	-17.90	1.80425G	-57.47	2.3996G	-55.89	2.4G	-60.80	2.50182G	-55.80	24.86221G	-30.43	1

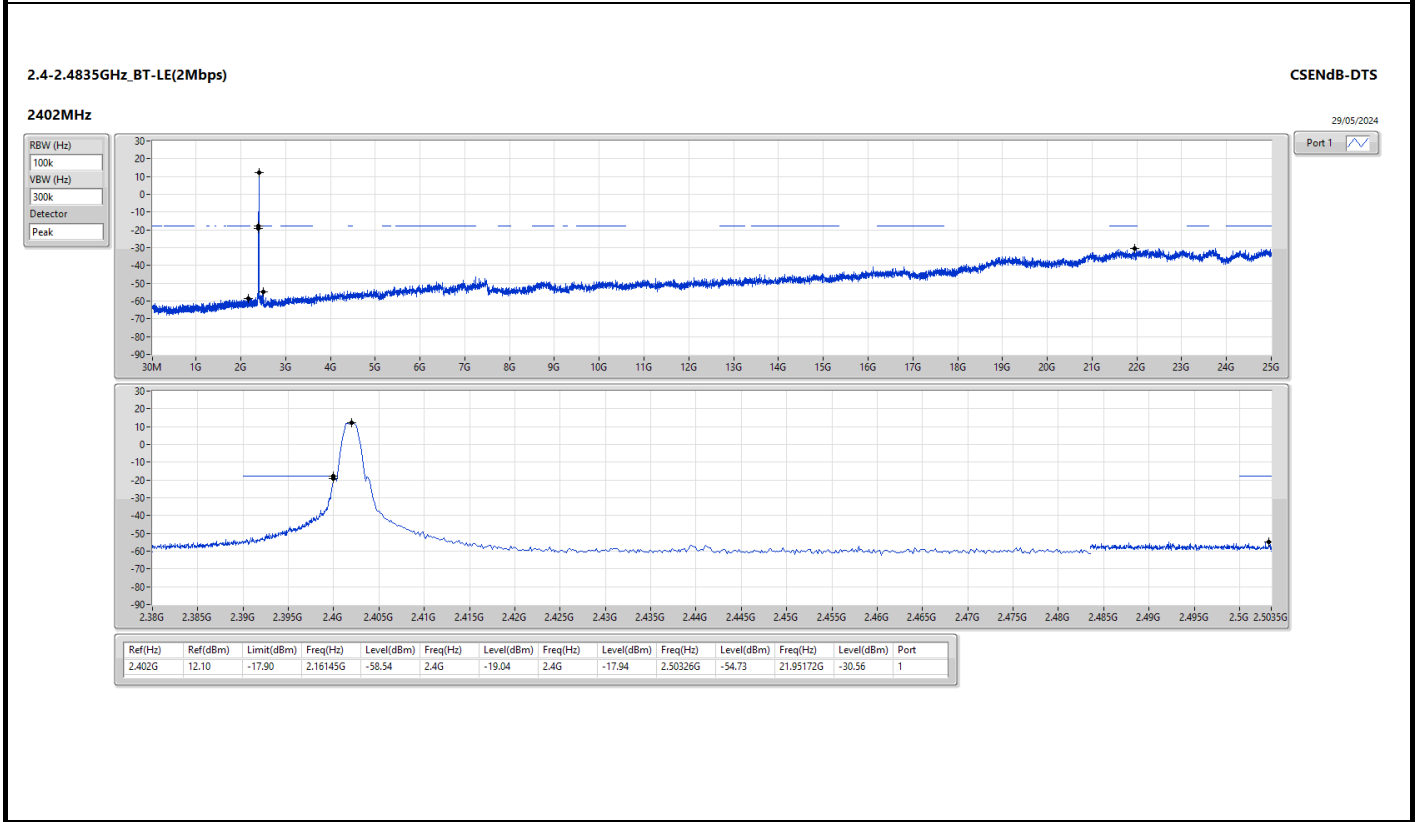
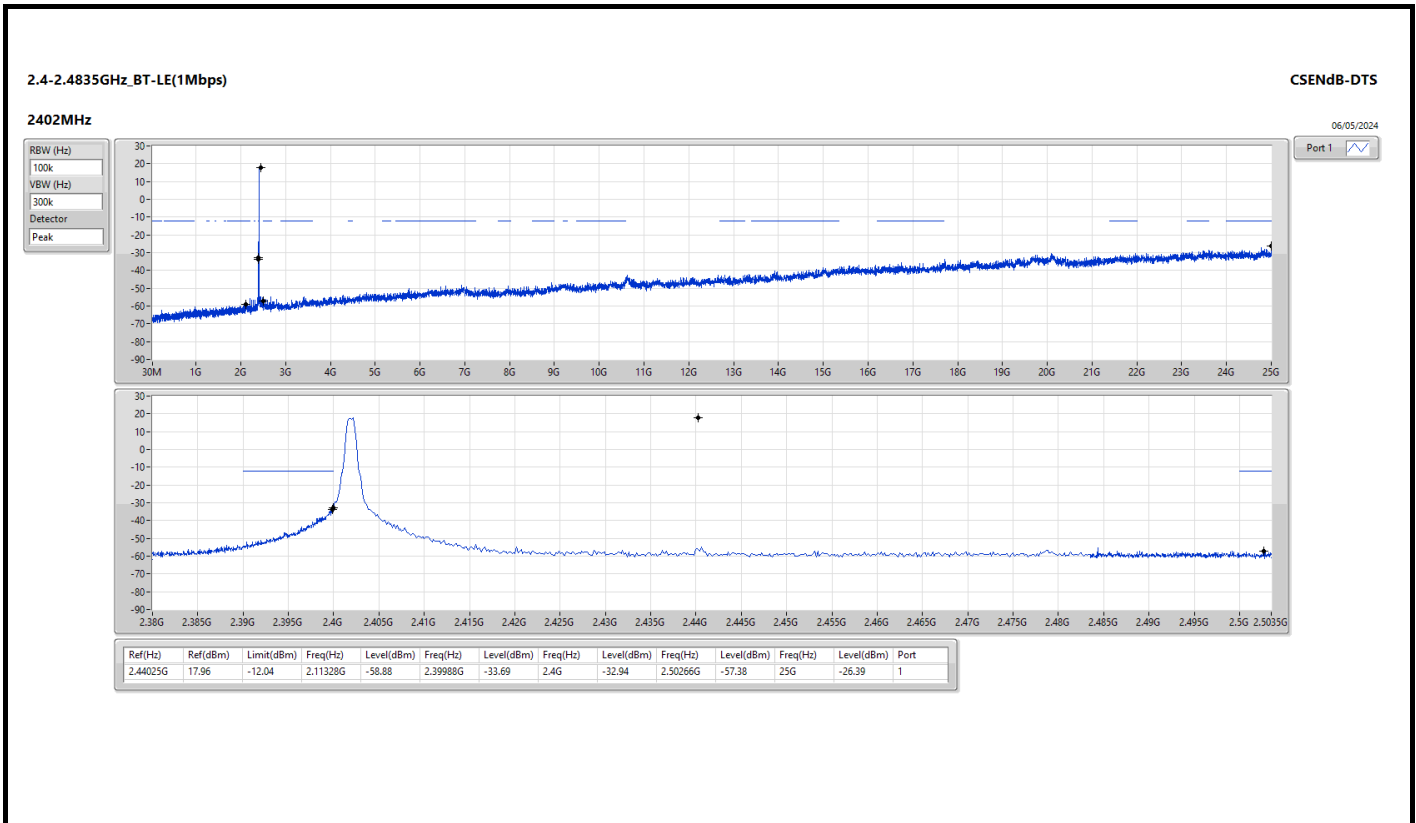



Summary

Mode	Result	Type	Freq (Hz)	Level (dBuV/m)	Limit (dBuV/m)	Margin (dB)	Dist (m)	Condition	Azimuth (°)	Height (m)
2.4-2.4835GHz	-	-	-	-	-	-	-	-	-	-
BT-LE(2Mbps)	Pass	PK	30M	33.72	40.00	-6.28	3	Vertical	0	1.00



Result

Mode	Result	Type	Freq (Hz)	Level (dBuV/m)	Limit (dBuV/m)	Margin (dB)	Dist (m)	Condition	Azimuth (°)	Height (m)
BT-LE(2Mbps)	-	-	-	-	-	-	-	-	-	-
2440MHz	Pass	PK	30M	33.72	40.00	-6.28	3	Vertical	0	1.00
2440MHz	Pass	PK	150.28M	28.11	43.50	-15.39	3	Vertical	0	1.00
2440MHz	Pass	PK	247.28M	26.14	46.00	-19.86	3	Vertical	0	1.00
2440MHz	Pass	PK	443.22M	26.53	46.00	-19.47	3	Vertical	0	1.00
2440MHz	Pass	PK	495.6M	26.40	46.00	-19.60	3	Vertical	0	1.00
2440MHz	Pass	PK	652.74M	26.84	46.00	-19.16	3	Vertical	0	1.00
2440MHz	Pass	PK	31.94M	25.59	40.00	-14.41	3	Horizontal	360	1.00
2440MHz	Pass	PK	117.3M	27.30	43.50	-16.20	3	Horizontal	360	1.00
2440MHz	Pass	PK	159.98M	29.95	43.50	-13.55	3	Horizontal	360	1.00
2440MHz	Pass	PK	243.4M	31.64	46.00	-14.36	3	Horizontal	360	1.00
2440MHz	Pass	PK	353.98M	29.52	46.00	-16.48	3	Horizontal	360	1.00
2440MHz	Pass	PK	441.28M	26.92	46.00	-19.08	3	Horizontal	360	1.00

2.4-2.4835GHz_BT-LE(2Mbps)

2440MHz_Adapter

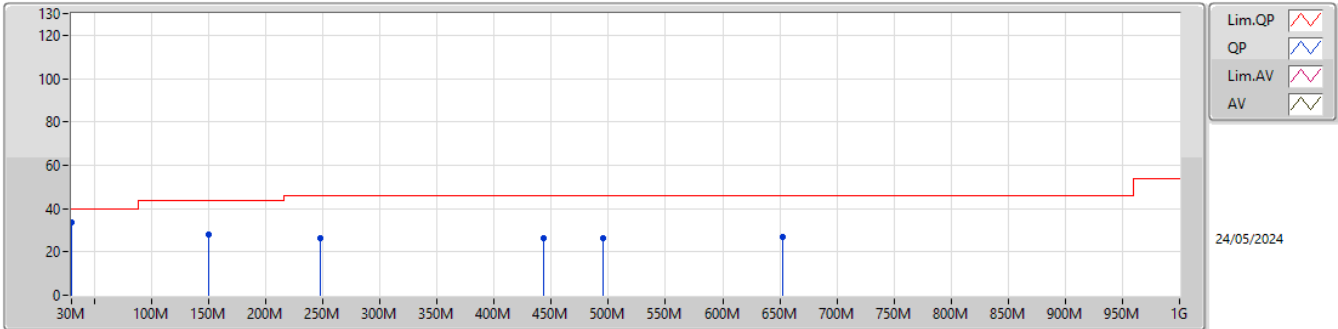

Type	Freq (Hz)	Level (dBuV/m)	Limit (dBuV/m)	Margin (dB)	Factor (dB)	Dist (m)	Condition	Azimuth (°)	Height (m)	Raw (dBuV)	AF (dB)	CL (dB)	PA (dB)
PK	30M	33.72	40.00	-6.28	-3.60	3	Vertical	0	1.00	37.32	23.36	0.42	27.38
PK	150.28M	28.11	43.50	-15.39	-10.58	3	Vertical	0	1.00	38.69	15.57	0.91	27.06
PK	247.28M	26.14	46.00	-19.86	-8.34	3	Vertical	0	1.00	34.48	17.16	1.15	26.65
PK	443.22M	26.53	46.00	-19.47	-4.57	3	Vertical	0	1.00	31.10	21.72	1.56	27.85
PK	495.6M	26.40	46.00	-19.60	-3.90	3	Vertical	0	1.00	30.30	22.50	1.64	28.04
PK	652.74M	26.84	46.00	-19.16	-2.43	3	Vertical	0	1.00	29.27	24.15	1.86	28.44

2.4-2.4835GHz_BT-LE(2Mbps)

2440MHz_Adapter

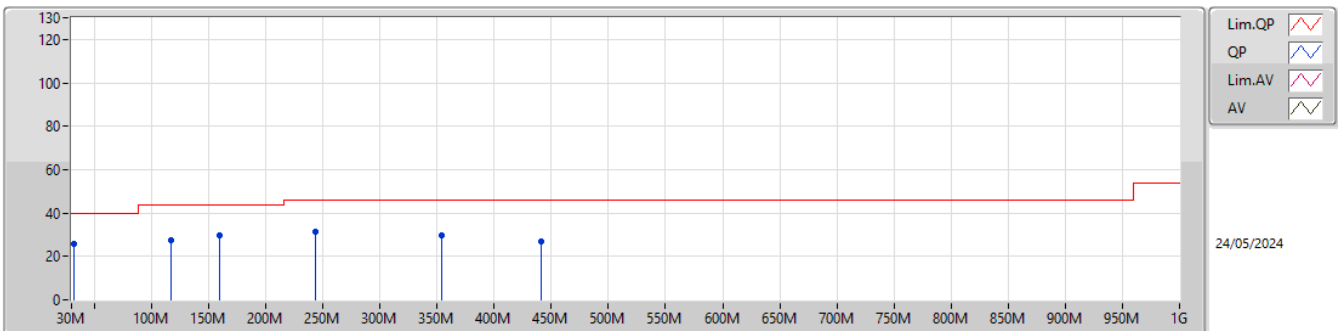

Type	Freq (Hz)	Level (dBuV/m)	Limit (dBuV/m)	Margin (dB)	Factor (dB)	Dist (m)	Condition	Azimuth (°)	Height (m)	Raw (dBuV)	AF (dB)	CL (dB)	PA (dB)
PK	31.94M	25.59	40.00	-14.41	-4.49	3	Horizontal	360	1.00	30.08	22.46	0.43	27.38
PK	117.3M	27.30	43.50	-16.20	-9.44	3	Horizontal	360	1.00	36.74	16.95	0.81	27.20
PK	159.98M	29.95	43.50	-13.55	-10.91	3	Horizontal	360	1.00	40.86	15.18	0.93	27.02
PK	243.4M	31.64	46.00	-14.36	-8.80	3	Horizontal	360	1.00	40.44	16.72	1.15	26.67
PK	353.98M	29.52	46.00	-16.48	-6.11	3	Horizontal	360	1.00	35.63	19.56	1.39	27.06
PK	441.28M	26.92	46.00	-19.08	-4.55	3	Horizontal	360	1.00	31.47	21.73	1.55	27.83



Summary

Mode	Result	Type	Freq (Hz)	Level (dBuV/m)	Limit (dBuV/m)	Margin (dB)	Dist (m)	Condition	Azimuth (°)	Height (m)
2.4-2.4835GHz	-	-	-	-	-	-	-	-	-	-
BT-LE(1Mbps)	Pass	AV	2.4835G	51.63	54.00	-2.37	3	Vertical	31	2.60
BT-LE(2Mbps)	Pass	AV	2.4835G	53.84	54.00	-0.16	3	Vertical	28	2.01



Result

Mode	Result	Type	Freq (Hz)	Level (dBuV/m)	Limit (dBuV/m)	Margin (dB)	Dist (m)	Condition	Azimuth (°)	Height (m)
BT-LE(1Mbps)	-	-	-	-	-	-	-	-	-	-
2402MHz	Pass	AV	2.39G	42.96	54.00	-11.04	3	Vertical	1	2.49
2402MHz	Pass	AV	2.402G	109.33	Inf	-Inf	3	Vertical	1	2.49
2402MHz	Pass	PK	2.3826G	56.18	74.00	-17.82	3	Vertical	1	2.49
2402MHz	Pass	PK	2.4022G	110.40	Inf	-Inf	3	Vertical	1	2.49
2402MHz	Pass	AV	2.3894G	43.26	54.00	-10.74	3	Horizontal	56	1.00
2402MHz	Pass	AV	2.402G	108.94	Inf	-Inf	3	Horizontal	56	1.00
2402MHz	Pass	PK	2.376G	56.21	74.00	-17.79	3	Horizontal	56	1.00
2402MHz	Pass	PK	2.4018G	109.99	Inf	-Inf	3	Horizontal	56	1.00
2402MHz	Pass	AV	4.80397G	27.74	54.00	-26.26	3	Vertical	358	1.00
2402MHz	Pass	PK	4.80437G	41.16	74.00	-32.84	3	Vertical	358	1.00
2402MHz	Pass	AV	4.80395G	28.98	54.00	-25.02	3	Horizontal	17	1.66
2402MHz	Pass	PK	4.80355G	42.20	74.00	-31.80	3	Horizontal	17	1.66
2440MHz	Pass	AV	2.3836G	43.00	54.00	-11.00	3	Vertical	338	1.00
2440MHz	Pass	AV	2.44G	111.96	Inf	-Inf	3	Vertical	338	1.00
2440MHz	Pass	AV	2.4904G	43.34	54.00	-10.66	3	Vertical	338	1.00
2440MHz	Pass	PK	2.3592G	56.32	74.00	-17.68	3	Vertical	338	1.00
2440MHz	Pass	PK	2.4396G	113.02	Inf	-Inf	3	Vertical	338	1.00
2440MHz	Pass	PK	2.498G	56.92	74.00	-17.08	3	Vertical	338	1.00
2440MHz	Pass	AV	2.3632G	43.09	54.00	-10.91	3	Horizontal	57	1.05
2440MHz	Pass	AV	2.44G	106.53	Inf	-Inf	3	Horizontal	57	1.05
2440MHz	Pass	AV	2.4936G	43.37	54.00	-10.63	3	Horizontal	57	1.05
2440MHz	Pass	PK	2.3764G	56.75	74.00	-17.25	3	Horizontal	57	1.05
2440MHz	Pass	PK	2.4396G	107.61	Inf	-Inf	3	Horizontal	57	1.05
2440MHz	Pass	PK	2.4968G	56.66	74.00	-17.34	3	Horizontal	57	1.05
2440MHz	Pass	AV	4.87993G	28.92	54.00	-25.08	3	Vertical	360	1.04
2440MHz	Pass	AV	7.3199G	41.69	54.00	-12.31	3	Vertical	56	1.92
2440MHz	Pass	PK	4.88099G	42.78	74.00	-31.22	3	Vertical	360	1.04
2440MHz	Pass	PK	7.3202G	50.47	74.00	-23.53	3	Vertical	56	1.92
2440MHz	Pass	AV	4.88001G	28.57	54.00	-25.43	3	Horizontal	267	1.83
2440MHz	Pass	AV	7.3199G	42.38	54.00	-11.62	3	Horizontal	44	1.01
2440MHz	Pass	PK	4.87759G	42.08	74.00	-31.92	3	Horizontal	267	1.83
2440MHz	Pass	PK	7.32019G	50.78	74.00	-23.22	3	Horizontal	44	1.01
2480MHz	Pass	AV	2.48G	110.36	Inf	-Inf	3	Vertical	31	2.60
2480MHz	Pass	AV	2.4835G	51.63	54.00	-2.37	3	Vertical	31	2.60
2480MHz	Pass	PK	2.4798G	111.39	Inf	-Inf	3	Vertical	31	2.60
2480MHz	Pass	PK	2.4835G	63.32	74.00	-10.68	3	Vertical	31	2.60
2480MHz	Pass	AV	2.48G	105.23	Inf	-Inf	3	Horizontal	358	1.00
2480MHz	Pass	AV	2.4835G	48.21	54.00	-5.79	3	Horizontal	358	1.00
2480MHz	Pass	PK	2.4802G	106.33	Inf	-Inf	3	Horizontal	358	1.00
2480MHz	Pass	PK	2.4835G	59.45	74.00	-14.55	3	Horizontal	358	1.00
2480MHz	Pass	AV	4.95771G	28.30	54.00	-25.70	3	Vertical	197	2.64
2480MHz	Pass	PK	4.9593G	42.59	74.00	-31.41	3	Vertical	197	2.64
2480MHz	Pass	AV	4.95764G	28.32	54.00	-25.68	3	Horizontal	2	2.55
2480MHz	Pass	AV	7.43989G	45.13	54.00	-8.87	3	Horizontal	9	1.50
2480MHz	Pass	PK	4.96086G	42.67	74.00	-31.33	3	Horizontal	2	2.55
2480MHz	Pass	PK	7.4402G	52.35	74.00	-21.65	3	Horizontal	9	1.50
BT-LE(2Mbps)	-	-	-	-	-	-	-	-	-	-
2402MHz	Pass	AV	2.3894G	43.28	54.00	-10.72	3	Vertical	4	1.11
2402MHz	Pass	AV	2.402G	107.91	Inf	-Inf	3	Vertical	4	1.11
2402MHz	Pass	PK	2.3898G	56.83	74.00	-17.17	3	Vertical	4	1.11
2402MHz	Pass	PK	2.4024G	110.81	Inf	-Inf	3	Vertical	4	1.11
2402MHz	Pass	AV	2.39G	43.73	54.00	-10.27	3	Horizontal	56	1.00
2402MHz	Pass	AV	2.402G	107.95	Inf	-Inf	3	Horizontal	56	1.00
2402MHz	Pass	PK	2.3784G	56.12	74.00	-17.88	3	Horizontal	56	1.00
2402MHz	Pass	PK	2.4014G	110.79	Inf	-Inf	3	Horizontal	56	1.00
2402MHz	Pass	AV	4.80472G	26.78	54.00	-27.22	3	Vertical	235	2.76
2402MHz	Pass	PK	4.80617G	40.64	74.00	-33.36	3	Vertical	235	2.76
2402MHz	Pass	AV	4.80623G	26.82	54.00	-27.18	3	Horizontal	243	1.82
2402MHz	Pass	PK	4.80595G	41.22	74.00	-32.78	3	Horizontal	243	1.82
2440MHz	Pass	AV	2.39G	42.98	54.00	-11.02	3	Vertical	339	1.00



Mode	Result	Type	Freq (Hz)	Level (dBuV/m)	Limit (dBuV/m)	Margin (dB)	Dist (m)	Condition	Azimuth (°)	Height (m)
2440MHz	Pass	AV	2.44G	110.77	Inf	-Inf	3	Vertical	339	1.00
2440MHz	Pass	AV	2.4996G	43.36	54.00	-10.64	3	Vertical	339	1.00
2440MHz	Pass	PK	2.3692G	57.00	74.00	-17.00	3	Vertical	339	1.00
2440MHz	Pass	PK	2.4396G	113.58	Inf	-Inf	3	Vertical	339	1.00
2440MHz	Pass	PK	2.4864G	57.17	74.00	-16.83	3	Vertical	339	1.00
2440MHz	Pass	AV	2.3892G	42.95	54.00	-11.05	3	Horizontal	57	1.04
2440MHz	Pass	AV	2.44G	104.95	Inf	-Inf	3	Horizontal	57	1.04
2440MHz	Pass	AV	2.4976G	43.29	54.00	-10.71	3	Horizontal	57	1.04
2440MHz	Pass	PK	2.3784G	56.74	74.00	-17.26	3	Horizontal	57	1.04
2440MHz	Pass	PK	2.4396G	107.80	Inf	-Inf	3	Horizontal	57	1.04
2440MHz	Pass	PK	2.4924G	56.57	74.00	-17.43	3	Horizontal	57	1.04
2440MHz	Pass	AV	4.87971G	27.98	54.00	-26.02	3	Vertical	42	1.95
2440MHz	Pass	AV	7.32107G	37.23	54.00	-16.77	3	Vertical	57	1.90
2440MHz	Pass	PK	4.88038G	41.53	74.00	-32.47	3	Vertical	42	1.95
2440MHz	Pass	PK	7.3213G	50.44	74.00	-23.56	3	Vertical	57	1.90
2440MHz	Pass	AV	4.87953G	27.97	54.00	-26.03	3	Horizontal	157	2.21
2440MHz	Pass	AV	7.32106G	37.92	54.00	-16.08	3	Horizontal	44	1.00
2440MHz	Pass	PK	4.87869G	41.84	74.00	-32.16	3	Horizontal	157	2.21
2440MHz	Pass	PK	7.32114G	50.25	74.00	-23.75	3	Horizontal	44	1.00
2478MHz	Pass	AV	2.478G	96.45	Inf	-Inf	3	Vertical	25	2.54
2478MHz	Pass	AV	2.4836G	44.10	54.00	-9.90	3	Vertical	25	2.54
2478MHz	Pass	PK	2.4776G	99.28	Inf	-Inf	3	Vertical	25	2.54
2478MHz	Pass	PK	2.4976G	57.22	74.00	-16.78	3	Vertical	25	2.54
2478MHz	Pass	AV	2.478G	91.50	Inf	-Inf	3	Horizontal	57	1.46
2478MHz	Pass	AV	2.4838G	43.54	54.00	-10.46	3	Horizontal	57	1.46
2478MHz	Pass	PK	2.4776G	94.33	Inf	-Inf	3	Horizontal	57	1.46
2478MHz	Pass	PK	2.4922G	56.41	74.00	-17.59	3	Horizontal	57	1.46
2478MHz	Pass	AV	4.95532G	28.82	54.00	-25.18	3	Vertical	63	1.50
2478MHz	Pass	AV	7.43524G	33.94	54.00	-20.06	3	Vertical	0	1.63
2478MHz	Pass	PK	4.95371G	42.57	74.00	-31.43	3	Vertical	63	1.50
2478MHz	Pass	PK	7.43488G	47.46	74.00	-26.54	3	Vertical	0	1.63
2478MHz	Pass	AV	4.95515G	29.67	54.00	-24.33	3	Horizontal	33	1.51
2478MHz	Pass	AV	7.43263G	34.15	54.00	-19.85	3	Horizontal	310	1.24
2478MHz	Pass	PK	4.95509G	43.32	74.00	-30.68	3	Horizontal	33	1.51
2478MHz	Pass	PK	7.43571G	47.73	74.00	-26.27	3	Horizontal	310	1.24
2480MHz	Pass	AV	2.48G	107.03	Inf	-Inf	3	Vertical	28	2.01
2480MHz	Pass	AV	2.4835G	53.84	54.00	-0.16	3	Vertical	28	2.01
2480MHz	Pass	PK	2.4804G	109.84	Inf	-Inf	3	Vertical	28	2.01
2480MHz	Pass	PK	2.4835G	67.19	74.00	-6.81	3	Vertical	28	2.01
2480MHz	Pass	AV	2.48G	101.72	Inf	-Inf	3	Horizontal	356	1.01
2480MHz	Pass	AV	2.4835G	49.89	54.00	-4.11	3	Horizontal	356	1.01
2480MHz	Pass	PK	2.4804G	104.59	Inf	-Inf	3	Horizontal	356	1.01
2480MHz	Pass	PK	2.4835G	61.47	74.00	-12.53	3	Horizontal	356	1.01
2480MHz	Pass	AV	4.95767G	28.32	54.00	-25.68	3	Vertical	142	2.49
2480MHz	Pass	AV	7.43873G	37.57	54.00	-16.43	3	Vertical	354	1.43
2480MHz	Pass	PK	4.96002G	42.88	74.00	-31.12	3	Vertical	142	2.49
2480MHz	Pass	PK	7.43849G	49.97	74.00	-24.03	3	Vertical	354	1.43
2480MHz	Pass	AV	4.95917G	28.32	54.00	-25.68	3	Horizontal	71	1.15
2480MHz	Pass	AV	7.43874G	37.61	54.00	-16.39	3	Horizontal	9	1.50
2480MHz	Pass	PK	4.95922G	42.43	74.00	-31.57	3	Horizontal	71	1.15
2480MHz	Pass	PK	7.43848G	50.31	74.00	-23.69	3	Horizontal	9	1.50

2.4-2.4835GHz_BT-LE(1Mbps)

2480MHz_TX

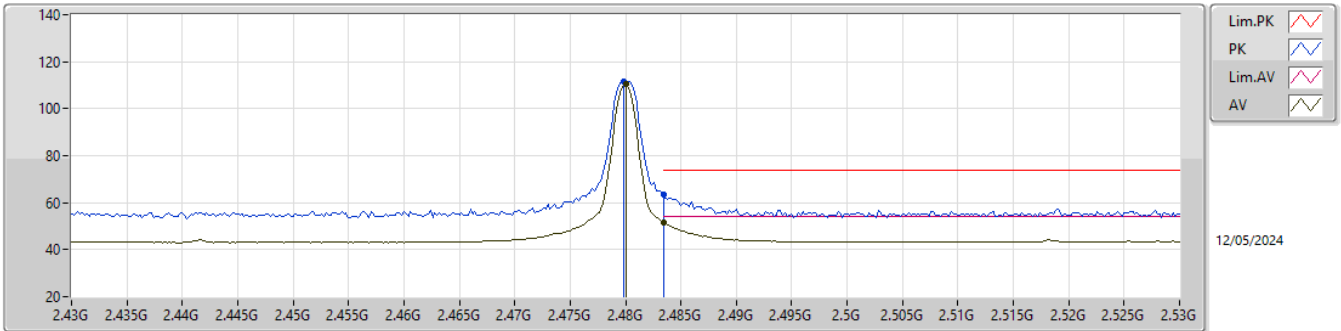

Type	Freq (Hz)	Level (dBuV/m)	Limit (dBuV/m)	Margin (dB)	Factor (dB)	Dist (m)	Condition	Azimuth (°)	Height (m)	Raw (dBuV)	AF (dB)	CL (dB)	PA (dB)
AV	2.48G	110.36	Inf	-Inf	31.50	3	Vertical	31	2.60	78.86	27.80	3.70	-
AV	2.4835G	51.63	54.00	-2.37	31.51	3	Vertical	31	2.60	20.12	27.80	3.71	-
PK	2.4798G	111.39	Inf	-Inf	31.50	3	Vertical	31	2.60	79.89	27.80	3.70	-
PK	2.4835G	63.32	74.00	-10.68	31.51	3	Vertical	31	2.60	31.81	27.80	3.71	-

2.4-2.4835GHz_BT-LE(1Mbps)

2480MHz_TX

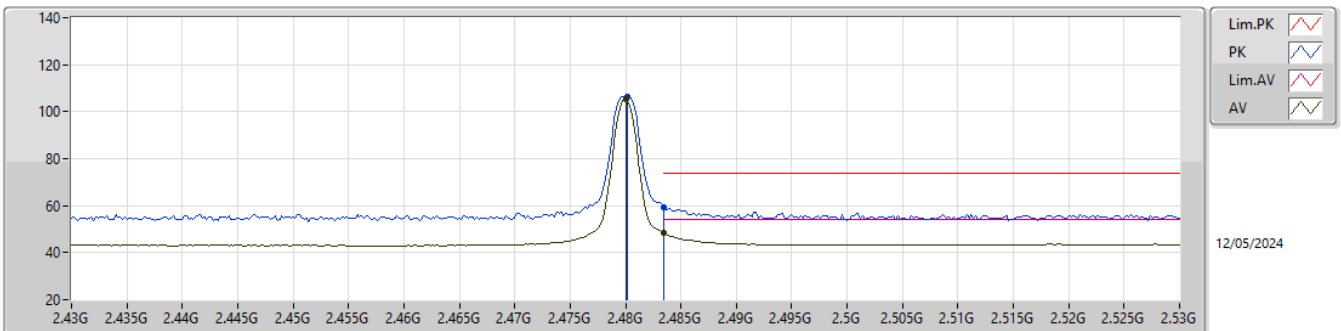

Type	Freq (Hz)	Level (dBuV/m)	Limit (dBuV/m)	Margin (dB)	Factor (dB)	Dist (m)	Condition	Azimuth (°)	Height (m)	Raw (dBuV)	AF (dB)	CL (dB)	PA (dB)
AV	2.48G	105.23	Inf	-Inf	31.50	3	Horizontal	358	1.00	73.73	27.80	3.70	-
AV	2.4835G	48.21	54.00	-5.79	31.51	3	Horizontal	358	1.00	16.70	27.80	3.71	-
PK	2.4802G	106.33	Inf	-Inf	31.50	3	Horizontal	358	1.00	74.83	27.80	3.70	-
PK	2.4835G	59.45	74.00	-14.55	31.51	3	Horizontal	358	1.00	27.94	27.80	3.71	-

2.4-2.4835GHz_BT-LE(1Mbps)

2480MHz_TX

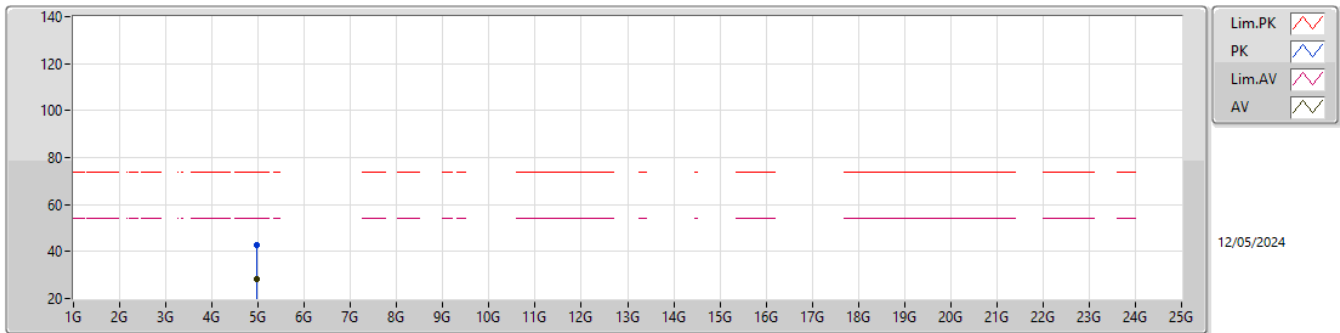

Type	Freq (Hz)	Level (dBuV/m)	Limit (dBuV/m)	Margin (dB)	Factor (dB)	Dist (m)	Condition	Azimuth (°)	Height (m)	Raw (dBuV)	AF (dB)	CL (dB)	PA (dB)
AV	4.95771G	28.30	54.00	-25.70	1.26	3	Vertical	197	2.64	27.04	33.15	5.36	37.25
PK	4.9593G	42.59	74.00	-31.41	1.27	3	Vertical	197	2.64	41.32	33.16	5.36	37.25

2.4-2.4835GHz_BT-LE(1Mbps)

2480MHz_TX

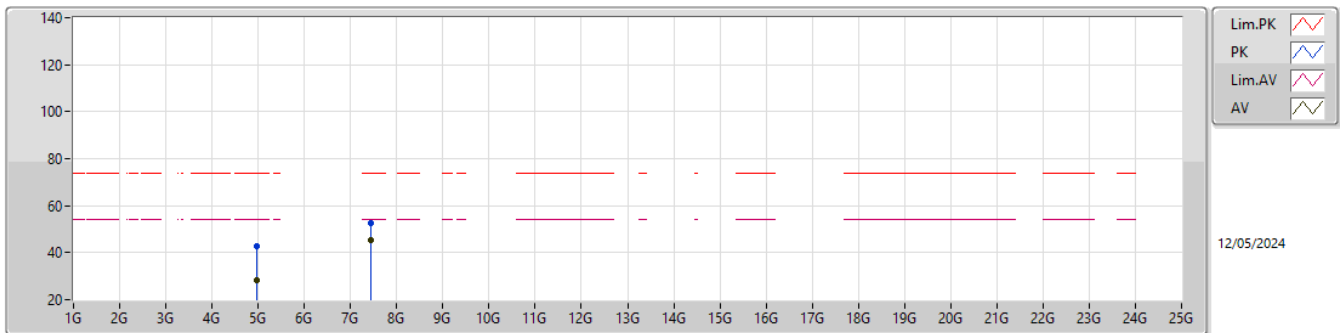

Type	Freq (Hz)	Level (dBuV/m)	Limit (dBuV/m)	Margin (dB)	Factor (dB)	Dist (m)	Condition	Azimuth (°)	Height (m)	Raw (dBuV)	AF (dB)	CL (dB)	PA (dB)
AV	4.95764G	28.32	54.00	-25.68	1.26	3	Horizontal	2	2.55	27.06	33.15	5.36	37.25
AV	7.43989G	45.13	54.00	-8.87	6.93	3	Horizontal	9	1.50	38.20	36.72	6.72	36.51
PK	4.96086G	42.67	74.00	-31.33	1.29	3	Horizontal	2	2.55	41.38	33.17	5.36	37.24
PK	7.4402G	52.35	74.00	-21.65	6.93	3	Horizontal	9	1.50	45.42	36.72	6.72	36.51

2.4-2.4835GHz_BT-LE(2Mbps)

2480MHz_TX

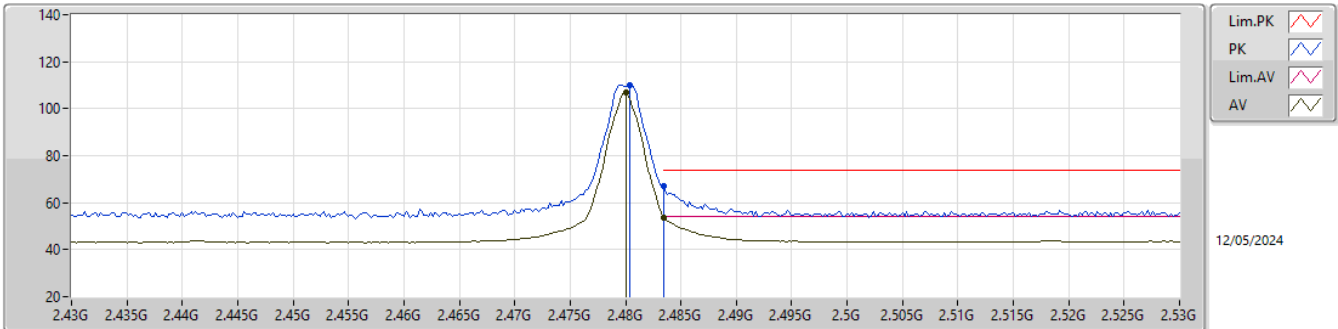

Type	Freq (Hz)	Level (dBuV/m)	Limit (dBuV/m)	Margin (dB)	Factor (dB)	Dist (m)	Condition	Azimuth (°)	Height (m)	Raw (dBuV)	AF (dB)	CL (dB)	PA (dB)
AV	2.48G	107.03	Inf	-Inf	31.50	3	Vertical	28	2.01	75.53	27.80	3.70	-
AV	2.4835G	53.84	54.00	-0.16	31.51	3	Vertical	28	2.01	22.33	27.80	3.71	-
PK	2.4804G	109.84	Inf	-Inf	31.50	3	Vertical	28	2.01	78.34	27.80	3.70	-
PK	2.4835G	67.19	74.00	-6.81	31.51	3	Vertical	28	2.01	35.68	27.80	3.71	-

2.4-2.4835GHz_BT-LE(2Mbps)

2480MHz_TX

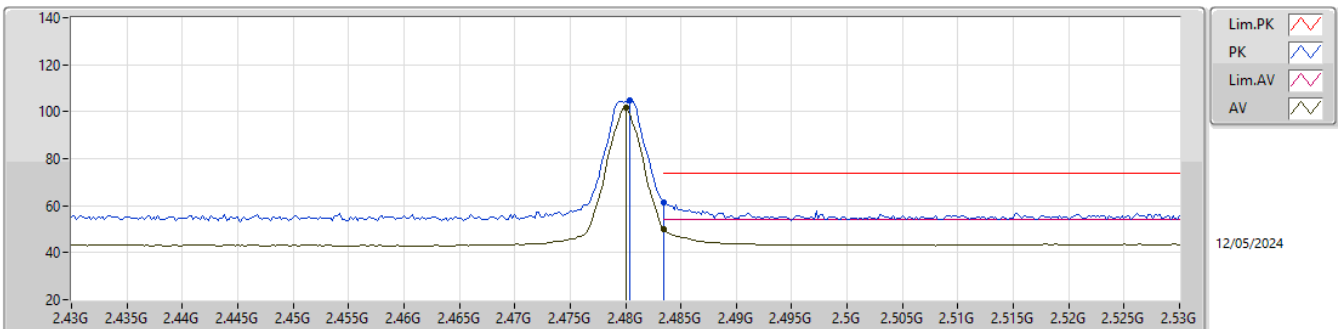

Type	Freq (Hz)	Level (dBuV/m)	Limit (dBuV/m)	Margin (dB)	Factor (dB)	Dist (m)	Condition	Azimuth (°)	Height (m)	Raw (dBuV)	AF (dB)	CL (dB)	PA (dB)
AV	2.48G	101.72	Inf	-Inf	31.50	3	Horizontal	356	1.01	70.22	27.80	3.70	-
AV	2.4835G	49.89	54.00	-4.11	31.51	3	Horizontal	356	1.01	18.38	27.80	3.71	-
PK	2.4804G	104.59	Inf	-Inf	31.50	3	Horizontal	356	1.01	73.09	27.80	3.70	-
PK	2.4835G	61.47	74.00	-12.53	31.51	3	Horizontal	356	1.01	29.96	27.80	3.71	-

2.4-2.4835GHz_BT-LE(2Mbps)

2480MHz_TX

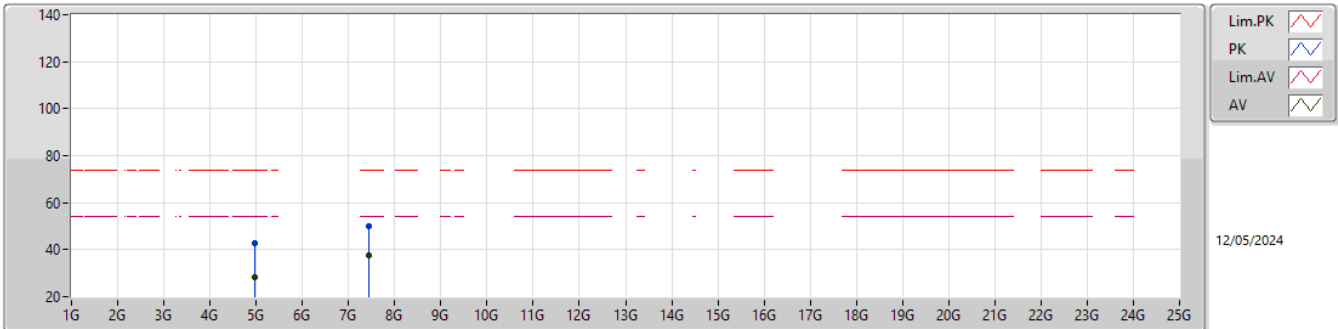

Type	Freq (Hz)	Level (dBuV/m)	Limit (dBuV/m)	Margin (dB)	Factor (dB)	Dist (m)	Condition	Azimuth (°)	Height (m)	Raw (dBuV)	AF (dB)	CL (dB)	PA (dB)
AV	4.95767G	28.32	54.00	-25.68	1.26	3	Vertical	142	2.49	27.06	33.15	5.36	37.25
AV	7.43873G	37.57	54.00	-16.43	6.93	3	Vertical	354	1.43	30.64	36.72	6.72	36.51
PK	4.96002G	42.88	74.00	-31.12	1.28	3	Vertical	142	2.49	41.60	33.16	5.36	37.24
PK	7.43849G	49.97	74.00	-24.03	6.93	3	Vertical	354	1.43	43.04	36.72	6.72	36.51

2.4-2.4835GHz_BT-LE(2Mbps)

2480MHz_TX

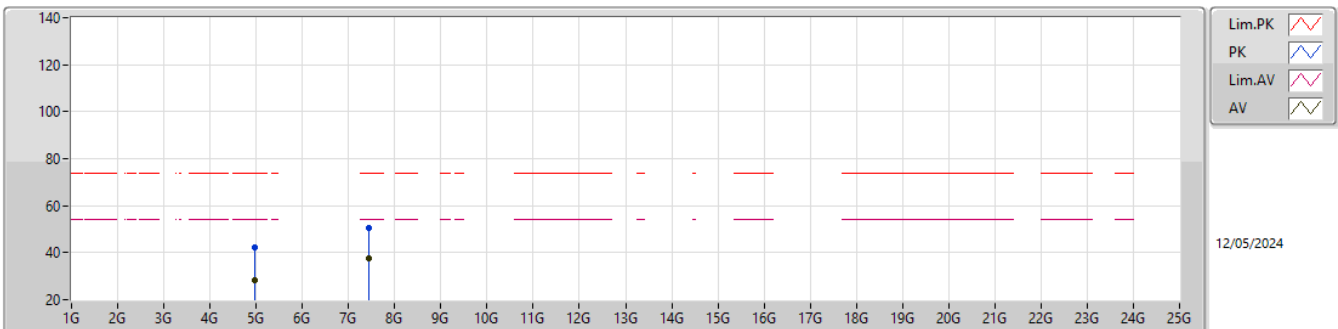

Type	Freq (Hz)	Level (dBuV/m)	Limit (dBuV/m)	Margin (dB)	Factor (dB)	Dist (m)	Condition	Azimuth (°)	Height (m)	Raw (dBuV)	AF (dB)	CL (dB)	PA (dB)
AV	4.95917G	28.32	54.00	-25.68	1.27	3	Horizontal	71	1.15	27.05	33.16	5.36	37.25
AV	7.43874G	37.61	54.00	-16.39	6.93	3	Horizontal	9	1.50	30.68	36.72	6.72	36.51
PK	4.95922G	42.43	74.00	-31.57	1.27	3	Horizontal	71	1.15	41.16	33.16	5.36	37.25
PK	7.43848G	50.31	74.00	-23.69	6.93	3	Horizontal	9	1.50	43.38	36.72	6.72	36.51



Summary

Mode	Result	Type	Freq (Hz)	Level (dBuV/m)	Limit (dBuV/m)	Margin (dB)	Condition
Mode 1	Pass	AV	7.47549G	36.43	54.00	-17.57	Vertical
Mode 2	Pass	AV	7.32021G	36.78	54.00	-17.22	Vertical



Result

Mode	Result	Type	Freq (Hz)	Level (dBuV/m)	Limit (dBuV/m)	Margin (dB)	Dist (m)	Condition	Azimuth (°)	Height (m)
Mode 1	Pass	AV	1.12017G	20.28	54.00	-33.72	3	Vertical	34	1.16
Mode 1	Pass	AV	2.1295G	23.74	68.20	-44.46	3	Vertical	33	1.65
Mode 1	Pass	AV	7.47549G	36.43	54.00	-17.57	3	Vertical	35	2.20
Mode 1	Pass	PK	1.12017G	40.01	74.00	-33.99	3	Vertical	34	1.16
Mode 1	Pass	PK	2.1295G	42.72	88.20	-45.48	3	Vertical	33	1.65
Mode 1	Pass	PK	7.47549G	50.36	74.00	-23.64	3	Vertical	35	2.20
Mode 1	Pass	AV	1.41494G	21.63	54.00	-32.37	3	Horizontal	39	2.27
Mode 1	Pass	AV	2.12742G	23.59	68.20	-44.61	3	Horizontal	167	1.36
Mode 1	Pass	AV	4.27071G	29.03	54.00	-24.97	3	Horizontal	75	1.62
Mode 1	Pass	PK	1.41494G	35.48	74.00	-38.52	3	Horizontal	39	2.27
Mode 1	Pass	PK	2.12742G	43.97	88.20	-44.23	3	Horizontal	167	1.36
Mode 1	Pass	PK	4.27071G	42.94	74.00	-31.06	3	Horizontal	75	1.62
Mode 2	Pass	AV	1.11992G	20.09	54.00	-33.91	3	Vertical	18	1.07
Mode 2	Pass	AV	2.42724G	22.52	68.20	-45.68	3	Vertical	55	2.49
Mode 2	Pass	AV	7.32021G	36.78	54.00	-17.22	3	Vertical	16	1.58
Mode 2	Pass	PK	1.11992G	40.07	74.00	-33.93	3	Vertical	18	1.07
Mode 2	Pass	PK	2.42724G	43.03	88.20	-45.17	3	Vertical	55	2.49
Mode 2	Pass	PK	7.32021G	51.19	74.00	-22.81	3	Vertical	16	1.58
Mode 2	Pass	AV	2.79333G	25.26	54.00	-28.74	3	Horizontal	129	1.44
Mode 2	Pass	AV	3.88032G	28.09	54.00	-25.91	3	Horizontal	172	1.35
Mode 2	Pass	AV	4.85736G	31.09	54.00	-22.91	3	Horizontal	315	2.04
Mode 2	Pass	PK	2.79333G	39.39	74.00	-34.61	3	Horizontal	129	1.44
Mode 2	Pass	PK	3.88032G	42.46	74.00	-31.54	3	Horizontal	172	1.35
Mode 2	Pass	PK	4.85736G	45.83	74.00	-28.17	3	Horizontal	315	2.04

Radiated Emissions above 1GHz_Mode 1

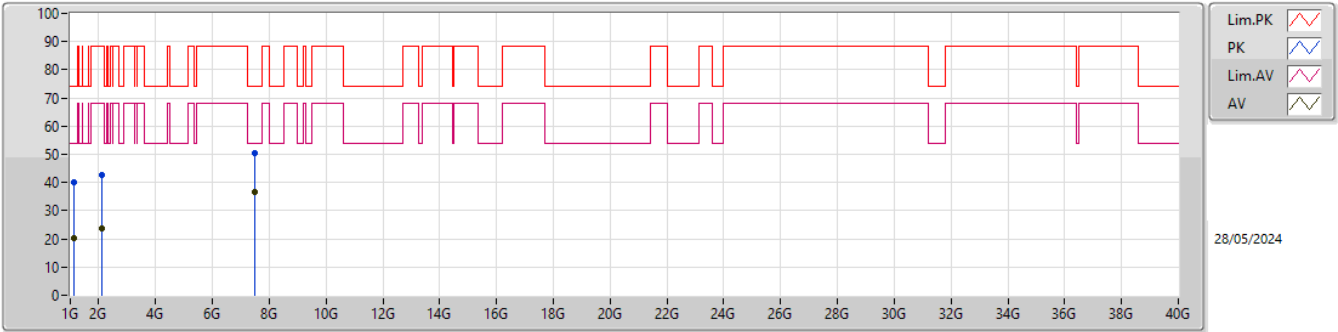

Type	Freq (Hz)	Level (dBuV/m)	Limit (dBuV/m)	Margin (dB)	Factor (dB/m)	Dist (m)	Condition	Azimuth (°)	Height (m)	Comment	Raw (dBuV/m)	AF (dB/m)	CL (dB)	PA (dB)
AV	1.12017G	20.28	54.00	-33.72	-16.02	3	Vertical	34	1.16	-	36.30	25.60	3.10	44.72
AV	2.1295G	23.74	68.20	-44.46	-13.22	3	Vertical	33	1.65	-	36.96	27.40	4.27	44.89
AV	7.47549G	36.43	54.00	-17.57	-0.52	3	Vertical	35	2.20	-	36.95	36.40	8.13	45.05
PK	1.12017G	40.01	74.00	-33.99	-16.02	3	Vertical	34	1.16	-	56.03	25.60	3.10	44.72
PK	2.1295G	42.72	88.20	-45.48	-13.22	3	Vertical	33	1.65	-	55.94	27.40	4.27	44.89
PK	7.47549G	50.36	74.00	-23.64	-0.52	3	Vertical	35	2.20	-	50.88	36.40	8.13	45.05

Radiated Emissions above 1GHz_Mode 1

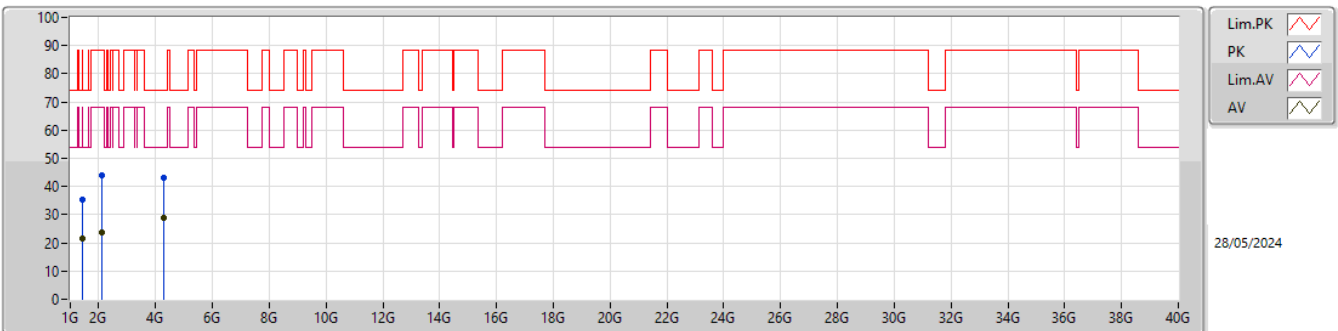

Type	Freq (Hz)	Level (dBuV/m)	Limit (dBuV/m)	Margin (dB)	Factor (dB/m)	Dist (m)	Condition	Azimuth (°)	Height (m)	Comment	Raw (dBuV/m)	AF (dB/m)	CL (dB)	PA (dB)
AV	1.41494G	21.63	54.00	-32.37	-15.22	3	Horizontal	39	2.27	-	36.85	26.10	3.45	44.77
AV	2.12742G	23.59	68.20	-44.61	-13.19	3	Horizontal	167	1.36	-	36.78	27.43	4.27	44.89
AV	4.27071G	29.03	54.00	-24.97	-8.28	3	Horizontal	75	1.62	-	37.31	31.38	6.15	45.81
PK	1.41494G	35.48	74.00	-38.52	-15.22	3	Horizontal	39	2.27	-	50.70	26.10	3.45	44.77
PK	2.12742G	43.97	88.20	-44.23	-13.19	3	Horizontal	167	1.36	-	57.16	27.43	4.27	44.89
PK	4.27071G	42.94	74.00	-31.06	-8.28	3	Horizontal	75	1.62	-	51.22	31.38	6.15	45.81

Radiated Emissions above 1GHz_Mode 2

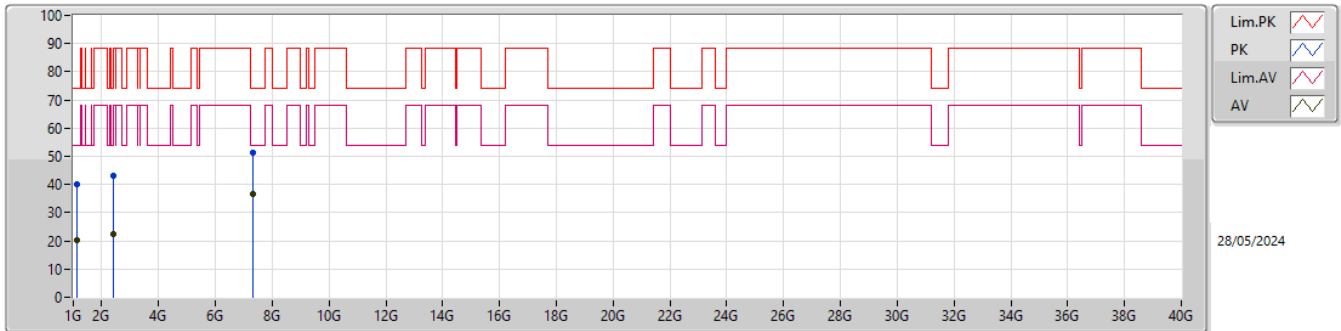

28/05/2024

Type	Freq (Hz)	Level (dBuV/m)	Limit (dBuV/m)	Margin (dB)	Factor (dB/m)	Dist (m)	Condition	Azimuth (°)	Height (m)	Comment	Raw (dBuV/m)	AF (dB/m)	CL (dB)	PA (dB)
AV	1.11992G	20.09	54.00	-33.91	-16.02	3	Vertical	18	1.07	-	36.11	25.60	3.10	44.72
AV	2.42724G	22.52	68.20	-45.68	-12.77	3	Vertical	55	2.49	-	35.29	27.57	4.62	44.96
AV	7.32021G	36.78	54.00	-17.22	-0.14	3	Vertical	16	1.58	-	36.92	37.08	8.05	45.27
PK	1.11992G	40.07	74.00	-33.93	-16.02	3	Vertical	18	1.07	-	56.09	25.60	3.10	44.72
PK	2.42724G	43.03	88.20	-45.17	-12.77	3	Vertical	55	2.49	-	55.80	27.57	4.62	44.96
PK	7.32021G	51.19	74.00	-22.81	-0.14	3	Vertical	16	1.58	-	51.33	37.08	8.05	45.27

Radiated Emissions above 1GHz_Mode 2

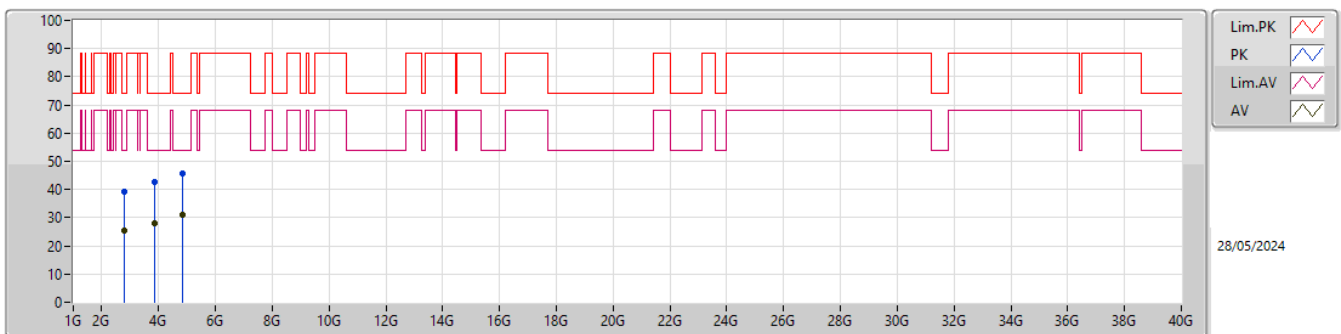

28/05/2024

Type	Freq (Hz)	Level (dBuV/m)	Limit (dBuV/m)	Margin (dB)	Factor (dB/m)	Dist (m)	Condition	Azimuth (°)	Height (m)	Comment	Raw (dBuV/m)	AF (dB/m)	CL (dB)	PA (dB)
AV	2.79333G	25.26	54.00	-28.74	-11.65	3	Horizontal	129	1.44	-	36.91	28.53	4.91	45.09
AV	3.88032G	28.09	54.00	-25.91	-8.94	3	Horizontal	172	1.35	-	37.03	30.88	5.86	45.68
AV	4.85736G	31.09	54.00	-22.91	-6.22	3	Horizontal	315	2.04	-	37.31	32.61	6.94	45.77
PK	2.79333G	39.39	74.00	-34.61	-11.65	3	Horizontal	129	1.44	-	51.04	28.53	4.91	45.09
PK	3.88032G	42.46	74.00	-31.54	-8.94	3	Horizontal	172	1.35	-	51.40	30.88	5.86	45.68
PK	4.85736G	45.83	74.00	-28.17	-6.22	3	Horizontal	315	2.04	-	52.05	32.61	6.94	45.77