

FCC Test Report

Report No.: RF150728C08

FCC ID: TVE-23155111

Test Model: FORTIWIFI-60E-DR

Series Model: FORTIWIFI-60E-DRxxxxxx, FWF-60E-DRxxxxxx (where "x" can be used for "A-Z", or "0-9", or "-", or blank for software changes or marketing purposes only)

Received Date: Aug. 07, 2015

Test Date: Sep. 03 ~ Sep. 08, 2015

Issued Date: Oct. 06, 2015

Applicant: Fortinet Inc.

Address: 899 Kifer Road Sunnyvale, CA 94086 USA

Issued By: Bureau Veritas Consumer Products Services (H.K.) Ltd., Taoyuan Branch

Lab Address: No. 47-2, 14th Ling, Chia Pau Vil., Lin Kou Dist., New Taipei City, Taiwan

Test Location: No. 19, Hwa Ya 2nd Rd., Wen Hwa Vil., Kwei Shan Dist., Taoyuan City 33383, TAIWAN (R.O.C.)



This report is for your exclusive use. Any copying or replication of this report to or for any other person or entity, or use of our name or trademark, is permitted only with our prior written permission. This report sets forth our findings solely with respect to the test samples identified herein. The results set forth in this report are not indicative or representative of the quality or characteristics of the lot from which a test sample was taken or any similar or identical product unless specifically and expressly noted. Our report includes all of the tests requested by you and the results thereof based upon the information that you provided to us. You have 60 days from date of issuance of this report to notify us of any material error or omission caused by our negligence, provided, however, that such notice shall be in writing and shall specifically address the issue you wish to raise. A failure to raise such issue within the prescribed time shall constitute your unqualified acceptance of the completeness of this report, the tests conducted and the correctness of the report contents. Unless specific mention, the uncertainty of measurement has been explicitly taken into account to declare the compliance or non-compliance to the specification. This report should not be used by the client to claim product certification, approval, or endorsement by TAF or any government agencies.



Table of Contents

Release Control Record	4
1 Certificate of Conformity	5
2 Summary of Test Results	6
2.1 Measurement Uncertainty.....	6
2.2 Modification Record.....	6
3 General Information	7
3.1 General Description of EUT.....	7
3.2 Description of Test Modes.....	9
3.2.1 Test Mode Applicability and Tested Channel Detail.....	10
3.3 Duty Cycle of Test Signal.....	12
3.4 Description of Support Units.....	13
3.4.1 Configuration of System under Test.....	13
3.5 General Description of Applied Standards.....	14
4 Test Types and Results	15
4.1 Radiated Emission and Bandedge Measurement.....	15
4.1.1 Limits of Radiated Emission and Bandedge Measurement.....	15
4.1.2 Test Instruments.....	16
4.1.3 Test Procedures.....	17
4.1.4 Deviation from Test Standard.....	17
4.1.5 Test Set Up.....	18
4.1.6 EUT Operating Conditions.....	18
4.1.7 Test Results.....	19
4.2 Conducted Emission Measurement.....	32
4.2.1 Limits of Conducted Emission Measurement.....	32
4.2.2 Test Instruments.....	32
4.2.3 Test Procedures.....	33
4.2.4 Deviation from Test Standard.....	33
4.2.5 Test Setup.....	33
4.2.6 EUT Operating Conditions.....	33
4.2.7 Test Results.....	34
4.3 6dB Bandwidth Measurement.....	36
4.3.1 Limits of 6dB Bandwidth Measurement.....	36
4.3.2 Test Setup.....	36
4.3.3 Test Instruments.....	36
4.3.4 Test Procedure.....	36
4.3.5 Deviation from Test Standard.....	36
4.3.6 EUT Operating Conditions.....	36
4.3.7 Test Result.....	37
4.4 Conducted Output Power Measurement.....	39
4.4.1 Limits of Conducted Output Power Measurement.....	39
4.4.2 Test Setup.....	39
4.4.3 Test Instruments.....	39
4.4.4 Test Procedures.....	39
4.4.5 Deviation from Test Standard.....	39
4.4.6 EUT Operating Conditions.....	39
4.4.7 Test Results.....	40
4.5 Power Spectral Density Measurement.....	41
4.5.1 Limits of Power Spectral Density Measurement.....	41
4.5.2 Test Setup.....	41
4.5.3 Test Instruments.....	41
4.5.4 Test Procedure.....	41
4.5.5 Deviation from Test Standard.....	41
4.5.6 EUT Operating Condition.....	41



4.5.7 Test Results	42
4.6 Conducted Out of Band Emission Measurement.....	45
4.6.1 Limits of Conducted Out of Band Emission Measurement	45
4.6.2 Test Setup.....	45
4.6.3 Test Instruments	45
4.6.4 Test Procedure	45
4.6.5 Deviation from Test Standard	45
4.6.6 EUT Operating Condition	45
4.6.7 Test Results	45
5 Pictures of Test Arrangements.....	58
Appendix – Information on the Testing Laboratories	59



A D T

Release Control Record

Issue No.	Description	Date Issued
RF150728C08	Original release.	Oct. 06, 2015

1 Certificate of Conformity

Product: Network Security Gateway

Brand: Fortinet Inc.

Test Model: FORTIWIFI-60E-DR

Series Model: FORTIWIFI-60E-DRxxxxxx, FWF-60E-DRxxxxxx (where "x" can be used for "A-Z", or "0-9", or "-", or blank for software changes or marketing purposes only)

Sample Status: Engineering sample

Applicant: Fortinet Inc.

Test Date: Sep. 03 ~ Sep. 08, 2015

Standards: 47 CFR FCC Part 15, Subpart C (Section 15.247)
ANSI C63.10:2013

The above equipment has been tested by **Bureau Veritas Consumer Products Services (H.K.) Ltd., Taoyuan Branch**, and found compliance with the requirement of the above standards. The test record, data evaluation & Equipment Under Test (EUT) configurations represented herein are true and accurate accounts of the measurements of the sample's EMC characteristics under the conditions specified in this report.

Prepared by :  , **Date:** Oct. 06, 2015
Pettie Chen / Senior Specialist

Approved by :  , **Date:** Oct. 06, 2015
Ken Liu / Senior Manager

2 Summary of Test Results

47 CFR FCC Part 15, Subpart C (SECTION 15.247)			
FCC Clause	Test Item	Result	Remarks
15.207	AC Power Conducted Emission	PASS	Meet the requirement of limit. Minimum passing margin is -21.07dB at 0.49375MHz.
15.205 / 15.209 / 15.247(d)	Radiated Emissions and Band Edge Measurement	PASS	Meet the requirement of limit. Minimum passing margin is -1.0dB at 2390.00, 2483.50MHz.
15.247(d)	Antenna Port Emission	PASS	Meet the requirement of limit.
15.247(a)(2)	6dB bandwidth	PASS	Meet the requirement of limit.
15.247(b)	Conducted power	PASS	Meet the requirement of limit.
15.247(e)	Power Spectral Density	PASS	Meet the requirement of limit.
15.203	Antenna Requirement	Pass	Antenna connector is RP-SMA not a standard connector.

2.1 Measurement Uncertainty

Where relevant, the following measurement uncertainty levels have been estimated for tests performed on the EUT as specified in CISPR 16-4-2:

Measurement	Frequency	Expanded Uncertainty (k=2) (\pm)
Conducted Emissions at mains ports	150kHz ~ 30MHz	2.44 dB
Radiated Emissions up to 1 GHz	30MHz ~ 200MHz	3.86 dB
	200MHz ~ 1000MHz	3.87 dB
Radiated Emissions above 1 GHz	1GHz ~ 18GHz	2.29 dB
	18GHz ~ 40GHz	2.29 dB

2.2 Modification Record

There were no modifications required for compliance.

3 General Information

3.1 General Description of EUT

Product	Network Security Gateway
Brand	Fortinet Inc.
Test Model	FORTIWIFI-60E-DR
Series Model	FORTIWIFI-60E-DRxxxxxx, FWF-60E-DRxxxxxx (where “x” can be used for “A-Z”, or “0-9”, or “-”, or blank for software changes or marketing purposes only)
Model Difference	Refer to note
Status of EUT	Engineering sample
Power Supply Rating	12Vdc from adapter
Modulation Type	CCK, DQPSK, DBPSK for DSSS 64QAM, 16QAM, QPSK, BPSK for OFDM
Modulation Technology	DSSS, OFDM
Transfer Rate	802.11b:11.0/ 5.5/ 2.0/ 1.0Mbps 802.11g: 54.0/ 48.0/ 36.0/ 24.0/ 18.0/ 12.0/ 9.0/ 6.0Mbps 802.11n: up to 450.0Mbps
Operating Frequency	2412 ~ 2462MHz
Number of Channel	11 for 802.11b, 802.11g, 802.11n (HT20) 7 for 802.11n (HT40)
Output Power	730.602mW
Antenna Type	Refer to Note
Antenna Connector	Refer to Note
Accessory Device	NA
Data Cable Supplied	1.85m non-shielded console cable without core 2.2m non-shielded RJ45 cable without core

Note:

1. All models are listed as below.

Brand	Model	
Fortinet Inc.	FORTIWIFI-60E-DRxxxxxx (Main test model: FORTIWIFI-60E-DR)	where “x” can be used for “A-Z”, or “0-9”, or “-”, or blank for software changes or marketing purposes only
	FWF-60E-DRxxxxxx	

2. The EUT incorporates a MIMO function. Physically, the EUT provides 3 completed transmitters and 3 receivers.

Modulation Mode	TX Function
802.11b	3TX
802.11g	3TX
802.11n (HT20)	3TX
802.11n (HT40)	3TX

* The EUT doesn't support diversity function.

3. The EUT consumes power from the following adapter.

Adapter	
Brand	Asian Power Devices Inc.
Model	WA-30B12
Input Power	100-240Vac~50-60Hz, 0.8A Max
Output Power	12Vdc / 2.5A
Power Line	DC 1.5m power cable with 1 core attached on adapter

4. The following antennas were provided to the EUT.

Type	Gain(dBi)		Connector
	2.4GHz Band	5GHz Band	
Dipole	3dBi	3dBi	RP-SMA

5. The above EUT information is declared by manufacturer and for more detailed features description, please refer to the manufacturer's specifications or user's manual.

3.2 Description of Test Modes

11 channels are provided for 802.11b, 802.11g and 802.11n (HT20):

Channel	Frequency	Channel	Frequency
1	2412MHz	7	2442MHz
2	2417MHz	8	2447MHz
3	2422MHz	9	2452MHz
4	2427MHz	10	2457MHz
5	2432MHz	11	2462MHz
6	2437MHz		

7 channels are provided for 802.11n (HT40):

Channel	Frequency	Channel	Frequency
3	2422MHz	7	2442MHz
4	2427MHz	8	2447MHz
5	2432MHz	9	2452MHz
6	2437MHz		

3.2.1 Test Mode Applicability and Tested Channel Detail

EUT CONFIGURE MODE	APPLICABLE TO				DESCRIPTION
	RE≥1G	RE<1G	PLC	APCM	
-	√	√	√	√	-

Where **RE≥1G**: Radiated Emission above 1GHz & Bandedge Measurement
RE<1G: Radiated Emission below 1GHz
PLC: Power Line Conducted Emission
APCM: Antenna Port Conducted Measurement

Note: 1. The EUT had been pre-tested on the positioned of each 3 axis. The worst case was found when positioned on **X-plane**

Radiated Emission Test (Above 1GHz):

- Pre-Scan has been conducted to determine the worst-case mode from all possible combinations between available modulations, data rates and antenna ports (if EUT with antenna diversity architecture).
- Following channel(s) was (were) selected for the final test as listed below.

EUT CONFIGURE MODE	MODE	AVAILABLE CHANNEL	TESTED CHANNEL	MODULATION TECHNOLOGY	MODULATION TYPE	DATA RATE (Mbps)
-	802.11b	1 to 11	1, 6, 11	DSSS	DBPSK	1.0
-	802.11g	1 to 11	1, 6, 11	OFDM	BPSK	6.0
-	802.11n (HT20)	1 to 11	1, 6, 11	OFDM	BPSK	6.5
-	802.11n (HT40)	3 to 9	3, 6, 9	OFDM	BPSK	13.5

Radiated Emission Test (Below 1GHz):

- Pre-Scan has been conducted to determine the worst-case mode from all possible combinations between available modulations, data rates and antenna ports (if EUT with antenna diversity architecture).
- Following channel(s) was (were) selected for the final test as listed below.

EUT CONFIGURE MODE	MODE	AVAILABLE CHANNEL	TESTED CHANNEL	MODULATION TECHNOLOGY	MODULATION TYPE	DATA RATE (Mbps)
-	802.11g	1 to 11	6	OFDM	BPSK	6.0

Power Line Conducted Emission Test:

- Pre-Scan has been conducted to determine the worst-case mode from all possible combinations between available modulations, data rates and antenna ports (if EUT with antenna diversity architecture).
- Following channel(s) was (were) selected for the final test as listed below.

EUT CONFIGURE MODE	MODE	AVAILABLE CHANNEL	TESTED CHANNEL	MODULATION TECHNOLOGY	MODULATION TYPE	DATA RATE (Mbps)
-	802.11g	1 to 11	6	OFDM	BPSK	6.0

Antenna Port Conducted Measurement:

- This item includes all test value of each mode, but only includes spectrum plot of worst value of each mode.
- Pre-Scan has been conducted to determine the worst-case mode from all possible combinations between available modulations, data rates and antenna ports (if EUT with antenna diversity architecture).
- Following channel(s) was (were) selected for the final test as listed below.

EUT CONFIGURE MODE	MODE	AVAILABLE CHANNEL	TESTED CHANNEL	MODULATION TECHNOLOGY	MODULATION TYPE	DATA RATE (Mbps)
-	802.11b	1 to 11	1, 6, 11	DSSS	DBPSK	1.0
-	802.11g	1 to 11	1, 6, 11	OFDM	BPSK	6.0
-	802.11n (HT20)	1 to 11	1, 6, 11	OFDM	BPSK	6.5
-	802.11n (HT40)	3 to 9	3, 6, 9	OFDM	BPSK	13.5

Test Condition:

APPLICABLE TO	ENVIRONMENTAL CONDITIONS	INPUT POWER	TESTED BY
RE \geq 1G	18deg. C, 70%RH	120Vac, 60Hz	Nick Hsu
RE $<$ 1G	18deg. C, 70%RH	120Vac, 60Hz	Jones Chang
PLC	20deg. C, 66%RH	120Vac, 60Hz	Jones Chang
APCM	25deg. C, 60%RH	120Vac, 60Hz	Antony Lee

3.3 Duty Cycle of Test Signal

Duty cycle of test signal is $\geq 98\%$, duty factor is not required.
 Duty cycle of test signal is $< 98\%$, duty factor shall be considered.

802.11b: Duty cycle = 100%

802.11g: Duty cycle = $2.017/2.117 = 0.953$

802.11n (HT20): Duty cycle = $1.88/1.962 = 0.958$

802.11n (HT40): Duty cycle = $0.922/1.012 = 0.911$

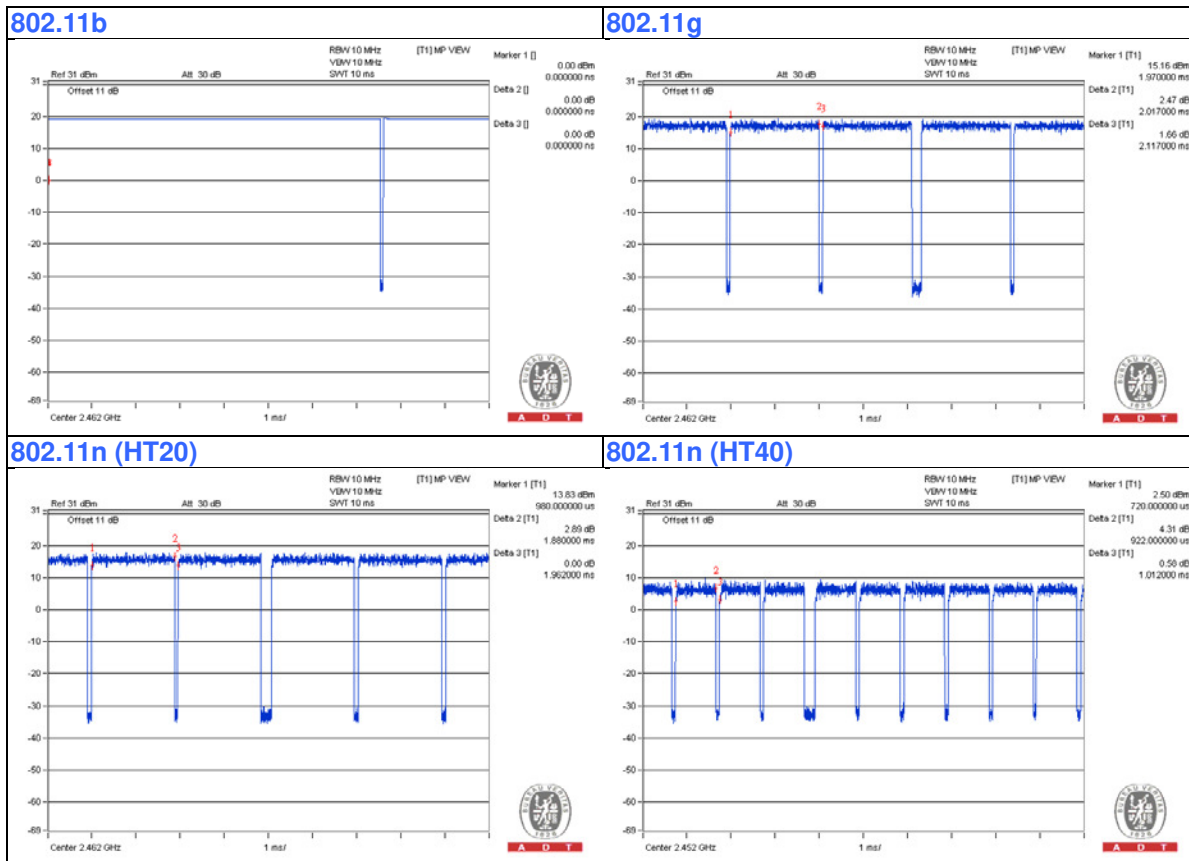

3.4 Description of Support Units

The EUT has been tested as an independent unit together with other necessary accessories or support units. The following support units or accessories were used to form a representative test configuration during the tests.

ID	Product	Brand	Model No.	Serial No.	FCC ID	Remarks
A.	Notebook	DELL	E5410	1HC2XM1	FCC DoC Approved	-
B.	USB 3.0 Hard Disk	WD	WDBACY5000ABL	WX41A81P8576	FCC DoC Approved	-
C.	Load	NA	NA	NA	NA	-

Note:

1. All power cords of the above support units are non-shielded (1.8m).
2. Item A acted as communication partners to transfer data.

ID	Descriptions	Qty.	Length (m)	Shielding (Yes/No)	Cores (Qty.)	Remarks
1.	LAN cable	1	3	N	0	Cat5e
2.	LAN cable	9	1.8	N	0	Cat5e
3.	USB cable	1	0.5	Y	0	-
4.	Console cable	1	1.85	N	0	Accessory of EUT

Note: The core(s) is(are) originally attached to the cable(s).

3.4.1 Configuration of System under Test

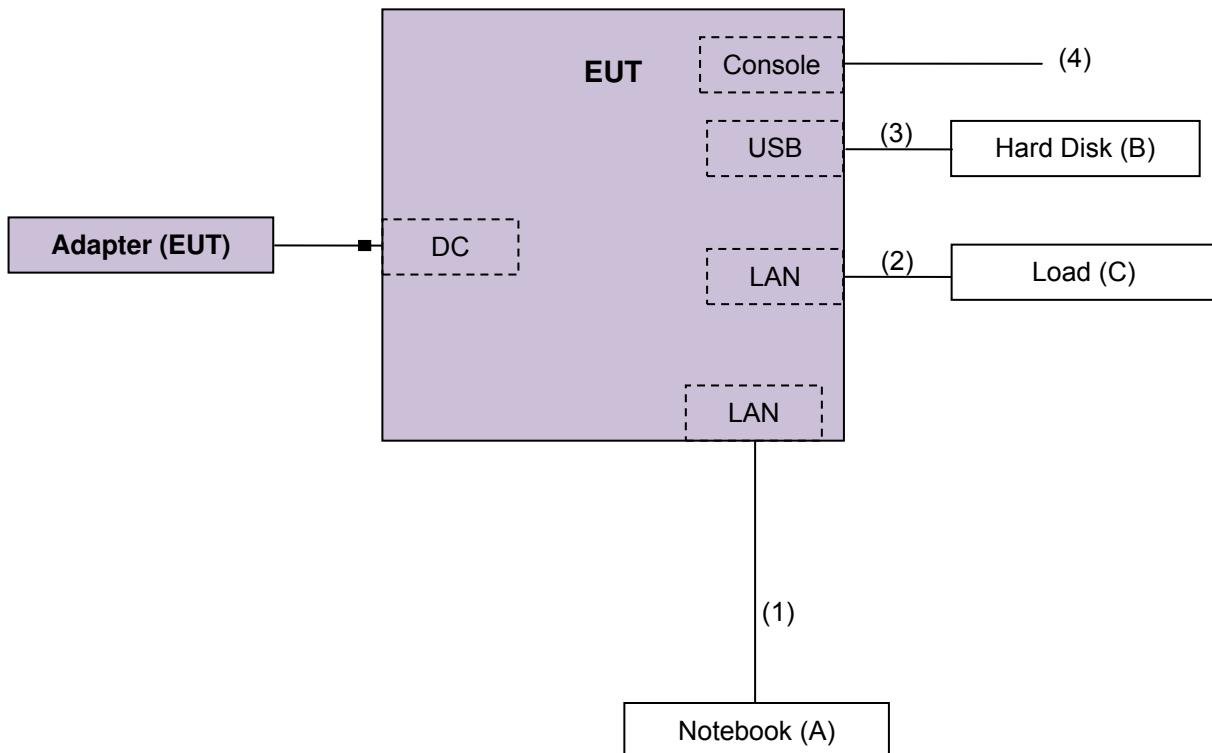

3.5 General Description of Applied Standards

The EUT is a RF Product. According to the specifications of the manufacturer, it must comply with the requirements of the following standards:

FCC Part 15, Subpart C (15.247)
558074 D01 DTS Meas Guidance v03r03
662911 D01 Multiple Transmitter Output v02r01
ANSI C63.10-2013

All test items have been performed and recorded as per the above standards.

NOTE: The EUT has been verified to comply with the requirements of FCC Part 15, Subpart B, Class B (DoC). The test report has been issued separately.

4 Test Types and Results

4.1 Radiated Emission and Bandedge Measurement

4.1.1 Limits of Radiated Emission and Bandedge Measurement

Radiated emissions which fall in the restricted bands must comply with the radiated emission limits specified as below table. Other emissions shall be at least 20dB below the highest level of the desired power:

Frequencies (MHz)	Field Strength (microvolts/meter)	Measurement Distance (meters)
0.009 ~ 0.490	2400/F(kHz)	300
0.490 ~ 1.705	24000/F(kHz)	30
1.705 ~ 30.0	30	30
30 ~ 88	100	3
88 ~ 216	150	3
216 ~ 960	200	3
Above 960	500	3

NOTE:

1. The lower limit shall apply at the transition frequencies.
2. Emission level (dBuV/m) = 20 log Emission level (uV/m).
3. For frequencies above 1000MHz, the field strength limits are based on average detector, however, the peak field strength of any emission shall not exceed the maximum permitted average limits, specified above by more than 20dB under any condition of modulation.

4.1.2 Test Instruments

Description & Manufacturer	Model No.	Serial No.	Cal. Date	Cal. Due
Test Receiver ROHDE & SCHWARZ	ESIB7	100187	Apr. 10, 2015	Apr. 09, 2016
Spectrum Analyzer ROHDE & SCHWARZ	FSP40	100041	Sep. 02, 2015	Sep. 01, 2016
BILOG Antenna SCHWARZBECK	VULB9168	9168-160	Feb. 05, 2015	Feb. 04, 2016
HORN Antenna SCHWARZBECK	9120D	209	Feb. 09, 2015	Feb. 08, 2016
HORN Antenna SCHWARZBECK	BBHA 9170	BBHA9170241	Feb. 09, 2015	Feb. 08, 2016
Preamplifier Agilent	8447D	2944A10738	Oct.18, 2014	Oct. 17, 2015
Preamplifier Agilent	8449B	3008A01964	Aug. 22, 2015	Aug. 21, 2016
RF signal cable HUBER+SUHNNER	SUCOFLEX 104	Cable-CH3-03(214378)	Aug. 22, 2015	Aug. 21, 2016
RF signal cable HUBER+SUHNNER	SUCOFLEX 106	Cable-CH3-03(309224+ 12738)	Aug. 22, 2015	Aug. 21, 2016
Software BV ADT	ADT_Radiated_ V7.6.15.9.4	NA	NA	NA
Antenna Tower inn-co GmbH	MA 4000	013303	NA	NA
Antenna Tower Controller BV ADT	AT100	AT93021702	NA	NA
Turn Table BV ADT	TT100	TT93021702	NA	NA
Turn Table Controller BV ADT	SC100	SC93021702	NA	NA
High Speed Peak Power Meter	ML2495A	0824011	Jul. 09, 2015	Jul. 08, 2016
Power Sensor	MA2411B	0738171	Jul. 09, 2015	Jul. 08, 2016

NOTE: 1. The calibration interval of the above test instruments is 12 months and the calibrations are traceable to NML/ROC and NIST/USA.

2. The test was performed in HwaYa Chamber 3.

3. The horn antenna and HP preamplifier (model: 8449B) are used only for the measurement of emission frequency above 1GHz if tested.

4. The FCC Site Registration No. is 988962.

5. The IC Site Registration No. is IC 7450F-3.

4.1.3 Test Procedures

- a. The EUT was placed on the top of a rotating table 0.8 meters (for below 1GHz) / 1.5 meters (for above 1GHz) above the ground at 3 meter chamber room for test. The table was rotated 360 degrees to determine the position of the highest radiation.
- b. The EUT was set 3 meters away from the interference-receiving antenna, which was mounted on the top of a variable-height antenna tower.
- c. The height of antenna is varied from one meter to four meters above the ground to determine the maximum value of the field strength. Both horizontal and vertical polarizations of the antenna are set to make the measurement.
- d. For each suspected emission, the EUT was arranged to its worst case and then the antenna was tuned to heights from 1 meter to 4 meters and the rotatable table was turned from 0 degrees to 360 degrees to find the maximum reading.
- e. The test-receiver system was set to quasi-peak detect function and specified bandwidth with maximum hold mode when the test frequency is below 1 GHz.
- f. The test-receiver system was set to peak and average detect function and specified bandwidth with maximum hold mode when the test frequency is above 1 GHz. If the peak reading value also meets average limit, measurement with the average detector is unnecessary.

Note:

1. The resolution bandwidth and video bandwidth of test receiver/spectrum analyzer is 120kHz for Quasi-peak detection (QP) at frequency below 1GHz.
2. The resolution bandwidth of test receiver/spectrum analyzer is 1 MHz and the video bandwidth is 3 MHz for Peak detection (PK) at frequency above 1GHz.
3. The resolution bandwidth of test receiver/spectrum analyzer is 1MHz and the video bandwidth is 3MHz for RMS Average (Duty cycle < 98%) for Average detection (AV) at frequency above 1GHz, then the measurement results was added to a correction factor ($10 \log(1/\text{duty cycle})$).
4. The resolution bandwidth of test receiver/spectrum analyzer is 1MHz and the video bandwidth is 10Hz (Duty cycle $\geq 98\%$) for Average detection (AV) at frequency above 1GHz.
5. All modes of operation were investigated and the worst-case emissions are reported.

4.1.4 Deviation from Test Standard

No deviation.

4.1.5 Test Set Up

<Frequency Range below 1GHz>

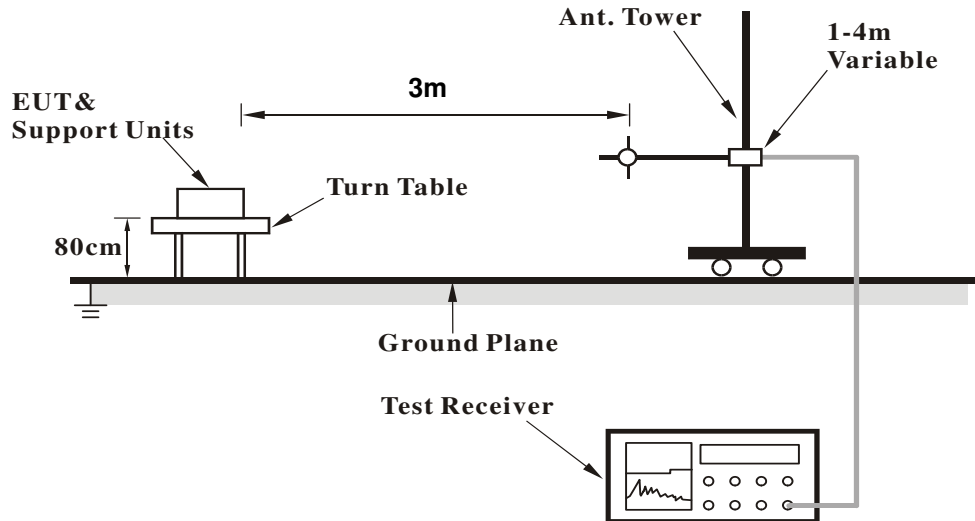

<Frequency Range above 1GHz>

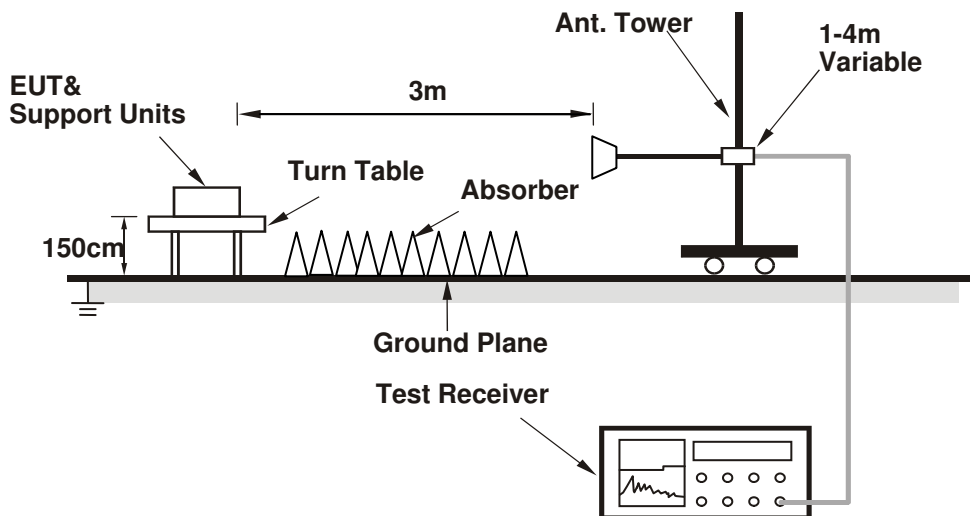

For the actual test configuration, please refer to the attached file (Test Setup Photo).

4.1.6 EUT Operating Conditions

- Placed the EUT on the testing table.
- Prepared notebook to act as communication partner and placed it outside of testing area.
- The communication partner connected with EUT via a RJ45 cable and ran a test program (provided by manufacturer) to enable EUT under transmission condition continuously at specific channel frequency.
- The communication partner sent data to EUT by command "PING".
- The necessary accessories enable the system in full functions.

4.1.7 Test Results

Above 1GHz Data :

802.11b

CHANNEL	TX Channel 1	DETECTOR FUNCTION	Peak (PK)
FREQUENCY RANGE	1GHz ~ 25GHz		Average (AV)

ANTENNA POLARITY & TEST DISTANCE: HORIZONTAL AT 3 M

NO.	FREQ. (MHz)	EMISSION LEVEL (dBuV/m)	LIMIT (dBuV/m)	MARGIN (dB)	ANTENNA HEIGHT (m)	TABLE ANGLE (Degree)	RAW VALUE (dBuV)	CORRECTION FACTOR (dB/m)
1	2390.00	58.4 PK	74.0	-15.6	1.35 H	218	25.90	32.50
2	2390.00	46.9 AV	54.0	-7.1	1.35 H	218	14.40	32.50
3	*2412.00	105.9 PK			1.03 H	32	73.30	32.60
4	*2412.00	103.1 AV			1.03 H	32	70.50	32.60
5	4824.00	47.4 PK	74.0	-26.6	1.02 H	117	41.30	6.10
6	4824.00	36.4 AV	54.0	-17.6	1.02 H	117	30.30	6.10

ANTENNA POLARITY & TEST DISTANCE: VERTICAL AT 3 M

NO.	FREQ. (MHz)	EMISSION LEVEL (dBuV/m)	LIMIT (dBuV/m)	MARGIN (dB)	ANTENNA HEIGHT (m)	TABLE ANGLE (Degree)	RAW VALUE (dBuV)	CORRECTION FACTOR (dB/m)
1	2390.00	59.9 PK	74.0	-14.1	1.53 V	105	27.40	32.50
2	2390.00	52.2 AV	54.0	-1.8	1.53 V	105	19.70	32.50
3	*2412.00	118.0 PK			1.08 V	177	85.40	32.60
4	*2412.00	115.2 AV			1.08 V	177	82.60	32.60
5	4824.00	48.7 PK	74.0	-25.3	1.17 V	253	42.60	6.10
6	4824.00	36.2 AV	54.0	-17.8	1.17 V	253	30.10	6.10

REMARKS:

1. Emission Level(dBuV/m) = Raw Value(dBuV) + Correction Factor(dB/m)
2. Correction Factor(dB/m) = Antenna Factor(dB/m) + Cable Factor(dB)
3. The other emission levels were very low against the limit.
4. Margin value = Emission Level – Limit value
5. " * ": Fundamental frequency.



CHANNEL	TX Channel 6	DETECTOR FUNCTION	Peak (PK)
FREQUENCY RANGE	1GHz ~ 25GHz		Average (AV)

ANTENNA POLARITY & TEST DISTANCE: HORIZONTAL AT 3 M

NO.	FREQ. (MHz)	EMISSION LEVEL (dBuV/m)	LIMIT (dBuV/m)	MARGIN (dB)	ANTENNA HEIGHT (m)	TABLE ANGLE (Degree)	RAW VALUE (dBuV)	CORRECTION FACTOR (dB/m)
1	2390.00	58.6 PK	74.0	-15.4	1.40 H	118	26.10	32.50
2	2390.00	46.7 AV	54.0	-7.3	1.40 H	118	14.20	32.50
3	*2437.00	109.8 PK			1.68 H	194	77.10	32.70
4	*2437.00	107.2 AV			1.68 H	194	74.50	32.70
5	4874.00	48.1 PK	74.0	-25.9	1.32 H	252	41.90	6.20
6	4874.00	36.9 AV	54.0	-17.1	1.32 H	252	30.70	6.20

ANTENNA POLARITY & TEST DISTANCE: VERTICAL AT 3 M

NO.	FREQ. (MHz)	EMISSION LEVEL (dBuV/m)	LIMIT (dBuV/m)	MARGIN (dB)	ANTENNA HEIGHT (m)	TABLE ANGLE (Degree)	RAW VALUE (dBuV)	CORRECTION FACTOR (dB/m)
1	2390.00	60.5 PK	74.0	-13.5	1.43 V	154	28.00	32.50
2	2390.00	52.2 AV	54.0	-1.8	1.43 V	154	19.70	32.50
3	*2437.00	121.8 PK			1.37 V	174	89.10	32.70
4	*2437.00	118.8 AV			1.37 V	174	86.10	32.70
5	4874.00	48.5 PK	74.0	-25.5	1.14 V	69	42.30	6.20
6	4874.00	36.9 AV	54.0	-17.1	1.14 V	69	30.70	6.20

REMARKS:

1. Emission Level(dBuV/m) = Raw Value(dBuV) + Correction Factor(dB/m)
2. Correction Factor(dB/m) = Antenna Factor(dB/m) + Cable Factor(dB)
3. The other emission levels were very low against the limit.
4. Margin value = Emission Level – Limit value
5. " * ": Fundamental frequency.

CHANNEL	TX Channel 11	DETECTOR FUNCTION	Peak (PK)
FREQUENCY RANGE	1GHz ~ 25GHz		Average (AV)

ANTENNA POLARITY & TEST DISTANCE: HORIZONTAL AT 3 M

NO.	FREQ. (MHz)	EMISSION LEVEL (dBuV/m)	LIMIT (dBuV/m)	MARGIN (dB)	ANTENNA HEIGHT (m)	TABLE ANGLE (Degree)	RAW VALUE (dBuV)	CORRECTION FACTOR (dB/m)
1	*2462.00	106.1 PK			1.18 H	125	73.50	32.60
2	*2462.00	103.0 AV			1.18 H	125	70.40	32.60
3	2483.50	59.8 PK	74.0	-14.2	1.29 H	35	27.10	32.70
4	2483.50	46.9 AV	54.0	-7.1	1.29 H	35	14.20	32.70
5	4924.00	48.1 PK	74.0	-25.9	1.26 H	105	41.80	6.30
6	4924.00	37.1 AV	54.0	-16.9	1.26 H	105	30.80	6.30

ANTENNA POLARITY & TEST DISTANCE: VERTICAL AT 3 M

NO.	FREQ. (MHz)	EMISSION LEVEL (dBuV/m)	LIMIT (dBuV/m)	MARGIN (dB)	ANTENNA HEIGHT (m)	TABLE ANGLE (Degree)	RAW VALUE (dBuV)	CORRECTION FACTOR (dB/m)
1	*2462.00	117.3 PK			1.21 V	173	84.70	32.60
2	*2462.00	114.1 AV			1.21 V	173	81.50	32.60
3	2483.50	61.1 PK	74.0	-12.9	1.06 V	166	28.40	32.70
4	2483.50	52.8 AV	54.0	-1.2	1.06 V	166	20.10	32.70
5	4924.00	48.2 PK	74.0	-25.8	1.31 V	79	41.90	6.30
6	4924.00	37.5 AV	54.0	-16.5	1.31 V	79	31.20	6.30

REMARKS:

1. Emission Level(dBuV/m) = Raw Value(dBuV) + Correction Factor(dB/m)
2. Correction Factor(dB/m) = Antenna Factor(dB/m) + Cable Factor(dB)
3. The other emission levels were very low against the limit.
4. Margin value = Emission Level – Limit value
5. " * ": Fundamental frequency.

802.11g

CHANNEL	TX Channel 1	DETECTOR FUNCTION	Peak (PK)
FREQUENCY RANGE	1GHz ~ 25GHz		Average (AV)

ANTENNA POLARITY & TEST DISTANCE: HORIZONTAL AT 3 M

NO.	FREQ. (MHz)	EMISSION LEVEL (dBuV/m)	LIMIT (dBuV/m)	MARGIN (dB)	ANTENNA HEIGHT (m)	TABLE ANGLE (Degree)	RAW VALUE (dBuV)	CORRECTION FACTOR (dB/m)
1	2390.00	58.0 PK	74.0	-16.0	1.06 H	211	25.50	32.50
2	2390.00	47.1 AV	54.0	-6.9	1.06 H	211	14.60	32.50
3	*2412.00	105.5 PK			1.32 H	148	72.90	32.60
4	*2412.00	95.9 AV			1.32 H	148	63.30	32.60
5	4824.00	47.1 PK	74.0	-26.9	1.02 H	89	41.00	6.10
6	4824.00	35.9 AV	54.0	-18.1	1.02 H	89	29.80	6.10

ANTENNA POLARITY & TEST DISTANCE: VERTICAL AT 3 M

NO.	FREQ. (MHz)	EMISSION LEVEL (dBuV/m)	LIMIT (dBuV/m)	MARGIN (dB)	ANTENNA HEIGHT (m)	TABLE ANGLE (Degree)	RAW VALUE (dBuV)	CORRECTION FACTOR (dB/m)
1	2390.00	66.7 PK	74.0	-7.3	1.25 V	184	34.20	32.50
2	2390.00	52.2 AV	54.0	-1.8	1.25 V	184	19.70	32.50
3	*2412.00	115.4 PK			1.10 V	168	82.80	32.60
4	*2412.00	105.8 AV			1.10 V	168	73.20	32.60
5	4824.00	48.0 PK	74.0	-26.0	1.33 V	85	41.90	6.10
6	4824.00	36.2 AV	54.0	-17.8	1.33 V	85	30.10	6.10

REMARKS:

1. Emission Level(dBuV/m) = Raw Value(dBuV) + Correction Factor(dB/m)
2. Correction Factor(dB/m) = Antenna Factor(dB/m) + Cable Factor(dB)
3. The other emission levels were very low against the limit.
4. Margin value = Emission Level – Limit value
5. " * ": Fundamental frequency.



CHANNEL	TX Channel 6	DETECTOR FUNCTION	Peak (PK)
FREQUENCY RANGE	1GHz ~ 25GHz		Average (AV)

ANTENNA POLARITY & TEST DISTANCE: HORIZONTAL AT 3 M

NO.	FREQ. (MHz)	EMISSION LEVEL (dBuV/m)	LIMIT (dBuV/m)	MARGIN (dB)	ANTENNA HEIGHT (m)	TABLE ANGLE (Degree)	RAW VALUE (dBuV)	CORRECTION FACTOR (dB/m)
1	2390.00	58.5 PK	74.0	-15.5	1.10 H	56	26.00	32.50
2	2390.00	47.2 AV	54.0	-6.8	1.10 H	56	14.70	32.50
3	*2437.00	111.7 PK			1.30 H	147	79.00	32.70
4	*2437.00	101.7 AV			1.30 H	147	69.00	32.70
5	4874.00	47.2 PK	74.0	-26.8	1.21 H	136	41.00	6.20
6	4874.00	36.4 AV	54.0	-17.6	1.21 H	136	30.20	6.20

ANTENNA POLARITY & TEST DISTANCE: VERTICAL AT 3 M

NO.	FREQ. (MHz)	EMISSION LEVEL (dBuV/m)	LIMIT (dBuV/m)	MARGIN (dB)	ANTENNA HEIGHT (m)	TABLE ANGLE (Degree)	RAW VALUE (dBuV)	CORRECTION FACTOR (dB/m)
1	2390.00	68.6 PK	74.0	-5.4	1.28 V	181	36.10	32.50
2	2390.00	52.2 AV	54.0	-1.8	1.28 V	181	19.70	32.50
3	*2437.00	122.0 PK			1.21 V	179	89.30	32.70
4	*2437.00	112.4 AV			1.21 V	179	79.70	32.70
5	4874.00	48.0 PK	74.0	-26.0	1.10 V	122	41.80	6.20
6	4874.00	36.6 AV	54.0	-17.4	1.10 V	122	30.40	6.20

REMARKS:

1. Emission Level(dBuV/m) = Raw Value(dBuV) + Correction Factor(dB/m)
2. Correction Factor(dB/m) = Antenna Factor(dB/m) + Cable Factor(dB)
3. The other emission levels were very low against the limit.
4. Margin value = Emission Level – Limit value
5. " * ": Fundamental frequency.

CHANNEL	TX Channel 11	DETECTOR FUNCTION	Peak (PK)
FREQUENCY RANGE	1GHz ~ 25GHz		Average (AV)

ANTENNA POLARITY & TEST DISTANCE: HORIZONTAL AT 3 M

NO.	FREQ. (MHz)	EMISSION LEVEL (dBuV/m)	LIMIT (dBuV/m)	MARGIN (dB)	ANTENNA HEIGHT (m)	TABLE ANGLE (Degree)	RAW VALUE (dBuV)	CORRECTION FACTOR (dB/m)
1	*2462.00	105.4 PK			1.00 H	147	72.80	32.60
2	*2462.00	95.6 AV			1.00 H	147	63.00	32.60
3	2483.50	58.8 PK	74.0	-15.2	1.01 H	217	26.10	32.70
4	2483.50	47.2 AV	54.0	-6.8	1.01 H	217	14.50	32.70
5	4924.00	48.1 PK	74.0	-25.9	1.08 H	222	41.80	6.30
6	4924.00	36.6 AV	54.0	-17.4	1.08 H	222	30.30	6.30

ANTENNA POLARITY & TEST DISTANCE: VERTICAL AT 3 M

NO.	FREQ. (MHz)	EMISSION LEVEL (dBuV/m)	LIMIT (dBuV/m)	MARGIN (dB)	ANTENNA HEIGHT (m)	TABLE ANGLE (Degree)	RAW VALUE (dBuV)	CORRECTION FACTOR (dB/m)
1	*2462.00	117.1 PK			1.36 V	180	84.50	32.60
2	*2462.00	107.5 AV			1.36 V	180	74.90	32.60
3	2483.50	66.6 PK	74.0	-7.4	1.04 V	98	33.90	32.70
4	2483.50	52.2 AV	54.0	-1.8	1.04 V	98	19.50	32.70
5	4924.00	47.8 PK	74.0	-26.2	1.18 V	102	41.50	6.30
6	4924.00	36.8 AV	54.0	-17.2	1.18 V	102	30.50	6.30

REMARKS:

1. Emission Level(dBuV/m) = Raw Value(dBuV) + Correction Factor(dB/m)
2. Correction Factor(dB/m) = Antenna Factor(dB/m) + Cable Factor(dB)
3. The other emission levels were very low against the limit.
4. Margin value = Emission Level – Limit value
5. " * ": Fundamental frequency.

802.11n (HT20)

CHANNEL	TX Channel 1	DETECTOR FUNCTION	Peak (PK)
FREQUENCY RANGE	1GHz ~ 25GHz		Average (AV)

ANTENNA POLARITY & TEST DISTANCE: HORIZONTAL AT 3 M

NO.	FREQ. (MHz)	EMISSION LEVEL (dBuV/m)	LIMIT (dBuV/m)	MARGIN (dB)	ANTENNA HEIGHT (m)	TABLE ANGLE (Degree)	RAW VALUE (dBuV)	CORRECTION FACTOR (dB/m)
1	2390.00	57.8 PK	74.0	-16.2	1.11 H	183	25.30	32.50
2	2390.00	47.4 AV	54.0	-6.6	1.11 H	183	14.90	32.50
3	*2412.00	104.8 PK			1.03 H	196	72.20	32.60
4	*2412.00	94.7 AV			1.03 H	196	62.10	32.60
5	4824.00	48.6 PK	74.0	-25.4	1.00 H	98	42.50	6.10
6	4824.00	35.8 AV	54.0	-18.2	1.00 H	98	29.70	6.10

ANTENNA POLARITY & TEST DISTANCE: VERTICAL AT 3 M

NO.	FREQ. (MHz)	EMISSION LEVEL (dBuV/m)	LIMIT (dBuV/m)	MARGIN (dB)	ANTENNA HEIGHT (m)	TABLE ANGLE (Degree)	RAW VALUE (dBuV)	CORRECTION FACTOR (dB/m)
1	2390.00	70.7 PK	74.0	-3.3	1.24 V	165	38.20	32.50
2	2390.00	53.0 AV	54.0	-1.0	1.24 V	165	20.50	32.50
3	*2412.00	114.8 PK			1.11 V	163	82.20	32.60
4	*2412.00	104.5 AV			1.11 V	163	71.90	32.60
5	4824.00	49.4 PK	74.0	-24.6	1.40 V	89	43.30	6.10
6	4824.00	36.4 AV	54.0	-17.6	1.40 V	89	30.30	6.10

REMARKS:

1. Emission Level(dBuV/m) = Raw Value(dBuV) + Correction Factor(dB/m)
2. Correction Factor(dB/m) = Antenna Factor(dB/m) + Cable Factor(dB)
3. The other emission levels were very low against the limit.
4. Margin value = Emission Level – Limit value
5. " * ": Fundamental frequency.

CHANNEL	TX Channel 6	DETECTOR FUNCTION	Peak (PK)
FREQUENCY RANGE	1GHz ~ 25GHz		Average (AV)

ANTENNA POLARITY & TEST DISTANCE: HORIZONTAL AT 3 M

NO.	FREQ. (MHz)	EMISSION LEVEL (dBuV/m)	LIMIT (dBuV/m)	MARGIN (dB)	ANTENNA HEIGHT (m)	TABLE ANGLE (Degree)	RAW VALUE (dBuV)	CORRECTION FACTOR (dB/m)
1	2390.00	58.9 PK	74.0	-15.1	1.19 H	197	26.40	32.50
2	2390.00	48.0 AV	54.0	-6.0	1.19 H	197	15.50	32.50
3	*2437.00	109.5 PK			1.16 H	283	76.80	32.70
4	*2437.00	100.3 AV			1.16 H	283	67.60	32.70
5	4874.00	49.0 PK	74.0	-25.0	1.23 H	190	42.80	6.20
6	4874.00	36.2 AV	54.0	-17.8	1.23 H	190	30.00	6.20

ANTENNA POLARITY & TEST DISTANCE: VERTICAL AT 3 M

NO.	FREQ. (MHz)	EMISSION LEVEL (dBuV/m)	LIMIT (dBuV/m)	MARGIN (dB)	ANTENNA HEIGHT (m)	TABLE ANGLE (Degree)	RAW VALUE (dBuV)	CORRECTION FACTOR (dB/m)
1	2390.00	68.6 PK	74.0	-5.4	1.26 V	190	36.10	32.50
2	2390.00	52.1 AV	54.0	-1.9	1.26 V	190	19.60	32.50
3	*2437.00	121.6 PK			1.39 V	160	88.90	32.70
4	*2437.00	111.6 AV			1.39 V	160	78.90	32.70
5	4874.00	50.0 PK	74.0	-24.0	1.41 V	268	43.80	6.20
6	4874.00	37.2 AV	54.0	-16.8	1.41 V	268	31.00	6.20

REMARKS:

1. Emission Level(dBuV/m) = Raw Value(dBuV) + Correction Factor(dB/m)
2. Correction Factor(dB/m) = Antenna Factor(dB/m) + Cable Factor(dB)
3. The other emission levels were very low against the limit.
4. Margin value = Emission Level – Limit value
5. " * ": Fundamental frequency.

CHANNEL	TX Channel 11	DETECTOR FUNCTION	Peak (PK)
FREQUENCY RANGE	1GHz ~ 25GHz		Average (AV)

ANTENNA POLARITY & TEST DISTANCE: HORIZONTAL AT 3 M

NO.	FREQ. (MHz)	EMISSION LEVEL (dBuV/m)	LIMIT (dBuV/m)	MARGIN (dB)	ANTENNA HEIGHT (m)	TABLE ANGLE (Degree)	RAW VALUE (dBuV)	CORRECTION FACTOR (dB/m)
1	*2462.00	104.3 PK			1.18 H	137	71.70	32.60
2	*2462.00	94.5 AV			1.18 H	137	61.90	32.60
3	2483.50	57.7 PK	74.0	-16.3	1.09 H	186	25.00	32.70
4	2483.50	47.2 AV	54.0	-6.8	1.09 H	186	14.50	32.70
5	4924.00	48.9 PK	74.0	-25.1	1.03 H	140	42.60	6.30
6	4924.00	36.0 AV	54.0	-18.0	1.03 H	140	29.70	6.30

ANTENNA POLARITY & TEST DISTANCE: VERTICAL AT 3 M

NO.	FREQ. (MHz)	EMISSION LEVEL (dBuV/m)	LIMIT (dBuV/m)	MARGIN (dB)	ANTENNA HEIGHT (m)	TABLE ANGLE (Degree)	RAW VALUE (dBuV)	CORRECTION FACTOR (dB/m)
1	*2462.00	114.8 PK			1.35 V	185	82.20	32.60
2	*2462.00	105.2 AV			1.35 V	185	72.60	32.60
3	2483.50	68.4 PK	74.0	-5.6	1.22 V	187	35.70	32.70
4	2483.50	52.7 AV	54.0	-1.3	1.22 V	187	20.00	32.70
5	4924.00	49.2 PK	74.0	-24.8	1.10 V	233	42.90	6.30
6	4924.00	36.3 AV	54.0	-17.7	1.10 V	233	30.00	6.30

REMARKS:

1. Emission Level(dBuV/m) = Raw Value(dBuV) + Correction Factor(dB/m)
2. Correction Factor(dB/m) = Antenna Factor(dB/m) + Cable Factor(dB)
3. The other emission levels were very low against the limit.
4. Margin value = Emission Level – Limit value
5. " * ": Fundamental frequency.

802.11n (HT40)

CHANNEL	TX Channel 3	DETECTOR FUNCTION	Peak (PK)
FREQUENCY RANGE	1GHz ~ 25GHz		Average (AV)

ANTENNA POLARITY & TEST DISTANCE: HORIZONTAL AT 3 M

NO.	FREQ. (MHz)	EMISSION LEVEL (dBuV/m)	LIMIT (dBuV/m)	MARGIN (dB)	ANTENNA HEIGHT (m)	TABLE ANGLE (Degree)	RAW VALUE (dBuV)	CORRECTION FACTOR (dB/m)
1	2390.00	58.5 PK	74.0	-15.5	1.13 H	176	26.00	32.50
2	2390.00	48.0 AV	54.0	-6.0	1.13 H	176	15.50	32.50
3	*2422.00	96.9 PK			1.34 H	144	64.30	32.60
4	*2422.00	87.8 AV			1.34 H	144	55.20	32.60
5	4844.00	48.7 PK	74.0	-25.3	1.21 H	179	42.60	6.10
6	4844.00	35.8 AV	54.0	-18.2	1.21 H	179	29.70	6.10

ANTENNA POLARITY & TEST DISTANCE: VERTICAL AT 3 M

NO.	FREQ. (MHz)	EMISSION LEVEL (dBuV/m)	LIMIT (dBuV/m)	MARGIN (dB)	ANTENNA HEIGHT (m)	TABLE ANGLE (Degree)	RAW VALUE (dBuV)	CORRECTION FACTOR (dB/m)
1	2390.00	66.2 PK	74.0	-7.8	1.26 V	164	33.70	32.50
2	2390.00	53.0 AV	54.0	-1.0	1.26 V	164	20.50	32.50
3	*2422.00	107.8 PK			1.38 V	174	75.20	32.60
4	*2422.00	98.2 AV			1.38 V	174	65.60	32.60
5	4844.00	49.1 PK	74.0	-24.9	1.42 V	123	43.00	6.10
6	4844.00	36.6 AV	54.0	-17.4	1.42 V	123	30.50	6.10

REMARKS:

1. Emission Level(dBuV/m) = Raw Value(dBuV) + Correction Factor(dB/m)
2. Correction Factor(dB/m) = Antenna Factor(dB/m) + Cable Factor(dB)
3. The other emission levels were very low against the limit.
4. Margin value = Emission Level – Limit value
5. " * ": Fundamental frequency.
6. " # ": The radiated frequency is out of the restricted band.

CHANNEL	TX Channel 6	DETECTOR FUNCTION	Peak (PK)
FREQUENCY RANGE	1GHz ~ 25GHz		Average (AV)

ANTENNA POLARITY & TEST DISTANCE: HORIZONTAL AT 3 M

NO.	FREQ. (MHz)	EMISSION LEVEL (dBuV/m)	LIMIT (dBuV/m)	MARGIN (dB)	ANTENNA HEIGHT (m)	TABLE ANGLE (Degree)	RAW VALUE (dBuV)	CORRECTION FACTOR (dB/m)
1	2390.00	57.6 PK	74.0	-16.4	1.20 H	178	25.10	32.50
2	2390.00	47.5 AV	54.0	-6.5	1.20 H	178	15.00	32.50
3	*2437.00	100.0 PK			1.18 H	162	67.30	32.70
4	*2437.00	90.0 AV			1.18 H	162	57.30	32.70
5	4874.00	47.9 PK	74.0	-26.1	1.29 H	196	41.70	6.20
6	4874.00	35.3 AV	54.0	-18.7	1.29 H	196	29.10	6.20

ANTENNA POLARITY & TEST DISTANCE: VERTICAL AT 3 M

NO.	FREQ. (MHz)	EMISSION LEVEL (dBuV/m)	LIMIT (dBuV/m)	MARGIN (dB)	ANTENNA HEIGHT (m)	TABLE ANGLE (Degree)	RAW VALUE (dBuV)	CORRECTION FACTOR (dB/m)
1	2390.00	66.9 PK	74.0	-7.1	1.40 V	165	34.40	32.50
2	2390.00	52.3 AV	54.0	-1.7	1.40 V	165	19.80	32.50
3	*2437.00	113.7 PK			1.08 V	174	81.00	32.70
4	*2437.00	104.3 AV			1.08 V	174	71.60	32.70
5	4874.00	48.4 PK	74.0	-25.6	1.45 V	191	42.20	6.20
6	4874.00	35.7 AV	54.0	-18.3	1.45 V	191	29.50	6.20

REMARKS:

1. Emission Level(dBuV/m) = Raw Value(dBuV) + Correction Factor(dB/m)
2. Correction Factor(dB/m) = Antenna Factor(dB/m) + Cable Factor(dB)
3. The other emission levels were very low against the limit.
4. Margin value = Emission Level – Limit value
5. " * ": Fundamental frequency.

CHANNEL	TX Channel 9	DETECTOR FUNCTION	Peak (PK)
FREQUENCY RANGE	1GHz ~ 25GHz		Average (AV)

ANTENNA POLARITY & TEST DISTANCE: HORIZONTAL AT 3 M

NO.	FREQ. (MHz)	EMISSION LEVEL (dBuV/m)	LIMIT (dBuV/m)	MARGIN (dB)	ANTENNA HEIGHT (m)	TABLE ANGLE (Degree)	RAW VALUE (dBuV)	CORRECTION FACTOR (dB/m)
1	*2452.00	97.3 PK			1.49 H	151	64.70	32.60
2	*2452.00	87.5 AV			1.49 H	151	54.90	32.60
3	2483.50	57.9 PK	74.0	-16.1	1.17 H	150	25.20	32.70
4	2483.50	47.0 AV	54.0	-7.0	1.17 H	150	14.30	32.70
5	4904.00	48.1 PK	74.0	-25.9	1.07 H	201	42.00	6.10
6	4904.00	35.4 AV	54.0	-18.6	1.07 H	201	29.30	6.10

ANTENNA POLARITY & TEST DISTANCE: VERTICAL AT 3 M

NO.	FREQ. (MHz)	EMISSION LEVEL (dBuV/m)	LIMIT (dBuV/m)	MARGIN (dB)	ANTENNA HEIGHT (m)	TABLE ANGLE (Degree)	RAW VALUE (dBuV)	CORRECTION FACTOR (dB/m)
1	*2452.00	106.7 PK			1.23 V	163	74.00	32.70
2	*2452.00	96.8 AV			1.23 V	163	64.10	32.70
3	2483.50	70.8 PK	74.0	-3.2	1.20 V	165	38.10	32.70
4	2483.50	53.0 AV	54.0	-1.0	1.20 V	165	20.30	32.70
5	4904.00	48.5 PK	74.0	-25.5	1.36 V	181	42.40	6.10
6	4904.00	35.9 AV	54.0	-18.1	1.36 V	181	29.80	6.10

REMARKS:

1. Emission Level(dBuV/m) = Raw Value(dBuV) + Correction Factor(dB/m)
2. Correction Factor(dB/m) = Antenna Factor(dB/m) + Cable Factor(dB)
3. The other emission levels were very low against the limit.
4. Margin value = Emission Level – Limit value
5. " * ": Fundamental frequency.

Below 1GHz Data:

802.11g

CHANNEL	TX Channel 6	DETECTOR FUNCTION	Quasi-Peak (QP)
FREQUENCY RANGE	30MHz ~ 1GHz		

ANTENNA POLARITY & TEST DISTANCE: HORIZONTAL AT 3 M

NO.	FREQ. (MHz)	EMISSION LEVEL (dBuV/m)	LIMIT (dBuV/m)	MARGIN (dB)	ANTENNA HEIGHT (m)	TABLE ANGLE (Degree)	RAW VALUE (dBuV)	CORRECTION FACTOR (dB/m)
1	82.40	34.5 QP	40.0	-5.5	1.99 H	95	53.60	-19.10
2	167.94	38.4 QP	43.5	-5.1	1.49 H	252	52.70	-14.30
3	212.66	39.7 QP	43.5	-3.8	1.00 H	246	56.40	-16.70
4	283.96	43.0 QP	46.0	-3.0	1.00 H	325	55.90	-12.90
5	297.14	41.3 QP	46.0	-4.7	1.00 H	47	53.80	-12.50
6	374.04	42.6 QP	46.0	-3.4	1.00 H	159	53.60	-11.00
7	747.34	39.8 QP	46.0	-6.2	1.99 H	12	43.00	-3.20

ANTENNA POLARITY & TEST DISTANCE: VERTICAL AT 3 M

NO.	FREQ. (MHz)	EMISSION LEVEL (dBuV/m)	LIMIT (dBuV/m)	MARGIN (dB)	ANTENNA HEIGHT (m)	TABLE ANGLE (Degree)	RAW VALUE (dBuV)	CORRECTION FACTOR (dB/m)
1	49.34	35.9 QP	40.0	-4.1	1.00 V	1	50.50	-14.60
2	125.17	35.0 QP	43.5	-8.5	1.00 V	314	50.90	-15.90
3	298.21	34.8 QP	46.0	-11.2	1.50 V	228	47.30	-12.50
4	430.42	38.0 QP	46.0	-8.0	1.50 V	16	47.60	-9.60
5	500.42	33.7 QP	46.0	-12.3	1.00 V	267	42.00	-8.30
6	624.85	36.6 QP	46.0	-9.4	1.50 V	178	42.00	-5.40

REMARKS:

1. Emission Level(dBuV/m) = Raw Value(dBuV) + Correction Factor(dB/m)
2. Correction Factor(dB/m) = Antenna Factor(dB/m) + Cable Factor(dB)
3. The other emission levels were very low against the limit.
4. Margin value = Emission Level – Limit value

4.2 Conducted Emission Measurement

4.2.1 Limits of Conducted Emission Measurement

Frequency (MHz)	Conducted Limit (dBuV)	
	Quasi-peak	Average
0.15 - 0.5	66 - 56	56 - 46
0.50 - 5.0	56	46
5.0 - 30.0	60	50

Note: 1. The lower limit shall apply at the transition frequencies.

2. The limit decreases in line with the logarithm of the frequency in the range of 0.15 to 0.50MHz.

4.2.2 Test Instruments

Description & Manufacturer	Model No.	Serial No.	Date Of Calibration	Due Date Of Calibration
Test Receiver ROHDE & SCHWARZ	ESCS 30	100288	Apr. 27, 2015	Apr. 26, 2016
RF signal cable (with 10dB PAD) Woken	5D-FB	Cable-cond2-01	Dec. 26, 2014	Dec. 25, 2015
LISN ROHDE & SCHWARZ (EUT)	ESH2-Z5	100100	Dec. 30, 2014	Dec. 29, 2015
LISN ROHDE & SCHWARZ (Peripheral)	ESH3-Z5	100312	Jul. 21, 2015	Jul. 20, 2016
Software ADT	BV ADT_Cond_ V7.3.7.3	NA	NA	NA

Notes: 1. The calibration interval of the above test instruments is 12 months and the calibrations are traceable to NML/ROC and NIST/USA.

2. The test was performed in HwaYa Shielded Room 2.

3. The VCCI Site Registration No. is C-2047.

4.2.3 Test Procedures

- The EUT was placed 0.4 meters from the conducting wall of the shielded room with EUT being connected to the power mains through a line impedance stabilization network (LISN). Other support units were connected to the power mains through another LISN. The two LISNs provide 50 ohm/ 50uH of coupling impedance for the measuring instrument.
- Both lines of the power mains connected to the EUT were checked for maximum conducted interference.
- The frequency range from 150kHz to 30MHz was searched. Emission levels under (Limit - 20dB) was not recorded.

NOTE: The resolution bandwidth and video bandwidth of test receiver is 9kHz for quasi-peak detection (QP) and average detection (AV) at frequency 0.15MHz-30MHz.

4.2.4 Deviation from Test Standard

No deviation.

4.2.5 Test Setup

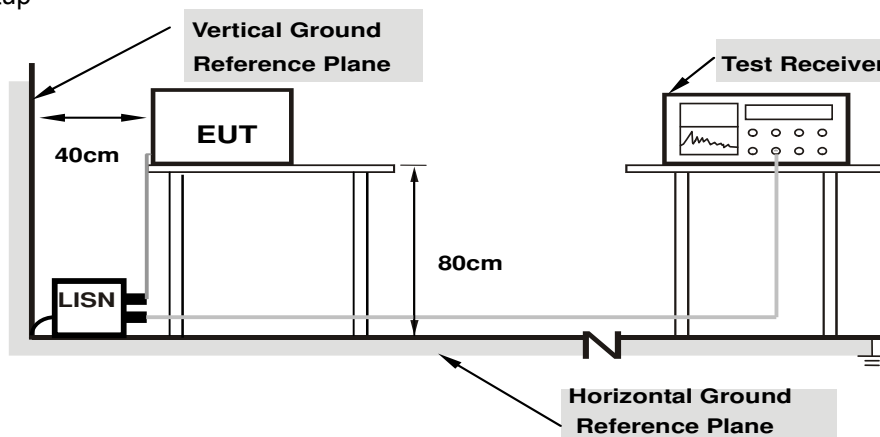

Note: 1.Support units were connected to second LISN.

For the actual test configuration, please refer to the attached file (Test Setup Photo).

4.2.6 EUT Operating Conditions

Same as 4.1.6.

4.2.7 Test Results

802.11g

Phase	Line (L)	Detector Function	Quasi-Peak (QP) / Average (AV)
-------	----------	-------------------	--------------------------------

No	Freq. [MHz]	Corr. Factor (dB)	Reading Value [dB (uV)]		Emission Level [dB (uV)]		Limit [dB (uV)]		Margin (dB)	
			Q.P.	AV.	Q.P.	AV.	Q.P.	AV.	Q.P.	AV.
			1	0.17734	0.20	37.67	25.63	37.87	25.83	64.61
2	0.23594	0.20	33.47	20.76	33.67	20.96	62.24	52.24	-28.57	-31.28
3	0.41563	0.20	32.63	20.07	32.83	20.27	57.54	47.54	-24.70	-27.26
4	0.50938	0.22	33.75	22.67	33.97	22.89	56.00	46.00	-22.03	-23.11
5	0.83750	0.27	27.91	18.17	28.18	18.44	56.00	46.00	-27.82	-27.56
6	14.81250	0.58	12.40	5.53	12.98	6.11	60.00	50.00	-47.02	-43.89

REMARKS:

1. Q.P. and AV. are abbreviations of quasi-peak and average individually.
2. The emission levels of other frequencies were very low against the limit.
3. Margin value = Emission level - Limit value
4. Correction factor = Insertion loss + Cable loss
5. Emission Level = Correction Factor + Reading Value.

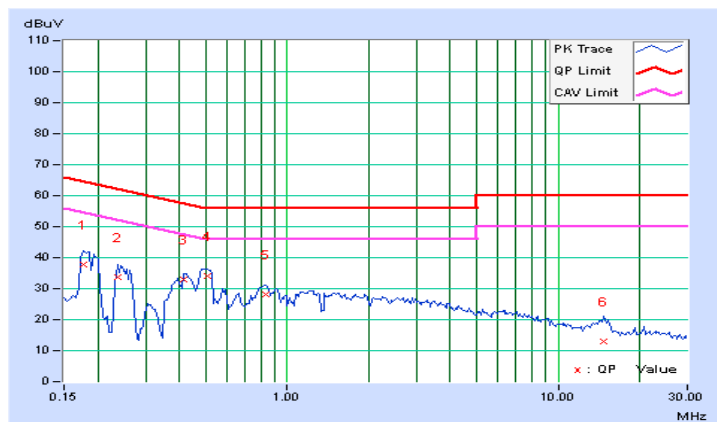

Phase	Neutral (N)	Detector Function	Quasi-Peak (QP) / Average (AV)
-------	-------------	-------------------	--------------------------------

No	Freq. [MHz]	Corr. Factor (dB)	Reading Value [dB (uV)]		Emission Level [dB (uV)]		Limit [dB (uV)]		Margin (dB)	
			Q.P.	AV.	Q.P.	AV.	Q.P.	AV.	Q.P.	AV.
			1	0.18516	0.22	36.69	27.86	36.91	28.08	64.25
2	0.23594	0.23	32.62	19.43	32.85	19.66	62.24	52.24	-29.39	-32.58
3	0.41953	0.25	33.83	23.29	34.08	23.54	57.46	47.46	-23.38	-23.92
4	0.49375	0.26	34.78	23.97	35.04	24.23	56.10	46.10	-21.07	-21.88
5	0.84531	0.29	26.17	15.31	26.46	15.60	56.00	46.00	-29.54	-30.40
6	1.28906	0.34	22.83	11.20	23.17	11.54	56.00	46.00	-32.83	-34.46

REMARKS:

1. Q.P. and AV. are abbreviations of quasi-peak and average individually.
2. The emission levels of other frequencies were very low against the limit.
3. Margin value = Emission level - Limit value
4. Correction factor = Insertion loss + Cable loss
5. Emission Level = Correction Factor + Reading Value.

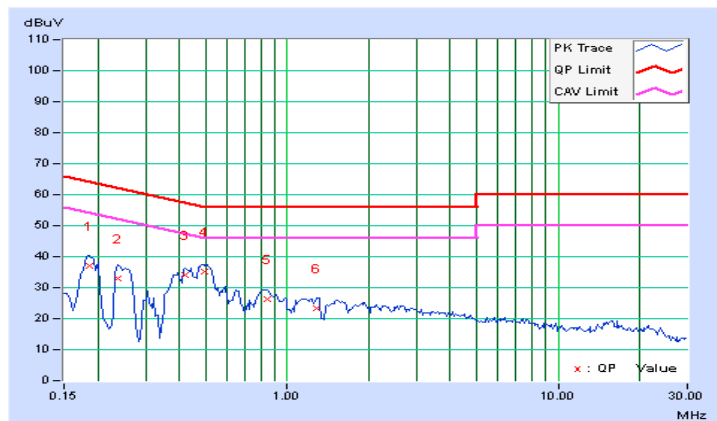

4.3 6dB Bandwidth Measurement

4.3.1 Limits of 6dB Bandwidth Measurement

The minimum of 6dB Bandwidth Measurement is 0.5 MHz.

4.3.2 Test Setup

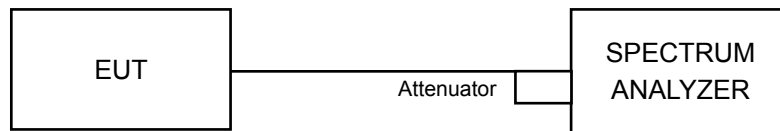

4.3.3 Test Instruments

Refer to section 4.1.2 to get information of above instrument.

4.3.4 Test Procedure

- a. Set resolution bandwidth (RBW) = 100kHz
- b. Set the video bandwidth (VBW) $\geq 3 \times$ RBW, Detector = Peak.
- c. Trace mode = max hold.
- d. Sweep = auto couple.
- e. Measure the maximum width of the emission that is constrained by the frequencies associated with the two amplitude points (upper and lower) that are attenuated by 6 dB relative to the maximum level measured in the fundamental emission

4.3.5 Deviation from Test Standard

No deviation.

4.3.6 EUT Operating Conditions

The software provided by client to enable the EUT under transmission condition continuously at lowest, middle and highest channel frequencies individually.

4.3.7 Test Result

802.11b

Channel	Frequency (MHz)	6dB Bandwidth (MHz)			Minimum Limit (MHz)	Pass / Fail
		CHAIN 0	CHAIN 1	CHAIN 2		
1	2412	10.10	10.10	10.11	0.5	PASS
6	2437	10.11	10.13	10.12	0.5	PASS
11	2462	10.12	10.11	10.12	0.5	PASS

802.11g

Channel	Frequency (MHz)	6dB Bandwidth (MHz)			Minimum Limit (MHz)	Pass / Fail
		CHAIN 0	CHAIN 1	CHAIN 2		
1	2412	16.37	16.37	16.37	0.5	PASS
6	2437	16.37	16.36	16.35	0.5	PASS
11	2462	16.39	16.36	16.36	0.5	PASS

802.11n (HT20)

Channel	Frequency (MHz)	6dB Bandwidth (MHz)			Minimum Limit (MHz)	Pass / Fail
		CHAIN 0	CHAIN 1	CHAIN 2		
1	2412	17.34	16.98	16.98	0.5	PASS
6	2437	17.35	16.93	16.69	0.5	PASS
11	2462	17.56	17.32	17.33	0.5	PASS

802.11n (HT40)

Channel	Frequency (MHz)	6dB Bandwidth (MHz)			Minimum Limit (MHz)	Pass / Fail
		CHAIN 0	CHAIN 1	CHAIN 2		
3	2422	35.87	35.83	35.83	0.5	PASS
6	2437	35.83	35.82	35.82	0.5	PASS
9	2452	36.12	35.84	35.82	0.5	PASS

Spectrum Plot of Worst Value

802.11b

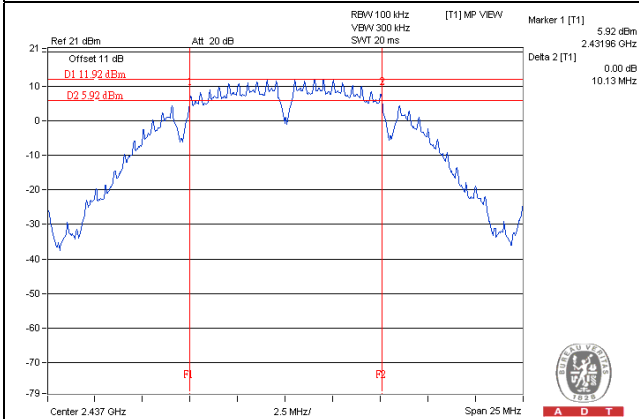

802.11g

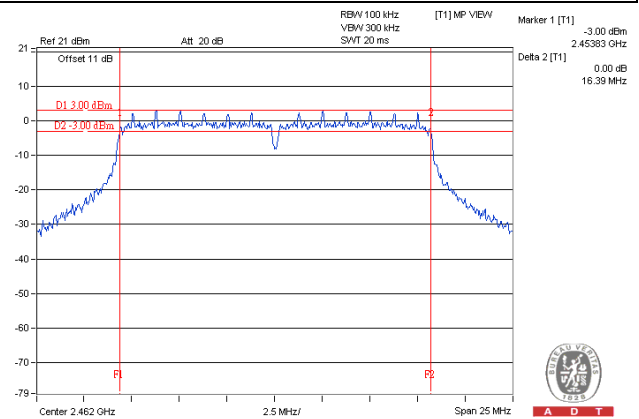

802.11n (HT20)

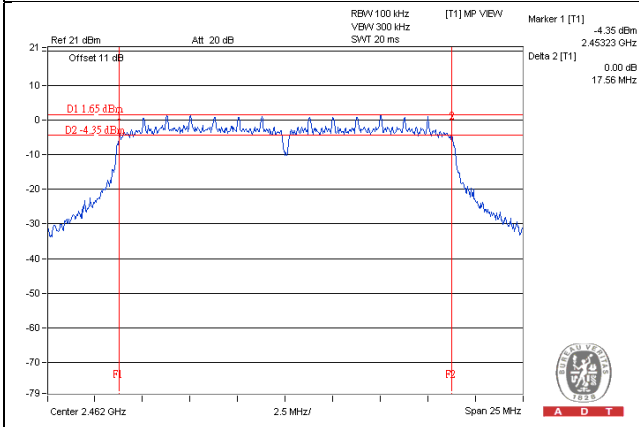

802.11n (HT40)

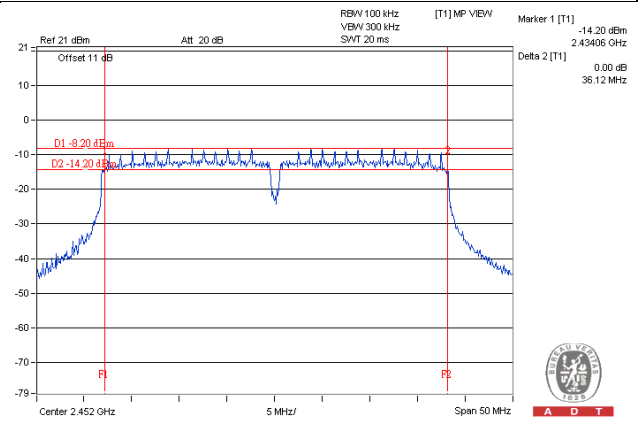

4.4 Conducted Output Power Measurement

4.4.1 Limits of Conducted Output Power Measurement

For systems using digital modulation in the 2400–2483.5 MHz bands: 1 Watt (30dBm)

Per KDB 662911 D01 Multiple Transmitter Output Method of conducted output power measurement on IEEE 802.11 devices,

Array Gain = 0 dB (i.e., no array gain) for $NANT \leq 4$;

Array Gain = 0 dB (i.e., no array gain) for channel widths ≥ 40 MHz for any NANT;

Array Gain = $5 \log(NANT/NSS)$ dB or 3 dB, whichever is less for 20-MHz channel widths with $NANT \geq 5$.

For power measurements on all other devices: Array Gain = $10 \log(NANT/NSS)$ dB.

4.4.2 Test Setup

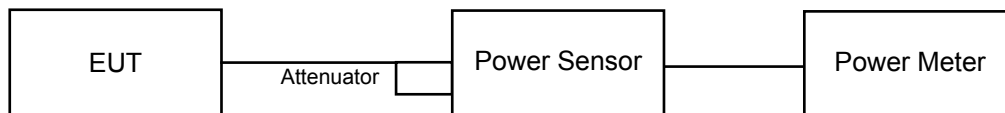

4.4.3 Test Instruments

Refer to section 4.1.2 to get information of above instrument.

4.4.4 Test Procedures

A peak / average power sensor was used on the output port of the EUT. A power meter was used to read the response of the peak / average power sensor. Record the power level.

4.4.5 Deviation from Test Standard

No deviation.

4.4.6 EUT Operating Conditions

Same as Item 4.3.6.

4.4.7 Test Results

FOR PEAK POWER

802.11b

Chan.	Freq. (MHz)	Peak Power (dBm)			Total Power (mW)	Total Power (dBm)	Limit (dBm)	Pass / Fail
		Chain 0	Chain 1	Chain 2				
1	2412	20.38	20.25	19.70	308.394	24.89	30	Pass
6	2437	23.11	22.92	22.30	570.352	27.56	30	Pass
11	2462	20.24	20.19	19.41	297.451	24.73	30	Pass

802.11g

Chan.	Freq. (MHz)	Peak Power (dBm)			Total Power (mW)	Total Power (dBm)	Limit (dBm)	Pass / Fail
		Chain 0	Chain 1	Chain 2				
1	2412	19.75	19.62	19.31	271.338	24.34	30	Pass
6	2437	24.15	23.94	23.48	730.602	28.64	30	Pass
11	2462	20.17	20.22	19.53	298.931	24.76	30	Pass

802.11n (HT20)

Chan.	Freq. (MHz)	Peak Power (dBm)			Total Power (mW)	Total Power (dBm)	Limit (dBm)	Pass / Fail
		Chain 0	Chain 1	Chain 2				
1	2412	19.09	18.71	18.19	221.315	23.45	30	Pass
6	2437	23.91	23.65	23.29	691.080	28.40	30	Pass
11	2462	18.88	18.80	18.21	219.348	23.41	30	Pass

802.11n (HT40)

Chan.	Freq. (MHz)	Peak Power (dBm)			Total Power (mW)	Total Power (dBm)	Limit (dBm)	Pass / Fail
		Chain 0	Chain 1	Chain 2				
3	2422	14.65	14.61	13.97	83.027	19.19	30	Pass
6	2437	18.36	17.93	17.83	191.310	22.82	30	Pass
9	2452	11.80	11.71	11.61	44.449	16.48	30	Pass

4.5 Power Spectral Density Measurement

4.5.1 Limits of Power Spectral Density Measurement

The Maximum of Power Spectral Density Measurement is 8dBm.

4.5.2 Test Setup

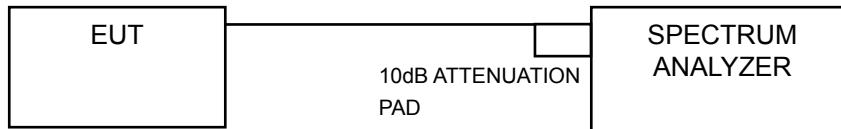

4.5.3 Test Instruments

Refer to section 4.1.2 to get information of above instrument.

4.5.4 Test Procedure

- Set analyzer center frequency to DTS channel center frequency.
- Set the span to 1.5 times the DTS bandwidth.
- Set the RBW to: $3 \text{ kHz} \leq \text{RBW} \leq 100 \text{ kHz}$.
- Set the VBW $\geq 3 \times \text{RBW}$.
- Detector = peak.
- Sweep time = auto couple.
- Trace mode = max hold.
- Allow trace to fully stabilize.
- Use the peak marker function to determine the maximum amplitude level within the RBW.

4.5.5 Deviation from Test Standard

No deviation.

4.5.6 EUT Operating Condition

Same as Item 4.3.6

4.5.7 Test Results

802.11b

TX chain	Channel	Freq. (MHz)	PSD (dBm)	10 log (N=3) dB	Total PSD (dBm)	Limit (dBm)	Pass /Fail
0	1	2412	-5.37	4.77	-0.60	6.23	Pass
	6	2437	-2.37	4.77	2.40	6.23	Pass
	11	2462	-5.68	4.77	-0.91	6.23	Pass
1	1	2412	-4.85	4.77	-0.08	6.23	Pass
	6	2437	-2.70	4.77	2.07	6.23	Pass
	11	2462	-5.67	4.77	-0.90	6.23	Pass
2	1	2412	-5.23	4.77	-0.46	6.23	Pass
	6	2437	-2.22	4.77	2.55	6.23	Pass
	11	2462	-6.23	4.77	-1.46	6.23	Pass

NOTE:

- Method 1 of power density measurement of KDB 662911 is using for calculating total power density. Total power density is summing entire spectra across corresponding frequency bins on the various outputs by computer.
- Directional gain = 3dBi + 10log(3) = 7.77dBi > 6dBi, so the power density limit shall be reduced to 8-(7.77-6) = 6.23dBm.

802.11g

TX chain	Channel	Freq. (MHz)	PSD (dBm)	10 log (N=3) dB	Total PSD (dBm)	Limit (dBm)	Pass /Fail
0	1	2412	-11.23	4.77	-6.46	6.23	Pass
	6	2437	-5.17	4.77	-0.40	6.23	Pass
	11	2462	-10.81	4.77	-6.04	6.23	Pass
1	1	2412	-11.46	4.77	-6.69	6.23	Pass
	6	2437	-5.90	4.77	-1.13	6.23	Pass
	11	2462	-11.10	4.77	-6.33	6.23	Pass
2	1	2412	-11.54	4.77	-6.77	6.23	Pass
	6	2437	-6.55	4.77	-1.78	6.23	Pass
	11	2462	-11.95	4.77	-7.18	6.23	Pass

NOTE:

- Method 1 of power density measurement of KDB 662911 is using for calculating total power density. Total power density is summing entire spectra across corresponding frequency bins on the various outputs by computer.
- Directional gain = 3dBi + 10log(3) = 7.77dBi > 6dBi, so the power density limit shall be reduced to 8-(7.77-6) = 6.23dBm.

802.11n (HT20)

TX chain	Channel	Freq. (MHz)	PSD (dBm)	10 log (N=3) dB	Total PSD (dBm)	Limit (dBm)	Pass /Fail
0	1	2412	-12.74	4.77	-7.97	6.23	Pass
	6	2437	-7.33	4.77	-2.56	6.23	Pass
	11	2462	-13.59	4.77	-8.82	6.23	Pass
1	1	2412	-12.75	4.77	-7.98	6.23	Pass
	6	2437	-5.93	4.77	-1.16	6.23	Pass
	11	2462	-12.49	4.77	-7.72	6.23	Pass
2	1	2412	-13.12	4.77	-8.35	6.23	Pass
	6	2437	-7.69	4.77	-2.92	6.23	Pass
	11	2462	-13.96	4.77	-9.19	6.23	Pass

NOTE:

- Method 1 of power density measurement of KDB 662911 is using for calculating total power density. Total power density is summing entire spectra across corresponding frequency bins on the various outputs by computer.
- Directional gain = 3dBi + 10log(3) = 7.77dBi > 6dBi, so the power density limit shall be reduced to 8-(7.77-6) = 6.23dBm.

802.11n (HT40)

TX chain	Channel	Freq. (MHz)	PSD (dBm)	10 log (N=3) dB	Total PSD (dBm)	Limit (dBm)	Pass /Fail
0	3	2422	-21.25	4.77	-16.48	6.23	Pass
	6	2437	-17.20	4.77	-12.43	6.23	Pass
	9	2452	-22.93	4.77	-18.16	6.23	Pass
1	3	2422	-21.20	4.77	-16.43	6.23	Pass
	6	2437	-17.57	4.77	-12.80	6.23	Pass
	9	2452	-22.89	4.77	-18.12	6.23	Pass
2	3	2422	-20.56	4.77	-15.79	6.23	Pass
	6	2437	-17.31	4.77	-12.54	6.23	Pass
	9	2452	-23.99	4.77	-19.22	6.23	Pass

NOTE:

- Method 1 of power density measurement of KDB 662911 is using for calculating total power density. Total power density is summing entire spectra across corresponding frequency bins on the various outputs by computer.
- Directional gain = 3dBi + 10log(3) = 7.77dBi > 6dBi, so the power density limit shall be reduced to 8-(7.77-6) = 6.23dBm.

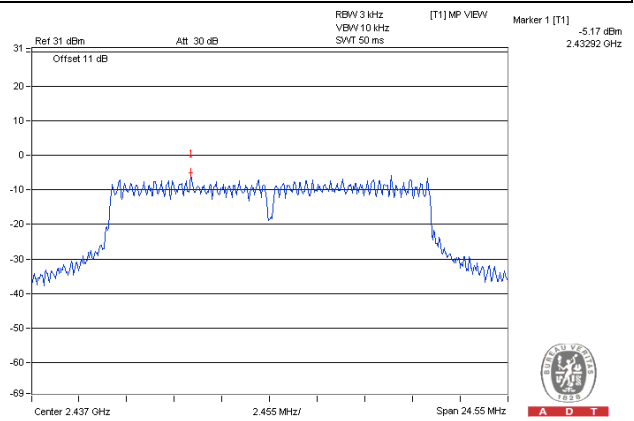
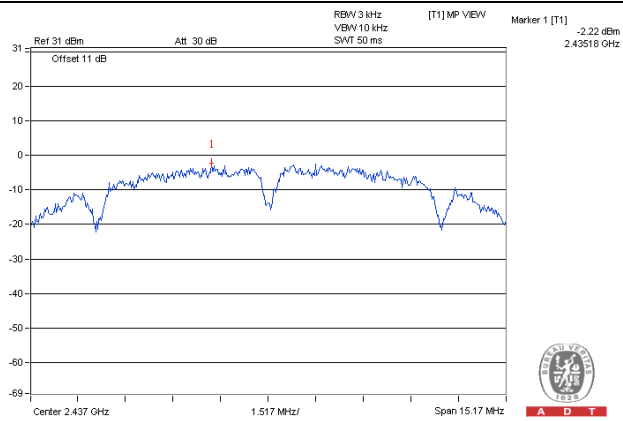
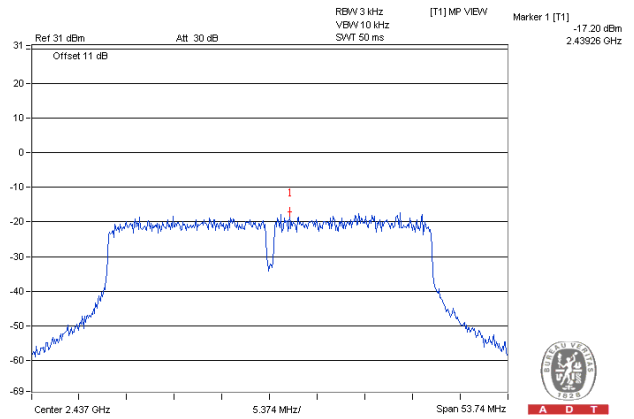
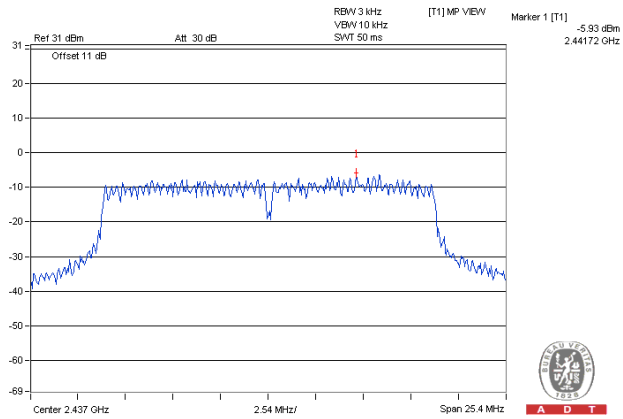
Spectrum Plot of Worst Value**802.11b****802.11g****802.11n (HT20)****802.11n (HT40)**

4.6 Conducted Out of Band Emission Measurement

4.6.1 Limits of Conducted Out of Band Emission Measurement

Below 20dB of the highest emission level of operating band (in 100kHz Resolution Bandwidth).

4.6.2 Test Setup

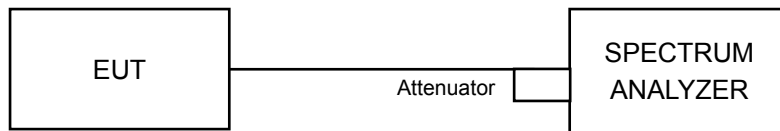

4.6.3 Test Instruments

Refer to section 4.1.2 to get information of above instrument.

4.6.4 Test Procedure

MEASUREMENT PROCEDURE REF

1. Set the RBW = 100 kHz.
2. Set the VBW \geq 300 kHz.
3. Detector = peak.
4. Sweep time = auto couple.
5. Trace mode = max hold.
6. Allow trace to fully stabilize.
7. Use the peak marker function to determine the maximum power level in any 100 kHz band segment within the fundamental EBW.

MEASUREMENT PROCEDURE OOB

1. Set RBW = 100 kHz.
2. Set VBW \geq 300 kHz.
3. Detector = peak.
4. Sweep = auto couple.
5. Trace Mode = max hold.
6. Allow trace to fully stabilize.
7. Use the peak marker function to determine the maximum amplitude level.

4.6.5 Deviation from Test Standard

No deviation.

4.6.6 EUT Operating Condition

Same as Item 4.3.6

4.6.7 Test Results

The spectrum plots are attached on the following pages. D1 line indicates the highest level, and D2 line indicates the 20dB offset below D1. It shows compliance with the requirement.

802.11b
CHAIN 0

CH 1

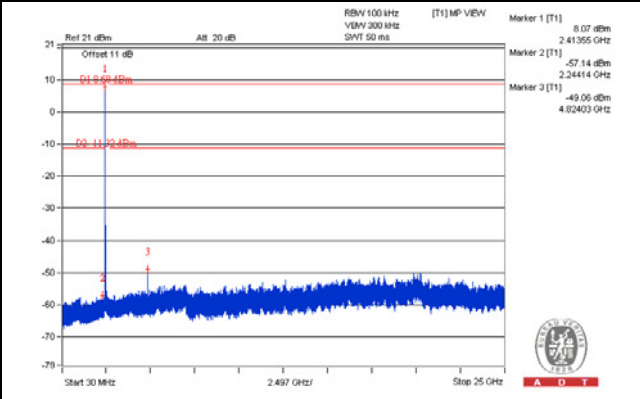
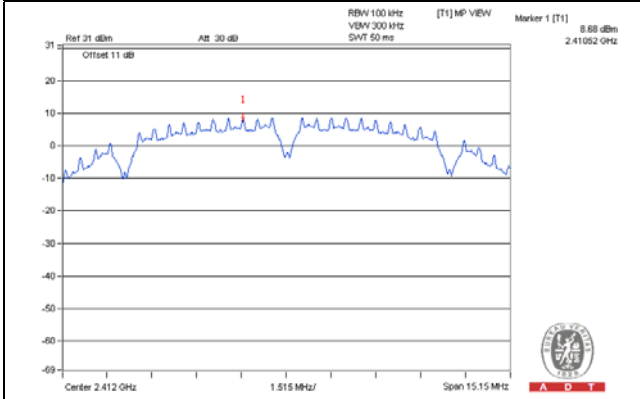

CH 6

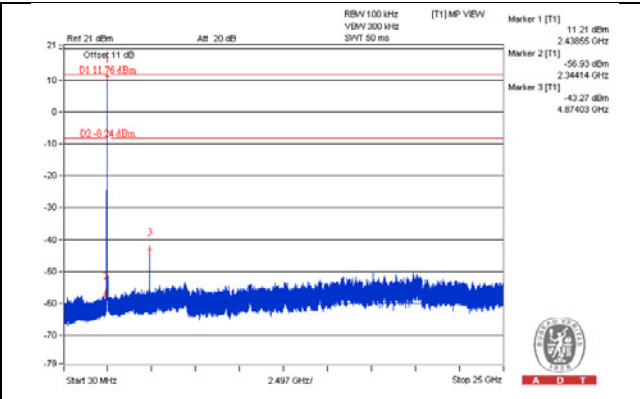
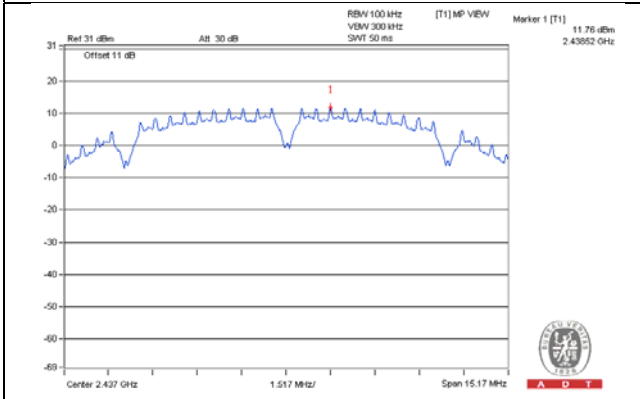

CH 11

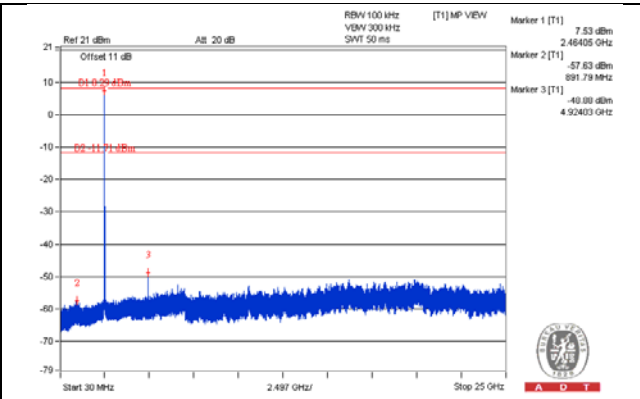
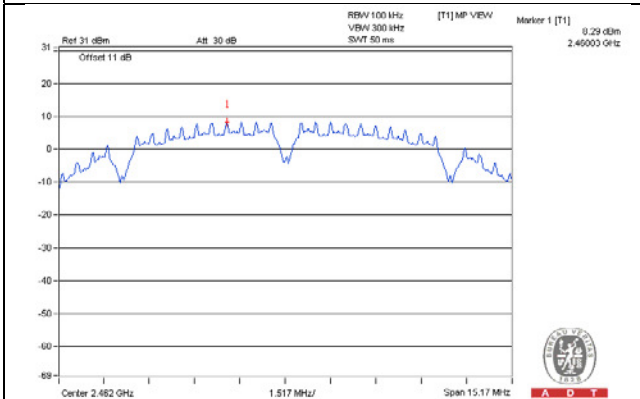

CH 1 Band edge

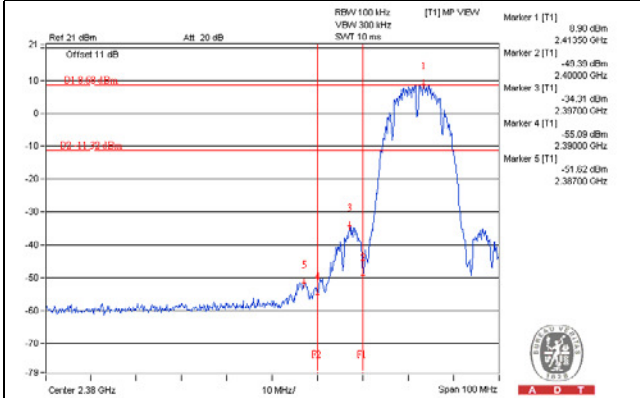

CH 11 Band edge

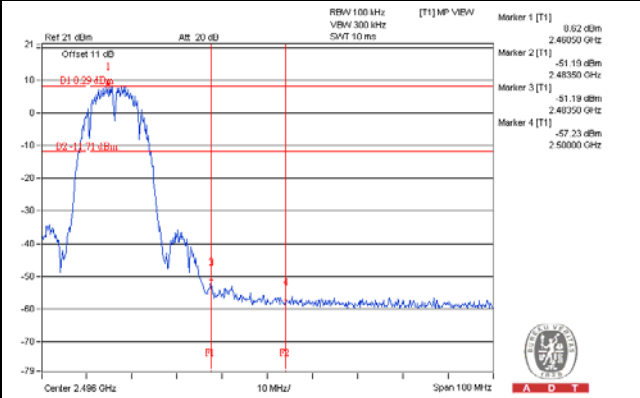

CHAIN 1

CH 1

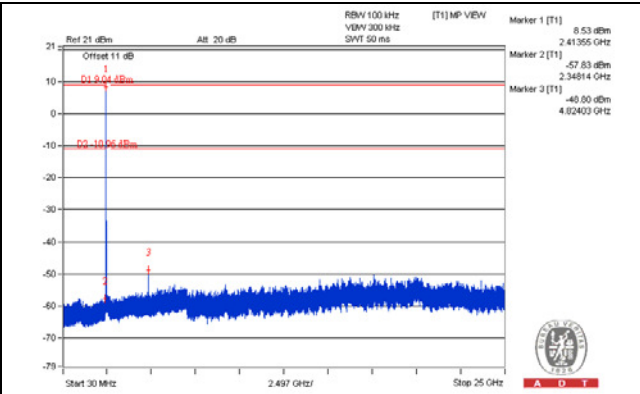
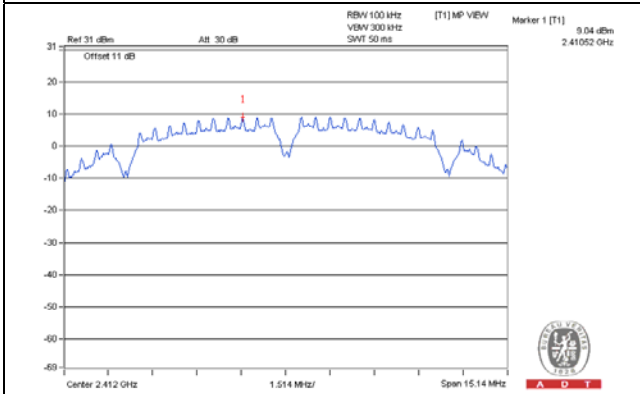

CH 6

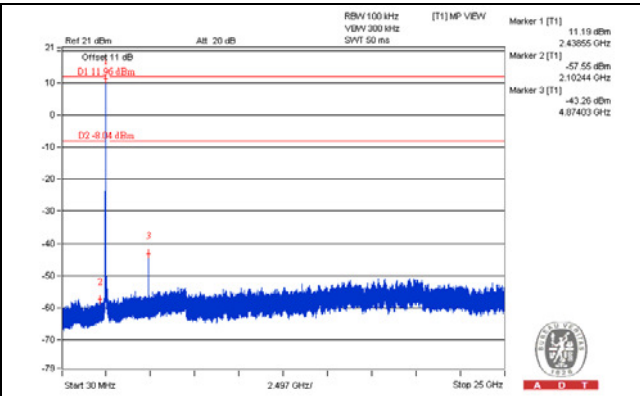
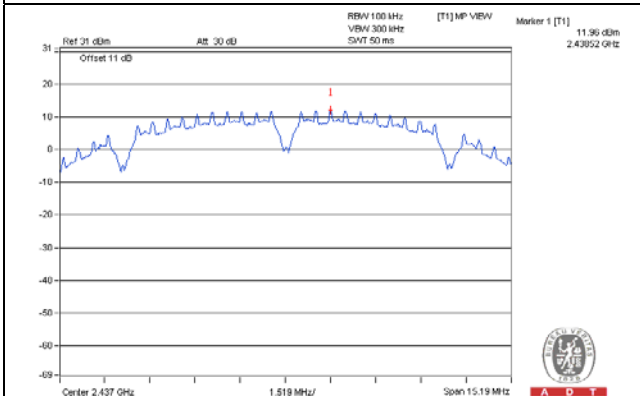

CH 11

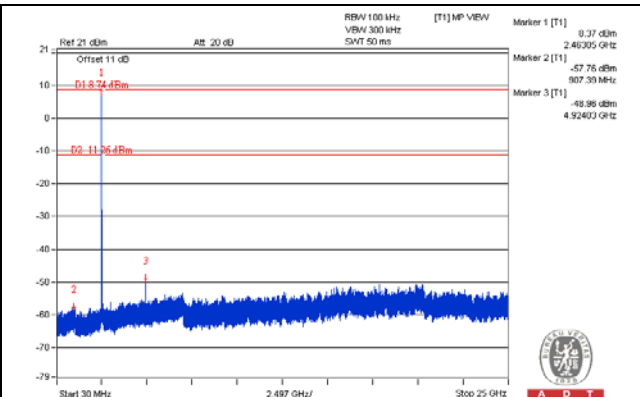
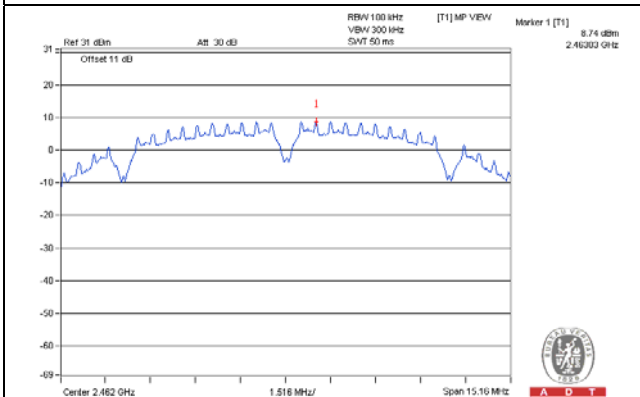

CH 1 Band edge

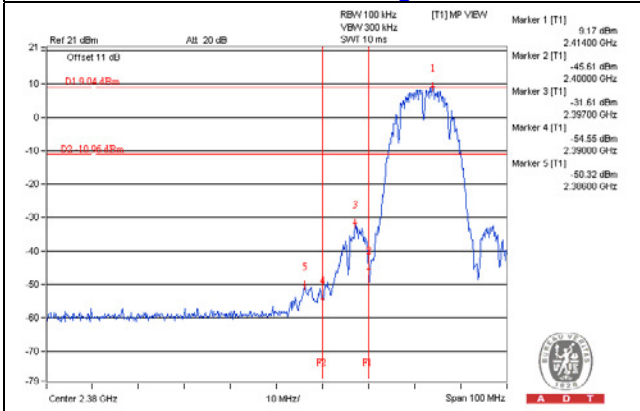

CH 11 Band edge

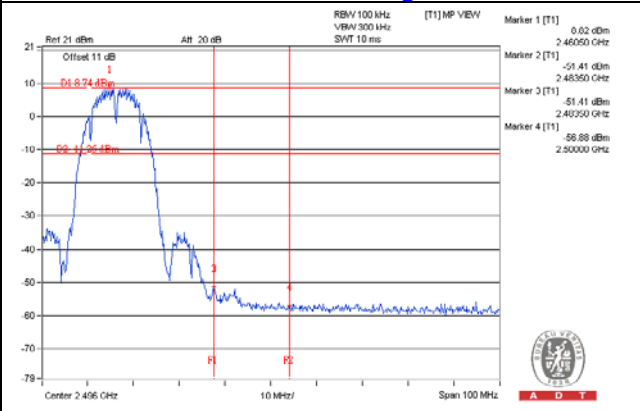

CHAIN 2

CH 1

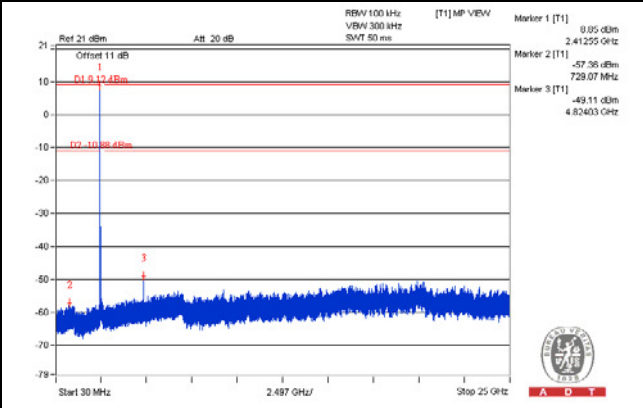
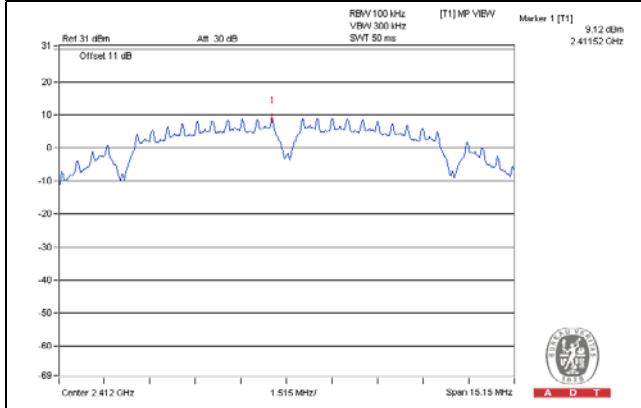

CH 6

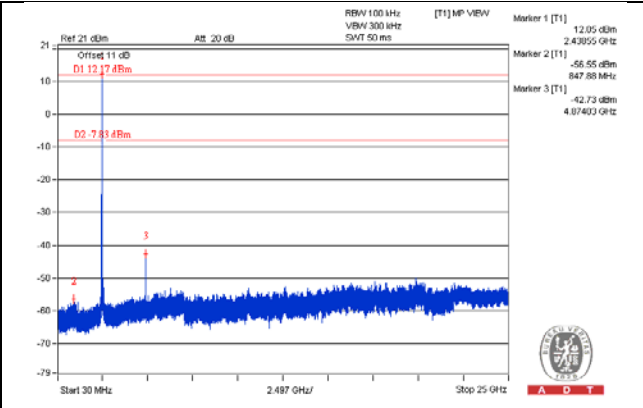
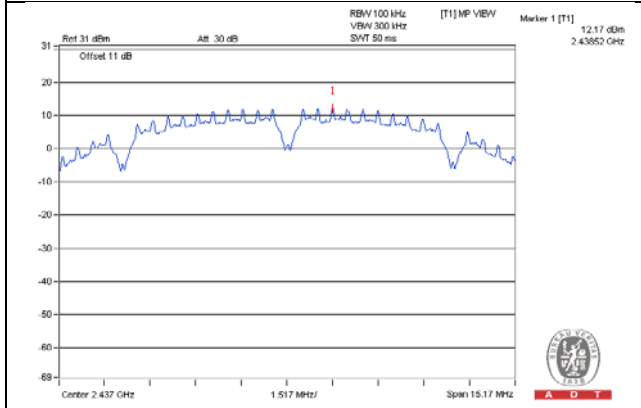

CH 11

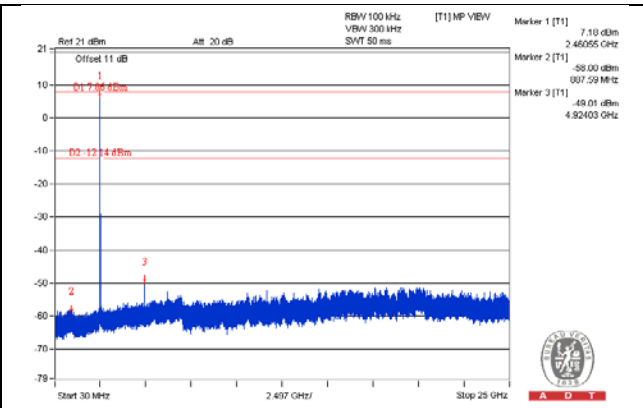
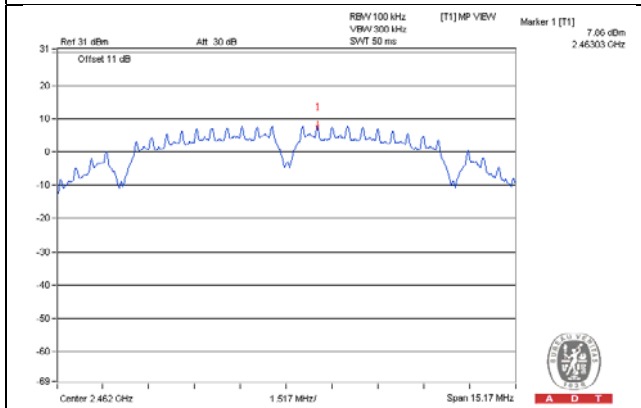

CH 1 Band edge

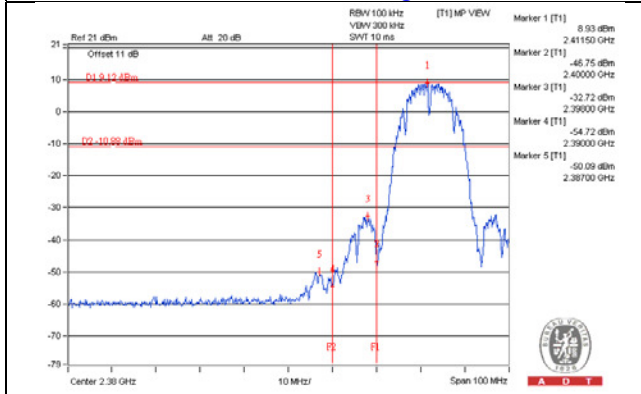

CH 11 Band edge

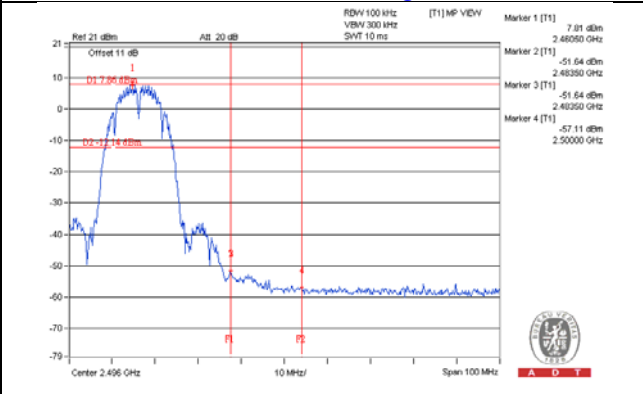

802.11g
CHAIN 0

CH 1

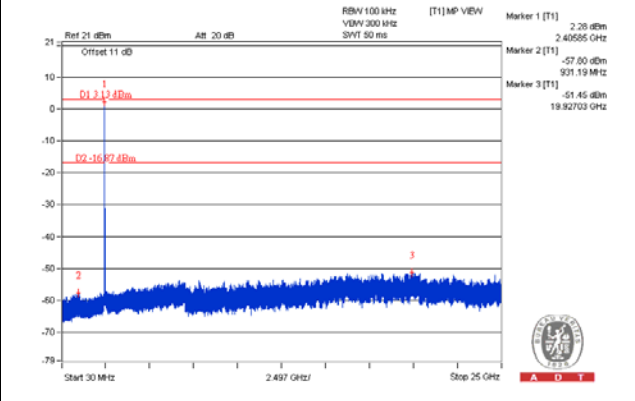
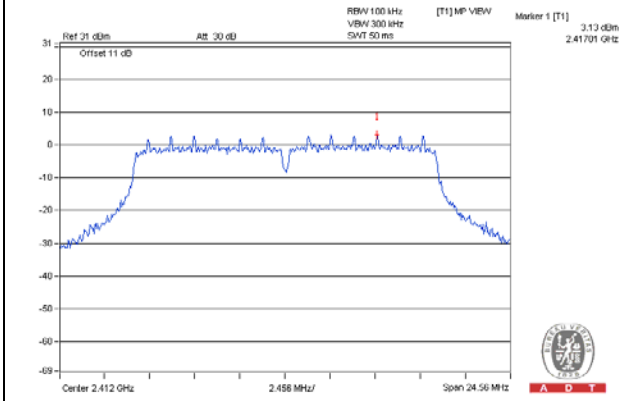

CH 6

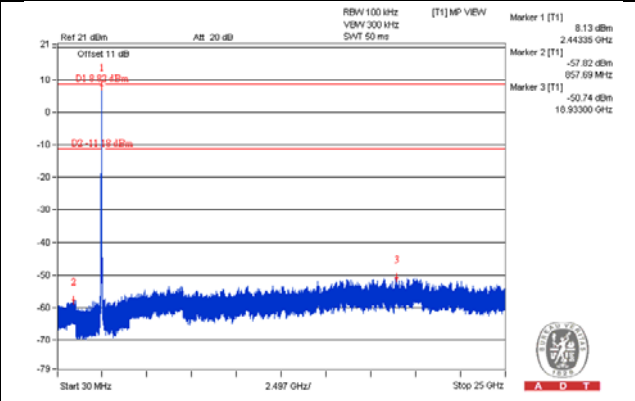
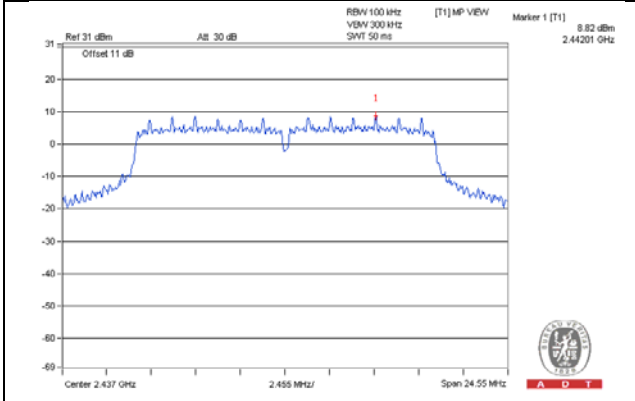

CH 11

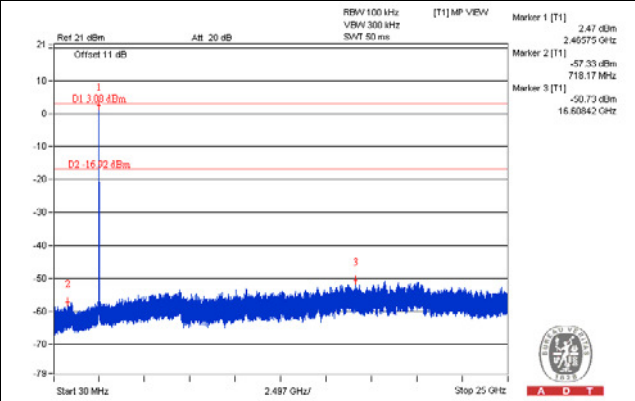
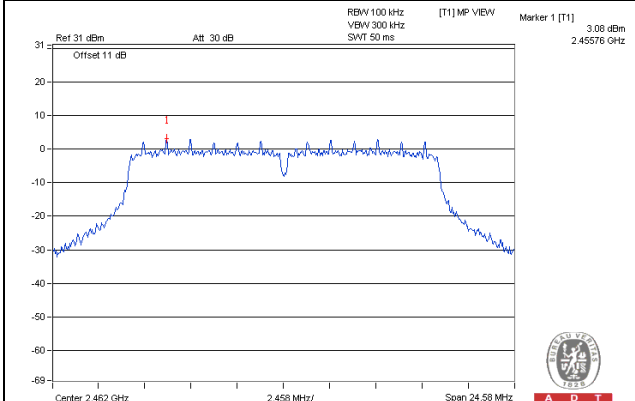

CH 1 Band edge

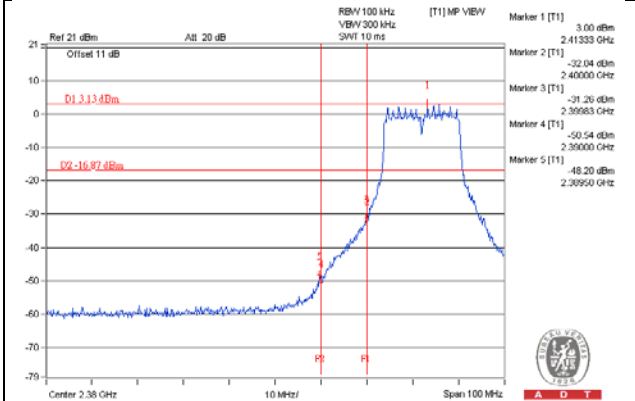

CH 11 Band edge

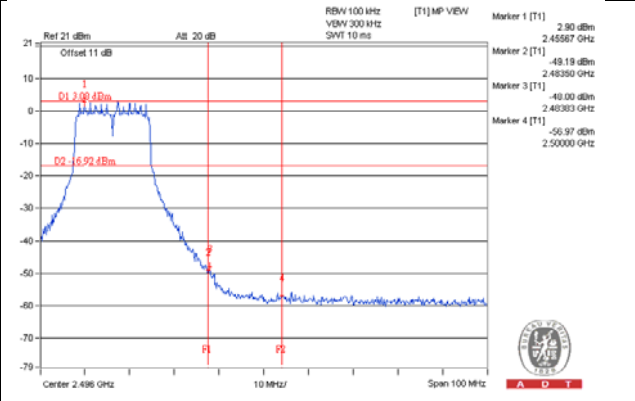

CHAIN 1

CH 1

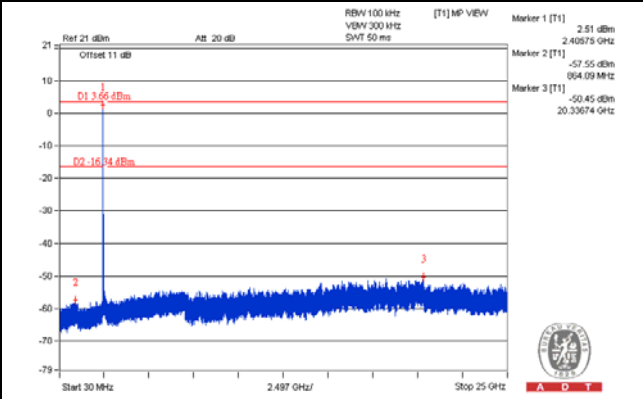
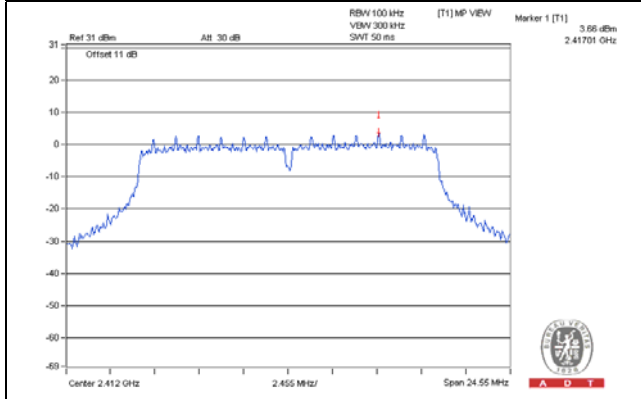

CH 6

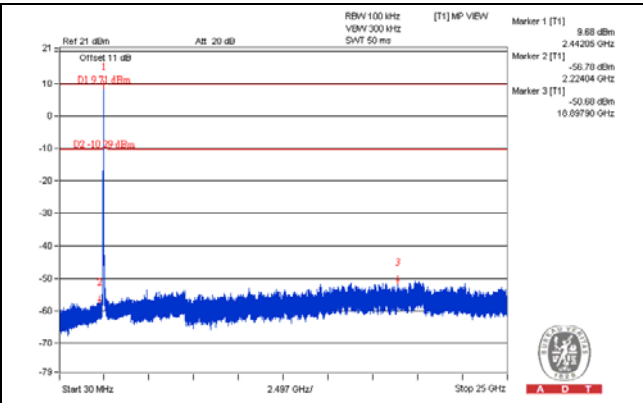
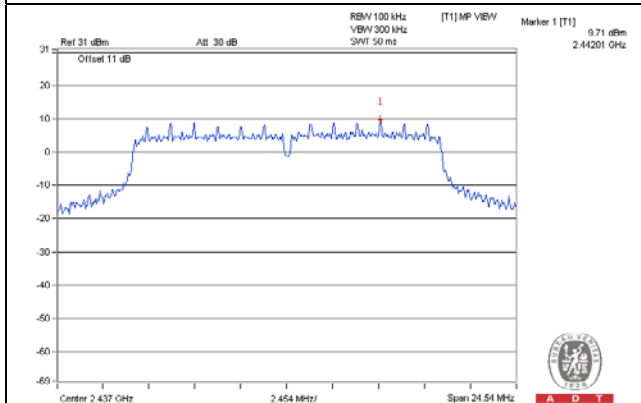

CH 11

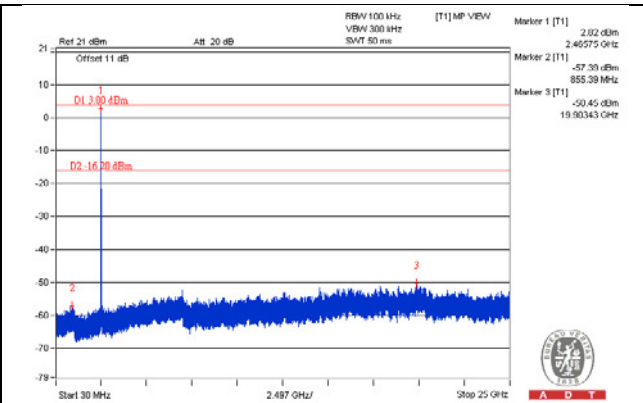
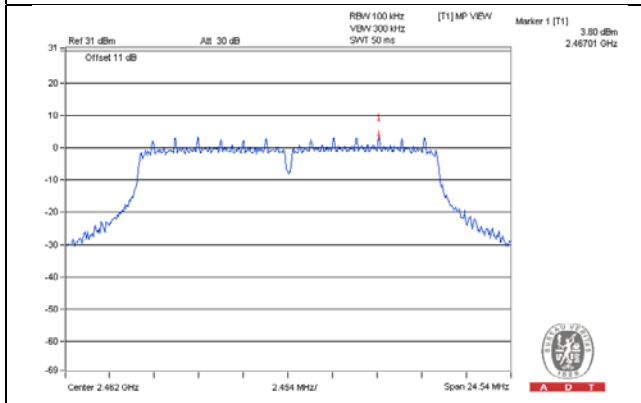

CH 1 Band edge

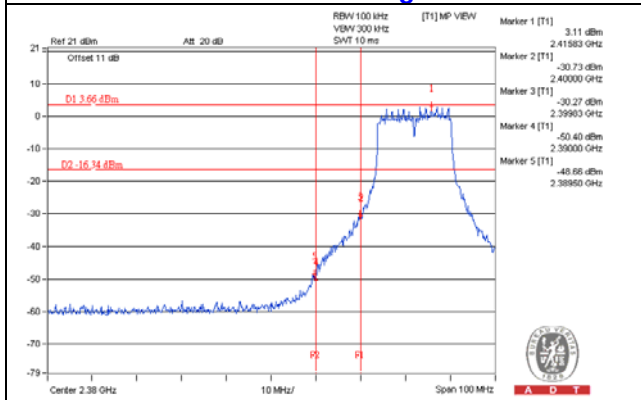

CH 11 Band edge

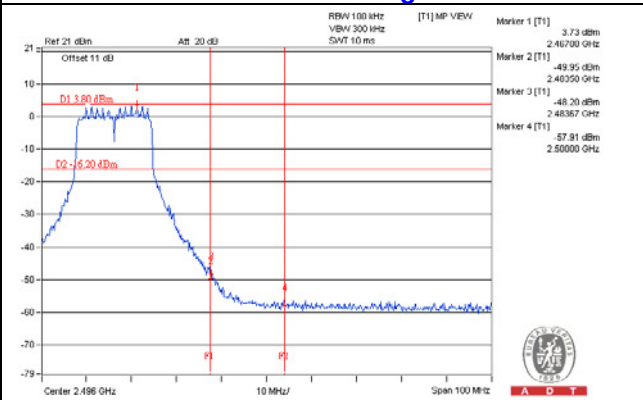

CHAIN 2

CH 1

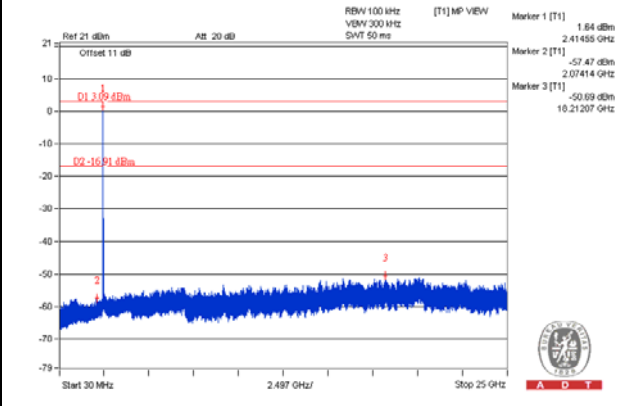
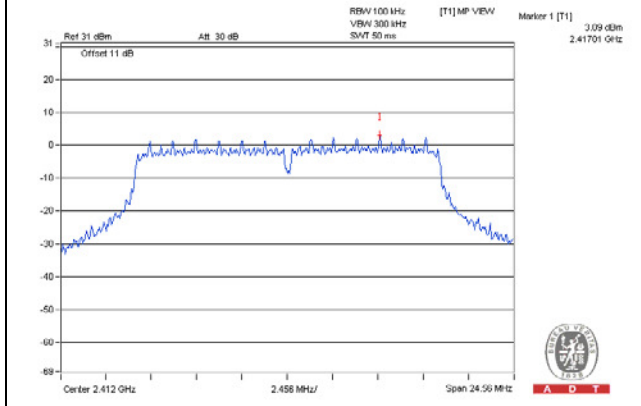

CH 6

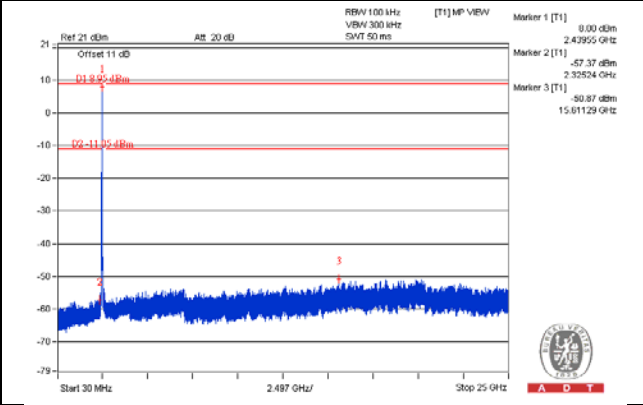
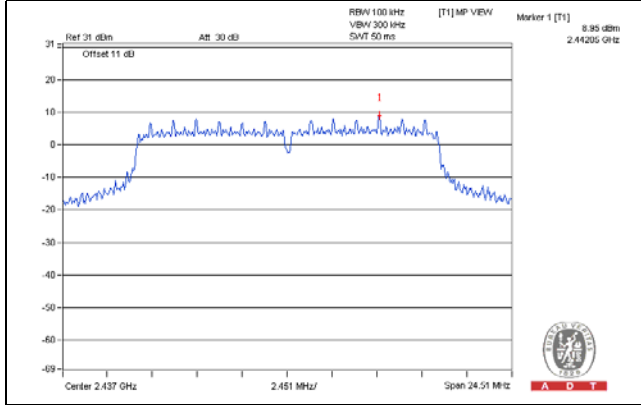

CH 11

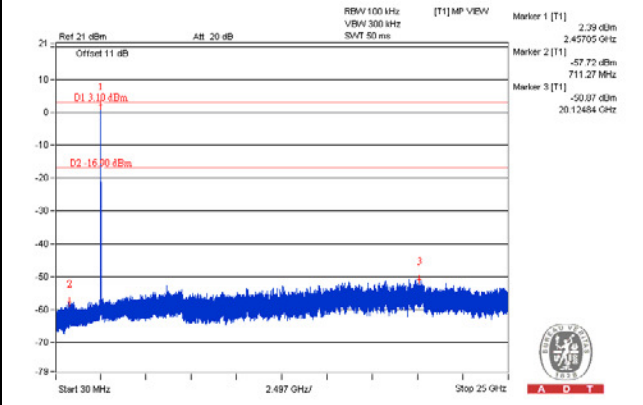
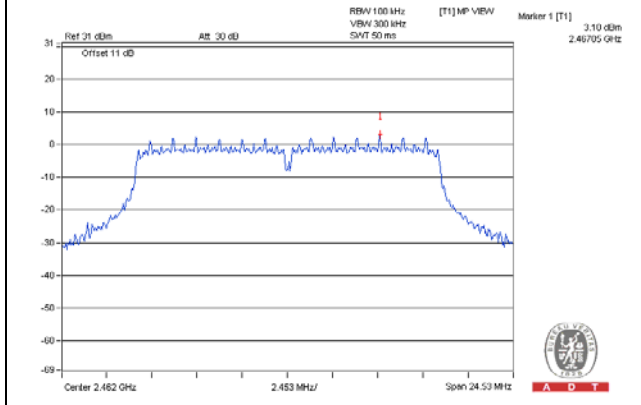

CH 1 Band edge

CH 11 Band edge

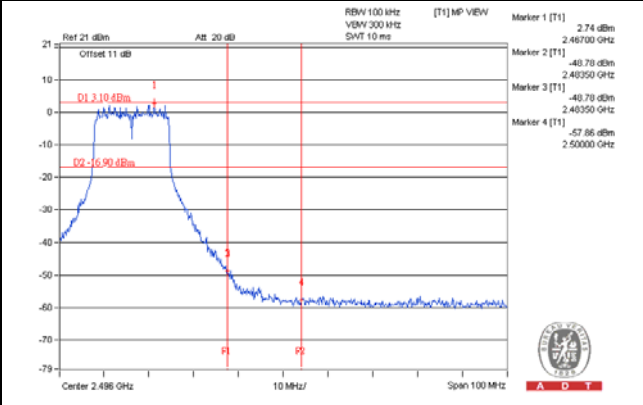
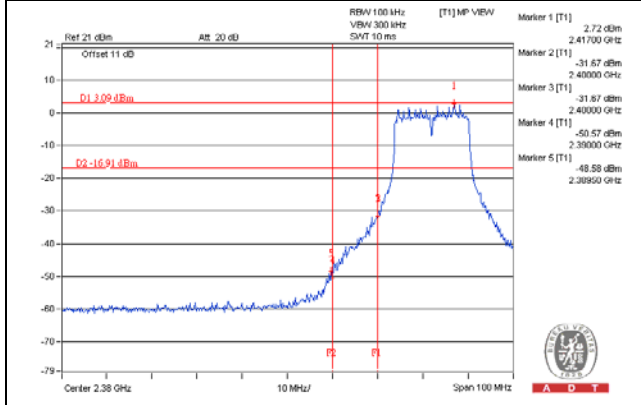

802.11n (HT20)
CHAIN 0

CH 1

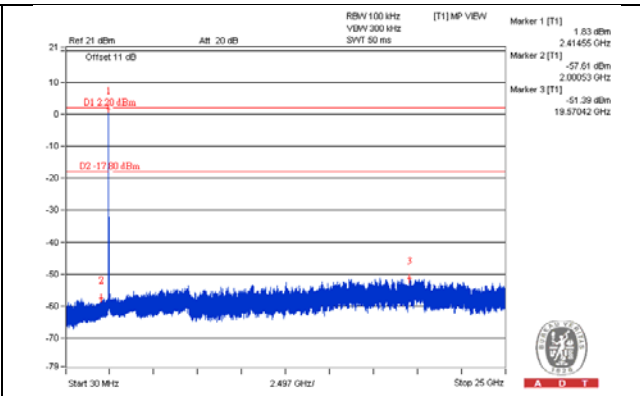
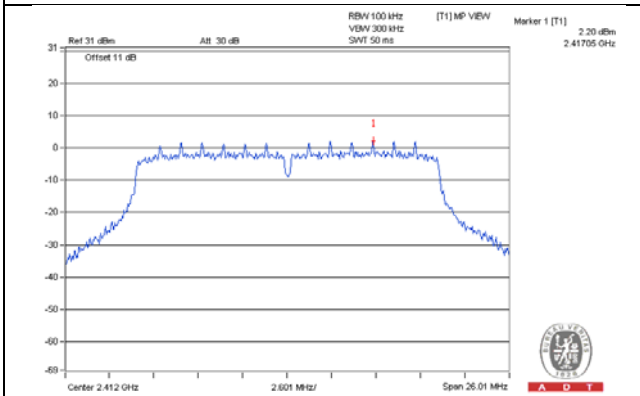

CH 6

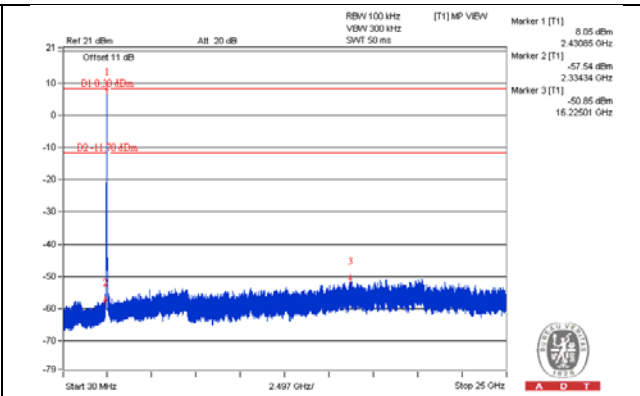
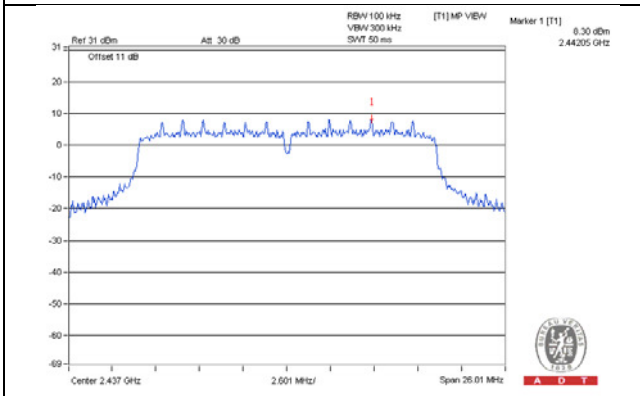

CH 11

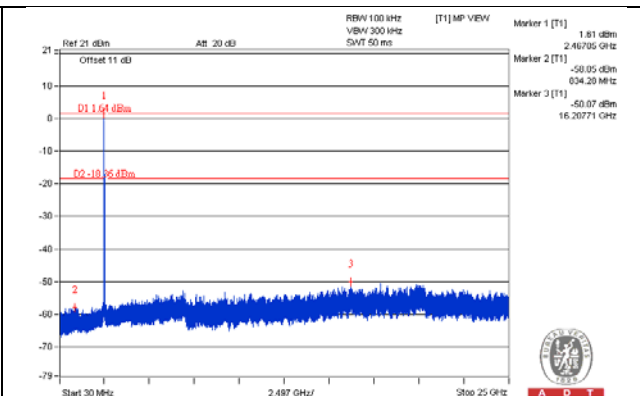
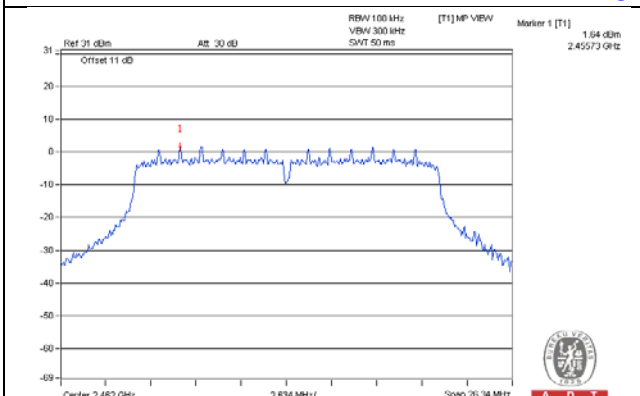

CH 1 Band edge

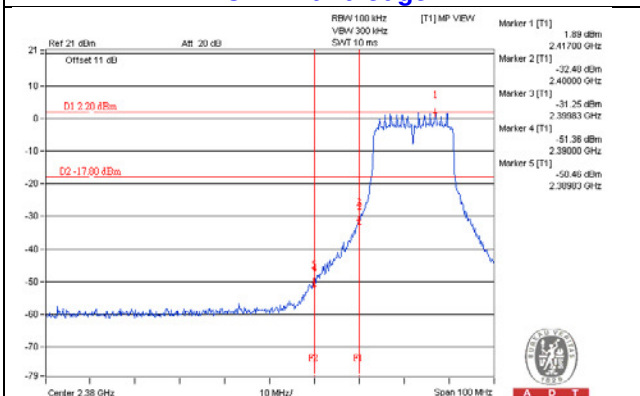

CH 11 Band edge

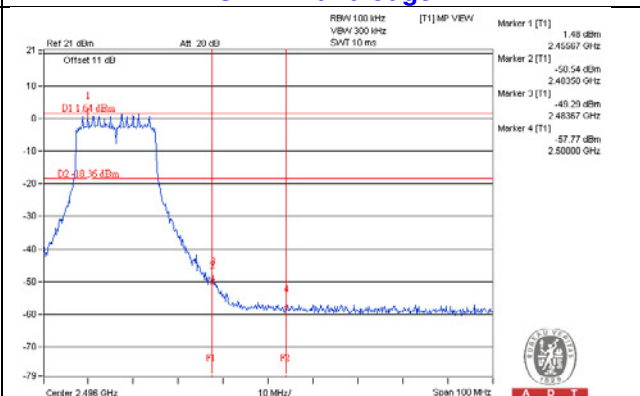

CHAIN 1

CH 1

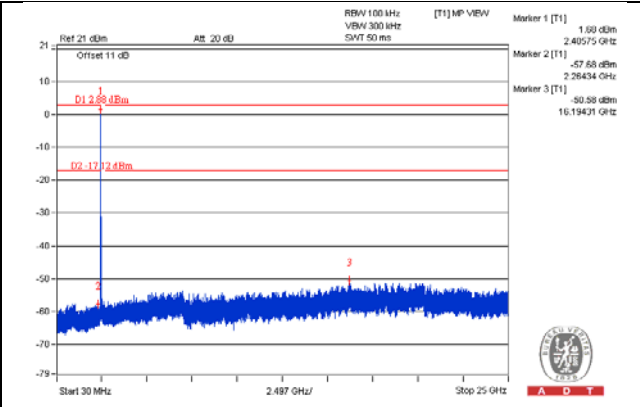
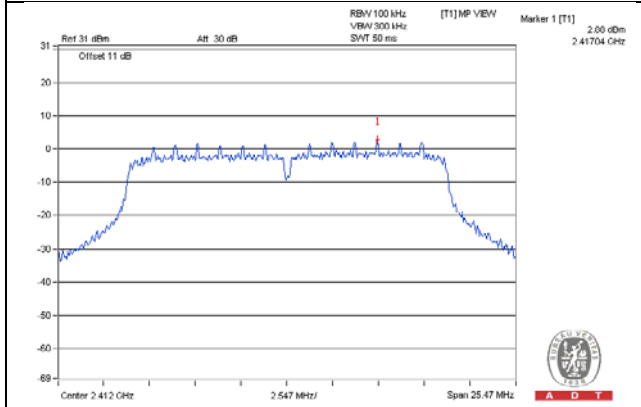

CH 6

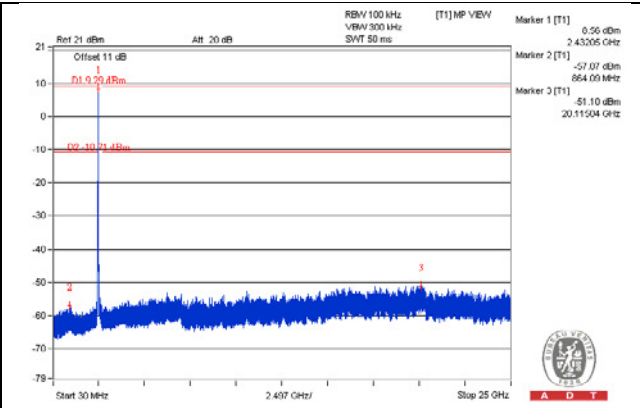
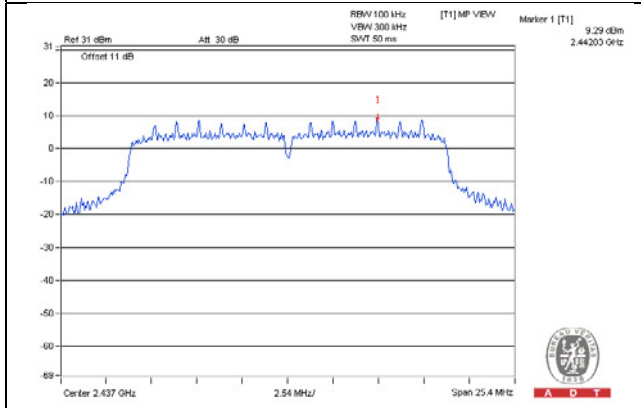

CH 11

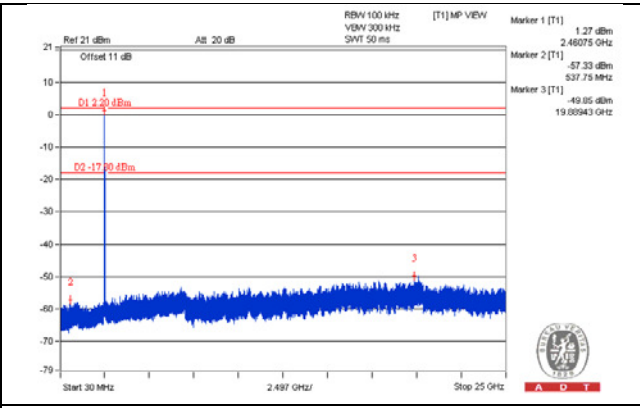
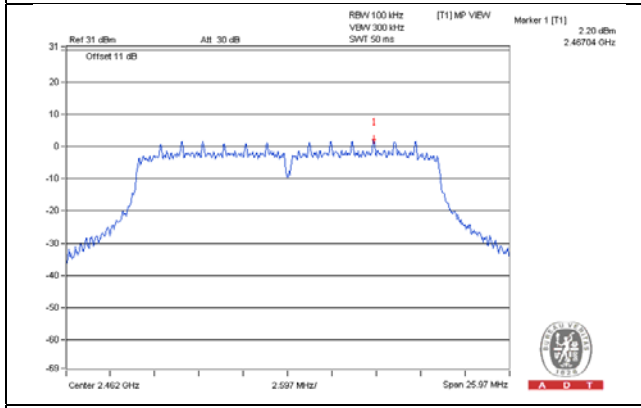

CH 1 Band edge

CH 11 Band edge

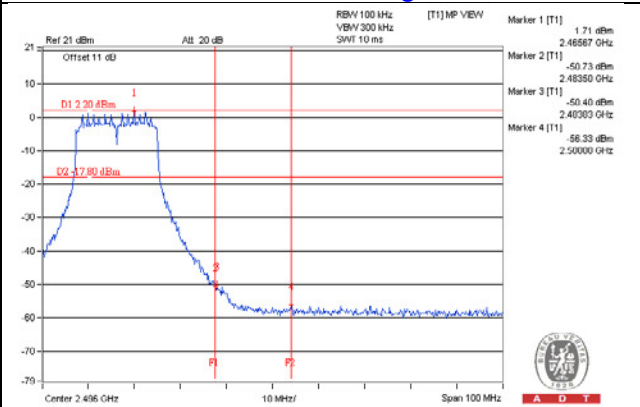
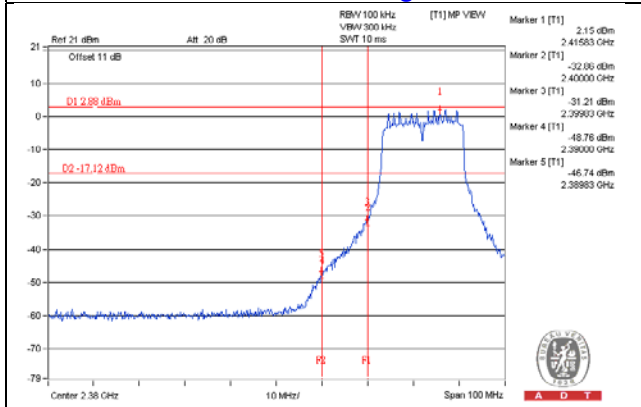

CHAIN 2

CH 1

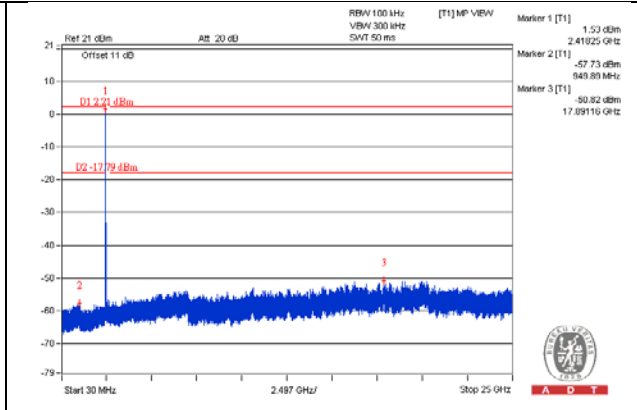
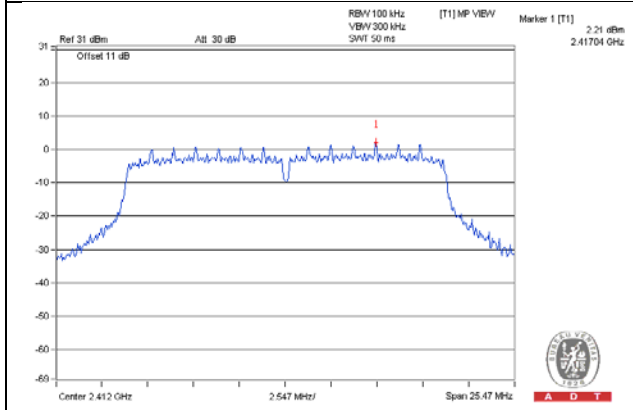

CH 6

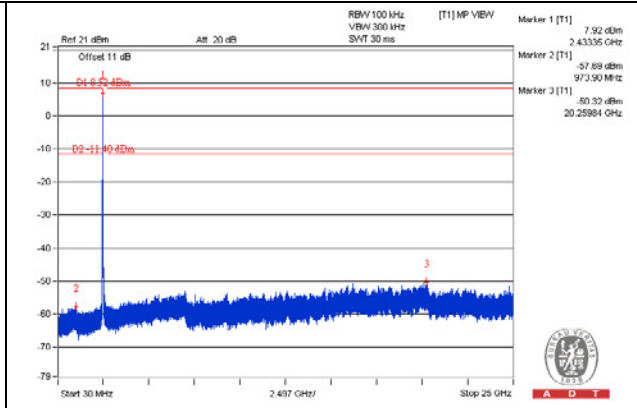
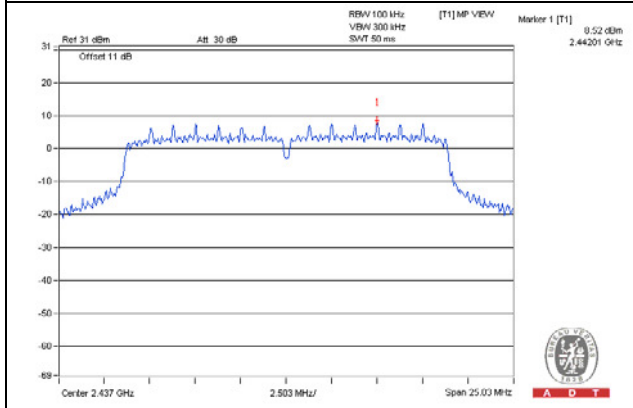

CH 11

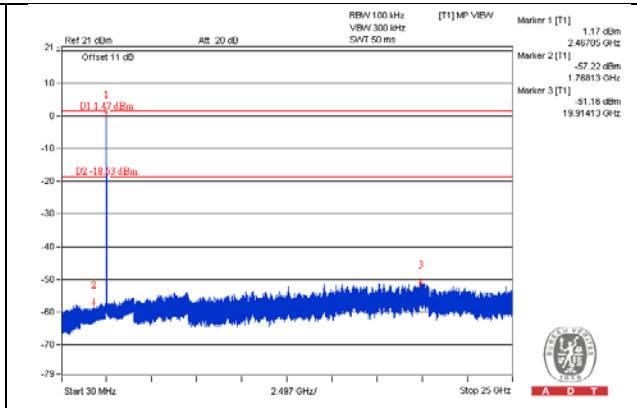
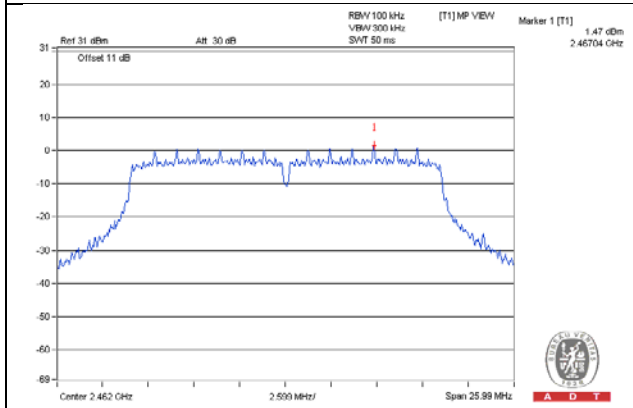

CH 1 Band edge

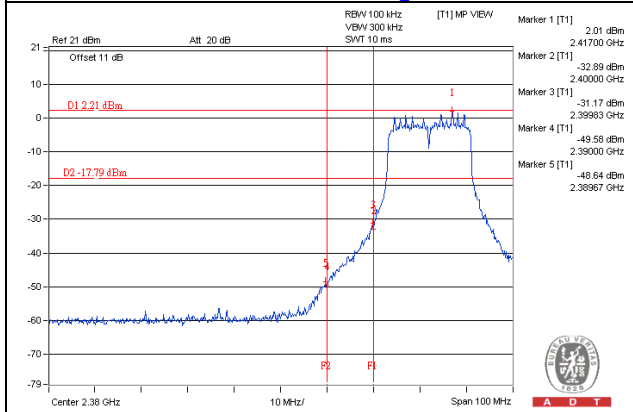

CH 11 Band edge

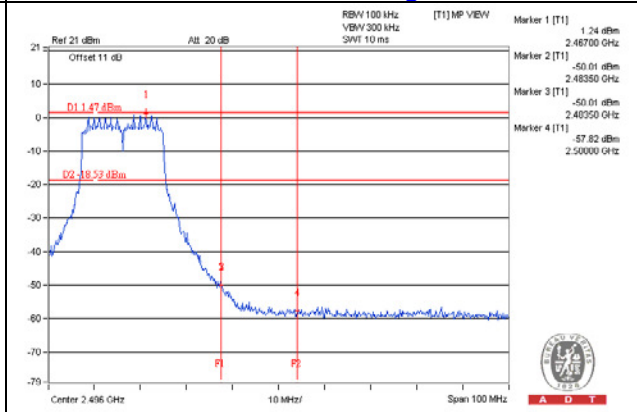

802.11n (HT40)
CHAIN 0

CH 3

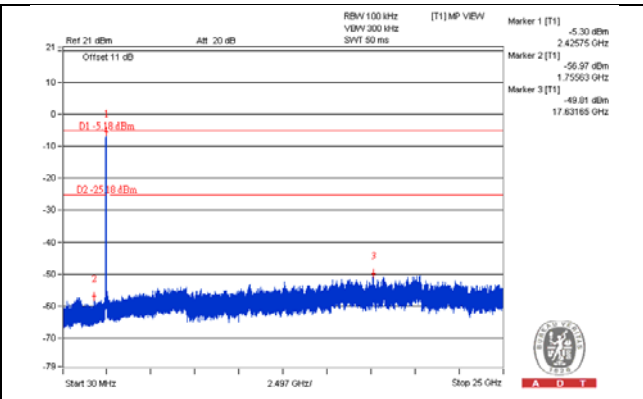
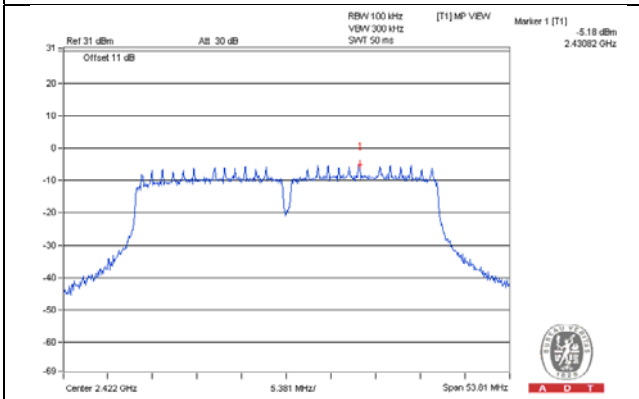

CH 6

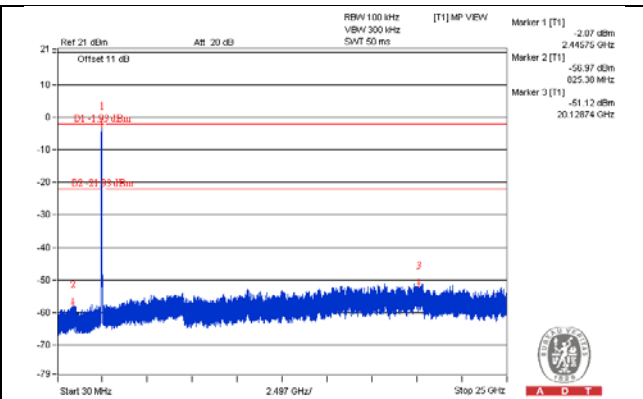
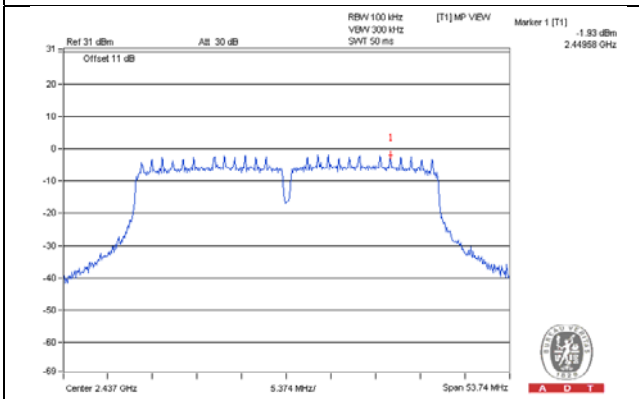

CH 9

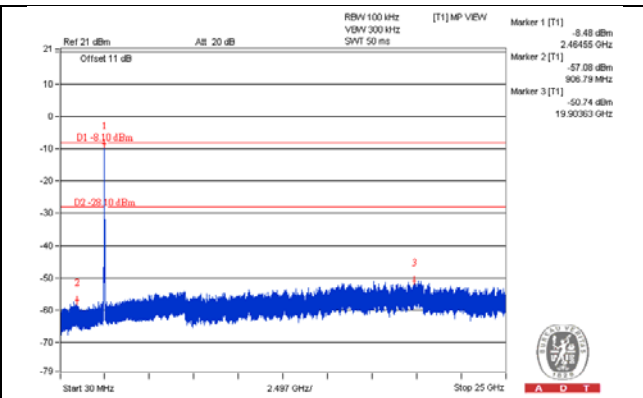
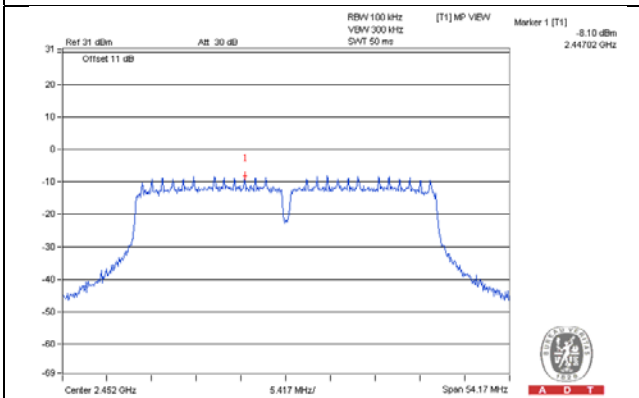

CH 3 Band edge

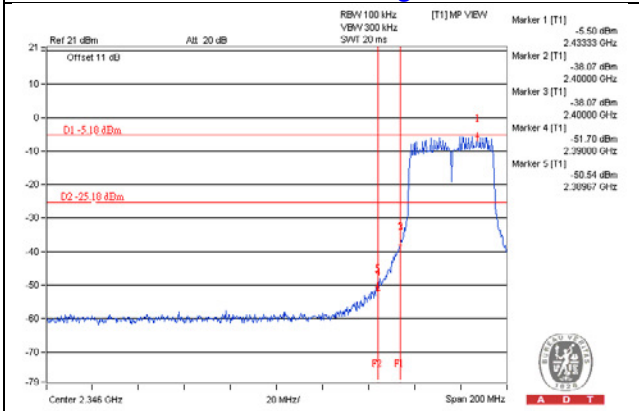

CH 9 Band edge

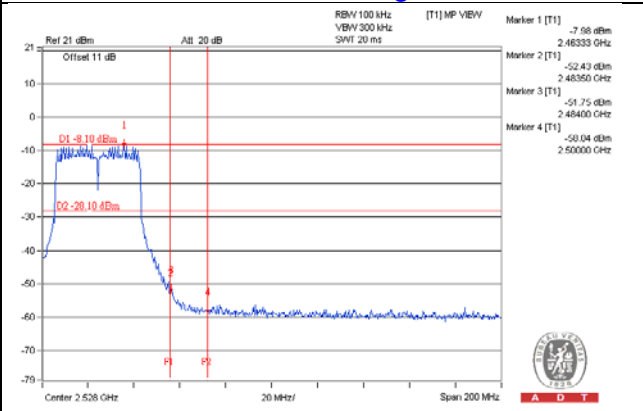

CHAIN 1

CH 3

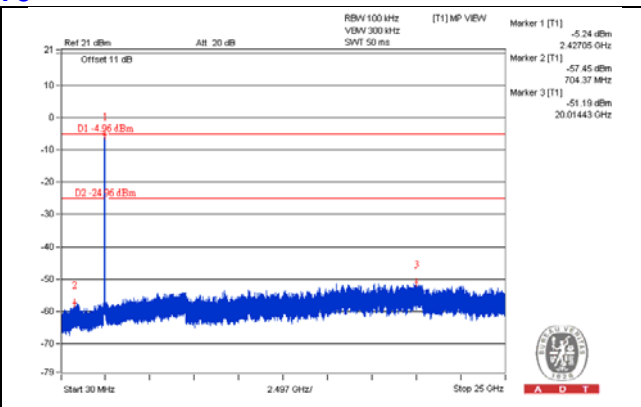
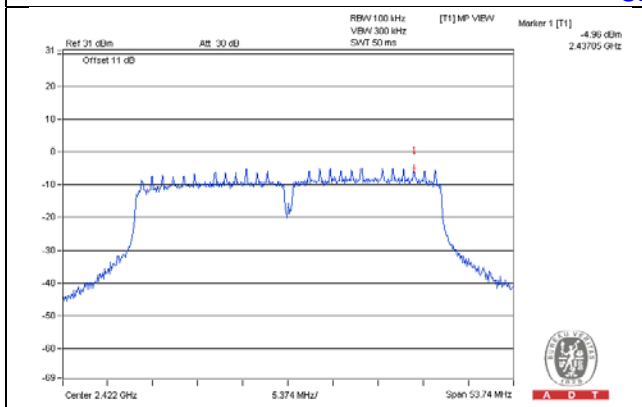

CH 6

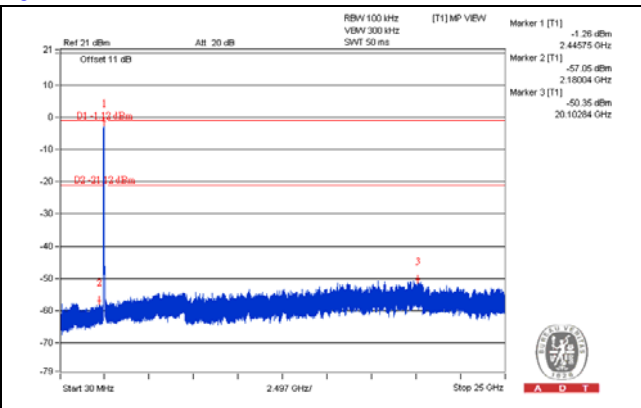
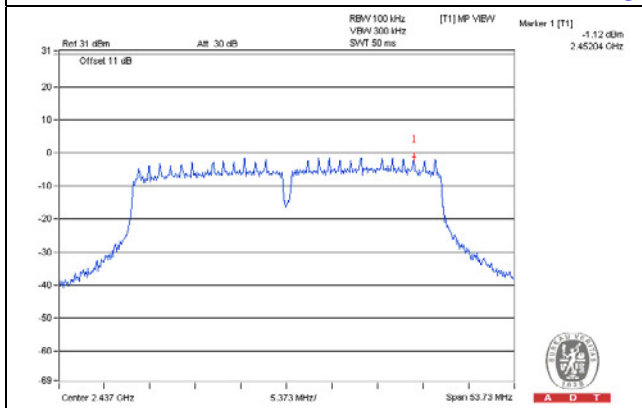

CH 9

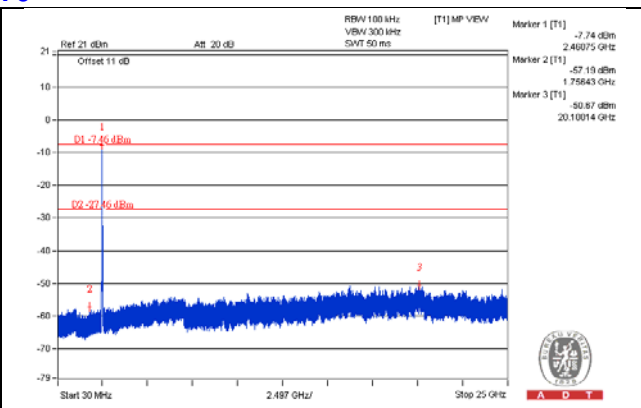
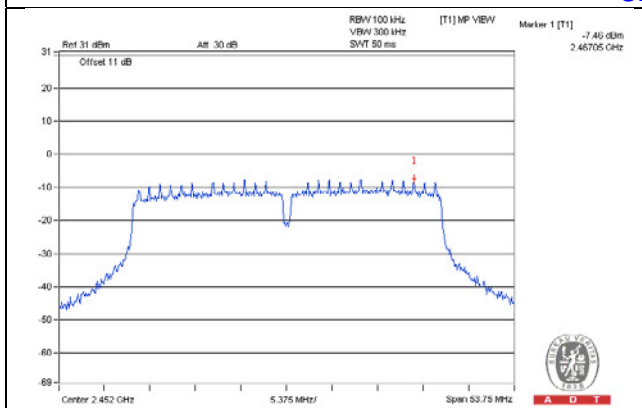

CH 3 Band edge

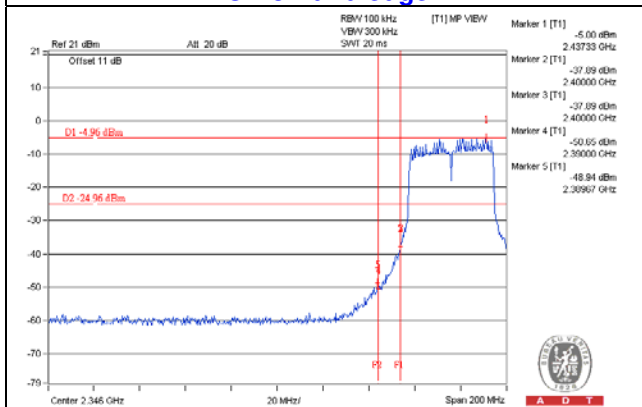

CH 9 Band edge

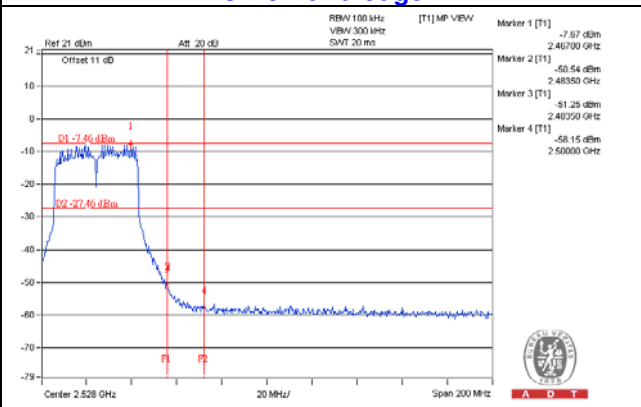

CHAIN 2

CH 3

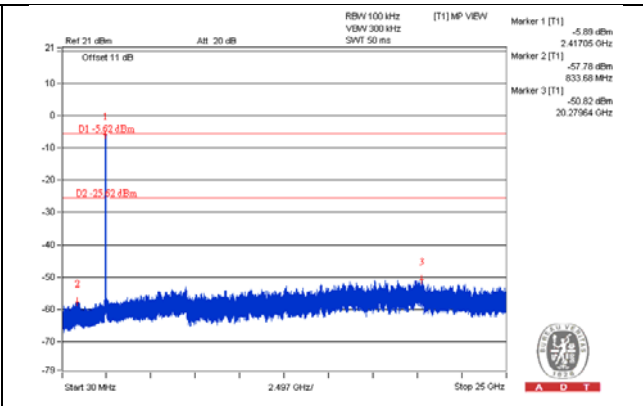
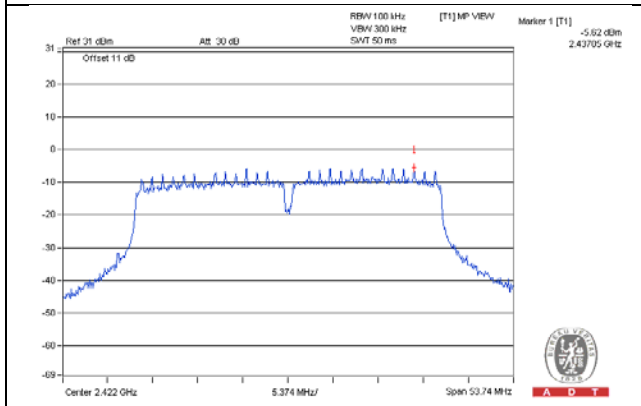

CH 6

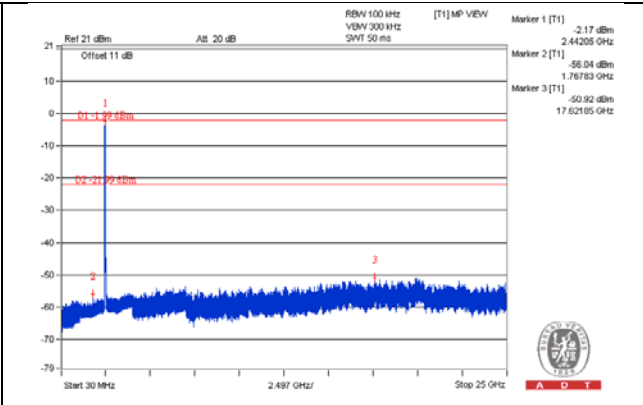
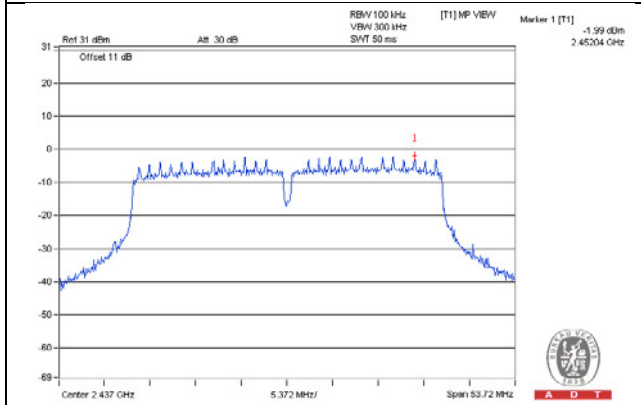

CH 9

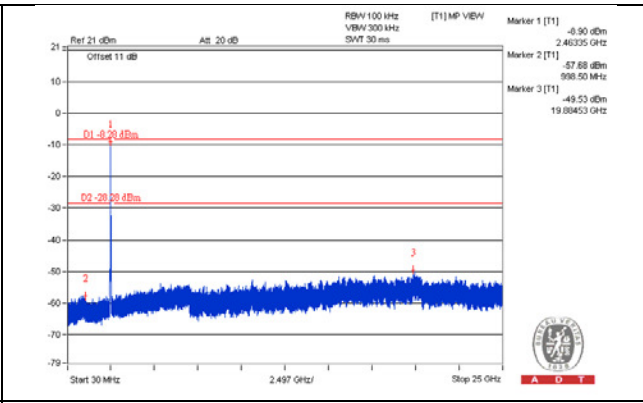
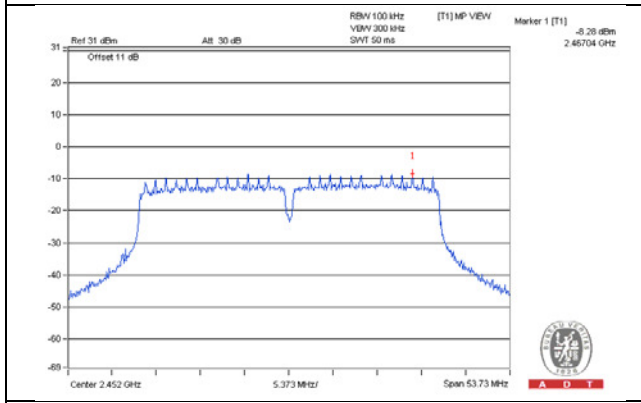

CH 3 Band edge

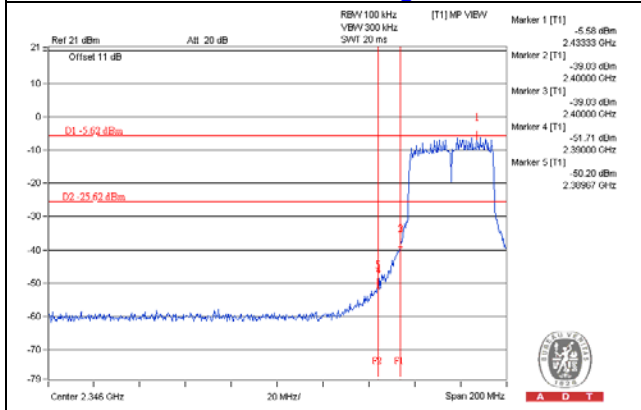

CH 9 Band edge

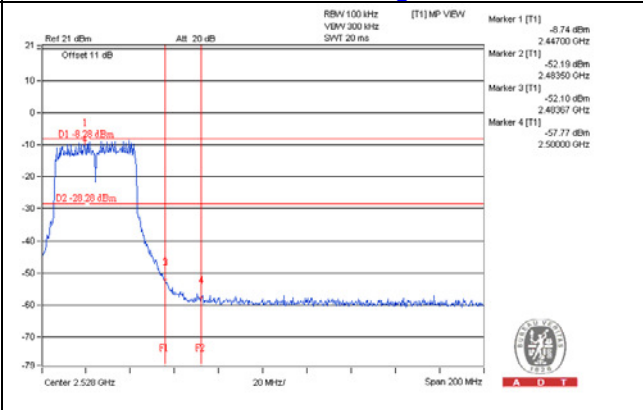

5 Pictures of Test Arrangements

Please refer to the attached file (Test Setup Photo).

Appendix – Information on the Testing Laboratories

We, Bureau Veritas Consumer Products Services (H.K.) Ltd., Taoyuan Branch, were founded in 1988 to provide our best service in EMC, Radio, Telecom and Safety consultation. Our laboratories are accredited and approved according to ISO/IEC 17025.

If you have any comments, please feel free to contact us at the following:

Linko EMC/RF Lab

Tel: 886-2-26052180

Fax: 886-2-26051924

Hsin Chu EMC/RF/Telecom Lab

Tel: 886-3-5935343

Fax: 886-3-5935342

Hwa Ya EMC/RF/Safety Lab

Tel: 886-3-3183232

Fax: 886-3-3270892

Email: service.adt@tw.bureauveritas.com

Web Site: www.bureauveritas-adt.com

The address and road map of all our labs can be found in our web site also.

--- END ---