



A D T

# FCC TEST REPORT (15.247)

**REPORT NO.:** RF990701C15

**MODEL NO.:** FAP-220Bxxxxxx

(where "x" is "0-9", "A-Z", "-", or blank)

**FCC ID:** TVE-220102

**RECEIVED:** Jul. 01, 2010

**TESTED:** Jul. 12 ~ Sep. 24, 2010

**ISSUED:** Sep. 29, 2010

**APPLICANT:** Fortinet Inc.

**ADDRESS:** 1090 Kifer Road Sunnyvale, CA 94086, USA

**ISSUED BY:** Bureau Veritas Consumer Products Services  
(H.K.) Ltd., Taoyuan Branch

**LAB ADDRESS:** No. 47, 14th Ling, Chia Pau Tsuen, Lin Kou  
Hsiang, Taipei Hsien 244, Taiwan, R.O.C.

**TEST LOCATION:** No. 19, Hwa Ya 2nd Rd, Wen Hwa Tsuen, Kwei  
Shan Hsiang, Taoyuan Hsien 333, Taiwan,  
R.O.C.

This test report consists of 165 pages in total. It may be duplicated completely for legal use with the approval of the applicant. It should not be reproduced except in full, without the written approval of our laboratory. The client should not use it to claim product, certification, approval or endorsement by TAF or any government agency. The test results in the report only apply to the tested sample.





## TABLE OF CONTENTS

1.	CERTIFICATION.....	5
2.	SUMMARY OF TEST RESULTS .....	6
2.1	MEASUREMENT UNCERTAINTY .....	6
3.	GENERAL INFORMATION.....	7
3.1	GENERAL DESCRIPTION OF EUT .....	7
3.2	DESCRIPTION OF TEST MODES .....	9
3.2.1	CONFIGURATION OF SYSTEM UNDER TEST .....	10
3.2.2	TEST MODE APPLICABILITY AND TESTED CHANNEL DETAIL .....	11
3.3	GENERAL DESCRIPTION OF APPLIED STANDARDS .....	15
3.4	DESCRIPTION OF SUPPORT UNITS .....	15
4.	TEST TYPES AND RESULTS (FOR 2.4GHz BAND) .....	16
4.1	RADIATED EMISSION MEASUREMENT .....	16
4.1.1	LIMITS OF RADIATED EMISSION MEASUREMENT .....	16
4.1.2	TEST INSTRUMENTS.....	17
4.1.3	TEST PROCEDURES .....	18
4.1.4	DEVIATION FROM TEST STANDARD.....	18
4.1.5	TEST SETUP .....	19
4.1.6	EUT OPERATING CONDITIONS .....	19
4.1.7	TEST RESULTS .....	20
4.2	CONDUCTED EMISSION MEASUREMENT .....	48
4.2.1	LIMITS OF CONDUCTED EMISSION MEASUREMENT .....	48
4.2.2	TEST INSTRUMENTS.....	48
4.2.3	TEST PROCEDURES .....	49
4.2.4	DEVIATION FROM TEST STANDARD.....	49
4.2.5	TEST SETUP .....	50
4.2.6	EUT OPERATING CONDITIONS .....	50
4.2.7	TEST RESULTS .....	51
4.3	6dB BANDWIDTH MEASUREMENT .....	59
4.3.1	LIMITS OF 6dB BANDWIDTH MEASUREMENT .....	59
4.3.2	TEST INSTRUMENTS.....	59
4.3.3	TEST PROCEDURE.....	59
4.3.4	DEVIATION FROM TEST STANDARD.....	59
4.3.5	TEST SETUP .....	60
4.3.6	EUT OPERATING CONDITIONS .....	60
4.3.7	TEST RESULTS .....	61
4.4	MAXIMUM OUTPUT POWER .....	69
4.4.1	LIMITS OF MAXIMUM OUTPUT POWER MEASUREMENT.....	69
4.4.2	INSTRUMENTS.....	69
4.4.3	TEST PROCEDURES .....	69
4.4.4	DEVIATION FROM TEST STANDARD.....	70
4.4.5	TEST SETUP .....	70
4.4.6	EUT OPERATING CONDITIONS .....	70
4.4.7	TEST RESULTS .....	71
4.5	POWER SPECTRAL DENSITY MEASUREMENT.....	73
4.5.1	LIMITS OF POWER SPECTRAL DENSITY MEASUREMENT .....	73
4.5.2	TEST INSTRUMENTS.....	73
4.5.3	TEST PROCEDURE.....	73
4.5.4	DEVIATION FROM TEST STANDARD.....	74
4.5.5	TEST SETUP .....	74



4.5.6	EUT OPERATING CONDITION.....	74
4.5.7	TEST RESULTS .....	75
4.6	BAND EDGES MEASUREMENT .....	83
4.6.1	LIMITS OF BAND EDGES MEASUREMENT .....	83
4.6.2	TEST INSTRUMENTS.....	83
4.6.3	TEST PROCEDURE.....	84
4.6.4	DEVIATION FROM TEST STANDARD.....	84
4.6.5	EUT OPERATING CONDITION.....	84
4.6.6	TEST RESULTS .....	85
5.	TEST TYPES AND RESULTS (FOR 5.0GHz BAND).....	117
5.1	RADIATED EMISSION MEASUREMENT .....	117
5.1.1	LIMITS OF RADIATED EMISSION MEASUREMENT .....	117
5.1.2	TEST INSTRUMENTS.....	118
5.1.3	TEST PROCEDURES .....	119
5.1.4	DEVIATION FROM TEST STANDARD.....	119
5.1.5	TEST SETUP .....	120
5.1.6	EUT OPERATING CONDITIONS .....	120
5.1.7	TEST RESULTS .....	121
5.2	CONDUCTED EMISSION MEASUREMENT .....	131
5.2.1	LIMITS OF CONDUCTED EMISSION MEASUREMENT .....	131
5.2.2	TEST INSTRUMENTS.....	131
5.2.3	TEST PROCEDURES .....	132
5.2.4	DEVIATION FROM TEST STANDARD.....	132
5.2.5	TEST SETUP .....	133
5.2.6	EUT OPERATING CONDITIONS .....	133
5.2.7	TEST RESULTS .....	134
5.3	6dB BANDWIDTH MEASUREMENT.....	138
5.3.1	LIMITS OF 6dB BANDWIDTH MEASUREMENT .....	138
5.3.2	TEST INSTRUMENTS.....	138
5.3.3	TEST PROCEDURE.....	138
5.3.4	DEVIATION FROM TEST STANDARD.....	139
5.3.5	TEST SETUP.....	139
5.3.6	EUT OPERATING CONDITIONS .....	139
5.3.7	TEST RESULTS .....	140
5.4	MAXIMUM OUTPUT POWER .....	143
5.4.1	LIMITS OF MAXIMUM OUTPUT POWER MEASUREMENT.....	143
5.4.2	INSTRUMENTS.....	143
5.4.3	TEST PROCEDURES .....	143
5.4.4	DEVIATION FROM TEST STANDARD.....	144
5.4.5	TEST SETUP.....	144
5.4.6	EUT OPERATING CONDITIONS .....	144
5.4.7	TEST RESULTS .....	145
5.5	POWER SPECTRAL DENSITY MEASUREMENT .....	146
5.5.1	LIMITS OF POWER SPECTRAL DENSITY MEASUREMENT .....	146
5.5.2	TEST INSTRUMENTS.....	146
5.5.3	TEST PROCEDURE.....	146
5.5.4	DEVIATION FROM TEST STANDARD.....	147
5.5.5	TEST SETUP.....	147
5.5.6	EUT OPERATING CONDITION.....	147
5.5.7	TEST RESULTS .....	148
5.6	BAND EDGES MEASUREMENT .....	151
5.6.1	LIMITS OF BAND EDGES MEASUREMENT.....	151



**A D T**

5.6.2	TEST INSTRUMENTS.....	151
5.6.3	TEST PROCEDURE.....	152
5.6.4	DEVIATION FROM TEST STANDARD.....	153
5.6.5	EUT OPERATING CONDITION.....	153
5.6.6	TEST RESULTS .....	153
6.	PHOTOGRAPHS OF THE TEST CONFIGURATION.....	163
7.	INFORMATION ON THE TESTING LABORATORIES .....	164
8.	APPENDIX A - MODIFICATIONS RECORDERS FOR ENGINEERING CHANGES TO THE EUT BY THE LAB .....	165



A D T

## 1. CERTIFICATION

**PRODUCT:** FORTIAP-220B

**MODEL NO.:** FAP-220Bxxxxxx (where "x" is "0-9", "A-Z", "-", or blank)

**BRAND:** Fortinet

**APPLICANT:** Fortinet Inc.

**TEST SAMPLE:** ENGINEERING SAMPLE

**TESTED:** Jul. 12 ~ Sep. 24, 2010

**STANDARDS:** FCC Part 15, Subpart C (Section 15.247)

ANSI C63.4-2003

The above equipment (Model: FAP-220B) has been tested by **Bureau Veritas Consumer Products Services (H.K.) Ltd., Taoyuan Branch**, and found compliance with the requirement of the above standards. The test record, data evaluation & Equipment Under Test (EUT) configurations represented herein are true and accurate accounts of the measurements of the sample's EMC characteristics under the conditions specified in this report.

**PREPARED BY** : Andrea Hsia , **DATE:** Sep. 29, 2010  
Andrea Hsia / Specialist

**TECHNICAL ACCEPTANCE** : Long Chen , **DATE:** Sep. 29, 2010  
Responsible for RF Long Chen / Senior Engineer

**APPROVED BY** : Gary Chang , **DATE:** Sep. 29, 2010  
Gary Chang / Assistant Manager



A D T

## 2. SUMMARY OF TEST RESULTS

The EUT has been tested according to the following specifications:

APPLIED STANDARD: FCC PART 15, SUBPART C (SECTION 15.247)			
STANDARD SECTION	TEST TYPE AND LIMIT	RESULT	REMARK
15.207	AC Power Conducted Emission	PASS	Meet the requirement of limit. Minimum passing margin is -1.00dB at 29.128MHz
15.247(a)(2)	Spectrum Bandwidth of a Direct Sequence Spread Spectrum System Limit: min. 500kHz	PASS	Meet the requirement of limit.
15.247(b)	Maximum Peak Output Power Limit: max. 30dBm	PASS	Meet the requirement of limit.
15.247(d)	Radiated Emissions Limit: Table 15.209	PASS	Meet the requirement of limit. Minimum passing margin is -1.0dB at 35.83, 45.45, 47.41, 2287.00, 2376.00, 2386.00, 2390.00, 2483.50, 2488.00, 11570.00 & 11650.00MHz
15.247(e)	Power Spectral Density Limit: max. 8dBm	PASS	Meet the requirement of limit.
15.247(d)	Band Edge Measurement Limit: 20dB less than the peak value of fundamental frequency	PASS	Meet the requirement of limit.
15.203	Antenna Requirement	PASS	Antenna connector is UFL not a standard connector.

### 2.1 MEASUREMENT UNCERTAINTY

Where relevant, the following measurement uncertainty levels have been estimated for tests performed on the EUT as specified in CISPR 16-4-2:

MEASUREMENT	FREQUENCY	UNCERTAINTY
Conducted emissions	9kHz~30MHz	2.44 dB
Radiated emissions	30MHz ~ 200MHz	3.19 dB
	200MHz ~1000MHz	3.21 dB
	1GHz ~ 18GHz	2.26 dB
	18GHz ~ 40GHz	1.94 dB

This uncertainty represents an expanded uncertainty expressed at approximately the 95% confidence level using a coverage factor of  $k = 2$ .



### 3. GENERAL INFORMATION

#### 3.1 GENERAL DESCRIPTION OF EUT

<b>PRODUCT</b>	FORTIAP-220B
<b>MODEL NO.</b>	FAP-220Bxxxxxx (where "x" is "0-9", "A-Z", "-", or blank)
<b>FCC ID</b>	TVE-220102
<b>NOMINAL VOLTAGE</b>	12Vdc (from adapter) 48Vdc (from POE)
<b>MODULATION TYPE</b>	CCK, DQPSK, DBPSK for DSSS 64QAM, 16QAM, QPSK, BPSK for OFDM
<b>MODULATION TECHNOLOGY</b>	DSSS, OFDM
<b>TRANSFER RATE</b>	802.11b: 11.0/ 5.5/ 2.0/ 1.0Mbps 802.11g: 54.0/ 48.0/ 36.0/ 24.0/ 18.0/ 12.0/ 9.0/ 6.0Mbps 802.11a: 54.0/ 48.0/ 36.0/ 24.0/ 18.0/ 12.0/ 9.0/ 6.0Mbps 802.11n: up to 300.0Mbps
<b>OPERATING FREQUENCY</b>	2.4GHz: 2412.0 ~ 2462.0MHz 5.0GHz: 5745.0 ~ 5825.0MHz
<b>NUMBER OF CHANNEL</b>	2.4GHz: 11 for 802.11b, 802.11g, 802.11n (20MHz) 7 for 802.11n (40MHz) 5.0GHz: 5 for 802.11a, 802.11n (20MHz) 2 for 802.11n (40MHz)
<b>OUTPUT POWER</b>	514.6mW for 2412.0 ~ 2462.0MHz 594.7mW for 5745.0 ~ 5825.0MHz
<b>ANTENNA TYPE</b>	Refer to Note as below
<b>ANTENNA CONNECTER</b>	Refer to Note as below
<b>DATA CABLE</b>	NA
<b>I/O PORTS</b>	Refer to user's manual
<b>ACCESSORY DEVICES</b>	Adapter

**NOTE:**

1. All models are electrically identical, different model names are for marketing purpose.

BRAND	MODEL
Fortinet	FAP-220Bxxxxxx(where "x" is "0-9", "A-Z", "-", or blank)

2. The EUT is a FORTIAP-220B. The test data are separated into following test reports.

	TEST STANDARD	REFERENCE REPORT
WLAN 802.11b/g, 802.11n	FCC Part 15, Subpart C (Section 15.247)	RF990701C15
WLAN 802.11a, 802.11n (5745~5825 MHz)		
WLAN 802.11a, 802.11n (5180~ 5240MHz)	FCC Part 15, Subpart E (Section 15.407)	RF990701C15-1

3. The frequency bands used in this EUT are listed as follows:

Frequency Band (MHz)	2412~2462	5180~5240	5745~5825
802.11b	√		
802.11g	√		
802.11a		√	√
802.11n (20MHz)	√	√	√
802.11n (40MHz)	√	√	√

4. The EUT incorporates a MIMO function. Physically, the EUT provides two completed transmitters and two receivers.

MODULATION MODE	TX FUNCTION
802.11b	2TX
802.11g	2TX
802.11a	2TX
802.11n (20MHz)	2TX
802.11n (40MHz)	2TX

5. The EUT were powered by the following adapter & POE:

<b>BRAND:</b>	LEADER ELECTRONICS INC.
<b>MODEL:</b>	MU18-D120150-A1
<b>INPUT:</b>	100-240Vac, 50-60Hz, 0.6A
<b>OUTPUT:</b>	12Vdc, 1.5A
<b>POWER LINE:</b>	1.5m non-shielded cable without core

POE	
<b>BRAND</b>	Microsemi
<b>MODEL NO</b>	PD-3001GB/AC
<b>INPUT POWER</b>	100-250Vac, 0.5A, 50/60Hz
<b>OUTPUT POWER</b>	48Vdc, 0.35A

\*\*POE is only for option accessory.

6. There are two radio chipsets for the EUT as below.

RADIO CHIPSET	MODEL	REMARK
1st Radio Chipset	Atheros AR9220	with 5G & 2.4G
2nd Radio Chipset	Atheros AR9223	2.4G only

7. The antennas used in this EUT are listed as below table:

NO.	TYPE	2.4G GAIN	5.0G GAIN	ANTENNA CONNECTOR	REMARK
1	PIFA	0.7dBi	-	UFL	With 2nd Radio Chipset (Atheros-AR9223)
2	PCB	3.9dBi	-	UFL	With 2nd Radio Chipset (Atheros-AR9223)
3	PIFA	2.42dBi	3.14dBi@5.00GHz 3.15dBi@5.86GHz	UFL	With 1st Radio Chipset (Atheros-AR9220)
4	PCB	4.31dBi	4.52dBi@5.2GHz 6.55dBi@5.8GHz	UFL	With 1st Radio Chipset (Atheros-AR9220)

8. The above EUT information was declared by manufacturer and for more detailed features description, please refer to the manufacturer's specifications or user's manual.





### 3.2 DESCRIPTION OF TEST MODES

#### FOR 2.4GHz:

11 channels are provided for 802.11b, 802.11g and 802.11n (20MHz):

CHANNEL	FREQUENCY	CHANNEL	FREQUENCY
1	2412MHz	7	2442MHz
2	2417MHz	8	2447MHz
3	2422MHz	9	2452MHz
4	2427MHz	10	2457MHz
5	2432MHz	11	2462MHz
6	2437MHz		

7 channels are provided for 802.11n (40MHz):

CHANNEL	FREQUENCY	CHANNEL	FREQUENCY
1	2422MHz	5	2442MHz
2	2427MHz	6	2447MHz
3	2432MHz	7	2452MHz
4	2437MHz		

#### FOR 5.0GHz (5725 ~ 5850MHz):

5 channels are provided for 802.11a and 802.11n (20MHz):

CHANNEL	FREQUENCY	CHANNEL	FREQUENCY
149	5745MHz	161	5805MHz
153	5765MHz	165	5825MHz
157	5785MHz		

2 channels are provided for 802.11n (40MHz):

CHANNEL	FREQUENCY	CHANNEL	FREQUENCY
151	5755MHz	159	5795MHz

### 3.2.1 CONFIGURATION OF SYSTEM UNDER TEST

#### FOR ADAPTER MODE

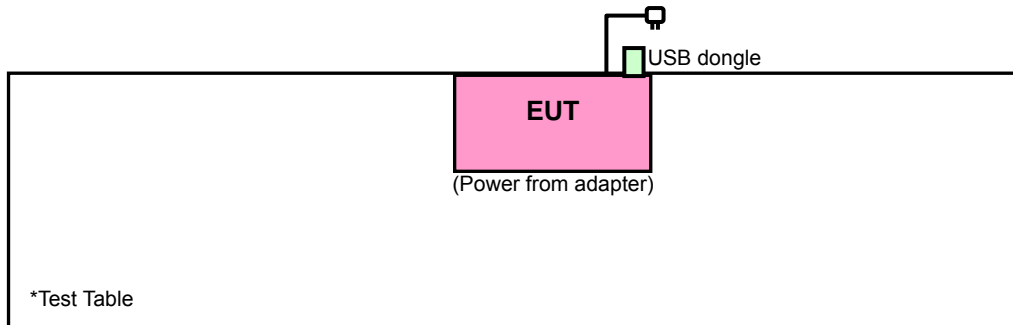

#### FOR POE MODE

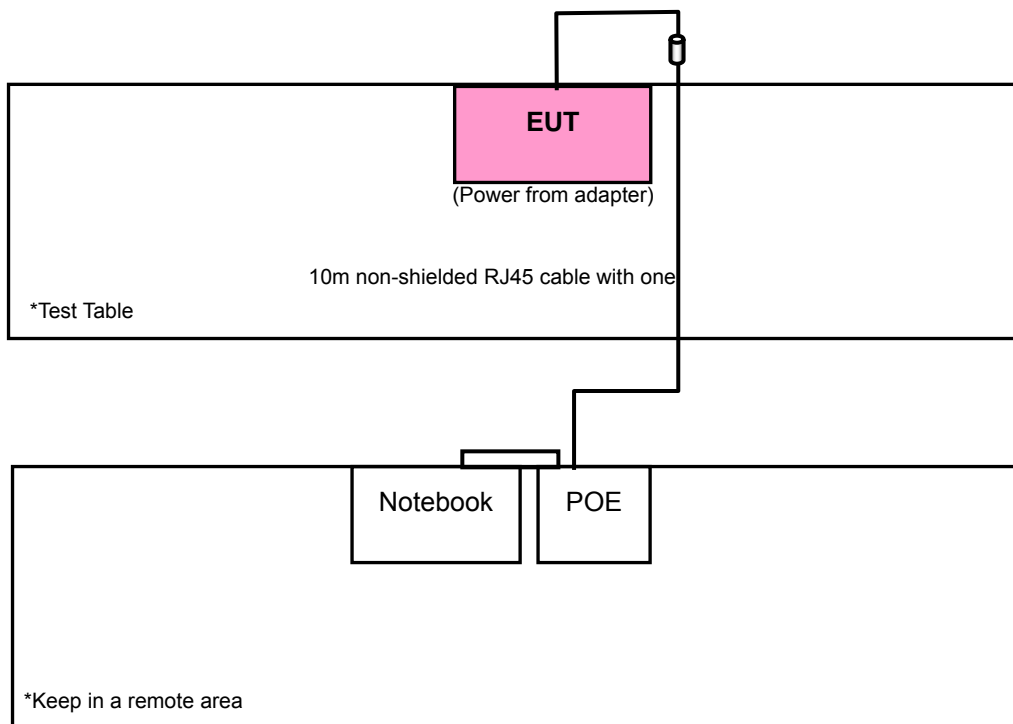



### 3.2.2 TEST MODE APPLICABILITY AND TESTED CHANNEL DETAIL FOR 2.400 ~ 2.4835GHz:

EUT CONFIGURE MODE	APPLICABLE TO				DESCRIPTION
	RE≥1G	RE<1G	PLC	APCM	
A	√	√	√	√	EUT with 1st radio chipset & power from adapter
B	-	√	√	-	EUT with 1st radio chipset & power from POE
C	√	√	√	√	EUT with 2nd radio chipset & power from adapter
D	-	√	√	-	EUT with 2nd radio chipset & power from POE

Where **RE≥1G**: Radiated Emission above 1GHz  
**PLC**: Power Line Conducted Emission  
**NOTE**: "-" means no effect. **RE<1G**: Radiated Emission below 1GHz  
**APCM**: Antenna Port Conducted Measurement

#### **RADIATED EMISSION TEST (ABOVE 1GHz):**

- Pre-Scan has been conducted to determine the worst-case mode from all possible combinations between available modulations, data rates, XYZ axis and antenna ports (if EUT with antenna diversity architecture).
- Following channel(s) was (were) selected for the final test as listed below.

EUT CONFIGURE MODE	MODE	AVAILABLE CHANNEL	TESTED CHANNEL	MODULATION TECHNOLOGY	MODULATION TYPE	DATA RATE (Mbps)	AXIS
A & C	802.11b	1 to 11	1, 6, 11	DSSS	DBPSK	1.0	X
	802.11g	1 to 11	1, 6, 11	OFDM	BPSK	6.0	X
	802.11n (20MHz)	1 to 11	1, 6, 11	OFDM	BPSK	7.2	X
	802.11n (40MHz)	1 to 7	1, 4, 7	OFDM	BPSK	15.0	X

#### **RADIATED EMISSION TEST (BELOW 1GHz):**

- Pre-Scan has been conducted to determine the worst-case mode from all possible combinations between available modulations, data rates, XYZ axis and antenna ports (if EUT with antenna diversity architecture).
- Following channel(s) was (were) selected for the final test as listed below.

EUT CONFIGURE MODE	MODE	AVAILABLE CHANNEL	TESTED CHANNEL	MODULATION TECHNOLOGY	MODULATION TYPE	DATA RATE (Mbps)	AXIS
A & B	802.11b	1 to 11	6	DSSS	DBPSK	1.0	X
C & D	802.11g	1 to 11	6	OFDM	BPSK	6.0	X

#### **POWER LINE CONDUCTED EMISSION TEST:**

- Pre-Scan has been conducted to determine the worst-case mode from all possible combinations between available modulations, data rates and antenna ports (if EUT with antenna diversity architecture).
- Following channel(s) was (were) selected for the final test as listed below.

EUT CONFIGURE MODE	MODE	AVAILABLE CHANNEL	TESTED CHANNEL	MODULATION TECHNOLOGY	MODULATION TYPE	DATA RATE (Mbps)
A & B	802.11b	1 to 11	6	DSSS	DBPSK	1.0
C & D	802.11g	1 to 11	6	OFDM	BPSK	6.0

**BANDEDGE MEASUREMENT:**

- Pre-Scan has been conducted to determine the worst-case mode from all possible combinations between available modulations, data rates and antenna ports (if EUT with antenna diversity architecture).
- Following channel(s) was (were) selected for the final test as listed below.

EUT CONFIGURE MODE	MODE	AVAILABLE CHANNEL	TESTED CHANNEL	MODULATION TECHNOLOGY	MODULATION TYPE	DATA RATE (Mbps)
A & C	802.11b	1 to 11	1, 11	DSSS	DBPSK	1.0
	802.11g	1 to 11	1, 11	OFDM	BPSK	6.0
	802.11n (20MHz)	1 to 11	1, 11	OFDM	BPSK	7.2
	802.11n (40MHz)	1 to 7	1, 7	OFDM	BPSK	15.0

**ANTENNA PORT CONDUCTED MEASUREMENT:**

- This item includes all test value of each mode, but only includes spectrum plot of worst value of each mode.
- Pre-Scan has been conducted to determine the worst-case mode from all possible combinations between available modulations, data rates and antenna ports (if EUT with antenna diversity architecture).
- Following channel(s) was (were) selected for the final test as listed below.

EUT CONFIGURE MODE	MODE	AVAILABLE CHANNEL	TESTED CHANNEL	MODULATION TECHNOLOGY	MODULATION TYPE	DATA RATE (Mbps)
A & C	802.11b	1 to 11	1, 6, 11	DSSS	DBPSK	1.0
	802.11g	1 to 11	1, 6, 11	OFDM	BPSK	6.0
	802.11n (20MHz)	1 to 11	1, 6, 11	OFDM	BPSK	7.2
	802.11n (40MHz)	1 to 7	1, 4, 7	OFDM	BPSK	15.0

**TEST CONDITION:**

APPLICABLE TO	ENVIRONMENTAL CONDITIONS	INPUT POWER	TESTED BY
RE $\geq$ 1G	24deg. C, 65%RH, 1020 hPa	120Vac, 60Hz	Sun Lin
RE $<$ 1G	25deg. C, 65%RH, 1008 hPa	120Vac, 60Hz	Sun Lin
PLC	20deg. C, 60%RH, 1020 hPa	120Vac, 60Hz	Match Tsui
APCM	25deg. C, 63%RH, 1020 hPa	120Vac, 60Hz	Match Tsui



A D T

**FOR 5.725 ~ 5.850GHz:**

EUT CONFIGURE MODE	APPLICABLE TO				DESCRIPTION
	RE≥1G	RE<1G	PLC	APCM	
A	√	√	√	√	EUT with 1st radio chipset & power from adapter
B	-	√	√	-	EUT with 1st radio chipset & power from POE

Where **RE≥1G:** Radiated Emission above 1GHz      **RE<1G:** Radiated Emission below 1GHz  
**PLC:** Power Line Conducted Emission      **APCM:** Antenna Port Conducted Measurement  
**NOTE:** “-” means no effect.

**RADIATED EMISSION TEST (ABOVE 1GHz):**

- Pre-Scan has been conducted to determine the worst-case mode from all possible combinations between available modulations, data rates, XYZ axis and antenna ports (if EUT with antenna diversity architecture).
- Following channel(s) was (were) selected for the final test as listed below.

EUT CONFIGURE MODE	MODE	AVAILABLE CHANNEL	TESTED CHANNEL	MODULATION TECHNOLOGY	MODULATION TYPE	DATA RATE (Mbps)	AXIS
A	802.11a	149 to 165	149, 157, 165	OFDM	BPSK	6.0	Z
	802.11n (20MHz)	149 to 165	149, 157, 165	OFDM	BPSK	7.2	Z
	802.11n (40MHz)	151 to 159	151, 159	OFDM	BPSK	15.0	Z

**RADIATED EMISSION TEST (BELOW 1GHz):**

- Pre-Scan has been conducted to determine the worst-case mode from all possible combinations between available modulations, data rates, XYZ axis and antenna ports (if EUT with antenna diversity architecture).
- Following channel(s) was (were) selected for the final test as listed below.

EUT CONFIGURE MODE	MODE	AVAILABLE CHANNEL	TESTED CHANNEL	MODULATION TECHNOLOGY	MODULATION TYPE	DATA RATE (Mbps)	AXIS
A & B	802.11a	149 to 165	157	OFDM	BPSK	6.0	Z

**POWER LINE CONDUCTED EMISSION TEST:**

- Pre-Scan has been conducted to determine the worst-case mode from all possible combinations between available modulations, data rates and antenna ports (if EUT with antenna diversity architecture).
- Following channel(s) was (were) selected for the final test as listed below.

EUT CONFIGURE MODE	MODE	AVAILABLE CHANNEL	TESTED CHANNEL	MODULATION TECHNOLOGY	MODULATION TYPE	DATA RATE (Mbps)
A & B	802.11a	149 to 165	157	OFDM	BPSK	6.0

**BANDEDGE MEASUREMENT:**

- Pre-Scan has been conducted to determine the worst-case mode from all possible combinations between available modulations, data rates and antenna ports (if EUT with antenna diversity architecture).
- Following channel(s) was (were) selected for the final test as listed below.

EUT CONFIGURE MODE	MODE	AVAILABLE CHANNEL	TESTED CHANNEL	MODULATION TECHNOLOGY	MODULATION TYPE	DATA RATE (Mbps)
A	802.11a	149 to 165	149, 165	OFDM	BPSK	6.0
	802.11n (20MHz)	149 to 165	149, 165	OFDM	BPSK	7.2
	802.11n (40MHz)	151 to 159	151, 159	OFDM	BPSK	15.0

**ANTENNA PORT CONDUCTED MEASUREMENT:**

- This item includes all test value of each mode, but only includes spectrum plot of worst value of each mode.
- Pre-Scan has been conducted to determine the worst-case mode from all possible combinations between available modulations, data rates and antenna ports (if EUT with antenna diversity architecture).
- Following channel(s) was (were) selected for the final test as listed below.

EUT CONFIGURE MODE	MODE	AVAILABLE CHANNEL	TESTED CHANNEL	MODULATION TECHNOLOGY	MODULATION TYPE	DATA RATE (Mbps)
A	802.11a	149 to 165	149, 157, 165	OFDM	BPSK	6.0
	802.11n (20MHz)	149 to 165	149, 157, 165	OFDM	BPSK	7.2
	802.11n (40MHz)	151 to 159	151, 159	OFDM	BPSK	15.0

**TEST CONDITION:**

APPLICABLE TO	ENVIRONMENTAL CONDITIONS	INPUT POWER	TESTED BY
RE $\geq$ 1G	28deg. C, 67%RH, 1020 hPa	120Vac, 60Hz	Antony Lee
RE $<$ 1G	25deg. C, 65%RH, 1008 hPa	120Vac, 60Hz	Brad Wu
PLC	20deg. C, 60%RH, 1020 hPa	120Vac, 60Hz	Match Tsui
APCM	25deg. C, 63%RH, 1020 hPa	120Vac, 60Hz	Match Tsui



A D T

### 3.3 GENERAL DESCRIPTION OF APPLIED STANDARDS

The EUT is a RF Product. According to the specifications of the manufacturer, it must comply with the requirements of the following standards:

#### **FCC Part 15, Subpart C (15.247)**

#### **ANSI C63.4-2003**

All test items have been performed and recorded as per the above standards.

**NOTE:** The EUT is also considered as a kind of computer peripheral, because the connection to computer is necessary for typical use. It has been verified to comply with the requirements of FCC Part 15, Subpart B, Class B (DoC). The test report has been issued separately.

### 3.4 DESCRIPTION OF SUPPORT UNITS

The EUT has been tested as an independent unit together with other necessary accessories or support units. The following support units or accessories were used to form a representative test configuration during the tests.

NO.	PRODUCT	BRAND	MODEL NO.	SERIAL NO.	FCC ID
1	USB DONGLE	SANDISK	SDCZ6-1024	NA	NA
2	NOTEBOOK	DELL	PP05L	25191592336	E2K24CLNS
3	CORE	King Core	KCF-100-B	NA	NA

NO.	SIGNAL CABLE DESCRIPTION OF THE ABOVE SUPPORT UNITS
1	NA
2	10m non-shielded RJ45 cable with one core
3	NA

**NOTE:** 1. All power cords of the above support units are non shielded (1.8m).  
2. Item 2 ~ 3 acts as a communication partner to transfer data.  
3. Console cable was supplied from client.



## 4. TEST TYPES AND RESULTS (FOR 2.4GHz BAND)

### 4.1 RADIATED EMISSION MEASUREMENT

#### 4.1.1 LIMITS OF RADIATED EMISSION MEASUREMENT

Emissions radiated outside of the specified bands, shall be according to the general radiated limits in 15.209 as following:

FREQUENCIES (MHz)	FIELD STRENGTH (microvolts/meter)	MEASUREMENT DISTANCE (meters)
0.009 ~ 0.490	2400/F(kHz)	300
0.490 ~ 1.705	24000/F(kHz)	30
1.705 ~ 30.0	30	30
30 ~ 88	100	3
88 ~ 216	150	3
216 ~ 960	200	3
Above 960	500	3

**NOTE:**

1. The lower limit shall apply at the transition frequencies.
2. Emission level (dBuV/m) = 20 log Emission level (uV/m).
3. As shown in 15.35(b), for frequencies above 1000MHz, the field strength limits are based on average detector, however, the peak field strength of any emission shall not exceed the maximum permitted average limits, specified above by more than 20dB under any condition of modulation.





A D T

#### 4.1.2 TEST INSTRUMENTS

DESCRIPTION & MANUFACTURER	MODEL NO.	SERIAL NO.	DATE OF CALIBRATION	DUE DATE OF CALIBRATION
Test Receiver ROHDE & SCHWARZ	ESI7	838496/016	Dec. 29, 2009	Dec. 28, 2010
Spectrum Analyzer ROHDE & SCHWARZ	FSP40	100039	Jan. 11, 2010	Jan. 10, 2011
BILOG Antenna SCHWARZBECK	VULB9168	9168-155	Apr. 28, 2010	Apr. 27, 2011
HORN Antenna SCHWARZBECK	BBHA 9120D	9120D-408	Jan. 05, 2010	Jan. 04, 2011
HORN Antenna SCHWARZBECK	BBHA 9170	BBHA9170242	Dec. 25, 2009	Dec. 24, 2010
Preamplifier Agilent	8449B	3008A01961	Nov. 04, 2009	Nov. 03, 2010
Preamplifier Agilent	8447D	2944A10738	Nov. 04, 2009	Nov. 03, 2010
RF signal cable HUBER+SUHNNER	SUCOFLEX 104	238141/4	May 14, 2010	May 13, 2011
RF signal cable HUBER+SUHNNER	SUCOFLEX 104	12738/6	May 14, 2010	May 13, 2011
Software ADT.	ADT_Radiated_ V7.6.15.9.2	NA	NA	NA
Antenna Tower inn-co GmbH	MA 4000	010303	NA	NA
Antenna Tower Controller inn-co GmbH	CO2000	019303	NA	NA
Turn Table ADT.	TT100.	TT93021704	NA	NA
Turn Table Controller ADT.	SC100.	SC93021704	NA	NA

- NOTE:**
1. The calibration interval of the above test instruments is 12 months and the calibrations are traceable to NML/ROC and NIST/USA.
  2. The test was performed in HwaYa Chamber 4.
  3. The horn antenna and HP preamplifier (model: 8449B) are used only for the measurement of emission frequency above 1GHz if tested.
  4. The FCC Site Registration No. is 988962.
  5. The IC Site Registration No. is IC7450F-4.



A D T

#### 4.1.3 TEST PROCEDURES

- a. The EUT was placed on the top of a rotating table 0.8 meters above the ground at a 3 meters semi-anechoic chamber. The table was rotated 360 degrees to determine the position of the highest radiation.
- b. The EUT was set 3 meters away from the interference-receiving antenna, which was mounted on the top of a variable-height antenna tower.
- c. The antenna is a broadband antenna, and its height is varied from one meter to four meters above the ground to determine the maximum value of the field strength. Both horizontal and vertical polarizations of the antenna are set to make the measurement.
- d. For each suspected emission, the EUT was arranged to its worst case and then the antenna was tuned to heights from 1 meter to 4 meters and the rotatable table was turned from 0 degrees to 360 degrees to find the maximum reading.
- e. The test-receiver system was set to Peak Detect Function and Specified Bandwidth with Maximum Hold Mode.
- f. If the emission level of the EUT in peak mode was lower than the limit specified, then testing could be stopped and the peak values of the EUT would be reported. Otherwise the emissions would be re-tested one by one using peak, quasi-peak or average method as specified and then reported in a data sheet.

**NOTE:**

1. The resolution bandwidth and video bandwidth of test receiver/spectrum analyzer is 120kHz for Quasi-peak detection at frequency below 1GHz.
2. The resolution bandwidth of test receiver/spectrum analyzer is 100kHz and video bandwidth is 300kHz for Peak detection at frequency above 1GHz.
3. The resolution bandwidth of test receiver/spectrum analyzer is 1MHz and the video bandwidth is 10Hz for Average detection (AV) at frequency above 1GHz.
4. All modes of operation were investigated and the worst-case emissions are reported.

#### 4.1.4 DEVIATION FROM TEST STANDARD

No deviation

#### 4.1.5 TEST SETUP

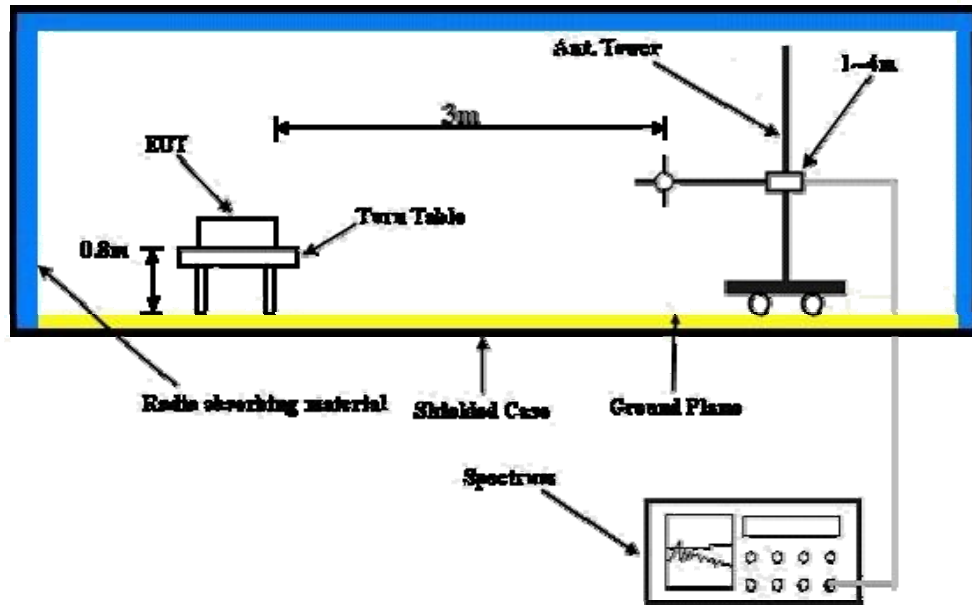

For the actual test configuration, please refer to the attached file (Test Setup Photo).

#### 4.1.6 EUT OPERATING CONDITIONS

- a. Placed the EUT on the testing table and connected to the notebook via RJ45 cable and console cable.
- b. The EUT ran a test program (provided by manufacturer) to enable all functions under transmission condition continuously at specific channel frequency.
- c. The necessary accessories enable the EUT in full functions.



A D T

#### 4.1.7 TEST RESULTS

##### 802.11b

EUT TEST CONDITION		MEASUREMENT DETAIL	
CHANNEL	Channel 1	FREQUENCY RANGE	1 ~ 25GHz
INPUT POWER (SYSTEM)	120Vac, 60 Hz	DETECTOR FUNCTION	Peak (PK) Average (AV)
ENVIRONMENTAL CONDITIONS	24deg. C, 65%RH 1020 hPa	TEST MODE	A
TESTED BY	Sun Lin		

ANTENNA POLARITY & TEST DISTANCE: HORIZONTAL AT 3 M								
NO.	FREQ. (MHz)	EMISSION LEVEL (dBuV/m)	LIMIT (dBuV/m)	MARGIN (dB)	ANTENNA HEIGHT (m)	TABLE ANGLE (Degree)	RAW VALUE (dBuV)	CORRECTION FACTOR (dB/m)
1	2386.00	61.8 PK	74.0	-12.2	1.35 H	125	28.30	33.50
2	2386.00	52.8 AV	54.0	-1.2	1.35 H	125	19.30	33.50
3	*2412.00	111.7 PK			1.35 H	125	78.10	33.60
4	*2412.00	107.1 AV			1.35 H	125	73.50	33.60
5	4824.00	49.3 PK	74.0	-24.7	1.08 H	63	9.30	40.00
6	4824.00	36.9 AV	54.0	-17.1	1.08 H	63	-3.10	40.00
ANTENNA POLARITY & TEST DISTANCE: VERTICAL AT 3 M								
NO.	FREQ. (MHz)	EMISSION LEVEL (dBuV/m)	LIMIT (dBuV/m)	MARGIN (dB)	ANTENNA HEIGHT (m)	TABLE ANGLE (Degree)	RAW VALUE (dBuV)	CORRECTION FACTOR (dB/m)
1	2386.00	61.7 PK	74.0	-12.3	1.46 V	245	28.20	33.50
2	2386.00	51.0 AV	54.0	-3.0	1.46 V	245	17.50	33.50
3	*2412.00	107.8 PK			1.46 V	245	74.20	33.60
4	*2412.00	103.7 AV			1.46 V	245	70.10	33.60
5	4824.00	48.6 PK	74.0	-25.4	1.33 V	278	8.60	40.00
6	4824.00	37.4 AV	54.0	-16.6	1.33 V	278	-2.60	40.00

- REMARKS:**
1. Emission level (dBuV/m) = Raw Value (dBuV) + Correction Factor (dB/m).
  2. Correction Factor (dB/m) = Antenna Factor (dB/m) + Cable Factor (dB).
  3. The other emission levels were very low against the limit.
  4. Margin value = Emission level – Limit value.
  5. “ \* ”: Fundamental frequency.



A D T

EUT TEST CONDITION		MEASUREMENT DETAIL	
CHANNEL	Channel 6	FREQUENCY RANGE	1 ~ 25GHz
INPUT POWER (SYSTEM)	120Vac, 60 Hz	DETECTOR FUNCTION	Peak (PK) Average (AV)
ENVIRONMENTAL CONDITIONS	24deg. C, 65%RH 1020 hPa	TEST MODE	A
TESTED BY	Sun Lin		

ANTENNA POLARITY & TEST DISTANCE: HORIZONTAL AT 3 M								
NO.	FREQ. (MHz)	EMISSION LEVEL (dBuV/m)	LIMIT (dBuV/m)	MARGIN (dB)	ANTENNA HEIGHT (m)	TABLE ANGLE (Degree)	RAW VALUE (dBuV)	CORRECTION FACTOR (dB/m)
1	*2437.00	115.7 PK			1.31 H	106	82.00	33.70
2	*2437.00	111.8 AV			1.31 H	106	78.10	33.70
3	4874.00	50.4 PK	74.0	-23.6	1.25 H	108	10.30	40.10
4	4874.00	38.7 AV	54.0	-15.3	1.25 H	108	-1.40	40.10
ANTENNA POLARITY & TEST DISTANCE: VERTICAL AT 3 M								
NO.	FREQ. (MHz)	EMISSION LEVEL (dBuV/m)	LIMIT (dBuV/m)	MARGIN (dB)	ANTENNA HEIGHT (m)	TABLE ANGLE (Degree)	RAW VALUE (dBuV)	CORRECTION FACTOR (dB/m)
1	*2437.00	110.6 PK			1.00 V	262	76.90	33.70
2	*2437.00	105.9 AV			1.00 V	262	72.20	33.70
3	4874.00	48.3 PK	74.0	-25.7	1.00 V	314	8.20	40.10
4	4874.00	36.4 AV	54.0	-17.6	1.00 V	314	-3.70	40.10

- REMARKS:**
1. Emission level (dBuV/m) = Raw Value (dBuV) + Correction Factor (dB/m).
  2. Correction Factor (dB/m) = Antenna Factor (dB/m) + Cable Factor (dB).
  3. The other emission levels were very low against the limit.
  4. Margin value = Emission level – Limit value.
  5. “ \* “: Fundamental frequency.



A D T

EUT TEST CONDITION		MEASUREMENT DETAIL	
CHANNEL	Channel 11	FREQUENCY RANGE	1 ~ 25GHz
INPUT POWER (SYSTEM)	120Vac, 60 Hz	DETECTOR FUNCTION	Peak (PK) Average (AV)
ENVIRONMENTAL CONDITIONS	24deg. C, 65%RH 1020 hPa	TEST MODE	A
TESTED BY	Sun Lin		

ANTENNA POLARITY & TEST DISTANCE: HORIZONTAL AT 3 M								
NO.	FREQ. (MHz)	EMISSION LEVEL (dBuV/m)	LIMIT (dBuV/m)	MARGIN (dB)	ANTENNA HEIGHT (m)	TABLE ANGLE (Degree)	RAW VALUE (dBuV)	CORRECTION FACTOR (dB/m)
1	*2462.00	110.2 PK			1.27 H	117	76.40	33.80
2	*2462.00	106.2 AV			1.27 H	117	72.40	33.80
3	2488.00	61.8 PK	74.0	-12.2	1.27 H	117	27.90	33.90
4	<b>2488.00</b>	<b>53.0 AV</b>	<b>54.0</b>	<b>-1.0</b>	<b>1.27 H</b>	<b>117</b>	<b>19.10</b>	<b>33.90</b>
5	4924.00	50.5 PK	74.0	-23.5	1.08 H	117	10.30	40.20
6	4924.00	38.7 AV	54.0	-15.3	1.08 H	117	-1.50	40.20
ANTENNA POLARITY & TEST DISTANCE: VERTICAL AT 3 M								
NO.	FREQ. (MHz)	EMISSION LEVEL (dBuV/m)	LIMIT (dBuV/m)	MARGIN (dB)	ANTENNA HEIGHT (m)	TABLE ANGLE (Degree)	RAW VALUE (dBuV)	CORRECTION FACTOR (dB/m)
1	*2462.00	107.7 PK			1.00 V	157	73.90	33.80
2	*2462.00	103.5 AV			1.00 V	157	69.70	33.80
3	2488.00	62.1 PK	74.0	-11.9	1.00 V	157	28.20	33.90
4	2488.00	50.8 AV	54.0	-3.2	1.00 V	157	16.90	33.90
5	4924.00	48.2 PK	74.0	-25.8	1.00 V	197	8.00	40.20
6	4924.00	35.8 AV	54.0	-18.2	1.00 V	197	-4.40	40.20

- REMARKS:**
1. Emission level (dBuV/m) = Raw Value (dBuV) + Correction Factor (dB/m).
  2. Correction Factor (dB/m) = Antenna Factor (dB/m) + Cable Factor (dB).
  3. The other emission levels were very low against the limit.
  4. Margin value = Emission level – Limit value.
  5. “ \* “: Fundamental frequency.



A D T

EUT TEST CONDITION		MEASUREMENT DETAIL	
CHANNEL	Channel 1	FREQUENCY RANGE	1 ~ 25GHz
INPUT POWER (SYSTEM)	120Vac, 60 Hz	DETECTOR FUNCTION	Peak (PK) Average (AV)
ENVIRONMENTAL CONDITIONS	24deg. C, 65%RH 1020 hPa	TEST MODE	C
TESTED BY	Sun Lin		

ANTENNA POLARITY & TEST DISTANCE: HORIZONTAL AT 3 M								
NO.	FREQ. (MHz)	EMISSION LEVEL (dBuV/m)	LIMIT (dBuV/m)	MARGIN (dB)	ANTENNA HEIGHT (m)	TABLE ANGLE (Degree)	RAW VALUE (dBuV)	CORRECTION FACTOR (dB/m)
1	2386.00	64.5 PK	74.0	-9.5	1.97 H	294	31.00	33.50
2	<b>2386.00</b>	<b>53.0 AV</b>	<b>54.0</b>	<b>-1.0</b>	<b>1.97 H</b>	<b>294</b>	<b>19.50</b>	<b>33.50</b>
3	*2412.00	115.2 PK			1.97 H	291	81.60	33.60
4	*2412.00	111.2 AV			1.97 H	291	77.60	33.60
5	4824.00	48.8 PK	74.0	-25.2	1.26 H	80	8.80	40.00
6	4824.00	37.3 AV	54.0	-16.7	1.26 H	80	-2.70	40.00

ANTENNA POLARITY & TEST DISTANCE: VERTICAL AT 3 M								
NO.	FREQ. (MHz)	EMISSION LEVEL (dBuV/m)	LIMIT (dBuV/m)	MARGIN (dB)	ANTENNA HEIGHT (m)	TABLE ANGLE (Degree)	RAW VALUE (dBuV)	CORRECTION FACTOR (dB/m)
1	2386.00	63.7 PK	74.0	-10.3	1.61 V	277	30.20	33.50
2	2386.00	52.3 AV	54.0	-1.7	1.61 V	277	18.80	33.50
3	*2412.00	110.9 PK			1.61 V	275	77.30	33.60
4	*2412.00	107.2 AV			1.61 V	275	73.60	33.60
5	4824.00	51.0 PK	74.0	-23.0	1.43 V	30	11.00	40.00
6	4824.00	43.8 AV	54.0	-10.2	1.43 V	30	3.80	40.00

- REMARKS:**
1. Emission level (dBuV/m) = Raw Value (dBuV) + Correction Factor (dB/m).
  2. Correction Factor (dB/m) = Antenna Factor (dB/m) + Cable Factor (dB).
  3. The other emission levels were very low against the limit.
  4. Margin value = Emission level – Limit value.
  5. “ \* “: Fundamental frequency.



A D T

EUT TEST CONDITION		MEASUREMENT DETAIL	
CHANNEL	Channel 6	FREQUENCY RANGE	1 ~ 25GHz
INPUT POWER (SYSTEM)	120Vac, 60 Hz	DETECTOR FUNCTION	Peak (PK) Average (AV)
ENVIRONMENTAL CONDITIONS	24deg. C, 65%RH 1020 hPa	TEST MODE	C
TESTED BY	Sun Lin		

ANTENNA POLARITY & TEST DISTANCE: HORIZONTAL AT 3 M								
NO.	FREQ. (MHz)	EMISSION LEVEL (dBuV/m)	LIMIT (dBuV/m)	MARGIN (dB)	ANTENNA HEIGHT (m)	TABLE ANGLE (Degree)	RAW VALUE (dBuV)	CORRECTION FACTOR (dB/m)
1	*2437.00	116.0 PK			2.03 H	281	82.30	33.70
2	*2437.00	112.3 AV			2.03 H	281	78.60	33.70
3	4874.00	52.6 PK	74.0	-21.4	1.43 H	277	12.50	40.10
4	4874.00	39.0 AV	54.0	-15.0	1.43 H	277	-1.10	40.10
ANTENNA POLARITY & TEST DISTANCE: VERTICAL AT 3 M								
NO.	FREQ. (MHz)	EMISSION LEVEL (dBuV/m)	LIMIT (dBuV/m)	MARGIN (dB)	ANTENNA HEIGHT (m)	TABLE ANGLE (Degree)	RAW VALUE (dBuV)	CORRECTION FACTOR (dB/m)
1	*2437.00	111.3 PK			1.58 V	267	77.60	33.70
2	*2437.00	107.6 AV			1.58 V	267	73.90	33.70
3	4874.00	53.0 PK	74.0	-21.0	1.24 V	117	12.90	40.10
4	4874.00	44.5 AV	54.0	-9.5	1.24 V	117	4.40	40.10

- REMARKS:**
1. Emission level (dBuV/m) = Raw Value (dBuV) + Correction Factor (dB/m).
  2. Correction Factor (dB/m) = Antenna Factor (dB/m) + Cable Factor (dB).
  3. The other emission levels were very low against the limit.
  4. Margin value = Emission level – Limit value.
  5. “ \* “: Fundamental frequency.





A D T

EUT TEST CONDITION		MEASUREMENT DETAIL	
CHANNEL	Channel 11	FREQUENCY RANGE	1 ~ 25GHz
INPUT POWER (SYSTEM)	120Vac, 60 Hz	DETECTOR FUNCTION	Peak (PK) Average (AV)
ENVIRONMENTAL CONDITIONS	24deg. C, 65%RH 1020 hPa	TEST MODE	C
TESTED BY	Sun Lin		

ANTENNA POLARITY & TEST DISTANCE: HORIZONTAL AT 3 M								
NO.	FREQ. (MHz)	EMISSION LEVEL (dBuV/m)	LIMIT (dBuV/m)	MARGIN (dB)	ANTENNA HEIGHT (m)	TABLE ANGLE (Degree)	RAW VALUE (dBuV)	CORRECTION FACTOR (dB/m)
1	*2462.00	113.8 PK			1.97 H	307	80.00	33.80
2	*2462.00	109.9 AV			1.97 H	307	76.10	33.80
3	2483.50	63.7 PK	74.0	-10.3	1.97 H	302	29.90	33.80
4	2483.50	52.9 AV	54.0	-1.1	1.97 H	302	19.10	33.80
5	4924.00	49.8 PK	74.0	-24.2	1.07 H	7	9.60	40.20
6	4924.00	37.3 AV	54.0	-16.7	1.07 H	7	-2.90	40.20
ANTENNA POLARITY & TEST DISTANCE: VERTICAL AT 3 M								
NO.	FREQ. (MHz)	EMISSION LEVEL (dBuV/m)	LIMIT (dBuV/m)	MARGIN (dB)	ANTENNA HEIGHT (m)	TABLE ANGLE (Degree)	RAW VALUE (dBuV)	CORRECTION FACTOR (dB/m)
1	*2462.00	109.7 PK			1.49 V	277	75.90	33.80
2	*2462.00	105.9 AV			1.49 V	277	72.10	33.80
3	2483.50	63.7 PK	74.0	-10.3	1.53 V	277	29.90	33.80
4	2483.50	52.4 AV	54.0	-1.6	1.53 V	277	18.60	33.80
5	4924.00	49.9 PK	74.0	-24.1	1.39 V	28	9.70	40.20
6	4924.00	38.6 AV	54.0	-15.4	1.39 V	28	-1.60	40.20

- REMARKS:**
1. Emission level (dBuV/m) = Raw Value (dBuV) + Correction Factor (dB/m).
  2. Correction Factor (dB/m) = Antenna Factor (dB/m) + Cable Factor (dB).
  3. The other emission levels were very low against the limit.
  4. Margin value = Emission level – Limit value.
  5. “ \* “: Fundamental frequency.



A D T

802.11g

EUT TEST CONDITION		MEASUREMENT DETAIL	
CHANNEL	Channel 1	FREQUENCY RANGE	1 ~ 25GHz
INPUT POWER (SYSTEM)	120Vac, 60 Hz	DETECTOR FUNCTION	Peak (PK) Average (AV)
ENVIRONMENTAL CONDITIONS	24deg. C, 65%RH 1020 hPa	TEST MODE	A
TESTED BY	Sun Lin		

ANTENNA POLARITY & TEST DISTANCE: HORIZONTAL AT 3 M								
NO.	FREQ. (MHz)	EMISSION LEVEL (dBuV/m)	LIMIT (dBuV/m)	MARGIN (dB)	ANTENNA HEIGHT (m)	TABLE ANGLE (Degree)	RAW VALUE (dBuV)	CORRECTION FACTOR (dB/m)
1	2287.00	61.0 PK	74.0	-13.0	1.41 H	124	28.00	33.00
2	2287.00	53.0 AV	54.0	-1.0	1.41 H	124	20.00	33.00
3	2390.00	67.6 PK	74.0	-6.4	1.41 H	124	34.10	33.50
4	2390.00	52.8 AV	54.0	-1.2	1.41 H	124	19.30	33.50
5	*2412.00	111.9 PK			1.36 H	135	78.30	33.60
6	*2412.00	100.3 AV			1.36 H	135	66.70	33.60
7	4824.00	50.2 PK	74.0	-23.8	1.29 H	72	10.20	40.00
8	4824.00	37.1 AV	54.0	-16.9	1.29 H	72	-2.90	40.00
ANTENNA POLARITY & TEST DISTANCE: VERTICAL AT 3 M								
NO.	FREQ. (MHz)	EMISSION LEVEL (dBuV/m)	LIMIT (dBuV/m)	MARGIN (dB)	ANTENNA HEIGHT (m)	TABLE ANGLE (Degree)	RAW VALUE (dBuV)	CORRECTION FACTOR (dB/m)
1	2287.00	58.7 PK	74.0	-15.3	1.61 V	159	25.70	33.00
2	2287.00	50.9 AV	54.0	-3.1	1.61 V	159	17.90	33.00
3	2390.00	59.3 PK	74.0	-14.7	1.61 V	159	25.80	33.50
4	2390.00	49.9 AV	54.0	-4.1	1.61 V	159	16.40	33.50
5	*2412.00	107.5 PK			1.61 V	159	73.90	33.60
6	*2412.00	96.8 AV			1.61 V	159	63.20	33.60
7	4824.00	48.3 PK	74.0	-25.7	1.18 V	71	8.30	40.00
8	4824.00	37.2 AV	54.0	-16.8	1.18 V	71	-2.80	40.00

- REMARKS:**
1. Emission level (dBuV/m) = Raw Value (dBuV) + Correction Factor (dB/m).
  2. Correction Factor (dB/m) = Antenna Factor (dB/m) + Cable Factor (dB).
  3. The other emission levels were very low against the limit.
  4. Margin value = Emission level – Limit value.
  5. “ \* “: Fundamental frequency.



A D T

EUT TEST CONDITION		MEASUREMENT DETAIL	
CHANNEL	Channel 6	FREQUENCY RANGE	1 ~ 25GHz
INPUT POWER (SYSTEM)	120Vac, 60 Hz	DETECTOR FUNCTION	Peak (PK) Average (AV)
ENVIRONMENTAL CONDITIONS	24deg. C, 65%RH 1020 hPa	TEST MODE	A
TESTED BY	Sun Lin		

ANTENNA POLARITY & TEST DISTANCE: HORIZONTAL AT 3 M								
NO.	FREQ. (MHz)	EMISSION LEVEL (dBuV/m)	LIMIT (dBuV/m)	MARGIN (dB)	ANTENNA HEIGHT (m)	TABLE ANGLE (Degree)	RAW VALUE (dBuV)	CORRECTION FACTOR (dB/m)
1	2287.00	58.9 PK	74.0	-15.1	1.42 H	126	25.90	33.00
2	2287.00	53.0 AV	54.0	-1.0	1.42 H	126	20.00	33.00
3	*2437.00	111.9 PK			1.33 H	117	78.20	33.70
4	*2437.00	101.5 AV			1.33 H	117	67.80	33.70
5	4874.00	49.4 PK	74.0	-24.6	1.08 H	127	9.30	40.10
6	4874.00	36.9 AV	54.0	-17.1	1.08 H	127	-3.20	40.10
ANTENNA POLARITY & TEST DISTANCE: VERTICAL AT 3 M								
NO.	FREQ. (MHz)	EMISSION LEVEL (dBuV/m)	LIMIT (dBuV/m)	MARGIN (dB)	ANTENNA HEIGHT (m)	TABLE ANGLE (Degree)	RAW VALUE (dBuV)	CORRECTION FACTOR (dB/m)
1	2288.00	61.6 PK	74.0	-12.4	1.45 V	321	28.60	33.00
2	2288.00	51.6 AV	54.0	-2.4	1.45 V	321	18.60	33.00
3	*2437.00	108.1 PK			1.00 V	267	74.40	33.70
4	*2437.00	97.9 AV			1.00 V	267	64.20	33.70
5	4874.00	49.6 PK	74.0	-24.4	1.00 V	146	9.50	40.10
6	4874.00	36.0 AV	54.0	-18.0	1.00 V	146	-4.10	40.10

- REMARKS:**
1. Emission level (dBuV/m) = Raw Value (dBuV) + Correction Factor (dB/m).
  2. Correction Factor (dB/m) = Antenna Factor (dB/m) + Cable Factor (dB).
  3. The other emission levels were very low against the limit.
  4. Margin value = Emission level – Limit value.
  5. “ \* “: Fundamental frequency.



A D T

EUT TEST CONDITION		MEASUREMENT DETAIL	
CHANNEL	Channel 11	FREQUENCY RANGE	1 ~ 25GHz
INPUT POWER (SYSTEM)	120Vac, 60 Hz	DETECTOR FUNCTION	Peak (PK) Average (AV)
ENVIRONMENTAL CONDITIONS	24deg. C, 65%RH 1020 hPa	TEST MODE	A
TESTED BY	Sun Lin		

ANTENNA POLARITY & TEST DISTANCE: HORIZONTAL AT 3 M								
NO.	FREQ. (MHz)	EMISSION LEVEL (dBuV/m)	LIMIT (dBuV/m)	MARGIN (dB)	ANTENNA HEIGHT (m)	TABLE ANGLE (Degree)	RAW VALUE (dBuV)	CORRECTION FACTOR (dB/m)
1	2287.00	62.1 PK	74.0	-11.9	1.44 H	129	29.10	33.00
2	2287.00	52.5 AV	54.0	-1.5	1.44 H	129	19.50	33.00
3	*2462.00	111.3 PK			1.28 H	115	77.50	33.80
4	*2462.00	99.1 AV			1.28 H	115	65.30	33.80
5	2483.50	68.9 PK	74.0	-5.1	1.28 H	112	35.10	33.80
6	<b>2483.50</b>	<b>53.0 AV</b>	<b>54.0</b>	<b>-1.0</b>	<b>1.28 H</b>	<b>112</b>	<b>19.20</b>	<b>33.80</b>
7	4924.00	49.7 PK	74.0	-24.3	1.02 H	63	9.50	40.20
8	4924.00	37.9 AV	54.0	-16.1	1.02 H	63	-2.30	40.20
ANTENNA POLARITY & TEST DISTANCE: VERTICAL AT 3 M								
NO.	FREQ. (MHz)	EMISSION LEVEL (dBuV/m)	LIMIT (dBuV/m)	MARGIN (dB)	ANTENNA HEIGHT (m)	TABLE ANGLE (Degree)	RAW VALUE (dBuV)	CORRECTION FACTOR (dB/m)
1	2288.00	60.0 PK	74.0	-14.0	1.00 V	126	27.00	33.00
2	2288.00	49.3 AV	54.0	-4.7	1.00 V	126	16.30	33.00
3	*2462.00	107.1 PK			1.00 V	265	73.30	33.80
4	*2462.00	96.4 AV			1.00 V	265	62.60	33.80
5	2483.50	65.4 PK	74.0	-8.6	1.00 V	265	31.60	33.80
6	2483.50	48.8 AV	54.0	-5.2	1.00 V	265	15.00	33.80
7	4924.00	49.2 PK	74.0	-24.8	1.00 V	281	9.00	40.20
8	4924.00	35.4 AV	54.0	-18.6	1.00 V	281	-4.80	40.20

- REMARKS:**
1. Emission level (dBuV/m) = Raw Value (dBuV) + Correction Factor (dB/m).
  2. Correction Factor (dB/m) = Antenna Factor (dB/m) + Cable Factor (dB).
  3. The other emission levels were very low against the limit.
  4. Margin value = Emission level – Limit value.
  5. “ \* “: Fundamental frequency.



A D T

EUT TEST CONDITION		MEASUREMENT DETAIL	
CHANNEL	Channel 1	FREQUENCY RANGE	1 ~ 25GHz
INPUT POWER (SYSTEM)	120Vac, 60 Hz	DETECTOR FUNCTION	Peak (PK) Average (AV)
ENVIRONMENTAL CONDITIONS	24deg. C, 65%RH 1020 hPa	TEST MODE	C
TESTED BY	Sun Lin		

ANTENNA POLARITY & TEST DISTANCE: HORIZONTAL AT 3 M								
NO.	FREQ. (MHz)	EMISSION LEVEL (dBuV/m)	LIMIT (dBuV/m)	MARGIN (dB)	ANTENNA HEIGHT (m)	TABLE ANGLE (Degree)	RAW VALUE (dBuV)	CORRECTION FACTOR (dB/m)
1	2390.00	65.4 PK	74.0	-8.6	2.05 H	277	31.90	33.50
2	<b>2390.00</b>	<b>53.0 AV</b>	<b>54.0</b>	<b>-1.0</b>	<b>2.05 H</b>	<b>277</b>	<b>19.50</b>	<b>33.50</b>
3	*2412.00	112.0 PK			2.05 H	277	78.40	33.60
4	*2412.00	101.8 AV			2.05 H	277	68.20	33.60
5	4824.00	49.7 PK	74.0	-24.3	1.33 H	107	9.70	40.00
6	4824.00	37.2 AV	54.0	-16.8	1.33 H	107	-2.80	40.00
ANTENNA POLARITY & TEST DISTANCE: VERTICAL AT 3 M								
NO.	FREQ. (MHz)	EMISSION LEVEL (dBuV/m)	LIMIT (dBuV/m)	MARGIN (dB)	ANTENNA HEIGHT (m)	TABLE ANGLE (Degree)	RAW VALUE (dBuV)	CORRECTION FACTOR (dB/m)
1	2390.00	63.3 PK	74.0	-10.7	1.58 V	239	29.80	33.50
2	2390.00	52.0 AV	54.0	-2.0	1.58 V	239	18.50	33.50
3	*2412.00	108.5 PK			1.58 V	243	74.90	33.60
4	*2412.00	97.5 AV			1.58 V	243	63.90	33.60
5	4824.00	48.3 PK	74.0	-25.7	1.05 V	237	8.30	40.00
6	4824.00	36.7 AV	54.0	-17.3	1.05 V	237	-3.30	40.00

- REMARKS:**
1. Emission level (dBuV/m) = Raw Value (dBuV) + Correction Factor (dB/m).
  2. Correction Factor (dB/m) = Antenna Factor (dB/m) + Cable Factor (dB).
  3. The other emission levels were very low against the limit.
  4. Margin value = Emission level – Limit value.
  5. “ \* “: Fundamental frequency.



A D T

EUT TEST CONDITION		MEASUREMENT DETAIL	
CHANNEL	Channel 6	FREQUENCY RANGE	1 ~ 25GHz
INPUT POWER (SYSTEM)	120Vac, 60 Hz	DETECTOR FUNCTION	Peak (PK) Average (AV)
ENVIRONMENTAL CONDITIONS	24deg. C, 65%RH 1020 hPa	TEST MODE	C
TESTED BY	Sun Lin		

ANTENNA POLARITY & TEST DISTANCE: HORIZONTAL AT 3 M								
NO.	FREQ. (MHz)	EMISSION LEVEL (dBuV/m)	LIMIT (dBuV/m)	MARGIN (dB)	ANTENNA HEIGHT (m)	TABLE ANGLE (Degree)	RAW VALUE (dBuV)	CORRECTION FACTOR (dB/m)
1	2376.00	63.9 PK	74.0	-10.1	2.03 H	306	30.50	33.40
2	2376.00	52.9 AV	54.0	-1.1	2.03 H	306	19.50	33.40
3	*2437.00	114.3 PK			2.02 H	306	80.60	33.70
4	*2437.00	104.0 AV			2.02 H	306	70.30	33.70
5	4874.00	50.7 PK	74.0	-23.3	1.24 H	118	10.60	40.10
6	4874.00	38.4 AV	54.0	-15.6	1.24 H	118	-1.70	40.10
ANTENNA POLARITY & TEST DISTANCE: VERTICAL AT 3 M								
NO.	FREQ. (MHz)	EMISSION LEVEL (dBuV/m)	LIMIT (dBuV/m)	MARGIN (dB)	ANTENNA HEIGHT (m)	TABLE ANGLE (Degree)	RAW VALUE (dBuV)	CORRECTION FACTOR (dB/m)
1	2376.00	62.0 PK	74.0	-12.0	1.57 V	278	28.60	33.40
2	2376.00	51.9 AV	54.0	-2.1	1.57 V	278	18.50	33.40
3	*2437.00	110.2 PK			1.53 V	279	76.50	33.70
4	*2437.00	100.6 AV			1.53 V	279	66.90	33.70
5	4874.00	48.8 PK	74.0	-25.2	1.01 V	271	8.70	40.10
6	4874.00	37.6 AV	54.0	-16.4	1.01 V	271	-2.50	40.10

- REMARKS:**
1. Emission level (dBuV/m) = Raw Value (dBuV) + Correction Factor (dB/m).
  2. Correction Factor (dB/m) = Antenna Factor (dB/m) + Cable Factor (dB).
  3. The other emission levels were very low against the limit.
  4. Margin value = Emission level – Limit value.
  5. “ \* “: Fundamental frequency.



A D T

EUT TEST CONDITION		MEASUREMENT DETAIL	
CHANNEL	Channel 11	FREQUENCY RANGE	1 ~ 25GHz
INPUT POWER (SYSTEM)	120Vac, 60 Hz	DETECTOR FUNCTION	Peak (PK) Average (AV)
ENVIRONMENTAL CONDITIONS	24deg. C, 65%RH 1020 hPa	TEST MODE	C
TESTED BY	Sun Lin		

ANTENNA POLARITY & TEST DISTANCE: HORIZONTAL AT 3 M								
NO.	FREQ. (MHz)	EMISSION LEVEL (dBuV/m)	LIMIT (dBuV/m)	MARGIN (dB)	ANTENNA HEIGHT (m)	TABLE ANGLE (Degree)	RAW VALUE (dBuV)	CORRECTION FACTOR (dB/m)
1	*2462.00	112.7 PK			2.00 H	304	78.90	33.80
2	*2462.00	102.6 AV			2.00 H	304	68.80	33.80
3	2483.50	69.5 PK	74.0	-4.5	2.00 H	280	35.70	33.80
4	<b>2483.50</b>	<b>53.0 AV</b>	<b>54.0</b>	<b>-1.0</b>	<b>2.00 H</b>	<b>280</b>	<b>19.20</b>	<b>33.80</b>
5	4924.00	49.8 PK	74.0	-24.2	1.38 H	267	9.60	40.20
6	4924.00	38.4 AV	54.0	-15.6	1.38 H	267	-1.80	40.20
ANTENNA POLARITY & TEST DISTANCE: VERTICAL AT 3 M								
NO.	FREQ. (MHz)	EMISSION LEVEL (dBuV/m)	LIMIT (dBuV/m)	MARGIN (dB)	ANTENNA HEIGHT (m)	TABLE ANGLE (Degree)	RAW VALUE (dBuV)	CORRECTION FACTOR (dB/m)
1	*2462.00	109.0 PK			1.52 V	263	75.20	33.80
2	*2462.00	98.1 AV			1.52 V	263	64.30	33.80
3	2483.50	63.5 PK	74.0	-10.5	1.53 V	257	29.70	33.80
4	2483.50	52.2 AV	54.0	-1.8	1.53 V	257	18.40	33.80
5	4924.00	48.5 PK	74.0	-25.5	1.08 V	227	8.30	40.20
6	4924.00	36.9 AV	54.0	-17.1	1.08 V	227	-3.30	40.20

- REMARKS:**
1. Emission level (dBuV/m) = Raw Value (dBuV) + Correction Factor (dB/m).
  2. Correction Factor (dB/m) = Antenna Factor (dB/m) + Cable Factor (dB).
  3. The other emission levels were very low against the limit.
  4. Margin value = Emission level – Limit value.
  5. “ \* “: Fundamental frequency.



A D T

802.11n (20MHz)

EUT TEST CONDITION		MEASUREMENT DETAIL	
CHANNEL	Channel 1	FREQUENCY RANGE	1 ~ 25GHz
INPUT POWER (SYSTEM)	120Vac, 60 Hz	DETECTOR FUNCTION	Peak (PK) Average (AV)
ENVIRONMENTAL CONDITIONS	24deg. C, 65%RH 1020 hPa	TEST MODE	A
TESTED BY	Sun Lin		

ANTENNA POLARITY & TEST DISTANCE: HORIZONTAL AT 3 M								
NO.	FREQ. (MHz)	EMISSION LEVEL (dBuV/m)	LIMIT (dBuV/m)	MARGIN (dB)	ANTENNA HEIGHT (m)	TABLE ANGLE (Degree)	RAW VALUE (dBuV)	CORRECTION FACTOR (dB/m)
1	2287.00	62.3 PK	74.0	-11.7	1.43 H	118	29.30	33.00
2	2287.00	53.0 AV	54.0	-1.0	1.43 H	118	20.00	33.00
3	2390.00	67.1 PK	74.0	-6.9	1.31 H	124	33.60	33.50
4	2390.00	52.9 AV	54.0	-1.1	1.31 H	124	19.40	33.50
5	*2412.00	111.5 PK			1.31 H	125	77.90	33.60
6	*2412.00	99.7 AV			1.31 H	125	66.10	33.60
7	4824.00	49.9 PK	74.0	-24.1	1.07 H	112	9.90	40.00
8	4824.00	37.4 AV	54.0	-16.6	1.07 H	112	-2.60	40.00
ANTENNA POLARITY & TEST DISTANCE: VERTICAL AT 3 M								
NO.	FREQ. (MHz)	EMISSION LEVEL (dBuV/m)	LIMIT (dBuV/m)	MARGIN (dB)	ANTENNA HEIGHT (m)	TABLE ANGLE (Degree)	RAW VALUE (dBuV)	CORRECTION FACTOR (dB/m)
1	2288.00	59.8 PK	74.0	-14.2	1.00 V	159	26.80	33.00
2	2288.00	47.7 AV	54.0	-6.3	1.00 V	159	14.70	33.00
3	2390.00	65.1 PK	74.0	-8.9	1.00 V	263	31.60	33.50
4	2390.00	48.7 AV	54.0	-5.3	1.00 V	263	15.20	33.50
5	*2412.00	106.5 PK			1.00 V	263	72.90	33.60
6	*2412.00	95.3 AV			1.00 V	263	61.70	33.60

- REMARKS:**
1. Emission level (dBuV/m) = Raw Value (dBuV) + Correction Factor (dB/m).
  2. Correction Factor (dB/m) = Antenna Factor (dB/m) + Cable Factor (dB).
  3. The other emission levels were very low against the limit.
  4. Margin value = Emission level – Limit value.
  5. “ \* “: Fundamental frequency.





A D T

EUT TEST CONDITION		MEASUREMENT DETAIL	
CHANNEL	Channel 6	FREQUENCY RANGE	1 ~ 25GHz
INPUT POWER (SYSTEM)	120Vac, 60 Hz	DETECTOR FUNCTION	Peak (PK) Average (AV)
ENVIRONMENTAL CONDITIONS	24deg. C, 65%RH 1020 hPa	TEST MODE	A
TESTED BY	Sun Lin		

ANTENNA POLARITY & TEST DISTANCE: HORIZONTAL AT 3 M								
NO.	FREQ. (MHz)	EMISSION LEVEL (dBuV/m)	LIMIT (dBuV/m)	MARGIN (dB)	ANTENNA HEIGHT (m)	TABLE ANGLE (Degree)	RAW VALUE (dBuV)	CORRECTION FACTOR (dB/m)
1	2287.00	63.5 PK	74.0	-10.5	1.45 H	130	30.50	33.00
2	2287.00	52.3 AV	54.0	-1.7	1.45 H	130	19.30	33.00
3	*2437.00	112.6 PK			1.29 H	121	78.90	33.70
4	*2437.00	101.5 AV			1.29 H	121	67.80	33.70
5	4874.00	49.8 PK	74.0	-24.2	1.27 H	263	9.70	40.10
6	4874.00	37.5 AV	54.0	-16.5	1.27 H	263	-2.60	40.10
ANTENNA POLARITY & TEST DISTANCE: VERTICAL AT 3 M								
NO.	FREQ. (MHz)	EMISSION LEVEL (dBuV/m)	LIMIT (dBuV/m)	MARGIN (dB)	ANTENNA HEIGHT (m)	TABLE ANGLE (Degree)	RAW VALUE (dBuV)	CORRECTION FACTOR (dB/m)
1	2288.00	60.0 PK	74.0	-14.0	1.68 V	156	27.00	33.00
2	2288.00	48.7 AV	54.0	-5.3	1.68 V	156	15.70	33.00
3	*2437.00	107.6 PK			1.00 V	243	73.90	33.70
4	*2437.00	96.6 AV			1.00 V	243	62.90	33.70
5	4874.00	47.9 PK	74.0	-26.1	1.00 V	247	7.80	40.10
6	4874.00	35.8 AV	54.0	-18.2	1.00 V	247	-4.30	40.10

- REMARKS:**
1. Emission level (dBuV/m) = Raw Value (dBuV) + Correction Factor (dB/m).
  2. Correction Factor (dB/m) = Antenna Factor (dB/m) + Cable Factor (dB).
  3. The other emission levels were very low against the limit.
  4. Margin value = Emission level – Limit value.
  5. “ \* “: Fundamental frequency.



A D T

EUT TEST CONDITION		MEASUREMENT DETAIL	
CHANNEL	Channel 11	FREQUENCY RANGE	1 ~ 25GHz
INPUT POWER (SYSTEM)	120Vac, 60 Hz	DETECTOR FUNCTION	Peak (PK) Average (AV)
ENVIRONMENTAL CONDITIONS	24deg. C, 65%RH 1020 hPa	TEST MODE	A
TESTED BY	Sun Lin		

ANTENNA POLARITY & TEST DISTANCE: HORIZONTAL AT 3 M								
NO.	FREQ. (MHz)	EMISSION LEVEL (dBuV/m)	LIMIT (dBuV/m)	MARGIN (dB)	ANTENNA HEIGHT (m)	TABLE ANGLE (Degree)	RAW VALUE (dBuV)	CORRECTION FACTOR (dB/m)
1	2287.00	61.3 PK	74.0	-12.7	1.44 H	129	28.30	33.00
2	2287.00	52.0 AV	54.0	-2.0	1.44 H	129	19.00	33.00
3	*2462.00	109.6 PK			1.30 H	125	75.80	33.80
4	*2462.00	98.3 AV			1.30 H	125	64.50	33.80
5	2483.50	70.2 PK	74.0	-3.8	1.26 H	105	36.40	33.80
6	<b>2483.50</b>	<b>53.0 AV</b>	<b>54.0</b>	<b>-1.0</b>	<b>1.26 H</b>	<b>105</b>	<b>19.20</b>	<b>33.80</b>
7	4924.00	49.7 PK	74.0	-24.3	1.37 H	288	9.50	40.20
8	4924.00	37.2 AV	54.0	-16.8	1.37 H	288	-3.00	40.20
ANTENNA POLARITY & TEST DISTANCE: VERTICAL AT 3 M								
NO.	FREQ. (MHz)	EMISSION LEVEL (dBuV/m)	LIMIT (dBuV/m)	MARGIN (dB)	ANTENNA HEIGHT (m)	TABLE ANGLE (Degree)	RAW VALUE (dBuV)	CORRECTION FACTOR (dB/m)
1	2288.00	61.4 PK	74.0	-12.6	1.00 V	246	28.40	33.00
2	2288.00	49.8 AV	54.0	-4.2	1.00 V	246	16.80	33.00
3	*2462.00	105.7 PK			1.00 V	153	71.90	33.80
4	*2462.00	94.5 AV			1.00 V	153	60.70	33.80
5	2483.50	64.8 PK	74.0	-9.2	1.00 V	153	31.00	33.80
6	2483.50	50.0 AV	54.0	-4.0	1.00 V	153	16.20	33.80
7	4924.00	47.3 PK	74.0	-26.7	1.10 V	243	7.10	40.20
8	4924.00	35.4 AV	54.0	-18.6	1.10 V	243	-4.80	40.20

- REMARKS:**
1. Emission level (dBuV/m) = Raw Value (dBuV) + Correction Factor (dB/m).
  2. Correction Factor (dB/m) = Antenna Factor (dB/m) + Cable Factor (dB).
  3. The other emission levels were very low against the limit.
  4. Margin value = Emission level – Limit value.
  5. “ \* “: Fundamental frequency.



A D T

EUT TEST CONDITION		MEASUREMENT DETAIL	
CHANNEL	Channel 1	FREQUENCY RANGE	1 ~ 25GHz
INPUT POWER (SYSTEM)	120Vac, 60 Hz	DETECTOR FUNCTION	Peak (PK) Average (AV)
ENVIRONMENTAL CONDITIONS	24deg. C, 65%RH 1020 hPa	TEST MODE	C
TESTED BY	Sun Lin		

ANTENNA POLARITY & TEST DISTANCE: HORIZONTAL AT 3 M								
NO.	FREQ. (MHz)	EMISSION LEVEL (dBuV/m)	LIMIT (dBuV/m)	MARGIN (dB)	ANTENNA HEIGHT (m)	TABLE ANGLE (Degree)	RAW VALUE (dBuV)	CORRECTION FACTOR (dB/m)
1	2390.00	70.5 PK	74.0	-3.5	1.98 H	272	37.00	33.50
2	2390.00	53.0 AV	54.0	-1.0	1.98 H	272	19.50	33.50
3	*2412.00	111.2 PK			1.92 H	267	77.60	33.60
4	*2412.00	100.2 AV			1.92 H	267	66.60	33.60
5	4824.00	49.9 PK	74.0	-24.1	1.32 H	73	9.90	40.00
6	4824.00	37.2 AV	54.0	-16.8	1.32 H	73	-2.80	40.00

ANTENNA POLARITY & TEST DISTANCE: VERTICAL AT 3 M								
NO.	FREQ. (MHz)	EMISSION LEVEL (dBuV/m)	LIMIT (dBuV/m)	MARGIN (dB)	ANTENNA HEIGHT (m)	TABLE ANGLE (Degree)	RAW VALUE (dBuV)	CORRECTION FACTOR (dB/m)
1	2390.00	67.7 PK	74.0	-6.3	1.65 V	278	34.20	33.50
2	2390.00	52.1 AV	54.0	-1.9	1.65 V	278	18.60	33.50
3	*2412.00	107.2 PK			1.65 V	271	73.60	33.60
4	*2412.00	96.7 AV			1.65 V	271	63.10	33.60
5	4824.00	48.1 PK	74.0	-25.9	1.07 V	233	8.10	40.00
6	4824.00	36.4 AV	54.0	-17.6	1.07 V	233	-3.60	40.00

- REMARKS:**
1. Emission level (dBuV/m) = Raw Value (dBuV) + Correction Factor (dB/m).
  2. Correction Factor (dB/m) = Antenna Factor (dB/m) + Cable Factor (dB).
  3. The other emission levels were very low against the limit.
  4. Margin value = Emission level – Limit value.
  5. “ \* “: Fundamental frequency.



A D T

EUT TEST CONDITION		MEASUREMENT DETAIL	
CHANNEL	Channel 6	FREQUENCY RANGE	1 ~ 25GHz
INPUT POWER (SYSTEM)	120Vac, 60 Hz	DETECTOR FUNCTION	Peak (PK) Average (AV)
ENVIRONMENTAL CONDITIONS	24deg. C, 65%RH 1020 hPa	TEST MODE	C
TESTED BY	Sun Lin		

ANTENNA POLARITY & TEST DISTANCE: HORIZONTAL AT 3 M								
NO.	FREQ. (MHz)	EMISSION LEVEL (dBuV/m)	LIMIT (dBuV/m)	MARGIN (dB)	ANTENNA HEIGHT (m)	TABLE ANGLE (Degree)	RAW VALUE (dBuV)	CORRECTION FACTOR (dB/m)
1	2376.00	63.8 PK	74.0	-10.2	2.01 H	305	30.40	33.40
2	<b>2376.00</b>	<b>53.0 AV</b>	<b>54.0</b>	<b>-1.0</b>	<b>2.01 H</b>	<b>305</b>	<b>19.60</b>	<b>33.40</b>
3	*2437.00	113.1 PK			2.01 H	300	79.40	33.70
4	*2437.00	103.3 AV			2.01 H	300	69.60	33.70
5	4874.00	50.4 PK	74.0	-23.6	1.22 H	241	10.30	40.10
6	4874.00	38.6 AV	54.0	-15.4	1.22 H	241	-1.50	40.10

ANTENNA POLARITY & TEST DISTANCE: VERTICAL AT 3 M								
NO.	FREQ. (MHz)	EMISSION LEVEL (dBuV/m)	LIMIT (dBuV/m)	MARGIN (dB)	ANTENNA HEIGHT (m)	TABLE ANGLE (Degree)	RAW VALUE (dBuV)	CORRECTION FACTOR (dB/m)
1	2376.00	61.7 PK	74.0	-12.3	1.58 V	268	28.30	33.40
2	2376.00	51.8 AV	54.0	-2.2	1.58 V	268	18.40	33.40
3	*2437.00	109.5 PK			1.63 V	257	75.80	33.70
4	*2437.00	99.7 AV			1.63 V	257	66.00	33.70
5	4874.00	48.3 PK	74.0	-25.7	1.09 V	115	8.20	40.10
6	4874.00	37.5 AV	54.0	-16.5	1.09 V	115	-2.60	40.10

- REMARKS:**
1. Emission level (dBuV/m) = Raw Value (dBuV) + Correction Factor (dB/m).
  2. Correction Factor (dB/m) = Antenna Factor (dB/m) + Cable Factor (dB).
  3. The other emission levels were very low against the limit.
  4. Margin value = Emission level – Limit value.
  5. “ \* “: Fundamental frequency.



A D T

EUT TEST CONDITION		MEASUREMENT DETAIL	
CHANNEL	Channel 11	FREQUENCY RANGE	1 ~ 25GHz
INPUT POWER (SYSTEM)	120Vac, 60 Hz	DETECTOR FUNCTION	Peak (PK) Average (AV)
ENVIRONMENTAL CONDITIONS	24deg. C, 65%RH 1020 hPa	TEST MODE	C
TESTED BY	Sun Lin		

ANTENNA POLARITY & TEST DISTANCE: HORIZONTAL AT 3 M								
NO.	FREQ. (MHz)	EMISSION LEVEL (dBuV/m)	LIMIT (dBuV/m)	MARGIN (dB)	ANTENNA HEIGHT (m)	TABLE ANGLE (Degree)	RAW VALUE (dBuV)	CORRECTION FACTOR (dB/m)
1	*2462.00	111.8 PK			1.98 H	266	78.00	33.80
2	*2462.00	100.8 AV			1.98 H	266	67.00	33.80
3	2483.50	67.2 PK	74.0	-6.8	1.90 H	267	33.40	33.80
4	<b>2483.50</b>	<b>53.0 AV</b>	<b>54.0</b>	<b>-1.0</b>	<b>1.90 H</b>	<b>267</b>	<b>19.20</b>	<b>33.80</b>
5	4924.00	49.9 PK	74.0	-24.1	1.25 H	53	9.70	40.20
6	4924.00	37.8 AV	54.0	-16.2	1.25 H	53	-2.40	40.20
ANTENNA POLARITY & TEST DISTANCE: VERTICAL AT 3 M								
NO.	FREQ. (MHz)	EMISSION LEVEL (dBuV/m)	LIMIT (dBuV/m)	MARGIN (dB)	ANTENNA HEIGHT (m)	TABLE ANGLE (Degree)	RAW VALUE (dBuV)	CORRECTION FACTOR (dB/m)
1	*2462.00	107.5 PK			1.58 V	277	73.70	33.80
2	*2462.00	97.3 AV			1.58 V	277	63.50	33.80
3	2483.50	67.5 PK	74.0	-6.5	1.60 V	271	33.70	33.80
4	2483.50	52.0 AV	54.0	-2.0	1.60 V	271	18.20	33.80
5	4924.00	48.3 PK	74.0	-25.7	1.22 V	217	8.10	40.20
6	4924.00	36.5 AV	54.0	-17.5	1.22 V	217	-3.70	40.20

- REMARKS:**
1. Emission level (dBuV/m) = Raw Value (dBuV) + Correction Factor (dB/m).
  2. Correction Factor (dB/m) = Antenna Factor (dB/m) + Cable Factor (dB).
  3. The other emission levels were very low against the limit.
  4. Margin value = Emission level – Limit value.
  5. “ \* “: Fundamental frequency.



A D T

802.11n (40MHz)

EUT TEST CONDITION		MEASUREMENT DETAIL	
CHANNEL	Channel 1	FREQUENCY RANGE	1 ~ 25GHz
INPUT POWER (SYSTEM)	120Vac, 60 Hz	DETECTOR FUNCTION	Peak (PK) Average (AV)
ENVIRONMENTAL CONDITIONS	24deg. C, 65%RH 1020 hPa	TEST MODE	A
TESTED BY	Sun Lin		

ANTENNA POLARITY & TEST DISTANCE: HORIZONTAL AT 3 M								
NO.	FREQ. (MHz)	EMISSION LEVEL (dBuV/m)	LIMIT (dBuV/m)	MARGIN (dB)	ANTENNA HEIGHT (m)	TABLE ANGLE (Degree)	RAW VALUE (dBuV)	CORRECTION FACTOR (dB/m)
1	2390.00	70.9 PK	74.0	-3.1	1.34 H	123	37.40	33.50
2	2390.00	53.0 AV	54.0	-1.0	1.34 H	123	19.50	33.50
3	*2422.00	103.2 PK			1.34 H	123	69.60	33.60
4	*2422.00	93.4 AV			1.34 H	123	59.80	33.60
5	4844.00	49.8 PK	74.0	-24.2	1.27 H	225	9.80	40.00
6	4844.00	37.3 AV	54.0	-16.7	1.27 H	225	-2.70	40.00
ANTENNA POLARITY & TEST DISTANCE: VERTICAL AT 3 M								
NO.	FREQ. (MHz)	EMISSION LEVEL (dBuV/m)	LIMIT (dBuV/m)	MARGIN (dB)	ANTENNA HEIGHT (m)	TABLE ANGLE (Degree)	RAW VALUE (dBuV)	CORRECTION FACTOR (dB/m)
1	2390.00	63.0 PK	74.0	-11.0	1.00 V	262	29.50	33.50
2	2390.00	50.3 AV	54.0	-3.7	1.00 V	262	16.80	33.50
3	*2422.00	98.3 PK			1.00 V	262	64.70	33.60
4	*2422.00	88.5 AV			1.00 V	262	54.90	33.60
5	4844.00	47.5 PK	74.0	-26.5	1.00 V	179	7.50	40.00
6	4844.00	34.9 AV	54.0	-19.1	1.00 V	179	-5.10	40.00

- REMARKS:**
1. Emission level (dBuV/m) = Raw Value (dBuV) + Correction Factor (dB/m).
  2. Correction Factor (dB/m) = Antenna Factor (dB/m) + Cable Factor (dB).
  3. The other emission levels were very low against the limit.
  4. Margin value = Emission level – Limit value.
  5. “ \* “: Fundamental frequency.



A D T

EUT TEST CONDITION		MEASUREMENT DETAIL	
CHANNEL	Channel 4	FREQUENCY RANGE	1 ~ 25GHz
INPUT POWER (SYSTEM)	120Vac, 60 Hz	DETECTOR FUNCTION	Peak (PK) Average (AV)
ENVIRONMENTAL CONDITIONS	24deg. C, 65%RH 1020 hPa	TEST MODE	A
TESTED BY	Sun Lin		

ANTENNA POLARITY & TEST DISTANCE: HORIZONTAL AT 3 M								
NO.	FREQ. (MHz)	EMISSION LEVEL (dBuV/m)	LIMIT (dBuV/m)	MARGIN (dB)	ANTENNA HEIGHT (m)	TABLE ANGLE (Degree)	RAW VALUE (dBuV)	CORRECTION FACTOR (dB/m)
1	*2437.00	106.5 PK			1.32 H	122	72.80	33.70
2	*2437.00	96.7 AV			1.32 H	122	63.00	33.70
3	2483.50	65.5 PK	74.0	-8.5	1.26 H	104	31.70	33.80
4	<b>2483.50</b>	<b>53.0 AV</b>	<b>54.0</b>	<b>-1.0</b>	<b>1.26 H</b>	<b>104</b>	<b>19.20</b>	<b>33.80</b>
5	4874.00	49.1 PK	74.0	-24.9	1.17 H	247	9.00	40.10
6	4874.00	37.4 AV	54.0	-16.6	1.17 H	247	-2.70	40.10
ANTENNA POLARITY & TEST DISTANCE: VERTICAL AT 3 M								
NO.	FREQ. (MHz)	EMISSION LEVEL (dBuV/m)	LIMIT (dBuV/m)	MARGIN (dB)	ANTENNA HEIGHT (m)	TABLE ANGLE (Degree)	RAW VALUE (dBuV)	CORRECTION FACTOR (dB/m)
1	*2437.00	101.6 PK			1.00 V	263	67.90	33.70
2	*2437.00	91.9 AV			1.00 V	263	58.20	33.70
3	2483.50	62.7 PK	74.0	-11.3	1.00 V	56	28.90	33.80
4	2483.50	50.1 AV	54.0	-3.9	1.00 V	56	16.30	33.80
5	4874.00	47.6 PK	74.0	-26.4	1.00 V	56	7.50	40.10
6	4874.00	35.1 AV	54.0	-18.9	1.00 V	56	-5.00	40.10

- REMARKS:**
1. Emission level (dBuV/m) = Raw Value (dBuV) + Correction Factor (dB/m).
  2. Correction Factor (dB/m) = Antenna Factor (dB/m) + Cable Factor (dB).
  3. The other emission levels were very low against the limit.
  4. Margin value = Emission level – Limit value.
  5. “ \* “: Fundamental frequency.



A D T

EUT TEST CONDITION		MEASUREMENT DETAIL	
CHANNEL	Channel 7	FREQUENCY RANGE	1 ~ 25GHz
INPUT POWER (SYSTEM)	120Vac, 60 Hz	DETECTOR FUNCTION	Peak (PK) Average (AV)
ENVIRONMENTAL CONDITIONS	24deg. C, 65%RH 1020 hPa	TEST MODE	A
TESTED BY	Sun Lin		

ANTENNA POLARITY & TEST DISTANCE: HORIZONTAL AT 3 M								
NO.	FREQ. (MHz)	EMISSION LEVEL (dBuV/m)	LIMIT (dBuV/m)	MARGIN (dB)	ANTENNA HEIGHT (m)	TABLE ANGLE (Degree)	RAW VALUE (dBuV)	CORRECTION FACTOR (dB/m)
1	*2452.00	101.0 PK			1.26 H	108	67.30	33.70
2	*2452.00	90.6 AV			1.26 H	108	56.90	33.70
3	2483.50	69.3 PK	74.0	-4.7	1.26 H	107	35.50	33.80
4	<b>2483.50</b>	<b>53.0 AV</b>	<b>54.0</b>	<b>-1.0</b>	<b>1.26 H</b>	<b>107</b>	<b>19.20</b>	<b>33.80</b>
5	4904.00	49.8 PK	74.0	-24.2	1.12 H	278	9.60	40.20
6	4904.00	37.8 AV	54.0	-16.2	1.12 H	278	-2.40	40.20
ANTENNA POLARITY & TEST DISTANCE: VERTICAL AT 3 M								
NO.	FREQ. (MHz)	EMISSION LEVEL (dBuV/m)	LIMIT (dBuV/m)	MARGIN (dB)	ANTENNA HEIGHT (m)	TABLE ANGLE (Degree)	RAW VALUE (dBuV)	CORRECTION FACTOR (dB/m)
1	*2452.00	96.6 PK			1.00 V	155	62.90	33.70
2	*2452.00	86.7 AV			1.00 V	155	53.00	33.70
3	2483.50	64.1 PK	74.0	-9.9	1.00 V	155	30.30	33.80
4	2483.50	50.0 AV	54.0	-4.0	1.00 V	155	16.20	33.80
5	4904.00	47.6 PK	74.0	-26.4	1.00 V	149	7.40	40.20
6	4904.00	35.7 AV	54.0	-18.3	1.00 V	149	-4.50	40.20

- REMARKS:**
1. Emission level (dBuV/m) = Raw Value (dBuV) + Correction Factor (dB/m).
  2. Correction Factor (dB/m) = Antenna Factor (dB/m) + Cable Factor (dB).
  3. The other emission levels were very low against the limit.
  4. Margin value = Emission level – Limit value.
  5. “ \* “: Fundamental frequency.





A D T

EUT TEST CONDITION		MEASUREMENT DETAIL	
CHANNEL	Channel 1	FREQUENCY RANGE	1 ~ 25GHz
INPUT POWER (SYSTEM)	120Vac, 60 Hz	DETECTOR FUNCTION	Peak (PK) Average (AV)
ENVIRONMENTAL CONDITIONS	24deg. C, 65%RH 1020 hPa	TEST MODE	C
TESTED BY	Sun Lin		

ANTENNA POLARITY & TEST DISTANCE: HORIZONTAL AT 3 M								
NO.	FREQ. (MHz)	EMISSION LEVEL (dBuV/m)	LIMIT (dBuV/m)	MARGIN (dB)	ANTENNA HEIGHT (m)	TABLE ANGLE (Degree)	RAW VALUE (dBuV)	CORRECTION FACTOR (dB/m)
1	2390.00	70.0 PK	74.0	-4.0	1.95 H	269	36.50	33.50
2	2390.00	53.0 AV	54.0	-1.0	1.95 H	269	19.50	33.50
3	*2422.00	104.5 PK			1.97 H	268	70.90	33.60
4	*2422.00	93.3 AV			1.97 H	268	59.70	33.60
5	4844.00	49.0 PK	74.0	-25.0	1.27 H	63	9.00	40.00
6	4844.00	37.2 AV	54.0	-16.8	1.27 H	63	-2.80	40.00
ANTENNA POLARITY & TEST DISTANCE: VERTICAL AT 3 M								
NO.	FREQ. (MHz)	EMISSION LEVEL (dBuV/m)	LIMIT (dBuV/m)	MARGIN (dB)	ANTENNA HEIGHT (m)	TABLE ANGLE (Degree)	RAW VALUE (dBuV)	CORRECTION FACTOR (dB/m)
1	2390.00	65.7 PK	74.0	-8.3	1.68 V	272	32.20	33.50
2	2390.00	52.2 AV	54.0	-1.8	1.68 V	272	18.70	33.50
3	*2422.00	99.6 PK			1.60 V	272	66.00	33.60
4	*2422.00	88.5 AV			1.60 V	272	54.90	33.60
5	4844.00	48.6 PK	74.0	-25.4	1.05 V	163	8.60	40.00
6	4844.00	36.1 AV	54.0	-17.9	1.05 V	163	-3.90	40.00

- REMARKS:**
1. Emission level (dBuV/m) = Raw Value (dBuV) + Correction Factor (dB/m).
  2. Correction Factor (dB/m) = Antenna Factor (dB/m) + Cable Factor (dB).
  3. The other emission levels were very low against the limit.
  4. Margin value = Emission level – Limit value.
  5. “ \* “: Fundamental frequency.



A D T

EUT TEST CONDITION		MEASUREMENT DETAIL	
CHANNEL	Channel 4	FREQUENCY RANGE	1 ~ 25GHz
INPUT POWER (SYSTEM)	120Vac, 60 Hz	DETECTOR FUNCTION	Peak (PK) Average (AV)
ENVIRONMENTAL CONDITIONS	24deg. C, 65%RH 1020 hPa	TEST MODE	C
TESTED BY	Sun Lin		

ANTENNA POLARITY & TEST DISTANCE: HORIZONTAL AT 3 M								
NO.	FREQ. (MHz)	EMISSION LEVEL (dBuV/m)	LIMIT (dBuV/m)	MARGIN (dB)	ANTENNA HEIGHT (m)	TABLE ANGLE (Degree)	RAW VALUE (dBuV)	CORRECTION FACTOR (dB/m)
1	*2437.00	108.9 PK			1.35 H	282	75.20	33.70
2	*2437.00	98.5 AV			1.35 H	282	64.80	33.70
3	2483.50	64.0 PK	74.0	-10.0	1.35 H	282	30.20	33.80
4	<b>2483.50</b>	<b>53.0 AV</b>	<b>54.0</b>	<b>-1.0</b>	<b>1.35 H</b>	<b>282</b>	<b>19.20</b>	<b>33.80</b>
5	4874.00	50.8 PK	74.0	-23.2	1.41 H	263	10.70	40.10
6	4874.00	39.7 AV	54.0	-14.3	1.41 H	263	-0.40	40.10
ANTENNA POLARITY & TEST DISTANCE: VERTICAL AT 3 M								
NO.	FREQ. (MHz)	EMISSION LEVEL (dBuV/m)	LIMIT (dBuV/m)	MARGIN (dB)	ANTENNA HEIGHT (m)	TABLE ANGLE (Degree)	RAW VALUE (dBuV)	CORRECTION FACTOR (dB/m)
1	*2437.00	104.2 PK			1.69 V	267	70.50	33.70
2	*2437.00	93.0 AV			1.69 V	267	59.30	33.70
3	2483.50	65.9 PK	74.0	-8.1	1.68 V	258	32.10	33.80
4	2483.50	52.1 AV	54.0	-1.9	1.68 V	258	18.30	33.80
5	4874.00	48.3 PK	74.0	-25.7	1.07 V	169	8.20	40.10
6	4874.00	36.2 AV	54.0	-17.8	1.07 V	169	-3.90	40.10

- REMARKS:**
1. Emission level (dBuV/m) = Raw Value (dBuV) + Correction Factor (dB/m).
  2. Correction Factor (dB/m) = Antenna Factor (dB/m) + Cable Factor (dB).
  3. The other emission levels were very low against the limit.
  4. Margin value = Emission level – Limit value.
  5. “ \* “: Fundamental frequency.



A D T

EUT TEST CONDITION		MEASUREMENT DETAIL	
CHANNEL	Channel 7	FREQUENCY RANGE	1 ~ 25GHz
INPUT POWER (SYSTEM)	120Vac, 60 Hz	DETECTOR FUNCTION	Peak (PK) Average (AV)
ENVIRONMENTAL CONDITIONS	24deg. C, 65%RH 1020 hPa	TEST MODE	C
TESTED BY	Sun Lin		

ANTENNA POLARITY & TEST DISTANCE: HORIZONTAL AT 3 M								
NO.	FREQ. (MHz)	EMISSION LEVEL (dBuV/m)	LIMIT (dBuV/m)	MARGIN (dB)	ANTENNA HEIGHT (m)	TABLE ANGLE (Degree)	RAW VALUE (dBuV)	CORRECTION FACTOR (dB/m)
1	*2452.00	103.2 PK			1.89 H	267	69.50	33.70
2	*2452.00	92.2 AV			1.89 H	267	58.50	33.70
3	2483.50	68.1 PK	74.0	-5.9	1.88 H	264	34.30	33.80
4	<b>2483.50</b>	<b>53.0 AV</b>	<b>54.0</b>	<b>-1.0</b>	<b>1.88 H</b>	<b>264</b>	<b>19.20</b>	<b>33.80</b>
5	4904.00	49.7 PK	74.0	-24.3	1.36 H	322	9.50	40.20
6	4904.00	37.7 AV	54.0	-16.3	1.36 H	322	-2.50	40.20
ANTENNA POLARITY & TEST DISTANCE: VERTICAL AT 3 M								
NO.	FREQ. (MHz)	EMISSION LEVEL (dBuV/m)	LIMIT (dBuV/m)	MARGIN (dB)	ANTENNA HEIGHT (m)	TABLE ANGLE (Degree)	RAW VALUE (dBuV)	CORRECTION FACTOR (dB/m)
1	*2452.00	98.8 PK			1.58 V	279	65.10	33.70
2	*2452.00	87.3 AV			1.58 V	279	53.60	33.70
3	2483.50	64.5 PK	74.0	-9.5	1.62 V	279	30.70	33.80
4	2483.50	52.0 AV	54.0	-2.0	1.62 V	279	18.20	33.80
5	4904.00	48.3 PK	74.0	-25.7	1.13 V	207	8.10	40.20
6	4904.00	36.0 AV	54.0	-18.0	1.13 V	207	-4.20	40.20

- REMARKS:**
1. Emission level (dBuV/m) = Raw Value (dBuV) + Correction Factor (dB/m).
  2. Correction Factor (dB/m) = Antenna Factor (dB/m) + Cable Factor (dB).
  3. The other emission levels were very low against the limit.
  4. Margin value = Emission level – Limit value.
  5. “ \* “: Fundamental frequency.



A D T

**BELOW 1GHz WORST-CASE DATA : 802.11b**

EUT TEST CONDITION		MEASUREMENT DETAIL	
CHANNEL	Channel 6	FREQUENCY RANGE	Below 1000MHz
INPUT POWER (SYSTEM)	120Vac, 60 Hz	DETECTOR FUNCTION	Quasi-Peak
ENVIRONMENTAL CONDITIONS	25deg. C, 65%RH 1008 hPa	TEST MODE	A
TESTED BY	Brad Wu		

ANTENNA POLARITY & TEST DISTANCE: HORIZONTAL AT 3 M								
NO.	FREQ. (MHz)	EMISSION LEVEL (dBuV/m)	LIMIT (dBuV/m)	MARGIN (dB)	ANTENNA HEIGHT (m)	TABLE ANGLE (Degree)	RAW VALUE (dBuV)	CORRECTION FACTOR (dB/m)
1	64.90	35.8 QP	40.0	-4.2	2.50 H	13	23.20	12.60
2	199.05	37.9 QP	43.5	-5.6	1.75 H	256	27.60	10.30
3	374.04	42.7 QP	46.0	-3.3	1.00 H	286	26.20	16.50
4	500.42	41.0 QP	46.0	-5.0	1.75 H	190	21.20	19.80
5	624.85	43.6 QP	46.0	-2.4	1.25 H	43	21.20	22.40
6	720.12	44.7 QP	46.0	-1.3	1.00 H	7	20.90	23.80
ANTENNA POLARITY & TEST DISTANCE: VERTICAL AT 3 M								
NO.	FREQ. (MHz)	EMISSION LEVEL (dBuV/m)	LIMIT (dBuV/m)	MARGIN (dB)	ANTENNA HEIGHT (m)	TABLE ANGLE (Degree)	RAW VALUE (dBuV)	CORRECTION FACTOR (dB/m)
1	43.51	37.9 QP	40.0	-2.1	1.00 V	10	23.50	14.40
2	156.28	38.4 QP	43.5	-5.1	1.50 V	322	23.90	14.50
3	399.31	41.1 QP	46.0	-4.9	1.00 V	166	24.00	17.10
4	500.42	39.6 QP	46.0	-6.4	1.75 V	172	19.80	19.80
5	751.23	39.8 QP	46.0	-6.2	1.50 V	28	15.70	24.10
6	955.38	44.8 QP	46.0	-1.2	1.75 V	232	18.10	26.70

- REMARKS:**
1. Emission level (dBuV/m) = Raw Value (dBuV) + Correction Factor (dB/m).
  2. Correction Factor (dB/m) = Antenna Factor (dB/m) + Cable Factor (dB).
  3. The other emission levels were very low against the limit.
  4. Margin value = Emission level – Limit value.



A D T

EUT TEST CONDITION		MEASUREMENT DETAIL	
CHANNEL	Channel 6	FREQUENCY RANGE	Below 1000MHz
INPUT POWER (SYSTEM)	120Vac, 60 Hz	DETECTOR FUNCTION	Quasi-Peak
ENVIRONMENTAL CONDITIONS	25deg. C, 65%RH 1008 hPa	TEST MODE	B
TESTED BY	Brad Wu		

ANTENNA POLARITY & TEST DISTANCE: HORIZONTAL AT 3 M								
NO.	FREQ. (MHz)	EMISSION LEVEL (dBuV/m)	LIMIT (dBuV/m)	MARGIN (dB)	ANTENNA HEIGHT (m)	TABLE ANGLE (Degree)	RAW VALUE (dBuV)	CORRECTION FACTOR (dB/m)
1	35.98	37.9 QP	40.0	-2.1	2.93 H	19	25.10	12.80
2	200.00	42.0 QP	43.5	-1.5	1.33 H	244	31.80	10.20
3	399.31	41.7 QP	46.0	-4.3	1.00 H	112	24.60	17.10
4	599.58	41.6 QP	46.0	-4.4	1.25 H	343	19.60	22.00
5	720.04	44.8 QP	46.0	-1.2	1.08 H	9	21.00	23.80
6	799.84	43.4 QP	46.0	-2.6	1.00 H	55	18.80	24.60
ANTENNA POLARITY & TEST DISTANCE: VERTICAL AT 3 M								
NO.	FREQ. (MHz)	EMISSION LEVEL (dBuV/m)	LIMIT (dBuV/m)	MARGIN (dB)	ANTENNA HEIGHT (m)	TABLE ANGLE (Degree)	RAW VALUE (dBuV)	CORRECTION FACTOR (dB/m)
1	47.41	39.0 QP	40.0	-1.0	1.00 V	340	24.60	14.40
2	199.05	36.7 QP	43.5	-6.8	1.75 V	178	26.40	10.30
3	399.31	42.9 QP	46.0	-3.1	1.00 V	175	25.80	17.10
4	599.58	33.0 QP	46.0	-13.0	2.00 V	115	11.00	22.00
5	720.12	36.2 QP	46.0	-9.8	1.00 V	280	12.40	23.80
6	960.00	30.3 QP	46.0	-15.7	1.00 V	55	3.50	26.80

- REMARKS:**
1. Emission level (dBuV/m) = Raw Value (dBuV) + Correction Factor (dB/m).
  2. Correction Factor (dB/m) = Antenna Factor (dB/m) + Cable Factor (dB).
  3. The other emission levels were very low against the limit.
  4. Margin value = Emission level – Limit value.



A D T

802.11g

EUT TEST CONDITION		MEASUREMENT DETAIL	
CHANNEL	Channel 6	FREQUENCY RANGE	Below 1000MHz
INPUT POWER (SYSTEM)	120Vac, 60 Hz	DETECTOR FUNCTION	Quasi-Peak
ENVIRONMENTAL CONDITIONS	25deg. C, 65%RH 1008 hPa	TEST MODE	C
TESTED BY	Brad Wu		

ANTENNA POLARITY & TEST DISTANCE: HORIZONTAL AT 3 M								
NO.	FREQ. (MHz)	EMISSION LEVEL (dBuV/m)	LIMIT (dBuV/m)	MARGIN (dB)	ANTENNA HEIGHT (m)	TABLE ANGLE (Degree)	RAW VALUE (dBuV)	CORRECTION FACTOR (dB/m)
1	374.04	43.2 QP	46.0	-2.8	1.00 H	133	26.70	16.50
2	399.31	44.9 QP	46.0	-1.1	2.50 H	220	27.80	17.10
3	624.85	43.7 QP	46.0	-2.3	1.25 H	34	21.30	22.40
4	720.23	44.8 QP	46.0	-1.2	1.02 H	35	21.00	23.80
5	751.23	43.9 QP	46.0	-2.1	1.00 H	355	19.80	24.10
6	797.89	43.3 QP	46.0	-2.7	1.00 H	139	18.70	24.60

ANTENNA POLARITY & TEST DISTANCE: VERTICAL AT 3 M								
NO.	FREQ. (MHz)	EMISSION LEVEL (dBuV/m)	LIMIT (dBuV/m)	MARGIN (dB)	ANTENNA HEIGHT (m)	TABLE ANGLE (Degree)	RAW VALUE (dBuV)	CORRECTION FACTOR (dB/m)
1	41.57	36.9 QP	40.0	-3.1	1.00 V	295	22.50	14.40
2	156.28	36.2 QP	43.5	-7.3	1.25 V	352	21.70	14.50
3	374.04	38.5 QP	46.0	-7.5	1.00 V	169	22.00	16.50
4	500.42	39.6 QP	46.0	-6.4	1.75 V	172	19.80	19.80
5	751.23	39.4 QP	46.0	-6.6	1.25 V	10	15.30	24.10
6	957.33	44.1 QP	46.0	-1.9	1.00 V	241	17.30	26.80

- REMARKS:**
1. Emission level (dBuV/m) = Raw Value (dBuV) + Correction Factor (dB/m).
  2. Correction Factor (dB/m) = Antenna Factor (dB/m) + Cable Factor (dB).
  3. The other emission levels were very low against the limit.
  4. Margin value = Emission level – Limit value.



A D T

EUT TEST CONDITION		MEASUREMENT DETAIL	
CHANNEL	Channel 6	FREQUENCY RANGE	Below 1000MHz
INPUT POWER (SYSTEM)	120Vac, 60 Hz	DETECTOR FUNCTION	Quasi-Peak
ENVIRONMENTAL CONDITIONS	25deg. C, 65%RH 1008 hPa	TEST MODE	D
TESTED BY	Brad Wu		

ANTENNA POLARITY & TEST DISTANCE: HORIZONTAL AT 3 M								
NO.	FREQ. (MHz)	EMISSION LEVEL (dBuV/m)	LIMIT (dBuV/m)	MARGIN (dB)	ANTENNA HEIGHT (m)	TABLE ANGLE (Degree)	RAW VALUE (dBuV)	CORRECTION FACTOR (dB/m)
1	45.45	38.6 QP	40.0	-1.4	3.00 H	40	24.20	14.40
2	200.00	40.6 QP	43.5	-2.9	1.33 H	245	30.40	10.20
3	399.31	43.9 QP	46.0	-2.1	2.50 H	157	26.80	17.10
4	599.58	40.0 QP	46.0	-6.0	1.50 H	343	18.00	22.00
5	720.03	44.9 QP	46.0	-1.1	1.06 H	6	21.10	23.80
6	960.00	33.8 QP	46.0	-12.2	1.50 H	226	7.00	26.80
ANTENNA POLARITY & TEST DISTANCE: VERTICAL AT 3 M								
NO.	FREQ. (MHz)	EMISSION LEVEL (dBuV/m)	LIMIT (dBuV/m)	MARGIN (dB)	ANTENNA HEIGHT (m)	TABLE ANGLE (Degree)	RAW VALUE (dBuV)	CORRECTION FACTOR (dB/m)
1	45.45	39.0 QP	40.0	-1.0	1.50 V	322	24.60	14.40
2	199.05	34.9 QP	43.5	-8.6	1.75 V	169	24.60	10.30
3	333.21	36.1 QP	46.0	-9.9	1.50 V	232	20.60	15.50
4	399.31	38.3 QP	46.0	-7.7	3.00 V	178	21.20	17.10
5	667.63	35.4 QP	46.0	-10.6	1.75 V	280	12.30	23.10
6	834.84	41.0 QP	46.0	-5.0	4.00 V	37	15.90	25.10

- REMARKS:**
1. Emission level (dBuV/m) = Raw Value (dBuV) + Correction Factor (dB/m).
  2. Correction Factor (dB/m) = Antenna Factor (dB/m) + Cable Factor (dB).
  3. The other emission levels were very low against the limit.
  4. Margin value = Emission level – Limit value.



## 4.2 CONDUCTED EMISSION MEASUREMENT

### 4.2.1 LIMITS OF CONDUCTED EMISSION MEASUREMENT

FREQUENCY OF EMISSION (MHz)	CONDUCTED LIMIT (dBµV)	
	Quasi-peak	Average
0.15 ~ 0.5	66 to 56	56 to 46
0.5 ~ 5	56	46
5 ~ 30	60	50

- NOTE:** 1. The lower limit shall apply at the transition frequencies.  
 2. The limit decreases in line with the logarithm of the frequency in the range of 0.15 to 0.50MHz.  
 3. All emanations from a class A/B digital device or system, including any network of conductors and apparatus connected thereto, shall not exceed the level of field strengths specified above.

### 4.2.2 TEST INSTRUMENTS

DESCRIPTION & MANUFACTURER	MODEL NO.	SERIAL NO.	DATE OF CALIBRATION	DUE DATE OF CALIBRATION
Test Receiver ROHDE & SCHWARZ	ESCS30	100291	Dec. 16, 2009	Dec. 15, 2010
RF signal cable Woken	5D-FB	Cable-HYC01-01	Nov. 12, 2009	Nov. 11, 2010
LISN ROHDE & SCHWARZ	ESH3-Z5	100312	Jun. 28, 2010	Jun. 27, 2011
LISN ROHDE & SCHWARZ	ESH3-Z5	835239/001	Feb. 10, 2010	Feb. 09, 2011
Software ADT	ADT_Cond_ V7.3.7	NA	NA	NA

- NOTE:** 1. The calibration interval of the above test instruments is 12 months and the calibrations are traceable to NML/ROC and NIST/USA.  
 2. The test was performed in HwaYa Shielded Room 1.  
 3. The VCCI Site Registration No. is C-2040.





A D T

#### 4.2.3 TEST PROCEDURES

- a. The EUT was placed 0.4 meters from the conducting wall of the shielded room with EUT being connected to the power mains through a line impedance stabilization network (LISN). Other support units were connected to the power mains through another LISN. The two LISNs provide 50 ohm/ 50uH of coupling impedance for the measuring instrument.
- b. Both lines of the power mains connected to the EUT were checked for maximum conducted interference.
- c. The frequency range from 150kHz to 30MHz was searched. Emission levels under (Limit - 20dB) was not recorded.

**NOTE:** All modes of operation were investigated and the worst-case emissions are reported.

#### 4.2.4 DEVIATION FROM TEST STANDARD

No deviation

#### 4.2.5 TEST SETUP

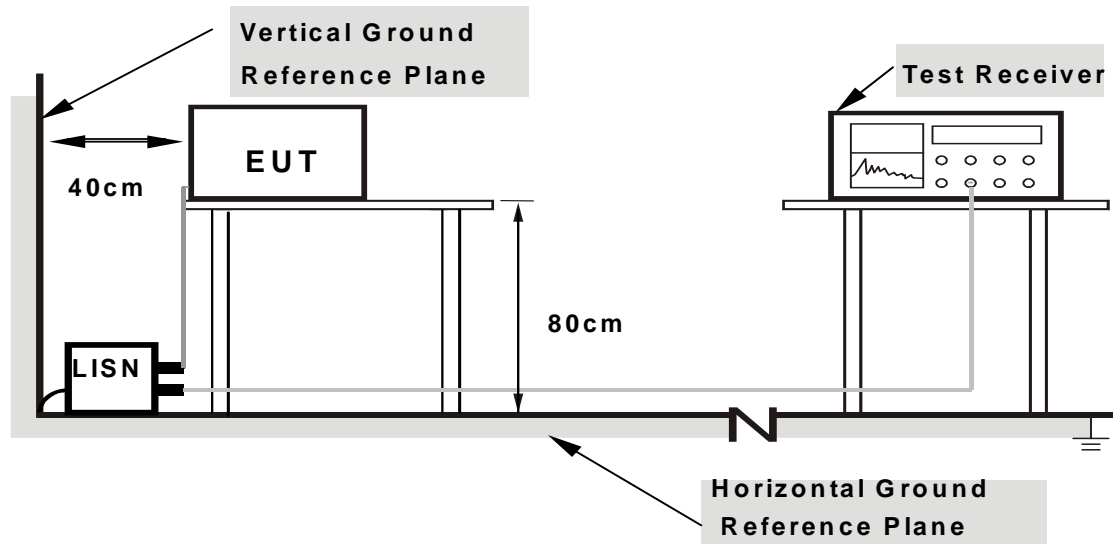

- Note:**
1. Support units were connected to second LISN.
  2. Both of LISNs (AMN) are 80 cm from EUT and at least 80 cm from other units and other metal planes

For the actual test configuration, please refer to the attached file (Test Setup Photo).

#### 4.2.6 EUT OPERATING CONDITIONS

Same as 4.1.6.

### 4.2.7 TEST RESULTS

#### CONDUCTED WORST-CASE DATA : 802.11b

PHASE	Line 1	6dB BANDWIDTH	9kHz
TEST MODE	A		

No	Freq. [MHz]	Corr. Factor (dB)	Reading Value		Emission Level		Limit		Margin	
			[dB (uV)]		[dB (uV)]		[dB (uV)]		(dB)	
			Q.P.	AV.	Q.P.	AV.	Q.P.	AV.	Q.P.	AV.
1	0.181	0.11	56.88	45.81	56.99	45.92	64.43	54.43	-7.43	-8.50
2	0.238	0.11	49.52	-	49.63	-	62.15	52.15	-12.52	-
3	0.298	0.12	43.43	-	43.55	-	60.29	50.29	-16.74	-
4	0.541	0.14	38.67	-	38.81	-	56.00	46.00	-17.19	-
5	2.066	0.25	25.42	-	25.67	-	56.00	46.00	-30.33	-
6	13.527	0.93	28.07	-	29.00	-	60.00	50.00	-31.00	-

- REMARKS:**
1. Q.P. and AV. are abbreviations of quasi-peak and average individually.
  2. "-": The Quasi-peak reading value also meets average limit and measurement with the average detector is unnecessary.
  3. The emission levels of other frequencies were very low against the limit.
  4. Margin value = Emission level - Limit value
  5. Correction factor = Insertion loss + Cable loss
  6. Emission Level = Correction Factor + Reading Value.

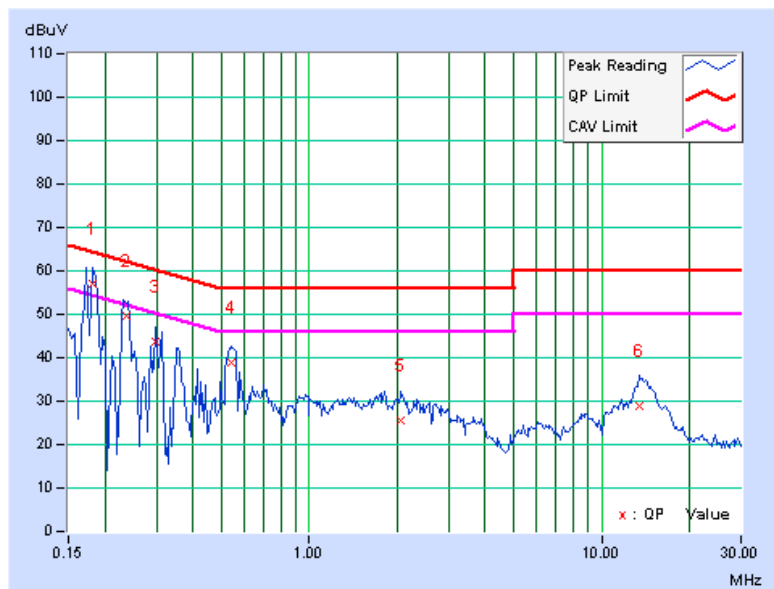



A D T

PHASE	Line 2	6dB BANDWIDTH	9kHz
TEST MODE	A		

No	Freq. [MHz]	Corr. Factor (dB)	Reading Value [dB (uV)]		Emission Level [dB (uV)]		Limit [dB (uV)]		Margin (dB)	
			Q.P.	AV.	Q.P.	AV.	Q.P.	AV.	Q.P.	AV.
1	0.185	0.10	54.96	41.26	55.06	41.36	64.25	54.25	-9.19	-12.89
2	0.244	0.10	47.75	-	47.85	-	61.97	51.97	-14.11	-
3	0.302	0.11	41.56	-	41.67	-	60.18	50.18	-18.51	-
4	0.560	0.13	33.24	-	33.37	-	56.00	46.00	-22.63	-
5	2.938	0.28	24.25	-	24.53	-	56.00	46.00	-31.47	-
6	13.500	0.81	28.46	-	29.27	-	60.00	50.00	-30.73	-

- REMARKS:**
1. Q.P. and AV. are abbreviations of quasi-peak and average individually.
  2. "-": The Quasi-peak reading value also meets average limit and measurement with the average detector is unnecessary.
  3. The emission levels of other frequencies were very low against the limit.
  4. Margin value = Emission level - Limit value
  5. Correction factor = Insertion loss + Cable loss
  6. Emission Level = Correction Factor + Reading Value.

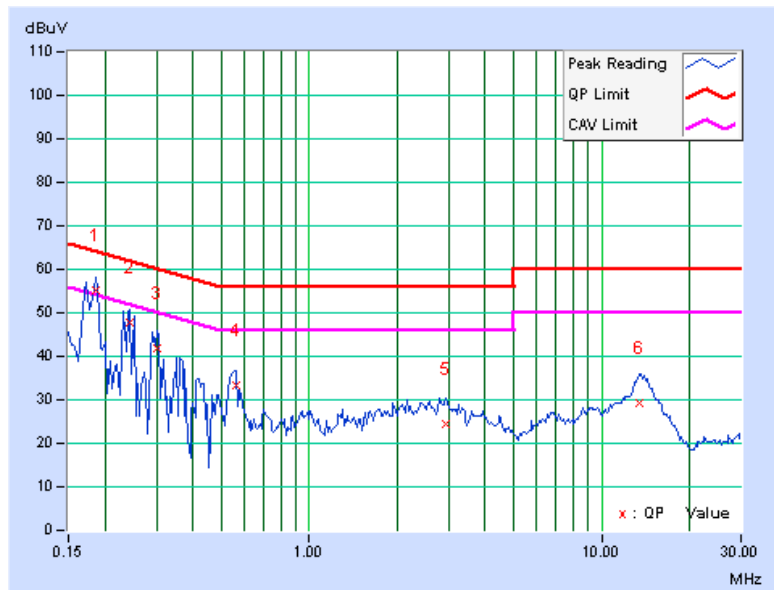



A D T

PHASE	Line 1	6dB BANDWIDTH	9kHz
TEST MODE	B		

No	Freq. [MHz]	Corr. Factor (dB)	Reading Value [dB (uV)]		Emission Level [dB (uV)]		Limit [dB (uV)]		Margin (dB)	
			Q.P.	AV.	Q.P.	AV.	Q.P.	AV.	Q.P.	AV.
1	0.177	0.11	47.09	-	47.20	-	64.61	54.61	-17.40	-
2	0.267	0.12	38.33	-	38.45	-	61.20	51.20	-22.76	-
3	0.357	0.13	40.38	-	40.51	-	58.80	48.80	-18.29	-
4	0.624	0.15	33.32	-	33.47	-	56.00	46.00	-22.53	-
5	23.129	1.68	46.89	-	48.57	-	60.00	50.00	-11.43	-
6	27.342	1.92	37.73	-	39.65	-	60.00	50.00	-20.35	-

- REMARKS:**
1. Q.P. and AV. are abbreviations of quasi-peak and average individually.
  2. "-": The Quasi-peak reading value also meets average limit and measurement with the average detector is unnecessary.
  3. The emission levels of other frequencies were very low against the limit.
  4. Margin value = Emission level - Limit value
  5. Correction factor = Insertion loss + Cable loss
  6. Emission Level = Correction Factor + Reading Value.

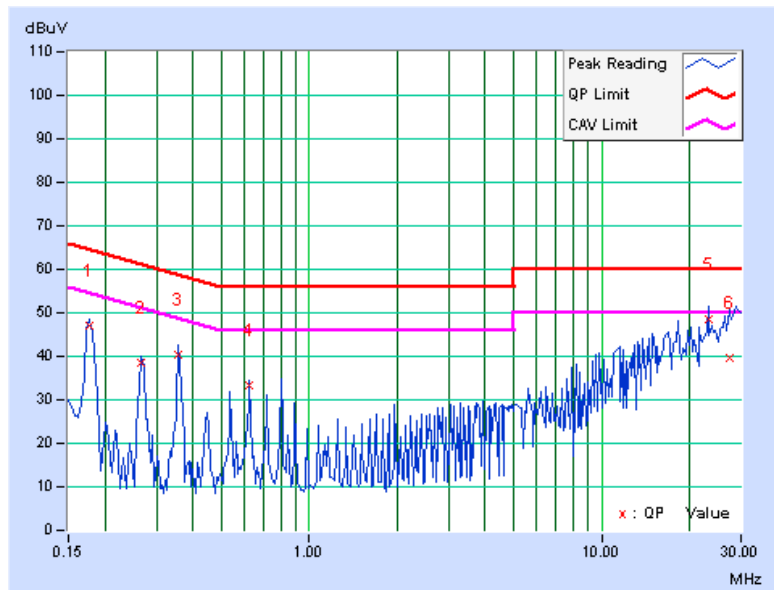

PHASE	Line 2	6dB BANDWIDTH	9kHz
TEST MODE	B		

No	Freq. [MHz]	Corr. Factor (dB)	Reading Value [dB (uV)]		Emission Level [dB (uV)]		Limit [dB (uV)]		Margin (dB)	
			Q.P.	AV.	Q.P.	AV.	Q.P.	AV.	Q.P.	AV.
1	0.177	0.10	50.64	-	50.74	-	64.61	54.61	-13.87	-
2	0.267	0.11	37.51	-	37.62	-	61.20	51.20	-23.59	-
3	0.357	0.12	36.84	-	36.96	-	58.80	48.80	-21.84	-
4	0.627	0.14	30.29	-	30.43	-	56.00	46.00	-25.57	-
5	23.129	1.47	47.70	-	49.17	-	60.00	50.00	-10.83	-
6	29.107	1.76	48.84	46.82	50.60	48.58	60.00	50.00	-9.40	-1.42

- REMARKS:**
1. Q.P. and AV. are abbreviations of quasi-peak and average individually.
  2. "-": The Quasi-peak reading value also meets average limit and measurement with the average detector is unnecessary.
  3. The emission levels of other frequencies were very low against the limit.
  4. Margin value = Emission level - Limit value
  5. Correction factor = Insertion loss + Cable loss
  6. Emission Level = Correction Factor + Reading Value.

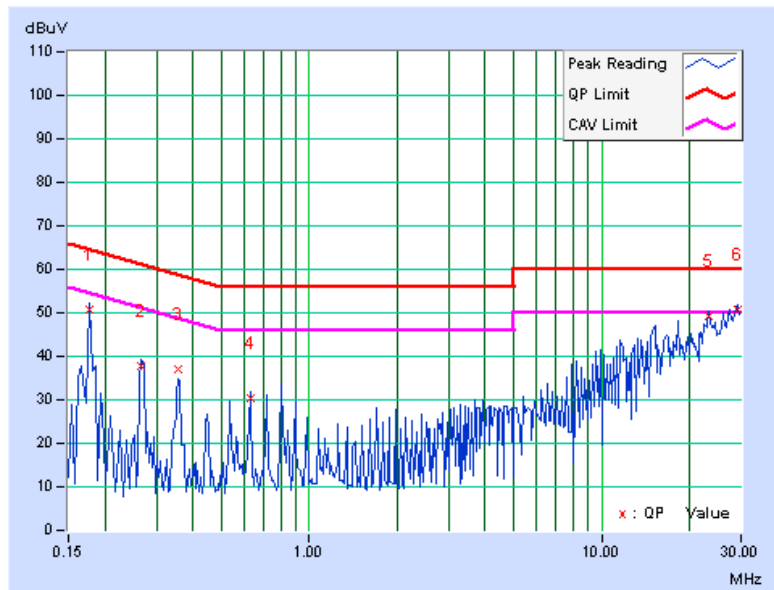

**CONDUCTED WORST-CASE DATA : 802.11g**

<b>PHASE</b>	Line 1	<b>6dB BANDWIDTH</b>	9kHz
<b>TEST MODE</b>	C		

No	Freq. [MHz]	Corr. Factor (dB)	Reading Value		Emission Level		Limit		Margin	
			[dB (uV)]		[dB (uV)]		[dB (uV)]		(dB)	
			Q.P.	AV.	Q.P.	AV.	Q.P.	AV.	Q.P.	AV.
1	0.185	0.11	55.18	44.21	55.29	44.32	64.25	54.25	-8.96	-9.93
2	0.244	0.11	47.35	-	47.46	-	61.97	51.97	-14.50	-
3	0.302	0.12	41.84	-	41.96	-	60.18	50.18	-18.22	-
4	0.560	0.14	39.26	-	39.40	-	56.00	46.00	-16.60	-
5	1.754	0.23	26.72	-	26.95	-	56.00	46.00	-29.05	-
6	13.613	0.94	29.14	-	30.08	-	60.00	50.00	-29.92	-

- REMARKS:**
1. Q.P. and AV. are abbreviations of quasi-peak and average individually.
  2. "-": The Quasi-peak reading value also meets average limit and measurement with the average detector is unnecessary.
  3. The emission levels of other frequencies were very low against the limit.
  4. Margin value = Emission level - Limit value
  5. Correction factor = Insertion loss + Cable loss
  6. Emission Level = Correction Factor + Reading Value.

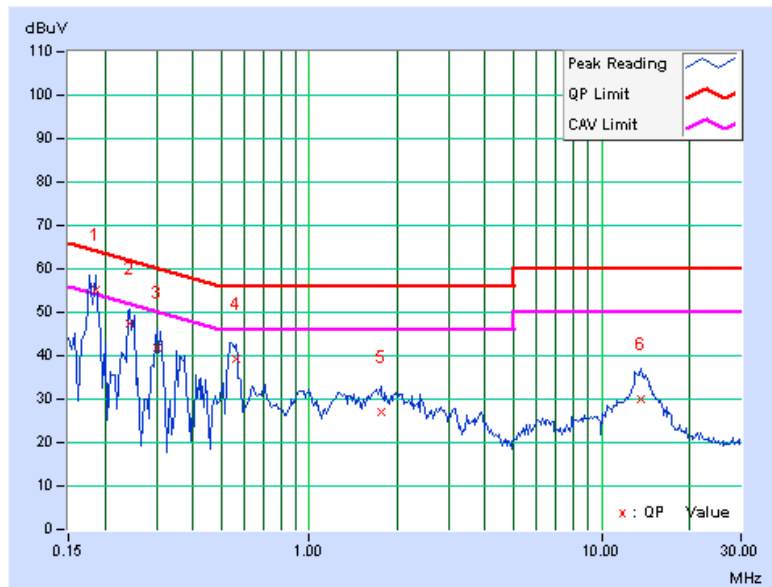

PHASE	Line 2	6dB BANDWIDTH	9kHz
TEST MODE	C		

No	Freq. [MHz]	Corr. Factor (dB)	Reading Value [dB (uV)]		Emission Level [dB (uV)]		Limit [dB (uV)]		Margin (dB)	
			Q.P.	AV.	Q.P.	AV.	Q.P.	AV.	Q.P.	AV.
1	0.181	0.10	53.93	-	54.03	-	64.43	54.43	-10.40	-
2	0.236	0.10	46.84	-	46.94	-	62.24	52.24	-15.29	-
3	0.310	0.11	39.97	-	40.08	-	59.97	49.97	-19.89	-
4	0.548	0.13	32.13	-	32.26	-	56.00	46.00	-23.74	-
5	2.172	0.25	23.73	-	23.98	-	56.00	46.00	-32.02	-
6	13.840	0.84	29.16	-	30.00	-	60.00	50.00	-30.00	-

- REMARKS:**
1. Q.P. and AV. are abbreviations of quasi-peak and average individually.
  2. "-": The Quasi-peak reading value also meets average limit and measurement with the average detector is unnecessary.
  3. The emission levels of other frequencies were very low against the limit.
  4. Margin value = Emission level - Limit value
  5. Correction factor = Insertion loss + Cable loss
  6. Emission Level = Correction Factor + Reading Value.

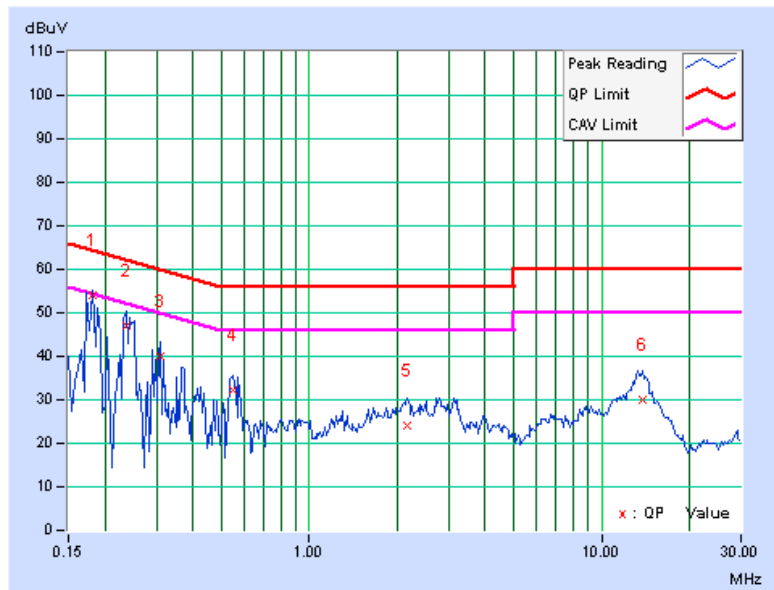





A D T

PHASE	Line 1	6dB BANDWIDTH	9kHz
TEST MODE	D		

No	Freq. [MHz]	Corr. Factor (dB)	Reading Value [dB (uV)]		Emission Level [dB (uV)]		Limit [dB (uV)]		Margin (dB)	
			Q.P.	AV.	Q.P.	AV.	Q.P.	AV.	Q.P.	AV.
1	0.181	0.11	46.26	-	46.37	-	64.43	54.43	-18.05	-
2	0.272	0.12	39.95	-	40.07	-	61.04	51.04	-20.98	-
3	0.364	0.13	40.79	-	40.92	-	58.65	48.65	-17.73	-
4	0.814	0.16	34.85	-	35.01	-	56.00	46.00	-20.99	-
5	23.129	1.68	46.73	-	48.41	-	60.00	50.00	-11.59	-
6	29.128	2.02	48.41	46.98	50.43	49.00	60.00	50.00	-9.57	-1.00

- REMARKS:**
1. Q.P. and AV. are abbreviations of quasi-peak and average individually.
  2. "-": The Quasi-peak reading value also meets average limit and measurement with the average detector is unnecessary.
  3. The emission levels of other frequencies were very low against the limit.
  4. Margin value = Emission level - Limit value
  5. Correction factor = Insertion loss + Cable loss
  6. Emission Level = Correction Factor + Reading Value.

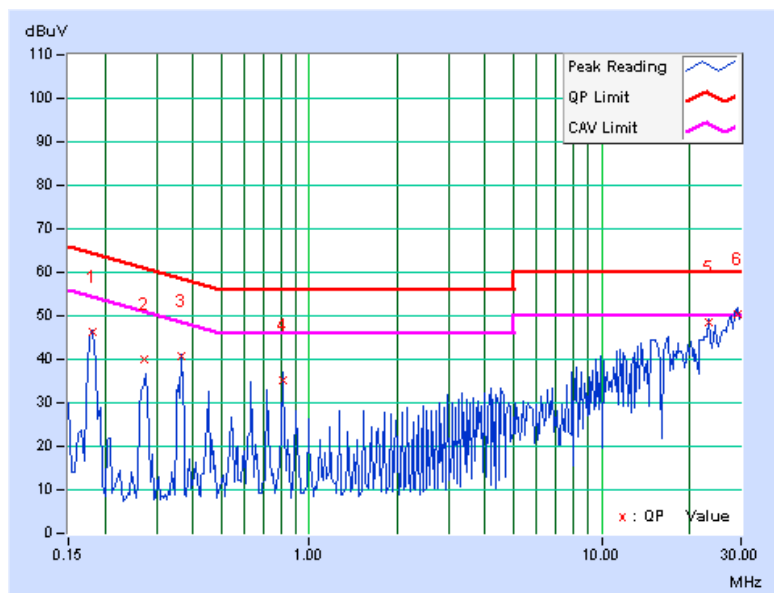

PHASE	Line 2	6dB BANDWIDTH	9kHz
TEST MODE	D		

No	Freq. [MHz]	Corr. Factor (dB)	Reading Value [dB (uV)]		Emission Level [dB (uV)]		Limit [dB (uV)]		Margin (dB)	
			Q.P.	AV.	Q.P.	AV.	Q.P.	AV.	Q.P.	AV.
1	0.181	0.10	49.27	-	49.37	-	64.43	54.43	-15.06	-
2	0.271	0.11	35.71	-	35.82	-	61.08	51.08	-25.27	-
3	0.361	0.12	36.88	-	37.00	-	58.71	48.71	-21.71	-
4	0.633	0.14	30.43	-	30.57	-	56.00	46.00	-25.43	-
5	23.129	1.47	47.60	-	49.07	-	60.00	50.00	-10.93	-
6	29.124	1.76	48.78	47.14	50.54	48.90	60.00	50.00	-9.46	-1.10

- REMARKS:**
1. Q.P. and AV. are abbreviations of quasi-peak and average individually.
  2. "-": The Quasi-peak reading value also meets average limit and measurement with the average detector is unnecessary.
  3. The emission levels of other frequencies were very low against the limit.
  4. Margin value = Emission level - Limit value
  5. Correction factor = Insertion loss + Cable loss
  6. Emission Level = Correction Factor + Reading Value.

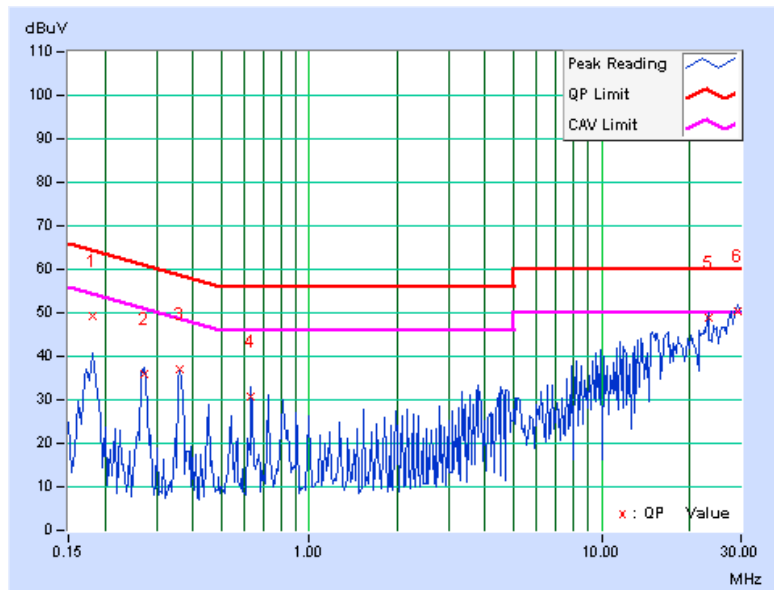



A D T

### 4.3 6dB BANDWIDTH MEASUREMENT

#### 4.3.1 LIMITS OF 6dB BANDWIDTH MEASUREMENT

The minimum of 6dB Bandwidth Measurement is 0.5 MHz.

#### 4.3.2 TEST INSTRUMENTS

DESCRIPTION & MANUFACTURER	MODEL NO.	SERIAL NO.	DATE OF CALIBRATION	DUE DATE OF CALIBRATION
SPECTRUM ANALYZER R&S	FSP40	100039	Jan. 11, 2010	Jan. 10, 2011

**NOTE:** The calibration interval of the above test instruments is 12 months and the calibrations are traceable to NML/ROC and NIST/USA.

#### 4.3.3 TEST PROCEDURE

The transmitter output was connected to the spectrum analyzer through an attenuator. The bandwidth of the fundamental frequency was measured by spectrum analyzer with 100kHz RBW and 300kHz VBW. The 6dB bandwidth is defined as the total spectrum the power of which is higher than peak power minus 6dB.

#### 4.3.4 DEVIATION FROM TEST STANDARD

No deviation

#### 4.3.5 TEST SETUP

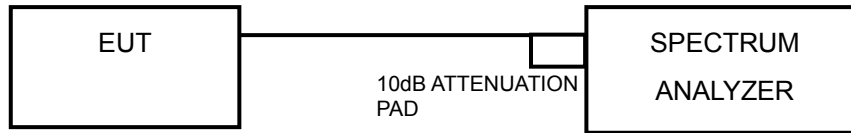

#### 4.3.6 EUT OPERATING CONDITIONS

The software provided by client to enable the EUT under transmission condition continuously at lowest, middle and highest channel frequencies individually.



A D T

### 4.3.7 TEST RESULTS

#### 802.11b

#### TEST MODE A

CHANNEL	CHANNEL FREQUENCY (MHz)	6dB BANDWIDTH (MHz)		MINIMUM LIMIT (MHz)	PASS / FAIL
		CHAIN 0	CHAIN 1		
1	2412	12.05	12.06	0.5	PASS
6	2437	11.18	12.08	0.5	PASS
11	2462	12.61	12.61	0.5	PASS

#### CHAIN 0: CH 11

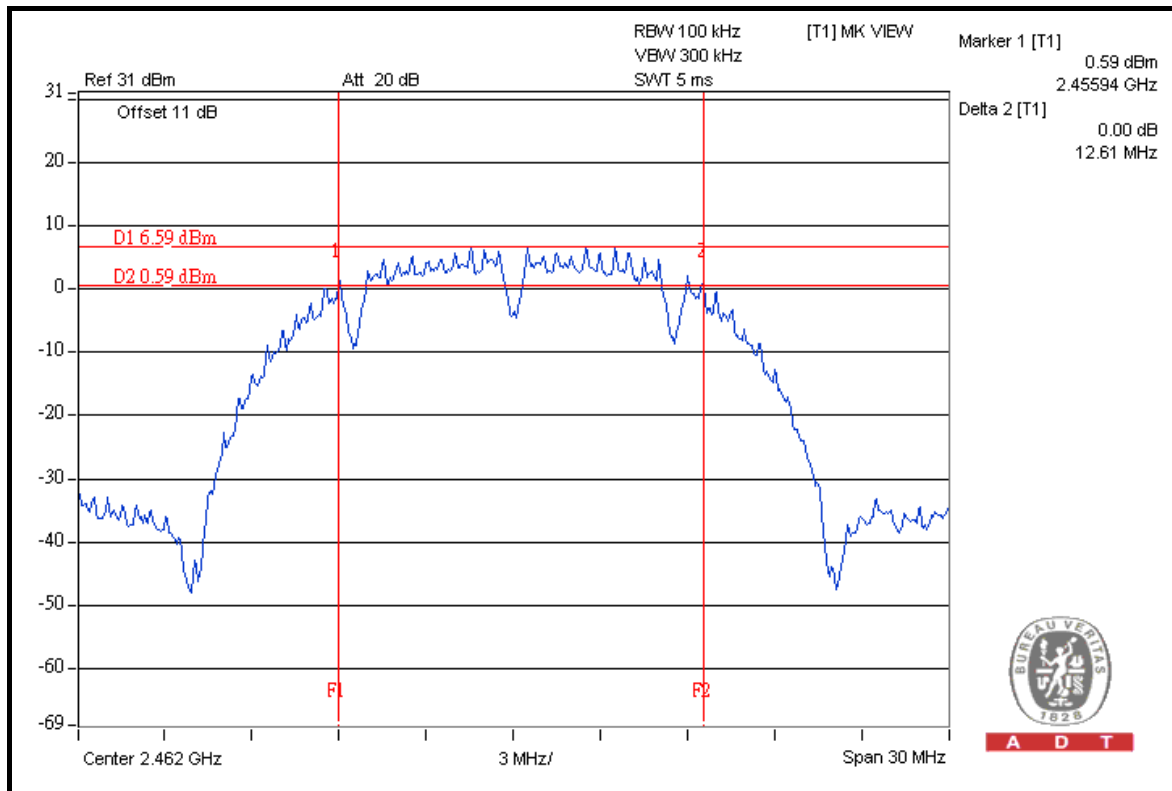



A D T

### TEST MODE C

CHANNEL	CHANNEL FREQUENCY (MHz)	6dB BANDWIDTH (MHz)		MINIMUM LIMIT (MHz)	PASS / FAIL
		CHAIN 0	CHAIN 1		
1	2412	12.15	11.61	0.5	PASS
6	2437	11.15	12.14	0.5	PASS
11	2462	12.09	12.13	0.5	PASS

### CHAIN 0: CH 1

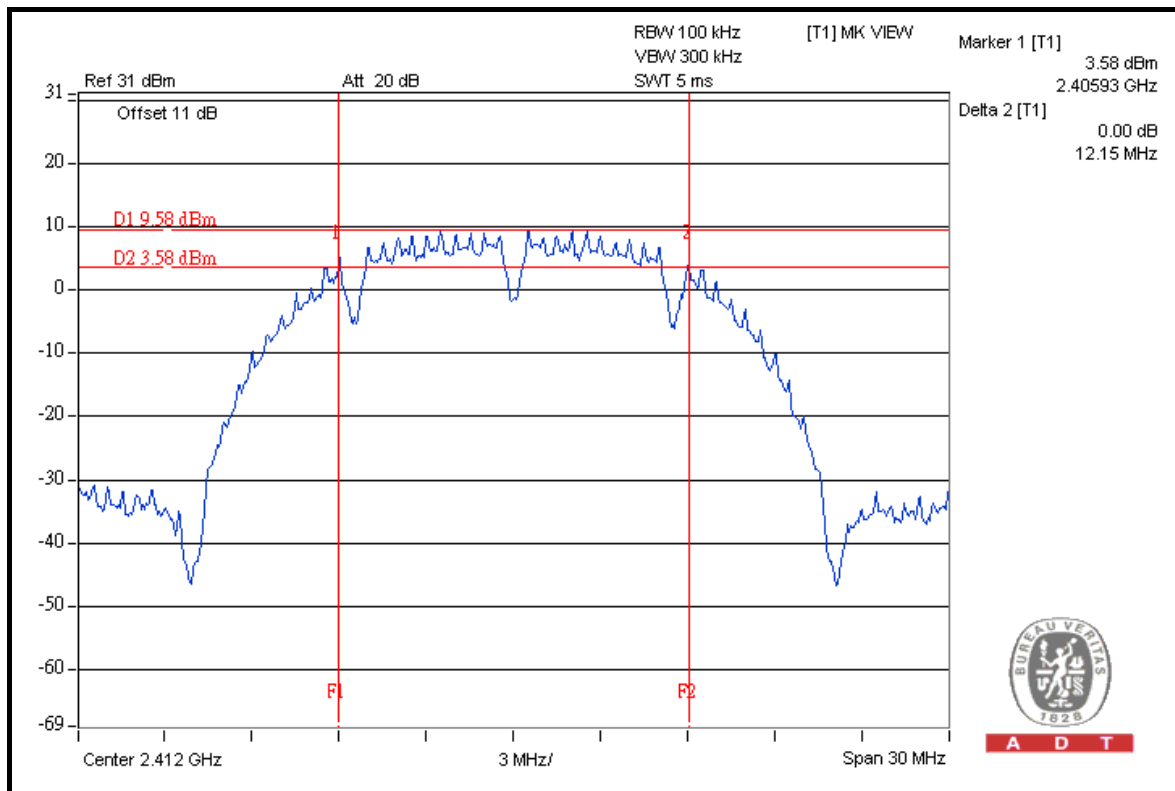



A D T

### 802.11g

### TEST MODE A

CHANNEL	CHANNEL FREQUENCY (MHz)	6dB BANDWIDTH (MHz)		MINIMUM LIMIT (MHz)	PASS / FAIL
		CHAIN 0	CHAIN 1		
1	2412	16.46	16.11	0.5	PASS
6	2437	16.44	16.45	0.5	PASS
11	2462	16.45	16.38	0.5	PASS

### CHAIN 0: CH 1

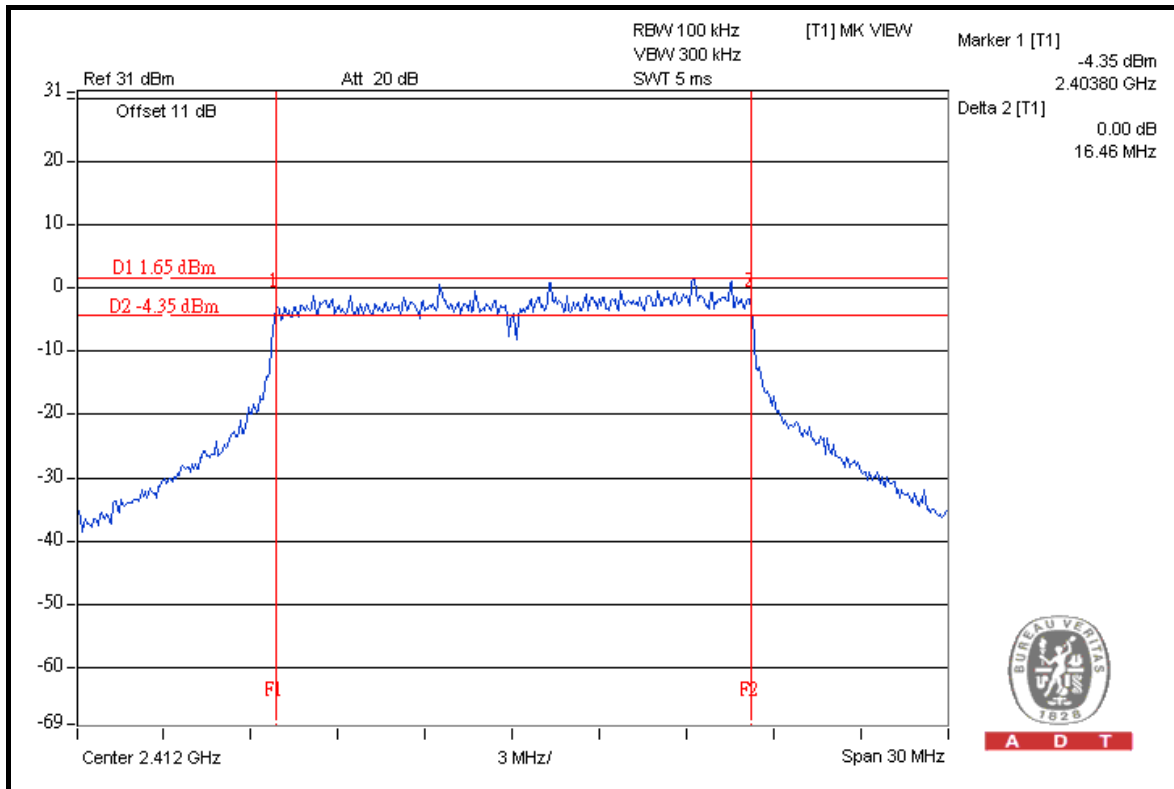



A D T

### TEST MODE C

CHANNEL	CHANNEL FREQUENCY (MHz)	6dB BANDWIDTH (MHz)		MINIMUM LIMIT (MHz)	PASS / FAIL
		CHAIN 0	CHAIN 1		
1	2412	16.46	16.45	0.5	PASS
6	2437	16.44	16.46	0.5	PASS
11	2462	16.44	16.42	0.5	PASS

### CHAIN 0: CH 1

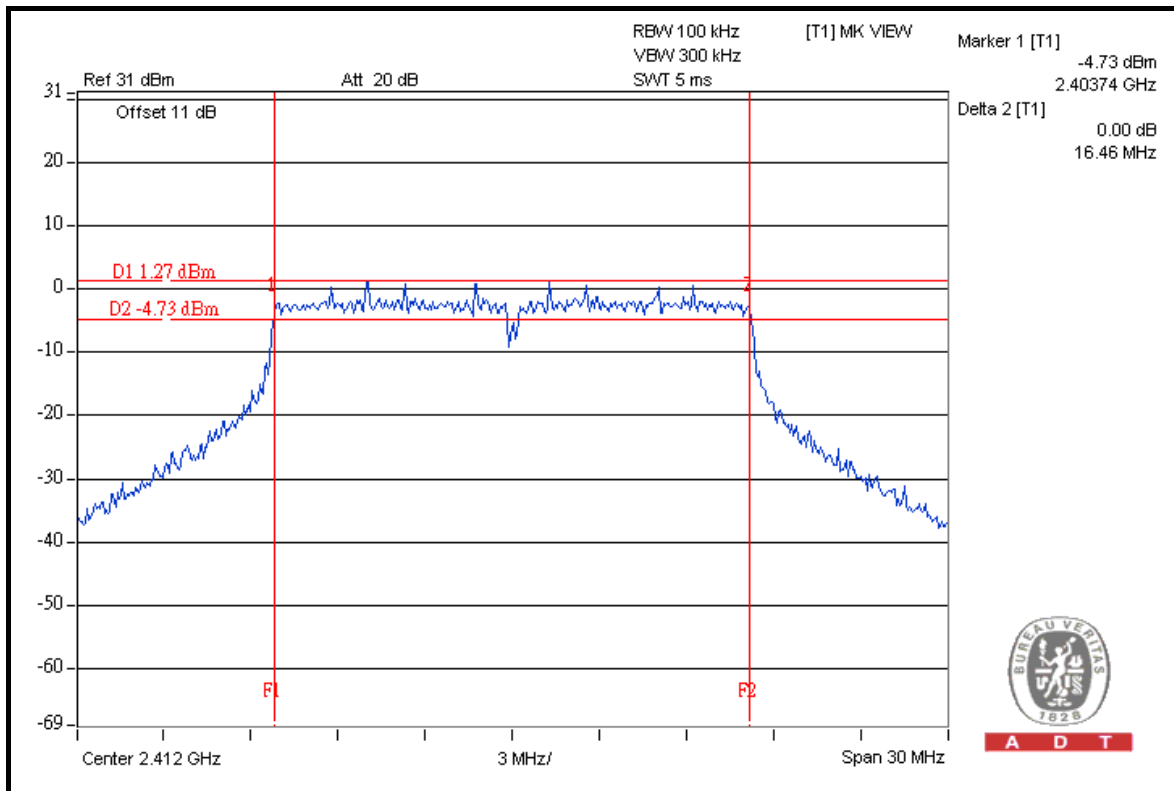

A D T





A D T

### 802.11n (20MHz)

#### TEST MDOE A

CHANNEL	CHANNEL FREQUENCY (MHz)	6dB BANDWIDTH (MHz)		MINIMUM LIMIT (MHz)	PASS / FAIL
		CHAIN 0	CHAIN 1		
1	2412	17.43	16.07	0.5	PASS
6	2437	17.64	15.41	0.5	PASS
11	2462	17.70	17.69	0.5	PASS

#### FOR CHAIN 0: CH 11

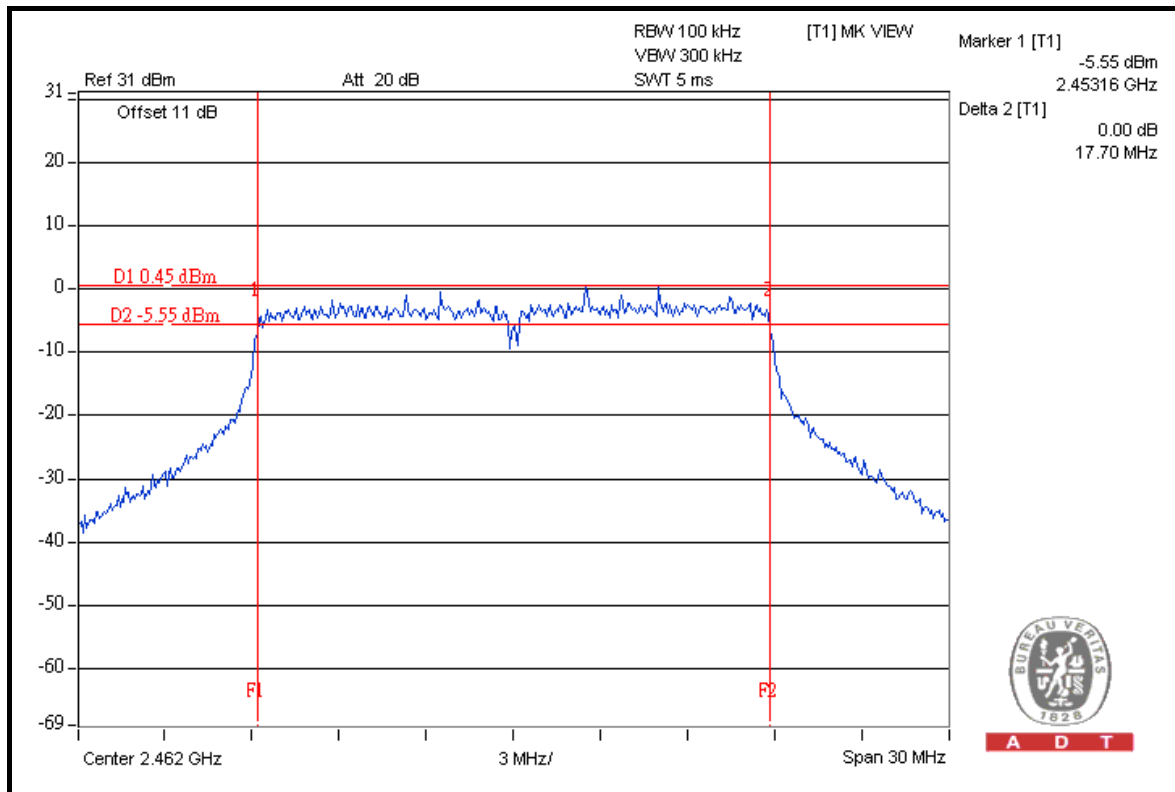



A D T

### TEST MDOE C

CHANNEL	CHANNEL FREQUENCY (MHz)	6dB BANDWIDTH (MHz)		MINIMUM LIMIT (MHz)	PASS / FAIL
		CHAIN 0	CHAIN 1		
1	2412	17.68	17.70	0.5	PASS
6	2437	17.70	17.71	0.5	PASS
11	2462	17.70	17.74	0.5	PASS

### FOR CHAIN 1: CH 11

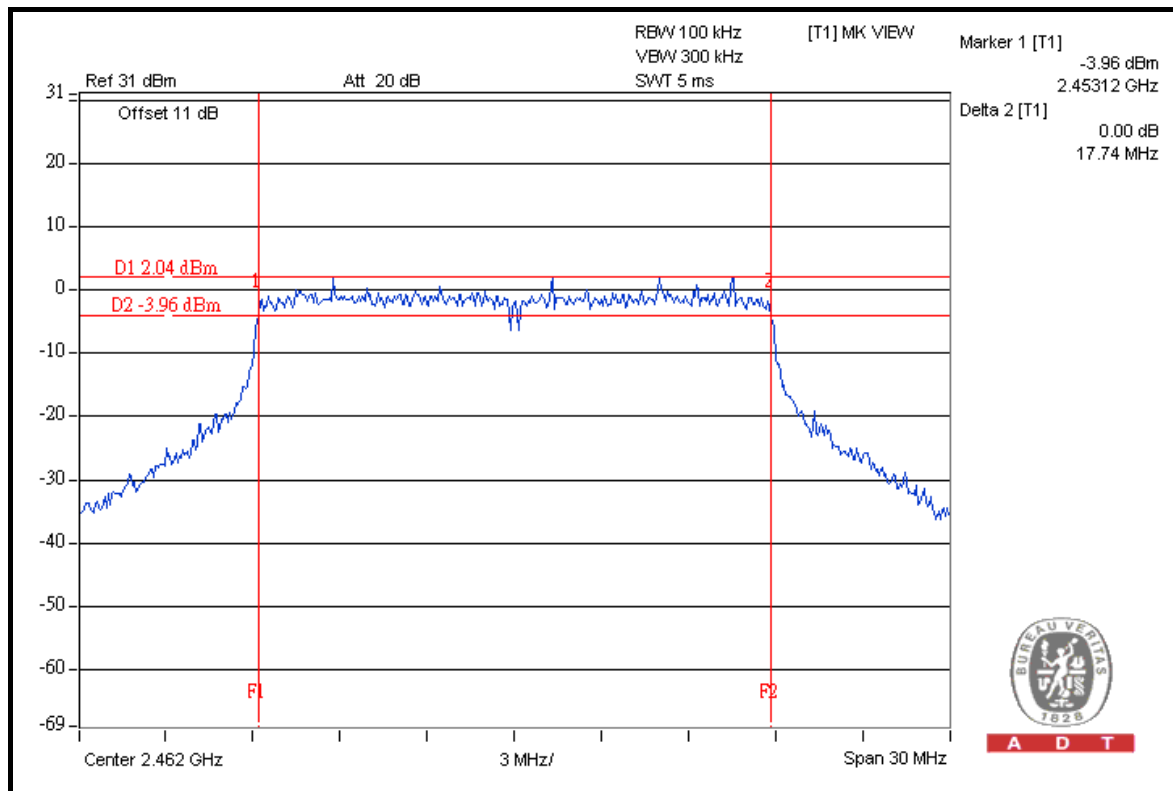



A D T

### 802.11n (40MHz)

#### TEST MODE A

CHANNEL	CHANNEL FREQUENCY (MHz)	6dB BANDWIDTH (MHz)		MINIMUM LIMIT (MHz)	PASS / FAIL
		CHAIN 0	CHAIN 1		
1	2422	33.29	36.51	0.5	PASS
4	2437	35.91	36.46	0.5	PASS
7	2452	35.86	34.45	0.5	PASS

#### FOR CHAIN 1: CH 1

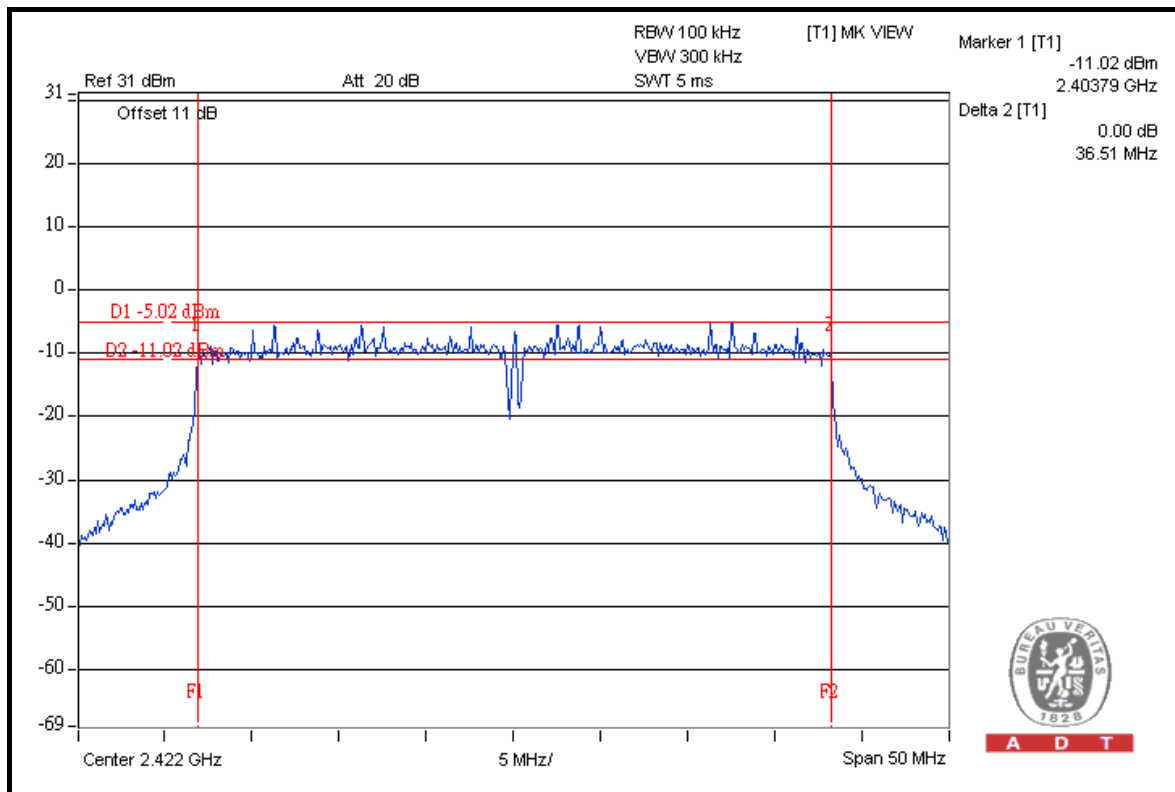



A D T

### TEST MODE C

CHANNEL	CHANNEL FREQUENCY (MHz)	6dB BANDWIDTH (MHz)		MINIMUM LIMIT (MHz)	PASS / FAIL
		CHAIN 0	CHAIN 1		
1	2422	36.07	36.45	0.5	PASS
4	2437	36.45	36.46	0.5	PASS
7	2452	36.47	36.45	0.5	PASS

### FOR CHAIN 0: CH 7

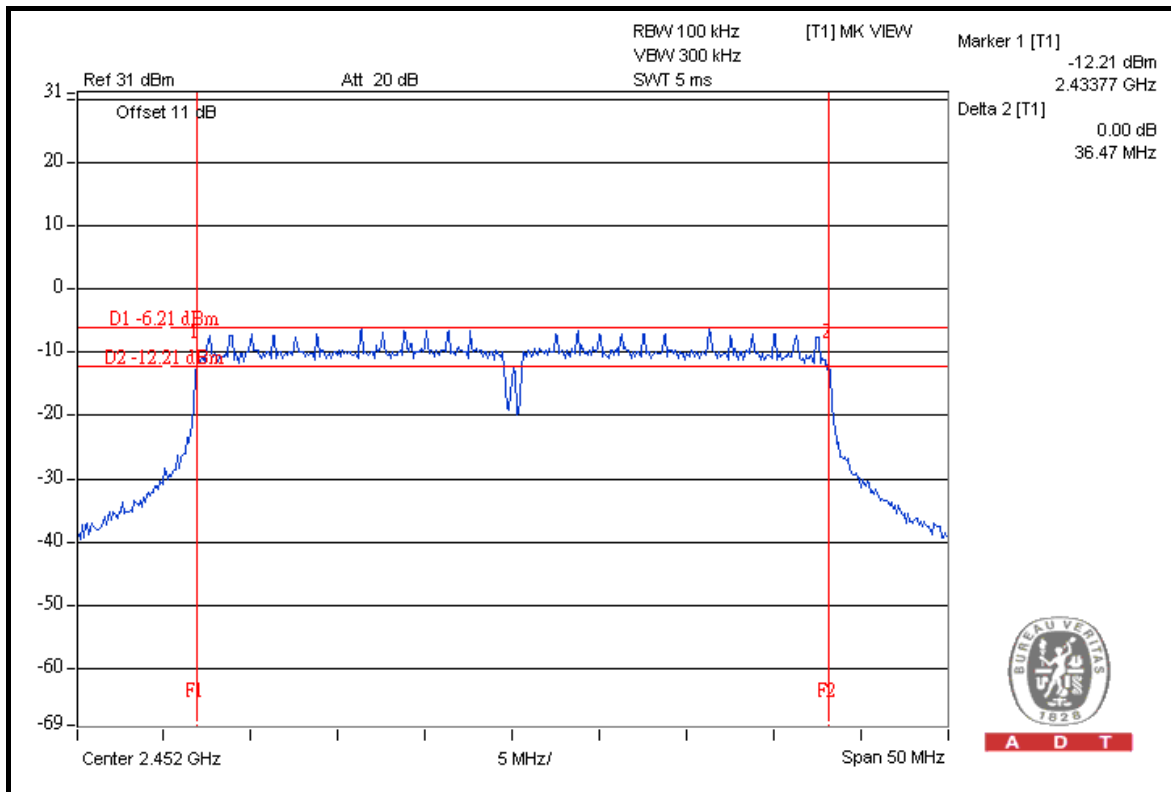

A D T



A D T

#### 4.4 MAXIMUM OUTPUT POWER

##### 4.4.1 LIMITS OF MAXIMUM OUTPUT POWER MEASUREMENT

The Maximum Output Power Measurement is 30dBm.

##### 4.4.2 INSTRUMENTS

DESCRIPTION & MANUFACTURER	MODEL NO.	SERIAL NO.	DATE OF CALIBRATION	DUE DATE OF CALIBRATION
High Speed Peak Power Meter	ML2495A	0842014	Apr. 21, 2010	Apr. 20, 2011
Power Sensor	MA2411B	0738404	Apr. 21, 2010	Apr. 20, 2011

**Note:**

1. The calibration interval of the above test instruments is 12 months and the calibrations are traceable to NML/ROC and NIST/USA.
2. Measurement Bandwidth of ML2495A is 65MHz greater than 6dB bandwidth of emission.

##### 4.4.3 TEST PROCEDURES

A power sensor was used on the output port of the EUT. A power meter was used to read the response of the power sensor. Record the power level.

#### 4.4.4 DEVIATION FROM TEST STANDARD

No deviation

#### 4.4.5 TEST SETUP

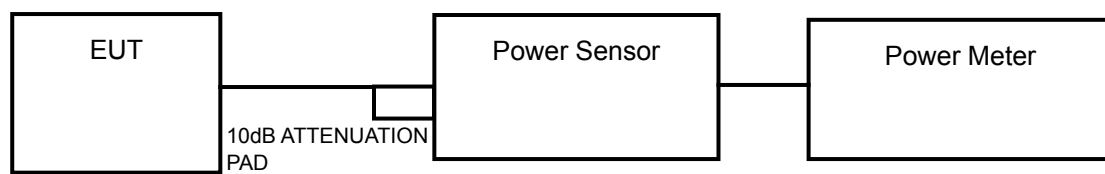

#### 4.4.6 EUT OPERATING CONDITIONS

Same as Item 4.3.6



#### 4.4.7 TEST RESULTS

##### 802.11b

##### TEST MODE A

CHAN.	CHAN. FREQ. (MHz)	POWER OUTPUT (dBm)		TOTAL POWER (mW)	TOTAL POWER (dBm)	POWER LIMIT (dBm)	PASS / FAIL
		CHAIN 0	CHAIN 1				
1	2412	19.5	19.3	174.2	22.4	29.5	PASS
6	2437	22.3	22.8	360.4	25.6	29.5	PASS
11	2462	19.2	19.0	162.6	22.1	29.5	PASS

##### TEST MODE C

CHAN.	CHAN. FREQ. (MHz)	POWER OUTPUT (dBm)		TOTAL POWER (mW)	TOTAL POWER (dBm)	POWER LIMIT (dBm)	PASS / FAIL
		CHAIN 0	CHAIN 1				
1	2412	22.1	22.3	332.0	25.2	30	PASS
6	2437	22.5	22.7	364.0	25.6	30	PASS
11	2462	21.0	21.3	260.8	24.2	30	PASS

##### 802.11g

##### TEST MODE A

CHAN.	CHAN. FREQ. (MHz)	POWER OUTPUT (dBm)		TOTAL POWER (mW)	TOTAL POWER (dBm)	POWER LIMIT (dBm)	PASS / FAIL
		CHAIN 0	CHAIN 1				
1	2412	21.0	21.8	277.2	24.4	29.5	PASS
6	2437	22.3	22.5	347.7	25.4	29.5	PASS
11	2462	21.4	21.7	285.9	24.6	29.5	PASS

##### TEST MODE C

CHAN.	CHAN. FREQ. (MHz)	POWER OUTPUT (dBm)		TOTAL POWER (mW)	TOTAL POWER (dBm)	POWER LIMIT (dBm)	PASS / FAIL
		CHAIN 0	CHAIN 1				
1	2412	22.3	22.5	347.7	25.4	30	PASS
6	2437	23.9	24.3	514.6	27.1	30	PASS
11	2462	22.8	23.2	399.5	26.0	30	PASS

##### NOTE:

##### TEST MODE A:

Directional gain = 2.4dBi + 4.31dBi = 6.5dBi > 6dBi, conducted power limit is reduced from 30dBm down to  $30 - (6.5 - 6) = 29.5$ dBm

##### TEST MODE C:

Directional gain = 0.7dBi + 3.9dBi = 5.6dBi < 6dBi, conducted power limit is not reduced.

**802.11n (20MHz)****TEST MODE A**

CHAN.	CHAN. FREQ. (MHz)	POWER OUTPUT (dBm)		TOTAL POWER (mW)	TOTAL POWER (dBm)	POWER LIMIT (dBm)	PASS / FAIL
		CHAIN 0	CHAIN 1				
1	2412	20.2	22.0	263.2	24.2	30	PASS
6	2437	22.2	22.3	335.8	25.3	30	PASS
11	2462	19.5	19.9	186.8	22.7	30	PASS

**TEST MODE C**

CHAN.	CHAN. FREQ. (MHz)	POWER OUTPUT (dBm)		TOTAL POWER (mW)	TOTAL POWER (dBm)	POWER LIMIT (dBm)	PASS / FAIL
		CHAIN 0	CHAIN 1				
1	2412	21.5	22.2	307.2	24.9	30	PASS
6	2437	23.8	24.2	502.9	27.0	30	PASS
11	2462	23.2	23.3	422.7	26.3	30	PASS

**802.11n (40MHz)****TEST MODE A**

CHAN.	CHAN. FREQ. (MHz)	POWER OUTPUT (dBm)		TOTAL POWER (mW)	TOTAL POWER (dBm)	POWER LIMIT (dBm)	PASS / FAIL
		CHAIN 0	CHAIN 1				
1	2422	19.8	20.5	207.7	23.2	30	PASS
4	2437	21.1	21.6	273.4	24.4	30	PASS
7	2452	15.5	16.3	78.1	18.9	30	PASS

**TEST MODE C**

CHAN.	CHAN. FREQ. (MHz)	POWER OUTPUT (dBm)		TOTAL POWER (mW)	TOTAL POWER (dBm)	POWER LIMIT (dBm)	PASS / FAIL
		CHAIN 0	CHAIN 1				
1	2422	17.5	17.8	116.5	20.7	30	PASS
4	2437	21.9	22.4	328.7	25.2	30	PASS
7	2452	17.3	17.4	108.7	20.4	30	PASS





A D T

## 4.5 POWER SPECTRAL DENSITY MEASUREMENT

### 4.5.1 LIMITS OF POWER SPECTRAL DENSITY MEASUREMENT

The Maximum of Power Spectral Density Measurement is 8dBm.

### 4.5.2 TEST INSTRUMENTS

DESCRIPTION & MANUFACTURER	MODEL NO.	SERIAL NO.	DATE OF CALIBRATION	DUE DATE OF CALIBRATION
SPECTRUM ANALYZER R&S	FSP40	100039	Jan. 11, 2010	Jan. 10, 2011

**NOTE:** The calibration interval of the above test instruments is 12 months and the calibrations are traceable to NML/ROC and NIST/USA.

### 4.5.3 TEST PROCEDURE

The transmitter output was connected to the spectrum analyzer through an attenuator, the bandwidth of the fundamental frequency was measured with the spectrum analyzer using 3kHz RBW and 30kHz VBW, set sweep time = span/3kHz. The power spectral density was measured and recorded.

The sweep time is allowed to be longer than span/3kHz for a full response of the mixer in the spectrum analyzer.

#### 4.5.4 DEVIATION FROM TEST STANDARD

No deviation

#### 4.5.5 TEST SETUP

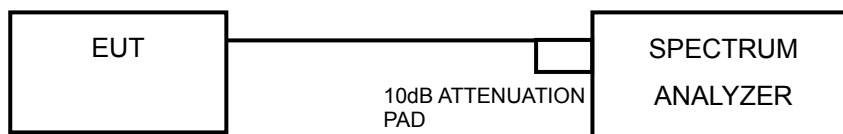

#### 4.5.6 EUT OPERATING CONDITION

Same as Item 4.3.6



A D T

### 4.5.7 TEST RESULTS

802.11b

#### TEST MODE A

CHAN.	CHAN. FREQ. (MHz)	RF POWER LEVEL IN 3kHz BW (dBm)		TOTAL POWER DENSITY (dBm)	MAX. LIMIT (dBm)	PASS / FAIL
		CHAIN 0	CHAIN 1			
1	2412	-8.0	-8.0	-5.0	7.5	PASS
6	2437	-5.0	-4.6	-1.8	7.5	PASS
11	2462	-8.2	-8.2	-5.2	7.5	PASS

\*\*Directional gain = 2.4dBi + 4.31dBi = 6.5dBi > 6dBi, Power Density limit is reduced from 8dBm down to 8-(6.5-6)=7.5dBm

#### FOR CHAIN 1: CH 6

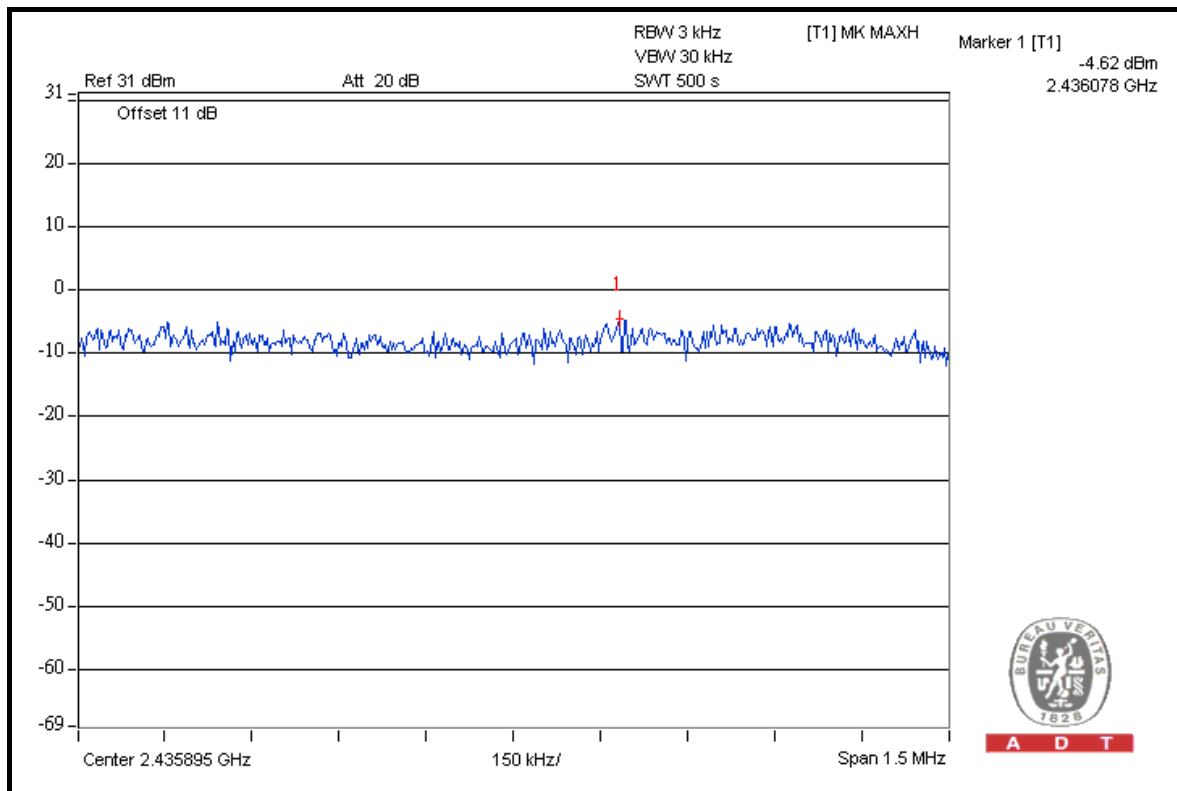

A D T



A D T

### TEST MODE C

CHAN.	CHAN. FREQ. (MHz)	RF POWER LEVEL IN 3kHz BW (dBm)		TOTAL POWER DENSITY (dBm)	MAX. LIMIT (dBm)	PASS / FAIL
		CHAIN 0	CHAIN 1			
1	2412	-5.7	-5.2	-2.4	8	PASS
6	2437	-5.2	-4.5	-1.8	8	PASS
11	2462	-6.8	-6.0	-3.4	8	PASS

\*\*Directional gain =  $0.7\text{dBi} + 3.9\text{dBi} = 5.6\text{dBi} < 6\text{dBi}$ , Power Density limit is not reduced.

### FOR CHAIN 1: CH 6

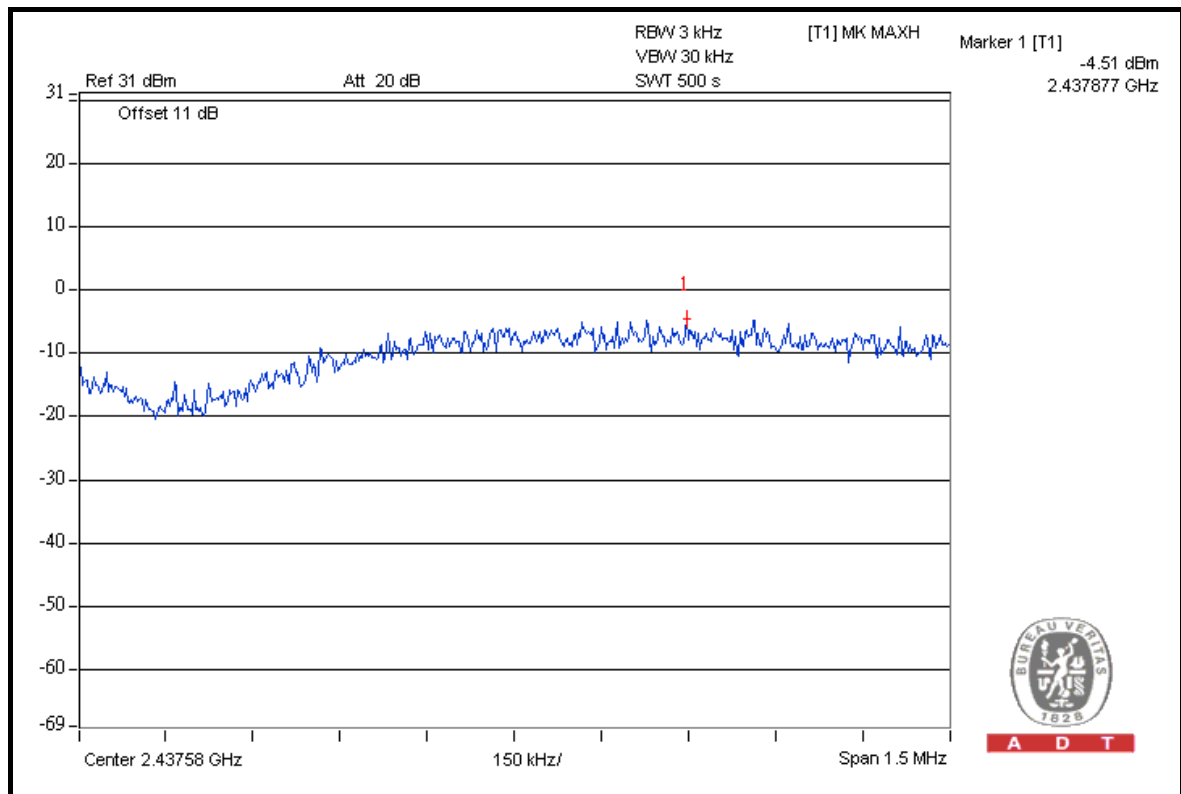



A D T

### 802.11g

### TEST MODE A

CHAN.	CHAN. FREQ. (MHz)	RF POWER LEVEL IN 3kHz BW (dBm)		TOTAL POWER DENSITY (dBm)	MAX. LIMIT (dBm)	PASS / FAIL
		CHAIN 0	CHAIN 1			
1	2412	-7.7	1.9	2.4	7.5	PASS
6	2437	-9.6	1.6	1.9	7.5	PASS
11	2462	-8.7	2.5	2.8	7.5	PASS

\*\*Directional gain = 2.4dBi + 4.31dBi = 6.5dBi > 6dBi, Power Density limit is reduced from 8dBm down to 8-(6.5-6)=7.5dBm

### FOR CHAIN 1: CH 11

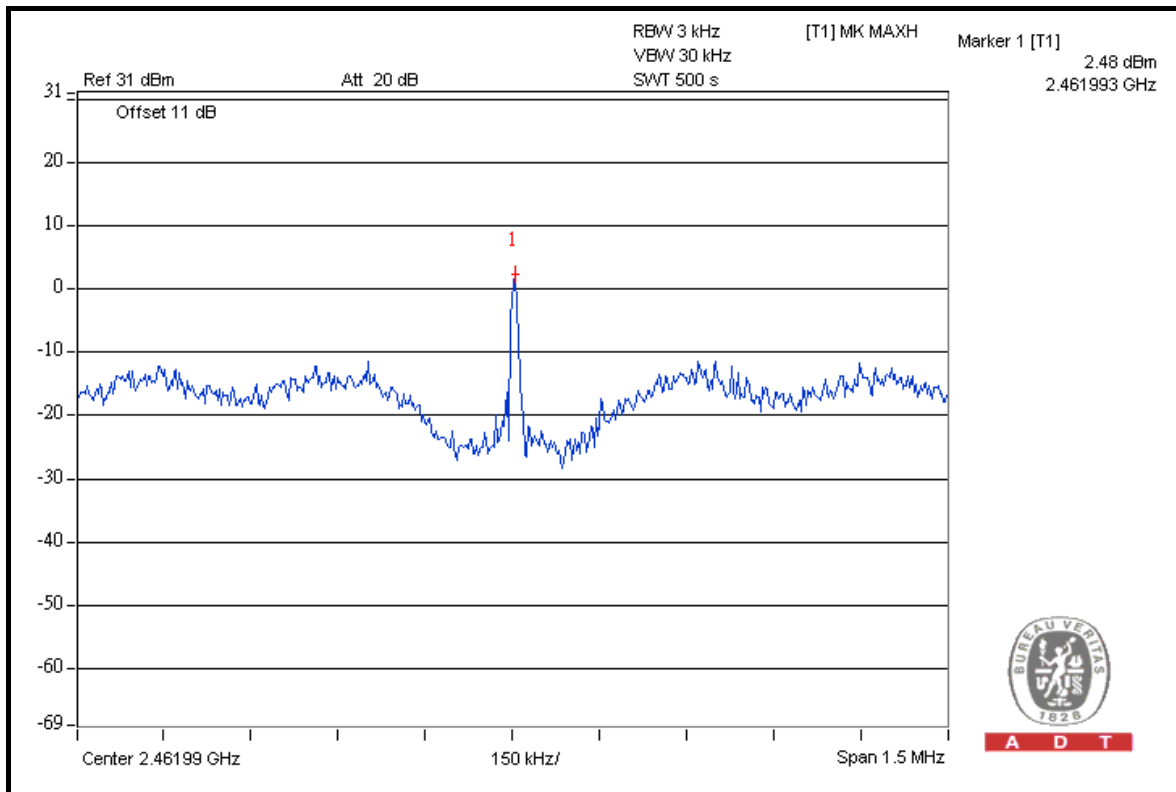

A D T



A D T

### TEST MODE C

CHAN.	CHAN. FREQ. (MHz)	RF POWER LEVEL IN 3kHz BW (dBm)		TOTAL POWER DENSITY (dBm)	MAX. LIMIT (dBm)	PASS / FAIL
		CHAIN 0	CHAIN 1			
1	2412	-11.8	-12.4	-9.1	8	PASS
6	2437	-10.4	-10.6	-7.5	8	PASS
11	2462	-11.3	-11.8	-8.5	8	PASS

\*\*Directional gain = 0.7dBi + 3.9dBi = 5.6dBi < 6dBi, Power Density limit is not reduced.

### FOR CHAIN 0: CH 6

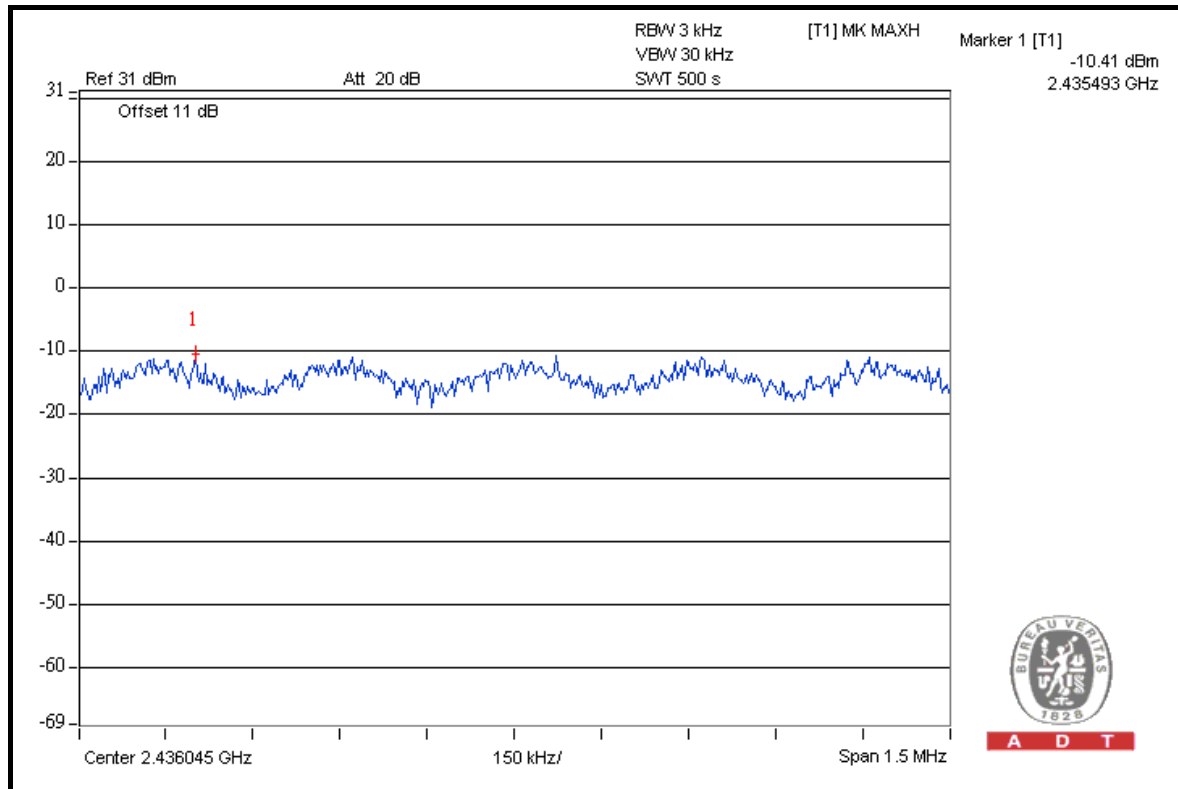

A D T



A D T

### 802.11n (20MHz)

#### TEST MODE A

CHAN.	CHAN. FREQ. (MHz)	RF POWER LEVEL IN 3kHz BW (dBm)		TOTAL POWER DENSITY (dBm)	MAX. LIMIT (dBm)	PASS / FAIL
		CHAIN 0	CHAIN 1			
1	2412	-6.8	2.3	2.8	8	PASS
6	2437	-4.9	1.8	2.6	8	PASS
11	2462	-10.1	-5.4	-4.1	8	PASS

#### FOR CHAIN 1: CH 1

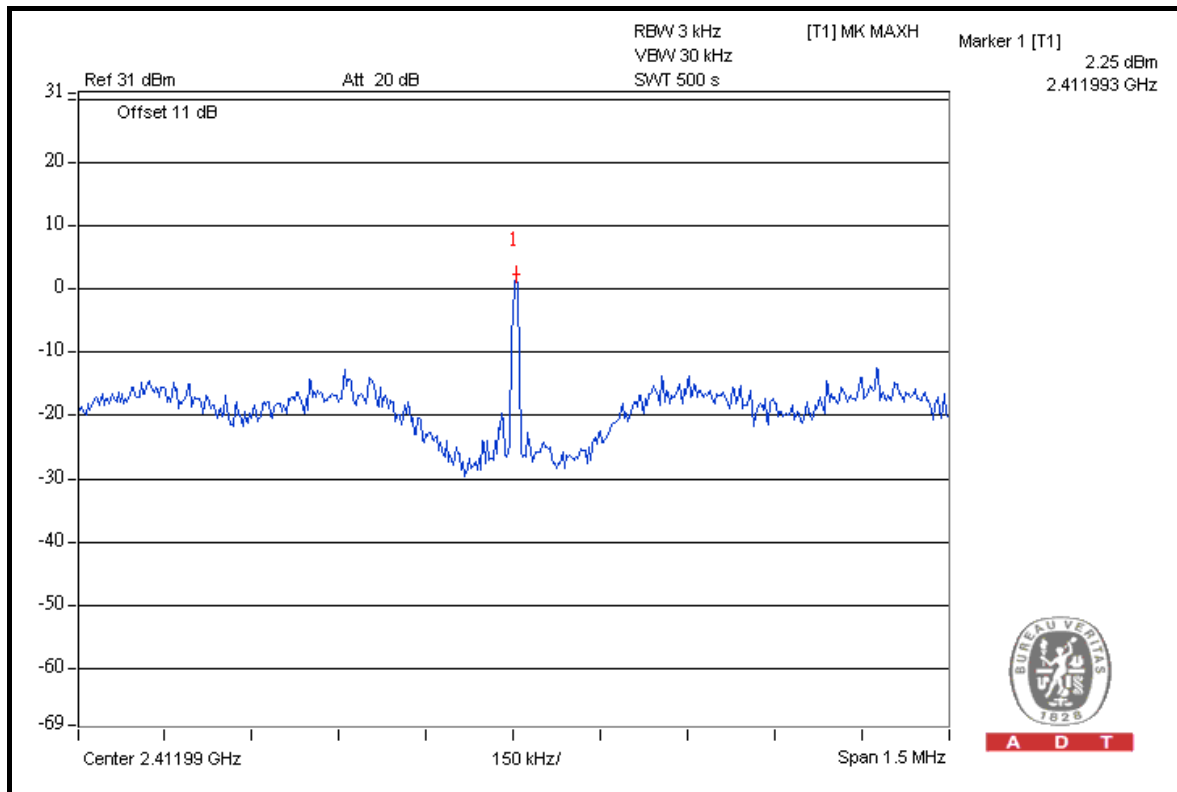



A D T

### TEST MODE C

CHAN.	CHAN. FREQ. (MHz)	RF POWER LEVEL IN 3kHz BW (dBm)		TOTAL POWER DENSITY (dBm)	MAX. LIMIT (dBm)	PASS / FAIL
		CHAIN 0	CHAIN 1			
1	2412	-12.9	-13.0	-9.9	8	PASS
6	2437	-10.4	-10.8	-7.6	8	PASS
11	2462	-11.1	-11.7	-8.4	8	PASS

### FOR CHAIN 0: CH 6

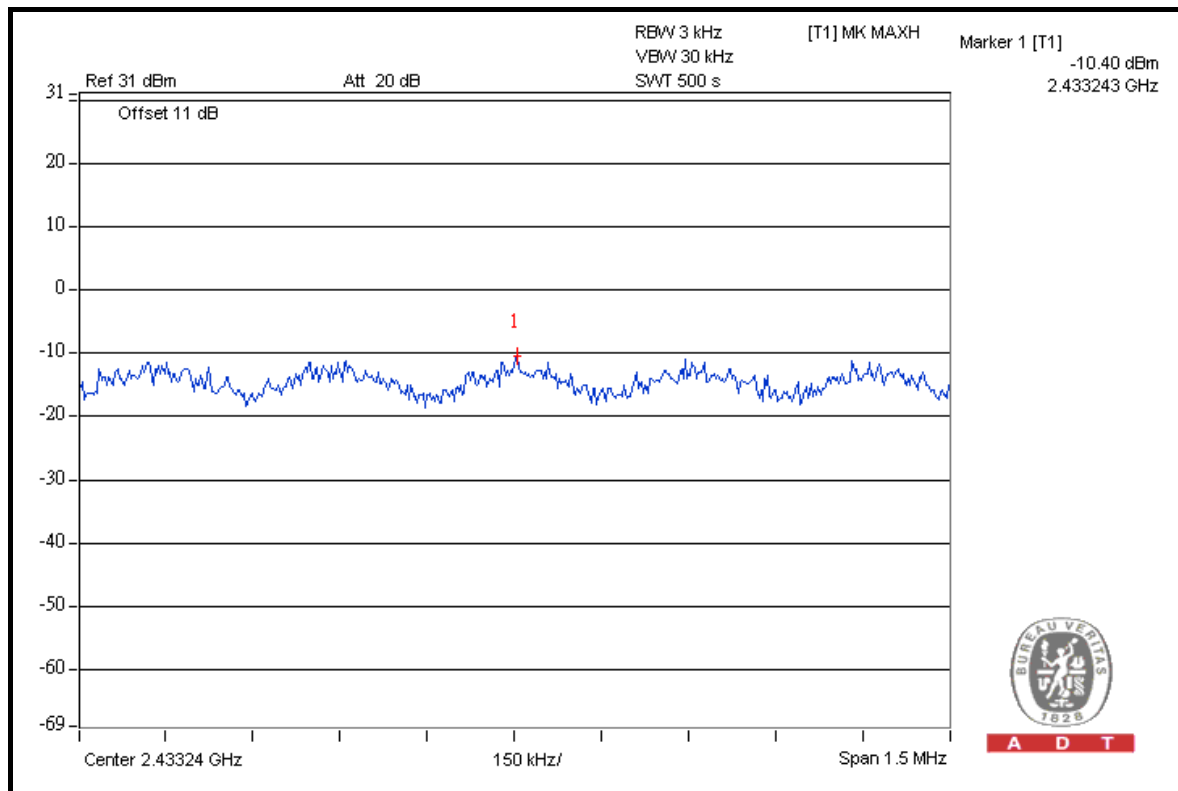

A D T





A D T

802.11n (40MHz)  
TEST MODE A

CHAN.	CHAN. FREQ. (MHz)	RF POWER LEVEL IN 3kHz BW (dBm)		TOTAL POWER DENSITY (dBm)	MAX. LIMIT (dBm)	PASS / FAIL
		CHAIN 0	CHAIN 1			
1	2422	-11.3	-7.3	-5.8	8	PASS
4	2437	-9.9	-6.4	-4.8	8	PASS
7	2452	-9.0	-7.2	-5.0	8	PASS

FOR CHAIN 1: CH 4

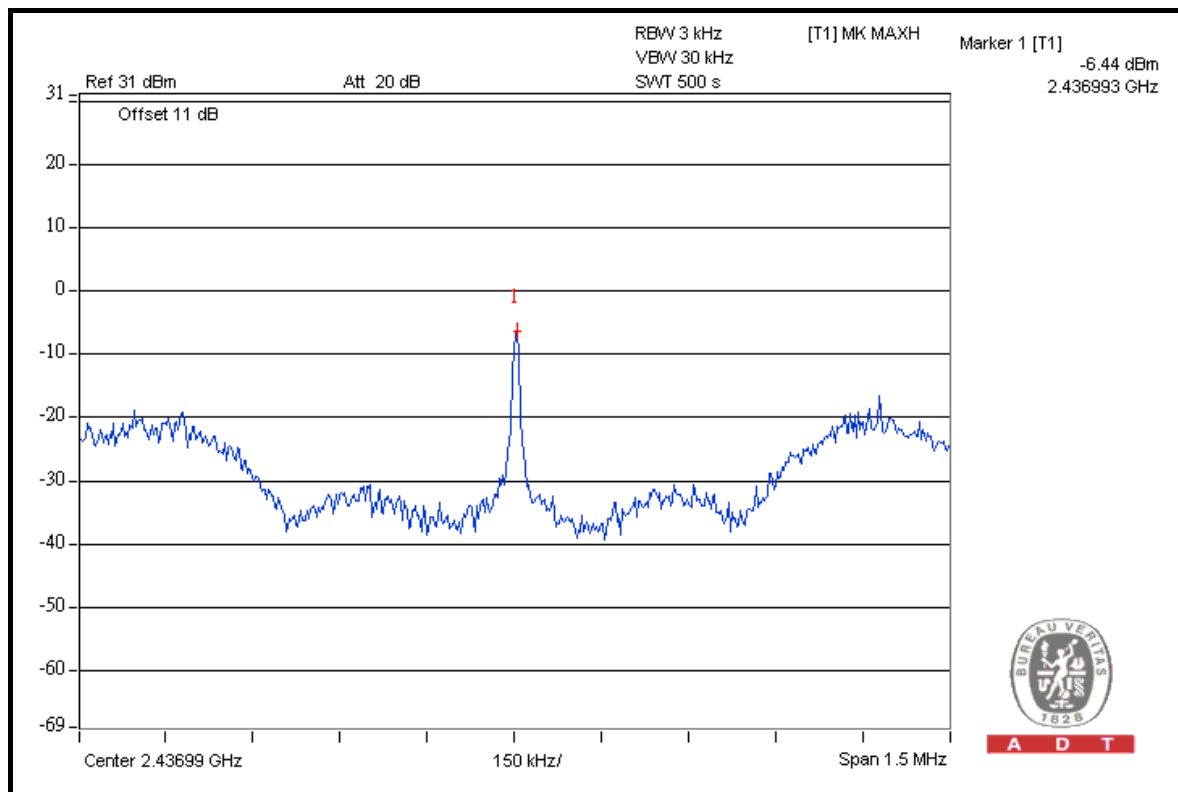

A D T



A D T

### TEST MODE C

CHAN.	CHAN. FREQ. (MHz)	RF POWER LEVEL IN 3kHz BW (dBm)		TOTAL POWER DENSITY (dBm)	MAX. LIMIT (dBm)	PASS / FAIL
		CHAIN 0	CHAIN 1			
1	2422	-20.3	-20.0	-17.1	8	PASS
4	2437	-15.7	-15.3	-12.5	8	PASS
7	2452	-20.6	-20.2	-17.4	8	PASS

### FOR CHAIN 1: CH 4

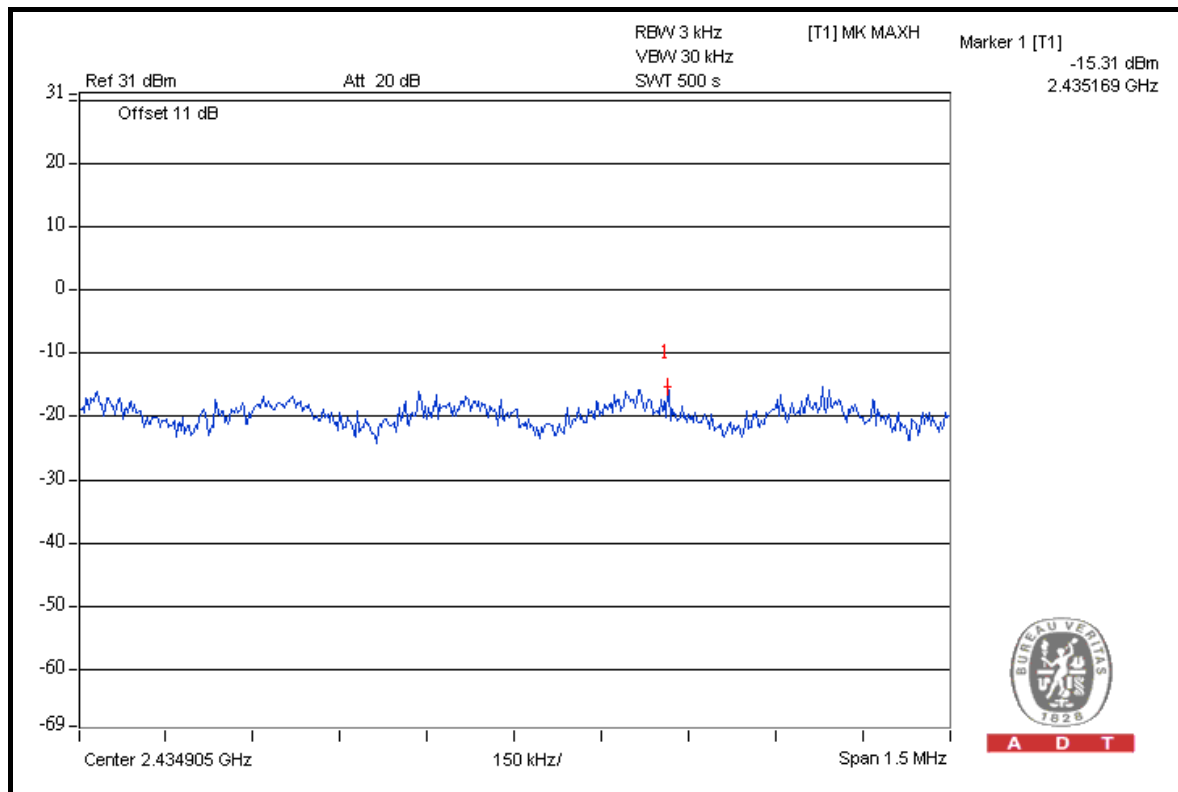



**A D T**

## 4.6 BAND EDGES MEASUREMENT

### 4.6.1 LIMITS OF BAND EDGES MEASUREMENT

Below –20dB of the highest emission level of operating band (in 100kHz Resolution Bandwidth).

### 4.6.2 TEST INSTRUMENTS

DESCRIPTION & MANUFACTURER	MODEL NO.	SERIAL NO.	DATE OF CALIBRATION	CALIBRATED UNTIL
Test Receiver ROHDE & SCHWARZ	ESI7	838496/016	Dec. 29, 2009	Dec. 28, 2010
Spectrum Analyzer ROHDE & SCHWARZ	FSP40	100039	Jan. 11, 2010	Jan. 10, 2011
BILOG Antenna SCHWARZBECK	VULB9168	9168-155	Apr. 28, 2010	Apr. 27, 2011
HORN Antenna SCHWARZBECK	BBHA 9120D	9120D-408	Jan. 05, 2010	Jan. 04, 2011
HORN Antenna SCHWARZBECK	BBHA 9170	BBHA9170242	Dec. 25, 2009	Dec. 24, 2010
Preamplifier Agilent	8449B	3008A01961	Nov. 04, 2009	Nov. 03, 2010
Preamplifier Agilent	8447D	2944A10738	Nov. 04, 2009	Nov. 03, 2010
RF signal cable HUBER+SUHNNER	SUCOFLEX 104	238141/4	May 14, 2010	May 13, 2011
RF signal cable HUBER+SUHNNER	SUCOFLEX 104	12738/6	May 14, 2010	May 13, 2011
Software ADT.	ADT_Radiated_ V7.6.15.9.2	NA	NA	NA
Antenna Tower inn-co GmbH	MA 4000	010303	NA	NA
Antenna Tower Controller inn-co GmbH	CO2000	019303	NA	NA
Turn Table ADT.	TT100.	TT93021704	NA	NA
Turn Table Controller ADT.	SC100.	SC93021704	NA	NA

**NOTE:** The calibration interval of the above test instruments is 12 months and the calibrations are traceable to NML/ROC and NIST/USA.



A D T

#### 4.6.3 TEST PROCEDURE

- a. The EUT was placed on the top of a rotating table 0.8 meters above the ground at a 3 meter semi-anechoic chamber. The table was rotated 360 degrees to determine the position of the highest radiation.
- b. The EUT was set 3 meters away from the interference-receiving antenna, which was mounted on the top of a variable-height antenna tower.
- c. The antenna is a broadband antenna, and its height is varied from one meter to four meters above the ground to determine the maximum value of the field strength. Both horizontal and vertical polarizations of the antenna are set to make the measurement.
- d. For each suspected emission, the EUT was arranged to its worst case and then the antenna was tuned to heights from 1 meter to 4 meters and the rotatable table was turned from 0 degrees to 360 degrees to find the maximum reading.
- e. Set both RBW and VBW of spectrum analyzer to 100kHz and 300kHz with suitable frequency span including 100MHz bandwidth from band edge. The band edges was measured and recorded.

The spectrum plots (Peak RBW = 100kHz, VBW = 300kHz) are attached on the following pages.

**NOTE:** The resolution bandwidth of test receiver/spectrum analyzer is 1MHz and the video bandwidth is 10Hz for Average detection (AV) at frequency above 1GHz.

#### 4.6.4 DEVIATION FROM TEST STANDARD

No deviation

#### 4.6.5 EUT OPERATING CONDITION

Same as Item 4.3.6



#### 4.6.6 TEST RESULTS

The spectrum plots are attached on the following pages. D1 line indicates the highest level, and D2 line indicates the 20dB offset below D1. It shows compliance with the requirement in part 15.247(d).

#### 802.11b

#### TEST MODE A

#### RESTRICT BAND (2310 ~ 2390 MHz)

FREQUENCY (MHz)	FUNDAMENTAL EMISSION (dBuV/m)	DELTA (dB)	MAXIMUM FIELD STRENGTH IN RESTRICT BAND (dBuV/m)	LIMIT (dBuV/m)
2412.00 (PK)	111.7	52.03	59.67	74.00
2412.00 (AV)	107.1	55.81	51.29	54.00

#### RESTRICT BAND (2483.5 ~ 2500 MHz)

FREQUENCY (MHz)	FUNDAMENTAL EMISSION (dBuV/m)	DELTA (dB)	MAXIMUM FIELD STRENGTH IN RESTRICT BAND (dBuV/m)	LIMIT (dBuV/m)
2462.00 (PK)	110.2	48.04	62.16	74.00
2462.00 (AV)	106.2	53.32	52.88	54.00

#### NOTE:

1. Delta = Amplitude between the peak of the fundamental and the peak of the band edge emission. Please check following 3 pages.
2. Maximum field strength in restrict band = Fundamental emission – Delta.



A D T

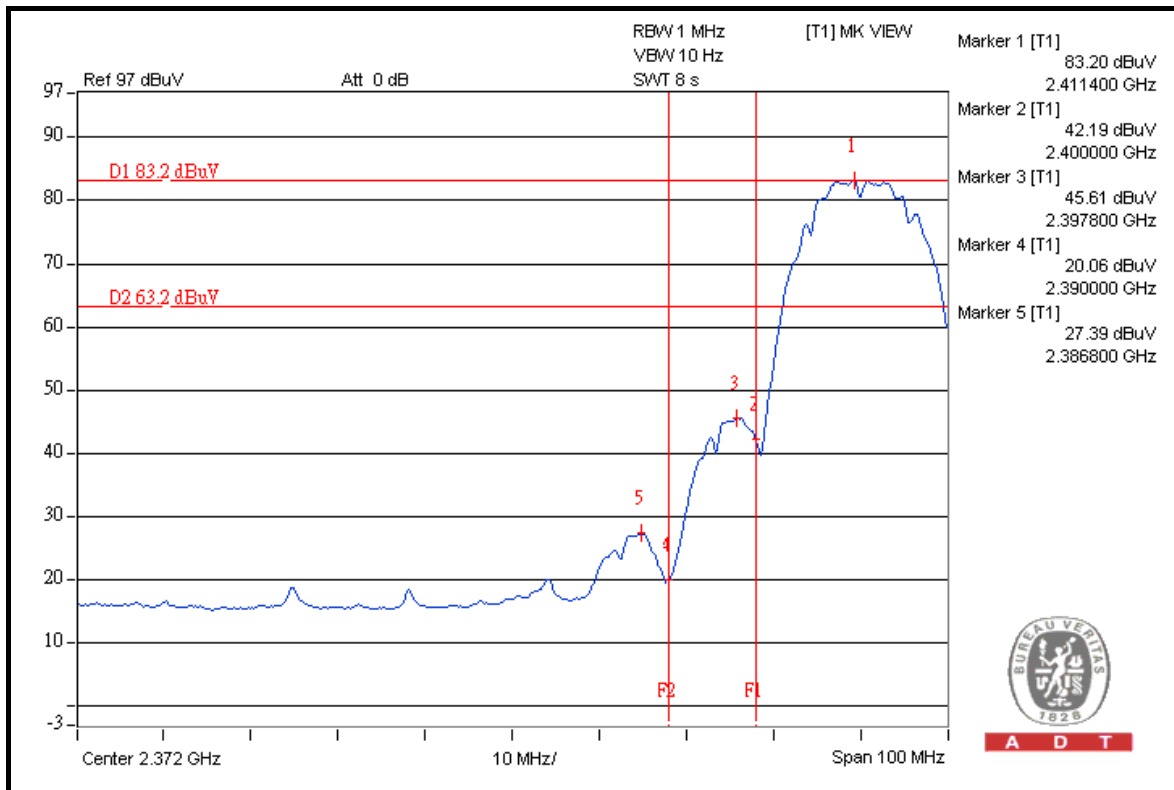
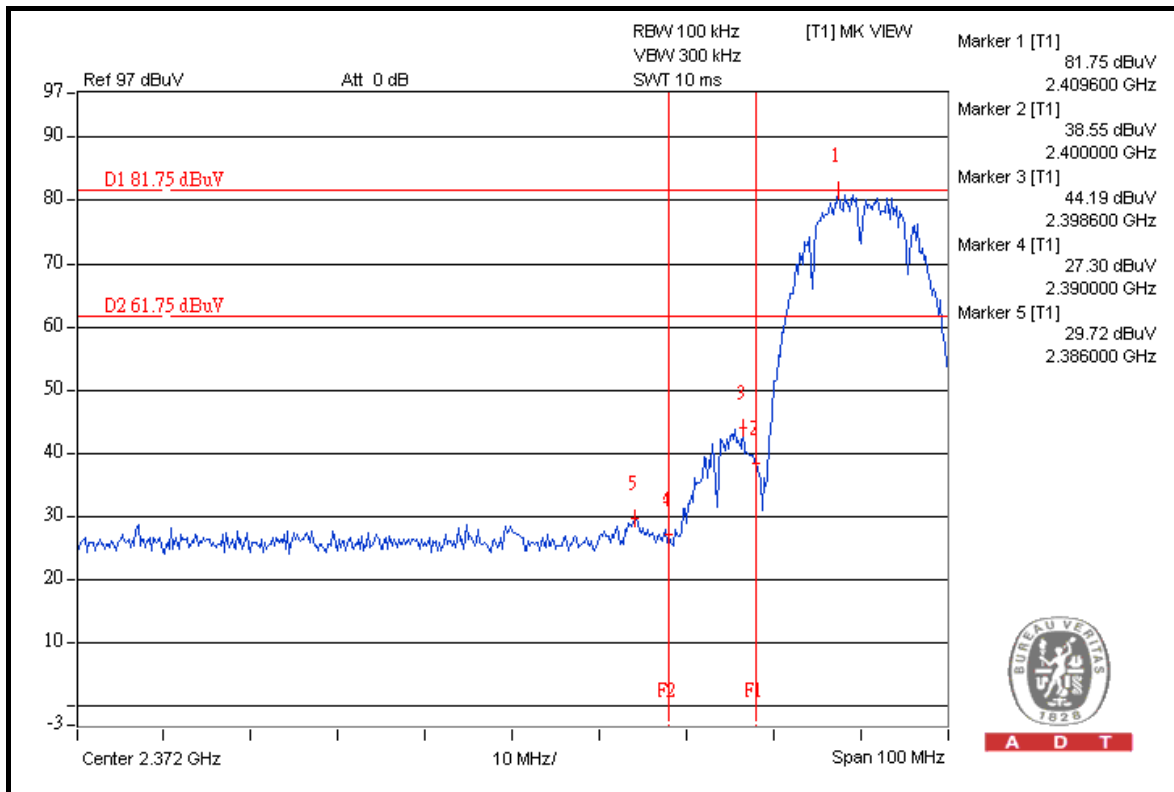



A D T

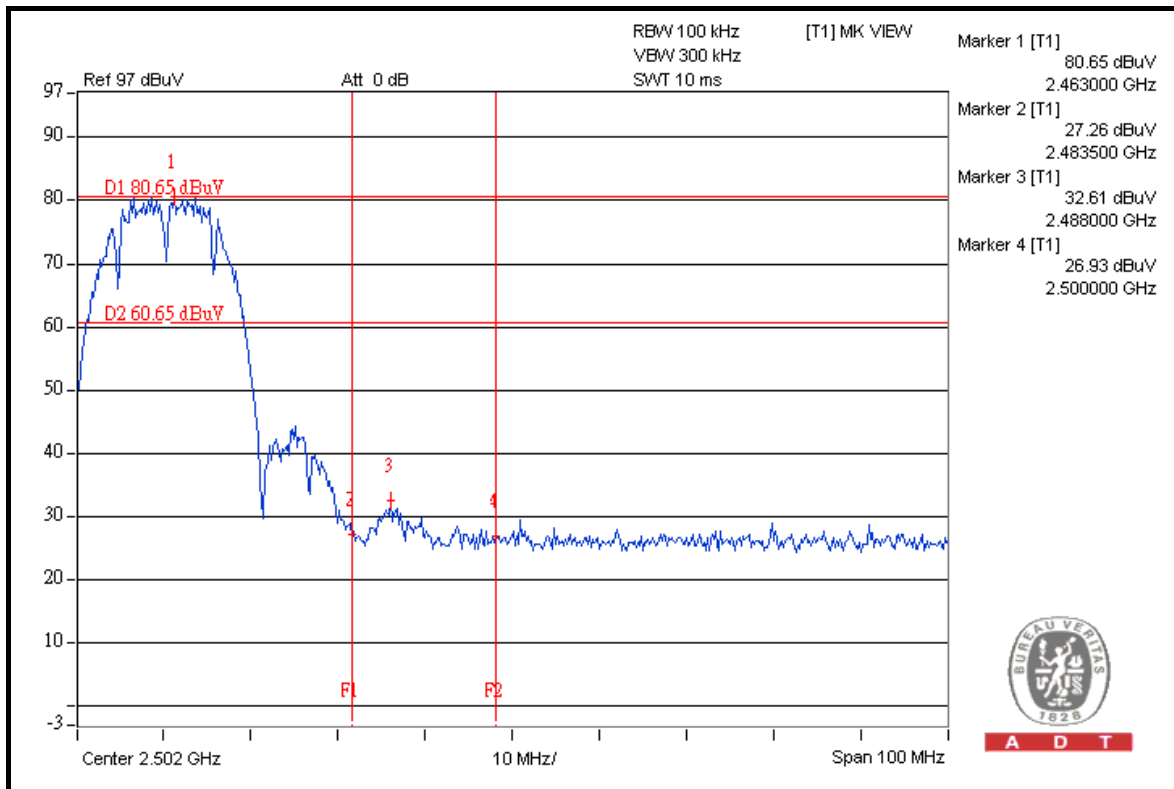
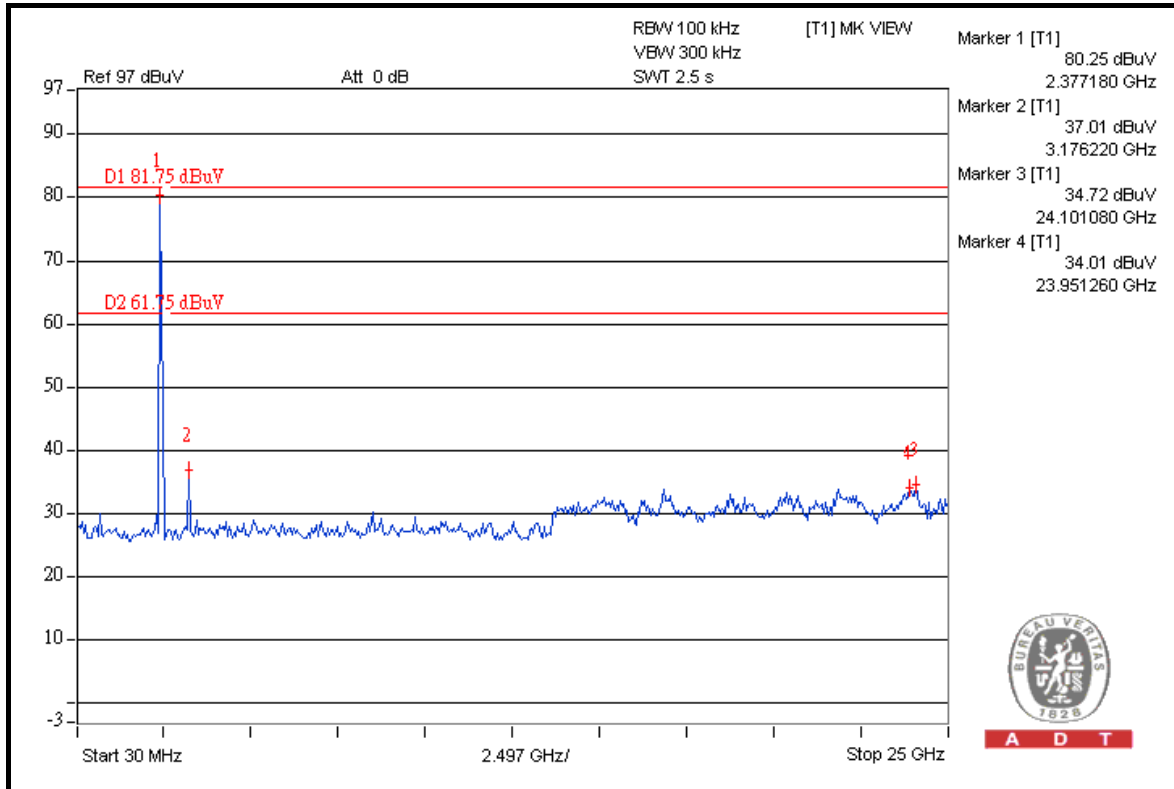



A D T

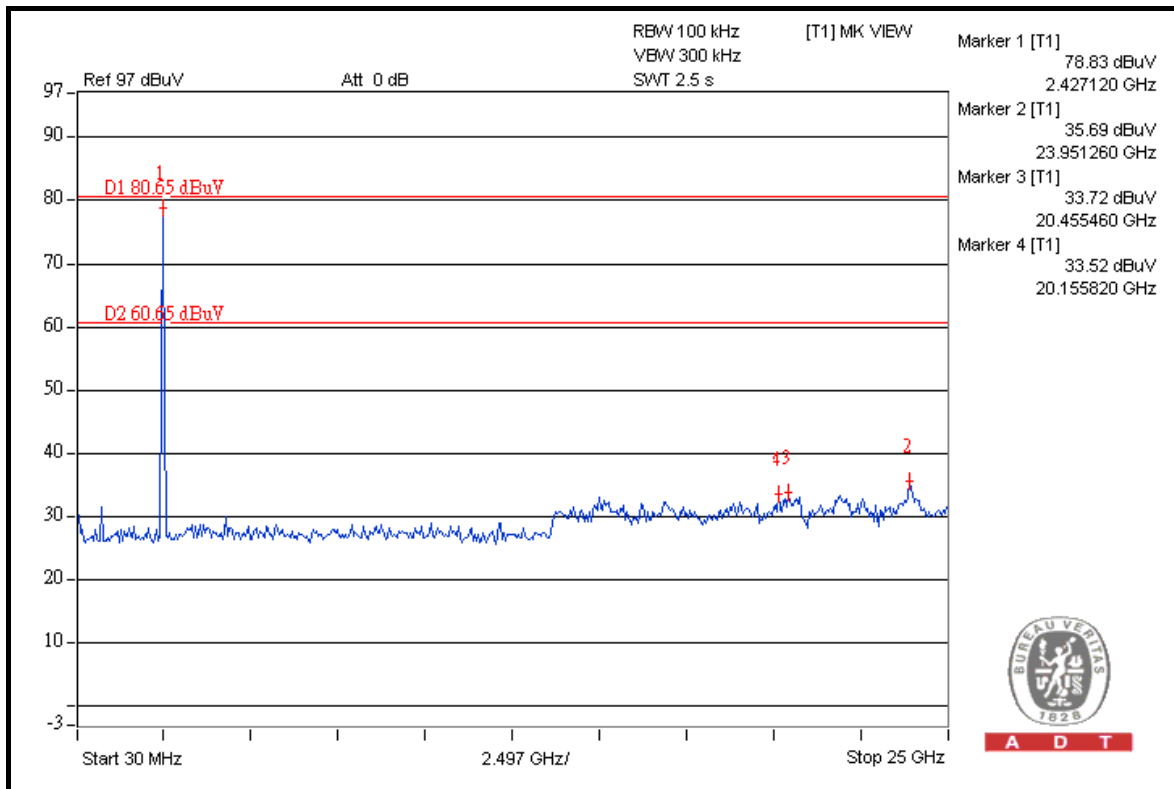
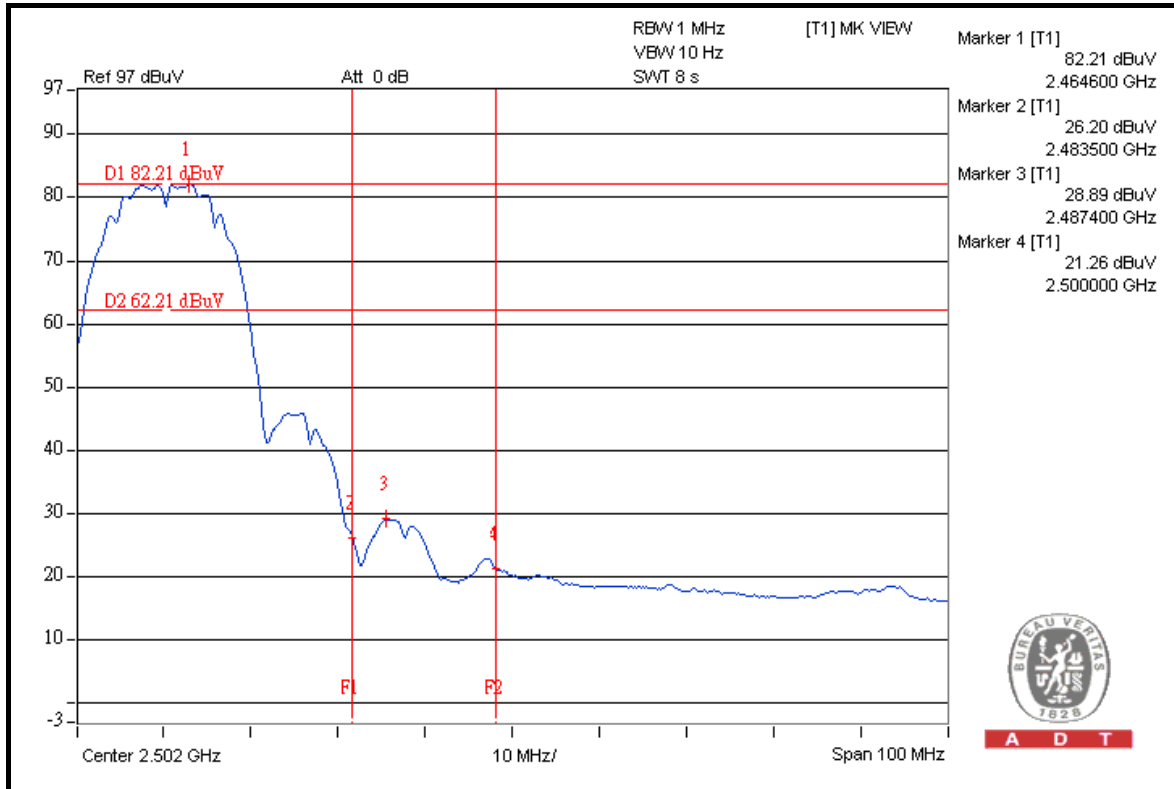





A D T

### TEST MODE C

#### RESTRICT BAND (2310 ~ 2390 MHz)

FREQUENCY (MHz)	FUNDAMENTAL EMISSION (dBuV/m)	DELTA (dB)	MAXIMUM FIELD STRENGTH IN RESTRICT BAND (dBuV/m)	LIMIT (dBuV/m)
2412.00 (PK)	115.2	56.73	58.47	74.00
2412.00 (AV)	111.2	62.02	49.18	54.00

#### RESTRICT BAND (2483.5 ~ 2500 MHz)

FREQUENCY (MHz)	FUNDAMENTAL EMISSION (dBuV/m)	DELTA (dB)	MAXIMUM FIELD STRENGTH IN RESTRICT BAND (dBuV/m)	LIMIT (dBuV/m)
2462.00 (PK)	113.8	56.07	57.73	74.00
2462.00 (AV)	109.9	62.16	47.74	54.00

#### NOTE:

1. Delta = Amplitude between the peak of the fundamental and the peak of the band edge emission. Please check following 3 pages.
2. Maximum field strength in restrict band = Fundamental emission – Delta.



A D T

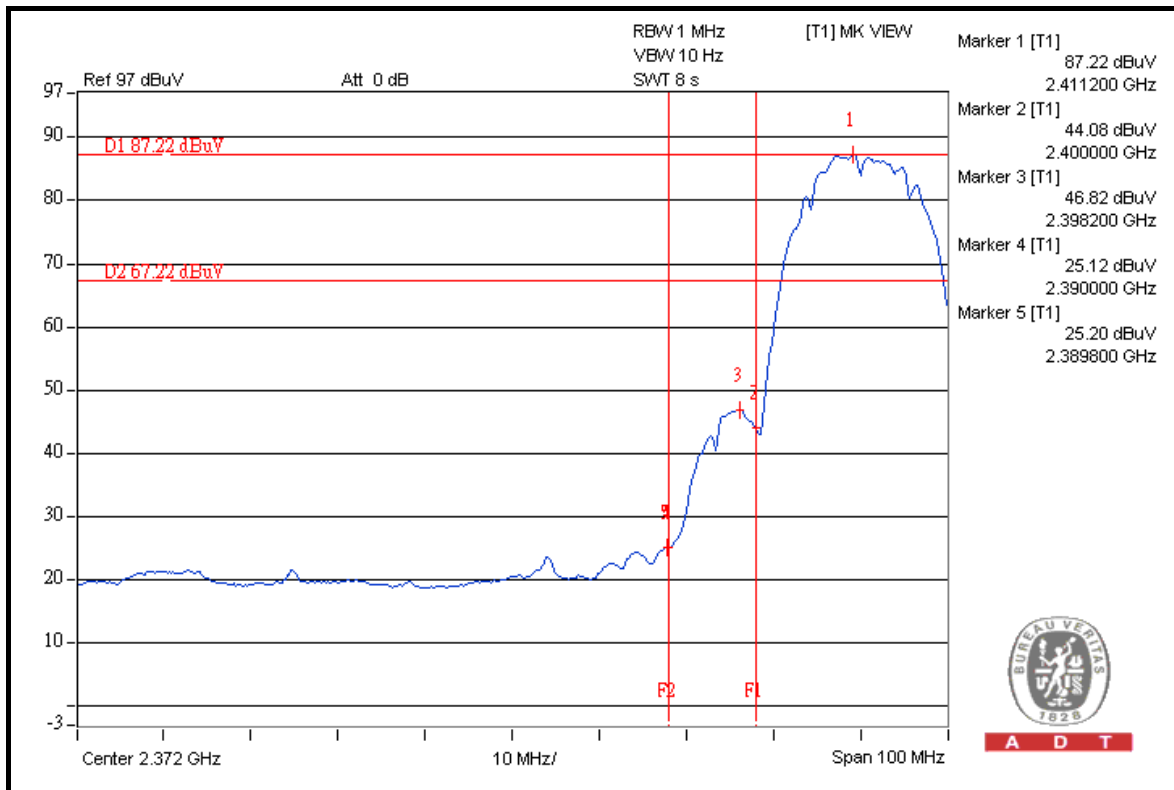
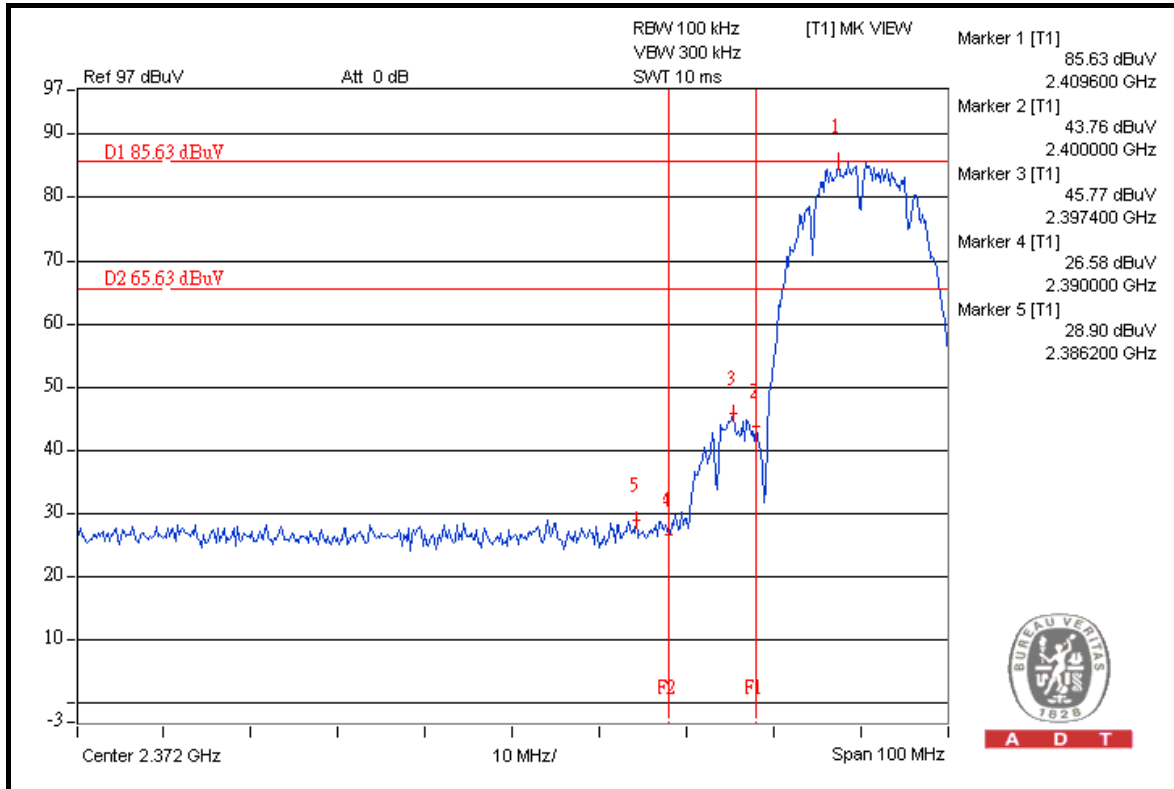



A D T

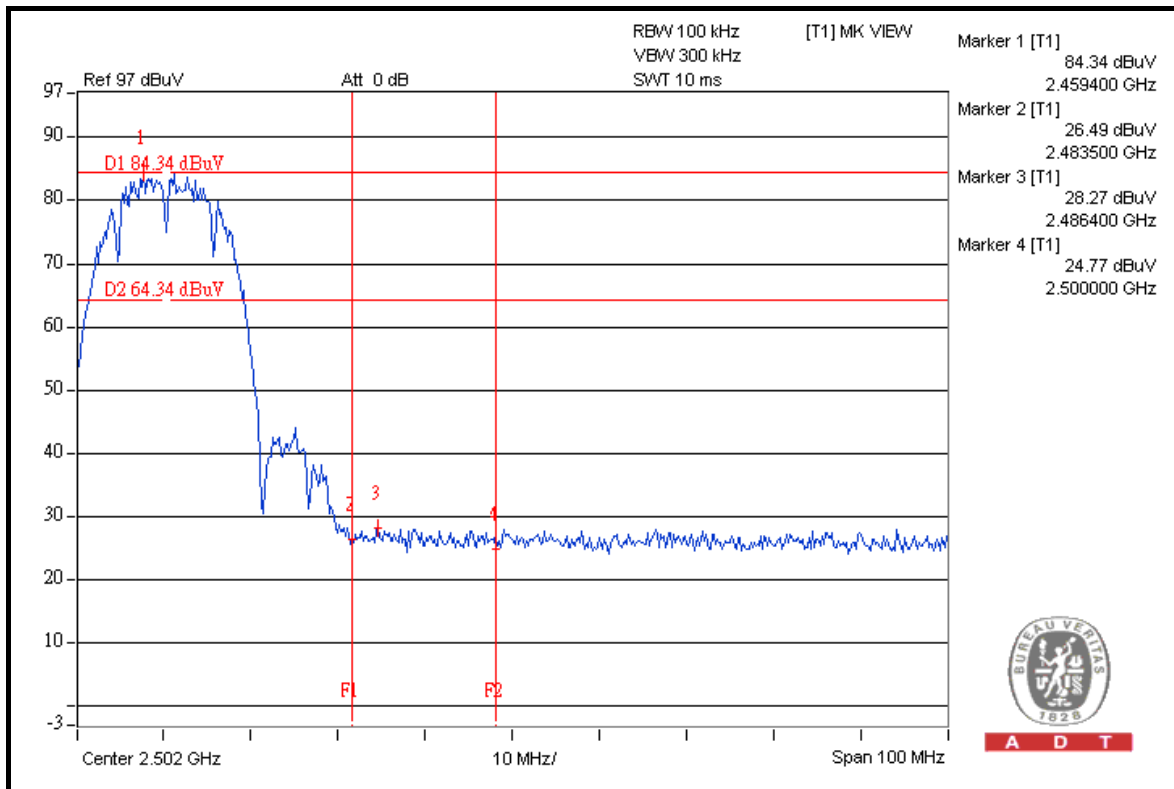
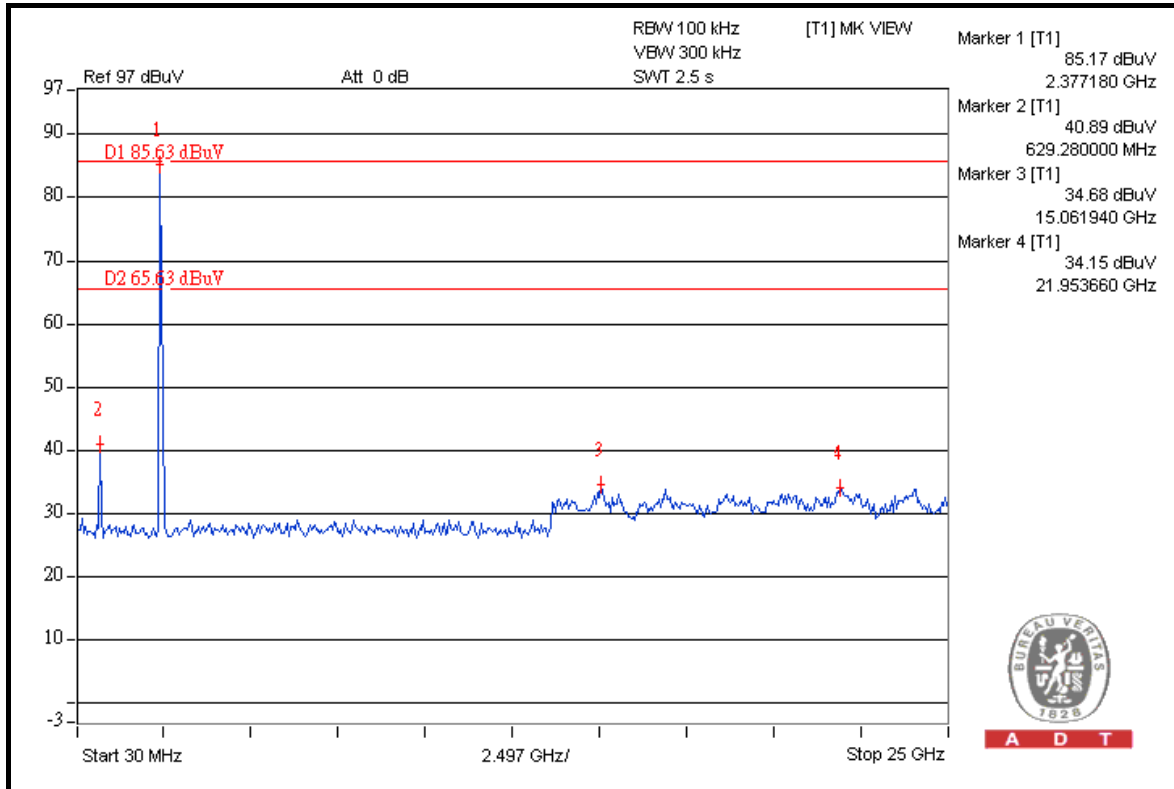



A D T

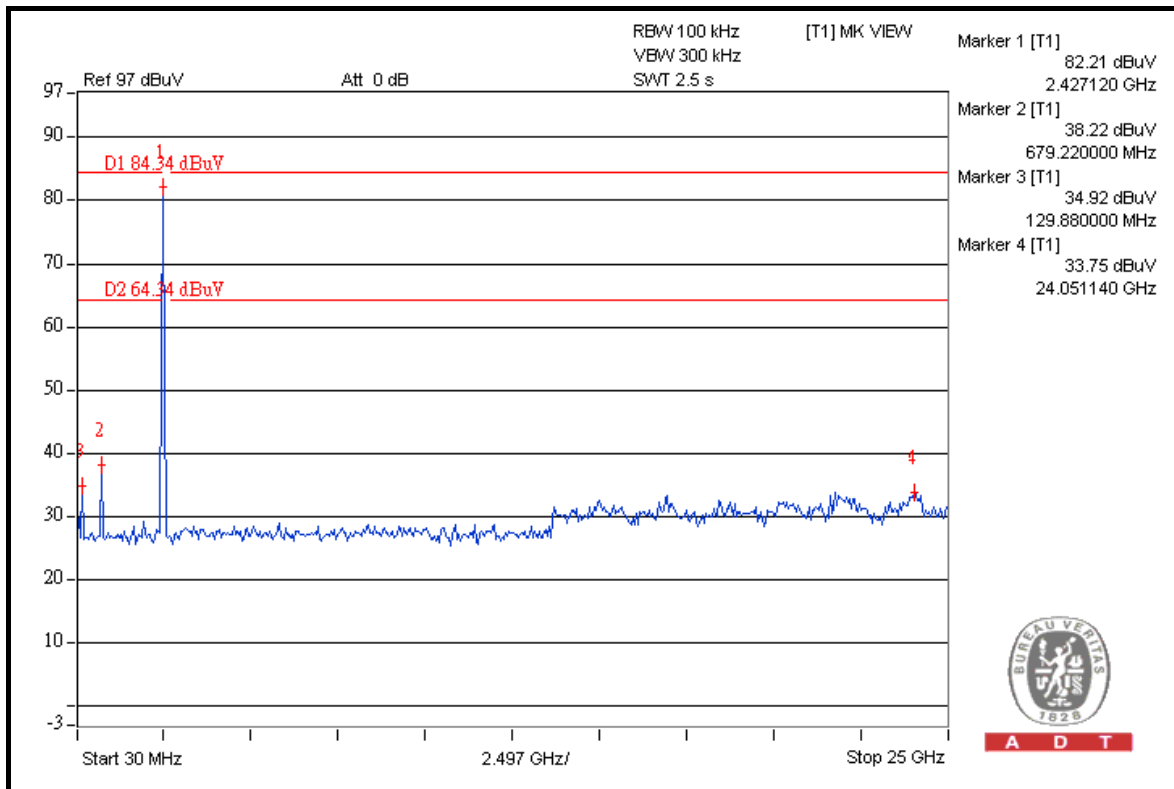
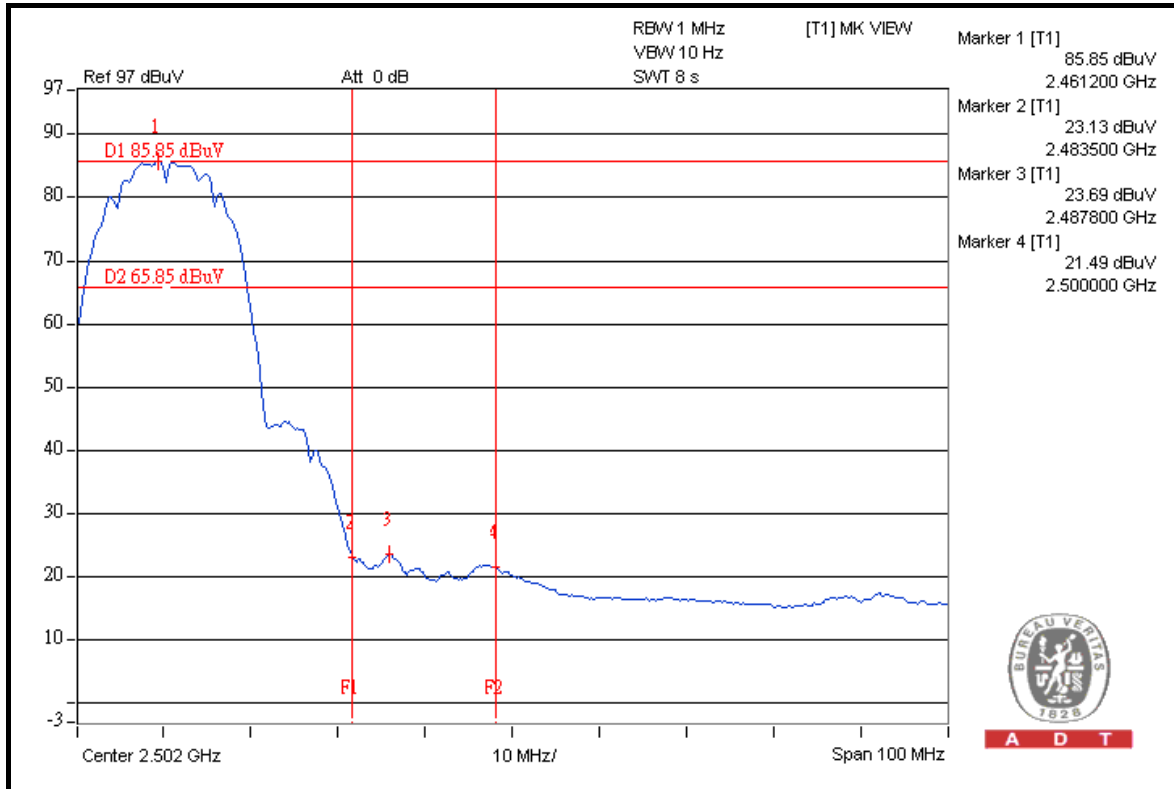



A D T

## 802.11g

### TEST MODE A

#### RESTRICT BAND (2310 ~ 2390 MHz)

FREQUENCY (MHz)	FUNDAMENTAL EMISSION (dBuV/m)	DELTA (dB)	MAXIMUM FIELD STRENGTH IN RESTRICT BAND (dBuV/m)	LIMIT (dBuV/m)
2412.00 (PK)	111.9	48.01	63.89	74.00
2412.00 (AV)	100.3	52.01	48.29	54.00

#### RESTRICT BAND (2483.5 ~ 2500 MHz)

FREQUENCY (MHz)	FUNDAMENTAL EMISSION (dBuV/m)	DELTA (dB)	MAXIMUM FIELD STRENGTH IN RESTRICT BAND (dBuV/m)	LIMIT (dBuV/m)
2462.00 (PK)	111.3	46.20	65.10	74.00
2462.00 (AV)	99.1	49.07	50.03	54.00

#### NOTE:

1. Delta = Amplitude between the peak of the fundamental and the peak of the band edge emission. Please check following 3 pages.
2. Maximum field strength in restrict band = Fundamental emission – Delta.



A D T

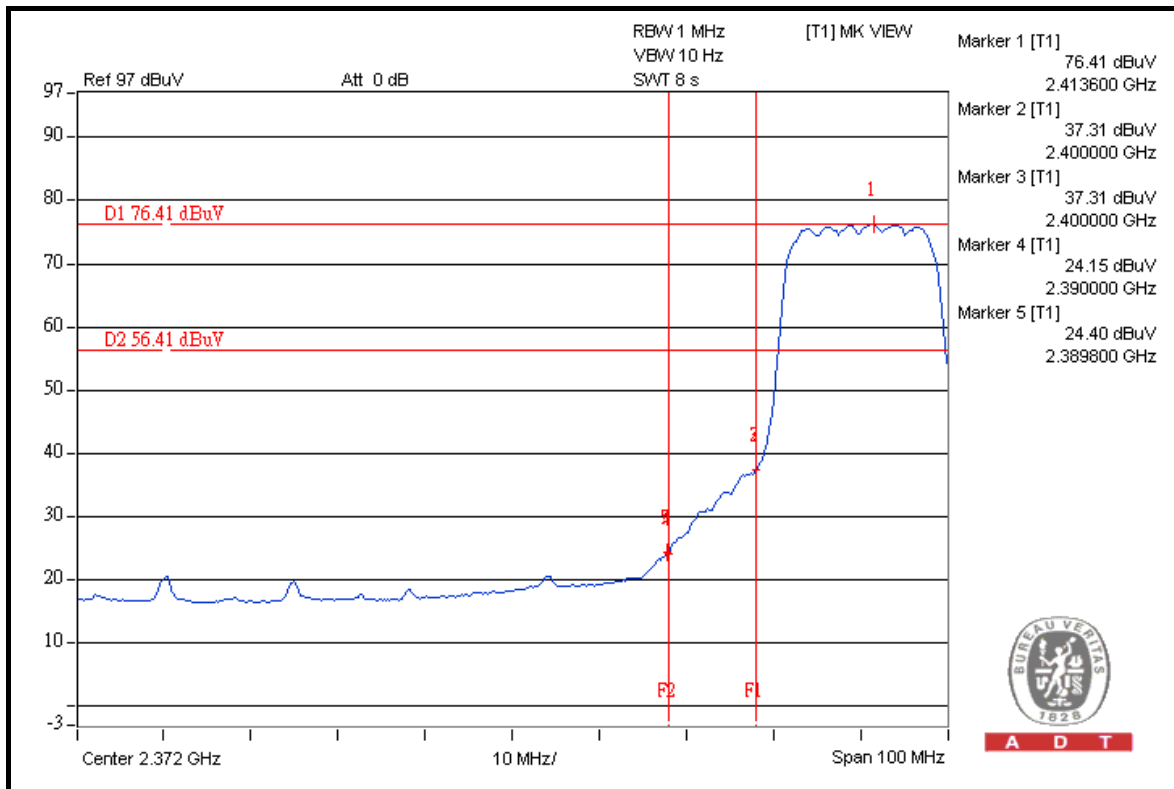
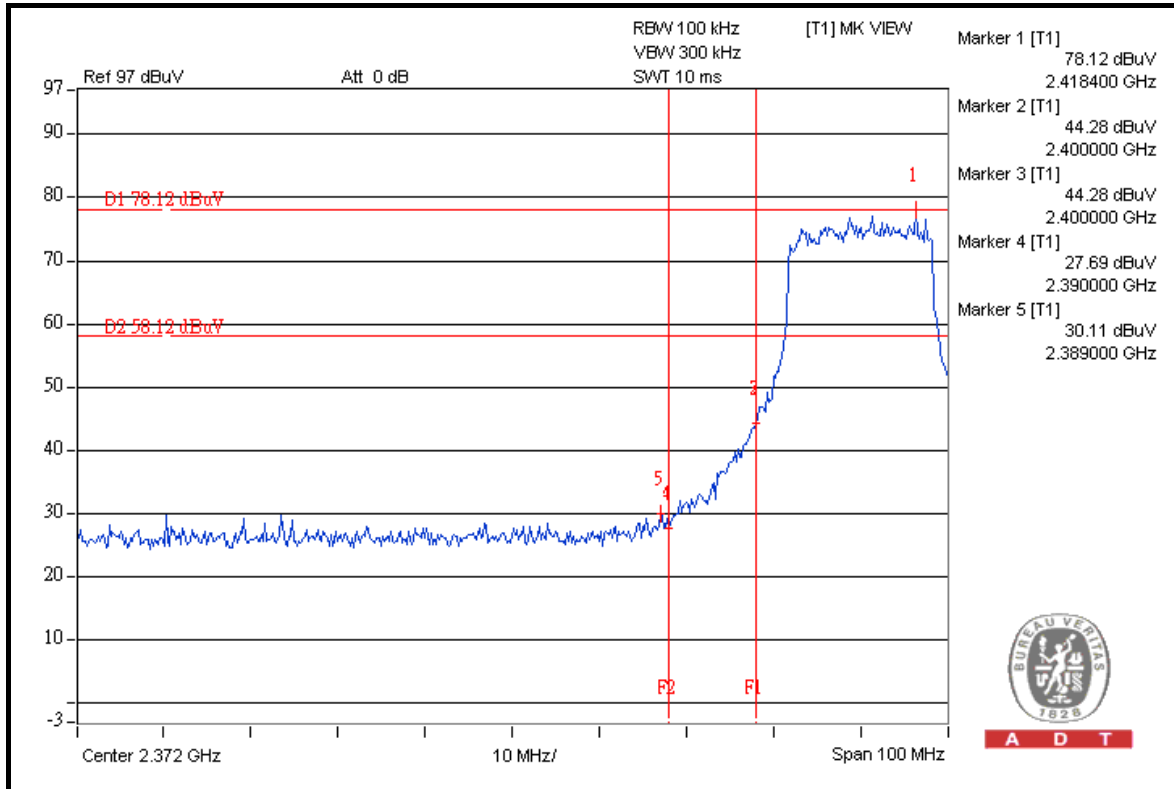



A D T

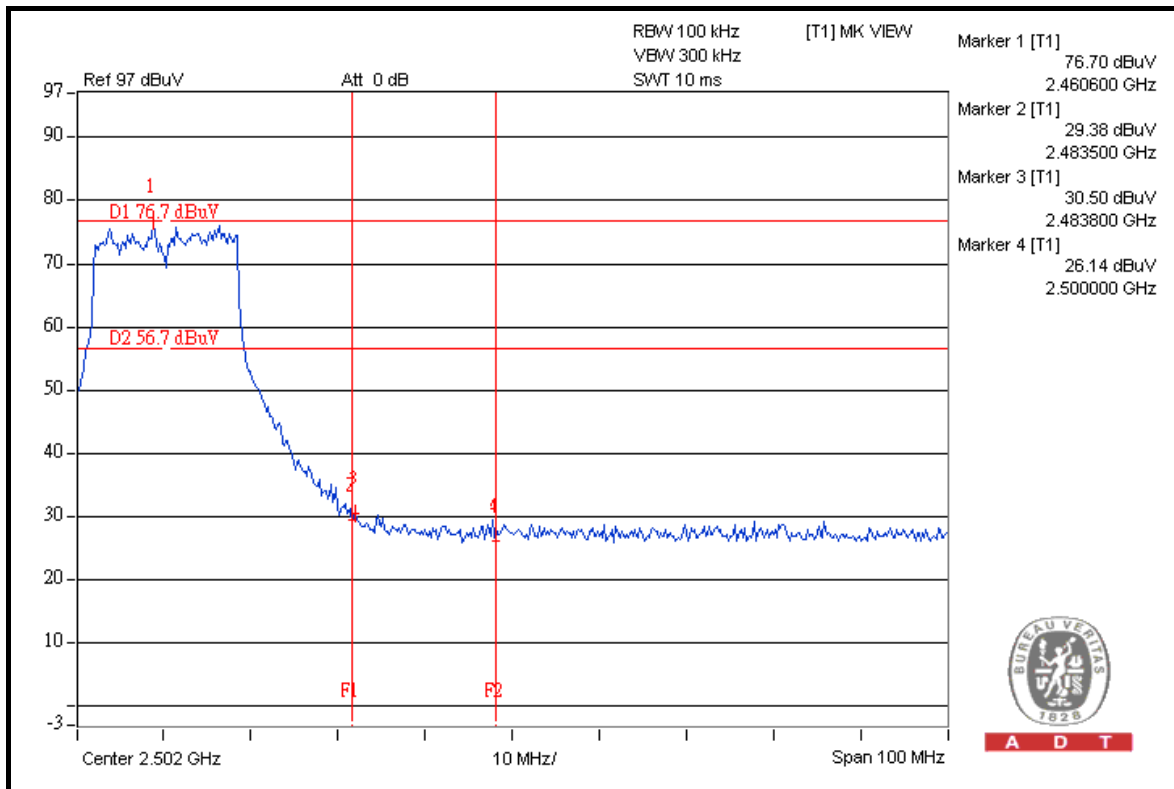
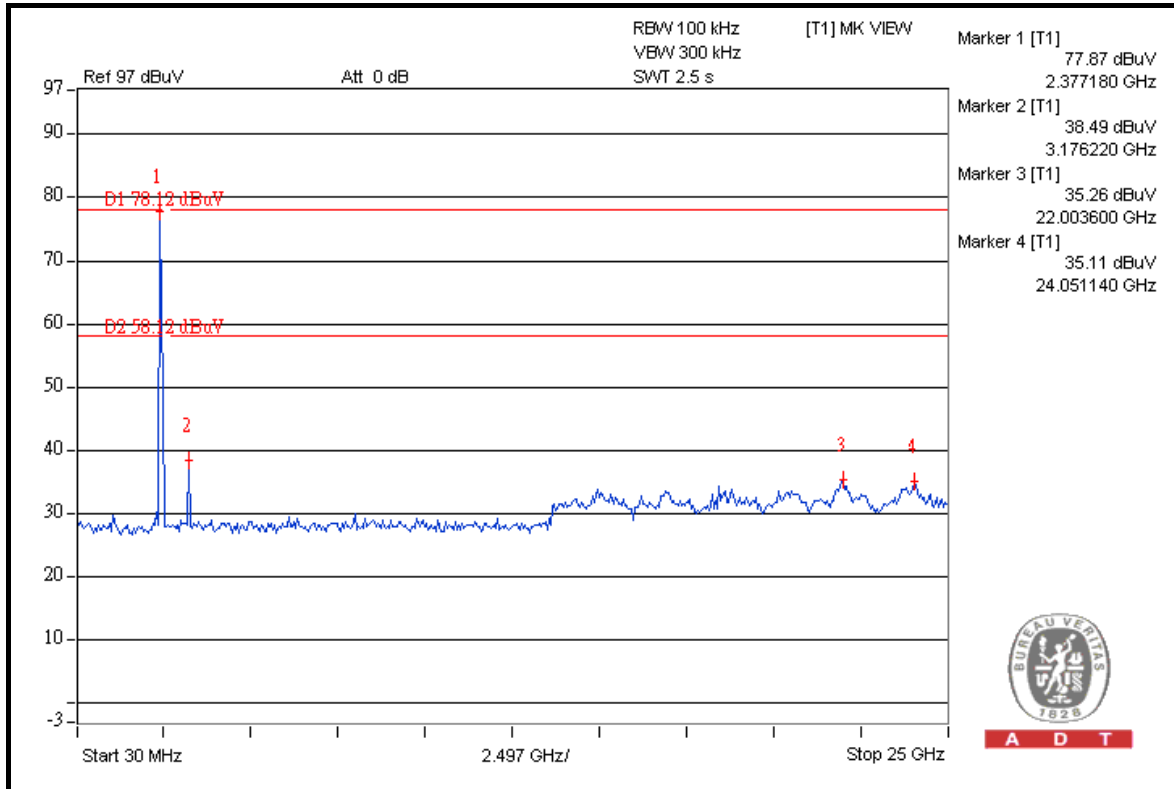



A D T

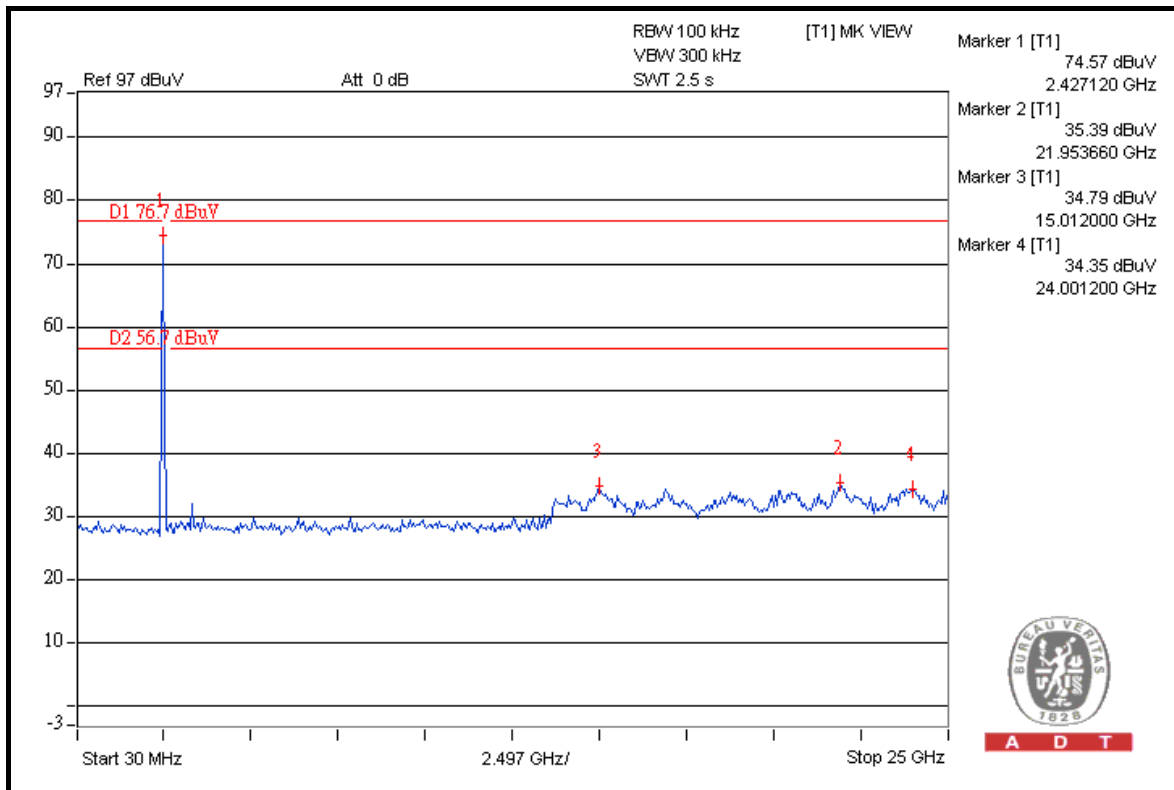
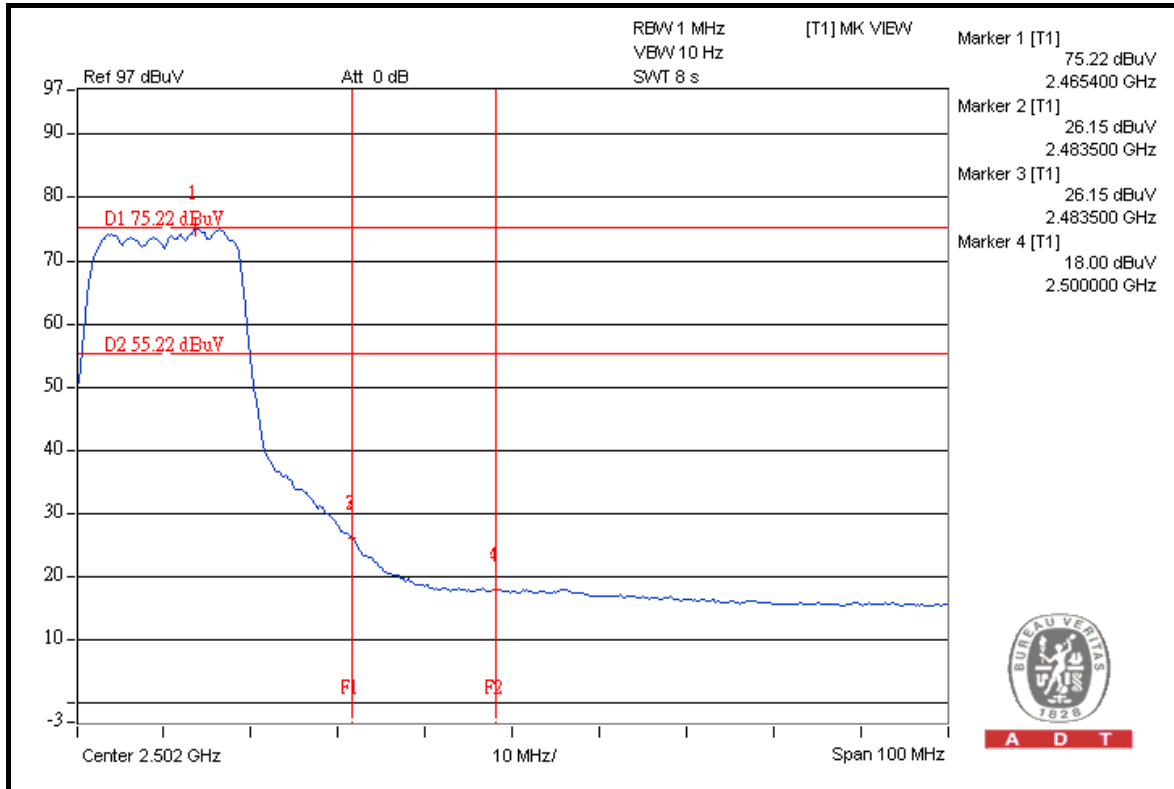





A D T

### TEST MODE C

#### RESTRICT BAND (2310 ~ 2390 MHz)

FREQUENCY (MHz)	FUNDAMENTAL EMISSION (dBuV/m)	DELTA (dB)	MAXIMUM FIELD STRENGTH IN RESTRICT BAND (dBuV/m)	LIMIT (dBuV/m)
2412.00 (PK)	112.0	48.71	63.29	74.00
2412.00 (AV)	101.8	53.87	47.93	54.00

#### RESTRICT BAND (2483.5 ~ 2500 MHz)

FREQUENCY (MHz)	FUNDAMENTAL EMISSION (dBuV/m)	DELTA (dB)	MAXIMUM FIELD STRENGTH IN RESTRICT BAND (dBuV/m)	LIMIT (dBuV/m)
2462.00 (PK)	112.7	50.33	62.37	74.00
2462.00 (AV)	102.6	53.02	49.58	54.00

#### NOTE:

1. Delta = Amplitude between the peak of the fundamental and the peak of the band edge emission. Please check following 3 pages.
2. Maximum field strength in restrict band = Fundamental emission – Delta.



A D T

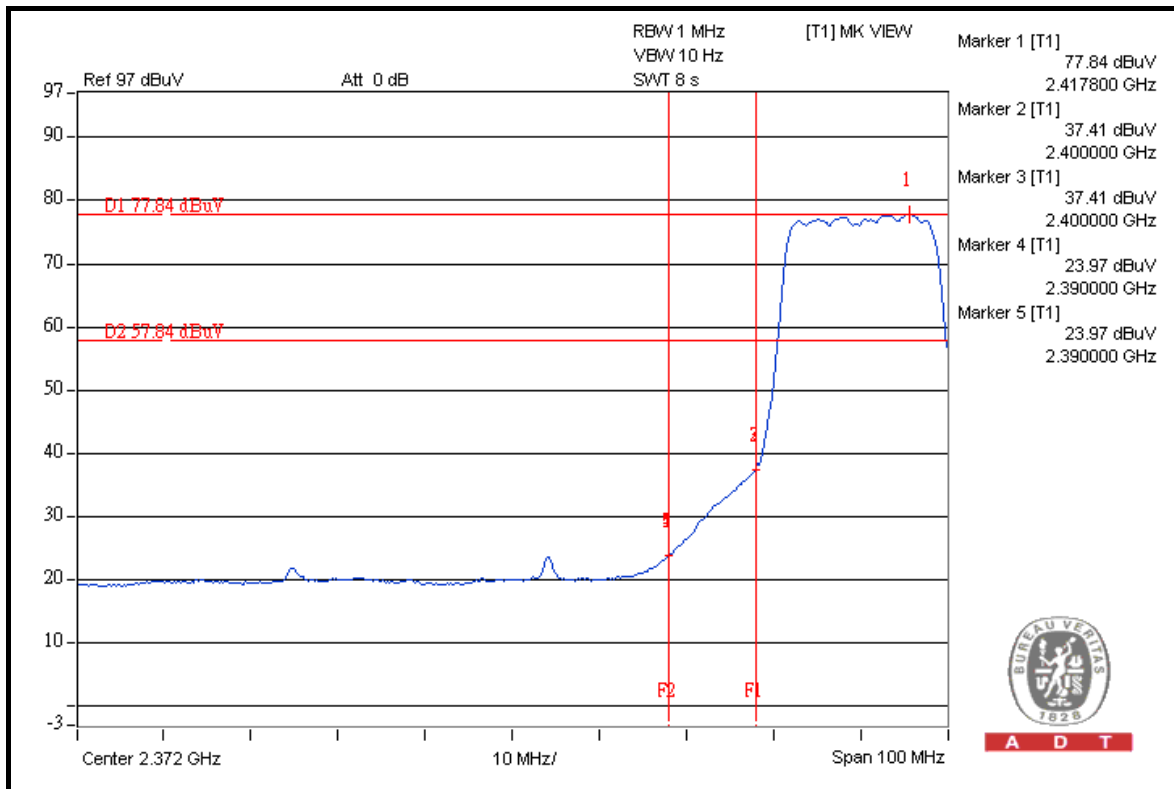
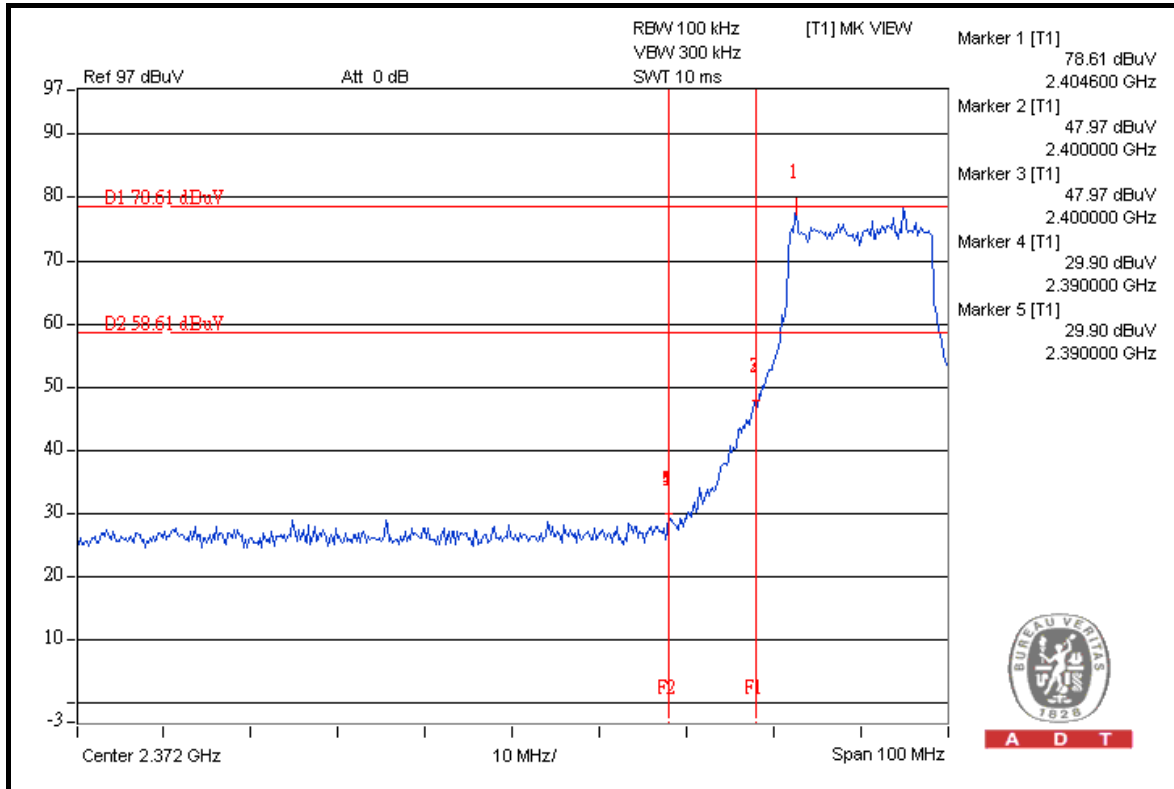



A D T

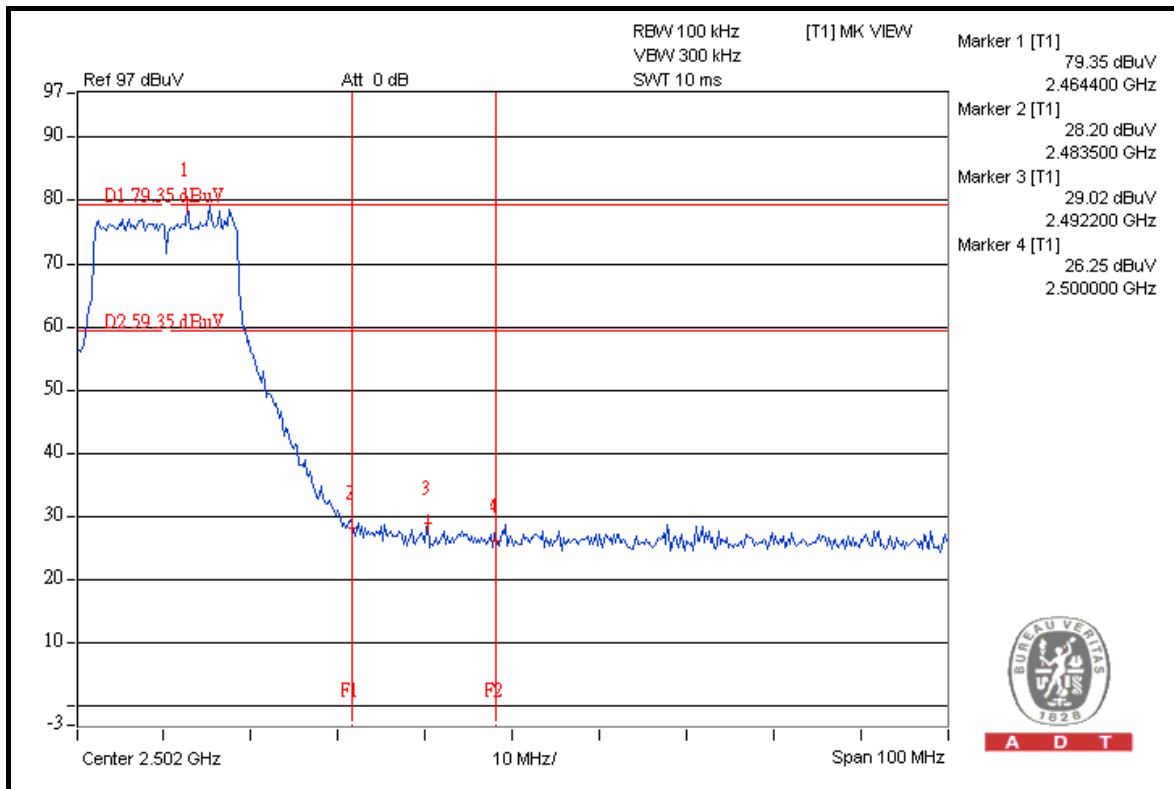
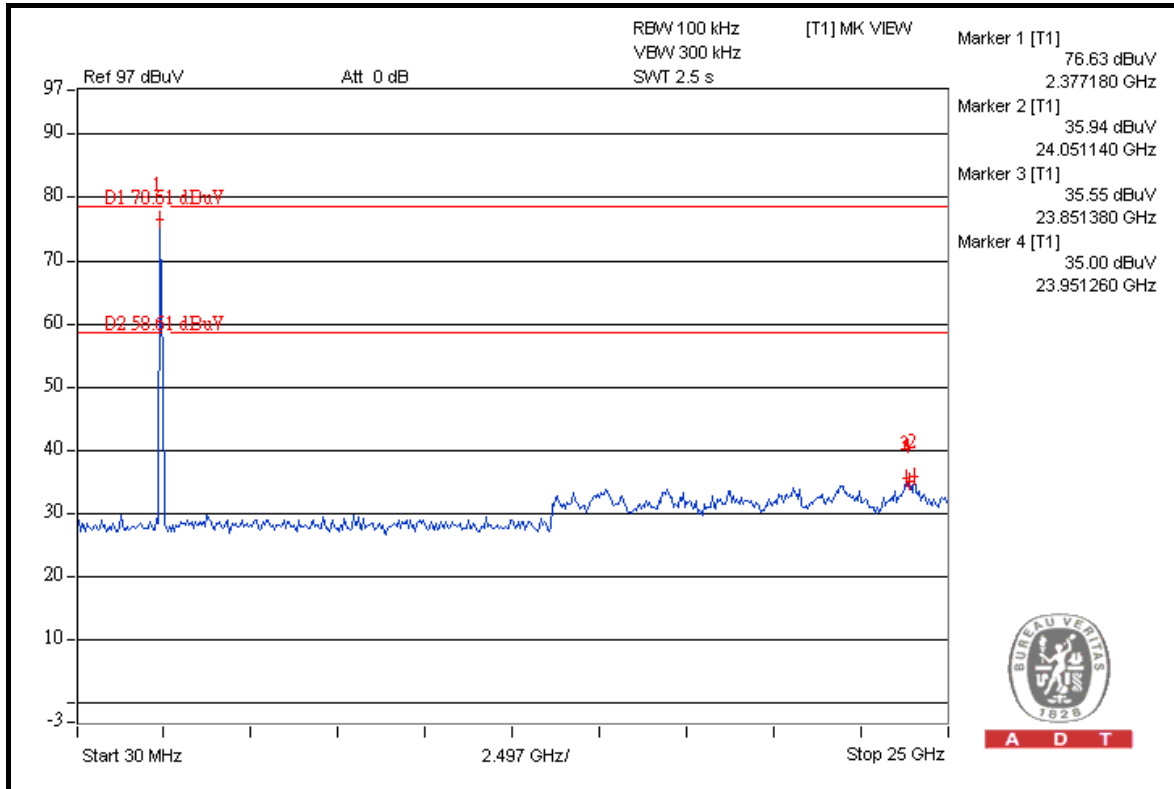



A D T

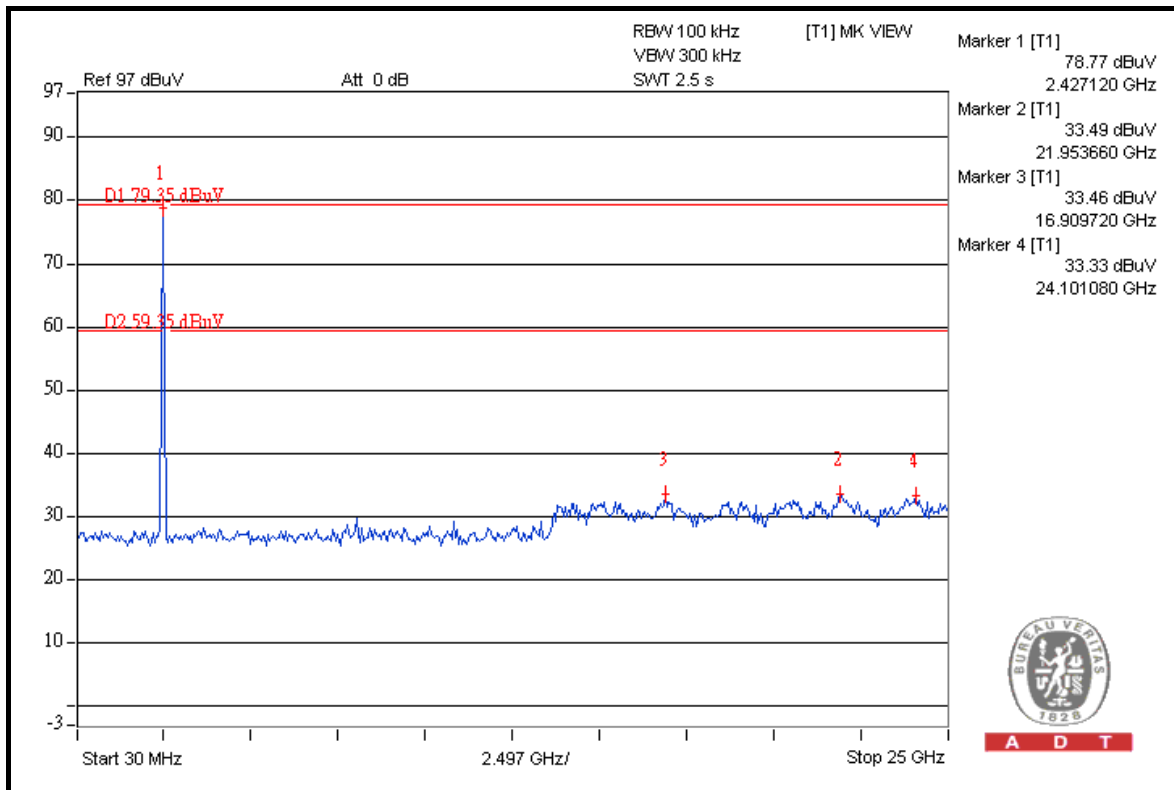
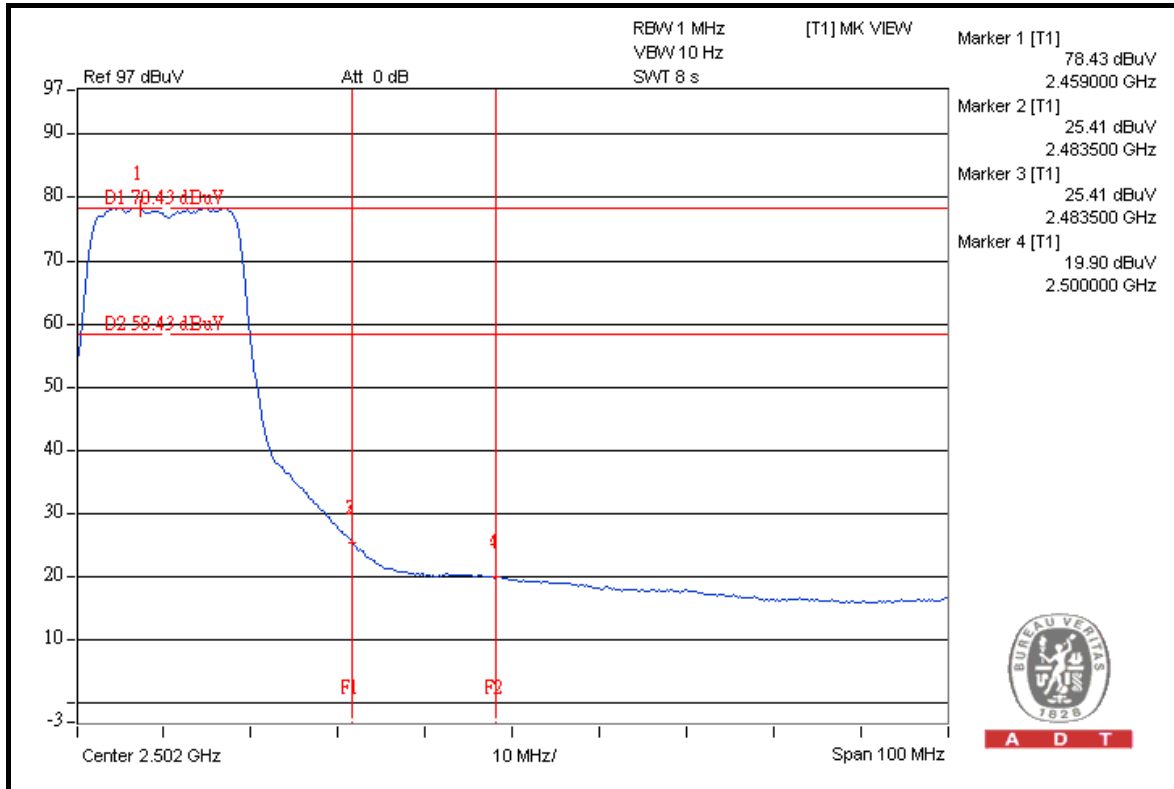



A D T

## 802.11n (20MHz)

### TEST MDOE A

#### RESTRICT BAND (2310 ~ 2390 MHz)

FREQUENCY (MHz)	FUNDAMENTAL EMISSION (dBuV/m)	DELTA (dB)	MAXIMUM FIELD STRENGTH IN RESTRICT BAND (dBuV/m)	LIMIT (dBuV/m)
2412.00 (PK)	111.5	44.96	66.54	74.00
2412.00 (AV)	99.7	48.98	50.72	54.00

#### RESTRICT BAND (2483.5 ~ 2500 MHz)

FREQUENCY (MHz)	FUNDAMENTAL EMISSION (dBuV/m)	DELTA (dB)	MAXIMUM FIELD STRENGTH IN RESTRICT BAND (dBuV/m)	LIMIT (dBuV/m)
2462.00 (PK)	109.6	46.13	63.47	74.00
2462.00 (AV)	98.3	49.50	48.80	54.00

#### NOTE:

1. Delta = Amplitude between the peak of the fundamental and the peak of the band edge emission. Please check following 3 pages.
2. Maximum field strength in restrict band = Fundamental emission – Delta.



A D T

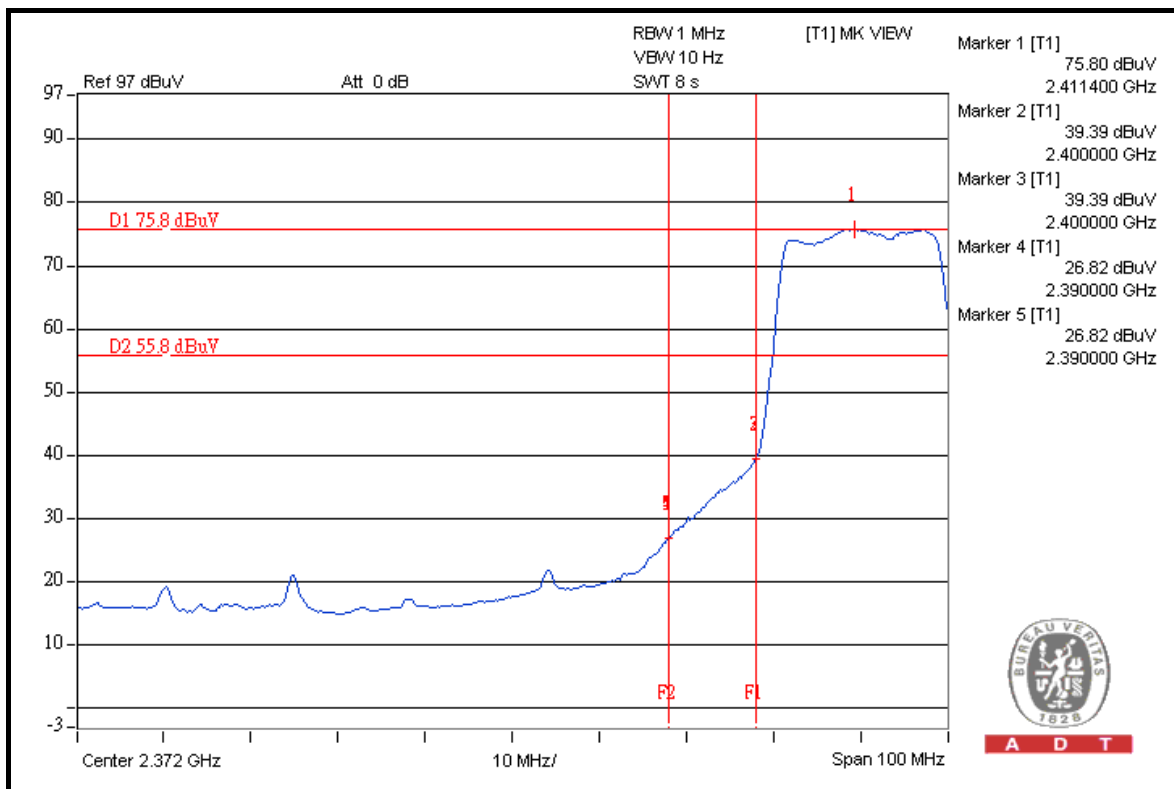
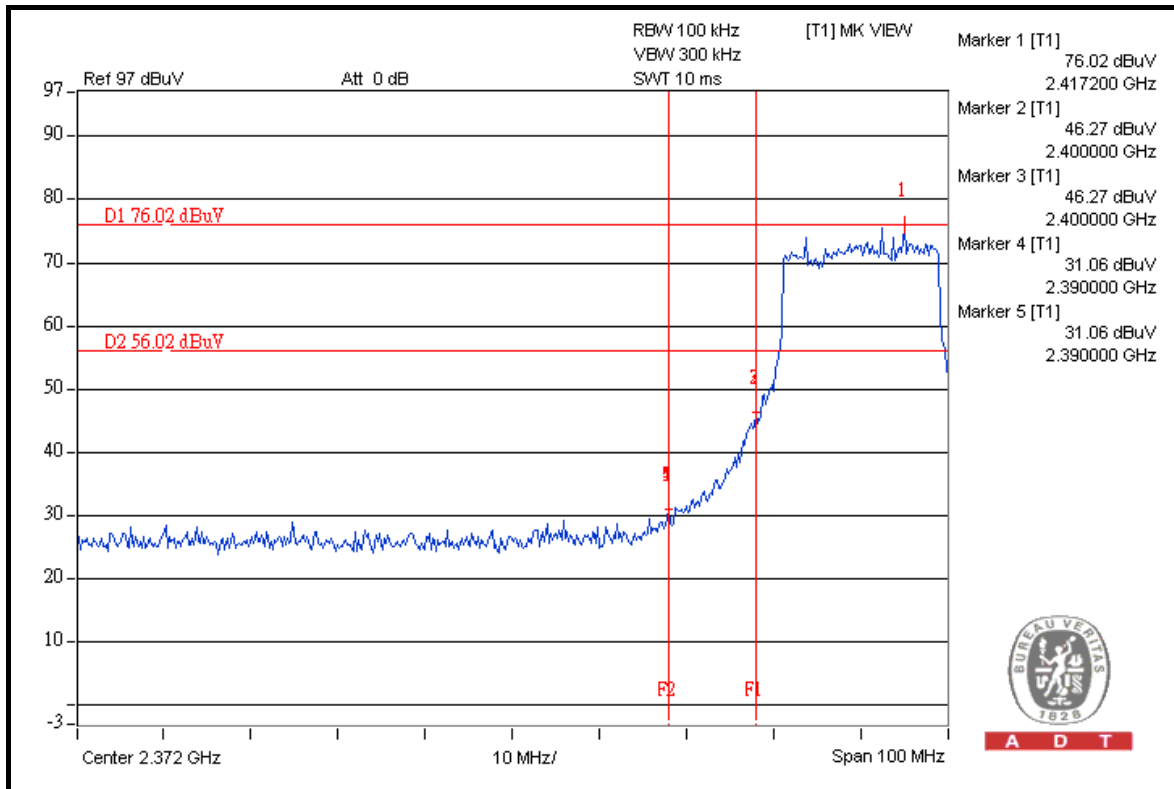



A D T

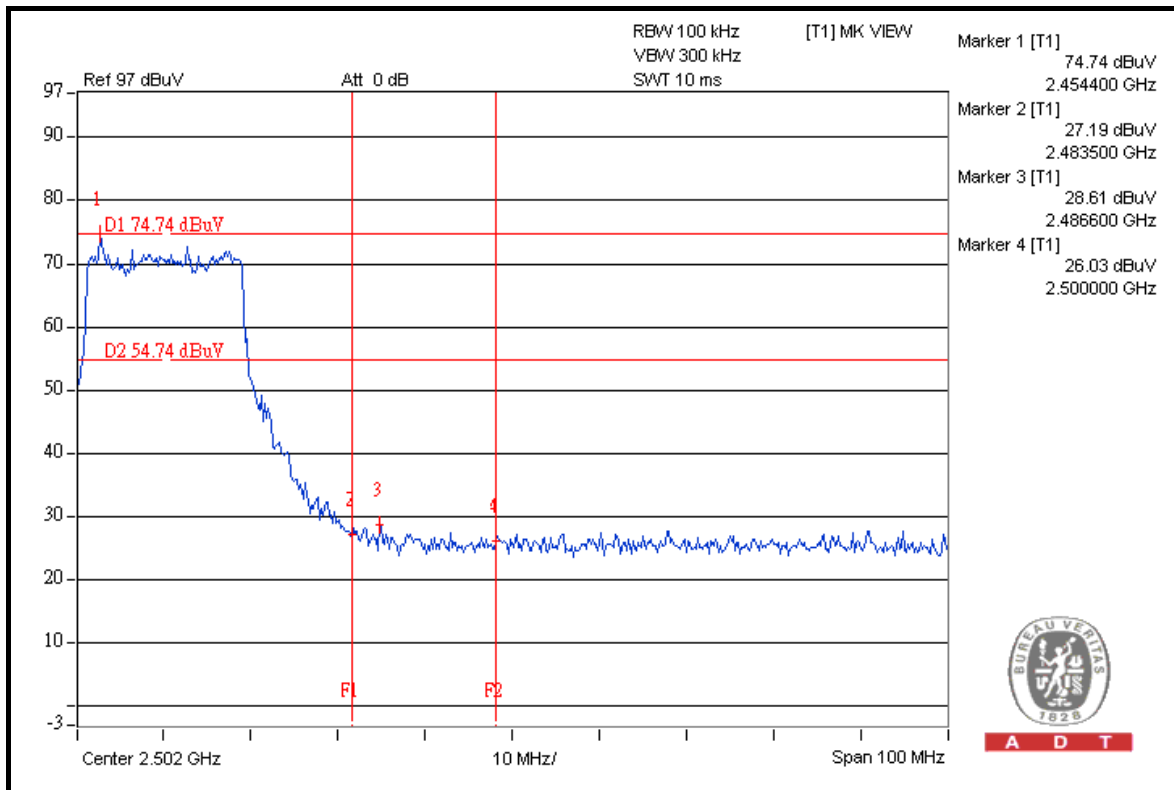
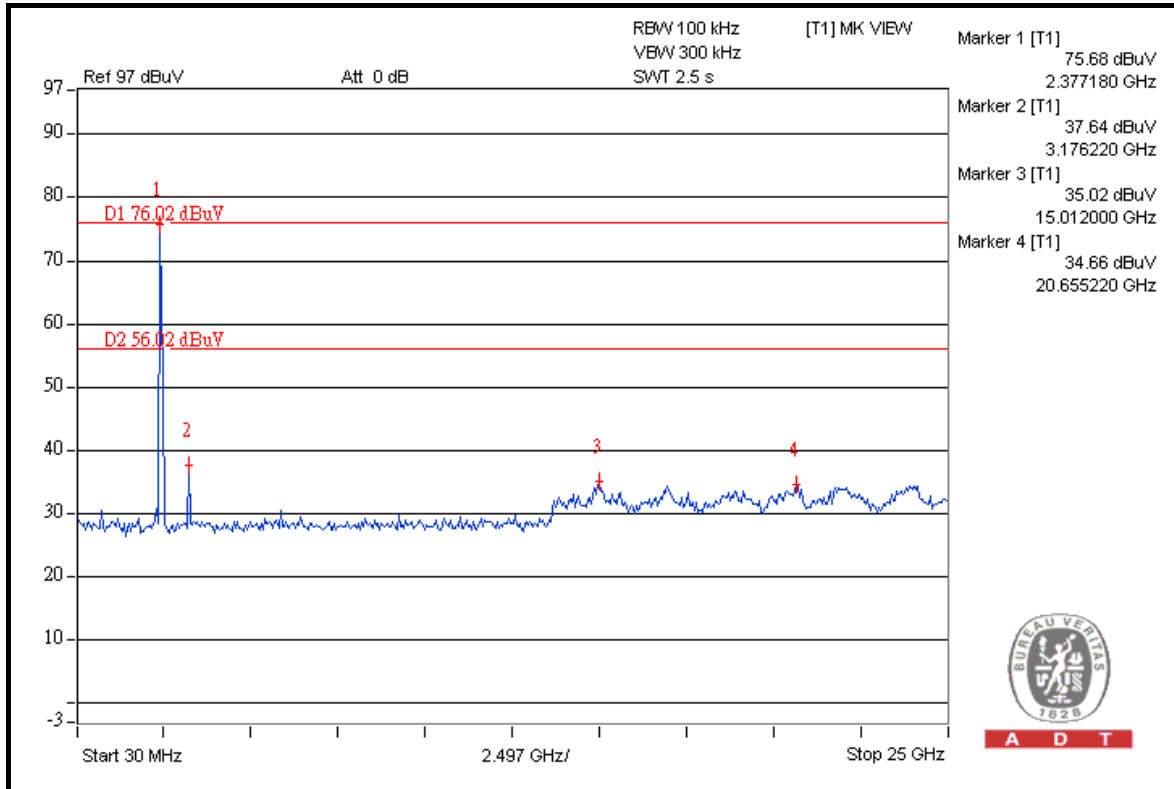



A D T

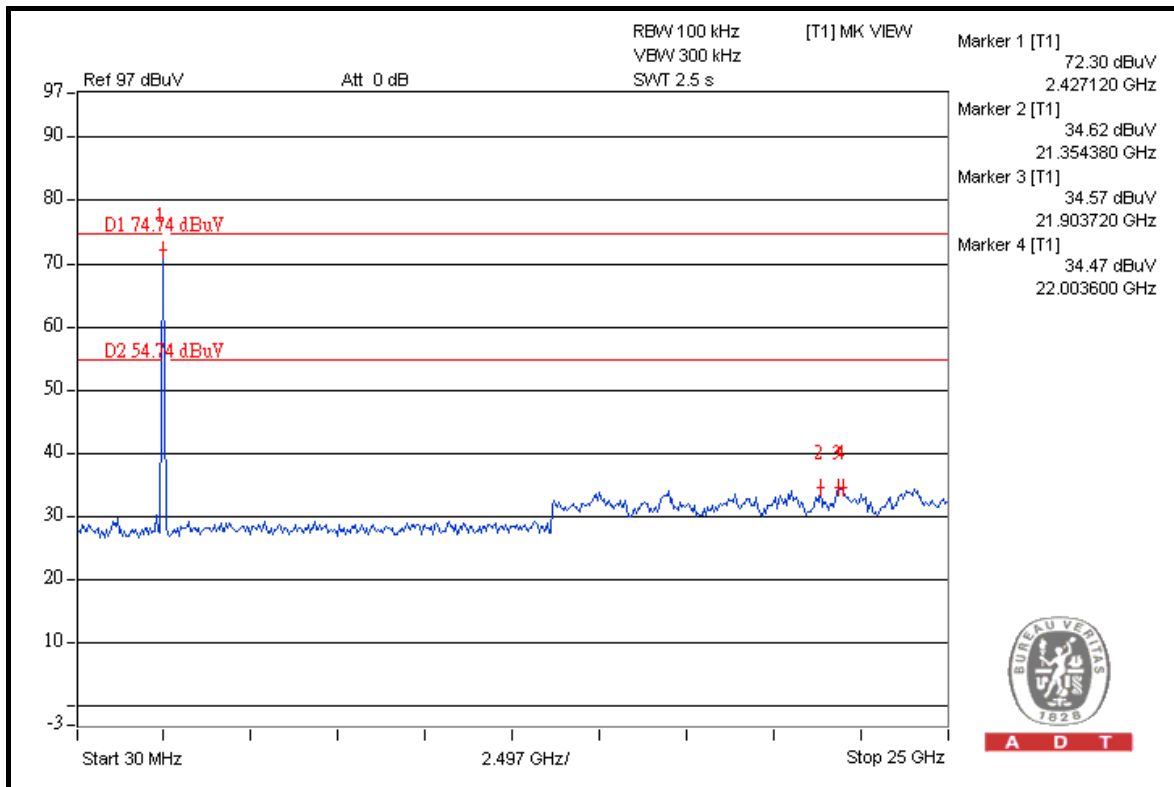
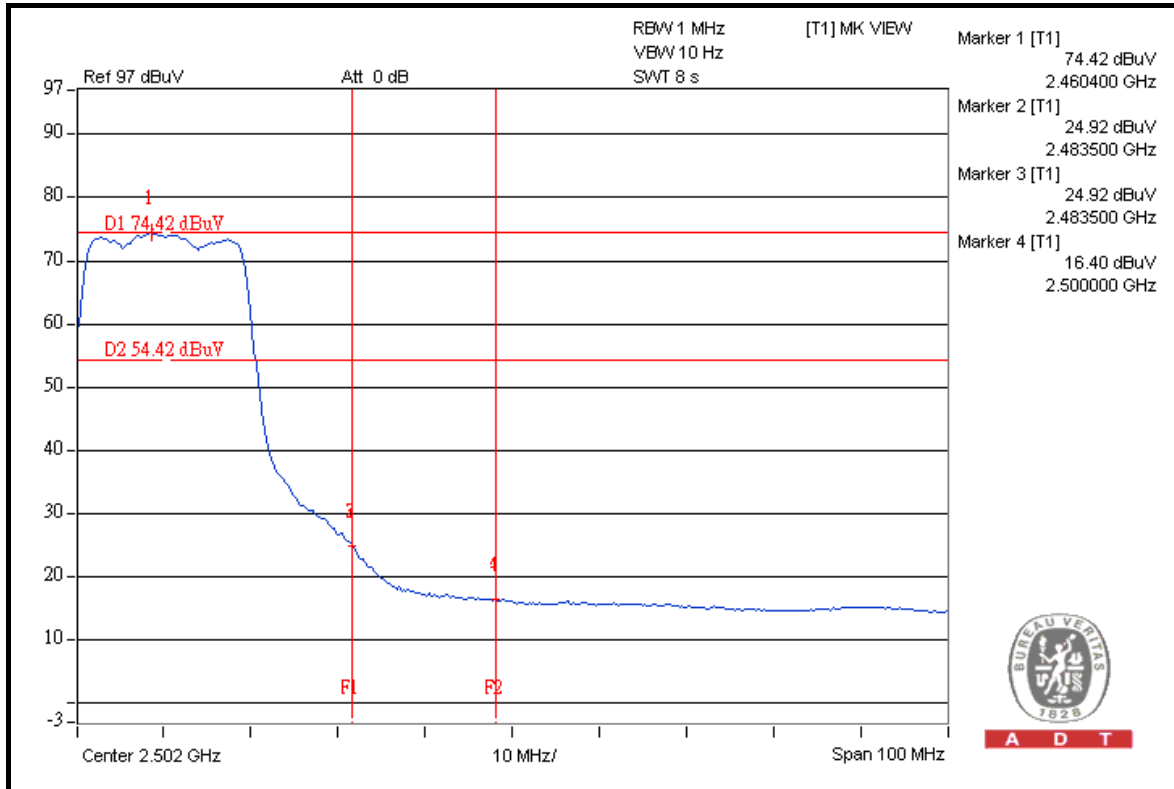





A D T

## TEST MDOE C

### RESTRICT BAND (2310 ~ 2390 MHz)

FREQUENCY (MHz)	FUNDAMENTAL EMISSION (dBuV/m)	DELTA (dB)	MAXIMUM FIELD STRENGTH IN RESTRICT BAND (dBuV/m)	LIMIT (dBuV/m)
2412.00 (PK)	111.2	46.89	64.31	74.00
2412.00 (AV)	100.2	53.14	47.06	54.00

### RESTRICT BAND (2483.5 ~ 2500 MHz)

FREQUENCY (MHz)	FUNDAMENTAL EMISSION (dBuV/m)	DELTA (dB)	MAXIMUM FIELD STRENGTH IN RESTRICT BAND (dBuV/m)	LIMIT (dBuV/m)
2462.00 (PK)	111.8	46.31	65.49	74.00
2462.00 (AV)	100.8	52.50	48.30	54.00

#### NOTE:

1. Delta = Amplitude between the peak of the fundamental and the peak of the band edge emission. Please check following 3 pages.
2. Maximum field strength in restrict band = Fundamental emission – Delta.



A D T

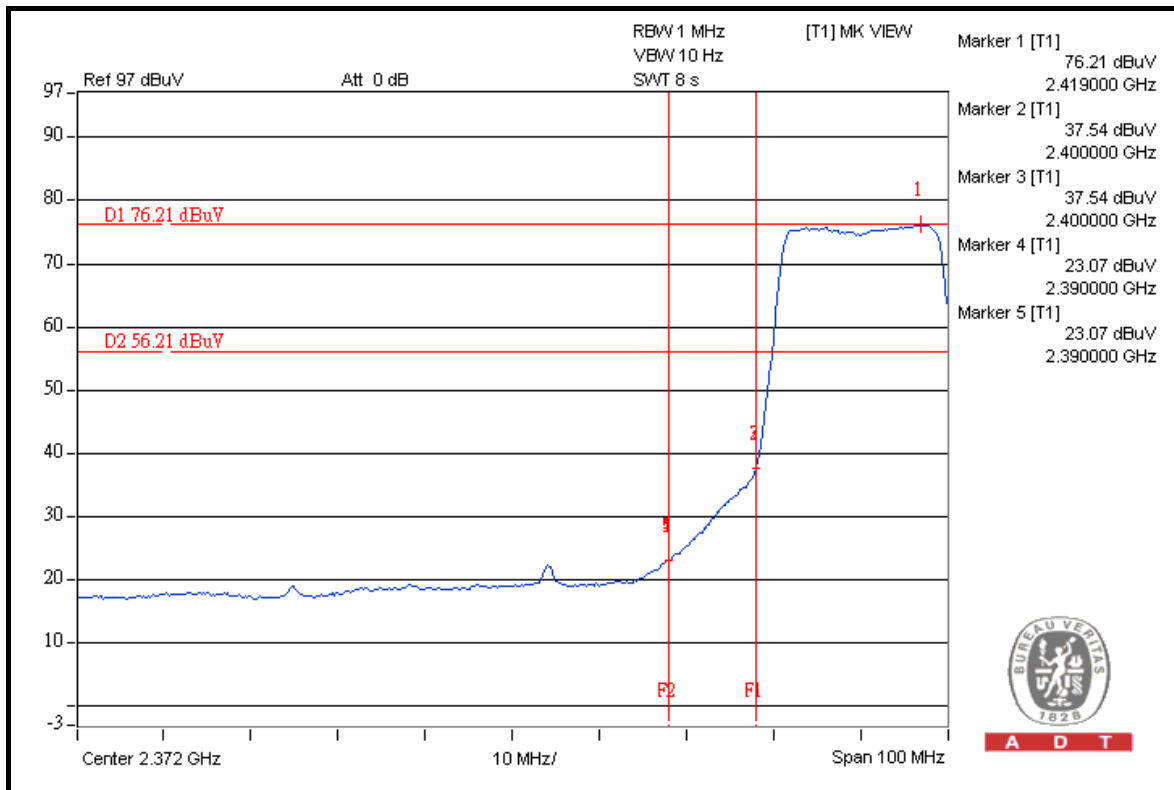
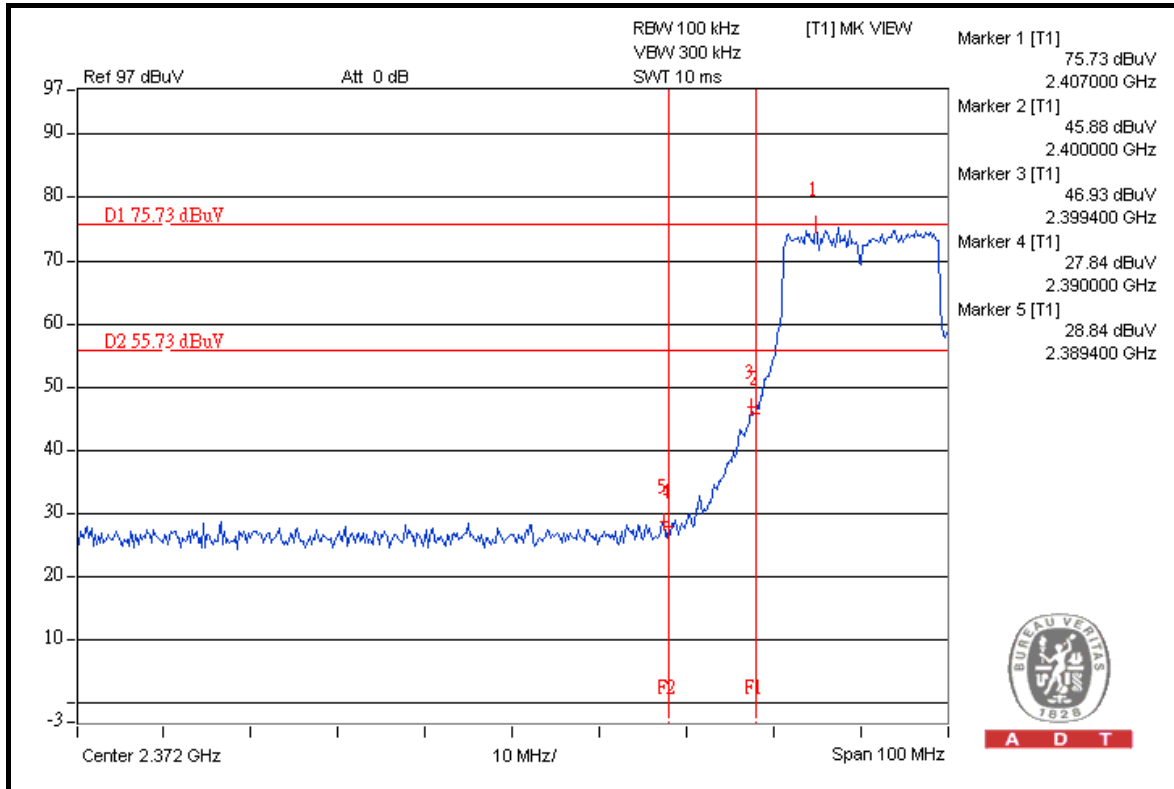



A D T

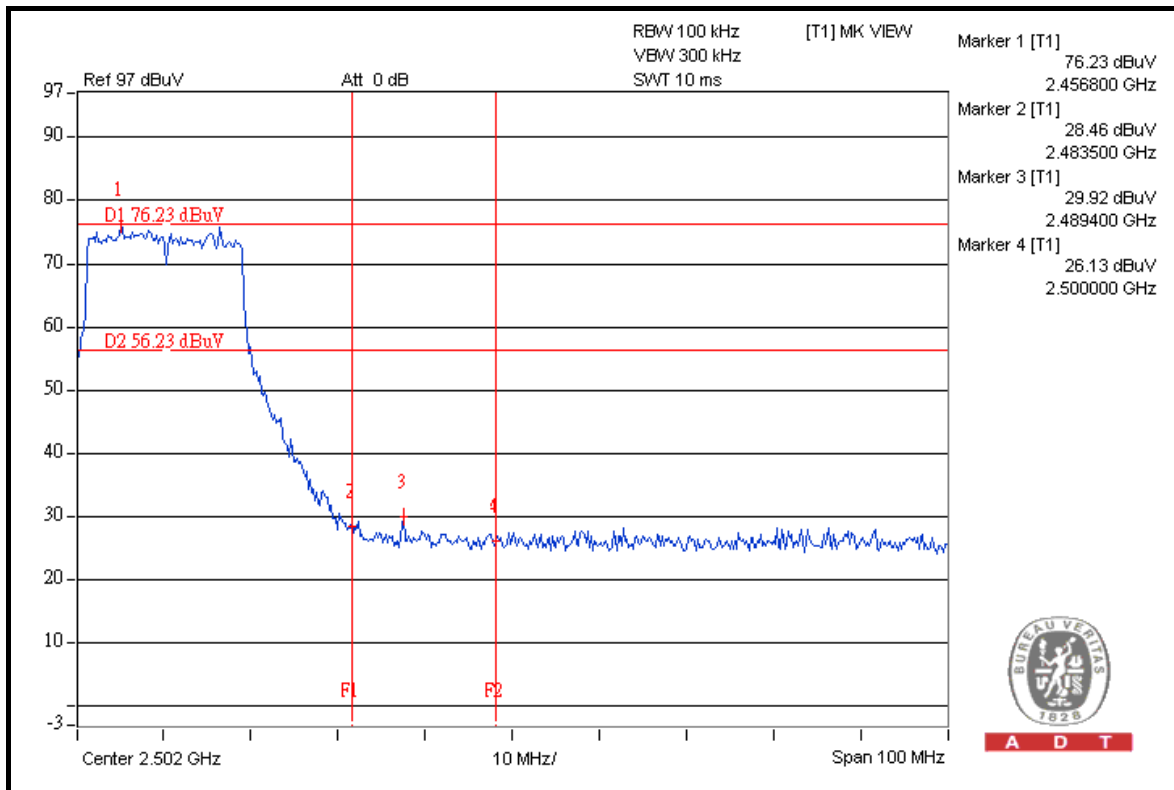
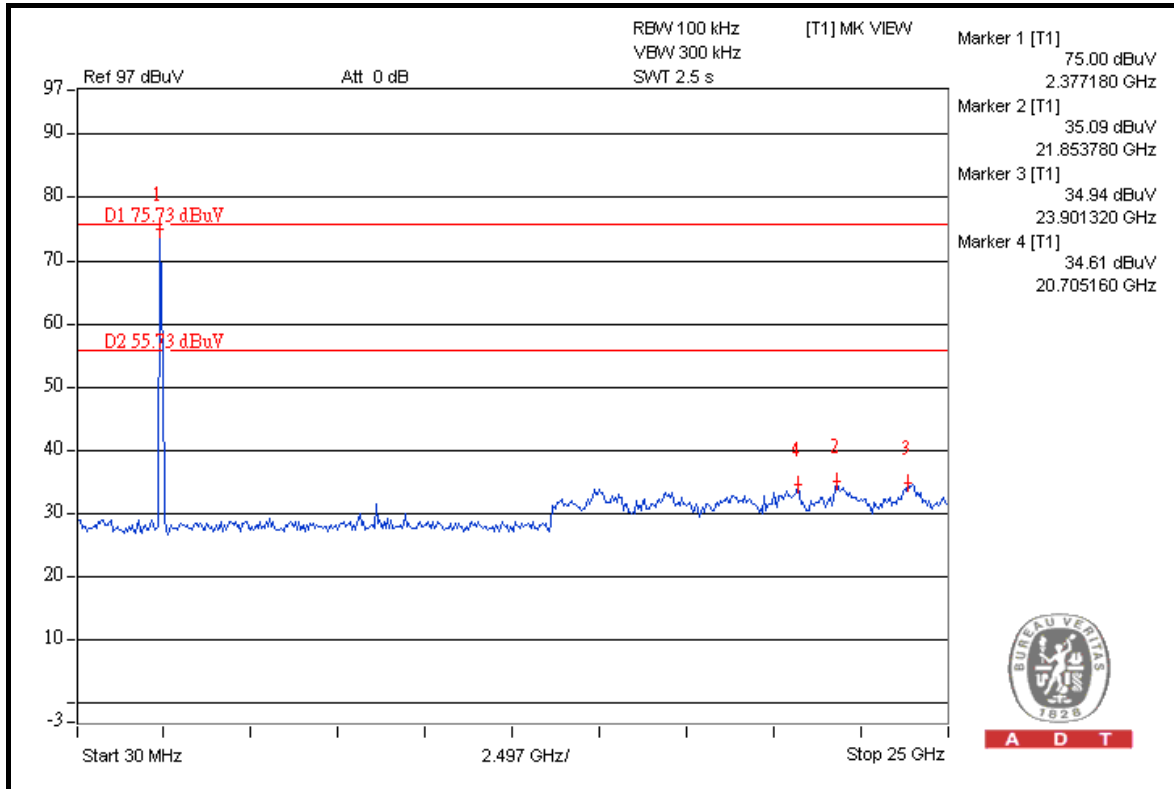



A D T

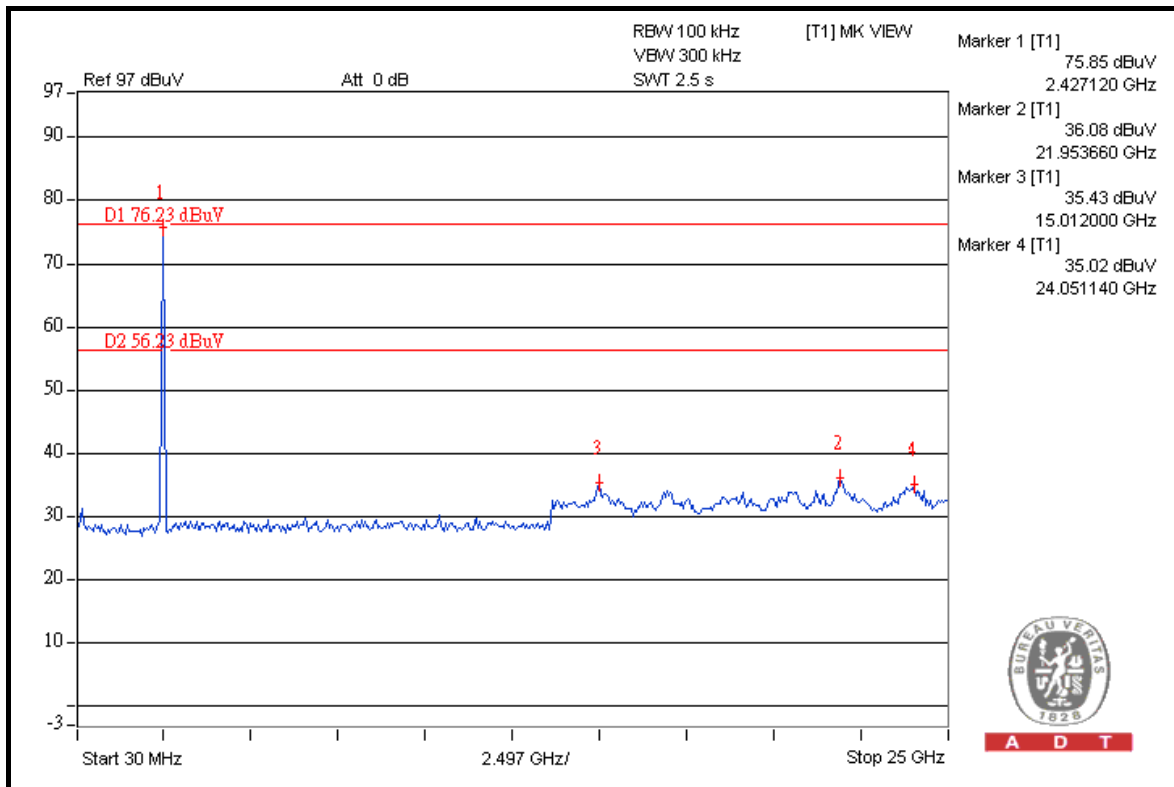
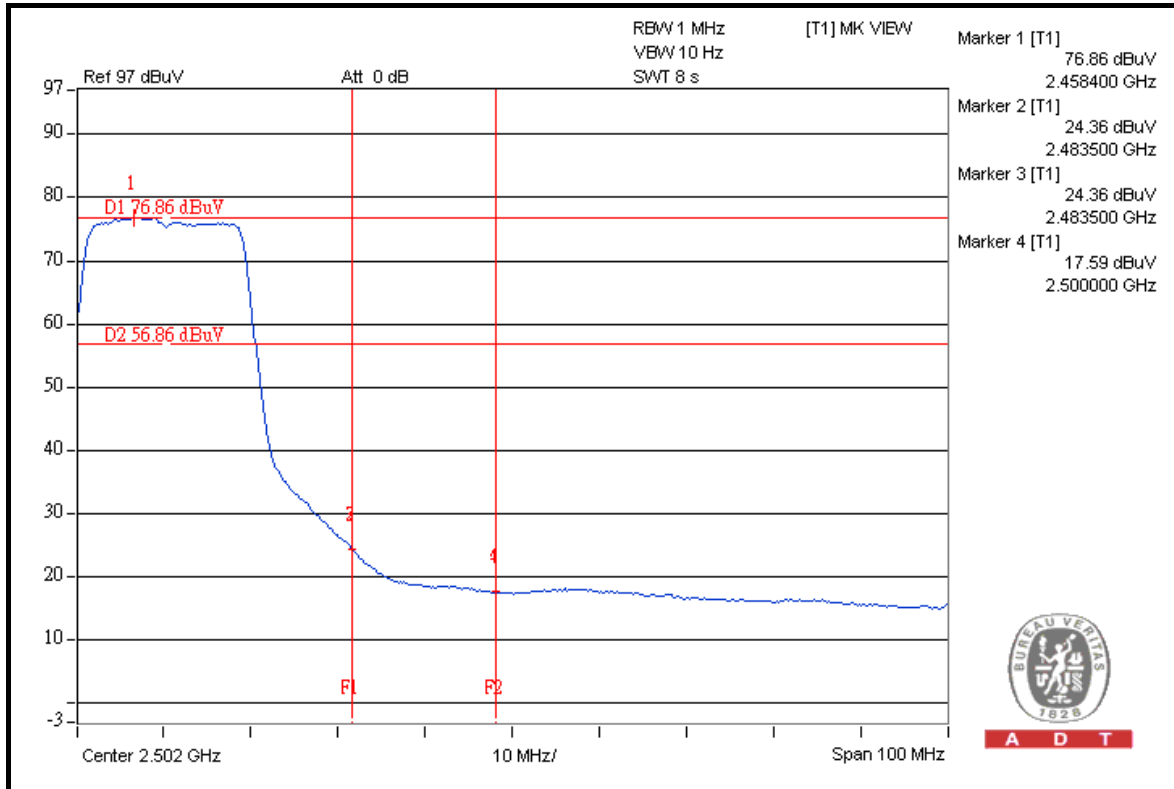



A D T

## 802.11n (40MHz)

### TEST MDOE A

#### RESTRICT BAND (2310 ~ 2390 MHz)

FREQUENCY (MHz)	FUNDAMENTAL EMISSION (dBuV/m)	DELTA (dB)	MAXIMUM FIELD STRENGTH IN RESTRICT BAND (dBuV/m)	LIMIT (dBuV/m)
2422.00 (PK)	103.2	38.51	64.69	74.00
2422.00 (AV)	93.4	43.00	50.40	54.00

#### RESTRICT BAND (2483.5 ~ 2500 MHz)

FREQUENCY (MHz)	FUNDAMENTAL EMISSION (dBuV/m)	DELTA (dB)	MAXIMUM FIELD STRENGTH IN RESTRICT BAND (dBuV/m)	LIMIT (dBuV/m)
2452.00 (PK)	101.0	35.63	65.37	74.00
2452.00 (AV)	90.6	41.13	49.47	54.00

#### NOTE:

1. Delta = Amplitude between the peak of the fundamental and the peak of the band edge emission. Please check following 3 pages.
2. Maximum field strength in restrict band = Fundamental emission – Delta.



A D T

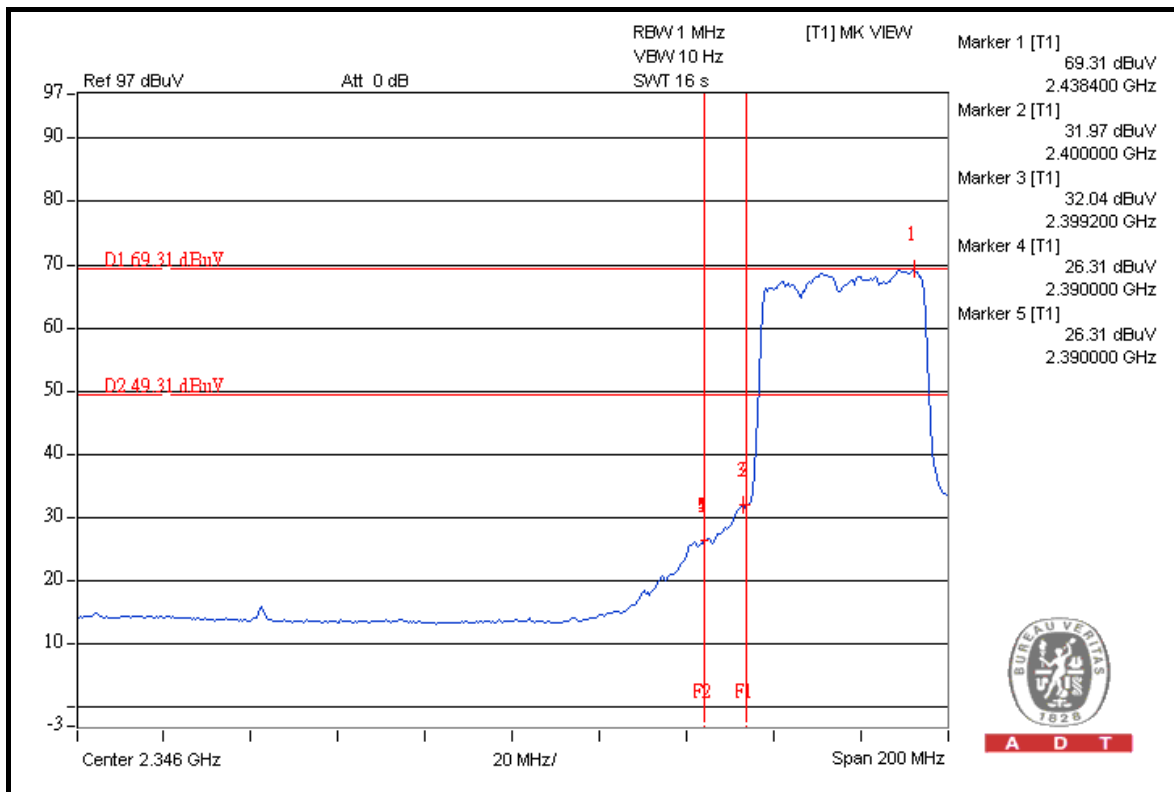
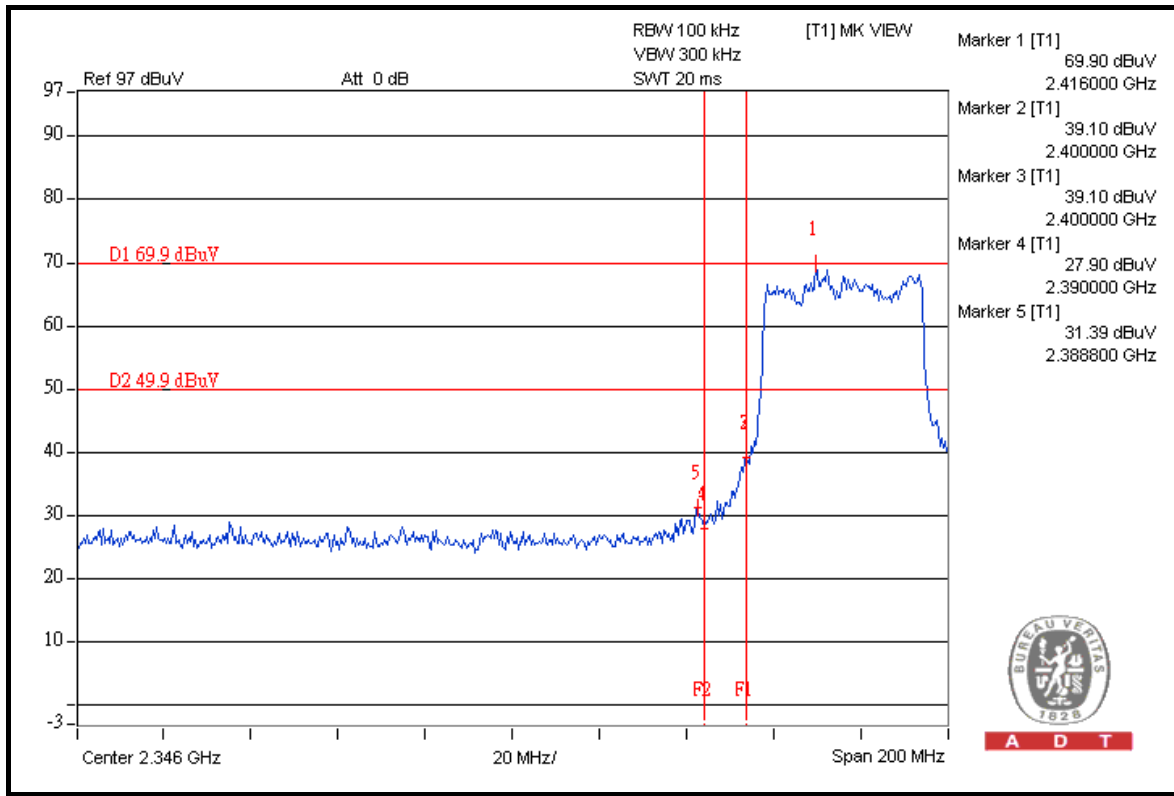



A D T

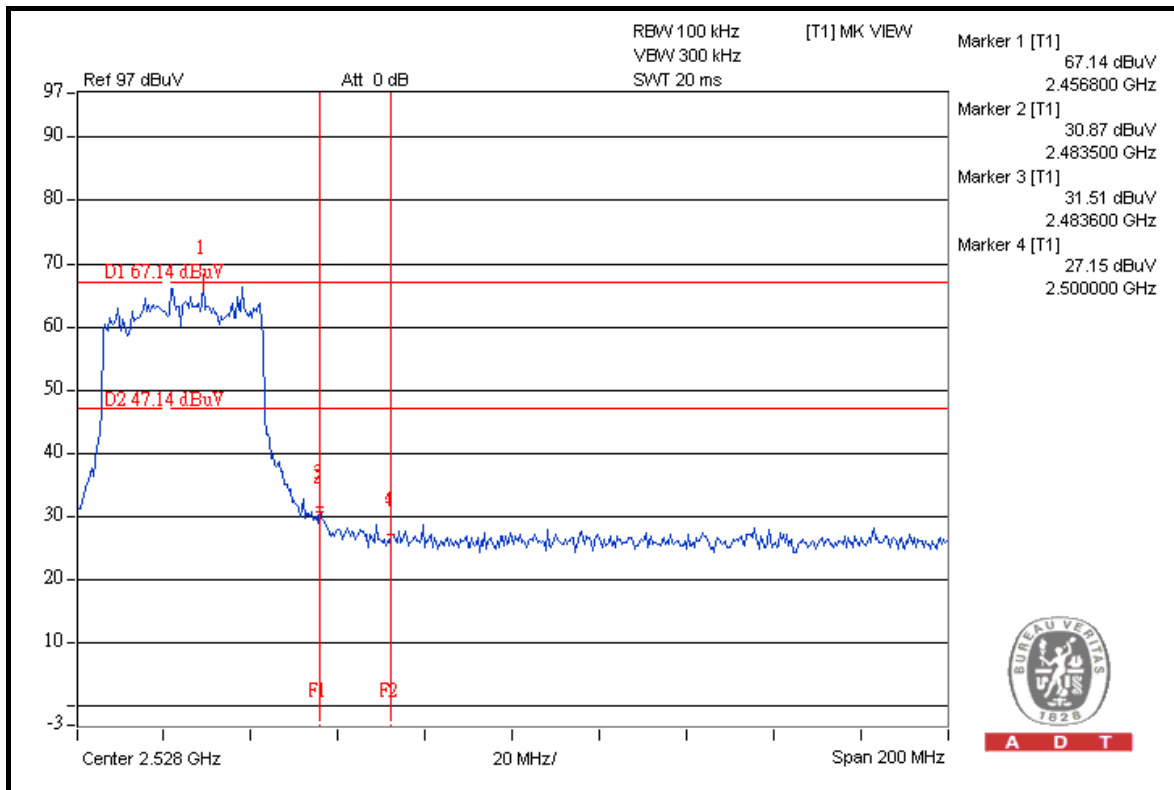
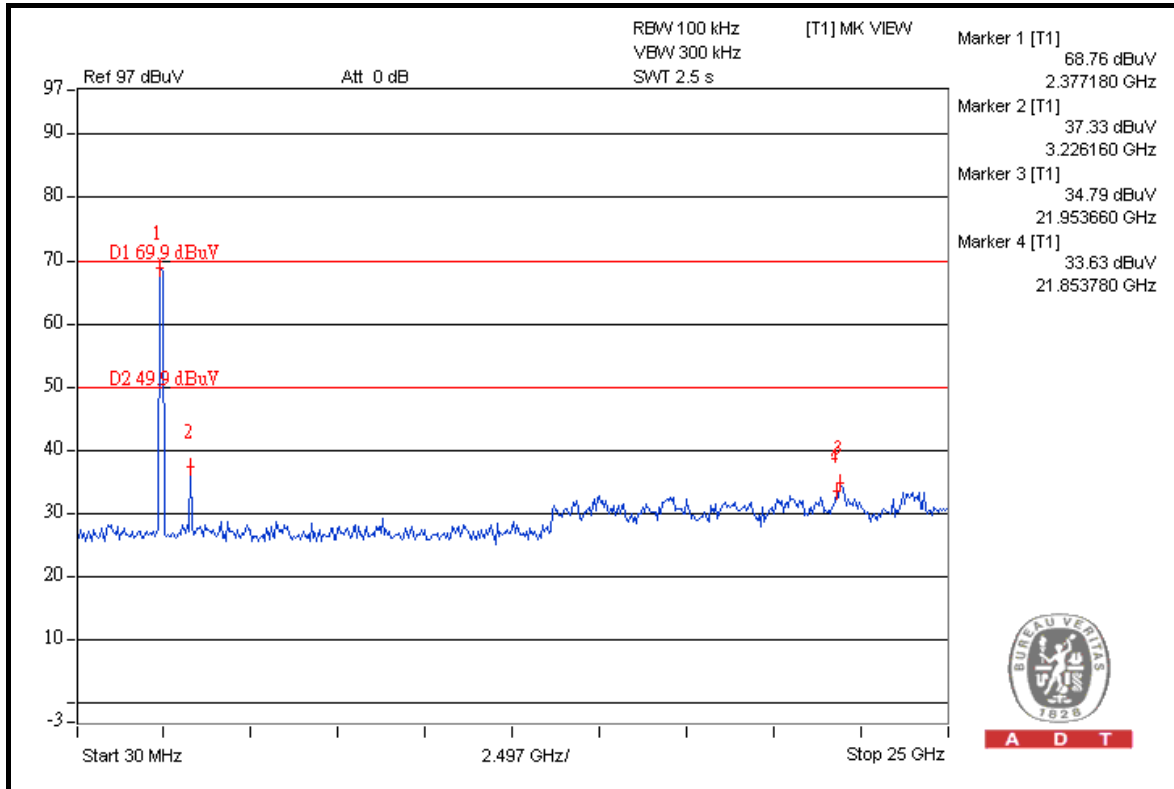



A D T

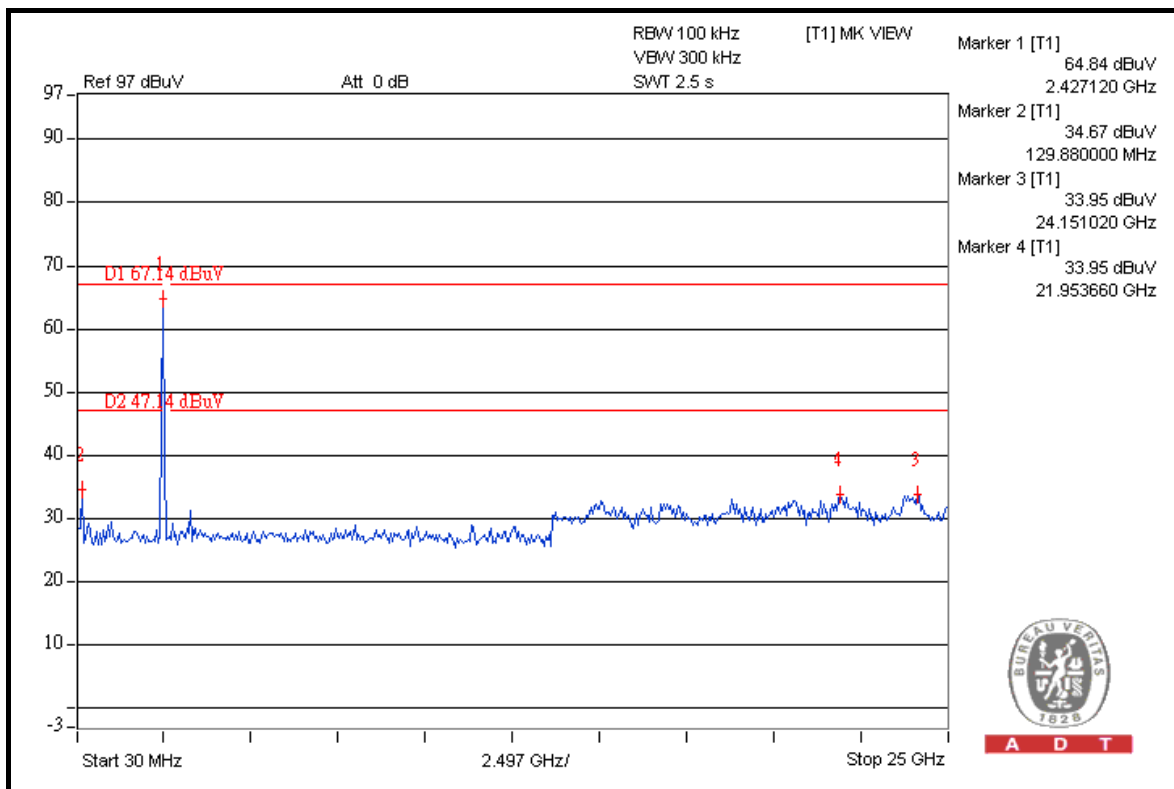
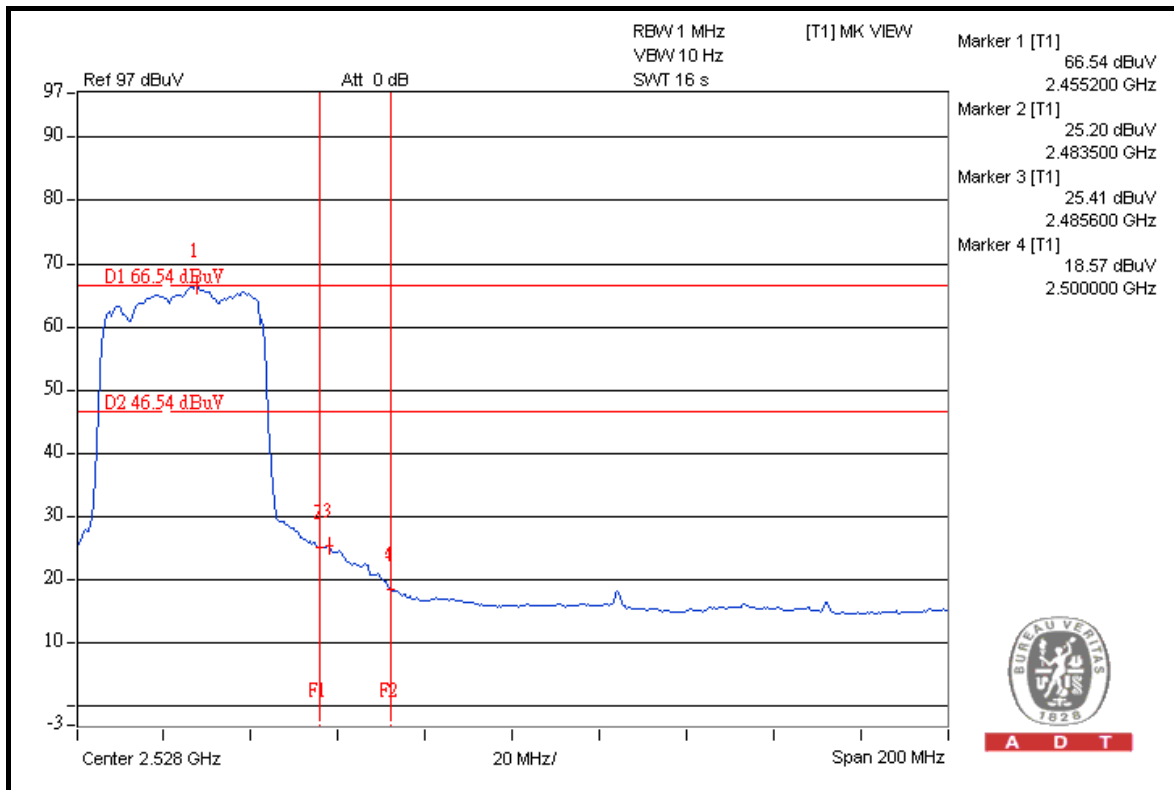





A D T

## TEST MDOE C

### RESTRICT BAND (2310 ~ 2390 MHz)

FREQUENCY (MHz)	FUNDAMENTAL EMISSION (dBuV/m)	DELTA (dB)	MAXIMUM FIELD STRENGTH IN RESTRICT BAND (dBuV/m)	LIMIT (dBuV/m)
2422.00 (PK)	104.5	41.30	63.20	74.00
2422.00 (AV)	93.3	45.41	47.89	54.00

### RESTRICT BAND (2483.5 ~ 2500 MHz)

FREQUENCY (MHz)	FUNDAMENTAL EMISSION (dBuV/m)	DELTA (dB)	MAXIMUM FIELD STRENGTH IN RESTRICT BAND (dBuV/m)	LIMIT (dBuV/m)
2452.00 (PK)	103.2	40.37	62.83	74.00
2452.00 (AV)	92.2	43.95	48.25	54.00

#### NOTE:

1. Delta = Amplitude between the peak of the fundamental and the peak of the band edge emission. Please check following 3 pages.
2. Maximum field strength in restrict band = Fundamental emission – Delta.



A D T

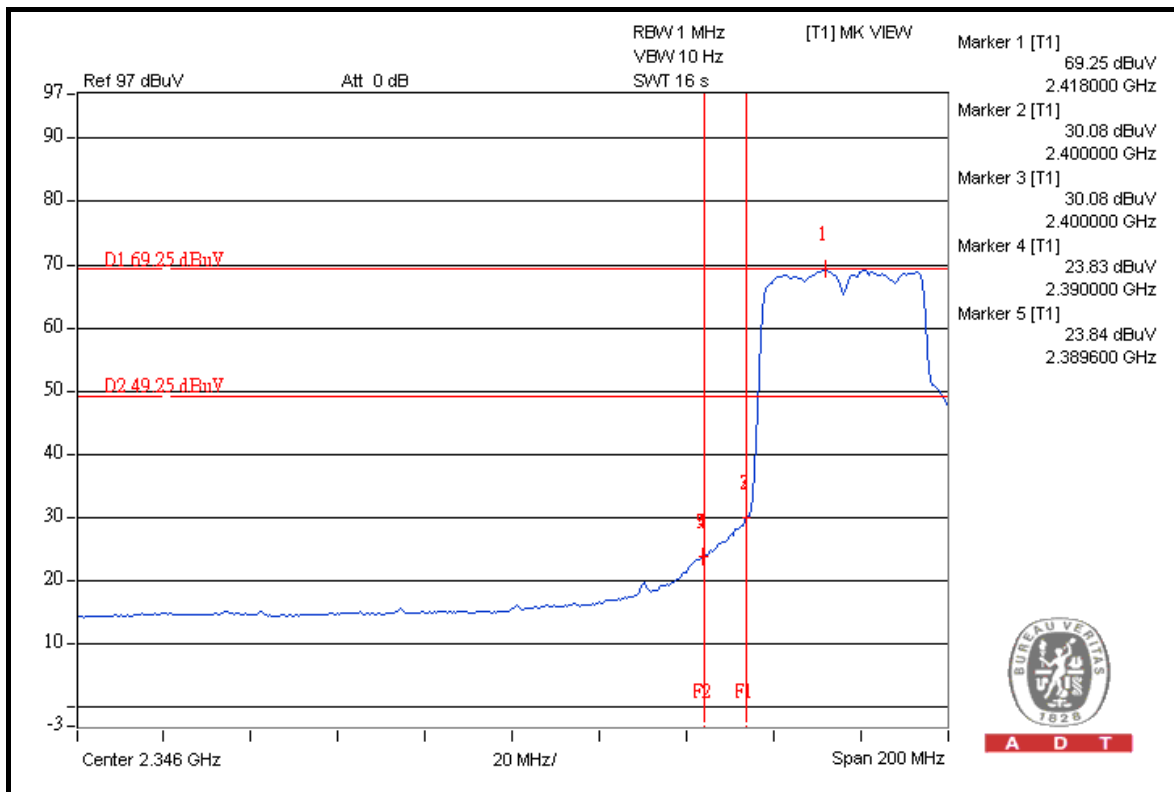
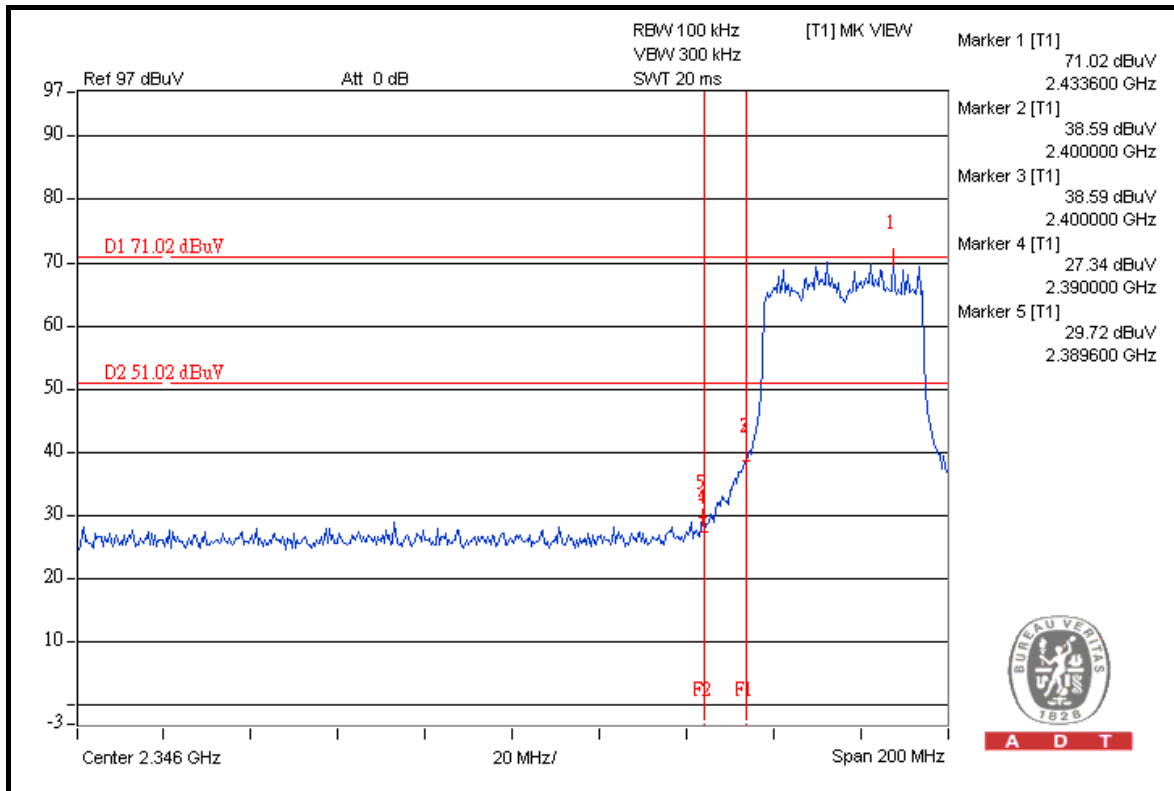



A D T

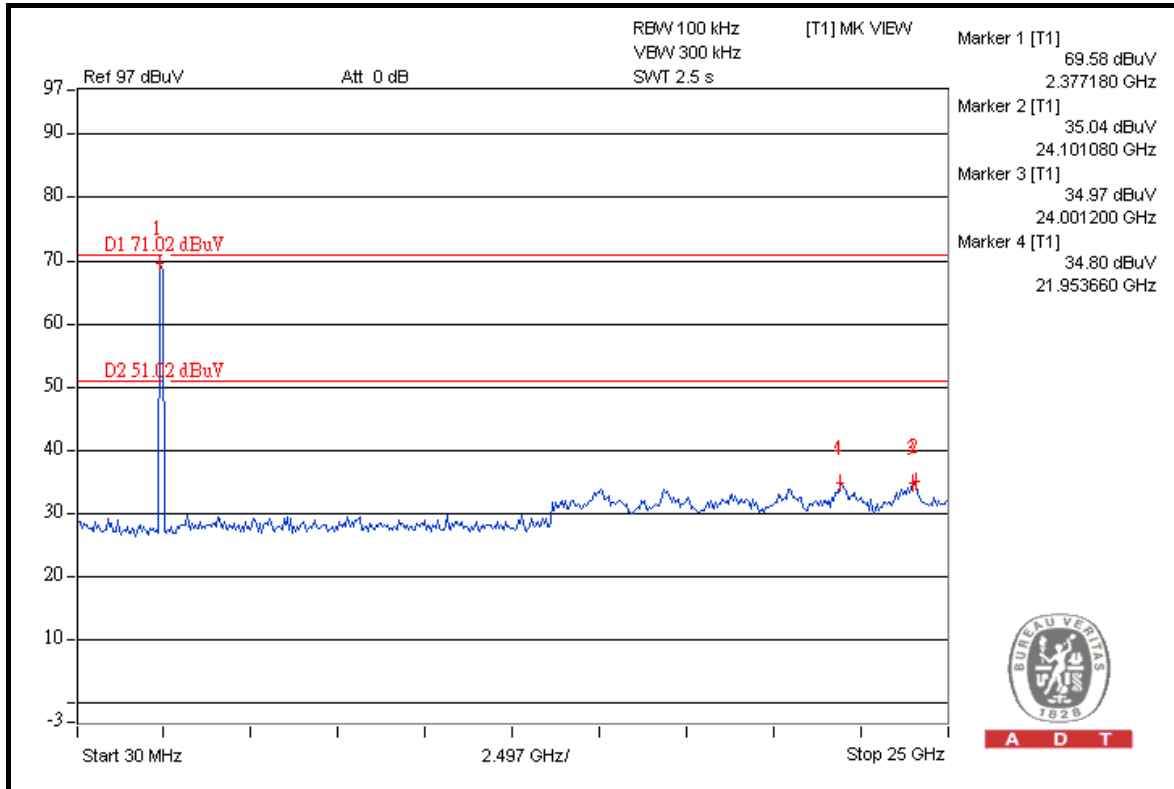

A D T

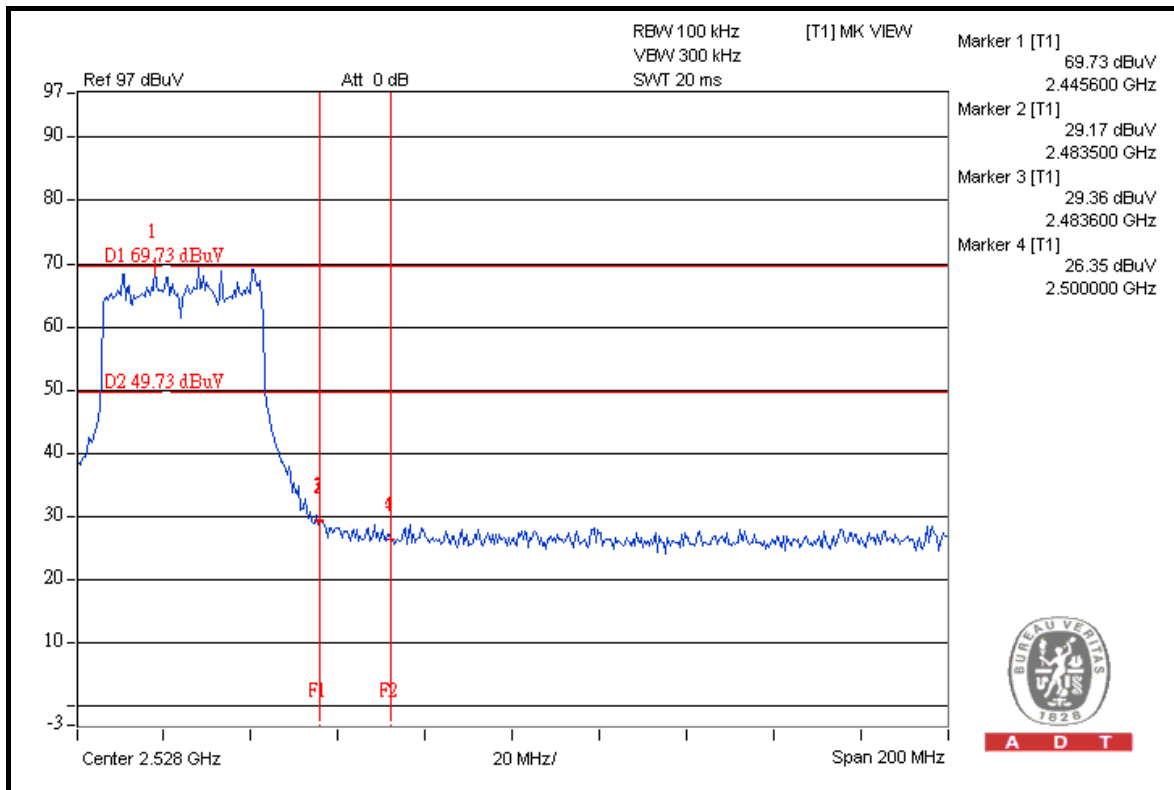

A D T



A D T

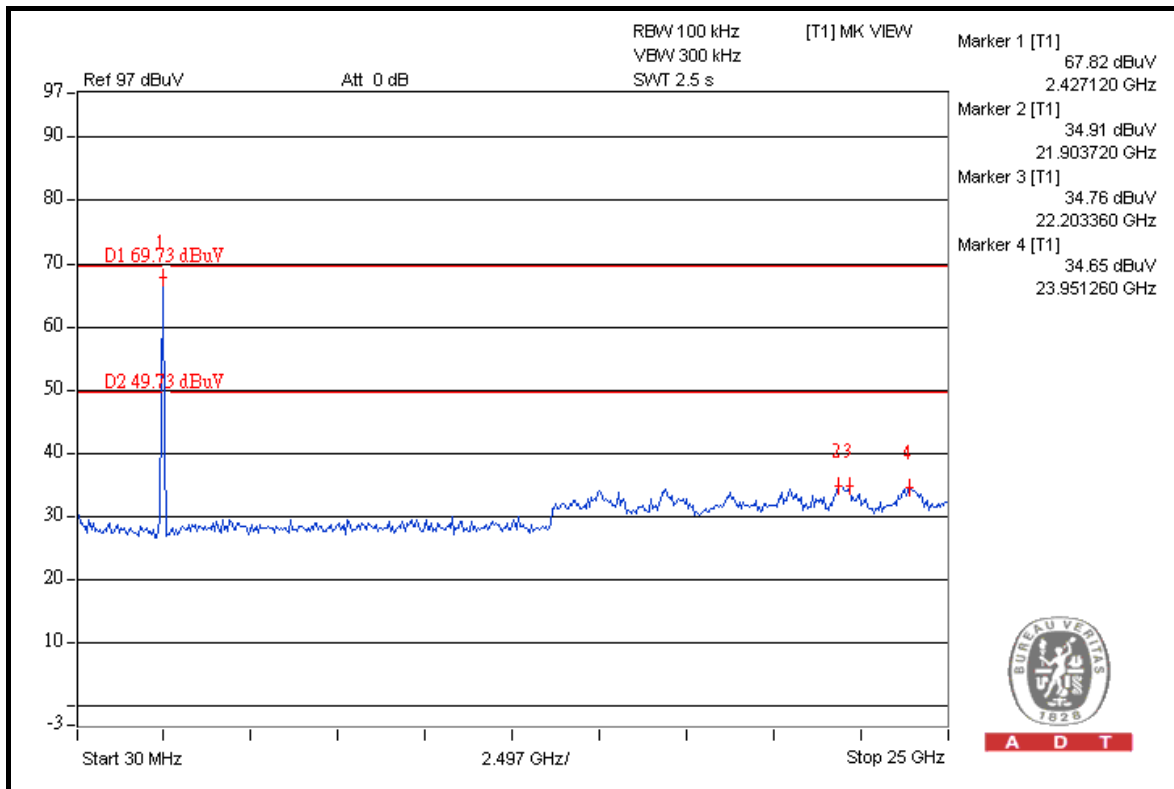
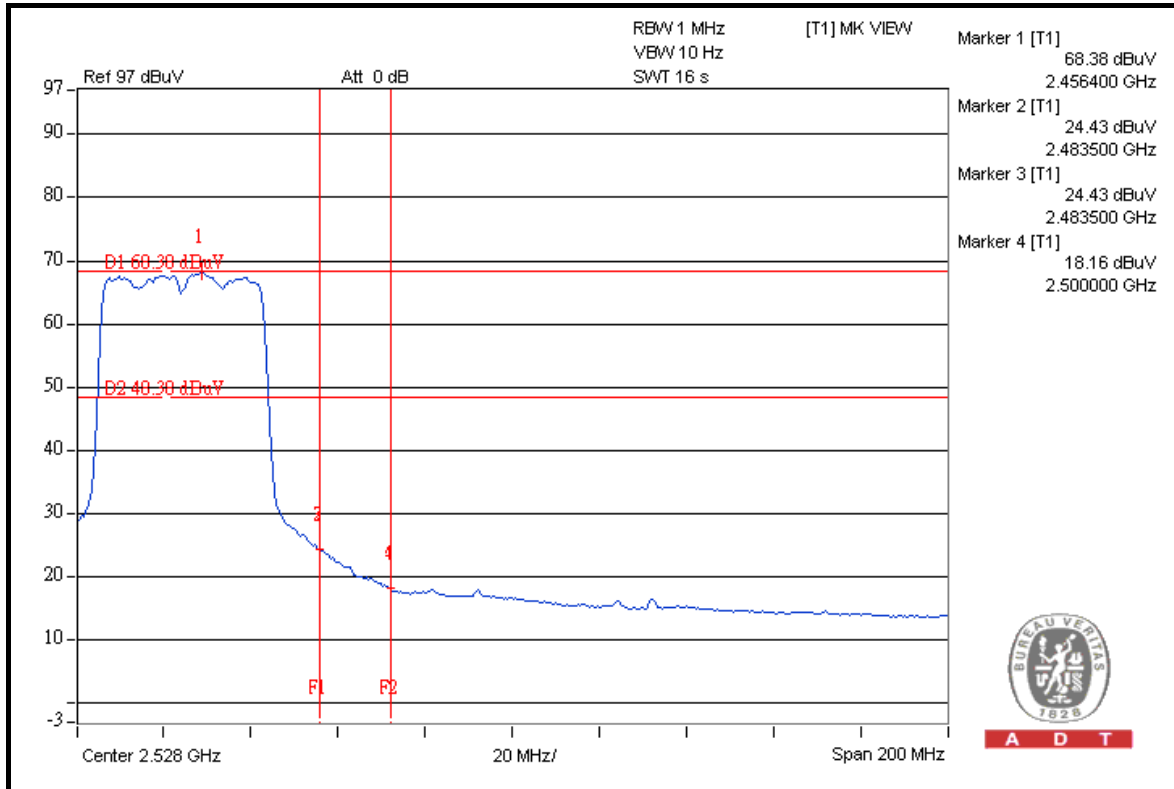



A D T

## 5. TEST TYPES AND RESULTS (FOR 5.0GHz BAND)

### 5.1 RADIATED EMISSION MEASUREMENT

#### 5.1.1 LIMITS OF RADIATED EMISSION MEASUREMENT

Emissions radiated outside of the specified bands, shall be according to the general radiated limits in 15.209 as following:

FREQUENCIES (MHz)	FIELD STRENGTH (microvolts/meter)	MEASUREMENT DISTANCE (meters)
0.009 ~ 0.490	2400/F(kHz)	300
0.490 ~ 1.705	24000/F(kHz)	30
1.705 ~ 30.0	30	30
30 ~ 88	100	3
88 ~ 216	150	3
216 ~ 960	200	3
Above 960	500	3

**NOTE:**

1. The lower limit shall apply at the transition frequencies.
2. Emission level (dBuV/m) = 20 log Emission level (uV/m).
3. As shown in 15.35(b), for frequencies above 1000MHz, the field strength limits are based on average detector, however, the peak field strength of any emission shall not exceed the maximum permitted average limits, specified above by more than 20dB under any condition of modulation.



A D T

### 5.1.2 TEST INSTRUMENTS

DESCRIPTION & MANUFACTURER	MODEL NO.	SERIAL NO.	DATE OF CALIBRATION	DUE DATE OF CALIBRATION
Test Receiver ROHDE & SCHWARZ	ESI7	838496/016	Dec. 29, 2009	Dec. 28, 2010
Spectrum Analyzer ROHDE & SCHWARZ	FSP40	100039	Jan. 11, 2010	Jan. 10, 2011
BILOG Antenna SCHWARZBECK	VULB9168	9168-155	Apr. 28, 2010	Apr. 27, 2011
HORN Antenna SCHWARZBECK	BBHA 9120D	9120D-408	Jan. 05, 2010	Jan. 04, 2011
HORN Antenna SCHWARZBECK	BBHA 9170	BBHA9170242	Dec. 25, 2009	Dec. 24, 2010
Preamplifier Agilent	8449B	3008A01961	Nov. 04, 2009	Nov. 03, 2010
Preamplifier Agilent	8447D	2944A10738	Nov. 04, 2009	Nov. 03, 2010
RF signal cable HUBER+SUHNNER	SUCOFLEX 104	238141/4	May 14, 2010	May 13, 2011
RF signal cable HUBER+SUHNNER	SUCOFLEX 104	12738/6	May 14, 2010	May 13, 2011
Software ADT.	ADT_Radiated_ V7.6.15.9.2	NA	NA	NA
Antenna Tower inn-co GmbH	MA 4000	010303	NA	NA
Antenna Tower Controller inn-co GmbH	CO2000	019303	NA	NA
Turn Table ADT.	TT100.	TT93021704	NA	NA
Turn Table Controller ADT.	SC100.	SC93021704	NA	NA
26GHz ~ 40GHz Amplifier	EM26400	07026401	Jul. 02, 2010	Jul. 01, 2011

- NOTE:**
1. The calibration interval of the above test instruments is 12 months and the calibrations are traceable to NML/ROC and NIST/USA.
  2. The test was performed in HwaYa Chamber 4.
  3. The horn antenna and HP preamplifier (model: 8449B) are used only for the measurement of emission frequency above 1GHz if tested.
  4. The FCC Site Registration No. is 988962.
  5. The IC Site Registration No. is IC7450F-4.



### 5.1.3 TEST PROCEDURES

- a. The EUT was placed on the top of a rotating table 0.8 meters above the ground at a 3 meters semi-anechoic chamber. The table was rotated 360 degrees to determine the position of the highest radiation.
- b. The EUT was set 3 meters away from the interference-receiving antenna, which was mounted on the top of a variable-height antenna tower.
- c. The antenna is a broadband antenna, and its height is varied from one meter to four meters above the ground to determine the maximum value of the field strength. Both horizontal and vertical polarizations of the antenna are set to make the measurement.
- d. For each suspected emission, the EUT was arranged to its worst case and then the antenna was tuned to heights from 1 meter to 4 meters and the rotatable table was turned from 0 degrees to 360 degrees to find the maximum reading.
- e. The test-receiver system was set to Peak Detect Function and Specified Bandwidth with Maximum Hold Mode.
- f. If the emission level of the EUT in peak mode was lower than the limit specified, then testing could be stopped and the peak values of the EUT would be reported. Otherwise the emissions would be re-tested one by one using peak, quasi-peak or average method as specified and then reported in a data sheet.

**NOTE:**

1. The resolution bandwidth and video bandwidth of test receiver/spectrum analyzer is 120kHz for Quasi-peak detection at frequency below 1GHz.
2. The resolution bandwidth of test receiver/spectrum analyzer is 100kHz and video bandwidth is 300kHz for Peak detection at frequency above 1GHz.
3. The resolution bandwidth of test receiver/spectrum analyzer is 1MHz and the video bandwidth is 10Hz for Average detection (AV) at frequency above 1GHz.
4. All modes of operation were investigated and the worst-case emissions are reported.

### 5.1.4 DEVIATION FROM TEST STANDARD

No deviation

### 5.1.5 TEST SETUP

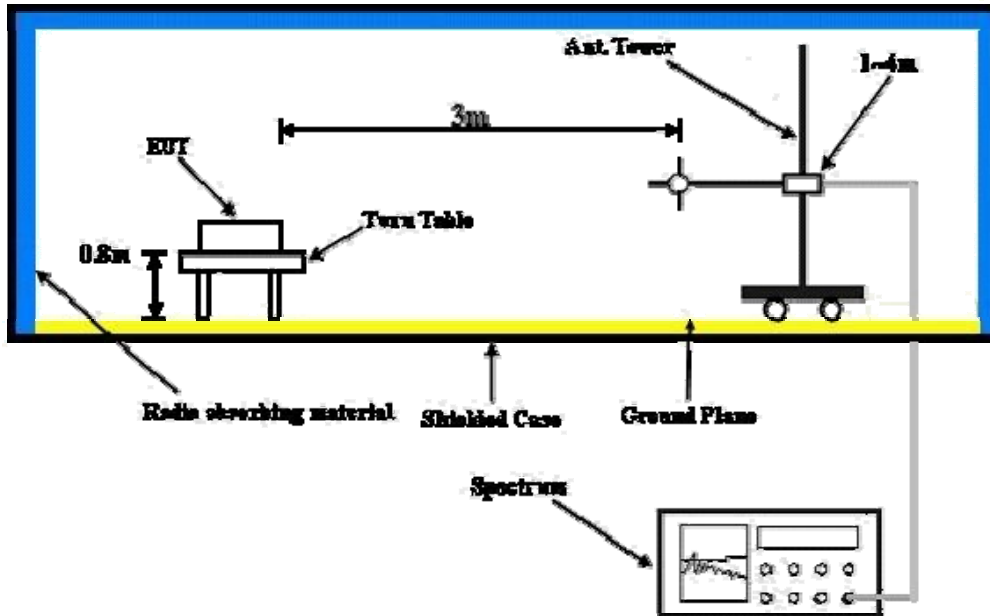

For the actual test configuration, please refer to the attached file (Test Setup Photo).

### 5.1.6 EUT OPERATING CONDITIONS

Same as 4.1.6





A D T

## 5.1.7 TEST RESULTS

### 802.11a

EUT TEST CONDITION		MEASUREMENT DETAIL	
CHANNEL	Channel 149	FREQUENCY RANGE	1 ~ 40GHz
INPUT POWER (SYSTEM)	120Vac, 60 Hz	DETECTOR FUNCTION	Peak (PK) Average (AV)
ENVIRONMENTAL CONDITIONS	28deg. C, 67%RH 1020 hPa	TESTED BY	Antony Lee

ANTENNA POLARITY & TEST DISTANCE: HORIZONTAL AT 3 M								
NO.	FREQ. (MHz)	EMISSION LEVEL (dBuV/m)	LIMIT (dBuV/m)	MARGIN (dB)	ANTENNA HEIGHT (m)	TABLE ANGLE (Degree)	RAW VALUE (dBuV)	CORRECTION FACTOR (dB/m)
1	#5725.00	79.4 PK	87.1	-7.7	1.34 H	334	37.80	41.60
2	#5725.00	57.8 AV	76.3	-18.5	1.34 H	334	16.20	41.60
3	*5745.00	107.1 PK			1.34 H	330	65.50	41.60
4	*5745.00	96.3 AV			1.34 H	330	54.70	41.60
5	11490.00	65.4 PK	74.0	-8.6	1.68 H	165	12.10	53.30
6	11490.00	52.7 AV	54.0	-1.3	1.68 H	165	-0.60	53.30
ANTENNA POLARITY & TEST DISTANCE: VERTICAL AT 3 M								
NO.	FREQ. (MHz)	EMISSION LEVEL (dBuV/m)	LIMIT (dBuV/m)	MARGIN (dB)	ANTENNA HEIGHT (m)	TABLE ANGLE (Degree)	RAW VALUE (dBuV)	CORRECTION FACTOR (dB/m)
1	#5725.00	90.2 PK	98.7	-8.5	1.00 V	28	48.60	41.60
2	#5725.00	69.3 AV	87.6	-18.3	1.00 V	28	27.70	41.60
3	*5745.00	118.7 PK			1.00 V	22	77.10	41.60
4	*5745.00	107.6 AV			1.00 V	22	66.00	41.60
5	11490.00	62.8 PK	74.0	-11.2	1.33 V	57	9.50	53.30
6	11490.00	51.0 AV	54.0	-3.0	1.33 V	57	-2.30	53.30

- REMARKS:**
1. Emission level (dBuV/m) = Raw Value (dBuV) + Correction Factor (dB/m).
  2. Correction Factor (dB/m) = Antenna Factor (dB/m) + Cable Factor (dB).
  3. The other emission levels were very low against the limit.
  4. Margin value = Emission level – Limit value.
  5. “ \* “: Fundamental frequency.
  6. The limit value is defined as per 15.247.
  7. "#":The radiated frequency is out the restricted band.



A D T

EUT TEST CONDITION		MEASUREMENT DETAIL	
CHANNEL	Channel 157	FREQUENCY RANGE	1 ~ 40GHz
INPUT POWER (SYSTEM)	120Vac, 60 Hz	DETECTOR FUNCTION	Peak (PK) Average (AV)
ENVIRONMENTAL CONDITIONS	28deg. C, 67%RH 1020 hPa	TESTED BY	Antony Lee

ANTENNA POLARITY & TEST DISTANCE: HORIZONTAL AT 3 M								
NO.	FREQ. (MHz)	EMISSION LEVEL (dBuV/m)	LIMIT (dBuV/m)	MARGIN (dB)	ANTENNA HEIGHT (m)	TABLE ANGLE (Degree)	RAW VALUE (dBuV)	CORRECTION FACTOR (dB/m)
1	*5785.00	108.8 PK			1.60 H	258	67.10	41.70
2	*5785.00	97.9 AV			1.60 H	258	56.20	41.70
3	11570.00	66.8 PK	74.0	-7.2	1.52 H	140	13.70	53.10
4	11570.00	52.8 AV	54.0	-1.2	1.52 H	140	-0.30	53.10
ANTENNA POLARITY & TEST DISTANCE: VERTICAL AT 3 M								
NO.	FREQ. (MHz)	EMISSION LEVEL (dBuV/m)	LIMIT (dBuV/m)	MARGIN (dB)	ANTENNA HEIGHT (m)	TABLE ANGLE (Degree)	RAW VALUE (dBuV)	CORRECTION FACTOR (dB/m)
1	*5785.00	119.7 PK			1.00 V	25	78.00	41.70
2	*5785.00	108.7 AV			1.00 V	25	67.00	41.70
3	11570.00	62.8 PK	74.0	-11.2	1.07 V	112	9.70	53.10
4	11570.00	50.5 AV	54.0	-3.5	1.07 V	112	-2.60	53.10

- REMARKS:**
1. Emission level (dBuV/m) = Raw Value (dBuV) + Correction Factor (dB/m).
  2. Correction Factor (dB/m) = Antenna Factor (dB/m) + Cable Factor (dB).
  3. The other emission levels were very low against the limit.
  4. Margin value = Emission level – Limit value.
  5. “ \* “: Fundamental frequency.
  6. The limit value is defined as per 15.247.



A D T

EUT TEST CONDITION		MEASUREMENT DETAIL	
CHANNEL	Channel 165	FREQUENCY RANGE	1 ~ 40GHz
INPUT POWER (SYSTEM)	120Vac, 60 Hz	DETECTOR FUNCTION	Peak (PK) Average (AV)
ENVIRONMENTAL CONDITIONS	28deg. C, 67%RH 1020 hPa	TESTED BY	Antony Lee

ANTENNA POLARITY & TEST DISTANCE: HORIZONTAL AT 3 M								
NO.	FREQ. (MHz)	EMISSION LEVEL (dBuV/m)	LIMIT (dBuV/m)	MARGIN (dB)	ANTENNA HEIGHT (m)	TABLE ANGLE (Degree)	RAW VALUE (dBuV)	CORRECTION FACTOR (dB/m)
1	*5825.00	106.5 PK			1.33 H	327	64.80	41.70
2	*5825.00	95.7 AV			1.33 H	327	54.00	41.70
3	#5850.00	71.3 PK	86.5	-15.2	1.33 H	327	29.60	41.70
4	#5850.00	49.8 AV	75.7	-25.9	1.33 H	327	8.10	41.70
5	11650.00	66.2 PK	74.0	-7.8	1.33 H	258	13.10	53.10
6	11650.00	53.0 AV	54.0	-1.0	1.33 H	258	-0.10	53.10
ANTENNA POLARITY & TEST DISTANCE: VERTICAL AT 3 M								
NO.	FREQ. (MHz)	EMISSION LEVEL (dBuV/m)	LIMIT (dBuV/m)	MARGIN (dB)	ANTENNA HEIGHT (m)	TABLE ANGLE (Degree)	RAW VALUE (dBuV)	CORRECTION FACTOR (dB/m)
1	*5825.00	117.7 PK			1.00 V	22	76.00	41.70
2	*5825.00	107.7 AV			1.00 V	22	66.00	41.70
3	#5850.00	82.5 PK	97.7	-15.2	1.00 V	23	40.80	41.70
4	#5850.00	64.8 AV	87.7	-22.9	1.00 V	23	23.10	41.70
5	11650.00	62.3 PK	74.0	-11.7	1.07 V	228	9.20	53.10
6	11650.00	50.5 AV	54.0	-3.5	1.07 V	228	-2.60	53.10

- REMARKS:**
1. Emission level (dBuV/m) = Raw Value (dBuV) + Correction Factor (dB/m).
  2. Correction Factor (dB/m) = Antenna Factor (dB/m) + Cable Factor (dB).
  3. The other emission levels were very low against the limit.
  4. Margin value = Emission level – Limit value.
  5. “ \* “: Fundamental frequency.
  6. The limit value is defined as per 15.247.
  7. “#”:The radiated frequency is out the restricted band.



A D T

802.11n (20MHz)

EUT TEST CONDITION		MEASUREMENT DETAIL	
CHANNEL	Channel 149	FREQUENCY RANGE	1 ~ 40GHz
INPUT POWER (SYSTEM)	120Vac, 60 Hz	DETECTOR FUNCTION	Peak (PK) Average (AV)
ENVIRONMENTAL CONDITIONS	28deg. C, 67%RH 1020 hPa	TESTED BY	Antony Lee

ANTENNA POLARITY & TEST DISTANCE: HORIZONTAL AT 3 M								
NO.	FREQ. (MHz)	EMISSION LEVEL (dBuV/m)	LIMIT (dBuV/m)	MARGIN (dB)	ANTENNA HEIGHT (m)	TABLE ANGLE (Degree)	RAW VALUE (dBuV)	CORRECTION FACTOR (dB/m)
1	#5725.00	79.2 PK	87.0	-7.8	1.28 H	320	37.60	41.60
2	#5725.00	57.2 AV	76.2	-19.0	1.28 H	320	15.60	41.60
3	*5745.00	107.0 PK			1.28 H	320	65.40	41.60
4	*5745.00	96.2 AV			1.28 H	320	54.60	41.60
5	11490.00	66.8 PK	74.0	-7.2	1.61 H	258	13.50	53.30
6	11490.00	52.7 AV	54.0	-1.3	1.61 H	258	-0.60	53.30
ANTENNA POLARITY & TEST DISTANCE: VERTICAL AT 3 M								
NO.	FREQ. (MHz)	EMISSION LEVEL (dBuV/m)	LIMIT (dBuV/m)	MARGIN (dB)	ANTENNA HEIGHT (m)	TABLE ANGLE (Degree)	RAW VALUE (dBuV)	CORRECTION FACTOR (dB/m)
1	#5725.00	90.0 PK	98.3	-8.3	1.01 V	32	48.40	41.60
2	#5725.00	69.1 AV	87.2	-18.1	1.01 V	32	27.50	41.60
3	*5745.00	118.3 PK			1.01 V	32	76.70	41.60
4	*5745.00	107.2 AV			1.01 V	32	65.60	41.60
5	11490.00	62.7 PK	74.0	-11.3	1.27 V	108	9.40	53.30
6	11490.00	51.1 AV	54.0	-2.9	1.27 V	108	-2.20	53.30

- REMARKS:**
1. Emission level (dBuV/m) = Raw Value (dBuV) + Correction Factor (dB/m).
  2. Correction Factor (dB/m) = Antenna Factor (dB/m) + Cable Factor (dB).
  3. The other emission levels were very low against the limit.
  4. Margin value = Emission level – Limit value.
  5. “ \* “: Fundamental frequency.
  6. The limit value is defined as per 15.247.
  7. "#":The radiated frequency is out the restricted band.



A D T

EUT TEST CONDITION		MEASUREMENT DETAIL	
CHANNEL	Channel 157	FREQUENCY RANGE	1 ~ 40GHz
INPUT POWER (SYSTEM)	120Vac, 60 Hz	DETECTOR FUNCTION	Peak (PK) Average (AV)
ENVIRONMENTAL CONDITIONS	28deg. C, 67%RH 1020 hPa	TESTED BY	Antony Lee

ANTENNA POLARITY & TEST DISTANCE: HORIZONTAL AT 3 M								
NO.	FREQ. (MHz)	EMISSION LEVEL (dBuV/m)	LIMIT (dBuV/m)	MARGIN (dB)	ANTENNA HEIGHT (m)	TABLE ANGLE (Degree)	RAW VALUE (dBuV)	CORRECTION FACTOR (dB/m)
1	*5785.00	111.2 PK			1.00 H	322	69.50	41.70
2	*5785.00	100.3 AV			1.00 H	322	58.60	41.70
3	11570.00	68.0 PK	74.0	-6.0	1.51 H	139	14.90	53.10
4	11570.00	53.0 AV	54.0	-1.0	1.51 H	139	-0.10	53.10
ANTENNA POLARITY & TEST DISTANCE: VERTICAL AT 3 M								
NO.	FREQ. (MHz)	EMISSION LEVEL (dBuV/m)	LIMIT (dBuV/m)	MARGIN (dB)	ANTENNA HEIGHT (m)	TABLE ANGLE (Degree)	RAW VALUE (dBuV)	CORRECTION FACTOR (dB/m)
1	*5785.00	117.9 PK			1.00 V	23	76.20	41.70
2	*5785.00	107.2 AV			1.00 V	23	65.50	41.70
3	11570.00	62.2 PK	74.0	-11.8	1.60 V	237	9.10	53.10
4	11570.00	50.2 AV	54.0	-3.8	1.60 V	237	-2.90	53.10

- REMARKS:**
1. Emission level (dBuV/m) = Raw Value (dBuV) + Correction Factor (dB/m).
  2. Correction Factor (dB/m) = Antenna Factor (dB/m) + Cable Factor (dB).
  3. The other emission levels were very low against the limit.
  4. Margin value = Emission level – Limit value.
  5. “ \* “: Fundamental frequency.
  6. The limit value is defined as per 15.247.



A D T

EUT TEST CONDITION		MEASUREMENT DETAIL	
CHANNEL	Channel 165	FREQUENCY RANGE	1 ~ 40GHz
INPUT POWER (SYSTEM)	120Vac, 60 Hz	DETECTOR FUNCTION	Peak (PK) Average (AV)
ENVIRONMENTAL CONDITIONS	28deg. C, 67%RH 1020 hPa	TESTED BY	Antony Lee

ANTENNA POLARITY & TEST DISTANCE: HORIZONTAL AT 3 M								
NO.	FREQ. (MHz)	EMISSION LEVEL (dBuV/m)	LIMIT (dBuV/m)	MARGIN (dB)	ANTENNA HEIGHT (m)	TABLE ANGLE (Degree)	RAW VALUE (dBuV)	CORRECTION FACTOR (dB/m)
1	*5825.00	106.4 PK			1.27 H	288	64.70	41.70
2	*5825.00	95.5 AV			1.27 H	288	53.80	41.70
3	#5850.00	71.2 PK	86.4	-15.2	1.27 H	289	29.50	41.70
4	#5850.00	50.0 AV	75.5	-25.5	1.27 H	289	8.30	41.70
5	11650.00	67.8 PK	74.0	-6.2	1.32 H	256	14.70	53.10
6	11650.00	53.0 AV	54.0	-1.0	1.32 H	256	-0.10	53.10
ANTENNA POLARITY & TEST DISTANCE: VERTICAL AT 3 M								
NO.	FREQ. (MHz)	EMISSION LEVEL (dBuV/m)	LIMIT (dBuV/m)	MARGIN (dB)	ANTENNA HEIGHT (m)	TABLE ANGLE (Degree)	RAW VALUE (dBuV)	CORRECTION FACTOR (dB/m)
1	*5825.00	117.5 PK			1.01 V	23	75.80	41.70
2	*5825.00	107.5 AV			1.01 V	23	65.80	41.70
3	#5850.00	82.3 PK	97.5	-15.2	1.00 V	23	40.60	41.70
4	#5850.00	64.7 AV	87.5	-22.8	1.00 V	23	23.00	41.70
5	11650.00	62.7 PK	74.0	-11.3	1.12 V	153	9.60	53.10
6	11650.00	50.8 AV	54.0	-3.2	1.12 V	153	-2.30	53.10

- REMARKS:**
1. Emission level (dBuV/m) = Raw Value (dBuV) + Correction Factor (dB/m).
  2. Correction Factor (dB/m) = Antenna Factor (dB/m) + Cable Factor (dB).
  3. The other emission levels were very low against the limit.
  4. Margin value = Emission level – Limit value.
  5. “ \* “: Fundamental frequency.
  6. The limit value is defined as per 15.247.
  7. “#“: The radiated frequency is out the restricted band.



A D T

802.11n (40MHz)

EUT TEST CONDITION		MEASUREMENT DETAIL	
CHANNEL	Channel 151	FREQUENCY RANGE	1 ~ 40GHz
INPUT POWER (SYSTEM)	120Vac, 60 Hz	DETECTOR FUNCTION	Peak (PK) Average (AV)
ENVIRONMENTAL CONDITIONS	28deg. C, 67%RH 1020 hPa	TESTED BY	Antony Lee

ANTENNA POLARITY & TEST DISTANCE: HORIZONTAL AT 3 M								
NO.	FREQ. (MHz)	EMISSION LEVEL (dBuV/m)	LIMIT (dBuV/m)	MARGIN (dB)	ANTENNA HEIGHT (m)	TABLE ANGLE (Degree)	RAW VALUE (dBuV)	CORRECTION FACTOR (dB/m)
1	#5725.00	76.8 PK	86.8	-10.0	1.00 H	125	35.20	41.60
2	#5725.00	60.4 AV	75.5	-15.1	1.00 H	125	18.80	41.60
3	*5755.00	106.8 PK			1.20 H	286	65.10	41.70
4	*5755.00	95.5 AV			1.20 H	286	53.80	41.70
5	11510.00	65.9 PK	74.0	-8.1	1.52 H	139	12.60	53.30
6	11510.00	52.5 AV	54.0	-1.5	1.52 H	139	-0.80	53.30
ANTENNA POLARITY & TEST DISTANCE: VERTICAL AT 3 M								
NO.	FREQ. (MHz)	EMISSION LEVEL (dBuV/m)	LIMIT (dBuV/m)	MARGIN (dB)	ANTENNA HEIGHT (m)	TABLE ANGLE (Degree)	RAW VALUE (dBuV)	CORRECTION FACTOR (dB/m)
1	#5725.00	81.8 PK	96.3	-14.5	1.00 V	26	40.20	41.60
2	#5725.00	65.4 AV	86.4	-21.0	1.00 V	26	23.80	41.60
3	*5755.00	116.3 PK			1.00 V	27	74.60	41.70
4	*5755.00	106.4 AV			1.00 V	27	64.70	41.70
5	11510.00	62.8 PK	74.0	-11.2	1.22 V	77	9.50	53.30
6	11510.00	51.0 AV	54.0	-3.0	1.22 V	77	-2.30	53.30

- REMARKS:**
1. Emission level (dBuV/m) = Raw Value (dBuV) + Correction Factor (dB/m).
  2. Correction Factor (dB/m) = Antenna Factor (dB/m) + Cable Factor (dB).
  3. The other emission levels were very low against the limit.
  4. Margin value = Emission level – Limit value.
  5. “ \* “: Fundamental frequency.
  6. The limit value is defined as per 15.247.
  7. "#":The radiated frequency is out the restricted band.



A D T

EUT TEST CONDITION		MEASUREMENT DETAIL	
CHANNEL	Channel 159	FREQUENCY RANGE	1 ~ 40GHz
INPUT POWER (SYSTEM)	120Vac, 60 Hz	DETECTOR FUNCTION	Peak (PK) Average (AV)
ENVIRONMENTAL CONDITIONS	28deg. C, 67%RH 1020 hPa	TESTED BY	Antony Lee

ANTENNA POLARITY & TEST DISTANCE: HORIZONTAL AT 3 M								
NO.	FREQ. (MHz)	EMISSION LEVEL (dBuV/m)	LIMIT (dBuV/m)	MARGIN (dB)	ANTENNA HEIGHT (m)	TABLE ANGLE (Degree)	RAW VALUE (dBuV)	CORRECTION FACTOR (dB/m)
1	*5795.00	106.5 PK			1.17 H	287	64.80	41.70
2	*5795.00	95.2 AV			1.17 H	287	53.50	41.70
3	#5850.00	70.9 PK	86.5	-15.6	1.00 H	283	29.20	41.70
4	#5850.00	54.6 AV	75.2	-20.6	1.00 H	283	12.90	41.70
5	11590.00	64.9 PK	74.0	-9.1	1.63 H	143	11.80	53.10
6	11590.00	52.6 AV	54.0	-1.4	1.63 H	143	-0.50	53.10
ANTENNA POLARITY & TEST DISTANCE: VERTICAL AT 3 M								
NO.	FREQ. (MHz)	EMISSION LEVEL (dBuV/m)	LIMIT (dBuV/m)	MARGIN (dB)	ANTENNA HEIGHT (m)	TABLE ANGLE (Degree)	RAW VALUE (dBuV)	CORRECTION FACTOR (dB/m)
1	*5795.00	116.0 PK			1.02 V	33	74.30	41.70
2	*5795.00	106.2 AV			1.02 V	33	64.50	41.70
3	#5850.00	75.9 PK	96.0	-20.1	1.00 V	37	34.20	41.70
4	#5850.00	59.0 AV	86.2	-27.2	1.00 V	37	17.30	41.70
5	11590.00	62.6 PK	74.0	-11.4	1.36 V	80	9.50	53.10
6	11590.00	51.2 AV	54.0	-2.8	1.36 V	80	-1.90	53.10

- REMARKS:**
1. Emission level (dBuV/m) = Raw Value (dBuV) + Correction Factor (dB/m).
  2. Correction Factor (dB/m) = Antenna Factor (dB/m) + Cable Factor (dB).
  3. The other emission levels were very low against the limit.
  4. Margin value = Emission level – Limit value.
  5. “ \* “: Fundamental frequency.
  6. The limit value is defined as per 15.247.
  7. "#":The radiated frequency is out the restricted band.





A D T

**BELOW 1GHz WORST-CASE DATA : 802.11a**

EUT TEST CONDITION		MEASUREMENT DETAIL	
CHANNEL	Channel 157	FREQUENCY RANGE	Below 1000MHz
INPUT POWER (SYSTEM)	120Vac, 60 Hz	DETECTOR FUNCTION	Quasi-Peak
ENVIRONMENTAL CONDITIONS	25deg. C, 65%RH 1008 hPa	TEST MODE	A
TESTED BY	Brad Wu		

ANTENNA POLARITY & TEST DISTANCE: HORIZONTAL AT 3 M								
NO.	FREQ. (MHz)	EMISSION LEVEL (dBuV/m)	LIMIT (dBuV/m)	MARGIN (dB)	ANTENNA HEIGHT (m)	TABLE ANGLE (Degree)	RAW VALUE (dBuV)	CORRECTION FACTOR (dB/m)
1	374.04	43.0 QP	46.0	-3.0	2.50 H	202	26.50	16.50
2	500.42	42.0 QP	46.0	-4.0	1.75 H	223	22.20	19.80
3	624.85	41.3 QP	46.0	-4.7	1.25 H	346	18.90	22.40
4	720.12	44.3 QP	46.0	-1.7	1.00 H	205	20.50	23.80
5	751.23	41.0 QP	46.0	-5.0	1.00 H	154	16.90	24.10
6	867.89	40.3 QP	46.0	-5.7	1.50 H	349	14.80	25.50
ANTENNA POLARITY & TEST DISTANCE: VERTICAL AT 3 M								
NO.	FREQ. (MHz)	EMISSION LEVEL (dBuV/m)	LIMIT (dBuV/m)	MARGIN (dB)	ANTENNA HEIGHT (m)	TABLE ANGLE (Degree)	RAW VALUE (dBuV)	CORRECTION FACTOR (dB/m)
1	158.22	40.9 QP	43.5	-2.6	1.00 V	166	26.30	14.60
2	399.31	43.2 QP	46.0	-2.8	1.25 V	151	26.10	17.10
3	500.42	44.2 QP	46.0	-1.8	1.00 V	49	24.40	19.80
4	751.23	43.7 QP	46.0	-2.3	1.50 V	331	19.60	24.10
5	875.67	41.8 QP	46.0	-4.2	1.00 V	10	16.20	25.60
6	912.61	44.5 QP	46.0	-1.5	1.00 V	241	18.40	26.10

- REMARKS:**
1. Emission level (dBuV/m) = Raw Value (dBuV) + Correction Factor (dB/m).
  2. Correction Factor (dB/m) = Antenna Factor (dB/m) + Cable Factor (dB).
  3. The other emission levels were very low against the limit.
  4. Margin value = Emission level – Limit value.



A D T

EUT TEST CONDITION		MEASUREMENT DETAIL	
CHANNEL	Channel 157	FREQUENCY RANGE	Below 1000MHz
INPUT POWER (SYSTEM)	120Vac, 60 Hz	DETECTOR FUNCTION	Quasi-Peak
ENVIRONMENTAL CONDITIONS	25deg. C, 65%RH 1008 hPa	TEST MODE	B
TESTED BY	Brad Wu		

ANTENNA POLARITY & TEST DISTANCE: HORIZONTAL AT 3 M								
NO.	FREQ. (MHz)	EMISSION LEVEL (dBuV/m)	LIMIT (dBuV/m)	MARGIN (dB)	ANTENNA HEIGHT (m)	TABLE ANGLE (Degree)	RAW VALUE (dBuV)	CORRECTION FACTOR (dB/m)
1	45.45	37.0 QP	40.0	-3.0	2.50 H	79	22.60	14.40
2	199.12	42.0 QP	43.5	-1.5	1.00 H	263	31.70	10.30
3	399.31	41.0 QP	46.0	-5.0	1.00 H	10	23.90	17.10
4	599.58	43.1 QP	46.0	-2.9	1.50 H	34	21.10	22.00
5	720.12	42.9 QP	46.0	-3.1	1.00 H	175	19.10	23.80
6	904.83	44.2 QP	46.0	-1.8	2.00 H	250	18.20	26.00
ANTENNA POLARITY & TEST DISTANCE: VERTICAL AT 3 M								
NO.	FREQ. (MHz)	EMISSION LEVEL (dBuV/m)	LIMIT (dBuV/m)	MARGIN (dB)	ANTENNA HEIGHT (m)	TABLE ANGLE (Degree)	RAW VALUE (dBuV)	CORRECTION FACTOR (dB/m)
1	35.83	39.0 QP	40.0	-1.0	1.00 V	270	26.30	12.70
2	199.05	37.2 QP	43.5	-6.3	1.00 V	295	26.90	10.30
3	400.00	44.7 QP	46.0	-1.3	1.22 V	42	27.60	17.10
4	599.58	36.5 QP	46.0	-9.5	1.00 V	88	14.50	22.00
5	799.84	41.6 QP	46.0	-4.4	1.25 V	292	17.00	24.60
6	961.21	40.7 QP	54.0	-13.3	1.00 V	19	13.90	26.80

- REMARKS:**
1. Emission level (dBuV/m) = Raw Value (dBuV) + Correction Factor (dB/m).
  2. Correction Factor (dB/m) = Antenna Factor (dB/m) + Cable Factor (dB).
  3. The other emission levels were very low against the limit.
  4. Margin value = Emission level – Limit value.



A D T

## 5.2 CONDUCTED EMISSION MEASUREMENT

### 5.2.1 LIMITS OF CONDUCTED EMISSION MEASUREMENT

FREQUENCY OF EMISSION (MHz)	CONDUCTED LIMIT (dB $\mu$ V)	
	Quasi-peak	Average
0.15 ~ 0.5	66 to 56	56 to 46
0.5 ~ 5	56	46
5 ~ 30	60	50

- NOTE:** 1. The lower limit shall apply at the transition frequencies.  
2. The limit decreases in line with the logarithm of the frequency in the range of 0.15 to 0.50MHz.  
3. All emanations from a class A/B digital device or system, including any network of conductors and apparatus connected thereto, shall not exceed the level of field strengths specified above.

### 5.2.2 TEST INSTRUMENTS

DESCRIPTION & MANUFACTURER	MODEL NO.	SERIAL NO.	DATE OF CALIBRATION	DUE DATE OF CALIBRATION
Test Receiver ROHDE & SCHWARZ	ESCS30	100291	Dec. 16, 2009	Dec. 15, 2010
RF signal cable Woken	5D-FB	Cable-HYC01-01	Nov. 12, 2009	Nov. 11, 2010
LISN ROHDE & SCHWARZ	ESH3-Z5	100312	Jun. 28, 2010	Jun. 27, 2011
LISN ROHDE & SCHWARZ	ESH3-Z5	835239/001	Feb. 10, 2010	Feb. 09, 2011
Software ADT	ADT_Cond_ V7.3.7	NA	NA	NA

- NOTE:** 1. The calibration interval of the above test instruments is 12 months and the calibrations are traceable to NML/ROC and NIST/USA.  
2. The test was performed in HwaYa Shielded Room 1.  
3. The VCCI Site Registration No. is C-2040.



A D T

### 5.2.3 TEST PROCEDURES

- a. The EUT was placed 0.4 meters from the conducting wall of the shielded room with EUT being connected to the power mains through a line impedance stabilization network (LISN). Other support units were connected to the power mains through another LISN. The two LISNs provide 50 ohm/ 50uH of coupling impedance for the measuring instrument.
- b. Both lines of the power mains connected to the EUT were checked for maximum conducted interference.
- c. The frequency range from 150kHz to 30MHz was searched. Emission levels under (Limit - 20dB) was not recorded.

### 5.2.4 DEVIATION FROM TEST STANDARD

No deviation

## 5.2.5 TEST SETUP

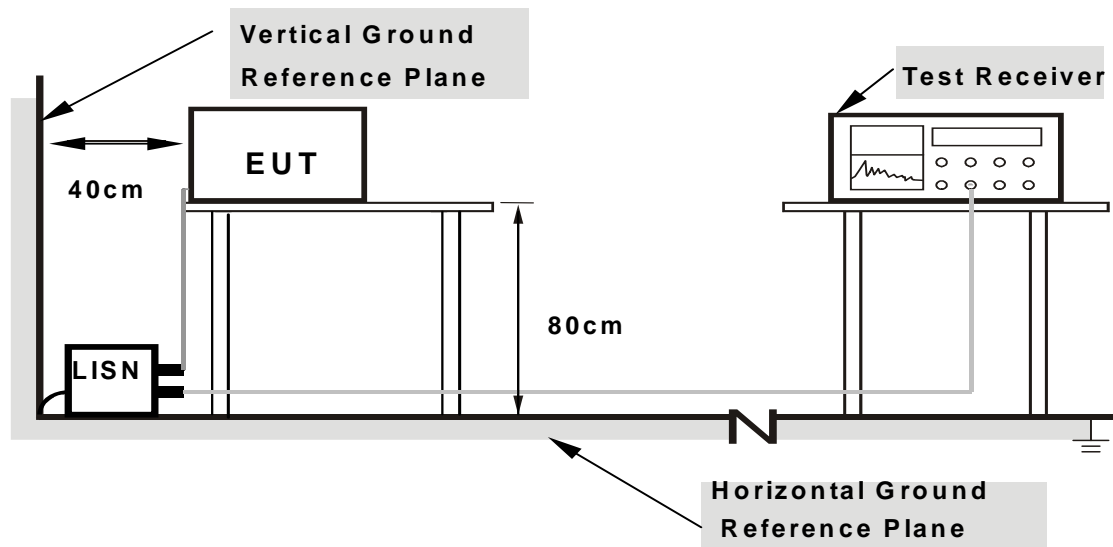

- Note:**
1. Support units were connected to second LISN.
  2. Both of LISNs (AMN) are 80 cm from EUT and at least 80 from other units and other metal planes

For the actual test configuration, please refer to the attached file (Test Setup Photo).

## 5.2.6 EUT OPERATING CONDITIONS

Same as 4.1.6

### 5.2.7 TEST RESULTS

CONDUCTED WORST-CASE DATA : 802.11a

PHASE	Line 1	6dB BANDWIDTH	9kHz
TEST MODE	A		

No	Freq. [MHz]	Corr. Factor (dB)	Reading Value		Emission Level		Limit		Margin	
			[dB (uV)]		[dB (uV)]		[dB (uV)]		(dB)	
			Q.P.	AV.	Q.P.	AV.	Q.P.	AV.	Q.P.	AV.
1	0.179	0.11	55.78	43.52	55.89	43.63	64.55	54.55	-8.66	-10.92
2	0.248	0.11	47.23	-	47.34	-	61.84	51.84	-14.49	-
3	0.306	0.12	41.82	-	41.94	-	60.07	50.07	-18.13	-
4	0.552	0.14	39.43	-	39.57	-	56.00	46.00	-16.43	-
5	1.699	0.23	27.64	-	27.87	-	56.00	46.00	-28.13	-
6	13.371	0.92	29.22	-	30.14	-	60.00	50.00	-29.86	-

- REMARKS:**
1. Q.P. and AV. are abbreviations of quasi-peak and average individually.
  2. "-": The Quasi-peak reading value also meets average limit and measurement with the average detector is unnecessary.
  3. The emission levels of other frequencies were very low against the limit.
  4. Margin value = Emission level - Limit value
  5. Correction factor = Insertion loss + Cable loss
  6. Emission Level = Correction Factor + Reading Value.

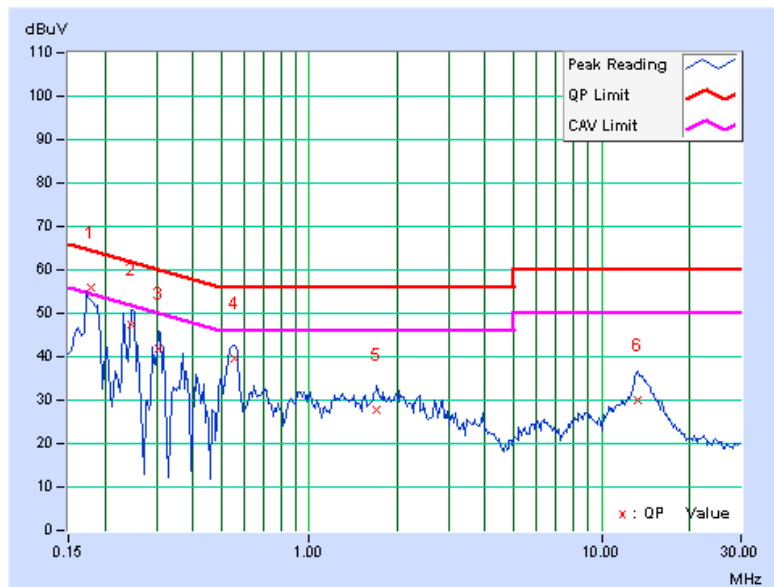



A D T

PHASE	Line 2	6dB BANDWIDTH	9kHz
TEST MODE	A		

No	Freq. [MHz]	Corr. Factor (dB)	Reading Value		Emission Level		Limit		Margin	
			[dB (uV)]		[dB (uV)]		[dB (uV)]		(dB)	
			Q.P.	AV.	Q.P.	AV.	Q.P.	AV.	Q.P.	AV.
1	0.185	0.10	53.75	-	53.85	-	64.25	54.25	-10.40	-
2	0.238	0.10	46.76	-	46.86	-	62.15	52.15	-15.29	-
3	0.310	0.11	40.08	-	40.19	-	59.97	49.97	-19.78	-
4	0.552	0.13	32.47	-	32.60	-	56.00	46.00	-23.40	-
5	2.129	0.25	24.07	-	24.32	-	56.00	46.00	-31.68	-
6	13.570	0.82	29.38	-	30.20	-	60.00	50.00	-29.80	-

- REMARKS:**
1. Q.P. and AV. are abbreviations of quasi-peak and average individually.
  2. "-": The Quasi-peak reading value also meets average limit and measurement with the average detector is unnecessary.
  3. The emission levels of other frequencies were very low against the limit.
  4. Margin value = Emission level - Limit value
  5. Correction factor = Insertion loss + Cable loss
  6. Emission Level = Correction Factor + Reading Value.

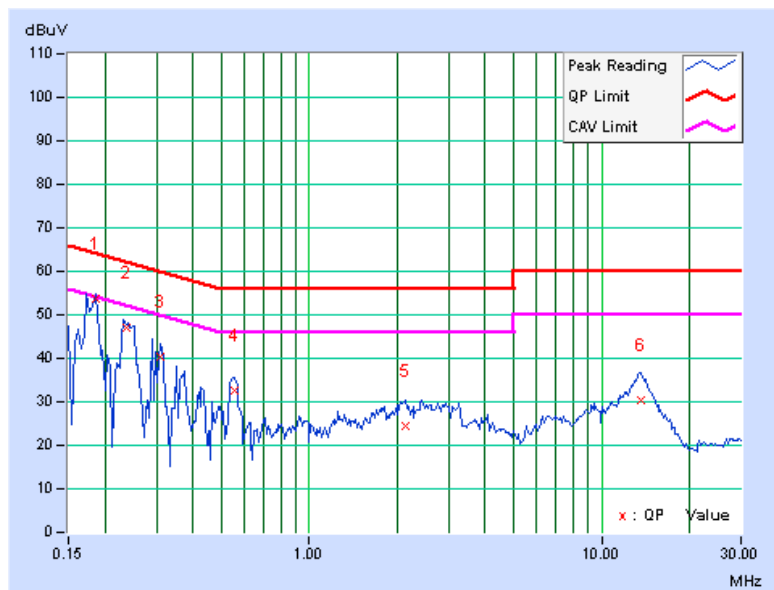

PHASE	Line 1	6dB BANDWIDTH	9kHz
TEST MODE	B		

No	Freq. [MHz]	Corr. Factor (dB)	Reading Value		Emission Level		Limit		Margin	
			[dB (uV)]		[dB (uV)]		[dB (uV)]		(dB)	
			Q.P.	AV.	Q.P.	AV.	Q.P.	AV.	Q.P.	AV.
1	0.181	0.11	45.94	-	46.05	-	64.43	54.43	-18.38	-
2	0.271	0.12	39.67	-	39.79	-	61.08	51.08	-21.29	-
3	0.362	0.13	40.77	-	40.90	-	58.68	48.68	-17.78	-
4	0.720	0.16	32.85	-	33.01	-	56.00	46.00	-22.99	-
5	23.129	1.68	46.79	-	48.47	-	60.00	50.00	-11.53	-
6	29.113	2.02	49.31	46.88	51.33	48.90	60.00	50.00	-8.67	-1.10

- REMARKS:**
1. Q.P. and AV. are abbreviations of quasi-peak and average individually.
  2. "-": The Quasi-peak reading value also meets average limit and measurement with the average detector is unnecessary.
  3. The emission levels of other frequencies were very low against the limit.
  4. Margin value = Emission level - Limit value
  5. Correction factor = Insertion loss + Cable loss
  6. Emission Level = Correction Factor + Reading Value.

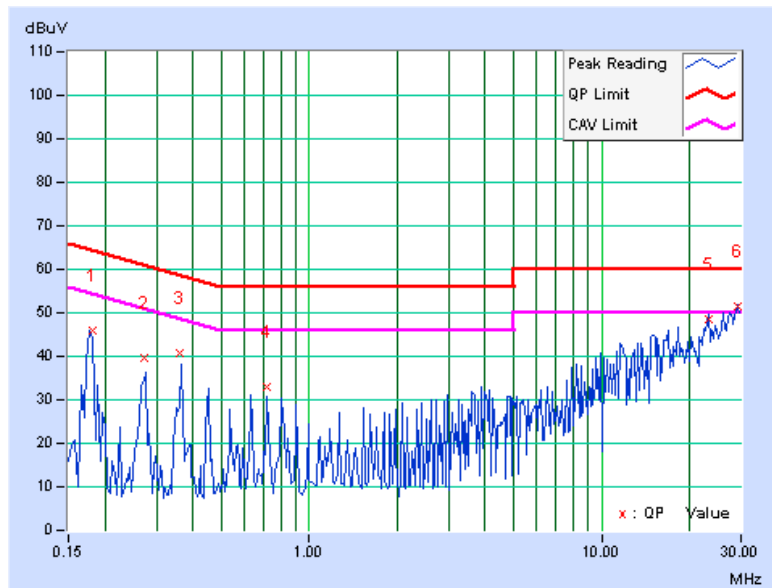





A D T

PHASE	Line 2	6dB BANDWIDTH	9kHz
TEST MODE	B		

No	Freq. [MHz]	Corr. Factor (dB)	Reading Value		Emission Level		Limit		Margin	
			[dB (uV)]		[dB (uV)]		[dB (uV)]		(dB)	
			Q.P.	AV.	Q.P.	AV.	Q.P.	AV.	Q.P.	AV.
1	0.179	0.10	48.98	-	49.08	-	64.55	54.55	-15.47	-
2	0.272	0.11	35.67	-	35.78	-	61.04	51.04	-25.27	-
3	0.361	0.12	37.02	-	37.14	-	58.71	48.71	-21.57	-
4	0.814	0.15	33.42	-	33.57	-	56.00	46.00	-22.43	-
5	23.129	1.47	48.64	47.05	50.11	48.52	60.00	50.00	-9.89	-1.48
6	29.113	1.76	49.18	47.23	50.94	48.99	60.00	50.00	-9.06	-1.01

- REMARKS:**
1. Q.P. and AV. are abbreviations of quasi-peak and average individually.
  2. "-": The Quasi-peak reading value also meets average limit and measurement with the average detector is unnecessary.
  3. The emission levels of other frequencies were very low against the limit.
  4. Margin value = Emission level - Limit value
  5. Correction factor = Insertion loss + Cable loss
  6. Emission Level = Correction Factor + Reading Value.

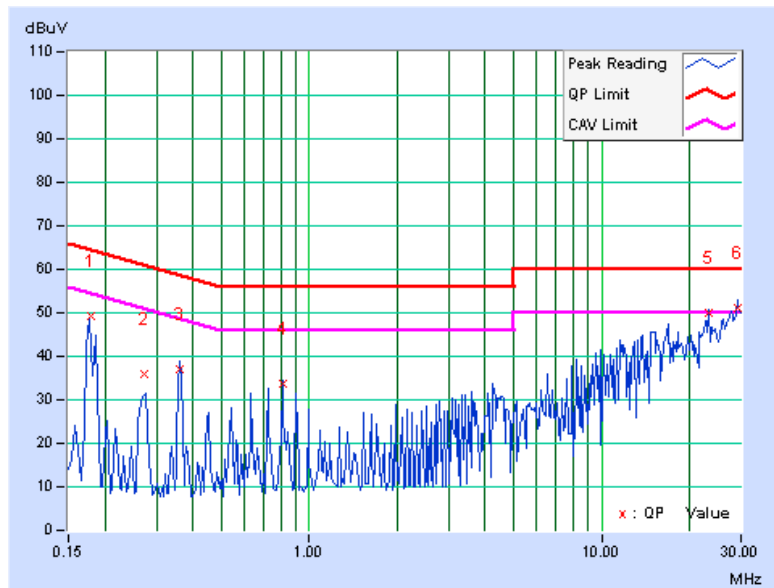



A D T

### 5.3 6dB BANDWIDTH MEASUREMENT

#### 5.3.1 LIMITS OF 6dB BANDWIDTH MEASUREMENT

The minimum of 6dB Bandwidth Measurement is 0.5MHz.

#### 5.3.2 TEST INSTRUMENTS

DESCRIPTION & MANUFACTURER	MODEL NO.	SERIAL NO.	DATE OF CALIBRATION	DUE DATE OF CALIBRATION
SPECTRUM ANALYZER R&S	FSP40	100039	Jan. 11, 2010	Jan. 10, 2011

**NOTE:** The calibration interval of the above test instruments is 12 months and the calibrations are traceable to NML/ROC and NIST/USA.

#### 5.3.3 TEST PROCEDURE

The transmitter output was connected to the spectrum analyzer through an attenuator. The bandwidth of the fundamental frequency was measured by spectrum analyzer with 100kHz RBW and 300kHz VBW. The 6dB bandwidth is defined as the total spectrum the power of which is higher than peak power minus 6dB.

### 5.3.4 DEVIATION FROM TEST STANDARD

No deviation

### 5.3.5 TEST SETUP

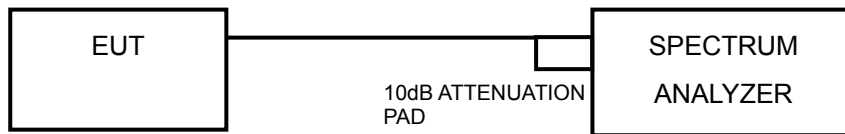

### 5.3.6 EUT OPERATING CONDITIONS

The software provided by client to enable the EUT under transmission condition continuously at lowest, middle and highest channel frequencies individually.



A D T

### 5.3.7 TEST RESULTS

#### 802.11a

CHANNEL	CHANNEL FREQUENCY (MHz)	6dB BANDWIDTH (MHz)		MINIMUM LIMIT (MHz)	PASS / FAIL
		CHAIN 0	CHAIN 1		
149	5745	16.41	16.38	0.5	PASS
157	5785	16.37	16.44	0.5	PASS
165	5825	16.43	16.41	0.5	PASS

#### CHAIN 1: CH 157

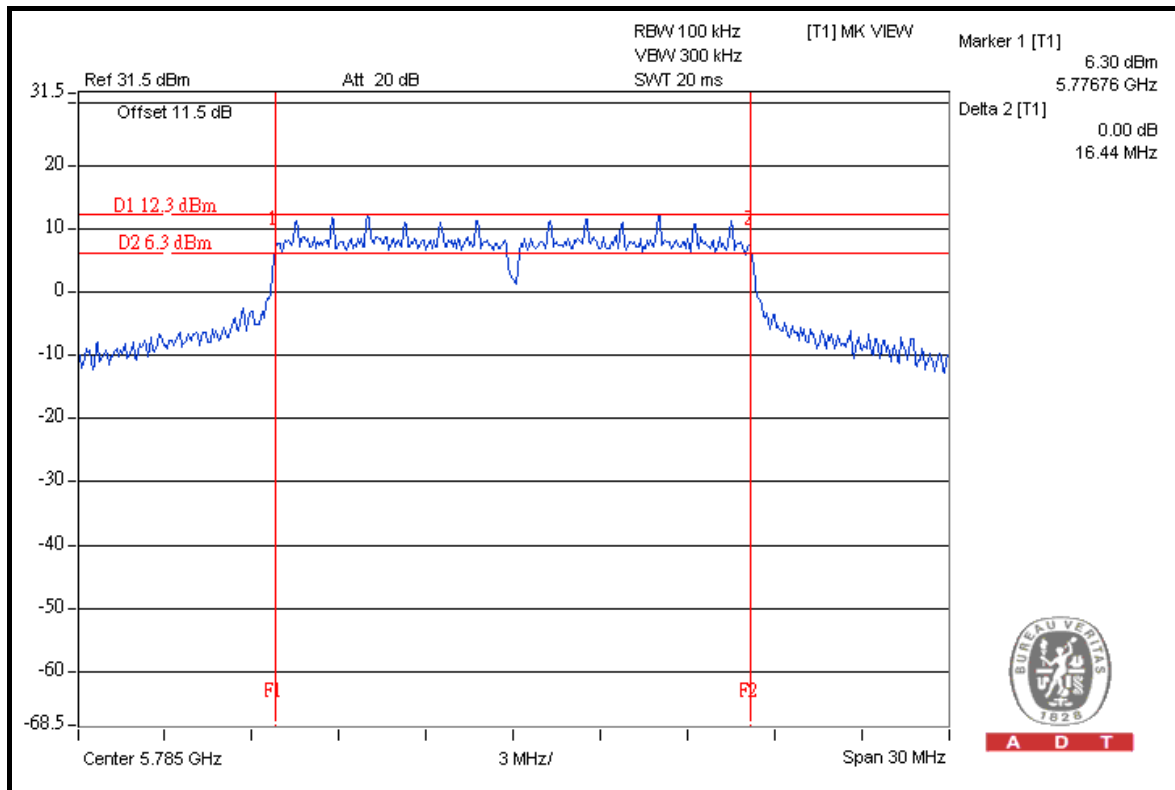



A D T

### 802.11n (20MHz)

CHANNEL	CHANNEL FREQUENCY (MHz)	6dB BANDWIDTH (MHz)		MINIMUM LIMIT (MHz)	PASS / FAIL
		CHAIN 0	CHAIN 1		
149	5745	17.64	17.64	0.5	PASS
157	5785	17.56	17.61	0.5	PASS
165	5825	17.66	17.63	0.5	PASS

### FOR CHAIN 0: CH 165

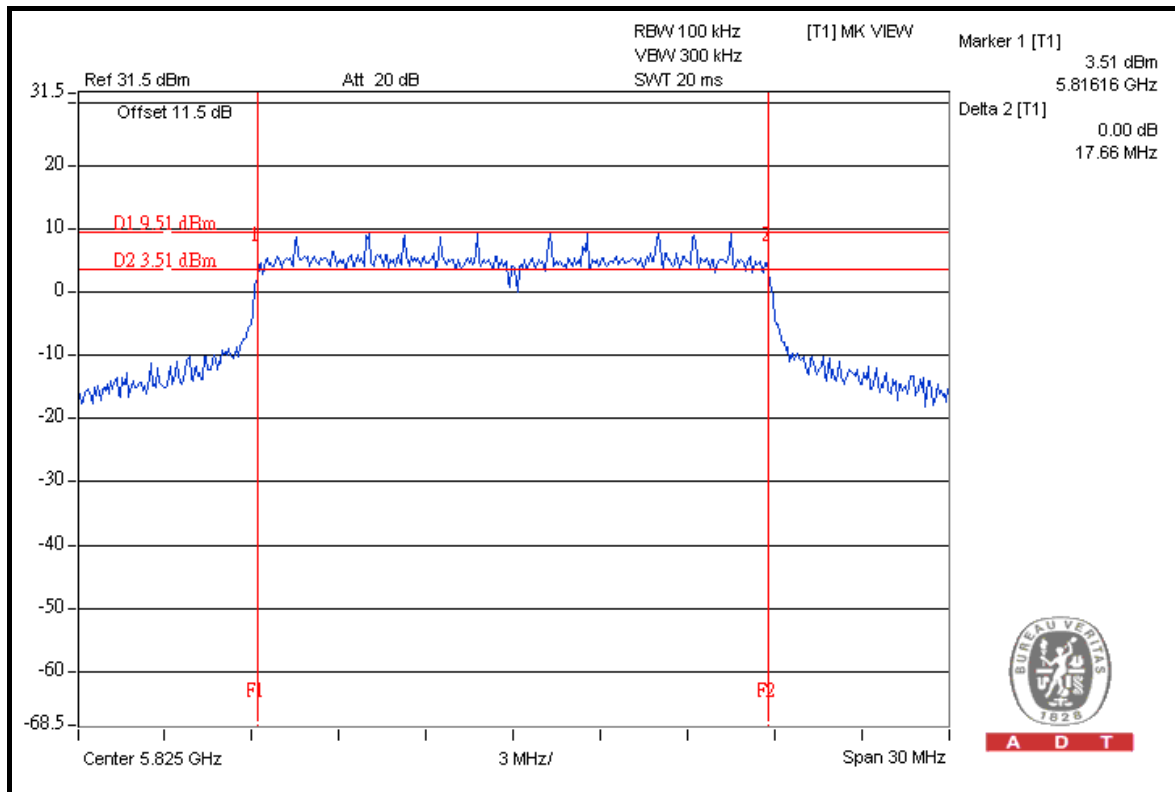



A D T

### 802.11n (40MHz)

CHANNEL	CHANNEL FREQUENCY (MHz)	6dB BANDWIDTH (MHz)		MINIMUM LIMIT (MHz)	PASS / FAIL
		CHAIN 0	CHAIN 1		
151	5755	36.43	36.12	0.5	PASS
159	5795	36.47	36.08	0.5	PASS

### FOR CHAIN 0: CH 159

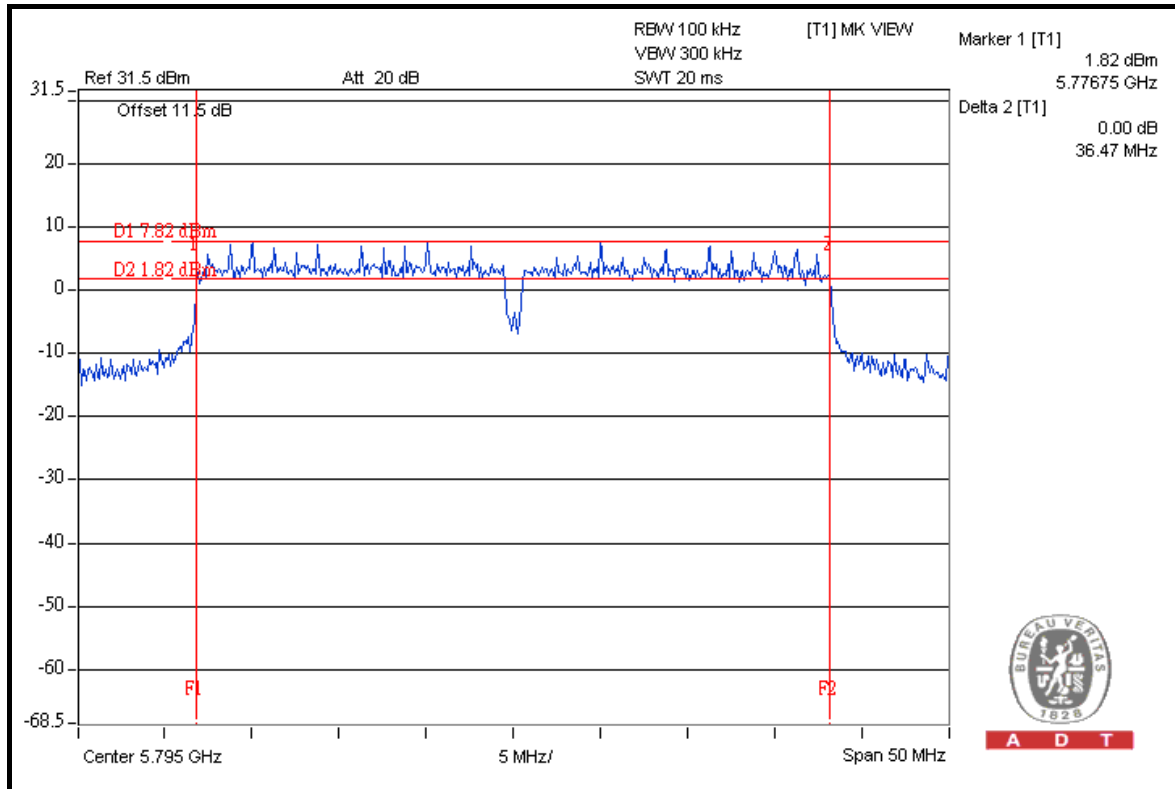



A D T

## 5.4 MAXIMUM OUTPUT POWER

### 5.4.1 LIMITS OF MAXIMUM OUTPUT POWER MEASUREMENT

The Maximum Peak Output Power Measurement is 30dBm.

### 5.4.2 INSTRUMENTS

DESCRIPTION & MANUFACTURER	MODEL NO.	SERIAL NO.	DATE OF CALIBRATION	DUE DATE OF CALIBRATION
High Speed Peak Power Meter	ML2495A	0842014	Apr. 21, 2010	Apr. 20, 2011
Power Sensor	MA2411B	0738404	Apr. 21, 2010	Apr. 20, 2011

**Note:**

1. The calibration interval of the above test instruments is 12 months and the calibrations are traceable to NML/ROC and NIST/USA.
2. Measurement Bandwidth of ML2495A is 65MHz greater than 6dB bandwidth of emission.

### 5.4.3 TEST PROCEDURES

A power sensor was used on the output port of the EUT. A power meter was used to read the response of the power sensor. Record the power level.

#### 5.4.4 DEVIATION FROM TEST STANDARD

No deviation

#### 5.4.5 TEST SETUP

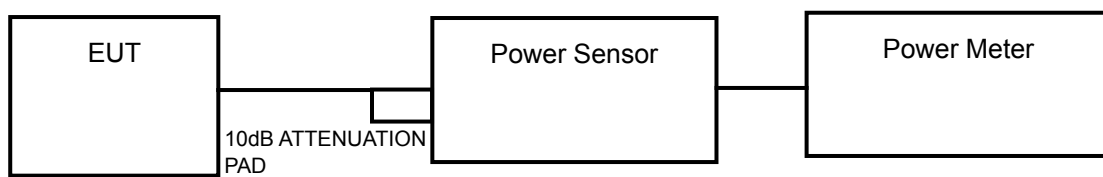

#### 5.4.6 EUT OPERATING CONDITIONS

Same as Item 5.3.6





## 5.4.7 TEST RESULTS

### 802.11a

CHAN.	CHAN. FREQ. (MHz)	POWER OUTPUT (dBm)		TOTAL POWER (mW)	TOTAL POWER (dBm)	POWER LIMIT (dBm)	PASS / FAIL
		CHAIN 0	CHAIN 1				
149	5745	25.2	23.1	535.3	27.3	27.82	PASS
157	5785	24.8	24.5	583.8	27.7	27.82	PASS
165	5825	24.8	24.1	559.0	27.5	27.82	PASS

\*\*Directional gain = 3.15dBi + 6.55dBi = 8.18dBi > 6dBi, conducted power limit is reduced from 30dBm down to  $30 - (8.18 - 6) = 27.82\text{dBm}$

### 802.11n (20MHz)

CHAN.	CHAN. FREQ. (MHz)	POWER OUTPUT (dBm)		TOTAL POWER (mW)	TOTAL POWER (dBm)	POWER LIMIT (dBm)	PASS / FAIL
		CHAIN 0	CHAIN 1				
149	5745	24.7	23.3	508.9	27.1	30	PASS
157	5785	25.0	23.8	556.1	27.5	30	PASS
165	5825	24.8	23.5	525.9	27.2	30	PASS

### 802.11n (40MHz)

CHAN.	CHAN. FREQ. (MHz)	POWER OUTPUT (dBm)		TOTAL POWER (mW)	TOTAL POWER (dBm)	POWER LIMIT (dBm)	PASS / FAIL
		CHAIN 0	CHAIN 1				
151	5755	25.3	23.4	557.6	27.5	30	PASS
159	5795	25.5	23.8	594.7	27.7	30	PASS



## 5.5 POWER SPECTRAL DENSITY MEASUREMENT

### 5.5.1 LIMITS OF POWER SPECTRAL DENSITY MEASUREMENT

The Maximum of Power Spectral Density Measurement is 8dBm.

### 5.5.2 TEST INSTRUMENTS

DESCRIPTION & MANUFACTURER	MODEL NO.	SERIAL NO.	DATE OF CALIBRATION	DUE DATE OF CALIBRATION
SPECTRUM ANALYZER R&S	FSP40	100039	Jan. 11, 2010	Jan. 10, 2011

**NOTE:** The calibration interval of the above test instruments is 12 months and the calibrations are traceable to NML/ROC and NIST/USA.

### 5.5.3 TEST PROCEDURE

The transmitter output was connected to the spectrum analyzer through an attenuator, the bandwidth of the fundamental frequency was measured with the spectrum analyzer using 3kHz RBW and 30kHz VBW, set sweep time = span/3kHz. The power spectral density was measured and recorded.

The sweep time is allowed to be longer than span/3kHz for a full response of the mixer in the spectrum analyzer.



A D T

#### 5.5.4 DEVIATION FROM TEST STANDARD

No deviation

#### 5.5.5 TEST SETUP

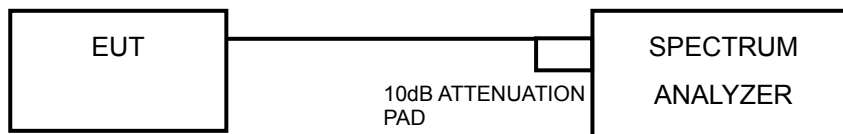

#### 5.5.6 EUT OPERATING CONDITION

Same as Item 5.3.6



A D T

### 5.5.7 TEST RESULTS

#### 802.11a

CHAN.	CHAN. FREQ. (MHz)	RF POWER LEVEL IN 3kHz BW (dBm)		TOTAL POWER DENSITY (dBm)	MAX. LIMIT (dBm)	PASS / FAIL
		CHAIN 0	CHAIN 1			
149	5745	-4.6	-6.0	-2.2	5.82	PASS
157	5785	-3.8	-3.4	-0.6	5.82	PASS
165	5825	-5.0	-4.8	-1.9	5.82	PASS

\*\*Directional gain = 3.15dBi + 6.55dBi = 8.18dBi > 6dBi, Power Density limit is reduced from 8dBm down to  $8 - (8.18 - 6) = 5.82$ dBm

#### FOR CHAIN 1: CH 157

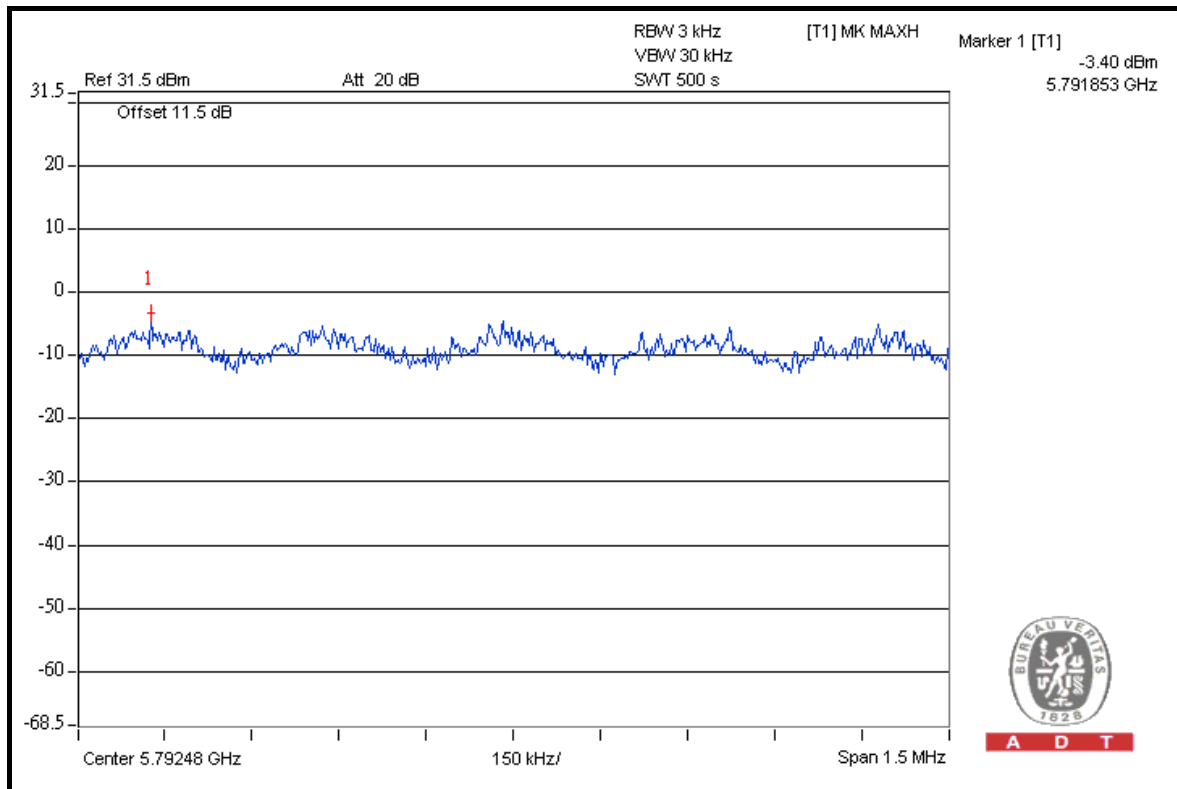

A D T



A D T

### 802.11n (20MHz)

CHAN.	CHAN. FREQ. (MHz)	RF POWER LEVEL IN 3kHz BW (dBm)		TOTAL POWER DENSITY (dBm)	MAX. LIMIT (dBm)	PASS / FAIL
		CHAIN 0	CHAIN 1			
149	5745	-5.6	-5.6	-2.6	8	PASS
157	5785	-5.4	-4.9	-2.1	8	PASS
165	5825	-5.3	-5.5	-2.4	8	PASS

### FOR CHAIN 1: CH 157

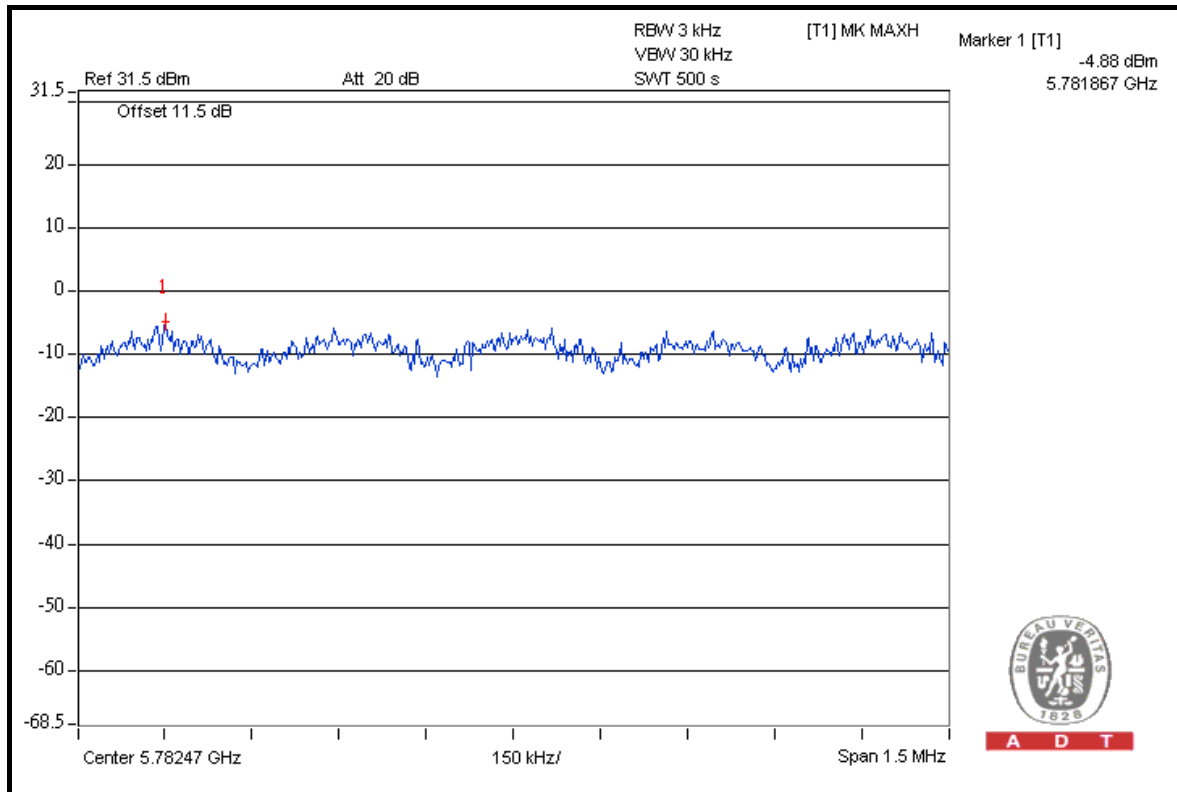



A D T

### 802.11n (40MHz)

CHAN.	CHAN. FREQ. (MHz)	RF POWER LEVEL IN 3kHz BW (dBm)		TOTAL POWER DENSITY (dBm)	MAX. LIMIT (dBm)	PASS / FAIL
		CHAIN 0	CHAIN 1			
151	5755	-6.6	-8.1	-4.3	8	PASS
159	5795	-6.5	-7.5	-4.0	8	PASS

### FOR CHAIN 0: CH 159

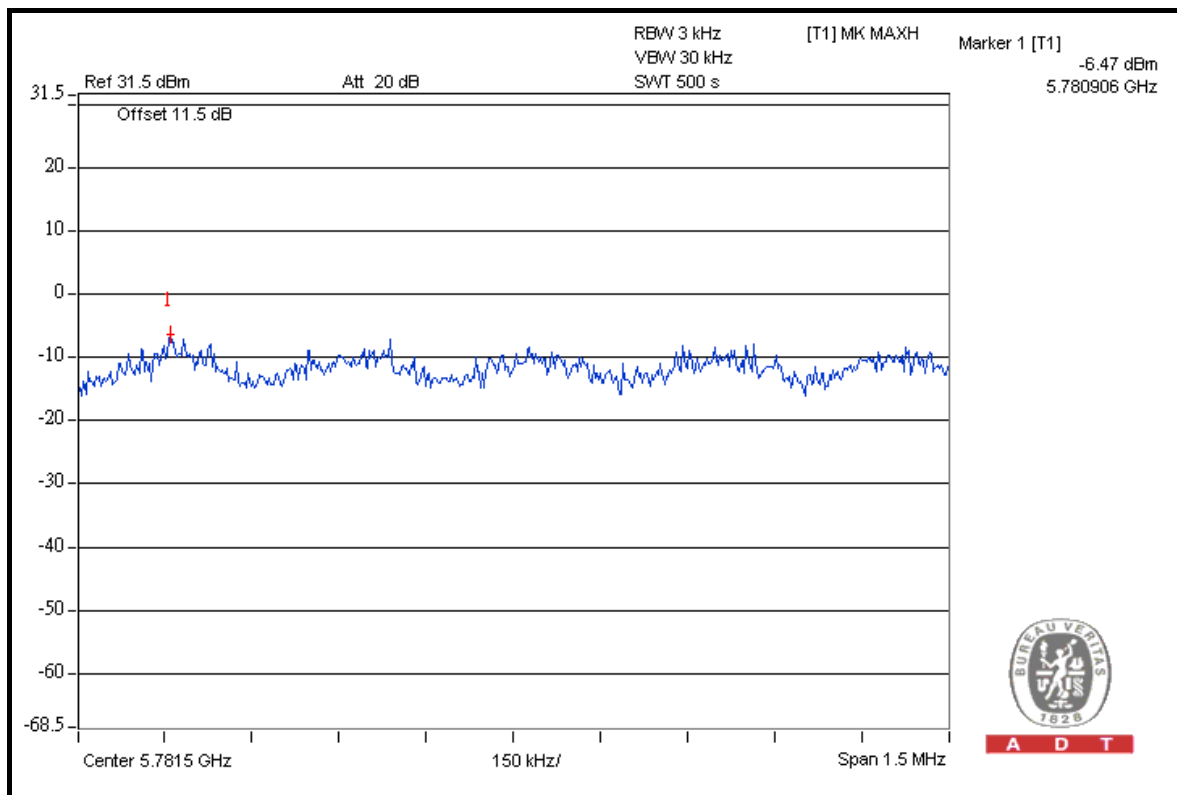

## 5.6 BAND EDGES MEASUREMENT

### 5.6.1 LIMITS OF BAND EDGES MEASUREMENT

Below -20dB of the highest emission level of operating band (in 100kHz Resolution Bandwidth).

### 5.6.2 TEST INSTRUMENTS

DESCRIPTION & MANUFACTURER	MODEL NO.	SERIAL NO.	DATE OF CALIBRATION	CALIBRATED UNTIL
Test Receiver ROHDE & SCHWARZ	ESI7	838496/016	Dec. 29, 2009	Dec. 28, 2010
Spectrum Analyzer ROHDE & SCHWARZ	FSP40	100039	Jan. 11, 2010	Jan. 10, 2011
BILOG Antenna SCHWARZBECK	VULB9168	9168-155	Apr. 28, 2010	Apr. 27, 2011
HORN Antenna SCHWARZBECK	BBHA 9120D	9120D-408	Jan. 05, 2010	Jan. 04, 2011
HORN Antenna SCHWARZBECK	BBHA 9170	BBHA9170242	Dec. 25, 2009	Dec. 24, 2010
Preamplifier Agilent	8449B	3008A01961	Nov. 04, 2009	Nov. 03, 2010
Preamplifier Agilent	8447D	2944A10738	Nov. 04, 2009	Nov. 03, 2010
RF signal cable HUBER+SUHNNER	SUCOFLEX 104	238141/4	May 14, 2010	May 13, 2011
RF signal cable HUBER+SUHNNER	SUCOFLEX 104	12738/6	May 14, 2010	May 13, 2011
Software ADT.	ADT_Radiated_ V7.6.15.9.2	NA	NA	NA
Antenna Tower inn-co GmbH	MA 4000	010303	NA	NA
Antenna Tower Controller inn-co GmbH	CO2000	019303	NA	NA
Turn Table ADT.	TT100.	TT93021704	NA	NA
Turn Table Controller ADT.	SC100.	SC93021704	NA	NA
26GHz ~ 40GHz Amplifier	EM26400	07026401	Jul. 02, 2010	Jul. 01, 2011

**NOTE:** The calibration interval of the above test instruments is 12 months and the calibrations are traceable to NML/ROC and NIST/USA.



### 5.6.3 TEST PROCEDURE

- a. The EUT was placed on the top of a rotating table 0.8 meters above the ground at a 3 meter semi-anechoic chamber. The table was rotated 360 degrees to determine the position of the highest radiation.
- b. The EUT was set 3 meters away from the interference-receiving antenna, which was mounted on the top of a variable-height antenna tower.
- c. The antenna is a broadband antenna, and its height is varied from one meter to four meters above the ground to determine the maximum value of the field strength. Both horizontal and vertical polarizations of the antenna are set to make the measurement.
- d. For each suspected emission, the EUT was arranged to its worst case and then the antenna was tuned to heights from 1 meter to 4 meters and the rotatable table was turned from 0 degrees to 360 degrees to find the maximum reading.
- e. Set both RBW and VBW of spectrum analyzer to 100kHz and 300kHz with suitable frequency span including 100MHz bandwidth from band edge. The band edges was measured and recorded.

**NOTE:** The resolution bandwidth of test receiver/spectrum analyzer is 1MHz and the video bandwidth is 10Hz for Average detection (AV) at frequency above 1GHz.





A D T

#### 5.6.4 DEVIATION FROM TEST STANDARD

No deviation

#### 5.6.5 EUT OPERATING CONDITION

Same as Item 5.3.6

#### 5.6.6 TEST RESULTS

The spectrum plots are attached on the following pages. D1 line indicates the highest level, D2 line indicates the 20dB offset below D1. It shows compliance with the requirement in part 15.247(d).



A D T

### 802.11a

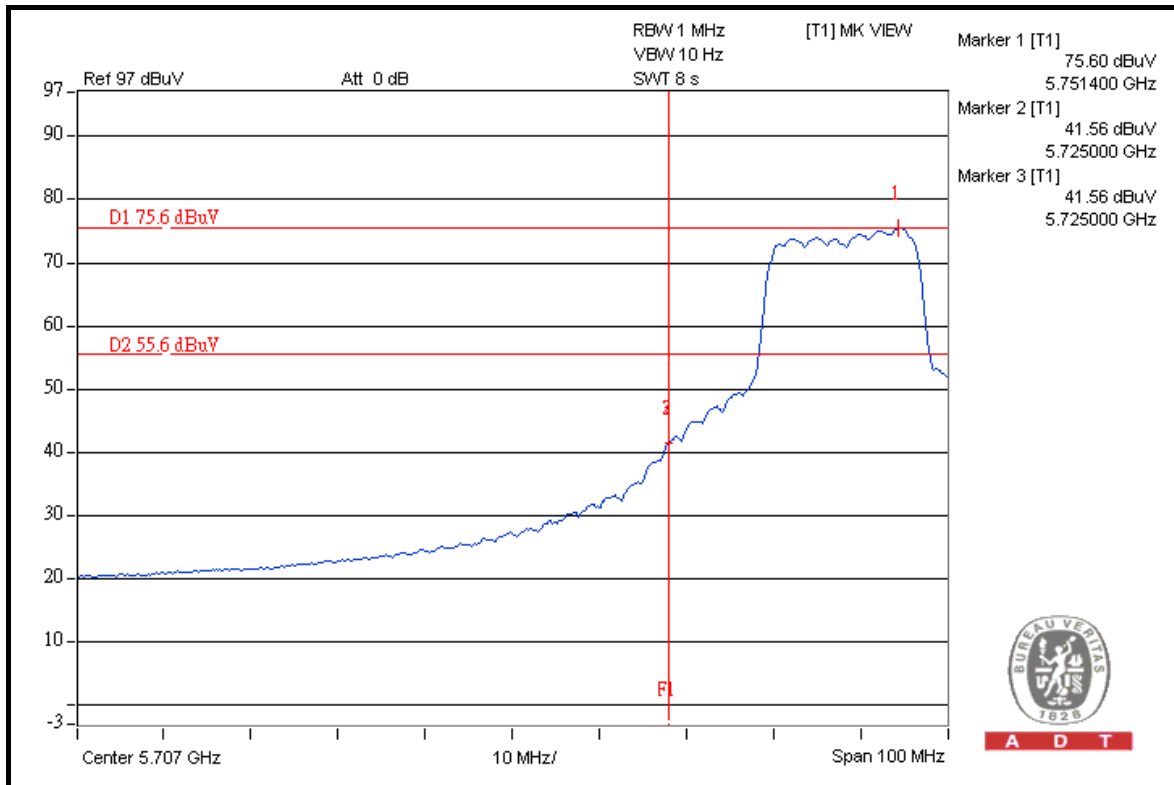
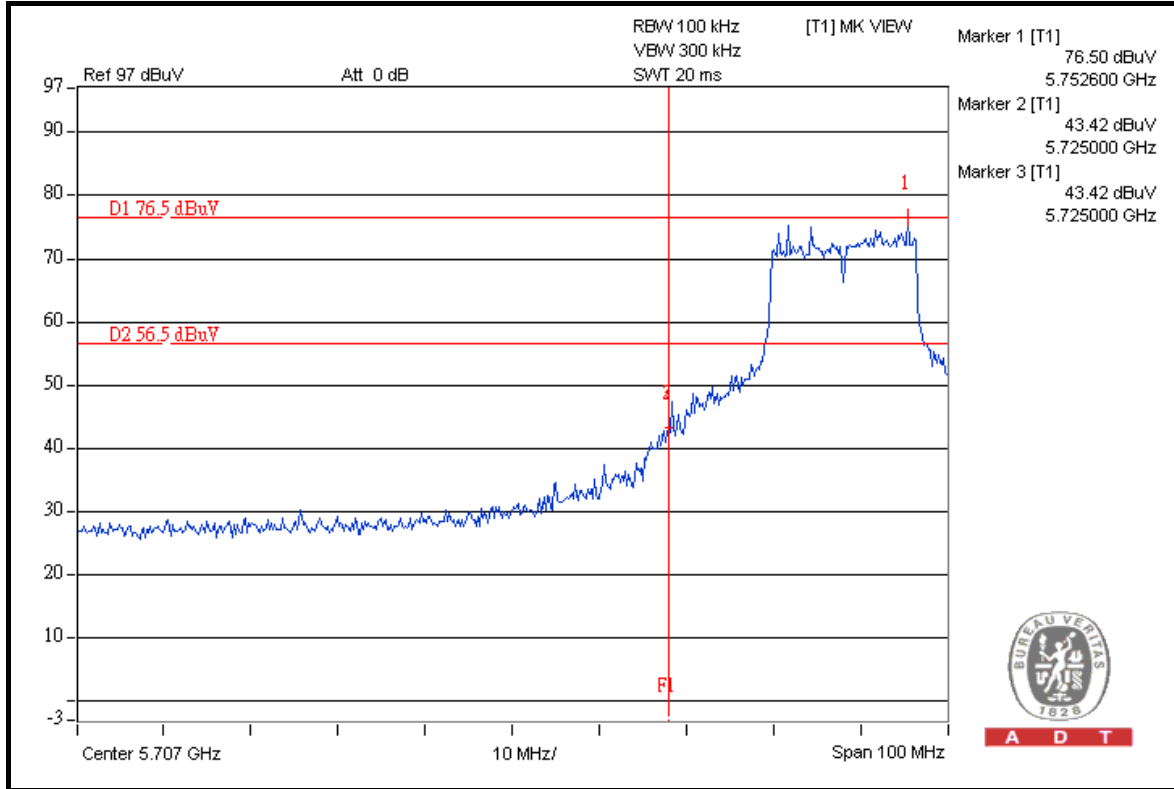



A D T

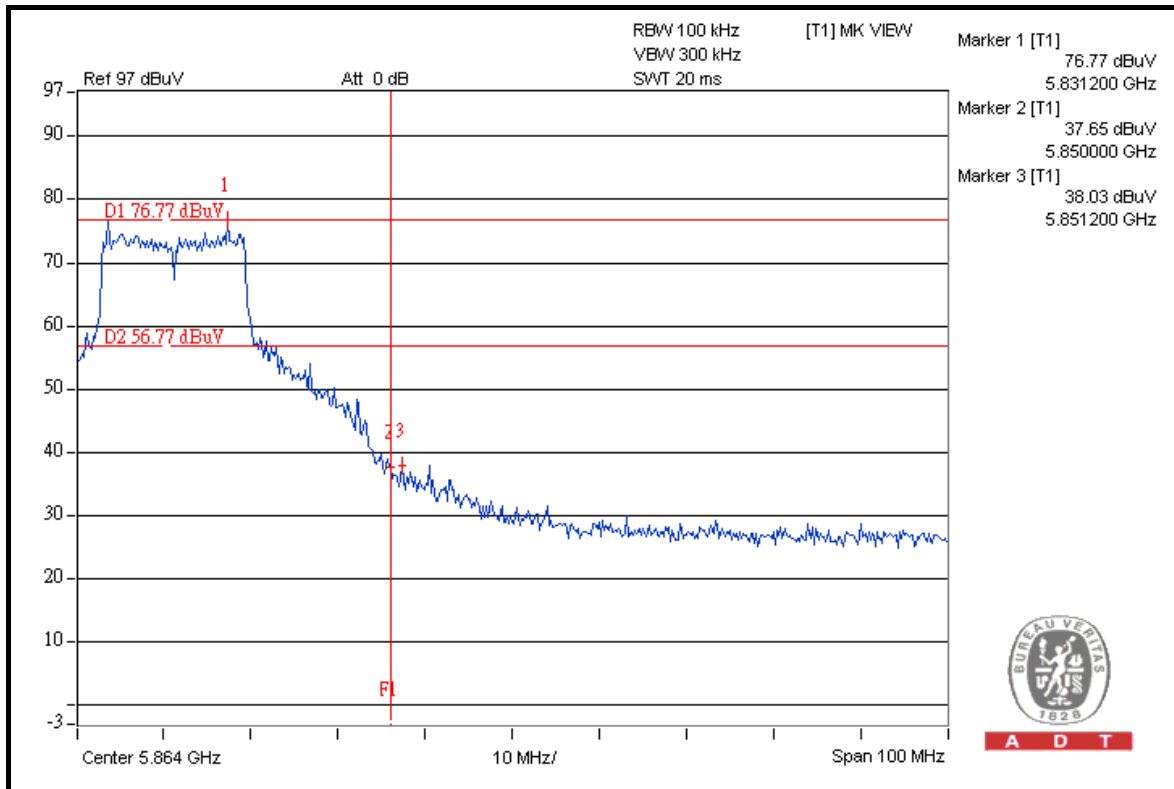
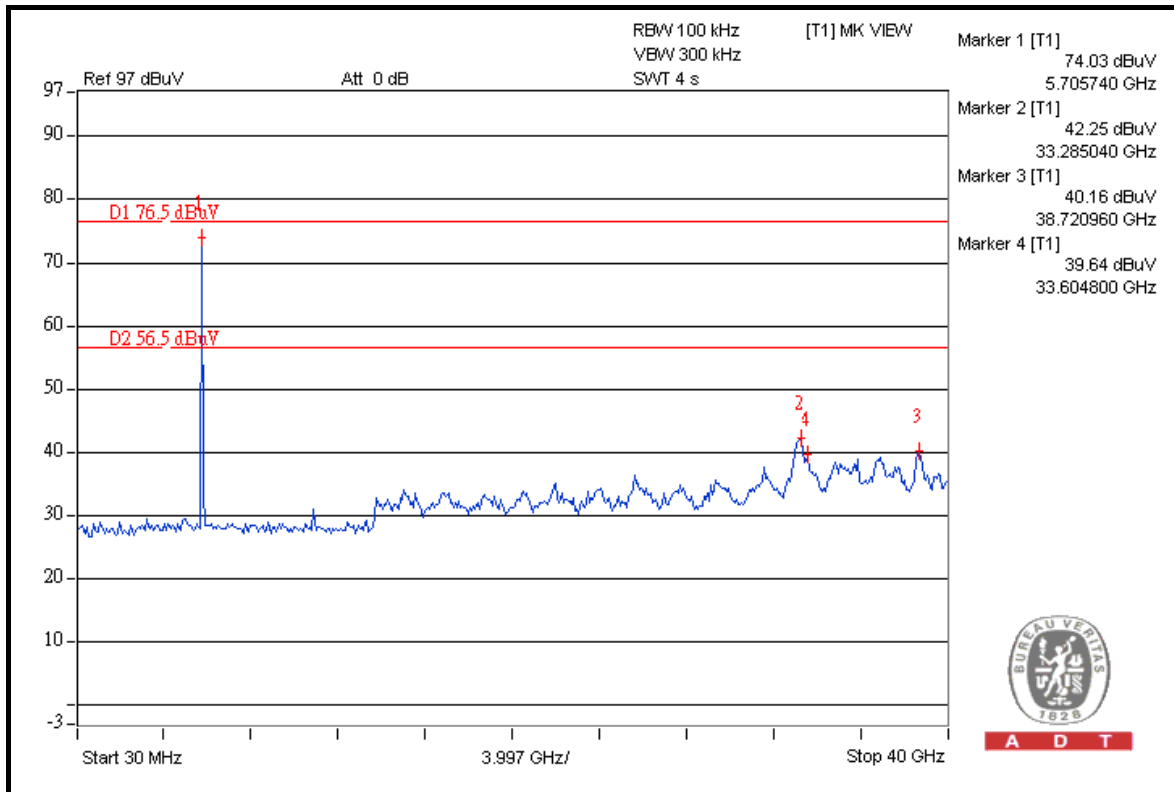



A D T

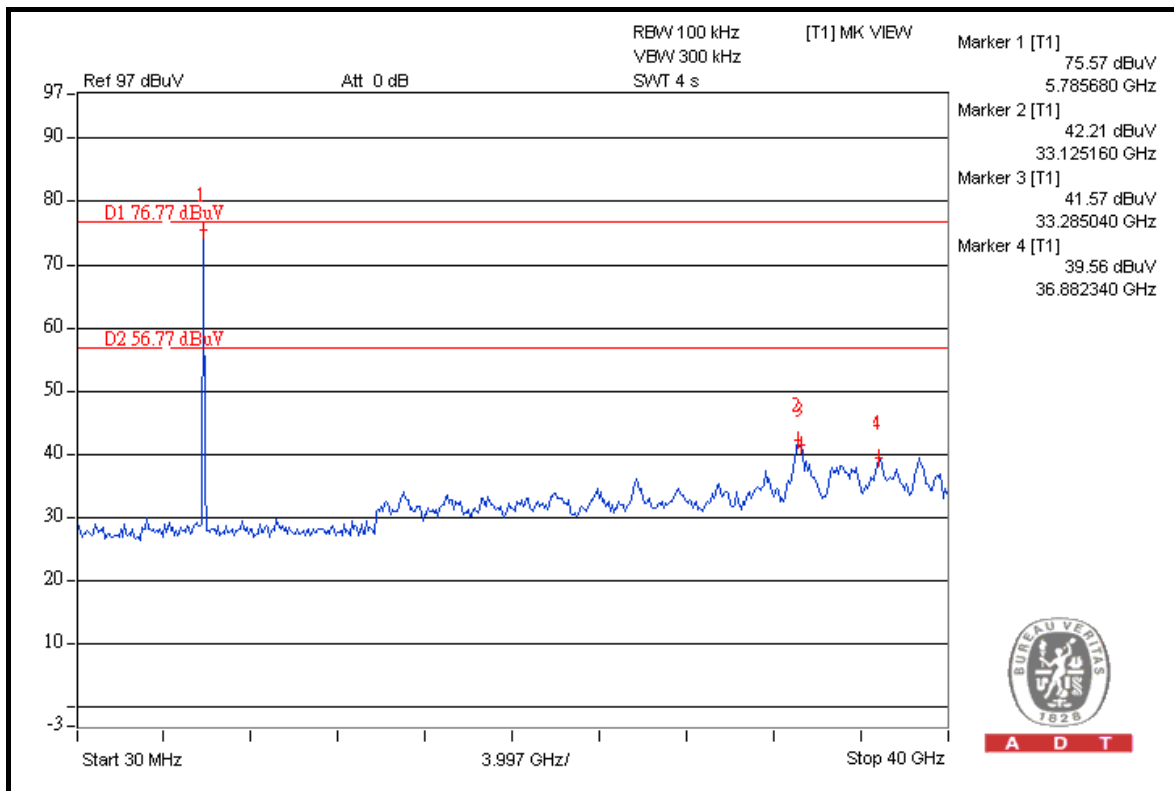
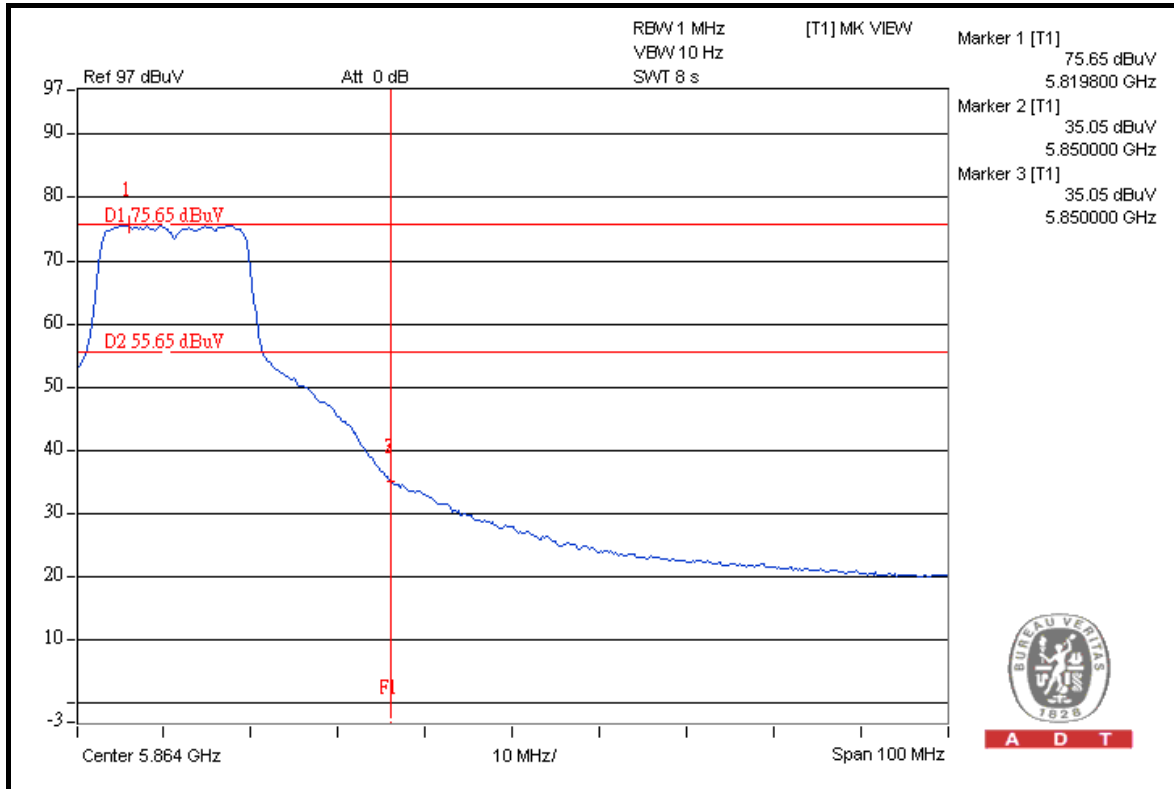



A D T

### 802.11n (20MHz)

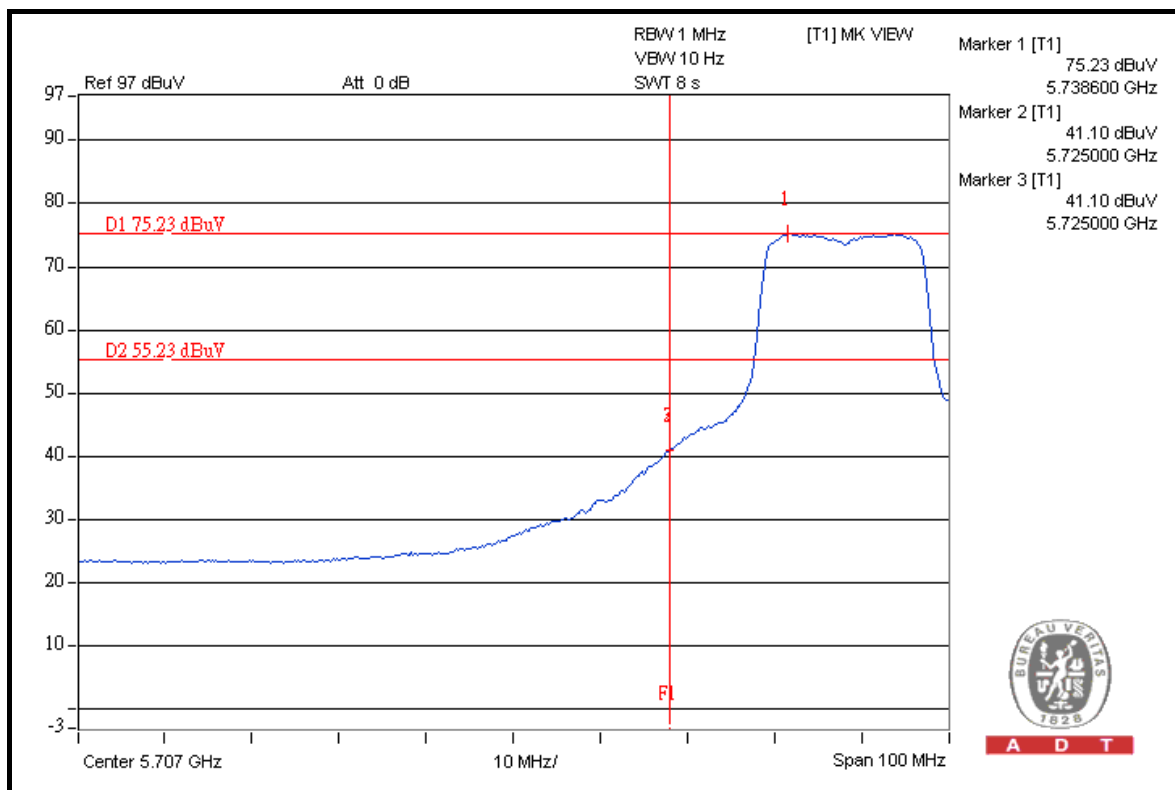
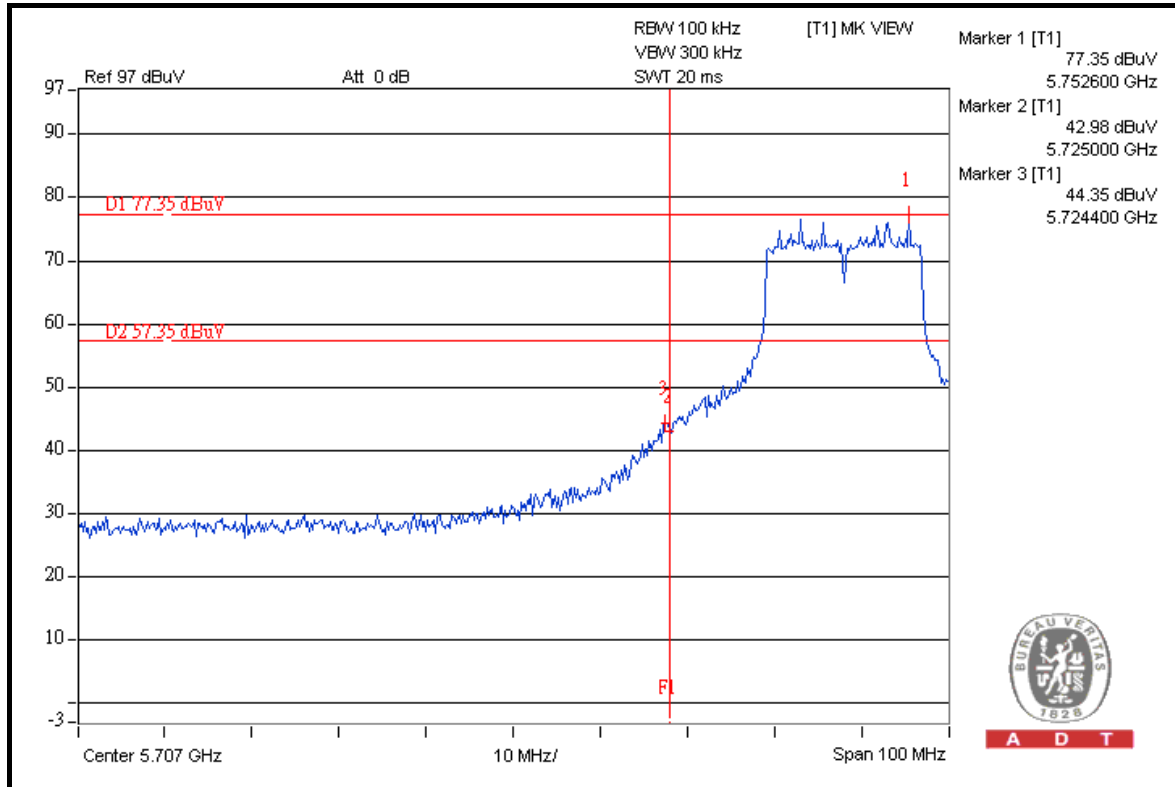



A D T

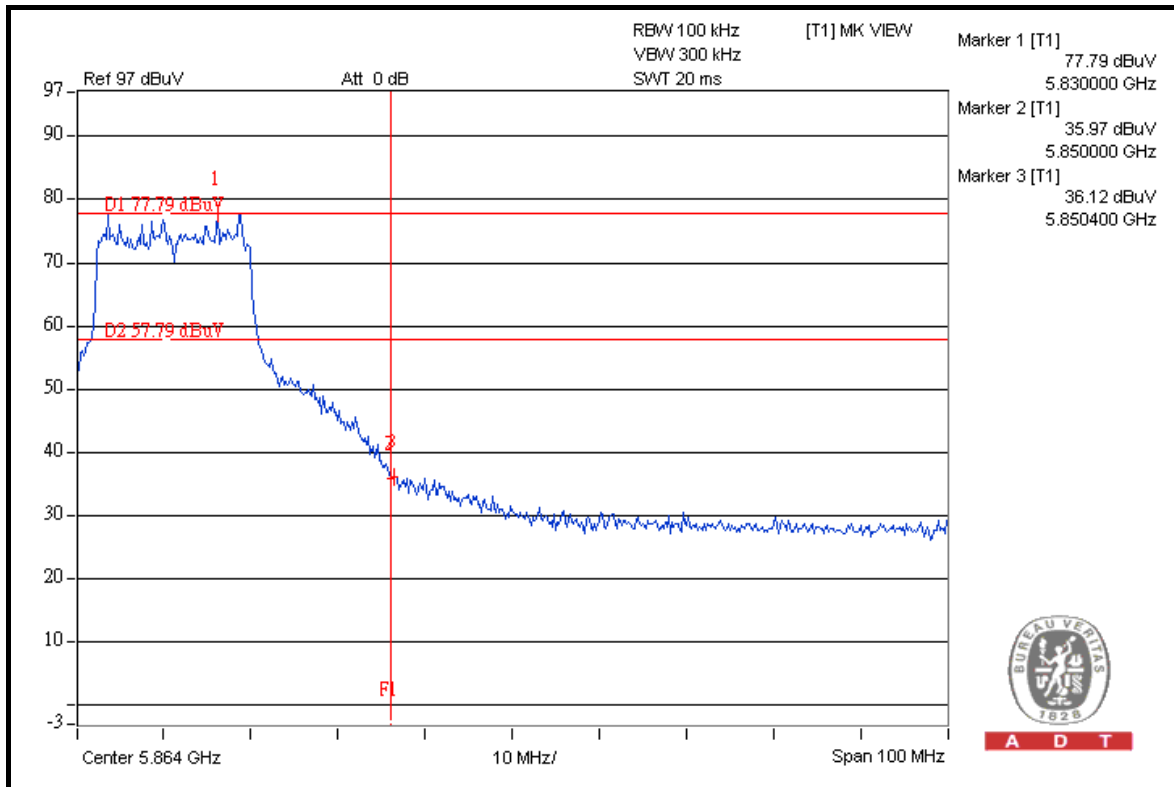
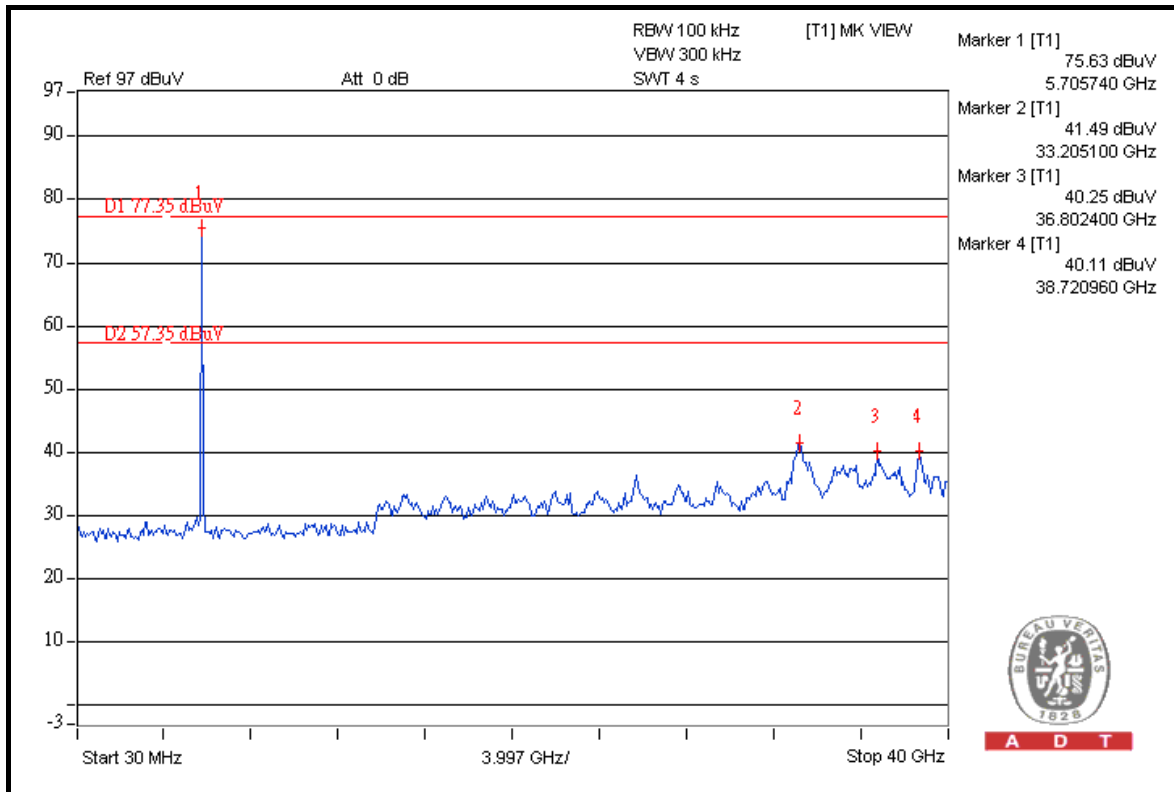



A D T

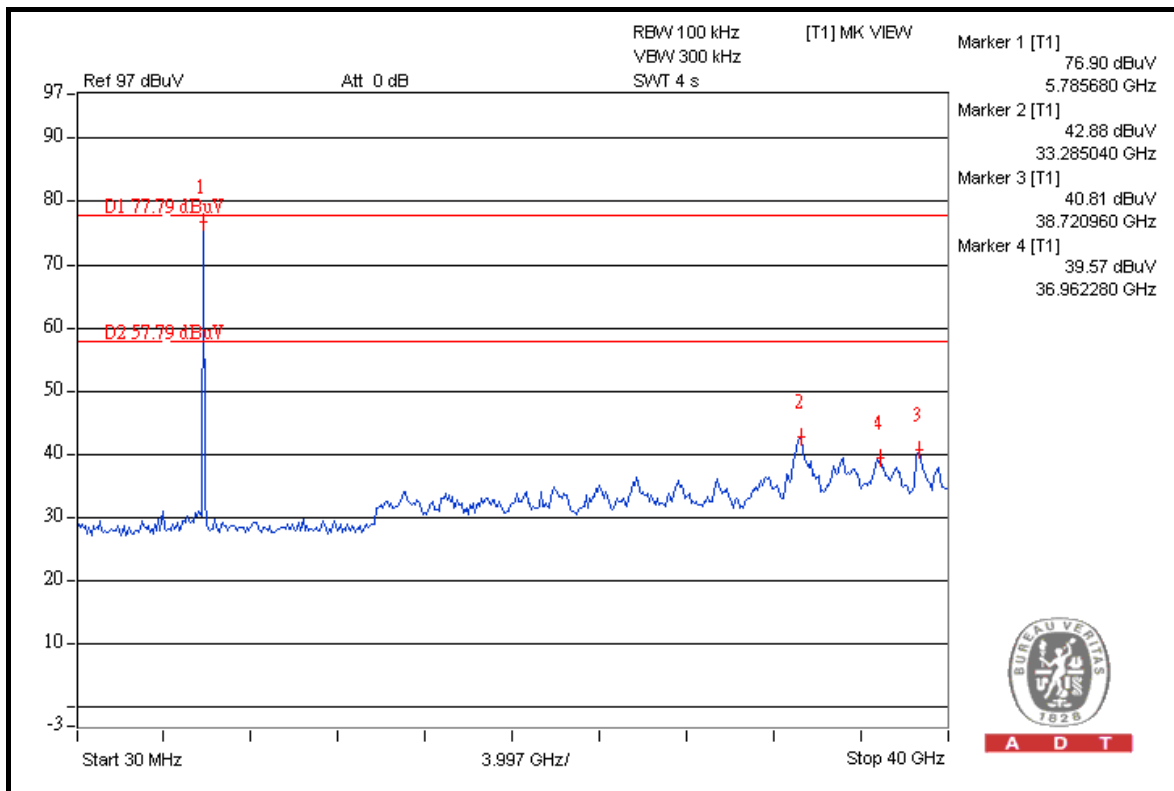
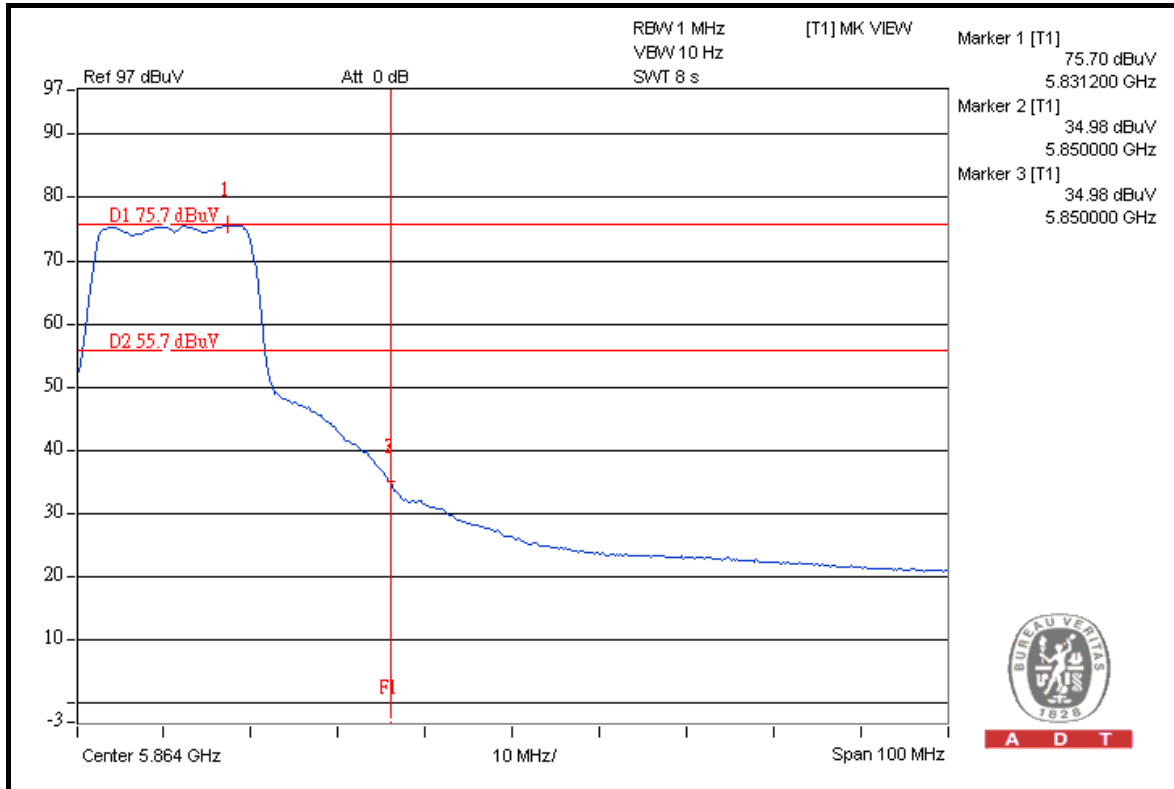



A D T

### 802.11n (40MHz)

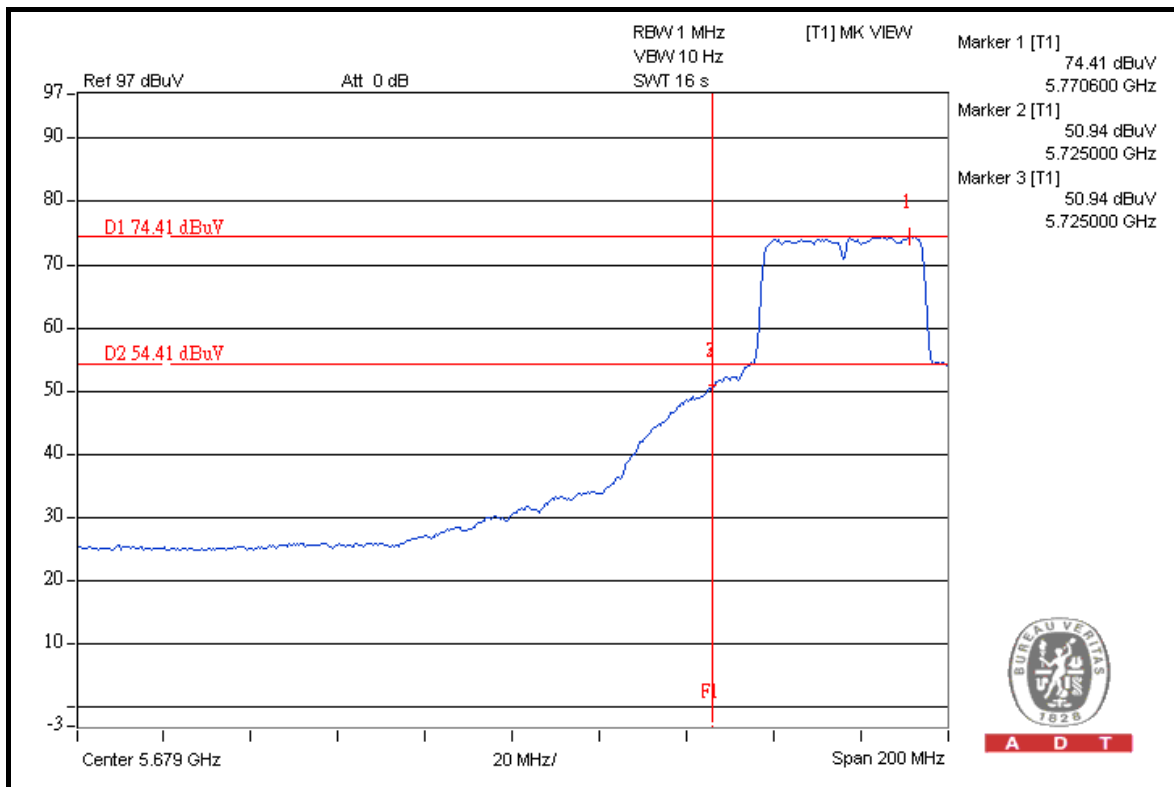
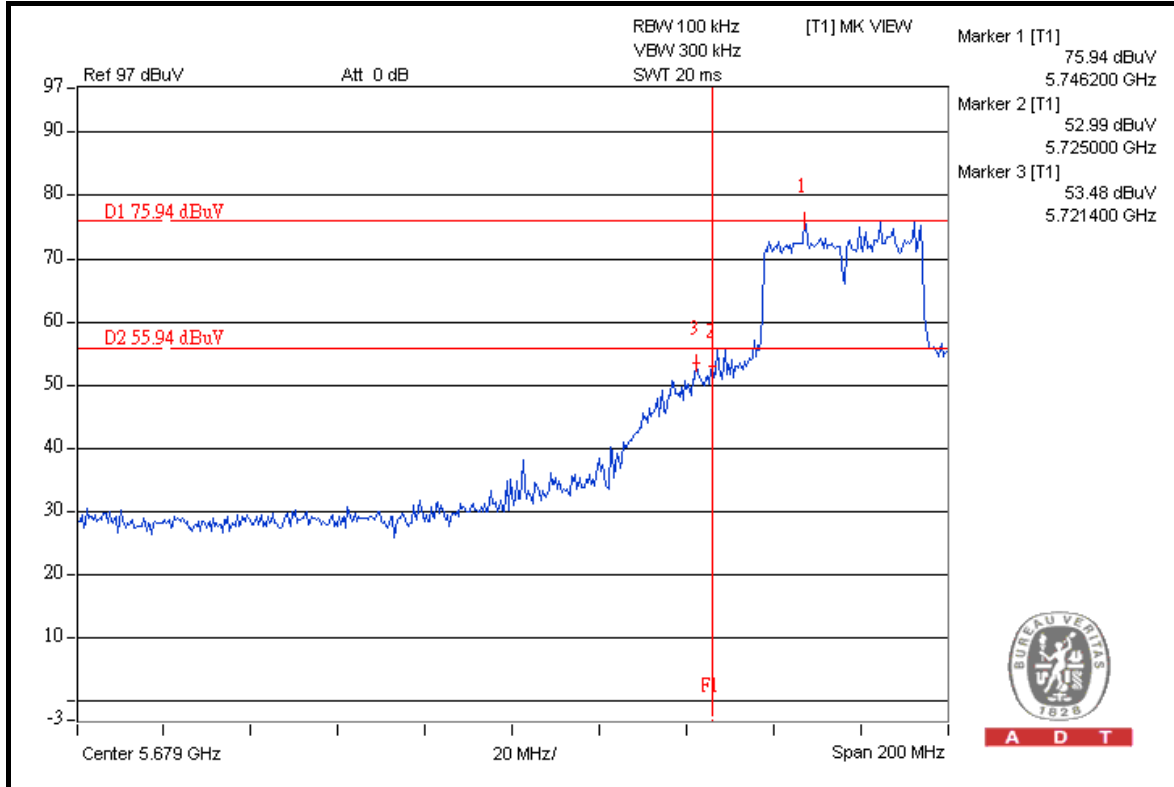





A D T

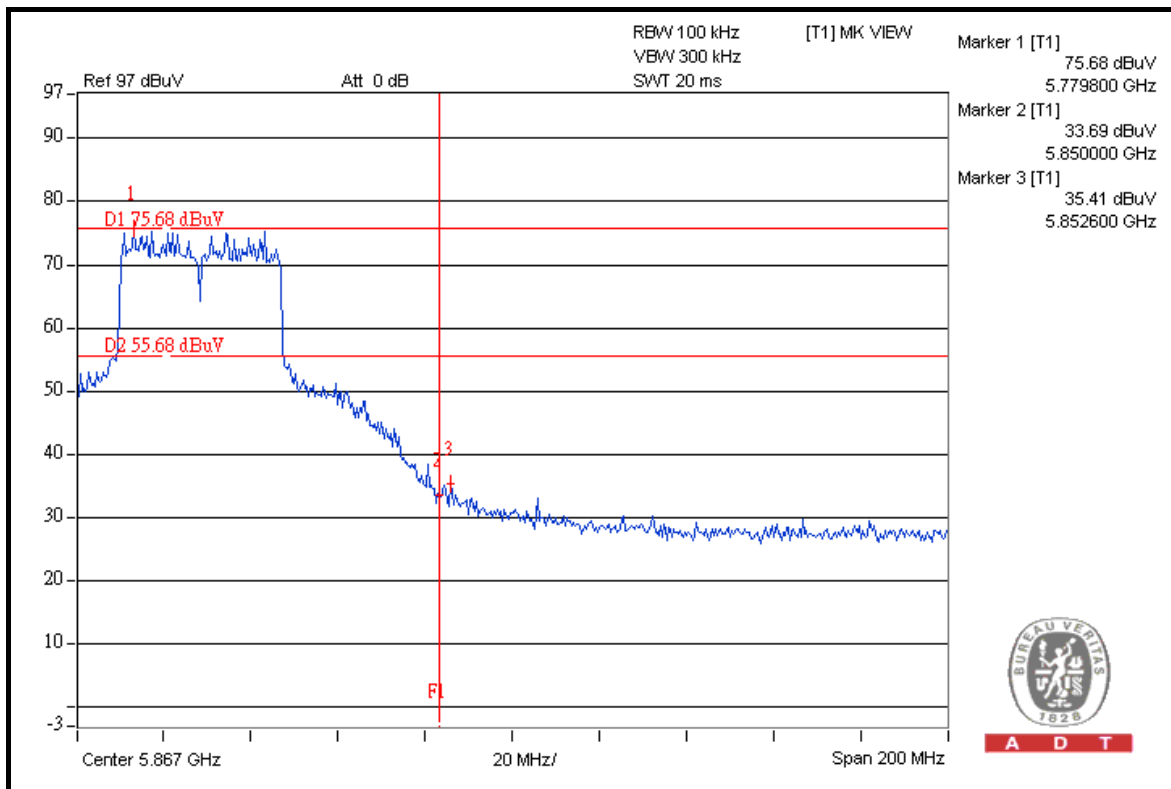
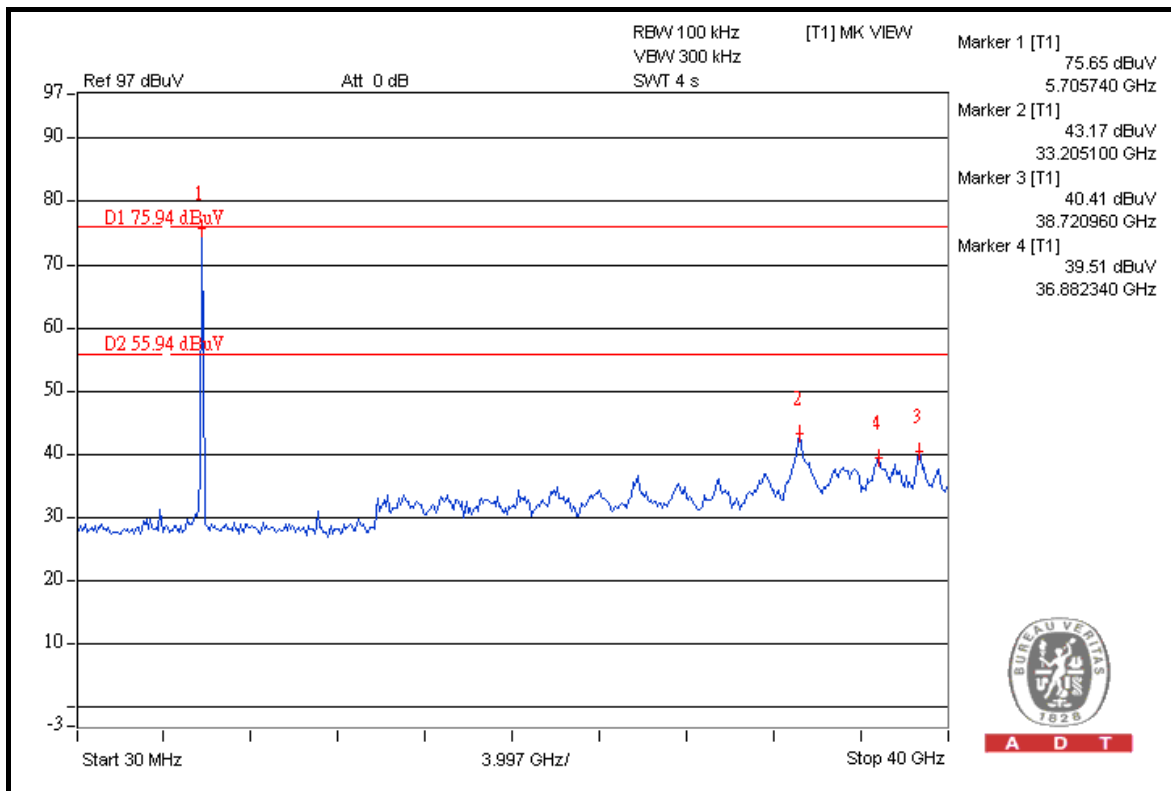



A D T

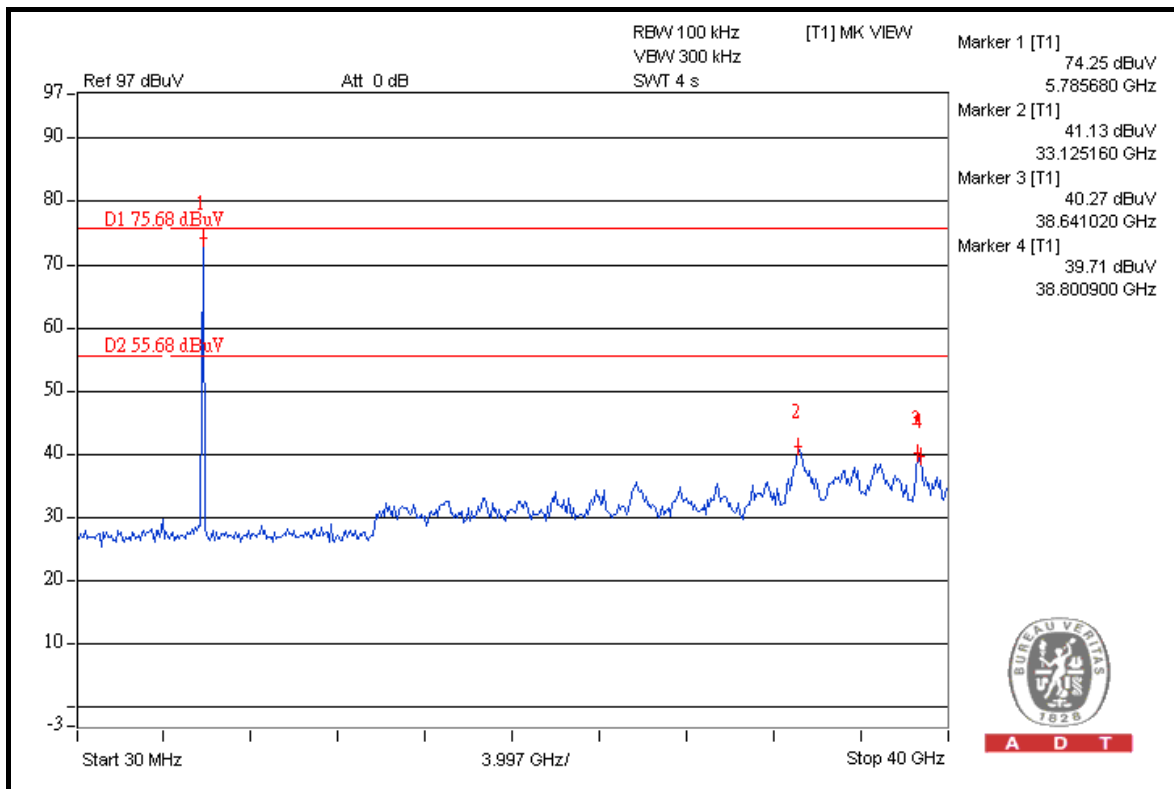
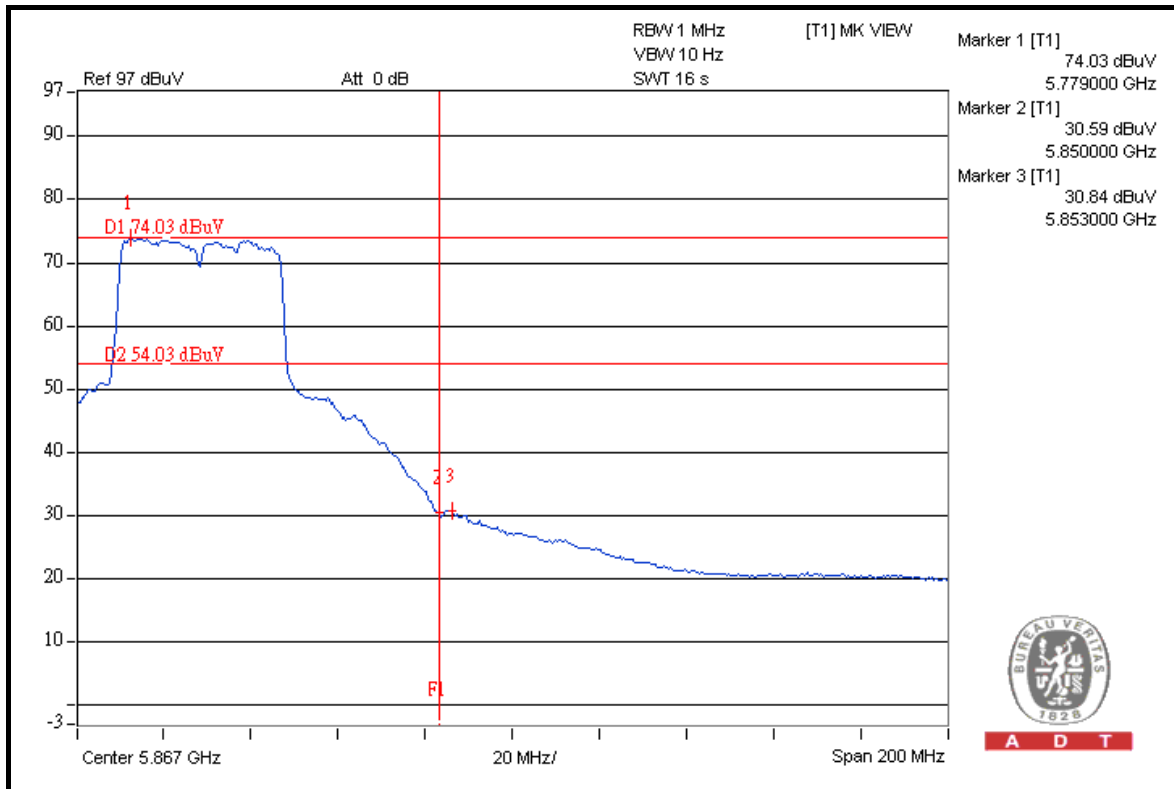



A D T

## 6. PHOTOGRAPHS OF THE TEST CONFIGURATION

Please refer to the attached file (Test Setup Photo).



A D T

## 7. INFORMATION ON THE TESTING LABORATORIES

We, Bureau Veritas Consumer Products Services (H.K.) Ltd., Taoyuan Branch, were founded in 1988 to provide our best service in EMC, Radio, Telecom and Safety consultation. Our laboratories are accredited and approved according to ISO/IEC 17025.

Copies of accreditation certificates of our laboratories obtained from approval agencies can be downloaded from our web site:

[www.adt.com.tw/index.5/phtml](http://www.adt.com.tw/index.5/phtml). If you have any comments, please feel free to contact us at the following:

**Linko EMC/RF Lab:**

Tel: 886-2-26052180

Fax: 886-2-26051924

**Hsin Chu EMC/RF Lab:**

Tel: 886-3-5935343

Fax: 886-3-5935342

**Hwa Ya EMC/RF/Safety Telecom Lab:**

Tel: 886-3-3183232

Fax: 886-3-3185050

**Web Site:** [www.adt.com.tw](http://www.adt.com.tw)

The address and road map of all our labs can be found in our web site also.



A D T

## **8. APPENDIX A - MODIFICATIONS RECORDERS FOR ENGINEERING CHANGES TO THE EUT BY THE LAB**

No any modifications are made to the EUT by the lab during the test.

**---END---**