

FCC Test Report

Report No.: RF161004C24

FCC ID: TVE-140701

Test Model: FAP-221E, FAP-223E (refer to item 3.1 for more details)

Series Model: FortiAP 221Exxxxx, FAP-221Exxxxx, FORTIAP-221Exxxxx, FortiAP 223Exxxxx, FAP-223Exxxxx, FORTIAP-223Exxxxx (where "x" can be used as "A-Z", or "0-9", or "-", or blank for marketing purposes only) (refer to item 3.1 for more details)

Received Date: Oct. 04, 2016

Test Date: Oct. 12, 2016 ~ Jan. 18, 2017

Issued Date: Feb. 07, 2017

Applicant: Fortinet Inc.

Address: 899 Kifer Road Sunnyvale, CA 94086 USA

Issued By: Bureau Veritas Consumer Products Services (H.K.) Ltd., Taoyuan Branch

Lab Address: No. 47-2, 14th Ling, Chia Pau Vil., Lin Kou Dist., New Taipei City, Taiwan, R.O.C.

Test Location: No.19, Hwa Ya 2nd Rd., Wen Hwa Vil., Kwei Shan Dist., Taoyuan City 33383, TAIWAN (R.O.C.)



This report is for your exclusive use. Any copying or replication of this report to or for any other person or entity, or use of our name or trademark, is permitted only with our prior written permission. This report sets forth our findings solely with respect to the test samples identified herein. The results set forth in this report are not indicative or representative of the quality or characteristics of the lot from which a test sample was taken or any similar or identical product unless specifically and expressly noted. Our report includes all of the tests requested by you and the results thereof based upon the information that you provided to us. You have 60 days from date of issuance of this report to notify us of any material error or omission caused by our negligence, provided, however, that such notice shall be in writing and shall specifically address the issue you wish to raise. A failure to raise such issue within the prescribed time shall constitute your unqualified acceptance of the completeness of this report, the tests conducted and the correctness of the report contents. Unless specific mention, the uncertainty of measurement has been explicitly taken into account to declare the compliance or non-compliance to the specification. This report should not be used by the client to claim product certification, approval, or endorsement by TAF or any government agencies.

Table of Contents

Release Control Record	4
1 Certificate of Conformity	5
2 Summary of Test Results	6
2.1 Measurement Uncertainty.....	6
2.2 Modification Record.....	6
3 General Information	7
3.1 General Description of EUT.....	7
3.2 Description of Test Modes.....	9
3.2.1 Test Mode Applicability and Tested Channel Detail.....	10
3.3 Duty Cycle of Test Signal.....	12
3.4 Description of Support Units.....	13
3.4.1 Configuration of System under Test.....	14
3.5 General Description of Applied Standards.....	15
4 Test Types and Results	16
4.1 Radiated Emission and Bandedge Measurement.....	16
4.1.1 Limits of Radiated Emission and Bandedge Measurement.....	16
4.1.2 Test Instruments.....	17
4.1.3 Test Procedures.....	18
4.1.4 Deviation from Test Standard.....	18
4.1.5 Test Set Up.....	19
4.1.6 EUT Operating Conditions.....	20
4.1.7 Test Results.....	21
4.2 Conducted Emission Measurement.....	49
4.2.1 Limits of Conducted Emission Measurement.....	49
4.2.2 Test Instruments.....	49
4.2.3 Test Procedures.....	50
4.2.4 Deviation from Test Standard.....	50
4.2.5 Test Setup.....	50
4.2.6 EUT Operating Conditions.....	50
4.2.7 Test Results.....	51
4.3 6dB Bandwidth Measurement.....	59
4.3.1 Limits of 6dB Bandwidth Measurement.....	59
4.3.2 Test Setup.....	59
4.3.3 Test Instruments.....	59
4.3.4 Test Procedure.....	59
4.3.5 Deviation from Test Standard.....	59
4.3.6 EUT Operating Conditions.....	59
4.3.7 Test Result.....	60
4.4 Conducted Output Power Measurement.....	62
4.4.1 Limits of Conducted Output Power Measurement.....	62
4.4.2 Test Setup.....	62
4.4.3 Test Instruments.....	62
4.4.4 Test Procedures.....	62
4.4.5 Deviation from Test Standard.....	62
4.4.6 EUT Operating Conditions.....	62
4.4.7 Test Results.....	63
4.5 Power Spectral Density Measurement.....	65
4.5.1 Limits of Power Spectral Density Measurement.....	65
4.5.2 Test Setup.....	65
4.5.3 Test Instruments.....	65
4.5.4 Test Procedure.....	65
4.5.5 Deviation from Test Standard.....	66
4.5.6 EUT Operating Condition.....	66

4.5.7 Test Results	67
4.6 Conducted Out of Band Emission Measurement.....	70
4.6.1 Limits of Conducted Out of Band Emission Measurement	70
4.6.2 Test Setup.....	70
4.6.3 Test Instruments	70
4.6.4 Test Procedure	70
4.6.5 Deviation from Test Standard	71
4.6.6 EUT Operating Condition	71
4.6.7 Test Results	71
5 Pictures of Test Arrangements.....	80
Appendix – Information on the Testing Laboratories	81

Release Control Record

Issue No.	Description	Date Issued
RF161004C24	Original release	Feb. 07, 2017

1 Certificate of Conformity

Product: Secured Wireless Access Point

Brand: Fortinet Inc.

Test Model: FAP-221E, FAP-223E (refer to item 3.1 for more details)

Series Model: FortiAP 221Exxxxx, FAP-221Exxxxx, FORTIAP-221Exxxxx, FortiAP 223Exxxxx, FAP-223Exxxxx, FORTIAP-223Exxxxx (where "x" can be used as "A-Z", or "0-9", or "-", or blank for marketing purposes only) (refer to item 3.1 for more details)

Sample Status: Engineering sample

Applicant: Fortinet Inc.

Test Date: Oct. 12, 2016 ~ Jan. 18, 2017

Standards: 47 CFR FCC Part 15, Subpart C (Section 15.247)
ANSI C63.10:2013

The above equipment has been tested by **Bureau Veritas Consumer Products Services (H.K.) Ltd., Taoyuan Branch**, and found compliance with the requirement of the above standards. The test record, data evaluation & Equipment Under Test (EUT) configurations represented herein are true and accurate accounts of the measurements of the sample's EMC characteristics under the conditions specified in this report.

Prepared by : Celine Chou , **Date:** Feb. 07, 2017
Celine Chou / Specialist

Approved by : Ken Liu , **Date:** Feb. 07, 2017
Ken Liu / Senior Manager

2 Summary of Test Results

47 CFR FCC Part 15, Subpart C (Section 15.247)			
FCC Clause	Test Item	Result	Remarks
15.207	AC Power Conducted Emission	Pass	Meet the requirement of limit. Minimum passing margin is -3.01dB at 0.53281MHz
15.205 / 15.209 / 15.247(d)	Radiated Emissions and Band Edge Measurement	Pass	Meet the requirement of limit. Minimum passing margin is -1.0dB at 2483.50MHz.
15.247(d)	Antenna Port Emission	Pass	Meet the requirement of limit.
15.247(a)(2)	6dB bandwidth	Pass	Meet the requirement of limit.
15.247(b)	Conducted power	Pass	Meet the requirement of limit.
15.247(e)	Power Spectral Density	Pass	Meet the requirement of limit.
15.203	Antenna Requirement	Pass	For printed antenna Antenna connector is IPEX not a standard connector. For dipole antenna Antenna connector is RP SMA plug not a standard connector.

2.1 Measurement Uncertainty

Where relevant, the following measurement uncertainty levels have been estimated for tests performed on the EUT as specified in CISPR 16-4-2:

Measurement	Frequency	Expanded Uncertainty (k=2) (\pm)
Conducted Emissions at mains ports	150kHz ~ 30MHz	2.44 dB
Radiated Emissions up to 1 GHz	30MHz ~ 200MHz	3.86 dB
	200MHz ~ 1000MHz	3.87 dB
Radiated Emissions above 1 GHz	1GHz ~ 18GHz	2.29 dB
	18GHz ~ 40GHz	2.29 dB

2.2 Modification Record

There were no modifications required for compliance.

3 General Information

3.1 General Description of EUT

Product	Secured Wireless Access Point
Brand	Fortinet Inc.
Test Model	FAP-221E, FAP-223E
Series Model	FortiAP 221Exxxxx, FAP-221Exxxxx, FORTIAP-221Exxxxx, FortiAP 223Exxxxx, FAP-223Exxxxx, FORTIAP-223Exxxxx (where “x” can be used as “A-Z”, or “0-9”, or “-”, or blank for marketing purposes only)
Model Difference	Refer to note for more details
Sample Status	Engineering sample
Power Supply Rating	12Vdc from adapter 54Vdc from POE
Modulation Type	CCK, DQPSK, DBPSK for DSSS 64QAM, 16QAM, QPSK, BPSK for OFDM
Modulation Technology	DSSS, OFDM
Transfer Rate	802.11b: 11.0/ 5.5/ 2.0/ 1.0Mbps 802.11g: 54.0/ 48.0/ 36.0/ 24.0/ 18.0/ 12.0/ 9.0/ 6.0Mbps 802.11n: up to 300Mbps
Operating Frequency	2412 ~ 2462MHz
Number of Channel	11 for 802.11b, 802.11g, 802.11n (HT20) 7 for 802.11n (HT40)
Output Power	CDD Mode: 303.063mW Beamforming Mode: 139.975mW
Antenna Type	Refer to note
Antenna Connector	Refer to note
Accessory Device	Adapter (option)
Data Cable Supplied	NA

Note:

1. All models are listed as below. Model: FAP-221E and FAP-223E were chosen for final test.

Brand	Model	Difference
Fortinet Inc.	FortiAP 221Exxxxx	With Internal Antenna
	FAP-221Exxxxx (Main test model: FAP-221E)	
	FORTIAP-221Exxxxx	
	FortiAP 223Exxxxx	With External Antenna
	FAP-223Exxxxx (Main test model: FAP-223E)	
	FORTIAP-223Exxxxx	

where “x” can be used as “A-Z”, or “0-9”, or “-”, or blank for marketing purposes only

2. The EUT incorporates a MIMO function. Physically, the EUT provides 2 completed transmitters and 2 receivers.

Modulation Mode	TX Function	Beamforming
802.11b	2TX	Not Support
802.11g	2TX	Not Support
802.11n (HT20)	2TX	Support
802.11n (HT40)	2TX	Support

* For 2.4GHz band, CDD mode is the worst case for final tests except RF output power test after pretesting CDD mode and beamforming mode.

3. The EUT uses following antennas.

For Model: FAP-221E (Internal antenna)

Antenna Type	Printed	Antenna Connector	IPEX
Gain (dBi)	Frequency (MHz)		
	2400-2500	5150-5850	
Internal Ant. 1	4.4	-	
Internal Ant. 2	4.5	-	
Internal Ant. 3	-	5.6	
Internal Ant. 4	-	5.6	

For Model: FAP-223E (External antenna)

Antenna Type	Dipole		Antenna Connector		RP SMA plug	
Gain (dBi)	Frequency (MHz)					
	2400	2450	2500	5150	5550	5850
External Ant.	4.06	4.26	4.58	5.27	5.35	5.04

* The highest antenna gain was chosen for antenna port conducted measurement tested only

4. 2.4GHz and 5GHz technology can transmit at same time.

5. Spurious emission of the simultaneous operation (2.4GHz and 5GHz) has been evaluated and no non-compliance was found.

3.2 Description of Test Modes

11 channels are provided for 802.11b, 802.11g and 802.11n (HT20):

Channel	Frequency	Channel	Frequency
1	2412MHz	7	2442MHz
2	2417MHz	8	2447MHz
3	2422MHz	9	2452MHz
4	2427MHz	10	2457MHz
5	2432MHz	11	2462MHz
6	2437MHz		

7 channels are provided for 802.11n (HT40):

Channel	Frequency	Channel	Frequency
3	2422MHz	7	2442MHz
4	2427MHz	8	2447MHz
5	2432MHz	9	2452MHz
6	2437MHz		

3.2.1 Test Mode Applicability and Tested Channel Detail

EUT CONFIGURE MODE	APPLICABLE TO				DESCRIPTION
	RE \geq 1G	RE $<$ 1G	PLC	APCM	
A	√	√	√	-	Model: FAP-221E Power from adapter
B	-	√	√	-	Model: FAP-221E Power from POE
C	√	√	√	√	Model: FAP-223E Power from adapter
D	-	√	√	-	Model: FAP-223E Power from POE

Where **RE \geq 1G**: Radiated Emission above 1GHz & Bandedge Measurement
RE $<$ 1G: Radiated Emission below 1GHz
PLC: Power Line Conducted Emission
APCM: Antenna Port Conducted Measurement

Note:

1. The EUT had been pre-tested on the positioned of each 3 axis. The worst case was found when positioned on **Z-plane**.
2. "-" means no effect.

Radiated Emission Test (Above 1GHz):

- Pre-Scan has been conducted to determine the worst-case mode from all possible combinations between available modulations, data rates and antenna ports (if EUT with antenna diversity architecture).
- Following channel(s) was (were) selected for the final test as listed below.

EUT CONFIGURE MODE	MODE	AVAILABLE CHANNEL	TESTED CHANNEL	MODULATION TECHNOLOGY	MODULATION TYPE	DATA RATE (MBPS)
A, C	802.11b	1 to 11	1, 6, 11	DSSS	DBPSK	1.0
A, C	802.11g	1 to 11	1, 6, 11	OFDM	BPSK	6.0
A, C	802.11n (HT20)	1 to 11	1, 6, 11	OFDM	BPSK	7.2
A, C	802.11n (HT40)	3 to 9	3, 6, 9	OFDM	BPSK	15.0

Radiated Emission Test (Below 1GHz):

- Pre-Scan has been conducted to determine the worst-case mode from all possible combinations between available modulations, data rates and antenna ports (if EUT with antenna diversity architecture).
- Following channel(s) was (were) selected for the final test as listed below.

EUT CONFIGURE MODE	MODE	AVAILABLE CHANNEL	TESTED CHANNEL	MODULATION TECHNOLOGY	MODULATION TYPE	DATA RATE (MBPS)
A, B, C, D	802.11b	1 to 11	1	DSSS	DBPSK	1.0

Power Line Conducted Emission Test:

- Pre-Scan has been conducted to determine the worst-case mode from all possible combinations between available modulations, data rates and antenna ports (if EUT with antenna diversity architecture).
- Following channel(s) was (were) selected for the final test as listed below.

EUT CONFIGURE MODE	MODE	AVAILABLE CHANNEL	TESTED CHANNEL	MODULATION TECHNOLOGY	MODULATION TYPE	DATA RATE (MBPS)
A, B, C, D	802.11b	1 to 11	1	DSSS	DBPSK	1.0

6dB Bandwidth, Power Spectral Density and Conducted Out of Band Emission Measurement:

- This item includes all test value of each mode, but only includes spectrum plot of worst value of each mode.
- Pre-Scan has been conducted to determine the worst-case mode from all possible combinations between available modulations, data rates and antenna ports (if EUT with antenna diversity architecture).
- Following channel(s) was (were) selected for the final test as listed below.

EUT CONFIGURE MODE	MODE	AVAILABLE CHANNEL	TESTED CHANNEL	MODULATION TECHNOLOGY	MODULATION TYPE	DATA RATE (MBPS)
C	802.11b	1 to 11	1, 6, 11	DSSS	DBPSK	1.0
C	802.11g	1 to 11	1, 6, 11	OFDM	BPSK	6.0
C	802.11n (HT20)	1 to 11	1, 6, 11	OFDM	BPSK	7.2
C	802.11n (HT40)	3 to 9	3, 6, 9	OFDM	BPSK	15.0

Conducted Output Power Measurement:

- This item includes all test value of each mode, but only includes spectrum plot of worst value of each mode.
- Pre-Scan has been conducted to determine the worst-case mode from all possible combinations between available modulations, data rates and antenna ports (if EUT with antenna diversity architecture).
- Following channel(s) was (were) selected for the final test as listed below.

EUT CONFIGURE MODE	MODE	AVAILABLE CHANNEL	TESTED CHANNEL	MODULATION TECHNOLOGY	MODULATION TYPE	DATA RATE (MBPS)
CDD Mode						
C	802.11b	1 to 11	1, 6, 11	DSSS	DBPSK	1.0
C	802.11g	1 to 11	1, 6, 11	OFDM	BPSK	6.0
C	802.11n (HT20)	1 to 11	1, 6, 11	OFDM	BPSK	7.2
C	802.11n (HT40)	3 to 9	3, 6, 9	OFDM	BPSK	15.0
Beamforming Mode						
C	802.11n (HT20)	1 to 11	1, 6, 11	OFDM	BPSK	7.2
C	802.11n (HT40)	3 to 9	3, 6, 9	OFDM	BPSK	15.0

Test Condition:

APPLICABLE TO	ENVIRONMENTAL CONDITIONS	INPUT POWER	TESTED BY
RE≥1G	18deg. C, 65%RH 18deg. C, 70%RH	120Vac, 60Hz	Jones Chang Nick Hsu
RE<1G	21deg. C, 69%RH 18deg. C, 70%RH	120Vac, 60Hz 54Vdc	James Yang Jones Chang
PLC	23deg. C, 70%RH	120Vac, 60Hz 54Vdc	Jones Chang
APCM	16deg. C, 70%RH	120Vac, 60Hz	Nick Hsu

3.3 Duty Cycle of Test Signal

802.11b: Duty cycle of test signal is 100%, duty factor is not required.

802.11n (HT20): Duty cycle of test signal is > 98%, duty factor is not required.

802.11g, 802.11n (HT40): Duty cycle of test signal is < 98%, duty factor shall be considered.

802.11g: Duty cycle = $2.060/2.163 = 0.952$, Duty factor = $10 * \log(1/0.952) = 0.21$

802.11n (HT20): Duty cycle = $5.000/5.083 = 0.984$

802.11n (HT40): Duty cycle = $2.422/2.512 = 0.964$, Duty factor = $10 * \log(1/0.964) = 0.16$

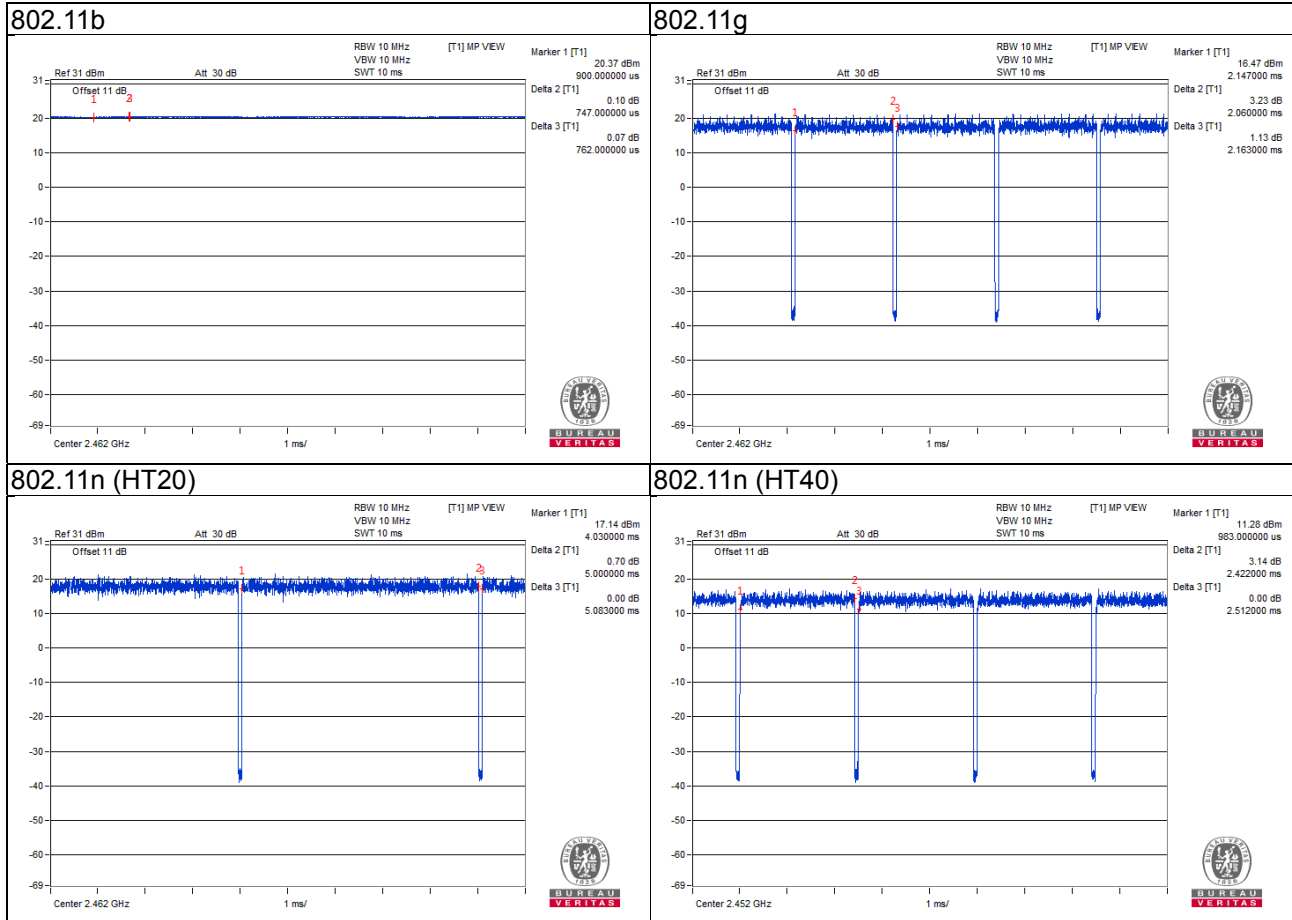

3.4 Description of Support Units

The EUT has been tested as an independent unit together with other necessary accessories or support units. The following support units or accessories were used to form a representative test configuration during the tests.

ID	Product	Brand	Model No.	Serial No.	FCC ID	Remarks
A.	Notebook	DELL	Latitude E6420	HPFC5Q1	FCC DoC Approved	-
B.	Adapter	Asian Power Devices Inc.	WA-30J12R	NA	NA	Option of EUT I/P: 100-240Vac, 50-60Hz, 0.9A Max. O/P: 12Vdc, 2.5A 1.8m power cable without core attached on adapter For test mode A and C only
C.	POE	EnGenius	EPA5006GAT	NA	NA	Provided by client I/P: 100-240Vac, 50-60Hz 0.8A O/P: 54Vdc, 0.6A 0.5m power cable without core For test mode B and D only

Note:

1. All power cords of the above support units are non-shielded (1.8m).
2. Item A acted as communication partner to transfer data.

ID	Descriptions	Qty.	Length (m)	Shielding (Yes/No)	Cores (Qty.)	Remarks
1.	RJ45 Cable	1	3	N	0	Cat5e
2.	RJ45 Cable	1	1.8	N	0	Cat5e For test mode B and D only

3.4.1 Configuration of System under Test

Test Mode A, C

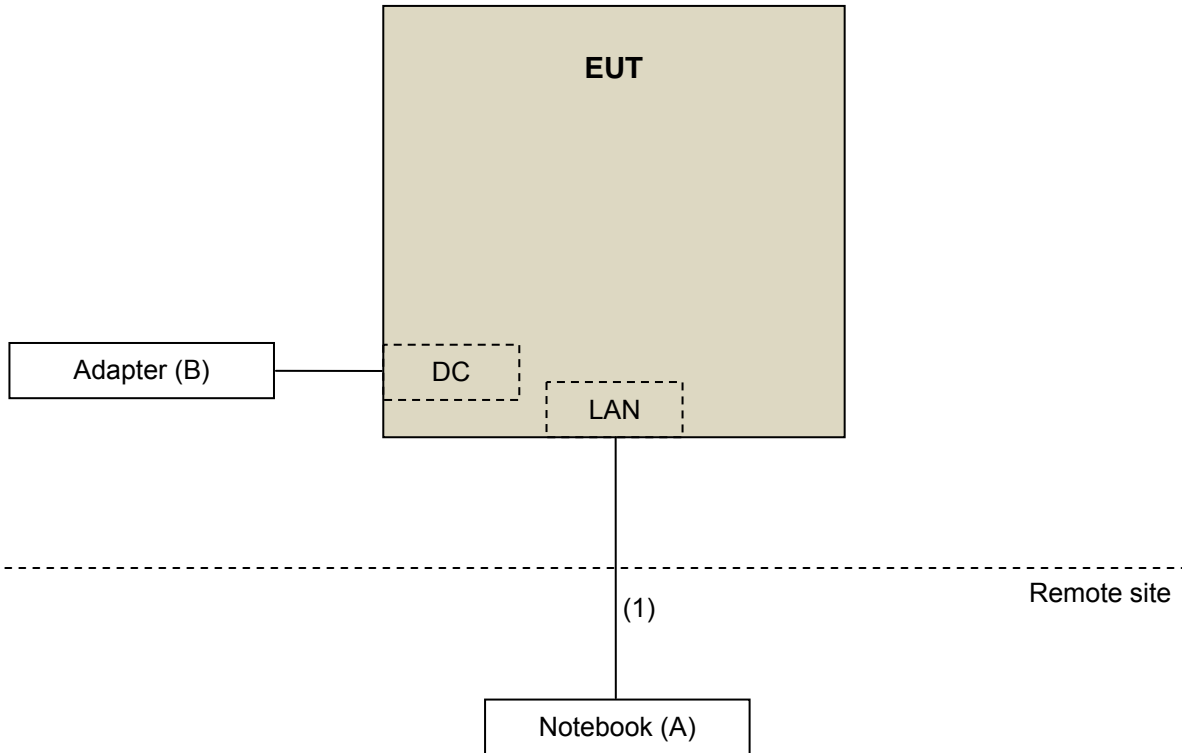

Test Mode B, D

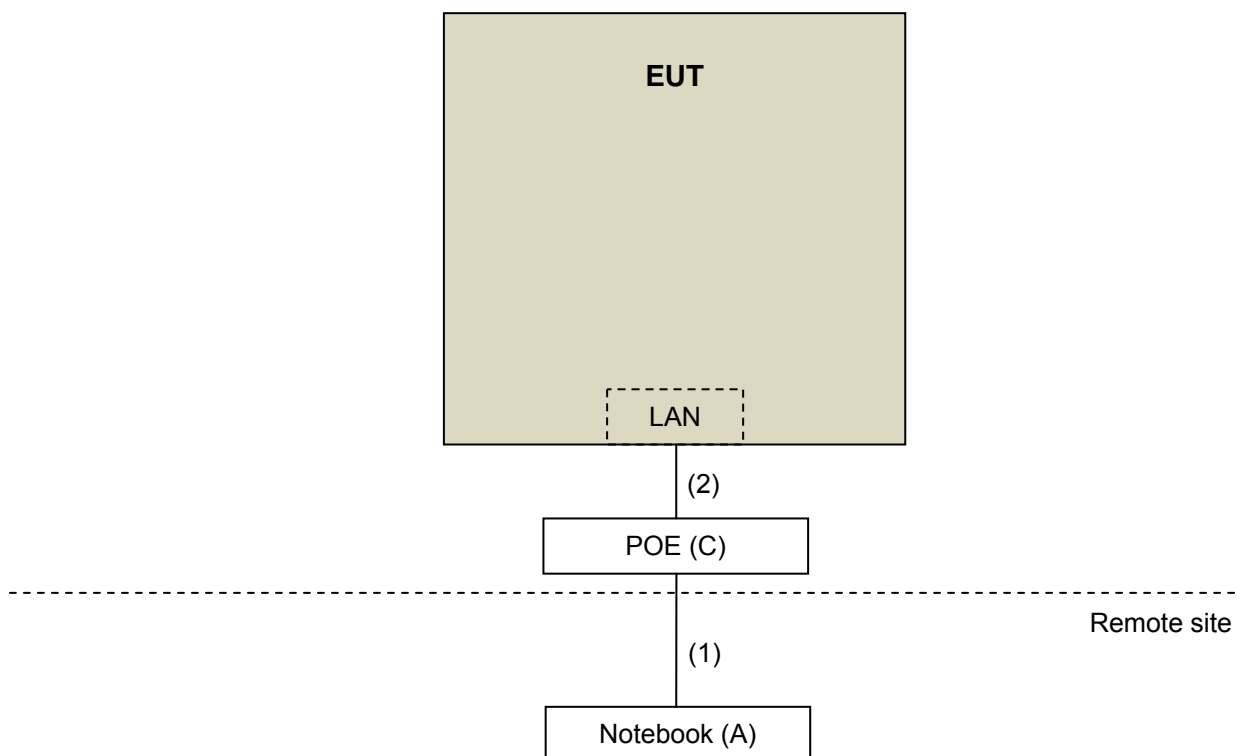

3.5 General Description of Applied Standards

The EUT is a RF Product. According to the specifications of the manufacturer, it must comply with the requirements of the following standards:

FCC Part 15, Subpart C (15.247)

KDB 558074 D01 DTS Meas Guidance v04

KDB 662911 D01 Multiple Transmitter Output v02r01

ANSI C63.10-2013

All test items have been performed and recorded as per the above standards.

Note: The EUT has been verified to comply with the requirements of FCC Part 15, Subpart B, Class B (DoC).
The test report has been issued separately.

4 Test Types and Results

4.1 Radiated Emission and Bandedge Measurement

4.1.1 Limits of Radiated Emission and Bandedge Measurement

Radiated emissions which fall in the restricted bands must comply with the radiated emission limits specified as below table. Other emissions shall be at least 30dB below the highest level of the desired power:

Frequencies (MHz)	Field Strength (microvolts/meter)	Measurement Distance (meters)
0.009 ~ 0.490	2400/F(kHz)	300
0.490 ~ 1.705	24000/F(kHz)	30
1.705 ~ 30.0	30	30
30 ~ 88	100	3
88 ~ 216	150	3
216 ~ 960	200	3
Above 960	500	3

Note:

1. The lower limit shall apply at the transition frequencies.
2. Emission level (dBuV/m) = 20 log Emission level (uV/m).
3. For frequencies above 1000MHz, the field strength limits are based on average detector, however, the peak field strength of any emission shall not exceed the maximum permitted average limits, specified above by more than 30dB under any condition of modulation.

4.1.2 Test Instruments

Description & Manufacturer	Model No.	Serial No.	Cal. Date	Cal. Due
Test Receiver ROHDE & SCHWARZ	ESIB7	100187	Apr. 18, 2016	Apr. 17, 2017
Spectrum Analyzer ROHDE & SCHWARZ	FSP40	100041	Nov. 16, 2015	Nov. 15, 2016
			Nov. 16, 2016	Nov. 15, 2017
BILOG Antenna SCHWARZBECK	VULB9168	9168-171	Dec. 28, 2015	Dec. 27, 2016
			Dec. 28, 2016	Dec. 27, 2017
HORN Antenna SCHWARZBECK	9120D	209	Dec. 27, 2015	Dec. 26, 2016
			Dec. 27, 2016	Dec. 26, 2017
HORN Antenna SCHWARZBECK	BBHA 9170	BBHA9170241	Dec. 14, 2015	Dec. 13, 2016
			Dec. 14, 2016	Dec. 13, 2017
Loop Antenna	EM-6879	269	Aug. 11, 2016	Aug. 10, 2017
Preamplifier Agilent	8447D	2944A10738	Aug. 22, 2016	Aug. 21, 2017
Preamplifier Agilent	8449B	3008A01922	Sep. 18, 2016	Sep. 17, 2017
RF signal cable HUBER+SUHNER	SUCOFLEX 104	Cable-CH3-03 (214378)	Aug. 22, 2016	Aug. 21, 2017
RF signal cable HUBER+SUHNER	SUCOFLEX 106	Cable-CH3-03 (309224+12738)	Aug. 22, 2016	Aug. 21, 2017
Software BV ADT	ADT_Radiated_ V7.6.15.9.4	NA	NA	NA
Antenna Tower inn-co GmbH	MA 4000	013303	NA	NA
Antenna Tower Controller BV ADT	AT100	AT93021702	NA	NA
Turn Table BV ADT	TT100	TT93021702	NA	NA
Turn Table Controller BV ADT	SC100	SC93021702	NA	NA
High Speed Peak Power Meter	ML2495A	0824012	Aug. 11, 2016	Aug. 10, 2017
Power Sensor	MA2411B	0738171	Aug. 11, 2016	Aug. 10, 2017

- Note:
1. The calibration interval of the above test instruments is 12 months and the calibrations are traceable to NML/ROC and NIST/USA.
 2. The test was performed in HwaYa Chamber 3.
 3. The horn antenna and preamplifier (model: 8449B) are used only for the measurement of emission frequency above 1GHz if tested.
 4. The FCC Site Registration No. is 988962.
 5. The IC Site Registration No. is IC 7450F-3.

4.1.3 Test Procedures

For Radiated emission below 30MHz

- a. The EUT was placed on the top of a rotating table 0.8 meters above the ground at a 3 meter chamber room. The table was rotated 360 degrees to determine the position of the highest radiation.
- b. The EUT was set 3 meters away from the interference-receiving antenna, which was mounted on the top of a variable-height antenna tower.
- c. Both X and Y axes of the antenna are set to make the measurement.
- d. For each suspected emission, the EUT was arranged to its worst case and the rotatable table was turned from 0 degrees to 360 degrees to find the maximum reading.
- e. The test-receiver system was set to Quasi-Peak Detect Function and Specified Bandwidth with Maximum Hold Mode.

Note:

1. The resolution bandwidth and video bandwidth of test receiver/spectrum analyzer is 9kHz at frequency below 30MHz.

For Radiated emission above 30MHz

- a. The EUT was placed on the top of a rotating table 0.8 meters (for 30MHz ~ 1GHz) / 1.5 meters (for above 1GHz) above the ground at 3 meter chamber room for test. The table was rotated 360 degrees to determine the position of the highest radiation.
- b. The EUT was set 3 meters away from the interference-receiving antenna, which was mounted on the top of a variable-height antenna tower.
- c. The height of antenna is varied from one meter to four meters above the ground to determine the maximum value of the field strength. Both horizontal and vertical polarizations of the antenna are set to make the measurement.
- d. For each suspected emission, the EUT was arranged to its worst case and then the antenna was tuned to heights from 1 meter to 4 meters and the rotatable table was turned from 0 degrees to 360 degrees to find the maximum reading.
- e. The test-receiver system was set to quasi-peak detect function and specified bandwidth with maximum hold mode when the test frequency is below 1 GHz.
- f. The test-receiver system was set to peak and average detect function and specified bandwidth with maximum hold mode when the test frequency is above 1 GHz. If the peak reading value also meets average limit, measurement with the average detector is unnecessary.

Note:

1. The resolution bandwidth and video bandwidth of test receiver/spectrum analyzer is 120kHz for Quasi-peak detection (QP) at frequency below 1GHz.
2. The resolution bandwidth of test receiver/spectrum analyzer is 1 MHz and the video bandwidth is 3 MHz for Peak detection (PK) at frequency above 1GHz.
3. The resolution bandwidth of test receiver/spectrum analyzer is 1 MHz and the video bandwidth is $\geq 1/T$ (Duty cycle < 98%) or 3 x RBW (Duty cycle $\geq 98\%$) for Average detection (AV) at frequency above 1GHz.
4. All modes of operation were investigated and the worst-case emissions are reported.

4.1.4 Deviation from Test Standard

No deviation.

4.1.5 Test Set Up

For Radiated emission below 30MHz

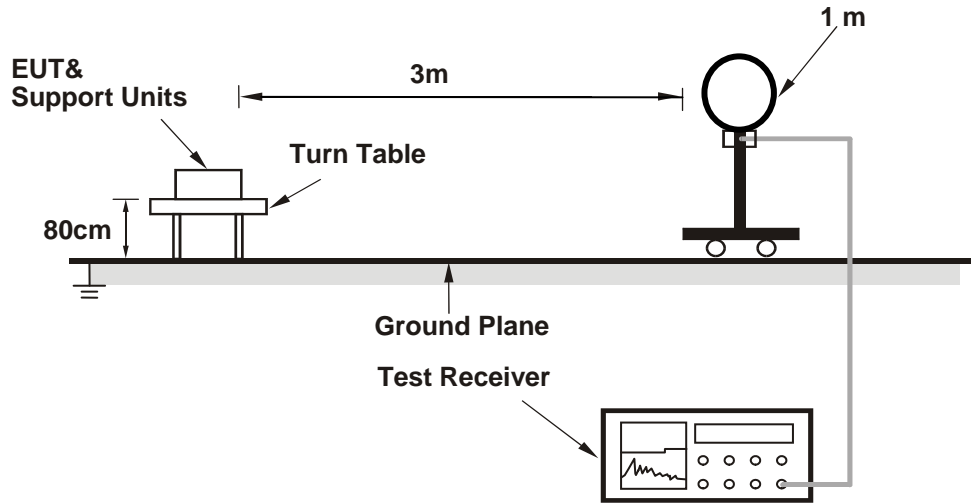

For Radiated emission 30MHz to 1GHz

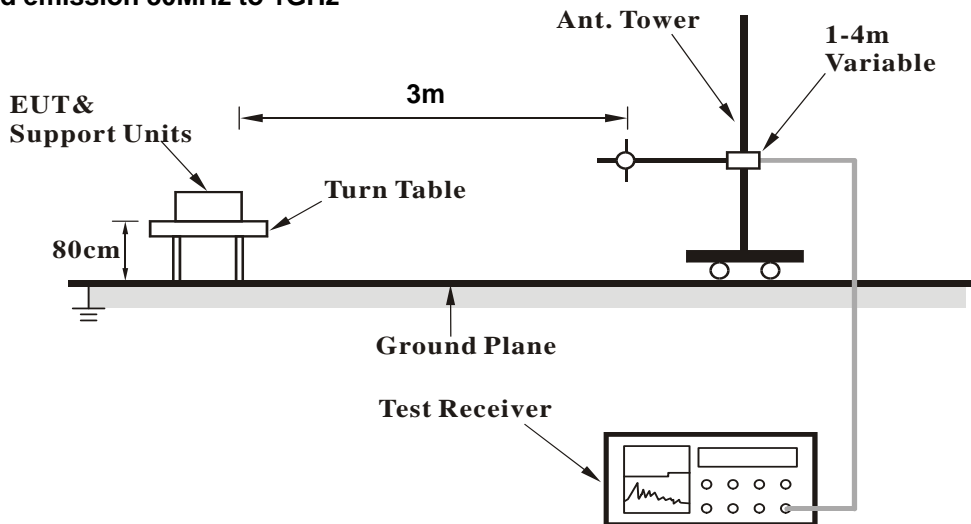

For Radiated emission above 1GHz

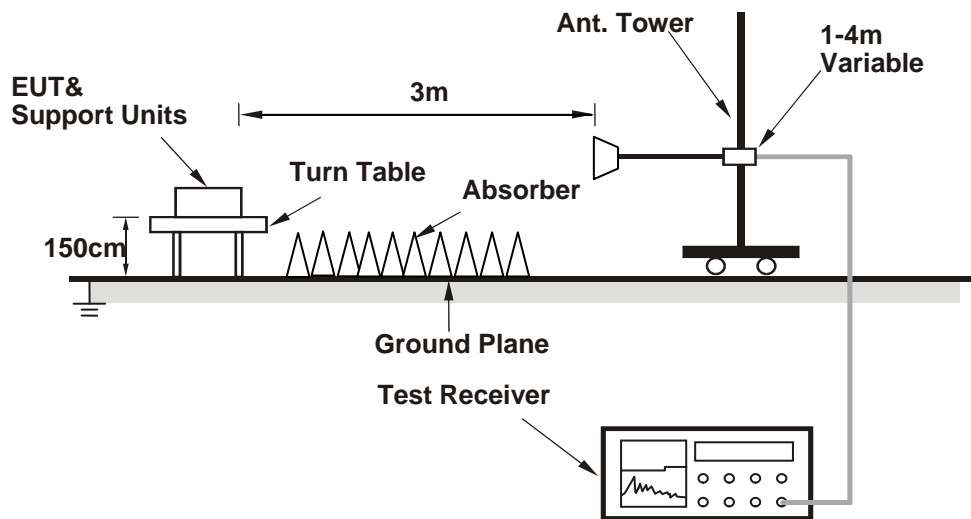

For the actual test configuration, please refer to the attached file (Test Setup Photo).

4.1.6 EUT Operating Conditions

- a. Placed the EUT on the testing table.
- b. Prepared a notebook to act as a communication partner and placed it outside of testing area.
- c. The communication partner connected with EUT via a RJ45 cable and ran a test program (provided by manufacturer) to enable EUT under transmission condition continuously at specific channel frequency.
- d. The communication partner sent data to EUT by command "PING".

4.1.7 Test Results

Above 1GHz worst-Case data:

Test Mode A

802.11b

CHANNEL	TX Channel 1	DETECTOR FUNCTION	Peak (PK)
FREQUENCY RANGE	1GHz ~ 25GHz		Average (AV)

ANTENNA POLARITY & TEST DISTANCE: HORIZONTAL AT 3 M								
NO.	FREQ. (MHz)	EMISSION LEVEL (dBuV/m)	LIMIT (dBuV/m)	MARGIN (dB)	ANTENNA HEIGHT (m)	TABLE ANGLE (Degree)	RAW VALUE (dBuV)	CORRECTION FACTOR (dB/m)
1	2390.00	56.3 PK	74.0	-17.7	1.21 H	5	25.4	30.9
2	2390.00	45.4 AV	54.0	-8.6	1.21 H	5	14.5	30.9
3	*2412.00	107.6 PK			1.22 H	355	76.5	31.1
4	*2412.00	103.6 AV			1.22 H	355	72.5	31.1
5	4824.00	55.4 PK	74.0	-18.6	2.19 H	352	50.9	4.5
6	4824.00	52.5 AV	54.0	-1.5	2.19 H	352	48.0	4.5
ANTENNA POLARITY & TEST DISTANCE: VERTICAL AT 3 M								
NO.	FREQ. (MHz)	EMISSION LEVEL (dBuV/m)	LIMIT (dBuV/m)	MARGIN (dB)	ANTENNA HEIGHT (m)	TABLE ANGLE (Degree)	RAW VALUE (dBuV)	CORRECTION FACTOR (dB/m)
1	2390.00	56.0 PK	74.0	-18.0	1.56 V	310	25.1	30.9
2	2390.00	44.3 AV	54.0	-9.7	1.56 V	310	13.4	30.9
3	*2412.00	109.3 PK			2.52 V	3	78.2	31.1
4	*2412.00	107.0 AV			2.52 V	3	75.9	31.1
5	4824.00	55.6 PK	74.0	-18.4	1.38 V	328	51.1	4.5
6	4824.00	52.3 AV	54.0	-1.7	1.38 V	328	47.8	4.5

Remarks:

1. Emission Level(dBuV/m) = Raw Value(dBuV) + Correction Factor(dB/m)
2. Correction Factor(dB/m) = Antenna Factor(dB/m) + Cable Factor(dB) – Pre-Amplifier Factor(dB)
3. The other emission levels were very low against the limit.
4. Margin value = Emission Level – Limit value
5. " * ": Fundamental frequency.

CHANNEL	TX Channel 6	DETECTOR FUNCTION	Peak (PK)
FREQUENCY RANGE	1GHz ~ 25GHz		Average (AV)

ANTENNA POLARITY & TEST DISTANCE: HORIZONTAL AT 3 M

NO.	FREQ. (MHz)	EMISSION LEVEL (dBuV/m)	LIMIT (dBuV/m)	MARGIN (dB)	ANTENNA HEIGHT (m)	TABLE ANGLE (Degree)	RAW VALUE (dBuV)	CORRECTION FACTOR (dB/m)
1	*2437.00	108.8 PK			1.10 H	300	77.7	31.1
2	*2437.00	105.0 AV			1.10 H	300	73.9	31.1
3	4874.00	55.3 PK	74.0	-18.7	2.15 H	355	50.7	4.6
4	4874.00	52.5 AV	54.0	-1.5	2.15 H	355	47.9	4.6

ANTENNA POLARITY & TEST DISTANCE: VERTICAL AT 3 M

NO.	FREQ. (MHz)	EMISSION LEVEL (dBuV/m)	LIMIT (dBuV/m)	MARGIN (dB)	ANTENNA HEIGHT (m)	TABLE ANGLE (Degree)	RAW VALUE (dBuV)	CORRECTION FACTOR (dB/m)
1	*2437.00	107.3 PK			2.25 V	332	76.2	31.1
2	*2437.00	103.5 AV			2.25 V	332	72.4	31.1
3	4874.00	54.6 PK	74.0	-19.4	1.34 V	323	50.0	4.6
4	4874.00	51.1 AV	54.0	-2.9	1.34 V	323	46.5	4.6

Remarks:

1. Emission Level(dBuV/m) = Raw Value(dBuV) + Correction Factor(dB/m)
2. Correction Factor(dB/m) = Antenna Factor(dB/m) + Cable Factor(dB) – Pre-Amplifier Factor(dB)
3. The other emission levels were very low against the limit.
4. Margin value = Emission Level – Limit value
5. " * ": Fundamental frequency.

CHANNEL	TX Channel 11	DETECTOR FUNCTION	Peak (PK)
FREQUENCY RANGE	1GHz ~ 25GHz		Average (AV)

ANTENNA POLARITY & TEST DISTANCE: HORIZONTAL AT 3 M

NO.	FREQ. (MHz)	EMISSION LEVEL (dBuV/m)	LIMIT (dBuV/m)	MARGIN (dB)	ANTENNA HEIGHT (m)	TABLE ANGLE (Degree)	RAW VALUE (dBuV)	CORRECTION FACTOR (dB/m)
1	*2462.00	110.1 PK			1.26 H	307	78.9	31.2
2	*2462.00	106.3 AV			1.26 H	307	75.1	31.2
3	2483.50	58.8 PK	74.0	-15.2	1.18 H	308	27.5	31.3
4	2483.50	50.0 AV	54.0	-4.0	1.18 H	308	18.7	31.3
5	4924.00	54.7 PK	74.0	-19.3	2.10 H	352	50.2	4.5
6	4924.00	52.0 AV	54.0	-2.0	2.10 H	352	47.5	4.5

ANTENNA POLARITY & TEST DISTANCE: VERTICAL AT 3 M

NO.	FREQ. (MHz)	EMISSION LEVEL (dBuV/m)	LIMIT (dBuV/m)	MARGIN (dB)	ANTENNA HEIGHT (m)	TABLE ANGLE (Degree)	RAW VALUE (dBuV)	CORRECTION FACTOR (dB/m)
1	*2462.00	108.6 PK			2.59 V	326	77.4	31.2
2	*2462.00	104.7 AV			2.59 V	326	73.5	31.2
3	2483.50	58.6 PK	74.0	-15.4	1.43 V	337	27.3	31.3
4	2483.50	50.2 AV	54.0	-3.8	1.43 V	337	18.9	31.3
5	4924.00	57.3 PK	74.0	-16.7	1.33 V	321	52.8	4.5
6	4924.00	52.5 AV	54.0	-1.5	1.33 V	321	48.0	4.5

Remarks:

1. Emission Level(dBuV/m) = Raw Value(dBuV) + Correction Factor(dB/m)
2. Correction Factor(dB/m) = Antenna Factor(dB/m) + Cable Factor(dB) – Pre-Amplifier Factor(dB)
3. The other emission levels were very low against the limit.
4. Margin value = Emission Level – Limit value
5. " * ": Fundamental frequency.

802.11g

CHANNEL	TX Channel 1	DETECTOR FUNCTION	Peak (PK) Average (AV)
FREQUENCY RANGE	1GHz ~ 25GHz		

ANTENNA POLARITY & TEST DISTANCE: HORIZONTAL AT 3 M

NO.	FREQ. (MHz)	EMISSION LEVEL (dBuV/m)	LIMIT (dBuV/m)	MARGIN (dB)	ANTENNA HEIGHT (m)	TABLE ANGLE (Degree)	RAW VALUE (dBuV)	CORRECTION FACTOR (dB/m)
1	2390.00	68.4 PK	74.0	-5.6	1.75 H	296	37.5	30.9
2	2390.00	51.9 AV	54.0	-2.1	1.75 H	296	21.0	30.9
3	*2412.00	108.1 PK			1.69 H	310	77.0	31.1
4	*2412.00	98.1 AV			1.69 H	310	67.0	31.1
5	4824.00	49.2 PK	74.0	-24.8	2.20 H	352	44.7	4.5
6	4824.00	36.6 AV	54.0	-17.4	2.20 H	352	32.1	4.5

ANTENNA POLARITY & TEST DISTANCE: VERTICAL AT 3 M

NO.	FREQ. (MHz)	EMISSION LEVEL (dBuV/m)	LIMIT (dBuV/m)	MARGIN (dB)	ANTENNA HEIGHT (m)	TABLE ANGLE (Degree)	RAW VALUE (dBuV)	CORRECTION FACTOR (dB/m)
1	2390.00	68.4 PK	74.0	-5.6	2.85 V	10	37.5	30.9
2	2390.00	52.3 AV	54.0	-1.7	2.85 V	10	21.4	30.9
3	*2412.00	109.4 PK			3.11 V	0	78.3	31.1
4	*2412.00	98.8 AV			3.11 V	0	67.7	31.1
5	4824.00	49.0 PK	74.0	-25.0	1.39 V	324	44.5	4.5
6	4824.00	35.6 AV	54.0	-18.4	1.39 V	324	31.1	4.5

Remarks:

1. Emission Level(dBuV/m) = Raw Value(dBuV) + Correction Factor(dB/m)
2. Correction Factor(dB/m) = Antenna Factor(dB/m) + Cable Factor(dB) – Pre-Amplifier Factor(dB)
3. The other emission levels were very low against the limit.
4. Margin value = Emission Level – Limit value
5. " * ": Fundamental frequency.

CHANNEL	TX Channel 6	DETECTOR FUNCTION	Peak (PK)
FREQUENCY RANGE	1GHz ~ 25GHz		Average (AV)

ANTENNA POLARITY & TEST DISTANCE: HORIZONTAL AT 3 M

NO.	FREQ. (MHz)	EMISSION LEVEL (dBuV/m)	LIMIT (dBuV/m)	MARGIN (dB)	ANTENNA HEIGHT (m)	TABLE ANGLE (Degree)	RAW VALUE (dBuV)	CORRECTION FACTOR (dB/m)
1	*2437.00	113.3 PK			1.10 H	304	82.2	31.1
2	*2437.00	103.7 AV			1.10 H	304	72.6	31.1
3	2483.50	67.0 PK	74.0	-7.0	1.15 H	302	35.7	31.3
4	2483.50	51.1 AV	54.0	-2.9	1.15 H	302	19.8	31.3
5	4874.00	60.6 PK	74.0	-13.4	2.01 H	358	56.0	4.6
6	4874.00	47.2 AV	54.0	-6.8	2.01 H	358	42.6	4.6

ANTENNA POLARITY & TEST DISTANCE: VERTICAL AT 3 M

NO.	FREQ. (MHz)	EMISSION LEVEL (dBuV/m)	LIMIT (dBuV/m)	MARGIN (dB)	ANTENNA HEIGHT (m)	TABLE ANGLE (Degree)	RAW VALUE (dBuV)	CORRECTION FACTOR (dB/m)
1	*2437.00	114.3 PK			2.72 V	351	83.2	31.1
2	*2437.00	103.3 AV			2.72 V	351	72.2	31.1
3	2483.50	67.3 PK	74.0	-6.7	2.28 V	0	36.0	31.3
4	2483.50	52.6 AV	54.0	-1.4	2.28 V	0	21.3	31.3
5	4874.00	58.8 PK	74.0	-15.2	1.26 V	321	54.2	4.6
6	4874.00	46.4 AV	54.0	-7.6	1.26 V	321	41.8	4.6

Remarks:

1. Emission Level(dBuV/m) = Raw Value(dBuV) + Correction Factor(dB/m)
2. Correction Factor(dB/m) = Antenna Factor(dB/m) + Cable Factor(dB) – Pre-Amplifier Factor(dB)
3. The other emission levels were very low against the limit.
4. Margin value = Emission Level – Limit value
5. " * ": Fundamental frequency.

CHANNEL	TX Channel 11	DETECTOR FUNCTION	Peak (PK)
FREQUENCY RANGE	1GHz ~ 25GHz		Average (AV)

ANTENNA POLARITY & TEST DISTANCE: HORIZONTAL AT 3 M								
NO.	FREQ. (MHz)	EMISSION LEVEL (dBuV/m)	LIMIT (dBuV/m)	MARGIN (dB)	ANTENNA HEIGHT (m)	TABLE ANGLE (Degree)	RAW VALUE (dBuV)	CORRECTION FACTOR (dB/m)
1	*2462.00	107.8 PK			1.76 H	289	76.6	31.2
2	*2462.00	98.0 AV			1.76 H	289	66.8	31.2
3	2483.50	67.9 PK	74.0	-6.1	1.72 H	3	36.6	31.3
4	2483.50	52.9 AV	54.0	-1.1	1.72 H	3	21.6	31.3
5	4924.00	50.8 PK	74.0	-23.2	2.17 H	0	46.3	4.5
6	4924.00	36.8 AV	54.0	-17.2	2.17 H	0	32.3	4.5

ANTENNA POLARITY & TEST DISTANCE: VERTICAL AT 3 M								
NO.	FREQ. (MHz)	EMISSION LEVEL (dBuV/m)	LIMIT (dBuV/m)	MARGIN (dB)	ANTENNA HEIGHT (m)	TABLE ANGLE (Degree)	RAW VALUE (dBuV)	CORRECTION FACTOR (dB/m)
1	*2462.00	109.3 PK			3.03 V	0	78.1	31.2
2	*2462.00	99.4 AV			3.03 V	0	68.2	31.2
3	2483.50	68.8 PK	74.0	-5.2	2.97 V	0	37.5	31.3
4	2483.50	53.0 AV	54.0	-1.0	2.97 V	0	21.7	31.3
5	4924.00	49.5 PK	74.0	-24.5	1.38 V	311	45.0	4.5
6	4924.00	36.5 AV	54.0	-17.5	1.38 V	311	32.0	4.5

Remarks:

1. Emission Level(dBuV/m) = Raw Value(dBuV) + Correction Factor(dB/m)
2. Correction Factor(dB/m) = Antenna Factor(dB/m) + Cable Factor(dB) – Pre-Amplifier Factor(dB)
3. The other emission levels were very low against the limit.
4. Margin value = Emission Level – Limit value
5. " * ": Fundamental frequency.

802.11n (HT20)

CHANNEL	TX Channel 1	DETECTOR FUNCTION	Peak (PK)
FREQUENCY RANGE	1GHz ~ 25GHz		Average (AV)

ANTENNA POLARITY & TEST DISTANCE: HORIZONTAL AT 3 M

NO.	FREQ. (MHz)	EMISSION LEVEL (dBuV/m)	LIMIT (dBuV/m)	MARGIN (dB)	ANTENNA HEIGHT (m)	TABLE ANGLE (Degree)	RAW VALUE (dBuV)	CORRECTION FACTOR (dB/m)
1	2390.00	61.9 PK	74.0	-12.1	1.20 H	316	31.0	30.9
2	2390.00	52.6 AV	54.0	-1.4	1.20 H	316	21.7	30.9
3	*2412.00	109.2 PK			1.48 H	300	78.1	31.1
4	*2412.00	99.0 AV			1.48 H	300	67.9	31.1
5	4824.00	49.2 PK	74.0	-24.8	2.01 H	353	44.7	4.5
6	4824.00	35.1 AV	54.0	-18.9	2.01 H	353	30.6	4.5

ANTENNA POLARITY & TEST DISTANCE: VERTICAL AT 3 M

NO.	FREQ. (MHz)	EMISSION LEVEL (dBuV/m)	LIMIT (dBuV/m)	MARGIN (dB)	ANTENNA HEIGHT (m)	TABLE ANGLE (Degree)	RAW VALUE (dBuV)	CORRECTION FACTOR (dB/m)
1	2390.00	61.9 PK	74.0	-12.1	2.10 V	342	31.0	30.9
2	2390.00	49.7 AV	54.0	-4.3	2.10 V	342	18.8	30.9
3	*2412.00	107.2 PK			2.93 V	353	76.1	31.1
4	*2412.00	96.8 AV			2.93 V	353	65.7	31.1
5	4824.00	48.6 PK	74.0	-25.4	1.30 V	324	44.1	4.5
6	4824.00	35.2 AV	54.0	-18.8	1.30 V	324	30.7	4.5

Remarks:

1. Emission Level(dBuV/m) = Raw Value(dBuV) + Correction Factor(dB/m)
2. Correction Factor(dB/m) = Antenna Factor(dB/m) + Cable Factor(dB) – Pre-Amplifier Factor(dB)
3. The other emission levels were very low against the limit.
4. Margin value = Emission Level – Limit value
5. " * ": Fundamental frequency.

CHANNEL	TX Channel 6	DETECTOR FUNCTION	Peak (PK)
FREQUENCY RANGE	1GHz ~ 25GHz		Average (AV)

ANTENNA POLARITY & TEST DISTANCE: HORIZONTAL AT 3 M

NO.	FREQ. (MHz)	EMISSION LEVEL (dBuV/m)	LIMIT (dBuV/m)	MARGIN (dB)	ANTENNA HEIGHT (m)	TABLE ANGLE (Degree)	RAW VALUE (dBuV)	CORRECTION FACTOR (dB/m)
1	*2437.00	111.9 PK			1.59 H	30	80.8	31.1
2	*2437.00	102.8 AV			1.59 H	30	71.7	31.1
3	2483.50	63.9 PK	74.0	-10.1	1.24 H	298	32.6	31.3
4	2483.50	51.1 AV	54.0	-2.9	1.24 H	298	19.8	31.3
5	4874.00	57.8 PK	74.0	-16.2	2.73 H	335	53.2	4.6
6	4874.00	44.2 AV	54.0	-9.8	2.73 H	335	39.6	4.6

ANTENNA POLARITY & TEST DISTANCE: VERTICAL AT 3 M

NO.	FREQ. (MHz)	EMISSION LEVEL (dBuV/m)	LIMIT (dBuV/m)	MARGIN (dB)	ANTENNA HEIGHT (m)	TABLE ANGLE (Degree)	RAW VALUE (dBuV)	CORRECTION FACTOR (dB/m)
1	*2437.00	113.7 PK			3.18 V	352	82.6	31.1
2	*2437.00	103.0 AV			3.18 V	352	71.9	31.1
3	2483.50	68.2 PK	74.0	-5.8	2.27 V	347	36.9	31.3
4	2483.50	52.5 AV	54.0	-1.5	2.27 V	347	21.2	31.3
5	4874.00	58.2 PK	74.0	-15.8	1.27 V	320	53.6	4.6
6	4874.00	45.2 AV	54.0	-8.8	1.27 V	320	40.6	4.6

Remarks:

1. Emission Level(dBuV/m) = Raw Value(dBuV) + Correction Factor(dB/m)
2. Correction Factor(dB/m) = Antenna Factor(dB/m) + Cable Factor(dB) – Pre-Amplifier Factor(dB)
3. The other emission levels were very low against the limit.
4. Margin value = Emission Level – Limit value
5. " * ": Fundamental frequency.

CHANNEL	TX Channel 11	DETECTOR FUNCTION	Peak (PK)
FREQUENCY RANGE	1GHz ~ 25GHz		Average (AV)

ANTENNA POLARITY & TEST DISTANCE: HORIZONTAL AT 3 M

NO.	FREQ. (MHz)	EMISSION LEVEL (dBuV/m)	LIMIT (dBuV/m)	MARGIN (dB)	ANTENNA HEIGHT (m)	TABLE ANGLE (Degree)	RAW VALUE (dBuV)	CORRECTION FACTOR (dB/m)
1	*2462.00	108.3 PK			1.45 H	293	77.1	31.2
2	*2462.00	98.0 AV			1.45 H	293	66.8	31.2
3	2483.50	70.0 PK	74.0	-4.0	1.17 H	313	38.7	31.3
4	2483.50	52.6 AV	54.0	-1.4	1.17 H	313	21.3	31.3
5	4924.00	49.7 PK	74.0	-24.3	2.13 H	355	45.2	4.5
6	4924.00	36.2 AV	54.0	-17.8	2.13 H	355	31.7	4.5

ANTENNA POLARITY & TEST DISTANCE: VERTICAL AT 3 M

NO.	FREQ. (MHz)	EMISSION LEVEL (dBuV/m)	LIMIT (dBuV/m)	MARGIN (dB)	ANTENNA HEIGHT (m)	TABLE ANGLE (Degree)	RAW VALUE (dBuV)	CORRECTION FACTOR (dB/m)
1	*2462.00	107.3 PK			2.76 V	350	76.1	31.2
2	*2462.00	97.3 AV			2.76 V	350	66.1	31.2
3	2483.50	66.0 PK	74.0	-8.0	2.80 V	349	34.7	31.3
4	2483.50	49.3 AV	54.0	-4.7	2.80 V	349	18.0	31.3
5	4924.00	48.2 PK	74.0	-25.8	1.26 V	321	43.7	4.5
6	4924.00	35.2 AV	54.0	-18.8	1.26 V	321	30.7	4.5

Remarks:

1. Emission Level(dBuV/m) = Raw Value(dBuV) + Correction Factor(dB/m)
2. Correction Factor(dB/m) = Antenna Factor(dB/m) + Cable Factor(dB) – Pre-Amplifier Factor(dB)
3. The other emission levels were very low against the limit.
4. Margin value = Emission Level – Limit value
5. " * ": Fundamental frequency.

802.11n (HT40)

CHANNEL	TX Channel 3	DETECTOR FUNCTION	Peak (PK)
FREQUENCY RANGE	1GHz ~ 25GHz		Average (AV)

ANTENNA POLARITY & TEST DISTANCE: HORIZONTAL AT 3 M

NO.	FREQ. (MHz)	EMISSION LEVEL (dBuV/m)	LIMIT (dBuV/m)	MARGIN (dB)	ANTENNA HEIGHT (m)	TABLE ANGLE (Degree)	RAW VALUE (dBuV)	CORRECTION FACTOR (dB/m)
1	2390.00	66.6 PK	74.0	-7.4	1.24 H	345	35.7	30.9
2	2390.00	51.7 AV	54.0	-2.3	1.24 H	345	20.8	30.9
3	*2422.00	105.0 PK			1.87 H	304	73.9	31.1
4	*2422.00	95.3 AV			1.87 H	304	64.2	31.1
5	4844.00	48.8 PK	74.0	-25.2	2.03 H	301	44.4	4.4
6	4844.00	35.9 AV	54.0	-18.1	2.03 H	301	31.5	4.4

ANTENNA POLARITY & TEST DISTANCE: VERTICAL AT 3 M

NO.	FREQ. (MHz)	EMISSION LEVEL (dBuV/m)	LIMIT (dBuV/m)	MARGIN (dB)	ANTENNA HEIGHT (m)	TABLE ANGLE (Degree)	RAW VALUE (dBuV)	CORRECTION FACTOR (dB/m)
1	2390.00	68.7 PK	74.0	-5.3	3.27 V	359	37.8	30.9
2	2390.00	52.3 AV	54.0	-1.7	3.27 V	359	21.4	30.9
3	*2422.00	104.1 PK			3.02 V	357	73.0	31.1
4	*2422.00	94.8 AV			3.02 V	357	63.7	31.1
5	4844.00	46.4 PK	74.0	-27.6	1.15 V	317	42.0	4.4
6	4844.00	34.5 AV	54.0	-19.5	1.15 V	317	30.1	4.4

Remarks:

1. Emission Level(dBuV/m) = Raw Value(dBuV) + Correction Factor(dB/m)
2. Correction Factor(dB/m) = Antenna Factor(dB/m) + Cable Factor(dB) – Pre-Amplifier Factor(dB)
3. The other emission levels were very low against the limit.
4. Margin value = Emission Level – Limit value
5. " * ": Fundamental frequency.

CHANNEL	TX Channel 6	DETECTOR FUNCTION	Peak (PK)
FREQUENCY RANGE	1GHz ~ 25GHz		Average (AV)

ANTENNA POLARITY & TEST DISTANCE: HORIZONTAL AT 3 M								
NO.	FREQ. (MHz)	EMISSION LEVEL (dBuV/m)	LIMIT (dBuV/m)	MARGIN (dB)	ANTENNA HEIGHT (m)	TABLE ANGLE (Degree)	RAW VALUE (dBuV)	CORRECTION FACTOR (dB/m)
1	2390.00	64.8 PK	74.0	-9.2	1.25 H	295	33.9	30.9
2	2390.00	49.7 AV	54.0	-4.3	1.25 H	295	18.8	30.9
3	*2437.00	103.8 PK			2.05 H	305	72.7	31.1
4	*2437.00	94.8 AV			2.05 H	305	63.7	31.1
5	2483.50	63.0 PK	74.0	-11.0	1.25 H	15	31.7	31.3
6	2483.50	51.1 AV	54.0	-2.9	1.25 H	15	19.8	31.3
7	4874.00	48.7 PK	74.0	-25.3	1.77 H	352	44.1	4.6
8	4874.00	35.9 AV	54.0	-18.1	1.77 H	352	31.3	4.6

ANTENNA POLARITY & TEST DISTANCE: VERTICAL AT 3 M								
NO.	FREQ. (MHz)	EMISSION LEVEL (dBuV/m)	LIMIT (dBuV/m)	MARGIN (dB)	ANTENNA HEIGHT (m)	TABLE ANGLE (Degree)	RAW VALUE (dBuV)	CORRECTION FACTOR (dB/m)
1	2390.00	62.3 PK	74.0	-11.7	2.71 V	3	31.4	30.9
2	2390.00	48.3 AV	54.0	-5.7	2.71 V	3	17.4	30.9
3	*2437.00	105.3 PK			3.13 V	3	74.2	31.1
4	*2437.00	96.0 AV			3.13 V	3	64.9	31.1
5	2483.50	66.5 PK	74.0	-7.5	2.79 V	352	35.2	31.3
6	2483.50	52.2 AV	54.0	-1.8	2.79 V	352	20.9	31.3
7	4874.00	49.0 PK	74.0	-25.0	1.33 V	319	44.4	4.6
8	4874.00	36.2 AV	54.0	-17.8	1.33 V	319	31.6	4.6

Remarks:

1. Emission Level(dBuV/m) = Raw Value(dBuV) + Correction Factor(dB/m)
2. Correction Factor(dB/m) = Antenna Factor(dB/m) + Cable Factor(dB) – Pre-Amplifier Factor(dB)
3. The other emission levels were very low against the limit.
4. Margin value = Emission Level – Limit value
5. " * ": Fundamental frequency.

CHANNEL	TX Channel 9	DETECTOR FUNCTION	Peak (PK)
FREQUENCY RANGE	1GHz ~ 25GHz		Average (AV)

ANTENNA POLARITY & TEST DISTANCE: HORIZONTAL AT 3 M								
NO.	FREQ. (MHz)	EMISSION LEVEL (dBuV/m)	LIMIT (dBuV/m)	MARGIN (dB)	ANTENNA HEIGHT (m)	TABLE ANGLE (Degree)	RAW VALUE (dBuV)	CORRECTION FACTOR (dB/m)
1	*2452.00	103.6 PK			1.83 H	288	72.4	31.2
2	*2452.00	94.3 AV			1.83 H	288	63.1	31.2
3	2483.50	68.9 PK	74.0	-5.1	1.16 H	294	37.6	31.3
4	2483.50	49.9 AV	54.0	-4.1	1.16 H	294	18.6	31.3
5	4904.00	49.3 PK	74.0	-24.7	1.99 H	303	44.8	4.5
6	4904.00	36.3 AV	54.0	-17.7	1.99 H	303	31.8	4.5

ANTENNA POLARITY & TEST DISTANCE: VERTICAL AT 3 M								
NO.	FREQ. (MHz)	EMISSION LEVEL (dBuV/m)	LIMIT (dBuV/m)	MARGIN (dB)	ANTENNA HEIGHT (m)	TABLE ANGLE (Degree)	RAW VALUE (dBuV)	CORRECTION FACTOR (dB/m)
1	*2452.00	105.2 PK			3.03 V	353	74.0	31.2
2	*2452.00	95.9 AV			3.03 V	353	64.7	31.2
3	2483.50	70.6 PK	74.0	-3.4	2.79 V	354	39.3	31.3
4	2483.50	52.2 AV	54.0	-1.8	2.79 V	354	20.9	31.3
5	4904.00	48.2 PK	74.0	-25.8	1.33 V	330	43.7	4.5
6	4904.00	35.0 AV	54.0	-19.0	1.33 V	330	30.5	4.5

Remarks:

1. Emission Level(dBuV/m) = Raw Value(dBuV) + Correction Factor(dB/m)
2. Correction Factor(dB/m) = Antenna Factor(dB/m) + Cable Factor(dB) – Pre-Amplifier Factor(dB)
3. The other emission levels were very low against the limit.
4. Margin value = Emission Level – Limit value
5. " * ": Fundamental frequency.

Test Mode C

802.11b

CHANNEL	TX Channel 1	DETECTOR FUNCTION	Peak (PK)
FREQUENCY RANGE	1GHz ~ 25GHz		Average (AV)

ANTENNA POLARITY & TEST DISTANCE: HORIZONTAL AT 3 M

NO.	FREQ. (MHz)	EMISSION LEVEL (dBuV/m)	LIMIT (dBuV/m)	MARGIN (dB)	ANTENNA HEIGHT (m)	TABLE ANGLE (Degree)	RAW VALUE (dBuV)	CORRECTION FACTOR (dB/m)
1	2390.00	56.3 PK	74.0	-17.7	1.70 H	299	25.4	30.9
2	2390.00	46.0 AV	54.0	-8.0	1.70 H	299	15.1	30.9
3	*2412.00	107.4 PK			1.72 H	289	76.3	31.1
4	*2412.00	103.4 AV			1.72 H	289	72.3	31.1
5	4824.00	48.3 PK	74.0	-25.7	1.70 H	312	43.8	4.5
6	4824.00	39.9 AV	54.0	-14.1	1.70 H	312	35.4	4.5

ANTENNA POLARITY & TEST DISTANCE: VERTICAL AT 3 M

NO.	FREQ. (MHz)	EMISSION LEVEL (dBuV/m)	LIMIT (dBuV/m)	MARGIN (dB)	ANTENNA HEIGHT (m)	TABLE ANGLE (Degree)	RAW VALUE (dBuV)	CORRECTION FACTOR (dB/m)
1	2390.00	59.2 PK	74.0	-14.8	1.94 V	348	28.3	30.9
2	2390.00	52.2 AV	54.0	-1.8	1.94 V	348	21.3	30.9
3	*2412.00	116.5 PK			1.54 V	330	85.4	31.1
4	*2412.00	112.6 AV			1.54 V	330	81.5	31.1
5	4824.00	47.2 PK	74.0	-26.8	1.78 V	305	42.7	4.5
6	4824.00	38.9 AV	54.0	-15.1	1.78 V	305	34.4	4.5

Remarks:

1. Emission Level(dBuV/m) = Raw Value(dBuV) + Correction Factor(dB/m)
2. Correction Factor(dB/m) = Antenna Factor(dB/m) + Cable Factor(dB) – Pre-Amplifier Factor(dB)
3. The other emission levels were very low against the limit.
4. Margin value = Emission Level – Limit value
5. " * ": Fundamental frequency.

CHANNEL	TX Channel 6	DETECTOR FUNCTION	Peak (PK)
FREQUENCY RANGE	1GHz ~ 25GHz		Average (AV)

ANTENNA POLARITY & TEST DISTANCE: HORIZONTAL AT 3 M

NO.	FREQ. (MHz)	EMISSION LEVEL (dBuV/m)	LIMIT (dBuV/m)	MARGIN (dB)	ANTENNA HEIGHT (m)	TABLE ANGLE (Degree)	RAW VALUE (dBuV)	CORRECTION FACTOR (dB/m)
1	2390.00	55.3 PK	74.0	-18.7	1.69 H	295	24.4	30.9
2	2390.00	45.2 AV	54.0	-8.8	1.69 H	295	14.3	30.9
3	*2437.00	110.5 PK			1.87 H	292	79.4	31.1
4	*2437.00	106.7 AV			1.87 H	292	75.6	31.1
5	2483.50	56.4 PK	74.0	-17.6	1.47 H	284	25.1	31.3
6	2483.50	45.8 AV	54.0	-8.2	1.47 H	284	14.5	31.3
7	4874.00	51.9 PK	74.0	-22.1	2.01 H	28	47.3	4.6
8	4874.00	47.1 AV	54.0	-6.9	2.01 H	28	42.5	4.6

ANTENNA POLARITY & TEST DISTANCE: VERTICAL AT 3 M

NO.	FREQ. (MHz)	EMISSION LEVEL (dBuV/m)	LIMIT (dBuV/m)	MARGIN (dB)	ANTENNA HEIGHT (m)	TABLE ANGLE (Degree)	RAW VALUE (dBuV)	CORRECTION FACTOR (dB/m)
1	2390.00	59.9 PK	74.0	-14.1	1.85 V	316	29.0	30.9
2	2390.00	52.7 AV	54.0	-1.3	1.85 V	316	21.8	30.9
3	*2437.00	118.4 PK			1.91 V	349	87.3	31.1
4	*2437.00	114.5 AV			1.91 V	349	83.4	31.1
5	2483.50	59.9 PK	74.0	-14.1	2.00 V	342	28.6	31.3
6	2483.50	52.3 AV	54.0	-1.7	2.00 V	342	21.0	31.3
7	4874.00	51.8 PK	74.0	-22.2	3.02 V	275	47.2	4.6
8	4874.00	46.4 AV	54.0	-7.6	3.02 V	275	41.8	4.6

Remarks:

1. Emission Level(dBuV/m) = Raw Value(dBuV) + Correction Factor(dB/m)
2. Correction Factor(dB/m) = Antenna Factor(dB/m) + Cable Factor(dB) – Pre-Amplifier Factor(dB)
3. The other emission levels were very low against the limit.
4. Margin value = Emission Level – Limit value
5. " * ": Fundamental frequency.

CHANNEL	TX Channel 11	DETECTOR FUNCTION	Peak (PK)
FREQUENCY RANGE	1GHz ~ 25GHz		Average (AV)

ANTENNA POLARITY & TEST DISTANCE: HORIZONTAL AT 3 M								
NO.	FREQ. (MHz)	EMISSION LEVEL (dBuV/m)	LIMIT (dBuV/m)	MARGIN (dB)	ANTENNA HEIGHT (m)	TABLE ANGLE (Degree)	RAW VALUE (dBuV)	CORRECTION FACTOR (dB/m)
1	*2462.00	107.3 PK			1.47 H	216	76.1	31.2
2	*2462.00	103.8 AV			1.47 H	216	72.6	31.2
3	2483.50	55.7 PK	74.0	-18.3	1.46 H	221	24.4	31.3
4	2483.50	45.0 AV	54.0	-9.0	1.46 H	221	13.7	31.3
5	4924.00	48.8 PK	74.0	-25.2	1.68 H	26	44.3	4.5
6	4924.00	42.2 AV	54.0	-11.8	1.68 H	26	37.7	4.5

ANTENNA POLARITY & TEST DISTANCE: VERTICAL AT 3 M								
NO.	FREQ. (MHz)	EMISSION LEVEL (dBuV/m)	LIMIT (dBuV/m)	MARGIN (dB)	ANTENNA HEIGHT (m)	TABLE ANGLE (Degree)	RAW VALUE (dBuV)	CORRECTION FACTOR (dB/m)
1	*2462.00	114.9 PK			1.50 V	318	83.7	31.2
2	*2462.00	111.1 AV			1.50 V	318	79.9	31.2
3	2483.50	61.4 PK	74.0	-12.6	1.67 V	355	30.1	31.3
4	2483.50	52.2 AV	54.0	-1.8	1.67 V	355	20.9	31.3
5	4924.00	48.1 PK	74.0	-25.9	1.54 V	313	43.6	4.5
6	4924.00	36.7 AV	54.0	-17.3	1.54 V	313	32.2	4.5

Remarks:

1. Emission Level(dBuV/m) = Raw Value(dBuV) + Correction Factor(dB/m)
2. Correction Factor(dB/m) = Antenna Factor(dB/m) + Cable Factor(dB) – Pre-Amplifier Factor(dB)
3. The other emission levels were very low against the limit.
4. Margin value = Emission Level – Limit value
5. " * ": Fundamental frequency.

802.11g

CHANNEL	TX Channel 1	DETECTOR FUNCTION	Peak (PK) Average (AV)
FREQUENCY RANGE	1GHz ~ 25GHz		

ANTENNA POLARITY & TEST DISTANCE: HORIZONTAL AT 3 M

NO.	FREQ. (MHz)	EMISSION LEVEL (dBuV/m)	LIMIT (dBuV/m)	MARGIN (dB)	ANTENNA HEIGHT (m)	TABLE ANGLE (Degree)	RAW VALUE (dBuV)	CORRECTION FACTOR (dB/m)
1	2390.00	58.8 PK	74.0	-15.2	1.44 H	129	27.9	30.9
2	2390.00	45.6 AV	54.0	-8.4	1.44 H	129	14.7	30.9
3	*2412.00	104.0 PK			1.50 H	125	72.9	31.1
4	*2412.00	93.8 AV			1.50 H	125	62.7	31.1
5	4824.00	45.5 PK	74.0	-28.5	1.98 H	6	41.0	4.5
6	4824.00	32.8 AV	54.0	-21.2	1.98 H	6	28.3	4.5

ANTENNA POLARITY & TEST DISTANCE: VERTICAL AT 3 M

NO.	FREQ. (MHz)	EMISSION LEVEL (dBuV/m)	LIMIT (dBuV/m)	MARGIN (dB)	ANTENNA HEIGHT (m)	TABLE ANGLE (Degree)	RAW VALUE (dBuV)	CORRECTION FACTOR (dB/m)
1	2390.00	68.4 PK	74.0	-5.6	1.94 V	352	37.5	30.9
2	2390.00	52.2 AV	54.0	-1.8	1.94 V	352	21.3	30.9
3	*2412.00	113.9 PK			1.76 V	356	82.8	31.1
4	*2412.00	103.0 AV			1.76 V	356	71.9	31.1
5	4824.00	45.7 PK	74.0	-28.3	1.32 V	86	41.2	4.5
6	4824.00	33.0 AV	54.0	-21.0	1.32 V	86	28.5	4.5

Remarks:

1. Emission Level(dBuV/m) = Raw Value(dBuV) + Correction Factor(dB/m)
2. Correction Factor(dB/m) = Antenna Factor(dB/m) + Cable Factor(dB) – Pre-Amplifier Factor(dB)
3. The other emission levels were very low against the limit.
4. Margin value = Emission Level – Limit value
5. " * ": Fundamental frequency.

CHANNEL	TX Channel 6	DETECTOR FUNCTION	Peak (PK)
FREQUENCY RANGE	1GHz ~ 25GHz		Average (AV)

ANTENNA POLARITY & TEST DISTANCE: HORIZONTAL AT 3 M

NO.	FREQ. (MHz)	EMISSION LEVEL (dBuV/m)	LIMIT (dBuV/m)	MARGIN (dB)	ANTENNA HEIGHT (m)	TABLE ANGLE (Degree)	RAW VALUE (dBuV)	CORRECTION FACTOR (dB/m)
1	2390.00	58.6 PK	74.0	-15.4	1.54 H	221	27.7	30.9
2	2390.00	45.0 AV	54.0	-9.0	1.54 H	221	14.1	30.9
3	*2437.00	109.5 PK			1.48 H	216	78.4	31.1
4	*2437.00	99.4 AV			1.48 H	216	68.3	31.1
5	2483.50	60.5 PK	74.0	-13.5	1.45 H	219	29.2	31.3
6	2483.50	46.2 AV	54.0	-7.8	1.45 H	219	14.9	31.3
7	4874.00	47.3 PK	74.0	-26.7	1.69 H	22	42.7	4.6
8	4874.00	34.9 AV	54.0	-19.1	1.69 H	22	30.3	4.6

ANTENNA POLARITY & TEST DISTANCE: VERTICAL AT 3 M

NO.	FREQ. (MHz)	EMISSION LEVEL (dBuV/m)	LIMIT (dBuV/m)	MARGIN (dB)	ANTENNA HEIGHT (m)	TABLE ANGLE (Degree)	RAW VALUE (dBuV)	CORRECTION FACTOR (dB/m)
1	2390.00	66.9 PK	74.0	-7.1	1.85 V	312	36.0	30.9
2	2390.00	52.6 AV	54.0	-1.4	1.85 V	312	21.7	30.9
3	*2437.00	118.3 PK			1.92 V	348	87.2	31.1
4	*2437.00	107.7 AV			1.92 V	348	76.6	31.1
5	2483.50	68.8 PK	74.0	-5.2	2.01 V	348	37.5	31.3
6	2483.50	52.3 AV	54.0	-1.7	2.01 V	348	21.0	31.3
7	4874.00	46.4 PK	74.0	-27.6	1.55 V	321	41.8	4.6
8	4874.00	33.8 AV	54.0	-20.2	1.55 V	321	29.2	4.6

Remarks:

1. Emission Level(dBuV/m) = Raw Value(dBuV) + Correction Factor(dB/m)
2. Correction Factor(dB/m) = Antenna Factor(dB/m) + Cable Factor(dB) – Pre-Amplifier Factor(dB)
3. The other emission levels were very low against the limit.
4. Margin value = Emission Level – Limit value
5. " * ": Fundamental frequency.

CHANNEL	TX Channel 11	DETECTOR FUNCTION	Peak (PK)
FREQUENCY RANGE	1GHz ~ 25GHz		Average (AV)

ANTENNA POLARITY & TEST DISTANCE: HORIZONTAL AT 3 M

NO.	FREQ. (MHz)	EMISSION LEVEL (dBuV/m)	LIMIT (dBuV/m)	MARGIN (dB)	ANTENNA HEIGHT (m)	TABLE ANGLE (Degree)	RAW VALUE (dBuV)	CORRECTION FACTOR (dB/m)
1	*2462.00	104.5 PK			1.42 H	182	73.3	31.2
2	*2462.00	94.0 AV			1.42 H	182	62.8	31.2
3	2483.50	63.0 PK	74.0	-11.0	1.40 H	183	31.7	31.3
4	2483.50	47.7 AV	54.0	-6.3	1.40 H	183	16.4	31.3
5	4924.00	45.2 PK	74.0	-28.8	1.53 H	119	40.7	4.5
6	4924.00	32.8 AV	54.0	-21.2	1.53 H	119	28.3	4.5

ANTENNA POLARITY & TEST DISTANCE: VERTICAL AT 3 M

NO.	FREQ. (MHz)	EMISSION LEVEL (dBuV/m)	LIMIT (dBuV/m)	MARGIN (dB)	ANTENNA HEIGHT (m)	TABLE ANGLE (Degree)	RAW VALUE (dBuV)	CORRECTION FACTOR (dB/m)
1	*2462.00	112.0 PK			1.47 V	351	80.8	31.2
2	*2462.00	101.9 AV			1.47 V	351	70.7	31.2
3	2483.50	68.2 PK	74.0	-5.8	2.02 V	349	36.9	31.3
4	2483.50	52.2 AV	54.0	-1.8	2.02 V	349	20.9	31.3
5	4924.00	45.5 PK	74.0	-28.5	1.64 V	231	41.0	4.5
6	4924.00	32.9 AV	54.0	-21.1	1.64 V	231	28.4	4.5

Remarks:

1. Emission Level(dBuV/m) = Raw Value(dBuV) + Correction Factor(dB/m)
2. Correction Factor(dB/m) = Antenna Factor(dB/m) + Cable Factor(dB) – Pre-Amplifier Factor(dB)
3. The other emission levels were very low against the limit.
4. Margin value = Emission Level – Limit value
5. " * ": Fundamental frequency.

802.11n (HT20)

CHANNEL	TX Channel 1	DETECTOR FUNCTION	Peak (PK)
FREQUENCY RANGE	1GHz ~ 25GHz		Average (AV)

ANTENNA POLARITY & TEST DISTANCE: HORIZONTAL AT 3 M

NO.	FREQ. (MHz)	EMISSION LEVEL (dBuV/m)	LIMIT (dBuV/m)	MARGIN (dB)	ANTENNA HEIGHT (m)	TABLE ANGLE (Degree)	RAW VALUE (dBuV)	CORRECTION FACTOR (dB/m)
1	2390.00	57.9 PK	74.0	-16.1	1.46 H	161	27.0	30.9
2	2390.00	45.6 AV	54.0	-8.4	1.46 H	161	14.7	30.9
3	*2412.00	105.1 PK			1.44 H	126	74.0	31.1
4	*2412.00	94.3 AV			1.44 H	126	63.2	31.1
5	4824.00	45.1 PK	74.0	-28.9	1.54 H	20	40.6	4.5
6	4824.00	32.6 AV	54.0	-21.4	1.54 H	20	28.1	4.5

ANTENNA POLARITY & TEST DISTANCE: VERTICAL AT 3 M

NO.	FREQ. (MHz)	EMISSION LEVEL (dBuV/m)	LIMIT (dBuV/m)	MARGIN (dB)	ANTENNA HEIGHT (m)	TABLE ANGLE (Degree)	RAW VALUE (dBuV)	CORRECTION FACTOR (dB/m)
1	2390.00	67.6 PK	74.0	-6.4	1.95 V	347	36.7	30.9
2	2390.00	52.3 AV	54.0	-1.7	1.95 V	347	21.4	30.9
3	*2412.00	113.5 PK			1.75 V	355	82.4	31.1
4	*2412.00	103.2 AV			1.75 V	355	72.1	31.1
5	4824.00	45.1 PK	74.0	-28.9	1.66 V	311	40.6	4.5
6	4824.00	32.7 AV	54.0	-21.3	1.66 V	311	28.2	4.5

Remarks:

1. Emission Level(dBuV/m) = Raw Value(dBuV) + Correction Factor(dB/m)
2. Correction Factor(dB/m) = Antenna Factor(dB/m) + Cable Factor(dB) – Pre-Amplifier Factor(dB)
3. The other emission levels were very low against the limit.
4. Margin value = Emission Level – Limit value
5. " * ": Fundamental frequency.

CHANNEL	TX Channel 6	DETECTOR FUNCTION	Peak (PK)
FREQUENCY RANGE	1GHz ~ 25GHz		Average (AV)

ANTENNA POLARITY & TEST DISTANCE: HORIZONTAL AT 3 M

NO.	FREQ. (MHz)	EMISSION LEVEL (dBuV/m)	LIMIT (dBuV/m)	MARGIN (dB)	ANTENNA HEIGHT (m)	TABLE ANGLE (Degree)	RAW VALUE (dBuV)	CORRECTION FACTOR (dB/m)
1	2390.00	58.3 PK	74.0	-15.7	1.69 H	210	27.4	30.9
2	2390.00	44.7 AV	54.0	-9.3	1.69 H	210	13.8	30.9
3	*2437.00	108.8 PK			1.48 H	217	77.7	31.1
4	*2437.00	99.0 AV			1.48 H	217	67.9	31.1
5	2483.50	61.3 PK	74.0	-12.7	1.43 H	216	30.0	31.3
6	2483.50	45.3 AV	54.0	-8.7	1.43 H	216	14.0	31.3
7	4874.00	46.2 PK	74.0	-27.8	1.84 H	10	41.6	4.6
8	4874.00	33.7 AV	54.0	-20.3	1.84 H	10	29.1	4.6

ANTENNA POLARITY & TEST DISTANCE: VERTICAL AT 3 M

NO.	FREQ. (MHz)	EMISSION LEVEL (dBuV/m)	LIMIT (dBuV/m)	MARGIN (dB)	ANTENNA HEIGHT (m)	TABLE ANGLE (Degree)	RAW VALUE (dBuV)	CORRECTION FACTOR (dB/m)
1	2390.00	70.9 PK	74.0	-3.1	1.85 V	315	40.0	30.9
2	2390.00	52.8 AV	54.0	-1.2	1.85 V	315	21.9	30.9
3	*2437.00	117.6 PK			1.51 V	342	86.5	31.1
4	*2437.00	107.1 AV			1.51 V	342	76.0	31.1
5	2483.50	70.9 PK	74.0	-3.1	2.01 V	351	39.6	31.3
6	2483.50	52.2 AV	54.0	-1.8	2.01 V	351	20.9	31.3
7	4874.00	46.3 PK	74.0	-27.7	1.63 V	301	41.7	4.6
8	4874.00	32.8 AV	54.0	-21.2	1.63 V	301	28.2	4.6

Remarks:

1. Emission Level(dBuV/m) = Raw Value(dBuV) + Correction Factor(dB/m)
2. Correction Factor(dB/m) = Antenna Factor(dB/m) + Cable Factor(dB) – Pre-Amplifier Factor(dB)
3. The other emission levels were very low against the limit.
4. Margin value = Emission Level – Limit value
5. " * ": Fundamental frequency.

CHANNEL	TX Channel 11	DETECTOR FUNCTION	Peak (PK)
FREQUENCY RANGE	1GHz ~ 25GHz		Average (AV)

ANTENNA POLARITY & TEST DISTANCE: HORIZONTAL AT 3 M								
NO.	FREQ. (MHz)	EMISSION LEVEL (dBuV/m)	LIMIT (dBuV/m)	MARGIN (dB)	ANTENNA HEIGHT (m)	TABLE ANGLE (Degree)	RAW VALUE (dBuV)	CORRECTION FACTOR (dB/m)
1	*2462.00	104.8 PK			1.63 H	180	73.6	31.2
2	*2462.00	94.4 AV			1.63 H	180	63.2	31.2
3	2483.50	64.3 PK	74.0	-9.7	1.62 H	179	33.0	31.3
4	2483.50	47.6 AV	54.0	-6.4	1.62 H	179	16.3	31.3
5	4924.00	46.0 PK	74.0	-28.0	1.71 H	111	41.5	4.5
6	4924.00	32.8 AV	54.0	-21.2	1.71 H	111	28.3	4.5
ANTENNA POLARITY & TEST DISTANCE: VERTICAL AT 3 M								
NO.	FREQ. (MHz)	EMISSION LEVEL (dBuV/m)	LIMIT (dBuV/m)	MARGIN (dB)	ANTENNA HEIGHT (m)	TABLE ANGLE (Degree)	RAW VALUE (dBuV)	CORRECTION FACTOR (dB/m)
1	*2462.00	112.7 PK			1.76 V	2	81.5	31.2
2	*2462.00	102.0 AV			1.76 V	2	70.8	31.2
3	2483.50	70.5 PK	74.0	-3.5	1.71 V	331	39.2	31.3
4	2483.50	52.5 AV	54.0	-1.5	1.71 V	331	21.2	31.3
5	4924.00	45.6 PK	74.0	-28.4	1.63 V	310	41.1	4.5
6	4924.00	32.7 AV	54.0	-21.3	1.63 V	310	28.2	4.5

Remarks:

1. Emission Level(dBuV/m) = Raw Value(dBuV) + Correction Factor(dB/m)
2. Correction Factor(dB/m) = Antenna Factor(dB/m) + Cable Factor(dB) – Pre-Amplifier Factor(dB)
3. The other emission levels were very low against the limit.
4. Margin value = Emission Level – Limit value
5. " * ": Fundamental frequency.

802.11n (HT40)

CHANNEL	TX Channel 3	DETECTOR FUNCTION	Peak (PK)
FREQUENCY RANGE	1GHz ~ 25GHz		Average (AV)

ANTENNA POLARITY & TEST DISTANCE: HORIZONTAL AT 3 M

NO.	FREQ. (MHz)	EMISSION LEVEL (dBuV/m)	LIMIT (dBuV/m)	MARGIN (dB)	ANTENNA HEIGHT (m)	TABLE ANGLE (Degree)	RAW VALUE (dBuV)	CORRECTION FACTOR (dB/m)
1	2390.00	58.6 PK	74.0	-15.4	1.33 H	172	27.7	30.9
2	2390.00	45.8 AV	54.0	-8.2	1.33 H	172	14.9	30.9
3	*2422.00	100.3 PK			1.67 H	174	69.2	31.1
4	*2422.00	90.8 AV			1.67 H	174	59.7	31.1
5	4844.00	44.6 PK	74.0	-29.4	1.43 H	115	40.2	4.4
6	4844.00	31.9 AV	54.0	-22.1	1.43 H	115	27.5	4.4

ANTENNA POLARITY & TEST DISTANCE: VERTICAL AT 3 M

NO.	FREQ. (MHz)	EMISSION LEVEL (dBuV/m)	LIMIT (dBuV/m)	MARGIN (dB)	ANTENNA HEIGHT (m)	TABLE ANGLE (Degree)	RAW VALUE (dBuV)	CORRECTION FACTOR (dB/m)
1	2390.00	68.3 PK	74.0	-5.7	1.82 V	320	37.4	30.9
2	2390.00	52.7 AV	54.0	-1.3	1.82 V	320	21.8	30.9
3	*2422.00	108.7 PK			1.34 V	347	77.6	31.1
4	*2422.00	99.0 AV			1.34 V	347	67.9	31.1
5	4844.00	45.0 PK	74.0	-29.0	1.38 V	256	40.6	4.4
6	4844.00	32.3 AV	54.0	-21.7	1.38 V	256	27.9	4.4

Remarks:

1. Emission Level(dBuV/m) = Raw Value(dBuV) + Correction Factor(dB/m)
2. Correction Factor(dB/m) = Antenna Factor(dB/m) + Cable Factor(dB) – Pre-Amplifier Factor(dB)
3. The other emission levels were very low against the limit.
4. Margin value = Emission Level – Limit value
5. " * " : Fundamental frequency.

CHANNEL	TX Channel 6	DETECTOR FUNCTION	Peak (PK)
FREQUENCY RANGE	1GHz ~ 25GHz		Average (AV)

ANTENNA POLARITY & TEST DISTANCE: HORIZONTAL AT 3 M								
NO.	FREQ. (MHz)	EMISSION LEVEL (dBuV/m)	LIMIT (dBuV/m)	MARGIN (dB)	ANTENNA HEIGHT (m)	TABLE ANGLE (Degree)	RAW VALUE (dBuV)	CORRECTION FACTOR (dB/m)
1	2390.00	56.8 PK	74.0	-17.2	1.49 H	217	25.9	30.9
2	2390.00	44.7 AV	54.0	-9.3	1.49 H	217	13.8	30.9
3	*2437.00	100.2 PK			1.50 H	219	69.1	31.1
4	*2437.00	91.2 AV			1.50 H	219	60.1	31.1
5	2483.50	58.3 PK	74.0	-15.7	1.78 H	222	27.0	31.3
6	2483.50	45.1 AV	54.0	-8.9	1.78 H	222	13.8	31.3
7	4874.00	45.3 PK	74.0	-28.7	1.64 H	152	40.7	4.6
8	4874.00	32.7 AV	54.0	-21.3	1.64 H	152	28.1	4.6

ANTENNA POLARITY & TEST DISTANCE: VERTICAL AT 3 M								
NO.	FREQ. (MHz)	EMISSION LEVEL (dBuV/m)	LIMIT (dBuV/m)	MARGIN (dB)	ANTENNA HEIGHT (m)	TABLE ANGLE (Degree)	RAW VALUE (dBuV)	CORRECTION FACTOR (dB/m)
1	2390.00	67.4 PK	74.0	-6.6	1.86 V	313	36.5	30.9
2	2390.00	52.2 AV	54.0	-1.8	1.86 V	313	21.3	30.9
3	*2437.00	109.4 PK			1.88 V	351	78.3	31.1
4	*2437.00	100.4 AV			1.88 V	351	69.3	31.1
5	2483.50	65.6 PK	74.0	-8.4	1.65 V	353	34.3	31.3
6	2483.50	51.7 AV	54.0	-2.3	1.65 V	353	20.4	31.3
7	4874.00	45.2 PK	74.0	-28.8	1.73 V	255	40.6	4.6
8	4874.00	32.5 AV	54.0	-21.5	1.73 V	255	27.9	4.6

Remarks:

1. Emission Level(dBuV/m) = Raw Value(dBuV) + Correction Factor(dB/m)
2. Correction Factor(dB/m) = Antenna Factor(dB/m) + Cable Factor(dB) – Pre-Amplifier Factor(dB)
3. The other emission levels were very low against the limit.
4. Margin value = Emission Level – Limit value
5. " * ": Fundamental frequency.

CHANNEL	TX Channel 9	DETECTOR FUNCTION	Peak (PK)
FREQUENCY RANGE	1GHz ~ 25GHz		Average (AV)

ANTENNA POLARITY & TEST DISTANCE: HORIZONTAL AT 3 M								
NO.	FREQ. (MHz)	EMISSION LEVEL (dBuV/m)	LIMIT (dBuV/m)	MARGIN (dB)	ANTENNA HEIGHT (m)	TABLE ANGLE (Degree)	RAW VALUE (dBuV)	CORRECTION FACTOR (dB/m)
1	*2452.00	101.0 PK			1.78 H	118	69.8	31.2
2	*2452.00	91.8 AV			1.78 H	118	60.6	31.2
3	2483.50	61.4 PK	74.0	-12.6	2.12 H	120	30.1	31.3
4	2483.50	45.8 AV	54.0	-8.2	2.12 H	120	14.5	31.3
5	4904.00	45.3 PK	74.0	-28.7	1.84 H	61	40.8	4.5
6	4904.00	32.1 AV	54.0	-21.9	1.84 H	61	27.6	4.5
ANTENNA POLARITY & TEST DISTANCE: VERTICAL AT 3 M								
NO.	FREQ. (MHz)	EMISSION LEVEL (dBuV/m)	LIMIT (dBuV/m)	MARGIN (dB)	ANTENNA HEIGHT (m)	TABLE ANGLE (Degree)	RAW VALUE (dBuV)	CORRECTION FACTOR (dB/m)
1	*2452.00	108.4 PK			2.29 V	350	77.2	31.2
2	*2452.00	99.1 AV			2.29 V	350	67.9	31.2
3	2483.50	69.8 PK	74.0	-4.2	1.97 V	350	38.5	31.3
4	2483.50	52.3 AV	54.0	-1.7	1.97 V	350	21.0	31.3
5	4904.00	45.0 PK	74.0	-29.0	1.92 V	253	40.5	4.5
6	4904.00	32.6 AV	54.0	-21.4	1.92 V	253	28.1	4.5

Remarks:

1. Emission Level(dBuV/m) = Raw Value(dBuV) + Correction Factor(dB/m)
2. Correction Factor(dB/m) = Antenna Factor(dB/m) + Cable Factor(dB) – Pre-Amplifier Factor(dB)
3. The other emission levels were very low against the limit.
4. Margin value = Emission Level – Limit value
5. " * ": Fundamental frequency.

Below 1GHz worst-case data:

802.11b

CHANNEL	TX Channel 1	DETECTOR FUNCTION	Quasi-Peak (QP)
FREQUENCY RANGE	9kHz ~ 1GHz		
TEST MODE	A		

ANTENNA POLARITY & TEST DISTANCE: HORIZONTAL AT 3 M

NO.	FREQ. (MHz)	EMISSION LEVEL (dBuV/m)	LIMIT (dBuV/m)	MARGIN (dB)	ANTENNA HEIGHT (m)	TABLE ANGLE (Degree)	RAW VALUE (dBuV)	CORRECTION FACTOR (dB/m)
1	57.12	26.7 QP	40.0	-13.3	2.00 H	290	41.2	-14.5
2	156.28	26.5 QP	43.5	-17.0	1.50 H	236	40.1	-13.6
3	360.43	36.8 QP	46.0	-9.2	1.01 H	73	47.6	-10.8
4	510.14	28.4 QP	46.0	-17.6	1.50 H	181	35.9	-7.5
5	722.07	30.7 QP	46.0	-15.3	1.01 H	14	33.9	-3.2
6	988.43	33.2 QP	54.0	-20.8	1.50 H	6	31.3	1.9

ANTENNA POLARITY & TEST DISTANCE: VERTICAL AT 3 M

NO.	FREQ. (MHz)	EMISSION LEVEL (dBuV/m)	LIMIT (dBuV/m)	MARGIN (dB)	ANTENNA HEIGHT (m)	TABLE ANGLE (Degree)	RAW VALUE (dBuV)	CORRECTION FACTOR (dB/m)
1	39.62	33.9 QP	40.0	-6.1	1.00 V	14	49.0	-15.1
2	121.28	28.2 QP	43.5	-15.3	1.50 V	6	44.2	-16.0
3	249.60	25.3 QP	46.0	-20.7	1.50 V	104	39.2	-13.9
4	362.37	37.2 QP	46.0	-8.8	1.00 V	189	48.0	-10.8
5	613.19	31.1 QP	46.0	-14.9	1.00 V	163	36.1	-5.0
6	906.77	31.6 QP	46.0	-14.4	1.50 V	6	31.0	0.6

Remarks:

1. Emission Level(dBuV/m) = Raw Value(dBuV) + Correction Factor(dB/m)
2. Correction Factor(dB/m) = Antenna Factor(dB/m) + Cable Factor(dB) – Pre-Amplifier Factor(dB)
3. The other emission levels were very low against the limit.
4. Margin value = Emission Level – Limit value

CHANNEL	TX Channel 1	DETECTOR FUNCTION	Quasi-Peak (QP)
FREQUENCY RANGE	9kHz ~ 1GHz		
TEST MODE	B		

ANTENNA POLARITY & TEST DISTANCE: HORIZONTAL AT 3 M

NO.	FREQ. (MHz)	EMISSION LEVEL (dBuV/m)	LIMIT (dBuV/m)	MARGIN (dB)	ANTENNA HEIGHT (m)	TABLE ANGLE (Degree)	RAW VALUE (dBuV)	CORRECTION FACTOR (dB/m)
1	78.51	34.5 QP	40.0	-5.5	1.00 H	275	52.7	-18.2
2	131.00	35.0 QP	43.5	-8.5	2.00 H	102	50.4	-15.4
3	358.48	39.5 QP	46.0	-6.5	1.00 H	265	50.3	-10.8
4	498.47	29.4 QP	46.0	-16.6	1.50 H	258	37.2	-7.8
5	644.30	28.5 QP	46.0	-17.5	1.00 H	310	32.9	-4.4
6	930.11	31.8 QP	46.0	-14.2	1.00 H	9	30.7	1.1

ANTENNA POLARITY & TEST DISTANCE: VERTICAL AT 3 M

NO.	FREQ. (MHz)	EMISSION LEVEL (dBuV/m)	LIMIT (dBuV/m)	MARGIN (dB)	ANTENNA HEIGHT (m)	TABLE ANGLE (Degree)	RAW VALUE (dBuV)	CORRECTION FACTOR (dB/m)
1	59.06	38.3 QP	40.0	-1.7	1.00 V	343	52.9	-14.6
2	79.87	36.0 QP	40.0	-4.0	2.00 V	186	54.5	-18.5
3	150.45	32.4 QP	43.5	-11.1	1.00 V	321	46.1	-13.7
4	360.43	36.5 QP	46.0	-9.5	1.49 V	269	47.3	-10.8
5	722.07	31.3 QP	46.0	-14.7	1.49 V	12	34.5	-3.2
6	984.55	32.7 QP	54.0	-21.3	1.99 V	12	30.9	1.8

Remarks:

1. Emission Level(dBuV/m) = Raw Value(dBuV) + Correction Factor(dB/m)
2. Correction Factor(dB/m) = Antenna Factor(dB/m) + Cable Factor(dB) – Pre-Amplifier Factor(dB)
3. The other emission levels were very low against the limit.
4. Margin value = Emission Level – Limit value

CHANNEL	TX Channel 1	DETECTOR FUNCTION	Quasi-Peak (QP)
FREQUENCY RANGE	9kHz ~ 1GHz		
TEST MODE	C		

ANTENNA POLARITY & TEST DISTANCE: HORIZONTAL AT 3 M

NO.	FREQ. (MHz)	EMISSION LEVEL (dBuV/m)	LIMIT (dBuV/m)	MARGIN (dB)	ANTENNA HEIGHT (m)	TABLE ANGLE (Degree)	RAW VALUE (dBuV)	CORRECTION FACTOR (dB/m)
1	57.12	28.0 QP	40.0	-12.0	2.00 H	302	42.5	-14.5
2	125.17	28.0 QP	43.5	-15.5	1.50 H	79	43.8	-15.8
3	206.83	26.0 QP	43.5	-17.5	1.01 H	138	41.9	-15.9
4	249.60	30.7 QP	46.0	-15.3	1.01 H	209	44.6	-13.9
5	315.71	32.1 QP	46.0	-13.9	1.01 H	199	43.6	-11.5
6	500.42	28.0 QP	46.0	-18.0	1.50 H	206	35.8	-7.8

ANTENNA POLARITY & TEST DISTANCE: VERTICAL AT 3 M

NO.	FREQ. (MHz)	EMISSION LEVEL (dBuV/m)	LIMIT (dBuV/m)	MARGIN (dB)	ANTENNA HEIGHT (m)	TABLE ANGLE (Degree)	RAW VALUE (dBuV)	CORRECTION FACTOR (dB/m)
1	43.51	35.5 QP	40.0	-4.5	1.01 V	44	50.1	-14.6
2	66.84	34.8 QP	40.0	-5.2	1.49 V	226	50.5	-15.7
3	173.78	29.9 QP	43.5	-13.6	1.01 V	138	43.9	-14.0
4	249.60	28.9 QP	46.0	-17.1	1.49 V	132	42.8	-13.9
5	315.71	28.4 QP	46.0	-17.6	1.49 V	302	39.9	-11.5
6	830.95	36.6 QP	46.0	-9.4	1.01 V	17	37.5	-0.9

Remarks:

1. Emission Level(dBuV/m) = Raw Value(dBuV) + Correction Factor(dB/m)
2. Correction Factor(dB/m) = Antenna Factor(dB/m) + Cable Factor(dB) – Pre-Amplifier Factor(dB)
3. The other emission levels were very low against the limit.
4. Margin value = Emission Level – Limit value

CHANNEL	TX Channel 1	DETECTOR FUNCTION	Quasi-Peak (QP)
FREQUENCY RANGE	9kHz ~ 1GHz		
TEST MODE	D		

ANTENNA POLARITY & TEST DISTANCE: HORIZONTAL AT 3 M

NO.	FREQ. (MHz)	EMISSION LEVEL (dBuV/m)	LIMIT (dBuV/m)	MARGIN (dB)	ANTENNA HEIGHT (m)	TABLE ANGLE (Degree)	RAW VALUE (dBuV)	CORRECTION FACTOR (dB/m)
1	78.51	36.6 QP	40.0	-3.4	1.01 H	270	54.8	-18.2
2	119.34	33.8 QP	43.5	-9.7	1.50 H	246	49.9	-16.1
3	173.78	30.5 QP	43.5	-13.0	1.50 H	234	44.5	-14.0
4	206.83	32.9 QP	43.5	-10.6	1.01 H	177	48.8	-15.9
5	337.10	35.7 QP	46.0	-10.3	1.01 H	144	46.9	-11.2
6	900.94	33.6 QP	46.0	-12.4	1.50 H	16	33.2	0.4

ANTENNA POLARITY & TEST DISTANCE: VERTICAL AT 3 M

NO.	FREQ. (MHz)	EMISSION LEVEL (dBuV/m)	LIMIT (dBuV/m)	MARGIN (dB)	ANTENNA HEIGHT (m)	TABLE ANGLE (Degree)	RAW VALUE (dBuV)	CORRECTION FACTOR (dB/m)
1	58.90	35.4 QP	40.0	-4.6	1.00 V	354	50.0	-14.6
2	74.83	37.9 QP	40.0	-2.1	1.00 V	159	55.0	-17.1
3	125.17	30.2 QP	43.5	-13.3	1.50 V	31	46.0	-15.8
4	206.83	28.1 QP	43.5	-15.4	1.50 V	143	44.0	-15.9
5	269.05	31.0 QP	46.0	-15.0	1.99 V	16	44.0	-13.0
6	339.04	35.1 QP	46.0	-10.9	1.50 V	155	46.2	-11.1

Remarks:

1. Emission Level(dBuV/m) = Raw Value(dBuV) + Correction Factor(dB/m)
2. Correction Factor(dB/m) = Antenna Factor(dB/m) + Cable Factor(dB) – Pre-Amplifier Factor(dB)
3. The other emission levels were very low against the limit.
4. Margin value = Emission Level – Limit value

4.2 Conducted Emission Measurement

4.2.1 Limits of Conducted Emission Measurement

Frequency (MHz)	Conducted Limit (dBuV)	
	Quasi-peak	Average
0.15 - 0.5	66 - 56	56 - 46
0.50 - 5.0	56	46
5.0 - 30.0	60	50

- Note:** 1. The lower limit shall apply at the transition frequencies.
 2. The limit decreases in line with the logarithm of the frequency in the range of 0.15 to 0.50MHz.

4.2.2 Test Instruments

Description & Manufacturer	Model No.	Serial No.	Cal. Date	Cal. Due
Test Receiver ROHDE & SCHWARZ	ESCS 30	100288	Aug. 18, 2016	Aug. 17, 2017
RF signal cable (with 10dB PAD) Woken	5D-FB	Cable-cond2-01	Dec. 22, 2015	Dec. 21, 2016
			Dec. 22, 2016	Dec. 21, 2017
LISN ROHDE & SCHWARZ (EUT)	ESH2-Z5	100100	Jan. 17, 2016	Jan. 16, 2017
			Jan. 17, 2017	Jan. 16, 2018
LISN ROHDE & SCHWARZ (Peripheral)	ESH3-Z5	100312	Jul. 26, 2016	Jul. 25, 2017
Software ADT	BV ADT_Cond_ V7.3.7.3	NA	NA	NA

- Note:** 1. The calibration interval of the above test instruments is 12 months and the calibrations are traceable to NML/ROC and NIST/USA.
 2. The test was performed in HwaYa Shielded Room 2.
 3. The VCCI Site Registration No. is C-2047.

4.2.3 Test Procedures

- The EUT was placed 0.4 meters from the conducting wall of the shielded room with EUT being connected to the power mains through a line impedance stabilization network (LISN). Other support units were connected to the power mains through another LISN. The two LISNs provide 50 ohm/ 50uH of coupling impedance for the measuring instrument.
- Both lines of the power mains connected to the EUT were checked for maximum conducted interference.
- The frequency range from 150kHz to 30MHz was searched. Emission levels under (Limit - 20dB) was not recorded.

Note: The resolution bandwidth and video bandwidth of test receiver is 9kHz for quasi-peak detection (QP) and average detection (AV) at frequency 0.15MHz-30MHz.

4.2.4 Deviation from Test Standard

No deviation.

4.2.5 Test Setup

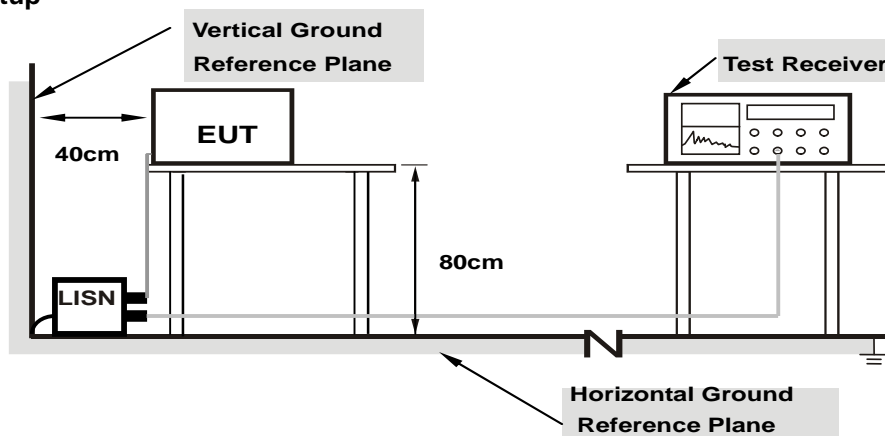

Note: 1.Support units were connected to second LISN.

For the actual test configuration, please refer to the attached file (Test Setup Photo).

4.2.6 EUT Operating Conditions

Same as 4.1.6.

4.2.7 Test Results

802.11b

Phase	Line (L)	Detector Function	Quasi-Peak (QP) / Average (AV)
Test Mode	A		

No	Freq. [MHz]	Corr. Factor (dB)	Reading Value [dB (uV)]		Emission Level [dB (uV)]		Limit [dB (uV)]		Margin (dB)	
			Q.P.	AV.	Q.P.	AV.	Q.P.	AV.	Q.P.	AV.
			1	0.15391	10.01	37.07	20.22	47.08	30.23	65.79
2	0.35313	10.03	36.40	30.21	46.43	40.24	58.89	48.89	-12.46	-8.65
3	0.54063	10.05	12.57	6.12	22.62	16.17	56.00	46.00	-33.38	-29.83
4	4.53125	10.15	12.94	5.82	23.09	15.97	56.00	46.00	-32.91	-30.03
5	8.73438	10.26	12.44	7.38	22.70	17.64	60.00	50.00	-37.30	-32.36
6	13.26563	10.35	9.71	4.36	20.06	14.71	60.00	50.00	-39.94	-35.29

Remarks:

1. Q.P. and AV. are abbreviations of quasi-peak and average individually.
2. The emission levels of other frequencies were very low against the limit.
3. Margin value = Emission level - Limit value
4. Correction factor = Insertion loss + Cable loss
5. Emission Level = Correction Factor + Reading Value.

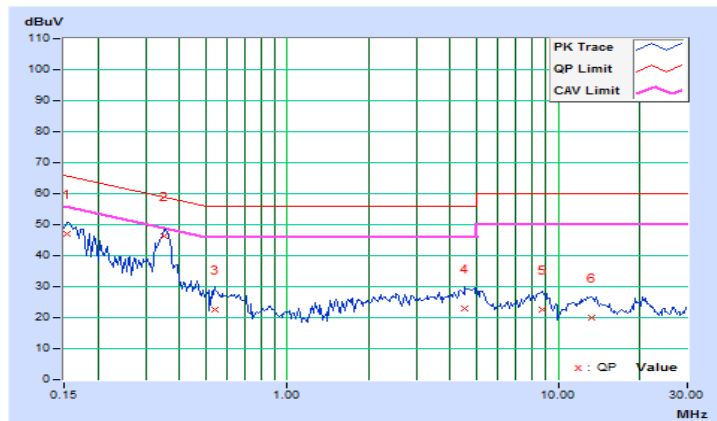

Phase	Neutral (N)	Detector Function	Quasi-Peak (QP) / Average (AV)
Test Mode	A		

No	Freq. [MHz]	Corr. Factor (dB)	Reading Value [dB (uV)]		Emission Level [dB (uV)]		Limit [dB (uV)]		Margin (dB)	
			Q.P.	AV.	Q.P.	AV.	Q.P.	AV.	Q.P.	AV.
			1	0.15781	10.01	36.13	18.95	46.14	28.96	65.58
2	0.19297	9.98	32.85	21.76	42.83	31.74	63.91	53.91	-21.08	-22.17
3	0.35703	10.02	34.60	29.39	44.62	39.41	58.80	48.80	-14.18	-9.39
4	4.86719	10.26	13.95	6.48	24.21	16.74	56.00	46.00	-31.79	-29.26
5	13.28906	10.43	10.03	4.84	20.46	15.27	60.00	50.00	-39.54	-34.73
6	20.73828	10.68	8.89	3.37	19.57	14.05	60.00	50.00	-40.43	-35.95

Remarks:

1. Q.P. and AV. are abbreviations of quasi-peak and average individually.
2. The emission levels of other frequencies were very low against the limit.
3. Margin value = Emission level - Limit value
4. Correction factor = Insertion loss + Cable loss
5. Emission Level = Correction Factor + Reading Value.

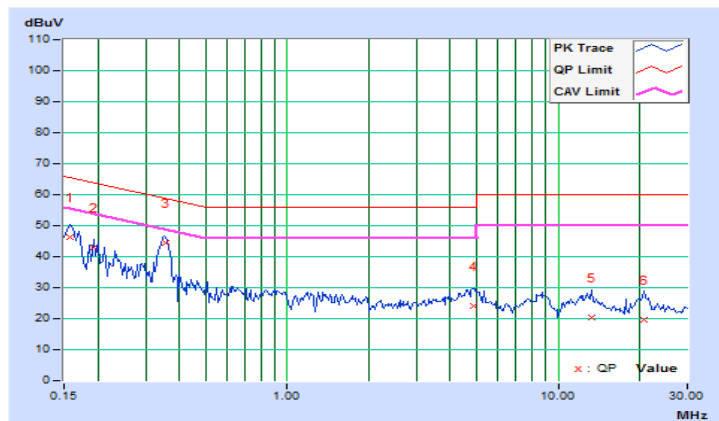

Phase	Line (L)	Detector Function	Quasi-Peak (QP) / Average (AV)
Test Mode	B		

No	Freq. [MHz]	Corr. Factor (dB)	Reading Value [dB (uV)]		Emission Level [dB (uV)]		Limit [dB (uV)]		Margin (dB)	
			Q.P.	AV.	Q.P.	AV.	Q.P.	AV.	Q.P.	AV.
			1	0.15781	10.01	35.12	20.96	45.13	30.97	65.58
2	0.18125	10.02	31.28	16.39	41.30	26.41	64.43	54.43	-23.13	-28.02
3	0.51328	10.05	37.21	32.88	47.26	42.93	56.00	46.00	-8.74	-3.07
4	0.64219	10.06	25.73	21.27	35.79	31.33	56.00	46.00	-20.21	-14.67
5	3.48438	10.13	25.33	20.27	35.46	30.40	56.00	46.00	-20.54	-15.60
6	11.93359	10.33	29.30	24.66	39.63	34.99	60.00	50.00	-20.37	-15.01

Remarks:

1. Q.P. and AV. are abbreviations of quasi-peak and average individually.
2. The emission levels of other frequencies were very low against the limit.
3. Margin value = Emission level - Limit value
4. Correction factor = Insertion loss + Cable loss
5. Emission Level = Correction Factor + Reading Value.

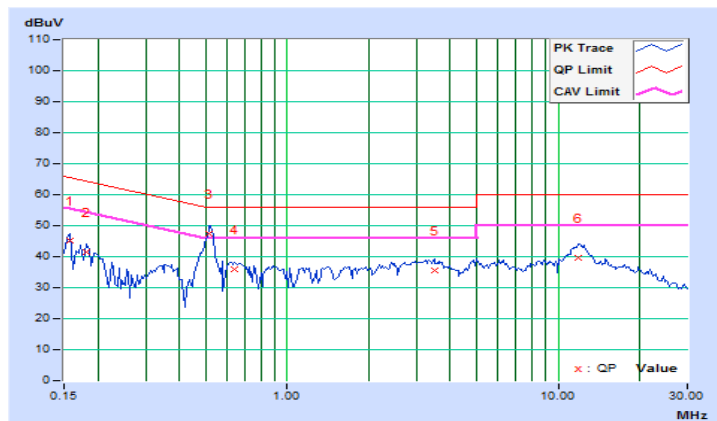

Phase	Neutral (N)	Detector Function	Quasi-Peak (QP) / Average (AV)
Test Mode	B		

No	Freq. [MHz]	Corr. Factor (dB)	Reading Value [dB (uV)]		Emission Level [dB (uV)]		Limit [dB (uV)]		Margin (dB)	
			Q.P.	AV.	Q.P.	AV.	Q.P.	AV.	Q.P.	AV.
			1	0.15391	10.01	35.85	21.69	45.86	31.70	65.79
2	0.16562	10.00	33.99	17.97	43.99	27.97	65.18	55.18	-21.19	-27.21
3	0.51981	10.04	37.56	32.91	47.60	42.95	56.00	46.00	-8.40	-3.05
4	0.67344	10.05	23.46	19.76	33.51	29.81	56.00	46.00	-22.49	-16.19
5	3.46094	10.22	22.71	17.33	32.93	27.55	56.00	46.00	-23.07	-18.45
6	12.36719	10.40	28.37	23.66	38.77	34.06	60.00	50.00	-21.23	-15.94

Remarks:

1. Q.P. and AV. are abbreviations of quasi-peak and average individually.
2. The emission levels of other frequencies were very low against the limit.
3. Margin value = Emission level - Limit value
4. Correction factor = Insertion loss + Cable loss
5. Emission Level = Correction Factor + Reading Value.

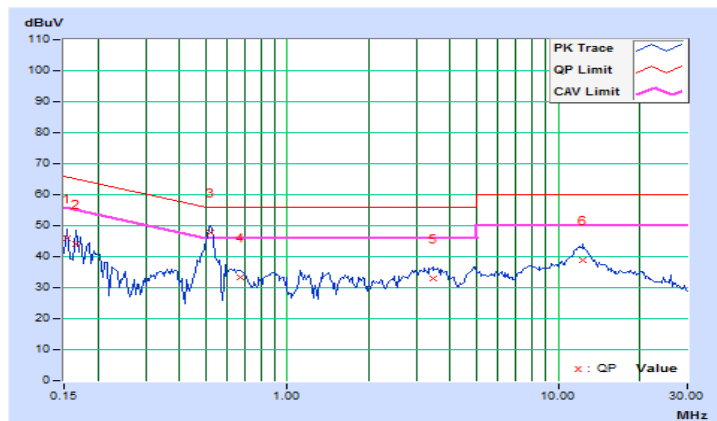

Phase	Line (L)	Detector Function	Quasi-Peak (QP) / Average (AV)
Test Mode	C		

No	Freq. [MHz]	Corr. Factor (dB)	Reading Value [dB (uV)]		Emission Level [dB (uV)]		Limit [dB (uV)]		Margin (dB)	
			Q.P.	AV.	Q.P.	AV.	Q.P.	AV.	Q.P.	AV.
			1	0.15781	10.01	35.69	17.68	45.70	27.69	65.58
2	0.19687	10.03	31.26	19.62	41.29	29.65	63.74	53.74	-22.45	-24.09
3	0.29844	10.03	26.78	17.70	36.81	27.73	60.29	50.29	-23.48	-22.56
4	0.35703	10.03	36.59	31.32	46.62	41.35	58.80	48.80	-12.18	-7.45
5	4.91797	10.16	14.46	6.78	24.62	16.94	56.00	46.00	-31.38	-29.06
6	8.81250	10.26	12.40	7.46	22.66	17.72	60.00	50.00	-37.34	-32.28

Remarks:

1. Q.P. and AV. are abbreviations of quasi-peak and average individually.
2. The emission levels of other frequencies were very low against the limit.
3. Margin value = Emission level - Limit value
4. Correction factor = Insertion loss + Cable loss
5. Emission Level = Correction Factor + Reading Value.

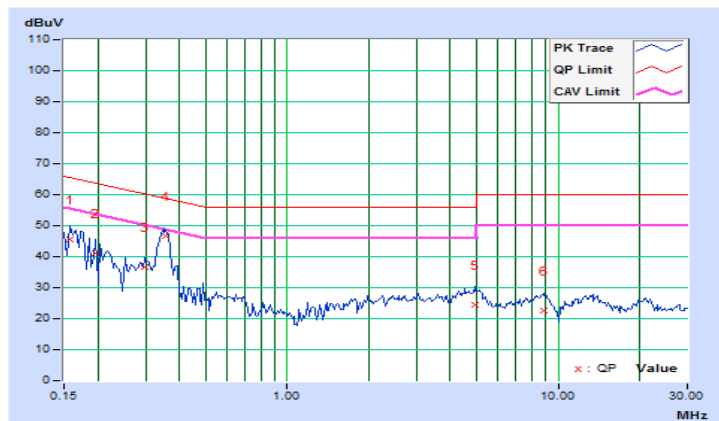

Phase	Neutral (N)	Detector Function	Quasi-Peak (QP) / Average (AV)
Test Mode	C		

No	Freq. [MHz]	Corr. Factor (dB)	Reading Value [dB (uV)]		Emission Level [dB (uV)]		Limit [dB (uV)]		Margin (dB)	
			Q.P.	AV.	Q.P.	AV.	Q.P.	AV.	Q.P.	AV.
			1	0.15000	10.02	37.73	23.30	47.75	33.32	66.00
2	0.16172	10.00	35.42	19.09	45.42	29.09	65.38	55.38	-19.96	-26.29
3	0.21641	9.98	30.07	21.27	40.05	31.25	62.96	52.96	-22.91	-21.71
4	0.34531	10.02	33.56	25.20	43.58	35.22	59.07	49.07	-15.49	-13.85
5	4.87891	10.26	14.55	6.83	24.81	17.09	56.00	46.00	-31.19	-28.91
6	12.97266	10.42	11.34	6.26	21.76	16.68	60.00	50.00	-38.24	-33.32

Remarks:

1. Q.P. and AV. are abbreviations of quasi-peak and average individually.
2. The emission levels of other frequencies were very low against the limit.
3. Margin value = Emission level - Limit value
4. Correction factor = Insertion loss + Cable loss
5. Emission Level = Correction Factor + Reading Value.

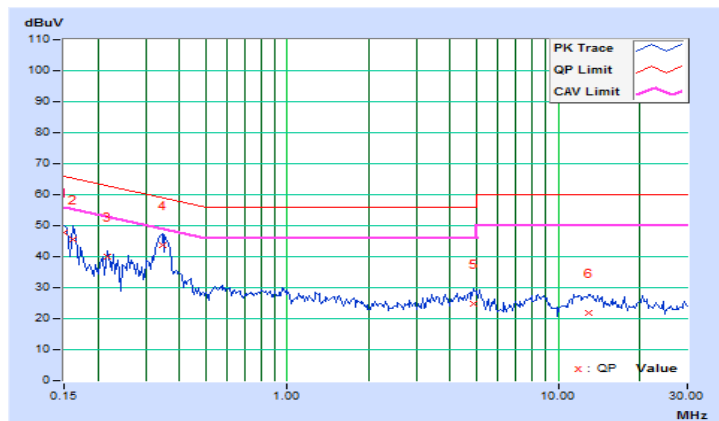

Phase	Line (L)	Detector Function	Quasi-Peak (QP) / Average (AV)
Test Mode	D		

No	Freq. [MHz]	Corr. Factor (dB)	Reading Value [dB (uV)]		Emission Level [dB (uV)]		Limit [dB (uV)]		Margin (dB)	
			Q.P.	AV.	Q.P.	AV.	Q.P.	AV.	Q.P.	AV.
			1	0.15781	10.01	37.90	24.04	47.91	34.05	65.58
2	0.20859	10.03	30.23	16.64	40.26	26.67	63.26	53.26	-23.00	-26.59
3	0.45469	10.04	18.96	8.55	29.00	18.59	56.79	46.79	-27.79	-28.20
4	0.53281	10.05	37.13	32.94	47.18	42.99	56.00	46.00	-8.82	-3.01
5	3.63672	10.13	24.90	20.39	35.03	30.52	56.00	46.00	-20.97	-15.48
6	10.42578	10.30	31.67	26.93	41.97	37.23	60.00	50.00	-18.03	-12.77

Remarks:

1. Q.P. and AV. are abbreviations of quasi-peak and average individually.
2. The emission levels of other frequencies were very low against the limit.
3. Margin value = Emission level - Limit value
4. Correction factor = Insertion loss + Cable loss
5. Emission Level = Correction Factor + Reading Value.

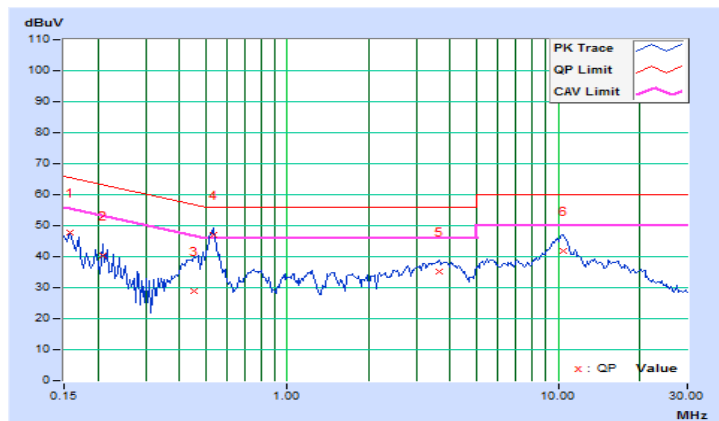

Phase	Neutral (N)	Detector Function	Quasi-Peak (QP) / Average (AV)
Test Mode	D		

No	Freq. [MHz]	Corr. Factor (dB)	Reading Value [dB (uV)]		Emission Level [dB (uV)]		Limit [dB (uV)]		Margin (dB)	
			Q.P.	AV.	Q.P.	AV.	Q.P.	AV.	Q.P.	AV.
			1	0.16172	10.00	36.62	20.07	46.62	30.07	65.38
2	0.52500	10.04	37.27	32.55	47.31	42.59	56.00	46.00	-8.69	-3.41
3	0.73984	10.05	19.61	15.53	29.66	25.58	56.00	46.00	-26.34	-20.42
4	3.73047	10.24	22.18	17.17	32.42	27.41	56.00	46.00	-23.58	-18.59
5	10.26563	10.32	30.86	26.21	41.18	36.53	60.00	50.00	-18.82	-13.47
6	19.92578	10.71	20.35	15.43	31.06	26.14	60.00	50.00	-28.94	-23.86

Remarks:

1. Q.P. and AV. are abbreviations of quasi-peak and average individually.
2. The emission levels of other frequencies were very low against the limit.
3. Margin value = Emission level - Limit value
4. Correction factor = Insertion loss + Cable loss
5. Emission Level = Correction Factor + Reading Value.

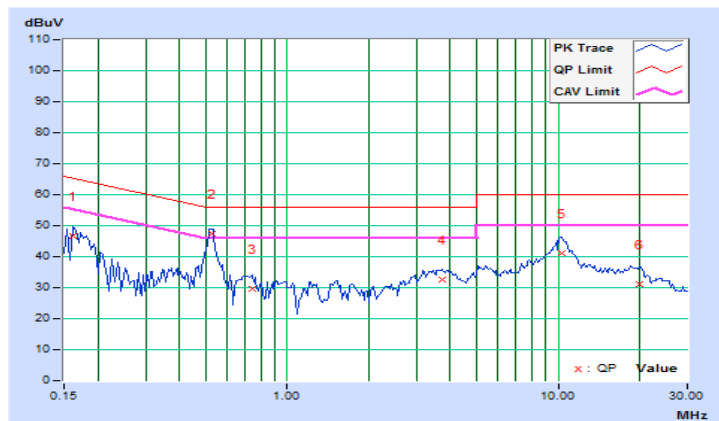

4.3 6dB Bandwidth Measurement

4.3.1 Limits of 6dB Bandwidth Measurement

The minimum of 6dB Bandwidth Measurement is 0.5 MHz.

4.3.2 Test Setup

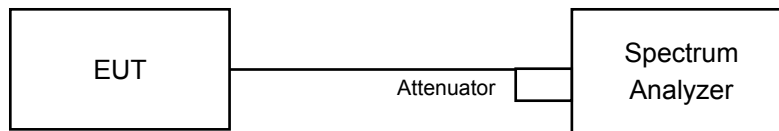

4.3.3 Test Instruments

Refer to section 4.1.2 to get information of above instrument.

4.3.4 Test Procedure

- Set resolution bandwidth (RBW) = 100kHz
- Set the video bandwidth (VBW) $\geq 3 \times$ RBW, Detector = average.
- Trace mode = max hold.
- Sweep = auto couple.
- Measure the maximum width of the emission that is constrained by the frequencies associated with the two amplitude points (upper and lower) that are attenuated by 6 dB relative to the maximum level measured in the fundamental emission

4.3.5 Deviation from Test Standard

No deviation.

4.3.6 EUT Operating Conditions

The software provided by client to enable the EUT under transmission condition continuously at lowest, middle and highest channel frequencies individually.

4.3.7 Test Result

802.11b

Channel	Frequency (MHz)	6dB Bandwidth (MHz)		Minimum Limit (MHz)	Pass / Fail
		Chain 0	Chain 1		
1	2412	8.12	7.64	0.5	Pass
6	2437	8.08	8.09	0.5	Pass
11	2462	8.09	8.13	0.5	Pass

802.11g

Channel	Frequency (MHz)	6dB Bandwidth (MHz)		Minimum Limit (MHz)	Pass / Fail
		Chain 0	Chain 1		
1	2412	16.40	16.42	0.5	Pass
6	2437	16.37	16.39	0.5	Pass
11	2462	16.41	16.42	0.5	Pass

802.11n (HT20)

Channel	Frequency (MHz)	6dB Bandwidth (MHz)		Minimum Limit (MHz)	Pass / Fail
		Chain 0	Chain 1		
1	2412	17.65	17.63	0.5	Pass
6	2437	17.65	17.62	0.5	Pass
11	2462	17.62	17.63	0.5	Pass

802.11n (HT40)

Channel	Frequency (MHz)	6dB Bandwidth (MHz)		Minimum Limit (MHz)	Pass / Fail
		Chain 0	Chain 1		
3	2422	35.21	35.30	0.5	Pass
6	2437	35.20	35.18	0.5	Pass
9	2452	35.33	35.22	0.5	Pass

Spectrum Plot of Worst Value

802.11b

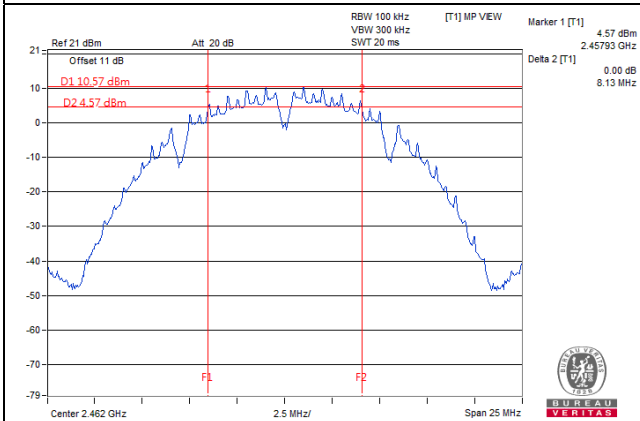

802.11g

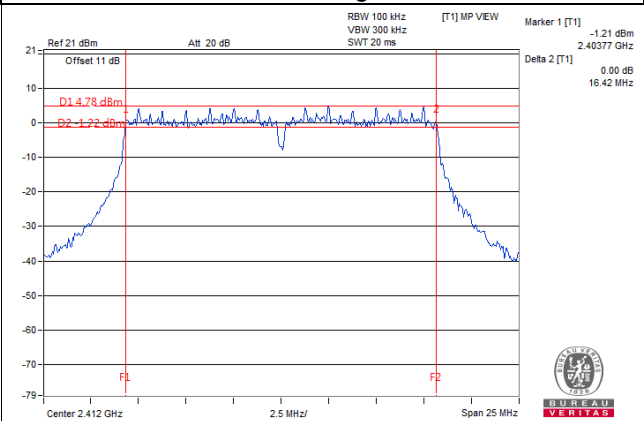

802.11n (HT20)

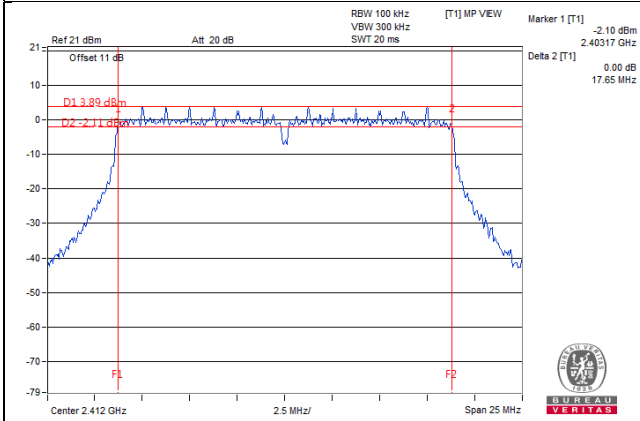

802.11n (HT40)

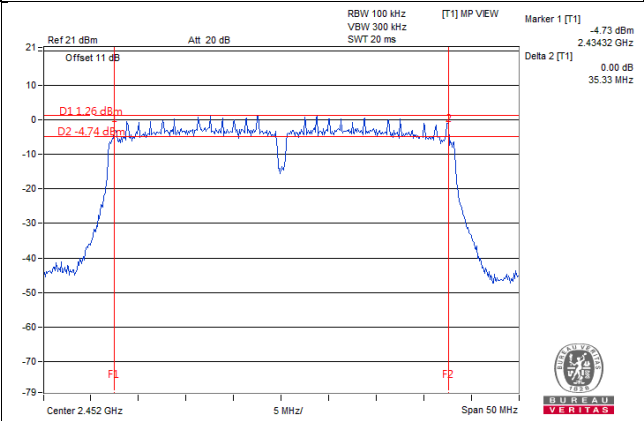

4.4 Conducted Output Power Measurement

4.4.1 Limits of Conducted Output Power Measurement

For systems using digital modulation in the 2400–2483.5 MHz bands: 1 Watt (30dBm)

Per KDB 662911 D01 Multiple Transmitter Output Method of conducted output power measurement on IEEE 802.11 devices,

Array Gain = 0 dB (i.e., no array gain) for $NANT \leq 4$;

Array Gain = 0 dB (i.e., no array gain) for channel widths ≥ 40 MHz for any NANT;

Array Gain = $5 \log(NANT/NSS)$ dB or 3 dB, whichever is less for 20-MHz channel widths with $NANT \geq 5$.

For power measurements on all other devices: Array Gain = $10 \log(NANT/NSS)$ dB.

4.4.2 Test Setup

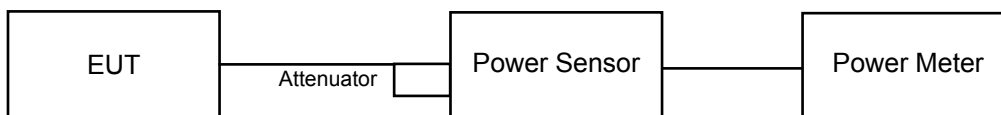

4.4.3 Test Instruments

Refer to section 4.1.2 to get information of above instrument.

4.4.4 Test Procedures

An average power sensor was used on the output port of the EUT. A power meter was used to read the response of the average power sensor. Record the power level.

4.4.5 Deviation from Test Standard

No deviation.

4.4.6 EUT Operating Conditions

Same as Item 4.3.6.

4.4.7 Test Results

CDD Mode

802.11b

Channel	Frequency (MHz)	Average Power (dBm)		Total Power (mW)	Total Power (dBm)	Limit (dBm)	Pass / Fail
		Chain 0	Chain 1				
1	2412	19.73	19.64	186.017	22.70	30.00	Pass
6	2437	18.59	18.27	139.420	21.44	30.00	Pass
11	2462	18.65	18.69	147.243	21.68	30.00	Pass

802.11g

Channel	Frequency (MHz)	Average Power (dBm)		Total Power (mW)	Total Power (dBm)	Limit (dBm)	Pass / Fail
		Chain 0	Chain 1				
1	2412	16.35	16.19	84.743	19.28	30.00	Pass
6	2437	21.82	21.79	303.063	24.82	30.00	Pass
11	2462	16.42	16.31	86.609	19.38	30.00	Pass

802.11n (HT20)

Channel	Frequency (MHz)	Average Power (dBm)		Total Power (mW)	Total Power (dBm)	Limit (dBm)	Pass / Fail
		Chain 0	Chain 1				
1	2412	16.63	16.74	93.232	19.70	30.00	Pass
6	2437	21.50	21.42	279.930	24.47	30.00	Pass
11	2462	16.65	16.62	92.158	19.65	30.00	Pass

802.11n (HT40)

Channel	Frequency (MHz)	Average Power (dBm)		Total Power (mW)	Total Power (dBm)	Limit (dBm)	Pass / Fail
		Chain 0	Chain 1				
3	2422	16.11	15.81	78.939	18.97	30.00	Pass
6	2437	16.98	16.95	99.433	19.98	30.00	Pass
9	2452	16.03	16.08	80.638	19.07	30.00	Pass

Beamforming Mode

802.11n (HT20)

Channel	Frequency (MHz)	Average Power (dBm)		Total Power (mW)	Total Power (dBm)	Limit (dBm)	Pass / Fail
		Chain 0	Chain 1				
1	2412	13.62	13.73	46.619	16.69	28.41	Pass
6	2437	18.49	18.41	139.975	21.46	28.41	Pass
11	2462	13.64	13.61	46.082	16.64	28.41	Pass

Note: Directional gain = $4.58\text{dBi} + 10\log(2) = 7.59\text{dBi} > 6\text{dBi}$, so the power limit shall be reduced to $30 - (7.59 - 6) = 28.41\text{dBm}$.

802.11n (HT40)

Channel	Frequency (MHz)	Average Power (dBm)		Total Power (mW)	Total Power (dBm)	Limit (dBm)	Pass / Fail
		Chain 0	Chain 1				
3	2422	13.10	12.80	39.472	15.96	28.41	Pass
6	2437	13.97	13.94	49.720	16.97	28.41	Pass
9	2452	13.02	13.07	40.322	16.06	28.41	Pass

Note: Directional gain = $4.58\text{dBi} + 10\log(2) = 7.59\text{dBi} > 6\text{dBi}$, so the power limit shall be reduced to $30 - (7.59 - 6) = 28.41\text{dBm}$.

4.5 Power Spectral Density Measurement

4.5.1 Limits of Power Spectral Density Measurement

The Maximum of Power Spectral Density Measurement is 8dBm.

4.5.2 Test Setup

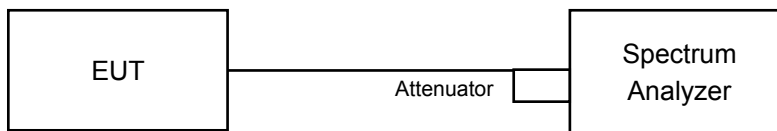

4.5.3 Test Instruments

Refer to section 4.1.2 to get information of above instrument.

4.5.4 Test Procedure

Duty cycle $\geq 98\%$

- Set instrument center frequency to DTS channel center frequency.
- Set span to at least 1.5 times the OBW.
- Set RBW to: $3 \text{ kHz} \leq \text{RBW} \leq 100 \text{ kHz}$.
- Set VBW $\geq 3 \times \text{RBW}$.
- Detector = power averaging (RMS) or sample detector (when RMS not available).
- Ensure that the number of measurement points in the sweep $\geq 2 \times \text{span}/\text{RBW}$.
- Sweep time = auto couple.
- Employ trace averaging (RMS) mode over a minimum of 100 traces.
- Use the peak marker function to determine the maximum amplitude level.

Duty cycle $< 98\%$

- Measure the duty cycle (x).
- Set instrument center frequency to DTS channel center frequency.
- Set span to at least 1.5 times the OBW.
- Set RBW to: $3 \text{ kHz} \leq \text{RBW} \leq 100 \text{ kHz}$.
- Set VBW $\geq 3 \times \text{RBW}$.
- Detector = power averaging (RMS) or sample detector (when RMS not available).
- Ensure that the number of measurement points in the sweep $\geq 2 \times \text{span}/\text{RBW}$.
- Sweep time = auto couple.
- Do not use sweep triggering. Allow sweep to “free run”.
- Employ trace averaging (RMS) mode over a minimum of 100 traces.
- Use the peak marker function to determine the maximum amplitude level.
- Add $10 \log (1/x)$, where x is the duty cycle measured in step (a), to the measured PSD to compute the average PSD during the actual transmission time.

4.5.5 Deviation from Test Standard

No deviation.

4.5.6 EUT Operating Condition

Same as Item 4.3.6

4.5.7 Test Results

802.11b

TX chain	Channel	Frequency (MHz)	PSD (dBm/10kHz)	10 log (N=2) dB	Total PSD (dBm/10kHz)	Limit (dBm/3kHz)	Pass / Fail
0	1	2412	-8.48	3.01	-5.47	6.41	Pass
	6	2437	-9.78	3.01	-6.77	6.41	Pass
	11	2462	-9.96	3.01	-6.95	6.41	Pass
1	1	2412	-7.86	3.01	-4.85	6.41	Pass
	6	2437	-9.36	3.01	-6.35	6.41	Pass
	11	2462	-8.65	3.01	-5.64	6.41	Pass

Note:

- Method 1 of power density measurement of KDB 662911 is using for calculating total power density. Total power density is summing entire spectra across corresponding frequency bins on the various outputs by computer.
- Directional gain = $4.58\text{dBi} + 10\log(2) = 7.59\text{dBi} > 6\text{dBi}$, so the power density limit shall be reduced to $8 - (7.59 - 6) = 6.41\text{dBm}$

802.11g

TX chain	Channel	Freq. (MHz)	PSD w/o Duty Factor (dBm/10kHz)	10 log (N=2) dB	Duty Factor (dB)	Total PSD With Duty Factor (dBm/10kHz)	Limit (dBm/3kHz)	Pass / Fail
0	1	2412	-15.73	3.01	0.21	-12.51	6.41	Pass
	6	2437	-10.22	3.01	0.21	-7.00	6.41	Pass
	11	2462	-15.59	3.01	0.21	-12.37	6.41	Pass
1	1	2412	-14.81	3.01	0.21	-11.59	6.41	Pass
	6	2437	-9.13	3.01	0.21	-5.91	6.41	Pass
	11	2462	-14.82	3.01	0.21	-11.60	6.41	Pass

Note:

- Method 1 of power density measurement of KDB 662911 is using for calculating total power density. Total power density is summing entire spectra across corresponding frequency bins on the various outputs by computer.
- Directional gain = $4.58\text{dBi} + 10\log(2) = 7.59\text{dBi} > 6\text{dBi}$, so the power density limit shall be reduced to $8 - (7.59 - 6) = 6.41\text{dBm}$
- Refer to section 3.3 for duty cycle spectrum plot.

802.11n (HT20)

TX chain	Channel	Frequency (MHz)	PSD (dBm/10kHz)	10 log (N=2) dB	Total PSD (dBm/10kHz)	Limit (dBm/3kHz)	Pass / Fail
0	1	2412	-15.75	3.01	-12.74	6.41	Pass
	6	2437	-10.59	3.01	-7.58	6.41	Pass
	11	2462	-15.66	3.01	-12.65	6.41	Pass
1	1	2412	-14.34	3.01	-11.33	6.41	Pass
	6	2437	-9.69	3.01	-6.68	6.41	Pass
	11	2462	-14.08	3.01	-11.07	6.41	Pass

Note:

- Method 1 of power density measurement of KDB 662911 is using for calculating total power density. Total power density is summing entire spectra across corresponding frequency bins on the various outputs by computer.
- Directional gain = $4.58\text{dBi} + 10\log(2) = 7.59\text{dBi} > 6\text{dBi}$, so the power density limit shall be reduced to $8 - (7.59 - 6) = 6.41\text{dBm}$

802.11n (HT40)

TX chain	Channel	Freq. (MHz)	PSD w/o Duty Factor (dBm/10kHz)	10 log (N=2) dB	Duty Factor (dB)	Total PSD With Duty Factor (dBm/10kHz)	Limit (dBm/3kHz)	Pass / Fail
0	3	2422	-19.75	3.01	0.16	-16.58	6.41	Pass
	6	2437	-18.34	3.01	0.16	-15.17	6.41	Pass
	9	2452	-19.43	3.01	0.16	-16.26	6.41	Pass
1	3	2422	-18.32	3.01	0.16	-15.15	6.41	Pass
	6	2437	-17.69	3.01	0.16	-14.52	6.41	Pass
	9	2452	-18.01	3.01	0.16	-14.84	6.41	Pass

Note:

- Method 1 of power density measurement of KDB 662911 is using for calculating total power density. Total power density is summing entire spectra across corresponding frequency bins on the various outputs by computer.
- Directional gain = $4.58\text{dBi} + 10\log(2) = 7.59\text{dBi} > 6\text{dBi}$, so the power density limit shall be reduced to $8 - (7.59 - 6) = 6.41\text{dBm}$
- Refer to section 3.3 for duty cycle spectrum plot.

Spectrum Plot of Worst Value

802.11b

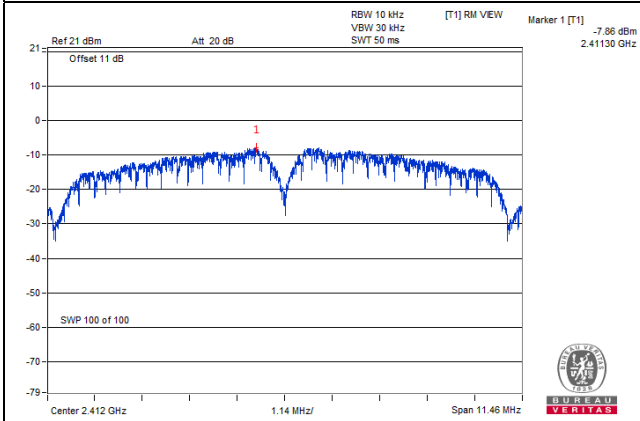

802.11g

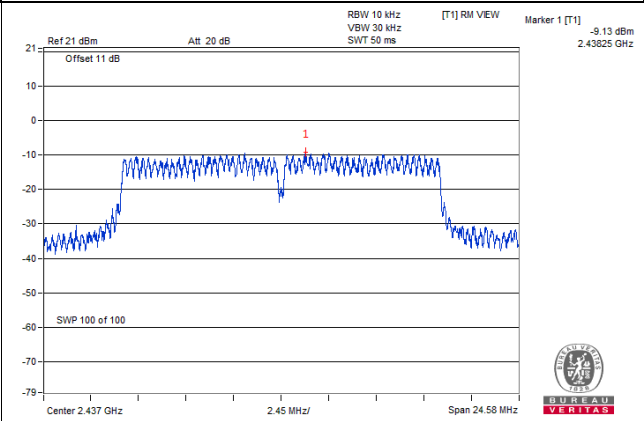

802.11n (HT20)

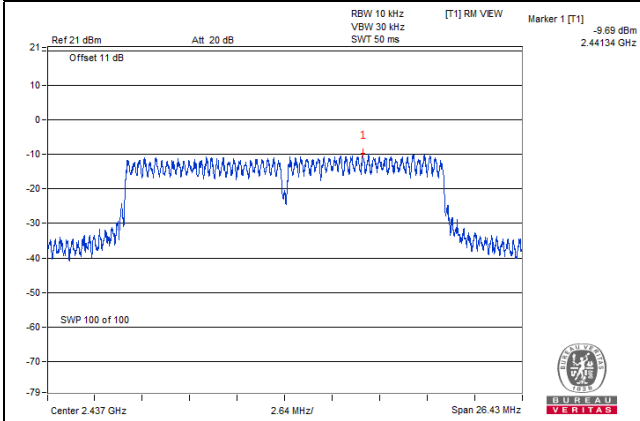

802.11n (HT40)

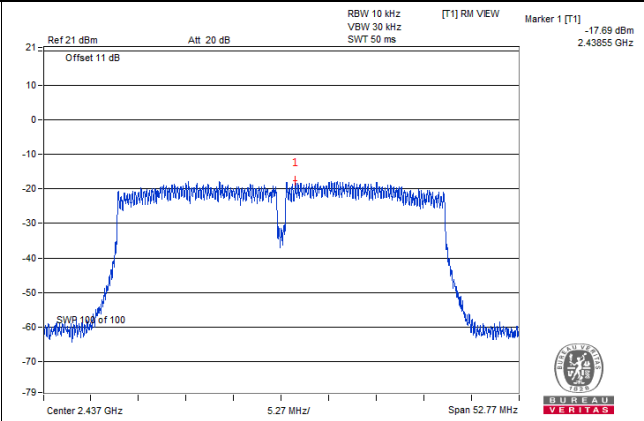

4.6 Conducted Out of Band Emission Measurement

4.6.1 Limits of Conducted Out of Band Emission Measurement

Below 30dB of the highest emission level of operating band (in 100kHz Resolution Bandwidth).

4.6.2 Test Setup

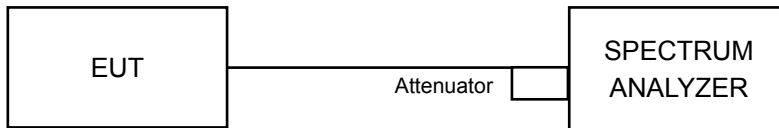

4.6.3 Test Instruments

Refer to section 4.1.2 to get information of above instrument.

4.6.4 Test Procedure

MEASUREMENT PROCEDURE REF

- Set the RBW = 100 kHz.
- Set the VBW \geq 300 kHz.
- Detector = average.
- Sweep time = auto couple.
- Trace mode = max hold.
- Allow trace to fully stabilize.
- Use the peak marker function to determine the maximum power level in any 100 kHz band segment within the fundamental EBW.

MEASUREMENT PROCEDURE OOB

- Set RBW = 100 kHz.
- Set VBW \geq 300 kHz.
- Ensure that the number of measurement points \geq span/RBW
- According to measurement points to set differ measurement span.
- Detector = average.
- Trace Mode = max hold.
- Sweep = auto couple.

4.6.5 Deviation from Test Standard

No deviation.

4.6.6 EUT Operating Condition

Same as Item 4.3.6

4.6.7 Test Results

The spectrum plots are attached on the following pages. D1 line indicates the highest level, and D2 line indicates the 30dB offset below D1. It shows compliance with the requirement.

802.11b_Chain 0

CH 1

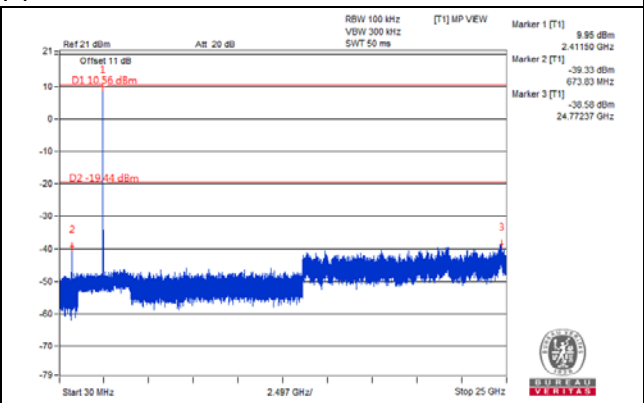
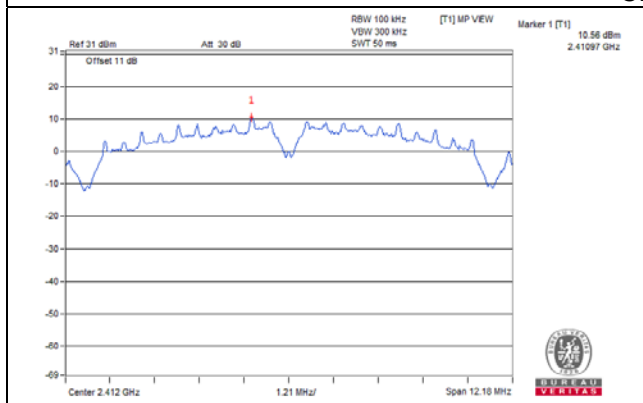

CH 6

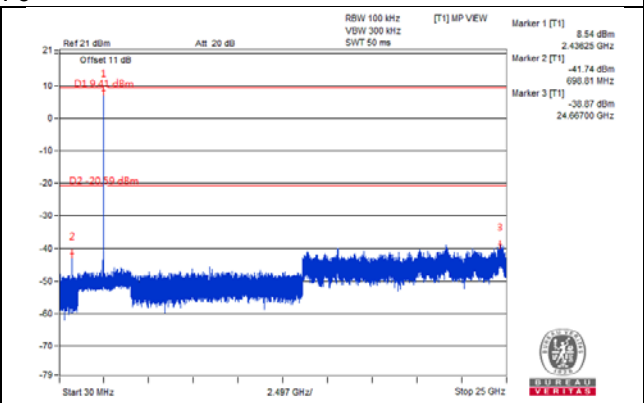
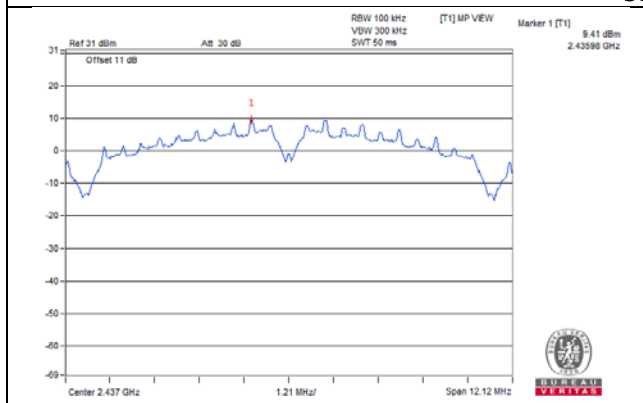

CH 11

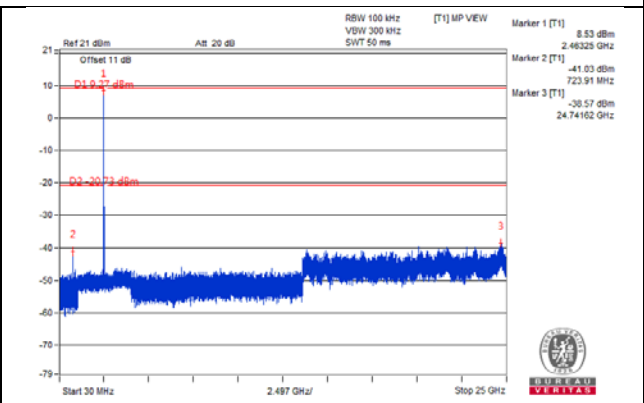
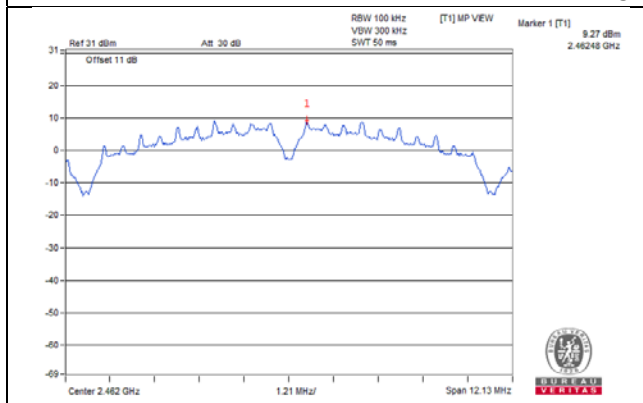

CH 1 Band edge

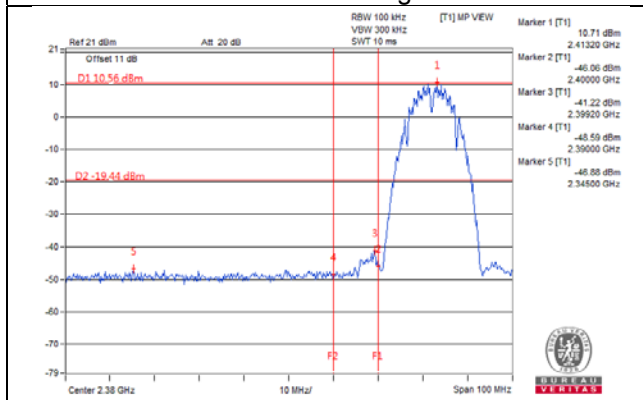

CH 11 Band edge

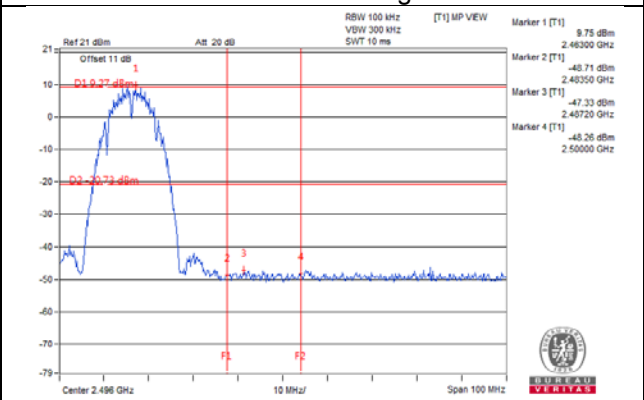

802.11b_Chain 1

CH 1

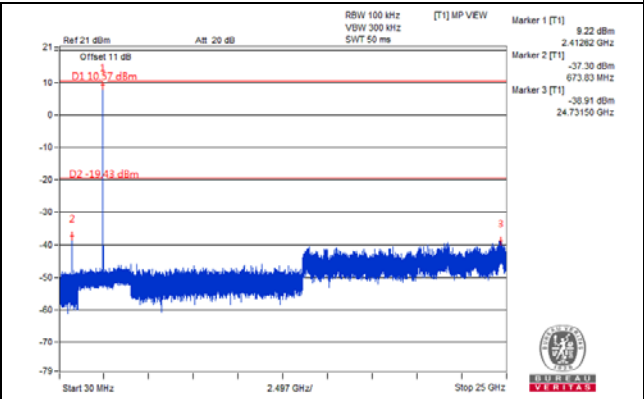
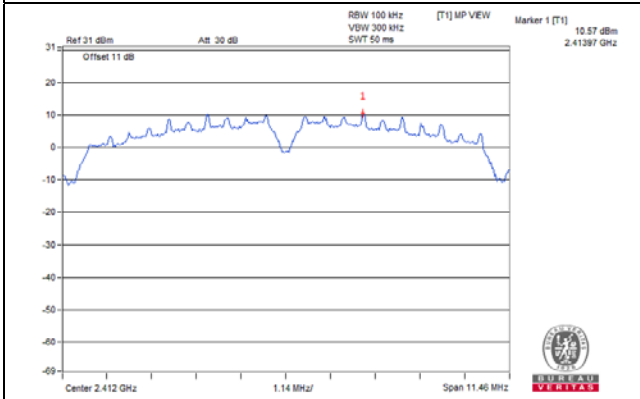

CH 6

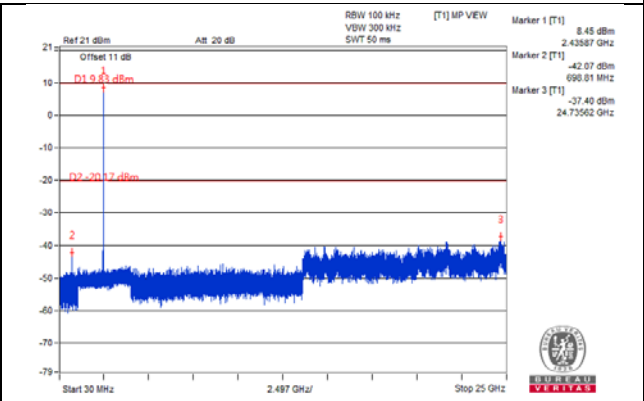
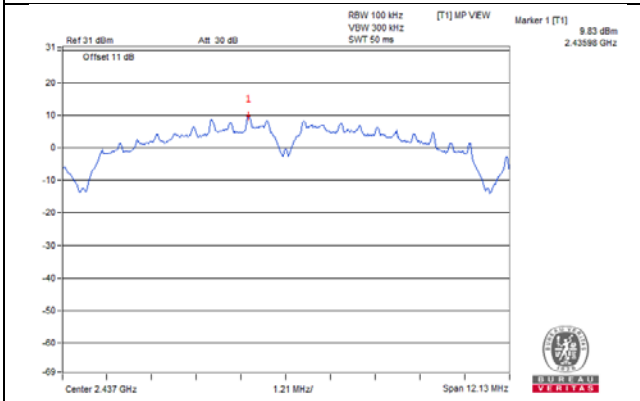

CH 11

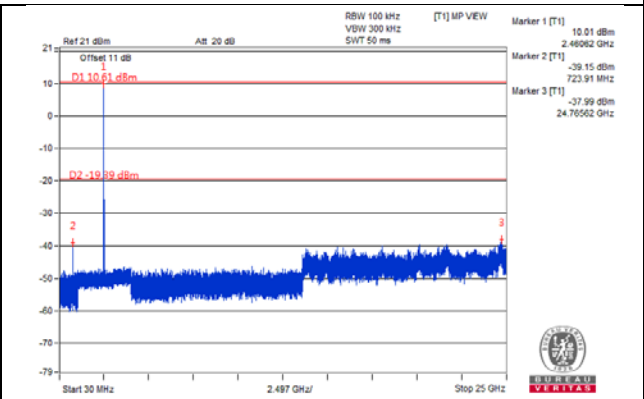
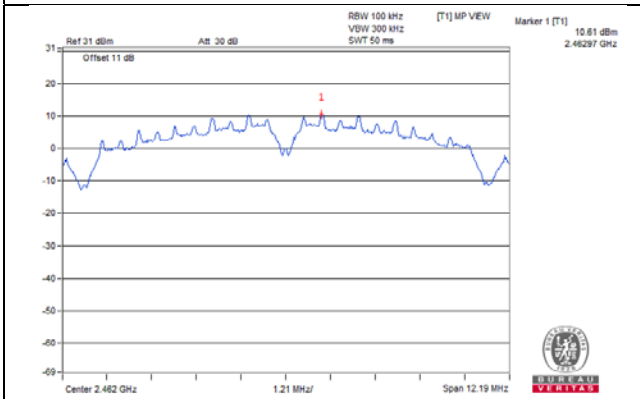

CH 1 Band edge

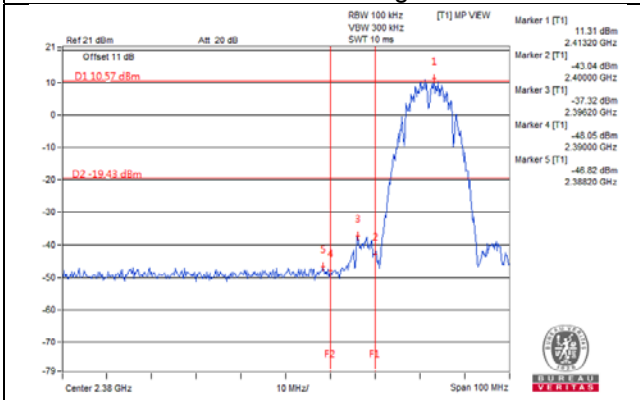

CH 11 Band edge

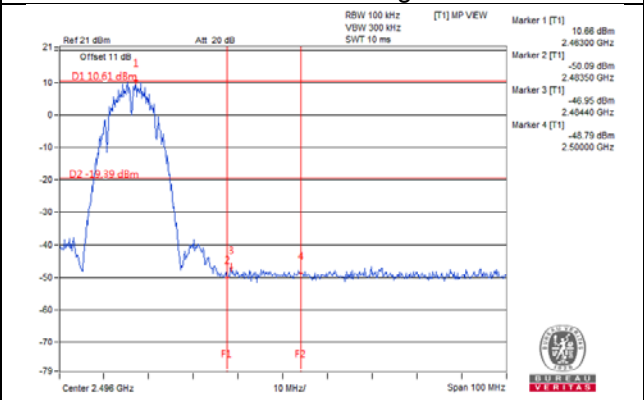

802.11g_Chain 0

CH 1

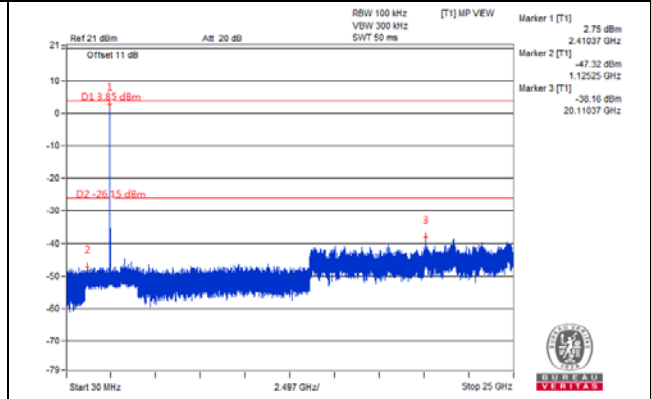
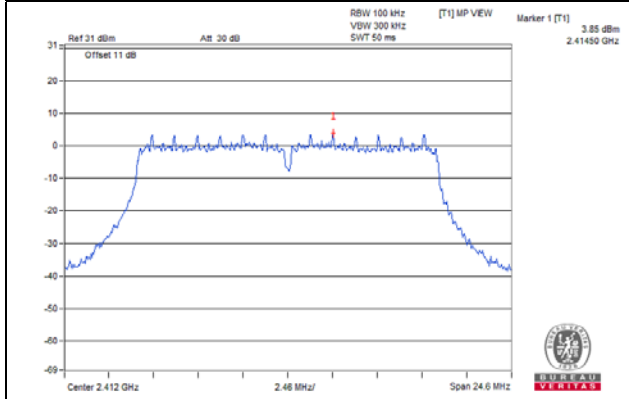

CH 6

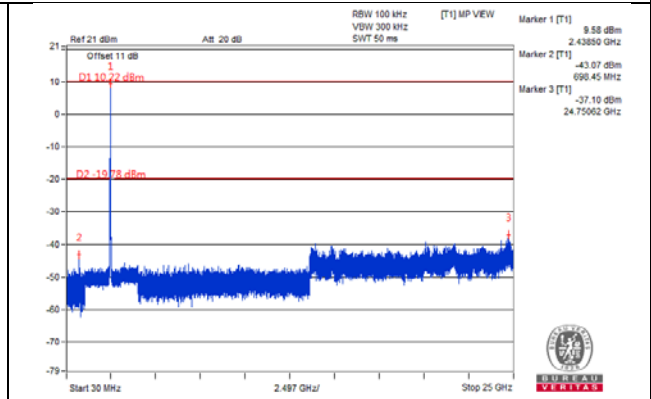
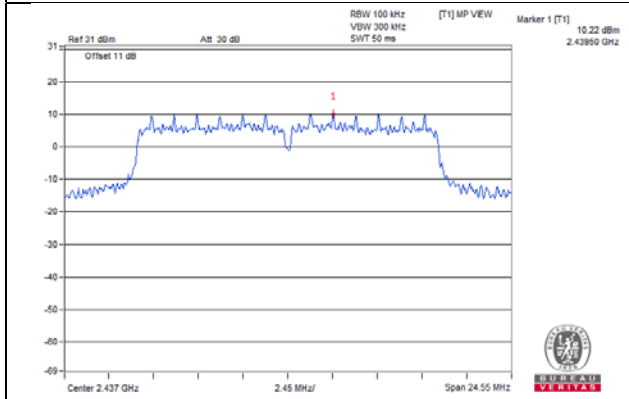

CH 11

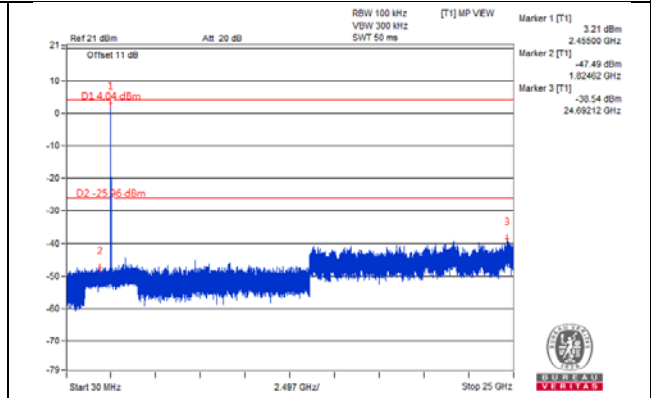
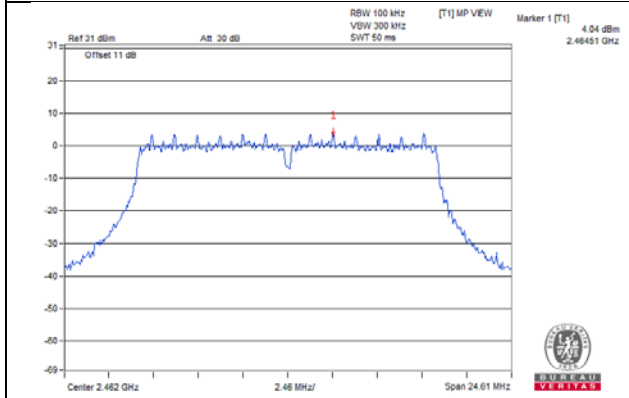

CH 1 Band edge

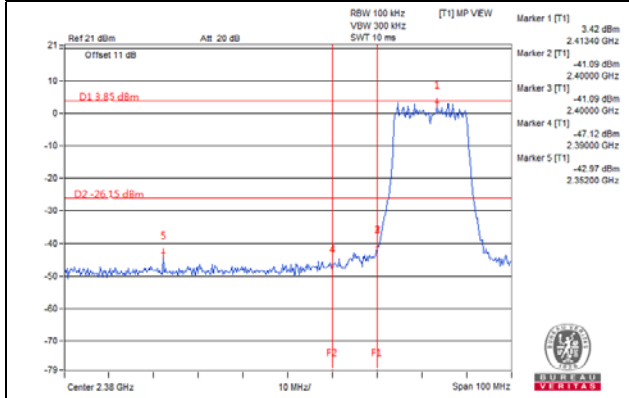

CH 11 Band edge

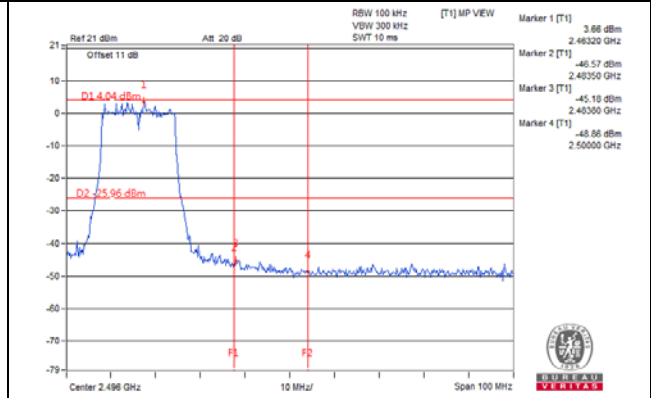

802.11g_Chain 1

CH 1

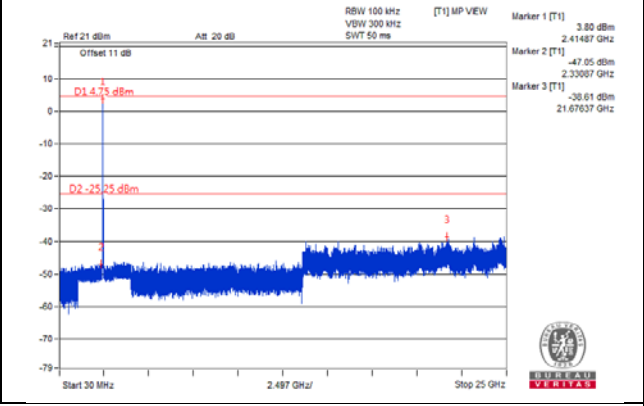
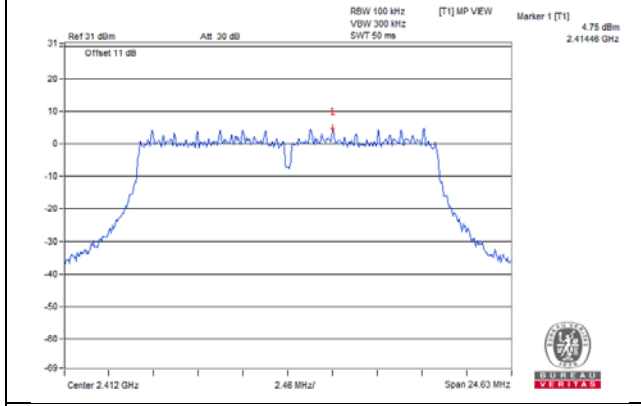

CH 6

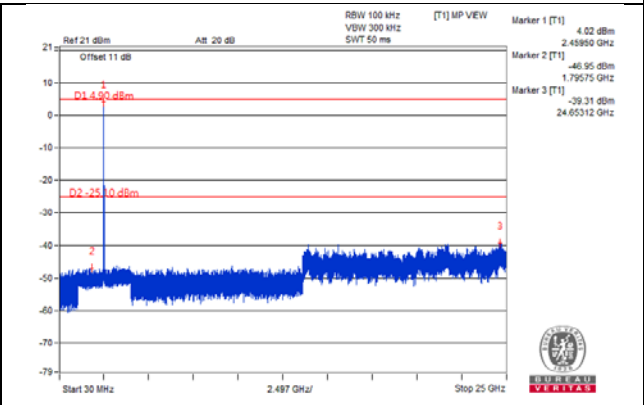
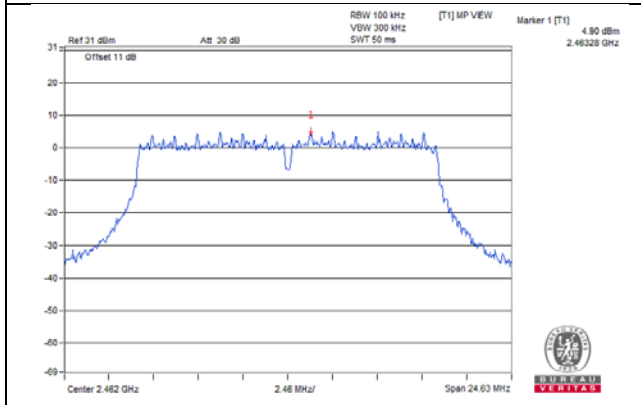
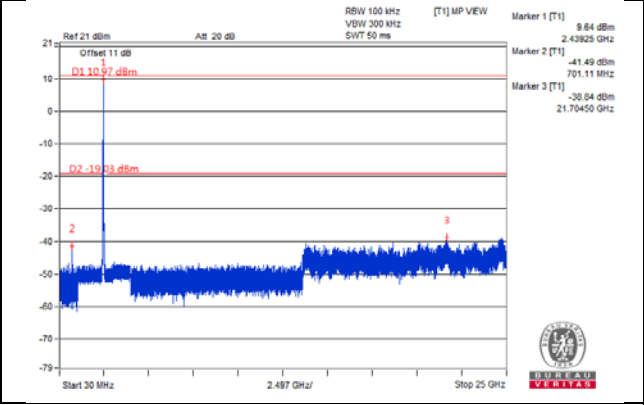
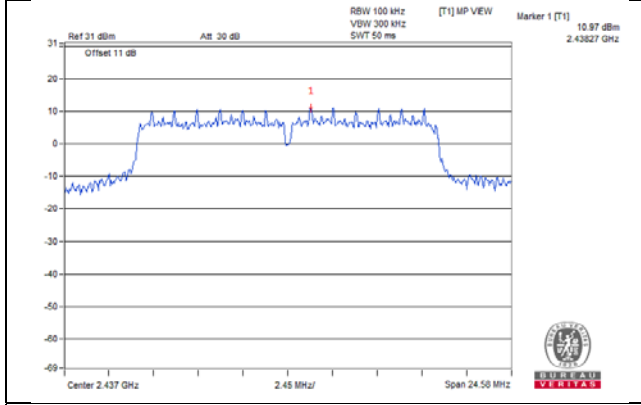

CH 1 Band edge

CH 11 Band edge

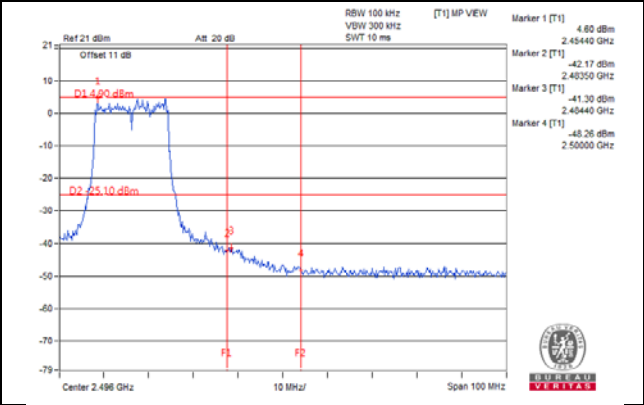
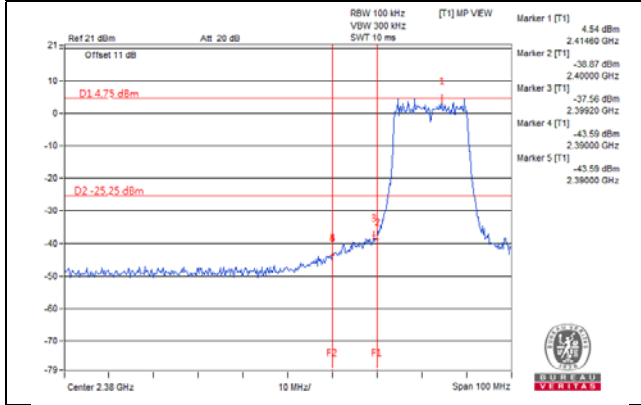

802.11n (HT20)_Chain 0

CH 1

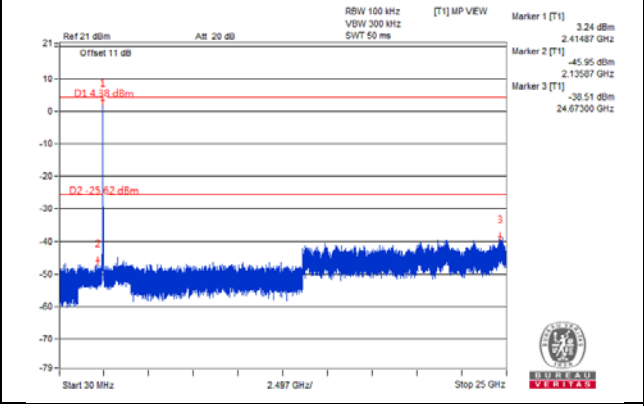
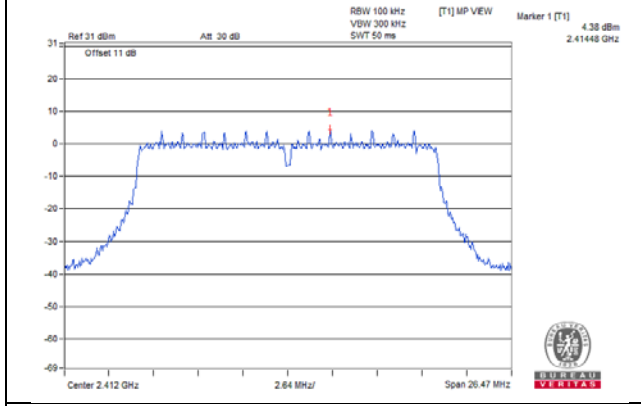

CH 6

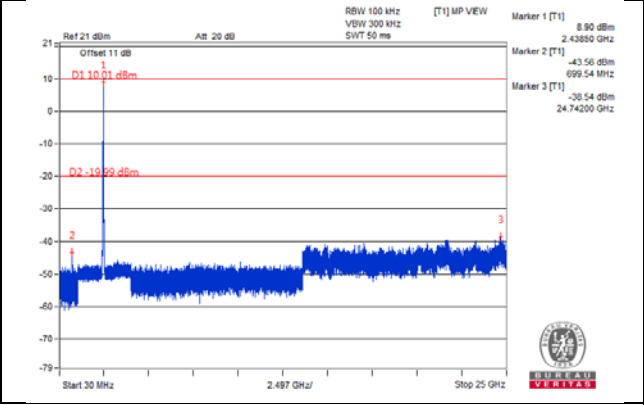
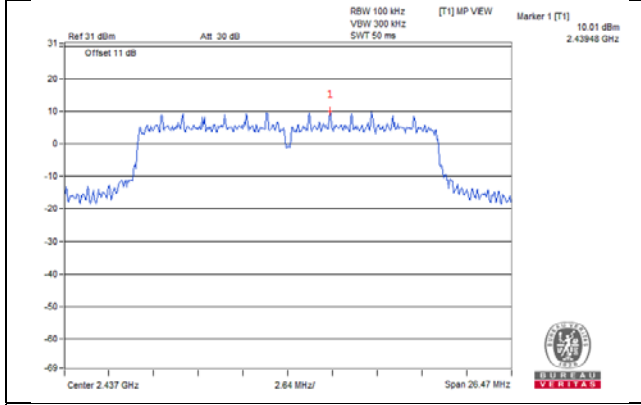

CH 11

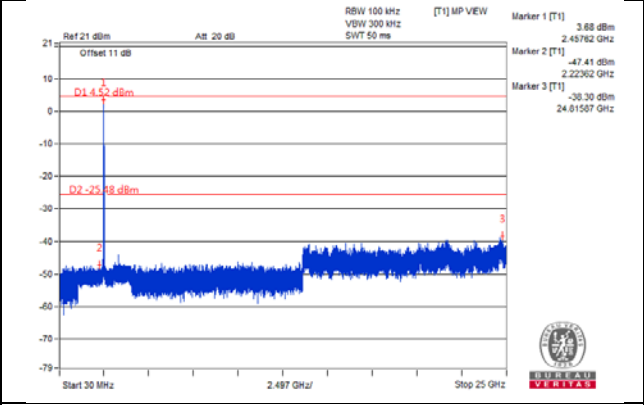
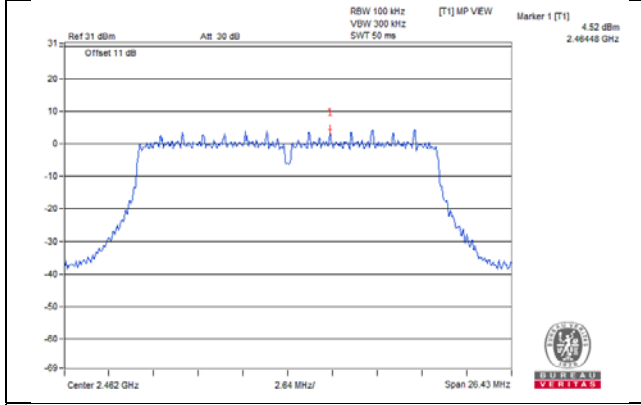

CH 1 Band edge

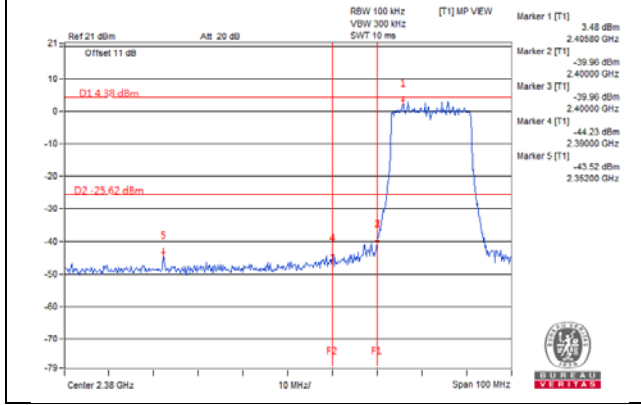

CH 11 Band edge

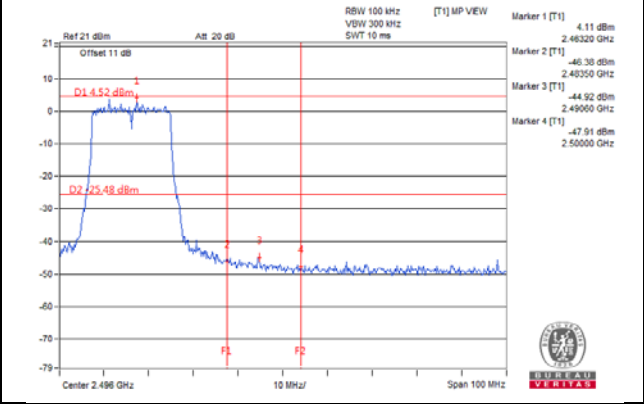

802.11n (HT20)_Chain 1

CH 1

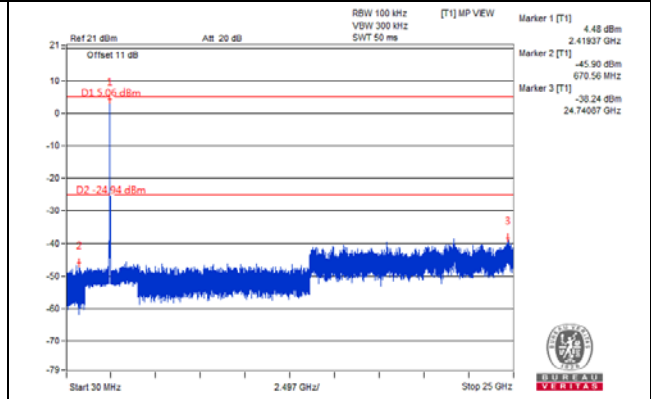
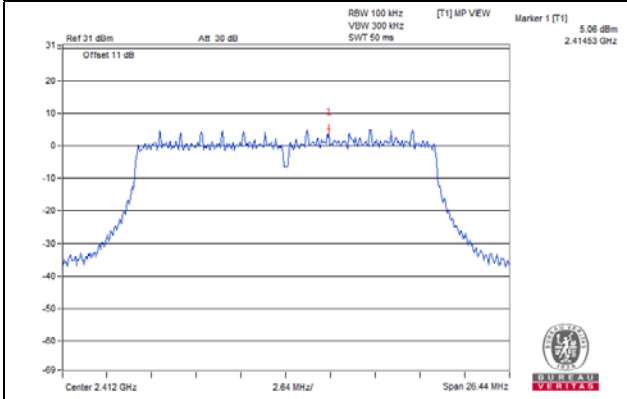

CH 6

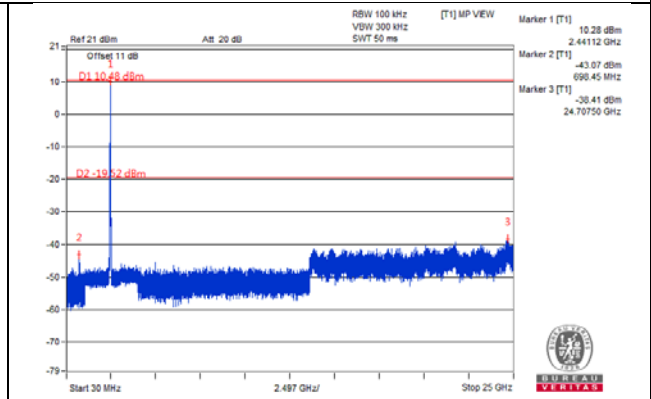
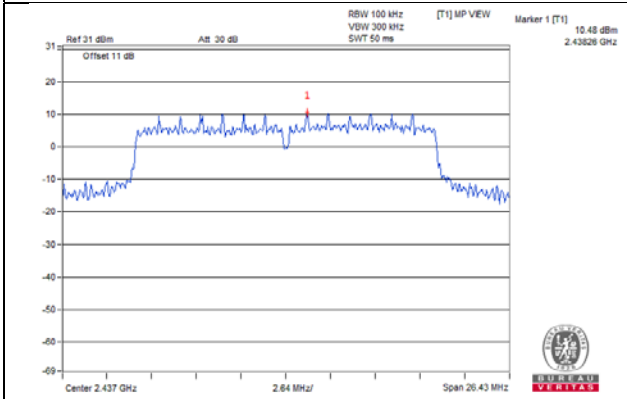

CH 11

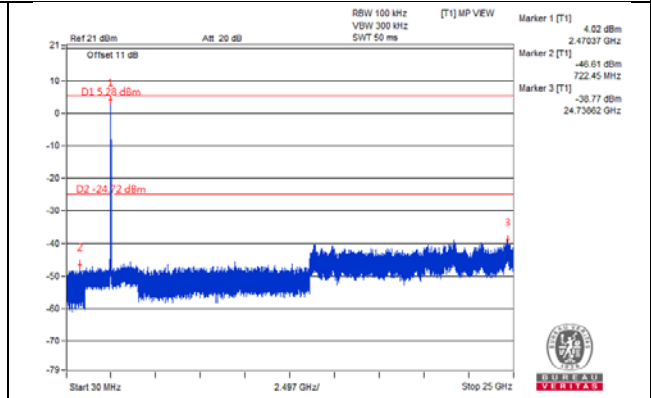
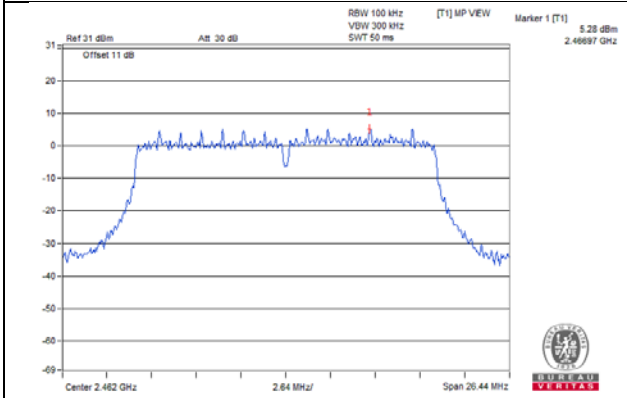

CH 1 Band edge

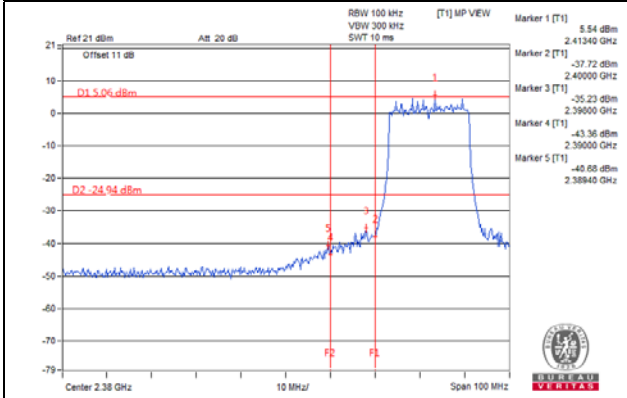

CH 11 Band edge

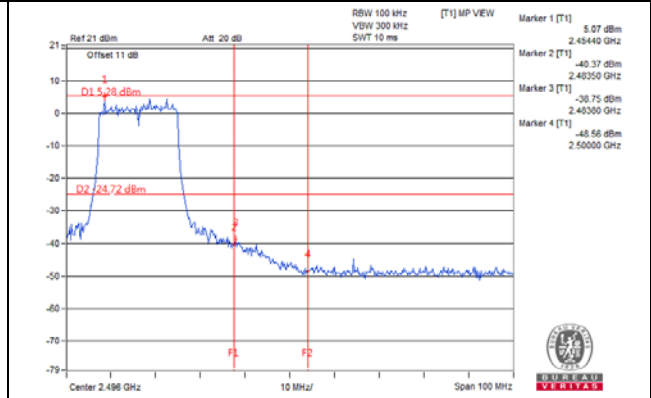

802.11n (HT40)_Chain 0

CH 3

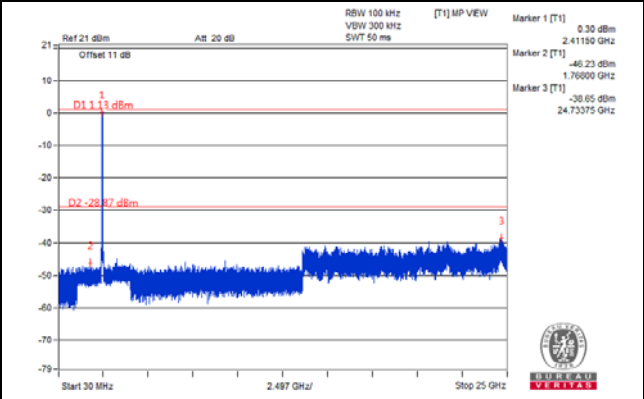
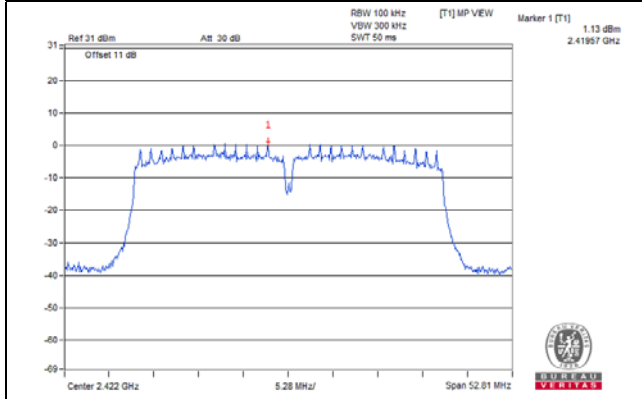

CH 6

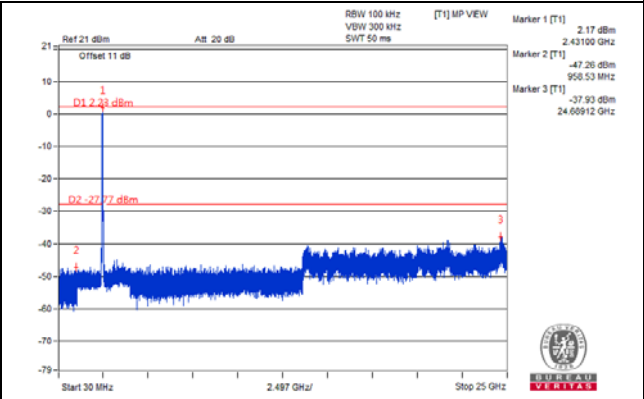
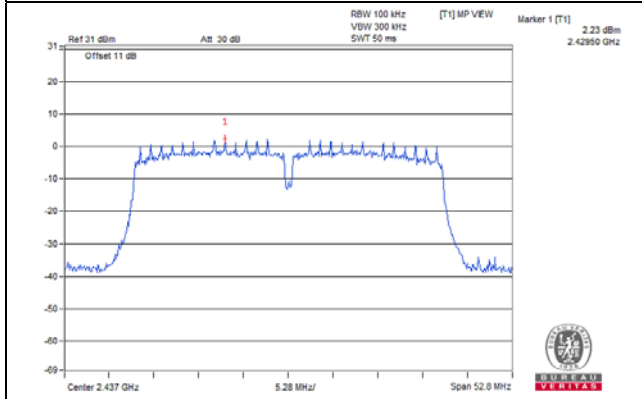

CH 9

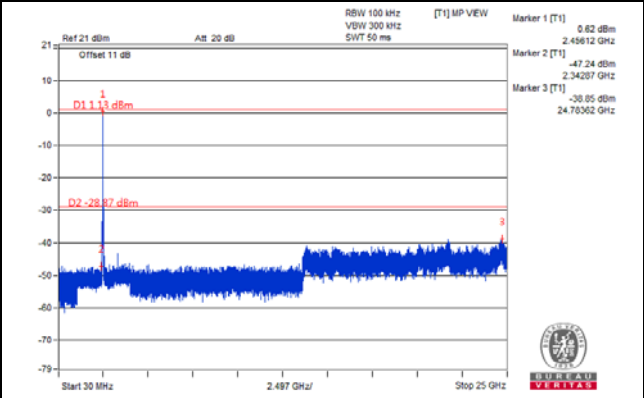
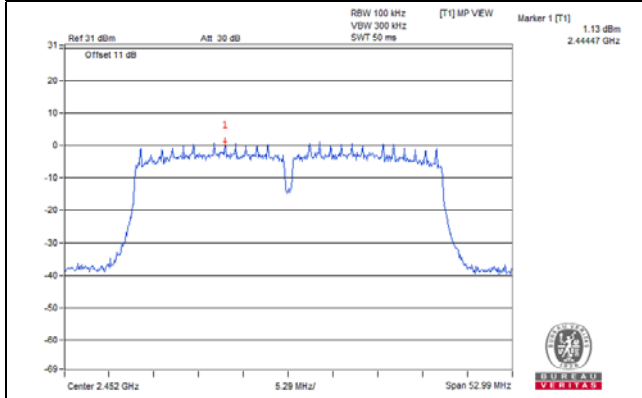

CH 3 Band edge

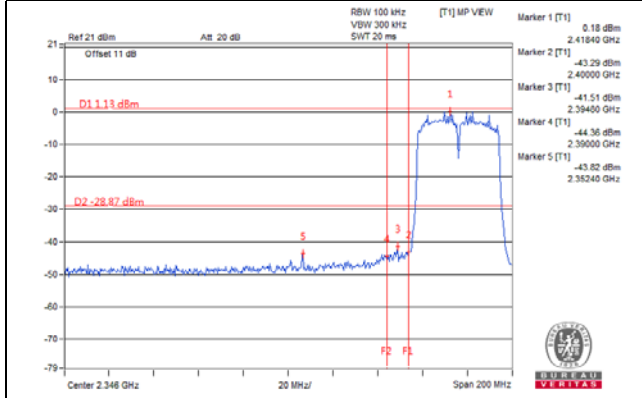

CH 9 Band edge

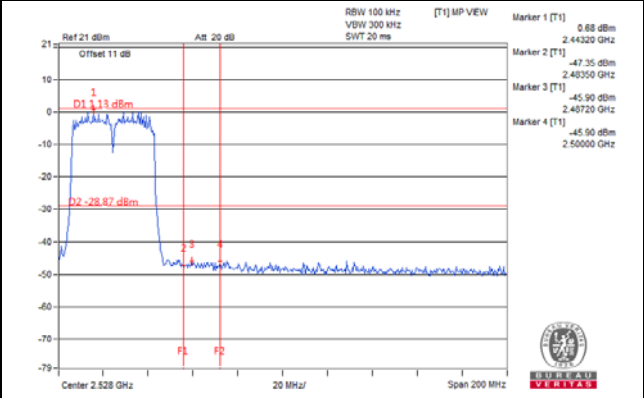

802.11n (HT40)_Chain 1

CH 3

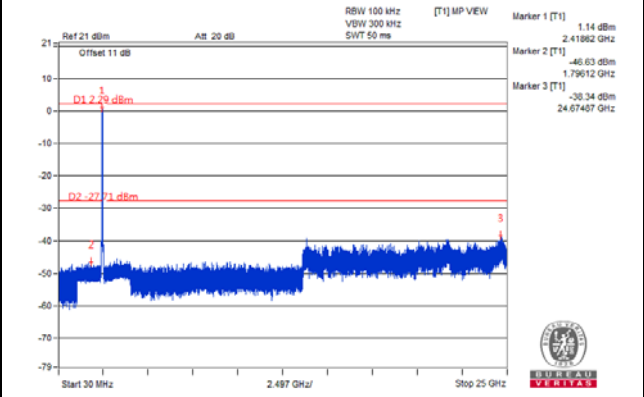
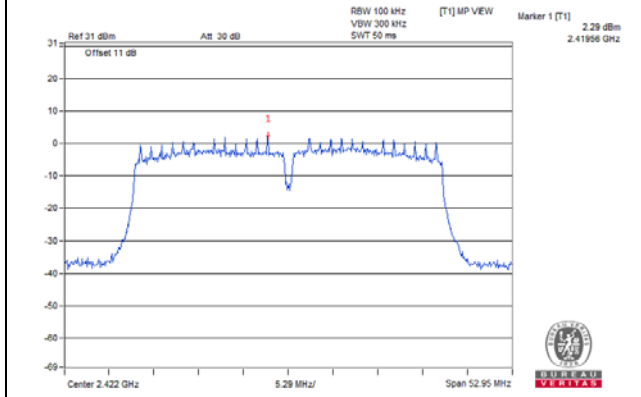

CH 6

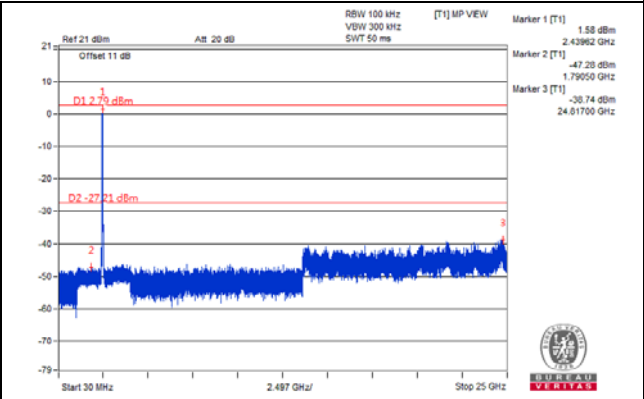
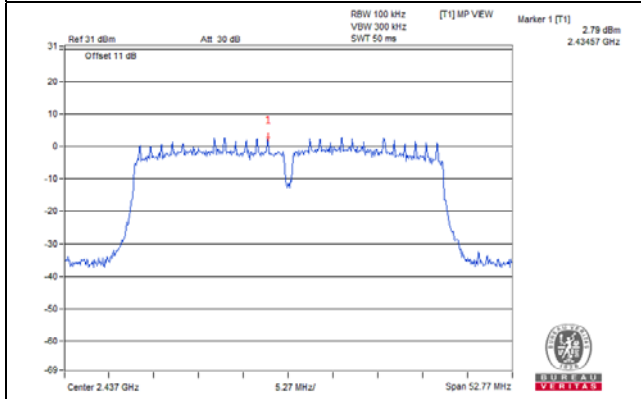

CH 9

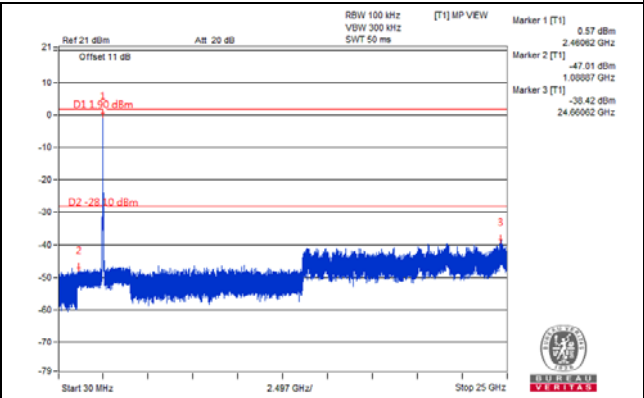
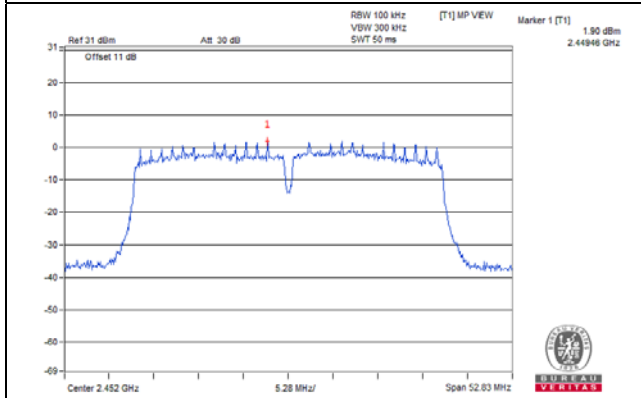

CH 3 Band edge

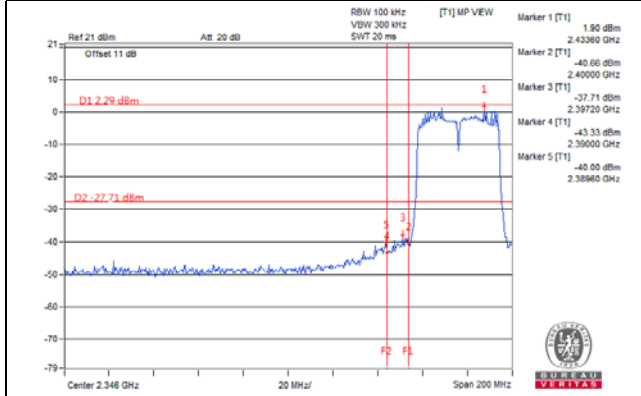

CH 9 Band edge

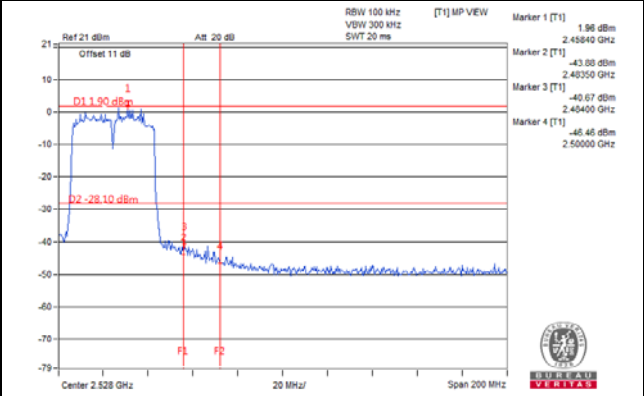

5 Pictures of Test Arrangements

Please refer to the attached file (Test Setup Photo).

Appendix – Information on the Testing Laboratories

We, Bureau Veritas Consumer Products Services (H.K.) Ltd., Taoyuan Branch, were founded in 1988 to provide our best service in EMC, Radio, Telecom and Safety consultation. Our laboratories are accredited and approved according to ISO/IEC 17025.

If you have any comments, please feel free to contact us at the following:

Linko EMC/RF Lab

Tel: 886-2-26052180

Fax: 886-2-26051924

Hsin Chu EMC/RF/Telecom Lab

Tel: 886-3-6668565

Fax: 886-3-6668323

Hwa Ya EMC/RF/Safety Lab

Tel: 886-3-3183232

Fax: 886-3-3270892

Email: service.adt@tw.bureauveritas.com

Web Site: www.bureauveritas-adt.com

The address and road map of all our labs can be found in our web site also.

--- END ---