

TEST REPORT

of

FCC PART 15 SUBPART E

New Application; Class I PC; Class II PC

Product : FortiWiFi 61F, FortiWiFi 60F

Brand: FORTINET

Model: FortiWiFi 60Fxxxxxx; FWF-60Fxxxxxx;
FORTIWIFI-60Fxxxxxx;
FortiWiFi 61Fxxxxxx; FWF-61Fxxxxxx;
FORTIWIFI-61Fxxxxxx;
(where “x” can be used “A-Z”, or “0-9”, or “-“, or blank for software purposes or marketing purposes only)

Model Difference: 61 series had SSD

FCC ID: TVE-121757A

FCC Rule Part: §15.407, Cat:NII

Applicant: Fortinet Inc.

Address: 899 KIFER RD SUNNYVALE CA 94086-5301
UNITED STATES

Test Performed by:
International Standards Laboratory Corp.

<LT Lab.>

*Site Registration No.

BSMI: SL2-IN-E-0013; MRA TW0997; TAF: 0997; IC: IC4067B-4;

*Address:

No. 120, Lane 180, Hsin Ho Rd., Lung-Tan Dist., Tao Yuan City 325, Taiwan

*Tel : 886-3-407-1718; Fax: 886-3-407-1738

Report No.: **ISL-19LR269FE-A**

Issue Date : **2020/01/17**



Test results given in this report apply only to the specific sample(s) tested and are traceable to national or international standard through calibration of the equipment and evaluating measurement uncertainty herein.

This report MUST not be used to claim product endorsement by TAF or any agency of the Government.

This test report shall not be reproduced except in full, without the written approval of International Standards Laboratory Corp.

VERIFICATION OF COMPLIANCE

Applicant: Fortinet Inc.

Product Description: FortiWiFi 61F, FortiWiFi 60F

Brand Name: FORTINET
FortiWiFi 60Fxxxxxx; FWF-60Fxxxxxx;

Model No.: FORTIWIFI-60Fxxxxxx; FortiWiFi 61Fxxxxxx;
FWF-61Fxxxxxx; FORTIWIFI-61Fxxxxxx;
(where “x” can be used “A-Z”, or “0-9”, or “-“, or blank for software purposes or marketing purposes only)

Model Difference: 61 series had SSD

FCC ID: TVE-121757A



Date of test: 2019/09/09 ~ 2020/01/16

Date of EUT Received: 2019/09/09

We hereby certify that:

All the tests in this report have been performed and recorded in accordance with the standards described above and performed by an independent electromagnetic compatibility consultant, International Standards Laboratory Corp.

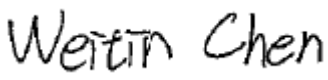
The test results contained in this report accurately represent the measurements of the characteristics and the energy generated by sample equipment under test at the time of the test. The sample equipment tested as described in this report is in compliance with the limits of above standards.

Test By:		Date:	2020/01/17
	<hr/>		<hr/>
	<i>Weitin Chen / Senior Engineer</i>		
Prepared By:		Date:	2020/01/17
	<hr/>		<hr/>
	<i>Gigi Yeh / Senior Engineer</i>		
Approved By:		Date:	2020/01/17
	<hr/>		<hr/>
	<i>Jerry Liu / Technical Manager</i>		

Version

Version No.	Date	Description
00	2020/01/17	Initial creation of document

Uncertainty of Measurement

ISO/IEC 17025 requires that an estimate of measurement uncertainties associated with the emissions test results be included in the report. The measurement uncertainties given below are based on a 95% confidence level (based on a coverage factor (k=2)).

Description Of Test	Uncertainty
Conducted Emission (AC power line)	2.586 dB
Field Strength of Spurious Radiation	≤30MHz: 2.96dB 30-1GHz: 4.22 dB 1-40 GHz: 4.08 dB
Conducted Power	2.412 GHz: 1.30 dB 5.805 GHz: 1.55 dB
Power Density	2.412 GHz: 1.30 dB 5.805 GHz: 1.67 dB
Frequency	0.0032%
Time	0.01%
DC Voltage	1%

Table of Contents

1. General Information.....	6
1.1. Product Description	6
1.2. Related Submittal(s) / Grant (s)	10
1.3. Test Methodology	10
1.4. Test Facility.....	10
1.5. Special Accessories	10
1.6. Equipment Modifications.....	10
2. System Test Configuration.....	11
2.1. EUT Configuration	11
2.2. EUT Exercise	11
2.3. Test Procedure.....	11
2.4. Configuration of Tested System.....	12
2.5. Duty Cycle	14
3. Summary of Test Results.....	18
4. Description of Test Modes.....	19
5. Conduced Emission Test	20
5.1. Standard Applicable	20
5.2. Measurement Equipment Used:	20
5.3. EUT Setup:.....	20
5.4. Measurement Procedure:	21
5.5. Measurement Result:	21
6. Output Power / EIRP /Spectral Density Measurement.....	24
6.1. Standard Applicable	24
6.2. Measurement Procedure.....	26
6.3. Measurement Equipment Used:	27
6.4. Measurement Equipment Used:	27
6.5. Measurement Result.....	28
7. 26dB /99% Emission Bandwidth Measurement.....	47
7.1. Standard Applicable	47
7.2. Measurement Procedure.....	47
7.3. Measurement Equipment Used:	47
7.4. Test Set-up:	47
7.5. Measurement Result.....	48
8. 6dB Emission Bandwidth Measurement.....	56
8.1. Standard Applicable	56
8.2. Measurement Procedure.....	56
8.3. Measurement Equipment Used:	56

8.4.	Test Set-up:	56
8.5.	Measurement Result.....	57
9.	Undesirable Emission – Radiated Measurement	65
9.1.	Standard Applicable	65
9.2.	EUT Setup.....	67
9.3.	Measurement Procedure.....	68
9.4.	Test SET-UP (Block Diagram of Configuration)	69
9.5.	Measurement Equipment Used:	70
9.6.	Field Strength Calculation	71
9.7.	Measurement Result.....	71
10.	Transmission in the Absence of Data	138
10.1.	Standard Applicable	138
10.2.	Result:	138
11.	Antenna Requirement	139
11.1.	Standard Applicable	139
11.2.	Antenna Connected Construction	139

1. General Information

1.1. Product Description

General:

Product Name	FortiWiFi 61F, FortiWiFi 60F	
Brand Name	FORTINET	
Model Name	FortiWiFi 60Fxxxxxx; FWF-60Fxxxxxx; FORTIWIFI-60Fxxxxxx; FortiWiFi 61Fxxxxxx; FWF-61Fxxxxxx; FORTIWIFI-61Fxxxxxx; (where “x” can be used “A-Z”, or “0-9”, or “-“, or blank for soft- ware purposes or marketing purposes only)	
Model Difference	61 series had SSD	
USB Port	One provided for Data link	
Console port	One provided for Data link	
WAN port	TWO provided for Data link	
DMZ Port	One provided for Data link	
LAN Port	Seven provided for Data link	
Power Tolerance:	+/- 1 dB	
Power Supply	12Vdc from Adapter	
	Adapter: FSP	Model: FSP036-RHBN3

Test SoftWare Version	QSPR v5.0-00071				
RF power setting in TEST SoftWare	Mode	Freq(MHz)	Power Setting		
			CDD	BF	
	802.11a	5180	19		
		5200	20		
		5240	19		
		5745	21.5		
		5785	22		
		5825	21		
	802.11n HT20	5180	20	19	
		5200	21	20	
		5240	21	20	
		5745	21.5	20.5	
		5785	22	21.5	
		5825	21	20	
	802.11n HT40	5190	17	16	
		5230	21	20	
		5755	20	19	
		5795	20	19	
	802.11ac VHT20	5180	20	19	
		5200	21	20	
		5240	21	20	
		5745	21.5	20.5	
		5785	22	21.5	
		5825	21	20	
	802.11ac VHT40	5190	17	16	
		5230	21	20	
		5755	20	19	
		5795	20	19	
	802.11ac VHT80	5210	16	15	
		5775	15	14	

5GHz WLAN: 3TX/3RX

Wi-Fi	Frequency Range (MHz)	Channels	Peak / Average Rated Power	Modulation Technology	
802.11a	5180 – 5240(NII)	4	23.09dBm (AV)	OFDM	
	5745 – 5825(NII)	5	25.38dBm (AV)		
802.11n	HT20 5180 – 5240(NII)	4	23.77dBm (AV)		
	HT20 5745 – 5825(NII)	5	26.39dBm (AV)		
	HT40 5190 – 5230(NII)	2	23.76dBm (AV)		
	HT40 5755 – 5795(NII)	2	23.75dBm (AV)		
802.11ac	VHT20 5180 – 5240(NII)	4	24.06dBm (AV)		
	VHT20 5745 – 5825(NII)	5	24.82dBm (AV)		
	VHT40 5190 – 5230(NII)	2	23.83dBm (AV)		
	VHT40 5755 – 5795(NII)	2	23.80dBm (AV)		
	VHT80 5210(NII)	1	18.94dBm (AV)		
	VHT80 5775(NII)	1	18.65dBm (AV)		
Modulation type		CCK, DQPSK, DBPSK for DSSS 256QAM.64QAM. 16QAM, QPSK, BPSK for OFDM			
Antenna Designation		Dipole Antenna Mode name: W1800R WiFi 5G Antenna for UNII-1: 3.06 dBi WiFi 5G Antenna for UNII-3: 3.58 dBi			

The EUT is compliance with IEEE 802.11 a/n/ac Standard.

This report applies for Wifi frequency band 5150 MHz– 5250 MHz, 5725 MHz– 5850 MHz

Remark: The above DUT's information was declared by manufacturer. Please refer to the specifications or user's manual for more detailed description.

TX Parameter

Modulation Mode	CDD Mode	Beamforming Mode	MIMO
802.11a	Support	NA	3TX
802.11n	Support	Support	3TX
802.11ac	Support	Support	3TX

Channel List

Frequency Band	Modulation Mode	Channel No.	Frequency (MHz)
5150 - 5250 MHz	802.11a	CH 36	5180
	802.11n HT20	CH 40	5200
	802.11ac VHT20	CH 44	5220
		CH 48	5240
	802.11n HT40	CH 38	5190
	802.11ac VHT40	CH 46	5230
5725 - 5850 MHz	802.11ac VHT80	CH 42	5210
	802.11a	CH 149	5745
	802.11n HT20	CH 153	5765
	802.11ac VHT20	CH 157	5785
		CH 161	5805
		CH 165	5825
	802.11n HT40	CH 151	5755
802.11ac VHT40	CH 159	5795	
	CH 155	5775	

Remark: The above DUT's information was declared by manufacturer. Please refer to the specifications or user's manual for more detailed description.

1.2. Related Submittal(s) / Grant (s)

This submittal(s) (test report) is intended for **FCC ID: TVE-121757A** filing to comply with Section 15.407 of the FCC Part 15, Subpart E Rules.

1.3. Test Methodology

Both conducted and radiated testing were performed according to the procedures in ANSI C63.10: 2013. Radiated testing was performed at an antenna to EUT distance 3 meters.

KDB Document: 789033 D02 General UNII Test Procedures New Rules v02r01

FCC 14-30 Revision UNII

594280 D02 U-NII Device Security v01r03

1.4. Test Facility

The measurement facilities used to collect the 3m Radiated Emission and AC power line conducted data are located on the address of International Standards Laboratory Corp. <LT Lab.> No. 120, Lane 180, Hsin Ho Rd., Lung-Tan Dist., Tao Yuan City 325, Taiwan which are constructed and calibrated to meet the FCC requirements in documents ANSI C63.10: 2013. FCC Registration Number is: 487532; Designation Number is: TW0997, Canada Registration Number: 4067B-4.

1.5. Special Accessories

Not available for this EUT intended for grant.

1.6. Equipment Modifications

Not available for this EUT intended for grant.

2. System Test Configuration

2.1. EUT Configuration

The EUT configuration for testing is installed on RF field strength measurement to meet the Commissions requirement and operating in a manner which intends to maximize its emission characteristics in a continuous normal application.

2.2. EUT Exercise

The EUT (Transmitter) was operated in the engineering mode to fix the Tx frequency that was for the purpose of the measurements.

2.3. Test Procedure

2.3.1 Conducted Emissions

The EUT is a placed on as turn table which is 0.8 m above ground plane. According to the requirements in Section 6 of ANSI C63.10: 2013. Con-ducted emissions from the EUT measured in the frequency range between 0.15 MHz and 30MHz using CISPR 16-1-1 Quasi-Peak and Average detector mode.

2.3.2 Radiated Emissions

The EUT is a placed on as turn table which is 0.8 m/1.5m (Frequency above 1GHz) above ground plane. The turn table shall rotate 360 degrees to determine the position of maximum emission level. EUT is set 3m away from the receiving antenna which varied from 1m to 4m to find out the highest emission. And also, each emission was to be maximized by changing the polarization of receiving antenna both horizontal and vertical. In order to find out the max. emission, the relative positions of this hand-held transmitter (EUT) was rotated through three orthogonal axes and measurement procedures for electric field radiated emissions above 1 GHz the EUT measurement is to be made “while keeping the antenna in the ‘cone of radiation’ from that area and pointed at the area both in azimuth and elevation, with polarization oriented for maximum response.” is still within the 3dB illumination BW of the measurement antenna according to the requirements in Section 6 and 11 of ANSI C63.10: 2013

2.4. Configuration of Tested System

Fig. 2-1 Configuration of Tested System

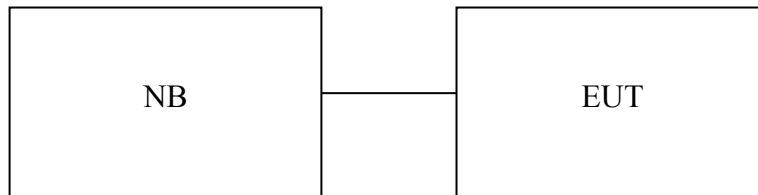

Table 1-1 Equipment Used in Tested System

Item	Equipment	Mfr/Brand	Model/ Type No.	Series No.	Data Cable	Power Cord
1	NB	ASUS	P2420L	NA	Non-Shielding	Non-Shielding

AC Conduction

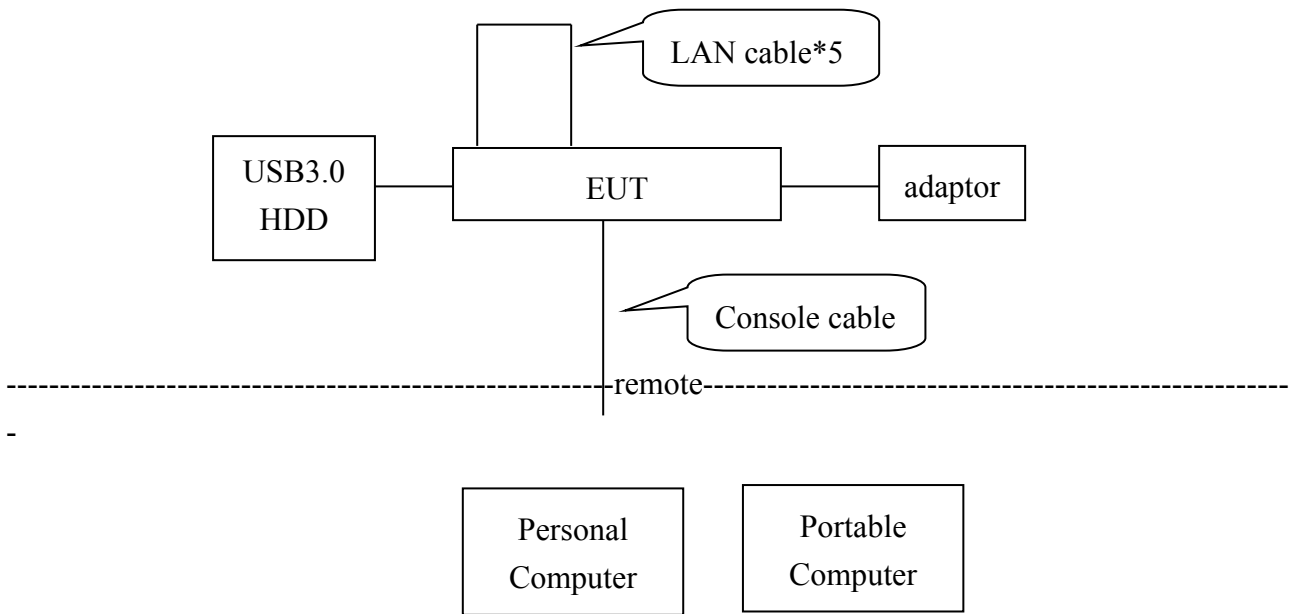

Table 2-1 Equipment Used in Tested System

Item	Equipment	Mfr/Brand	Model/ Type No.	Series No.	Data Cable	Power Cord
1	USB3.0 HDD	AKiTiO	SK2-U31AS-AKT	N/A	Shielded /1m	N/A
2	Portable Computer	DELL	P18S	6VWSKT1	N/A	Non-shielded /1.8m
3	Personal Computer	Lenovo	5PV	P834EW3	N/A	Non-shield / 1.8m
4	Traveling Disk (3.0)	Transcend	TS16GJF700	N/A	Shielded /1.27m	N/A

2.5. Duty Cycle

If duty cycle of test signal is $\geq 98\%$, duty factor is not required.

If duty cycle of test signal is $< 98\%$, duty factor shall be considered.

The output power = measured power + duty factor.

Mode	ON time	Total time	Duty Cycle	Duty Factor	VBW for average detector ($\geq 1/T_{on}$)
802.11 a	2.012	2.120	94.906%	0.23	1kHz
802.11n HT20	3.752	3.880	96.701%	0.15	1kHz
802.11n HT40	1.784	1.920	92.917%	0.32	1kHz
802.11ac VHT20	3.730	3.840	97.135%	0.13	1kHz
802.11ac VHT40	1.770	1.915	92.428%	0.34	1kHz
802.11ac VHT80	0.824	0.970	84.948%	0.71	2kHz

802.11a

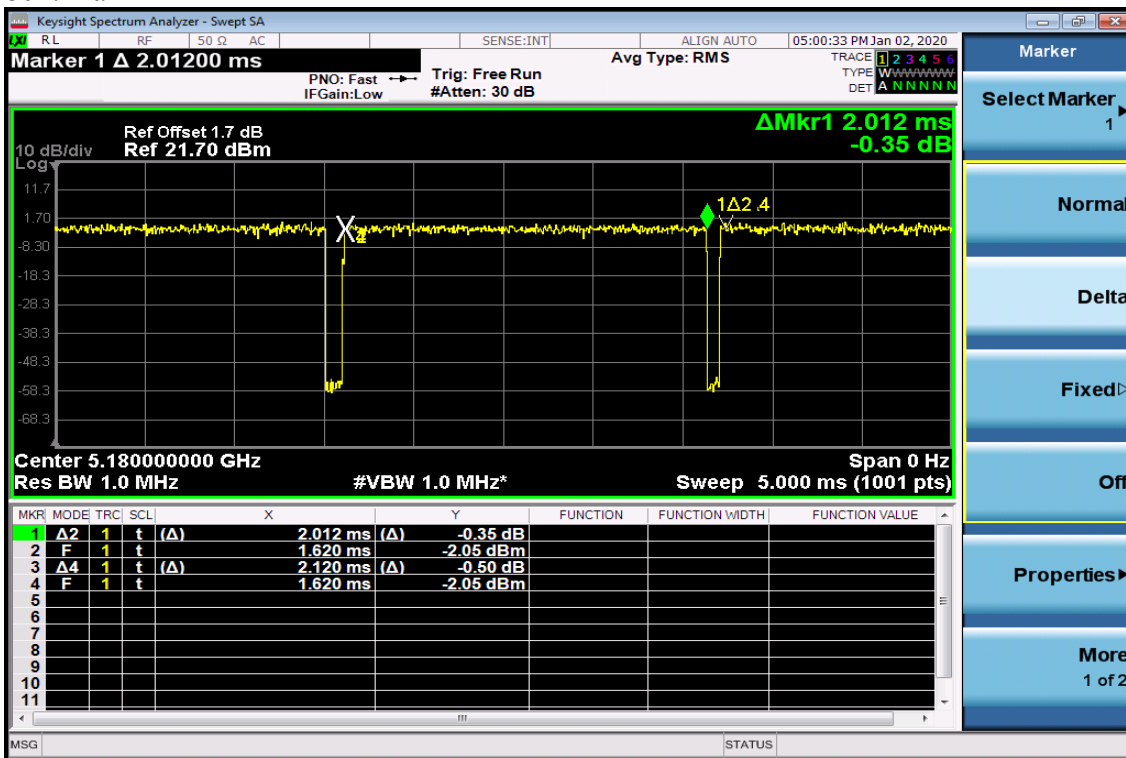

802.11n HT20

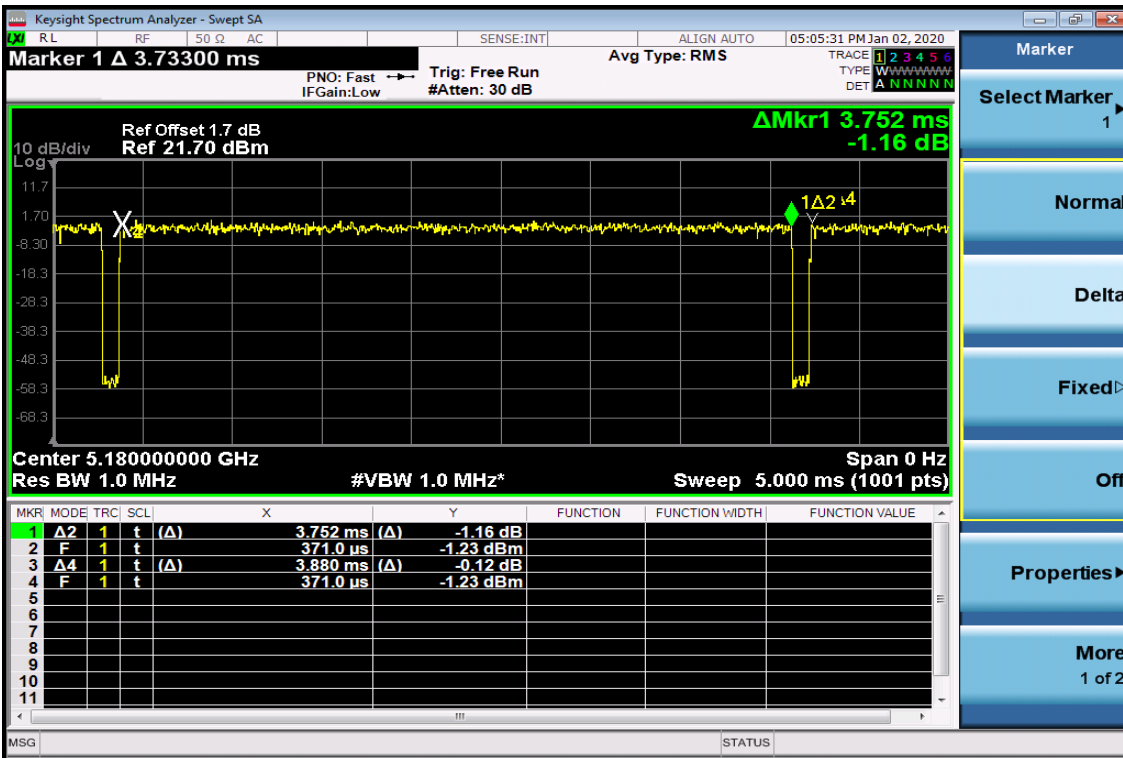

802.11n HT40

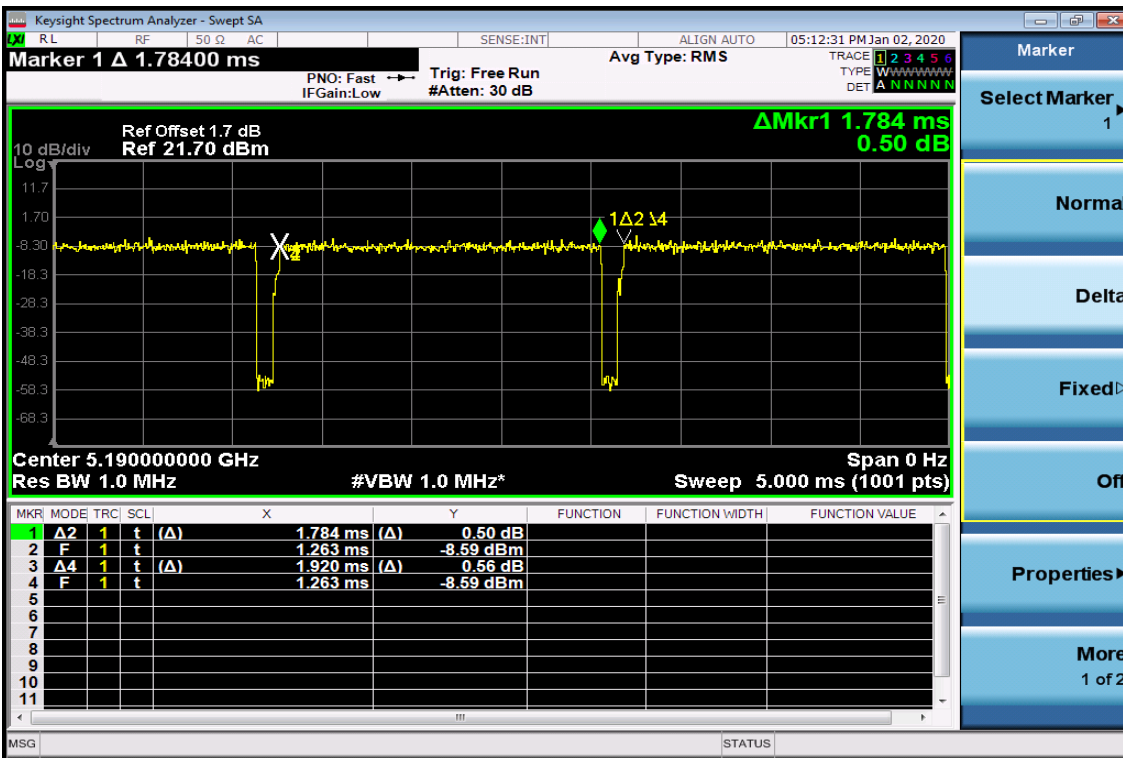

802.11ac VHT20

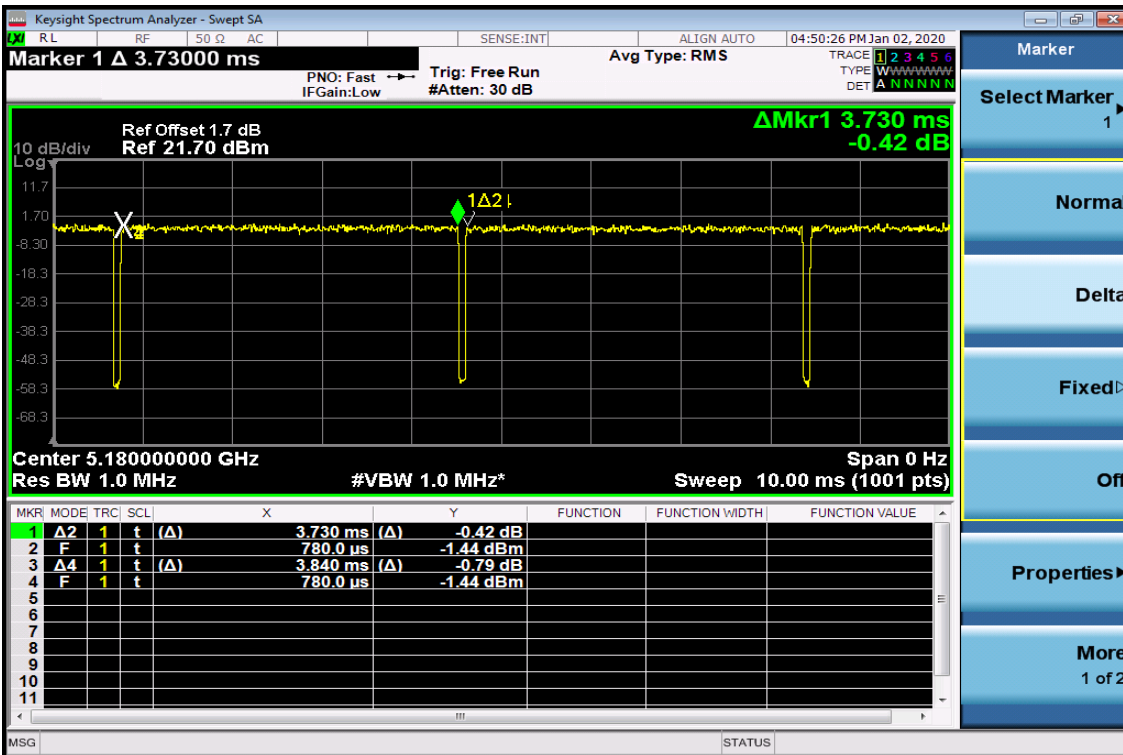

802.11 ac VHT40

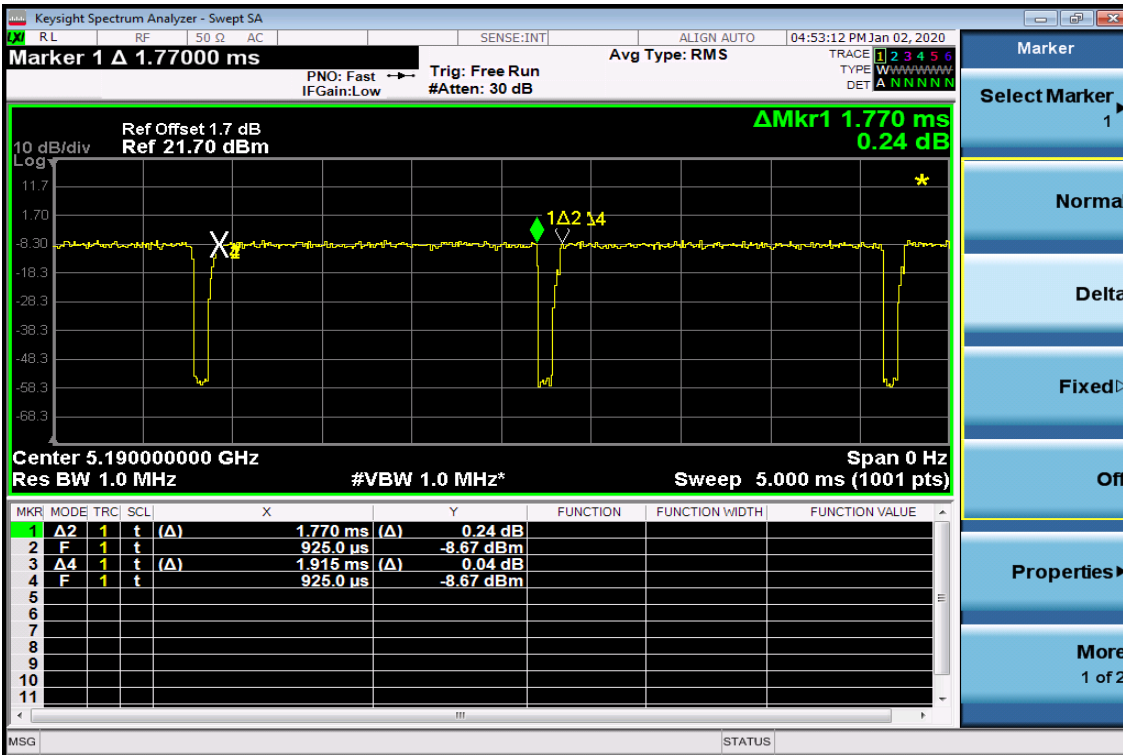

802.11ac VHT80

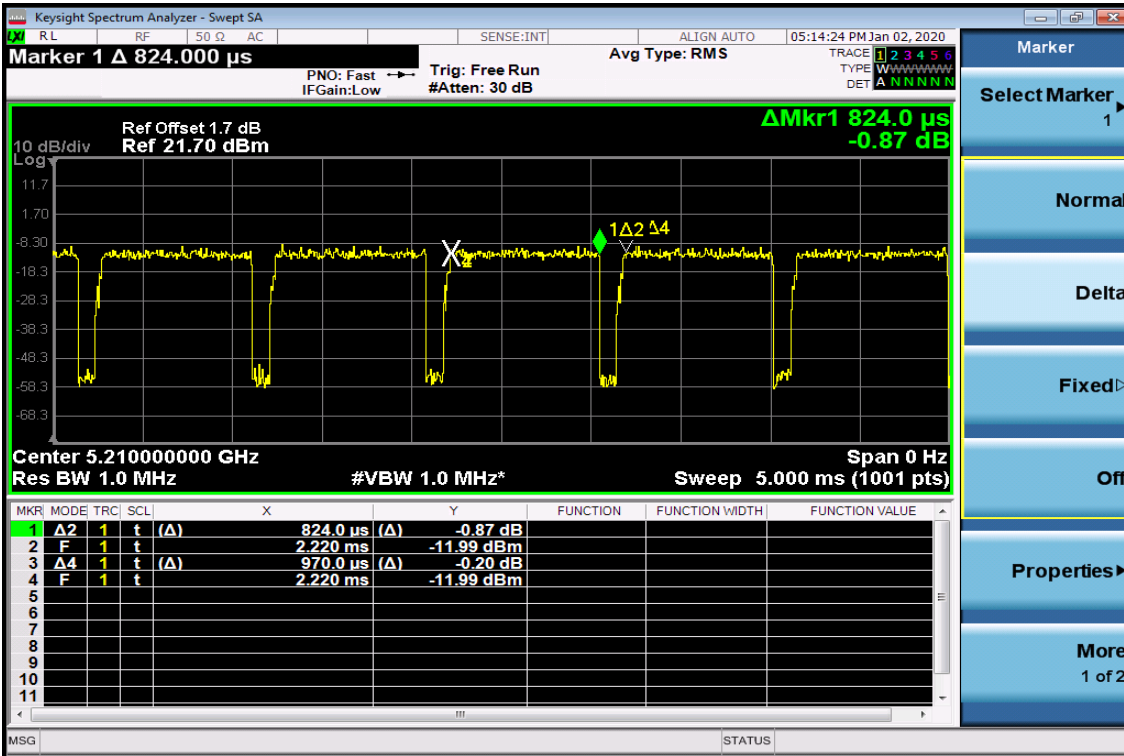

3. Summary of Test Results

FCC Rules	Description Of Test	Result
§15.207	AC Power Line Conducted Emission	Compliant
§15.407(a)(2)	Output Power/ EIRP/ Spectral Density Measurement	Compliant
§15.407(a)	26dB Emission Bandwidth	Compliant
§15.407(e)	6dB Emission Bandwidth	Compliant
§15.407(b)	Undesirable Emission – Radiated Measurement	Compliant
§15.407(g)	Frequency Stability	Compliant
§15.407(a)	Antenna Requirement	Compliant

4. Description of Test Modes

The EUT has been tested under operating condition.

Test program used to control the EUT for staying in continuous transmitting mode is programmed.

The modulation and bandwidth are similar for 802.11n mode for 20MHz/40MHz and 802.11ac mode for 20MHz/40MHz, therefore investigated worst case to representative mode in test report.

For 802.11n and 802.11ac, CDD mode and Beamforming mode are presented in power output test item. For other test items, CDD mode is the worst case for final tests after pretesting. Pre-Scan has been conducted to determine the worst-case mode from all possible combinations between available modulations, data rates and antenna ports (if EUT with antenna diversity architecture).

Following channels were selected for the final test as listed below.

Frequency Band (MHz)	Modulation Mode	Test Channel	Data Rate (Mbps)
5180 - 5240	802.11a	36, 40, 48	6
	802.11n HT20	36, 40, 48	6.5
	802.11n HT40	38, 46	13.5
	802.11ac VHT80	42	29.3
5725 - 5850	802.11a	149, 157, 165	6
	802.11n HT20	149, 157, 165	6.5
	802.11n HT40	151, 159	13.5
	802.11ac VHT80	155	29.3

$$\text{Directional gain} = G_{ANT} + 10 \log(N_{ANT}) \text{ dBi}$$

5. Conduced Emission Test

5.1. Standard Applicable

According to §15.207, frequency range within 150kHz to 30MHz shall not exceed the Limit table as below.

Frequency range MHz	Limits dB(uV)	
	Quasi-peak	Average
0.15 to 0.50	66 to 56	56 to 46
0.50 to 5	56	46
5 to 30	60	50

Note

- 1.The lower limit shall apply at the transition frequencies
- 2.The limit decreases linearly with the logarithm of the frequency in the range 0.15 MHz to 0.50 MHz.

5.2. Measurement Equipment Used:

Location	Equipment Name	Brand	Model	S/N	Last Cal. Date	Next Cal. Date
Conduction 02	LISN 26	R&S	ENV216	102378	11/21/2018	11/21/2019
Conduction 02	LISN 20	R&S	ENV216	101477	07/31/2019	07/31/2020
Conduction 02	Conduction 02-1 Cable	WOKEN	CFD 300-NL	Conduction 02 -1	09/11/2018	09/11/2019
Conduction 02	Conduction 02-1 Cable	WOKEN	CFD 300-NL	Conduction 02 -1	09/11/2019	09/11/2020
Conduction 02	EMI Receiver 14	ROHDE& SCHWARZ	ESCI	101034	05/31/2019	05/31/2020
Conduction 02	ISN T8 10	Teseq GmbH	ISN T800	42773	08/02/2019	08/02/2020
Conduction 02	Capacitive Voltage Probe	FCC	F-CVP-1	68	02/19/2019	02/19/2020
Conduction 02	Current Probe	SCHAFFNER	SMZ 11	18030	02/19/2019	02/19/2020

5.3. EUT Setup:

1. The conducted emission tests were performed in the test site, using the setup in accordance with the ANSI C63.10: 2013.
2. The AC/DC Power adaptor of EUT was plug-in LISN. The EUT was placed flushed with the rear of the table.
3. The LISN was connected with power source.

5.4. Measurement Procedure:

1. The EUT was placed on a table which is 0.8m above the ground plane.
2. A maximum procedure was performed on the six highest emissions to ensure EUT compliance.
3. Repeat the procedures above until all frequency measured were complete.
4. Both 120V & 240V have been verified, and 120V/60Hz was defined as the worst-case and record in the report.

5.5. Measurement Result:

The initial step in collecting conducted data is a spectrum analyzer peak scan of the measurement range. Significant peaks are then marked as shown on the following data page, and these signals are then quasi-peaked.

Note: Refer to next page for measurement data and plots.

AC POWER LINE CONDUCTED EMISSION TEST DATA

Operation Mode: Full mode (Worst Data)	Test Date: 2019/09/10
--	-----------------------



Address: No. 120, Lane 180, Hsin Ho Rd., Lung-Tan Dist.,
Tao Yuan City 325, Taiwan.
Tel: 03-4071718

Conducted Emission Measurement

operator: James Kuo
Temperature: 26 °C
Humidity: 60 %

Date: 2019/9/10

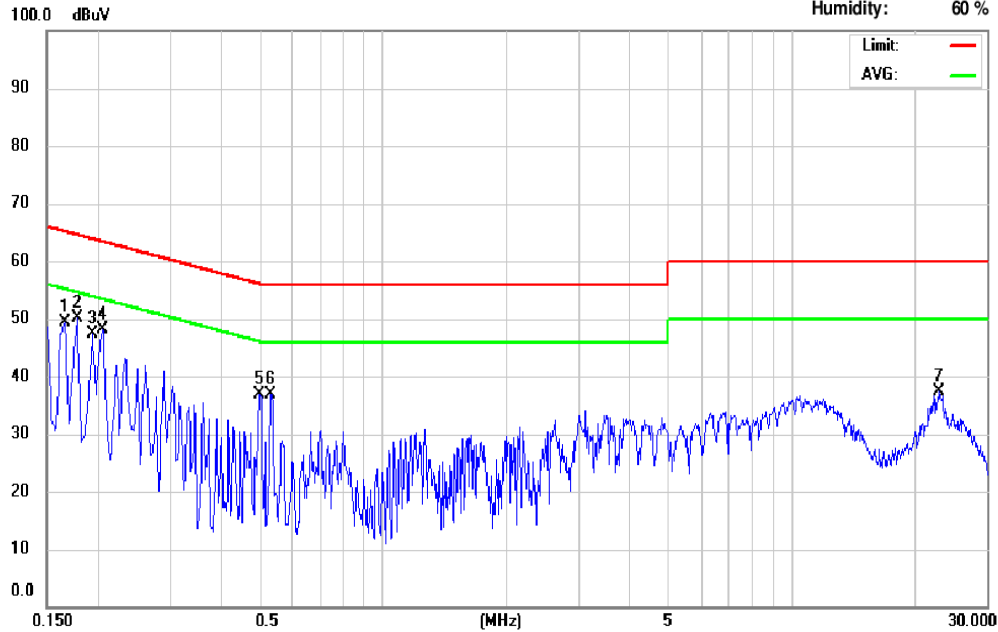

Site: Conduction 02

Phase: L1

No.	Frequency (MHz)	QP_R (dBuV)	AVG_R (dBuV)	Correct Factor (dB)	QP Emission (dBuV)	QP Limit (dBuV)	QP Margin (dB)	AVG Emission (dBuV)	AVG Limit (dBuV)	AVG Margin (dB)
1	0.166	40.49	27.38	9.63	50.12	65.16	-15.04	37.01	55.16	-18.15
2	0.178	33.15	16.37	9.62	42.77	64.58	-21.81	25.99	54.58	-28.59
3	0.194	33.89	22.60	9.62	43.51	63.86	-20.35	32.22	53.86	-21.64
4	0.206	33.03	21.89	9.62	42.65	63.37	-20.72	31.51	53.37	-21.86
5	0.498	26.98	26.82	9.64	36.62	56.03	-19.41	36.46	46.03	-9.57
6	0.530	26.90	25.49	9.64	36.54	56.00	-19.46	35.13	46.00	-10.87
7	22.938	21.57	14.19	9.90	31.47	60.00	-28.53	24.09	50.00	-25.91



Address: No. 120, Lane 180, Hsin Ho Rd., Lung-Tan Dist.,
Tao Yuan City 325, Taiwan.
Tel: 03-4071718

Conducted Emission Measurement

Date: 2019/9/10

operator: James Kuo

Temperature: 26 °C

Humidity: 60 %

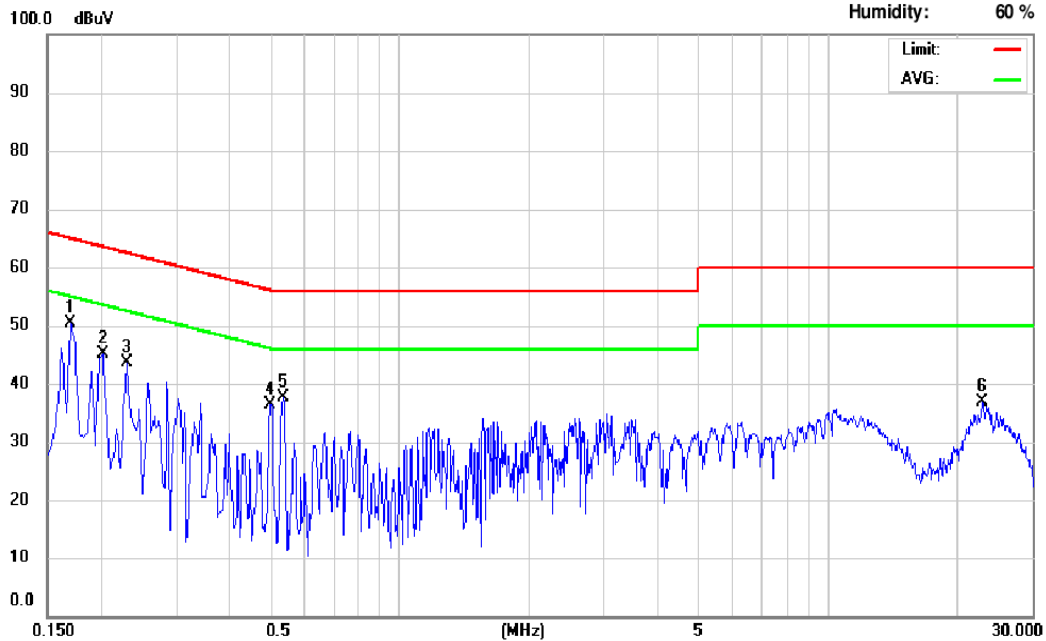

Site: Conduction 02

Phase: N

No.	Frequency (MHz)	QP_R (dBuV)	AVG_R (dBuV)	Correct Factor (dB)	QP Emission (dBuV)	QP Limit (dBuV)	QP Margin (dB)	AVG Emission (dBuV)	AVG Limit (dBuV)	AVG Margin (dB)
1	0.170	39.09	26.71	9.64	48.73	64.96	-16.23	36.35	54.96	-18.61
2	0.202	36.33	26.28	9.64	45.97	63.53	-17.56	35.92	53.53	-17.61
3	0.230	32.25	23.08	9.64	41.89	62.45	-20.56	32.72	52.45	-19.73
4	0.498	26.00	25.89	9.65	35.65	56.03	-20.38	35.54	46.03	-10.49
5	0.534	27.09	26.59	9.65	36.74	56.00	-19.26	36.24	46.00	-9.76
6	22.934	20.90	13.42	10.02	30.92	60.00	-29.08	23.44	50.00	-26.56

6. Output Power / EIRP /Spectral Density Measurement

6.1. Standard Applicable

According to §15.407(a) Power limits:

- (1) For the band 5.15 - 5.25 GHz.
 - (i) For an outdoor access point operating in the band 5.15 - 5.25 GHz, the maximum conducted output power over the frequency band of operation shall not exceed 1 W provided the maximum antenna gain does not exceed 6 dBi. In addition, the maximum power spectral density shall not exceed 17 dBm in any 1 megahertz band. If transmitting antennas of directional gain greater than 6 dBi are used, both the maximum conducted output power and the maximum power spectral density shall be reduced by the amount in dB that the directional gain of the antenna exceeds 6 dBi. The maximum e.i.r.p. at any elevation angle above 30 degrees as measured from the horizon must not exceed 125 mW (21 dBm).
 - (ii) For an indoor access point operating in the band 5.15 - 5.25 GHz, the maximum conducted output power over the frequency band of operation shall not exceed 1 W provided the maximum antenna gain does not exceed 6 dBi. In addition, the maximum power spectral density shall not exceed 17 dBm in any 1 megahertz band. If transmitting antennas of directional gain greater than 6 dBi are used, both the maximum conducted output power and the maximum power spectral density shall be reduced by the amount in dB that the directional gain of the antenna exceeds 6 dBi.
 - (iii) For fixed point-to-point access points operating in the band 5.15 - 5.25 GHz, the maximum conducted output power over the frequency band of operation shall not exceed 1 W. Fixed point-to-point U-NII devices may employ antennas with directional gain up to 23 dBi without any corresponding reduction in the maximum conducted output power or maximum power spectral density. For fixed point-to-point transmitters that employ a directional antenna gain greater than 23 dBi, a 1 dB reduction in maximum conducted output power and maximum power spectral density is required for each 1 dB of antenna gain in excess of 23 dBi. Fixed, point-to-point operations exclude the use of point-to-multipoint systems, omnidirectional applications, and multiple collocated transmitters transmitting the same information. The operator of the U-NII device, or if the equipment is professionally installed, the installer, is responsible for ensuring that systems employing high gain directional antennas are used exclusively for fixed, point-to-point operations.

- (iv) For mobile and portable client devices in the 5.15 - 5.25 GHz band, the maximum conducted output power over the frequency band of operation shall not exceed 250 mW provided the maximum antenna gain does not exceed 6 dBi. In addition, the maximum power spectral density shall not exceed 11 dBm in any 1 megahertz band. If transmitting antennas of directional gain greater than 6 dBi are used, both the maximum conducted output power and the maximum power spectral density shall be reduced by the amount in dB that the directional gain of the antenna exceeds 6 dBi.
- (2) For the 5.25 - 5.35 GHz and 5.47 - 5.725 GHz bands, the maximum conducted output power over the frequency bands of operation shall not exceed the lesser of 250 mW or $11 \text{ dBm} + 10 \log B$, where B is the 26 dB emission bandwidth in megahertz. In addition, the maximum power spectral density shall not exceed 11 dBm in any 1 megahertz band. If transmitting antennas of directional gain greater than 6 dBi are used, both the maximum conducted output power and the maximum power spectral density shall be reduced by the amount in dB that the directional gain of the antenna exceeds 6 dBi.
- (3) For the band 5.725 - 5.85 GHz, the maximum conducted output power over the frequency band of operation shall not exceed 1 W. In addition, the maximum power spectral density shall not exceed 30 dBm in any 500 kHz band. If transmitting antennas of directional gain greater than 6 dBi are used, both the maximum conducted output power and the maximum power spectral density shall be reduced by the amount in dB that the directional gain of the antenna exceeds 6 dBi. However, fixed point-to-point U-NII devices operating in this band may employ transmitting antennas with directional gain greater than 6 dBi without any corresponding reduction in transmitter conducted power. Fixed, point-to-point operations exclude the use of point-to-multipoint systems, omnidirectional applications, and multiple collocated transmitters transmitting the same information. The operator of the U-NII device, or if the equipment is professionally installed, the installer, is responsible for ensuring that systems employing high gain directional antennas are used exclusively for fixed, point-to-point operations.

6.2. Measurement Procedure

For Output Power

1. Place the EUT on the table and set it in transmitting mode.
2. Remove the antenna from the EUT and then connect a low loss RF cable from the antenna port to the power meter
3. Record the max. reading.
4. Repeat above procedures until all frequency measured were complete.

For Power Spectral Density

1. Set span to encompass the entire EBW of the signal.
2. Set RBW = 1 MHz.
3. Set VBW \geq 3 MHz
4. Number of points in sweep $\geq 2 \times \text{span} / \text{RBW}$.
5. Sweep time \leq (number of points in sweep) \times T, where T is refers to the minimum transmission duration over which the transmitter is on and is transmitting at its maximum power control level for the tested mode of operation.
6. Detector = power averaging (rms).
7. Trace mode = max hold.
8. Allow max hold to run for at least 60 seconds, or longer as needed to allow the trace to stabilize. Use the peak search function on the instrument to find the peak of the spectrum and record its value.

Refer to KDB Document: KDB 789033 D02 General UNII Test Procedures New Rules v02r01

6.3. Measurement Equipment Used:

Location Conducted	Equipment Name	Brand	Model	S/N	Last Cal. Date	Next Cal. Date
Conducted	Power Meter	Anritsu	ML2495A	1116010	10/04/2019	10/04/2020
Conducted	Power Sensor	Anritsu	MA2411B	34NKF50	10/04/2019	10/04/2020
Conducted	Power Sensor	DARE	RPR3006W	13I00030SNO33	01/11/2019	01/11/2020
Conducted	Power Sensor	DARE	RPR3006W	14I00889SNO35	06/27/2019	06/27/2020
Conducted	Power Sensor	DARE	RPR3006W	14I00889SNO36	06/27/2019	06/27/2020
Conducted	Temperature Chamber	KSON	THS-B4H100	2287	02/19/2019	02/19/2020
Conducted	DC Power supply	ABM	8185D	N/A	01/10/2019	01/10/2020
Conducted	AC Power supply	EXTECH	CFC105W	NA	N/A	N/A
Conducted	Spectrum analyzer	Keysight	N9010A	MY56070257	10/05/2019	10/05/2020
Conducted	Spectrum analyzer	R&S	FSP40	100116	01/10/2019	01/10/2020
Conducted	Test Software	DARE	Radiation Ver:2013.1.23	NA	NA	NA
Conducted	Test Software	R&S	CMUGO Ver:2.0.0	N/A	N/A	N/A
Conducted	Radio Communication Analyzer	R&S	CMU200	111968	10/29/2019	10/29/2020
Conducted	Radio Communication Analyzer	R&S	CMW500	1201.002K50108 793-JG	10/11/2019	10/11/2020
Conducted	BT Simulator	Agilent	N4010A	MY48100200	NA	NA
Conducted	GPS Simulator	Welnavigate	GS-50	701523	NA	NA

6.4. Measurement Equipment Used:

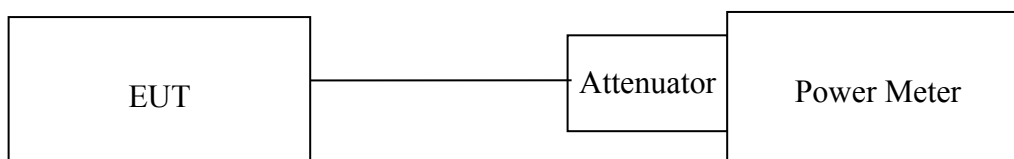

6.5. Measurement Result

CDD mode

Mode	Band	Freq. (MHz)	Output Power (dBm)			Duty Factor (dB)	Total Output Power (dBm)	Output Power Limit (dBm)
			Chain 0	Chain 1	Chain 2			
802.11a	UNII-1	5180	16.87	17.24	17.33	0.23	22.15	30.00
		5200	17.74	18.13	18.39	0.23	23.09	30.00
		5240	17.62	18.14	18.46	0.23	23.09	30.00
	UNII-3	5745	19.58	20.24	21.18	0.23	25.38	30.00
		5785	19.5	20.01	20.95	0.23	25.19	30.00
		5825	19.62	19.31	20.69	0.23	24.91	30.00

Mode	Band	Freq. (MHz)	Output Power (dBm)			Duty Factor (dB)	Total Output Power (dBm)	Output Power Limit (dBm)
			Chain 0	Chain 1	Chain 2			
802.11n HT20	UNII-1	5180	17.77	17.99	18	0.15	22.84	30.00
		5200	18.45	19.1	18.99	0.15	23.77	30.00
		5240	18.43	19.05	18.87	0.15	23.71	30.00
	UNII-3	5745	19.53	19.98	20.93	0.15	25.10	30.00
		5785	20.17	20	23.37	0.15	26.39	30.00
		5825	19.34	19.21	20.59	0.15	24.68	30.00

Mode	Band	Freq. (MHz)	Output Power (dBm)			Duty Factor (dB)	Total Output Power (dBm)	Output Power Limit (dBm)
			Chain 0	Chain 1	Chain 2			
802.11n HT40	UNII-1	5190	14.03	14.78	14.87	0.32	19.67	30.00
		5230	18.36	18.57	19.05	0.32	23.76	30.00
	UNII-3	5755	18.11	18.07	19.37	0.32	23.65	30.00
		5795	18.4	17.9	19.51	0.32	23.75	30.00

Mode	Band	Freq. (MHz)	Output Power (dBm)			Duty Factor (dB)	Total Output Power (dBm)	Output Power Limit (dBm)
			Chain 0	Chain 1	Chain 2			
802.11ac VHT20	UNII-1	5180	17.64	17.98	17.83	0.13	22.72	30.00
		5200	18.52	19.77	19.12	0.13	24.06	30.00
		5240	18.19	19.87	19.21	0.13	24.04	30.00
	UNII-3	5745	19.42	19.63	20.13	0.13	24.63	30.00
		5785	20.06	19.72	19.98	0.13	24.82	30.00
		5825	19.22	19.07	20.13	0.13	24.40	30.00

Mode	Band	Freq. (MHz)	Output Power (dBm)			Duty Factor (dB)	Total Output Power (dBm)	Output Power Limit (dBm)
			Chain 0	Chain 1	Chain 2			
802.11ac VHT40	UNII-1	5190	14.37	14.93	14.56	0.34	19.74	30.00
		5230	18.42	18.47	19.21	0.34	23.83	30.00
	UNII-3	5755	18.42	18.32	19.25	0.34	23.80	30.00
		5795	18.23	17.13	19.22	0.34	23.39	30.00

Mode	Band	Freq. (MHz)	Output Power (dBm)			Duty Factor (dB)	Total Output Power (dBm)	Output Power Limit (dBm)
			Chain 0	Chain 1	Chain 2			
802.11ac VHT80	UNII-1	5210	12.77	13.74	13.81	0.71	18.94	30.00
	UNII-3	5775	12.78	12.83	13.82	0.71	18.65	30.00

Beamforming mode

Mode	Band	Freq. (MHz)	Output Power (dBm)			Duty Factor (dB)	Total Output Power (dBm)	Output Power Limit (dBm)
			Chain 0	Chain 1	Chain 2			
802.11n HT20	UNII-1	5180	16.24	16.98	17.21	0.15	21.75	28.17
		5200	17.46	18.22	17.62	0.15	22.70	28.17
		5240	17.6	17.65	17.81	0.15	22.60	28.17
	UNII-3	5745	18.09	18.83	19.65	0.15	23.82	27.65
		5785	19.2	18.45	21.02	0.15	24.61	27.65
		5825	18.14	18.41	19.88	0.15	23.80	27.65

Mode	Band	Freq. (MHz)	Output Power (dBm)			Duty Factor (dB)	Total Output Power (dBm)	Output Power Limit (dBm)
			Chain 0	Chain 1	Chain 2			
802.11n HT40	UNII-1	5190	13.09	13.83	14.09	0.32	18.78	28.17
		5230	17.18	17.46	18.39	0.32	22.80	28.17
	UNII-3	5755	17.49	17.15	18.22	0.32	22.73	27.65
		5795	17.51	16.42	18.77	0.32	22.76	27.65

Mode	Band	Freq. (MHz)	Output Power (dBm)			Duty Factor (dB)	Total Output Power (dBm)	Output Power Limit (dBm)
			Chain 0	Chain 1	Chain 2			
802.11ac VHT20	UNII-1	5180	16.03	16.85	16.97	0.13	21.53	28.17
		5200	17.48	17.89	17.34	0.13	22.47	28.17
		5240	16.89	16.52	16.55	0.13	21.55	28.17
	UNII-3	5745	17.93	18.29	19.12	0.13	23.37	27.65
		5785	18.79	18.48	20.78	0.13	24.37	27.65
		5825	18.27	18.31	19.56	0.13	23.65	27.65

Mode	Band	Freq. (MHz)	Output Power (dBm)			Duty Factor (dB)	Total Output Power (dBm)	Output Power Limit (dBm)
			Chain 0	Chain 1	Chain 2			
802.11ac VHT40	UNII-1	5190	13.21	13.73	14.13	0.34	18.82	28.17
		5230	17.06	17.21	18.12	0.34	22.60	28.17
	UNII-3	5755	17.31	17.02	18.01	0.34	22.58	27.65
		5795	17.27	16.21	18.37	0.34	22.49	27.65

Mode	Band	Freq. (MHz)	Output Power (dBm)			Duty Factor (dB)	Total Output Power (dBm)	Output Power Limit (dBm)
			Chain 0	Chain 1	Chain 2			
802.11ac VHT80	UNII-1	5210	11.9	12.77	12.43	0.71	17.86	28.17
	UNII-3	5775	11.32	11.33	12.5	0.71	17.23	27.65

Power Spectral Density Measurement:

CDD mode

802.11a

Band	Frequency (MHz)	PSD (dBm/MHz)			Duty Factor (dB)	Total PSD (dBm/MHz)	PSD Limit (dBm/MHz)
		Chain0	Chain1	Chain2			
UNII-1	5180	6.36	6.27	5.91	0.23	11.18	15.17
	5200	7.41	7.61	7.35	0.23	12.46	15.17
	5240	5.65	6.65	6.48	0.23	11.28	15.17

Band	Frequency (MHz)	PSD (dBm/500kHz)			Duty Factor (dB)	Total PSD (dBm/500kHz)	PSD Limit (dBm/500kHz)
		Chain0	Chain1	Chain2			
UNII-3	5745	8.13	9.49	10.54	0.23	14.49	27.65
	5785	9.13	8.73	9.48	0.23	14.12	27.65
	5825	7.36	8.39	7.83	0.23	12.88	27.65

802.11n HT20

Band	Frequency (MHz)	PSD (dBm/MHz)			Duty Factor (dB)	Total PSD (dBm/MHz)	PSD Limit (dBm/MHz)
		Chain0	Chain1	Chain2			
UNII-1	5180	5.51	5.70	5.37	0.15	10.44	15.17
	5200	6.39	6.54	6.37	0.15	11.35	15.17
	5240	5.56	6.68	6.54	0.15	11.21	15.17

Band	Frequency (MHz)	PSD (dBm/500kHz)			Duty Factor (dB)	Total PSD (dBm/500kHz)	PSD Limit (dBm/500kHz)
		Chain0	Chain1	Chain2			
UNII-3	5745	8.27	8.63	8.79	0.15	13.49	27.65
	5785	7.54	8.43	8.15	0.15	12.97	27.65
	5825	6.67	7.91	8.25	0.15	12.58	27.65

802.11n HT40

Band	Frequency (MHz)	PSD (dBm/MHz)			Duty Factor (dB)	Total PSD (dBm/MHz)	PSD Limit (dBm/MHz)
		Chain0	Chain1	Chain2			
UNII-1	5190	0.11	1.00	0.85	0.32	5.76	15.17
	5230	4.31	4.89	4.83	0.32	9.77	15.17

Band	Frequency (MHz)	PSD (dBm/500kHz)			Duty Factor (dB)	Total PSD (dBm/500kHz)	PSD Limit (dBm/500kHz)
		Chain0	Chain1	Chain2			
UNII-3	5755	3.31	4.62	4.77	0.32	9.37	27.65
	5795	4.82	3.74	4.83	0.32	9.58	27.65

802.11ac VHT20

Band	Frequency (MHz)	PSD (dBm/MHz)			Duty Factor (dB)	Total PSD (dBm/MHz)	PSD Limit (dBm/MHz)
		Chain0	Chain1	Chain2			
UNII-1	5180	5.73	5.74	5.36	0.13	10.51	15.17
	5200	6.16	6.67	6.53	0.13	11.35	15.17
	5240	5.48	6.76	6.66	0.13	11.23	15.17

Band	Frequency (MHz)	PSD (dBm/500kHz)			Duty Factor (dB)	Total PSD (dBm/500kHz)	PSD Limit (dBm/500kHz)
		Chain0	Chain1	Chain2			
UNII-3	5745	7.64	8.91	10.05	0.13	13.88	27.65
	5785	8.57	9.02	8.47	0.13	13.59	27.65
	5825	6.76	7.93	7.39	0.13	12.28	27.65

802.11ac VHT40

Band	Frequency (MHz)	PSD (dBm/MHz)			Duty Factor (dB)	Total PSD (dBm/MHz)	PSD Limit (dBm/MHz)
		Chain0	Chain1	Chain2			
UNII-1	5190	0.32	1.11	0.82	0.34	5.88	15.17
	5230	4.12	5.04	4.89	0.34	9.82	15.17

Band	Frequency (MHz)	PSD (dBm/500kHz)			Duty Factor (dB)	Total PSD (dBm/500kHz)	PSD Limit (dBm/500kHz)
		Chain0	Chain1	Chain2			
UNII-3	5755	4.63	4.50	4.78	0.34	9.75	27.65
	5795	3.79	4.26	4.86	0.34	9.44	27.65

802.11ac VHT80

Band	Frequency (MHz)	PSD (dBm/MHz)			Duty Factor (dB)	Total PSD (dBm/MHz)	PSD Limit (dBm/MHz)
		Chain0	Chain1	Chain2			
UNII-1	5210	-4.37	-3.00	-3.27	0.71	1.97	15.17

Band	Frequency (MHz)	PSD (dBm/500kHz)			Duty Factor (dB)	Total PSD (dBm/500kHz)	PSD Limit (dBm/500kHz)
		Chain0	Chain1	Chain2			
UNII-3	5775	-4.97	-3.05	-3.71	0.71	1.64	27.65

CDD mode

Test plot of CDD mode chain 0 for the representative.

Band UNII-1

802.11a

Power Spectral Density Data Plot (CH Low)

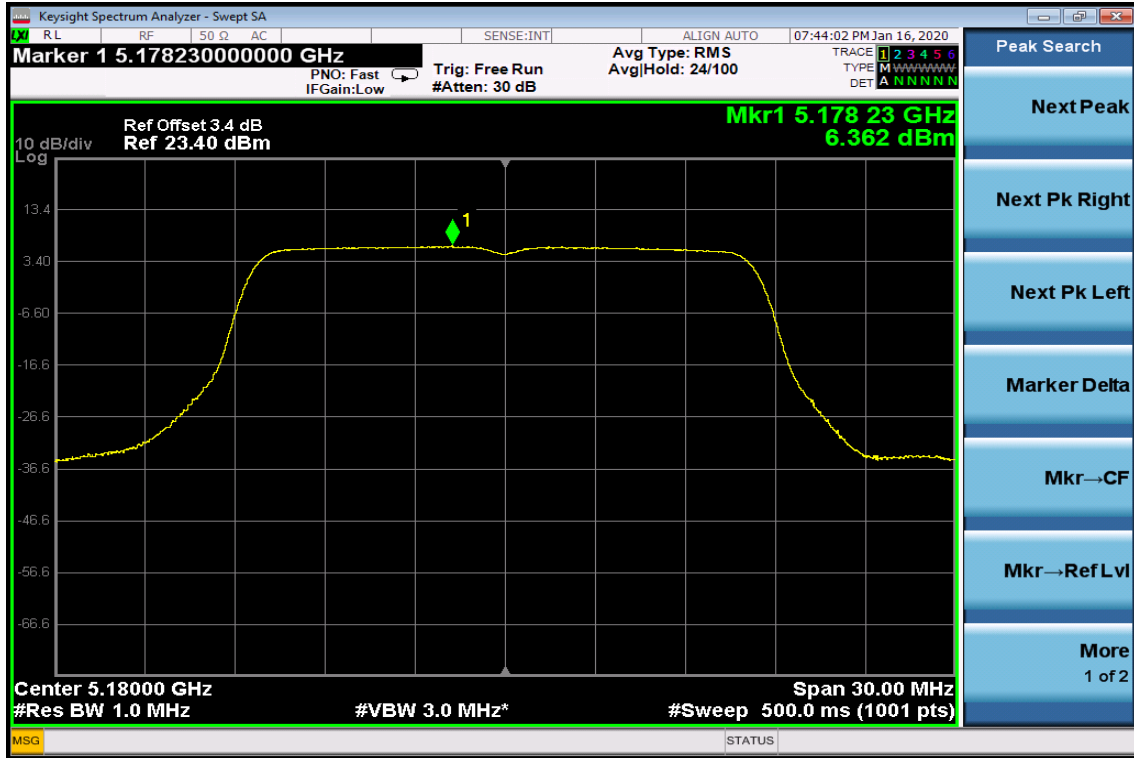

Power Spectral Density Data Plot (CH Mid)

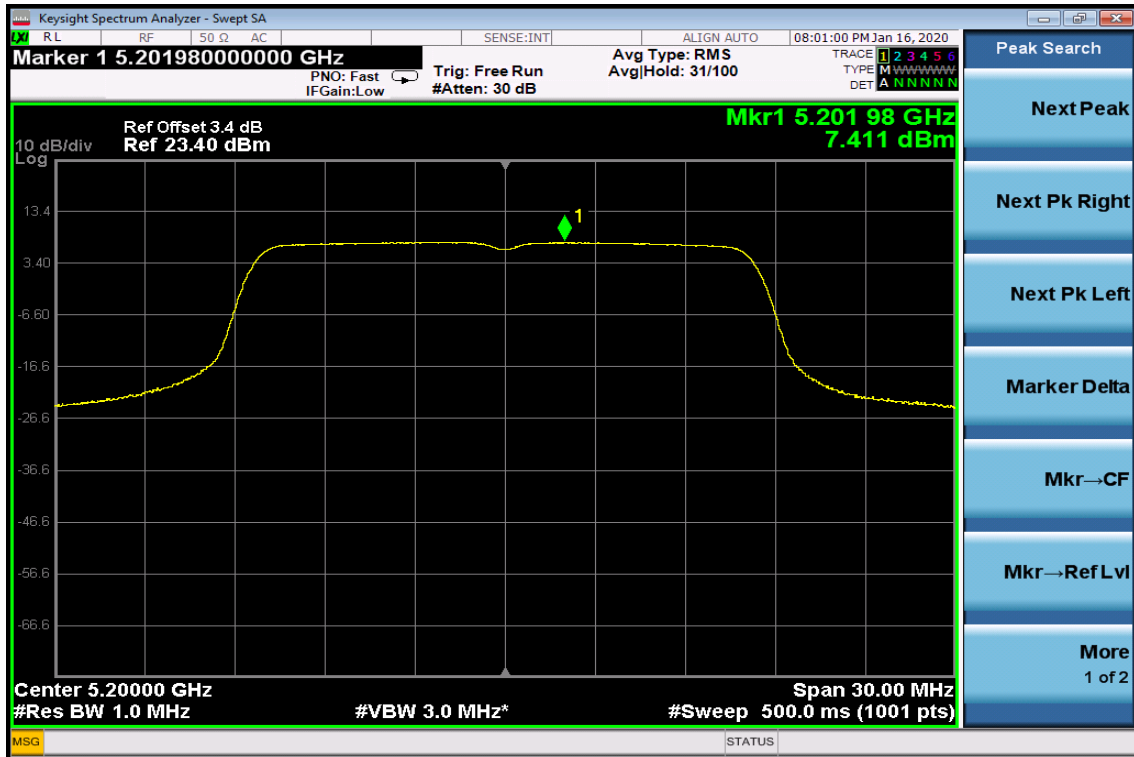

Power Spectral Density Data Plot (CH High)

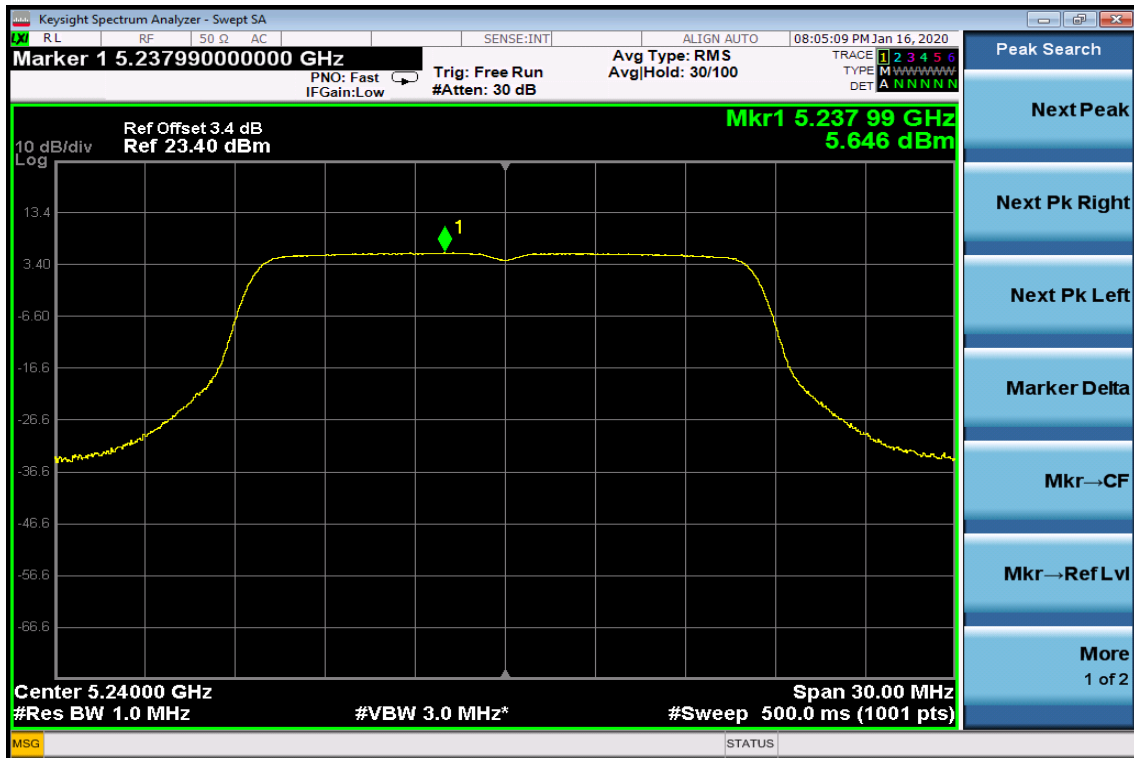

802.11n HT20

Power Spectral Density Test Plot (CH-Low)

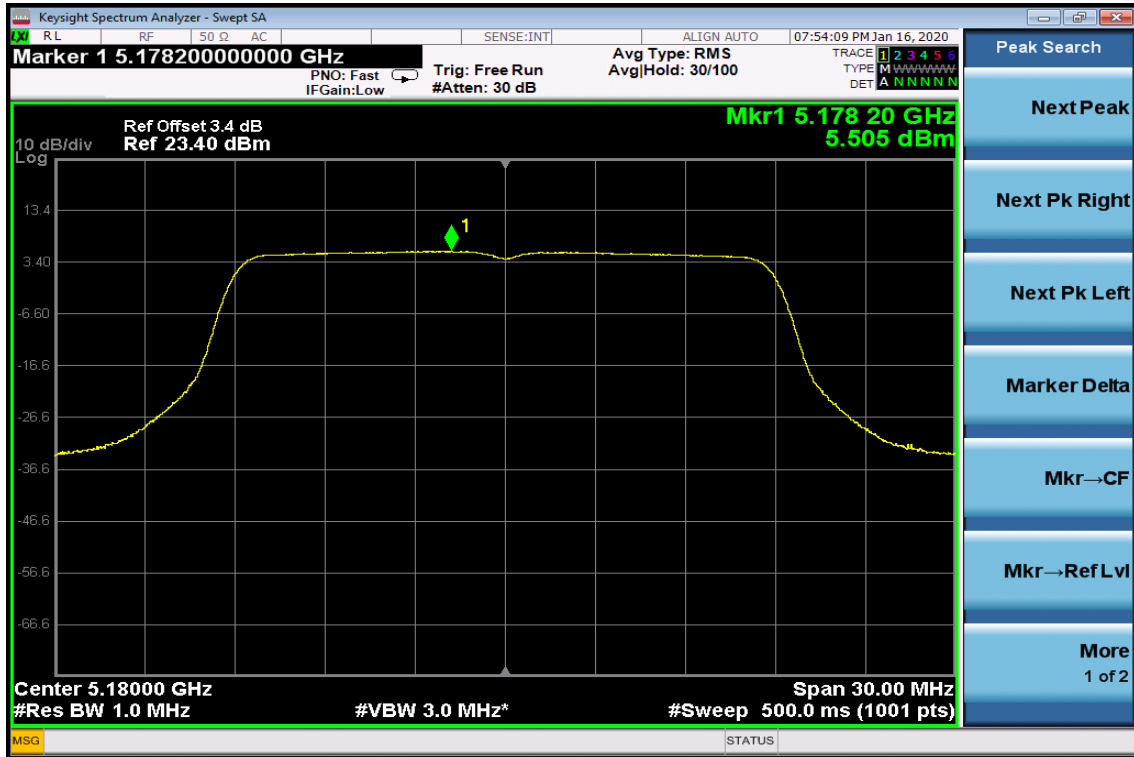

Power Spectral Density Test Plot (CH-Mid)

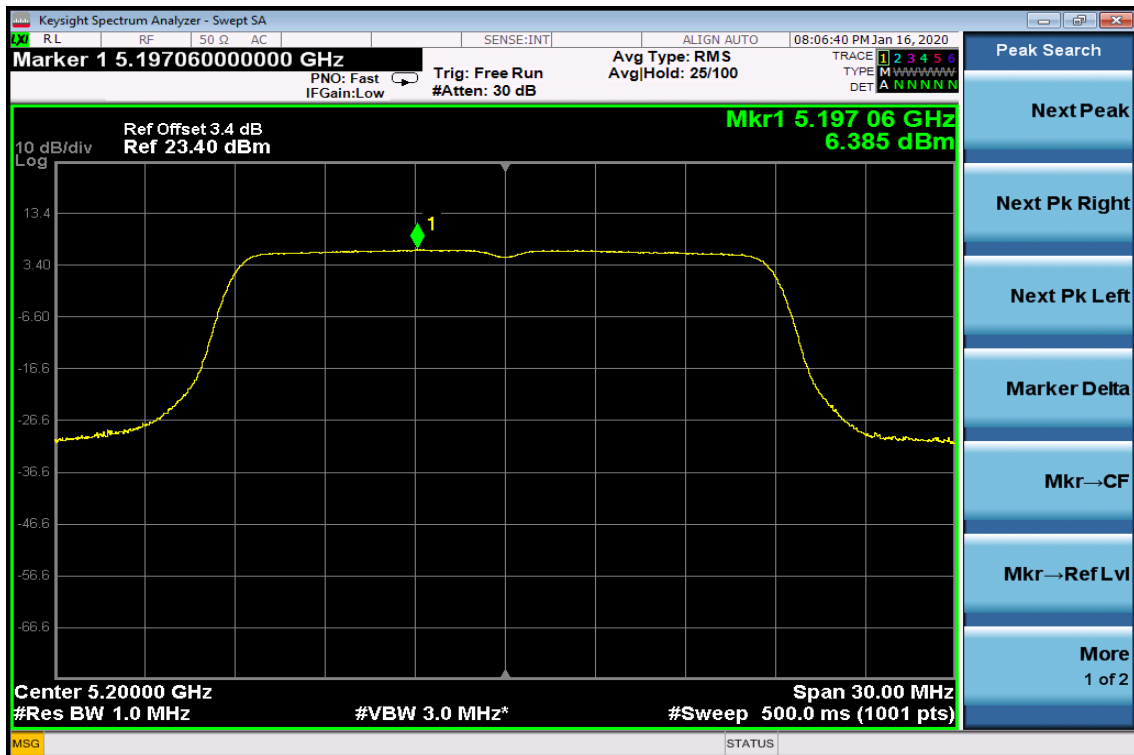

Power Spectral Density Test Plot (CH-High)

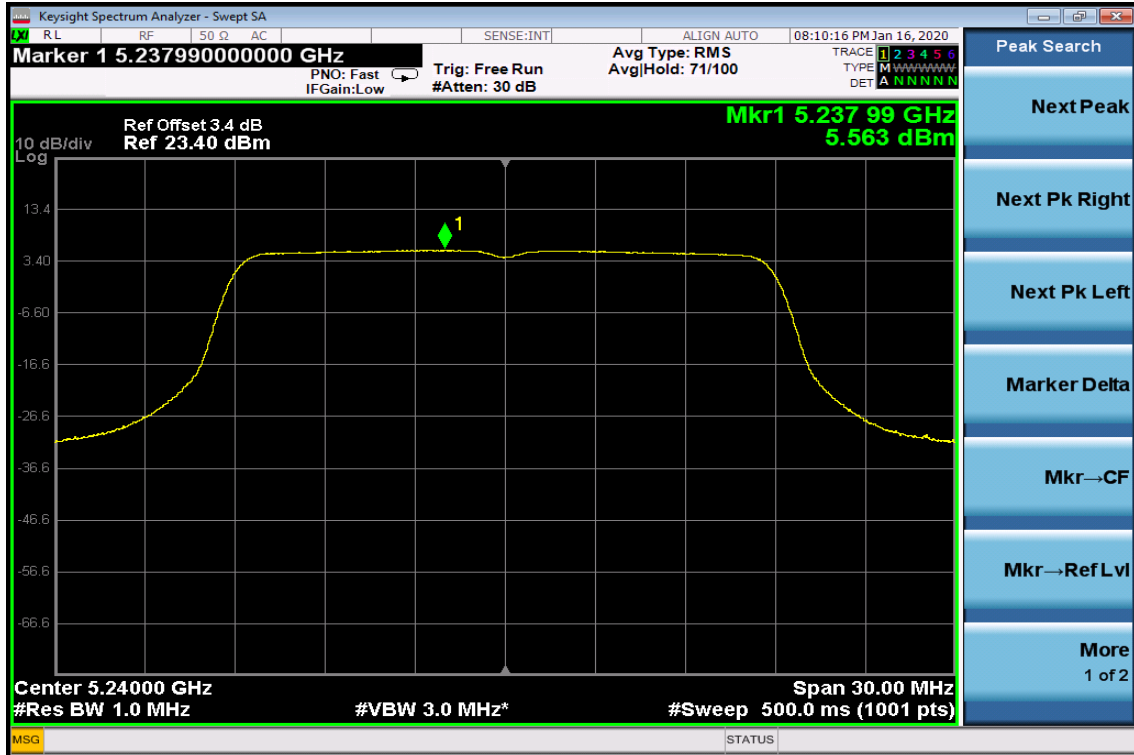

802.11n HT40

Power Spectral Density Test Plot (CH-Low)



Power Spectral Density Test Plot (CH-High)

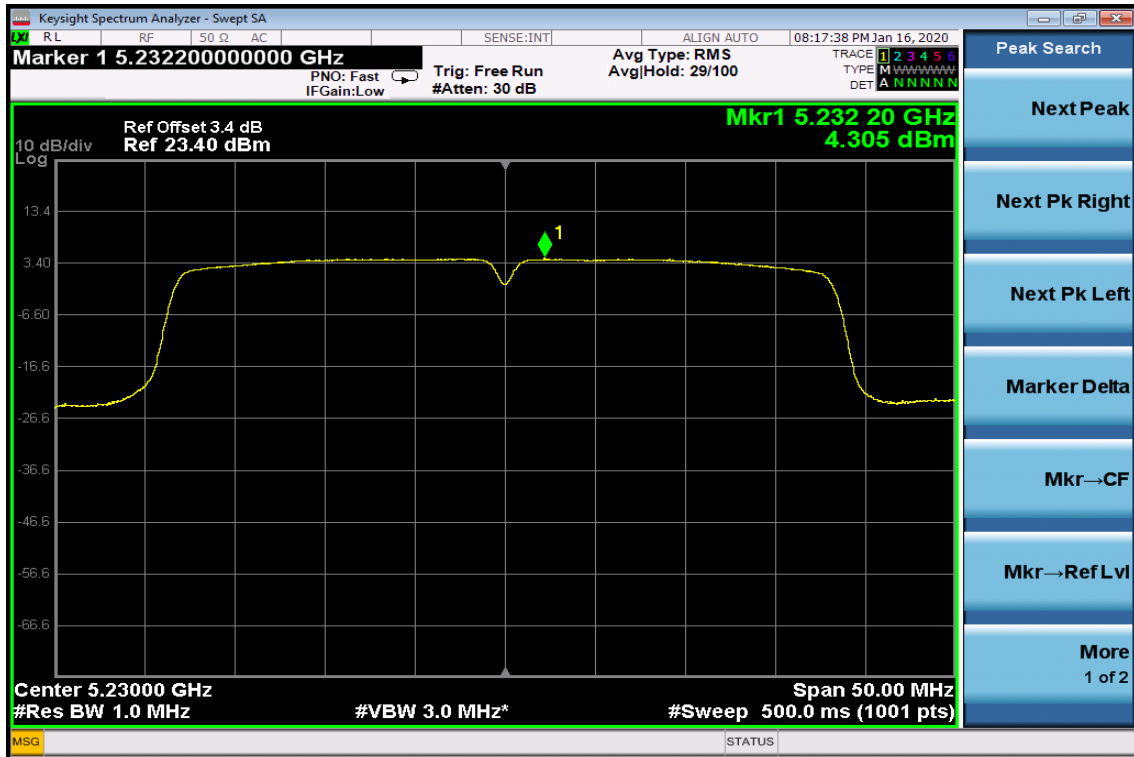

802.11ac VHT20

Power Spectral Density Test Plot (CH-Low)

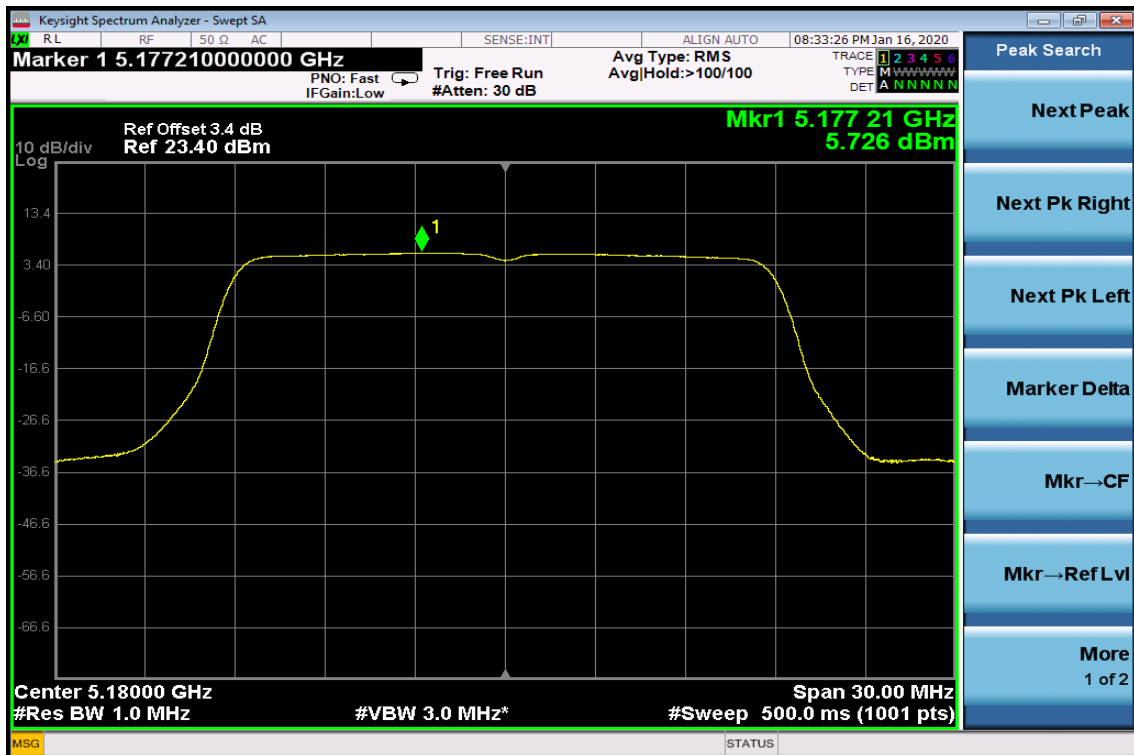

Power Spectral Density Test Plot (CH-Mid)

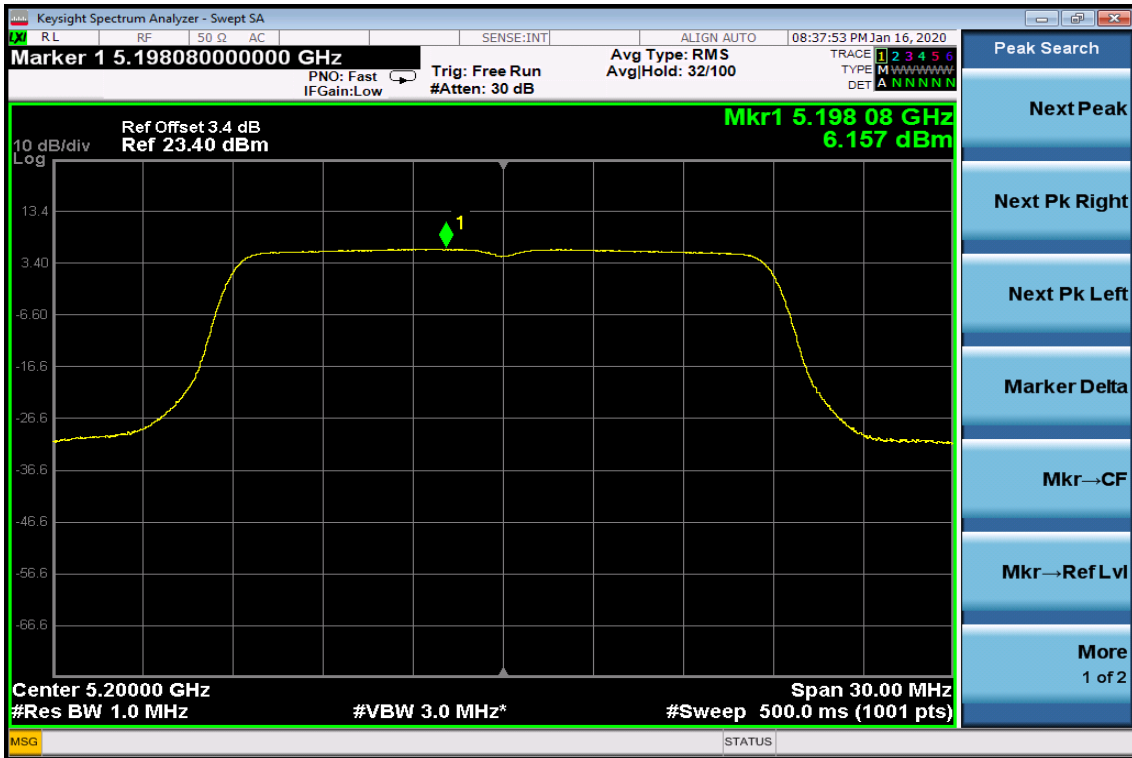

Power Spectral Density Test Plot (CH-High)

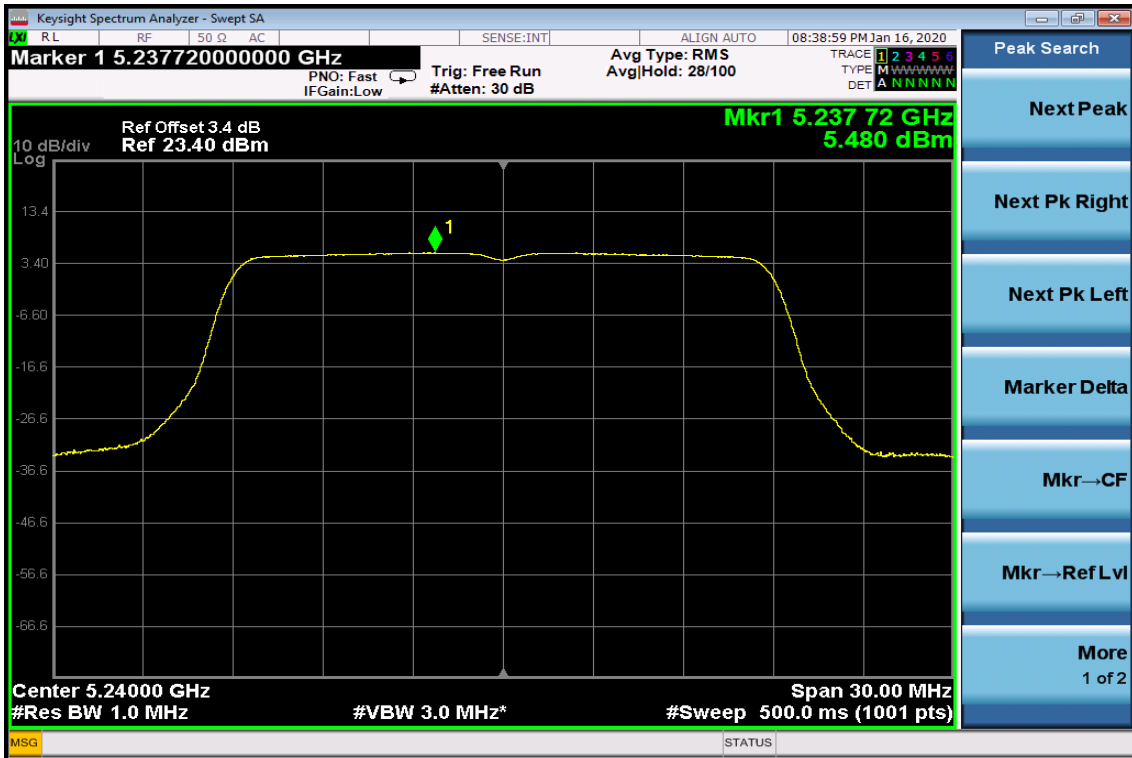

802.11ac VHT40

Power Spectral Density Test Plot (CH-Low)



Power Spectral Density Test Plot (CH-High)

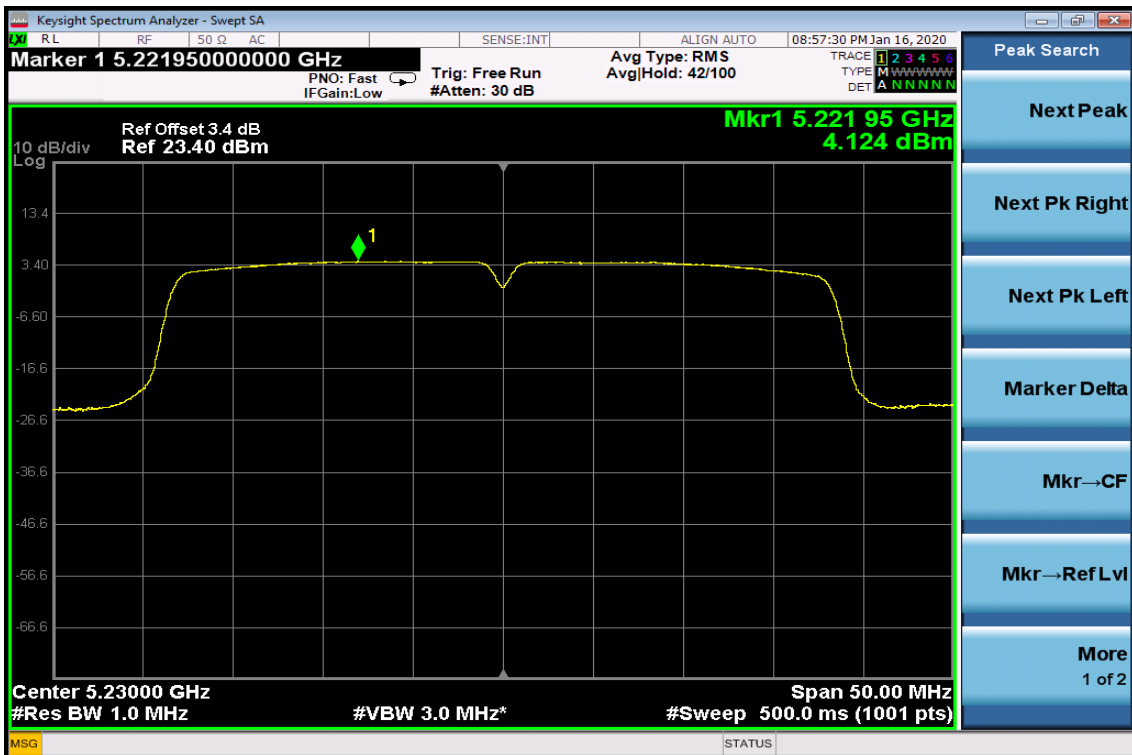

802.11ac VHT80 Power Spectral Density Test Plot (CH-Low)

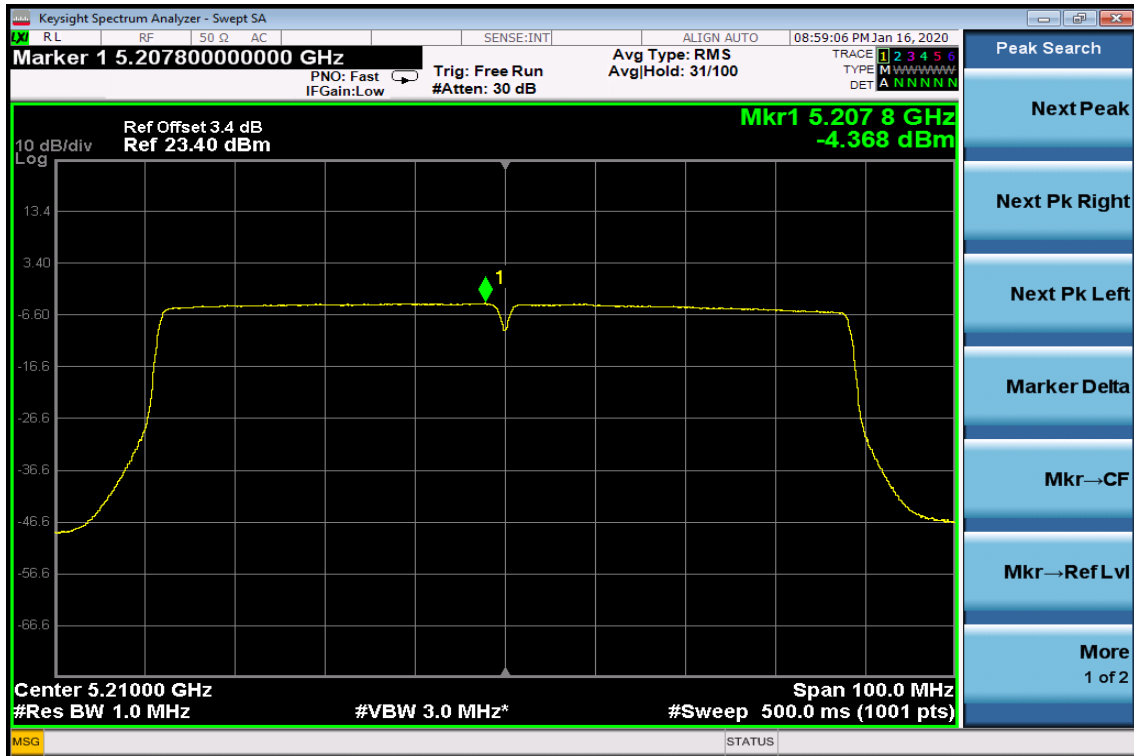

Band UNII-3

802.11a

Power Spectral Density Data Plot (CH Low)



Power Spectral Density Data Plot (CH Mid)

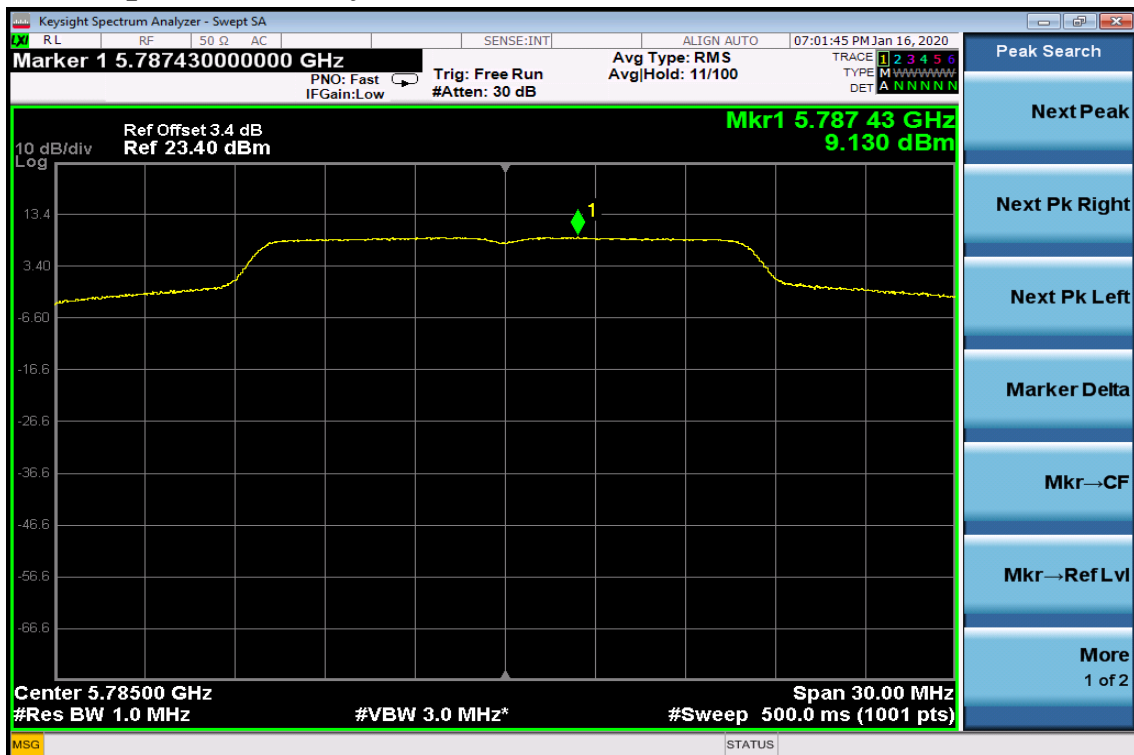

Power Spectral Density Data Plot (CH High)

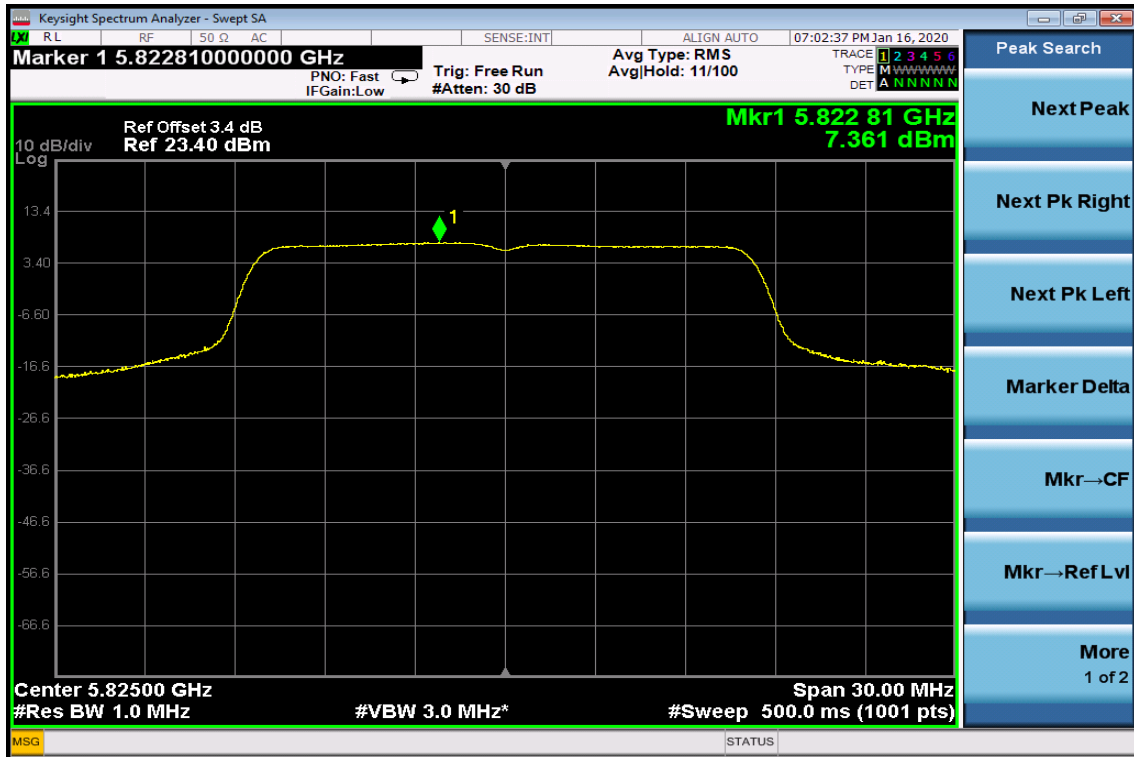

802.11n HT20

Power Spectral Density Test Plot (CH-Low)

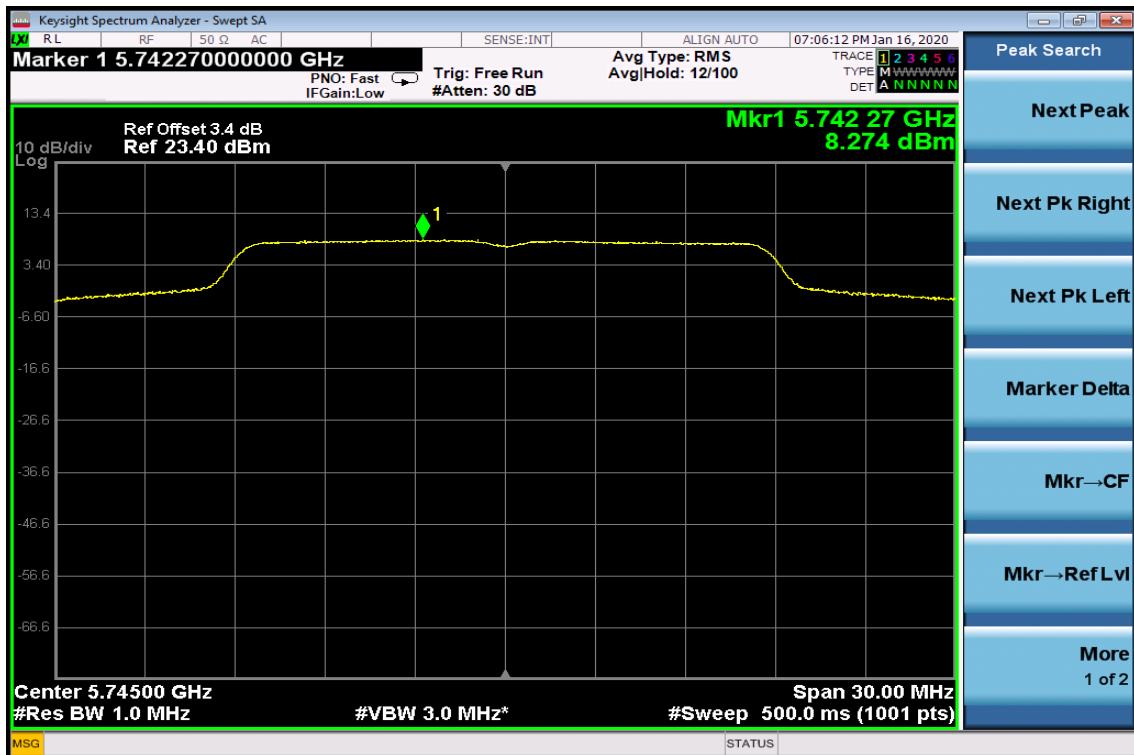

Power Spectral Density Test Plot (CH-Mid)

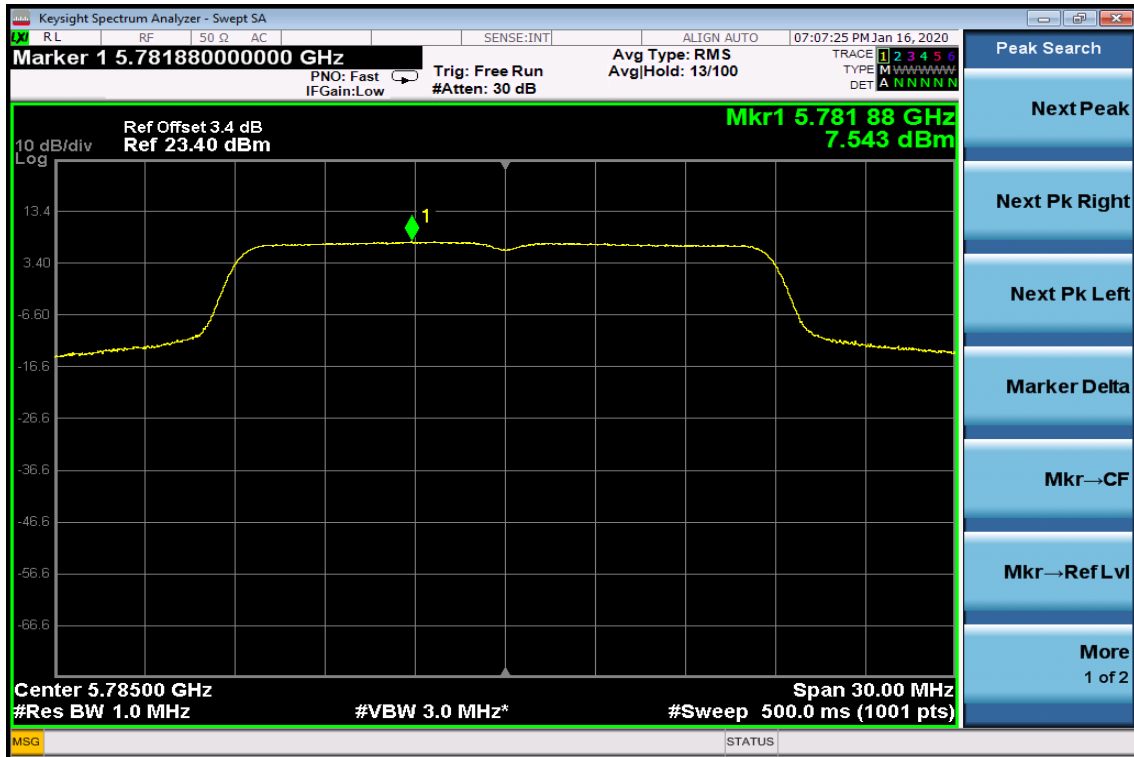

Power Spectral Density Test Plot (CH-High)

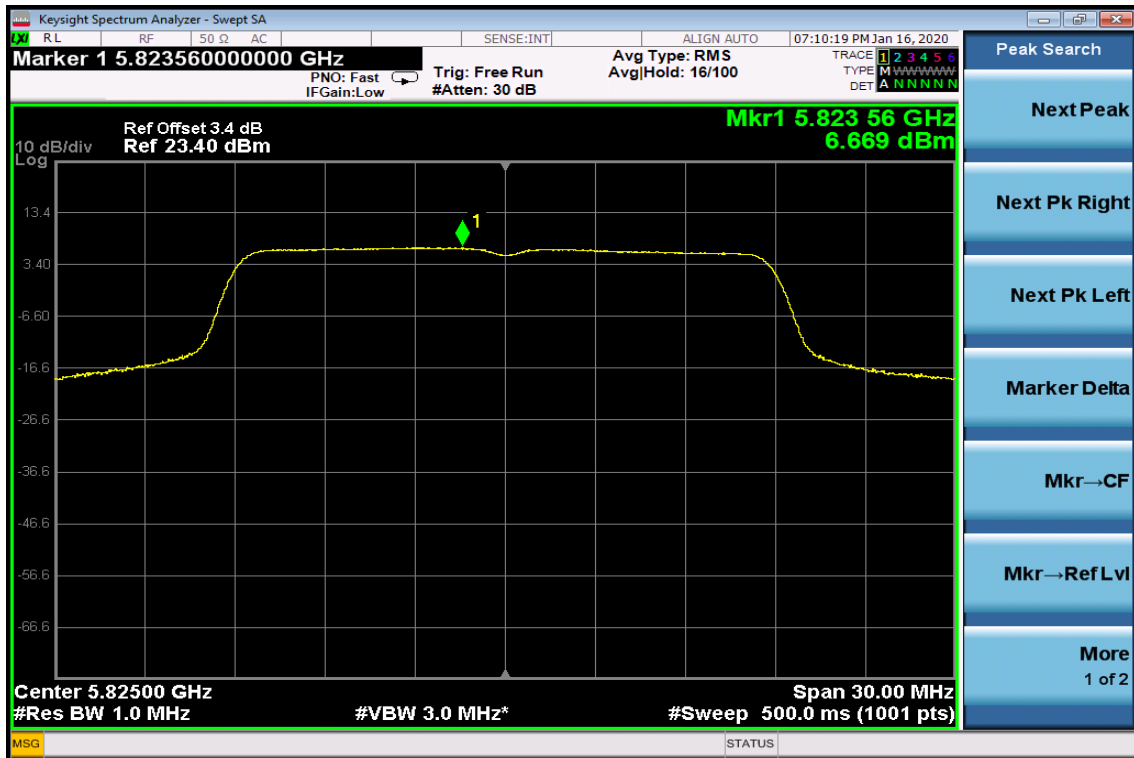

802.11n HT40

Power Spectral Density Test Plot (CH-Low)



Power Spectral Density Test Plot (CH-High)

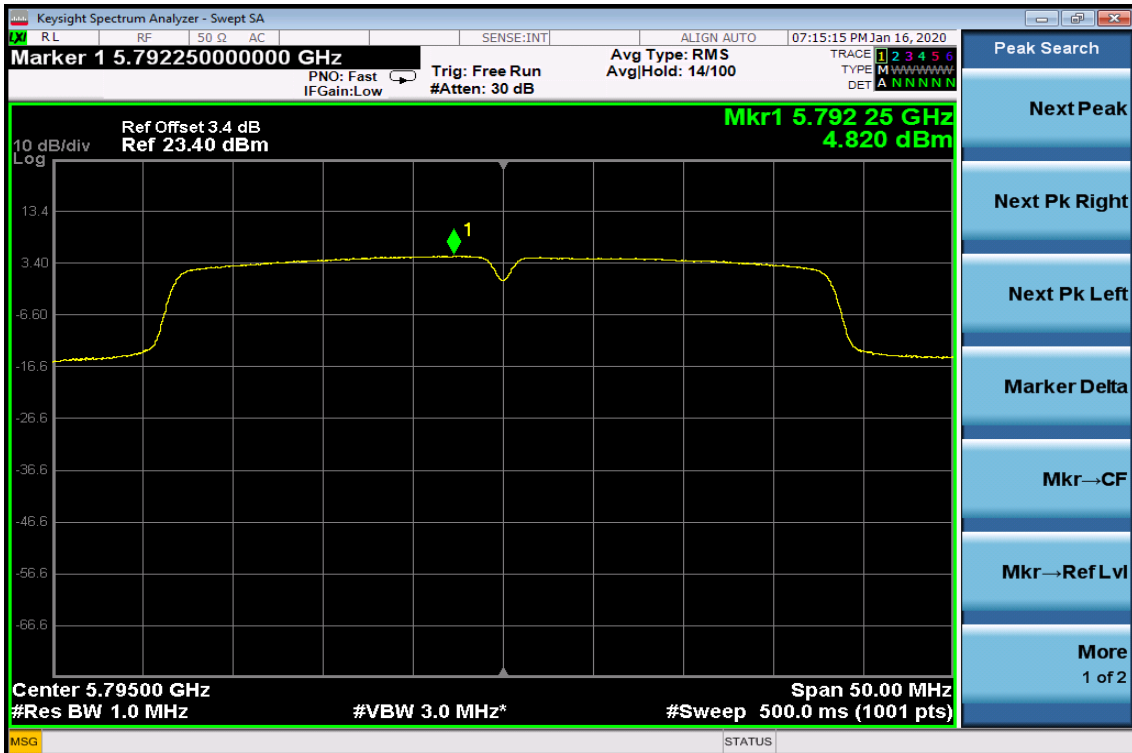

802.11ac VHT20 Power Spectral Density Test Plot (CH-Low)

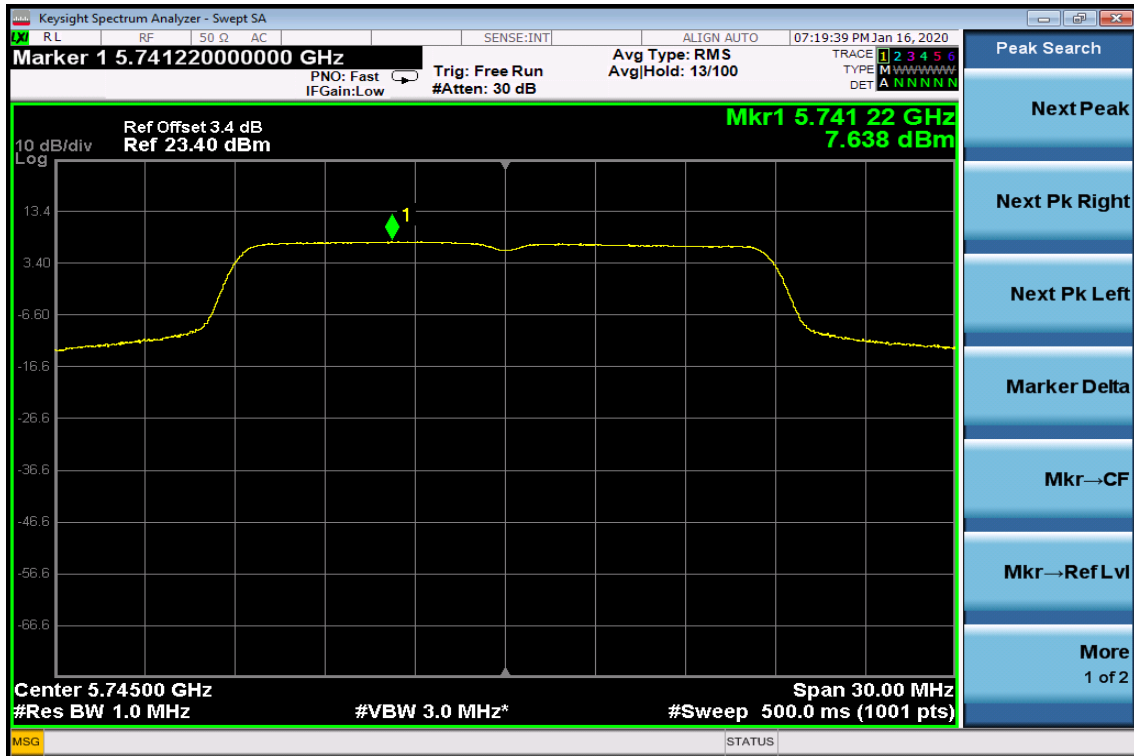

Power Spectral Density Test Plot (CH-Mid)

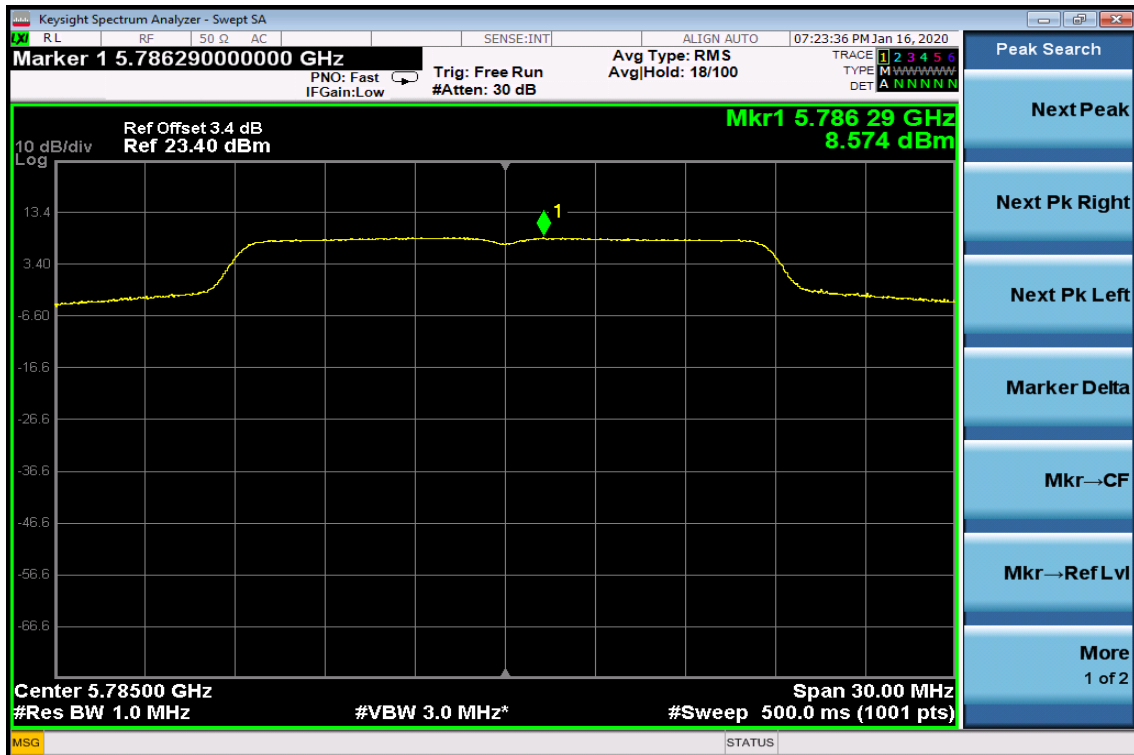

Power Spectral Density Test Plot (CH-High)

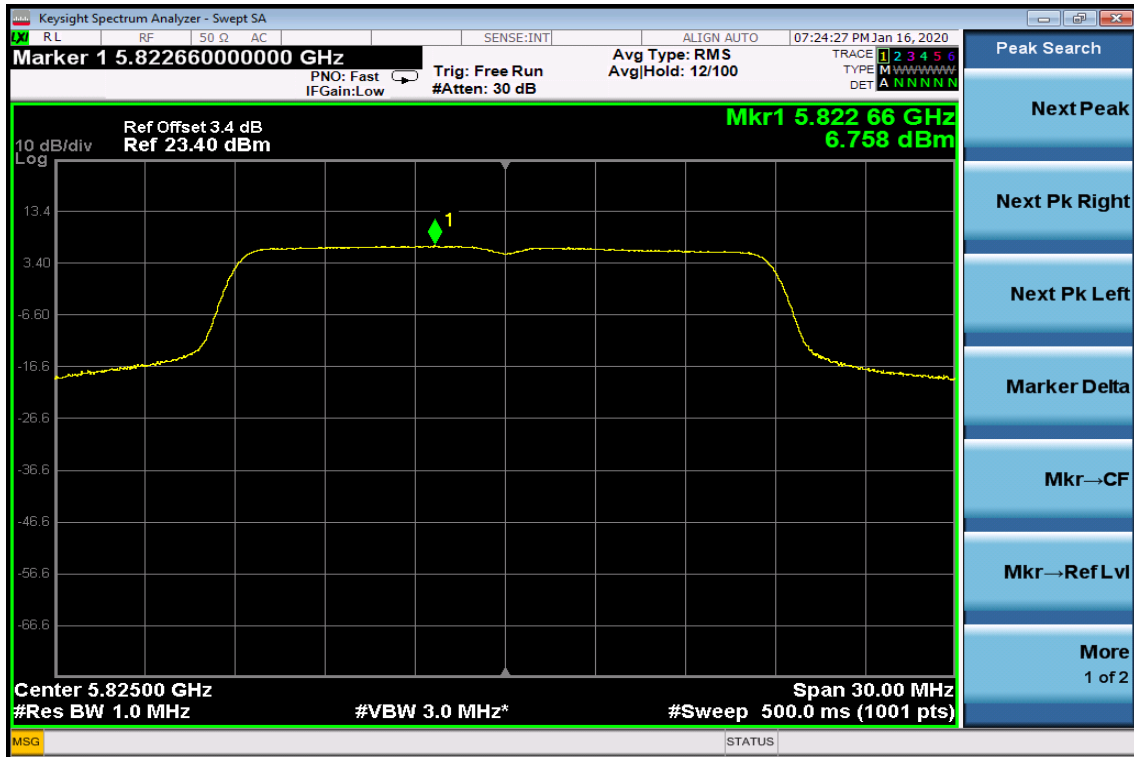

802.11ac VHT40

Power Spectral Density Test Plot (CH-Low)

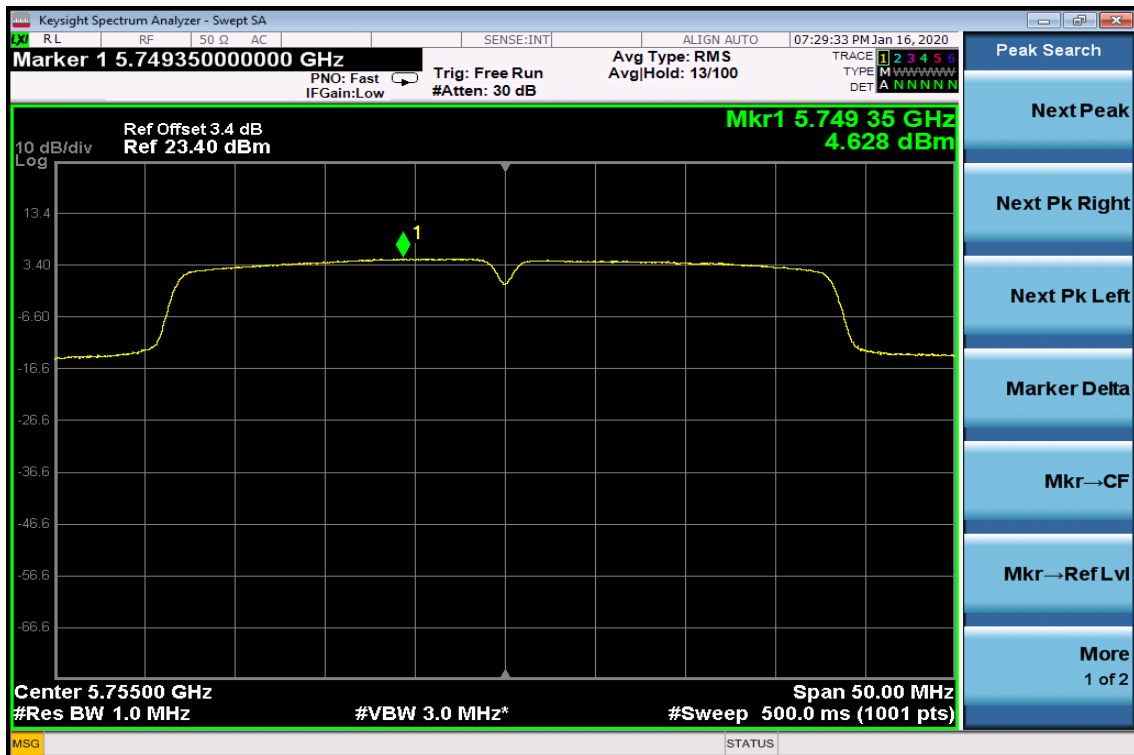

Power Spectral Density Test Plot (CH-High)

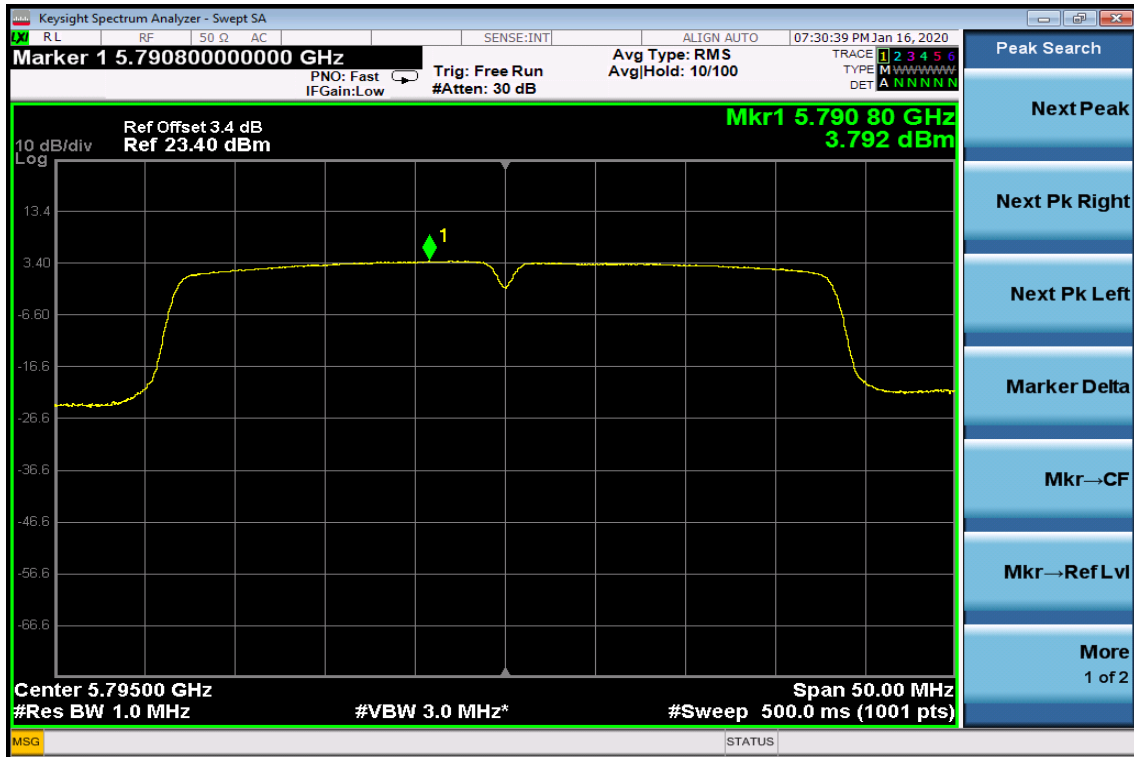

802.11ac VHT80

Power Spectral Density Test Plot

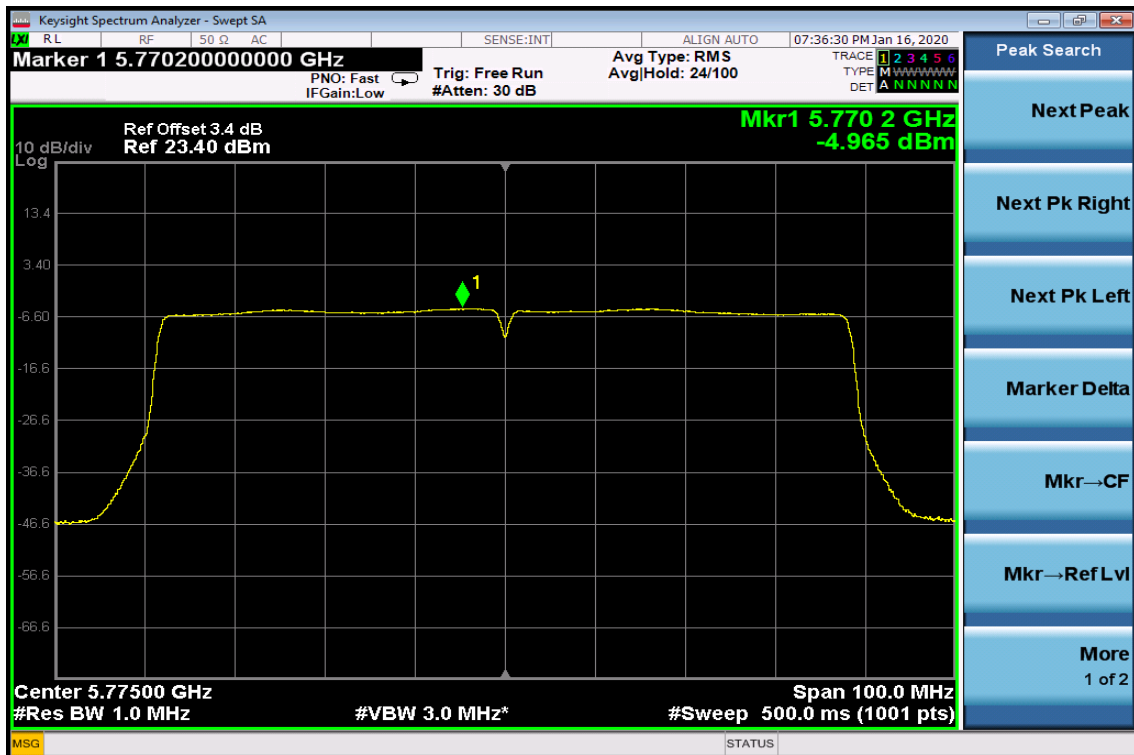

7. 26dB /99% Emission Bandwidth Measurement

7.1. Standard Applicable

According to §15.407(a) for band 1,2,3. No Limit required.

7.2. Measurement Procedure

1. Place the EUT on the table and set it in transmitting mode.
2. Remove the antenna from the EUT and then connect a low loss RF cable from the antenna port to the spectrum analyzer.
3. Set the spectrum analyzer as RBW=300kHz, VBW =1MHz, Span= 50MHz, Sweep=auto
4. Mark the peak frequency and -26dB (upper and lower) frequency.
5. Repeat above procedures until all frequency measured were complete.

Refer to section D of KDB Document: KDB 789033 D02 General UNII Test Procedures New Rules v02r01

7.3. Measurement Equipment Used:

Refer to section 6.3 for details.

7.4. Test Set-up:

Refer to section 6.4 for details.

7.5. Measurement Result

802.11a

Band	Frequency (MHz)	26dB Bandwidth (MHz)	99% OBW (MHz)	Limit
UNII-1	5180	20.11	16.47	NA
	5200	19.98	16.46	NA
	5240	20.71	16.51	NA

802.11n HT20

Band	Frequency (MHz)	26dB Bandwidth (MHz)	99% OBW (MHz)	Limit
UNII-1	5180	20.83	17.61	NA
	5200	20.36	17.63	NA
	5240	20.42	17.64	NA

802.11n HT40

Band	Frequency (MHz)	26dB Bandwidth (MHz)	99% OBW (MHz)	Limit
UNII-1	5190	39.86	35.91	NA
	5230	39.95	35.97	NA

802.11ac VHT20

Band	Frequency (MHz)	26dB Bandwidth (MHz)	99% OBW (MHz)	Limit
UNII-1	5180	20.76	17.60	NA
	5200	20.93	17.63	NA
	5240	20.70	17.65	NA

802.11ac VHT40

Band	Frequency (MHz)	26dB Bandwidth (MHz)	99% OBW (MHz)	Limit
UNII-1	5190	39.95	35.93	NA
	5230	39.93	35.95	NA

802.11a VHT80

Band	Frequency (MHz)	26dB Bandwidth (MHz)	99% OBW (MHz)	Limit
UNII-1	5210	83.31	75.70	NA

Band UNII-1

802.11a

26dB / 99% Band Width Test Data CH-Low

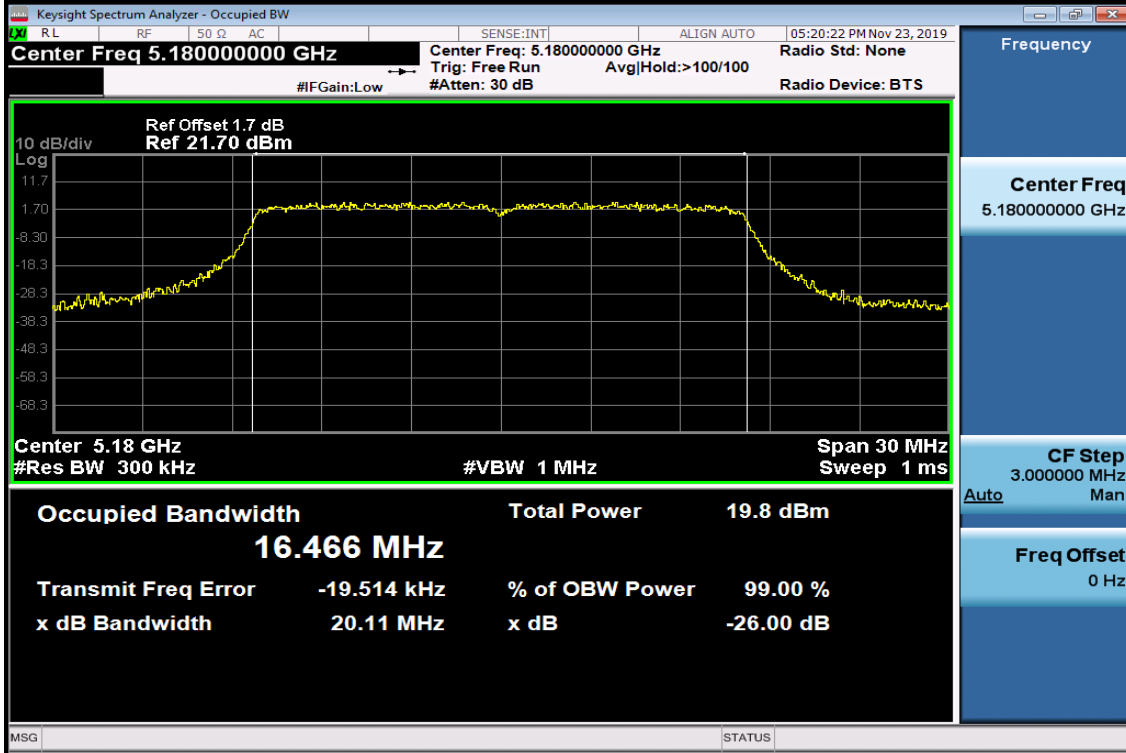

26dB / 99% Band Width Test Data CH-Mid

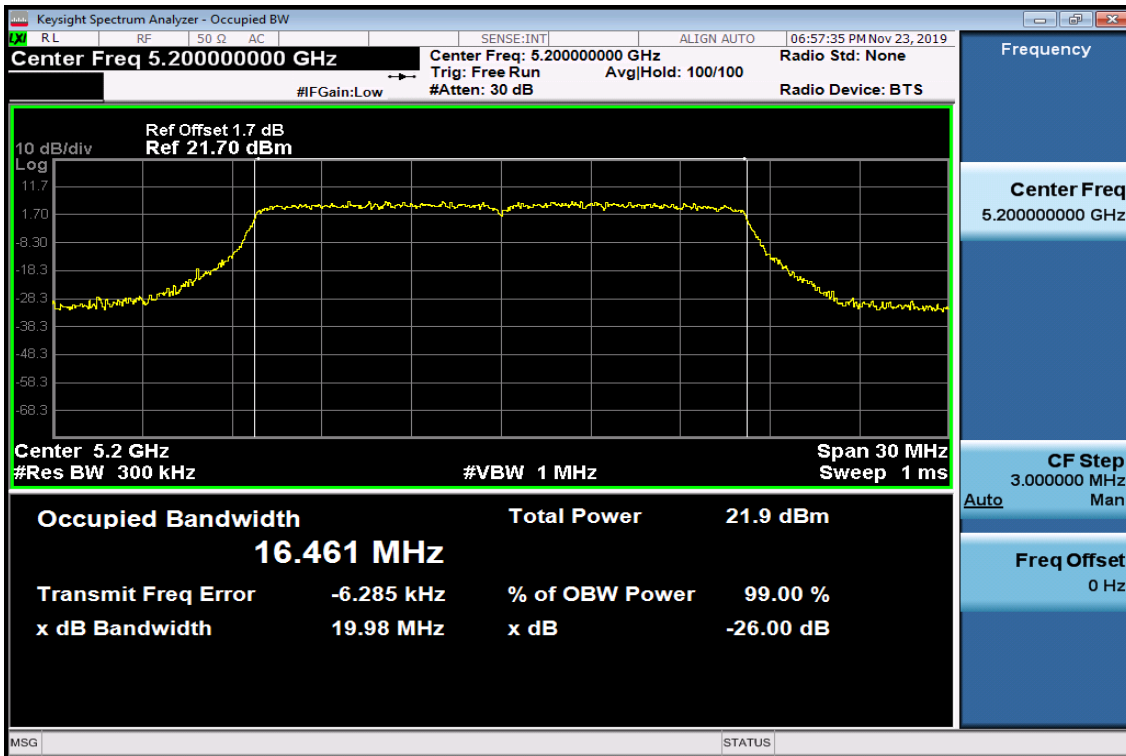

26dB / 99% Band Width Test Data CH-High

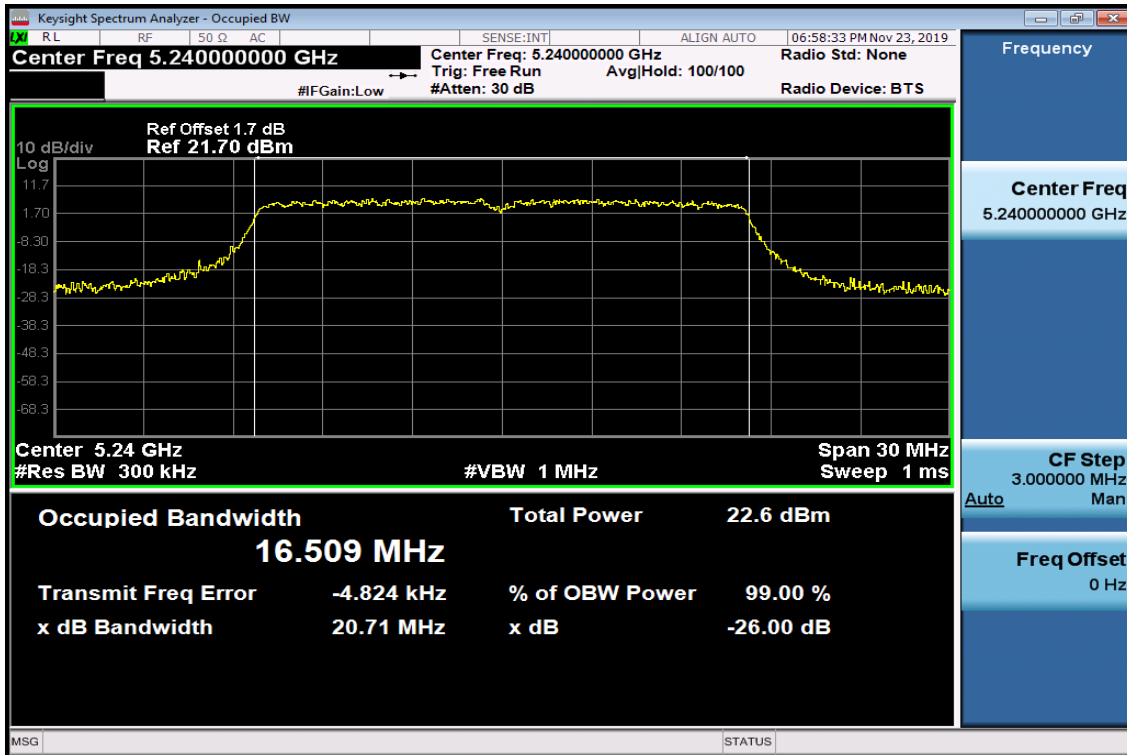

802.11n HT20

26dB / 99% Band Width Test Data CH-Low

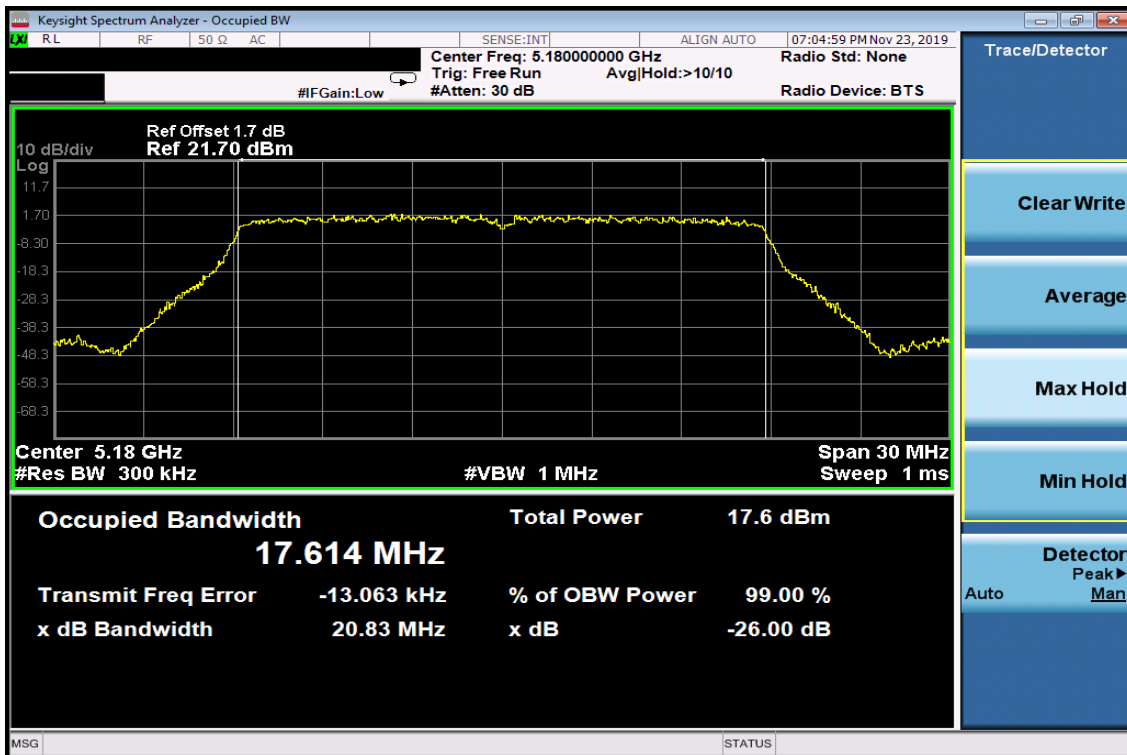

26dB / 99% Band Width Test Data CH-Mid

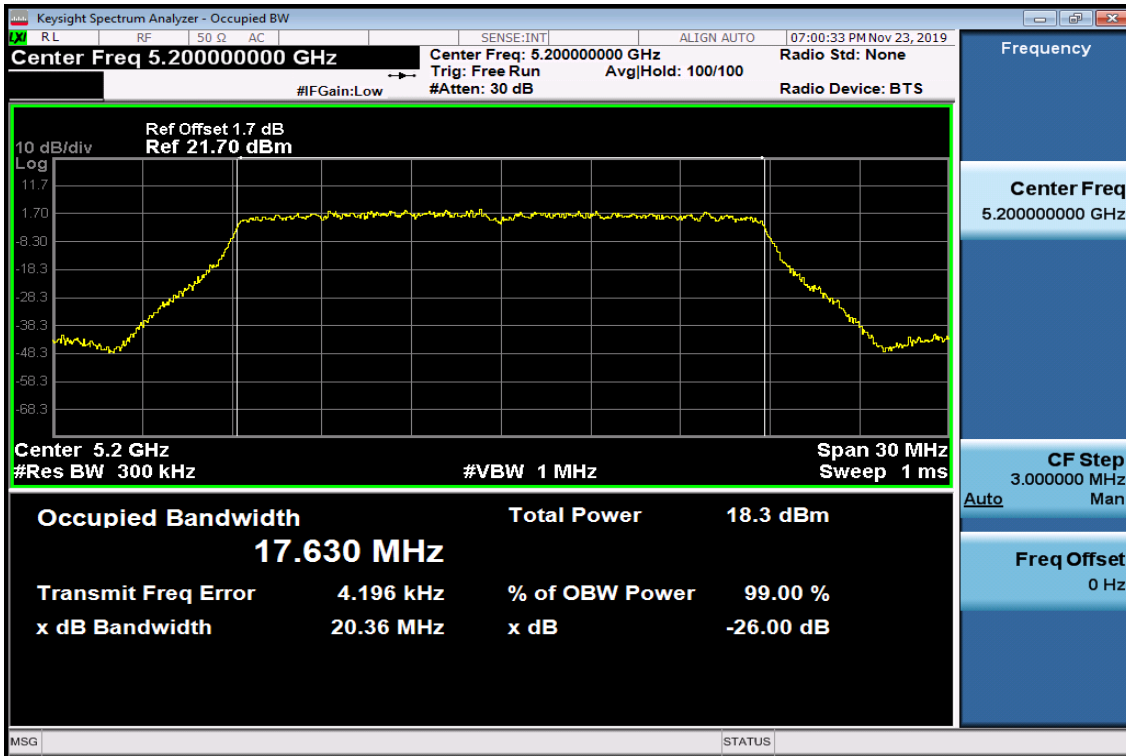

26dB / 99% Band Width Test Data CH-High

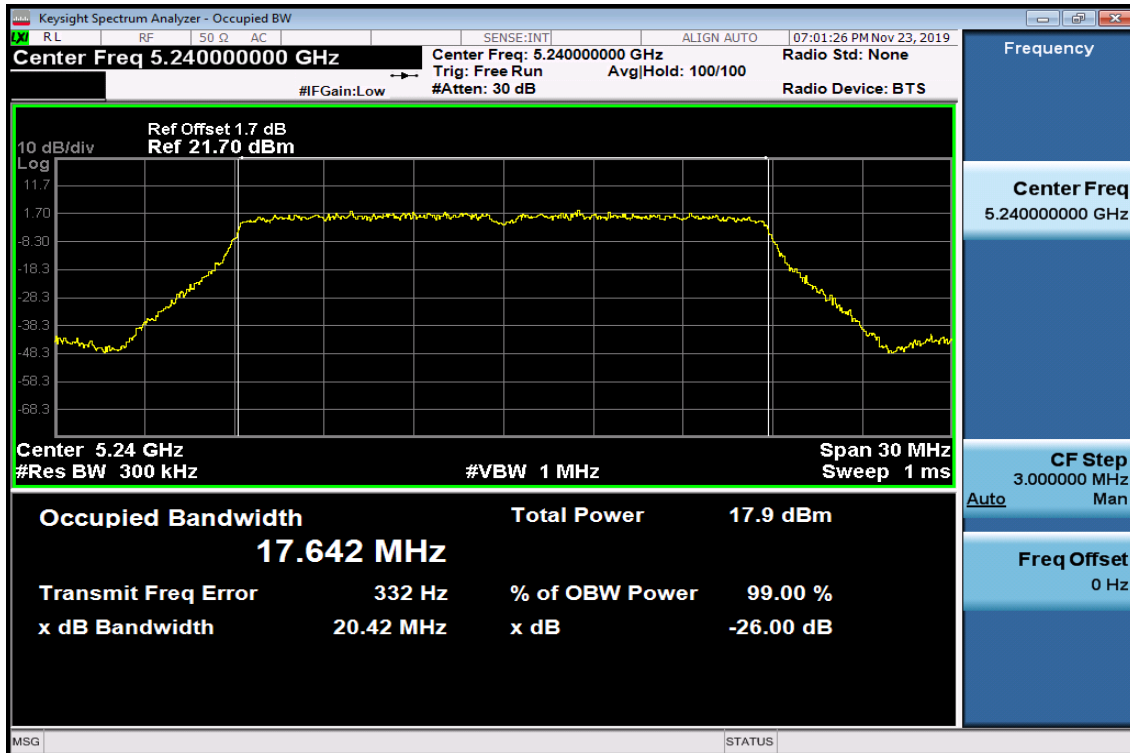

802.11n HT40

26dB / 99% Band Width Test Data CH-Low

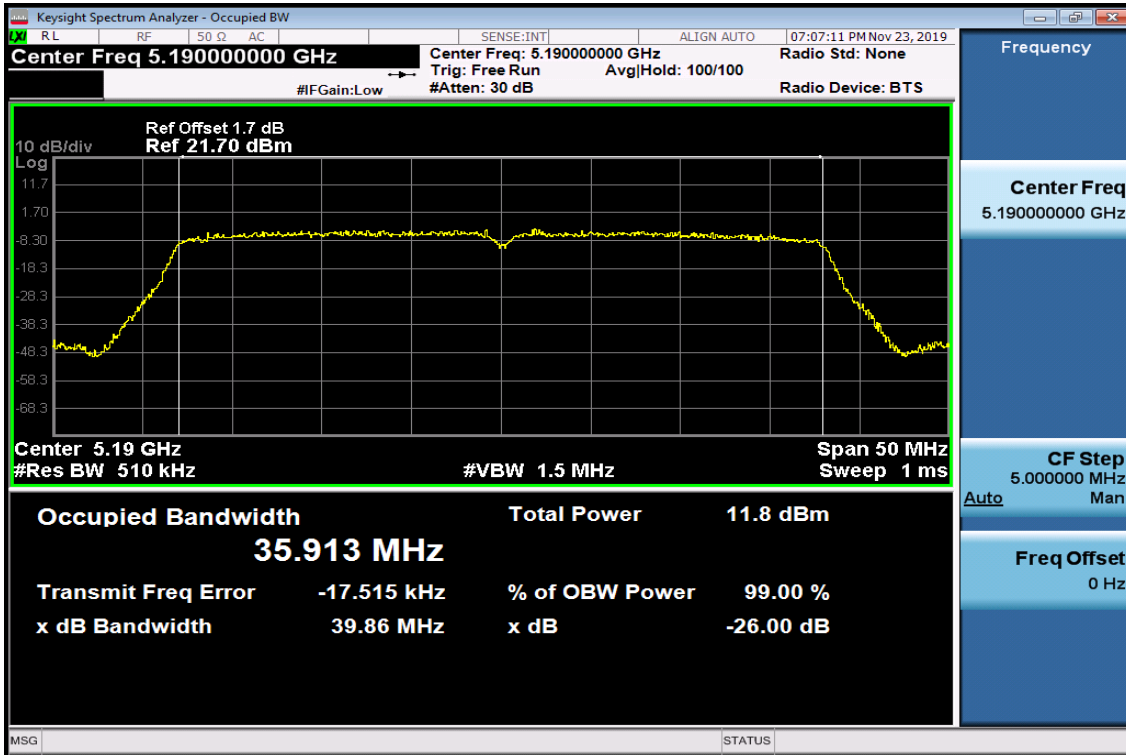

26dB / 99%Band Width Test Data CH-High

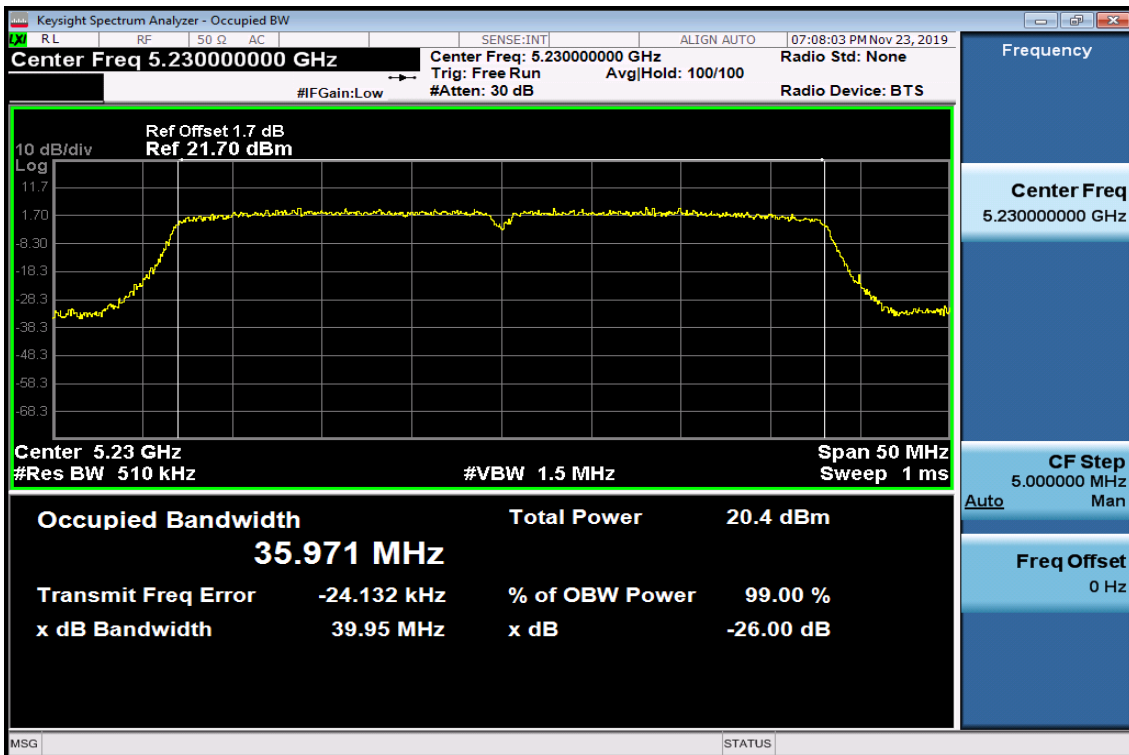

802.11ac VHT20

26dB / 99% Band Width Test Data CH-Low

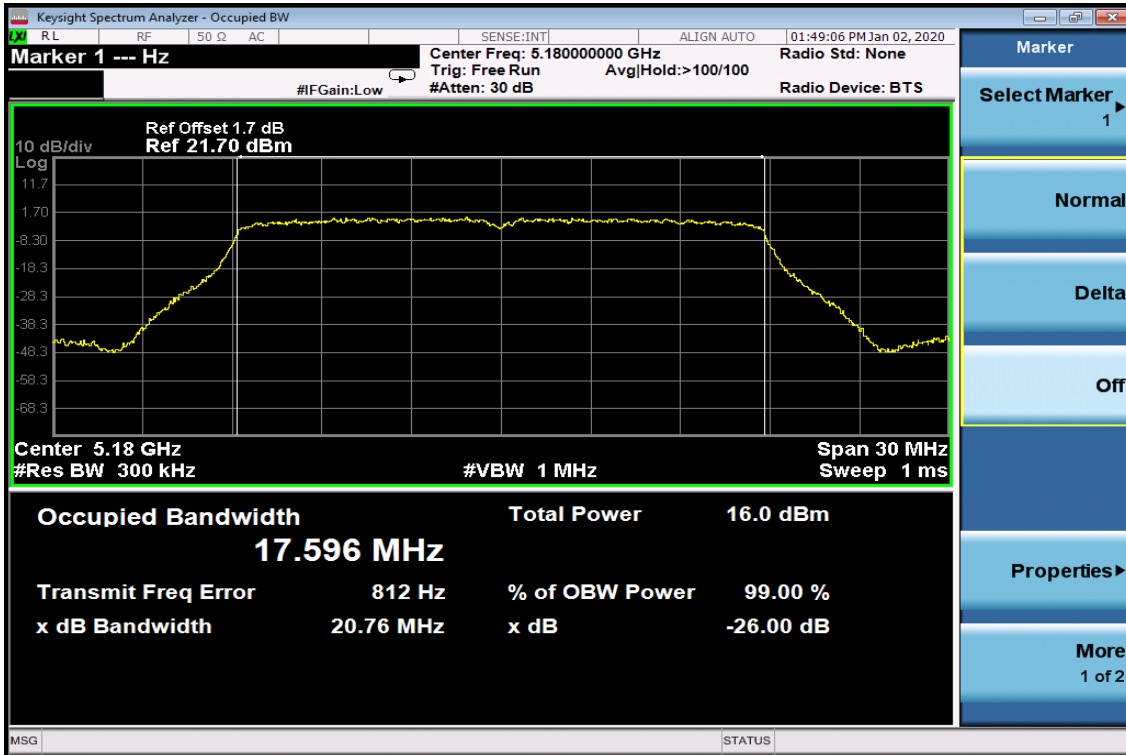

26dB / 99% Band Width Test Data CH-Mid

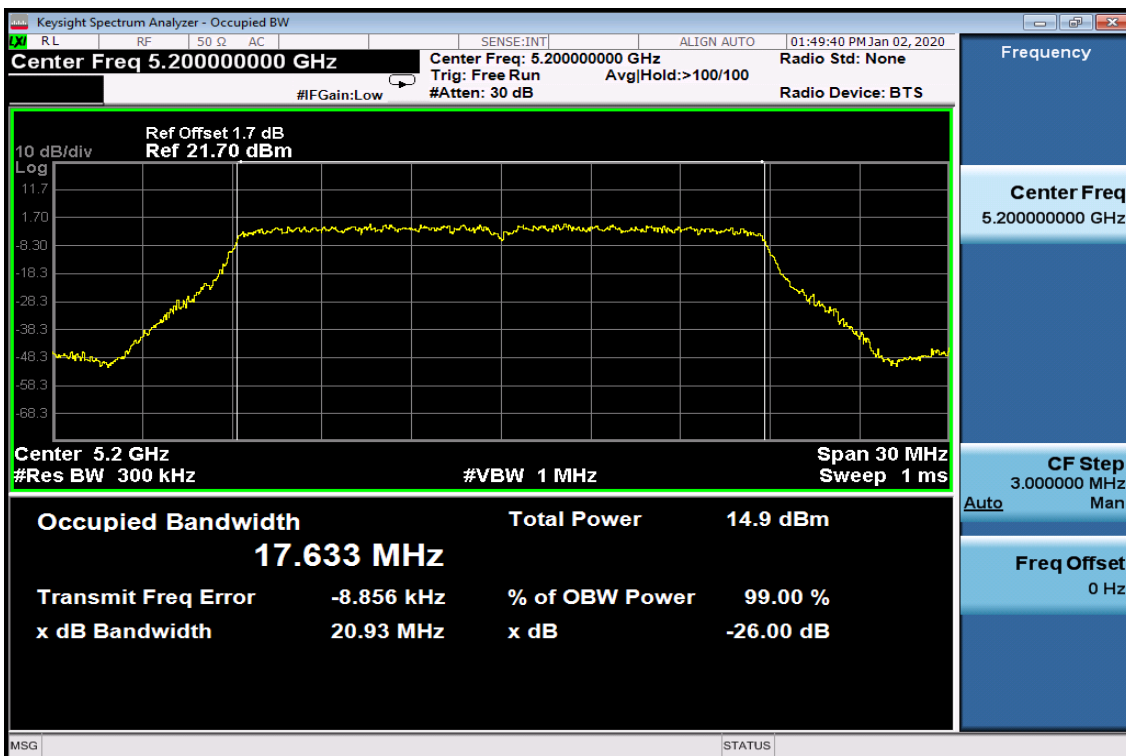

26dB / 99% Band Width Test Data CH-High

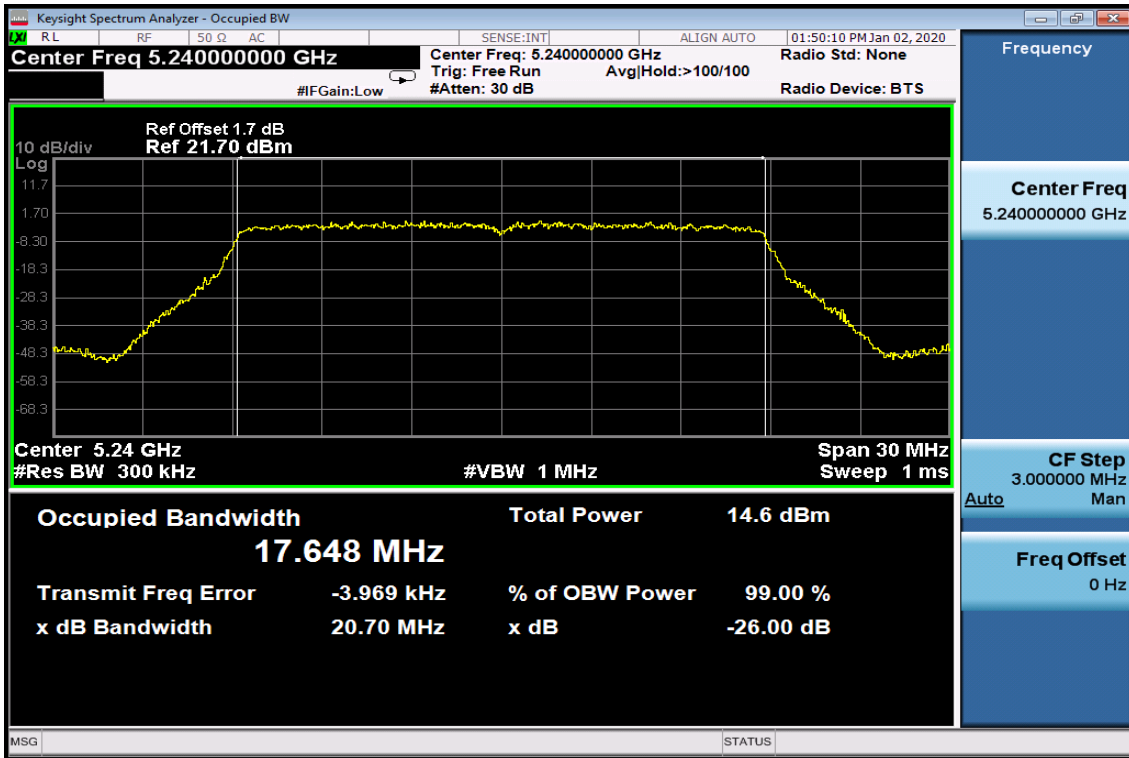

802.11ac VHT40

26dB / 99% Band Width Test Data CH-Low

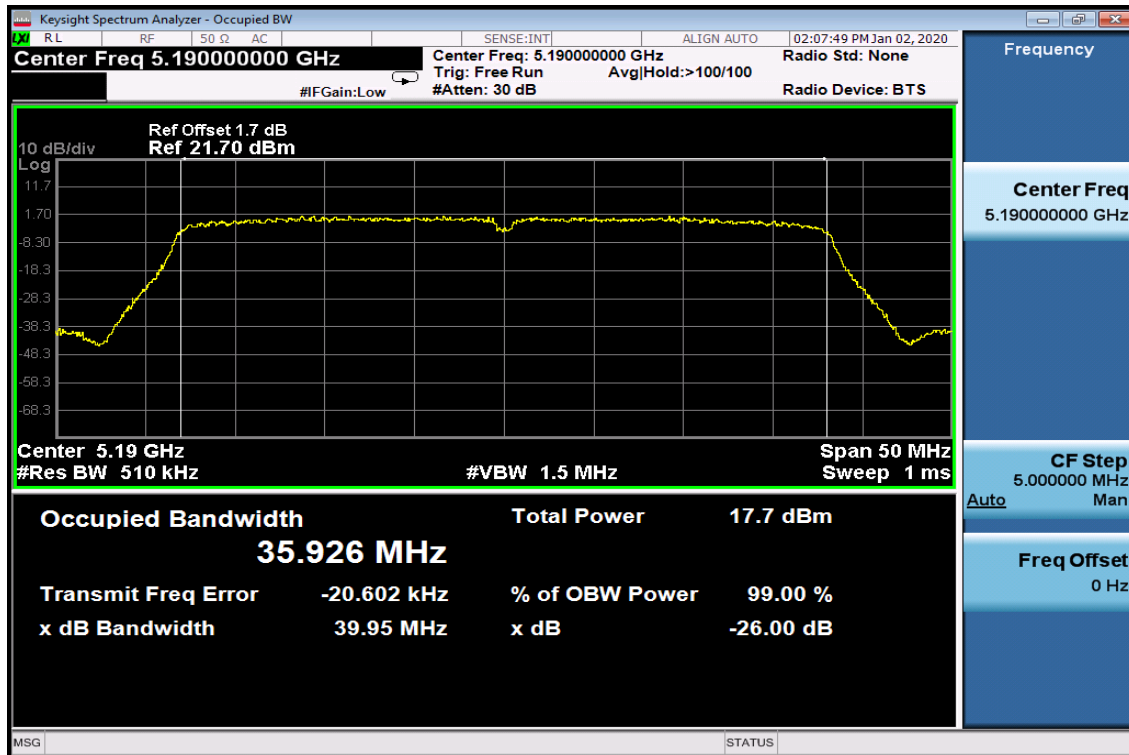

26dB / 99% Band Width Test Data CH-High

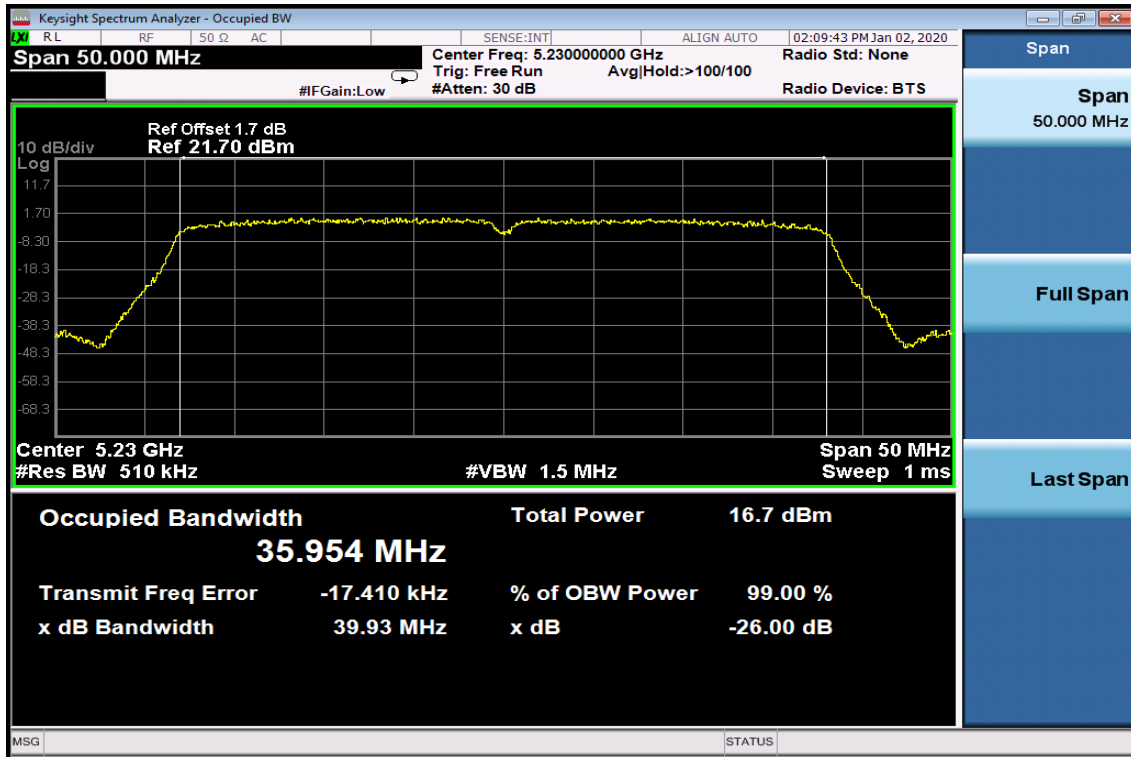

802.11ac VHT80

26dB / 99% Band Width Test Data CH-Low

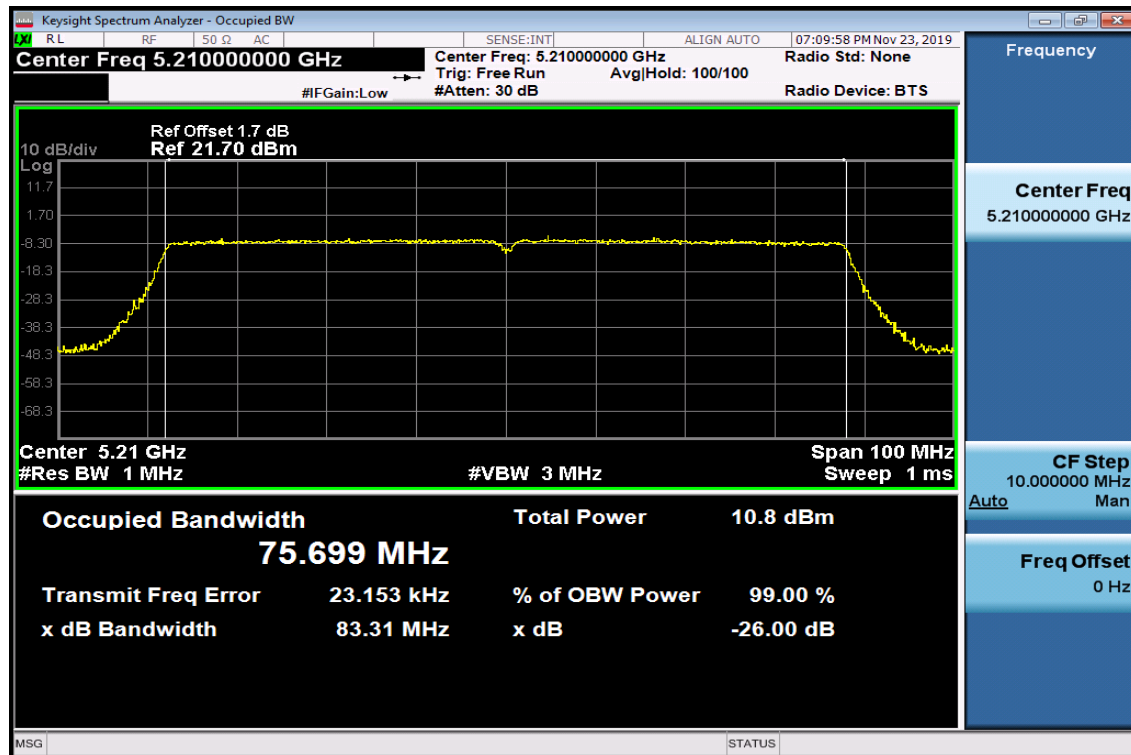

8. 6dB Emission Bandwidth Measurement

8.1. Standard Applicable

According to §15.407 (e) Within the 5.725-5.85 GHz band, the minimum 6 dB bandwidth of U-NII devices shall be at least 500 kHz.

8.2. Measurement Procedure

1. Place the EUT on the table and set it in transmitting mode.
2. Remove the antenna from the EUT and then connect a low loss RF cable from the antenna port to the spectrum analyzer.
3. Set the spectrum analyzer as RBW=100kHz, VBW =300MHz, Span= 50MHz, Sweep=auto
4. Mark the peak frequency and -6dB (upper and lower) frequency.
5. Repeat above procedures until all frequency measured were complete.

Refer to section D of KDB Document: KDB 789033 D02 General UNII Test Procedures New Rules v02r01

8.3. Measurement Equipment Used:

Refer to section 6.3 for details.

8.4. Test Set-up:

Refer to section 6.4 for details.

8.5. Measurement Result

802.11a

Band	Frequency (MHz)	6dB Bandwidth (MHz)	99% OBW (MHz)	6dB BW Limit (kHz)
UNII-3	5745	16.36	16.65	> 500
	5785	16.38	16.66	> 500
	5825	16.36	16.60	> 500

802.11n HT20

Band	Frequency (MHz)	6dB Bandwidth (MHz)	99% OBW (MHz)	6dB BW Limit (kHz)
UNII-3	5745	17.53	17.75	> 500
	5785	17.56	17.76	> 500
	5825	17.59	19.15	> 500

802.11n HT40

Band	Frequency (MHz)	6dB Bandwidth (MHz)	99% OBW (MHz)	6dB BW Limit (kHz)
UNII-3	5755	34.98	35.96	> 500
	5795	36.38	36.67	> 500

802.11ac VHT20

Band	Frequency (MHz)	6dB Bandwidth (MHz)	99% OBW (MHz)	6dB BW Limit (kHz)
UNII-3	5745	17.55	17.56	> 500
	5785	17.56	17.58	> 500
	5825	17.30	17.56	> 500

802.11ac VHT40

Band	Frequency (MHz)	6dB Bandwidth (MHz)	99% OBW (MHz)	6dB BW Limit (kHz)
UNII-3	5755	35.16	35.83	> 500
	5795	35.16	35.87	> 500

802.11a VHT80

Band	Frequency (MHz)	6dB Bandwidth (MHz)	99% OBW (MHz)	6dB BW Limit (kHz)
UNII-3	5775	76.07	75.55	> 500

Band UNII-3

802.11a

6dB Band Width Test Data CH-Low

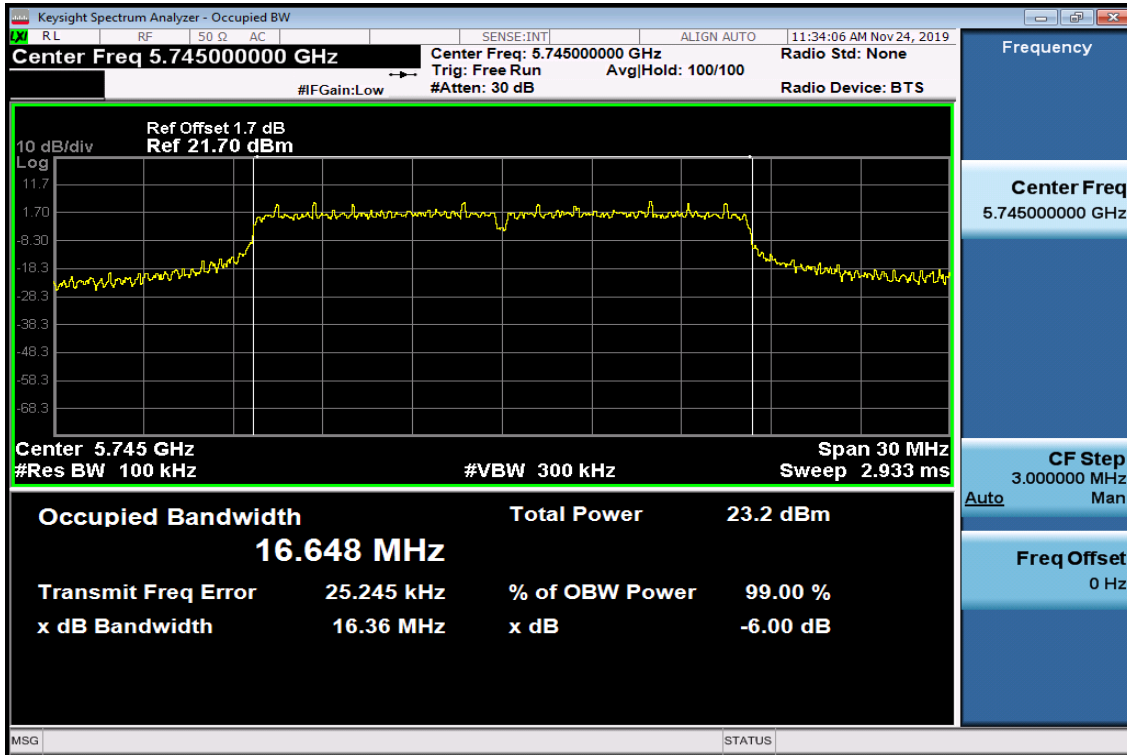

6dB Band Width Data CH-Mid

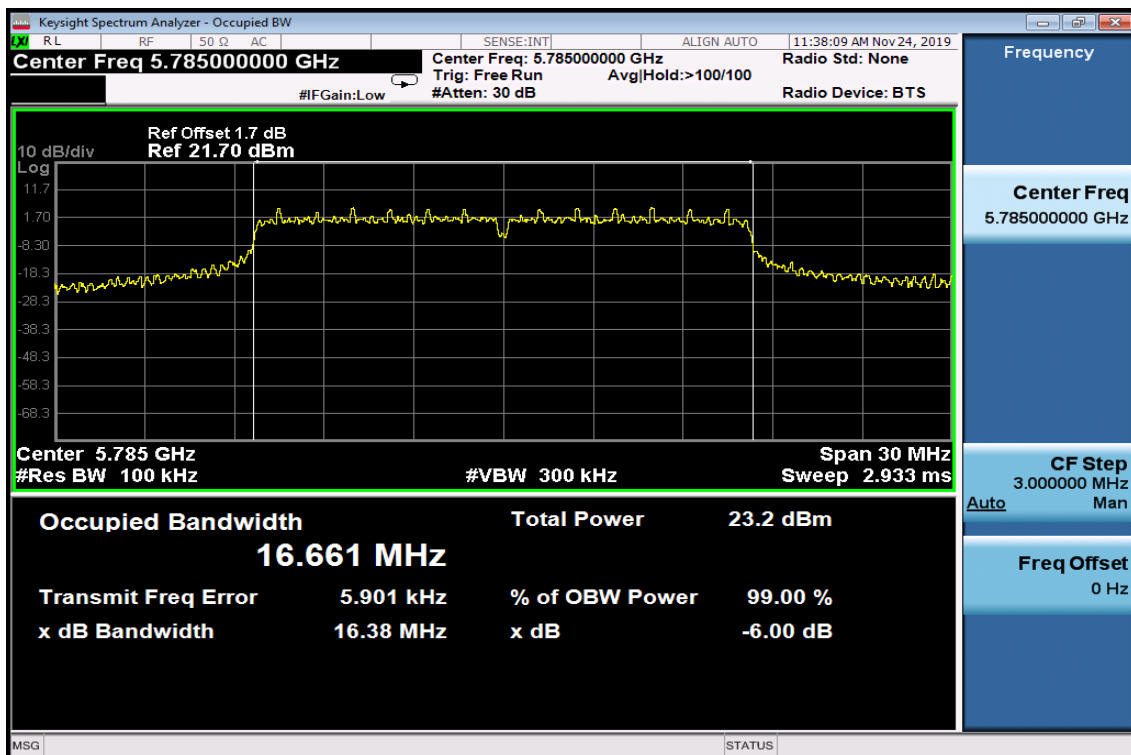

6dB Band Width Data CH-High

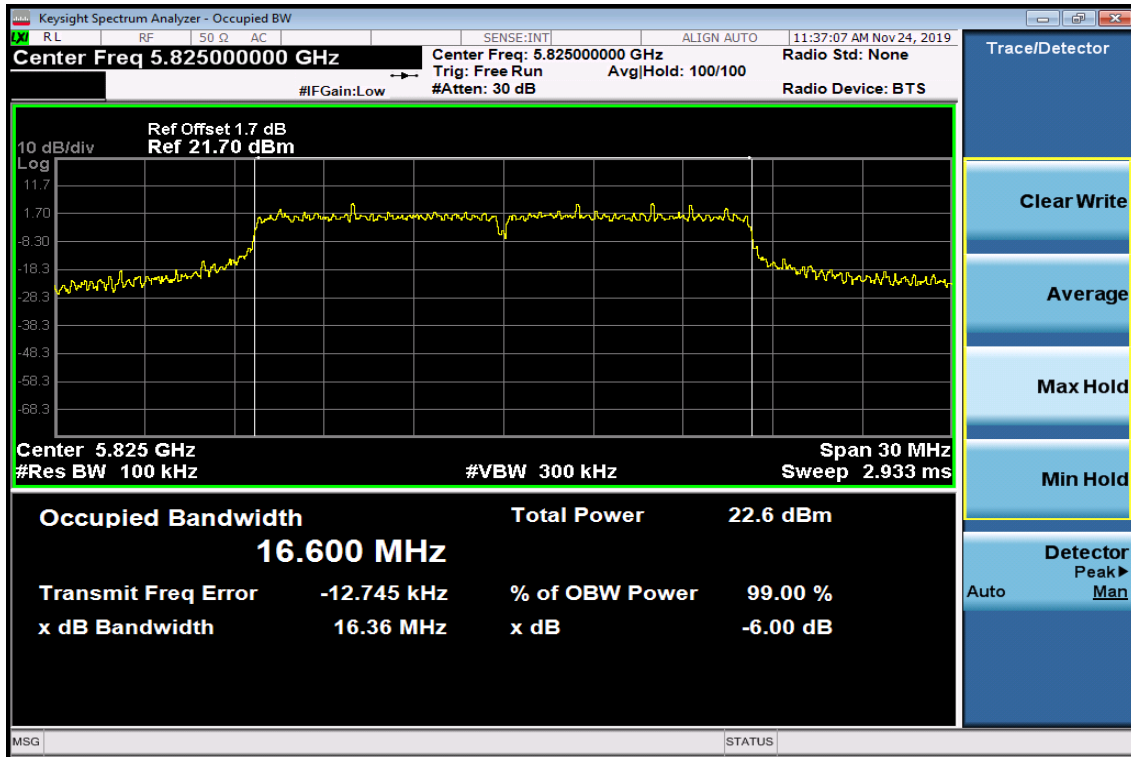

802.11n HT20

6dB Band Width Data CH-Low

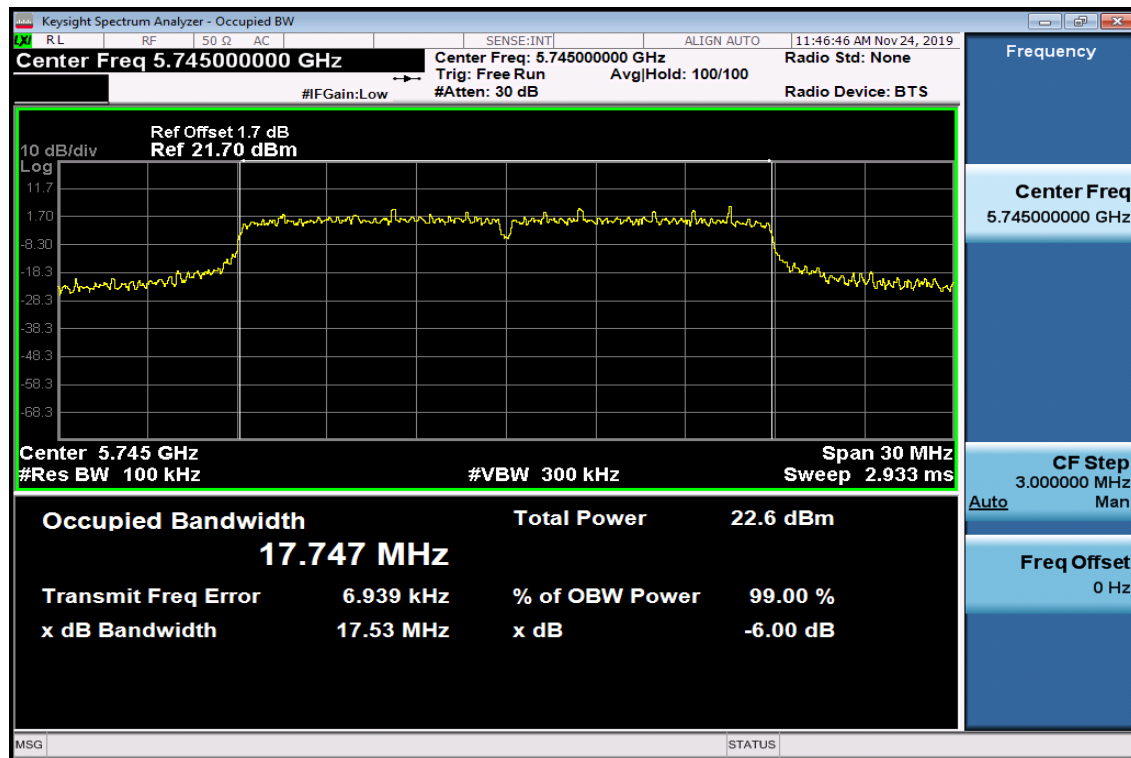

6dB Band Width Data CH-Mid

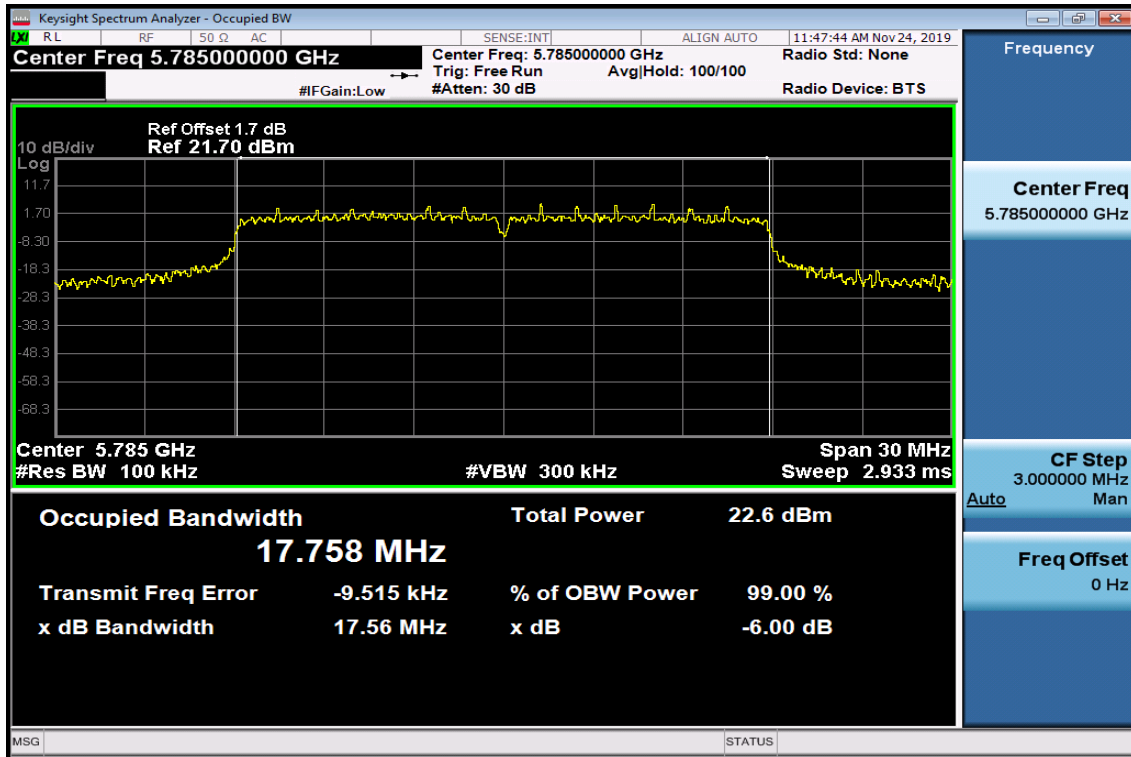

6dB Band Width Data CH-High

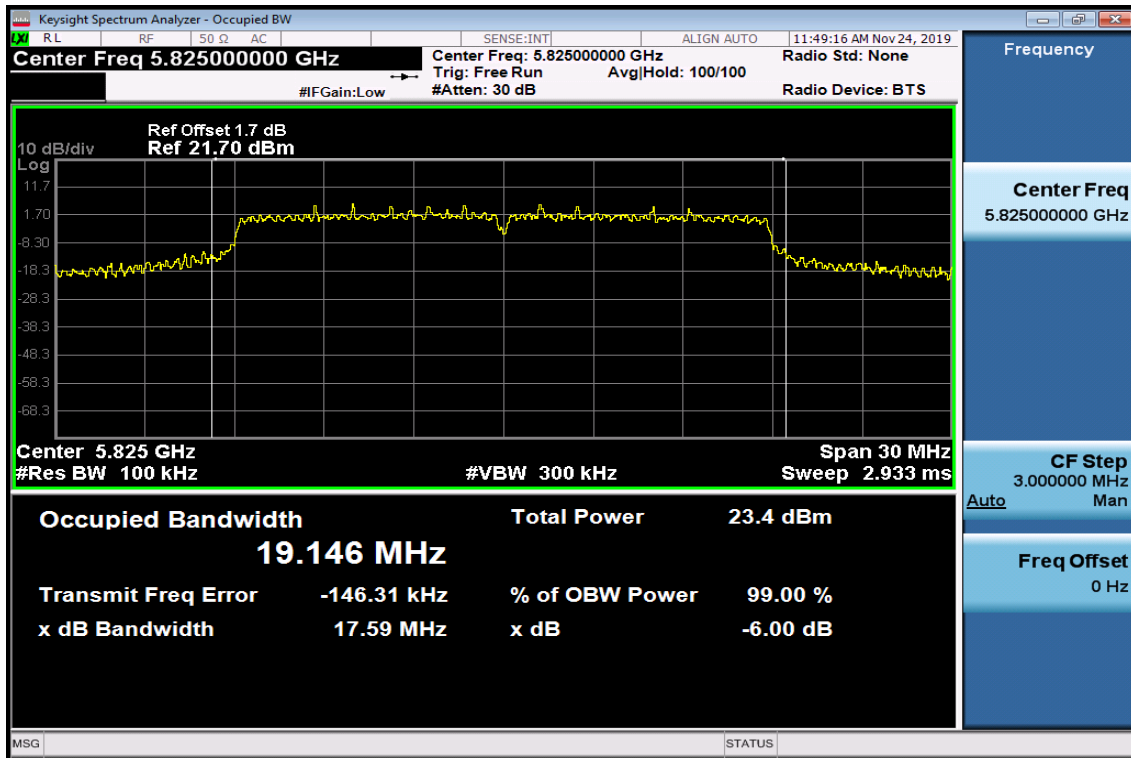

802.11n HT40

6dB Band Width Data CH-Low

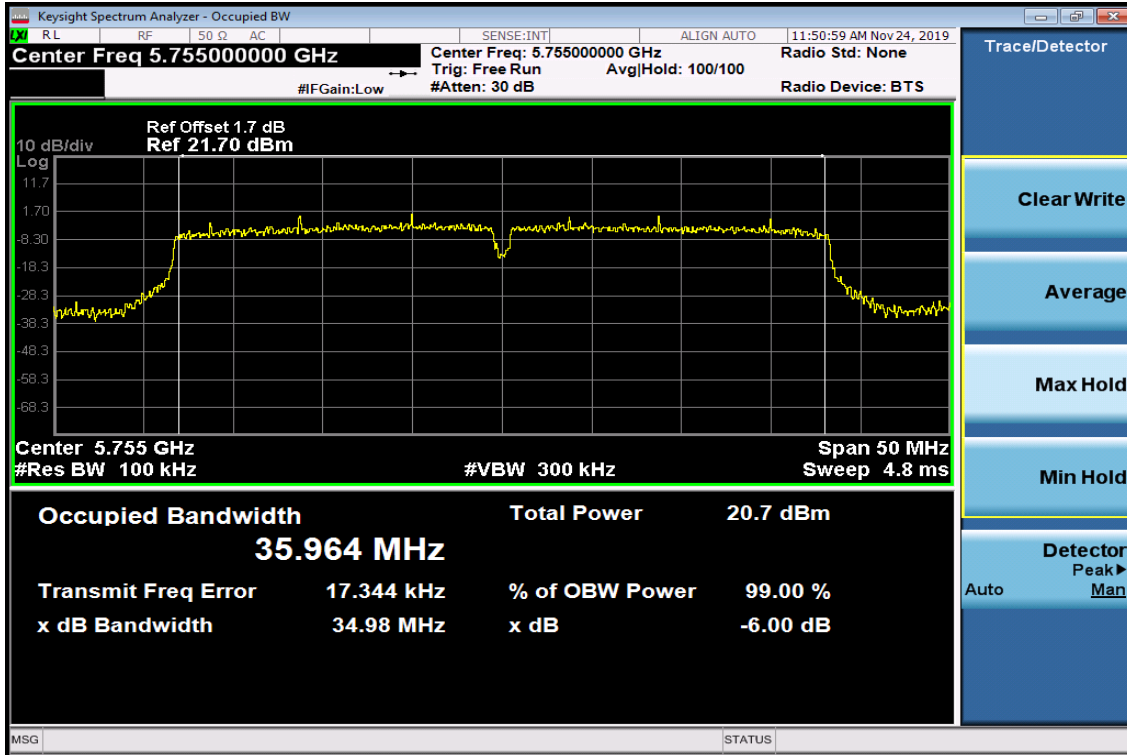

6dB Band Width Data CH-High

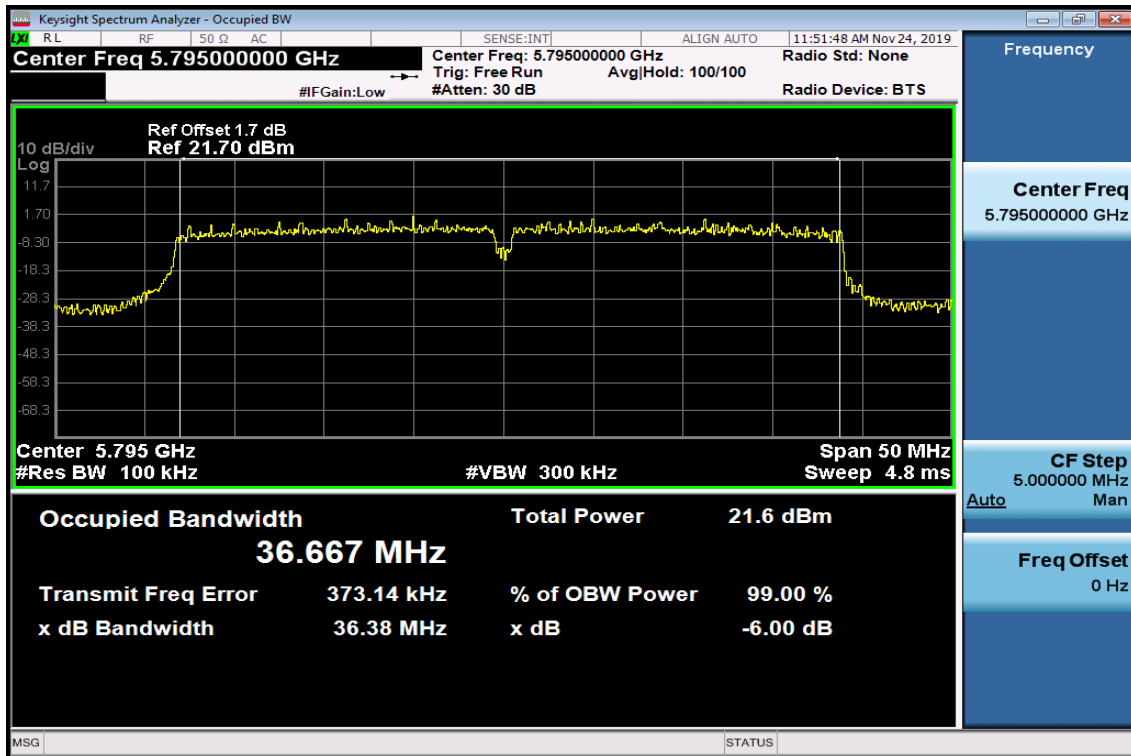

802.11ac VHT20 6dB Band Width Data CH-Low

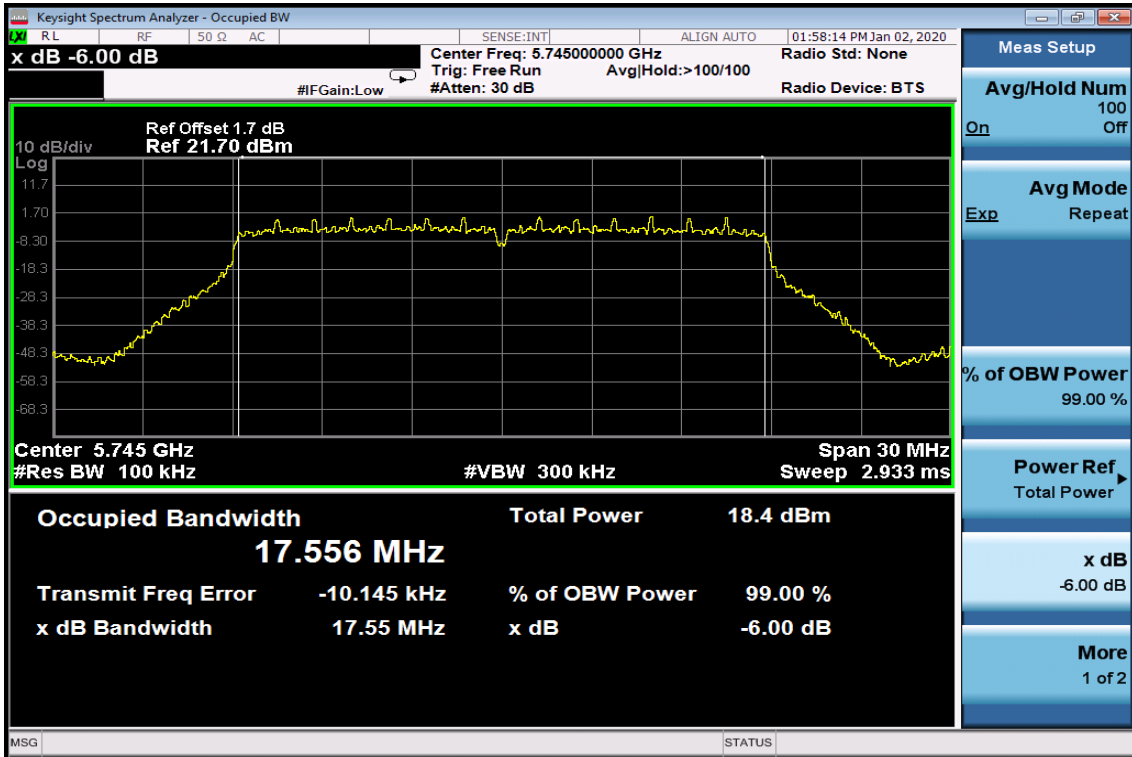

6dB Band Width Data CH-Mid

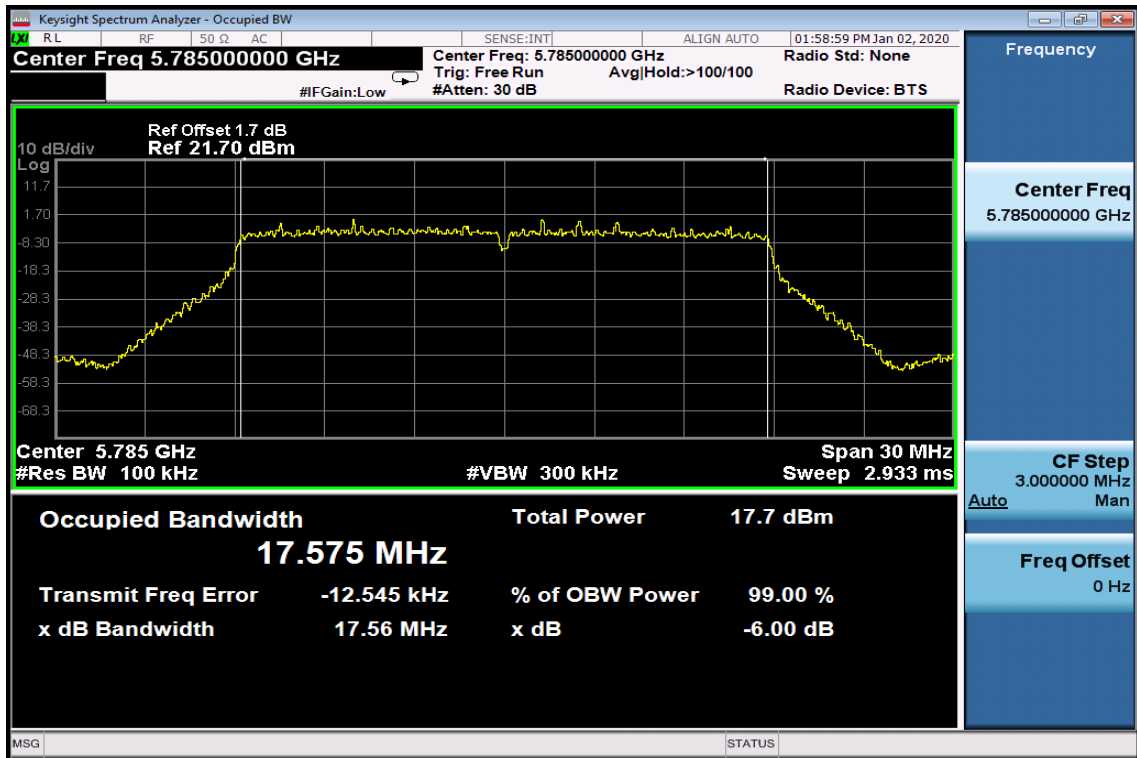

6dB Band Width Data CH-High

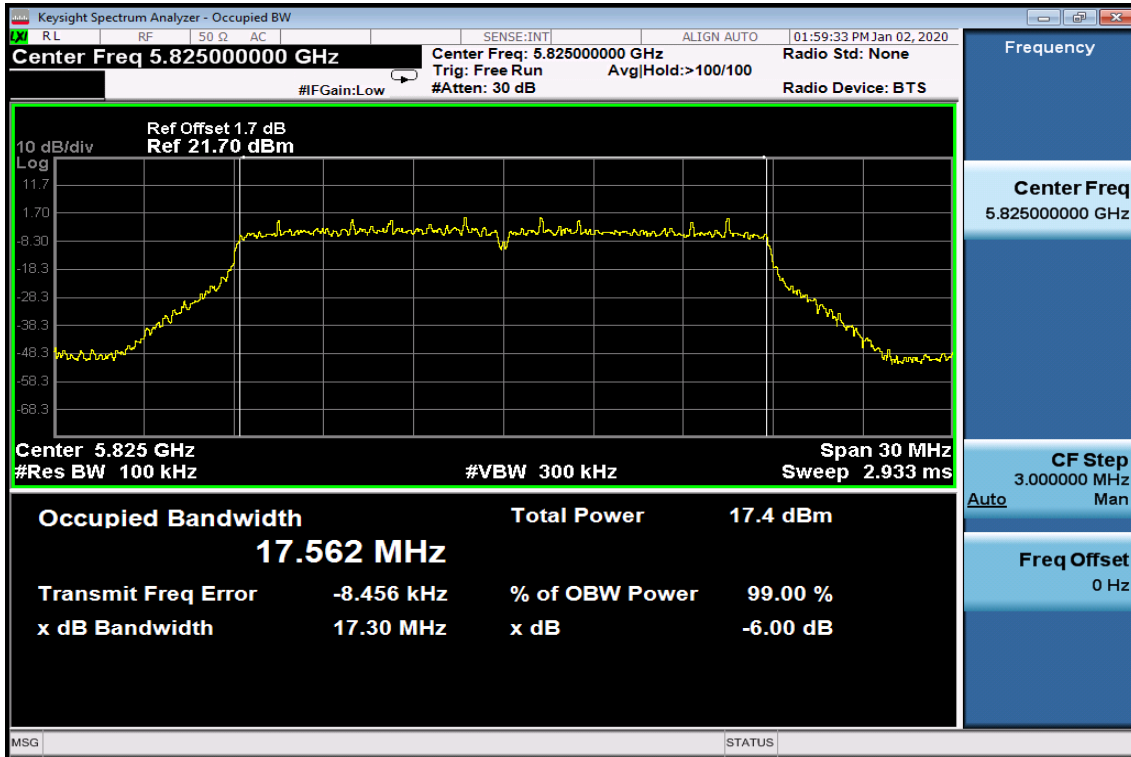

802.11ac VHT40

6dB Band Width Data CH-Low

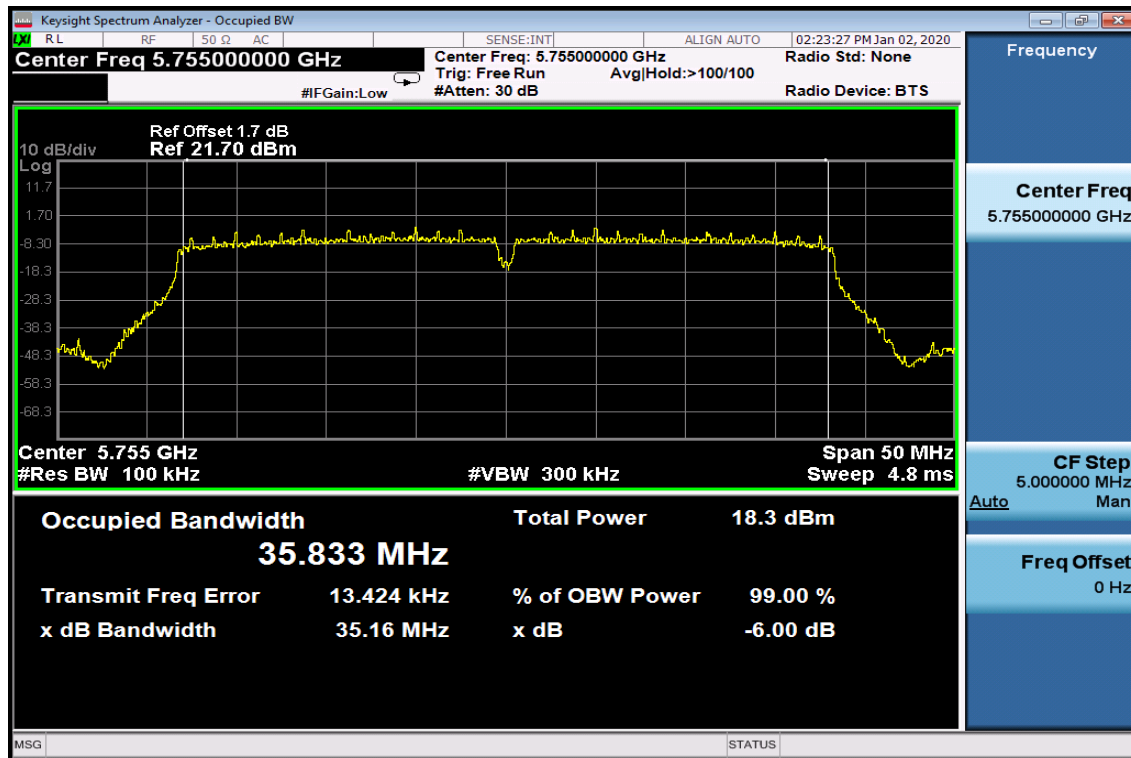

6dB Band Width Data CH-High

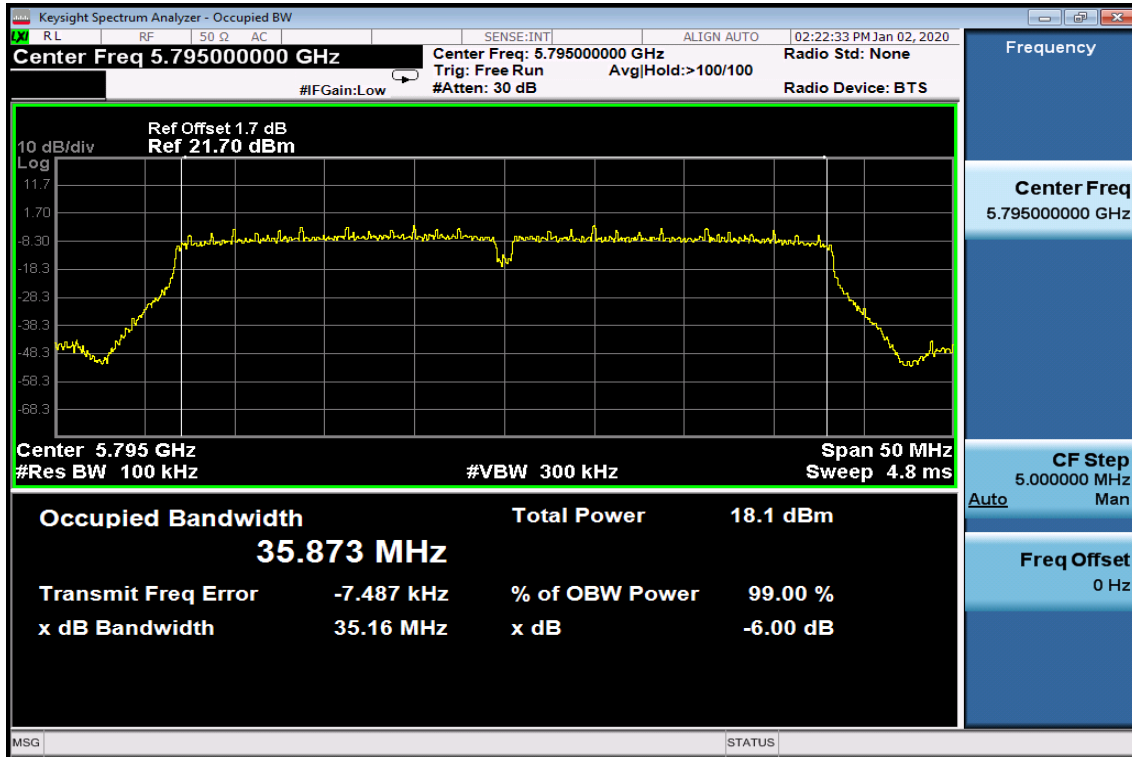

802.11ac VHT80

6dB Band Width Data

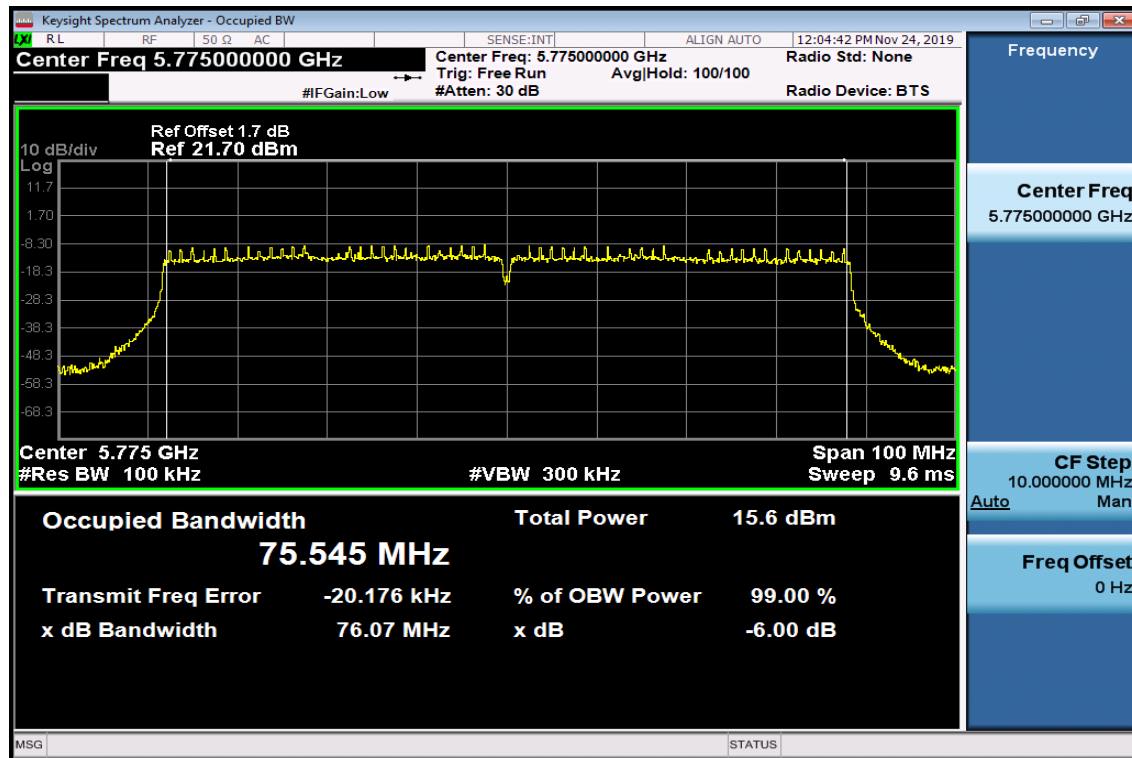

9. Undesirable Emission – Radiated Measurement

9.1. Standard Applicable

According to §15.407(b), Undesirable Emission Limits: Except as shown in Paragraph (b)(7) of this section, the peak emissions outside of the frequency bands of operation shall be attenuated in accordance with the following limits:

- (1) For transmitters operating in the 5.15-5.25 GHz band: all emissions outside of the 5.15-5.35 GHz band shall not exceed an e.i.r.p. of -27 dBm/MHz.
- (2) For transmitters operating in the 5.25-5.35 GHz band: all emissions outside of the 5.15-5.35 GHz band shall not exceed an e.i.r.p. of -27 dBm/MHz.
- (3) For transmitters operating in the 5.47-5.725 GHz band: all emissions outside of the 5.47-5.725 GHz band shall not exceed an e.i.r.p. of -27 dBm/MHz.
- (4) For transmitters operating in the 5.725-5.85 GHz band: all emissions within the frequency range from the band edge to 10 MHz above or below the band edge shall not exceed an e.i.r.p. of -17dBm/MHz; for frequencies 10 MHz or greater above or below the band edge, emissions shall not exceed an e.i.r.p. of -27 dBm/MHz.
- (5) The above emission measurements shall be performed using a minimum resolution bandwidth of 1 MHz. A lower resolution bandwidth may be employed near the band edge, when necessary, provided the measured energy is integrated to show the total power over 1 MHz.
- (6) Unwanted emissions below 1 GHz must comply with the general field strength limits set forth in Section 15.209. Further, any U-NII devices using an AC power line are required to comply also with the conducted limits set forth in Section 15.207.
- (7) The provisions of Section 15.205 of this part apply to intentional radiators operating under this section.
- (8) When measuring the emission limits, the nominal carrier frequency shall be adjusted as close to the upper and lower frequency band edges as the design of the equipment permits.

§15.205- RESTRICTED BANDS OF OPERATIONS

(a) Except as shown in paragraph (d) of this section, only spurious emissions are permitted in any of the frequency bands listed below:

MHz	MHz	MHz	GHz
0.090 - 0.110	16.42 - 16.423	399.9 - 410	4.5 - 5.15
¹ 0.495 - 0.505	16.69475 - 16.69525	608 - 614	5.35 - 5.46
2.1735 - 2.1905	16.80425 - 16.80475	960 - 1240	7.25 - 7.75
4.125 - 4.128	25.5 - 25.67	1300 - 1427	8.025 - 8.5
4.17725 - 4.17775	37.5 - 38.25	1435 - 1626.5	9.0 - 9.2
4.20725 - 4.20775	73 - 74.6	1645.5 - 1646.5	9.3 - 9.5
6.215 - 6.218	74.8 - 75.2	1660 - 1710	10.6 - 12.7
6.26775 - 6.26825	108 - 121.94	1718.8 - 1722.2	13.25 - 13.4
6.31175 - 6.31225	123 - 138	2200 - 2300	14.47 - 14.5
8.291 - 8.294	149.9 - 150.05	2310 - 2390	15.35 - 16.2
8.362 - 8.366	156.52475 -	2483.5 - 2500	17.7 - 21.4
8.37625 - 8.38675	156.52525	2655 - 2900	22.01 - 23.12
8.41425 - 8.41475	156.7 - 156.9	3260 - 3267	23.6 - 24.0
12.29 - 12.293	162.0125 - 167.17	3332 - 3339	31.2 - 31.8
12.51975 - 12.52025	167.72 - 173.2	3345.8 - 3358	36.43 - 36.5
12.57675 - 12.57725	240 - 285	3600 - 4400	(²)
13.36 - 13.41	322 - 335.4		

¹ Until February 1, 1999, this restricted band shall be 0.490-0.510 MHz.

² Above 38.6

(b) Except as provided in paragraphs (d) and (e), the field strength of emissions appearing within these frequency bands shall not exceed the limits shown in Section 15.209. At frequencies equal to or less than 1000 MHz, compliance with the limits in Section 15.209 shall be demonstrated using measurement instrumentation employing a CISPR quasi-peak detector. Above 1000 MHz, compliance with the emission limits in Section 15.209 shall be demonstrated based on the average value of the measured emissions. The provisions in Section 15.35 apply to these measurements.

§15.209- RADIATED EMISSION LIMITS: GENERAL REQUIREMENTS

FCC PART 15.209

MEASURING DISTANCE OF 3 METER		
FREQUENCY RANGE (MHz)	FIELD STRENGTH (Microvolts/m)	FIELD STRENGTH (dBuV/m)
30-88	100	40
88-216	150	43.5
216-960	200	46
Above 960	500	54

9.2. EUT Setup

1. The radiated emission tests were performed in the 3 meter open-test site, using the setup in accordance with the ANSI C63.10: 2013
2. The EUT was put in the front of the test table. The host PC system was placed on the center of the back edge on the test table. The peripherals like modem, monitor printer, K/B, and mouse were placed on the side of the host PC system. The rear of the EUT and peripherals were placed flushed with the rear of the tabletop.
3. The keyboard was placed directly in the front of the monitor, flushed with the front tabletop. The mouse was placed next to the Keyboard, flushed with the back of keyboard.
4. The spacing between the peripherals was 10 centimeters.
5. External I/O cables were draped along the edge of the test table and bundle when necessary.
6. The host PC system was connected with 120Vac/60Hz power source.

9.3. Measurement Procedure

1. The EUT was placed on a turn table which is 0.8m above ground plane.
2. The turn table shall rotate 360 degrees to determine the position of maximum emission level.
3. EUT is set 3m away from the receiving antenna which varied from 1m to 4m to find out the highest emissions.
4. Maximum procedure was performed on the six highest emissions to ensure EUT compliance.
5. And also, each emission was to be maximized by changing the polarization of receiving antenna both horizontal and vertical.
6. Repeat above procedures until all frequency measured were complete.

Refer to section F of KDB Document: KDB 789033 D02 General UNII Test Procedures New Rules v02r01

9.4. Test SET-UP (Block Diagram of Configuration)

(A) Radiated Emission Test Setup, Frequency below 1000MHz

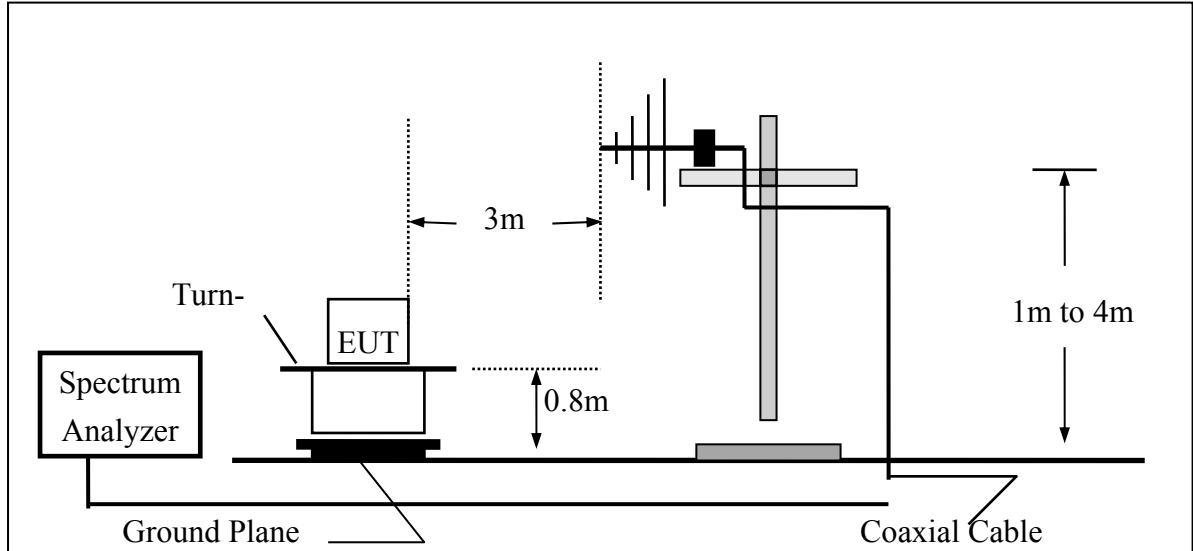

(B) Radiated Emission Test Setup Frequency above 1 GHz

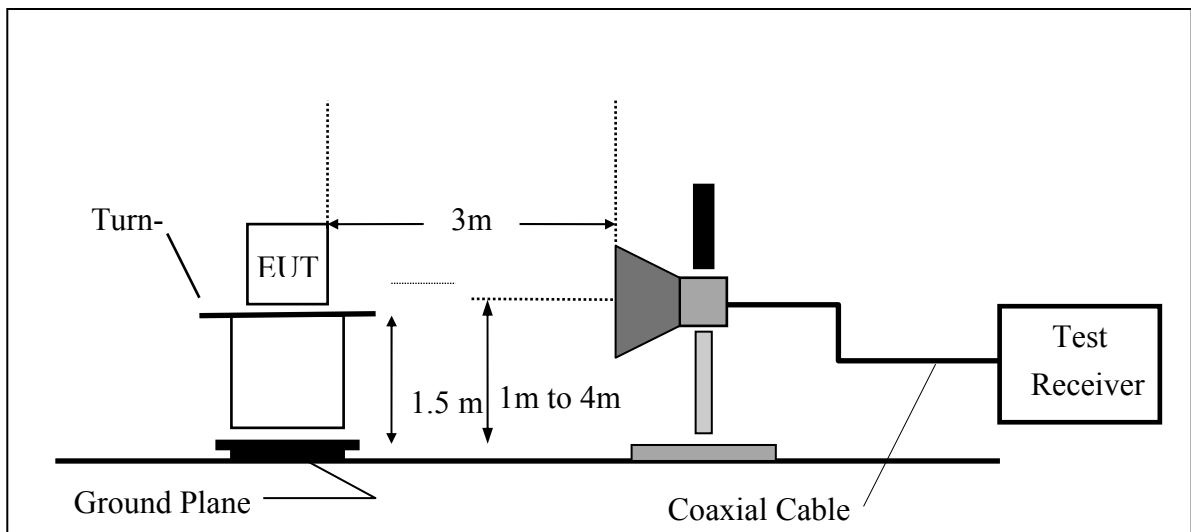

9.5. Measurement Equipment Used:

Chamber 19(966)					
Equipment Type	MFR	Model Number	Serial Number	Last Cal.	Cal Due.
Spectrum analyzer	R&S	FSP40	100116	01/10/2019	01/10/2020
EMI Receiver	R&S	ESR3	102461	08/08/2018	08/08/2020
Loop Antenna	EM	EM-6879	271	05/31/2019	05/31/2020
Bilog Antenna (30MHz-1GHz)	Schwarzbeck	VULB9168 w 5dB Att.	736	01/29/2019	01/29/2020
Horn antenna (1GHz-18GHz)	Schwarzbeck	9120D	9120D-1627	06/17/2019	06/17/2020
Horn antenna (18GHz-26GHz)	Com-power	AH-826	081001	11/21/2019	11/21/2020
Horn antenna (26GHz-40GHz)	Com-power	AH-640	100A	03/29/2019	03/29/2021
Preamplifier (9kHz-1GHz)	HP	8447F	3113A06362	01/14/2019	01/14/2020
Preamplifier (1GHz-26GHz)	Agilent	8449B	3008A02471	10/05/2019	10/05/2020
Preamplifier (26GHz-40GHz)	MITEQ	JS4-26004000-2 7-5A	818471	05/06/2019	05/06/2020
RF Cable (9kHz-18GHz)	HUBER SUHNER	Sucoflex 104A	MY1397/4A	01/17/2019	01/17/2020
RF Cable (18GHz-40GHz)	HUBER SUHNER	Sucoflex 102	27963/2&37421 /2	11/27/2017	11/27/2019
Signal Generator	Anritsu	MG3692A	20311	01/09/2019	01/09/2020
Test Software	Audix	E3 Ver:6.12023	N/A	N/A	N/A
Magnetic Field Meter	Combinova	MFM-10	645	10/16/2019	10/16/2020
Magnetic Field Meter	Combinova	MFM-1000	619	12/06/2019	12/06/2020
Electric Field Meter	Combinova	EFM-200	402	10/16/2019	10/16/2020
E-field probe	Narda / Wandel & Goltermann	EF-0691 + NBM-520	D-0135 + D-0526	03/02/2019	03/02/2020

9.6. Field Strength Calculation

The field strength is calculated by adding the Antenna Factor and Cable Factor and subtracting the Amplifier Gain and Duty Cycle Correction Factor (if any) from the measured reading. The basic equation with a sample calculation is as follows:

$$FS = RA + AF + CL - AG$$

Where	FS = Field Strength	CL = Cable Attenuation Factor (Cable Loss)
	RA = Reading Amplitude	AG = Amplifier Gain
	AF = Antenna Factor	

9.7. Measurement Result

Refer to attach tabular data sheets.

NOTE:

The resolution bandwidth and video bandwidth of test receiver/spectrum analyzer is 100kHz for Peak detection (PK) and Quasi-peak detection (QP) at frequency below 1GHz. And RBW 1MHz for frequency above 1GHz.

Radiated Spurious Emission Measurement Result (below 1GHz)

(Band UNII-1 a mode)

Operation Mode	TX MODE	Test Date	2019/12/07
Channel Number	CH Low	Test By	Weitin
Temperature	25 °C	Pol	Ver./Hor
Humidity	65 %		

No	Freq MHz	Reading dBuV	Factor dB	Level dBuV/m	Limit dBuV/m	Margin dB	Remark	Pol V/H
1	308.39	26.68	-3.68	23.00	46.00	-23.00	Peak	VERTICAL
2	469.41	27.29	-0.96	26.33	46.00	-19.67	Peak	VERTICAL
3	598.42	28.26	1.49	29.75	46.00	-16.25	Peak	VERTICAL
4	709.97	27.96	3.20	31.16	46.00	-14.84	Peak	VERTICAL
5	842.86	28.54	5.30	33.84	46.00	-12.16	Peak	VERTICAL
6	967.99	27.21	7.25	34.46	54.00	-19.54	Peak	VERTICAL
1	110.51	25.24	-8.70	16.54	43.50	-26.96	Peak	HORIZONTAL
2	274.44	24.21	-4.60	19.61	46.00	-26.39	Peak	HORIZONTAL
3	412.18	25.75	-1.82	23.93	46.00	-22.07	Peak	HORIZONTAL
4	612.97	25.98	1.67	27.65	46.00	-18.35	Peak	HORIZONTAL
5	709.97	26.08	3.20	29.28	46.00	-16.72	Peak	HORIZONTAL
6	911.73	24.68	6.15	30.83	46.00	-15.17	Peak	HORIZONTAL

Remark:

- 1 emission is 20dB lower, so that emission as measured between 9kHz to 30MHz is not reported
- 2 Measuring frequencies from the lowest internal frequency to the 1GHz.
- 3 Radiated emissions measured in frequency range from 9MHz to 1000MHz were made with an instrument detector setting 9-90kHz/110-490kHz using PK/AV and other Frequency Band using PK/QP
- 4 Measurement result within this frequency range shown “ - ” in the table above means the reading of emissions are attenuated more than 20dB below the permissible limits or the field strength is too small to be measured.

Radiated Spurious Emission Measurement Result (below 1GHz)

Operation Mode	TX MODE	Test Date	2019/12/07
Channel Number	CH Mid	Test By	Weitin
Temperature	25 °C	Pol	Ver./Hor
Humidity	65 %		

No	Freq MHz	Reading dBuV	Factor dB	Level dBuV/m	Limit dBuV/m	Margin dB	Remark	Pol V/H
1	178.41	25.27	-5.97	19.30	43.50	-24.20	Peak	VERTICAL
2	262.80	23.93	-5.09	18.84	46.00	-27.16	Peak	VERTICAL
3	361.74	27.13	-2.77	24.36	46.00	-21.64	Peak	VERTICAL
4	538.28	26.43	0.36	26.79	46.00	-19.21	Peak	VERTICAL
5	648.86	25.60	1.99	27.59	46.00	-18.41	Peak	VERTICAL
6	795.33	24.32	4.52	28.84	46.00	-17.16	Peak	VERTICAL
1	141.55	25.06	-5.65	19.41	43.50	-24.09	Peak	HORIZONTAL
2	278.32	24.79	-4.38	20.41	46.00	-25.59	Peak	HORIZONTAL
3	437.40	25.49	-1.23	24.26	46.00	-21.74	Peak	HORIZONTAL
4	536.34	26.17	0.34	26.51	46.00	-19.49	Peak	HORIZONTAL
5	721.61	25.68	3.28	28.96	46.00	-17.04	Peak	HORIZONTAL
6	861.29	25.88	5.50	31.38	46.00	-14.62	Peak	HORIZONTAL

Remark:

- 1 emission is 20dB lower, so that emission as measured between 9kHz to 30MHz is not reported
- 2 Measuring frequencies from the lowest internal frequency to the 1GHz.
- 3 Radiated emissions measured in frequency range from 9MHz to 1000MHz were made with an instrument detector setting 9-90kHz/110-490kHz using PK/AV and other Frequency Band using PK/QP
- 4 Measurement result within this frequency range shown “ - ” in the table above means the reading of emissions are attenuated more than 20dB below the permissible limits or the field strength is too small to be measured.

Radiated Spurious Emission Measurement Result (below 1GHz)

Operation Mode	TX MODE	Test Date	2019/12/07
Channel Number	CH High	Test By	Weitin
Temperature	25 °C	Pol	Ver./Hor
Humidity	65 %		

No	Freq MHz	Reading dBuV	Factor dB	Level dBuV/m	Limit dBuV/m	Margin dB	Remark	Pol V/H
1	159.01	26.73	-5.00	21.73	43.50	-21.77	Peak	VERTICAL
2	341.37	27.47	-3.02	24.45	46.00	-21.55	Peak	VERTICAL
3	491.72	27.34	-0.71	26.63	46.00	-19.37	Peak	VERTICAL
4	593.57	28.37	1.39	29.76	46.00	-16.24	Peak	VERTICAL
5	747.80	27.42	3.95	31.37	46.00	-14.63	Peak	VERTICAL
6	855.47	27.90	5.41	33.31	46.00	-12.69	Peak	VERTICAL
1	157.07	26.53	-5.04	21.49	43.50	-22.01	Peak	HORIZONTAL
2	287.05	26.79	-4.19	22.60	46.00	-23.40	Peak	HORIZONTAL
3	485.90	28.70	-0.79	27.91	46.00	-18.09	Peak	HORIZONTAL
4	614.91	28.52	1.68	30.20	46.00	-15.80	Peak	HORIZONTAL
5	712.88	27.98	3.21	31.19	46.00	-14.81	Peak	HORIZONTAL
6	844.80	28.15	5.31	33.46	46.00	-12.54	Peak	HORIZONTAL

Remark:

- 1 emission is 20dB lower, so that emission as measured between 9kHz to 30MHz is not reported
- 2 Measuring frequencies from the lowest internal frequency to the 1GHz.
- 3 Radiated emissions measured in frequency range from 9MHz to 1000MHz were made with an instrument detector setting 9-90kHz/110-490kHz using PK/AV and other Frequency Band using PK/QP
- 4 Measurement result within this frequency range shown “ - ” in the table above means the reading of emissions are attenuated more than 20dB below the permissible limits or the field strength is too small to be measured.

Radiated Spurious Emission Measurement Result (below 1GHz)

(Band UNII-1 802.11n HT20 mode)

Operation Mode	TX MODE	Test Date	2019/12/07
Channel Number	CH Low	Test By	Weitin
Temperature	25 °C	Pol	Ver./Hor
Humidity	65 %		

No	Freq MHz	Reading dBuV	Factor dB	Level dBuV/m	Limit dBuV/m	Margin dB	Remark	Pol V/H
1	164.83	27.74	-5.06	22.68	43.50	-20.82	Peak	VERTICAL
2	304.51	26.70	-3.75	22.95	46.00	-23.05	Peak	VERTICAL
3	359.80	27.71	-2.82	24.89	46.00	-21.11	Peak	VERTICAL
4	560.59	27.22	0.51	27.73	46.00	-18.27	Peak	VERTICAL
5	616.85	28.66	1.68	30.34	46.00	-15.66	Peak	VERTICAL
6	827.34	28.86	5.10	33.96	46.00	-12.04	Peak	VERTICAL
1	162.89	26.31	-5.03	21.28	43.50	-22.22	Peak	HORIZONTAL
2	325.85	26.59	-3.27	23.32	46.00	-22.68	Peak	HORIZONTAL
3	446.13	27.07	-1.12	25.95	46.00	-20.05	Peak	HORIZONTAL
4	547.98	27.37	0.46	27.83	46.00	-18.17	Peak	HORIZONTAL
5	597.45	28.09	1.47	29.56	46.00	-16.44	Peak	HORIZONTAL
6	739.07	28.07	3.80	31.87	46.00	-14.13	Peak	HORIZONTAL

Remark:

- 1 emission is 20dB lower, so that emission as measured between 9kHz to 30MHz is not reported
- 2 Measuring frequencies from the lowest internal frequency to the 1GHz.
- 3 Radiated emissions measured in frequency range from 9MHz to 1000MHz were made with an instrument detector setting 9-90kHz/110-490kHz using PK/AV and other Frequency Band using PK/QP
- 4 Measurement result within this frequency range shown “ - ” in the table above means the reading of emissions are attenuated more than 20dB below the permissible limits or the field strength is too small to be measured.

Radiated Spurious Emission Measurement Result (below 1GHz)

Operation Mode	TX MODE	Test Date	2019/12/07
Channel Number	CH Mid	Test By	Weitin
Temperature	25 °C	Pol	Ver./Hor
Humidity	65 %		

No	Freq MHz	Reading dBuV	Factor dB	Level dBuV/m	Limit dBuV/m	Margin dB	Remark	Pol V/H
1	151.25	27.08	-5.22	21.86	43.50	-21.64	Peak	VERTICAL
2	324.88	26.20	-3.30	22.90	46.00	-23.10	Peak	VERTICAL
3	446.13	27.83	-1.12	26.71	46.00	-19.29	Peak	VERTICAL
4	591.63	28.24	1.34	29.58	46.00	-16.42	Peak	VERTICAL
5	694.45	28.17	3.02	31.19	46.00	-14.81	Peak	VERTICAL
6	837.04	28.30	5.25	33.55	46.00	-12.45	Peak	VERTICAL
1	165.80	26.56	-5.09	21.47	43.50	-22.03	Peak	HORIZONTAL
2	343.31	28.25	-3.02	25.23	46.00	-20.77	Peak	HORIZONTAL
3	496.57	29.01	-0.67	28.34	46.00	-17.66	Peak	HORIZONTAL
4	624.61	29.06	1.76	30.82	46.00	-15.18	Peak	HORIZONTAL
5	691.54	27.40	2.95	30.35	46.00	-15.65	Peak	HORIZONTAL
6	825.40	28.16	5.07	33.23	46.00	-12.77	Peak	HORIZONTAL

Remark:

- 1 emission is 20dB lower, so that emission as measured between 9kHz to 30MHz is not reported
- 2 Measuring frequencies from the lowest internal frequency to the 1GHz.
- 3 Radiated emissions measured in frequency range from 9MHz to 1000MHz were made with an instrument detector setting 9-90kHz/110-490kHz using PK/AV and other Frequency Band using PK/QP
- 4 Measurement result within this frequency range shown “ - ” in the table above means the reading of emissions are attenuated more than 20dB below the permissible limits or the field strength is too small to be measured.

Radiated Spurious Emission Measurement Result (below 1GHz)

Operation Mode	TX MODE	Test Date	2019/12/07
Channel Number	CH High	Test By	Weitin
Temperature	25 °C	Pol	Ver./Hor
Humidity	65 %		

No	Freq MHz	Reading dBuV	Factor dB	Level dBuV/m	Limit dBuV/m	Margin dB	Remark	Pol V/H
1	174.53	28.18	-5.60	22.58	43.50	-20.92	Peak	VERTICAL
2	344.28	27.74	-3.01	24.73	46.00	-21.27	Peak	VERTICAL
3	460.68	26.98	-0.92	26.06	46.00	-19.94	Peak	VERTICAL
4	560.59	27.42	0.51	27.93	46.00	-18.07	Peak	VERTICAL
5	616.85	28.48	1.68	30.16	46.00	-15.84	Peak	VERTICAL
6	773.02	27.02	4.30	31.32	46.00	-14.68	Peak	VERTICAL
1	160.95	25.91	-4.99	20.92	43.50	-22.58	Peak	HORIZONTAL
2	317.12	26.08	-3.50	22.58	46.00	-23.42	Peak	HORIZONTAL
3	431.58	25.97	-1.37	24.60	46.00	-21.40	Peak	HORIZONTAL
4	556.71	27.03	0.49	27.52	46.00	-18.48	Peak	HORIZONTAL
5	606.18	28.08	1.60	29.68	46.00	-16.32	Peak	HORIZONTAL
6	799.21	27.01	4.58	31.59	46.00	-14.41	Peak	HORIZONTAL

Remark:

- 1 emission is 20dB lower, so that emission as measured between 9kHz to 30MHz is not reported
- 2 Measuring frequencies from the lowest internal frequency to the 1GHz.
- 3 Radiated emissions measured in frequency range from 9MHz to 1000MHz were made with an instrument detector setting 9-90kHz/110-490kHz using PK/AV and other Frequency Band using PK/QP
- 4 Measurement result within this frequency range shown “ - ” in the table above means the reading of emissions are attenuated more than 20dB below the permissible limits or the field strength is too small to be measured.

Radiated Spurious Emission Measurement Result (below 1GHz)

(Band UNII-1 HT40 mode)

Operation Mode	TX MODE	Test Date	2019/12/07
Channel Number	CH Low	Test By	Weitin
Temperature	25 °C	Pol	Ver./Hor
Humidity	65 %		

No	Freq MHz	Reading dBuV	Factor dB	Level dBuV/m	Limit dBuV/m	Margin dB	Remark	Pol V/H
1	162.89	26.47	-5.03	21.44	43.50	-22.06	Peak	VERTICAL
2	282.20	25.40	-4.27	21.13	46.00	-24.87	Peak	VERTICAL
3	368.53	27.05	-2.53	24.52	46.00	-21.48	Peak	VERTICAL
4	463.59	27.21	-0.94	26.27	46.00	-19.73	Peak	VERTICAL
5	586.78	28.37	1.22	29.59	46.00	-16.41	Peak	VERTICAL
6	729.37	28.22	3.48	31.70	46.00	-14.30	Peak	VERTICAL
1	167.74	27.19	-5.13	22.06	43.50	-21.44	Peak	HORIZONTAL
2	297.72	25.51	-3.89	21.62	46.00	-24.38	Peak	HORIZONTAL
3	421.88	26.14	-1.64	24.50	46.00	-21.50	Peak	HORIZONTAL
4	498.51	31.11	-0.65	30.46	46.00	-15.54	Peak	HORIZONTAL
5	621.70	29.15	1.72	30.87	46.00	-15.13	Peak	HORIZONTAL
6	838.01	29.06	5.26	34.32	46.00	-11.68	Peak	HORIZONTAL

Remark:

- 1 emission is 20dB lower, so that emission as measured between 9kHz to 30MHz is not reported
- 2 Measuring frequencies from the lowest internal frequency to the 1GHz.
- 3 Radiated emissions measured in frequency range from 9MHz to 1000MHz were made with an instrument detector setting 9-90kHz/110-490kHz using PK/AV and other Frequency Band using PK/QP
- 4 Measurement result within this frequency range shown “ - ” in the table above means the reading of emissions are attenuated more than 20dB below the permissible limits or the field strength is too small to be measured.

Radiated Spurious Emission Measurement Result (below 1GHz)

Operation Mode	TX MODE	Test Date	2019/12/07
Channel Number	CH High	Test By	Weitin
Temperature	25 °C	Pol	Ver./Hor
Humidity	65 %		

No	Freq MHz	Reading dBuV	Factor dB	Level dBuV/m	Limit dBuV/m	Margin dB	Remark	Pol V/H
1	153.19	26.94	-5.16	21.78	43.50	-21.72	Peak	VERTICAL
2	341.37	27.07	-3.02	24.05	46.00	-21.95	Peak	VERTICAL
3	467.47	27.60	-0.95	26.65	46.00	-19.35	Peak	VERTICAL
4	498.51	36.32	-0.65	35.67	46.00	-10.33	Peak	VERTICAL
5	577.08	28.41	0.92	29.33	46.00	-16.67	Peak	VERTICAL
6	835.10	28.76	5.21	33.97	46.00	-12.03	Peak	VERTICAL
1	166.77	27.33	-5.11	22.22	43.50	-21.28	Peak	HORIZONTAL
2	363.68	26.96	-2.69	24.27	46.00	-21.73	Peak	HORIZONTAL
3	497.54	31.08	-0.67	30.41	46.00	-15.59	Peak	HORIZONTAL
4	519.85	31.58	0.05	31.63	46.00	-14.37	Peak	HORIZONTAL
5	701.24	28.06	3.15	31.21	46.00	-14.79	Peak	HORIZONTAL
6	819.58	28.76	4.98	33.74	46.00	-12.26	Peak	HORIZONTAL

Remark:

- 1 emission is 20dB lower, so that emission as measured between 9kHz to 30MHz is not reported
- 2 Measuring frequencies from the lowest internal frequency to the 1GHz.
- 3 Radiated emissions measured in frequency range from 9MHz to 1000MHz were made with an instrument detector setting 9-90kHz/110-490kHz using PK/AV and other Frequency Band using PK/QP
- 4 Measurement result within this frequency range shown “ - ” in the table above means the reading of emissions are attenuated more than 20dB below the permissible limits or the field strength is too small to be measured.

Radiated Spurious Emission Measurement Result (below 1GHz)

(Band UNII-1, 802.11ac VHT80mode)

Operation Mode	TX MODE	Test Date	2019/12/07
Channel Number	CH Low	Test By	Weitin
Temperature	25 °C	Pol	Ver./Hor
Humidity	65 %		

No	Freq MHz	Reading dBuV	Factor dB	Level dBuV/m	Limit dBuV/m	Margin dB	Remark	Pol V/H
1	158.04	26.68	-5.02	21.66	43.50	-21.84	Peak	VERTICAL
2	345.25	27.37	-3.00	24.37	46.00	-21.63	Peak	VERTICAL
3	498.51	29.49	-0.65	28.84	46.00	-17.16	Peak	VERTICAL
4	592.60	28.04	1.37	29.41	46.00	-16.59	Peak	VERTICAL
5	713.85	27.54	3.22	30.76	46.00	-15.24	Peak	VERTICAL
6	833.16	29.29	5.18	34.47	46.00	-11.53	Peak	VERTICAL
1	158.04	27.78	-5.02	22.76	43.50	-20.74	Peak	HORIZONTAL
2	342.34	26.79	-3.02	23.77	46.00	-22.23	Peak	HORIZONTAL
3	489.78	30.65	-0.72	29.93	46.00	-16.07	Peak	HORIZONTAL
4	618.79	28.24	1.68	29.92	46.00	-16.08	Peak	HORIZONTAL
5	748.77	27.23	3.96	31.19	46.00	-14.81	Peak	HORIZONTAL
6	822.49	28.47	5.02	33.49	46.00	-12.51	Peak	HORIZONTAL

Remark:

- 1 emission is 20dB lower, so that emission as measured between 9kHz to 30MHz is not reported
- 2 Measuring frequencies from the lowest internal frequency to the 1GHz.
- 3 Radiated emissions measured in frequency range from 9MHz to 1000MHz were made with an instrument detector setting 9-90kHz/110-490kHz using PK/AV and other Frequency Band using PK/QP
- 4 Measurement result within this frequency range shown “ - ” in the table above means the reading of emissions are attenuated more than 20dB below the permissible limits or the field strength is too small to be measured.

Radiated Spurious Emission Measurement Result (below 1GHz)

(Band UNII-3, 802.11a mode)

Operation Mode	TX MODE	Test Date	2019/12/07
Channel Number	CH Low	Test By	Weitin
Temperature	25 °C	Pol	Ver./Hor
Humidity	65 %		

No	Freq MHz	Reading dBuV	Factor dB	Level dBuV/m	Limit dBuV/m	Margin dB	Remark	Pol V/H
1	167.74	26.99	-5.13	21.86	43.50	-21.64	Peak	VERTICAL
2	345.25	26.97	-3.00	23.97	46.00	-22.03	Peak	VERTICAL
3	497.54	32.47	-0.67	31.80	46.00	-14.20	Peak	VERTICAL
4	621.70	28.68	1.72	30.40	46.00	-15.60	Peak	VERTICAL
5	804.06	27.78	4.69	32.47	46.00	-13.53	Peak	VERTICAL
6	871.96	28.70	5.65	34.35	46.00	-11.65	Peak	VERTICAL
1	153.19	26.92	-5.16	21.76	43.50	-21.74	Peak	HORIZONTAL
2	321.00	26.54	-3.39	23.15	46.00	-22.85	Peak	HORIZONTAL
3	484.93	27.86	-0.80	27.06	46.00	-18.94	Peak	HORIZONTAL
4	497.54	34.07	-0.67	33.40	46.00	-12.60	Peak	HORIZONTAL
5	520.82	30.94	0.08	31.02	46.00	-14.98	Peak	HORIZONTAL
6	753.62	27.53	4.06	31.59	46.00	-14.41	Peak	HORIZONTAL

Remark:

- 1 emission is 20dB lower, so that emission as measured between 9kHz to 30MHz is not reported
- 2 Measuring frequencies from the lowest internal frequency to the 1GHz.
- 3 Radiated emissions measured in frequency range from 9MHz to 1000MHz were made with an instrument detector setting 9-90kHz/110-490kHz using PK/AV and other Frequency Band using PK/QP
- 4 Measurement result within this frequency range shown “ - ” in the table above means the reading of emissions are attenuated more than 20dB below the permissible limits or the field strength is too small to be measured.

Radiated Spurious Emission Measurement Result (below 1GHz)

Operation Mode	TX MODE	Test Date	2019/12/07
Channel Number	CH Mid	Test By	Weitin
Temperature	25 °C	Pol	Ver./Hor
Humidity	65 %		

No	Freq MHz	Reading dBuV	Factor dB	Level dBuV/m	Limit dBuV/m	Margin dB	Remark	Pol V/H
1	165.80	26.94	-5.09	21.85	43.50	-21.65	Peak	VERTICAL
2	345.25	27.13	-3.00	24.13	46.00	-21.87	Peak	VERTICAL
3	497.54	34.21	-0.67	33.54	46.00	-12.46	Peak	VERTICAL
4	589.69	29.05	1.30	30.35	46.00	-15.65	Peak	VERTICAL
5	707.06	27.59	3.18	30.77	46.00	-15.23	Peak	VERTICAL
6	855.47	28.28	5.41	33.69	46.00	-12.31	Peak	VERTICAL
1	157.07	27.06	-5.04	22.02	43.50	-21.48	Peak	HORIZONTAL
2	339.43	27.28	-3.03	24.25	46.00	-21.75	Peak	HORIZONTAL
3	515.00	29.48	-0.14	29.34	46.00	-16.66	Peak	HORIZONTAL
4	633.34	27.68	1.87	29.55	46.00	-16.45	Peak	HORIZONTAL
5	748.77	27.31	3.96	31.27	46.00	-14.73	Peak	HORIZONTAL
6	827.34	28.43	5.10	33.53	46.00	-12.47	Peak	HORIZONTAL

Remark:

- 1 emission is 20dB lower, so that emission as measured between 9kHz to 30MHz is not reported
- 2 Measuring frequencies from the lowest internal frequency to the 1GHz.
- 3 Radiated emissions measured in frequency range from 9MHz to 1000MHz were made with an instrument detector setting 9-90kHz/110-490kHz using PK/AV and other Frequency Band using PK/QP
- 4 Measurement result within this frequency range shown “ - ” in the table above means the reading of emissions are attenuated more than 20dB below the permissible limits or the field strength is too small to be measured.

Radiated Spurious Emission Measurement Result (below 1GHz)

Operation Mode	TX MODE	Test Date	2019/12/07
Channel Number	CH High	Test By	Weitin
Temperature	25 °C	Pol	Ver./Hor
Humidity	65 %		

No	Freq MHz	Reading dBuV	Factor dB	Level dBuV/m	Limit dBuV/m	Margin dB	Remark	Pol V/H
1	149.31	27.24	-5.28	21.96	43.50	-21.54	Peak	VERTICAL
2	321.00	25.65	-3.39	22.26	46.00	-23.74	Peak	VERTICAL
3	498.51	30.93	-0.65	30.28	46.00	-15.72	Peak	VERTICAL
4	633.34	28.02	1.87	29.89	46.00	-16.11	Peak	VERTICAL
5	835.10	28.56	5.21	33.77	46.00	-12.23	Peak	VERTICAL
6	878.75	28.17	5.76	33.93	46.00	-12.07	Peak	VERTICAL
1	158.04	27.78	-5.02	22.76	43.50	-20.74	Peak	HORIZONTAL
2	299.66	27.71	-3.82	23.89	46.00	-22.11	Peak	HORIZONTAL
3	498.51	34.12	-0.65	33.47	46.00	-12.53	Peak	HORIZONTAL
4	625.58	29.30	1.77	31.07	46.00	-14.93	Peak	HORIZONTAL
5	828.31	28.87	5.11	33.98	46.00	-12.02	Peak	HORIZONTAL
6	952.47	27.13	7.02	34.15	46.00	-11.85	Peak	HORIZONTAL

Remark:

- 1 emission is 20dB lower, so that emission as measured between 9kHz to 30MHz is not reported
- 2 Measuring frequencies from the lowest internal frequency to the 1GHz.
- 3 Radiated emissions measured in frequency range from 9MHz to 1000MHz were made with an instrument detector setting 9-90kHz/110-490kHz using PK/AV and other Frequency Band using PK/QP
- 4 Measurement result within this frequency range shown “ - ” in the table above means the reading of emissions are attenuated more than 20dB below the permissible limits or the field strength is too small to be measured.

Radiated Spurious Emission Measurement Result (below 1GHz)
(Band UNII-3, 802.11n HT20 mode)

Operation Mode	TX MODE	Test Date	2019/12/07
Channel Number	CH Low	Test By	Weitin
Temperature	25 °C	Pol	Ver./Hor
Humidity	65 %		

No	Freq MHz	Reading dBuV	Factor dB	Level dBuV/m	Limit dBuV/m	Margin dB	Remark	Pol V/H
1	157.07	26.95	-5.04	21.91	43.50	-21.59	Peak	VERTICAL
2	297.72	25.97	-3.89	22.08	46.00	-23.92	Peak	VERTICAL
3	388.90	27.07	-2.18	24.89	46.00	-21.11	Peak	VERTICAL
4	528.58	27.17	0.24	27.41	46.00	-18.59	Peak	VERTICAL
5	633.34	27.53	1.87	29.40	46.00	-16.60	Peak	VERTICAL
6	846.74	28.62	5.31	33.93	46.00	-12.07	Peak	VERTICAL
1	148.34	26.13	-5.33	20.80	43.50	-22.70	Peak	HORIZONTAL
2	318.09	26.63	-3.47	23.16	46.00	-22.84	Peak	HORIZONTAL
3	425.76	27.16	-1.54	25.62	46.00	-20.38	Peak	HORIZONTAL
4	539.25	26.43	0.37	26.80	46.00	-19.20	Peak	HORIZONTAL
5	628.49	28.42	1.80	30.22	46.00	-15.78	Peak	HORIZONTAL
6	843.83	29.09	5.31	34.40	46.00	-11.60	Peak	HORIZONTAL

Remark:

- 1 emission is 20dB lower, so that emission as measured between 9kHz to 30MHz is not reported
- 2 Measuring frequencies from the lowest internal frequency to the 1GHz.
- 3 Radiated emissions measured in frequency range from 9MHz to 1000MHz were made with an instrument detector setting 9-90kHz/110-490kHz using PK/AV and other Frequency Band using PK/QP
- 4 Measurement result within this frequency range shown “ - ” in the table above means the reading of emissions are attenuated more than 20dB below the permissible limits or the field strength is too small to be measured.

Radiated Spurious Emission Measurement Result (below 1GHz)

Operation Mode	TX MODE	Test Date	2019/12/07
Channel Number	CH Mid	Test By	Weitin
Temperature	25 °C	Pol	Ver./Hor
Humidity	65 %		

No	Freq MHz	Reading dBuV	Factor dB	Level dBuV/m	Limit dBuV/m	Margin dB	Remark	Pol V/H
1	160.95	26.47	-4.99	21.48	43.50	-22.02	Peak	VERTICAL
2	379.20	27.77	-2.34	25.43	46.00	-20.57	Peak	VERTICAL
3	525.67	27.51	0.17	27.68	46.00	-18.32	Peak	VERTICAL
4	615.88	27.46	1.68	29.14	46.00	-16.86	Peak	VERTICAL
5	736.16	26.95	3.70	30.65	46.00	-15.35	Peak	VERTICAL
6	880.69	26.83	5.78	32.61	46.00	-13.39	Peak	VERTICAL
1	147.37	26.94	-5.38	21.56	43.50	-21.94	Peak	HORIZONTAL
2	312.27	26.93	-3.61	23.32	46.00	-22.68	Peak	HORIZONTAL
3	466.50	28.15	-0.94	27.21	46.00	-18.79	Peak	HORIZONTAL
4	599.39	27.73	1.51	29.24	46.00	-16.76	Peak	HORIZONTAL
5	705.12	27.12	3.17	30.29	46.00	-15.71	Peak	HORIZONTAL
6	838.01	27.80	5.26	33.06	46.00	-12.94	Peak	HORIZONTAL

Remark:

- 1 emission is 20dB lower, so that emission as measured between 9kHz to 30MHz is not reported
- 2 Measuring frequencies from the lowest internal frequency to the 1GHz.
- 3 Radiated emissions measured in frequency range from 9MHz to 1000MHz were made with an instrument detector setting 9-90kHz/110-490kHz using PK/AV and other Frequency Band using PK/QP
- 4 Measurement result within this frequency range shown “ - ” in the table above means the reading of emissions are attenuated more than 20dB below the permissible limits or the field strength is too small to be measured.

Radiated Spurious Emission Measurement Result (below 1GHz)

Operation Mode	TX MODE	Test Date	2019/12/07
Channel Number	CH High	Test By	Weitin
Temperature	25 °C	Pol	Ver./Hor
Humidity	65 %		

No	Freq MHz	Reading dBuV	Factor dB	Level dBuV/m	Limit dBuV/m	Margin dB	Remark	Pol V/H
1	167.74	26.73	-5.13	21.60	43.50	-21.90	Peak	VERTICAL
2	361.74	27.60	-2.77	24.83	46.00	-21.17	Peak	VERTICAL
3	497.54	28.84	-0.67	28.17	46.00	-17.83	Peak	VERTICAL
4	580.96	28.80	1.03	29.83	46.00	-16.17	Peak	VERTICAL
5	633.34	27.24	1.87	29.11	46.00	-16.89	Peak	VERTICAL
6	838.98	28.94	5.27	34.21	46.00	-11.79	Peak	VERTICAL
1	148.34	26.21	-5.33	20.88	43.50	-22.62	Peak	HORIZONTAL
2	275.41	26.46	-4.54	21.92	46.00	-24.08	Peak	HORIZONTAL
3	377.26	26.91	-2.36	24.55	46.00	-21.45	Peak	HORIZONTAL
4	508.21	27.56	-0.39	27.17	46.00	-18.83	Peak	HORIZONTAL
5	632.37	27.71	1.85	29.56	46.00	-16.44	Peak	HORIZONTAL
6	854.50	28.04	5.41	33.45	46.00	-12.55	Peak	HORIZONTAL

Remark:

- 1 emission is 20dB lower, so that emission as measured between 9kHz to 30MHz is not reported
- 2 Measuring frequencies from the lowest internal frequency to the 1GHz.
- 3 Radiated emissions measured in frequency range from 9MHz to 1000MHz were made with an instrument detector setting 9-90kHz/110-490kHz using PK/AV and other Frequency Band using PK/QP
- 4 Measurement result within this frequency range shown “ - ” in the table above means the reading of emissions are attenuated more than 20dB below the permissible limits or the field strength is too small to be measured.

Radiated Spurious Emission Measurement Result (below 1GHz)

(Band UNII-3, 802.11n HT40 mode)

Operation Mode	TX MODE	Test Date	2019/12/07
Channel Number	CH Low	Test By	Weitin
Temperature	25 °C	Pol	Ver./Hor
Humidity	65 %		

No	Freq MHz	Reading dBuV	Factor dB	Level dBuV/m	Limit dBuV/m	Margin dB	Remark	Pol V/H
1	160.95	27.64	-4.99	22.65	43.50	-20.85	Peak	VERTICAL
2	341.37	26.94	-3.02	23.92	46.00	-22.08	Peak	VERTICAL
3	499.48	33.99	-0.66	33.33	46.00	-12.67	Peak	VERTICAL
4	610.06	28.06	1.65	29.71	46.00	-16.29	Peak	VERTICAL
5	720.64	28.59	3.26	31.85	46.00	-14.15	Peak	VERTICAL
6	845.77	28.03	5.31	33.34	46.00	-12.66	Peak	VERTICAL
1	157.07	27.13	-5.04	22.09	43.50	-21.41	Peak	HORIZONTAL
2	326.82	26.68	-3.26	23.42	46.00	-22.58	Peak	HORIZONTAL
3	472.32	27.24	-0.94	26.30	46.00	-19.70	Peak	HORIZONTAL
4	625.58	27.92	1.77	29.69	46.00	-16.31	Peak	HORIZONTAL
5	720.64	28.55	3.26	31.81	46.00	-14.19	Peak	HORIZONTAL
6	834.13	28.59	5.20	33.79	46.00	-12.21	Peak	HORIZONTAL

Remark:

- 1 emission is 20dB lower, so that emission as measured between 9kHz to 30MHz is not reported
- 2 Measuring frequencies from the lowest internal frequency to the 1GHz.
- 3 Radiated emissions measured in frequency range from 9MHz to 1000MHz were made with an instrument detector setting 9-90kHz/110-490kHz using PK/AV and other Frequency Band using PK/QP
- 4 Measurement result within this frequency range shown “ - ” in the table above means the reading of emissions are attenuated more than 20dB below the permissible limits or the field strength is too small to be measured.

Radiated Spurious Emission Measurement Result (below 1GHz)

Operation Mode	TX MODE	Test Date	2019/12/07
Channel Number	CH High	Test By	Weitin
Temperature	25 °C	Pol	Ver./Hor
Humidity	65 %		

No	Freq MHz	Reading dBuV	Factor dB	Level dBuV/m	Limit dBuV/m	Margin dB	Remark	Pol V/H
1	164.83	28.19	-5.06	23.13	43.50	-20.37	Peak	VERTICAL
2	342.34	26.87	-3.02	23.85	46.00	-22.15	Peak	VERTICAL
3	495.60	28.10	-0.68	27.42	46.00	-18.58	Peak	VERTICAL
4	591.63	29.34	1.34	30.68	46.00	-15.32	Peak	VERTICAL
5	746.83	26.85	3.94	30.79	46.00	-15.21	Peak	VERTICAL
6	837.04	28.10	5.25	33.35	46.00	-12.65	Peak	VERTICAL
1	157.07	27.66	-5.04	22.62	43.50	-20.88	Peak	HORIZONTAL
2	299.66	25.58	-3.82	21.76	46.00	-24.24	Peak	HORIZONTAL
3	497.54	29.49	-0.67	28.82	46.00	-17.18	Peak	HORIZONTAL
4	596.48	28.78	1.44	30.22	46.00	-15.78	Peak	HORIZONTAL
5	704.15	27.28	3.17	30.45	46.00	-15.55	Peak	HORIZONTAL
6	756.53	28.18	4.13	32.31	46.00	-13.69	Peak	HORIZONTAL

Remark:

- 1 emission is 20dB lower, so that emission as measured between 9kHz to 30MHz is not reported
- 2 Measuring frequencies from the lowest internal frequency to the 1GHz.
- 3 Radiated emissions measured in frequency range from 9MHz to 1000MHz were made with an instrument detector setting 9-90kHz/110-490kHz using PK/AV and other Frequency Band using PK/QP
- 4 Measurement result within this frequency range shown “ - ” in the table above means the reading of emissions are attenuated more than 20dB below the permissible limits or the field strength is too small to be measured.

Radiated Spurious Emission Measurement Result (below 1GHz)

(Band UNII-3, 802.11ac VHT80 mode)

Operation Mode	TX MODE	Test Date	2019/12/07
Channel Number	CH Low	Test By	Weitin
Temperature	25 °C	Pol	Ver./Hor
Humidity	65 %		

No	Freq MHz	Reading dBuV	Factor dB	Level dBuV/m	Limit dBuV/m	Margin dB	Remark	Pol V/H
1	157.07	27.31	-5.04	22.27	43.50	-21.23	Peak	VERTICAL
2	323.91	27.67	-3.33	24.34	46.00	-21.66	Peak	VERTICAL
3	465.53	27.65	-0.94	26.71	46.00	-19.29	Peak	VERTICAL
4	521.79	28.34	0.11	28.45	46.00	-17.55	Peak	VERTICAL
5	597.45	28.72	1.47	30.19	46.00	-15.81	Peak	VERTICAL
6	817.64	27.71	4.96	32.67	46.00	-13.33	Peak	VERTICAL
1	166.77	27.09	-5.11	21.98	43.50	-21.52	Peak	HORIZONTAL
2	312.27	26.01	-3.61	22.40	46.00	-23.60	Peak	HORIZONTAL
3	424.79	26.68	-1.56	25.12	46.00	-20.88	Peak	HORIZONTAL
4	543.13	27.35	0.41	27.76	46.00	-18.24	Peak	HORIZONTAL
5	696.39	27.57	3.07	30.64	46.00	-15.36	Peak	HORIZONTAL
6	835.10	28.09	5.21	33.30	46.00	-12.70	Peak	HORIZONTAL

Remark:

- 1 emission is 20dB lower, so that emission as measured between 9kHz to 30MHz is not reported
- 2 Measuring frequencies from the lowest internal frequency to the 1GHz.
- 3 Radiated emissions measured in frequency range from 9MHz to 1000MHz were made with an instrument detector setting 9-90kHz/110-490kHz using PK/AV and other Frequency Band using PK/QP
- 4 Measurement result within this frequency range shown “ - ” in the table above means the reading of emissions are attenuated more than 20dB below the permissible limits or the field strength is too small to be measured.

Radiated Spurious Emission Measurement Result (above 1GHz)
(Band UNII-1, 802.11a mode)

Operation Mode	TX MODE	Test Date	2019/12/07
Channel Number	CH Low	Test By	Weitin
Temperature	25 °C	Humidity	60 %

No	Freq MHz	Reading dBuV	Factor dB	Level dBuV/m	Limit dBuV/m	Margin dB	Remark	Pol V/H
1	10360.00	41.63	4.02	45.65	68.20	-22.55	Peak	VERTICAL
2	15270.00	45.04	8.48	53.52	68.20	-14.68	Peak	VERTICAL
1	10360.00	41.26	4.02	45.28	68.20	-22.92	Peak	HORIZONTAL
2	14100.00	44.38	9.46	53.84	68.20	-14.36	Peak	HORIZONTAL

Remark:

- 1 Field strength limits for frequency above 1000MHz are based on average limits. However, Peak mode field strength shall not exceed the average limits specified plus 20dB.
- 2 Measurement of data within this frequency range shown “ - ” in the table above means the reading of emissions are attenuated more than 20dB below the permissible limits or the field strength is too small to be measured.

Radiated Spurious Emission Measurement Result (above 1GHz)

Operation Mode	TX MODE	Test Date	2019/12/07
Channel Number	CH Mid	Test By	Weitin
Temperature	25 °C	Humidity	60 %

No	Freq MHz	Reading dBuV	Factor dB	Level dBuV/m	Limit dBuV/m	Margin dB	Remark	Pol V/H
1	10400.00	42.19	4.14	46.33	68.20	-21.87	Peak	VERTICAL
2	14060.00	44.35	9.47	53.82	68.20	-14.38	Peak	VERTICAL
1	10400.00	40.84	4.14	44.98	68.20	-23.22	Peak	HORIZONTAL
2	14240.00	43.84	9.39	53.23	68.20	-14.97	Peak	HORIZONTAL

Remark:

- 1 Field strength limits for frequency above 1000MHz are based on average limits. However, Peak mode field strength shall not exceed the average limits specified plus 20dB.
- 2 Measurement of data within this frequency range shown “ - ” in the table above means the reading of emissions are attenuated more than 20dB below the permissible limits or the field strength is too small to be measured.

Radiated Spurious Emission Measurement Result (above 1GHz)

Operation Mode	TX MODE	Test Date	2019/12/07
Channel Number	CH High	Test By	Weitin
Temperature	25 °C	Humidity	60 %

No	Freq MHz	Reading dBuV	Factor dB	Level dBuV/m	Limit dBuV/m	Margin dB	Remark	Pol V/H
1	10480.00	42.85	4.35	47.20	68.20	-21.00	Peak	VERTICAL
2	14150.00	44.14	9.44	53.58	68.20	-14.62	Peak	VERTICAL
1	10480.00	41.91	4.35	46.26	68.20	-21.94	Peak	HORIZONTAL
2	14130.00	43.68	9.43	53.11	68.20	-15.09	Peak	HORIZONTAL

Remark:

- 1 Field strength limits for frequency above 1000MHz are based on average limits. However, Peak mode field strength shall not exceed the average limits specified plus 20dB.
- 2 Measurement of data within this frequency range shown “ - ” in the table above means the reading of emissions are attenuated more than 20dB below the permissible limits or the field strength is too small to be measured.

Radiated Spurious Emission Measurement Result (above 1GHz)

(Band UNII-1, 802.11 n HT20 mode)

Operation Mode	TX MODE	Test Date	2019/12/07
Channel Number	CH Low	Test By	Weitin
Temperature	25 °C	Humidity	60 %

No	Freq MHz	Reading dBuV	Factor dB	Level dBuV/m	Limit dBuV/m	Margin dB	Remark	Pol V/H
1	10360.00	40.62	4.02	44.64	68.20	-23.56	Peak	VERTICAL
2	14190.00	43.96	9.41	53.37	68.20	-14.83	Peak	VERTICAL
1	10360.00	40.69	4.02	44.71	68.20	-23.49	Peak	HORIZONTAL
2	14150.00	44.65	9.44	54.09	68.20	-14.11	Peak	HORIZONTAL

Remark:

- 1 Field strength limits for frequency above 1000MHz are based on average limits. However, Peak mode field strength shall not exceed the average limits specified plus 20dB.
- 2 Measurement of data within this frequency range shown “ - ” in the table above means the reading of emissions are attenuated more than 20dB below the permissible limits or the field strength is too small to be measured.

Radiated Spurious Emission Measurement Result (above 1GHz)

Operation Mode	TX MODE	Test Date	2019/12/07
Channel Number	CH Mid	Test By	Weitin
Temperature	25 °C	Humidity	60 %

No	Freq MHz	Reading dBuV	Factor dB	Level dBuV/m	Limit dBuV/m	Margin dB	Remark	Pol V/H
1	10400.00	41.42	4.14	45.56	68.20	-22.64	Peak	VERTICAL
2	14150.00	43.07	9.44	52.51	68.20	-15.69	Peak	VERTICAL
1	10400.00	41.81	4.14	45.95	68.20	-22.25	Peak	HORIZONTAL
2	14100.00	43.96	9.46	53.42	68.20	-14.78	Peak	HORIZONTAL

Remark:

- 1 Field strength limits for frequency above 1000MHz are based on average limits. However, Peak mode field strength shall not exceed the average limits specified plus 20dB.
- 2 Measurement of data within this frequency range shown “ - ” in the table above means the reading of emissions are attenuated more than 20dB below the permissible limits or the field strength is too small to be measured.

Radiated Spurious Emission Measurement Result (above 1GHz)

Operation Mode	TX MODE	Test Date	2019/12/07
Channel Number	CH High	Test By	Weitin
Temperature	25 °C	Humidity	60 %

No	Freq MHz	Reading dBuV	Factor dB	Level dBuV/m	Limit dBuV/m	Margin dB	Remark	Pol V/H
1	10480.00	41.76	4.35	46.11	68.20	-22.09	Peak	VERTICAL
2	14340.00	44.16	9.33	53.49	68.20	-14.71	Peak	VERTICAL
1	10480.00	40.84	4.35	45.19	68.20	-23.01	Peak	HORIZONTAL
2	14300.00	44.00	9.35	53.35	68.20	-14.85	Peak	HORIZONTAL

Remark:

- 1 Field strength limits for frequency above 1000MHz are based on average limits. However, Peak mode field strength shall not exceed the average limits specified plus 20dB.
- 2 Measurement of data within this frequency range shown “ - ” in the table above means the reading of emissions are attenuated more than 20dB below the permissible limits or the field strength is too small to be measured.

Radiated Spurious Emission Measurement Result (above 1GHz)

(Band UNII-1, 802.11n HT40 mode)

Operation Mode	TX MODE	Test Date	2019/12/07
Channel Number	CH Low	Test By	Weitin
Temperature	25 °C	Humidity	60 %

No	Freq MHz	Reading dBuV	Factor dB	Level dBuV/m	Limit dBuV/m	Margin dB	Remark	Pol V/H
1	10380.00	41.04	4.08	45.12	68.20	-23.08	Peak	VERTICAL
2	14970.00	43.43	9.18	52.61	68.20	-15.59	Peak	VERTICAL
1	10380.00	40.83	4.08	44.91	68.20	-23.29	Peak	HORIZONTAL
2	14710.00	43.55	9.22	52.77	68.20	-15.43	Peak	HORIZONTAL

Remark:

- 1 Field strength limits for frequency above 1000MHz are based on average limits. However, Peak mode field strength shall not exceed the average limits specified plus 20dB.
- 2 Measurement of data within this frequency range shown “ - ” in the table above means the reading of emissions are attenuated more than 20dB below the permissible limits or the field strength is too small to be measured.

Radiated Spurious Emission Measurement Result (above 1GHz)

Operation Mode	TX MODE	Test Date	2019/12/07
Channel Number	CH High	Test By	Weitin
Temperature	25 °C	Humidity	60 %

No	Freq MHz	Reading dBuV	Factor dB	Level dBuV/m	Limit dBuV/m	Margin dB	Remark	Pol V/H
1	10460.00	42.03	4.29	46.32	68.20	-21.88	Peak	VERTICAL
2	14930.00	44.98	9.18	54.16	68.20	-14.04	Peak	VERTICAL
1	10460.00	42.70	4.29	46.99	68.20	-21.21	Peak	HORIZONTAL
2	14150.00	43.25	9.44	52.69	68.20	-15.51	Peak	HORIZONTAL

Remark:

- 1 Field strength limits for frequency above 1000MHz are based on average limits. However, Peak mode field strength shall not exceed the average limits specified plus 20dB.
- 2 Measurement of data within this frequency range shown “ - ” in the table above means the reading of emissions are attenuated more than 20dB below the permissible limits or the field strength is too small to be measured.

Radiated Spurious Emission Measurement Result (above 1GHz)

(Band UNII-1, 802.11ac VHT80 mode)

Operation Mode	TX MODE	Test Date	2019/12/07
Channel Number	CH Low	Test By	Weitin
Temperature	25 °C	Humidity	60 %

No	Freq MHz	Reading dBuV	Factor dB	Level dBuV/m	Limit dBuV/m	Margin dB	Remark	Pol V/H
1	10420.00	41.81	4.20	46.01	68.20	-22.19	Peak	VERTICAL
2	14100.00	43.62	9.46	53.08	68.20	-15.12	Peak	VERTICAL
1	10420.00	43.64	4.20	47.84	68.20	-20.36	Peak	HORIZONTAL
2	14280.00	43.89	9.36	53.25	68.20	-14.95	Peak	HORIZONTAL

Remark:

- 1 Field strength limits for frequency above 1000MHz are based on average limits. However, Peak mode field strength shall not exceed the average limits specified plus 20dB.
- 2 Measurement of data within this frequency range shown “ - ” in the table above means the reading of emissions are attenuated more than 20dB below the permissible limits or the field strength is too small to be measured.

Radiated Spurious Emission Measurement Result (above 1GHz)

(Band UNII-3, 802.11 a mode)

Operation Mode	TX MODE	Test Date	2019/12/07
Channel Number	CH Low	Test By	Weitin
Temperature	25 °C	Humidity	60 %

No	Freq MHz	Reading dBuV	Factor dB	Level dBuV/m	Limit dBuV/m	Margin dB	Remark	Pol V/H
1	11490.00	39.70	6.40	46.10	74.00	-27.90	Peak	VERTICAL
2	14380.00	43.45	9.31	52.76	68.20	-15.44	Peak	VERTICAL
1	11490.00	39.92	6.40	46.32	74.00	-27.68	Peak	HORIZONTAL
2	14100.00	44.77	9.46	54.23	68.20	-13.97	Peak	HORIZONTAL

Remark:

- 1 Field strength limits for frequency above 1000MHz are based on average limits. However, Peak mode field strength shall not exceed the average limits specified plus 20dB.
- 2 Measurement of data within this frequency range shown “ - ” in the table above means the reading of emissions are attenuated more than 20dB below the permissible limits or the field strength is too small to be measured.

Radiated Spurious Emission Measurement Result (above 1GHz)

(Band UNII-3, 802.11 a mode)

Operation Mode	TX MODE	Test Date	2019/12/07
Channel Number	CH Mid	Test By	Weitin
Temperature	25 °C	Humidity	60 %

No	Freq MHz	Reading dBuV	Factor dB	Level dBuV/m	Limit dBuV/m	Margin dB	Remark	Pol V/H
1	11570.00	39.17	6.42	45.59	74.00	-28.41	Peak	VERTICAL
2	13610.00	44.17	8.60	52.77	68.20	-15.43	Peak	VERTICAL
1	11570.00	39.58	6.42	46.00	74.00	-28.00	Peak	HORIZONTAL
2	13670.00	44.66	8.75	53.41	68.20	-14.79	Peak	HORIZONTAL

Remark:

- 1 Field strength limits for frequency above 1000MHz are based on average limits. However, Peak mode field strength shall not exceed the average limits specified plus 20dB.
- 2 Measurement of data within this frequency range shown “ - ” in the table above means the reading of emissions are attenuated more than 20dB below the permissible limits or the field strength is too small to be measured.

Radiated Spurious Emission Measurement Result (above 1GHz)

(Band UNII-3, 802.11 a mode)

Operation Mode	TX MODE	Test Date	2019/12/07
Channel Number	CH High	Test By	Weitin
Temperature	25 °C	Humidity	60 %

No	Freq MHz	Reading dBuV	Factor dB	Level dBuV/m	Limit dBuV/m	Margin dB	Remark	Pol V/H
1	11650.00	42.60	6.43	49.03	74.00	-24.97	Peak	VERTICAL
2	14150.00	44.24	9.44	53.68	68.20	-14.52	Peak	VERTICAL
1	11650.00	39.49	6.43	45.92	74.00	-28.08	Peak	HORIZONTAL
2	14320.00	43.66	9.34	53.00	68.20	-15.20	Peak	HORIZONTAL

Remark:

- 1 Field strength limits for frequency above 1000MHz are based on average limits. However, Peak mode field strength shall not exceed the average limits specified plus 20dB.
- 2 Measurement of data within this frequency range shown “ - ” in the table above means the reading of emissions are attenuated more than 20dB below the permissible limits or the field strength is too small to be measured.

Radiated Spurious Emission Measurement Result (above 1GHz)

(Band UNII-3, 802.11n HT20 mode)

Operation Mode	TX MODE	Test Date	2019/12/07
Channel Number	CH Low	Test By	Weitin
Temperature	25 °C	Humidity	60 %

No	Freq MHz	Reading dBuV	Factor dB	Level dBuV/m	Limit dBuV/m	Margin dB	Remark	Pol V/H
1	11490.00	41.35	6.40	47.75	74.00	-26.25	Peak	VERTICAL
2	14150.00	44.45	9.44	53.89	68.20	-14.31	Peak	VERTICAL
1	11490.00	40.38	6.40	46.78	74.00	-27.22	Peak	HORIZONTAL
2	14150.00	43.70	9.44	53.14	68.20	-15.06	Peak	HORIZONTAL

Remark:

- 1 Field strength limits for frequency above 1000MHz are based on average limits. However, Peak mode field strength shall not exceed the average limits specified plus 20dB.
- 2 Measurement of data within this frequency range shown “ - ” in the table above means the reading of emissions are attenuated more than 20dB below the permissible limits or the field strength is too small to be measured.

Radiated Spurious Emission Measurement Result (above 1GHz)

(Band UNII-3, 802.11n HT20 mode)

Operation Mode	TX MODE	Test Date	2019/12/07
Channel Number	CH Mid	Test By	Weitin
Temperature	25 °C	Humidity	60 %

No	Freq MHz	Reading dBuV	Factor dB	Level dBuV/m	Limit dBuV/m	Margin dB	Remark	Pol V/H
1	11570.00	39.61	6.42	46.03	74.00	-27.97	Peak	VERTICAL
2	14100.00	44.53	9.46	53.99	68.20	-14.21	Peak	VERTICAL
1	11570.00	40.64	6.42	47.06	74.00	-26.94	Peak	HORIZONTAL
2	14100.00	43.35	9.46	52.81	68.20	-15.39	Peak	HORIZONTAL

Remark:

- 1 Field strength limits for frequency above 1000MHz are based on average limits. However, Peak mode field strength shall not exceed the average limits specified plus 20dB.
- 2 Measurement of data within this frequency range shown “ - ” in the table above means the reading of emissions are attenuated more than 20dB below the permissible limits or the field strength is too small to be measured.

Radiated Spurious Emission Measurement Result (above 1GHz)

Operation Mode	TX MODE	Test Date	2019/12/07
Channel Number	CH High	Test By	Weitin
Temperature	25 °C	Humidity	60 %

No	Freq MHz	Reading dBuV	Factor dB	Level dBuV/m	Limit dBuV/m	Margin dB	Remark	Pol V/H
1	11650.00	40.06	6.43	46.49	74.00	-27.51	Peak	VERTICAL
2	13930.00	44.05	9.35	53.40	68.20	-14.80	Peak	VERTICAL
1	11650.00	39.52	6.43	45.95	74.00	-28.05	Peak	HORIZONTAL
2	14180.00	44.08	9.41	53.49	68.20	-14.71	Peak	HORIZONTAL

Remark:

- 1 Field strength limits for frequency above 1000MHz are based on average limits. However, Peak mode field strength shall not exceed the average limits specified plus 20dB.
- 2 Measurement of data within this frequency range shown “ - ” in the table above means the reading of emissions are attenuated more than 20dB below the permissible limits or the field strength is too small to be measured.

Radiated Spurious Emission Measurement Result (above 1GHz)

(Band UNII-3, 802.11n HT40 mode)

Operation Mode	TX MODE	Test Date	2019/12/07
Channel Number	CH Low	Test By	Weitin
Temperature	25 °C	Humidity	60 %

No	Freq MHz	Reading dBuV	Factor dB	Level dBuV/m	Limit dBuV/m	Margin dB	Remark	Pol V/H
1	11510.00	40.70	6.41	47.11	74.00	-26.89	Peak	VERTICAL
2	14100.00	43.56	9.46	53.02	68.20	-15.18	Peak	VERTICAL
1	11510.00	39.21	6.41	45.62	74.00	-28.38	Peak	HORIZONTAL
2	14170.00	43.71	9.42	53.13	68.20	-15.07	Peak	HORIZONTAL

Remark:

- 1 Field strength limits for frequency above 1000MHz are based on average limits. However, Peak mode field strength shall not exceed the average limits specified plus 20dB.
- 2 Measurement of data within this frequency range shown “ - ” in the table above means the reading of emissions are attenuated more than 20dB below the permissible limits or the field strength is too small to be measured.

Radiated Spurious Emission Measurement Result (above 1GHz)

Operation Mode	TX MODE	Test Date	2019/12/07
Channel Number	CH High	Test By	Weitin
Temperature	25 °C	Humidity	60 %

No	Freq MHz	Reading dBuV	Factor dB	Level dBuV/m	Limit dBuV/m	Margin dB	Remark	Pol V/H
1	11590.00	38.70	6.42	45.12	74.00	-28.88	Peak	VERTICAL
2	14170.00	43.66	9.42	53.08	68.20	-15.12	Peak	VERTICAL
1	11590.00	39.96	6.42	46.38	74.00	-27.62	Peak	HORIZONTAL
2	14160.00	45.92	9.43	55.35	68.20	-12.85	Peak	HORIZONTAL

Remark:

- 1 Field strength limits for frequency above 1000MHz are based on average limits. However, Peak mode field strength shall not exceed the average limits specified plus 20dB.
- 2 Measurement of data within this frequency range shown “ - ” in the table above means the reading of emissions are attenuated more than 20dB below the permissible limits or the field strength is too small to be measured.

Radiated Spurious Emission Measurement Result (above 1GHz)
(Band UNII-3, 802.11ac VHT80 mode)

Operation Mode	TX MODE	Test Date	2019/12/07
Channel Number	CH Low	Test By	Weitin
Temperature	25 °C	Humidity	60 %

No	Freq MHz	Reading dBuV	Factor dB	Level dBuV/m	Limit dBuV/m	Margin dB	Remark	Pol V/H
1	11550.00	40.06	6.41	46.47	74.00	-27.53	Peak	VERTICAL
2	14150.00	43.61	9.44	53.05	68.20	-15.15	Peak	VERTICAL
1	11550.00	40.58	6.41	46.99	74.00	-27.01	Peak	HORIZONTAL
2	14190.00	44.08	9.41	53.49	68.20	-14.71	Peak	HORIZONTAL

Remark:

- 1 Field strength limits for frequency above 1000MHz are based on average limits. However, Peak mode field strength shall not exceed the average limits specified plus 20dB.
- 2 Measurement of data within this frequency range shown “ - ” in the table above means the reading of emissions are attenuated more than 20dB below the permissible limits or the field strength is too small to be measured.

Band Edges test (Band UNII-1, 802.11a mode) -Radiated

Operation Mode	TX CH Low Ch	Test Date	2019/12/07
Channel Number	5180 MHz	Test By	Weitin
Temperature	25 °C	Humidity	65 %

No	Freq MHz	Reading dBuV	Factor dB	Level dBuV/m	Limit dBuV/m	Margin dB	Remark	Pol V/H
1	5150.00	7.81	39.04	46.85	54.00	-7.15	Average	VERTICAL
2	5150.00	26.22	39.04	65.26	74.00	-8.74	Peak	VERTICAL
1	5150.00	6.30	39.04	45.34	54.00	-8.66	Average	HORIZONTAL
2	5150.00	25.95	39.04	64.99	74.00	-9.01	Peak	HORIZONTAL

Operation Mode	TX CH High Ch	Test Date	2019/12/07
Channel Number	5240MHz	Test By	Weitin
Temperature	25 °C	Humidity	65 %

No	Freq MHz	Reading dBuV	Factor dB	Level dBuV/m	Limit dBuV/m	Margin dB	Remark	Pol V/H
1	5350.00	5.44	39.26	44.70	54.00	-9.30	Average	VERTICAL
2	5350.00	25.45	39.26	64.71	74.00	-9.29	Peak	VERTICAL
1	5350.00	4.77	39.26	44.03	54.00	-9.97	Average	HORIZONTAL
2	5350.00	24.49	39.26	63.75	74.00	-10.25	Peak	HORIZONTAL

Remark:

- 1 Measuring frequencies from the lowest internal frequency to the 10th of fundamental frequency
- 2 Field strength limits for frequency above 1000MHz are based on average limits. However, Peak mode field strength shall not exceed the average limits specified plus 20dB.
- 3 Measurement of data within this frequency range shown “ - ” in the table above means the reading of emissions are attenuated more than 20dB below the permissible limits or the field strength is too small to be measured.

Band Edges test (Band UNII-1, 802.11n HT20 mode) -Radiated

Operation Mode	TX CH Low	Test Date	2019/12/07
Channel Number	5180 MHz	Test By	Weitin
Temperature	25 °C	Humidity	65 %

No	Freq MHz	Reading dBuV	Factor dB	Level dBuV/m	Limit dBuV/m	Margin dB	Remark	Pol V/H
1	5150.00	6.97	39.04	46.01	54.00	-7.99	Average	VERTICAL
2	5150.00	26.56	39.04	65.60	74.00	-8.40	Peak	VERTICAL
1	5150.00	5.70	39.04	44.74	54.00	-9.26	Average	HORIZONTAL
2	5150.00	25.56	39.04	64.60	74.00	-9.40	Peak	HORIZONTAL

Operation Mode	TX CH High	Test Date	2019/12/07
Channel Number	5240MHz	Test By	Weitin
Temperature	25 °C	Humidity	65 %

No	Freq MHz	Reading dBuV	Factor dB	Level dBuV/m	Limit dBuV/m	Margin dB	Remark	Pol V/H
1	5350.00	5.96	39.26	45.22	54.00	-8.78	Average	VERTICAL
2	5350.00	25.66	39.26	64.92	74.00	-9.08	Peak	VERTICAL
1	5350.00	5.13	39.26	44.39	54.00	-9.61	Average	HORIZONTAL
2	5350.00	25.06	39.26	64.32	74.00	-9.68	Peak	HORIZONTAL

Remark:

- 1 Measuring frequencies from the lowest internal frequency to the 10th of fundamental frequency
- 2 Field strength limits for frequency above 1000MHz are based on average limits. However, Peak mode field strength shall not exceed the average limits specified plus 20dB.
- 3 Measurement of data within this frequency range shown “ - ” in the table above means the reading of emissions are attenuated more than 20dB below the permissible limits or the field strength is too small to be measured.

Band Edges test (Band UNII-1, 802.11n HT40 mode) -Radiated

Operation Mode	TX CH Low	Test Date	2019/12/07
Channel Number	5190 MHz	Test By	Weitin
Temperature	25 °C	Humidity	65 %

No	Freq MHz	Reading dBuV	Factor dB	Level dBuV/m	Limit dBuV/m	Margin dB	Remark	Pol V/H
1	5150.00	6.97	39.04	46.01	54.00	-7.99	Average	VERTICAL
2	5150.00	26.35	39.04	65.39	74.00	-8.61	Peak	VERTICAL
1	5150.00	6.06	39.04	45.10	54.00	-8.90	Average	HORIZONTAL
2	5150.00	26.04	39.04	65.08	74.00	-8.92	Peak	HORIZONTAL

Operation Mode	TX CH High	Test Date	2019/12/07
Channel Number	5230MHz	Test By	Weitin
Temperature	25 °C	Humidity	65 %

No	Freq MHz	Reading dBuV	Factor dB	Level dBuV/m	Limit dBuV/m	Margin dB	Remark	Pol V/H
1	5350.00	6.43	39.26	45.69	54.00	-8.31	Average	VERTICAL
2	5350.00	25.13	39.26	64.39	74.00	-9.61	Peak	VERTICAL
1	5350.00	5.34	39.26	44.60	54.00	-9.40	Average	HORIZONTAL
2	5350.00	25.52	39.26	64.78	74.00	-9.22	Peak	HORIZONTAL

Remark:

- 1 Measuring frequencies from the lowest internal frequency to the 10th of fundamental frequency
- 2 Field strength limits for frequency above 1000MHz are based on average limits. However, Peak mode field strength shall not exceed the average limits specified plus 20dB.
- 3 Measurement of data within this frequency range shown “ - ” in the table above means the reading of emissions are attenuated more than 20dB below the permissible limits or the field strength is too small to be measured.

Band Edges test (Band UNII-1, 802.11ac VHT20 mode) -Radiated

Operation Mode	TX CH Low	Test Date	2019/12/07
Channel Number	5180 MHz	Test By	Weitin
Temperature	25 °C	Humidity	65 %

No	Freq MHz	Reading dBuV	Factor dB	Level dBuV/m	Limit dBuV/m	Margin dB	Remark	Pol V/H
1	5150.00	25.84	39.04	64.88	74.00	-9.12	Peak	VERTICAL
1	5150.00	25.48	39.04	64.52	74.00	-9.48	Peak	HORIZONTAL

Operation Mode	TX CH High	Test Date	2019/12/07
Channel Number	5240MHz	Test By	Weitin
Temperature	25 °C	Humidity	65 %

No	Freq MHz	Reading dBuV	Factor dB	Level dBuV/m	Limit dBuV/m	Margin dB	Remark	Pol V/H
1	5350.00	27.05	39.26	66.31	74.00	-7.69	Peak	VERTICAL
1	5350.00	24.88	39.26	64.14	74.00	-9.86	Peak	HORIZONTAL

Remark:

- 1 Measuring frequencies from the lowest internal frequency to the 10th of fundamental frequency
- 2 Field strength limits for frequency above 1000MHz are based on average limits. However, Peak mode field strength shall not exceed the average limits specified plus 20dB.
- 3 Measurement of data within this frequency range shown “ - ” in the table above means the reading of emissions are attenuated more than 20dB below the permissible limits or the field strength is too small to be measured.

Band Edges test (Band UNII-1, 802.11ac VHT40 mode) -Radiated

Operation Mode	TX CH Low	Test Date	2019/12/07
Channel Number	5190 MHz	Test By	Weitin
Temperature	25 °C	Humidity	65 %

No	Freq MHz	Reading dBuV	Factor dB	Level dBuV/m	Limit dBuV/m	Margin dB	Remark	Pol V/H
1	5150.00	25.84	39.04	64.88	74.00	-9.12	Peak	VERTICAL
1	5150.00	25.48	39.04	64.52	74.00	-9.48	Peak	HORIZONTAL

Operation Mode	TX CH High	Test Date	2019/12/07
Channel Number	5230MHz	Test By	Weitin
Temperature	25 °C	Humidity	65 %

No	Freq MHz	Reading dBuV	Factor dB	Level dBuV/m	Limit dBuV/m	Margin dB	Remark	Pol V/H
1	5350.00	27.05	39.26	66.31	74.00	-7.69	Peak	VERTICAL
1	5350.00	24.88	39.26	64.14	74.00	-9.86	Peak	HORIZONTAL

Remark:

- 1 Measuring frequencies from the lowest internal frequency to the 10th of fundamental frequency
- 2 Field strength limits for frequency above 1000MHz are based on average limits. However, Peak mode field strength shall not exceed the average limits specified plus 20dB.
- 3 Measurement of data within this frequency range shown “ - ” in the table above means the reading of emissions are attenuated more than 20dB below the permissible limits or the field strength is too small to be measured.

Band Edges test (Band UNII-1, 802.11ac VHT80 mode) -Radiated

Operation Mode	TX CH Low	Test Date	2019/12/07
Channel Number	5210 MHz	Test By	Weitin
Temperature	25 °C	Humidity	65 %

No	Freq MHz	Reading dBuV	Factor dB	Level dBuV/m	Limit dBuV/m	Margin dB	Remark	Pol V/H
1	5150.00	7.72	39.04	46.76	54.00	-7.24	Average	VERTICAL
2	5150.00	27.10	39.04	66.14	74.00	-7.86	Peak	VERTICAL
1	5150.00	7.06	39.04	46.10	54.00	-7.90	Average	HORIZONTAL
2	5150.00	26.99	39.04	66.03	74.00	-7.97	Peak	HORIZONTAL

Operation Mode	TX CH High	Test Date	2019/12/07
Channel Number	5210 MHz	Test By	Weitin
Temperature	25 °C	Humidity	65 %

No	Freq MHz	Reading dBuV	Factor dB	Level dBuV/m	Limit dBuV/m	Margin dB	Remark	Pol V/H
1	5350.00	6.65	39.26	45.91	54.00	-8.09	Average	VERTICAL
2	5350.00	26.13	39.26	65.39	74.00	-8.61	Peak	VERTICAL
1	5350.00	5.01	39.26	44.27	54.00	-9.73	Average	HORIZONTAL
2	5350.00	24.87	39.26	64.13	74.00	-9.87	Peak	HORIZONTAL

Remark:

- 1 Measuring frequencies from the lowest internal frequency to the 10th of fundamental frequency
- 2 Field strength limits for frequency above 1000MHz are based on average limits. However, Peak mode field strength shall not exceed the average limits specified plus 20dB.
- 3 Measurement of data within this frequency range shown “ - ” in the table above means the reading of emissions are attenuated more than 20dB below the permissible limits or the field strength is too small to be measured.

Band Edges test (Band UNII-3, 802.11a mode) –Radiated

Operation Mode TX CH Low
 Channel Number 5745 MHz
 Temperature 25 °C

Test Date 2019/12/07
 Test By Weitin
 Humidity 65 %

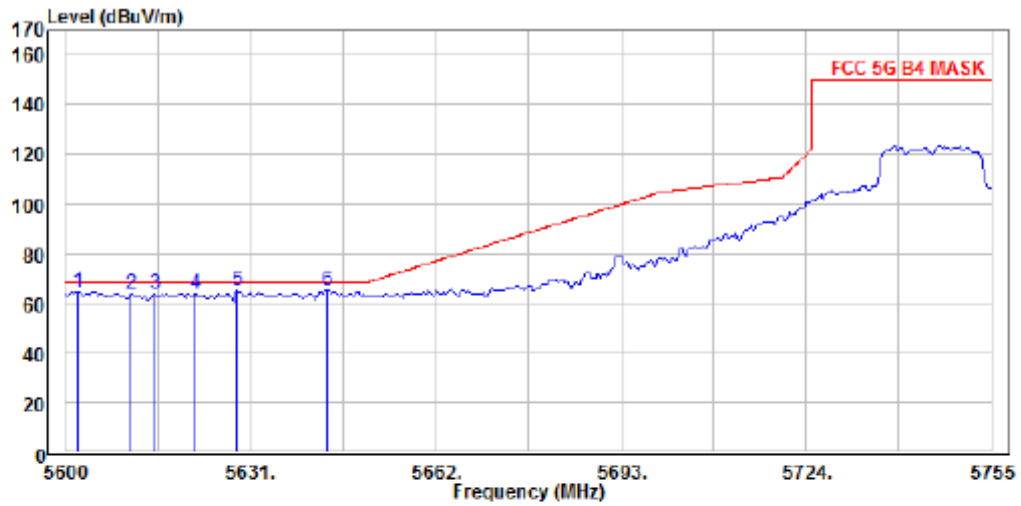

Condition: FCC 5G B4 MASK 3m factor\966 9128D V 1-18G.csv Vertical
 : RBW:1000kHz VBW:1000kHz SWT:Auto DET:Positive
 EUT : 19LR269(Wistron FG-6XF)
 Mode : 5G Mask B4 802.11a Low Ch#21
 Note :

		Read		Limit	Over	
	Freq	Level	Factor	Level	Line	Limit Pol/Phase
	MHz	dBuV	dB/m	dBuV/m	dBuV/m	dB
1	5602.022	61.32	3.39	64.71	68.20	-3.49 Vertical
2	5611.007	60.59	3.42	64.01	68.20	-4.19 Vertical
3	5615.051	60.52	3.43	63.95	68.20	-4.25 Vertical
4	5621.790	60.84	3.45	64.29	68.20	-3.91 Vertical
5	5628.753	61.67	3.46	65.13	68.20	-3.07 Vertical
6 PP	5643.804	61.99	3.50	65.49	68.20	-2.71 Vertical

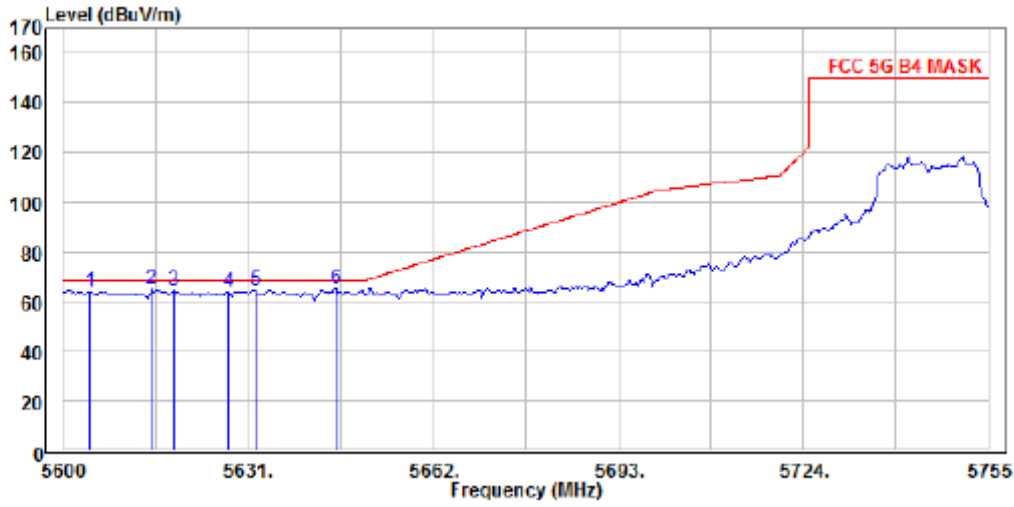

Condition: FCC 5G B4 MASK 3m factor\966 9120D H 1-18G.csv Horizontal
 : RBW:1000kHz VBW:1000kHz SWT:Auto DET:Positive
 EUT : 19LR269(Wistron FG-6XF)
 Mode : 5G Mask B4 802.11a Low Ch#21
 Note :

	Read Freq	Read Level	Read Factor	Read Level	Limit Line	Over Limit	Pol/Phase
	MHz	dBuV	dB/m	dBuV/m	dBuV/m	dB	
1	5604.493	60.76	3.40	64.16	68.20	-4.04	Horizontal
2 PP	5614.826	61.95	3.43	65.38	68.20	-2.82	Horizontal
3	5618.420	60.90	3.43	64.33	68.20	-3.87	Horizontal
4	5627.630	60.71	3.46	64.17	68.20	-4.03	Horizontal
5	5632.123	61.15	3.47	64.62	68.20	-3.58	Horizontal
6	5645.602	61.79	3.51	65.30	68.20	-2.90	Horizontal

Operation Mode TX CH High
 Channel Number 5825MHz
 Temperature 25 °C

Test Date 2019/12/07
 Test By Weitin
 Humidity 65 %

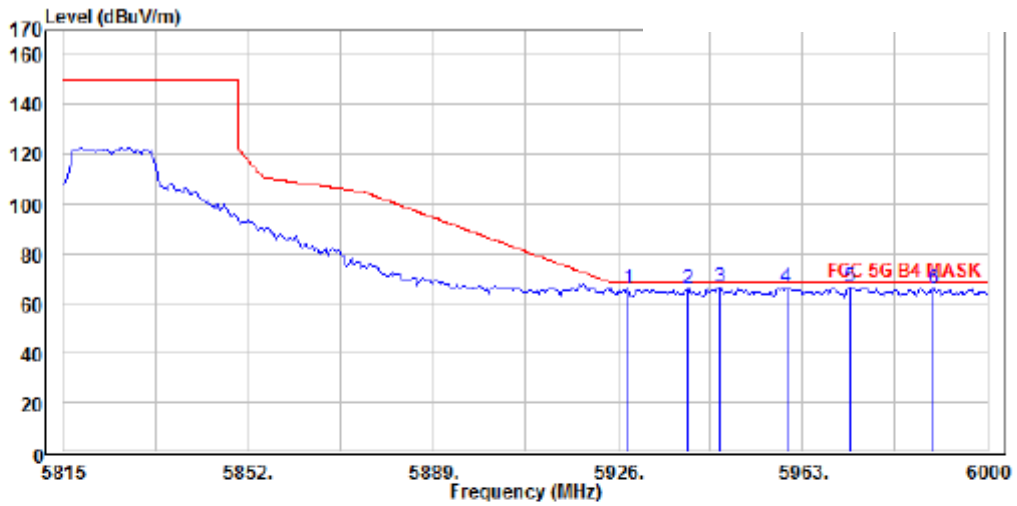

Condition: FCC 5G B4 MASK 3m factor\966 9120D V 1-18G.csv Vertical
 : RBW:1000kHz VBW:1000kHz SWT:Auto DET:Positive
 EUT : 19LR269(Wistron FG-6XF)
 Mode : 5G Mask B4 802.11a High Ch#21
 Note :

	Read Freq	Read Level	Read Factor	Limit Level	Limit Line	Over Limit	Pol/Phase
	MHz	dBuV	dB/m	dBuV/m	dBuV/m	dB	
1	5928.145	61.78	4.23	66.01	68.20	-2.19	Vertical
2	5939.942	61.94	4.27	66.21	68.20	-1.99	Vertical
3	5946.377	62.34	4.28	66.62	68.20	-1.58	Vertical
4 PP	5959.783	62.38	4.31	66.69	68.20	-1.51	Vertical
5	5972.384	62.25	4.35	66.60	68.20	-1.60	Vertical
6	5989.275	61.63	4.39	66.02	68.20	-2.18	Vertical

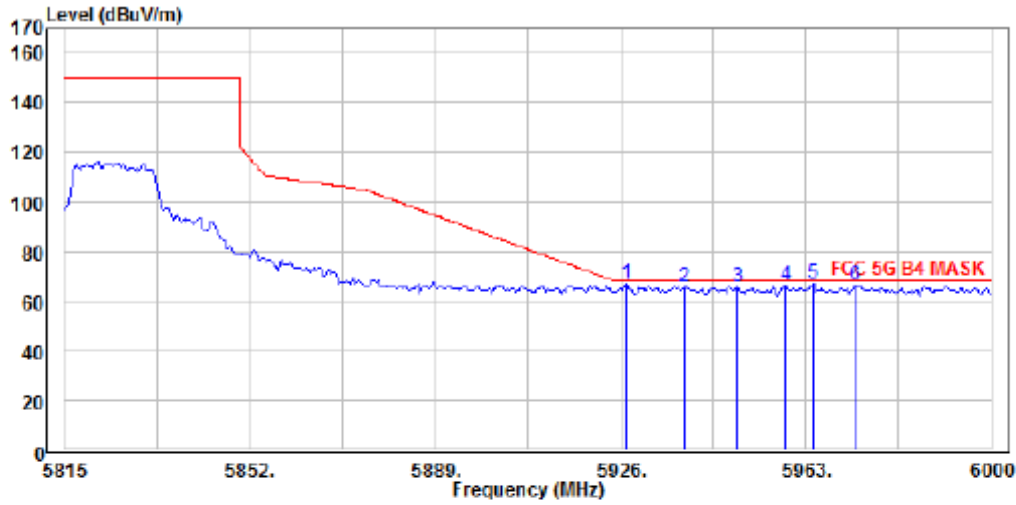

Condition: FCC 5G B4 MASK 3m factor\966 9120D H 1-18G.csv Horizontal
 : RBW:1000kHz VBW:1000kHz SWT:Auto DET:Positive
 EUT : 19LR269(Wistron FG-6XF)
 Mode : 5G Mask B4 802.11a High Ch#21
 Note :

	Read Freq	Read Level	Factor	Level	Limit	Over	Pol/Phase
	MHz	dBuV	dB/m	dBuV/m	dBuV/m	dB	
1	5927.872	62.73	4.23	66.96	68.20	-1.24	Horizontal
2	5938.602	61.82	4.26	66.08	68.20	-2.12	Horizontal
3	5949.326	61.55	4.28	65.83	68.20	-2.37	Horizontal
4	5958.978	62.06	4.31	66.37	68.20	-1.83	Horizontal
5	5964.341	62.84	4.33	67.17	68.20	-1.03	Horizontal
6	5972.920	62.34	4.35	66.69	68.20	-1.51	Horizontal

Band Edges test (Band UNII-3, 802.11n HT20 mode) –Radiated

Operation Mode TX CH Low
 Channel Number 5745 MHz
 Temperature 25 °C

Test Date 2019/12/07
 Test By Weitin
 Humidity 65 %

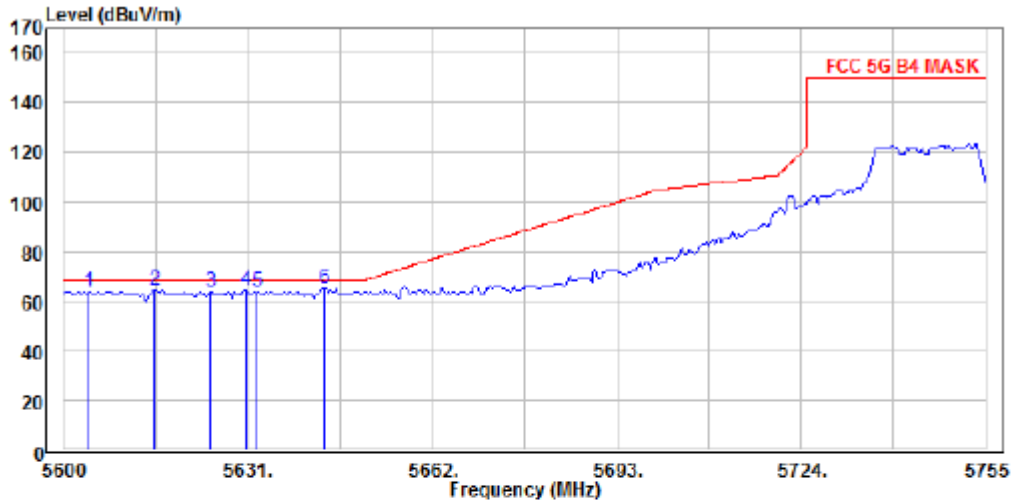

Condition: FCC 5G B4 MASK 3m factor\966 9120D V 1-18G.csv Vertical
 : RBW:1000kHz VBW:1000kHz SWT:Auto DET:Positive
 EUT : 19LR269(Wistron FG-6XF)
 Mode : 5G Mask B4 802.11HT20 Low Ch#21
 Note :

	Read		Limit	Over		
Freq	Level	Factor	Level	Line	Limit	Pol/Phase
MHz	dBuV	dB/m	dBuV/m	dBuV/m	dB	
1	5604.268	60.86	3.40	64.26	68.20	-3.94 Vertical
2	5615.275	61.32	3.43	64.75	68.20	-3.45 Vertical
3	5624.710	60.47	3.46	63.93	68.20	-4.27 Vertical
4	5630.551	61.12	3.47	64.59	68.20	-3.61 Vertical
5	5632.572	60.72	3.47	64.19	68.20	-4.01 Vertical
6 PP	5643.804	61.98	3.50	65.48	68.20	-2.72 Vertical

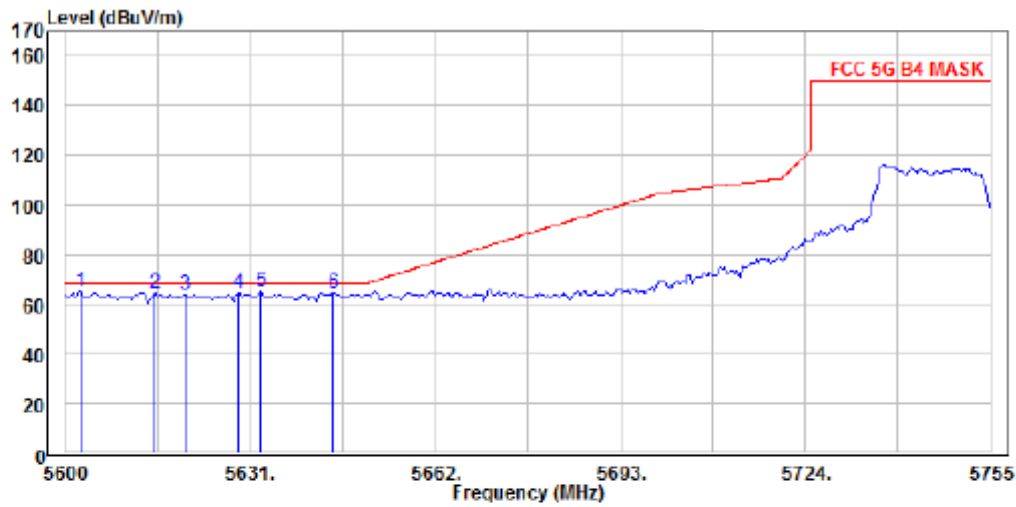

Condition: FCC 5G B4 MASK 3m factor\966 9120D H 1-18G.csv Horizontal
 : RBW:1000kHz VBW:1000kHz SWT:Auto DET:Positive
 EUT : 19LR269(Wistron FG-6XF)
 Mode : 5G Mask B4 802.11HT20 Low Ch#21
 Note :

		Read		Limit	Over	
	Freq	Level	Factor	Level	Line	Limit
	MHz	dBuV	dB/m	dBuV/m	dBuV/m	dB
1	5602.471	62.01	3.39	65.40	68.20	-2.80
2	5615.051	61.50	3.43	64.93	68.20	-3.27
3	5619.993	60.85	3.44	64.29	68.20	-3.91
4	5628.978	61.19	3.47	64.66	68.20	-3.54
5	5632.797	61.64	3.47	65.11	68.20	-3.09
6	5644.928	61.14	3.51	64.65	68.20	-3.55

Operation Mode TX CH High
 Channel Number 5825MHz
 Temperature 25 °C

Test Date 2019/12/07
 Test By Weitin
 Humidity 65 %

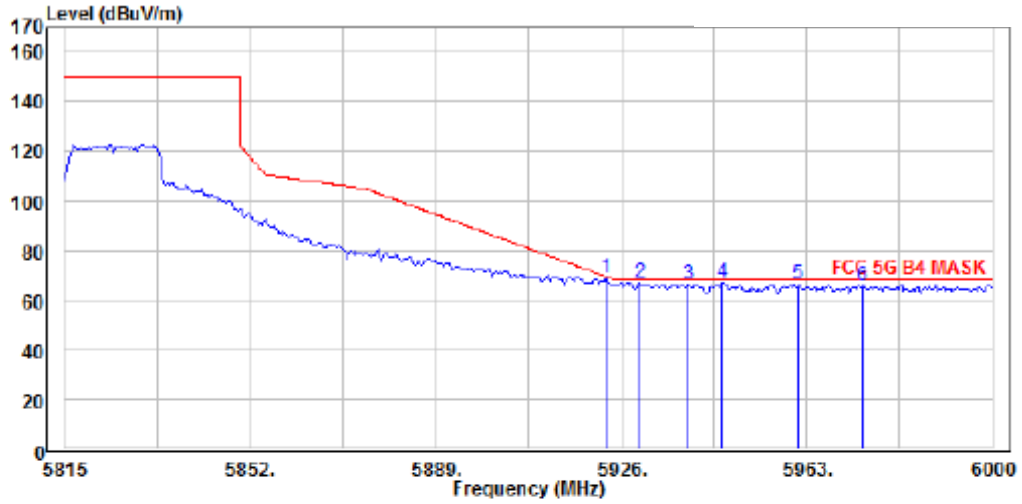

Condition: FCC 5G B4 MASK 3m factor\966 9128D V 1-18G.csv Vertical
 : RBW:1000kHz VBW:1000kHz SWT:Auto DET:Positive
 EUT : 19LR269(Wistron FG-6XF)
 Mode : 5G Mask B4 802.11HT20 High Ch#21
 Note :

	Read		Limit	Over		
Freq	Level	Factor	Level	Line	Limit	Pol/Phase
MHz	dBuV	dB/m	dBuV/m	dBuV/m	dB	
1 PP 5923.051	65.08	4.22	69.30	69.64	-0.34	Vertical
2 5929.753	62.88	4.24	67.12	68.20	-1.08	Vertical
3 5939.406	62.36	4.26	66.62	68.20	-1.58	Vertical
4 5946.109	62.86	4.28	67.14	68.20	-1.06	Vertical
5 5961.391	62.39	4.32	66.71	68.20	-1.49	Vertical
6 5974.261	61.81	4.35	66.16	68.20	-2.04	Vertical

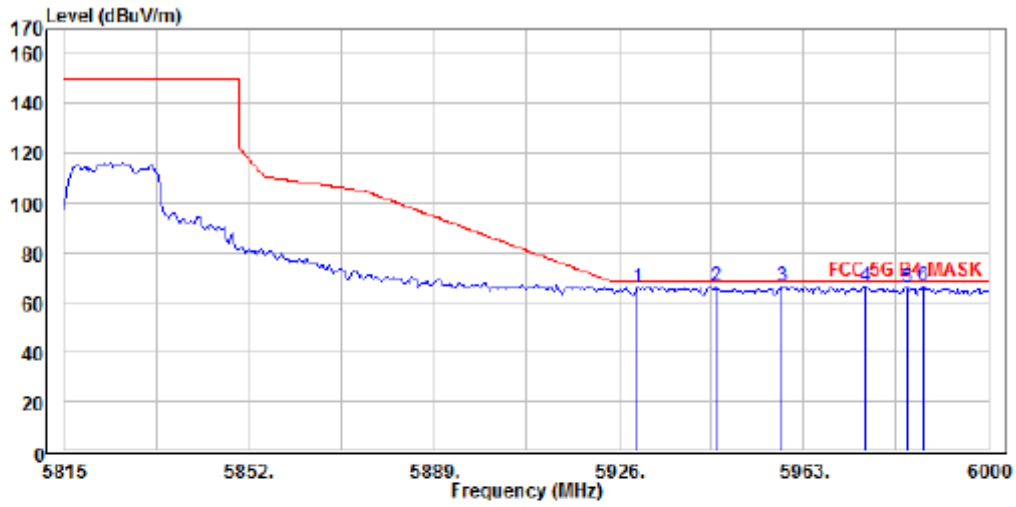

Condition: FCC 5G B4 MASK 3m factor\966 9120D H 1-18G.csv Horizontal
 : RBW:1000kHz VBW:1000kHz SWT:Auto DET:Positive
 EUT : 19LR269(Wistron FG-6XF)
 Mode : 5G Mask B4 802.11HT20 High Ch#21
 Note :

		Read		Limit		Over	
	Freq	Level	Factor	Level	Line	Limit	Pol/Phase
	MHz	dBuV	dB/m	dBuV/m	dBuV/m	dB	
1	5929.753	61.98	4.24	66.22	68.20	-1.98	Horizontal
2	5945.572	62.48	4.28	66.76	68.20	-1.44	Horizontal
3	5958.710	62.20	4.31	66.51	68.20	-1.69	Horizontal
4	5975.333	62.13	4.35	66.48	68.20	-1.72	Horizontal
5	5983.645	61.84	4.38	66.22	68.20	-1.98	Horizontal
6	5987.130	62.11	4.39	66.50	68.20	-1.70	Horizontal

Band Edges test (Band UNII-3, 802.11n HT40 mode) –Radiated

Operation Mode TX CH Low
 Channel Number 5755 MHz
 Temperature 25 °C

Test Date 2019/12/07
 Test By Weitin
 Humidity 65 %

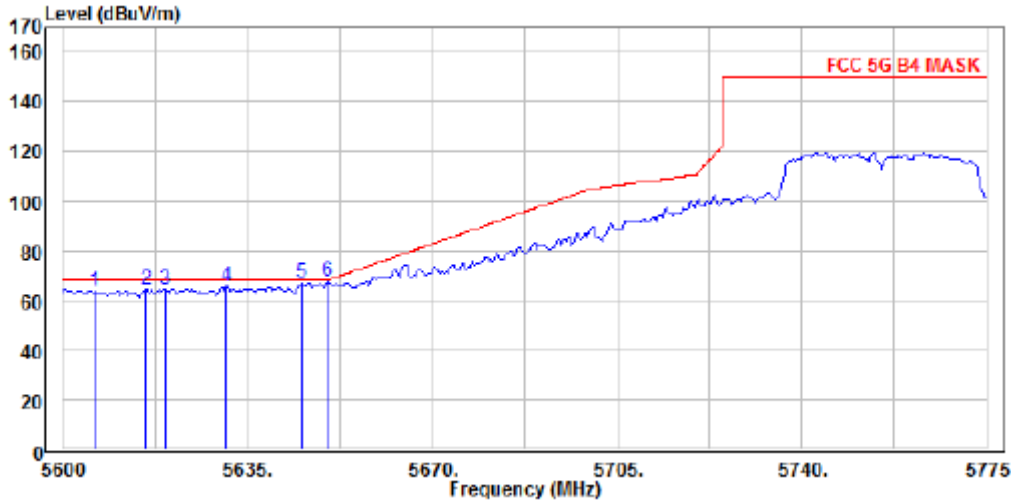

Condition: FCC 5G B4 MASK 3m factor\966 9120D V 1-18G.csv Vertical
 : RBW:1000kHz VBW:1000kHz SWT:Auto DET:Positive
 EUT : 19LR269(Wistron FG-6XF)
 Mode : 5G Mask B4 802.11HT40 Low Ch#20
 Note :

	Read		Limit	Over		
Freq	Level	Factor	Level	Line	Limit	Pol/Phase
MHz	dBuV	dB/m	dBuV/m	dBuV/m	dB	
1	5605.833	60.74	3.40	64.14	68.20	-4.06 Vertical
2	5615.725	61.44	3.43	64.87	68.20	-3.33 Vertical
3	5619.275	61.40	3.44	64.84	68.20	-3.36 Vertical
4	5630.942	62.31	3.47	65.78	68.20	-2.42 Vertical
5	5645.145	63.50	3.51	67.01	68.20	-1.19 Vertical
6 PP	5650.217	64.63	3.53	68.16	68.36	-0.20 Vertical

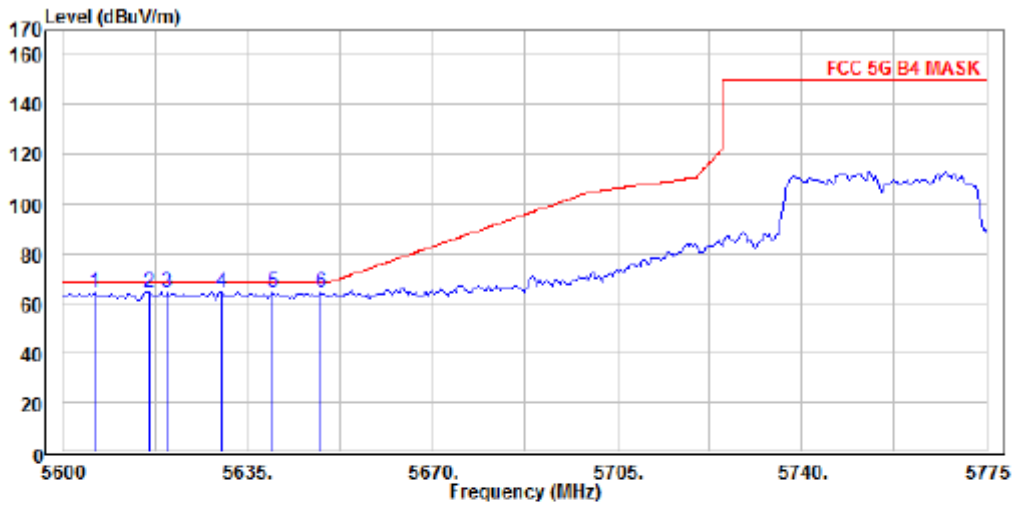

Condition: FCC 5G B4 MASK 3m factor\966 9120D H 1-18G.csv Horizontal
 : RBW:1000kHz VBW:1000kHz SWT:Auto DET:Positive
 EUT : 19LR269(Wistron FG-6XF)
 Mode : 5G Mask B4 802.11HT40 Low Ch#20
 Note :

	Read		Limit	Over		
	Freq	Level	Factor	Level	Line	Limit Pol/Phase
	MHz	dBuV	dB/m	dBuV/m	dBuV/m	dB
1	5606.887	61.39	3.40	64.79	68.20	-3.41 Horizontal
2	5616.232	61.09	3.43	64.52	68.20	-3.68 Horizontal
3	5619.783	61.01	3.44	64.45	68.20	-3.75 Horizontal
4	5629.928	61.18	3.47	64.65	68.20	-3.55 Horizontal
5	5639.819	60.84	3.50	64.34	68.20	-3.86 Horizontal
6	5648.949	60.94	3.51	64.45	68.20	-3.75 Horizontal

Operation Mode TX CH High
 Channel Number 5795MHz
 Temperature 25 °C

Test Date 2019/12/07
 Test By Weitin
 Humidity 65 %

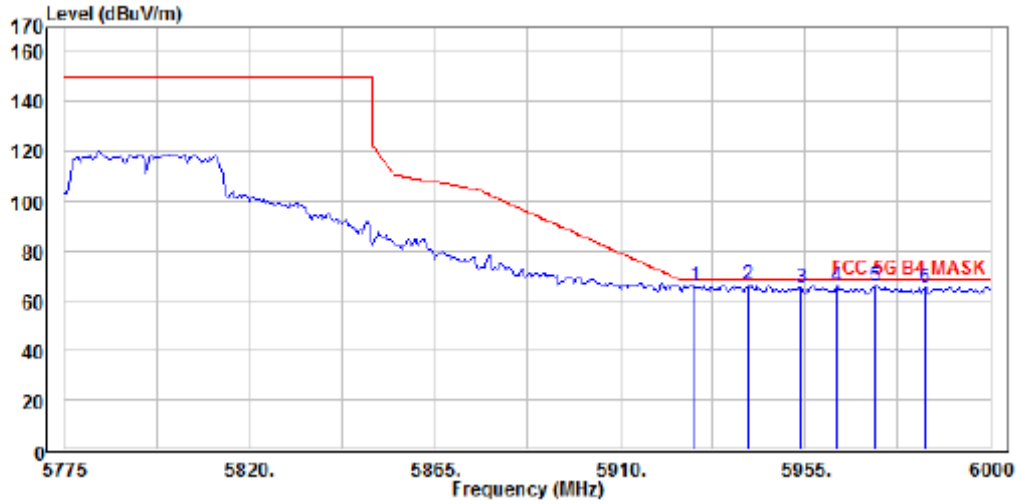

Condition: FCC 5G B4 MASK 3m factor\966 9128D V 1-18G.csv Vertical
 : RBW:1000kHz VBW:1000kHz SWT:Auto DET:Positive
 EUT : 19LR269(Wistron FG-6XF)
 Mode : 5G Mask B4 802.11HT40 High Ch#20
 Note :

	Freq	Read Level	Factor	Level	Limit	Over	Pol/Phase
	MHz	dBuV	dB/m	dBuV/m	dBuV/m	dB	
1	5928.261	61.96	4.23	66.19	68.20	-2.01	Vertical
2 PP	5941.304	62.42	4.27	66.69	68.20	-1.51	Vertical
3	5954.022	60.98	4.30	65.28	68.20	-2.92	Vertical
4	5962.500	61.41	4.32	65.73	68.20	-2.47	Vertical
5	5971.957	61.79	4.35	66.14	68.20	-2.06	Vertical
6	5984.022	61.19	4.38	65.57	68.20	-2.63	Vertical

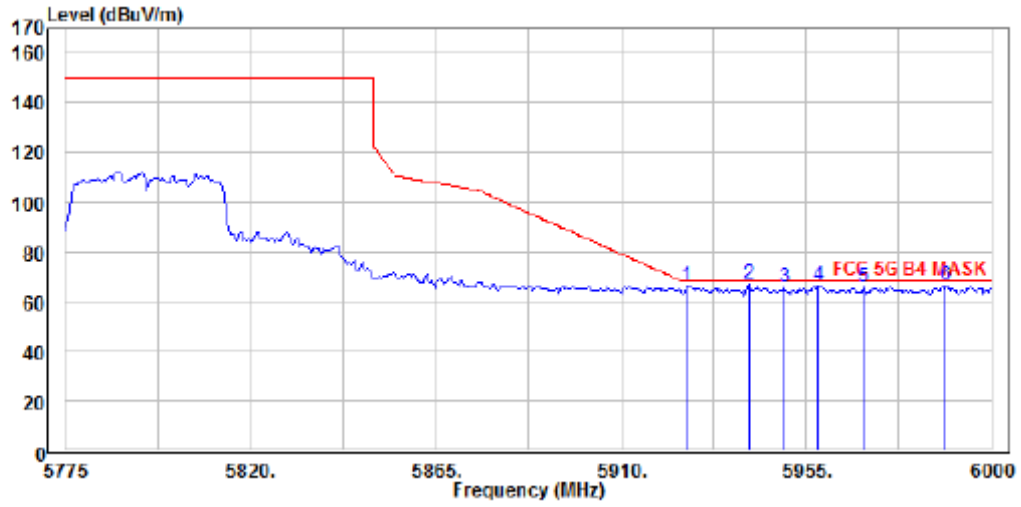

Condition: FCC 5G B4 MASK 3m factor\966 9120D H 1-18G.csv Horizontal
 : RBW:1000kHz VBW:1000kHz SWT:Auto DET:Positive
 EUT : 19LR269(Wistron FG-6XF)
 Mode : 5G Mask B4 802.11HT40 High Ch#20
 Note :

		Read		Limit		Over	
	Freq	Level	Factor	Level	Line	Limit	Pol/Phase
	MHz	dBuV	dB/m	dBuV/m	dBuV/m	dB	
1	5925.978	62.16	4.23	66.39	68.20	-1.81	Horizontal
2	PP 5940.978	62.76	4.27	67.03	68.20	-1.17	Horizontal
3	5949.783	61.43	4.28	65.71	68.20	-2.49	Horizontal
4	5957.935	62.46	4.31	66.77	68.20	-1.43	Horizontal
5	5969.022	61.86	4.34	66.20	68.20	-2.00	Horizontal
6	5988.913	62.25	4.39	66.64	68.20	-1.56	Horizontal

Band Edges test (Band UNII-3, 802.11ac VHT20 mode) –Radiated

Operation Mode TX CH Low
 Channel Number 5745 MHz
 Temperature 25 °C

Test Date 2019/12/07
 Test By Weitin
 Humidity 65 %

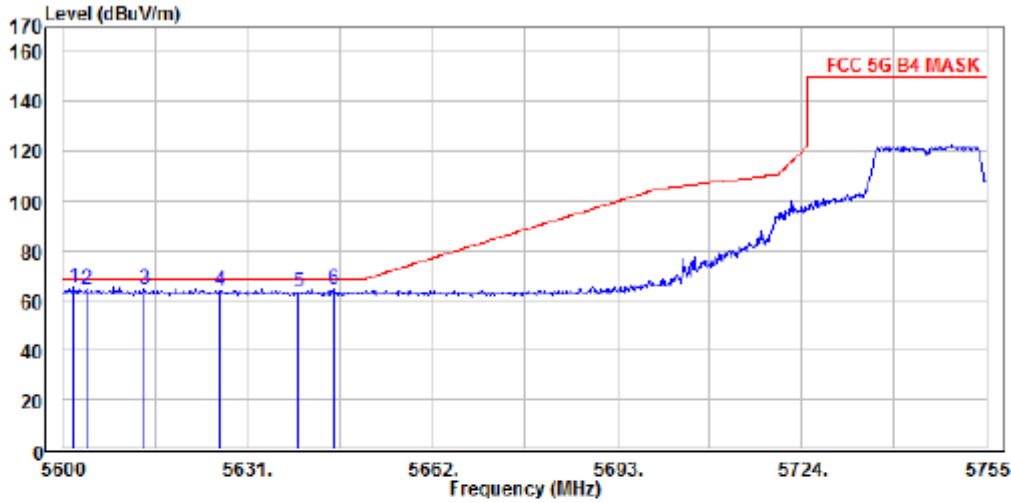

Condition: FCC 5G B4 MASK 3m factor\966 9120D V 1-18G.csv Vertical
 : RBW:1000kHz VBW:1000kHz SWT:Auto DET:Positive
 EUT : 19LR269(Wistron FG-6XF)
 Mode : 5G Mask B4 802.11VHT20 Low Ch #19
 Note :

	Read		Limit	Over	
Freq	Level	Factor	Level	Limit	Pol/Phase
MHz	dBuV	dB/m	dBuV/m	dBuV/m	dB
1 PP 5601.868	61.88	3.39	65.27	68.20	-2.93 Vertical
2 5603.875	61.01	3.40	64.41	68.20	-3.79 Vertical
3 5613.640	61.51	3.43	64.94	68.20	-3.26 Vertical
4 5626.350	60.74	3.46	64.20	68.20	-4.00 Vertical
5 5639.370	60.01	3.49	63.50	68.20	-4.70 Vertical
6 5645.415	60.94	3.51	64.45	68.20	-3.75 Vertical

Operation Mode TX CH High
 Channel Number 5825 MHz
 Temperature 25 °C

Test Date 2019/12/07
 Test By Weitin
 Humidity 65 %

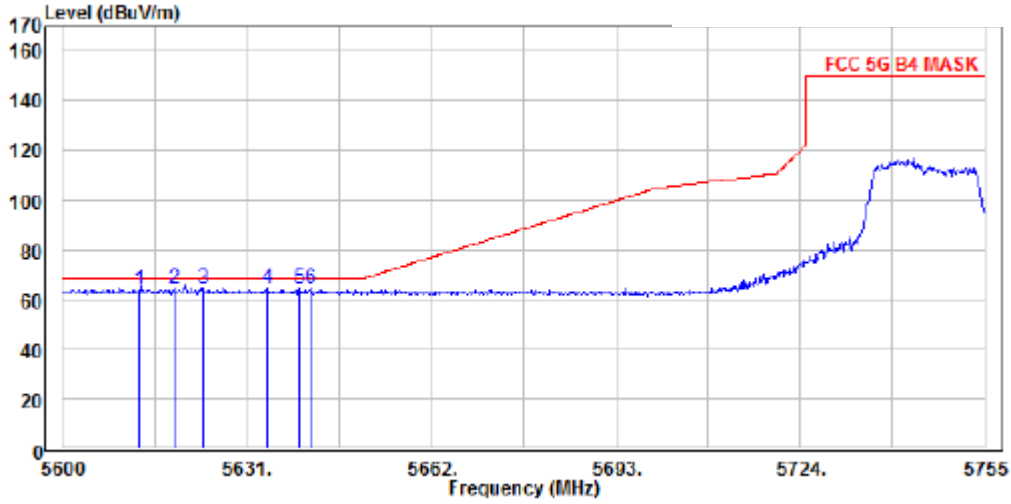

Condition: FCC 5G B4 MASK 3m factor\966 9128D H 1-18G.csv Horizontal
 : RBW:1000kHz VBN:1000kHz SWT:Auto DET:Positive
 EUT : 19LR269(Wistron FG-6XF)
 Mode : 5G Mask B4 802.11VHT20 Low Ch #19
 Note :

	Read Freq	Read Level	Read Factor	Level	Limit	Over	Pol/Phase
	MHz	dBuV	dB/m	dBuV/m	dBuV/m	dB	
1	5612.710	60.67	3.42	64.09	68.20	-4.11	Horizontal
2	5618.755	60.98	3.44	64.42	68.20	-3.78	Horizontal
3	5623.560	61.27	3.45	64.72	68.20	-3.48	Horizontal
4	5634.255	61.03	3.48	64.51	68.20	-3.69	Horizontal
5 PP	5639.680	61.36	3.50	64.86	68.20	-3.34	Horizontal
6	5641.695	60.96	3.50	64.46	68.20	-3.74	Horizontal

Operation Mode TX CH High
 Channel Number 5825MHz
 Temperature 25 °C

Test Date 2019/12/07
 Test By Weitin
 Humidity 65 %

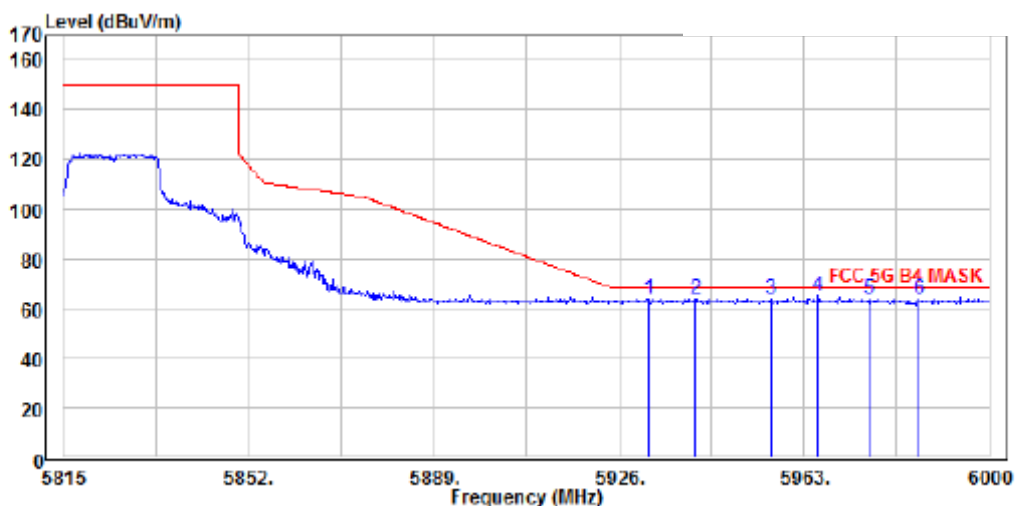

Condition: FCC 5G B4 MASK 3m factor\966 9120D V 1-18G.csv Vertical
 : RBW:1000kHz VBW:1000kHz SWT:Auto DET:Positive
 EUT : 19LR269(Wistron FG-6XF)
 Mode : 5G Mask B4 802.11VHT20 High Ch #19
 Note :

	Read Freq	Read Level	Read Factor	Level	Limit	Over Limit	Pol/Phase
	MHz	dBuV	dB/m	dBuV/m	dBuV/m	dB	
1	5931.920	59.68	4.24	63.92	68.20	-4.28	Vertical
2	5941.170	59.64	4.27	63.91	68.20	-4.29	Vertical
3	5956.340	59.51	4.31	63.82	68.20	-4.38	Vertical
4 PP	5965.775	60.76	4.33	65.09	68.20	-3.11	Vertical
5	5975.950	59.83	4.35	64.18	68.20	-4.02	Vertical
6	5986.125	59.52	4.38	63.90	68.20	-4.30	Vertical

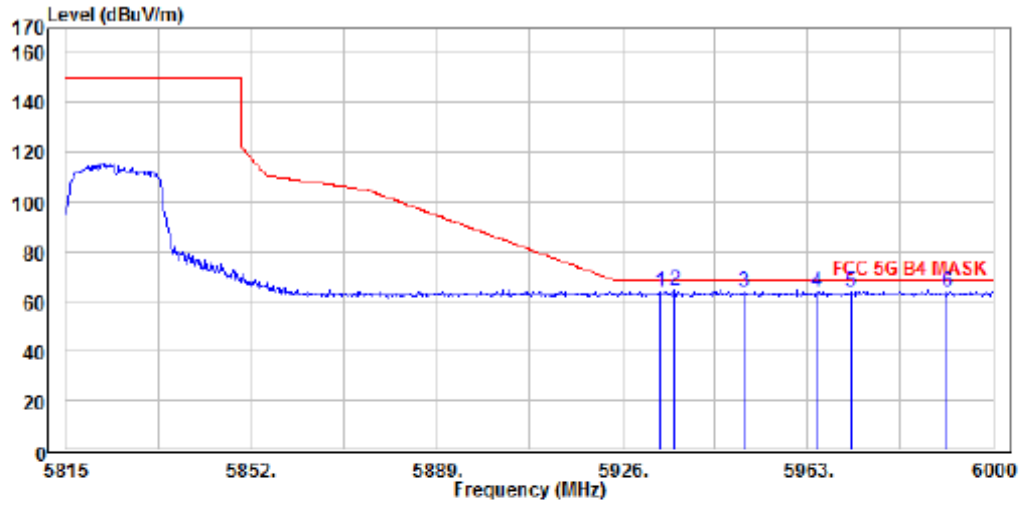

Condition: FCC 5G B4 MASK 3m factor\966 9120D H 1-18G.csv Horizontal
 : RBW:1000kHz VBW:1000kHz SWT:Auto DET:Positive
 EUT : 19LR269(Wistron FG-6XF)
 Mode : 5G Mask B4 802.11VHT20 High Ch #19
 Note :

	Read			Limit	Over	
Freq	Level	Factor	Level	Line	Limit	Pol/Phase
MHz	dBuV	dB/m	dBuV/m	dBuV/m	dB	
1	5933.585	59.62	4.24	63.86	68.20	-4.34 Horizontal
2 PP	5936.545	60.27	4.26	64.53	68.20	-3.67 Horizontal
3	5950.235	59.83	4.30	64.13	68.20	-4.07 Horizontal
4	5964.665	59.47	4.33	63.80	68.20	-4.40 Horizontal
5	5971.695	59.79	4.35	64.14	68.20	-4.06 Horizontal
6	5990.935	59.85	4.39	64.24	68.20	-3.96 Horizontal

Band Edges test (Band UNII-3, 802.11ac VHT40 mode) –Radiated

Operation Mode TX CH Low
 Channel Number 5755 MHz
 Temperature 25 °C

Test Date 2019/12/07
 Test By Weitin
 Humidity 65 %

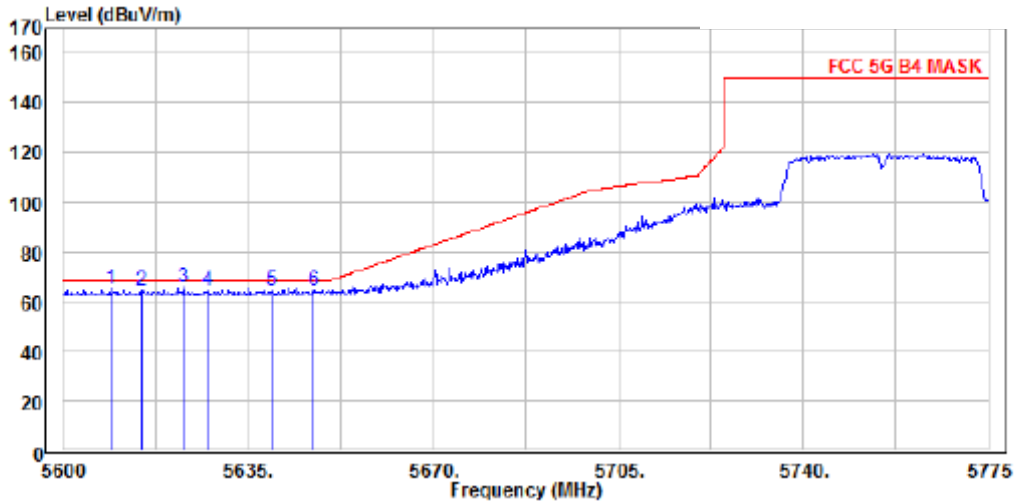

Condition: FCC 5G B4 MASK 3m factor\966 9120D V 1-18G.csv Vertical
 : RBW:1000kHz VBW:1000kHz SWT:Auto DET:Positive
 EUT : 19LR269(Wistron FG-6XF)
 Mode : 5G Mask B4 802.11VHT40 Low Ch #19
 Note :

	Read		Limit	Over		
	Freq	Level	Factor	Level	Line	Limit
	MHz	dBuV	dB/m	dBuV/m	dBuV/m	dB
1	5608.925	61.76	3.42	65.18	68.20	-3.02
2	5614.700	61.12	3.43	64.55	68.20	-3.65
3 PP	5622.750	62.28	3.45	65.73	68.20	-2.47
4	5627.300	61.15	3.46	64.61	68.20	-3.59
5	5639.375	61.11	3.49	64.60	68.20	-3.60
6	5647.425	61.16	3.51	64.67	68.20	-3.53

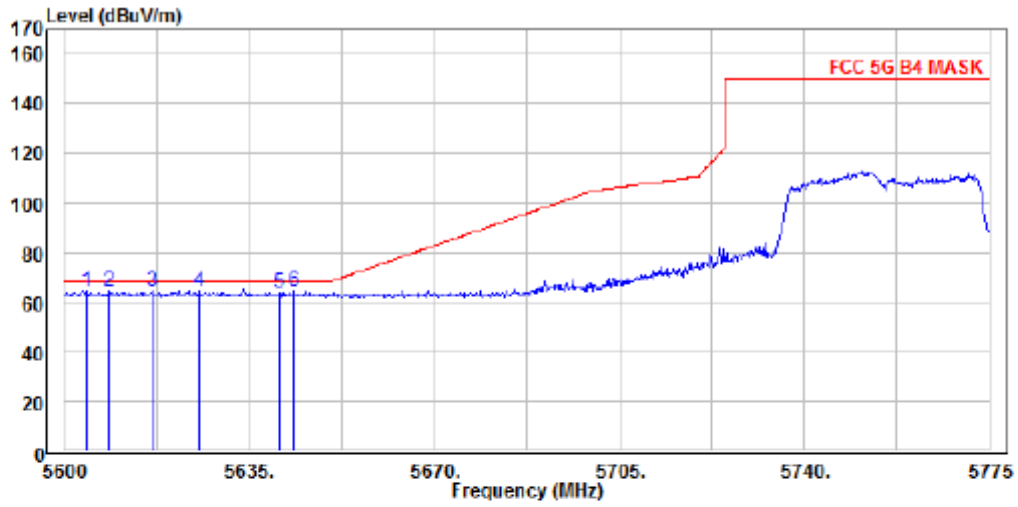

Condition: FCC 5G B4 MASK 3m factor\966 9120D H 1-18G.csv Horizontal
 : RBW:1000kHz VBW:1000kHz SWT:Auto DET:Positive
 EUT : 19LR269(Wistron FG-6XF)
 Mode : 5G Mask B4 802.11VHT40 Low Ch #19
 Note :

	Read Freq	Read Level	Read Factor	Limit Level	Over Limit	Over Limit	Pol/Phase
	MHz	dBuV	dB/m	dBuV/m	dBuV/m	dB	
1	5604.025	61.18	3.40	64.58	68.20	-3.62	Horizontal
2	5608.400	60.98	3.42	64.40	68.20	-3.80	Horizontal
3 PP	5616.625	61.48	3.43	64.91	68.20	-3.29	Horizontal
4	5625.550	61.17	3.46	64.63	68.20	-3.57	Horizontal
5	5640.600	60.70	3.50	64.20	68.20	-4.00	Horizontal
6	5643.400	61.17	3.50	64.67	68.20	-3.53	Horizontal

Operation Mode TX CH High
 Channel Number 5795MHz
 Temperature 25 °C

Test Date 2019/12/07
 Test By Weitin
 Humidity 65 %

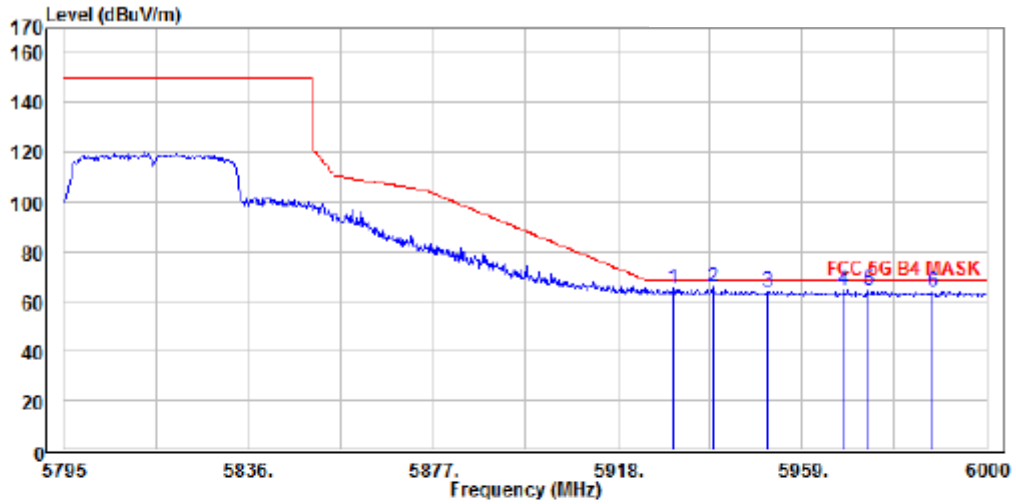

Condition: FCC 5G B4 MASK 3m factor\966 9120D V 1-18G.csv Vertical
 : RBW:1000kHz VBW:1000kHz SWT:Auto DET:Positive
 EUT : 19LR269(Wistron FG-6XF)
 Mode : 5G Mask B4 802.11VHT40 High Ch #19
 Note :

	Read	Limit	Over			
Freq	Level	Factor	Level	Line	Limit	
MHz	dBuV	dB/m	dBuV/m	dBuV/m	dB	
1	5930.300	60.80	4.24	65.04	68.20	-3.16 Vertical
2 PP	5939.115	61.81	4.26	66.07	68.20	-2.13 Vertical
3	5951.415	59.98	4.30	64.28	68.20	-3.92 Vertical
4	5968.225	60.48	4.34	64.82	68.20	-3.38 Vertical
5	5973.965	60.06	4.35	64.41	68.20	-3.79 Vertical
6	5987.905	59.75	4.39	64.14	68.20	-4.06 Vertical

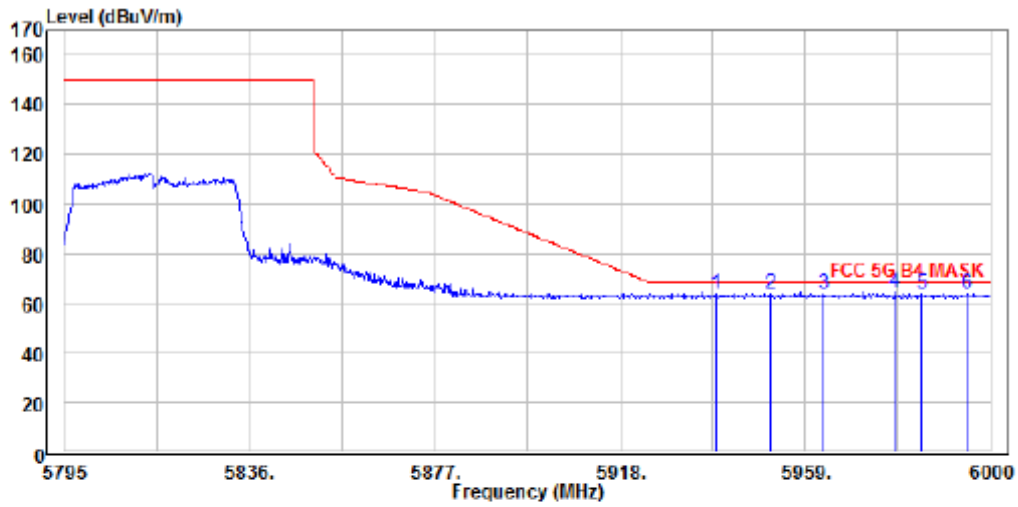

Condition: FCC 5G B4 MASK 3m factor\966 9120D H 1-18G.csv Horizontal
 : RBW:1000kHz VBW:1000kHz SWT:Auto DET:Positive
 EUT : 19LR269(Wistron FG-6XF)
 Mode : 5G Mask B4 802.11VHT40 High Ch #19
 Note :

	Read Freq	Read Level	Read Factor	Limit Level	Over Limit	Pol/Phase
	MHz	dBuV	dB/m	dBuV/m	dBuV/m	dB
1	5939.320	59.76	4.26	64.02	68.20	-4.18 Horizontal
2	5951.415	59.82	4.30	64.12	68.20	-4.08 Horizontal
3	5963.100	59.62	4.32	63.94	68.20	-4.26 Horizontal
4 PP	5978.885	59.96	4.37	64.33	68.20	-3.87 Horizontal
5	5984.830	59.70	4.38	64.08	68.20	-4.12 Horizontal
6	5994.875	59.67	4.41	64.08	68.20	-4.12 Horizontal

Band Edges test (Band UNII-3, 802.11ac VHT80 mode) –Radiated

Operation Mode TX CH Low
 Channel Number 5775 MHz
 Temperature 25 °C

Test Date 2018/12/08
 Test By Weitin
 Humidity 65 %

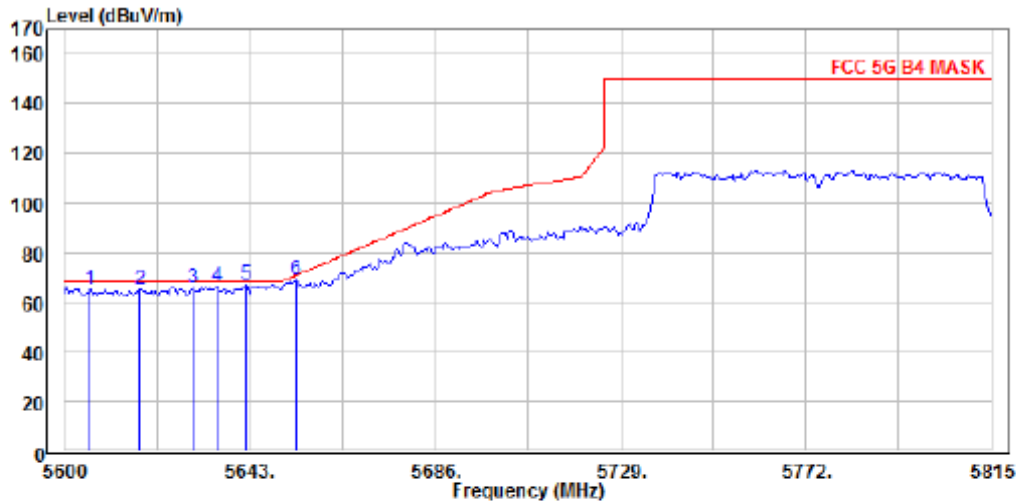

Condition: FCC 5G B4 MASK 3m factor\966 9128D V 1-18G.csv Vertical
 : RBW:1000kHz VBW:1000kHz SWT:Auto DET:Positive
 EUT : 19LR269(Wistron FG-6XF)
 Mode : 5G Mask B4 802.11AC80 #15
 Note :

	Read		Limit	Over		
	Freq	Level	Factor	Level	Line	Limit Pol/Phase
	MHz	dBuV	dB/m	dBuV/m	dBuV/m	dB
1	5605.920	61.68	3.40	65.08	68.20	-3.12 Vertical
2	5617.449	62.10	3.43	65.53	68.20	-2.67 Vertical
3	5629.913	62.69	3.47	66.16	68.20	-2.04 Vertical
4	5635.522	63.01	3.48	66.49	68.20	-1.71 Vertical
5 PP	5642.065	63.78	3.50	67.28	68.20	-0.92 Vertical
6	5653.594	65.43	3.53	68.96	70.87	-1.91 Vertical

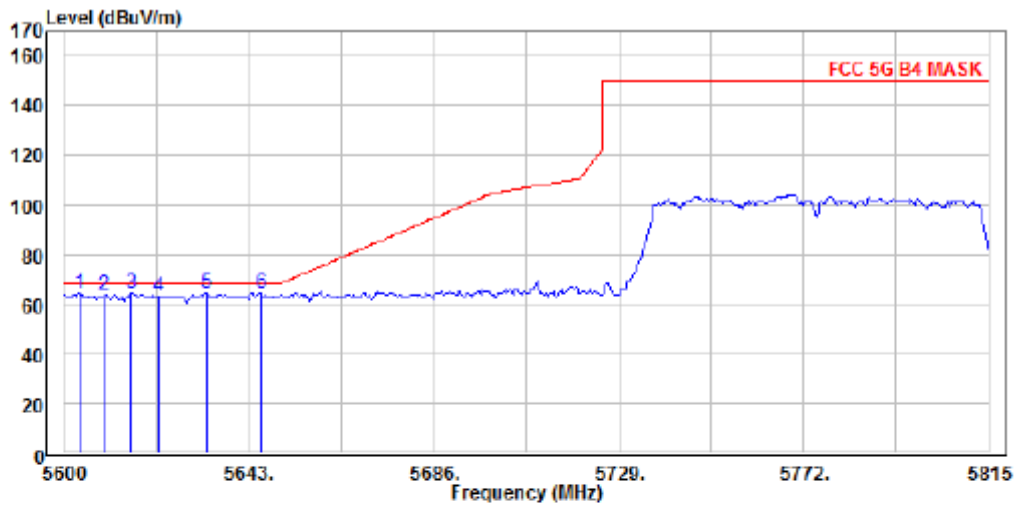

Condition: FCC 5G B4 MASK 3m factor\966 9128D H 1-18G.csv Horizontal
 : RBW:1000kHz VBW:1000kHz SWT:Auto DET:Positive
 EUT : 19LR269(Wistron FG-6XF)
 Mode : 5G Mask B4 802.11AC80 #15
 Note :

	Read			Limit	Over	
	Freq	Level	Factor	Level	Line	Limit Pol/Phase
	MHz	dBUV	dB/m	dBUV/m	dBUV/m	dB
1	5603.428	61.33	3.40	64.73	68.20	-3.47 Horizontal
2	5609.348	60.51	3.42	63.93	68.20	-4.27 Horizontal
3	5615.580	61.04	3.43	64.47	68.20	-3.73 Horizontal
4	5621.812	60.22	3.45	63.67	68.20	-4.53 Horizontal
5 PP	5633.029	61.36	3.47	64.83	68.20	-3.37 Horizontal
6	5645.804	61.21	3.51	64.72	68.20	-3.48 Horizontal

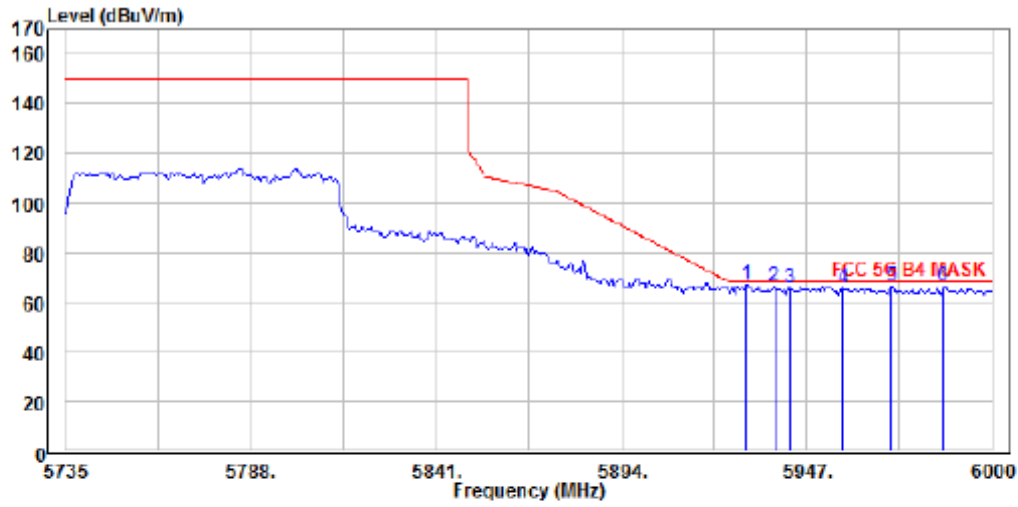

Condition: FCC 5G B4 MASK 3m factor\966 9120D V 1-18G.csv Vertical
 : RBW:1000kHz VBN:1000kHz SWT:Auto DET:Positive
 EUT : 19LR269(Wistron FG-6XF)
 Mode : 5G Mask B4 802.11AC80 #15
 Note :

	Read		Limit	Over		
Freq	Level	Factor	Level	Line	Limit	Pol/Phase
MHz	dBuV	dB/m	dBuV/m	dBuV/m	dB	
1 PP 5929.717	62.72	4.24	66.96	68.20	-1.24	Vertical
2 5937.783	62.01	4.26	66.27	68.20	-1.93	Vertical
3 5942.007	61.92	4.27	66.19	68.20	-2.01	Vertical
4 5957.370	61.32	4.31	65.63	68.20	-2.57	Vertical
5 5971.196	62.18	4.35	66.53	68.20	-1.67	Vertical
6 5986.174	61.97	4.38	66.35	68.20	-1.85	Vertical

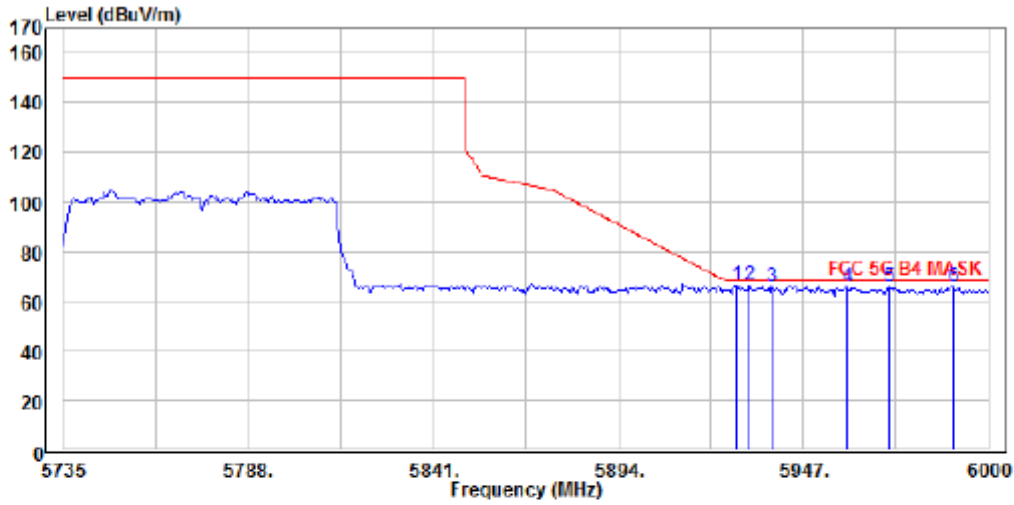

Condition: FCC 5G B4 MASK 3m factor\966 9120D H 1-18G.csv Horizontal
 : RBW:1000kHz VBW:1000kHz SWT:Auto DET:Positive
 EUT : 19LR269(Wistron FG-6XF)
 Mode : 5G Mask B4 802.11AC80 #15
 Note :

	Read		Limit	Over			
	Freq	Level	Factor	Level	Line	Limit	
	MHz	dBuV	dB/m	dBuV/m	dBuV/m	dB	Pol/Phase
1	5927.797	62.29	4.23	66.52	68.20	-1.68	Horizontal
2	5931.638	62.16	4.24	66.40	68.20	-1.80	Horizontal
3	5938.167	61.94	4.26	66.20	68.20	-2.00	Horizontal
4	5959.674	61.63	4.31	65.94	68.20	-2.26	Horizontal
5	5971.580	61.30	4.35	65.65	68.20	-2.55	Horizontal
6	5990.015	61.27	4.39	65.66	68.20	-2.54	Horizontal

10. Transmission in the Absence of Data

10.1. Standard Applicable

According to §15.407(c)

The device shall automatically discontinue transmission in case of either absence of information to transmit or operational failure. These provisions are not intended to preclude the transmission of control or signaling information or the use of repetitive codes used by certain digital technologies to complete frame or burst intervals. Applicants shall include in their application for equipment authorization a description of how this requirement is met.

10.2. Result:

Pass, the device is compliance with 802.11 a/ b/g/n ac standard, the short control signal is appear during no transmission period.

11. Antenna Requirement

11.1. Standard Applicable

According to §15.203, Antenna requirement.

An intentional radiator shall be designed to ensure that no antenna other than that furnished by the responsible party shall be used with the device. The use of a permanently attached antenna or of an antenna that uses a unique coupling to the intentional radiator shall be considered sufficient to comply with the provisions of this Section. The manufacturer may design the unit so that a broken antenna can be replaced by the user, but the use of a standard antenna jack or electrical connector is prohibited. This requirement does not apply to carrier current devices or to devices operated under the provisions of Sections 15.211, 15.213, 15.217, 15.219, or 15.221. Further, this requirement does not apply to intentional radiators that must be professionally installed, such as perimeter protection systems and some field disturbance sensors, or to other intentional radiators which, in accordance with Section 15.31(d), must be measured at the installation site. However, the installer shall be responsible for ensuring that the proper antenna is employed so that the limits in this Part are not exceeded.

11.2. Antenna Connected Construction

The directional gains of antenna used for transmitting is 3.06dBi for Band UNII-1 / 3.58dBi for Band UNII-3, which is revised Dipole antenna and no consideration of replacement by user. Please see EUT photo and antenna spec. for details.