

Submittal Application Report

for
Grant of Certification

Model: RB911G-2HPnD-12S
2412-2462 MHz

Broadband Digital Transmission System
FCC ID: TV7RB911G2HPND
IC: 7442A-911G2HPND

FOR

Mikrotikls SIA

Brivibas gatve 214i
Riga Latvia LV-1039

Test Report Number: 180509
FCC Site Registration: US5305
IC Test Site Registration: 3041A-1

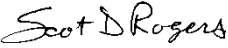
Authorized Signatory: 
Scot D. Rogers

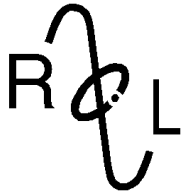

ROGERS LABS, INC.

4405 West 259th Terrace
Louisburg, KS 66053
Phone / Fax (913) 837-3214

Engineering Test Report for
Grant of Certification Application
FOR
Broadband Digital Transmission System
CFR 47, PART 15C - Paragraph 15.247
Industry Canada RSS-247 Issue1
License Exempt Intentional Radiator
For

Mikrotikls SIA

Brivibas gatve 214i
Riga Latvia LV-1039

Broadband Digital Transmission System

Model: RB911G-2HPnD-12S
Frequency Range 2412-2462 MHz
FCC: TV7RB911G2HPND
IC: 7442A-911G2HPND

Test Date: May 9, 2018

Certifying Engineer: *Scot D. Rogers*
Scot D. Rogers
Rogers Labs, Inc.
4405 West 259th Terrace
Louisburg, KS 66053
Telephone/Facsimile: (913) 837-3214

This report shall not be reproduced except in full, without the written approval of the laboratory.
This report must not be used by the client to claim product certification, approval, or
endorsement by NVLAP, NIST, or any agency of the Federal Government.

Rogers Labs, Inc.	Mikrotikls SIA	S/N: 84AD08CAE425, 84AD08300865
4405 W. 259th Terrace	Model: RB911G-2HPnD-12S	FCC ID: TV7RB911G2HPND
Louisburg, KS 66053	Test #: 180509	IC: 7442A-911G2HPND
Phone/Fax: (913) 837-3214	Test to: 47CFR 15.247, RSS-247	Date: June 26, 2018
Revision 2	File: Mikrotikls RB9112HPnD12S DTS TstRpt 180509 r2	Page 2 of 64

Table of Contents

TABLE OF CONTENTS.....	3
REVISIONS.....	6
FORWARD	7
OPINION / INTERPRETATION OF RESULTS	7
EQUIPMENT TESTED.....	8
EQUIPMENT FUNCTION AND CONFIGURATION.....	8
Equipment Configuration.....	9
APPLICANT COMPANY INFORMATION	10
EQUIPMENT INFORMATION.....	10
Accessories	11
Table for Filed Antennas	11
Product Details	11
Antenna and Bandwidth.....	12
Table for Carrier Frequencies	12
Table for Test Modes	13
Test Result of Occupied Bandwidth	15
APPLICATION FOR CERTIFICATION.....	16
APPLICABLE STANDARDS & TEST PROCEDURES	17
EQUIPMENT TESTING PROCEDURES	17
AC Line Conducted Emission Test Procedure	17
Radiated Emission Test Procedure.....	18
Antenna Port Conducted Emission Test Procedure.....	18
Diagram 1 Test arrangement for Conducted emissions	19

Diagram 2 Test arrangement for radiated emissions of tabletop equipment.....20

Diagram 3 Test arrangement for radiated emissions tested on Open Area Test Site (OATS).....21

Diagram 4 Test arrangement for Antenna Port Conducted emissions21

LIST OF TEST EQUIPMENT 22

TEST SITE LOCATIONS 23

UNITS OF MEASUREMENTS 23

ENVIRONMENTAL CONDITIONS..... 23

INTENTIONAL RADIATORS..... 23

Antenna Requirements23

Restricted Bands of Operation.....24

 Table 1 General Radiated Emissions in Restricted Bands Data (802.11b/g/n worst-case).....24

 Table 2 General Radiated Emissions in Restricted Bands Data (802.11n40 worst-case).....25

Summary of Results for Radiated Emissions in Restricted Bands25

AC Line Conducted Emissions Procedure26

 Figure 1 AC Line Conducted Emissions Line 1 Configuration #127

 Figure 2 AC Line Conducted Emissions Line 2 Configuration #127

 Table 3 AC Line Conducted Emissions Data (Highest Emissions Line L1) Configuration #128

 Table 4 AC Line Conducted Emissions Data (Highest Emissions Line L2) Configuration #128

 Figure 3 AC Line Conducted Emissions Line 1 Configuration #229

 Figure 4 AC Line Conducted Emissions Line 2 Configuration #229

 Table 5 AC Line Conducted Emissions Data (Highest Emissions Line L1) Configuration #230

 Table 6 AC Line Conducted Emissions Data (Highest Emissions Line L2) Configuration #230

Summary of Results for AC Line Conducted Emissions30

General Radiated Emissions Procedure.....31

 Table 7 General Radiated Emissions from EUT Data (Highest Emissions).....32

Summary of Results for General Radiated Emissions32

Operation in the 2400-2483.5 MHz Frequency Band.....33

 Figure 5 Plot of Transmitter Emissions (Across Operational Band 802.11b, Chain 0)34

Figure 6 Plot of Transmitter Emissions (Across Operational Band 802.11b, Chain 1)	34
Figure 7 Plot of Transmitter Emissions (Across Operational Band, 802.11g, Chain 0)	35
Figure 8 Plot of Transmitter Emissions (Across Operational Band, 802.11g, Chain 1)	35
Figure 9 Plot of Transmitter Emissions (Across Operational Band, 802.11n (20), Chain 0)	36
Figure 10 Plot of Transmitter Emissions (Across Operational Band, 802.11n (20), Chain 1)	36
Figure 11 Plot of Transmitter Emissions (Across Operational Band, 802.11n (40), Chain 0)	37
Figure 12 Plot of Transmitter Emissions (Across Operational Band, 802.11n (40), Chain 1)	37
Figure 13 Plot of Transmitter Low Band Edge (802.11b, Chain 0).....	38
Figure 14 Plot of Transmitter Low Band Edge (802.11b, Chain 1).....	38
Figure 15 Plot of Transmitter Low Band Edge (802.11g, Chain 0).....	39
Figure 16 Plot of Transmitter Low Band Edge (802.11g, Chain 1).....	39
Figure 17 Plot of Transmitter Low Band Edge (802.11n (20), Chain 0)	40
Figure 18 Plot of Transmitter Low Band Edge (802.11n (20), Chain 1)	40
Figure 19 Plot of Transmitter Low Band Edge (802.11n (40), Chain 0)	41
Figure 20 Plot of Transmitter Low Band Edge (802.11n (40), Chain 1)	41
Figure 21 Plot of Transmitter High Band Edge (802.11b, Chain 0)	42
Figure 22 Plot of Transmitter High Band Edge (802.11b, Chain 1)	42
Figure 23 Plot of Transmitter High Band Edge (802.11g, Chain 0)	43
Figure 24 Plot of Transmitter High Band Edge (802.11g, Chain 1)	43
Figure 25 Plot of Transmitter High Band Edge (802.11n (20), Chain 0)	44
Figure 26 Plot of Transmitter High Band Edge (802.11n (20), Chain 1)	44
Figure 27 Plot of Transmitter High Band Edge (802.11n (40), Chain 0)	45
Figure 28 Plot of Transmitter High Band Edge (802.11n (40), Chain 1)	45
Figure 29 Plot of Transmitter 6-dB Occupied Band Width (802.11b, Chain 0)	46
Figure 30 Plot of Transmitter 6-dB Occupied Band Width (802.11b, Chain 1)	46
Figure 31 Plot of Transmitter 6-dB Occupied Band Width (802.11g, Chain 0)	47
Figure 32 Plot of Transmitter 6-dB Occupied Band Width (802.11g, Chain 1)	47
Figure 33 Plot of Transmitter 6-dB Occupied Band Width (802.11n (20), Chain 0)	48
Figure 34 Plot of Transmitter 6-dB Occupied Band Width (802.11n (20), Chain 1)	48
Figure 35 Plot of Transmitter 6-dB Occupied Band Width (802.11n (40), Chain 0)	49
Figure 36 Plot of Transmitter 6-dB Occupied Band Width (802.11n (40), Chain 1)	49
Figure 37 Plot of Transmitter 99% Occupied Band Width (802.11b, Chain 0).....	50
Figure 38 Plot of Transmitter 99% Occupied Band Width (802.11b, Chain 1).....	50
Figure 39 Plot of Transmitter 99% Occupied Band Width (802.11g, Chain 0).....	51
Figure 40 Plot of Transmitter 99% Occupied Band Width (802.11g, Chain 1).....	51
Figure 41 Plot of Transmitter 99% Occupied Band Width (802.11n (20), Chain 0)	52

Figure 42 Plot of Transmitter 99% Occupied Band Width (802.11n (20), Chain 1)	52
Figure 43 Plot of Transmitter 99% Occupied Band Width (802.11n (40), Chain 0)	53
Figure 44 Plot of Transmitter 99% Occupied Band Width (802.11n (40), Chain 1)	53
Transmitter Emissions Data.....	54
Table 8 Transmitter Power and Emissions (Chain 0)	54
Table 9 Transmitter Power and Emissions (Chain 1)	55
Table 10 Transmitter Power and PSD Combined Chains.....	56
Table 11 Transmitter Radiated Emissions (802.11b/g/n worst-case)	57
Table 12 Transmitter Radiated Emissions (802.11n40 worst-case).....	58
Summary of Results for Transmitter Radiated Emissions of Intentional Radiator.....	59
STATEMENT OF MODIFICATIONS AND DEVIATIONS	59
ANNEX.....	60
Annex A Measurement Uncertainty Calculations.....	61
Annex B Rogers Labs Test Equipment List.....	62
Annex C Rogers Qualifications	63
Annex D Rogers Labs Certificate of Accreditation.....	64

Revisions

Revision 2 Issued June 25, 2018 – corrected type errors in reported power pages 7 and 55
Revision 1 Issued June 19, 2018

Forward

The following information is submitted for consideration in obtaining Grant of Certification for License Exempt Digital Transmission System Intentional Radiator operating under 47CFR Paragraph 15.247 and RSS-247 Issue 2 Digital Modulation transmitter operation in the 2412-2462 MHz band.

Name of Applicant: Mikrotikls SIA FRN: 0014431100
Brivibas gatve 214i
Riga Latvia LV-1039

Model: RB911G-2HPnD-12S
FCC ID: TV7RB911G2HPND IC: 7442A-911G2HPND

Frequency Range: 2412-2462 MHz (802.11b/g/n mode operation), 2422-2452 MHz
(802.11n 40 MHz channel operation)

Operating Power: Highest total average power 20 MHz Channel 0.022 Watts, highest peak power 20 MHz Channel 0.250 Watts, 99% OBW 802.11b – 13,925 kHz, 802.11g - 18,040 kHz, 802.11n20 - 18,060 kHz

Highest total average power 40 MHz Channel 0.001 Watts, peak power 40 MHz Channel 0.015 Watts, 99% OBW 38,550 kHz

Opinion / Interpretation of Results

Tests Performed	Margin (dB)	Results
Restricted Frequency Bands 15.205, RSS-GEN 8.10	-3.5	Complies
AC Line Conducted 15.207, RSS-GEN 7.2.4	-4.2	Complies
Radiated Emissions 15.209, RSS-GEN 7.2.5	-6.1	Complies
Harmonic Emissions per 15.247, RSS-247	-5.2	Complies
Peak Power Spectral Density per 15.247, RSS-247	-19.4	Complies

Equipment Tested

<u>Equipment</u>	<u>Model</u>	<u>Serial Number</u>	<u>FCC I.D.</u>
EUT	RB911G-2HPnD-12S	84AD08CAE425/806/r2	TV7RB911G2HPND
EUT #2	RB911G-2HPnD-12S	84AD08300865/806/r2	TV7RB911G2HPND
AC Adapter	SAW30-240-0800U	N/A	N/A
Adapter	POE	N/A	N/A
Dell Studio XPS	921LBN1	N/A	N/A

Test results in this report relate only to the items tested.

Equipment Function and Configuration

The EUT is a 2412-2462 MHz (Dual Chain (2 Tx chains) Multiple Input Multiple Out (MIMO) Digital Transmission System. The design provides operational capabilities across the 2412-2462 MHz Digital Transmissions System. The EUT offers broadband wireless connectivity to transmit and receive data. The design utilizes integral antenna system as documented in this filing. The EUT provides 8-30 Vdc power input and single communication interface port and requires direct current power provided from either a Direct current supply (AC/DC adapter) or Power Over Ethernet (POE) and AC/DC adapter. For testing purposes, the EUT transceiver was connected to the manufacturer supplied POE and AC/DC power supply and communicating to the laptop computer through the Ethernet network interface. This configuration provided operational control of the EUT and communications over the network interface between the EUT and supporting computer system. The design provides no other interfacing options than those presented in this report. Two samples were provided for testing, one as production equipment and the second modified by replacing the integral antenna system with radio frequency connectors (RF connectors). The RF connectors allowed testing of transmitter performance at the transmitter at the antenna port of each chain. For testing purposes, the RB911G-2HPnD-12S test sample was configured to transmit in available data modes receiving power from the manufacturer provided AC/DC power adapter and POE as presented below. As requested by the manufacturer the equipment was tested for emissions compliance using the available configurations with the worst-case data presented. Test results in this report relate only to the products described in this report.

Equipment Configuration

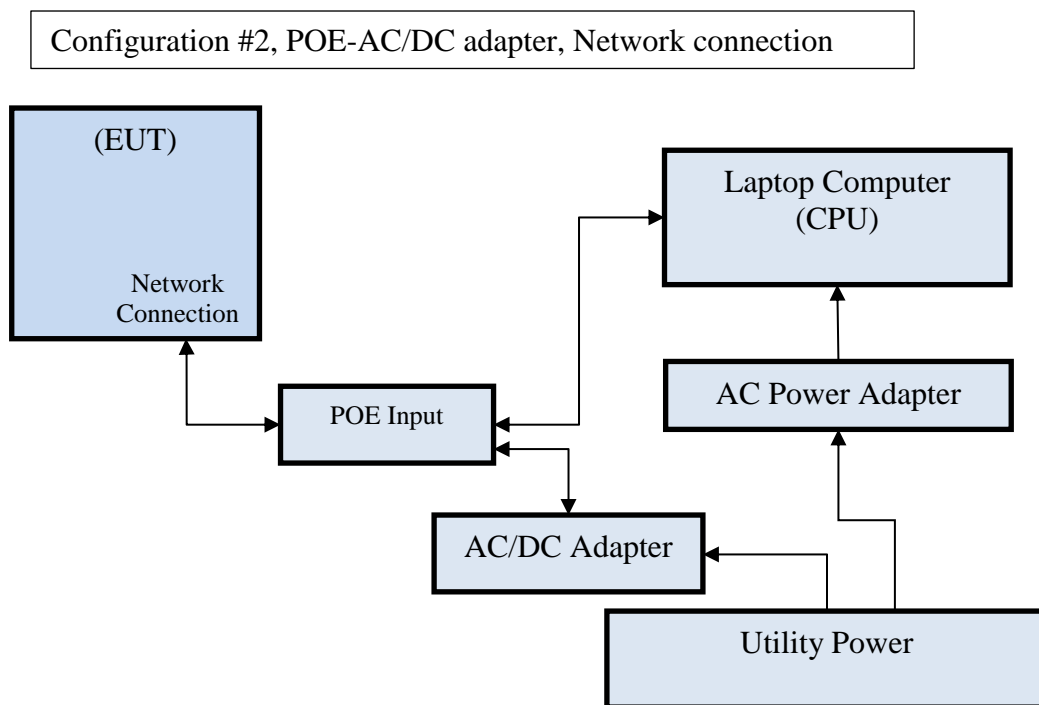
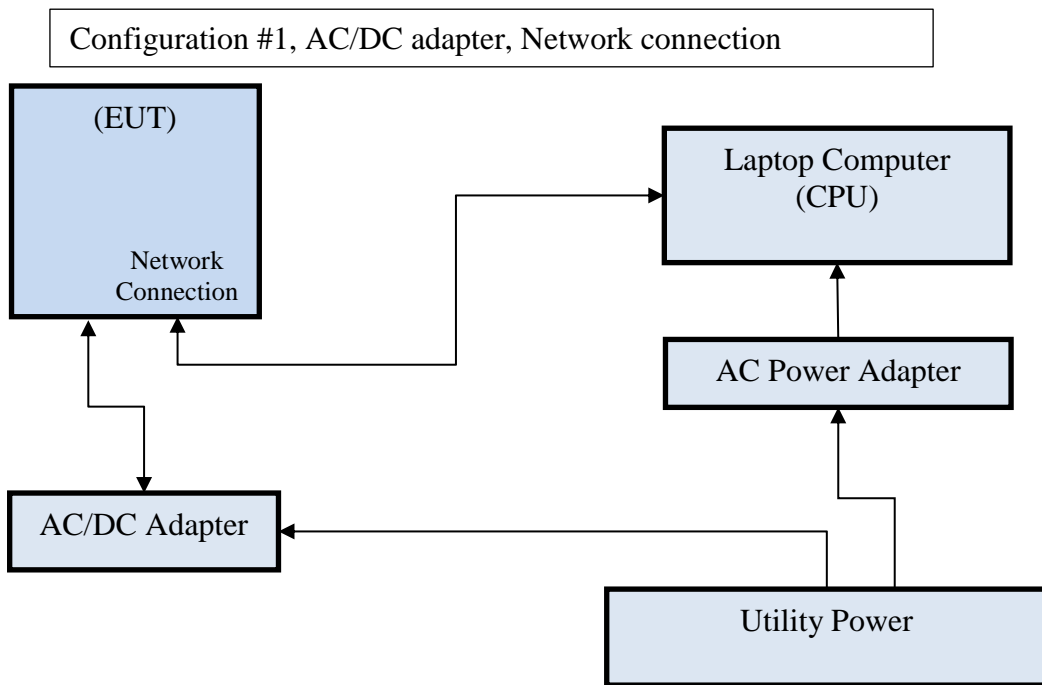

Applicant Company information

Applicants Company	MikroTik (“Mikrotīkls, SIA”)
Applicants Address	Brivibas gatve 214i, Riga Latvia LV-1039
FCC Identifier	TV7RB911G2HPND
Industry Canada Identifier	7442A-911G2HPND
Manufacturer Company	MikroTik (“Mikrotīkls, SIA”)
Manufacturer Address	Brivibas gatve 214i, Riga Latvia LV-1039

Equipment information

Product Marketing Name (PMN): The PMN is the name or model number under which the product will be marketed/offered for sale in Canada. If the product has PMN, it must be provided.	mANTBox 2 12S
Unique Product Number (UPN): The applicant, made up of a maximum of 11 alphanumeric characters (A-Z, 0-9), assigns the UPN.	7442A-911G2HPND
Hardware Version Identification Number (HVIN): The HVIN identifies hardware specifications of a product version. The HVIN replaces the ISED Model Number in the legacy E-filing System. An HVIN is required for all products for certification applications.	RB911G-2HPnD-12S
Host Marketing Name (HMN) (if applicable): The HMN is the name or model number of a final product, which contains a certified radio module.	
Brand Name	
Model Number	RB911G-2HPnD-12S
Test Rule Part(s)	47CFR Parts 15C, 15.247, and RSS-247
Test Frequency Range	2412-2462 MHz
Project Number	180509
Submission Type	Certification

Accessories

AC Power Adapter	SAW30-240-0800U
Power Over Ethernet (POE) adapter	POE

Table for Filed Antennas

Ant.	Brand	Model Name	P/N	Antenna Type	Connector	Gain (dBi)	
						2.4GHZ	5GHZ
1	Mikrotikls		N/A	Integral Sectoral	N/A	12	

Product Details

Items	Description
Product Type	WLAN 2.4 GHz
Radio Type	Transceiver
Power Type	POE adapter with External Power Supply
Modulation	IEEE 802.11a: OFDM IEEE 802.11a/n: see the below table
Data Modulation	IEEE 802.11 a/n: Not Applicable IEEE 802.11ac: Not Applicable IEEE 802.11 g/n: OFDM (BPSK/QPSK/16QAM/64QAM) IEEE 802.11 b: DSSS
Data Rate (Mbps)	IEEE 802.11a/g: OFDM (6/9/12/18/24/36/48/54) IEEE 802.11n/ac: Not Applicable IEEE 802.11b: (1/2/2s/5/5s/11/11s)
Frequency Range	2400-2483.5 MHz
Channel Number	802.11b: 11 for 20MHz bandwidth 802.11g/n: 11 for 20MHz bandwidth; 5 for 40MHz bandwidth 802.11a/n: Not Applicable 802.11 a/c: Not Applicable
Maximum Combined Conducted Output Power	802.11 b: 0.020 Watts 802.11 g: 0.022 Watts 802.11 n (HT-20): 0.022 Watts 802.11 n (HT-40): 0.001 Watts Band 1: IEEE 802.11a: IEEE 802.11a/n MCS0/Nss1 (VHT20): IEEE 802.11a/n MCS0/Nss1 (VHT40): IEEE 802.11ac MCS0/Nss1 (VHT80): Band 3: IEEE 802.11a: IEEE 802.11a/n MCS0/Nss1 (VHT20): IEEE 802.11a/n MCS0/Nss1 (VHT40): IEEE 802.11ac MCS0/Nss1 (VHT80):

Rogers Labs, Inc. Mikrotikls SIA S/N: 84AD08CAE425, 84AD08300865
 4405 W. 259th Terrace Model: RB911G-2HPnD-12S FCC ID: TV7RB911G2HPND
 Louisburg, KS 66053 Test #: 180509 IC: 7442A-911G2HPND
 Phone/Fax: (913) 837-3214 Test to: 47CFR 15.247, RSS-247 Date: June 26, 2018
 Revision 2 File: Mikrotikls RB9112HPnD12S DTS TstRpt 180509 r2 Page 11 of 64

Carrier Frequencies	Please refer to Table for Carrier Frequencies
Antenna	1) <u>2.4 GHz antenna</u> : Integral 12-dBi gain 2) <u>5 GHz antenna</u> : – Not Applicable 3) No External antenna options.
Communication Mode	Device operates as a dual channel input / output, 2.4 GHz Digital Transmission System
Beamforming Function	Without beamforming
Operating Mode	2.4 GHz

Antenna and Bandwidth

Antenna	TX chains		
Bandwidth Mode	20 MHz	40 MHz	80 MHz
IEEE 802.11b	1 from above list		
IEEE 802.11g	1 from above list		
IEEE 802.11n (HT20)	1 from above list		
IEEE 802.11n (HT40)		1 from above list	
IEEE 802.11a			
IEEE 802.11n			
IEEE 802.11ac			

Table for Carrier Frequencies

For 20MHz bandwidth systems, use Channel 1,6,11, 36, 40, 44, 48, 149, 153, 157, 161, 165.

For 40MHz bandwidth systems, use Channel 38, 46, 151, 159.

Frequency Band	Channel No.	Frequency	Channel No.	Frequency
2400-2483.5MHz	1	2412	2	2422
	6	2437	7	2447
	11	2462	10	2452
5150-5250MHz U-NII-1				
5725-5850MHz U-NII-3				

Table for Test Modes

Preliminary tests were performed in different data rates to define the worst radiated emission. The data rate shown in the table below is the worst-case rate with respect to the specific test item. Investigation has been done on all possible configurations while searching the worst cases. The following table is a list of the test modes investigated for this report.

Test Items	Mode	Data Rate	Channel	Chain(s)
Max. Conducted Output Power	802.11b	11	1,6,11	1,2
	802.11g	54	1,6,11	1,2
	802.11n HT20	65	1,6,11	1,2
	802.11n HT40	135	2,7,10	1,2
	11 a BPSK			
	11a/n HT20			
	11a/n HT40			
	11ac VHT80			
Power Spectral Density	802.11b		1,6,11	1,2
	802.11g		1,6,11	1,2
	802.11n HT20		1,6,11	1,2
	802.11n HT40		2,7,10	1,2
	11a BPSK			
	11a/n HT20			
	11a/n HT40			
	11ac VHT80			
26dB, 99% Occupied Bandwidth Measurement	802.11b		1,6,11	1,2
	802.11g		1,6,11	1,2
	802.11n HT20		1,6,11	1,2
	802.11n HT40		2,7,10	1,2
	11a BPSK			
	11a/n HT20			
	11a/n HT40			
	11ac VHT80			

6dB Spectrum Bandwidth Measurement	802.11b			1,6,11	1,2
	802.11g			1,6,11	1,2
	802.11n HT20			1,6,11	1,2
	802.11n HT40			2,7,10	1,2
	802.11a BPSK				
	802.11a/n HT20				
	802.11a/n HT40				
	802.11ac VHT80				
Radiated Emission Below 1GHz			-	-	1,2
Radiated Emission Above 1GHz	802.11b			1,6,11	1,2
	802.11g			1,6,11	1,2
	802.11n HT20			1,6,11	1,2
	802.11n HT40			2,7,10	1,2
	11a BPSK				
	802.11a/n HT20				
	802.11a/n HT40				
	802.11ac VHT80				
Band Edge Emission	802.11b			1,6,11	1,2
	802.11g			1,6,11	1,2
	802.11n HT20			1,6,11	1,2
	802.11n HT40			2,7,10	1,2
	11a BPSK				
	802.11a/n HT20				
	802.11a/n HT40				
	802.11ac VHT80				
Frequency Stability	20MHz	Band 1&3	-	40/157	
	40MHz	Band 1&3	-	38/151	
	80MHz	Band 1&3	-	42,155	

Test Result of Occupied Bandwidth

Mode	Frequency	26 dB Bandwidth (kHz)	99% Occupied Bandwidth (kHz)	6 dB Bandwidth (kHz)
802.11b	2412 MHz	N/A	13,925.0	10,100.0
	2437 MHz	N/A	13,925.0	10,100.0
	2462 MHz	N/A	13,925.0	10,100.0
802.11g	2412 MHz	N/A	17,475.0	16,400.0
	2437 MHz	N/A	17,450.0	16,350.0
	2462 MHz	N/A	17,475.0	16,375.0
802.11n (HT20)	2412 MHz	N/A	18,060.0	16,325.0
	2437 MHz	N/A	18,030.0	16,375.0
	2462 MHz	N/A	18,060.0	16,375.0
802.11n (HT40)	2422 MHz	N/A	38,175.0	36,375.0
	2447 MHz	N/A	38,100.0	36,450.0
	2452 MHz	N/A	37,950.0	36,300.0

Application for Certification

- (1) Manufacturer: Mikrotikls SIA
Brivibas gatve 214i
Riga Latvia LV-1039
- (2) Identification: Model: RB911G-2HPnD-12S
FCC I.D.: TV7RB911G2HPND IC: 7442A-911G2HPND
- (3) Instruction Book:
Refer to Exhibit for Instruction Manual.
- (4) Description of Circuit Functions:
Refer to Exhibit of Operational Description.
- (5) Block Diagram with Frequencies:
Refer to Exhibit of Operational Description.
- (6) Report of Measurements:
Report of measurements follows in this Report.
- (7) Photographs: Construction, Component Placement, etc.:
Refer to Exhibit for photographs of equipment.
- (8) List of Peripheral Equipment Necessary for operation. The equipment operates from power received from authorized AC/DC power adapter and POE. The EUT provides single Ethernet port for communications and single power input port. During testing, the EUT was powered from the POE and AC/DC power supply and connected to CPU through a network cable.
- (9) Transition Provisions of 47CFR 15.37 are not requested
- (10) Not Applicable. The unit is not a scanning receiver.
- (11) Not Applicable. The EUT does not operate in the 59 – 64 GHz frequency band.
- (12) The equipment is not software defined and this section is not applicable.
- (13) Applications for certification of U-NII devices in the 5.15-5.35 GHz and the 5.47-5.85 GHz bands must include a high-level operational description of the security procedures that control the radio frequency operating parameters and ensure that unauthorized modifications cannot be made. Not applicable to this filing.
- (14) Contain at least one drawing or photograph showing the test set-up for each of the required types of tests applicable to the device for which certification is requested. These drawings or photographs must show enough detail to confirm other information contained in the test report. Any photographs used must be focused originals without glare or dark spots and must clearly show the test configuration used. This information is provided in this report and Test Setup Exhibits provided with the application filing.

Applicable Standards & Test Procedures

The following information is submitted in accordance e-CFR Title 47 dated May 9, 2018, Part 2, Subpart J, Paragraphs 2.907, 2.911, 2.913, 2.925, 2.926, 2.1031(b), and applicable parts of paragraph 15, Part 15C Paragraph 15.247 and Industry Canada RSS-247 Issue 2 and RSS-Gen Issue 4. Test procedures used are the established Methods of Measurement of Radio-Noise Emissions as described in ANSI C63.10-2013, KDB 558074 D01 v04, KDB 662911 D01 Multiple Transmitter Output v02r01, RSS-247 Issue 2, and RSS-GEN Issue 5.

Equipment Testing Procedures

AC Line Conducted Emission Test Procedure

Testing for the AC line-conducted emissions was performed as defined in ANSI C63.10-2013. The test setup, including the EUT, was arranged in the test configurations presented during testing. The test configuration was placed on a 1 x 1.5-meter wooden bench, 0.8 meters high located in a screen room. The power lines of the system were isolated from the power source using a standard LISN with a 50- μ Hy choke. EMI was coupled to the spectrum analyzer through a 0.1 μ F capacitor internal to the LISN. The LISN was positioned on the floor beneath the wooden bench supporting the EUT. The power lines and cables were draped over the back edge of the table. Refer to diagram one showing typical test arrangement and photographs in exhibits for EUT placement used during testing.

Radiated Emission Test Procedure

Radiated emission testing was performed as required and specified in ANSI C63.10-2013 and referenced KDB documents. The EUT was placed on a rotating 0.9 x 1.2-meter platform, elevated as required above the ground plane at a distance of 3 meters from the FSM antenna. EMI energy was maximized by equipment placement, raising and lowering the FSM antenna, changing the antenna polarization, and by rotating the turntable. Each emission was maximized before data was taken using a spectrum analyzer. The frequency spectrum from 9 kHz to 25,000 MHz was searched for during preliminary investigation. Refer to diagrams two and three showing typical test arrangement and photographs in the test setup exhibits for specific EUT placement during testing.

Antenna Port Conducted Emission Test Procedure

The EUT was assembled as required for operation placed on a benchtop. This configuration provided the ability to connect test equipment to the provided test antenna port. Antenna Port conducted emissions testing was performed on test sample #2 as required in the regulations and specified in ANSI C63.10-2013. Testing was completed on a laboratory bench in a shielded room. The active antenna port of the unlicensed wireless device was connected to appropriate attenuation and the spectrum analyzer. Refer to diagram four showing typical test arrangement and photographs in the test setup exhibits for specific EUT placement during testing.

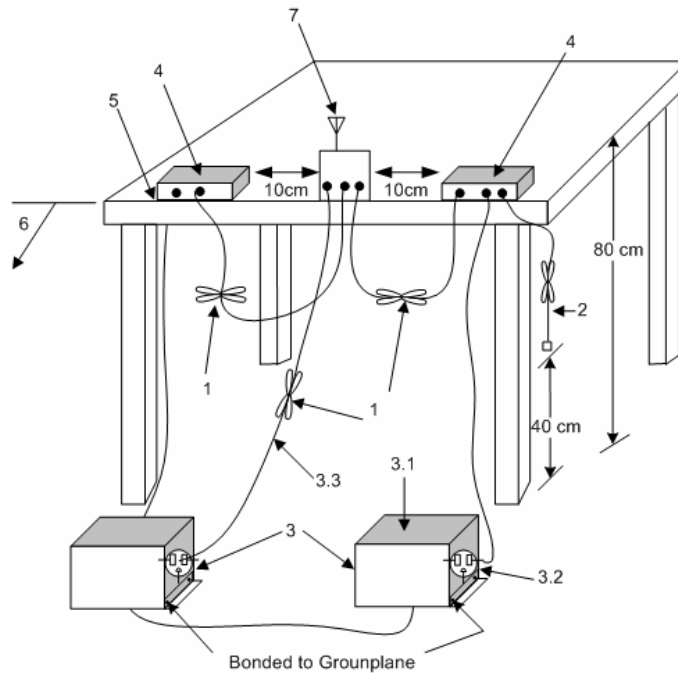

1. Interconnecting cables that hang closer than 40 cm to the ground plane shall be folded back and forth in the center forming a bundle 30 cm to 40 cm long see (see 6.2.3.2).
2. The I/O cables that are not connected to an accessory shall be bundled in the center. The end of the cable may be terminated, if required, using the correct terminating impedance. The overall length shall not exceed 1 m (see 6.2.2).
3. EUT connected to one LISN. Unused LISN measuring port connectors shall be terminated in 50 Ω loads. LISN may be placed on top of, or immediately beneath, reference ground plane (see 6.2.2 and 6.2.3).
 - 3.1 All other equipment powered from additional LISN(s).
 - 3.2 Multiple-outlet strip can be used for multiple power cords of non-EUT equipment.
 - 3.3 LISN at least 80 cm from nearest part of EUT chassis
4. Non-EUT components of EUT system being tested
5. Rear of EUT, including peripherals, shall all be aligned and flush with edge of tabletop (see 6.2.3.2).
6. Edge of tabletop shall be 40 cm removed from a vertical conducting plane that is bonded to the ground plane (see 6.2.2 for options).
7. Antenna may be integral or detachable. If detachable, the antenna shall be attached for this test.

Diagram 1 Test arrangement for Conducted emissions

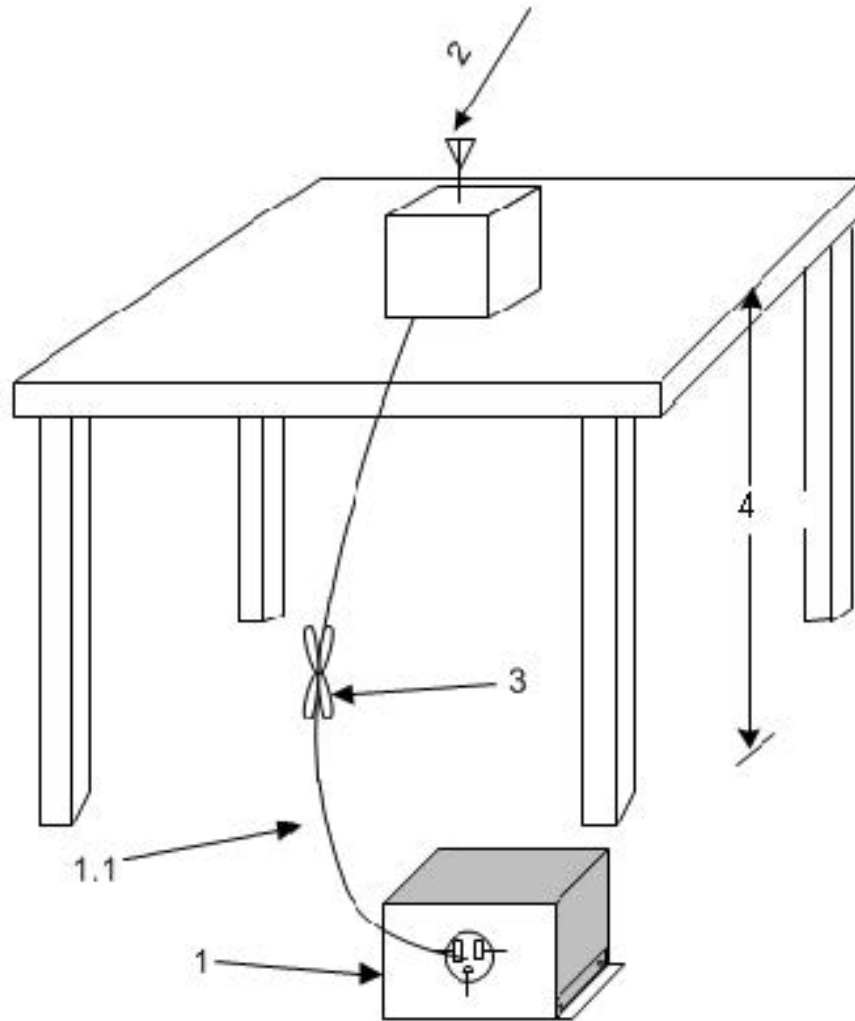

1. A LISN is optional for radiated measurements between 30 MHz and 1000 MHz but not allowed for measurements below 30 MHz and above 1000 MHz (see 6.3.1). If used, then connect EUT to one LISN. Unused LISN measuring port connectors shall be terminated in 50 Ω loads. The LISN may be placed on top of, or immediately beneath, the reference ground plane (see 6.2.2 and 6.2.3.2).
 - 1.1 LISN spaced at least 80 cm from nearest part of EUT chassis.
2. Antenna can be integral or detachable, depending on the EUT (see 6.3.1).
3. Interconnecting cables that hang closer than 40 cm to the ground plane shall be folded back and forth in the center forming a bundle 30 cm to 40 cm long (see 6.3.1).
4. For emission measurements at or below 1 GHz, the table height shall be 80 cm. For emission measurements above 1 GHz, the table height shall be 1.5 m for measurements, except as otherwise specified (see 6.3.1 and 6.6.3.1).

Diagram 2 Test arrangement for radiated emissions of tabletop equipment

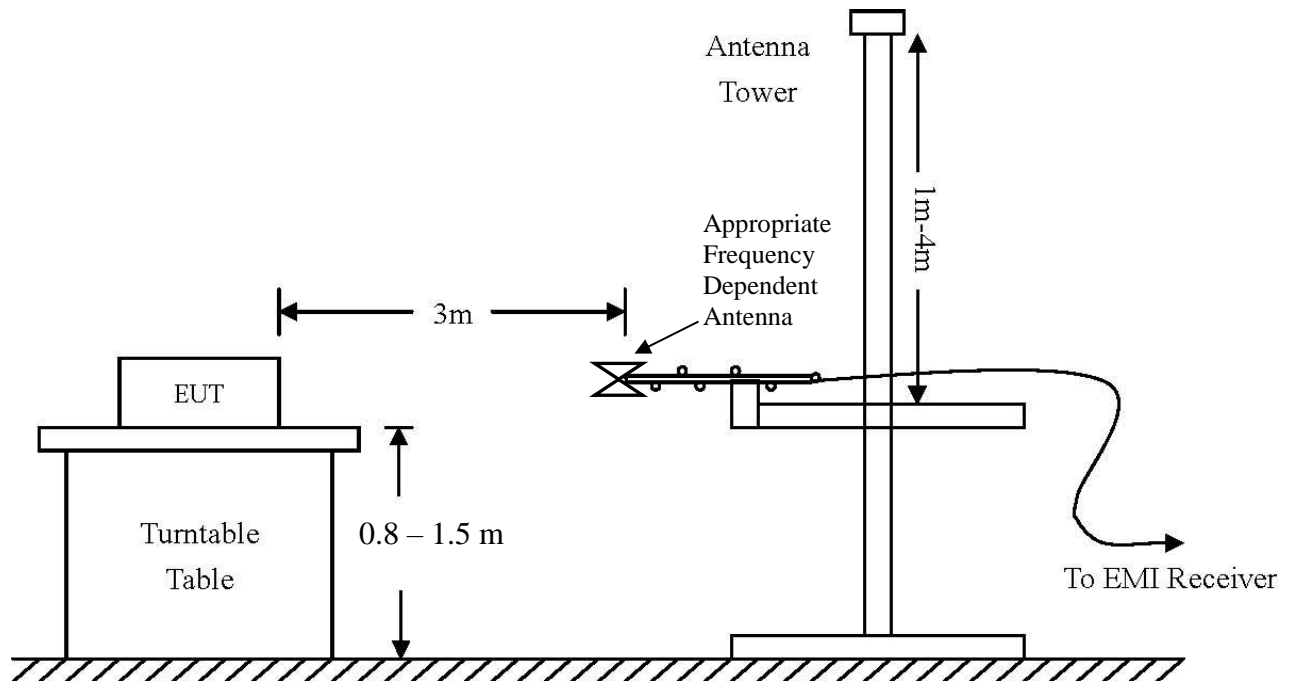

Frequency: 9 kHz-30 MHz	Frequency: 30 MHz- 1 GHz	Frequency: Above 1 GHz
Loop Antenna	Broadband Biconilog	Horn
RBW = 9 kHz	RBW = 120 kHz	RBW = 1 MHz
VBW = 30 kHz	VBW = 120 kHz	VBW = 1 MHz
Sweep time = Auto	Sweep time = Auto	Sweep time = Auto
Detector = PK, QP	Detector = PK, QP	Detector = PK, AV
Antenna Height 1m	Antenna Height 1-4m	Antenna Height 1-4m

Diagram 3 Test arrangement for radiated emissions tested on Open Area Test Site (OATS)

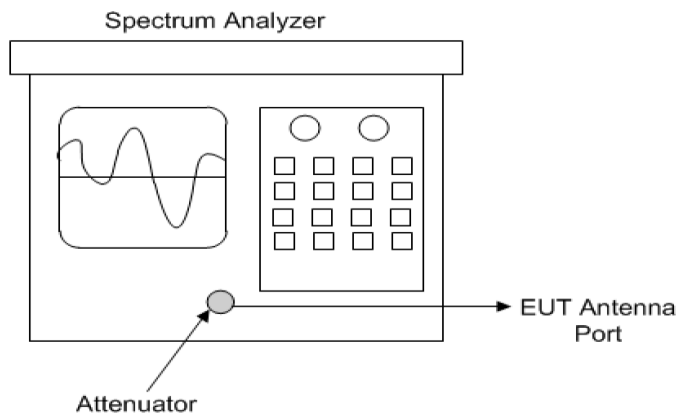

Diagram 4 Test arrangement for Antenna Port Conducted emissions

List of Test Equipment

<u>Equipment</u>	<u>Manufacturer</u>	<u>Model (SN)</u>	<u>Band</u>	<u>Cal Date(m/d/y)</u>	<u>Due</u>
<input checked="" type="checkbox"/> LISN	FCC	FCC-LISN-50-2-10(1PA) (160611)	.15-30MHz	5/2/2018	5/2/2019
<input checked="" type="checkbox"/> LISN	Compliance Design	FCC-LISN-2.Mod.cd,	.15-30MHz	10/24/2017	10/24/2018
<input checked="" type="checkbox"/> Cable	Huber & Suhner Inc.	Sucoflex102ea(L10M)(303073)	9kHz-40 GHz	10/24/2017	10/24/2018
<input checked="" type="checkbox"/> Cable	Huber & Suhner Inc.	Sucoflex102ea(1.5M)(303069)	9kHz-40 GHz	10/24/2017	10/24/2018
<input checked="" type="checkbox"/> Cable	Huber & Suhner Inc.	Sucoflex102ea(1.5M)(303071)	9kHz-40 GHz	10/24/2017	10/24/2018
<input checked="" type="checkbox"/> Cable	Belden	RG-58 (L1-CAT3-11509)	9kHz-30 MHz	10/24/2017	10/24/2018
<input checked="" type="checkbox"/> Cable	Belden	RG-58 (L2-CAT3-11509)	9kHz-30 MHz	10/24/2017	10/24/2018
<input type="checkbox"/> Antenna	ARA	BCD-235-B (169)	20-350MHz	10/24/2017	10/24/2018
<input type="checkbox"/> Antenna	EMCO	3147 (40582)	200-1000MHz	10/24/2017	10/24/2018
<input checked="" type="checkbox"/> Antenna	ETS-Lindgren	3117 (200389)	1-18 GHz	5/2/2018	5/2/2020
<input type="checkbox"/> Antenna	Com Power	AH-118 (10110)	1-18 GHz	10/24/2017	10/24/2019
<input checked="" type="checkbox"/> Antenna	Com Power	AH-840 (101046)	18-40 GHz	5/15/2017	5/15/2019
<input checked="" type="checkbox"/> Antenna	Com Power	AL-130 (121055)	.001-30 MHz	10/24/2017	10/24/2018
<input checked="" type="checkbox"/> Antenna	Sunol	JB-6 (A100709)	30-1000 MHz	10/24/2017	10/24/2018
<input checked="" type="checkbox"/> Analyzer	Rohde & Schwarz	ESU40 (100108)	20Hz-40GHz	5/2/2018	5/2/2019
<input type="checkbox"/> Analyzer	Rohde & Schwarz	ESW44 (101534)	20Hz-44GHz	12/22/2017	12/22/2018
<input type="checkbox"/> Analyzer	Rohde & Schwarz	FS-Z60, 90, 140, and 220	40GHz-220GHz	12/22/2017	12/22/2019
<input type="checkbox"/> Analyzer	HP	8591EM (3628A00871)	9kHz-1.8GHz	5/2/2018	5/2/2019
<input type="checkbox"/> Analyzer	HP	8562A (3051A05950)	9kHz-125GHz	5/2/2018	5/2/2019
<input type="checkbox"/> Analyzer	HP External Mixers	11571, 11970	25GHz-110GHz	5/2/2018	5/2/2019
<input checked="" type="checkbox"/> Amplifier	Com-Power	PA-010 (171003)	100Hz-30MHz	10/24/2017	10/24/2018
<input checked="" type="checkbox"/> Amplifier	Com-Power	CPPA-102 (01254)	1-1000 MHz	10/24/2017	10/24/2018
<input checked="" type="checkbox"/> Amplifier	Com-Power	PAM-118A (551014)	0.5-18 GHz	10/24/2017	10/24/2018
<input checked="" type="checkbox"/> Power Meter	Agilent	N1911A with N1921A	0.05-40 GHz	5/2/2018	5/2/2019
<input type="checkbox"/> Generator	Rohde & Schwarz	SMB100A6 (100150)	20Hz-6 GHz	5/2/2018	5/2/2019
<input type="checkbox"/> Generator	Rohde & Schwarz	SMBV100A6 (260771)	20Hz-6 GHz	5/2/2018	5/2/2019
<input type="checkbox"/> RF Filter	Micro-Tronics	BRC50722 (009) 9G notch	30-1800 MHz	5/2/2018	5/2/2019
<input type="checkbox"/> RF Filter	Micro-Tronics	HPM50114 (017) 1.5G HPF	30-18000 MHz	5/2/2018	5/2/2019
<input type="checkbox"/> RF Filter	Micro-Tronics	HPM50117 (063) 3G HPF	30-18000 MHz	5/2/2018	5/2/2019
<input type="checkbox"/> RF Filter	Micro-Tronics	HPM50105 (059) 6G HPF	30-18000 MHz	5/2/2018	5/2/2019
<input type="checkbox"/> RF Filter	Micro-Tronics	BRM50702 (172) 2G notch	30-1800 MHz	5/2/2018	5/2/2019
<input type="checkbox"/> RF Filter	Micro-Tronics	BRC50703 (G102) 5G notch	30-1800 MHz	5/2/2018	5/2/2019
<input type="checkbox"/> RF Filter	Micro-Tronics	BRC50705 (024) 5G notch	30-1800 MHz	5/2/2018	5/2/2019
<input type="checkbox"/> RF Filter	Micro-Tronics	BRC17663 (001) 9G notch	30-1800 MHz	5/2/2018	5/2/2019
<input type="checkbox"/> Attenuator	Fairview	SA6NFNF100W-14 (1625)	30-1800 MHz	5/2/2018	5/2/2019
<input checked="" type="checkbox"/> Attenuator	Mini-Circuits	VAT-3W2+ (1735)	30-6000 MHz	5/2/2018	5/2/2019
<input checked="" type="checkbox"/> Attenuator	Mini-Circuits	VAT-3W2+ (1436)	30-6000 MHz	5/2/2018	5/2/2019
<input type="checkbox"/> Attenuator	Mini-Circuits	VAT-3W2+ (14362)	30-6000 MHz	5/2/2018	5/2/2019
<input type="checkbox"/> Attenuator	Mini-Circuits	VAT-3W2+ (1445)	30-6000 MHz	5/2/2018	5/2/2019
<input type="checkbox"/> Attenuator	Mini-Circuits	VAT-3W2+ (14452)	30-6000 MHz	5/2/2018	5/2/2019
<input type="checkbox"/> Attenuator	Mini-Circuits	VAT-6W2+ (1438)	30-6000 MHz	5/2/2018	5/2/2019
<input type="checkbox"/> Attenuator	Mini-Circuits	VAT-6W2+ (1736)	30-6000 MHz	5/2/2018	5/2/2019
<input type="checkbox"/> Attenuator	JFW Industries	50FH-010-10 (1)	30-18000 MHz	5/2/2018	5/2/2019
<input checked="" type="checkbox"/> Weather station	Davis	6312 (A70927D44N)		10/24/2017	10/24/2018

Rogers Labs, Inc. Mikrotikls SIA S/N: 84AD08CAE425, 84AD08300865
 4405 W. 259th Terrace Model: RB911G-2HPnD-12S FCC ID: TV7RB911G2HPND
 Louisburg, KS 66053 Test #: 180509 IC: 7442A-911G2HPND
 Phone/Fax: (913) 837-3214 Test to: 47CFR 15.247, RSS-247 Date: June 26, 2018
 Revision 2 File: Mikrotikls RB9112HPnD12S DTS TstRpt 180509 r2 Page 22 of 64

Test Site Locations

Conducted EMI	AC power line conducted emissions testing was performed in a shielded screen room located at Rogers Labs, Inc., Louisburg, KS
Radiated EMI	The radiated emissions tests were performed at the 3 meters, Open Area Test Site (OATS) located at Rogers Labs, Inc., Louisburg, KS
Site Registration	FCC Site Designation US5305, Industry Canada Registration: 3041A-1
Accreditation	NVLAP Accreditation Lab Code 200087-0

Units of Measurements

Conducted EMI	Data is in dB μ V; dB referenced to one microvolt
Radiated EMI	Data is in dB μ V/m; dB/m referenced to one microvolt per meter

Sample Calculation:

$$\begin{aligned} \text{RFS} &= \text{Radiated Field Strength, FSM} = \text{Field Strength Measured} \\ \text{A.F.} &= \text{Receive antenna factor, Gain} = \text{amplification gains and/or cable losses} \\ \text{RFS (dB}\mu\text{V/m @ 3m)} &= \text{FSM (dB}\mu\text{V)} + \text{A.F. (dB)} - \text{Gain (dB)} \end{aligned}$$

Environmental Conditions

Ambient Temperature	21.6° C
Relative Humidity	38%
Atmospheric Pressure	1015.4 mb

Intentional Radiators

As per 47CFR part 15 subpart C, and Industry Canada RSS-247, Issue 2, the following information is submitted for consideration and demonstration of compliance with regulation and standards.

Antenna Requirements

The EUT utilizes integral antenna system and offers no provision for antenna replacement. The antenna complies with the unique antenna connection requirements. The requirements of 15.203 are fulfilled there are no deviations or exceptions to the specification.

Restricted Bands of Operation

Spurious emissions falling in the restricted frequency bands of operation were measured at the on the OATS. The EUT utilizes frequency, determining circuitry, which generates harmonics falling in restricted bands. Emissions were investigated at the antenna port and OATS, using appropriate antennas or pyramidal horns, amplification stages, and spectrum analyzer. Peak and average amplitudes of frequencies above 1000 MHz were compared to the required limits with worst-case data presented below. Test procedures of ANSI C63.10-2013 were used during testing. No other significant emission was observed which fell into the restricted bands of operation. Computed radiated emission values account for measured radiated field strength, receive antenna correction factor, amplifier gain stage, and test system cable losses.

Table 1 General Radiated Emissions in Restricted Bands Data (802.11b/g/n worst-case)

Frequency in MHz	Horizontal Peak (dB μ V/m)	Horizontal Quasi-Peak (dB μ V/m)	Horizontal Average (dB μ V/m)	Vertical Peak (dB μ V/m)	Vertical Quasi-Peak (dB μ V/m)	Vertical Average (dB μ V/m)	Limit @ 3m (dB μ V/m)
2390.0	60.9	N/A	40.3	60.0	N/A	50.1	54.0
2483.5	64.1	N/A	43.8	59.0	N/A	50.5	54.0
4824.0	47.8	N/A	34.3	46.9	N/A	34.0	54.0
4874.0	47.6	N/A	34.5	47.0	N/A	34.2	54.0
4924.0	47.2	N/A	34.2	46.4	N/A	34.0	54.0
7236.0	50.3	N/A	38.1	51.1	N/A	37.8	54.0
7311.0	51.5	N/A	38.3	50.7	N/A	38.3	54.0
7386.0	81.4	N/A	38.4	50.7	N/A	38.4	54.0
12060.0	56.4	N/A	43.7	55.4	N/A	43.1	54.0
12185.0	57.4	N/A	44.7	57.2	N/A	44.4	54.0
12310.0	57.2	N/A	44.8	57.5	N/A	45.2	54.0

Other emissions present had amplitudes at least 20 dB below the limit. Peak and Quasi-Peak amplitude emissions are recorded above for frequency range below 1000 MHz. Peak and Average amplitude emissions are recorded above for frequency range above 1000 MHz.

Table 2 General Radiated Emissions in Restricted Bands Data (802.11n40 worst-case)

Frequency in MHz	Horizontal Peak (dBµV/m)	Horizontal Quasi-Peak (dBµV/m)	Horizontal Average (dBµV/m)	Vertical Peak (dBµV/m)	Vertical Quasi-Peak (dBµV/m)	Vertical Average (dBµV/m)	Limit @ 3m (dBµV/m)
2390.0	60.6	N/A	42.8	61.3	N/A	43.1	54.0
2483.5	64.0	N/A	43.0	63.3	N/A	44.3	54.0
4844.0	47.1	N/A	34.0	46.5	N/A	34.0	54.0
4894.0	46.6	N/A	33.9	46.7	N/A	34.0	54.0
4904.0	46.4	N/A	33.7	46.4	N/A	33.6	54.0
7266.0	50.7	N/A	37.9	50.5	N/A	38.0	54.0
7341.0	50.5	N/A	38.2	51.0	N/A	38.2	54.0
7356.0	51.1	N/A	38.3	50.8	N/A	38.2	54.0
12110.0	57.9	N/A	44.6	57.6	N/A	44.4	54.0
12235.0	57.3	N/A	44.7	57.5	N/A	44.8	54.0
12260.0	57.8	N/A	44.9	57.6	N/A	44.9	54.0

Other emissions present had amplitudes at least 20 dB below the limit. Peak and Quasi-Peak amplitude emissions are recorded above for frequency range below 1000 MHz. Peak and Average amplitude emissions are recorded above for frequency range above 1000 MHz.

Summary of Results for Radiated Emissions in Restricted Bands

The EUT demonstrated compliance with the emissions requirements of 47CFR 15.205, RSS-GEN and RSS-247, Issue 2 Intentional Radiators. The EUT provided a worst-case minimum margin of -3.5 dB below the emissions requirements in restricted frequency bands. Peak, Quasi-peak, and average amplitudes were checked for compliance with the regulations. Worst-case emissions are reported with other emissions found in the restricted frequency bands at least 20 dB below the requirements.

AC Line Conducted Emissions Procedure

The EUT was arranged in typical equipment configurations and placed on a 1 x 1.5-meter wooden bench 80 cm above the conducting ground plane, floor of a screen room. The bench was positioned 40 cm away from the wall of the screen room. The LISN was positioned on the floor of the screen room 80-cm from the rear of the EUT. Testing for the line-conducted emissions were the procedures of ANSI C63.10-2013 paragraph 6. The AC adapter for the EUT was connected to the LISN for line-conducted emissions testing. A second LISN was positioned on the floor of the screen room 80-cm from the rear of the supporting equipment of the EUT. All power cords except the EUT were then powered from the second LISN. EMI was coupled to the spectrum analyzer through a 0.1 µf capacitor, internal to the LISN. Power line conducted emissions testing were carried out individually for each current carrying conductor of the EUT support equipment. The excess length of lead between the system and the LISN receptacle was folded back and forth to form a bundle not exceeding 40 cm in length. The screen room, conducting ground plane, analyzer, and LISN were bonded together to the protective earth ground. Preliminary testing was performed to identify the frequency of each emission displaying the highest amplitude. The cables were repositioned to obtain maximum amplitude of measured EMI level. Once the worst-case configuration was identified, plots were made of the EMI from 0.15 MHz to 30 MHz then the data was recorded with maximum conducted emissions levels.

Refer to figures one and two for plots of the AC Line Conducted emissions of the EUT configuration #1 AC/DC Adapter and support equipment. Refer to figures three and four for plots of the AC Line Conducted emissions of the EUT configuration #2 POE-AC/DC Adapter and support equipment.

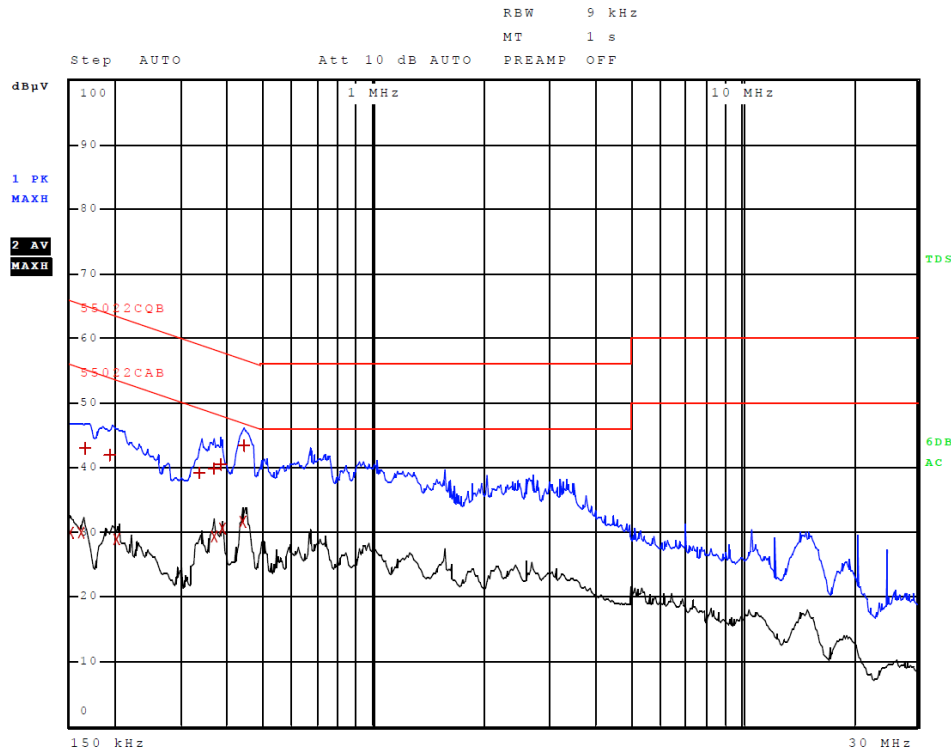

Figure 1 AC Line Conducted Emissions Line 1 Configuration #1

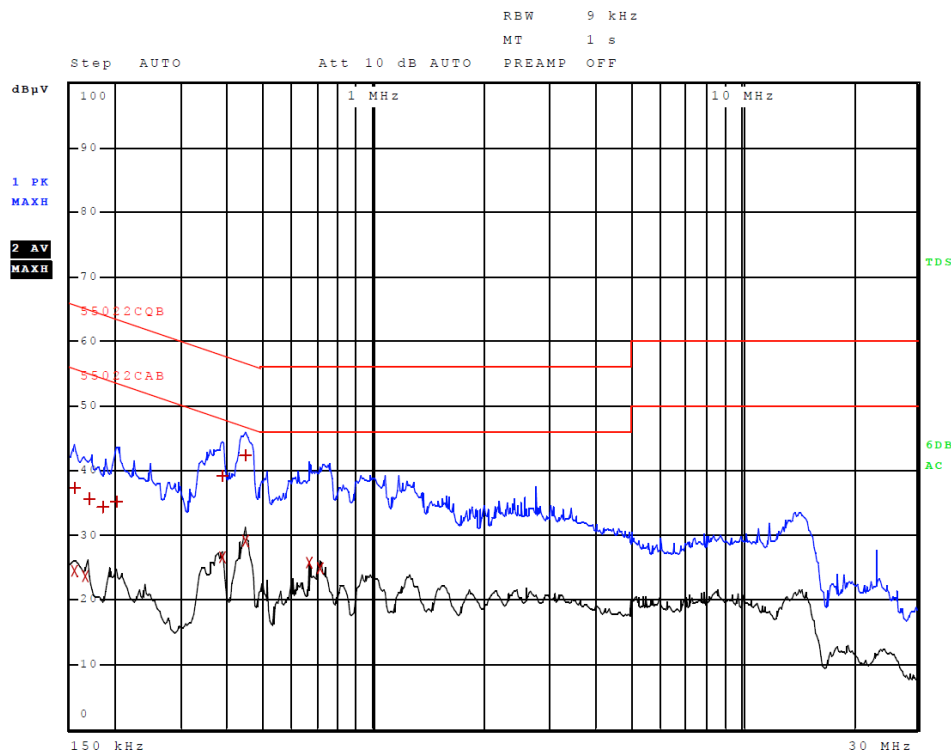

Figure 2 AC Line Conducted Emissions Line 2 Configuration #1

Table 3 AC Line Conducted Emissions Data (Highest Emissions Line L1) Configuration #1

Trace	Frequency	Level (dBµV)	Detector	Delta Limit/dB
2	150.000000000 kHz	29.92	Average	-26.08
2	162.000000000 kHz	29.90	Average	-25.46
1	166.000000000 kHz	42.95	Quasi Peak	-22.21
1	194.000000000 kHz	41.81	Quasi Peak	-22.05
2	202.000000000 kHz	28.91	Average	-24.61
1	338.000000000 kHz	39.12	Quasi Peak	-20.14
2	366.000000000 kHz	29.32	Average	-19.27
1	366.000000000 kHz	39.80	Quasi Peak	-18.79
1	382.000000000 kHz	40.51	Quasi Peak	-17.72
2	386.000000000 kHz	30.65	Average	-17.50
2	438.000000000 kHz	31.68	Average	-15.42
1	442.000000000 kHz	43.35	Quasi Peak	-13.68

Other emissions present had amplitudes at least 20 dB below the limit.

Table 4 AC Line Conducted Emissions Data (Highest Emissions Line L2) Configuration #1

Trace	Frequency	Level (dBµV)	Detector	Delta Limit/dB
1	154.000000000 kHz	37.20	Quasi Peak	-28.58
2	154.000000000 kHz	24.41	Average	-31.37
2	166.000000000 kHz	23.59	Average	-31.57
1	170.000000000 kHz	35.68	Quasi Peak	-29.28
1	186.000000000 kHz	34.35	Quasi Peak	-29.86
1	202.000000000 kHz	35.16	Quasi Peak	-28.37
2	386.000000000 kHz	26.51	Average	-21.64
1	386.000000000 kHz	39.14	Quasi Peak	-19.01
2	446.000000000 kHz	29.12	Average	-17.83
1	446.000000000 kHz	42.27	Quasi Peak	-14.68
2	666.000000000 kHz	25.64	Average	-20.36
2	714.000000000 kHz	24.90	Average	-21.10

Other emissions present had amplitudes at least 20 dB below the limit.

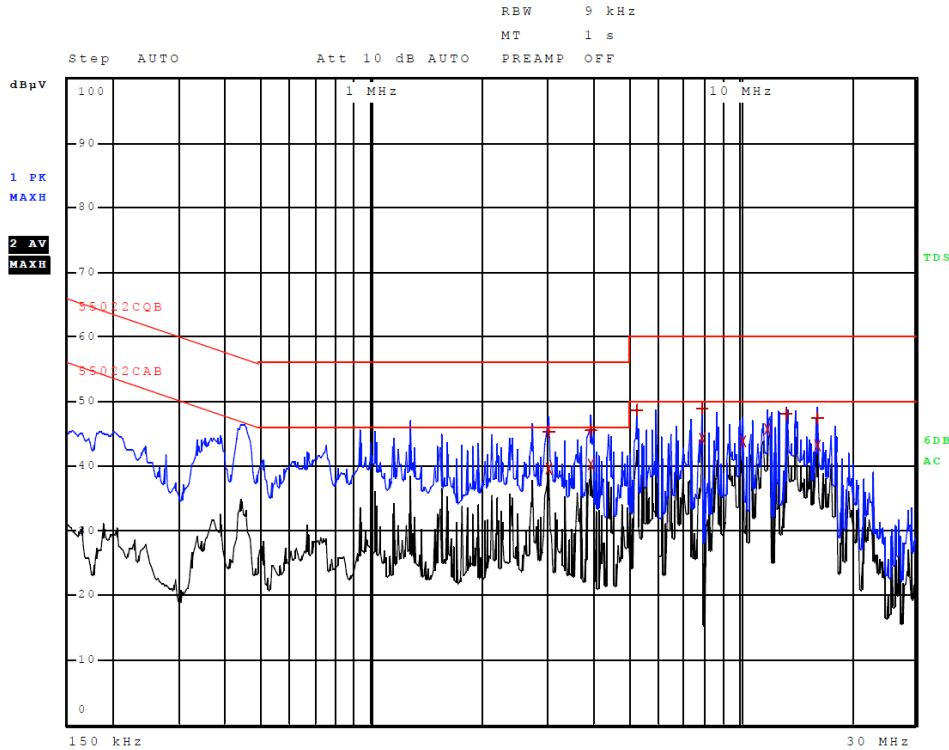

Figure 3 AC Line Conducted Emissions Line 1 Configuration #2

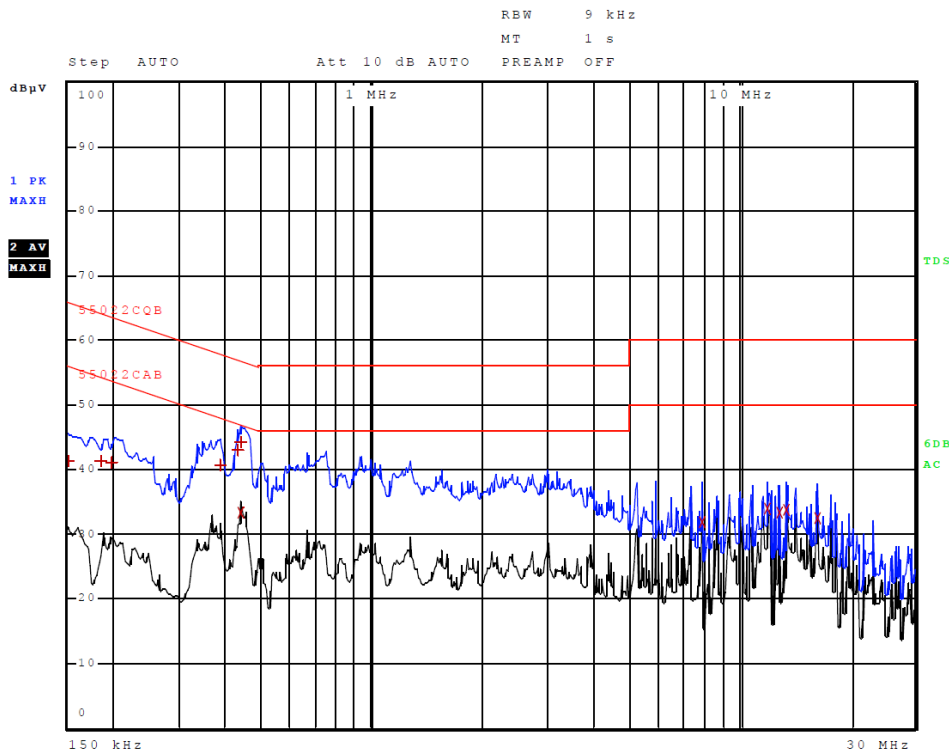

Figure 4 AC Line Conducted Emissions Line 2 Configuration #2

Table 5 AC Line Conducted Emissions Data (Highest Emissions Line L1) Configuration #2

Trace	Frequency	Level (dBµV)	Detector	Delta Limit/dB
1	3.038000000 MHz	45.17	Quasi Peak	-10.83
2	3.038000000 MHz	39.64	Average	-6.36
1	3.954000000 MHz	45.50	Quasi Peak	-10.50
2	3.954000000 MHz	40.18	Average	-5.82
1	5.236000000 MHz	48.61	Quasi Peak	-11.39
1	7.924000000 MHz	48.87	Quasi Peak	-11.13
2	7.924000000 MHz	44.28	Average	-5.72
2	10.244000000 MHz	43.77	Average	-6.23
2	11.892000000 MHz	45.71	Average	-4.29
1	13.420000000 MHz	47.95	Quasi Peak	-12.05
1	16.228000000 MHz	47.43	Quasi Peak	-12.57
2	16.228000000 MHz	43.13	Average	-6.87

Other emissions present had amplitudes at least 20 dB below the limit.

Table 6 AC Line Conducted Emissions Data (Highest Emissions Line L2) Configuration #2

Trace	Frequency	Level (dBµV)	Detector	Delta Limit/dB
1	150.000000000 kHz	41.37	Quasi Peak	-24.63
1	186.000000000 kHz	41.20	Quasi Peak	-23.02
1	198.000000000 kHz	40.99	Quasi Peak	-22.70
1	386.000000000 kHz	40.66	Quasi Peak	-17.49
1	430.000000000 kHz	42.98	Quasi Peak	-14.28
2	438.000000000 kHz	33.25	Average	-13.85
1	438.000000000 kHz	44.30	Quasi Peak	-12.80
2	7.924000000 MHz	31.82	Average	-18.18
2	11.892000000 MHz	34.01	Average	-15.99
2	12.808000000 MHz	33.38	Average	-16.62
2	13.420000000 MHz	33.67	Average	-16.33
2	16.228000000 MHz	32.51	Average	-17.49

Other emissions present had amplitudes at least 20 dB below the limit.

Summary of Results for AC Line Conducted Emissions

The EUT test system demonstrated compliance with the AC Line conducted emissions requirements of 47CFR 15.207, RSS-247 Issue 1 and RSS-GEN. The worst-case EUT configuration demonstrated a minimum margin of -4.2 dB below the limit. Measurements were taken using the peak, quasi peak, and average, measurement function for each emissions amplitude and were below the limits stated in the specification. Other emissions were present with recorded data representing worst-case amplitudes.

General Radiated Emissions Procedure

The EUT was arranged in typical equipment configurations and operated through all available modes with worst-case data recorded. Preliminary testing was performed in a screen room with the EUT positioned 1 meter from the FSM. Radiated emissions measurements were performed to identify the frequencies, which produced the highest emissions. Each radiated emission was then maximized at the OATS location before final radiated emissions measurements were performed. Final data was taken with the EUT located at the OATS at a distance of 3 meters between the EUT and the receiving antenna. The frequency spectrum from 9 kHz to 25,000 MHz was searched for general radiated emissions. Measured emission levels were maximized by EUT placement on the table, rotating the turntable through 360 degrees, varying the antenna height between 1 and 4 meters above the ground plane and changing antenna position between horizontal and vertical polarization. Antennas used were Loop from 9 kHz to 30 MHz, Broadband Biconical from 30 to 200 MHz, Biconilog from 30 to 1000 MHz, Log Periodic from 200 MHz to 1 GHz and or Double Ridge or pyramidal horns from 1 GHz to 25 GHz, notch filters, and appropriate amplifiers were used during investigation and testing.

Table 7 General Radiated Emissions from EUT Data (Highest Emissions)

Frequency in MHz	Horizontal Peak (dBµV/m)	Horizontal Quasi-Peak (dBµV/m)	Horizontal Average (dBµV/m)	Vertical Peak (dBµV/m)	Vertical Quasi-Peak (dBµV/m)	Vertical Average (dBµV/m)	Limit @ 3m (dBµV/m)
47.8	35.1	29.7	N/A	38.1	33.8	N/A	40.0
50.4	35.6	29.0	N/A	38.0	33.2	N/A	40.0
51.8	31.9	24.9	N/A	38.9	33.8	N/A	40.0
64.8	37.9	28.9	N/A	38.6	28.5	N/A	40.0
85.3	33.7	28.6	N/A	36.6	32.8	N/A	40.0
85.5	30.5	26.1	N/A	37.7	32.9	N/A	40.0
86.0	34.5	30.4	N/A	37.4	33.3	N/A	40.0
141.2	36.6	26.9	N/A	33.6	30.5	N/A	40.0
145.3	38.8	30.4	N/A	35.3	32.2	N/A	40.0
155.6	32.4	21.0	N/A	25.9	21.2	N/A	40.0
159.6	34.6	21.9	N/A	29.2	16.6	N/A	40.0
700.0	42.0	40.9	N/A	26.9	22.6	N/A	47.0
875.0	44.8	38.0	N/A	41.4	35.5	N/A	47.0

Other emissions present had amplitudes at least 20 dB below the limit. Peak and Quasi-Peak amplitude emissions are recorded above for frequency range below 1000 MHz. Peak and Average amplitude emissions are recorded above for frequency range above 1000 MHz.

Summary of Results for General Radiated Emissions

The EUT demonstrated compliance with the radiated emissions requirements of 47CFR part 15 and Industry Canada RSS-247 Issue 2 Intentional Radiators. The EUT demonstrated a minimum margin of -6.1 dB below the requirements. Other emissions were present with amplitudes at least 20 dB below the Limits.

Operation in the 2400-2483.5 MHz Frequency Band

Radiated emissions were measured on the Open Area Test Site (OATS) at a three-meter distance. Production equipment design of the EUT provides no connection to antenna ports. Radiated emissions measurements were performed on the production design test sample as documented in this report. Testing procedures defined in publications ANSI C63.10-2013, KDB 558074 D01 DTS Meas Guidance v04, and KDB 662911 D01 Multiple Transmitter Output v02r01 were utilized during compliance testing. The EUT was placed on a turntable elevated as required above the ground plane at a distance of 3 meters from the FSM antenna located on the OATS. The peak and quasi-peak amplitude of the frequencies below 1000 MHz were measured using a spectrum analyzer / EMC receiver. The peak and average amplitude of emissions above 1000 MHz were measured using a spectrum analyzer / EMC receiver. Emissions data was recorded from the measurement results. Data presented reflects measurement result corrected to account for measurement system gains and losses. A second test sample was provided for testing. This sample replaced the integral antenna with 50-ohm connectors. Antenna conducted measurements were made on test sample #2 at the antenna port RF connections. Data presented reflects measurement result corrected to account for measurement system gains and losses. Plots were made of transmitter performance for reference purposes. Refer to figures five through forty-four for plots of antenna port conducted performance.

1. The transmitter's average power was measured as specified in KDB's 558074 9.2.2.2, 9.2.3.2, and 662911 D01 (measure and sum technique)
2. Emission DTS Bandwidth was measured as specified in KDB 558074 paragraph 8.
3. Average Power Spectral Density was measured as specified in KDB 558074 10.3.
4. Unwanted Radiated Emissions were measured as specified in KDB 558074 paragraph 11 and specified in ANSI C63-10 at a 3-meters distance located on the OATS.
5. Radiated Emissions Levels in restricted bands were measured as specified in KDB 558074 paragraph 12 and ANSI C63-10 at a 3-meters distance located on the OATS.
6. Band-Edge measurements were performed as specified in KDB 558074 paragraph 13 and ANSI C63-10.

Directional correlated antenna calculation (antenna gain 12dBi, and 2 chains). Per KDB 662911 D01 Multiple Transmitter Output v02r01, the directional gain for correlated emissions in-band may be calculated using the following formula:

$$\text{Directional gain} = G_{\text{ANT}} + 10 \log (N_{\text{ANT}}) \text{ dBi}$$

$$\text{Directional gain} = 12 + 10 \log (2) \text{ dBi} = 15 \text{ dBi}$$

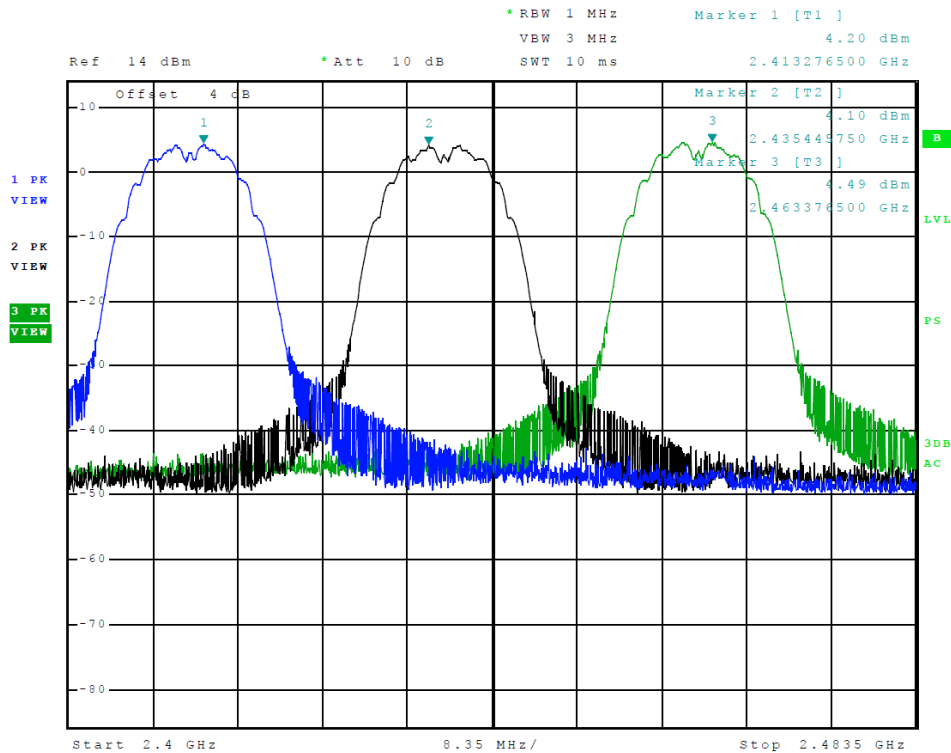

Figure 5 Plot of Transmitter Emissions (Across Operational Band 802.11b, Chain 0)

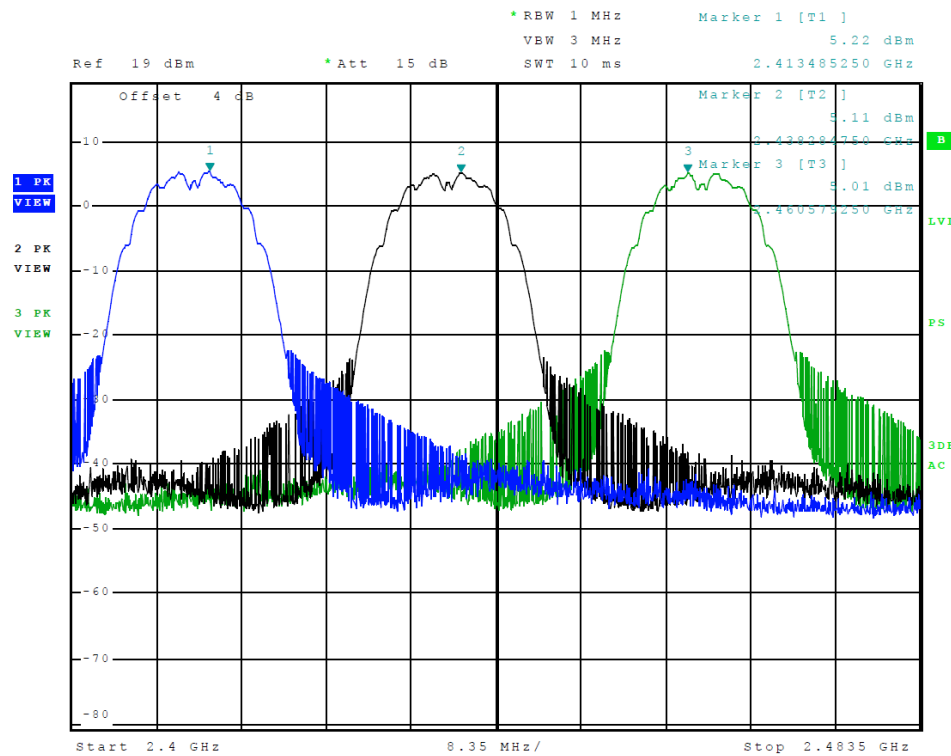

Figure 6 Plot of Transmitter Emissions (Across Operational Band 802.11b, Chain 1)

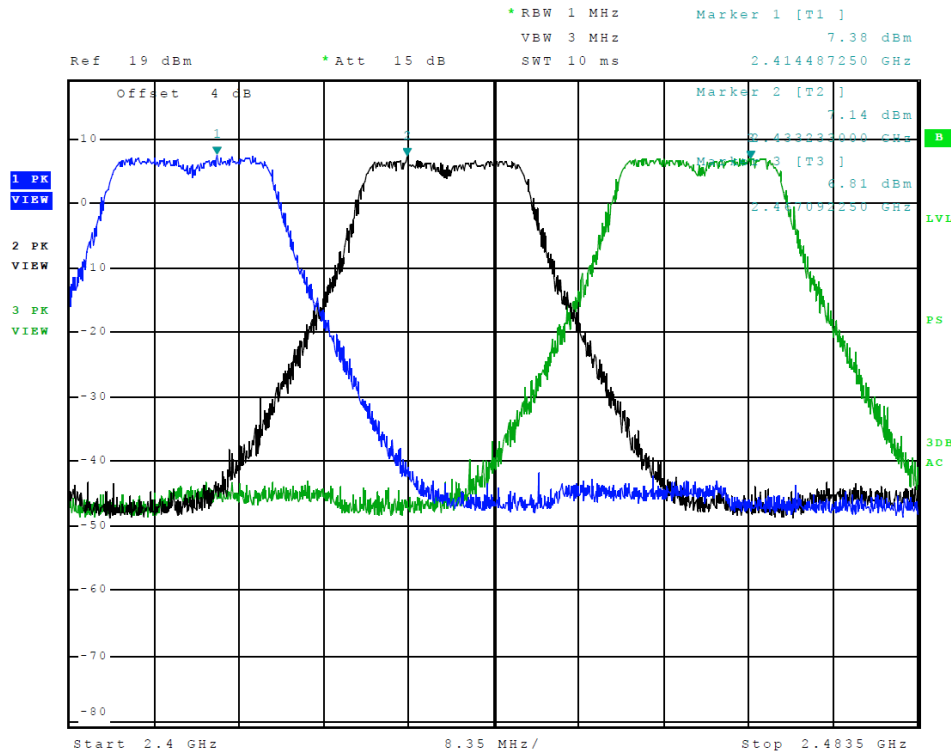

Figure 7 Plot of Transmitter Emissions (Across Operational Band, 802.11g, Chain 0)

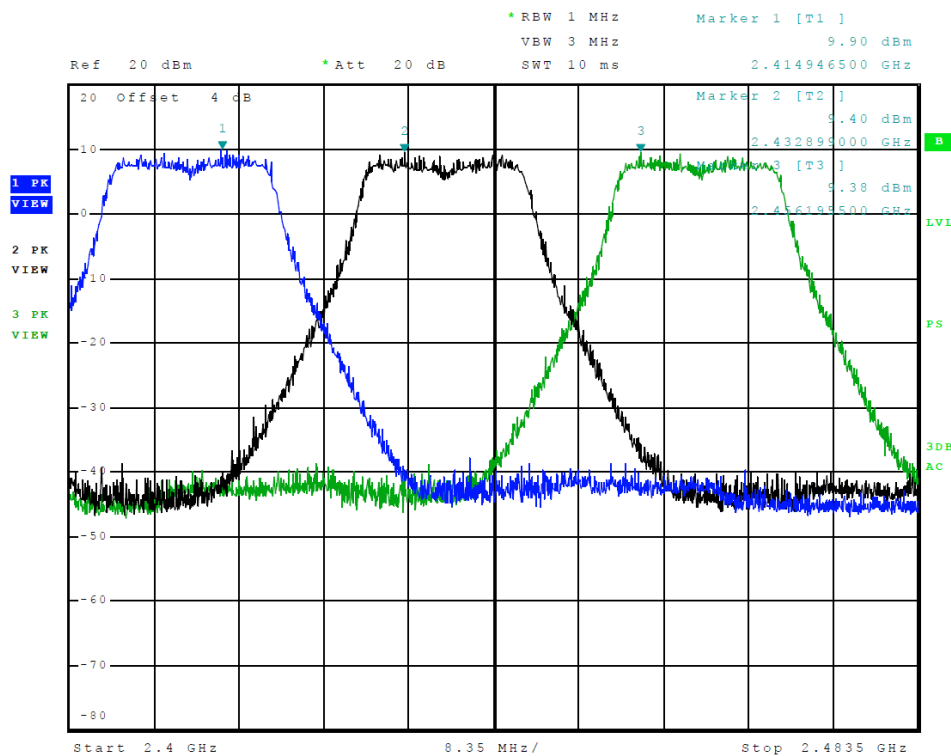

Figure 8 Plot of Transmitter Emissions (Across Operational Band, 802.11g, Chain 1)

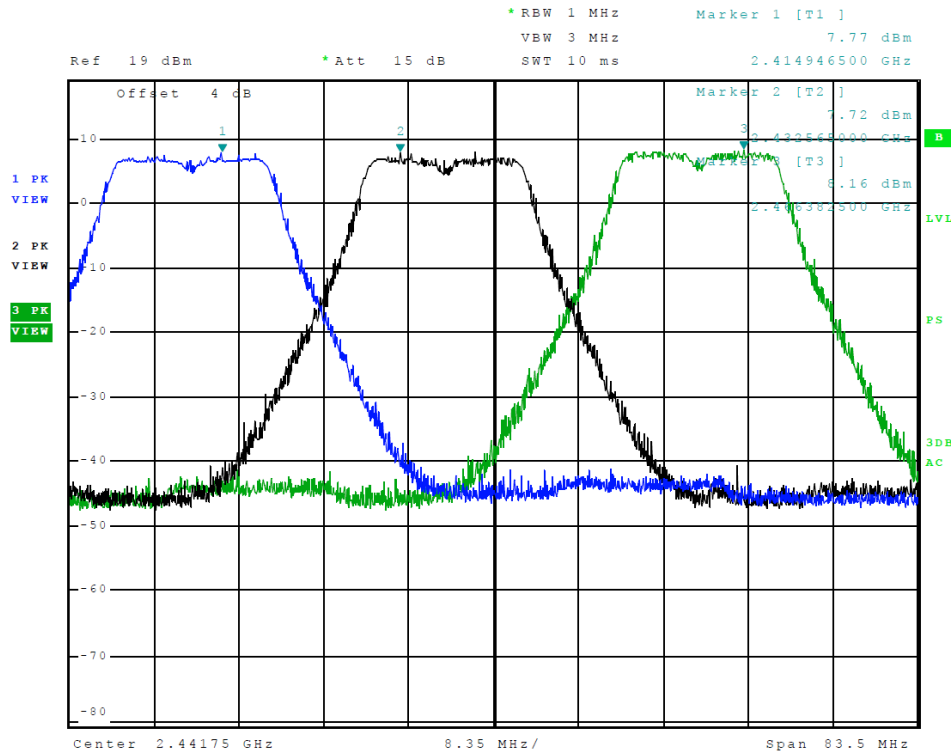

Figure 9 Plot of Transmitter Emissions (Across Operational Band, 802.11n (20), Chain 0)

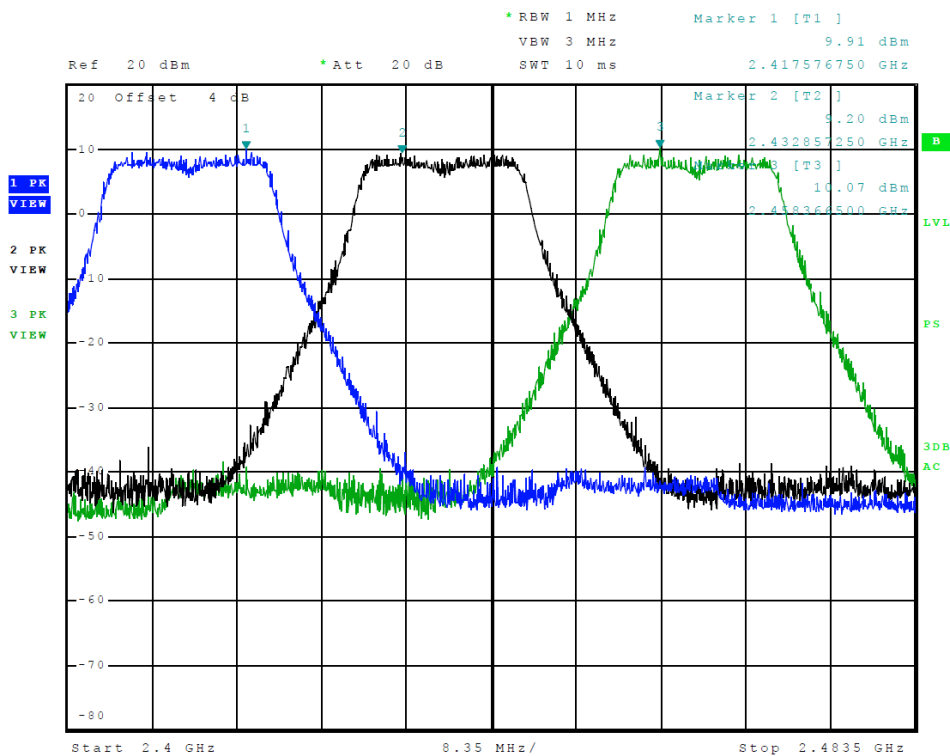

Figure 10 Plot of Transmitter Emissions (Across Operational Band, 802.11n (20), Chain 1)

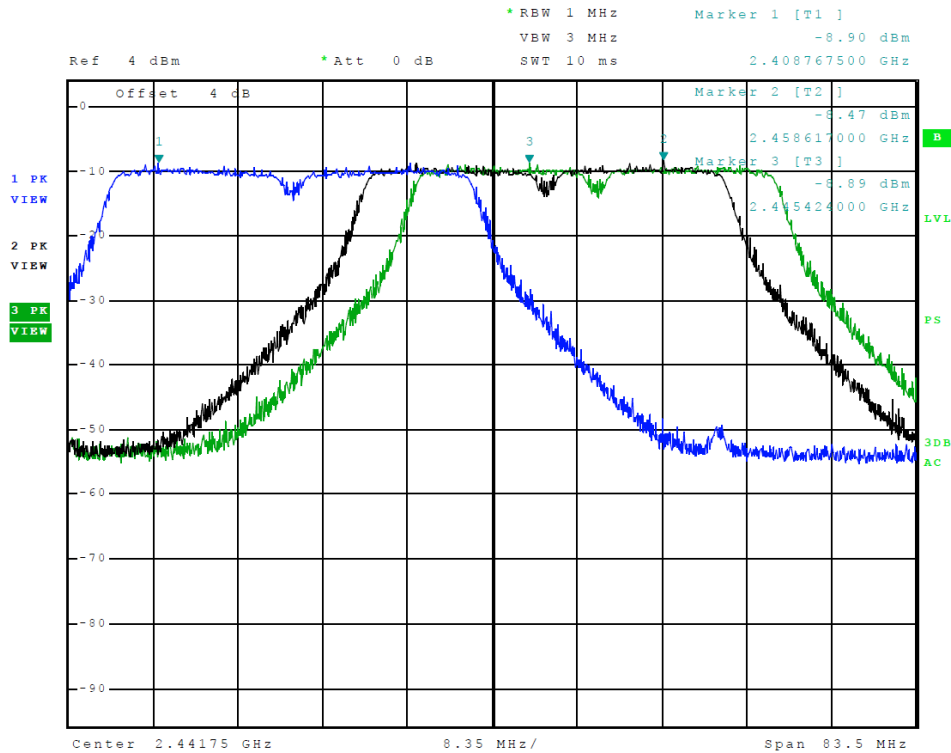

Figure 11 Plot of Transmitter Emissions (Across Operational Band, 802.11n (40), Chain 0)

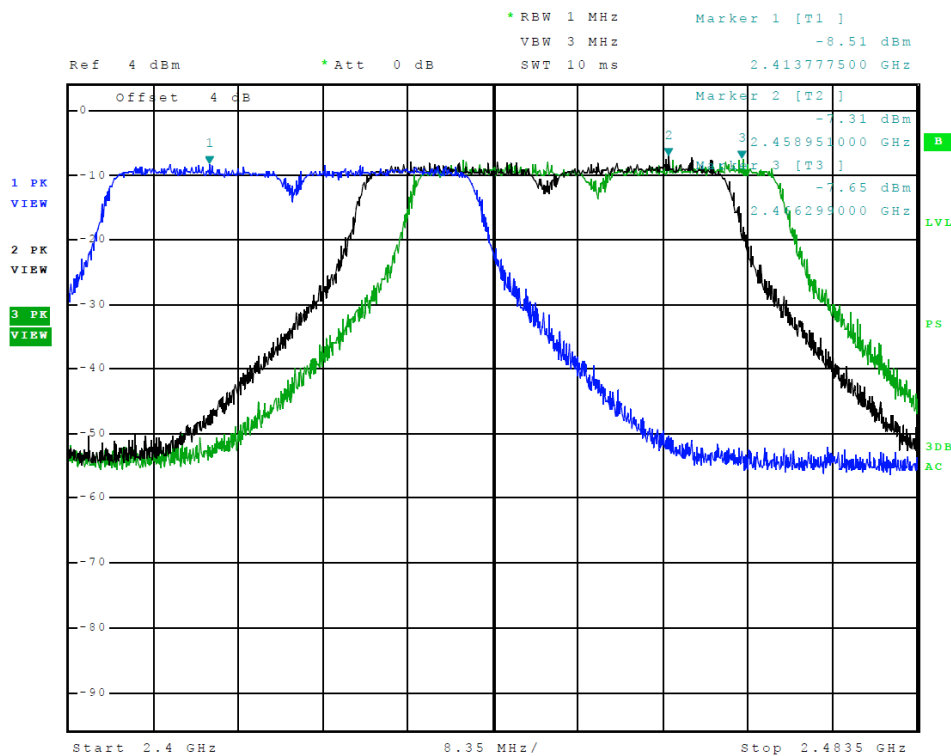

Figure 12 Plot of Transmitter Emissions (Across Operational Band, 802.11n (40), Chain 1)

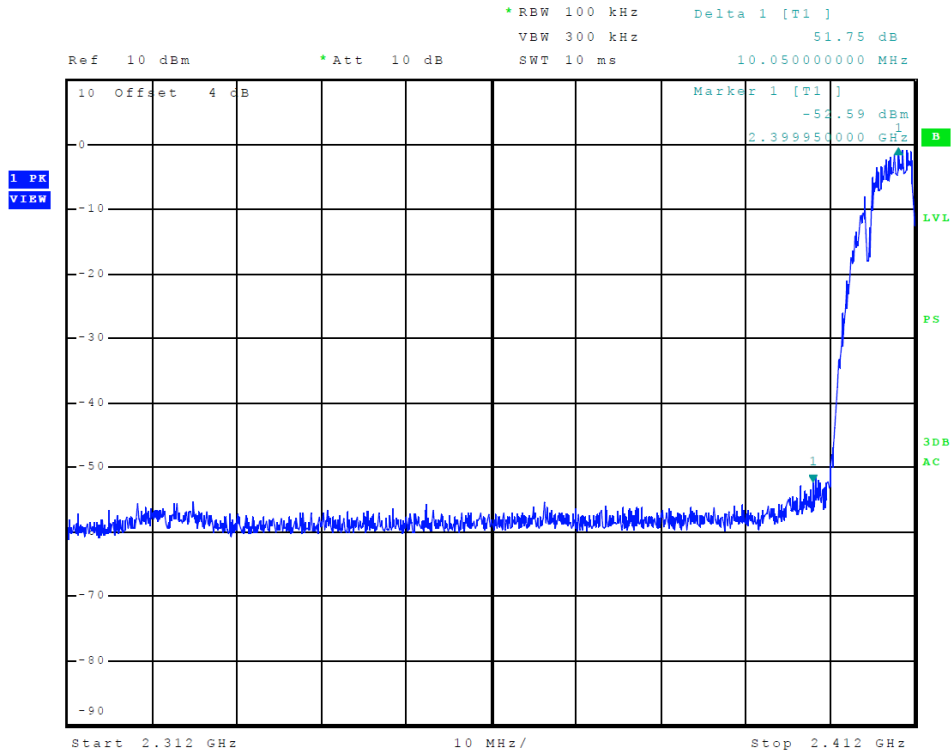

Figure 13 Plot of Transmitter Low Band Edge (802.11b, Chain 0)

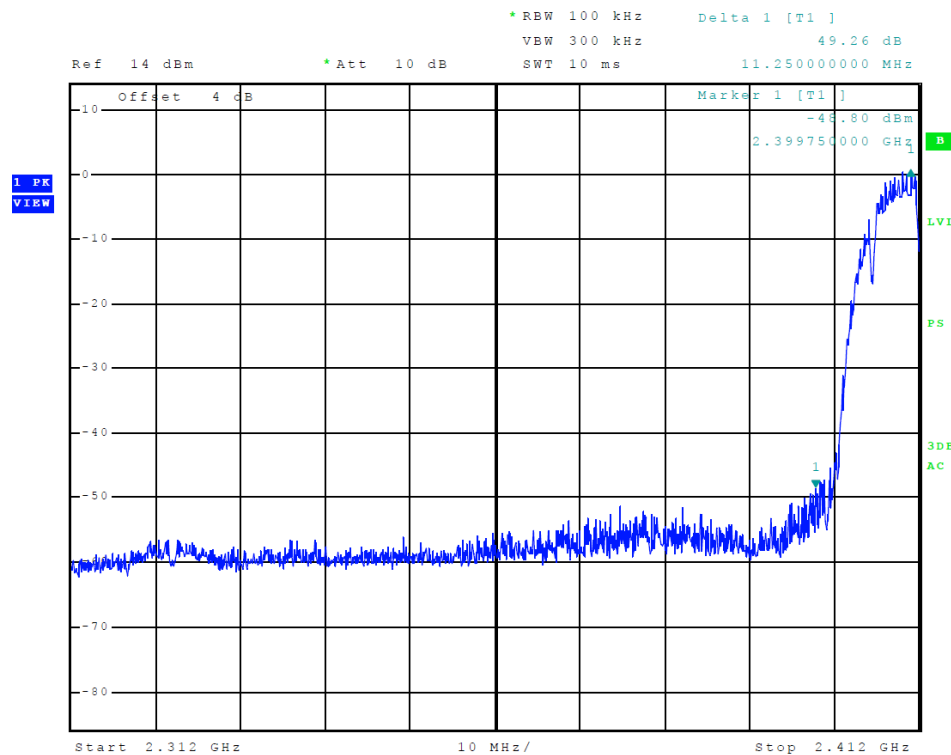

Figure 14 Plot of Transmitter Low Band Edge (802.11b, Chain 1)

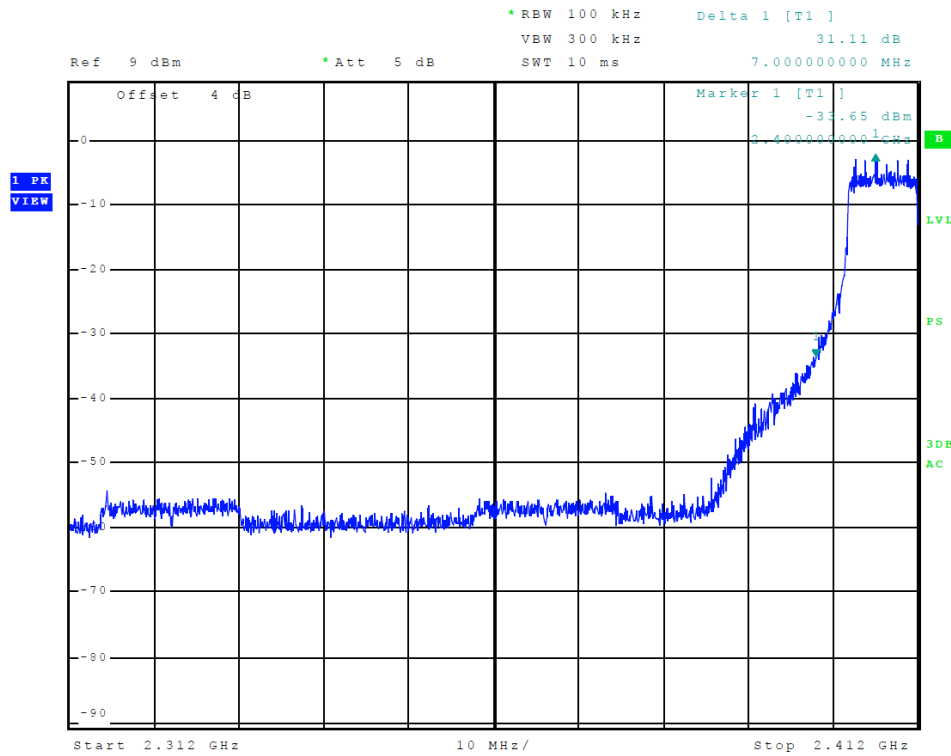

Figure 15 Plot of Transmitter Low Band Edge (802.11g, Chain 0)

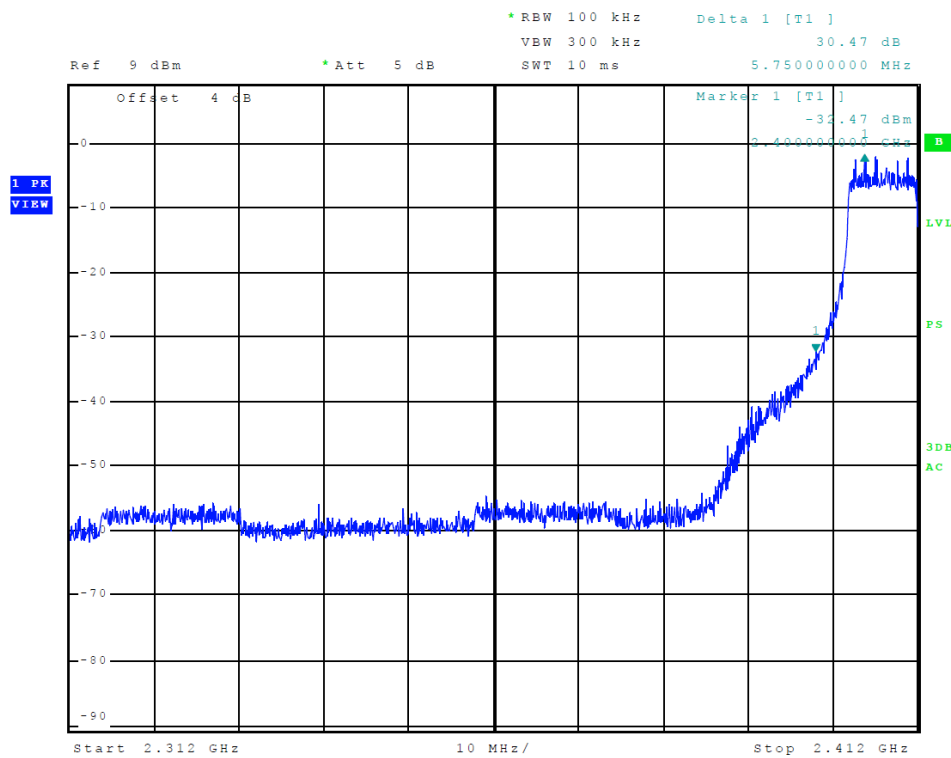

Figure 16 Plot of Transmitter Low Band Edge (802.11g, Chain 1)

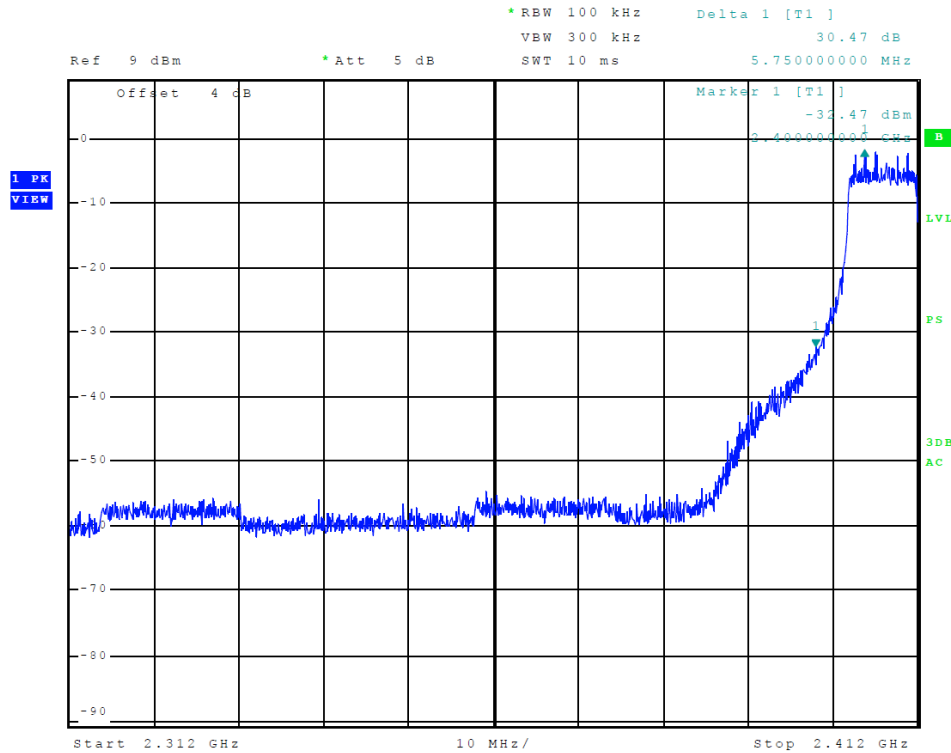

Figure 17 Plot of Transmitter Low Band Edge (802.11n (20), Chain 0)

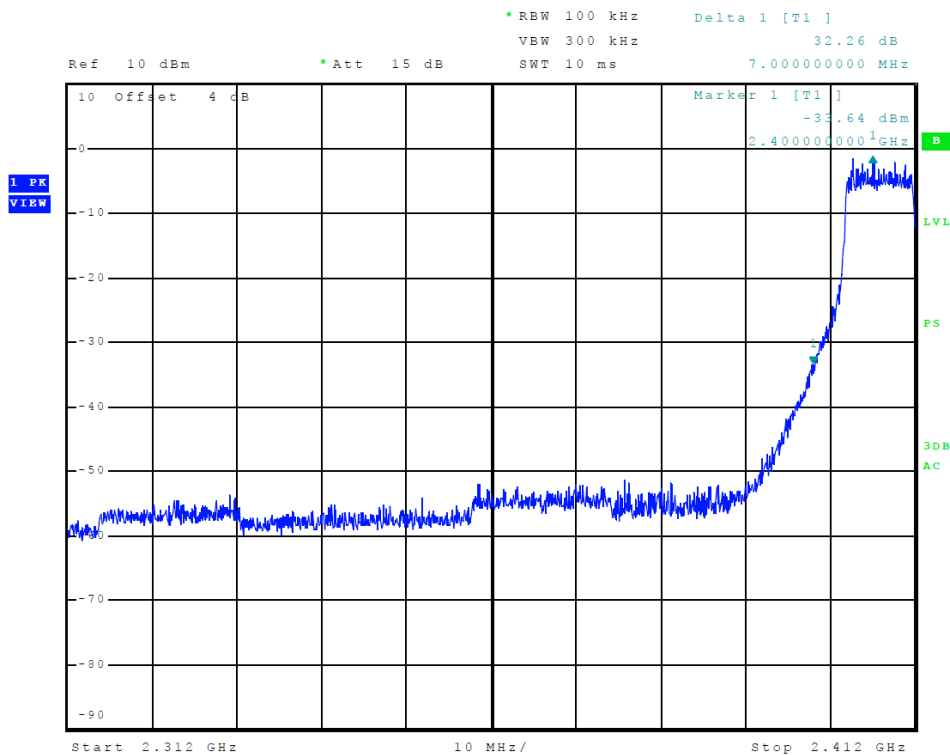

Figure 18 Plot of Transmitter Low Band Edge (802.11n (20), Chain 1)

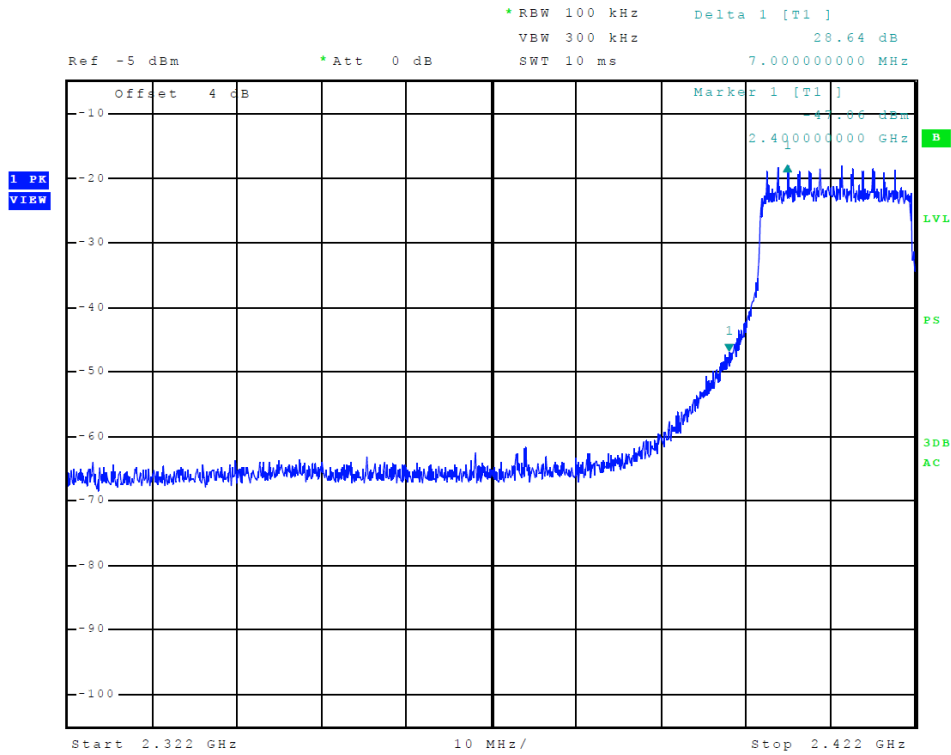

Figure 19 Plot of Transmitter Low Band Edge (802.11n (40), Chain 0)

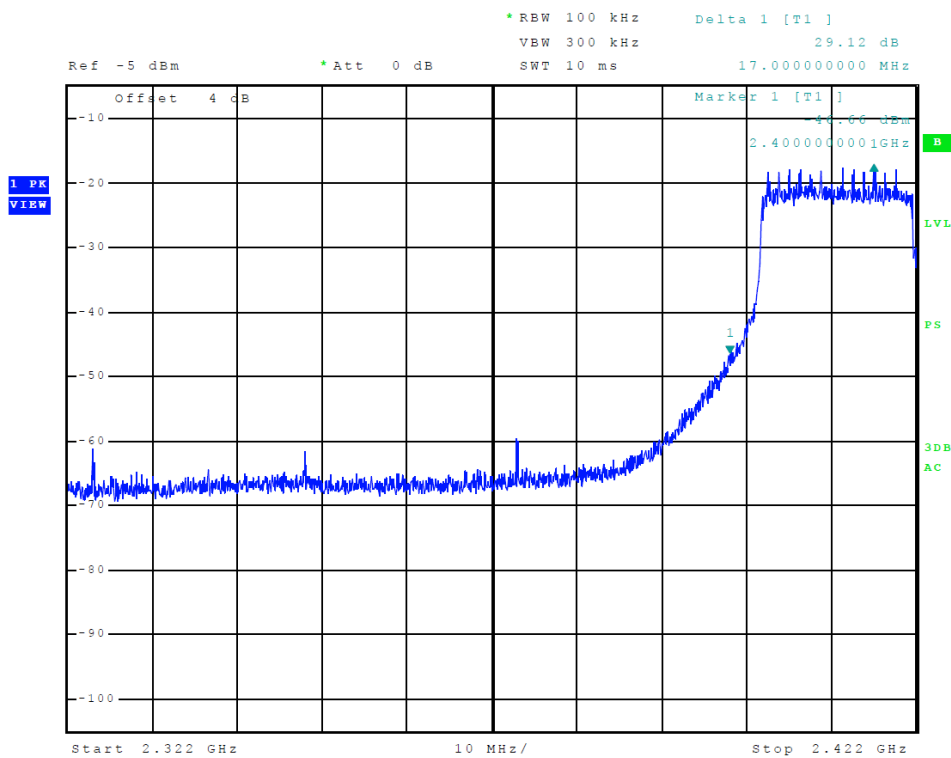

Figure 20 Plot of Transmitter Low Band Edge (802.11n (40), Chain 1)

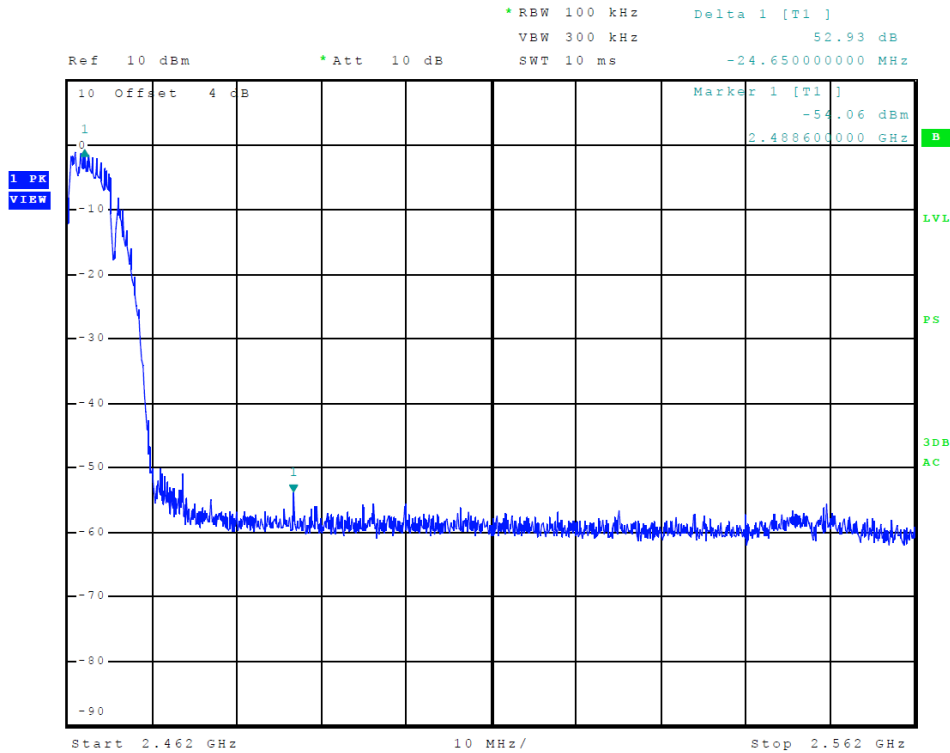

Figure 21 Plot of Transmitter High Band Edge (802.11b, Chain 0)

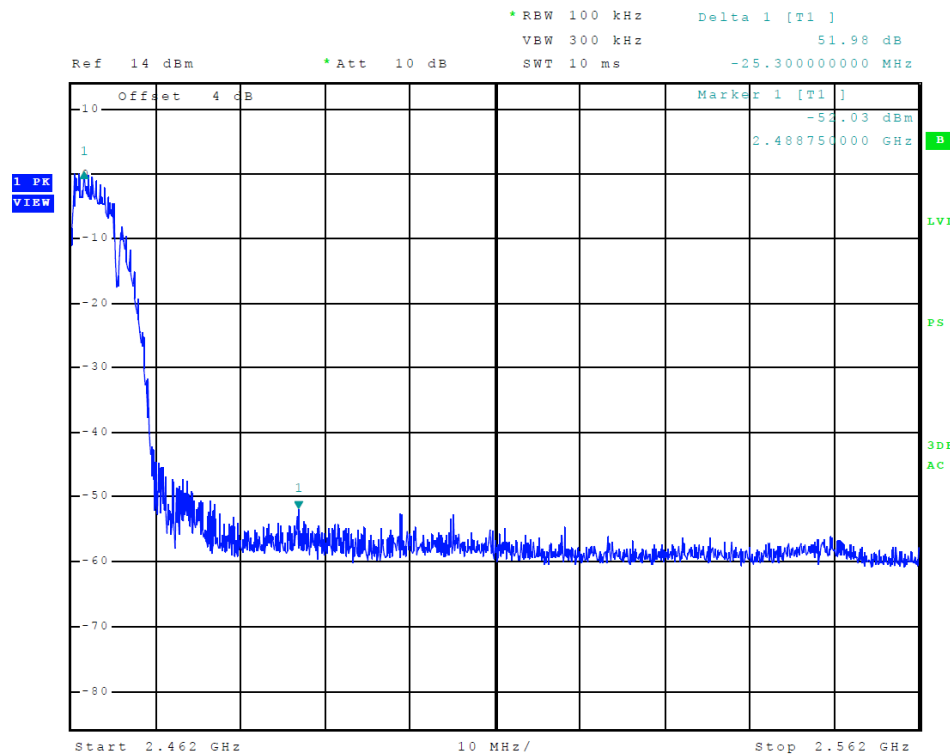

Figure 22 Plot of Transmitter High Band Edge (802.11b, Chain 1)

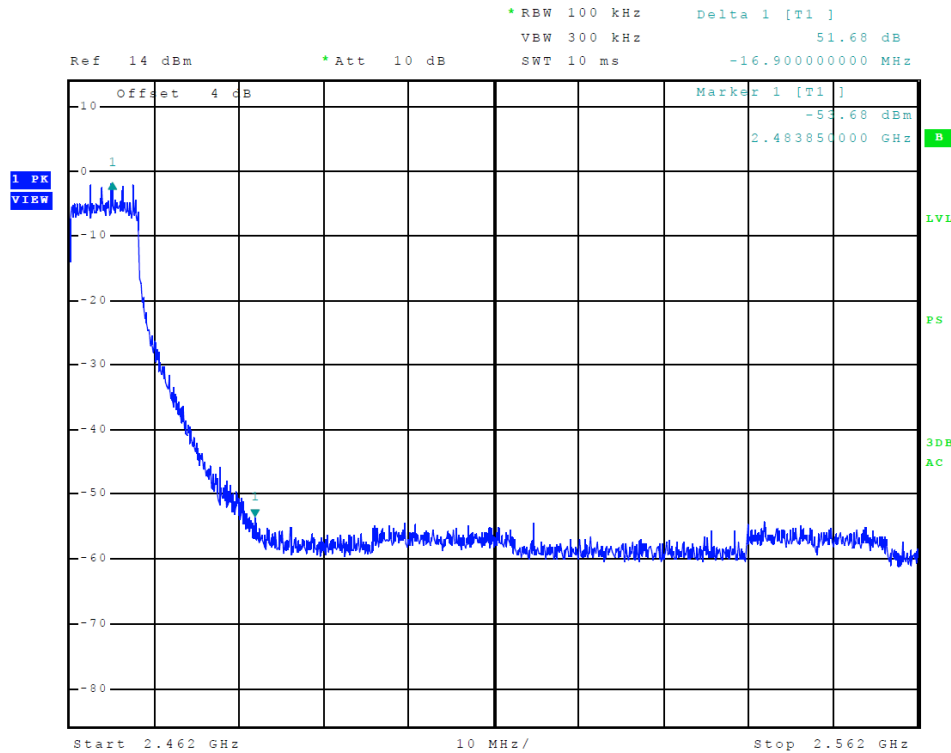

Figure 23 Plot of Transmitter High Band Edge (802.11g, Chain 0)

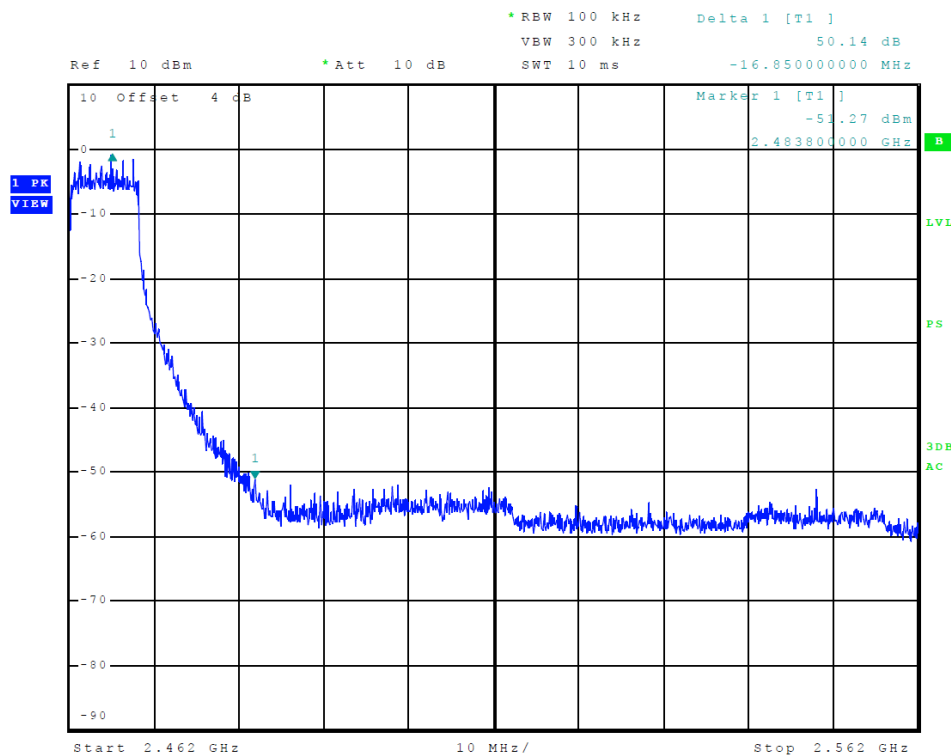

Figure 24 Plot of Transmitter High Band Edge (802.11g, Chain 1)

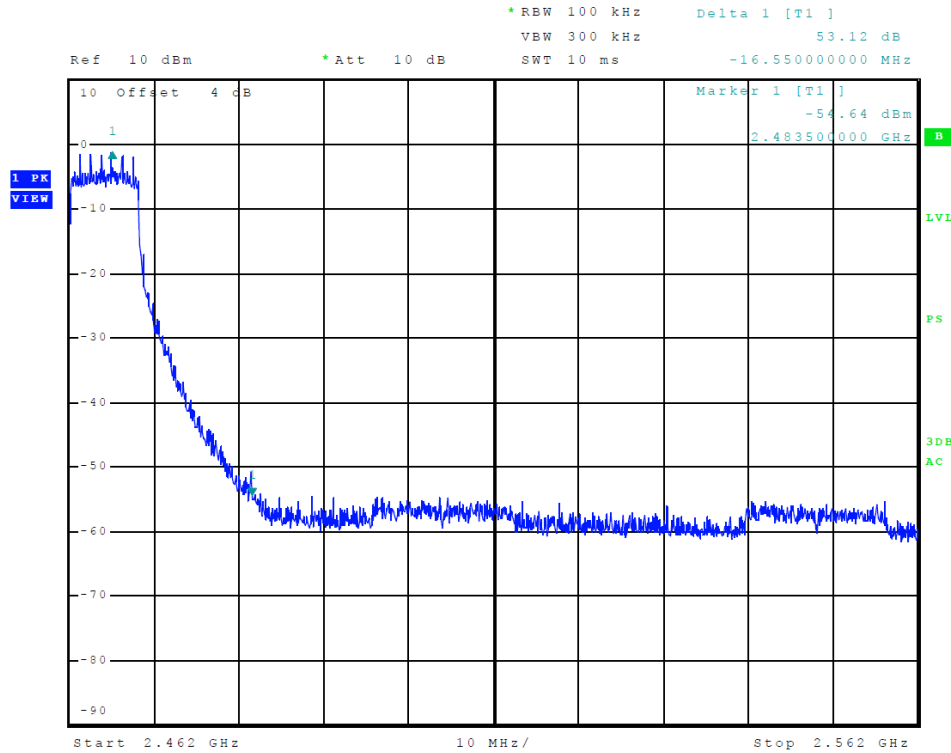

Figure 25 Plot of Transmitter High Band Edge (802.11n (20), Chain 0)

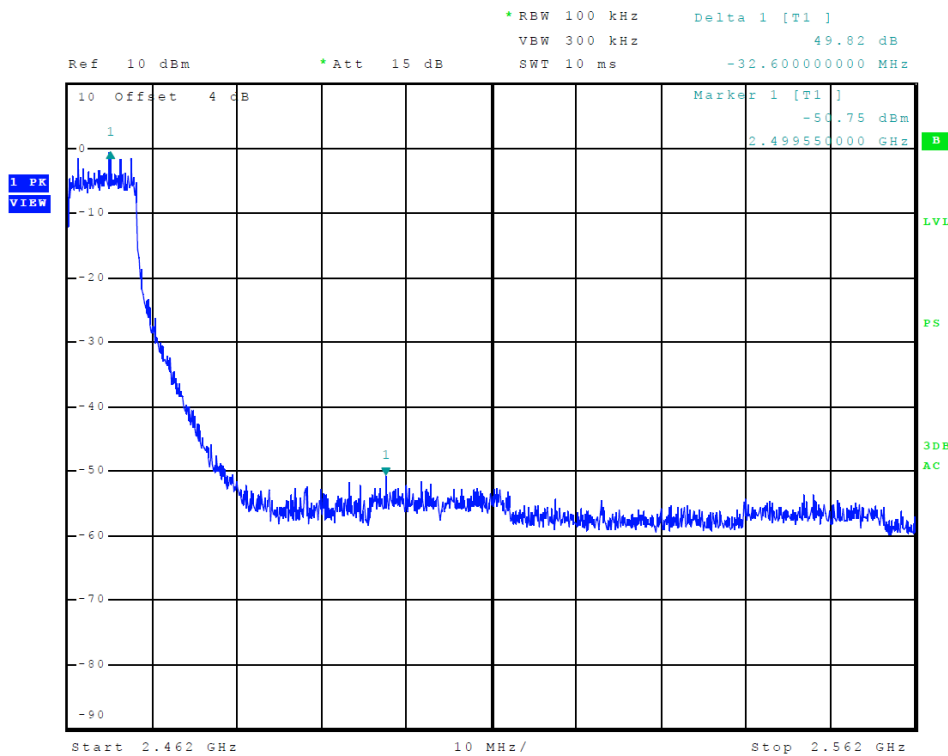

Figure 26 Plot of Transmitter High Band Edge (802.11n (20), Chain 1)

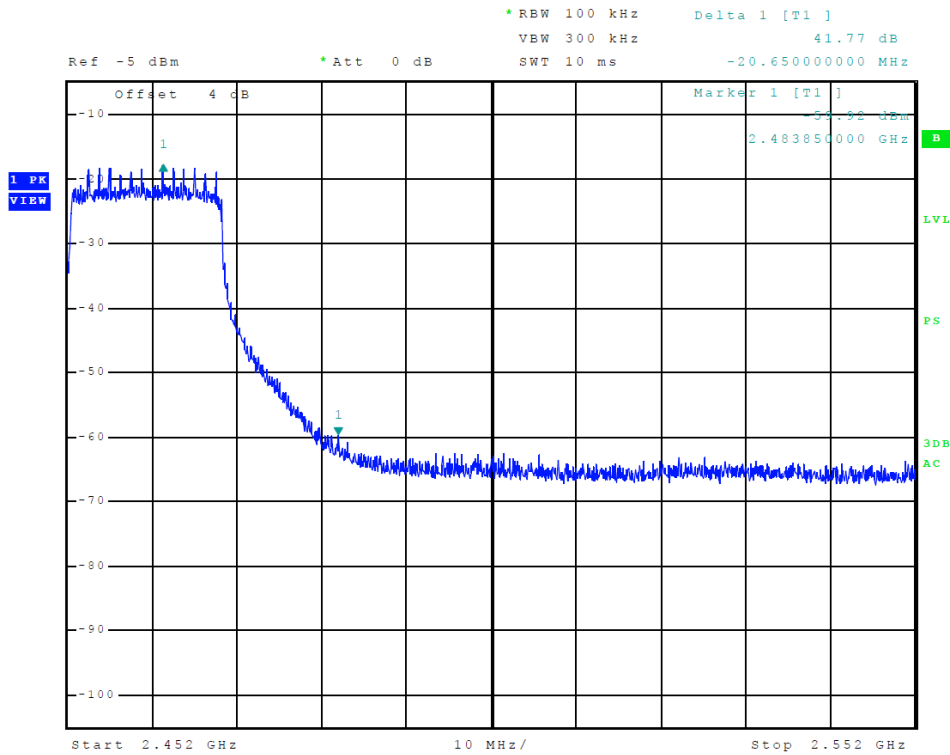

Figure 27 Plot of Transmitter High Band Edge (802.11n (40), Chain 0)

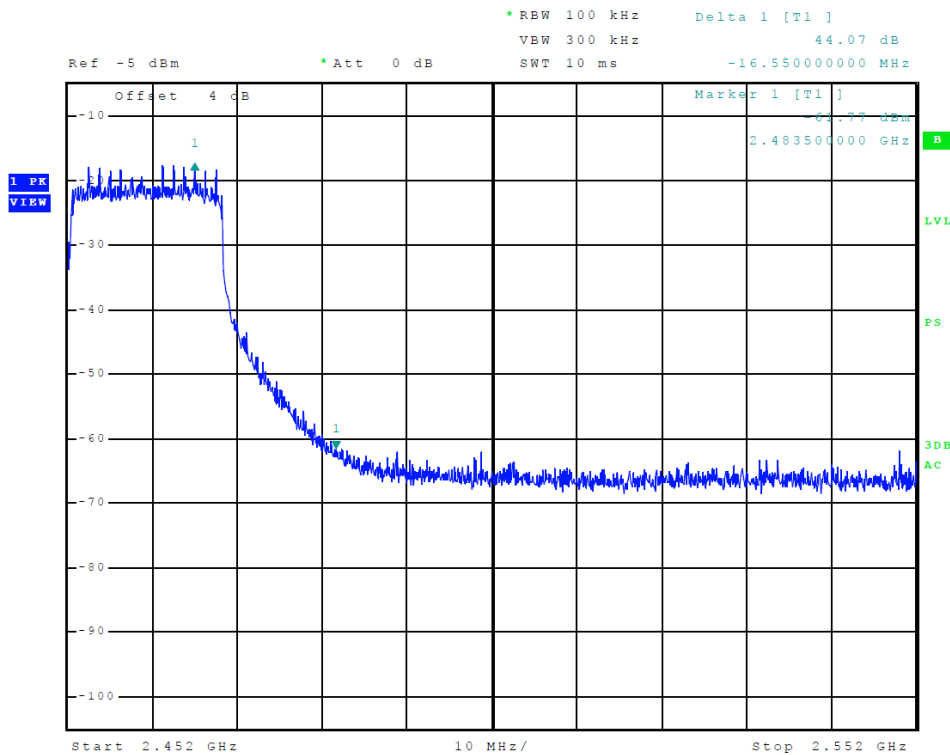

Figure 28 Plot of Transmitter High Band Edge (802.11n (40), Chain 1)

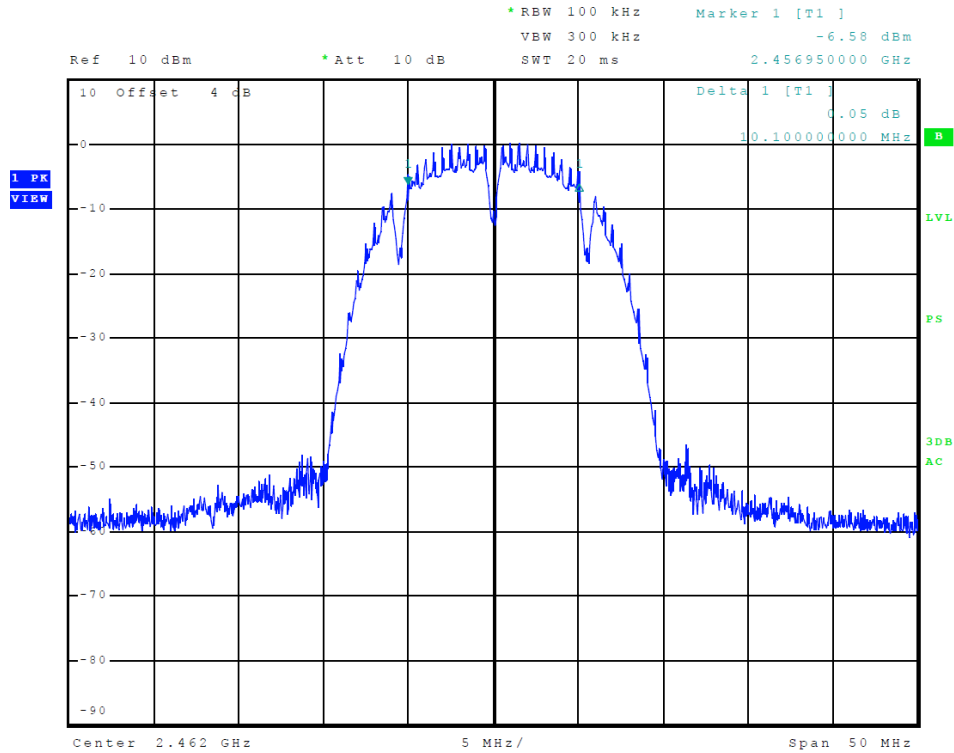

Figure 29 Plot of Transmitter 6-dB Occupied Band Width (802.11b, Chain 0)

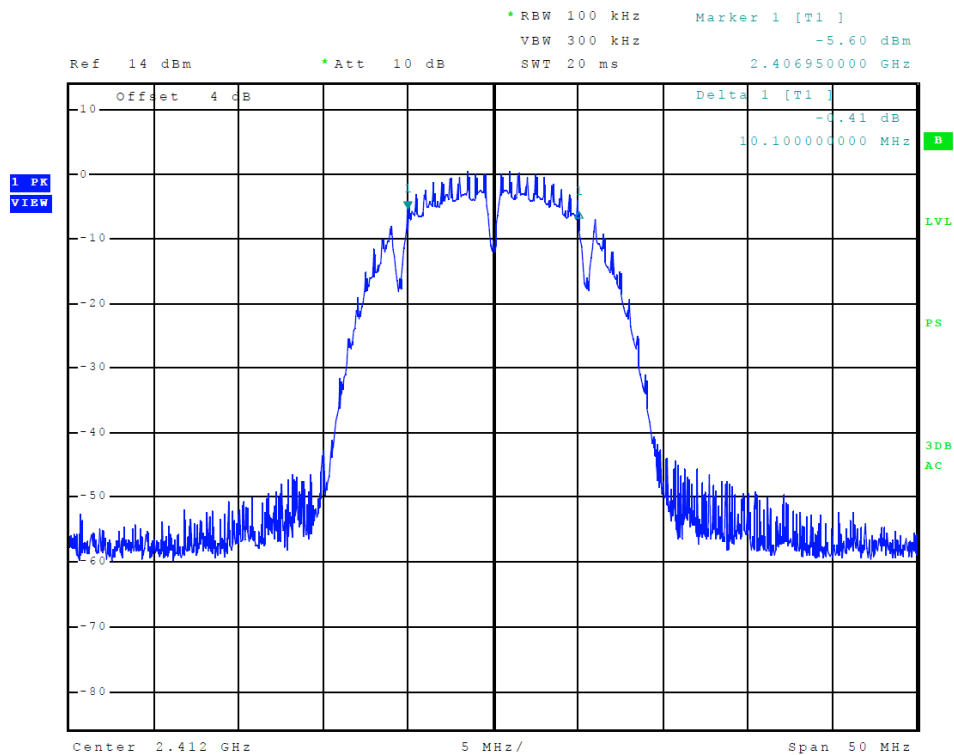

Figure 30 Plot of Transmitter 6-dB Occupied Band Width (802.11b, Chain 1)

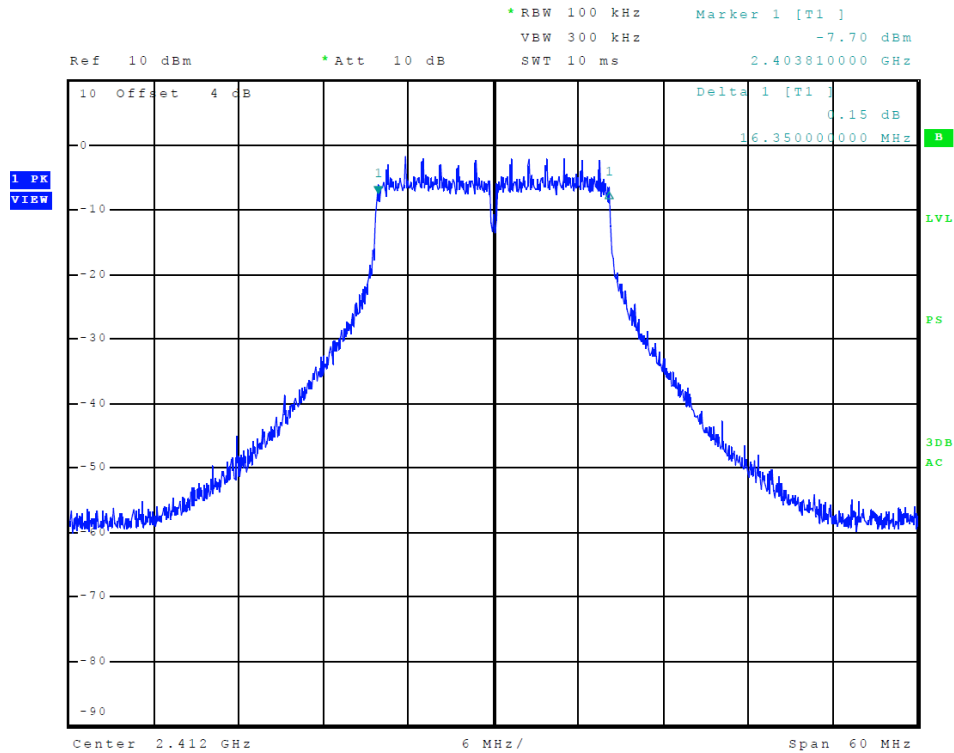

Figure 31 Plot of Transmitter 6-dB Occupied Band Width (802.11g, Chain 0)

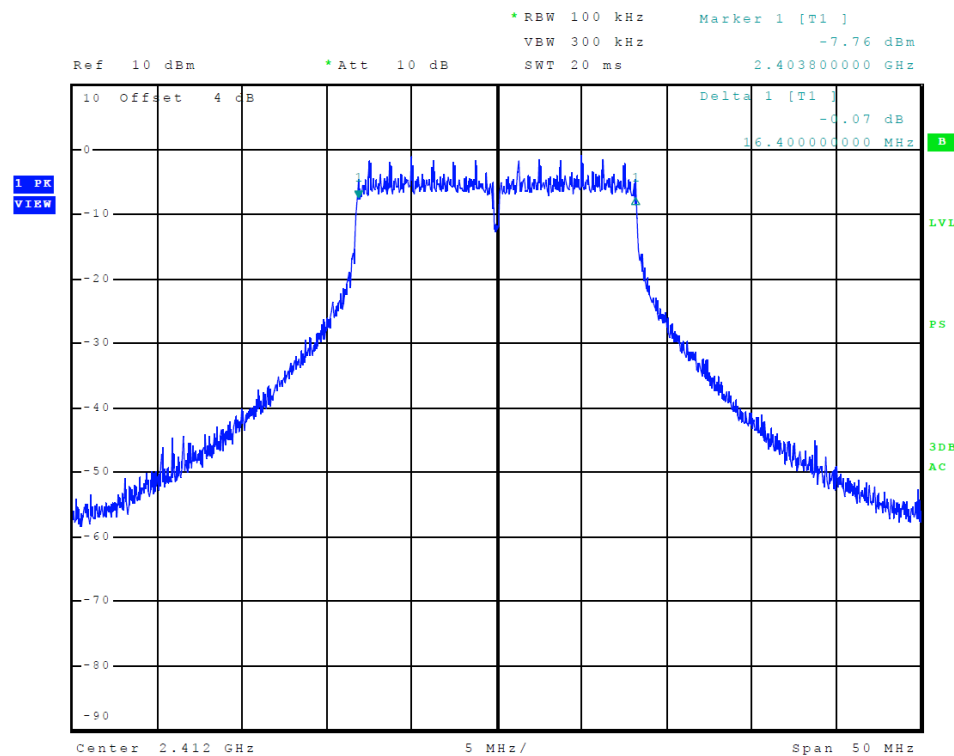

Figure 32 Plot of Transmitter 6-dB Occupied Band Width (802.11g, Chain 1)

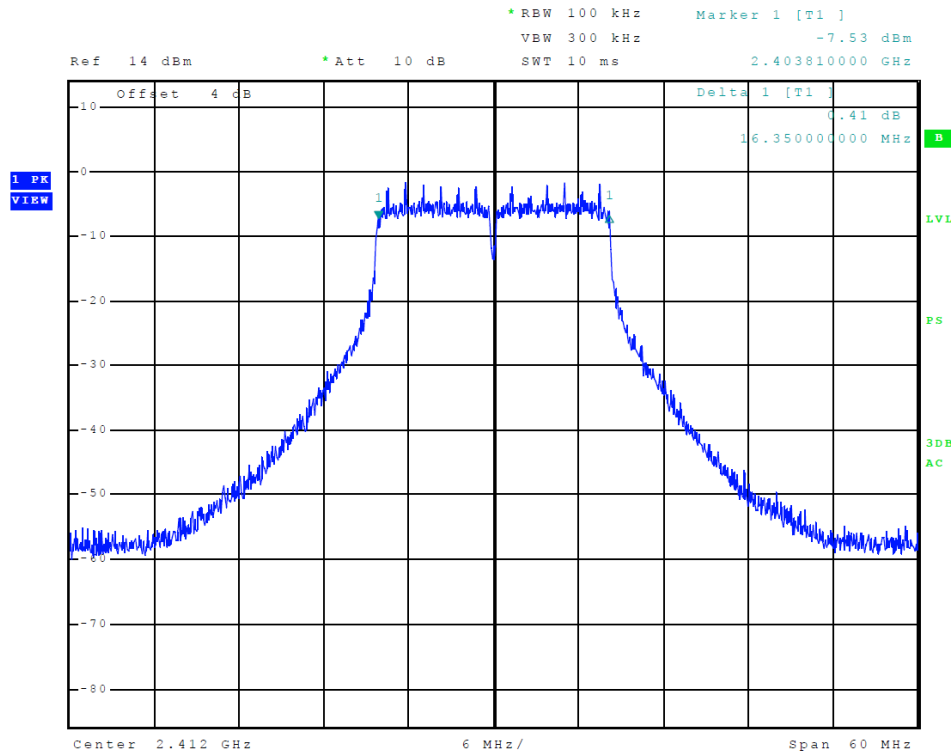

Figure 33 Plot of Transmitter 6-dB Occupied Band Width (802.11n (20), Chain 0)

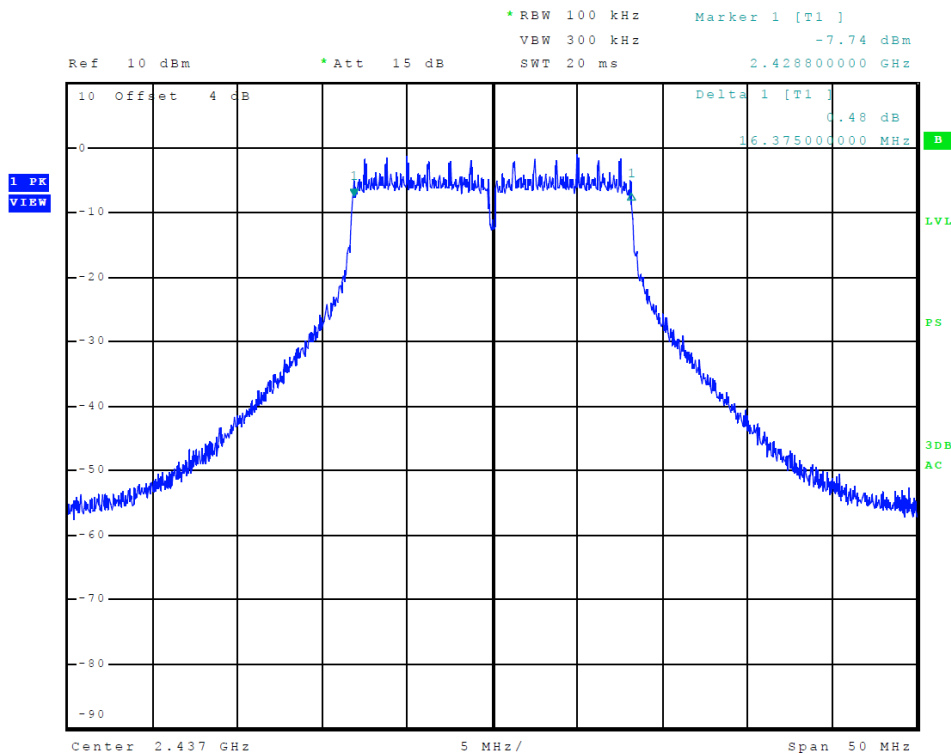

Figure 34 Plot of Transmitter 6-dB Occupied Band Width (802.11n (20), Chain 1)

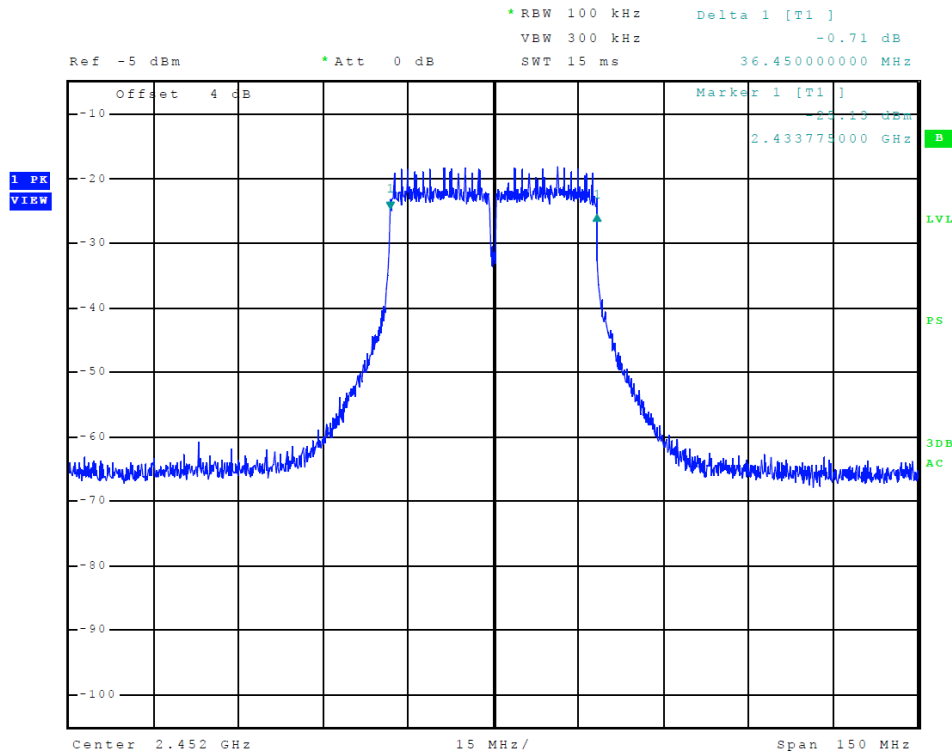

Figure 35 Plot of Transmitter 6-dB Occupied Band Width (802.11n (40), Chain 0)

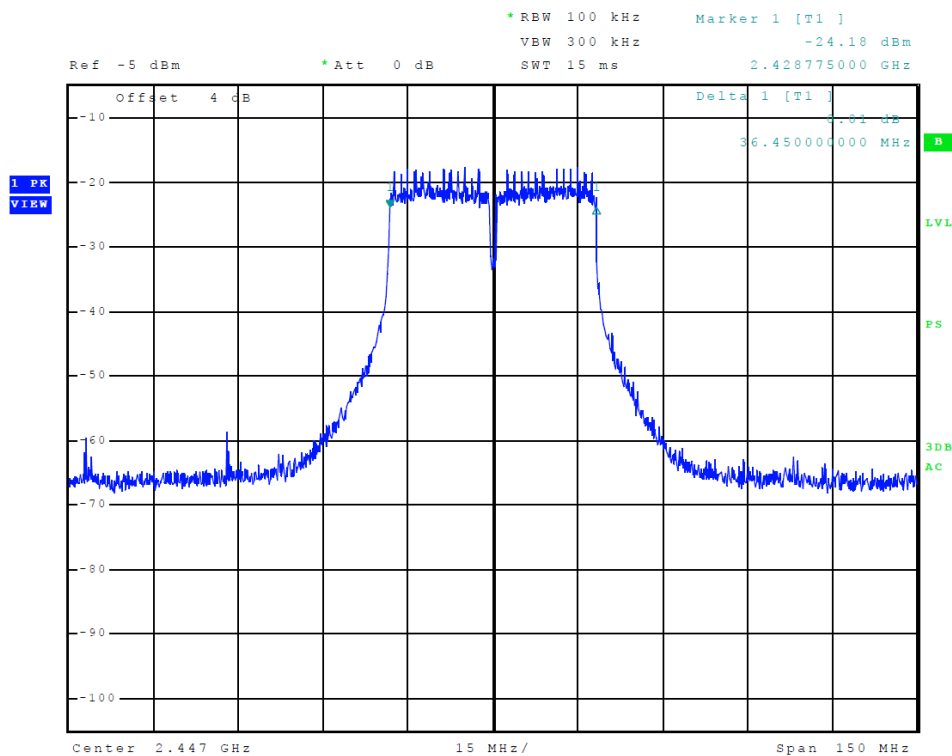

Figure 36 Plot of Transmitter 6-dB Occupied Band Width (802.11n (40), Chain 1)

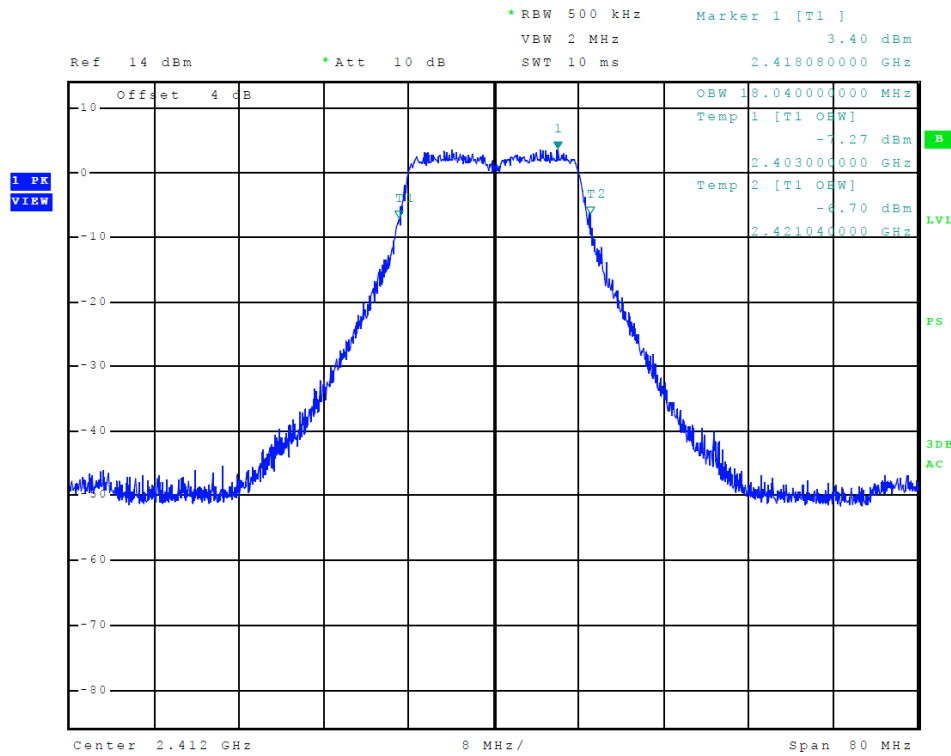

Figure 39 Plot of Transmitter 99% Occupied Band Width (802.11g, Chain 0)

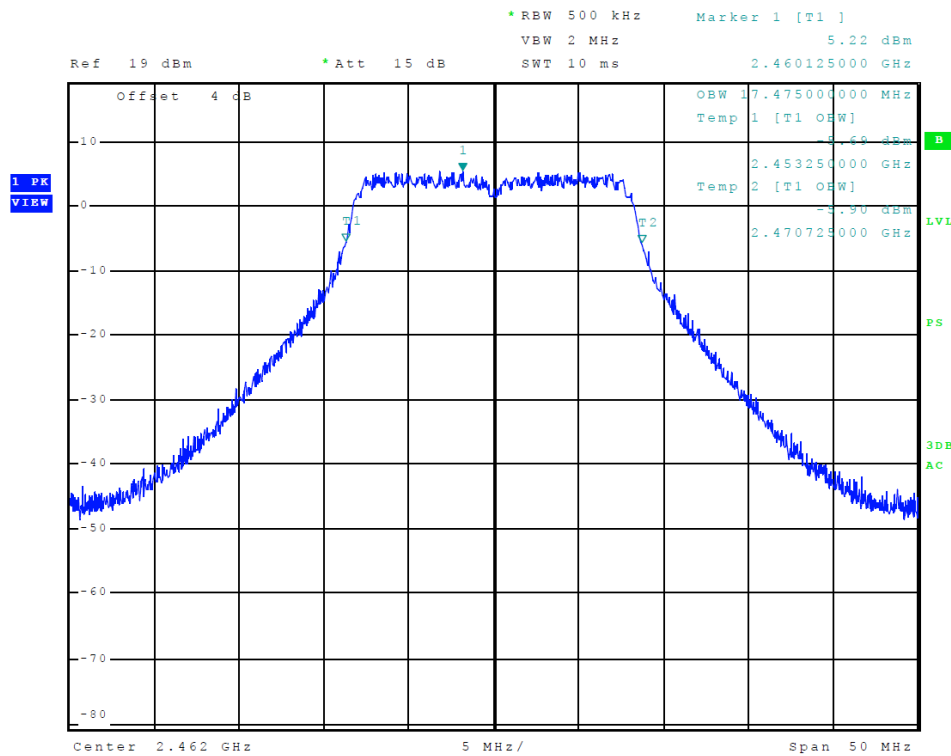

Figure 40 Plot of Transmitter 99% Occupied Band Width (802.11g, Chain 1)

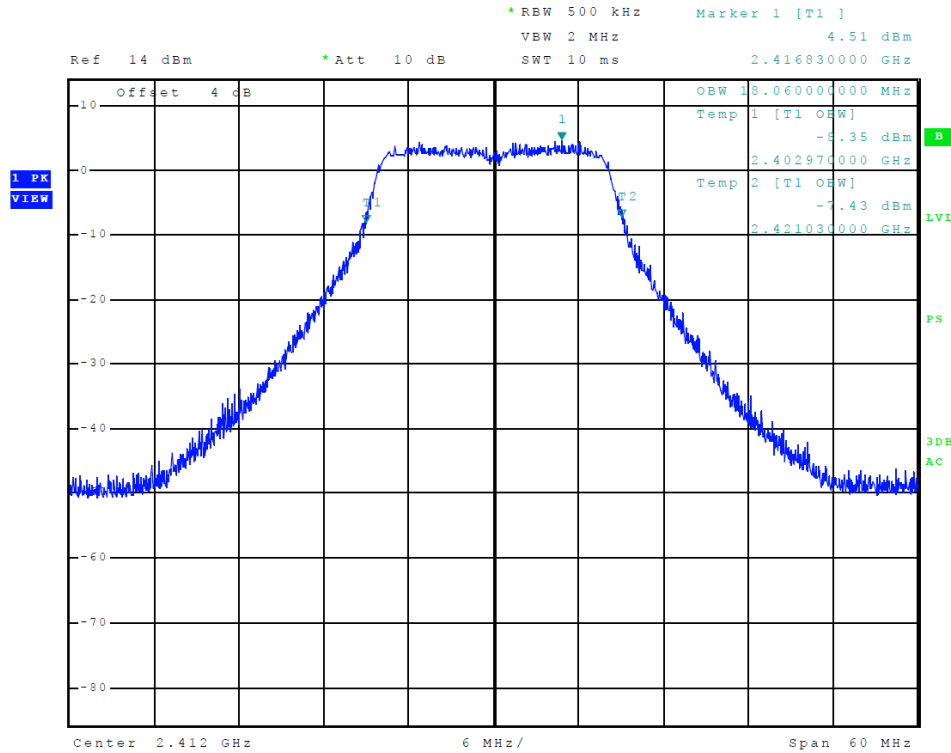

Figure 41 Plot of Transmitter 99% Occupied Band Width (802.11n (20), Chain 0)

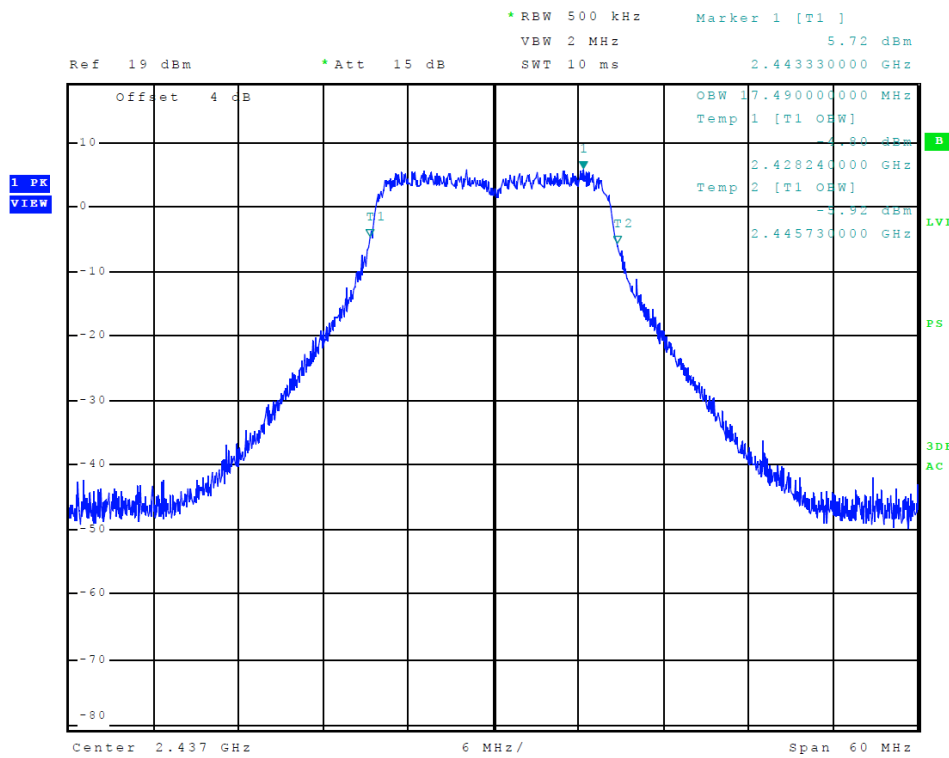

Figure 42 Plot of Transmitter 99% Occupied Band Width (802.11n (20), Chain 1)

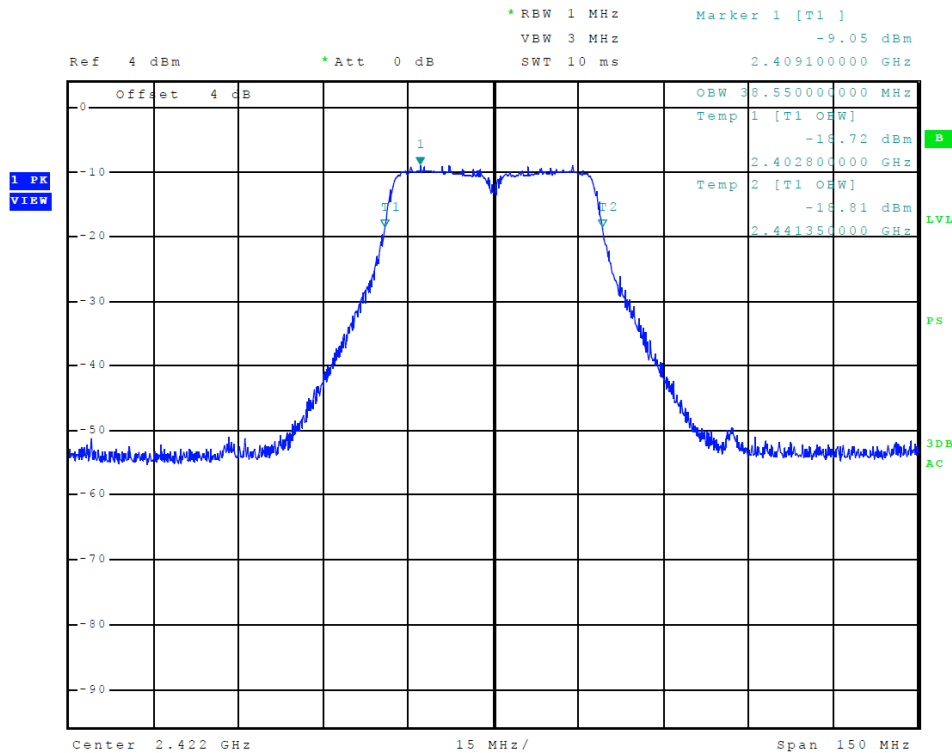

Figure 43 Plot of Transmitter 99% Occupied Band Width (802.11n (40), Chain 0)

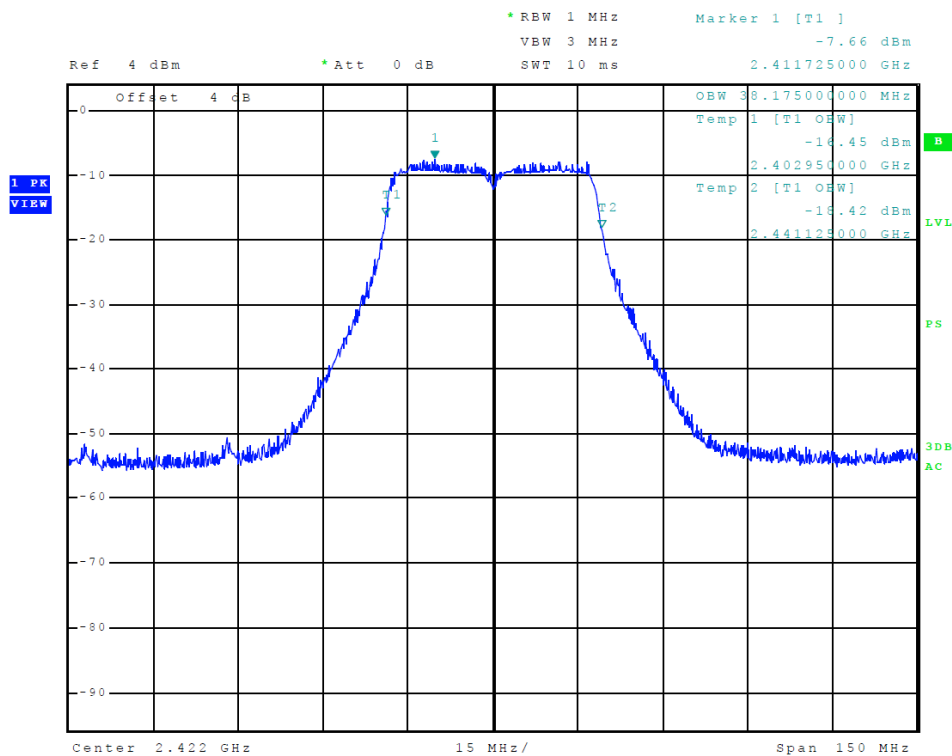

Figure 44 Plot of Transmitter 99% Occupied Band Width (802.11n (40), Chain 1)

Transmitter Emissions Data

Table 8 Transmitter Power and Emissions (Chain 0)

Frequency MHz	Conducted Average Output Power (Watts)	99% Occupied Bandwidth kHz	6-dB Occupied Bandwidth kHz	Power Spectral Density dBm
802.11 b				
2412.0	0.009	13860.0	10075.0	-15.3
2437.0	0.010	13860.0	10075.0	-15.6
2462.0	0.010	13860.0	10100.0	-15.3
802.11 g				
2412.0	0.010	18,040.0	16,350.0	-16.2
2437.0	0.011	18,000.0	16,350.0	-15.4
2462.0	0.011	18,000.0	16,350.0	-17.0
802.11 n (20)				
2412.0	0.010	18,060.0	16,350.0	-15.7
2437.0	0.011	18,030.0	16,260.0	-15.9
2462.0	0.011	18,060.0	16,350.0	-15.7
802.11 n (40)				
2422.0	0.001	38,550.0	36,225.0	-32.4
2447.0	0.001	38,475.0	36,300.0	-31.5
2452.0	0.001	38,475.0	36,450.0	-32.2

Table 9 Transmitter Power and Emissions (Chain 1)

Frequency MHz	Conducted Average Output Power (Watts)	99% Occupied Bandwidth kHz	6-dB Occupied Bandwidth kHz	Power Spectral Density dBm
802.11 b				
2412.0	0.010	13,925.0	10,100.0	-13.8
2437.0	0.011	13,925.0	10,100.0	-13.7
2462.0	0.010	13,925.0	10,100.0	-14.1
802.11 g				
2412.0	0.012	17,475.0	16,400.0	-15.5
2437.0	0.011	17,450.0	16,350.0	-16.2
2462.0	0.011	17,475.0	16,375.0	-15.3
802.11 n (20)				
2412.0	0.012	17,400.0	16,325.0	-15.0
2437.0	0.011	17,490.0	16,375.0	-15.5
2462.0	0.011	17,460.0	16,375.0	-13.4
802.11 n (40)				
2422.0	0.001	38,175.0	36,375.0	-30.8
2447.0	0.001	38,100.0	36,450.0	-31.4
2452.0	0.001	37,950.0	36,300.0	-31.5

Table 10 Transmitter Power and PSD Combined Chains

Frequency MHz	Combined Conducted Peak Antenna Port Output Power (Watts)	Combined Conducted Average Antenna Port Output Power (Watts)	Combined Power Spectral Density dBm
802.11b			
2412.0	0.095	0.019	-11.4
2437.0	0.095	0.020	-11.5
2462.0	0.095	0.020	-11.7
802.11g			
2412.0	0.250	0.022	-12.8
2437.0	0.250	0.022	-12.8
2462.0	0.250	0.022	-13.0
802.11n			
2412.0	0.250	0.022	-12.3
2437.0	0.250	0.021	-12.7
2462.0	0.250	0.021	-11.4
802.11n40			
2422.0	0.015	0.001	-28.5
2447.0	0.015	0.001	-28.4
2452.0	0.015	0.001	-28.8

Table 11 Transmitter Radiated Emissions (802.11b/g/n worst-case)

Frequency in MHz	Horizontal Peak (dB μ V/m)	Horizontal Average (dB μ V/m)	Vertical Peak (dB μ V/m)	Vertical Average (dB μ V/m)	Limit @ 3m (dB μ V/m)
2412.0	-	-	-	-	-
4824.0	47.8	34.3	46.9	34.0	54.0
7236.0	50.3	38.1	51.1	37.8	54.0
9648.0	53.3	40.9	53.7	40.9	54.0
12060.0	56.4	43.7	55.4	43.1	54.0
14472.0	58.1	45.7	57.8	44.8	54.0
16884.0	60.4	47.5	60.5	47.7	54.0
2437.0	-	-	-	-	-
4874.0	47.6	34.5	47.0	34.2	54.0
7311.0	51.5	38.3	50.7	38.3	54.0
9748.0	53.1	40.1	53.0	40.3	54.0
12185.0	57.4	44.7	57.2	44.4	54.0
14622.0	59.1	46.4	59.5	46.0	54.0
17059.0	61.1	48.4	61.6	48.8	54.0
2462.0	-	-	-	-	-
4924.0	47.2	34.2	46.4	34.0	54.0
7386.0	81.4	38.4	50.7	38.4	54.0
9848.0	54.0	41.2	53.9	40.9	54.0
12310.0	57.2	44.8	57.5	45.2	54.0
14772.0	58.5	45.8	58.0	45.5	54.0
17234.0	61.9	48.4	60.9	48.4	54.0

Other emissions present had amplitudes at least 20 dB below the limit. Peak and Quasi-Peak amplitude emissions are recorded above for frequency range of 30-1000 MHz. Peak and Average amplitude emissions are recorded above for frequency range above 1000 MHz.

Table 12 Transmitter Radiated Emissions (802.11n40 worst-case)

Frequency in MHz	Horizontal Peak (dB μ V/m)	Horizontal Average (dB μ V/m)	Vertical Peak (dB μ V/m)	Vertical Average (dB μ V/m)	Limit @ 3m (dB μ V/m)
2422.0	-	-	-	-	-
4844.0	47.1	34.0	46.5	34.0	54.0
7266.0	50.7	37.9	50.5	38.0	54.0
9688.0	53.7	40.9	53.3	40.7	54.0
12110.0	57.9	44.6	57.6	44.4	54.0
14532.0	59.0	46.2	58.7	46.1	54.0
16954.0	60.6	47.9	60.6	47.8	54.0
2447.0	-	-	-	-	-
4894.0	46.6	33.9	46.7	34.0	54.0
7341.0	50.5	38.2	51.0	38.2	54.0
9788.0	52.7	40.7	53.8	40.5	54.0
12235.0	57.3	44.7	57.5	44.8	54.0
14682.0	59.3	45.9	59.1	45.9	54.0
17129.0	61.1	48.1	60.7	48.2	54.0
2452.0	-	-	-	-	-
4904.0	46.4	33.7	46.4	33.6	54.0
7356.0	51.1	38.3	50.8	38.2	54.0
9808.0	52.9	40.4	53.5	40.4	54.0
12260.0	57.8	44.9	57.6	44.9	54.0
14712.0	58.2	45.8	58.5	45.8	54.0
17164.0	61.8	48.6	61.5	48.5	54.0

Other emissions present had amplitudes at least 20 dB below the limit. Peak and Quasi-Peak amplitude emissions are recorded above for frequency range of 30-1000 MHz. Peak and Average amplitude emissions are recorded above for frequency range above 1000 MHz.

Summary of Results for Transmitter Radiated Emissions of Intentional Radiator

The EUT demonstrated compliance with the radiated emissions requirements of 47CFR Part 15.247 and Industry Canada RSS-247. The highest combined conducted peak power was 0.290 Watts and average power of 0.022 Watts. The worst-case peak power spectral density provided a minimum margin of -19.4 dB below the 3 kHz PSD requirements. The minimum radiated harmonic emission provided -5.2 dB margin below requirements. There were no other significantly measurable emissions in the restricted bands other than those recorded in this report. Other emissions were present with amplitudes at least 20 dB below the requirements. There were no other deviations or exceptions to the requirements.

Statement of Modifications and Deviations

No modifications to the EUT were required for the unit to demonstrate compliance with the 47CFR Part 15C paragraph 15.247 and Industry Canada RSS-247 emissions requirements. There were no deviations or modifications to the specifications.

Annex

- Annex A Measurement Uncertainty Calculations
- Annex B Rogers Labs Test Equipment List
- Annex C Rogers Qualifications
- Annex D Rogers Labs Certificate of Accreditation

Annex A Measurement Uncertainty Calculations

Measurement uncertainty calculations were made for the laboratory. Result of measurement uncertainty calculations are recorded below for AC line conducted and radiated emission measurements.

Measurement Uncertainty	U _(E)	U _(lab)
3 Meter Horizontal 30-200 MHz Measurements	2.08	4.16
3 Meter Vertical 30-200 MHz Measurements	2.16	4.33
3 Meter Vertical Measurements 200-1000 MHz	2.99	5.97
10 Meter Horizontal Measurements 30-200 MHz	2.07	4.15
10 Meter Vertical Measurements 30-200 MHz	2.06	4.13
10 Meter Horizontal Measurements 200-1000 MHz	2.32	4.64
10 Meter Vertical Measurements 200-1000 MHz	2.33	4.66
3 Meter Measurements 1-6 GHz	2.57	5.14
3 Meter Measurements 6-18 GHz	2.58	5.16
AC Line Conducted	1.72	3.43

Annex B Rogers Labs Test Equipment List

List of Test Equipment	Calibration	<u>Date (m/d/y)</u>	<u>Due</u>
Antenna: Schwarzbeck Model: BBA 9106/VHBB 9124 (9124-627)		5/2/2018	5/2/2019
Antenna: Schwarzbeck Model: VULP 9118 A (VULP 9118 A-534)		5/2/2018	5/2/2019
Antenna: EMCO 6509		10/24/2016	10/24/2018
Antenna: EMCO 3143 (9607-1277) 20-1200 MHz		5/2/2018	5/2/2019
Antenna: EMCO Dipole Set 3121C		2/23/2018	2/23/2019
Antenna: C.D. B-101		2/23/2018	2/23/2019
Antenna: Solar 9229-1 & 9230-1		2/23/2018	2/23/2019
Cable: Belden 8268 (L3)		10/24/2017	10/24/2018
Cable: Time Microwave: 4M-750HF290-750		10/24/2017	10/24/2018
Frequency Counter: Leader LDC-825 (8060153)		5/2/2018	5/2/2019
Oscilloscope Scope: Tektronix 2230		2/23/2018	2/23/2019
Wattmeter: Bird 43 with Load Bird 8085		2/23/2018	2/23/2019
Power Supplies: Sorensen SRL 20-25, SRL 40-25, DCR 150, DCR 140		2/23/2018	2/23/2019
R.F. Generator: SMB100A6 s/n 100623		5/2/2018	5/2/2019
R.F. Generator: SBMBV100A s/n: 260771		5/2/2018	5/2/2019
R.F. Generators: HP 606A, HP 8614A, HP 8640B		2/23/2018	2/23/2019
R.F. Power Amp 65W Model: 470-A-1010		2/23/2018	2/23/2019
R.F. Power Amp 50W M185- 10-501		2/23/2018	2/23/2019
R.F. Power Amp A.R. Model: 10W 1010M7		2/23/2018	2/23/2019
R.F. Power Amp EIN Model: A301		2/23/2018	2/23/2019
LISN: Compliance Eng. Model 240/20		5/2/2018	15/50/19
LISN: Fischer Custom Communications Model: FCC-LISN-50-16-2-08		5/2/2018	5/2/2019
Audio Oscillator: H.P. 201CD		2/23/2018	2/23/2019
ESD Test Set 2010i		2/23/2018	2/23/2019
Oscilloscope Scope: Tektronix MDO 4104		2/23/2018	2/23/2019
EMC Transient Generator HVT TR 3000		2/23/2018	2/23/2019
AC Power Source (Ametech, California Instruments)		2/23/2018	2/23/2019
Fast Transient Burst Generator Model: EFT/B-101		2/23/2018	2/23/2019
Field Intensity Meter: EFM-018		2/23/2018	2/23/2019
KEYTEK Ecat Surge Generator		2/23/2018	2/23/2019
ESD Simulator: MZ-15		2/23/2018	2/23/2019
Shielded Room not required			

Annex C Rogers Qualifications

Scot D. Rogers, Engineer

Rogers Labs, Inc.

Mr. Rogers has approximately 27 years' experience in the field of electronics. Engineering experience includes six years in the automated controls industry and remaining years working with the design, development and testing of radio communications and electronic equipment.

Positions Held

Systems Engineer: A/C Controls Mfg. Co., Inc. 6 Years

Electrical Engineer: Rogers Consulting Labs, Inc. 5 Years

Electrical Engineer: Rogers Labs, Inc. Current

Educational Background

- 1) Bachelor of Science Degree in Electrical Engineering from Kansas State University.
- 2) Bachelor of Science Degree in Business Administration Kansas State University.
- 3) Several Specialized Training courses and seminars pertaining to Microprocessors and Software programming.

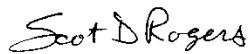

Scot D. Rogers

Annex D Rogers Labs Certificate of Accreditation

United States Department of Commerce
National Institute of Standards and Technology

NVLAP[®]

Certificate of Accreditation to ISO/IEC 17025:2005

NVLAP LAB CODE: 200087-0

Rogers Labs, Inc.
Louisburg, KS

*is accredited by the National Voluntary Laboratory Accreditation Program for specific services,
listed on the Scope of Accreditation, for:*

Electromagnetic Compatibility & Telecommunications

*This laboratory is accredited in accordance with the recognized International Standard ISO/IEC 17025:2005.
This accreditation demonstrates technical competence for a defined scope and the operation of a laboratory quality
management system (refer to joint ISO-ILAC-IAF Communiqué dated January 2009).*

2018-02-21 through 2019-03-31
Effective Dates



For the National Voluntary Laboratory Accreditation Program

Rogers Labs, Inc. Mikrotikls SIA S/N: 84AD08CAE425, 84AD08300865
4405 W. 259th Terrace Model: RB911G-2HPnD-12S FCC ID: TV7RB911G2HPND
Louisburg, KS 66053 Test #: 180509 IC: 7442A-911G2HPND
Phone/Fax: (913) 837-3214 Test to: 47CFR 15.247, RSS-247 Date: June 26, 2018
Revision 2 File: Mikrotikls RB9112HPnD12S DTS TstRpt 180509 r2 Page 64 of 64