

Submittal Application Report

For
Grant of Certification

FOR

Model: R52HnD
2412-2462 MHz

Broadband Digital Transmission System

FCC ID: TV7R52HND

IC: 7442A-R52HND

FOR

Mikrotikls SIA

Pernavas 46 Str.

Riga LV-1009 Latvia

Test Report Number: 160720

IC Test Site Registration: 3041A-1

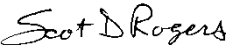
Authorized Signatory: 
Scot D. Rogers

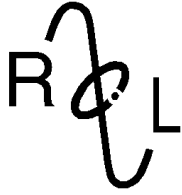

ROGERS LABS, INC.

4405 West 259th Terrace
Louisburg, KS 66053
Phone / Fax (913) 837-3214

Engineering Test Report for
Grant of Certification Application
FOR
Broadband Digital Transmission System
CFR 47, PART 15C - Paragraph 15.247
Industry Canada RSS-247 Issue1
License Exempt Intentional Radiator
For

Mikrotikls SIA

Pernavas 46 Str.
Riga LV-1009 Latvia

Broadband Digital Transmission System

Model: R52HnD
Frequency Range 2412-2462 MHz
FCC: TV7R52HND
IC: 7442A-R52HND

Test Date: July 20, 2016

Certifying Engineer: *Scot D. Rogers*
Scot D. Rogers
Rogers Labs, Inc.
4405 West 259th Terrace
Louisburg, KS 66053
Telephone/Facsimile: (913) 837-3214

This report shall not be reproduced except in full, without the written approval of the laboratory.
This report must not be used by the client to claim product certification, approval, or endorsement by
NVLAP, NIST, or any agency of the Federal Government.

Rogers Labs, Inc.
4405 W. 259th Terrace
Louisburg, KS 66053
Phone/Fax: (913) 837-3214
Revision 1

Mikrotikls SIA
Model: R52HnD
Test #: 160720
Test to: 47CFR 15.247, RSS-247
File: Mikrotikls R52HnD DTS TstRpt 160720

S/N: 26114
FCC: TV7R52HND
IC: 7442A-R52HND
Date: August 24, 2016
Page 2 of 68



NVLAP Lab Code 200087-0

Table Of Contents

TABLE OF CONTENTS..... 3

REVISIONS..... 7

FORWARD 8

OPINION / INTERPRETATION OF RESULTS 8

EQUIPMENT TESTED..... 8

 Antennas used during testing and requested for authorization9

EQUIPMENT FUNCTION AND CONFIGURATION..... 9

 Equipment Configuration.....10

APPLICANT COMPANY INFORMATION 11

 Equipment information11

 Product Details12

 Accessories13

 Table for Filed Antennas13

 Table for Carrier Frequencies13

 Table for Test Modes14

 Test Result of Occupied Bandwidth16

APPLICATION FOR CERTIFICATION..... 17

APPLICABLE STANDARDS & TEST PROCEDURES 18

EQUIPMENT TESTING PROCEDURES 18

 AC Line Conducted Emission Test Procedure18

 Radiated Emission Test Procedure.....18

 Diagram 1 Test arrangement for Conducted emissions19

 Diagram 2 Test arrangement for radiated emissions of tabletop equipment.....20

Diagram 3 Test arrangement for radiated emissions tested on Open Area Test Site (OATS)21

TEST SITE LOCATIONS 21

LIST OF TEST EQUIPMENT 22

UNITS OF MEASUREMENTS 23

ENVIRONMENTAL CONDITIONS..... 23

INTENTIONAL RADIATORS..... 23

Antenna Requirements23

Restricted Bands of Operation.....23

Table 1 General Radiated Emissions in Restricted Bands Data (worst-case, 20 MHz, WLO-2450-15)24

Table 2 General Radiated Emissions in Restricted Bands Data (worst-case, 40 MHz, WLO-2450-15)24

Table 3 General Radiated Emissions in Restricted Bands Data (worst-case, 20 MHz, ODH-24-13).....25

Table 4 General Radiated Emissions in Restricted Bands Data (worst-case, 40 MHz, ODH-24-13).....25

Table 5 General Radiated Emissions in Restricted Bands Data (worst-case, 20 MHz, WLP-2450-20).....26

Table 6 General Radiated Emissions in Restricted Bands Data (worst-case, 40 MHz, WLP-2450-20).....26

Table 7 General Radiated Emissions in Restricted Bands Data (worst-case, 20 MHz, SA24-90-17-WB)27

Table 8 General Radiated Emissions in Restricted Bands Data (worst-case, 40 MHz, SA24-90-17-WB)27

Table 9 General Radiated Emissions in Restricted Bands Data (worst-case, 20 MHz, DC 24-HD-PFIP).....28

Table 10 General Radiated Emissions in Restricted Bands Data (worst-case, 40 MHz, DC 24-HD-PFIP).....28

Summary of Results for Radiated Emissions in Restricted Bands29

AC Line Conducted Emissions Procedure29

Figure 1 AC Line Conducted Emissions Line 130

Figure 2 AC Line Conducted Emissions Line 230

Table 11 AC Line Conducted Emissions Data (Highest Emissions Line L1)31

Table 12 AC Line Conducted Emissions Data (Highest Emissions Line L2)31



NVLAP Lab Code 200087-0

Summary of Results for AC Line Conducted Emissions31

General Radiated Emissions Procedure.....32

Table 13 General Radiated Emissions from EUT Data (Highest Emissions) 33

Summary of Results for General Radiated Emissions 33

Operation in the 2400-2483.5 MHz Frequency Band.....34

Figure 3 Plot of Transmitter Emissions (Across Operational Band 802.11b, Chain 0)35

Figure 4 Plot of Transmitter Emissions (Across Operational Band, 802.11g, Chain 0) 35

Figure 5 Plot of Transmitter Emissions (Across Operational Band, 802.11n (HT20), Chain 0) 36

Figure 6 Plot of Transmitter Emissions (Across Operational Band, 802.11n (40), Chain 0) 36

Figure 7 Plot of Transmitter Low Band Edge (802.11b, Chain 0).....37

Figure 8 Plot of Transmitter Low Band Edge (802.11g, Chain 0)..... 37

Figure 9 Plot of Transmitter Low Band Edge (802.11n (HT20), Chain 0)..... 38

Figure 10 Plot of Transmitter Low Band Edge (802.11n (40), Chain 0) 38

Figure 11 Plot of Transmitter High Band Edge (802.11b, Chain 0)39

Figure 12 Plot of Transmitter High Band Edge (802.11g, Chain 0) 39

Figure 13 Plot of Transmitter High Band Edge (802.11n (HT20), Chain 0) 40

Figure 14 Plot of Transmitter High Band Edge (802.11n (40), Chain 0) 40

Figure 15 Plot of Transmitter 6-dB Occupied Band Width (802.11b, Chain 0)41

Figure 16 Plot of Transmitter 6-dB Occupied Band Width (802.11g, Chain 0) 41

Figure 17 Plot of Transmitter 6-dB Occupied Band Width (802.11n, (HT20) Chain 0) 42

Figure 18 Plot of Transmitter 6-dB Occupied Band Width (802.11n (40), Chain 0) 42

Figure 19 Plot of Transmitter Emissions (Across Operational Band 802.11b, Chain 1)43

Figure 20 Plot of Transmitter Emissions (Across Operational Band, 802.11g, Chain 1) 43

Figure 21 Plot of Transmitter Emissions (Across Operational Band, 802.11n (20), Chain 1) 44

Figure 22 Plot of Transmitter Emissions (Across Operational Band, 802.11n (40), Chain 1) 44

Rogers Labs, Inc.
 4405 W. 259th Terrace
 Louisburg, KS 66053
 Phone/Fax: (913) 837-3214
 Revision 1

Mikrotikls SIA
 Model: R52HnD
 Test #: 160720
 Test to: 47CFR 15.247, RSS-247
 File: Mikrotikls R52HnD DTS TstRpt 160720

S/N: 26114
 FCC: TV7R52HND
 IC: 7442A-R52HND
 Date: August 24, 2016
 Page 5 of 68

Figure 23 Plot of Transmitter Low Band Edge (802.11b, Chain 1).....45

Figure 24 Plot of Transmitter Low Band Edge (802.11g, Chain 1).....45

Figure 25 Plot of Transmitter Low Band Edge (802.11n (20), Chain 1)46

Figure 26 Plot of Transmitter Low Band Edge (802.11n (40), Chain 1)46

Figure 27 Plot of Transmitter High Band Edge (802.11b, Chain 1)47

Figure 28 Plot of Transmitter High Band Edge (802.11g, Chain 1)47

Figure 29 Plot of Transmitter High Band Edge (802.11n (20), Chain 1)48

Figure 30 Plot of Transmitter High Band Edge (802.11n (40), Chain 1)48

Figure 31 Plot of Transmitter 6-dB Occupied Band Width (802.11b, Chain 1)49

Figure 32 Plot of Transmitter 6-dB Occupied Band Width (802.11g, Chain 1).....49

Figure 33 Plot of Transmitter 6-dB Occupied Band Width (802.11n (20), Chain 1)50

Figure 34 Plot of Transmitter 6-dB Occupied Band Width (802.11n (40), Chain 1)50

Transmitter Emissions Data.....51

Table 14 Transmitter Power and Emissions51

Table 15 Transmitter Radiated Emissions (Worst-case 20 MHz mode, WLO-2450-15).....52

Table 16 Transmitter Radiated Emissions (Worst-case 40 MHz mode, WLO-2450-15).....53

Table 17 Transmitter Radiated Emissions (Worst-case 20 MHz mode, ODH 24-13).....54

Table 18 Transmitter Radiated Emissions (Worst-case 40 MHz mode, ODH 24-13).....55

Table 19 Transmitter Radiated Emissions (Worst-case 20 MHz mode, WLP-2450-20).....56

Table 20 Transmitter Radiated Emissions (Worst-case 40 MHz mode, WLP-2450-20).....57

Table 21 Transmitter Radiated Emissions (Worst-case 20 MHz mode, SA 24-90-17-WB)58

Table 22 Transmitter Radiated Emissions (Worst-case 40 MHz mode, SA 24-90-17-WB)59

Table 23 Transmitter Radiated Emissions (Worst-case 20 MHz mode, DC 24-HD-PFIP).....60

Table 24 Transmitter Radiated Emissions (Worst-case 40 MHz mode, DC 24-HD-PFIP).....61

Summary of Results for Transmitter Radiated Emissions of Intentional Radiator.....62

STATEMENT OF MODIFICATIONS AND DEVIATIONS 62

ANNEX..... 63

Annex A Measurement Uncertainty Calculations.....64

Annex B Rogers Labs Test Equipment List.....65

Annex C Rogers Qualifications66

Annex D FCC Site Registration Letter.....67

Annex E Industry Canada Site Registration Letter68

Revisions

Revision 1 Issued August 24, 2016

Forward

The following information is submitted for consideration in obtaining Grant of Certification for License Exempt Digital Transmission System Intentional Radiator operating under 47CFR Paragraph 15.247 and RSS-247 Issue 1 Digital Modulation transmitter operation in the 2412-2462 MHz band.

Name of Applicant: Mikrotiks SIA FRN: 0014 43 1100
 Pernavas 46 Str.
 Riga LV-1009 Latvia

Model: R52HnD

FCC ID: TV7R52HND IC: 7442A-R52HND

Frequency Range: 2412-2462 MHz (802.11b/g/n mode operation), 2422-2452 MHz (802.11n 40 MHz channel operation)

Total Operating Power: average power 0.378 watts all chains, OBW 19,410 or 39,525 kHz

Opinion / Interpretation of Results

Tests Performed	Margin (dB)	Results
Restricted Frequency Bands 15.205, RSS-GEN 8.10	-0.6	Complies
AC Line Conducted 15.207, RSS-GEN 7.2.4	-10.1	Complies
Radiated Emissions 15.209, RSS-GEN 7.2.5	-1.2	Complies
Harmonic Emissions per 15.247, RSS-247	-9.0	Complies
Peak Power Spectral Density per 15.247, RSS-247	-6.8	Complies

Equipment Tested

<u>Equipment</u>	<u>Model</u>	<u>FCC I.D.</u>
EUT	R52HnD	TV7R52HND
AC Adapter	FLD301-240120-U	N/A
Power Adapter	POE	N/A
Dell Studio XPS	921LBN1	N/A

Test results in this report relate only to the items tested.

Antennas used during testing and requested for authorization

2.4 GHz antennas

- Omni Directional (2.4 GHz) WLO-2450-15 15 dBi
- Omni Directional (2.4 GHz) WLO-2450-15 15 dBi
- Omni Directional HP (2.4 GHz) ODH 24-13 13 dBi
- Panel (2.4 GHz) WLP-2450-20 20 dBi
- Sector (2.4 GHz) SA 24-90-17-WB 17 dBi
- Dish (2.4 GHz) DC 24-HD-PFIP 24 dBi

5 GHz antennas

- Omni Directional (8.5 dBi) MT-482016/N/A
- Panel Antenna (24 dBi) PA58-24-ANT
- Dish Antenna (32 dBi) HDDA5W-32-DP2

Equipment Function and Configuration

The EUT is a 2412-2462 MHz and 5 GHz Dual Chain Digital Transmission System Module. The module is a Wireless Mini PCI Card providing an OEM the ability to install the device into systems data transmissions in applications offering broadband wireless connectivity. The module requires placement into a Mini PCI card slot for operation. The Mini PCI card slot provides the module with power and communications interface with the host digital product. The module provides two MMCX antenna connectors for use with compliant antenna systems as documented in this filing for authorized use. The system provides two transmitter chains which may operate in either a 2x2 MiMo (2.4 GHz mode), 1x1 (2.4 GHz) and 1x1 (5GHz mode), or 2x2 (5GHz) configuration. The module was tested without an enclosure while placed on the open printed circuit board (host system for testing was a RB 433 interface board). The support system was powered from an AC adapter during testing and provided network communications interface to control the EUT. Five 2.4 GHz antenna systems and three 5 GHz antenna systems were provided for testing on the Open Area Test Site for radiated emissions compliance. For testing purposes, the EUT transceiver was connected to the manufacturer supplied interface support board, which was communicating with a laptop computer for transmitter control and communications. This configuration provided operational control of the EUT and communications over the network interface between the EUT and supporting computer system. The design provides no other interfacing options than those described in this filing. For testing purposes, the R52HnD was configured to transmit in available data modes receiving power from the manufacturer provided support interface board and AC/DC power adapter.

Equipment Configuration

Authorized external antennas

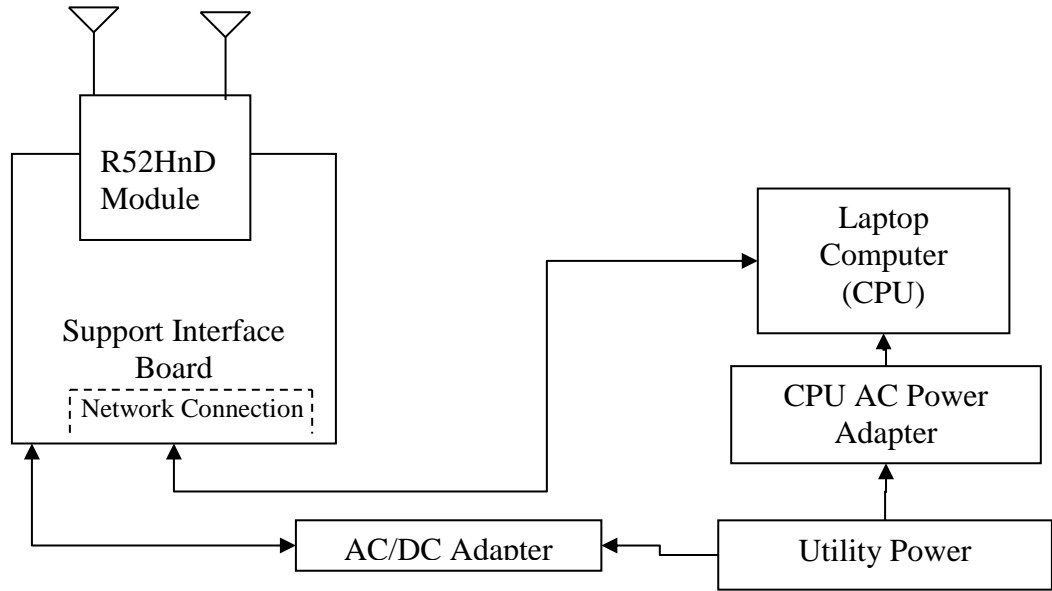

Applicant Company information

Applicants Company	MikroTik (“Mikrotīkls, SIA”)
Applicants Address	Pernavas 46 Str., Riga LV-1009 Latvia
FCC Identifier	TV7R52HND
Industry Canada Identifier	7442A-R52HND
Manufacturer Company	MikroTik (“Mikrotīkls, SIA”)
Manufacturer Address	Pernavas 46 Str., Riga LV-1009 Latvia

Equipment information

<p>Product Marketing Name (PMN) :</p> <p>The PMN is the name or model number under which the product will be marketed/offered for sale in Canada. If the product has PMN, it must be provided.</p>	R52HnD
<p>Unique Product Number (UPN):</p> <p>The applicant, made up of a maximum of 11 alphanumeric characters (A-Z, 0-9), assigns the UPN.</p>	R52HND
<p>Hardware Version Identification Number (HVIN):</p> <p>The HVIN identifies hardware specifications of a product version. The HVIN replaces the ISED Model Number in the legacy E-filing System. An HVIN is required for all products for certification applications.</p>	R52HnD
<p>Host Marketing Name (HMN) (if applicable):</p> <p>The HMN is the name or model number of a final product, which contains a certified radio module.</p>	RB-433 (for testing this module)
Brand Name	
Model Number	R52HnD
Test Rule Part(s)	47CFR Parts 15C & 15E, 15.247, 15.407, RSS-247
Test Frequency Range	2,400 – 2,483.5 MHz, 5.15-5.25 and 5.725-5.85GHz
Project Number	160720
Submission Type	Certification

Product Details

Items	Description
Product Type	WLAN [2x2 MIMO, (2TX, 2RX)] 2 GHz or WLAN [2x2MIMO, (2TX, 2RX)] 5 GHz
Radio Type	Intentional Transceiver
Power Type	Direct current provided from host station interface
Modulation	IEEE 802.11a: OFDM IEE 802.11a/n: see the below table
Data Modulation	IEEE 802.11 a/n: OFDM (BPSK/QPSK/16QAM/64QAM) IEEE 802.11ac: OFDM (BPSK/QPSK/16QAM/64QAM/256QAM) IEEE 802.11 g/n: OFDM (BPSK/QPSK/16QAM/64QAM) IEEE 802.11 b: DSSS
Data Rate (Mbps)	IEEE 802.11a/g: OFDM (6/9/12/18/24/36/48/54) IEEE 802.11n/ac: see the below table IEEE 802.11b: (1/2/2s/5/5s/11/11s)
Frequency Range	2400-2483.5 MHz / 5150-5250 MHz / 5725-5850 MHz
Channel Number	802.11b: 11 for 20MHz bandwidth 802.11g/n: 11 for 20MHz bandwidth; 5 for 40MHz bandwidth 802.11a/n: 9 for 20MHz bandwidth; 4 for 40MHz bandwidth 802.11 a/c: 2 for 80 MHz bandwidth
Channel Band Width (99%)	802.11 b: 15960 kHz 802.11 g: 19410 kHz 802.11 n (HT-40): 39525 kHz U-NII-1: IEEE 802.11a: 19800 kHz IEEE 802.11a/n MCSO/Nss1 (VHT20): 18560 kHz IEEE 802.11a/n MCSO/Nss1 (VHT40): 38550 kHz IEEE 802.11a/c (VHT80): _____ kHz U-NII-4: IEEE 802.11a: 19760 kHz IEEE 802.11a/n MCSO/Nss1 (VHT20): 19720 kHz IEEE 802.11 a/n MCSO/Nss1 (VHT40): 38550 kHz IEEE 802.11 a/c MCSO/Nss1 (VHT80): _____ kHz
Maximum Conducted Output Power	IEEE 802.11b: 0.209 W per chain, 0.377 W total IEEE 802.11g: 0.174 W per chain, 0.349 W total IEEE 802.11n (40): 0.156 W per chain, 0.303 W total
Carrier Frequencies	Please refer to Table for Carrier Frequencies
Antenna	Internal MMCX ports for use with authorized antennas
Communication Mode	Device is operating in a 2x2 Spatial Multiplexing MIMO configuration. The design utilizes Multiple-Input-Multiple-Output (MIMO) operational capability. The design may be configured to transmit on all same time or chosen single chain (without automatic switching between chains). The unit

	may receive on single or all chains and may transmit on single or all chains. Configuration could be (1tx, 1rx); (1tx, 2rx); (2tx, 1rx); (2tx, 2rx) Design provides transmitting on both chains at same time.
Beamforming Function	Without beamforming
Operating Mode	2.4 GHz, 5150-5250 MHz (U-NII-1 band) and 5725-5825 MHz (U-NII-3) and restricted to indoor operation for use in Canada

Accessories

AC Power Adapter	FLD301-240120-U
Power Over Ethernet (POE) adapter	POE

Table for Filed Antennas

Ant.	Brand	Model Name	P/N	Antenna Type	Connector	Gain (dBi)	
						2.4GHZ	5GHZ
1	Mikrotikls	WLO-2450-15		Omni	Female -N	15 dBi	
2	Mikrotikls	ODH 24-13		Hor-Omni	Female -N	13 dBi	
3	Mikrotikls	WLP-2450-20		Panel	Female -N	20 dBi	
4	Mikrotikls	SA 24-90-17-WB		Sector	Female -N	17 dBi	
5	Mikrotikls	DC 24-HD-PFIP		Grid Dish	Female -N	24 dBi	
6	Mikrotikls	MT-482016/N/A		Omni	Female -N		8.5 dBi
7	Mikrotikls	PA58-24-ANT		Panel	Female -N		24 dBi
8	Mikrotikls	HDDA5W-32-DP2		Dish	Female -N		32 dBi

Table for Carrier Frequencies

For 20MHz bandwidth systems, use Channel 1,6,11, 36, 40, 44, 48, 149, 153, 157, 161, 165.

For 40MHz bandwidth systems, use Channel 38, 46, 151, 159.

Frequency Band	Channel No.	Frequency	Channel No.	Frequency
2400-2483.5MHz	1	2412	2	2422
	6	2437	7	2447
	11	2462	10	2452
5150-5250MHz U-NII-1	36	5180MHz	44	5220MHz
	38	5190MHz	46	5230MHz
	40	5200MHz	48	5240MHz
	42	5210MHz	-	-
5725-5850MHz U-NII-3	149	5745MHz	157	5785MHz
	151	5755MHz	159	5795MHz
	153	5765MHz	161	5805MHz
	155	5775MHz	165	5825MHz

Table for Test Modes

Preliminary tests were performed in different data rates to define the worst radiated emission. The data rate shown in the table below is the worst-case rate with respect to the specific test item. Investigation has been done on all possible configurations while searching the worst cases. The following table is a list of the test modes investigated for this report.

Test Items	Mode	Data Rate	Channel	Chain	
Max. Conducted Output Power	802.11b	11	1,6,11	1,2,3	
	802.11g	54	1,6,11	1,2,3	
	802.11n HT20	65	1,6,11	1,2,3,3	
	802.11n HT40	135	2,7,10	1,2,3	
	11 a BPSK	Band 1&4	6Mbps	36/40/48/149/157/165	1,2,3
	11a/n VHT20	Band 1&4	MCSO/Nss1	36/40/48/149/157/165	1,2,3
	11a/n VHT40	Band 1&4	MCSO/Nss1	38/46/151/159	1,2,3
	11a/n VHT80	Band 1&4	MCSO/Nss1	42,155	1,2,3
Power Spectral Density	802.11b		1,6,11	1,2,3	
	802.11g		1,6,11	1,2,3	
	802.11n HT20		1,6,11	1,2,3	
	802.11n HT40		2,7,10	1,2,3	
	11a BPSK	Band 1&4	6Mbps	36//40/48/149/157/165	1,2,3
	11a/n VHT20	Band 1&4	MCSO/Nss1	36/40/48/149/157/165	1,2,3
	11a/n VHT40	Band 1&4	MCSO/Nss1	38/46/151/159	1,2,3
	11a/n VHT80	Band 1&4	MCSO/Nss1	42,155	1,2,3
26dB, 99% Occupied Bandwidth Measurement	802.11b		1,6,11	1,2,3	
	802.11g		1,6,11	1,2,3	
	802.11n HT20		1,6,11	1,2,3	
	802.11n HT40		2,7,10	1,2,3	
	11a BPSK	Band 1&4	6Mbps	36/40/48/149/157/165	1,2,3
	11a/n VHT20	Band 1&4	MCSO/Nss1	36/40/48/149/157/165	1,2,3
	11a/n VHT40	Band 1&4	MCSO/Nss1	38/46/151/159	1,2,3
	11a/n VHT80	Band 1&4	MCSO/Nss1	42,155	1,2,3
	802.11b		1,6,11	1,2,3	
	802.11g		1,6,11	1,2,3	

6dB Spectrum Bandwidth Measurement	802.11n HT20			1,6,11	1,2,3
	802.11n HT40			2,7,10	1,2,3
	11a BPSK	Band 4	6Mbps	149/157/165	1,2,3
	11a/n VHT20	Band 4	MCSO/Nss1	149/157/165	1,2,3
	11a/n VHT40	Band 4	MCSO/Nss1	151/159	1,2,3
	11a/n VHT80	Band 4	MCSO/Nss1	42,155	1,2,3
Radiated Emission Below 1GHz			-	-	
Radiated Emission Above 1GHz	802.11b			1,6,11	1,2,3
	802.11g			1,6,11	1,2,3
	802.11n HT20			1,6,11	1,2,3
	802.11n HT40			2,7,10	1,2,3
	11a BPSK	Band 1&4	6Mbps	36/40/48/149/157/165	1,2,3
	11a/n VHT20	Band 1&4	MCSO/Nss1	36/40/48/149/157/165	1,2,3
	11a/n VHT40	Band 1&4	MCSO/Nss1	38/46/151/159	1,2,3
	11a/n VHT80	Band 1&4	MCSO/Nss1	42,155	1,2,3
Band Edge Emission	802.11b			1,6,11	1,2,3
	802.11g			1,6,11	1,2,3
	802.11n HT20			1,6,11	1,2,3
	802.11n HT40			2,7,10	1,2,3
	11a BPSK	Band 1&4	6Mbps	36/40/48/149/157/165	1,2,3
	11a/n VHT20	Band 1&4	MCSO/Nss1	36/40/48/149/157/165	1,2,3
	11a/n VHT40	Band 1&4	MCSO/Nss1	38/46/151/159	1,2,3
	11a/n VHT80	Band 1&4	MCSO/Nss1	42,155	1,2,3
Frequency Stability	20MHz	Band 1&4	-	40/157	
	40MHz	Band 1&4	-	38/151	
	80MHz	Band 1&4	-		

Test Result of Occupied Bandwidth

Mode	Frequency	26dB Bandwidth (kHz)	6dB Bandwidth (kHz)	99% Occupied Bandwidth (kHz)
802.11b	2412 MHz	N/A	12240 kHz	15870 kHz
	2437 MHz	N/A	12240 kHz	15960 kHz
	2462 MHz	N/A	12240 kHz	15960 kHz
802.11g	2412 MHz	N/A	16640 kHz	18880 kHz
	2437 MHz	N/A	16770 kHz	18960 kHz
	2462 MHz	N/A	16920 kHz	19410 kHz
802.11n (HT20)	2412 MHz	N/A	16840 kHz	18880 kHz
	2437 MHz	N/A	16770 kHz	18800 kHz
	2462 MHz	N/A	16650 kHz	18870 kHz
802.11n (HT40)	2422 MHz	N/A	37275 kHz	39000 kHz
	2447 MHz	N/A	36975 kHz	39225 kHz
	2452 MHz	N/A	36750 kHz	39525 kHz
802.11a	5180 MHz	23750 kHz	N/A	19800 kHz
	5200 MHz	23320 kHz	N/A	19600 kHz
	5240 MHz	23800 kHz	N/A	19600 kHz
	5745 MHz	N/A	16400 kHz	19760 kHz
	5785 MHz	N/A	16400 kHz	19640 kHz
	5825 MHz	N/A	16400 kHz	19720 kHz
802.11n (ht20)	5180 MHz	25120 kHz	N/A	18560 kHz
	5200 MHz	25120 kHz	N/A	18400 kHz
	5240 MHz	24240 kHz	N/A	18320 kHz
	5745 MHz	N/A	16400 kHz	19720 kHz
	5785 MHz	N/A	16400 kHz	19560 kHz
	5825 MHz	N/A	16400 kHz	19560 kHz
802.11a/n MCSO/Nss1 VHT40	5190 MHz	49650 kHz	N/A	38550 kHz
	5230 MHz	49125 kHz	N/A	38250 kHz
	5755 MHz	N/A	36300 kHz	38550 kHz
	5795 MHz	N/A	36375 kHz	38175 kHz
802.11ac VHT80	5210 MHz	_____ kHz	N/A	_____ kHz
802.11ac VHT80	5775 MHz	N/A	_____ kHz	_____ kHz

Application for Certification

- (1) Manufacturer: Mikrotiks SIA
 Pernavas 46 Str.
 Riga LV-1009 Latvia
- (2) Identification: Model: R52HnD
 FCC I.D.: TV7R52HND IC: 7442A-R52HND
- (3) Instruction Book:
 Refer to Exhibit for Instruction Manual.
- (4) Description of Circuit Functions:
 Refer to Exhibit of Operational Description.
- (5) Block Diagram with Frequencies:
 Refer to Exhibit of Operational Description.
- (6) Report of Measurements:
 Report of measurements follows in this Report.
- (7) Photographs: Construction, Component Placement, etc.:
 Refer to Exhibit for photographs of equipment.
- (8) List of Peripheral Equipment Necessary for operation. The equipment requires power and communications interfaces provided from host installation equipment. Thee module provides MMCX antenna connection ports for use with authorized antenna systems.
- (9) Transition Provisions of 47CFR 15.37 are not requested
- (10) Not Applicable. The unit is not a scanning receiver.
- (11) Not Applicable. The EUT does not operate in the 59 – 64 GHz frequency band.
- (12) The equipment is not software defined and this section is not applicable.
- (13) Applications for certification of U-NII devices in the 5.15-5.35 GHz and the 5.47-5.85 GHz bands must include a high-level operational description of the security procedures that control the radio frequency operating parameters and ensure that unauthorized modifications cannot be made. Not applicable to this filing.
- (14) Contain at least one drawing or photograph showing the test set-up for each of the required types of tests applicable to the device for which certification is requested. These drawings or photographs must show enough detail to confirm other information contained in the test report. Any photographs used must be focused originals without glare or dark spots and must clearly show the test configuration used. This information is provide in this report and Test Setup Exhibits provided with the application filing.

Applicable Standards & Test Procedures

The following information is submitted in accordance with e-CFR dated July 20, 2016, Part 2, Subpart J, Paragraphs 2.907, 2.911, 2.913, 2.925, 2.926, 2.1031 through 2.1057, and applicable parts of paragraph 15, Part 15C including Paragraphs 15.212, 15.247 and Industry Canada RSS-247. Test procedures used are the established Methods of Measurement of Radio-Noise Emissions as described in ANSI C63.10-2013, KDB 558074 D01 v03r05, KDB 662911 D01 v01, RSS-247 Issue 1, and RSS-GEN Issue 4, the following information is submitted for processing application for Certification.

Equipment Testing Procedures

AC Line Conducted Emission Test Procedure

Testing for the AC line-conducted emissions was performed as defined in ANSI C63.10-2013. The test setup, including the EUT, was arranged in the test configurations as presented during testing. The test configuration was placed on a 1 x 1.5-meter wooden bench, 0.8 meters high located in a screen room. The power lines of the system were isolated from the power source using a standard LISN with a 50- μ Hy choke. EMI was coupled to the spectrum analyzer through a 0.1 μ F capacitor internal to the LISN. The LISN was positioned on the floor beneath the wooden bench supporting the EUT. The power lines and cables were draped over the back edge of the table. Refer to diagram one showing typical test arrangement and photographs in exhibits for EUT placement used during testing.

Radiated Emission Test Procedure

Radiated emission testing was performed as required and specified in ANSI C63.10-2013 and referenced KDB documents. The EUT was placed on a rotating 0.9 x 1.2-meter platform, elevated as required above the ground plane at a distance of 3 meters from the FSM antenna. The table permitted orientation of the EUT in each of three orthogonal axis positions during testing. EMI energy was maximized by equipment placement, raising and lowering the FSM antenna, changing the antenna polarization, and by rotating the turntable. Each emission was maximized before data was taken using a spectrum analyzer. The frequency spectrum from 9 kHz to 25,000 MHz was searched for during preliminary investigation. Refer to diagrams two and three showing typical test arrangement and photographs in the test setup exhibits for specific EUT placement during testing.

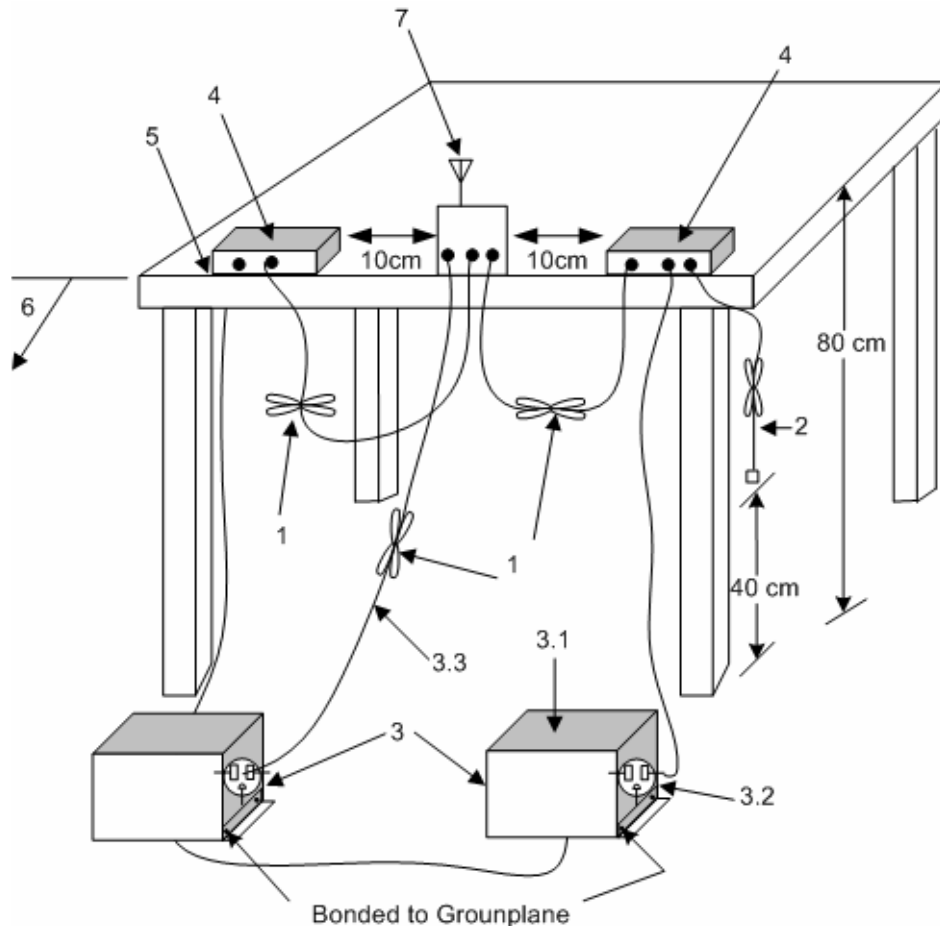

1. Interconnecting cables that hang closer than 40 cm to the ground plane shall be folded back and forth in the center forming a bundle 30 cm to 40 cm long see (see 6.2.3.2).
2. The I/O cables that are not connected to an accessory shall be bundled in the center. The end of the cable may be terminated, if required, using the correct terminating impedance. The overall length shall not exceed 1 m (see 6.2.2).
3. EUT connected to one LISN. Unused LISN measuring port connectors shall be terminated in 50 Ω loads. LISN may be placed on top of, or immediately beneath, reference ground plane (see 6.2.2 and 6.2.3).
 - 3.1 All other equipment powered from additional LISN(s).
 - 3.2 Multiple-outlet strip can be used for multiple power cords of non-EUT equipment.
 - 3.3 LISN at least 80 cm from nearest part of EUT chassis
4. Non-EUT components of EUT system being tested
5. Rear of EUT, including peripherals, shall all be aligned and flush with edge of tabletop (see 6.2.3.2).
6. Edge of tabletop shall be 40 cm removed from a vertical conducting plane that is bonded to the ground plane (see 6.2.2 for options).
7. Antenna may be integral or detachable. If detachable, the antenna shall be attached for this test.

Diagram 1 Test arrangement for Conducted emissions

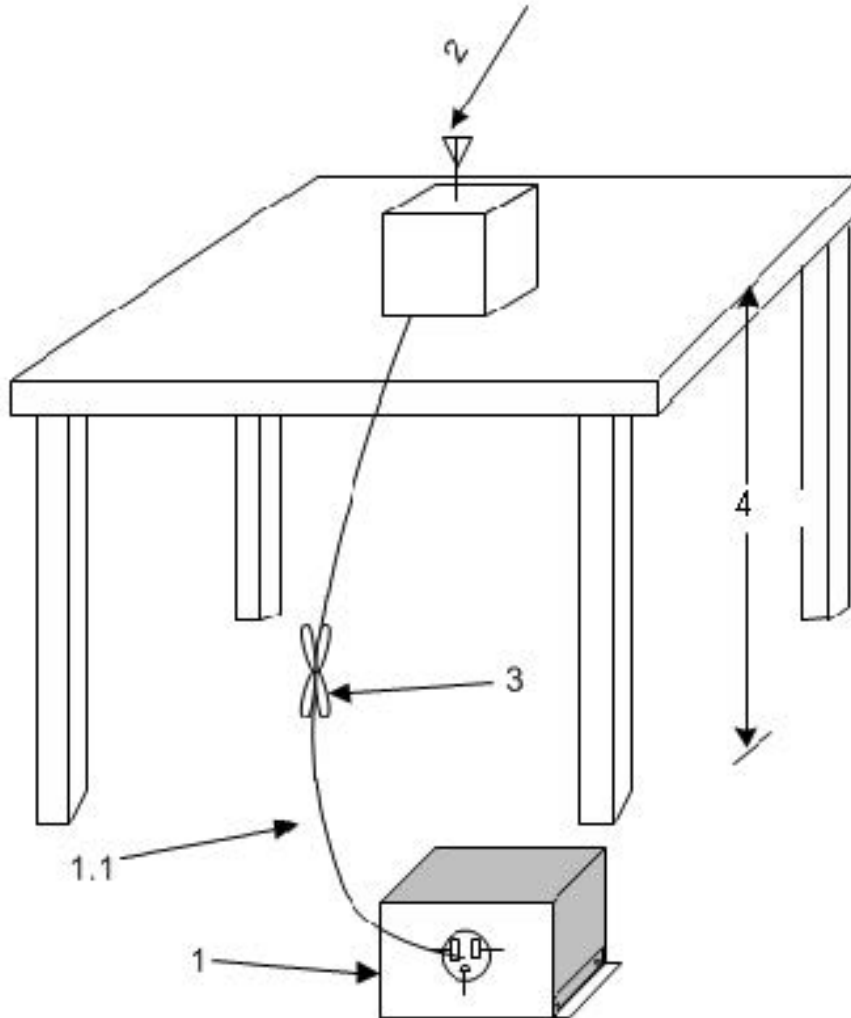

1. A LISN is optional for radiated measurements between 30 MHz and 1000 MHz but not allowed for measurements below 30 MHz and above 1000 MHz (see 6.3.1). If used, then connect EUT to one LISN. Unused LISN measuring port connectors shall be terminated in 50 Ω loads. The LISN may be placed on top of, or immediately beneath, the reference ground plane (see 6.2.2 and 6.2.3.2).
 - 1.1 LISN spaced at least 80 cm from nearest part of EUT chassis.
2. Antenna can be integral or detachable, depending on the EUT (see 6.3.1).
3. Interconnecting cables that hang closer than 40 cm to the ground plane shall be folded back and forth in the center forming a bundle 30 cm to 40 cm long (see 6.3.1).
4. For emission measurements at or below 1 GHz, the table height shall be 80 cm. For emission measurements above 1 GHz, the table height shall be 1.5 m for measurements, except as otherwise specified (see 6.3.1 and 6.6.3.1).

Diagram 2 Test arrangement for radiated emissions of tabletop equipment

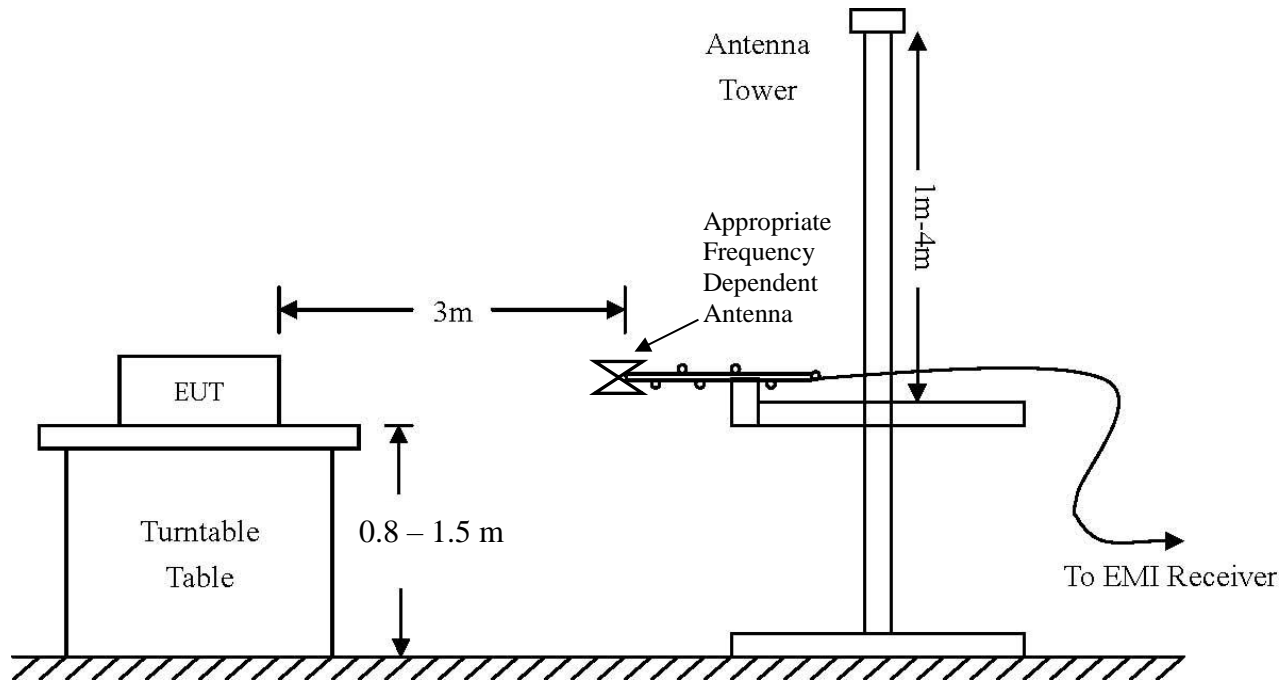

Frequency: 9 kHz-30 MHz	Frequency: 30 MHz- 1 GHz	Frequency: Above 1 GHz
Loop Antenna	Broadband Biconilog	Horn
RBW = 9 kHz	RBW = 120 kHz	RBW = 1 MHz
VBW = 30 kHz	VBW = 120 kHz	VBW = 1 MHz
Sweep time = Auto	Sweep time = Auto	Sweep time = Auto
Detector = PK, QP	Detector = PK, QP	Detector = PK, AV
Antenna Height 1m	Antenna Height 1-4m	Antenna Height 1-4m

Diagram 3 Test arrangement for radiated emissions tested on Open Area Test Site (OATS)

Test Site Locations

Conducted EMI The AC power line conducted emissions testing performed in a shielded screen room located at Rogers Labs, Inc., 4405 W. 259th Terrace, Louisburg, KS

Radiated EMI The radiated emissions tests were performed at the 3 meters, Open Area Test Site (OATS) located at Rogers Labs, Inc., 4405 W. 259th Terrace, Louisburg, KS

Site Registration Refer to Annex for Site Registration Letters

NVLAP Accreditation Lab code 200087-0

List of Test Equipment

A Rohde and Schwarz ESU40 and/or Hewlett Packard 8591EM was used as the measuring device for the emissions testing of frequencies below 1 GHz. A Rohde and Schwarz ESU40 and/or Hewlett Packard 8562A Spectrum Analyzer was used as the measuring device for testing the emissions at frequencies above 1 GHz. The analyzer settings used are described in the following table. Refer to the appendix for a complete list of test equipment.

AC Line Conducted Emissions (0.150 -30 MHz)		
RBW	AVG. BW	Detector Function
9 kHz	30 kHz	Peak / Quasi Peak
Emissions (30-1000 MHz)		
RBW	AVG. BW	Detector Function
120 kHz	300 kHz	Peak / Quasi Peak
Emissions (Above 1000 MHz)		
RBW	Video BW	Detector Function
100 kHz	100 kHz	Peak
1 MHz	1 MHz	Peak / Average

<input checked="" type="checkbox"/>	LISN	FCC	FCC-LISN-50-2-10(1PA) (160611)	.15-30MHz	5/16	5/17
<input checked="" type="checkbox"/>	Cable	Time Microwave	750HF290-750 (L10M)	9kHz-40 GHz	10/15	10/16
<input checked="" type="checkbox"/>	Cable	Belden	RG-58 (L1-CAT3-11509)	9kHz-30 MHz	10/15	10/16
<input checked="" type="checkbox"/>	Cable	Belden	RG-58 (L2-CAT3-11509)	9kHz-30 MHz	10/15	10/16
<input type="checkbox"/>	Antenna	ARA	BCD-235-B (169)	20-350MHz	10/15	10/16
<input type="checkbox"/>	Antenna	EMCO	3147 (40582)	200-1000MHz	10/15	10/16
<input checked="" type="checkbox"/>	Antenna	ETS-Lindgren	3117 (200389)	1-18 GHz	5/16	5/18
<input type="checkbox"/>	Antenna	Com Power	AH-118 (10110)	1-18 GHz	10/15	10/16
<input checked="" type="checkbox"/>	Antenna	Com Power	AH-840 (101046)	18-40 GHz	5/16	5/18
<input checked="" type="checkbox"/>	Antenna	EMCO	6509 (9502-1374)	.001-30 MHz	10/15	10/16
<input checked="" type="checkbox"/>	Antenna	Sunol	JB-6 (A100709)	30-1000 MHz	10/15	10/16
<input type="checkbox"/>	Antenna	EMCO	3143 (9607-1277)	20-1200 MHz	5/16	5/17
<input type="checkbox"/>	Analyzer	HP	8591EM (3628A00871)	9kHz-1.8GHz	5/16	5/17
<input type="checkbox"/>	Analyzer	HP	8562A (3051A05950)	9kHz-110GHz	5/16	5/17
<input type="checkbox"/>	Analyzer	HP External Mixers	11571, 11970	25GHz-110GHz	5/16	5/17
<input checked="" type="checkbox"/>	Analyzer	Rohde & Schwarz	ESU40 (100108)	20Hz-40GHz	5/16	5/17
<input checked="" type="checkbox"/>	Amplifier	Com-Power	PA-010 (171003)	100Hz-30MHz	10/15	10/16
<input checked="" type="checkbox"/>	Amplifier	Com-Power	CPPA-102 (01254)	1-1000 MHz	10/15	10/16
<input checked="" type="checkbox"/>	Amplifier	Com-Power	PAM-118A (551014)	0.5-18 GHz	10/15	10/16

Units of Measurements

Conducted EMI Data is in dB μ V; dB referenced to one microvolt

Radiated EMI Data is in dB μ V/m; dB/m referenced to one microvolt per meter

Sample Calculation:

RFS = Radiated Field Strength, FSM = Field Strength Measured

A.F. = Receive antenna factor, Gain = amplification gains and/or cable losses

RFS (dB μ V/m @ 3m) = FSM (dB μ V) + A.F. (dB) - Gain (dB)

Environmental Conditions

Ambient Temperature 23.4° C

Relative Humidity 45%

Atmospheric Pressure 1016.1 mb

Intentional Radiators

As per 47CFR part 15 subpart C, and Industry Canada RSS-247, Issue 1, the following information is submitted for consideration and demonstration of compliance with regulation and standards.

Antenna Requirements

The EUT incorporates MMCX antenna connection ports for use with authorized antenna systems only. The module is provided for incorporation into OEM equipment systems for use with authorized antenna systems. The requirements of 15.203 are fulfilled there are no deviations or exceptions to the specification.

Restricted Bands of Operation

Spurious emissions falling in the restricted frequency bands of operation were measured at the on the OATS. The EUT utilizes frequency, determining circuitry, which generates harmonics falling in restricted bands. Emissions were investigated at the antenna port and OATS, using appropriate antennas or pyramidal horns, amplification stages, and spectrum analyzer. Peak and average amplitudes of frequencies above 1000 MHz were compared to the required limits with worst-case data presented below. Test procedures of ANSI C63.10-2013 were used during testing. No other significant emission was observed which fell into the restricted bands of operation. Computed radiated emission values take into account the measured radiated field strength, receive antenna correction factor, amplifier gain stage, and test system cable losses.

Table 1 General Radiated Emissions in Restricted Bands Data (worst-case, 20 MHz, WLO-2450-15)

Frequency in MHz	Horizontal Peak (dBµV/m)	Horizontal Quasi-Peak (dBµV/m)	Horizontal Average (dBµV/m)	Vertical Peak (dBµV/m)	Vertical Quasi-Peak (dBµV/m)	Vertical Average (dBµV/m)	Limit @ 3m (dBµV/m)
2390.0	44.8	N/A	31.7	55.9	N/A	47.6	54.0
2483.5	46.3	N/A	31.1	58.0	N/A	49.9	54.0
4824.0	44.1	N/A	31.0	52.4	N/A	43.5	54.0
4874.0	45.6	N/A	32.0	44.6	N/A	31.9	54.0
4924.0	43.1	N/A	16.6	16.1	N/A	31.1	54.0
7236.0	45.3	N/A	32.5	43.7	N/A	31.3	54.0
7311.0	45.9	N/A	32.9	46.0	N/A	33.0	54.0
7386.0	45.7	N/A	16.6	16.1	N/A	32.8	54.0
12060.0	50.7	N/A	37.7	51.1	39.8	37.9	43.5
12185.0	50.3	N/A	37.5	50.5	32.5	37.6	43.5
12310.0	50.7	N/A	37.5	50.5	29.6	37.6	46.0
14472.0	52.1	N/A	39.1	51.6	26.7	39.0	46.0

Other emissions present had amplitudes at least 20 dB below the limit. Peak and Quasi-Peak amplitude emissions are recorded above for frequency range below 1000 MHz. Peak and Average amplitude emissions are recorded above for frequency range above 1000 MHz.

Table 2 General Radiated Emissions in Restricted Bands Data (worst-case, 40 MHz, WLO-2450-15)

Frequency in MHz	Horizontal Peak (dBµV/m)	Horizontal Quasi-Peak (dBµV/m)	Horizontal Average (dBµV/m)	Vertical Peak (dBµV/m)	Vertical Quasi-Peak (dBµV/m)	Vertical Average (dBµV/m)	Limit @ 3m (dBµV/m)
2390.0	51.5	N/A	33.5	70.2	N/A	52.0	54.0
2483.5	50.2	N/A	33.1	66.7	N/A	48.3	54.0
4844.0	43.7	N/A	30.8	43.2	N/A	30.8	54.0
4954.0	44.1	N/A	30.6	43.9	N/A	30.4	54.0
4904.0	43.5	N/A	30.7	44.1	N/A	30.6	54.0
7266.0	45.9	N/A	33.2	45.5	N/A	33.1	54.0
7431.0	44.5	N/A	31.1	45.5	N/A	32.4	54.0
7356.0	46.6	N/A	33.4	46.1	N/A	33.4	54.0
12110.0	50.3	N/A	37.9	51.5	39.8	38.0	43.5
12385.0	50.6	N/A	37.5	50.3	32.5	37.6	43.5
12260.0	50.1	N/A	37.8	50.5	29.6	37.8	46.0
14532.0	53.0	N/A	39.4	52.4	26.7	39.6	46.0

Other emissions present had amplitudes at least 20 dB below the limit. Peak and Quasi-Peak amplitude emissions are recorded above for frequency range below 1000 MHz. Peak and Average amplitude emissions are recorded above for frequency range above 1000 MHz.

Table 3 General Radiated Emissions in Restricted Bands Data (worst-case, 20 MHz, ODH-24-13)

Frequency in MHz	Horizontal Peak (dB μ V/m)	Horizontal Quasi-Peak (dB μ V/m)	Horizontal Average (dB μ V/m)	Vertical Peak (dB μ V/m)	Vertical Quasi-Peak (dB μ V/m)	Vertical Average (dB μ V/m)	Limit @ 3m (dB μ V/m)
2390.0	58.7	N/A	45.4	40.0	N/A	27.4	54.0
2483.5	63.2	N/A	50.7	40.4	N/A	27.8	54.0
4824.0	46.2	N/A	36.7	43.8	N/A	31.1	54.0
4874.0	44.2	N/A	31.0	44.3	N/A	31.6	54.0
4924.0	43.1	N/A	30.8	45.9	N/A	33.0	54.0
7236.0	45.6	N/A	32.8	45.4	N/A	32.9	54.0
7311.0	46.0	N/A	33.0	46.2	N/A	33.2	54.0
7386.0	46.1	N/A	33.2	46.0	N/A	33.1	54.0
12060.0	50.8	N/A	37.8	50.9	39.8	37.7	43.5
12185.0	50.5	N/A	37.5	50.8	32.5	37.5	43.5
12310.0	50.6	N/A	37.9	50.1	29.6	37.6	46.0
14472.0	52.0	N/A	39.2	51.7	26.7	39.0	46.0

Other emissions present had amplitudes at least 20 dB below the limit. Peak and Quasi-Peak amplitude emissions are recorded above for frequency range below 1000 MHz. Peak and Average amplitude emissions are recorded above for frequency range above 1000 MHz.

Table 4 General Radiated Emissions in Restricted Bands Data (worst-case, 40 MHz, ODH-24-13)

Frequency in MHz	Horizontal Peak (dB μ V/m)	Horizontal Quasi-Peak (dB μ V/m)	Horizontal Average (dB μ V/m)	Vertical Peak (dB μ V/m)	Vertical Quasi-Peak (dB μ V/m)	Vertical Average (dB μ V/m)	Limit @ 3m (dB μ V/m)
2390.0	68.7	N/A	52.2	40.7	N/A	27.0	54.0
2483.5	70.3	N/A	53.1	43.8	N/A	28.1	54.0
4844.0	43.9	N/A	30.6	43.0	N/A	30.7	54.0
4894.0	43.6	N/A	30.7	43.4	N/A	30.6	54.0
4904.0	43.7	N/A	30.7	44.5	N/A	30.8	54.0
7266.0	45.8	N/A	32.8	46.1	N/A	32.9	54.0
7341.0	43.5	N/A	30.5	43.1	N/A	30.6	54.0
7356.0	45.8	N/A	33.5	46.3	N/A	33.5	54.0
12110.0	50.3	N/A	37.9	51.2	39.8	38.3	43.5
12235.0	50.3	N/A	37.6	50.4	32.5	37.6	43.5
12260.0	50.6	N/A	38.0	50.5	29.6	37.7	46.0
14532.0	52.1	N/A	39.5	52.2	26.7	39.6	46.0

Other emissions present had amplitudes at least 20 dB below the limit. Peak and Quasi-Peak amplitude emissions are recorded above for frequency range below 1000 MHz. Peak and Average amplitude emissions are recorded above for frequency range above 1000 MHz.

Table 5 General Radiated Emissions in Restricted Bands Data (worst-case, 20 MHz, WLP-2450-20)

Frequency in MHz	Horizontal Peak (dBµV/m)	Horizontal Quasi-Peak (dBµV/m)	Horizontal Average (dBµV/m)	Vertical Peak (dBµV/m)	Vertical Quasi-Peak (dBµV/m)	Vertical Average (dBµV/m)	Limit @ 3m (dBµV/m)
2390.0	40.2	N/A	27.5	64.2	N/A	52.9	54.0
2483.5	41.0	N/A	27.6	52.9	N/A	39.0	54.0
4824.0	43.4	N/A	30.6	43.6	N/A	30.9	54.0
4874.0	43.3	N/A	30.9	44.2	N/A	31.4	54.0
4924.0	43.5	N/A	30.7	43.3	N/A	30.6	54.0
7236.0	45.8	N/A	32.9	46.1	N/A	32.9	54.0
7311.0	45.9	N/A	32.8	45.6	N/A	32.9	54.0
7386.0	45.4	N/A	33.0	45.7	N/A	32.9	54.0
12060.0	50.9	N/A	37.7	50.5	39.8	37.7	43.5
12185.0	50.3	N/A	37.7	50.7	32.5	37.7	43.5
12310.0	50.1	N/A	37.6	50.5	29.6	37.6	46.0
14472.0	52.3	N/A	39.1	52.7	26.7	39.1	46.0

Other emissions present had amplitudes at least 20 dB below the limit. Peak and Quasi-Peak amplitude emissions are recorded above for frequency range below 1000 MHz. Peak and Average amplitude emissions are recorded above for frequency range above 1000 MHz.

Table 6 General Radiated Emissions in Restricted Bands Data (worst-case, 40 MHz, WLP-2450-20)

Frequency in MHz	Horizontal Peak (dBµV/m)	Horizontal Quasi-Peak (dBµV/m)	Horizontal Average (dBµV/m)	Vertical Peak (dBµV/m)	Vertical Quasi-Peak (dBµV/m)	Vertical Average (dBµV/m)	Limit @ 3m (dBµV/m)
2390.0	41.6	N/A	28.2	71.1	N/A	53.4	54.0
2483.5	40.6	N/A	28.2	66.5	N/A	47.7	54.0
4844.0	43.6	N/A	30.8	43.4	N/A	30.7	54.0
4894.0	43.1	N/A	30.5	42.9	N/A	30.6	54.0
4904.0	43.3	N/A	30.7	43.8	N/A	30.8	54.0
7266.0	46.6	N/A	33.3	45.7	N/A	33.3	54.0
7341.0	46.1	N/A	33.2	45.3	N/A	33.0	54.0
7356.0	46.4	N/A	33.5	46.2	N/A	33.5	54.0
12110.0	50.8	N/A	38.0	50.6	39.8	37.9	43.5
12235.0	50.7	N/A	37.1	50.2	32.5	37.6	43.5
12260.0	50.3	N/A	37.8	51.1	29.6	37.8	46.0
14532.0	52.2	N/A	39.5	52.4	26.7	39.5	46.0

Other emissions present had amplitudes at least 20 dB below the limit. Peak and Quasi-Peak amplitude emissions are recorded above for frequency range below 1000 MHz. Peak and Average amplitude emissions are recorded above for frequency range above 1000 MHz.

Table 7 General Radiated Emissions in Restricted Bands Data (worst-case, 20 MHz, SA24-90-17-WB)

Frequency in MHz	Horizontal Peak (dBµV/m)	Horizontal Quasi-Peak (dBµV/m)	Horizontal Average (dBµV/m)	Vertical Peak (dBµV/m)	Vertical Quasi-Peak (dBµV/m)	Vertical Average (dBµV/m)	Limit @ 3m (dBµV/m)
2390.0	40.0	N/A	27.0	58.9	N/A	45.3	54.0
2483.5	41.1	N/A	27.6	59.7	N/A	47.6	54.0
4824.0	43.4	N/A	30.9	43.9	N/A	31.3	54.0
4874.0	44.4	N/A	31.2	45.6	N/A	32.6	54.0
4924.0	43.3	N/A	30.8	44.5	N/A	32.2	54.0
7236.0	44.6	N/A	31.3	43.4	N/A	31.3	54.0
7311.0	44.5	N/A	31.6	44.5	N/A	31.7	54.0
7386.0	44.7	N/A	32.1	45.6	N/A	32.2	54.0
12060.0	50.7	N/A	37.7	50.1	39.8	37.7	43.5
12185.0	50.4	N/A	37.6	50.2	32.5	37.7	43.5
12310.0	50.3	N/A	37.6	50.6	29.6	37.6	46.0
14472.0	51.8	N/A	39.0	51.8	26.7	39.0	46.0

Other emissions present had amplitudes at least 20 dB below the limit. Peak and Quasi-Peak amplitude emissions are recorded above for frequency range below 1000 MHz. Peak and Average amplitude emissions are recorded above for frequency range above 1000 MHz.

Table 8 General Radiated Emissions in Restricted Bands Data (worst-case, 40 MHz, SA24-90-17-WB)

Frequency in MHz	Horizontal Peak (dBµV/m)	Horizontal Quasi-Peak (dBµV/m)	Horizontal Average (dBµV/m)	Vertical Peak (dBµV/m)	Vertical Quasi-Peak (dBµV/m)	Vertical Average (dBµV/m)	Limit @ 3m (dBµV/m)
2390.0	40.2	N/A	27.0	70.2	N/A	52.2	54.0
2483.5	40.4	N/A	27.3	58.9	N/A	45.4	54.0
4844.0	43.7	N/A	30.5	43.2	N/A	30.6	54.0
4894.0	43.3	N/A	30.3	43.1	N/A	30.5	54.0
4904.0	43.8	N/A	30.7	43.3	N/A	30.8	54.0
7266.0	45.8	N/A	33.3	46.1	N/A	33.3	54.0
7341.0	45.7	N/A	32.9	45.8	N/A	33.0	54.0
7356.0	44.1	N/A	31.0	43.7	N/A	31.1	54.0
12110.0	50.2	N/A	37.8	50.4	39.8	37.8	43.5
12235.0	50.3	N/A	37.6	50.8	32.5	37.6	43.5
12260.0	50.1	N/A	37.6	51.1	29.6	37.6	46.0
14532.0	52.1	N/A	39.9	53.0	26.7	39.4	46.0

Other emissions present had amplitudes at least 20 dB below the limit. Peak and Quasi-Peak amplitude emissions are recorded above for frequency range below 1000 MHz. Peak and Average amplitude emissions are recorded above for frequency range above 1000 MHz.

Table 9 General Radiated Emissions in Restricted Bands Data (worst-case, 20 MHz, DC 24-HD-PFIP)

Frequency in MHz	Horizontal Peak (dBµV/m)	Horizontal Quasi-Peak (dBµV/m)	Horizontal Average (dBµV/m)	Vertical Peak (dBµV/m)	Vertical Quasi-Peak (dBµV/m)	Vertical Average (dBµV/m)	Limit @ 3m (dBµV/m)
2390.0	41.2	N/A	28.2	62.9	N/A	50.7	54.0
2483.5	42.2	N/A	29.1	64.9	N/A	51.2	54.0
4824.0	43.5	N/A	30.5	44.5	N/A	34.1	54.0
4874.0	44.0	N/A	30.9	43.9	N/A	30.8	54.0
4924.0	43.5	N/A	30.4	43.8	N/A	30.9	54.0
7236.0	45.7	N/A	32.7	45.4	N/A	32.8	54.0
7311.0	46.1	N/A	33.2	46.1	N/A	33.1	54.0
7386.0	46.0	N/A	33.2	46.0	N/A	33.3	54.0
12060.0	50.2	N/A	37.7	50.1	39.8	37.7	43.5
12185.0	50.1	N/A	37.4	50.3	32.5	37.4	43.5
12310.0	50.1	N/A	37.5	50.0	29.6	37.5	46.0
14472.0	51.5	N/A	39.0	51.8	26.7	39.0	46.0

Other emissions present had amplitudes at least 20 dB below the limit. Peak and Quasi-Peak amplitude emissions are recorded above for frequency range below 1000 MHz. Peak and Average amplitude emissions are recorded above for frequency range above 1000 MHz.

Table 10 General Radiated Emissions in Restricted Bands Data (worst-case, 40 MHz, DC 24-HD-PFIP)

Frequency in MHz	Horizontal Peak (dBµV/m)	Horizontal Quasi-Peak (dBµV/m)	Horizontal Average (dBµV/m)	Vertical Peak (dBµV/m)	Vertical Quasi-Peak (dBµV/m)	Vertical Average (dBµV/m)	Limit @ 3m (dBµV/m)
2390.0	42.6	N/A	29.1	64.2	N/A	50.8	54.0
2483.5	39.8	N/A	27.2	69.2	N/A	53.0	54.0
4844.0	43.7	N/A	30.7	44.0	N/A	30.7	54.0
4894.0	43.5	N/A	30.5	44.0	N/A	30.6	54.0
4904.0	43.5	N/A	30.7	43.7	N/A	30.8	54.0
7266.0	45.2	N/A	32.3	44.7	N/A	32.3	54.0
7341.0	46.3	N/A	32.2	44.9	N/A	32.2	54.0
7356.0	45.9	N/A	33.2	46.2	N/A	33.0	54.0
12110.0	50.8	N/A	37.7	50.1	39.8	37.7	43.5
12235.0	50.0	N/A	37.5	50.1	32.5	37.5	43.5
12260.0	51.1	N/A	37.9	50.2	29.6	37.6	46.0
14532.0	52.2	N/A	39.4	52.8	26.7	39.4	46.0

Other emissions present had amplitudes at least 20 dB below the limit. Peak and Quasi-Peak amplitude emissions are recorded above for frequency range below 1000 MHz. Peak and Average amplitude emissions are recorded above for frequency range above 1000 MHz.

Summary of Results for Radiated Emissions in Restricted Bands

The EUT demonstrated compliance with the emissions requirements of 47CFR 15.205, RSS-GEN and RSS-247, Issue 1 Intentional Radiators. The EUT provided a worst-case minimum margin of -0.6 dB below the emissions requirements in restricted frequency bands. Peak, Quasi-peak, and average amplitudes were checked for compliance with the regulations. Worst-case emissions are reported with other emissions found in the restricted frequency bands at least 20 dB below the requirements.

AC Line Conducted Emissions Procedure

The EUT was arranged in a typical equipment configuration and placed on a 1 x 1.5-meter wooden bench 80 cm above the conducting ground plane, floor of a screen room. The bench was positioned 40 cm away from the wall of the screen room. The LISN was positioned on the floor of the screen room 80-cm from the rear of the EUT. Testing for the line-conducted emissions were the procedures of ANSI C63.10-2013 paragraph 6. The AC adapter for the EUT was connected to the LISN for line-conducted emissions testing. A second LISN was positioned on the floor of the screen room 80-cm from the rear of the supporting equipment of the EUT. All power cords except the EUT were then powered from the second LISN. EMI was coupled to the spectrum analyzer through a 0.1 µF capacitor, internal to the LISN. Power line conducted emissions testing were carried out individually for each current carrying conductor of the EUT support equipment. The excess length of lead between the system and the LISN receptacle was folded back and forth to form a bundle not exceeding 40 cm in length. The screen room, conducting ground plane, analyzer, and LISN were bonded together to the protective earth ground. Preliminary testing was performed to identify the frequency of each emission displaying the highest amplitude. The cables were repositioned to obtain maximum amplitude of measured EMI level. Once the worst-case configuration was identified, plots were made of the EMI from 0.15 MHz to 30 MHz then the data was recorded with maximum conducted emissions levels. Refer to figures one and two for plots of the EUT support equipment AC Line Conducted emissions.

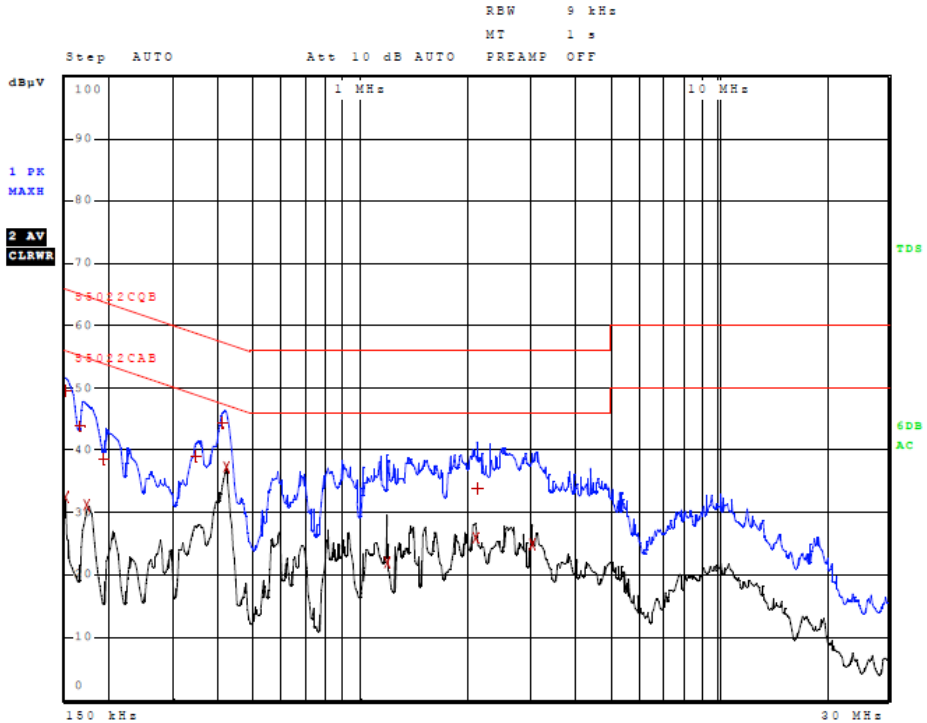

Figure 1 AC Line Conducted Emissions Line 1

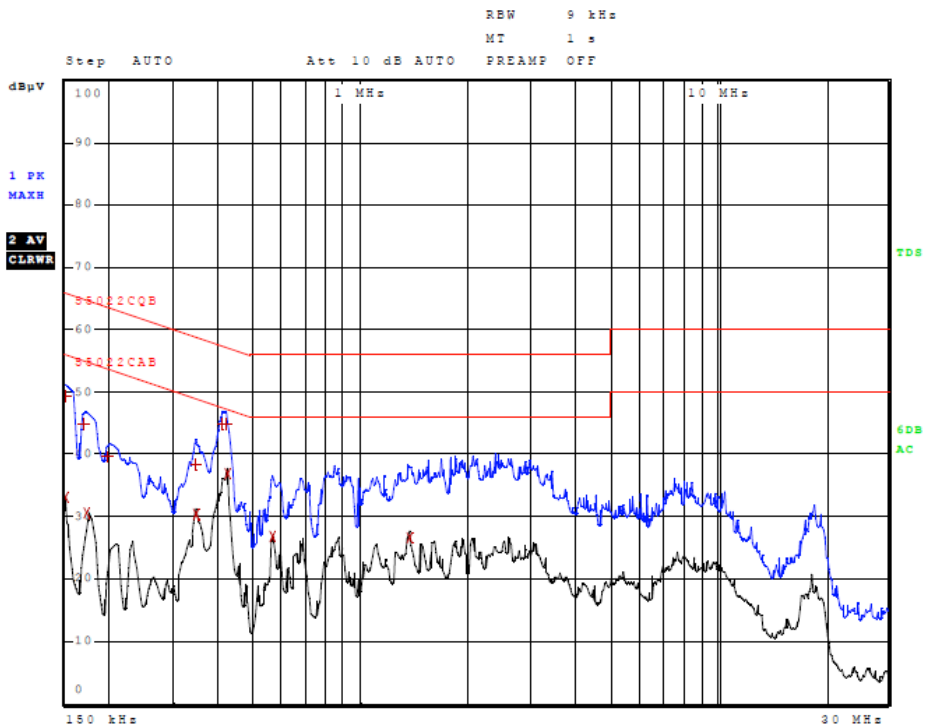

Figure 2 AC Line Conducted Emissions Line 2

Table 11 AC Line Conducted Emissions Data (Highest Emissions Line L1)

Trace	Frequency	Level (dBµV)	Detector	Delta Limit/dB
1	150.000000000 kHz	49.58	Quasi Peak	-16.42
2	150.000000000 kHz	32.46	Average	-23.54
1	166.000000000 kHz	43.80	Quasi Peak	-21.36
2	174.000000000 kHz	31.23	Average	-23.53
1	194.000000000 kHz	38.58	Quasi Peak	-25.28
1	350.000000000 kHz	39.01	Quasi Peak	-19.95
1	414.000000000 kHz	44.37	Quasi Peak	-13.19
2	418.000000000 kHz	37.30	Average	-10.18
2	1.190000000 MHz	22.04	Average	-23.96
2	2.098000000 MHz	25.97	Average	-20.03
1	2.114000000 MHz	33.87	Quasi Peak	-22.13
2	3.034000000 MHz	24.97	Average	-21.03

Other emissions present had amplitudes at least 20 dB below the limit.

Table 12 AC Line Conducted Emissions Data (Highest Emissions Line L2)

Trace	Frequency	Level (dBµV)	Detector	Delta Limit/dB
1	150.000000000 kHz	49.31	Quasi Peak	-16.69
2	150.000000000 kHz	33.13	Average	-22.87
1	170.000000000 kHz	44.93	Quasi Peak	-20.03
2	174.000000000 kHz	30.62	Average	-24.15
1	198.000000000 kHz	39.69	Quasi Peak	-24.00
2	346.000000000 kHz	30.44	Average	-18.61
1	346.000000000 kHz	38.43	Quasi Peak	-20.63
1	414.000000000 kHz	44.91	Quasi Peak	-12.66
1	418.000000000 kHz	44.78	Quasi Peak	-12.70
2	422.000000000 kHz	36.94	Average	-10.47
2	566.000000000 kHz	26.81	Average	-19.19
2	1.374000000 MHz	26.63	Average	-19.37

Other emissions present had amplitudes at least 20 dB below the limit.

Summary of Results for AC Line Conducted Emissions

The EUT test system demonstrated compliance to the conducted emissions requirements of 47CFR 15.207, RSS-247 Issue 1 and RSS-GEN. The EUT demonstrated minimum margin of -10.1 dB below the limit. Measurements were taken using the peak, quasi peak, and average, measurement function for each emissions amplitude and were below the limits stated in the specification. Other emissions were present with recorded data representing worst-case amplitudes.

General Radiated Emissions Procedure

The EUT was arranged in a typical equipment configuration and operated through all available modes with worst-case data recorded. Preliminary testing was performed in a screen room with the EUT positioned 1 meter from the FSM. Radiated emissions measurements were performed to identify the frequencies, which produced the highest emissions. Each radiated emission was then maximized at the OATS location before final radiated emissions measurements were performed. Final data was taken with the EUT located at the OATS at a distance of 3 meters between the EUT and the receiving antenna. The frequency spectrum from 9 kHz to 25,000 MHz was searched for general radiated emissions. Measured emission levels were maximized by EUT placement on the table, rotating the turntable through 360 degrees, varying the antenna height between 1 and 4 meters above the ground plane and changing antenna position between horizontal and vertical polarization. Antennas used were Loop from 9 kHz to 30 MHz, Broadband Biconical from 30 to 200 MHz, Biconilog from 30 to 1000 MHz, Log Periodic from 200 MHz to 1 GHz and or Double Ridge or pyramidal horns and mixers from 1 GHz to 25 GHz, notch filters, and appropriate amplifiers and external mixers were utilized.

Table 13 General Radiated Emissions from EUT Data (Highest Emissions)

Frequency in MHz	Horizontal Peak (dBµV/m)	Horizontal Quasi-Peak (dBµV/m)	Horizontal Average (dBµV/m)	Vertical Peak (dBµV/m)	Vertical Quasi-Peak (dBµV/m)	Vertical Average (dBµV/m)	Limit @ 3m (dBµV/m)
51.8	34.2	30.6	N/A	30.9	26.2	N/A	40.0
84.4	38.9	34.9	N/A	40.9	38.5	N/A	40.0
137.2	33.7	29.2	N/A	31.1	26.6	N/A	43.5
148.1	41.4	37.6	N/A	34.3	30.2	N/A	43.5
166.7	45.1	42.7	N/A	43.1	40.5	N/A	43.5
183.8	35.0	30.5	N/A	29.7	21.4	N/A	43.5
200.0	46.2	43.3	N/A	40.2	37.2	N/A	43.5
256.8	35.6	31.6	N/A	31.5	25.5	N/A	46.0
500.0	47.0	44.5	N/A	37.2	34.1	N/A	46.0
533.3	50.3	45.2	N/A	43.4	38.2	N/A	46.0
566.7	49.8	45.5	N/A	44.2	38.9	N/A	46.0
600.0	48.4	45.8	N/A	37.8	34.7	N/A	46.0

Other emissions present had amplitudes at least 20 dB below the limit. Peak and Quasi-Peak amplitude emissions are recorded above for frequency range below 1000 MHz. Peak and Average amplitude emissions are recorded above for frequency range above 1000 MHz.

Summary of Results for General Radiated Emissions

The EUT demonstrated compliance with the radiated emissions requirements of 47CFR part 15 and Industry Canada RSS-247 Issue 1 Intentional Radiators. The EUT demonstrated a minimum margin of -1.2 dB below the requirements. Other emissions were present with amplitudes at least 20 dB below the Limits.

Operation in the 2400-2483.5 MHz Frequency Band

Radiated emissions were measured on the Open Area Test Site (OATS) at a three-meter distance. The EUT provides MMCX antenna port connectors for use with authorized antenna systems as documented in this filing. Antenna port conducted emissions were taken for each chain and operational mode. Radiated emissions measurements were performed on the test sample with one chain loaded with 50-ohm load and the other connected to the transmit antenna. EUT was placed on a turntable elevated as required above the ground plane at a distance of 3 meters from the FSM antenna located on the OATS. The peak and quasi-peak amplitude of the frequencies below 1000 MHz were measured using a spectrum analyzer. The peak and average amplitude of emissions above 1000 MHz were measured using a spectrum analyzer. Emissions data was recorded from the measurement results. Data presented in this report reflects measurement result corrected to account for measurement system gains and losses. Worst-case radiated emissions are provided for each antenna type. Antenna port conducted plots were made of transmitter performance for reference purposes.

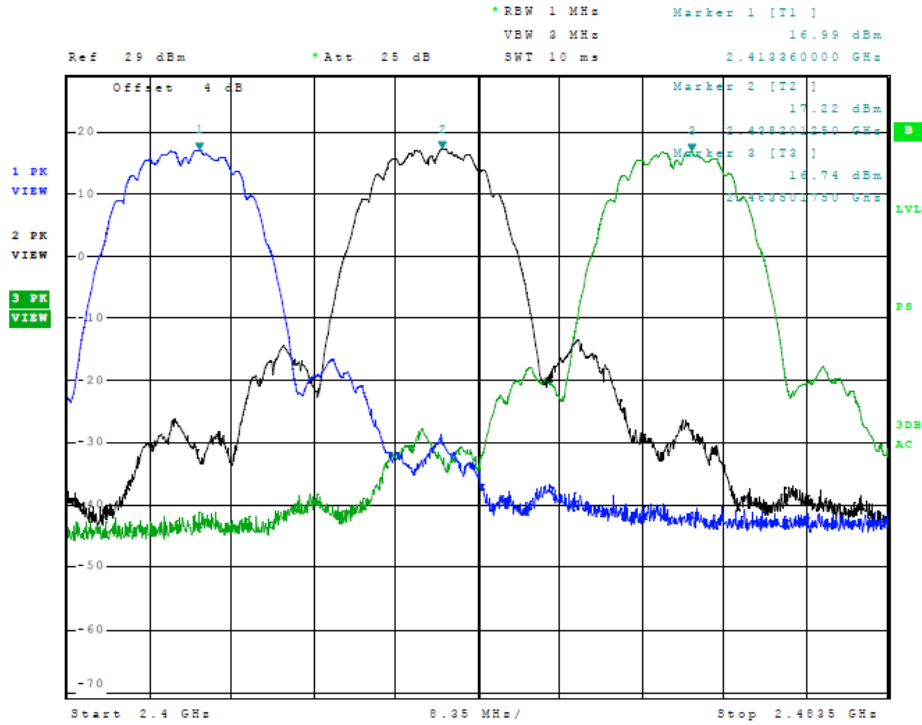

Figure 3 Plot of Transmitter Emissions (Across Operational Band 802.11b, Chain 0)

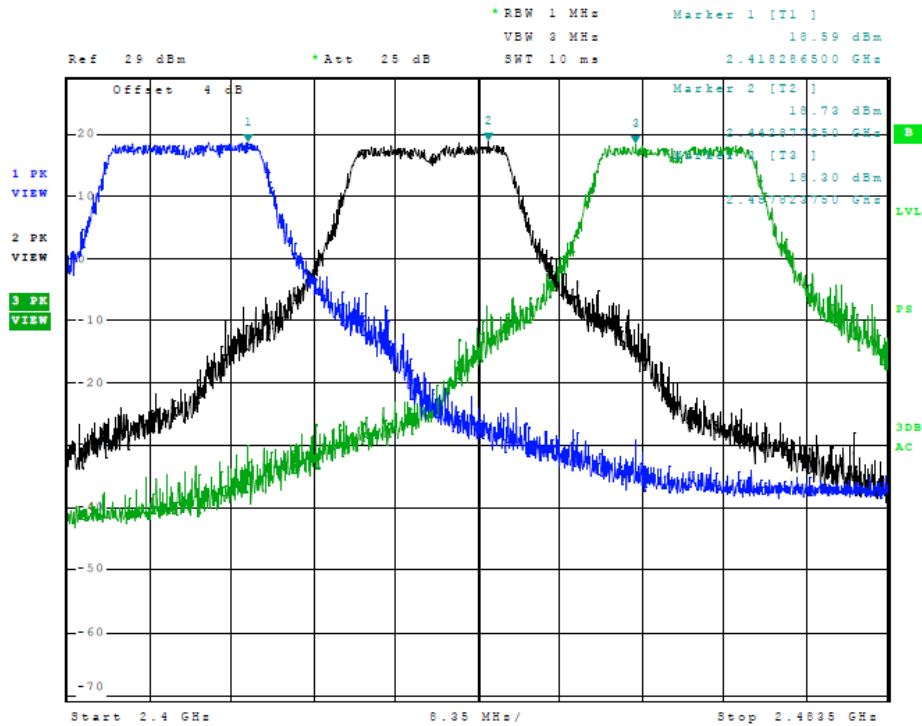

Figure 4 Plot of Transmitter Emissions (Across Operational Band, 802.11g, Chain 0)

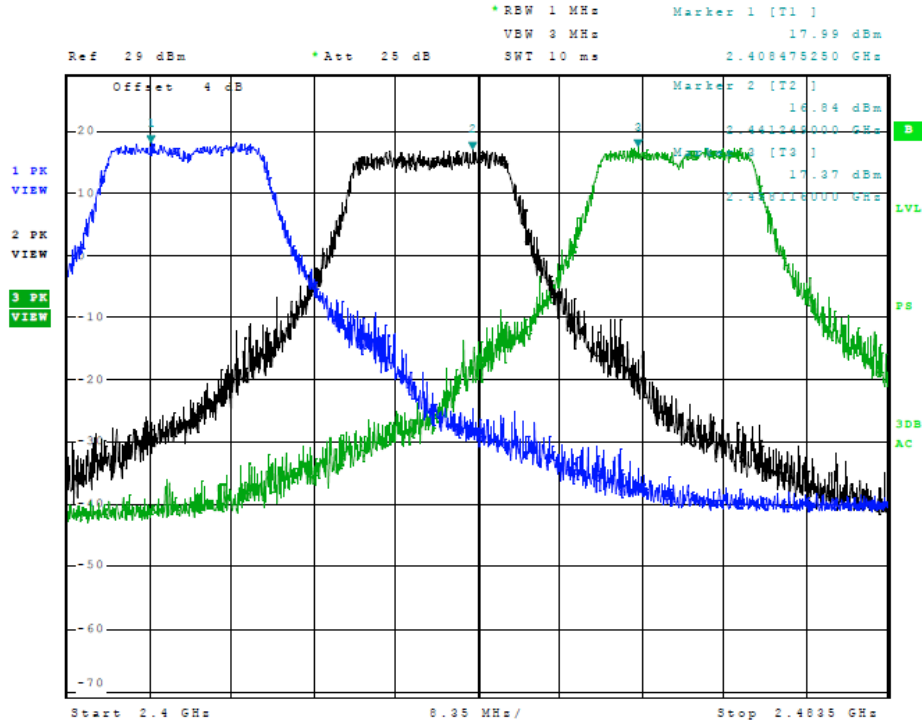

Figure 5 Plot of Transmitter Emissions (Across Operational Band, 802.11n (HT20), Chain 0)

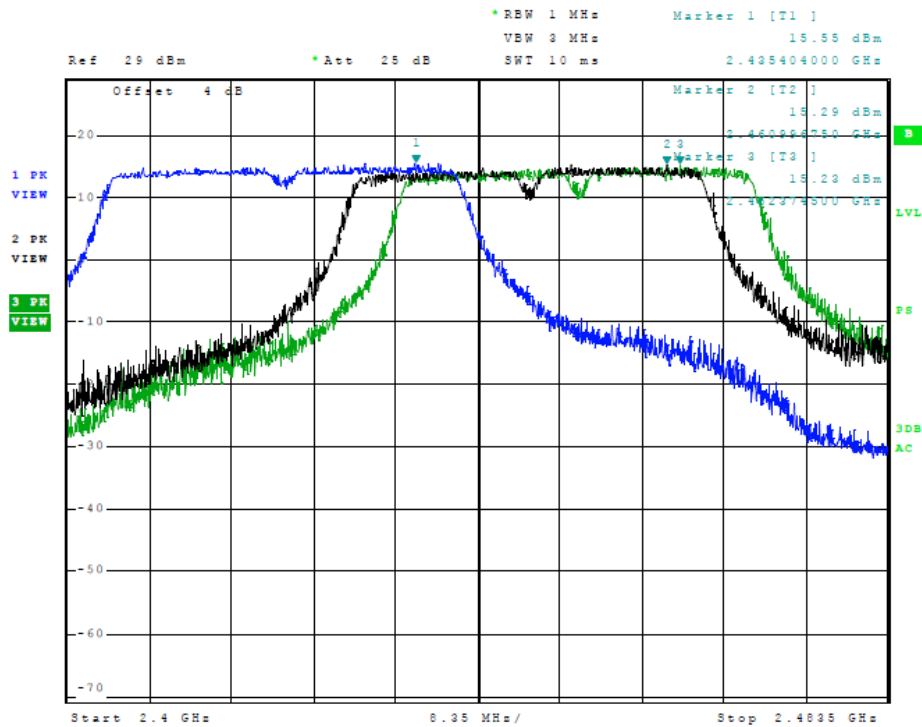

Figure 6 Plot of Transmitter Emissions (Across Operational Band, 802.11n (40), Chain 0)

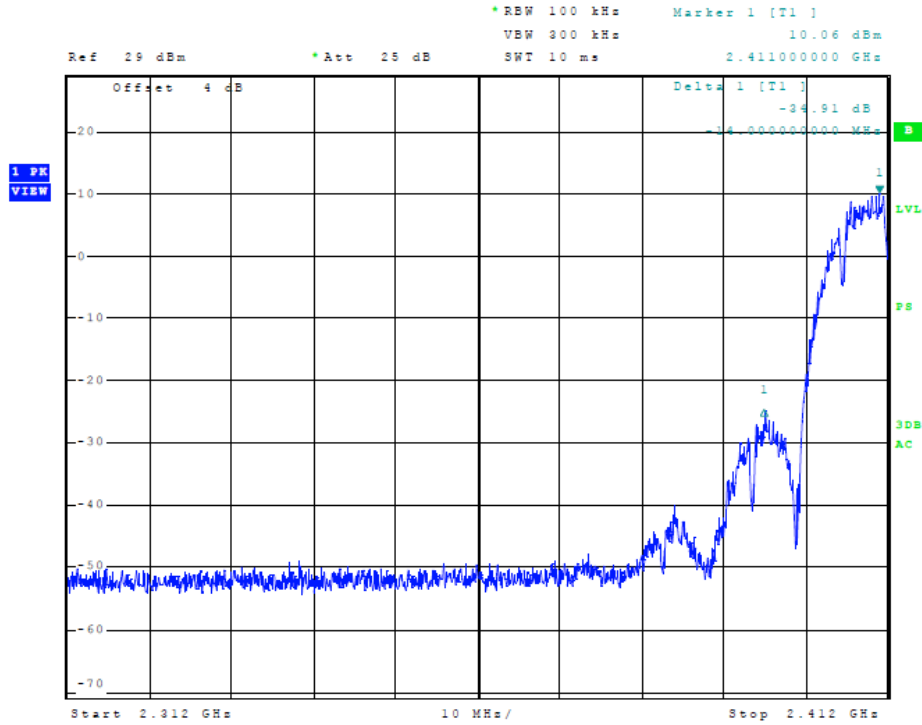

Figure 7 Plot of Transmitter Low Band Edge (802.11b, Chain 0)

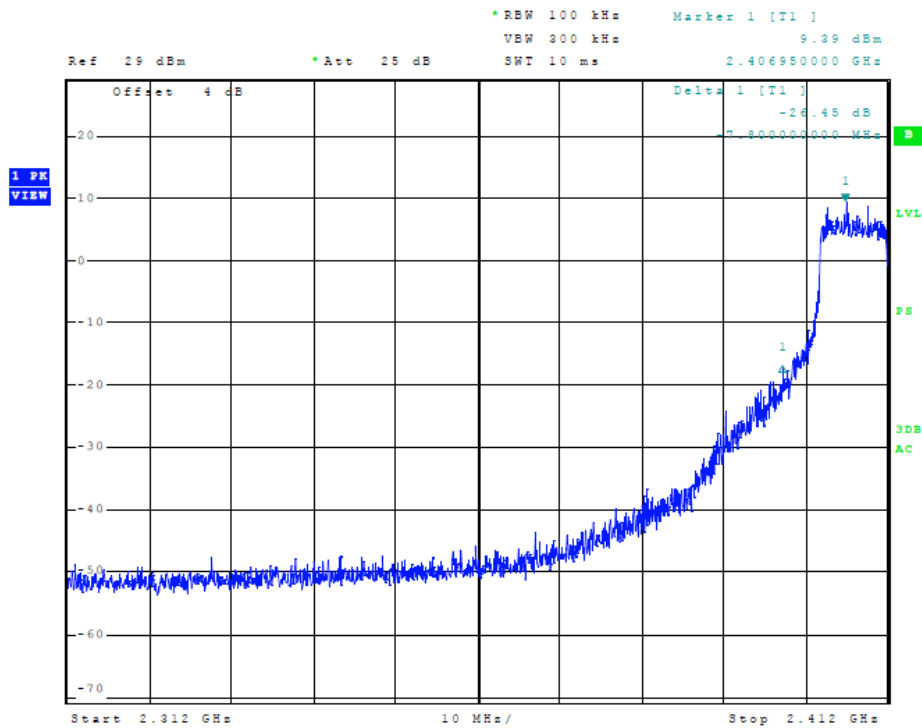

Figure 8 Plot of Transmitter Low Band Edge (802.11g, Chain 0)

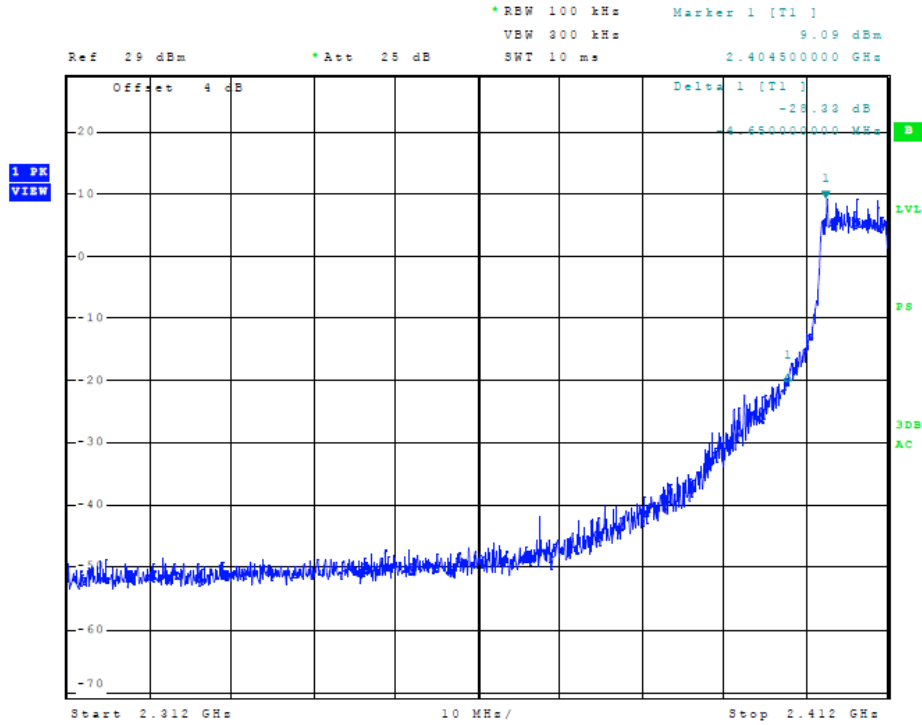

Figure 9 Plot of Transmitter Low Band Edge (802.11n (HT20), Chain 0)

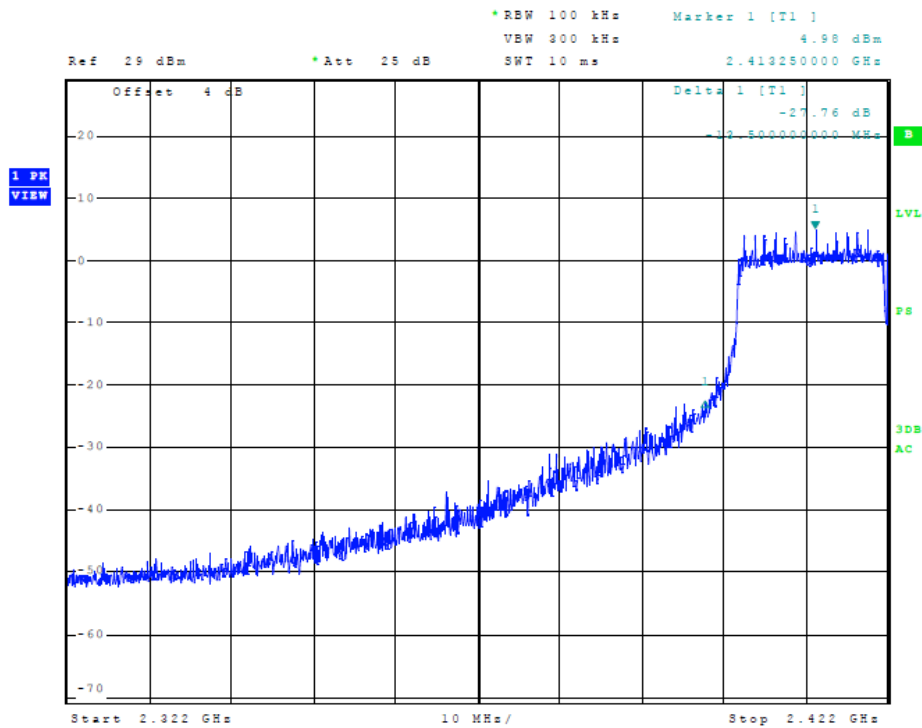

Figure 10 Plot of Transmitter Low Band Edge (802.11n (40), Chain 0)

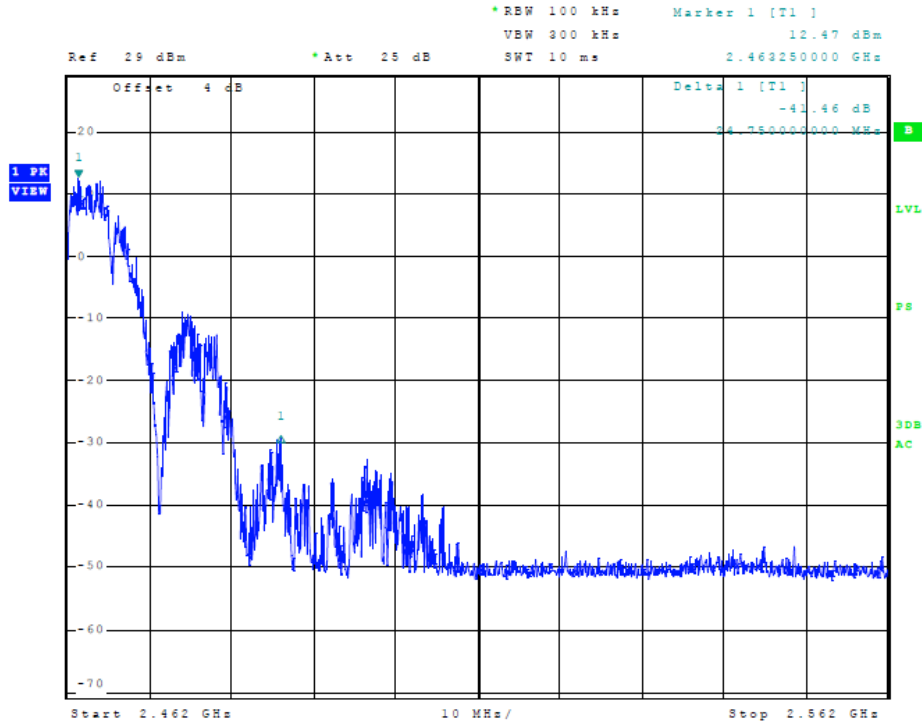

Figure 11 Plot of Transmitter High Band Edge (802.11b, Chain 0)

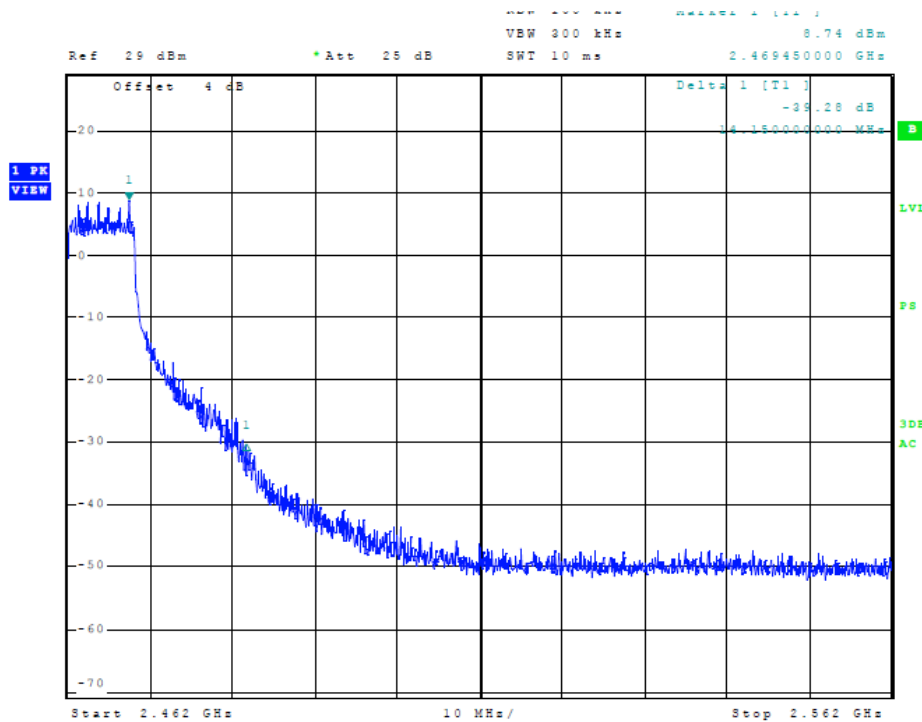

Figure 12 Plot of Transmitter High Band Edge (802.11g, Chain 0)

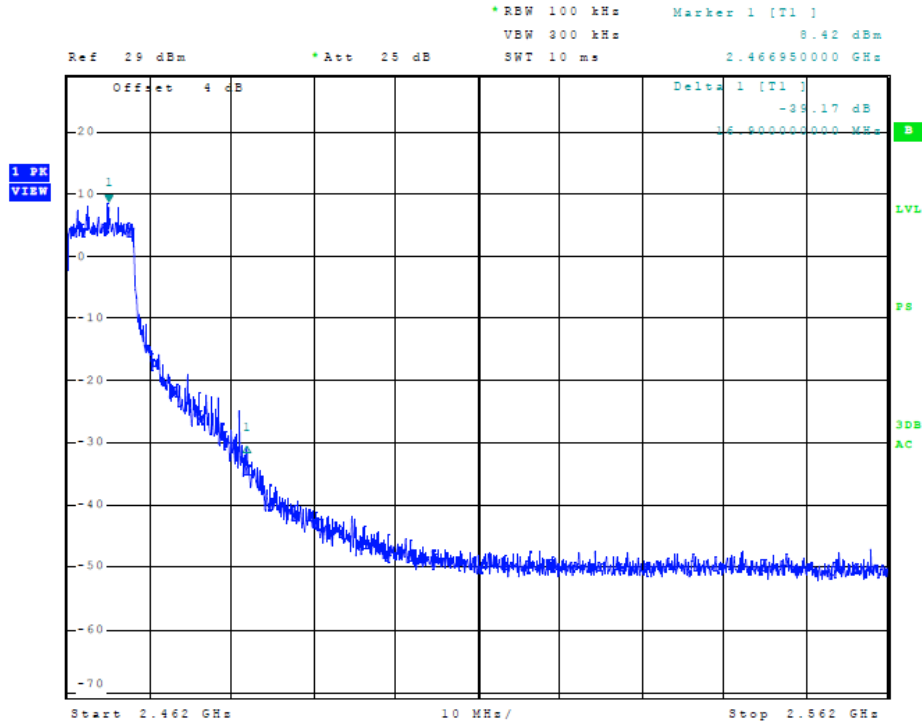

Figure 13 Plot of Transmitter High Band Edge (802.11n (HT20), Chain 0)

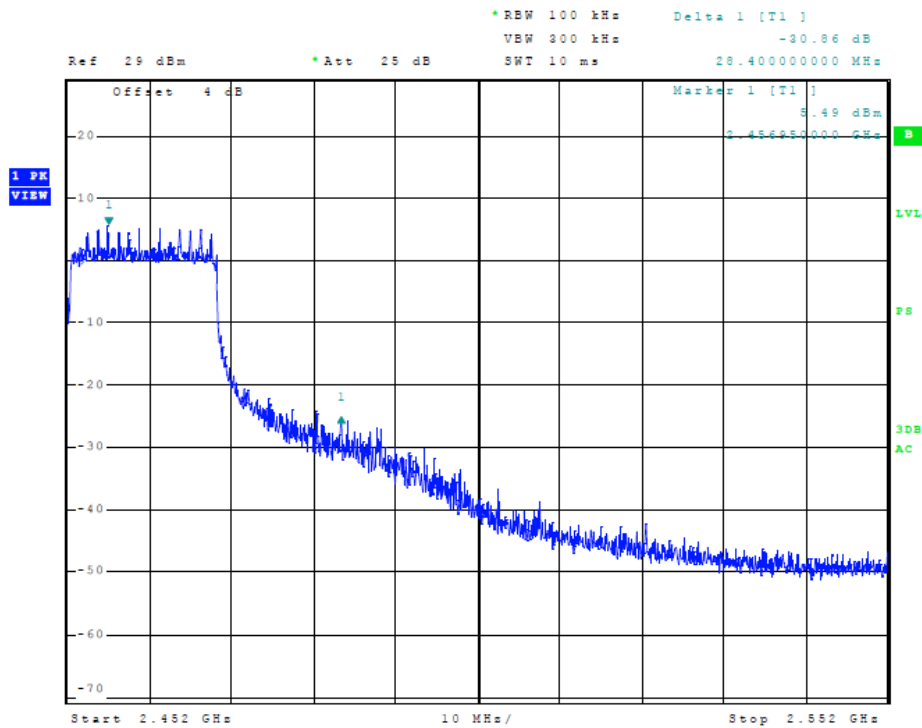

Figure 14 Plot of Transmitter High Band Edge (802.11n (40), Chain 0)

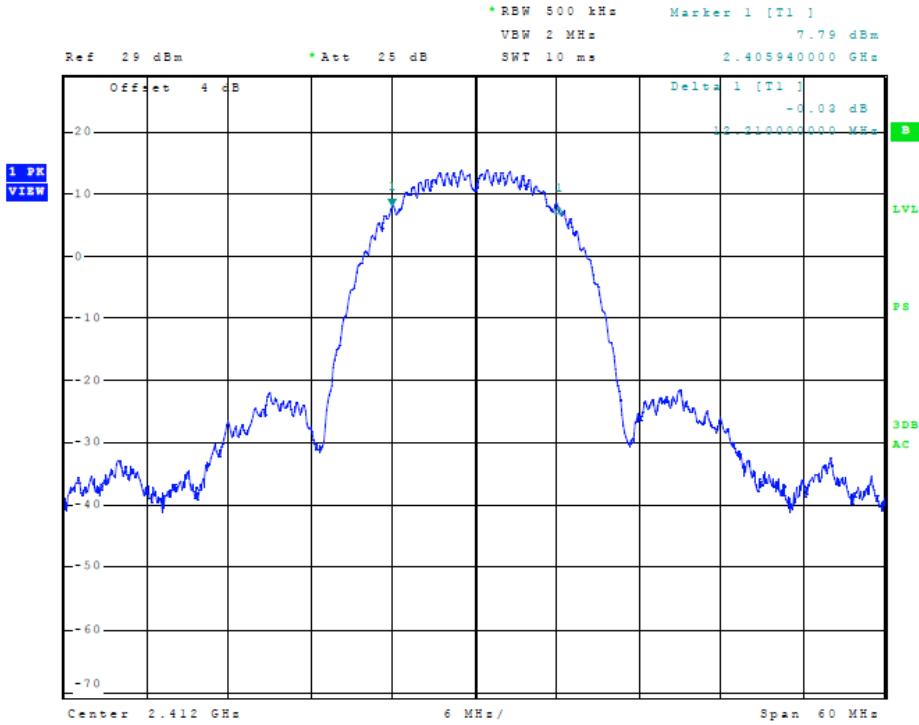

Figure 15 Plot of Transmitter 6-dB Occupied Band Width (802.11b, Chain 0)

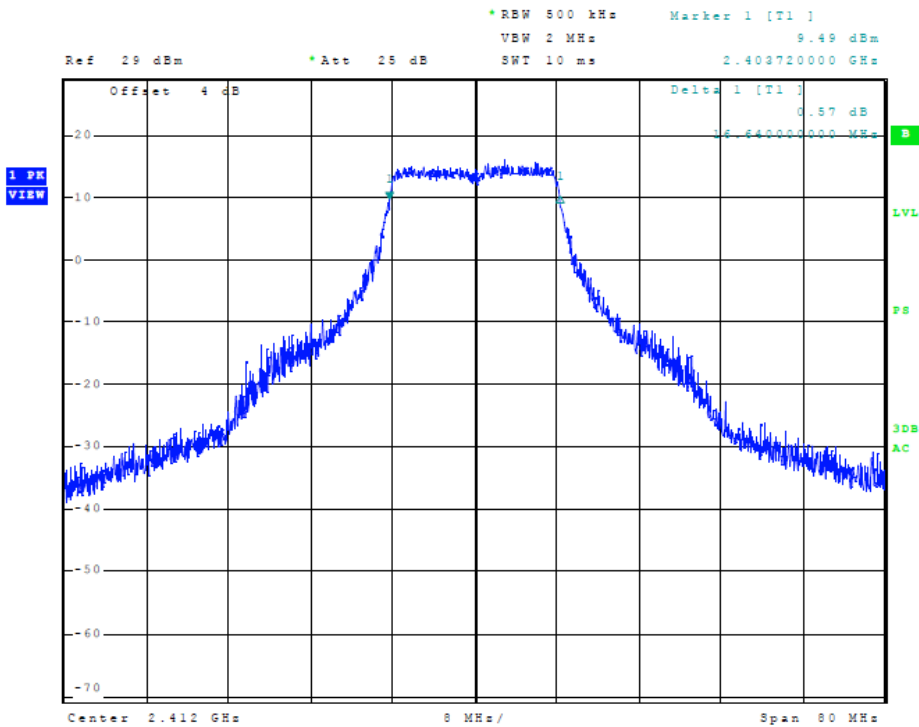

Figure 16 Plot of Transmitter 6-dB Occupied Band Width (802.11g, Chain 0)

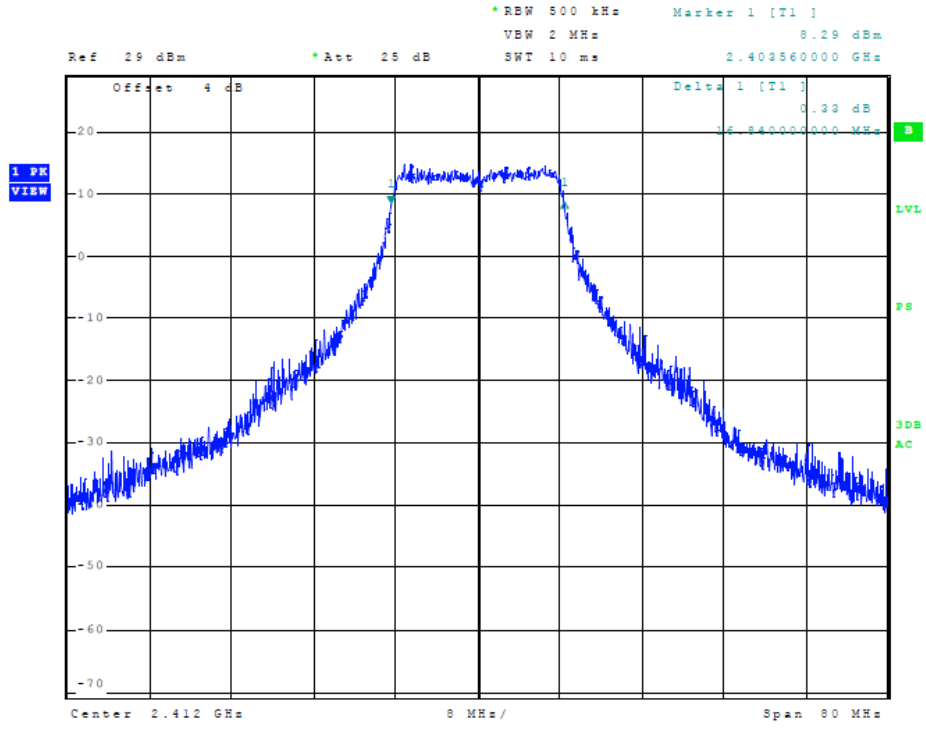

Figure 17 Plot of Transmitter 6-dB Occupied Band Width (802.11n, (HT20) Chain 0)

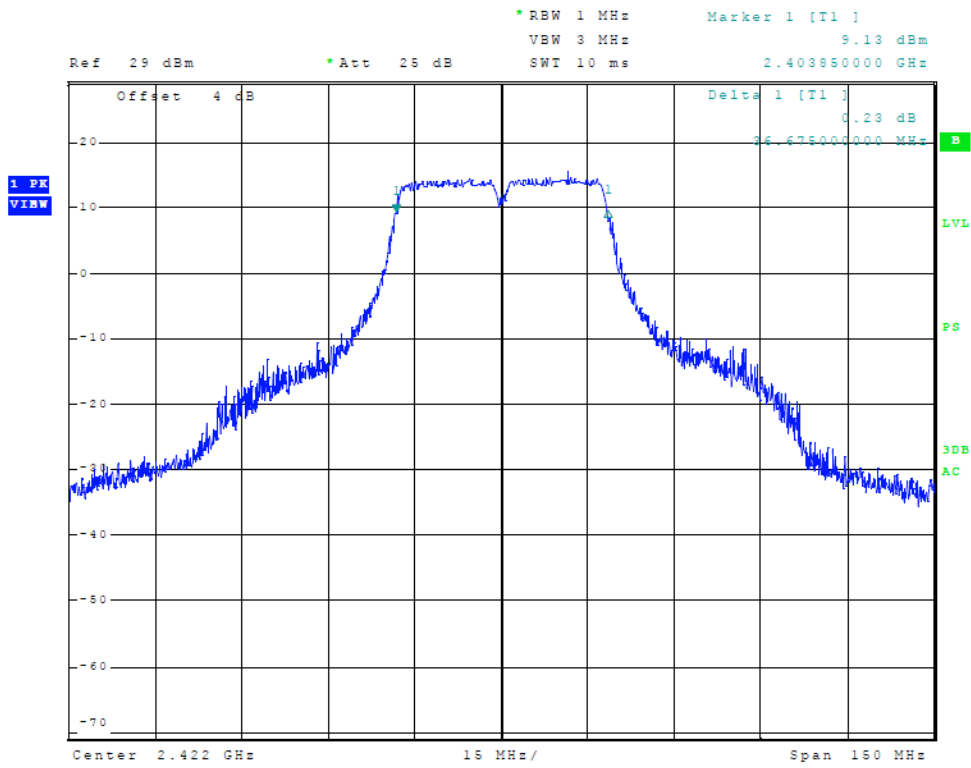

Figure 18 Plot of Transmitter 6-dB Occupied Band Width (802.11n (40), Chain 0)

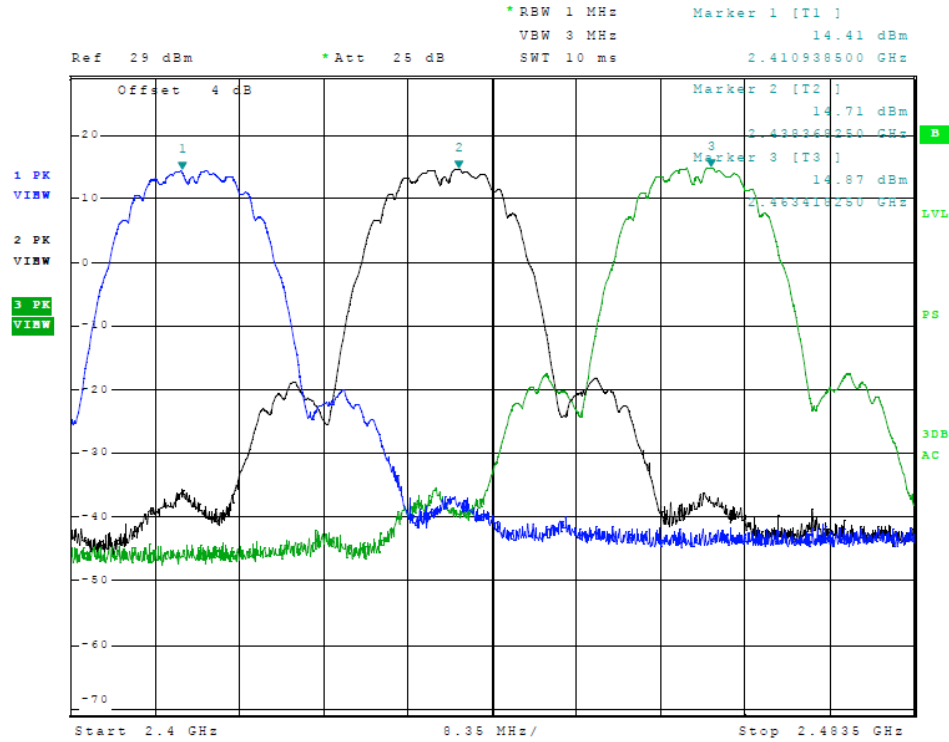

Figure 19 Plot of Transmitter Emissions (Across Operational Band 802.11b, Chain 1)

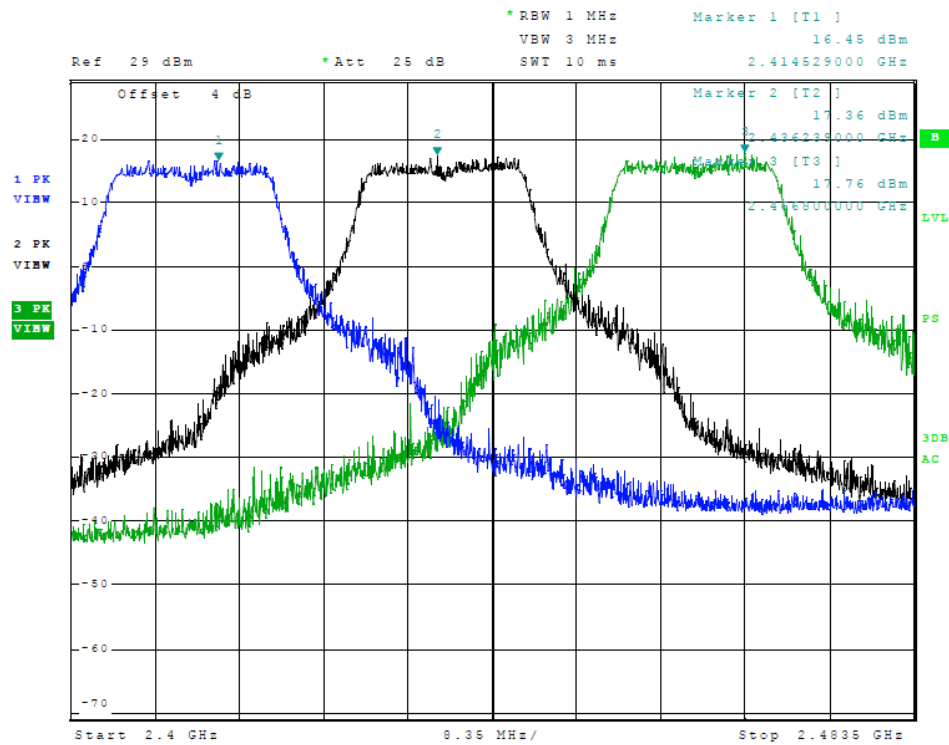

Figure 20 Plot of Transmitter Emissions (Across Operational Band, 802.11g, Chain 1)

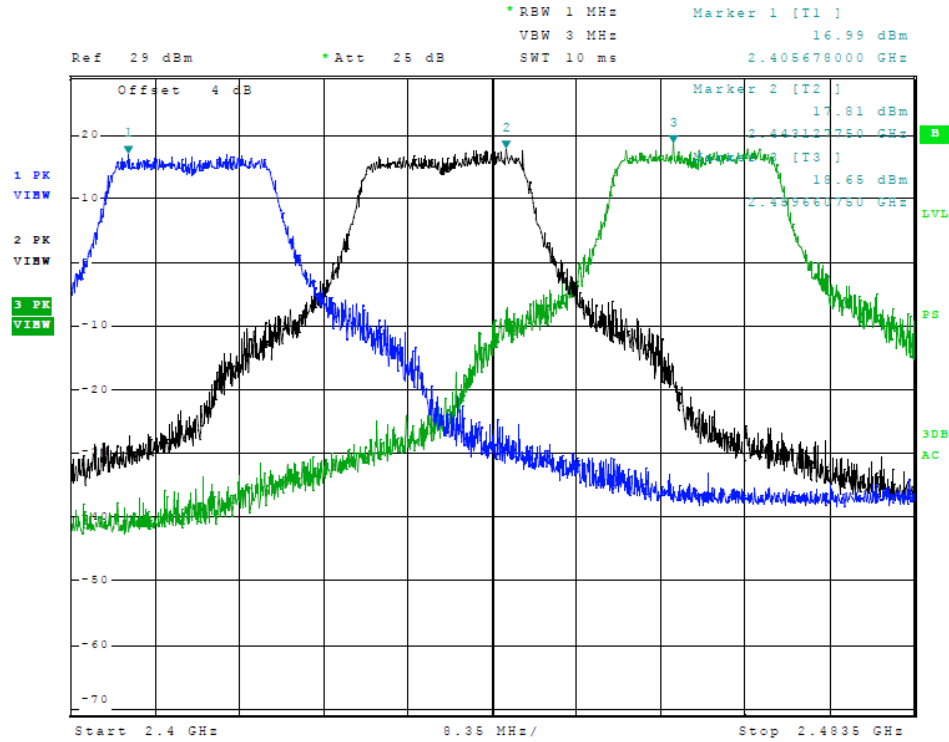

Figure 21 Plot of Transmitter Emissions (Across Operational Band, 802.11n (20), Chain 1)

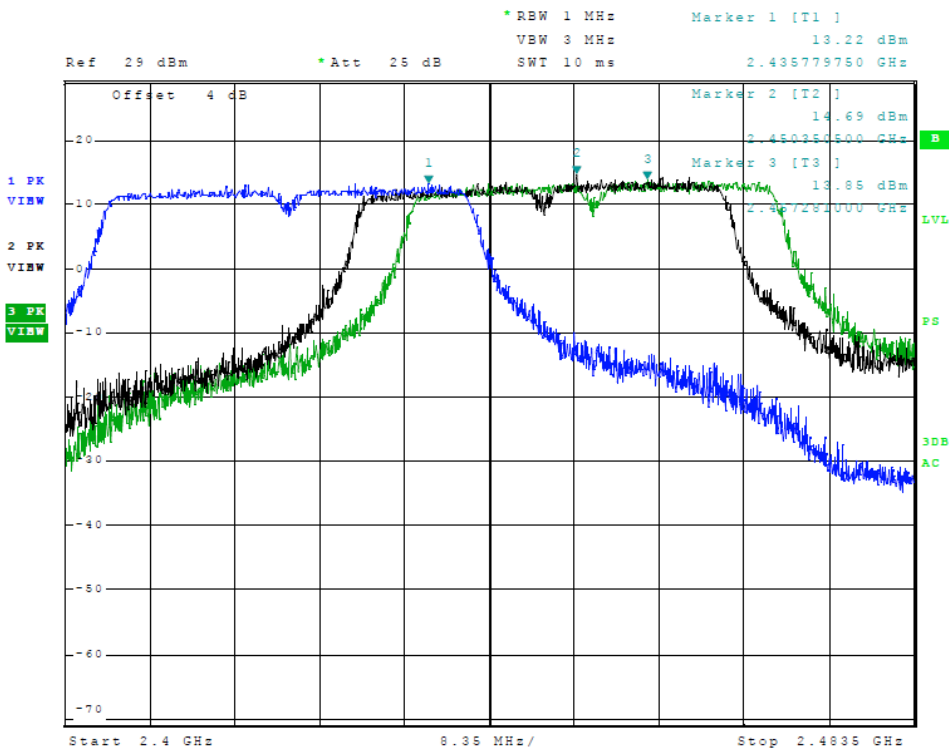

Figure 22 Plot of Transmitter Emissions (Across Operational Band, 802.11n (40), Chain 1)

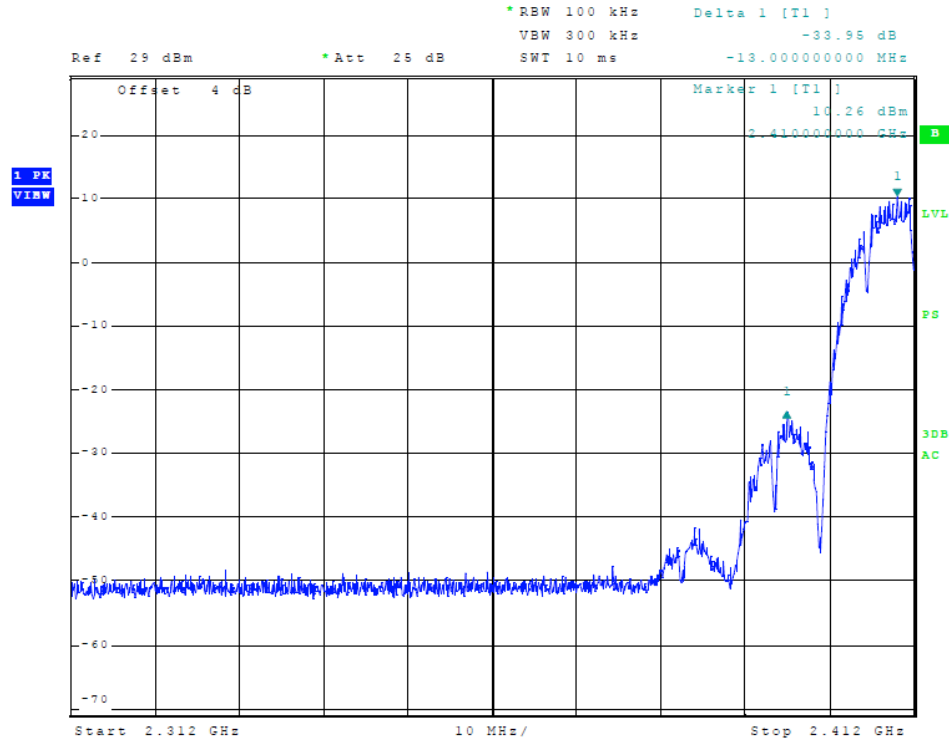

Figure 23 Plot of Transmitter Low Band Edge (802.11b, Chain 1)

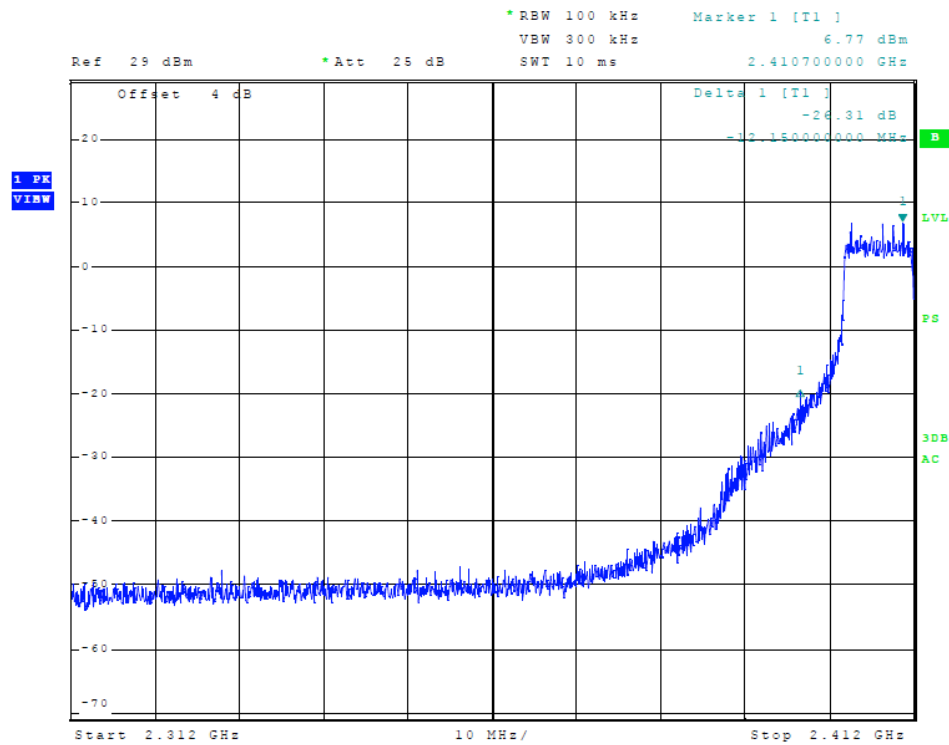

Figure 24 Plot of Transmitter Low Band Edge (802.11g, Chain 1)

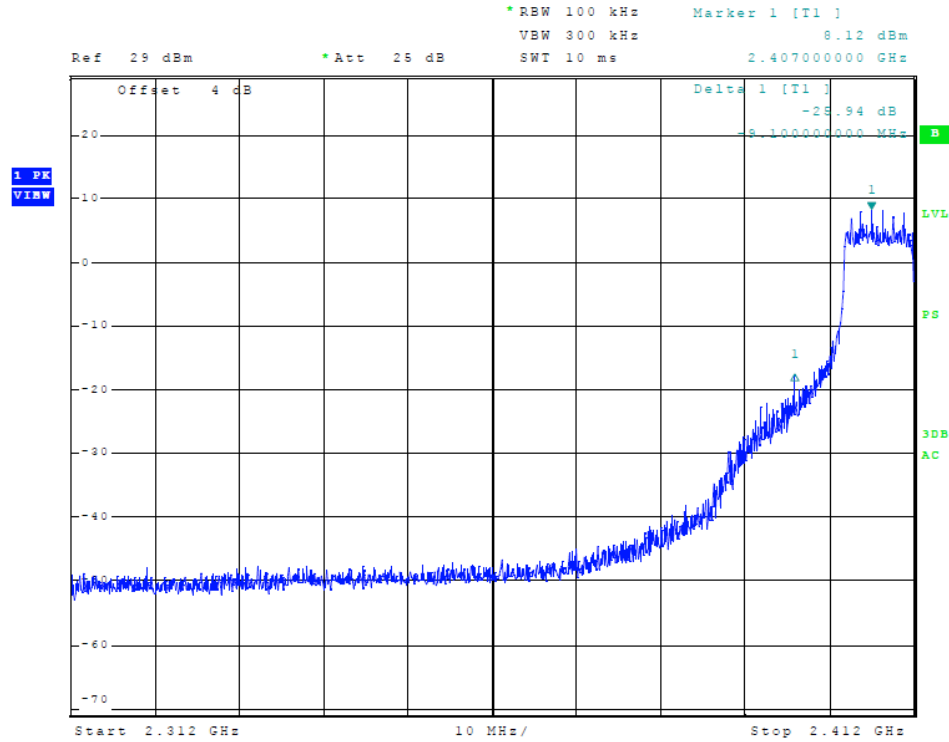

Figure 25 Plot of Transmitter Low Band Edge (802.11n (20), Chain 1)

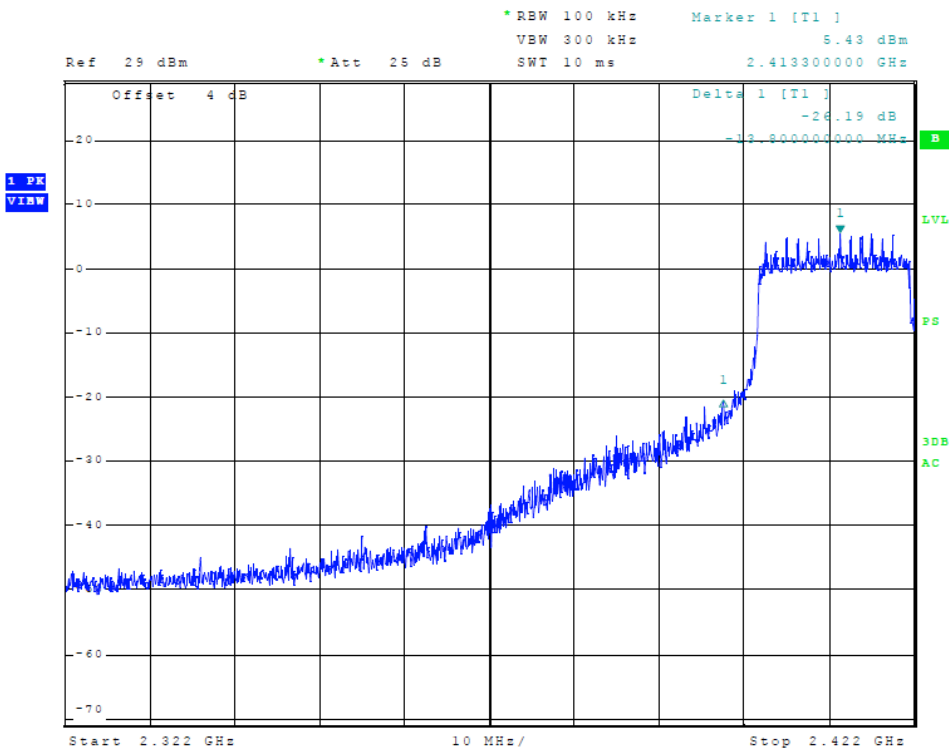

Figure 26 Plot of Transmitter Low Band Edge (802.11n (40), Chain 1)

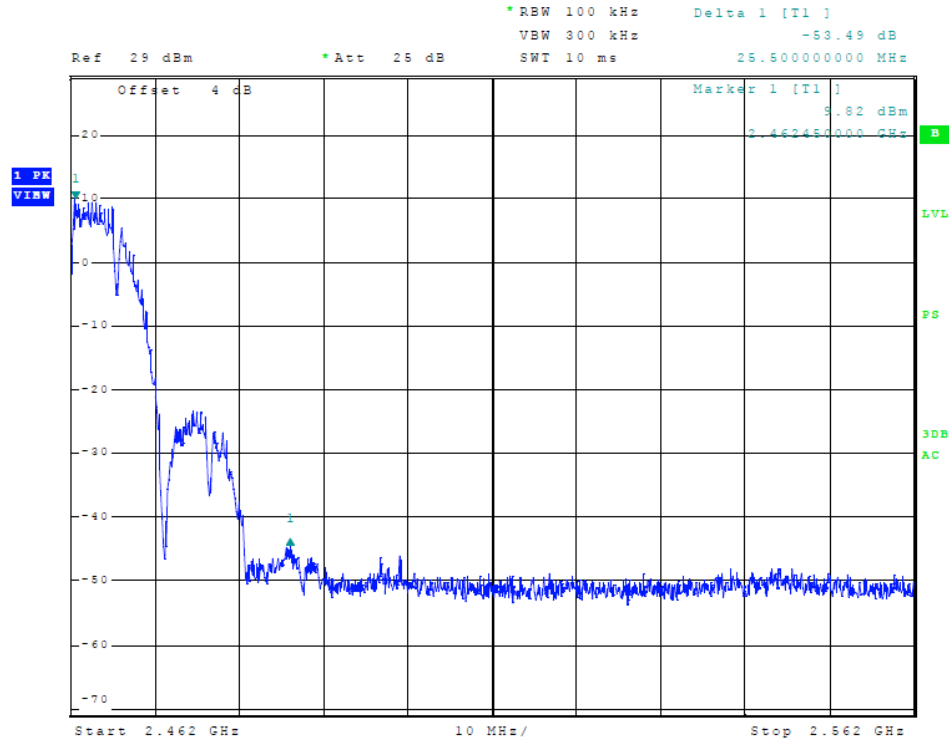

Figure 27 Plot of Transmitter High Band Edge (802.11b, Chain 1)

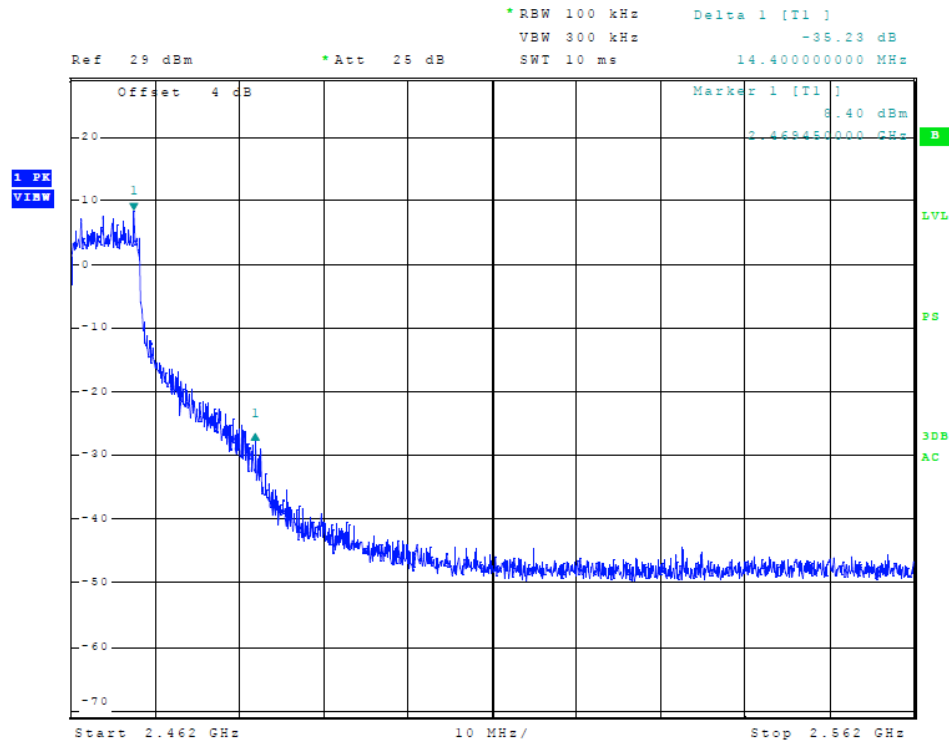

Figure 28 Plot of Transmitter High Band Edge (802.11g, Chain 1)

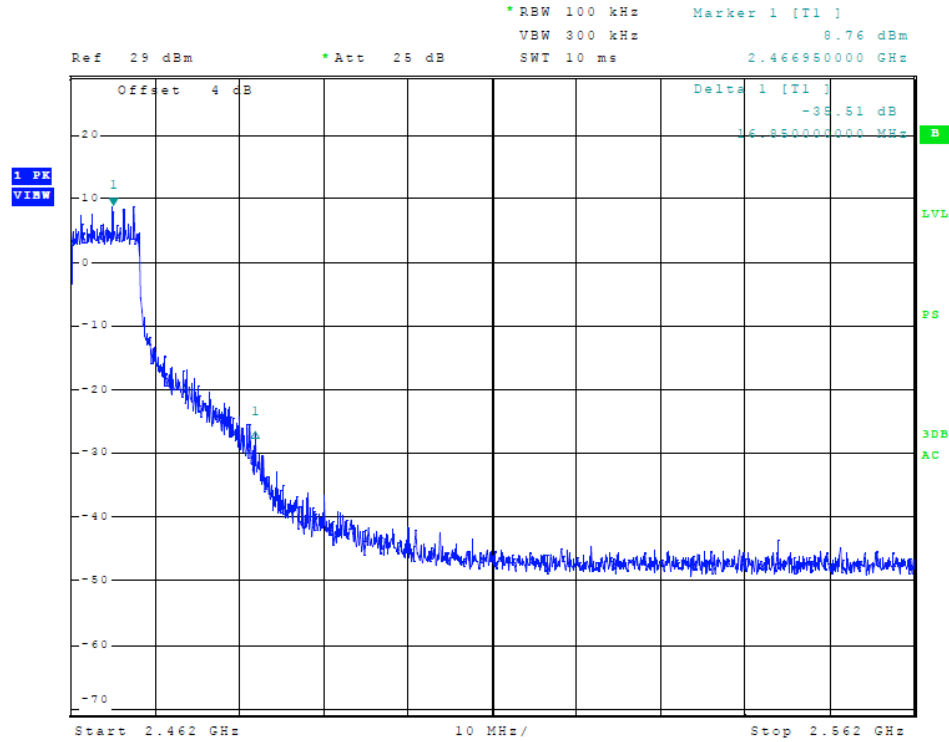

Figure 29 Plot of Transmitter High Band Edge (802.11n (20), Chain 1)

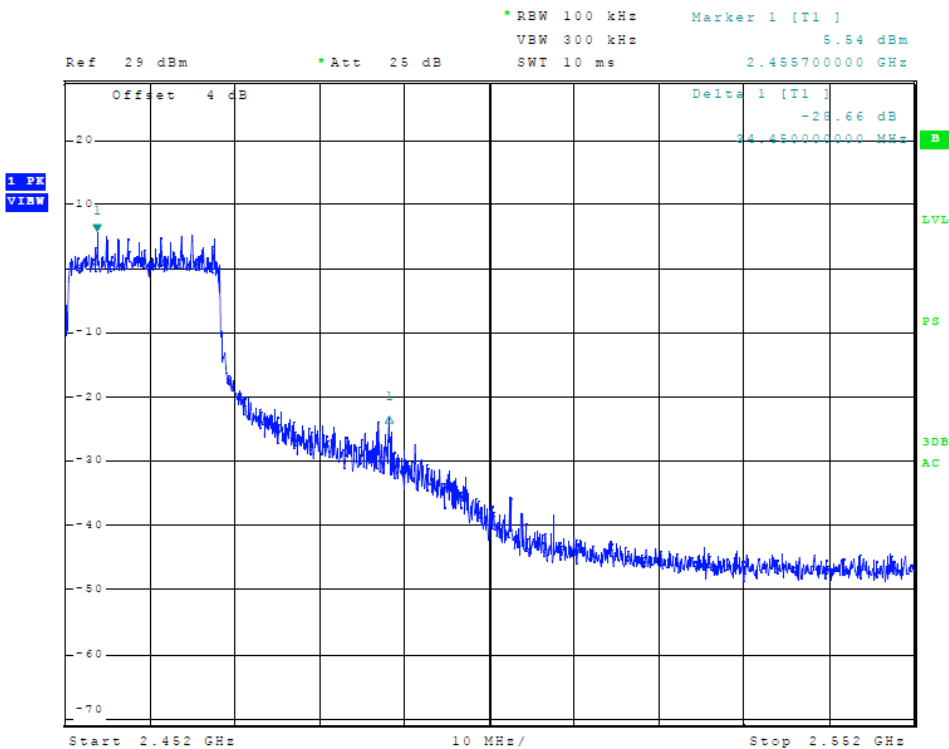

Figure 30 Plot of Transmitter High Band Edge (802.11n (40), Chain 1)

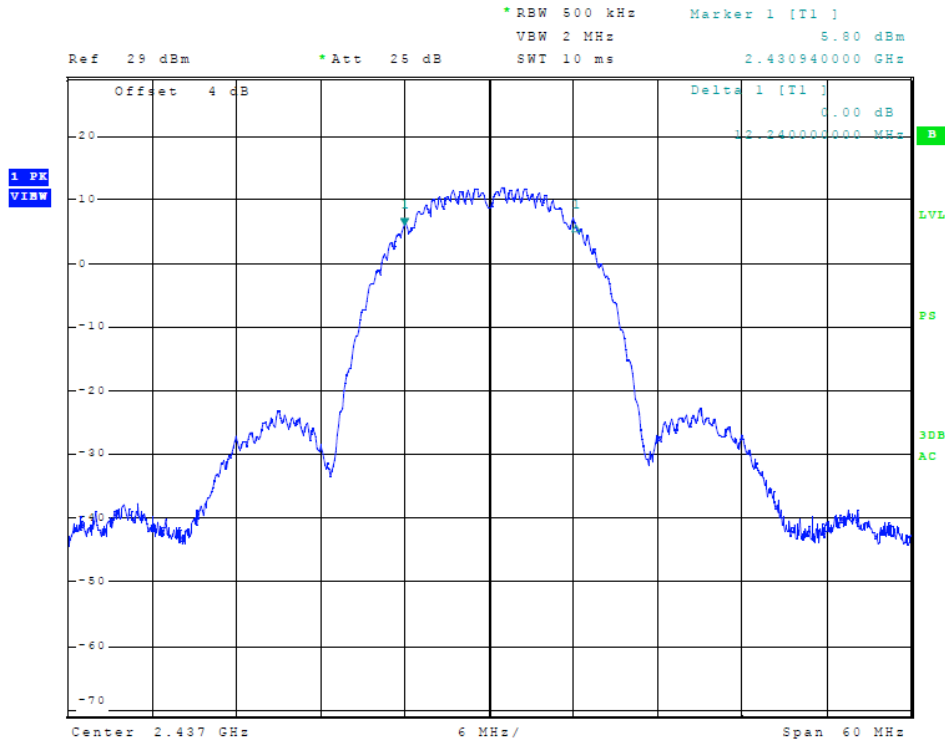

Figure 31 Plot of Transmitter 6-dB Occupied Band Width (802.11b, Chain 1)

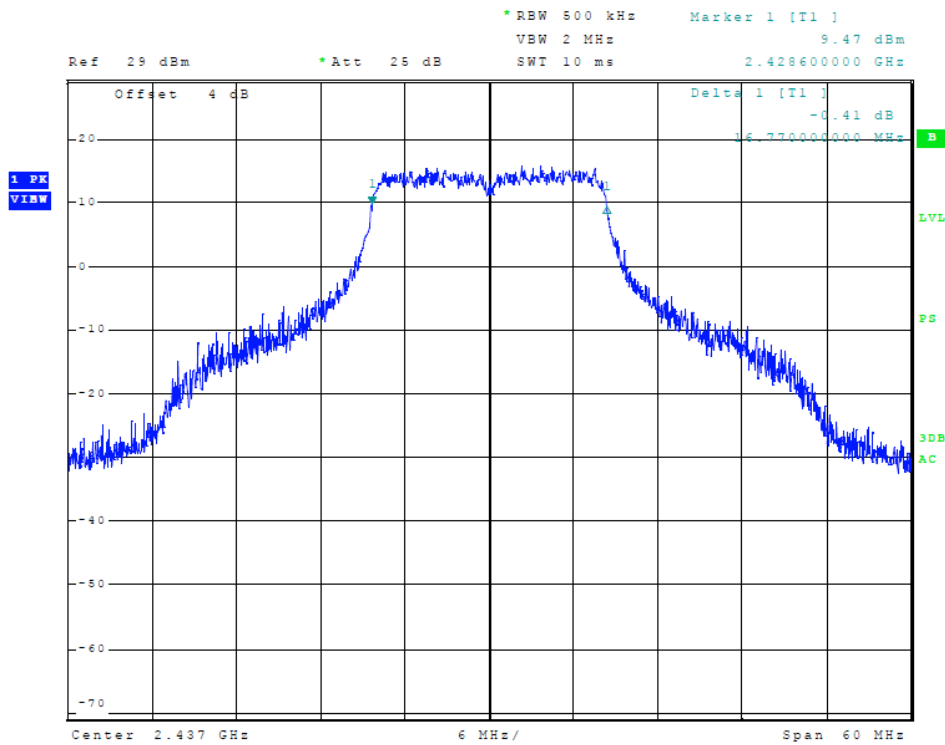

Figure 32 Plot of Transmitter 6-dB Occupied Band Width (802.11g, Chain 1)

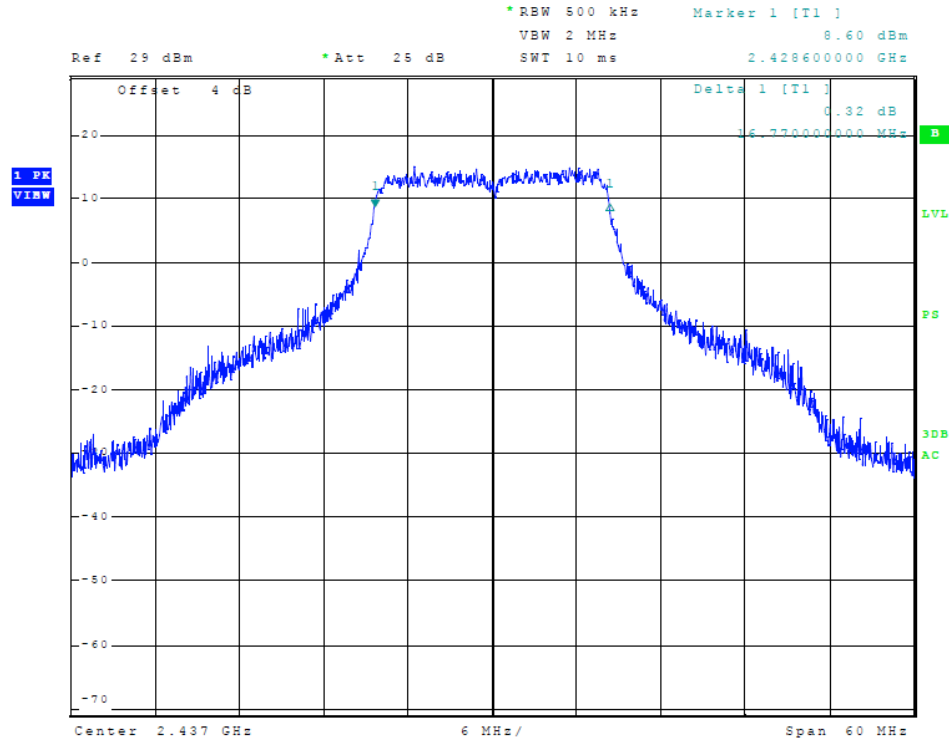

Figure 33 Plot of Transmitter 6-dB Occupied Band Width (802.11n (20), Chain 1)

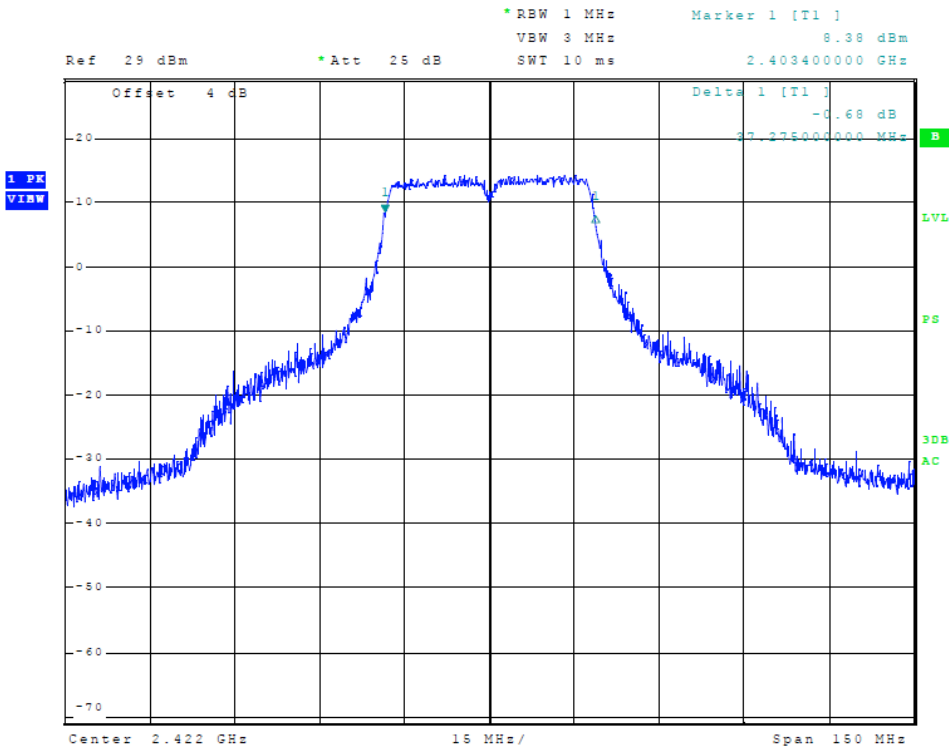

Figure 34 Plot of Transmitter 6-dB Occupied Band Width (802.11n (40), Chain 1)

Transmitter Emissions Data

Table 14 Transmitter Power and Emissions

Frequency MHz	Conducted Antenna Port Output Power (Watts) Total / Chain 0 / Chain 1	6-dB Occupied Bandwidth kHz	Power Spectral Density dBm Total / Chain 0 / Chain 1
20 MHz b-Mode			
2412.0	0.378 / 0.209 / 0.169	12240	0.4 / -1.5 / 4.1
2437.0	0.372 / 0.177 / 0.195	12240	0.3 / -1.4 / -4.6
2462.0	0.329 / 0.161 / 0.168	12120	-0.3 / -3.0 / -3.5
20 MHz g-Mode			
2412.0	0.349 / 0.174 / 0.174	16640	0.2 / -2.1 / -5.3
2437.0	0.315 / 0.151 / 0.163	16770	-0.2 / -2.2 / -4.3
2462.0	0.309 / 0.150 / 0.158	16920	-1.4 / -3.6 / -3.5
20 MHz n-Mode			
2412.0	0.336 / 0.166 / 0.170	16840	1.2 / -0.3 / -4.4
2437.0	0.298 / 0.146 / 0.152	16770	1.0 / -0.2 / -5.2
2462.0	0.300 / 0.139 / 0.160	16650	-2.0 / -5.1 / -4.9
40 MHz Mode			
2422.0	0.303 / 0.156 / 0.147	36675	-4.9 / -7.7 / -8.1
2447.0	0.288 / 0.152 / 0.136	36975	-0.8 / -1.6 / -8.1
2452.0	0.288 / 0.150 / 0.138	36750	-5.8 / -9.0 / -8.7

Table 15 Transmitter Radiated Emissions (Worst-case 20 MHz mode, WLO-2450-15)

Frequency in MHz	Horizontal Peak (dBµV/m)	Horizontal Average (dBµV/m)	Vertical Peak (dBµV/m)	Vertical Average (dBµV/m)	Limit @ 3m (dBµV/m)
2412.0	-	-	-	-	-
4824.0	44.1	31.0	52.4	43.5	54.0
7236.0	45.3	32.5	43.7	31.3	54.0
9648.0	46.0	33.3	46.0	33.0	54.0
12060.0	50.7	37.7	51.1	37.9	54.0
14472.0	52.1	39.1	51.6	39.0	54.0
16884.0	55.5	42.3	55.0	42.3	54.0
2437.0	-	-	-	-	-
4874.0	45.6	32.0	44.6	31.9	54.0
7311.0	45.9	32.9	46.0	33.0	54.0
9748.0	48.5	35.1	48.5	37.0	54.0
12185.0	50.3	37.5	50.5	37.6	54.0
14622.0	51.7	39.1	52.0	39.2	54.0
17059.0	56.7	43.8	56.5	43.9	54.0
2462.0	-	-	-	-	-
4924.0	43.1	30.4	44.1	31.1	54.0
7386.0	45.7	32.9	45.3	32.8	54.0
9848.0	46.0	33.2	46.0	33.1	54.0
12310.0	50.7	37.5	50.5	37.6	54.0
14772.0	53.3	40.3	53.1	40.2	54.0
17234.0	57.8	44.8	58.1	45.0	54.0

Other emissions present had amplitudes at least 20 dB below the limit. Peak and Quasi-Peak amplitude emissions are recorded above for frequency range of 30-1000 MHz. Peak and Average amplitude emissions are recorded above for frequency range above 1000 MHz.

Table 16 Transmitter Radiated Emissions (Worst-case 40 MHz mode, WLO-2450-15)

Frequency in MHz	Horizontal Peak (dB μ V/m)	Horizontal Average (dB μ V/m)	Vertical Peak (dB μ V/m)	Vertical Average (dB μ V/m)	Limit @ 3m (dB μ V/m)
2422.0	-	-	-	-	-
4844.0	43.7	30.8	43.2	30.8	54.0
7266.0	45.9	33.2	45.5	33.1	54.0
9688.0	46.1	33.5	46.6	33.5	54.0
12110.0	50.3	37.9	51.5	38.0	54.0
14532.0	53.0	39.4	52.4	39.6	54.0
16954.0	55.2	42.6	55.3	42.6	54.0
2447.0	-	-	-	-	-
4894.0	44.1	30.6	43.9	30.4	54.0
7341.0	44.5	31.1	45.5	32.4	54.0
9788.0	46.2	33.9	46.4	34.1	54.0
12235.0	50.6	37.5	50.3	37.6	54.0
14682.0	51.1	38.9	52.1	39.1	54.0
17129.0	57.3	44.4	57.0	44.5	54.0
2452.0	-	-	-	-	-
4904.0	43.5	30.7	44.1	30.6	54.0
7356.0	46.6	33.4	46.1	33.4	54.0
9808.0	46.9	33.8	47.0	33.8	54.0
12260.0	50.1	37.8	50.5	37.8	54.0
14712.0	52.1	39.4	52.3	39.2	54.0
17164.0	57.3	44.9	57.3	44.9	54.0

Other emissions present had amplitudes at least 20 dB below the limit. Peak and Quasi-Peak amplitude emissions are recorded above for frequency range of 30-1000 MHz. Peak and Average amplitude emissions are recorded above for frequency range above 1000 MHz.

Table 17 Transmitter Radiated Emissions (Worst-case 20 MHz mode, ODH 24-13)

Frequency in MHz	Horizontal Peak (dB μ V/m)	Horizontal Average (dB μ V/m)	Vertical Peak (dB μ V/m)	Vertical Average (dB μ V/m)	Limit @ 3m (dB μ V/m)
2412.0	-	-	-	-	-
4824.0	46.2	36.7	43.8	31.1	54.0
7236.0	45.6	32.8	45.4	32.9	54.0
9648.0	45.2	32.8	46.7	33.0	54.0
12060.0	50.8	37.8	50.9	37.7	54.0
14472.0	52.0	39.2	51.7	39.0	54.0
16884.0	55.2	42.2	55.2	42.3	54.0
2437.0	-	-	-	-	-
4874.0	44.2	31.0	44.3	31.6	54.0
7311.0	46.0	33.0	46.2	33.2	54.0
9748.0	47.3	34.7	47.6	34.8	54.0
12185.0	50.5	37.5	50.8	37.5	54.0
14622.0	52.3	39.3	52.3	39.4	54.0
17059.0	57.4	44.0	56.7	44.1	54.0
2462.0	-	-	-	-	-
4924.0	43.1	30.8	45.9	33.0	54.0
7386.0	46.1	33.2	46.0	33.1	54.0
9848.0	46.0	32.9	45.6	33.0	54.0
12310.0	50.6	37.9	50.1	37.6	54.0
14772.0	53.2	40.2	53.1	40.2	54.0
17234.0	57.3	44.4	57.2	44.4	54.0

Other emissions present had amplitudes at least 20 dB below the limit. Peak and Quasi-Peak amplitude emissions are recorded above for frequency range of 30-1000 MHz. Peak and Average amplitude emissions are recorded above for frequency range above 1000 MHz.

Table 18 Transmitter Radiated Emissions (Worst-case 40 MHz mode, ODH 24-13)

Frequency in MHz	Horizontal Peak (dBµV/m)	Horizontal Average (dBµV/m)	Vertical Peak (dBµV/m)	Vertical Average (dBµV/m)	Limit @ 3m (dBµV/m)
2422.0	-	-	-	-	-
4844.0	43.9	30.6	43.0	30.7	54.0
7266.0	45.8	32.8	46.1	32.9	54.0
9688.0	46.5	33.2	46.3	33.4	54.0
12110.0	50.3	37.9	51.2	38.3	54.0
14532.0	52.1	39.5	52.2	39.6	54.0
16954.0	55.3	42.6	55.4	42.7	54.0
2447.0	-	-	-	-	-
4894.0	43.6	30.7	43.4	30.6	54.0
7341.0	43.5	30.5	43.1	30.6	54.0
9788.0	47.1	33.9	47.5	33.8	54.0
12235.0	50.3	37.6	50.4	37.6	54.0
14682.0	51.4	39.0	51.9	38.9	54.0
17129.0	57.4	44.5	57.1	44.7	54.0
2452.0	-	-	-	-	-
4904.0	43.7	30.7	44.5	30.8	54.0
7356.0	45.8	33.5	46.3	33.5	54.0
9808.0	46.9	33.7	46.7	33.8	54.0
12260.0	50.6	38.0	50.5	37.7	54.0
14712.0	51.4	39.0	51.8	39.1	54.0
17164.0	57.5	44.7	57.3	44.7	54.0

Other emissions present had amplitudes at least 20 dB below the limit. Peak and Quasi-Peak amplitude emissions are recorded above for frequency range of 30-1000 MHz. Peak and Average amplitude emissions are recorded above for frequency range above 1000 MHz.

Table 19 Transmitter Radiated Emissions (Worst-case 20 MHz mode, WLP-2450-20)

Frequency in MHz	Horizontal Peak (dBµV/m)	Horizontal Average (dBµV/m)	Vertical Peak (dBµV/m)	Vertical Average (dBµV/m)	Limit @ 3m (dBµV/m)
2412.0	-	-	-	-	-
4824.0	43.4	30.6	43.6	30.9	54.0
7236.0	45.8	32.9	46.1	32.9	54.0
9648.0	45.8	33.0	46.6	33.0	54.0
12060.0	50.9	37.7	50.5	37.7	54.0
14472.0	52.3	39.1	52.7	39.1	54.0
16884.0	55.6	42.4	55.5	42.5	54.0
2437.0	-	-	-	-	-
4874.0	43.3	30.9	44.2	31.4	54.0
7311.0	45.9	32.8	45.6	32.9	54.0
9748.0	48.0	34.7	48.0	34.7	54.0
12185.0	50.3	37.7	50.7	37.7	54.0
14622.0	52.2	39.3	52.3	39.3	54.0
17059.0	57.5	44.4	57.1	44.4	54.0
2462.0	-	-	-	-	-
4924.0	43.5	30.7	43.3	30.6	54.0
7386.0	45.4	33.0	45.7	32.9	54.0
9848.0	45.6	33.0	45.5	33.1	54.0
12310.0	50.1	37.6	50.5	37.6	54.0
14772.0	52.7	40.1	52.6	40.1	54.0
17234.0	57.2	44.7	57.6	44.8	54.0

Other emissions present had amplitudes at least 20 dB below the limit. Peak and Quasi-Peak amplitude emissions are recorded above for frequency range of 30-1000 MHz. Peak and Average amplitude emissions are recorded above for frequency range above 1000 MHz.

Table 20 Transmitter Radiated Emissions (Worst-case 40 MHz mode, WLP-2450-20)

Frequency in MHz	Horizontal Peak (dB μ V/m)	Horizontal Average (dB μ V/m)	Vertical Peak (dB μ V/m)	Vertical Average (dB μ V/m)	Limit @ 3m (dB μ V/m)
2422.0	-	-	-	-	-
4844.0	43.6	30.8	43.4	30.7	54.0
7266.0	46.6	33.3	45.7	33.3	54.0
9688.0	46.1	33.4	46.0	33.4	54.0
12110.0	50.8	38.0	50.6	37.9	54.0
14532.0	52.2	39.5	52.4	39.5	54.0
16954.0	55.2	42.7	55.5	42.8	54.0
2447.0	-	-	-	-	-
4894.0	43.1	30.5	42.9	30.6	54.0
7341.0	46.1	33.2	45.3	33.0	54.0
9788.0	46.0	33.5	47.1	34.1	54.0
12235.0	50.7	37.1	50.2	37.6	54.0
14682.0	51.7	39.4	51.7	39.1	54.0
17129.0	57.1	43.9	57.5	44.6	54.0
2452.0	-	-	-	-	-
4904.0	43.3	30.7	43.8	30.8	54.0
7356.0	46.4	33.5	46.2	33.5	54.0
9808.0	46.6	33.7	46.5	33.7	54.0
12260.0	50.3	37.8	51.1	37.8	54.0
14712.0	52.3	39.5	53.0	39.6	54.0
17164.0	57.7	44.9	57.6	44.9	54.0

Other emissions present had amplitudes at least 20 dB below the limit. Peak and Quasi-Peak amplitude emissions are recorded above for frequency range of 30-1000 MHz. Peak and Average amplitude emissions are recorded above for frequency range above 1000 MHz.

Table 21 Transmitter Radiated Emissions (Worst-case 20 MHz mode, SA 24-90-17-WB)

Frequency in MHz	Horizontal Peak (dBµV/m)	Horizontal Average (dBµV/m)	Vertical Peak (dBµV/m)	Vertical Average (dBµV/m)	Limit @ 3m (dBµV/m)
2412.0	-	-	-	-	-
4824.0	43.4	30.9	43.9	31.3	54.0
7236.0	44.6	31.3	43.4	31.3	54.0
9648.0	46.2	33.1	46.5	33.1	54.0
12060.0	50.7	37.7	50.1	37.7	54.0
14472.0	51.8	39.0	51.8	39.0	54.0
16884.0	55.5	42.2	55.1	42.3	54.0
2437.0	-	-	-	-	-
4874.0	44.4	31.2	45.6	32.6	54.0
7311.0	44.5	31.6	44.5	31.7	54.0
9748.0	47.0	34.3	47.3	34.4	54.0
12185.0	50.4	37.6	50.2	37.7	54.0
14622.0	51.8	39.2	52.0	39.3	54.0
17059.0	57.6	44.2	57.3	44.2	54.0
2462.0	-	-	-	-	-
4924.0	43.3	30.8	44.5	32.2	54.0
7386.0	44.7	32.1	45.6	32.2	54.0
9848.0	46.3	32.9	46.3	33.0	54.0
12310.0	50.3	37.6	50.6	37.6	54.0
14772.0	53.0	40.1	53.1	40.2	54.0
17234.0	57.2	44.7	57.3	44.7	54.0

Other emissions present had amplitudes at least 20 dB below the limit. Peak and Quasi-Peak amplitude emissions are recorded above for frequency range of 30-1000 MHz. Peak and Average amplitude emissions are recorded above for frequency range above 1000 MHz.

Table 22 Transmitter Radiated Emissions (Worst-case 40 MHz mode, SA 24-90-17-WB)

Frequency in MHz	Horizontal Peak (dB μ V/m)	Horizontal Average (dB μ V/m)	Vertical Peak (dB μ V/m)	Vertical Average (dB μ V/m)	Limit @ 3m (dB μ V/m)
2422.0	-	-	-	-	-
4844.0	43.7	30.5	43.2	30.6	54.0
7266.0	45.8	33.3	46.1	33.3	54.0
9688.0	46.6	33.5	46.2	33.5	54.0
12110.0	50.2	37.8	50.4	37.8	54.0
14532.0	52.1	39.9	53.0	39.4	54.0
16954.0	56.2	42.6	54.9	42.5	54.0
2447.0	-	-	-	-	-
4894.0	43.3	30.3	43.1	30.5	54.0
7341.0	45.7	32.9	45.8	33.0	54.0
9788.0	47.0	34.2	47.1	34.2	54.0
12235.0	50.3	37.6	50.8	37.6	54.0
14682.0	51.1	38.9	52.0	38.9	54.0
17129.0	57.4	44.4	57.3	44.4	54.0
2452.0	-	-	-	-	-
4904.0	43.8	30.7	43.3	30.8	54.0
7356.0	44.1	31.0	43.7	31.1	54.0
9808.0	46.2	33.5	46.0	33.6	54.0
12260.0	50.1	37.6	51.1	37.6	54.0
14712.0	51.7	39.2	52.2	39.3	54.0
17164.0	57.6	44.7	57.6	44.9	54.0

Other emissions present had amplitudes at least 20 dB below the limit. Peak and Quasi-Peak amplitude emissions are recorded above for frequency range of 30-1000 MHz. Peak and Average amplitude emissions are recorded above for frequency range above 1000 MHz.

Table 23 Transmitter Radiated Emissions (Worst-case 20 MHz mode, DC 24-HD-PFIP)

Frequency in MHz	Horizontal Peak (dB μ V/m)	Horizontal Average (dB μ V/m)	Vertical Peak (dB μ V/m)	Vertical Average (dB μ V/m)	Limit @ 3m (dB μ V/m)
2412.0	-	-	-	-	-
4824.0	43.5	30.5	44.5	34.1	54.0
7236.0	45.7	32.7	45.4	32.8	54.0
9648.0	45.8	33.2	46.0	33.2	54.0
12060.0	50.2	37.7	50.1	37.7	54.0
14472.0	51.5	39.0	51.8	39.0	54.0
16884.0	54.9	42.2	54.9	42.3	54.0
2437.0	-	-	-	-	-
4874.0	44.0	30.9	43.9	30.8	54.0
7311.0	46.1	33.2	46.1	33.1	54.0
9748.0	47.2	34.7	47.7	34.8	54.0
12185.0	50.1	37.4	50.3	37.4	54.0
14622.0	51.9	39.0	51.5	39.1	54.0
17059.0	57.3	43.7	57.0	43.9	54.0
2462.0	-	-	-	-	-
4924.0	43.5	30.4	43.8	30.9	54.0
7386.0	46.0	33.2	46.0	33.3	54.0
9848.0	45.7	33.0	46.0	33.0	54.0
12310.0	50.1	37.5	50.0	37.5	54.0
14772.0	52.8	40.0	53.1	40.1	54.0
17234.0	57.1	44.5	57.4	44.5	54.0

Other emissions present had amplitudes at least 20 dB below the limit. Peak and Quasi-Peak amplitude emissions are recorded above for frequency range of 30-1000 MHz. Peak and Average amplitude emissions are recorded above for frequency range above 1000 MHz.

Table 24 Transmitter Radiated Emissions (Worst-case 40 MHz mode, DC 24-HD-PFIP)

Frequency in MHz	Horizontal Peak (dBµV/m)	Horizontal Average (dBµV/m)	Vertical Peak (dBµV/m)	Vertical Average (dBµV/m)	Limit @ 3m (dBµV/m)
2422.0	-	-	-	-	-
4844.0	43.7	30.7	44.0	30.7	54.0
7266.0	45.2	32.3	44.7	32.3	54.0
9688.0	46.0	33.2	46.4	33.2	54.0
12110.0	50.8	37.7	50.1	37.7	54.0
14532.0	52.2	39.4	52.8	39.4	54.0
16954.0	55.2	42.5	54.8	42.5	54.0
2447.0	-	-	-	-	-
4894.0	43.5	30.5	44.0	30.6	54.0
7341.0	46.3	32.2	44.9	32.2	54.0
9788.0	46.6	34.2	46.7	34.3	54.0
12235.0	50.0	37.5	50.1	37.5	54.0
14682.0	51.9	39.0	51.2	39.0	54.0
17129.0	58.0	44.5	56.8	44.5	54.0
2452.0	-	-	-	-	-
4904.0	43.5	30.7	43.7	30.8	54.0
7356.0	45.9	33.2	46.2	33.0	54.0
9808.0	46.3	33.6	46.4	33.7	54.0
12260.0	51.1	37.9	50.2	37.6	54.0
14712.0	52.9	39.1	51.8	39.2	54.0
17164.0	57.8	44.6	57.8	44.8	54.0

Other emissions present had amplitudes at least 20 dB below the limit. Peak and Quasi-Peak amplitude emissions are recorded above for frequency range of 30-1000 MHz. Peak and Average amplitude emissions are recorded above for frequency range above 1000 MHz.

Summary of Results for Transmitter Radiated Emissions of Intentional Radiator

The EUT demonstrated compliance with the radiated emissions requirements of 47CFR Part 15.247 and Industry Canada RSS-247. The highest conducted power was 0.378-Watts. The worst-case total peak power spectral density provided a minimum margin of -6.8 dB below the requirements. The minimum radiated harmonic emission provided -9.0 dB margin below requirements. There were no other significantly measurable emissions in the restricted bands other than those recorded in this report. Other emissions were present with amplitudes at least 20 dB below the requirements. There were no other deviations or exceptions to the requirements.

Statement of Modifications and Deviations

No modifications to the EUT were required for the unit to demonstrate compliance with the 47CFR Part 15C and Industry Canada RSS-247 emissions requirements. There were no deviations or modifications to the specifications.

Annex

- Annex A Measurement Uncertainty Calculations
- Annex B Rogers Labs Test Equipment List
- Annex C Rogers Qualifications
- Annex D FCC Site Registration Letter
- Annex E Industry Canada Site Registration Letter

Annex A Measurement Uncertainty Calculations

Measurement uncertainty calculations were made for the laboratory. Result of measurement uncertainty calculations are recorded below for AC line conducted and radiated emission measurements.

Measurement Uncertainty	$U_{(E)}$	$U_{(lab)}$
3 Meter Horizontal 30-200 MHz Measurements	2.08	4.16
3 Meter Vertical 30-200 MHz Measurements	2.16	4.33
3 Meter Vertical Measurements 200-1000 MHz	2.99	5.97
10 Meter Horizontal Measurements 30-200 MHz	2.07	4.15
10 Meter Vertical Measurements 30-200 MHz	2.06	4.13
10 Meter Horizontal Measurements 200-1000 MHz	2.32	4.64
10 Meter Vertical Measurements 200-1000 MHz	2.33	4.66
3 Meter Measurements 1-6 GHz	2.57	5.14
3 Meter Measurements 6-18 GHz	2.58	5.16
AC Line Conducted	1.72	3.43

Annex B Rogers Labs Test Equipment List

List of Test Equipment	Calibration	Date	Due
Spectrum Analyzer: Rohde & Schwarz ESU40		5/16	5/17
Spectrum Analyzer: HP 8562A, HP Adapters: 11518, 11519, and 11520		5/16	5/17
Mixers: 11517A, 11970A, 11970K, 11970U, 11970V, 11970W			
Spectrum Analyzer: HP 8591EM		5/16	5/17
Antenna: EMCO Biconilog Model: 3143		5/16	5/17
Antenna: Sunol Biconilog Model: JB6		10/15	10/16
Antenna: EMCO Log Periodic Model: 3147		10/15	10/16
Antenna: Com Power Model: AH-118		10/15	10/16
Antenna: Com Power Model: AH-840		5/16	5/18
Antenna: Antenna Research Biconical Model: BCD 235		10/15	10/16
Antenna: EMCO 6509		10/15	10/16
LISN: Compliance Design Model: FCC-LISN-2.Mod.cd, 50 µHy/50 ohm/0.1 µf		10/15	10/16
R.F. Preamp CPPA-102		10/15	10/16
Attenuator: HP Model: HP11509A		10/15	10/16
Attenuator: Mini Circuits Model: CAT-3		10/15	10/16
Attenuator: Mini Circuits Model: CAT-3		10/15	10/16
Cable: Belden RG-58 (L1)		10/15	10/16
Cable: Belden RG-58 (L2)		10/15	10/16
Cable: Belden 8268 (L3)		10/15	10/16
Cable: Time Microwave: 4M-750HF290-750		10/15	10/16
Cable: Time Microwave: 10M-750HF290-750		10/15	10/16
Frequency Counter: Leader LDC825		2/16	2/17
Oscilloscope Scope: Tektronix 2230		2/16	2/17
Wattmeter: Bird 43 with Load Bird 8085		2/16	2/17
Power Supplies: Sorensen SRL 20-25, SRL 40-25, DCR 150, DCR 140		2/16	2/17
R.F. Generators: HP 606A, HP 8614A, HP 8640B		2/16	2/17
R.F. Power Amp 65W Model: 470-A-1010		2/16	2/17
R.F. Power Amp 50W M185- 10-501		2/16	2/17
R.F. Power Amp A.R. Model: 10W 1010M7		2/16	2/17
R.F. Power Amp EIN Model: A301		2/16	2/17
LISN: Compliance Eng. Model 240/20		2/16	2/17
LISN: Fischer Custom Communications Model: FCC-LISN-50-16-2-08		2/16	2/17
Antenna: EMCO Dipole Set 3121C		2/16	2/17
Antenna: C.D. B-101		2/16	2/17
Antenna: Solar 9229-1 & 9230-1		2/16	2/17
Audio Oscillator: H.P. 201CD		2/16	2/17
ELGAR Model: 1751		2/16	2/17
ELGAR Model: TG 704A-3D		2/16	2/17
ESD Test Set 2010i		2/16	2/17
Fast Transient Burst Generator Model: EFT/B-101		2/16	2/17
Field Intensity Meter: EFM-018		2/16	2/17
KEYTEK Ecat Surge Generator		2/16	2/17
Shielded Room 5 M x 3 M x 3.0 M			

Annex C Rogers Qualifications

Scot D. Rogers, Engineer

Rogers Labs, Inc.

Mr. Rogers has approximately 17 years' experience in the field of electronics. Engineering experience includes six years in the automated controls industry and remaining years working with the design, development and testing of radio communications and electronic equipment.

Positions Held

Systems Engineer: A/C Controls Mfg. Co., Inc. 6 Years

Electrical Engineer: Rogers Consulting Labs, Inc. 5 Years

Electrical Engineer: Rogers Labs, Inc. Current

Educational Background

- 1) Bachelor of Science Degree in Electrical Engineering from Kansas State University.
- 2) Bachelor of Science Degree in Business Administration Kansas State University.
- 3) Several Specialized Training courses and seminars pertaining to Microprocessors and Software programming.

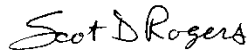

Scot D. Rogers

Annex D FCC Site Registration Letter

FEDERAL COMMUNICATIONS COMMISSION

**Laboratory Division
7435 Oakland Mills Road
Columbia, MD 21046**

April 16, 2015

Registration Number: 90910

Rogers Labs, Inc.
4405 West 259th Terrace
Louisburg, KS 66053

Attention: Scot Rogers,

Re: Measurement facility located at Louisburg
3 & 10 meter site
Date of Renewal: April 16, 2015

Dear Sir or Madam:

Your request for renewal of the registration of the subject measurement facility has been received. The information submitted has been placed in your file and the registration has been renewed. The name of your organization will remain on the list of facilities whose measurement data will be accepted in conjunction with applications for Certification under Parts 15 or 18 of the Commission's Rules. Please note that the file must be updated for any changes made to the facility and the registration must be renewed at least every three years.

Measurement facilities that have indicated that they are available to the public to perform measurement services on a fee basis may be found on the FCC website www.fcc.gov under E-Filing, OET Equipment Authorization Electronic Filing, Test Firms.

Sincerely,

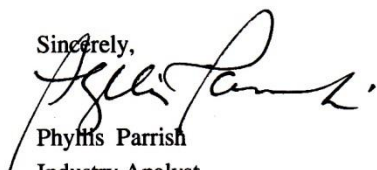
Phyllis Parrish
Industry Analyst

Rogers Labs, Inc.
4405 W. 259th Terrace
Louisburg, KS 66053

Phone/Fax: (913) 837-3214

Revision 1

Mikrotikls SIA
Model: R52HnD
Test #: 160720

Test to: 47CFR 15.247, RSS-247

File: Mikrotikls R52HnD DTS TstRpt 160720

S/N: 26114

FCC: TV7R52HND

IC: 7442A-R52HND

Date: August 24, 2016

Page 67 of 68

Annex E Industry Canada Site Registration Letter

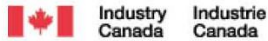

June 08, 2015

OUR FILE: 46405-3041
Authorization No: 010277847-001

Rogers Labs Inc.
4405 West 259th Terrace
Louisburg, KS
USA
66053

Attention: Mr. Scot D. Rogers

Dear Sir:

The Bureau has received your application for the renewal of 3m OATS. Be advised that the information received was satisfactory to Industry Canada. The following number(s) is now associated to the site(s) for which registration / renewal was sought (**Site# 3041A-1**). Please reference the appropriate site number in the body of test reports containing measurements performed on the site. In addition, please keep for your records the following information;

- The company address code associated to the site(s) located at the above address is: **3041A**

Furthermore, to obtain or renew a unique site number, the applicant shall demonstrate that the site has been accredited to ANSI C63.4-2009 or later. A scope of accreditation indicating the accreditation by a recognized accreditation body to ANSI C63.4-2009 or later shall be accepted. Please indicate in a letter the previous assigned site number if applicable and the type of site (example: 3 metre OATS or 3 metre chamber). If the test facility is not accredited to ANSI C63.4-2009 or later, the test facility shall submit test data demonstrating full compliance with the ANSI standard. The Bureau will evaluate the filing to determine if recognition shall be granted.

The frequency for re-validation of the test site and the information that is required to be filed or retained by the testing party shall comply with the requirements established by the accrediting organization. However, in all cases, test site re-validation shall occur on an interval not to exceed **three years**. There is no fee or form associated with an OATS filing. OATS submissions are encouraged to be submitted electronically to the Bureau using the following URL; http://strategis.ic.gc.ca/epic/internet/inceb-bhst.nsf/en/h_tt00052e.html.

If you have any questions, you may contact the Bureau by e-mail at certification.bureau@ic.gc.ca Please reference our file and submission number above for all correspondence.

Yours sincerely,

A handwritten signature in black ink, appearing to read "Bill Payn".

Bill Payn
For: Wireless Laboratory Manager
Certification and Engineering Bureau
3701 Carling Ave., Building 94
P.O. Box 11490, Station AH@
Ottawa, Ontario K2H 8S2
Email: certification.bureau@ic.gc.ca

Rogers Labs, Inc.
4405 W. 259th Terrace
Louisburg, KS 66053
Phone/Fax: (913) 837-3214
Revision 1

Mikrotikls SIA
Model: R52HnD
Test #: 160720
Test to: 47CFR 15.247, RSS-247
File: Mikrotikls R52HnD DTS TstRpt 160720

S/N: 26114
FCC: TV7R52HND
IC: 7442A-R52HND
Date: August 24, 2016
Page 68 of 68