

Submittal Application Report

For
Grant of Certification

Model: R11e-5HacD
5180-5240, and 5745-5825 MHz
Unlicensed National Information Infrastructure (U-NII) and
License-Exempt Local Area Network (LE-LAN) Devices
Transmitter Module
U-NII-1, U-NII-3 Operation
FCC ID: TV7R11E5HAM
IC: 7442A-R11E5HAM

FOR

Mikrotikls SIA

Brivibas gatve 214i
Riga Latvia LV-1039

Test Report Number: 181029

FCC Designation: US5305
IC Test Site Registration: 3041A-1

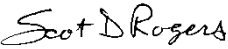
Authorized Signatory: 
Scot D. Rogers

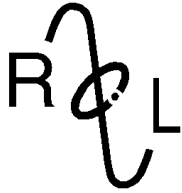

ROGERS LABS, INC.

4405 West 259th Terrace
Louisburg, KS 66053
Phone / Fax (913) 837-3214

Engineering Test Report for Grant of Certification Application

FOR

Unlicensed National Information Infrastructure (U-NII) and
License-Exempt Local Area Network (LE-LAN) Devices
47CFR, Part 15E 15.407 (New Rules)
Industry Canada RSS-247 Issue 2

For

Mikrotikls SIA

Brivibas gatve 214i
Riga Latvia LV-1039

License-Exempt U-NII, Local Area Network equipment
U-NII-1 and U-NII-3 operation

Model: R11e-5HacD
Transmitter Module

Frequency Range 5180-5240 and 5745-5825 MHz
FCC ID: TV7R11E5HAM
IC: 7442A-R11E5HAM

Test Date: October 29, 2018

Certifying Engineer: *Scot D. Rogers*

Scot D. Rogers
Rogers Labs, Inc.
4405 West 259th Terrace
Louisburg, KS 66053
Telephone/Facsimile: (913) 837-3214

This report shall not be reproduced except in full, without the written approval of the laboratory.
This report must not be used by the client to claim product certification, approval, or
endorsement by NVLAP, NIST, or any agency of the Federal Government.

Rogers Labs, Inc.	Mikrotikls SIA	S/N: 8EDC0800A953/814/r2
4405 W. 259th Terrace	Model: R11e-5HacD	FCC ID: TV7R11E5HAM
Louisburg, KS 66053	Test #: 181029	IC: 7442A- R11E5HAM
Phone/Fax: (913) 837-3214	Test to: 47CFR, 15.407, RSS-247	Date: January 31, 2019
Revision 2	File: Mikrotikls R11e5HacD TstRpt 181029 r2	Page 2 of 92

Table of Contents

TABLE OF CONTENTS.....	3
REVISIONS.....	8
FOREWORD.....	9
OPINION / INTERPRETATION OF RESULTS	9
EQUIPMENT TESTED.....	10
EQUIPMENT FUNCTION AND CONFIGURATION.....	11
Equipment Configuration.....	12
APPLICANT COMPANY INFORMATION	13
EQUIPMENT INFORMATION.....	13
Product Details	14
Accessories	14
Table for Filed Antennas	14
Antenna and Bandwidth.....	14
APPLICATION FOR CERTIFICATION.....	15
APPLICABLE STANDARDS & TEST PROCEDURES	16
EQUIPMENT TESTING PROCEDURES	16
AC Line Conducted Emission Test Procedure	16
Radiated Emission Test Procedure.....	17
Antenna Port Conducted Emission Test Procedure.....	17
Diagram 1 Test arrangement for Conducted emissions	18
Diagram 2 Test arrangement for radiated emissions of tabletop equipment.....	19
Diagram 3 Test arrangement for radiated emissions tested on Open Area Test Site (OATS).....	20
Diagram 4 Test arrangement for Antenna Port Conducted emissions	20

LIST OF TEST EQUIPMENT 21

TEST SITE LOCATIONS 22

UNITS OF MEASUREMENTS 22

ENVIRONMENTAL CONDITIONS..... 22

INTENTIONAL RADIATORS..... 22

Antenna Requirements22

Restricted Bands of Operation.....23

 Table 1 Radiated Emissions in Restricted Bands Data (802.11a) 9dBi Omni23

 Table 2 Radiated Emissions in Restricted Bands Data (802.11n) 9dBi Omni24

 Table 3 Radiated Emissions in Restricted Bands Data (802.11n40) 9dBi Omni25

 Table 4 Radiated Emissions in Restricted Bands Data (802.11ac) 9dBi Omni26

 Table 5 Radiated Emissions in Restricted Bands Data (802.11a) 24dBi Panel27

 Table 6 Radiated Emissions in Restricted Bands Data (802.11n) 24dBi Panel28

 Table 7 Radiated Emissions in Restricted Bands Data (802.11n40) 24dBi Panel29

 Table 8 Radiated Emissions in Restricted Bands Data (802.11ac) 24dBi Panel30

Summary of Results for Radiated Emissions in Restricted Bands30

AC Line Conducted Emissions Procedure31

 Figure 1 AC Line Conducted Emissions Line 132

 Figure 2 AC Line Conducted Emissions Line 232

 Table 9 AC Line Conducted Emissions Data (Line L1).....33

 Table 10 AC Line Conducted Emissions Data (Line L2).....33

Summary of Results for AC Line Conducted Emissions33

General Radiated Emissions Procedure.....34

 Table 11 General Radiated Emissions from EUT Data35

Summary of Results for General Radiated Emissions35

Operation in the 5150-5250 and 5725-5850 MHz Frequency U-NII-1 and U-NII-3 Bands36

Figure 3 Plot of Transmitter Emissions (Across 5150-5250 MHz Band, Chain 0, 802.11a).....38

Figure 4 Plot of Transmitter Emissions (Across 5150-5250 MHz Band, Chain 1, 802.11a).....38

Figure 5 Plot of Transmitter Emissions (Across 5150-5250 MHz Band, Chain 0, 802.11n40)39

Figure 6 Plot of Transmitter Emissions (Across 5150-5250 MHz Band, Chain 1, 802.11n40)39

Figure 7 Plot of Transmitter Emissions (Across 5150-5250 MHz Band, Chain 0, 802.11ac).....40

Figure 8 Plot of Transmitter Emissions (Across 5150-5250 MHz Band, Chain 1, 802.11ac).....40

Figure 9 Plot of Transmitter Low Band Edge (5150-5250 MHz Band, Chain 0, 802.11a)41

Figure 10 Plot of Transmitter Low Band Edge (5150-5250 MHz Band, Chain 1, 802.11a)41

Figure 11 Plot of Transmitter Low Band Edge (5150-5250 MHz Band, Chain 0, 802.11n40).....42

Figure 12 Plot of Transmitter Low Band Edge (5150-5250 MHz Band, Chain 1, 802.11n40).....42

Figure 13 Plot of Transmitter Low Band Edge (5150-5250 MHz Band, Chain 0, 802.11ac)43

Figure 14 Plot of Transmitter Low Band Edge (5150-5250 MHz Band, Chain 1, 802.11ac)43

Figure 15 Plot of Transmitter High Band Edge (5150-5250 MHz Band, Chain 0, 802.11a).....44

Figure 16 Plot of Transmitter High Band Edge (5150-5250 MHz Band, Chain 1, 802.11a).....44

Figure 17 Plot of Transmitter High Band Edge (5150-5250 MHz Band, Chain 0, 802.11n40)45

Figure 18 Plot of Transmitter High Band Edge (5150-5250 MHz Band, Chain 1, 802.11n40)45

Figure 19 Plot of Transmitter High Band Edge (5150-5250 MHz Band, Chain 0, 802.11ac).....46

Figure 20 Plot of Transmitter High Band Edge (5150-5250 MHz Band, Chain 1, 802.11ac).....46

Figure 21 Plot of Transmitter Emissions (5150-5250 MHz Band, 802.11a, Chain 0, 99% OBW)47

Figure 22 Plot of Transmitter Emissions (5150-5250 MHz Band, 802.11a, Chain 1, 99% OBW)47

Figure 23 Plot of Transmitter Emissions (5150-5250 MHz Band, 802.11a, Chain 0, 26 dB OBW).....48

Figure 24 Plot of Transmitter Emissions (5150-5250 MHz Band, 802.11a, Chain 1, 26 dB OBW).....48

Figure 25 Plot of Transmitter Emissions (5150-5250 MHz Band, 802.11n40, Chain 0, 99% OBW).....49

Figure 26 Plot of Transmitter Emissions (5150-5250 MHz Band, 802.11n40, Chain 1, 99% OBW).....49

Figure 27 Plot of Transmitter Emissions (5150-5250 MHz Band, 802.11n40, Chain 0, 26 dB OBW).....50

Figure 28 Plot of Transmitter Emissions (5150-5250 MHz Band, 802.11n40, Chain 1, 26 dB OBW).....50

Figure 29 Plot of Transmitter Emissions (5150-5250 MHz Band, 802.11ac, Chain 0, 99% OBW)51

Figure 30 Plot of Transmitter Emissions (5150-5250 MHz Band, 802.11ac, Chain 1, 99% OBW)51

Figure 31 Plot of Transmitter Emissions (5150-5250 MHz Band, 802.11ac, Chain 0, 26 dB OBW)52

Figure 32 Plot of Transmitter Emissions (5150-5250 MHz Band, 802.11ac, Chain 1, 26 dB OBW)52

Figure 33 Plot of Transmitter Emissions (Across 5725-5850 MHz Band, Chain 0, 802.11a).....53

Figure 34 Plot of Transmitter Emissions (Across 5725-5850 MHz Band, Chain 1, 802.11a).....53

Figure 35 Plot of Transmitter Emissions (Across 5725-5850 MHz Band, Chain 0, 802.11n40)54

Figure 36 Plot of Transmitter Emissions (Across 5725-5850 MHz Band, Chain 1, 802.11n40)54

Figure 37 Plot of Transmitter Emissions (Across 5725-5850 MHz Band, Chain 0, 802.11ac).....55

Figure 38 Plot of Transmitter Emissions (Across 5725-5850 MHz Band, Chain 1, 802.11ac).....55

Figure 39 Plot of Transmitter Low Band Edge (5725-5850 MHz Band, Chain 0, 802.11a)56

Figure 40 Plot of Transmitter Low Band Edge (5725-5850 MHz Band, Chain 1, 802.11a)56

Figure 41 Plot of Transmitter Low Band Edge (5725-5850 MHz Band, Chain 0, 802.11n40)57

Figure 42 Plot of Transmitter Low Band Edge (5725-5850 MHz Band, Chain 1, 802.11n40)57

Figure 43 Plot of Transmitter Low Band Edge (5725-5850 MHz Band, Chain 0, 802.11ac)58

Figure 44 Plot of Transmitter Low Band Edge (5725-5850 MHz Band, Chain 1, 802.11ac)58

Figure 45 Plot of Transmitter High Band Edge (5725-5850 MHz Band, Chain 0, 802.11a).....59

Figure 46 Plot of Transmitter High Band Edge (5725-5850 MHz Band, Chain 1, 802.11a).....59

Figure 47 Plot of Transmitter High Band Edge (5725-5850 MHz Band, Chain 0, 802.11n40)60

Figure 48 Plot of Transmitter High Band Edge (5725-5850 MHz Band, Chain 1, 802.11n40)60

Figure 49 Plot of Transmitter High Band Edge (5725-5850 MHz Band, Chain 0, 802.11ac).....61

Figure 50 Plot of Transmitter High Band Edge (5725-5850 MHz Band, Chain 1, 802.11ac).....61

Figure 51 Plot of Transmitter Emissions (5725-5850 MHz Band, 802.11a, Chain 0, 99% OBW)62

Figure 52 Plot of Transmitter Emissions (5725-5850 MHz Band, 802.11a, Chain 1, 99% OBW)62

Figure 53 Plot of Transmitter Emissions (5725-5850 MHz Band, 802.11a, Chain 0, 6-dB OBW)63

Figure 54 Plot of Transmitter Emissions (5725-5850 MHz Band, 802.11a, Chain 1, 6-dB OBW)63

Figure 55 Plot of Transmitter Emissions (5725-5850 MHz Band, 802.11n40, Chain 0, 99% OBW).....64

Figure 56 Plot of Transmitter Emissions (5725-5850 MHz Band, 802.11n40, Chain 1, 99% OBW).....64

Figure 57 Plot of Transmitter Emissions (5725-5850 MHz Band, 802.11n40, Chain 0, 6-dB OBW)65

Figure 58 Plot of Transmitter Emissions (5725-5850 MHz Band, 802.11n40, Chain 1, 6-dB OBW)65

Figure 59 Plot of Transmitter Emissions (5725-5850 MHz Band, 802.11ac, Chain 0, 99% OBW)66

Figure 60 Plot of Transmitter Emissions (5725-5850 MHz Band, 802.11ac, Chain 1, 99% OBW)66

Figure 61 Plot of Transmitter Emissions (5725-5850 MHz Band, 802.11ac, Chain 0, 6-dB OBW).....67

Figure 62 Plot of Transmitter Emissions (5725-5850 MHz Band, 802.11ac, Chain 1, 6-dB OBW).....67

Transmitter Emissions Data.....68

Table 12 Transmitter Radiated Emission (802.11a, 5150-5250 MHz Band) 9dBi Omni68

Table 13 Transmitter Radiated Emission (802.11a, 5725-5850 MHz Band) 9dBi Omni69

Table 14 Transmitter Radiated Emission (802.11n, 5150-5250 MHz Band) 9dBi Omni.....70

Table 15 Transmitter Radiated Emission (802.11n, 5725-5850 MHz Band) 9dBi Omni.....71

Table 16 Transmitter Radiated Emission (802.11n, 5150-5250 MHz Band) 9dBi Omni.....72

Table 17 Transmitter Radiated Emission (802.11n, 5725-5850 MHz Band) 9dBi Omni.....73

Table 18 Transmitter Radiated Emission (802.11ac, 5150-5250 MHz Band) 9dBi Omni74

Table 19 Transmitter Radiated Emission (802.11ac, 5725-5850 MHz Band) 9dBi Omni75

Table 20 Transmitter Radiated Emission (802.11a, 5150-5250 MHz Band) 24dBi Panel76

Table 21 Transmitter Radiated Emission (802.11a, 5725-5850 MHz Band) 24dBi Panel77

Table 22 Transmitter Radiated Emission (802.11n, 5150-5250 MHz Band) 24dBi Panel.....78

Table 23 Transmitter Radiated Emission (802.11n, 5725-5850 MHz Band) 24dBi Panel.....79

Table 24 Transmitter Radiated Emission (802.11n, 5150-5250 MHz Band) 24dBi Panel.....80

Table 25 Transmitter Radiated Emission (802.11n, 5725-5850 MHz Band) 24dBi Panel..... 81

Table 26 Transmitter Radiated Emission (802.11ac, 5150-5250 MHz Band) 24dBi Panel 82

Table 27 Transmitter Radiated Emission (802.11ac, 5725-5850 MHz Band) 24dBi Panel 83

Table 28 Transmitter Antenna Port Conducted Power and Emissions (Chain 0) 84

Table 29 Transmitter Antenna Port Conducted Power and Emissions (Chain 1) 85

Table 30 Transmitter Antenna Port Conducted Power and Emissions (Total All Chains) 86

Summary of Results for Transmitter Radiated Emissions of Intentional Radiator 87

STATEMENT OF MODIFICATIONS AND DEVIATIONS 87

ANNEX..... 88

Annex A Measurement Uncertainty Calculations 89

Annex B Additional Test Equipment List 90

Annex C Rogers Qualifications 91

Annex D Rogers Labs Certificate of Accreditation 92

Revisions

Revision 2 Issued January 31, 2019 updated power listing to present total power pages 9 and 14
 Revision 1 Issued January 29, 2019

Foreword

The following information is submitted for consideration in obtaining Equipment Grants of Certification for License Exempt, Unlicensed National Information Infrastructure (U-NII) Intentional Radiator operating under 47CFR Paragraph 15E (15.407), U-NII-1 and U-NII-3, 5180-5240, and 5745-5825 MHz bands, and Industry Canada RSS-GEN Issue 5, and RSS-247 Issue 2, LE-LAN transmitter.

Name of Applicant: Mikrotikls SIA FRN: 0014431100
 Brivibas gatve 214i
 Riga Latvia LV-1039

Model: R11e-5HacD

FCC ID: TV7R11E5HAM IC: 7442A-R11E5HAM

Frequency Range: 5180-5240 MHz and 5745-5825 MHz (U-NII-1 and U-NII-3, 15.407, 802.11a (20 MHz), n (40 MHz) and ac (80 MHz) channels) and limited antenna options and power restrictions for operation in Canada

Maximum Power: U-NII-1a Band, 20 MHz mode, 0.069-watt, 99% OBW 17,500 kHz
 U-NII-1n Band, 40 MHz mode, 0.015-watt, 99% OBW 37,500 kHz
 U-NII-1ac Band, 80 MHz mode, 0.014-watt, 99% OBW 77,885 kHz
 U-NII-3a Band, 20 MHz mode, 0.194-watt, 99% OBW 17,596 kHz
 U-NII-3n Band, 40 MHz mode, 0.150-watt, 99% OBW 37,500 kHz
 U-NII-3ac Band, 80 MHz mode, 0.128-watt, 99% OBW 77,885 kHz

Opinion / Interpretation of Results

Tests Performed	Margin (dB)	Results
Restricted Frequency Bands 15.205, RSS-GEN 8.10	-2.9	Complies
AC Line Conducted 15.207, RSS-GEN 7.2.4	-3.3	Complies
Radiated Emissions 15.209, RSS-GEN 7.2.5	-4.7	Complies
Harmonic Emissions per 15.407, RSS-247	-16.3	Complies
Power Spectral Density per 15.407, RS-247	-18.0	Complies

Equipment Tested

<u>Equipment</u>	<u>Model</u>	<u>FCC ID</u>
EUT	R11e-5HacD	TV7R11E5HAM
Host device	RB912UAG-2HPnD	
AC Power Adapter	SAW30-240-0800UA	N/A
Dell Studio 1555	PP39L	N/A

Test results in this report relate only to the items tested.

Notes:

Software version: 6.43rc21 (build date May 29, 2018)

All module transmit parameters are hard coded in to the device in permanent memory. The OEM software provides integrator the ability to define gain of the antenna. The module then reduces output power to comply with country specific e.i.r.p. limits.

Antennas tested:

Omni Directional (8.5 dBi) MT-482016/N/A

Panel Antenna (24 dBi) PA58-24-ANT

Equipment Function and Configuration

The EUT is a 5 GHz (dual chain) (2x2MIMO) module operating as a License-Exempt, Unlicensed National Information Infrastructure (U NII), Local Area Network Transmission System. The design provides operational capabilities in the U-NII-1 and U-NII-3 services (5180-5240 and 5745-5825 MHz frequency bands). The EUT is provided as a PCIe interface module for incorporation into end products providing broadband wireless connectivity to transmit and receive data. Test software (Winbox version 3.18) was used to interface with and operate the transmitter during testing. This software provided the ability to set test channel, operational mode, antenna gain, and modulation. The design provides 2 mmcx antenna ports connected to short reverse polarity SMA cables for connection with authorized antenna systems. The EUT provides single mini PCIe interface for use in compatible configurations. The design operates from direct current power only and requires power provided from the associated host system. For testing purposes, the EUT was placed in a PCB card interface positioned on top of an enclosure holding the associated host device. Power was supplied to the host device which provided power to the EUT. Communications between the Host device and EUT system and the laptop computer was provided through an Ethernet network interface. This configuration provided operational control of the EUT and communications over the network interface between the host system and laptop computer. The design provides no other interfacing options than those presented in this report. For testing purposes, the R11e-5HacD test sample was configured to transmit in available data modes receiving power from the manufacturer provided host device. The EUT provides power reduction based on antenna gain information entered at time of configuration ensuring the EUT remains in compliance with regulations. As requested by the manufacturer and required by regulations, the module was tested for emissions compliance using the available configurations with the worst-case data presented. Test results in this report relate only to the products described in this report.

Equipment Configuration

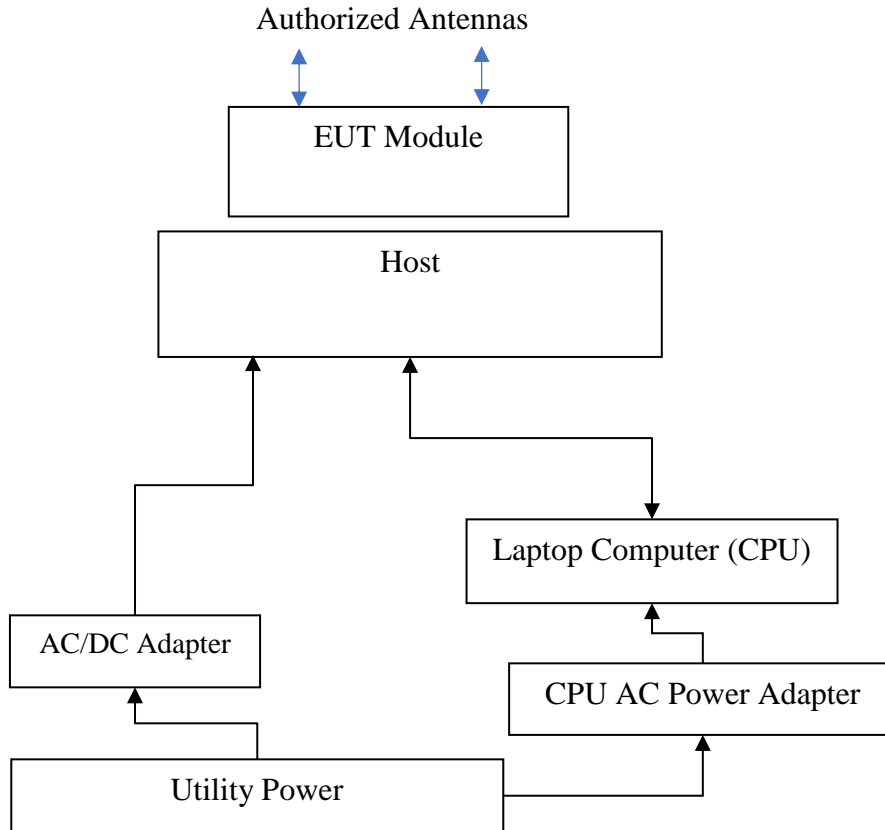

Applicant Company information

Applicants Company	MikroTik (“Mikrotīkls, SIA”)
Applicants Address	Brivibas gatve 214i, Riga Latvia LV-1039
FCC Identifier	TV7R11E5HAM
Industry Canada Identifier	7442A-R11E5HAM
Manufacturer Company	MikroTik (“Mikrotīkls, SIA”)
Manufacturer Address	Brivibas gatve 214i, Riga Latvia LV-1039

Equipment information

Product Marketing Name (PMN): The PMN is the name or model number under which the product will be marketed/offered for sale in Canada. If the product has PMN, it must be provided.	R11e-5HacD
Unique Product Number (UPN): The applicant made up of a maximum of 11 alphanumeric characters (A-Z, 0-9), assigns the UPN.	R11e-5HacD
Hardware Version Identification Number (HVIN): The HVIN identifies hardware specifications of a product version. The HVIN replaces the ISED Model Number in the legacy E-filing System. An HVIN is required for all products for certification applications.	R11e-5HacD
Host Marketing Name (HMN) (if applicable): The HMN is the name or model number of a final product, which contains a certified radio module.	RB912UAG-2HPnD
Brand Name	
Model Number	R11e-5HacD
Test Rule Part(s)	47CFR 15E, 15.407, RSS-247
Test Frequency Range	5.15-5.25 and 5.725-5.85 GHz
Project Number	181029
Submission Type	FCC and ISED Certification

Product Details

Items	Description
Product Type	Dual chain 5 GHz U-NII-1 and U-NII-3 Module
Radio Type	Transceiver
Power Type	Direct current required from Host device
Frequency Range	5150-5250 MHz / 5725-5850 MHz
Channels & Number	802.11a/n: 9 for 20MHz bandwidth; 4 for 40MHz bandwidth; and 2 for 80 MHz bandwidth 802.11 a/c
Maximum Conducted Output Power all chains	Band 1: IEEE 802.11a: 0.069 Watts IEEE 802.11n: 0.015 Watts IEEE 802.11ac: 0.014 Watts Band 3: IEEE 802.11a: 0.194 Watts IEEE 802.11n: 0.150 Watts IEEE 802.11ac: 0.128 Watts
Carrier Frequencies	Please refer to Table for Carrier Frequencies
Antenna	Omni Directional (8.5 dBi) MT-482016/N/A Panel Antenna (24 dBi) PA58-24-ANT
Communication Mode	Device provides Dual MIMO, 5 GHz, U-NII 1 and U-NII-3 operation
Beamforming Function	Without beamforming
Operating Mode	5150-5250 MHz (U-NII-1 band) and 5725-5825 MHz (U-NII-3)

Accessories

AC Power Adapter	SAW30-240-0800UA
Host device	RB912UAG-2HPnD

Table for Filed Antennas

Ant.	Brand	P/N	Antenna Type	Gain (dBi)
1	MTI Wireless Edge LTD	MT-482016/N/A	Omni	9
2	Laird Technologies	PA58-24-ANT	Panel	24

Antenna and Bandwidth

Antenna	Number of TX chains		
	20 MHz	40 MHz	80 MHz
IEEE 802.11a	1 to 2 chains	1 to 2 chains	1 to 2 chains
IEEE 802.11n	1 to 2 chains	1 to 2 chains	1 to 2 chains
IEEE 802.11ac	1 to 2 chains	1 to 2 chains	1 to 2 chains

Application for Certification

- (1) Manufacturer: Mikrotikls SIA
 Brivibas gatve 214i
 Riga Latvia LV-1039
- (2) Identification: Model: R11e-5HacD
 FCC ID: TV7R11E5HAM IC: 7442A-R11E5HAM
- (3) Instruction Book:
 Refer to Exhibit for Instruction Manual.
- (4) Description of Circuit Functions:
 Refer to Exhibit of Operational Description.
- (5) Block Diagram with Frequencies:
 Refer to Exhibit of Operational Description.
- (6) Report of Measurements:
 Report of measurements follows in this Report.
- (7) Photographs: Construction, Component Placement, etc.:
 Refer to Exhibit for photographs of equipment.
- (8) List of Peripheral Equipment Necessary for operation. The equipment operates from power received from host device. The EUT provides two antenna connection ports for use with authorized antennas. During testing, the EUT was powered from the Host device and which was connected to laptop computer through network cable.
- (9) Transition Provisions of 47CFR 15.37 are not requested
- (10) Not Applicable. The unit is not a scanning receiver.
- (11) Not Applicable. The EUT does not operate in the 59 – 64 GHz frequency band.
- (12) The equipment is not software defined and this section is not applicable.
- (13) Applications for certification of U-NII devices in the 5.15-5.35 GHz and the 5.47-5.85 GHz bands must include a high-level operational description of the security procedures that control the radio frequency operating parameters and ensure that unauthorized modifications cannot be made. The required information has been provided in Operational Description Exhibit filed with the application.
- (14) Contain at least one drawing or photograph showing the test set-up for each of the required types of tests applicable to the device for which certification is requested. These drawings or photographs must show enough detail to confirm other information contained in the test report. Any photographs used must be focused originals without glare or dark spots and must clearly show the test configuration used. This information is provided in this report and Test Setup Exhibits provided with the application filing.

Applicable Standards & Test Procedures

The following information is submitted in accordance with e-CFR dated October 29, 2018, Part 2, Subpart J, Part 15, Subpart 15E, Industry Canada RSS-GEN Issue 5, and RSS-247 Issue 2.

Test procedures used are the established Methods of Measurement of Radio-Noise Emissions as described in ANSI C63.10-2013, KDB 789033 D02 General UNII Test Procedures New Rules v02r01, KDB 662911 D01 Multiple Transmitter Output v02r01, KDB 926956 v02, KDB 996369 D01 Module Equip Auth Guide v02, RSS-247 Issue 2, and RSS-GEN Issue 5.

Equipment Testing Procedures

AC Line Conducted Emission Test Procedure

Testing for the AC line-conducted emissions was performed as defined in ANSI C63.10-2013. The test setup, including the Host device and EUT, was arranged in the test configuration as presented above. The test configuration was placed on a 1 x 1.5-meter wooden bench, 0.8 meters high located in a screen room. The power lines of the system were isolated from the power source using a standard LISN with a 50- μ Hy choke. EMI was coupled to the spectrum analyzer through a 0.1 μ F capacitor internal to the LISN. The LISN was positioned on the floor beneath the wooden bench supporting the EUT. The power lines and cables were draped over the back edge of the table. Refer to diagram one showing typical test arrangement and photographs in exhibits for EUT placement used during testing.

Radiated Emission Test Procedure

Radiated emission testing was performed as required on a CISPR 16-1-4 compliant OATS and as specified in ANSI C63.10-2013 and applicable KDB documents. The EUT was placed on a rotating 0.9 x 1.2-meter platform, elevated as required above the ground plane at a 3 meters distance from the FSM antenna. The table permitted orientation of the EUT in each of three orthogonal axis positions as necessary. EMI energy was maximized by equipment placement, raising and lowering the FSM antenna, changing the antenna polarization, and by rotating the turntable. Each emission was maximized before data was taken using a spectrum analyzer. The frequency spectrum from 9 kHz to 60,000 MHz was searched for during preliminary investigation. Refer to diagrams two and three showing typical test arrangement and photographs in the test setup exhibits for specific EUT placement during testing.

Antenna Port Conducted Emission Test Procedure

The EUT was assembled as required for operation and located on a benchtop. This configuration provided the ability to connect test equipment to the provided antenna ports. Antenna Port conducted emissions testing was performed as required in the regulations and specified in ANSI C63.10-2013. Testing was completed on a laboratory bench in a shielded room. The active antenna port of the unlicensed wireless device was connected to appropriate attenuation and the spectrum analyzer or power meter. Refer to diagram four showing typical test arrangement and photographs in the test setup exhibits for specific EUT placement during testing.

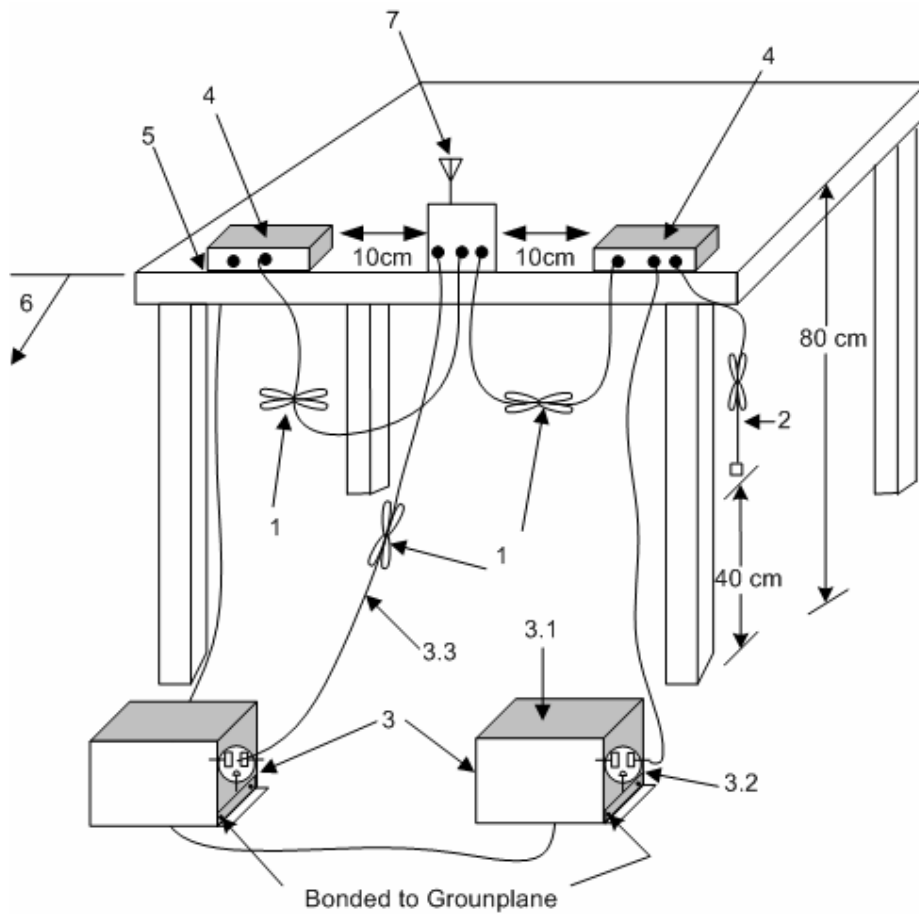

1. Interconnecting cables that hang closer than 40 cm to the ground plane shall be folded back and forth in the center forming a bundle 30 cm to 40 cm long see (see 6.2.3.2).
2. The I/O cables that are not connected to an accessory shall be bundled in the center. The end of the cable may be terminated, if required, using the correct terminating impedance. The overall length shall not exceed 1 m (see 6.2.2).
3. EUT connected to one LISN. Unused LISN measuring port connectors shall be terminated in 50 Ω loads. LISN may be placed on top of, or immediately beneath, reference ground plane (see 6.2.2 and 6.2.3).
 - 3.1 All other equipment powered from additional LISN(s).
 - 3.2 Multiple-outlet strip can be used for multiple power cords of non-EUT equipment.
 - 3.3 LISN at least 80 cm from nearest part of EUT chassis
4. Non-EUT components of EUT system being tested
5. Rear of EUT, including peripherals, shall all be aligned and flush with edge of tabletop (see 6.2.3.2).
6. Edge of tabletop shall be 40 cm removed from a vertical conducting plane that is bonded to the ground plane (see 6.2.2 for options).
7. Antenna may be integral or detachable. If detachable, the antenna shall be attached for this test.

Diagram 1 Test arrangement for Conducted emissions

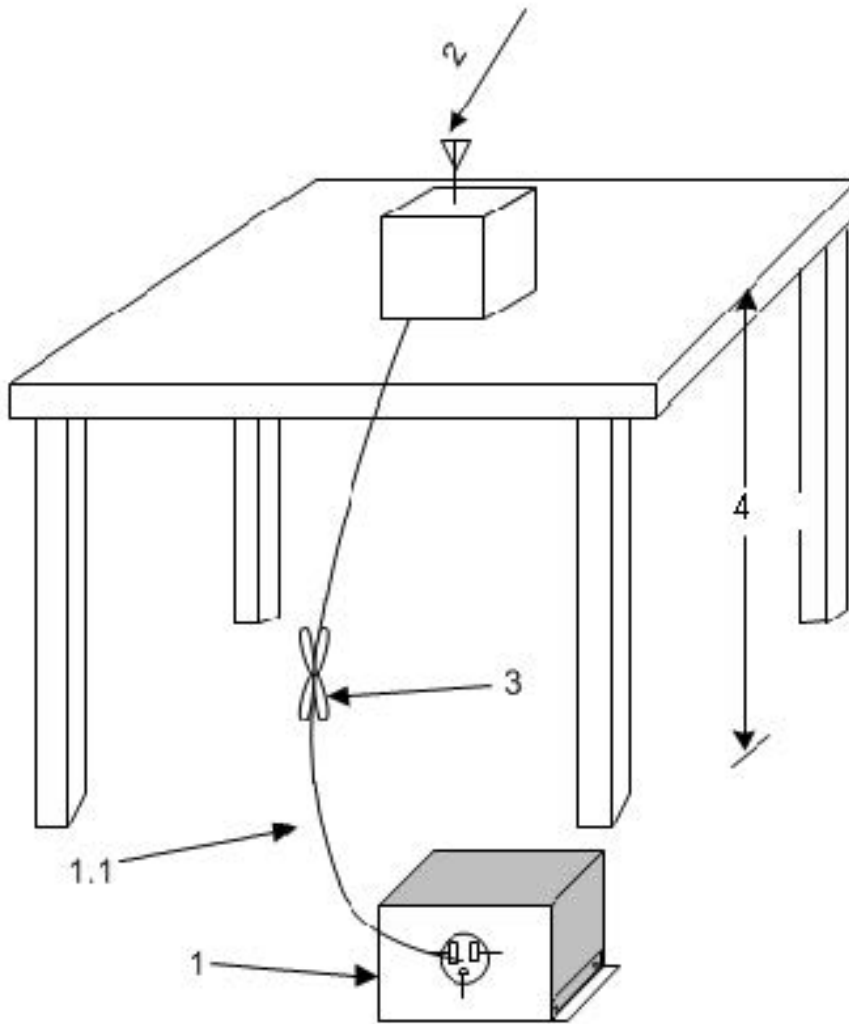

1. A LISN is optional for radiated measurements between 30 MHz and 1000 MHz but not allowed for measurements below 30 MHz and above 1000 MHz (see 6.3.1). If used, then connect EUT to one LISN. Unused LISN measuring port connectors shall be terminated in 50 Ω loads. The LISN may be placed on top of, or immediately beneath, the reference ground plane (see 6.2.2 and 6.2.3.2).
 - 1.1 LISN spaced at least 80 cm from nearest part of EUT chassis.
2. Antenna can be integral or detachable, depending on the EUT (see 6.3.1).
3. Interconnecting cables that hang closer than 40 cm to the ground plane shall be folded back and forth in the center forming a bundle 30 cm to 40 cm long (see 6.3.1).
4. For emission measurements at or below 1 GHz, the table height shall be 80 cm. For emission measurements above 1 GHz, the table height shall be 1.5 m for measurements, except as otherwise specified (see 6.3.1 and 6.6.3.1).

Diagram 2 Test arrangement for radiated emissions of tabletop equipment

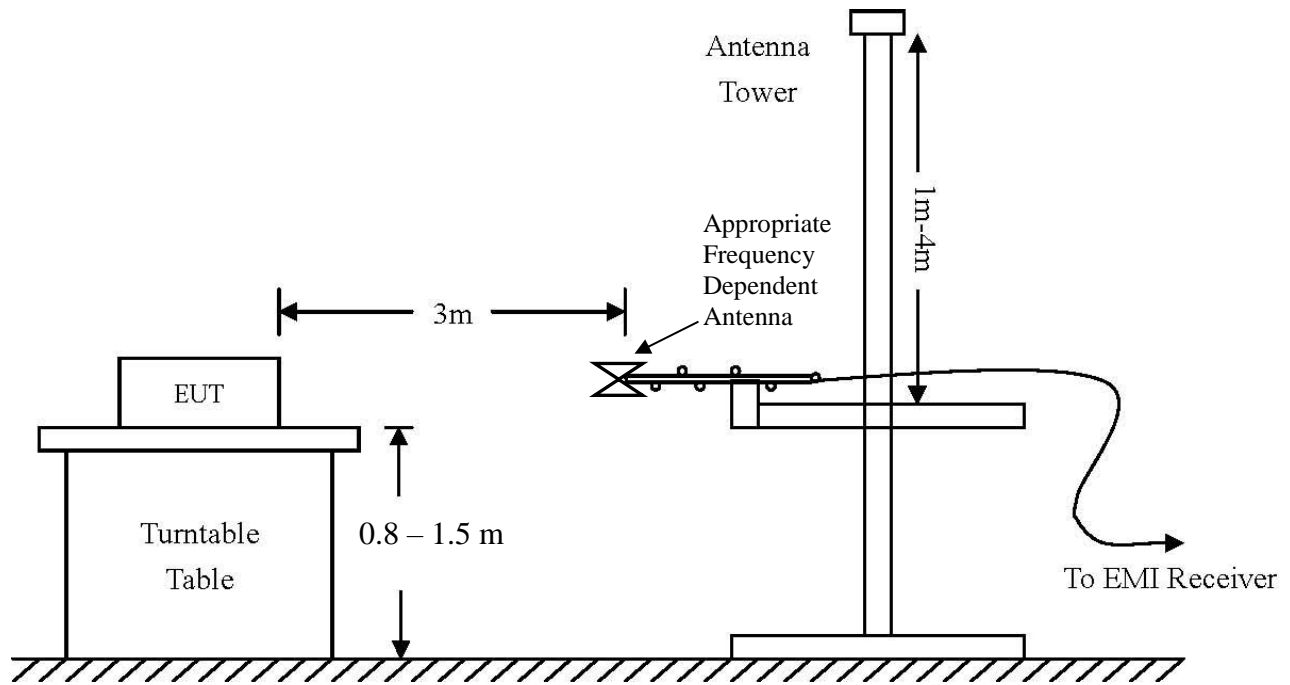

Diagram 3 Test arrangement for radiated emissions tested on Open Area Test Site (OATS)

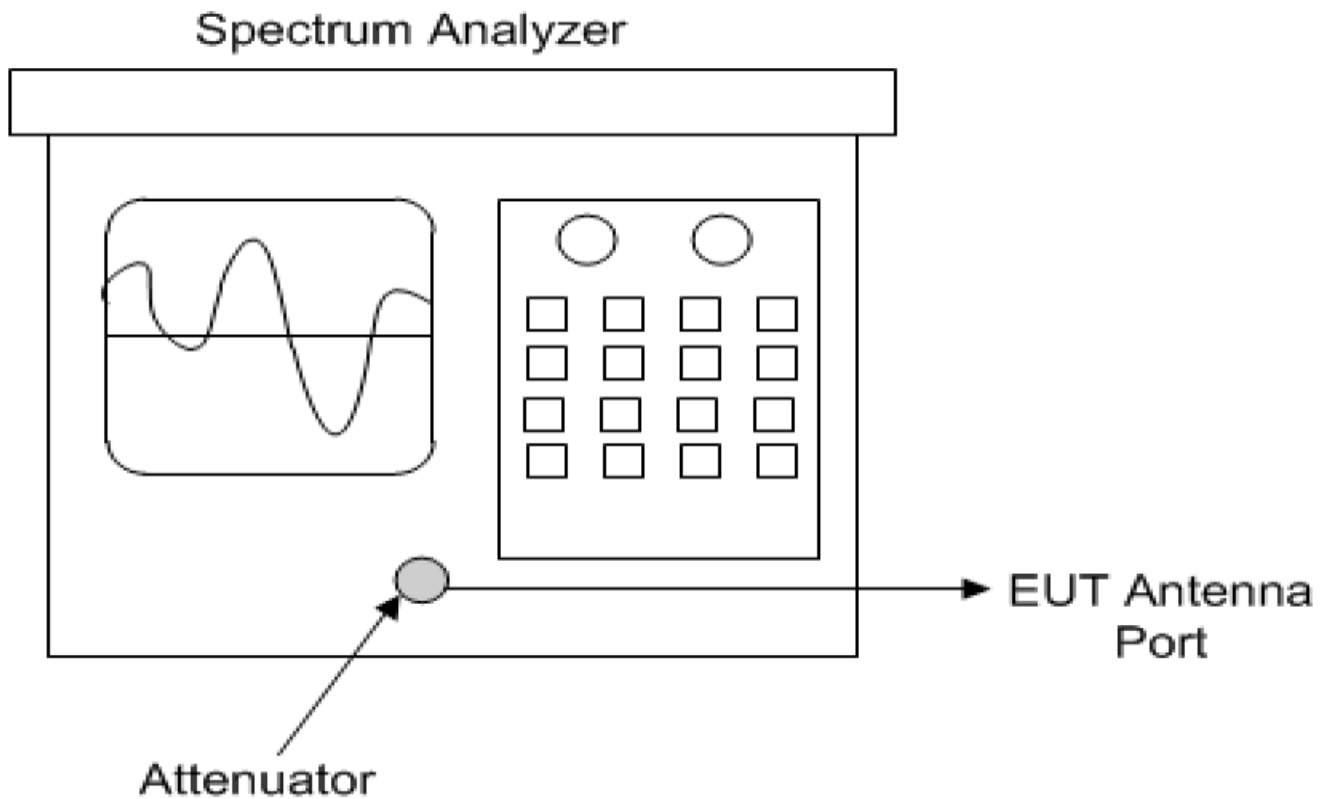

Diagram 4 Test arrangement for Antenna Port Conducted emissions

List of Test Equipment

<u>Equipment</u>	<u>Manufacturer</u>	<u>Model (SN)</u>	<u>Band</u>	<u>Cal Date(m/d/y)</u>	<u>Due</u>
<input checked="" type="checkbox"/> LISN	FCC	FCC-LISN-50-25-10(1PA) (160611)	.15-30MHz	5/2/2018	5/2/2019
<input checked="" type="checkbox"/> LISN	Compliance Design	FCC-LISN-2.Mod.cd,(126)	.15-30MHz	10/16/2018	10/16/2019
<input checked="" type="checkbox"/> Cable	Huber & Suhner Inc.	Sucoflex102ea(L10M)(303073)	9kHz-40 GHz	10/16/2018	10/16/2019
<input checked="" type="checkbox"/> Cable	Huber & Suhner Inc.	Sucoflex102ea(1.5M)(303069)	9kHz-40 GHz	10/16/2018	10/16/2019
<input checked="" type="checkbox"/> Cable	Huber & Suhner Inc.	Sucoflex102ea(1.5M)(303071)	9kHz-40 GHz	10/16/2018	10/16/2019
<input checked="" type="checkbox"/> Cable	Belden	RG-58 (L1-CAT3-11509)	9kHz-30 MHz	10/16/2018	10/16/2019
<input checked="" type="checkbox"/> Cable	Belden	RG-58 (L2-CAT3-11509)	9kHz-30 MHz	10/16/2018	10/16/2019
<input type="checkbox"/> Antenna	ARA	BCD-235-B (169)	20-350MHz	10/16/2018	10/16/2019
<input type="checkbox"/> Antenna	EMCO	3147 (40582)	200-1000MHz	10/16/2018	10/16/2019
<input checked="" type="checkbox"/> Antenna	ETS-Lindgren	3117 (200389)	1-18 GHz	5/2/2018	5/2/2020
<input type="checkbox"/> Antenna	Com Power	AH-118 (10110)	1-18 GHz	10/16/2018	10/24/2019
<input checked="" type="checkbox"/> Antenna	Com Power	AH-840 (101046)	18-40 GHz	5/15/2017	5/15/2019
<input checked="" type="checkbox"/> Antenna	Com Power	AL-130 (121055)	.001-30 MHz	10/16/2018	10/16/2019
<input checked="" type="checkbox"/> Antenna	Sunol	JB-6 (A100709)	30-1000 MHz	10/16/2018	10/16/2019
<input checked="" type="checkbox"/> Analyzer	Rohde & Schwarz	ESU40 (100108)	20Hz-40GHz	5/2/2018	5/2/2019
<input checked="" type="checkbox"/> Analyzer	Rohde & Schwarz	ESW44 (101534)	20Hz-44GHz	12/22/2017	12/22/2018
<input checked="" type="checkbox"/> Analyzer	Rohde & Schwarz	FS-Z60, 90, 140, and 220	40GHz-220GHz	12/22/2017	12/22/2019
<input checked="" type="checkbox"/> Amplifier	Com-Power	PA-010 (171003)	100Hz-30MHz	10/16/2018	10/16/2019
<input checked="" type="checkbox"/> Amplifier	Com-Power	CPPA-102 (01254)	1-1000 MHz	10/16/2018	10/16/2019
<input checked="" type="checkbox"/> Amplifier	Com-Power	PAM-118A (551014)	0.5-18 GHz	10/16/2018	10/16/2019
<input checked="" type="checkbox"/> Amplifier	Com-Power	PAM-840A (461328)	18-40 GHz	10/16/2018	10/16/2019
<input checked="" type="checkbox"/> Power Meter	Agilent	N1911A with N1921A	0.05-40 GHz	5/2/2018	5/2/2019
<input type="checkbox"/> Generator	Rohde & Schwarz	SMB100A6 (100150)	20Hz-6 GHz	5/2/2018	5/2/2019
<input type="checkbox"/> Generator	Rohde & Schwarz	SMBV100A6 (260771)	20Hz-6 GHz	5/2/2018	5/2/2019
<input type="checkbox"/> RF Filter	Micro-Tronics	BRC50722 (009) 9G notch	30-1800 MHz	5/2/2018	5/2/2019
<input type="checkbox"/> RF Filter	Micro-Tronics	HPM50114 (017) 1.5G HPF	30-18000 MHz	5/2/2018	5/2/2019
<input type="checkbox"/> RF Filter	Micro-Tronics	HPM50117 (063) 3G HPF	30-18000 MHz	5/2/2018	5/2/2019
<input type="checkbox"/> RF Filter	Micro-Tronics	HPM50105 (059) 6G HPF	30-18000 MHz	5/2/2018	5/2/2019
<input type="checkbox"/> RF Filter	Micro-Tronics	BRM50702 (172) 2G notch	30-1800 MHz	5/2/2018	5/2/2019
<input type="checkbox"/> RF Filter	Micro-Tronics	BRC50703 (G102) 5G notch	30-1800 MHz	5/2/2018	5/2/2019
<input type="checkbox"/> RF Filter	Micro-Tronics	BRC50705 (024) 5G notch	30-1800 MHz	5/2/2018	5/2/2019
<input type="checkbox"/> Attenuator	Fairview	SA6NFNF100W-14 (1625)	30-1800 MHz	5/2/2018	5/2/2019
<input type="checkbox"/> Attenuator	Mini-Circuits	VAT-3W2+ (1735)	30-6000 MHz	5/2/2018	5/2/2019
<input type="checkbox"/> Attenuator	Mini-Circuits	VAT-3W2+ (1436)	30-6000 MHz	5/2/2018	5/2/2019
<input type="checkbox"/> Attenuator	Mini-Circuits	VAT-3W2+ (14362)	30-6000 MHz	5/2/2018	5/2/2019
<input type="checkbox"/> Attenuator	Mini-Circuits	VAT-3W2+ (1445)	30-6000 MHz	5/2/2018	5/2/2019
<input type="checkbox"/> Attenuator	Mini-Circuits	VAT-3W2+ (14452)	30-6000 MHz	5/2/2018	5/2/2019
<input type="checkbox"/> Attenuator	Mini-Circuits	VAT-6W2+ (1438)	30-6000 MHz	5/2/2018	5/2/2019
<input type="checkbox"/> Attenuator	Mini-Circuits	VAT-6W2+ (1736)	30-6000 MHz	5/2/2018	5/2/2019
<input type="checkbox"/> Attenuator	JFW Industries	50FH-010-10 (1)	30-18000 MHz	5/2/2018	5/2/2019
<input checked="" type="checkbox"/> Weather station	Davis	6312 (A81120N075)		10/26/2018	10/26/2019

Rogers Labs, Inc.	Mikrotikls SIA	S/N: 8EDC0800A953/814/r2
4405 W. 259th Terrace	Model: R11e-5HacD	FCC ID: TV7R11E5HAM
Louisburg, KS 66053	Test #: 181029	IC: 7442A- R11E5HAM
Phone/Fax: (913) 837-3214	Test to: 47CFR, 15.407, RSS-247	Date: January 31, 2019
Revision 2	File: Mikrotikls R11e5HacD TstRpt 181029 r2	Page 21 of 92

Test Site Locations

Conducted EMI	Conducted emissions testing was performed in a shielded screen room located at Rogers Labs, Inc., 4405 West 259 th Terrace, Louisburg, KS
Radiated EMI	Radiated emissions tests was performed at the 3 meters, Open Area Test Site (OATS) located at Rogers Labs, Inc., 4405 West 259 th Terrace, Louisburg, KS
Site Registration	FCC Site Designation US5305, Industry Canada Registration: 3041A-1
Accreditation	NVLAP Accreditation Lab Code 200087-0

Units of Measurements

AC Line Conducted EMI	Data is in dB μ V; dB referenced to one microvolt
Antenna port Conducted	Data is in dBm; dB referenced to one milliwatt
Radiated EMI	Data is in dB μ V/m; dB/m referenced to one microvolt per meter

Sample Calculation:

RFS = Radiated Field Strength, FSM = Field Strength Measured
 A.F. = Receive antenna factor, Gain = amplification gains and/or cable losses
 $RFS (dB\mu V/m @ 3m) = FSM (dB\mu V) + A.F. (dB) - Gain (dB)$

Environmental Conditions

Ambient Temperature	23.4° C
Relative Humidity	41%
Atmospheric Pressure	1016.7 mb

Intentional Radiators

As per 47CFR subpart E and Industry Canada RSS-247 Issue 2, the following information is submitted for consideration and demonstration of compliance with regulations and standards.

Antenna Requirements

The EUT provides 2 MMCX antenna ports connected to short reverse SMA polarity cable for use in connecting authorized antenna systems. The antenna connection provision complies with the unique antenna connection requirements. The requirements of 15.203 are fulfilled there are no deviations or exceptions to the specification.

Restricted Bands of Operation

Spurious emissions falling in the restricted frequency bands of operation were measured on the OATS. The EUT utilizes frequency, determining circuitry, which generates harmonics falling in restricted bands. Emissions were investigated while the EUT was located on the OATS using appropriate antennas or pyramidal horns, amplification stages, and spectrum analyzer receiver. Peak and average amplitudes of frequencies above 1000 MHz were compared to the required limits with worst-case data presented below. Test procedures of ANSI C63.10-2013 were used during testing. No other significant emission was observed which fell into the restricted bands of operation. Computed radiated emission values consider the measured radiated field strength, receive antenna correction factor, amplifier gain stage, and test system cable losses.

Table 1 Radiated Emissions in Restricted Bands Data (802.11a) 9dBi Omni

Frequency in MHz	Horizontal Peak (dB μ V/m)	Horizontal Quasi-Peak (dB μ V/m)	Horizontal Average (dB μ V/m)	Vertical Peak (dB μ V/m)	Vertical Quasi-Peak (dB μ V/m)	Vertical Average (dB μ V/m)	Limit @ 3m (dB μ V/m)
U-NII-1 Operation Worst-case							
5150.0	49.8	N/A	35.2	62.1	N/A	44.3	54.0
5350.0	45.3	N/A	32.9	52.0	N/A	37.9	54.0
15540.0	55.2	N/A	42.0	54.7	N/A	41.7	54.0
15600.0	53.8	N/A	40.8	53.8	N/A	40.7	54.0
15720.0	57.2	N/A	43.7	55.8	N/A	43.1	54.0
U-NII-3 Operation Worst-case							
11490.0	50.2	N/A	36.8	50.8	N/A	38.0	54.0
11570.0	49.5	N/A	36.3	51.0	N/A	37.7	54.0
11650.0	50.3	N/A	37.7	52.0	N/A	38.8	54.0
22980.0	60.7	N/A	48.1	60.4	N/A	47.6	54.0

Other emissions present had amplitudes at least 20 dB below the limit. Peak and Quasi-Peak amplitude emissions are recorded above for frequency range below 1000 MHz. Peak and Average amplitude emissions are recorded above for frequency range above 1000 MHz.

Table 2 Radiated Emissions in Restricted Bands Data (802.11n) 9dBi Omni

Frequency in MHz	Horizontal Peak (dBµV/m)	Horizontal Quasi-Peak (dBµV/m)	Horizontal Average (dBµV/m)	Vertical Peak (dBµV/m)	Vertical Quasi-Peak (dBµV/m)	Vertical Average (dBµV/m)	Limit @ 3m (dBµV/m)
U-NII-1 Operation Worst-case							
5150.0	50.3	N/A	35.5	66.0	N/A	47.3	54.0
5350.0	45.9	N/A	32.9	50.7	N/A	37.5	54.0
15540.0	55.8	N/A	42.0	54.5	N/A	41.8	54.0
15600.0	53.9	N/A	40.9	54.1	N/A	40.9	54.0
15720.0	56.5	N/A	43.7	56.5	N/A	43.7	54.0
U-NII-3 Operation Worst-case							
11490.0	49.6	N/A	36.8	51.2	N/A	37.8	54.0
11570.0	49.0	N/A	36.3	51.7	N/A	37.7	54.0
11650.0	50.6	N/A	37.7	51.3	N/A	38.7	54.0
22980.0	60.5	N/A	48.1	60.2	N/A	47.7	54.0

Other emissions present had amplitudes at least 20 dB below the limit. Peak and Quasi-Peak amplitude emissions are recorded above for frequency range below 1000 MHz. Peak and Average amplitude emissions are recorded above for frequency range above 1000 MHz.

Table 3 Radiated Emissions in Restricted Bands Data (802.11n40) 9dBi Omni

Frequency in MHz	Horizontal Peak (dBµV/m)	Horizontal Quasi-Peak (dBµV/m)	Horizontal Average (dBµV/m)	Vertical Peak (dBµV/m)	Vertical Quasi-Peak (dBµV/m)	Vertical Average (dBµV/m)	Limit @ 3m (dBµV/m)
U-NII-1 Operation Worst-case							
5150.0	46.0	N/A	32.9	66.8	N/A	50.2	54.0
5350.0	45.5	N/A	32.7	48.9	N/A	35.1	54.0
15570.0	54.7	N/A	42.0	54.5	N/A	41.9	54.0
15690.0	55.4	N/A	42.4	54.7	N/A	42.2	54.0
U-NII-3 Operation Worst-case							
11510.0	49.3	N/A	36.8	50.1	N/A	36.9	54.0
11590.0	49.7	N/A	36.8	50.1	N/A	37.0	54.0
23020.0	61.1	N/A	48.3	61.5	N/A	48.2	54.0

Other emissions present had amplitudes at least 20 dB below the limit. Peak and Quasi-Peak amplitude emissions are recorded above for frequency range below 1000 MHz. Peak and Average amplitude emissions are recorded above for frequency range above 1000 MHz.

Table 4 Radiated Emissions in Restricted Bands Data (802.11ac) 9dBi Omni

Frequency in MHz	Horizontal Peak (dB μ V/m)	Horizontal Quasi-Peak (dB μ V/m)	Horizontal Average (dB μ V/m)	Vertical Peak (dB μ V/m)	Vertical Quasi-Peak (dB μ V/m)	Vertical Average (dB μ V/m)	Limit @ 3m (dB μ V/m)
U-NII-1 Operation Worst-case							
5150.0	47.5	N/A	33.7	67.7	N/A	50.3	54.0
5350.0	45.6	N/A	32.7	51.0	N/A	36.3	54.0
15630.0	52.5	N/A	39.4	52.3	N/A	39.1	54.0
20840.0	59.9	N/A	46.8	59.7	N/A	46.6	54.0
U-NII-3 Operation Worst-case							
11550.0	48.9	N/A	36.2	49.3	N/A	36.3	54.0
23100.0	60.4	N/A	47.9	61.8	N/A	47.9	54.0

Other emissions present had amplitudes at least 20 dB below the limit. Peak and Quasi-Peak amplitude emissions are recorded above for frequency range below 1000 MHz. Peak and Average amplitude emissions are recorded above for frequency range above 1000 MHz.

Table 5 Radiated Emissions in Restricted Bands Data (802.11a) 24dBi Panel

Frequency in MHz	Horizontal Peak (dBµV/m)	Horizontal Quasi-Peak (dBµV/m)	Horizontal Average (dBµV/m)	Vertical Peak (dBµV/m)	Vertical Quasi-Peak (dBµV/m)	Vertical Average (dBµV/m)	Limit @ 3m (dBµV/m)
U-NII-1 Operation Worst-case							
5150.0	46.3	N/A	33.1	70.2	N/A	50.4	54.0
5350.0	46.1	N/A	33.2	56.8	N/A	43.3	54.0
15540.0	54.7	N/A	41.8	54.8	N/A	41.8	54.0
15600.0	54.2	N/A	40.8	54.0	N/A	40.9	54.0
15720.0	55.9	N/A	43.2	57.3	N/A	43.2	54.0
U-NII-3 Operation Worst-case							
11490.0	49.7	N/A	36.8	49.9	N/A	36.8	54.0
11570.0	49.1	N/A	36.3	49.7	N/A	36.4	54.0
11650.0	50.6	N/A	37.7	50.5	N/A	37.7	54.0
22980.0	60.7	N/A	47.6	60.9	N/A	47.9	54.0

Other emissions present had amplitudes at least 20 dB below the limit. Peak and Quasi-Peak amplitude emissions are recorded above for frequency range below 1000 MHz. Peak and Average amplitude emissions are recorded above for frequency range above 1000 MHz.

Table 6 Radiated Emissions in Restricted Bands Data (802.11n) 24dBi Panel

Frequency in MHz	Horizontal Peak (dB μ V/m)	Horizontal Quasi-Peak (dB μ V/m)	Horizontal Average (dB μ V/m)	Vertical Peak (dB μ V/m)	Vertical Quasi-Peak (dB μ V/m)	Vertical Average (dB μ V/m)	Limit @ 3m (dB μ V/m)
U-NII-1 Operation Worst-case							
5150.0	46.2	N/A	33.1	70.3	N/A	51.1	54.0
5350.0	46.5	N/A	33.2	56.2	N/A	43.1	54.0
15540.0	54.6	N/A	41.9	55.1	N/A	42.1	54.0
15600.0	54.4	N/A	41.0	53.7	N/A	40.8	54.0
15720.0	56.0	N/A	43.2	55.8	N/A	43.2	54.0
U-NII-3 Operation Worst-case							
11490.0	49.8	N/A	36.8	49.9	N/A	36.8	54.0
11570.0	50.1	N/A	36.4	49.1	N/A	36.4	54.0
11650.0	51.0	N/A	37.7	50.4	N/A	37.7	54.0
22980.0	60.6	N/A	47.8	60.7	N/A	47.5	54.0

Other emissions present had amplitudes at least 20 dB below the limit. Peak and Quasi-Peak amplitude emissions are recorded above for frequency range below 1000 MHz. Peak and Average amplitude emissions are recorded above for frequency range above 1000 MHz.

Table 7 Radiated Emissions in Restricted Bands Data (802.11n40) 24dBi Panel

Frequency in MHz	Horizontal Peak (dB μ V/m)	Horizontal Quasi-Peak (dB μ V/m)	Horizontal Average (dB μ V/m)	Vertical Peak (dB μ V/m)	Vertical Quasi-Peak (dB μ V/m)	Vertical Average (dB μ V/m)	Limit @ 3m (dB μ V/m)
U-NII-1 Operation Worst-case							
5150.0	45.6	N/A	32.7	66.1	N/A	49.6	54.0
5350.0	45.3	N/A	32.7	50.6	N/A	37.4	54.0
15570.0	55.1	N/A	42.0	55.3	N/A	42.0	54.0
15690.0	55.1	N/A	42.1	54.9	N/A	42.1	54.0
U-NII-3 Operation Worst-case							
11510.0	49.4	N/A	36.8	49.7	N/A	36.8	54.0
11590.0	49.8	N/A	36.8	49.7	N/A	36.8	54.0
23020.0	61.2	N/A	48.2	60.9	N/A	48.0	54.0

Other emissions present had amplitudes at least 20 dB below the limit. Peak and Quasi-Peak amplitude emissions are recorded above for frequency range below 1000 MHz. Peak and Average amplitude emissions are recorded above for frequency range above 1000 MHz.

Table 8 Radiated Emissions in Restricted Bands Data (802.11ac) 24dBi Panel

Frequency in MHz	Horizontal Peak (dBµV/m)	Horizontal Quasi-Peak (dBµV/m)	Horizontal Average (dBµV/m)	Vertical Peak (dBµV/m)	Vertical Quasi-Peak (dBµV/m)	Vertical Average (dBµV/m)	Limit @ 3m (dBµV/m)
U-NII-1 Operation Worst-case							
5150.0	46.8	N/A	33.4	67.4	N/A	50.4	54.0
5350.0	45.8	N/A	32.7	51.4	N/A	38.0	54.0
15630.0	53.0	N/A	39.4	52.6	N/A	39.5	54.0
20840.0	56.2	N/A	43.5	56.4	N/A	43.7	54.0
U-NII-3 Operation Worst-case							
11550.0	49.1	N/A	36.2	49.4	N/A	36.2	54.0
23100.0	61.5	N/A	47.9	61.3	N/A	47.9	54.0

Other emissions present had amplitudes at least 20 dB below the limit. Peak and Quasi-Peak amplitude emissions are recorded above for frequency range below 1000 MHz. Peak and Average amplitude emissions are recorded above for frequency range above 1000 MHz.

Summary of Results for Radiated Emissions in Restricted Bands

The EUT demonstrated compliance with the emissions requirements of 47CFR 15.205, RSS-GEN Issue 5, and RSS-247 Issue 2. The EUT provided a worst-case minimum margin of -2.9 dB below the emissions requirements in restricted frequency bands. Peak, Quasi-peak, and average amplitudes were checked for compliance with the regulations. Worst-case emissions are reported with other emissions found in the restricted frequency bands at least 20 dB below the requirements.

AC Line Conducted Emissions Procedure

The EUT and support host was arranged in a typical equipment configuration and placed on a 1 x 1.5-meter wooden bench 80 cm above the conducting ground plane, floor of a screen room. The bench was positioned 40 cm away from the wall of the screen room. The LISN was positioned on the floor of the screen room 80-cm from the rear of the EUT. The manufacturer supplied AC/DC adapter was connected to the LISN and provided direct current power to the host and powered the test sample. A second LISN was positioned on the floor of the screen room 80-cm from the rear of the supporting equipment of the EUT. All power cords except the EUT were then powered from the second LISN. EMI was coupled to the spectrum analyzer through a 0.1 µf capacitor, internal to the LISN. Power line conducted emissions testing were carried out individually for each current carrying conductor of the host system for the EUT. The excess length of lead between the system and the LISN receptacle was folded back and forth to form a bundle not exceeding 40 cm in length. The screen room, conducting ground plane, analyzer, and LISN were bonded together to the protective earth ground. Preliminary testing was performed to identify the frequency of each emission displaying the highest amplitude. The cables were repositioned to obtain maximum amplitude of measured EMI level. Once the worst-case configuration was identified, plots were made of the EMI from 0.15 MHz to 30 MHz then the data was recorded with maximum conducted emissions levels.

Refer to figures one and two for plots of the EUT and host system AC Line Conducted emissions.

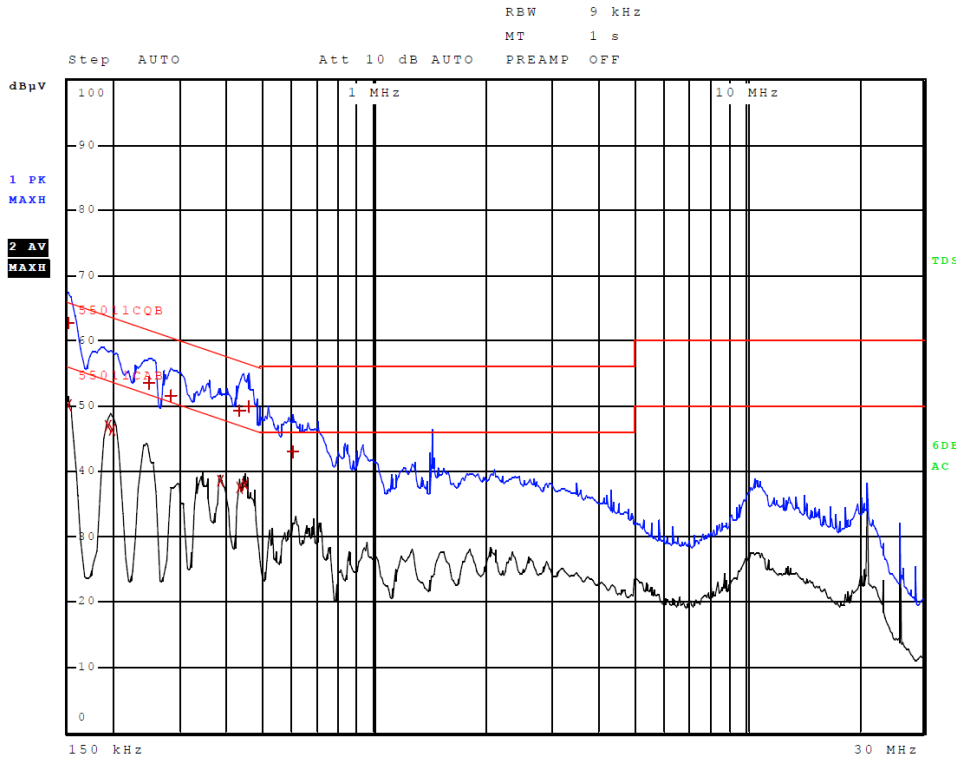

Figure 1 AC Line Conducted Emissions Line 1

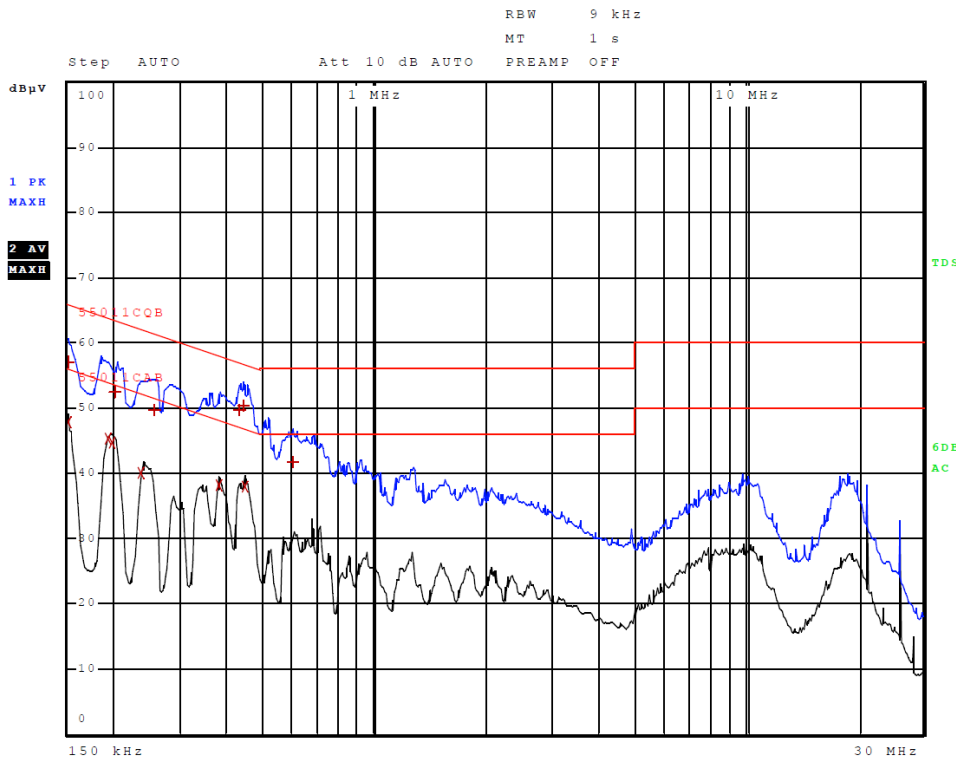

Figure 2 AC Line Conducted Emissions Line 2

Table 9 AC Line Conducted Emissions Data (Line L1)

Trace	Frequency	Level (dBµV)	Detector	Delta Limit/dB
1	150.000000000 kHz	62.70	Quasi Peak	-3.30
2	150.000000000 kHz	50.07	Average	-5.93
2	194.000000000 kHz	46.92	Average	-6.95
2	198.000000000 kHz	46.23	Average	-7.47
1	250.000000000 kHz	53.56	Quasi Peak	-8.20
1	282.000000000 kHz	51.60	Quasi Peak	-9.15
2	382.000000000 kHz	38.49	Average	-9.75
1	430.000000000 kHz	49.16	Quasi Peak	-8.09
2	430.000000000 kHz	37.58	Average	-9.67
2	446.000000000 kHz	37.92	Average	-9.03
1	458.000000000 kHz	49.81	Quasi Peak	-6.92
1	598.000000000 kHz	43.00	Quasi Peak	-13.00

Other emissions present had amplitudes at least 20 dB below the limit.

Table 10 AC Line Conducted Emissions Data (Line L2)

Trace	Frequency	Level (dBµV)	Detector	Delta Limit/dB
1	150.000000000 kHz	57.00	Quasi Peak	-9.00
2	150.000000000 kHz	47.77	Average	-8.23
2	194.000000000 kHz	45.26	Average	-8.60
2	198.000000000 kHz	44.62	Average	-9.08
1	202.000000000 kHz	52.46	Quasi Peak	-11.07
2	238.000000000 kHz	40.11	Average	-12.06
1	258.000000000 kHz	49.60	Quasi Peak	-11.90
2	378.000000000 kHz	38.18	Average	-10.14
1	430.000000000 kHz	49.77	Quasi Peak	-7.48
1	442.000000000 kHz	50.23	Quasi Peak	-6.80
2	446.000000000 kHz	37.83	Average	-9.11
1	598.000000000 kHz	41.66	Quasi Peak	-14.34

Other emissions present had amplitudes at least 20 dB below the limit.

Summary of Results for AC Line Conducted Emissions

The EUT test system demonstrated compliance to the conducted emissions requirements of 47CFR 15.207, RSS-247 Issue 2 and RSS-GEN. The EUT and host support system demonstrated minimum margin of -3.3 dB below the limit. Measurements were taken using the peak, quasi peak, and average, measurement function for each emissions amplitude and were below the limits stated in the specification. Other emissions were present with recorded data representing worst-case amplitudes.

General Radiated Emissions Procedure

The EUT was arranged in a typical equipment configuration and operated through all available modes with worst-case data recorded. Preliminary testing was performed in a screen room with the EUT positioned 1 meter from the FSM. Radiated emissions measurements were performed to identify the frequencies, which produced the highest emissions. Each radiated emission was then maximized at the OATS location before final radiated emissions measurements were performed. Final data was taken with the EUT located at the OATS at a 3 meters distance between the EUT and the receiving antenna. The frequency spectrum from 9 kHz to 60,000 MHz was searched for general radiated emissions. Measured emission levels were maximized by EUT placement on the table, rotating the turntable through 360 degrees, varying the antenna height between 1 and 4 meters above the ground plane and changing antenna position between horizontal and vertical polarization. Antennas used were Loop from 9 kHz to 30 MHz, Broadband Biconical from 30 to 200 MHz, Biconilog from 30 to 1000 MHz, Log Periodic from 200 MHz to 1 GHz and or Double Ridge or pyramidal horns and mixers above 1 GHz, notch filters, and appropriate amplifiers and external mixers were utilized.

Table 11 General Radiated Emissions from EUT Data

Frequency in MHz	Horizontal Peak (dB μ V/m)	Horizontal Quasi-Peak (dB μ V/m)	Horizontal Average (dB μ V/m)	Vertical Peak (dB μ V/m)	Vertical Quasi-Peak (dB μ V/m)	Vertical Average (dB μ V/m)	Limit @ 3m (dB μ V/m)
53.2	39.4	33.8	N/A	40.2	34.7	N/A	40.0
54.1	40.3	34.5	N/A	40.6	35.0	N/A	40.0
72.9	41.6	34.8	N/A	41.6	34.6	N/A	40.0
77.6	39.2	31.8	N/A	38.7	32.7	N/A	40.0
82.3	36.7	30.9	N/A	41.8	35.1	N/A	43.5
125.0	40.6	38.8	N/A	42.2	38.6	N/A	43.5
375.0	26.9	23.1	N/A	23.5	18.4	N/A	46.0
625.0	28.8	24.2	N/A	31.8	27.4	N/A	46.0

Other emissions present had amplitudes at least 20 dB below the limit. Peak and Quasi-Peak amplitude emissions are recorded above for frequency range below 1000 MHz. Peak and Average amplitude emissions are recorded above for frequency range above 1000 MHz.

Summary of Results for General Radiated Emissions

The EUT demonstrated compliance with the radiated emissions requirements of 47CFR part 15 and Industry Canada RSS-247 Issue 2 Intentional Radiators. The EUT demonstrated a minimum margin of -4.7 dB below the requirements. Other emissions were present with amplitudes at least 20 dB below the Limits.

Operation in the 5150-5250 and 5725-5850 MHz Frequency U-NII-1 and U-NII-3 Bands

Testing followed FCC 789033 D02 General U-NII Test Procedures New Rules v02r01.

A power meter was used to measure fundamental transmitter output power. A spectrum analyzer / receiver was used to produce plots and make other antenna port conducted measurements for compliance testing. Test software (Winbox version 3.18) was used to operate the transmitter. This software provided the ability to set test channel, operational mode, and modulation scheme. The software was configured using 0-dBi gain antenna during antenna port conducted testing and antenna gain information was entered during radiated emissions testing. Each antenna port was connected to coaxial cable with 50-ohm attenuator, receiver, spectrum analyzer, or power meter during testing. Radiated emissions testing was performed on the Open Area Test Site (OATS) with all transmitters operating. The test sample was placed on a turntable elevated as required above the ground plane as required at a 3 meters distance from the FSM antenna located on the OATS for testing radiated emissions. The peak and quasi-peak amplitude of the frequencies below 1000 MHz were measured using a spectrum analyzer. The peak and average amplitude of emissions above 1000 MHz were measured using a spectrum analyzer. Emissions data was recorded from the measurement results. Data presented reflects measurement result corrected to account for measurement system gains and losses. Plots were made of transmitter performance for reference and demonstration of compliance. In addition, all Manufacturers of U-NII devices are responsible for ensuring frequency stability such that the emissions are maintained within the band of operation under all conditions of normal operation as specified in the user's manual. The manufacturer has attested the equipment operates within the required frequency spectrum under normal operational conditions. This report documents emissions governed under the U-NII-1 and U-NII-3 bands operating in the 5180-5240 and 5745-5825 MHz frequency bands.

Directional correlated antenna calculation (antenna gain 9 dBi, and 2 chains). Per KDB 662911 D01 Multiple Transmitter Output v02r01, the directional gain for correlated emissions in-band may be calculated using the following formula:

$$\text{Directional gain} = G_{\text{ANT}} + 10 \log (N_{\text{ANT}}) \text{ dBi}$$

$$\text{Directional gain} = 9 + 10 \log (2) \text{ dBi} = 12 \text{ dBi}$$

Per 15.407 Technical Requirements

(a) power limitations

(1) For the Band 5.15-5.25 GHz

- (i) For an outdoor access point operating in the band 5.15-5.25 GHz, the maximum conducted output power over the frequency band of operation shall not exceed 1 W provided the maximum antenna gain does not exceed 6 dBi. In addition, the maximum power spectral density shall not exceed 17 dBm in any 1 megahertz band. If transmitting antennas of directional gain greater than 6 dBi are used, both the maximum conducted output power and the maximum power spectral density shall be reduced by the amount in dB that the directional gain of the antenna exceeds 6 dBi. The maximum e.i.r.p. at any elevation angle above 30 degrees as measured from the horizon must not exceed 125 mW (21 dBm).

Per RSS-247 Issue 2

6. Technical requirements for license-exempt local area network devices and digital transmission systems operating in the 5 GHz band

This section provides standards for License-Exempt Local Area Network (LE-LAN) devices operating in the bands 5150-5250 MHz, 5250-5350 MHz, 5470-5600 MHz, 5650-5725 MHz and 5725-5850 MHz and for DTSs operating in the band 5725-5850 MHz that employ digital modulation technology but are not designed for LE-LAN operation.

Devices with occupied bandwidths which overlap different bands shall comply with all operational requirements for each band.

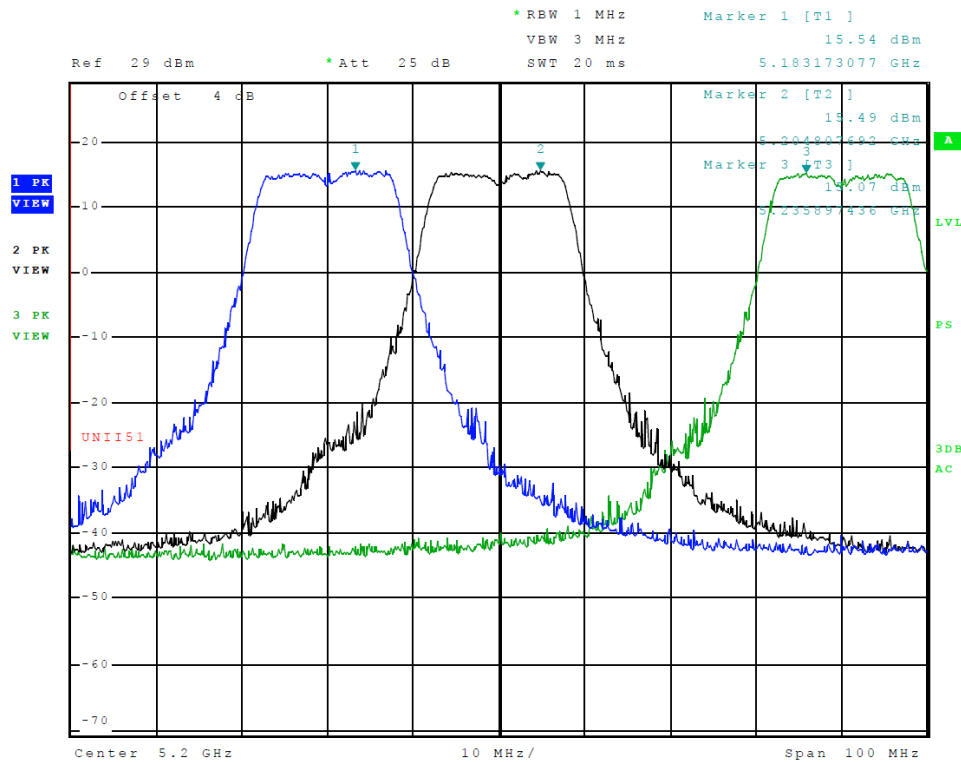

Figure 3 Plot of Transmitter Emissions (Across 5150-5250 MHz Band, Chain 0, 802.11a)

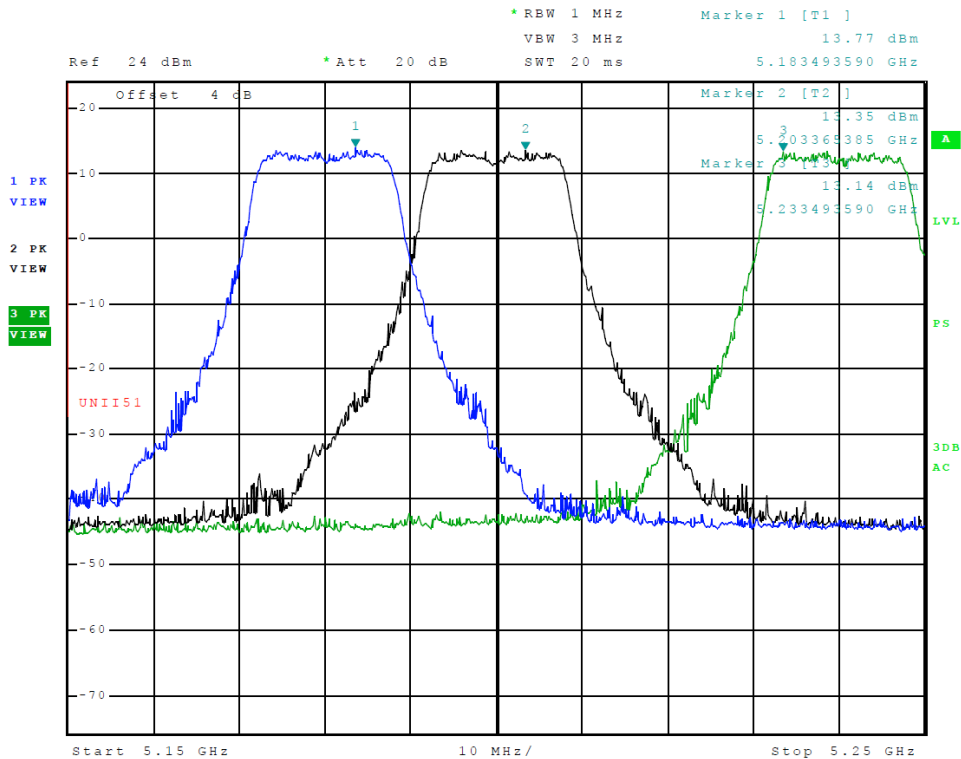

Figure 4 Plot of Transmitter Emissions (Across 5150-5250 MHz Band, Chain 1, 802.11a)

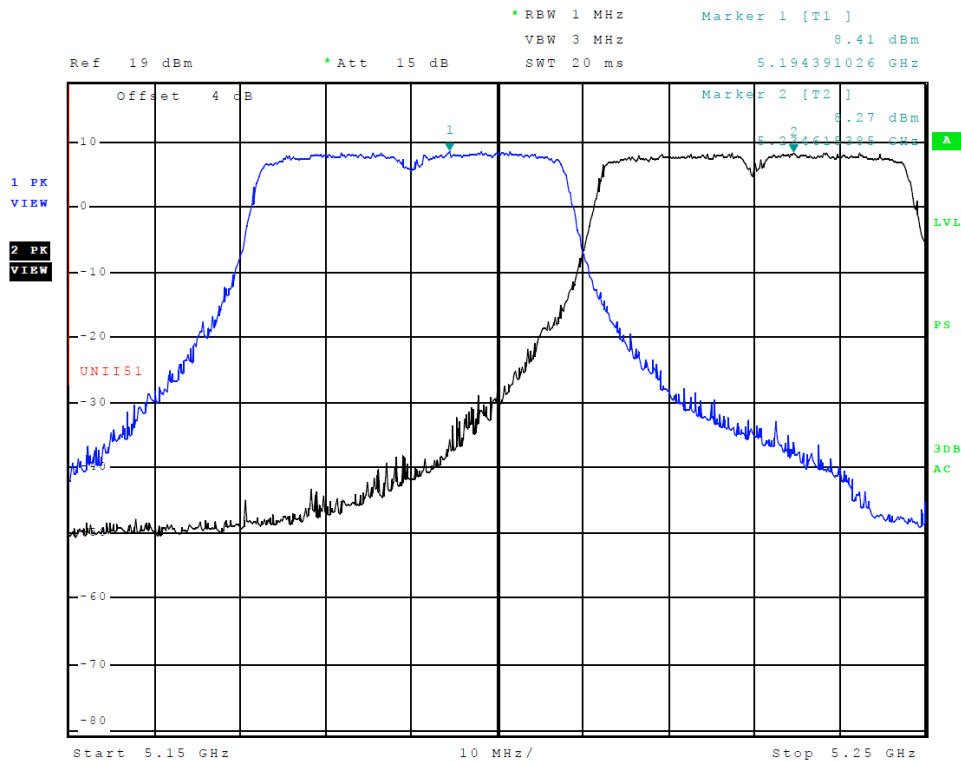

Figure 5 Plot of Transmitter Emissions (Across 5150-5250 MHz Band, Chain 0, 802.11n40)

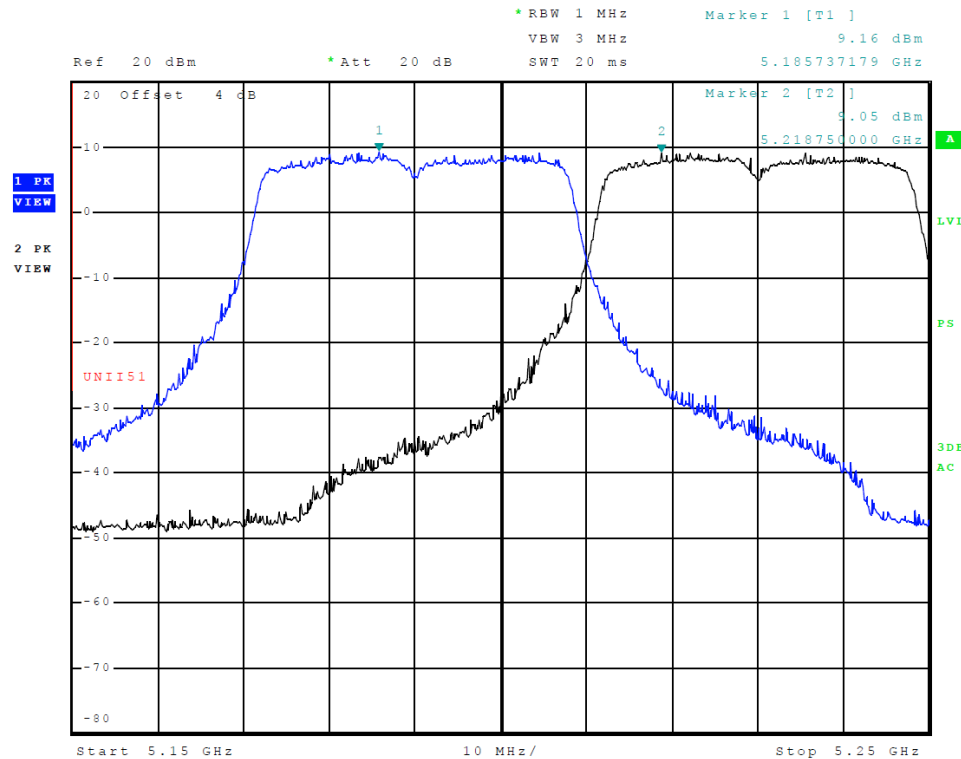

Figure 6 Plot of Transmitter Emissions (Across 5150-5250 MHz Band, Chain 1, 802.11n40)

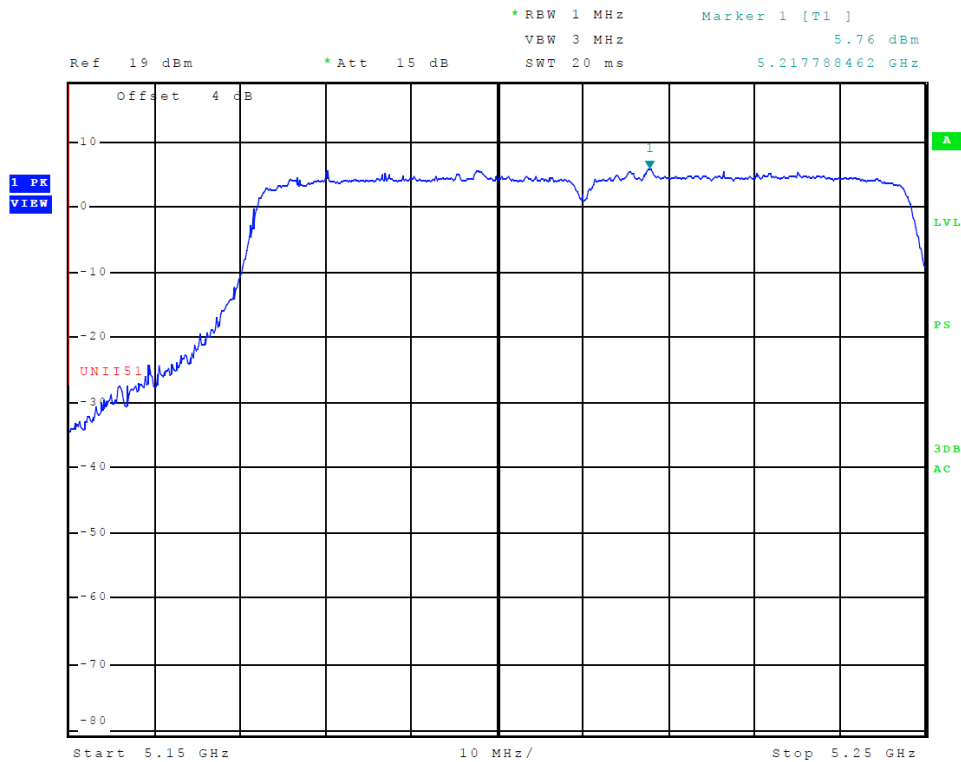

Figure 7 Plot of Transmitter Emissions (Across 5150-5250 MHz Band, Chain 0, 802.11ac)

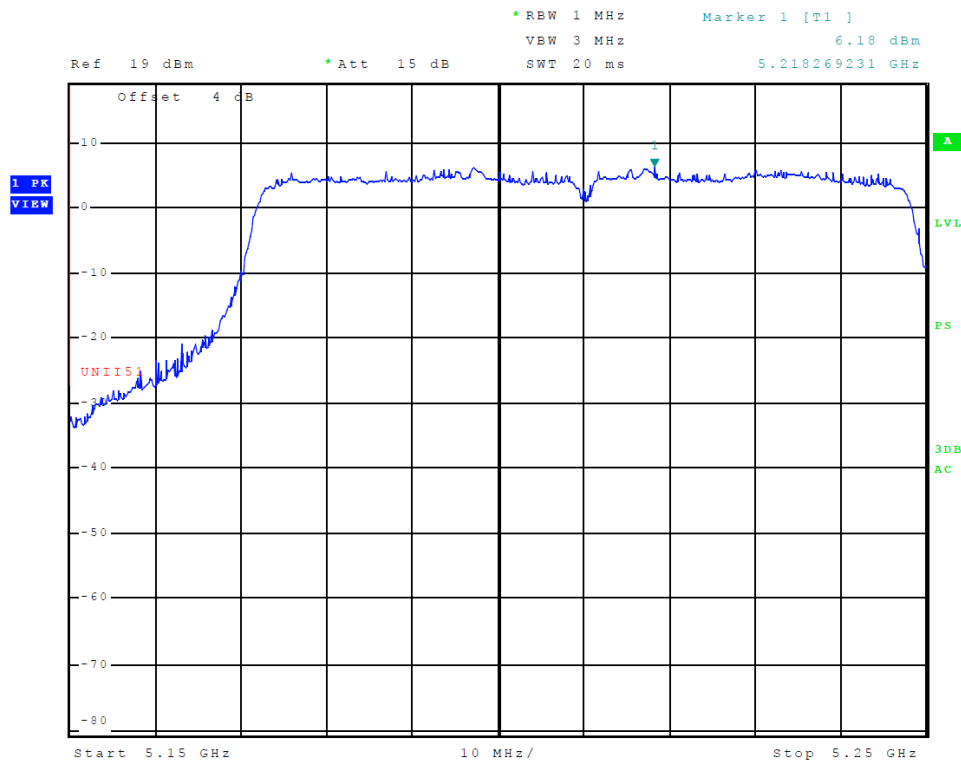

Figure 8 Plot of Transmitter Emissions (Across 5150-5250 MHz Band, Chain 1, 802.11ac)

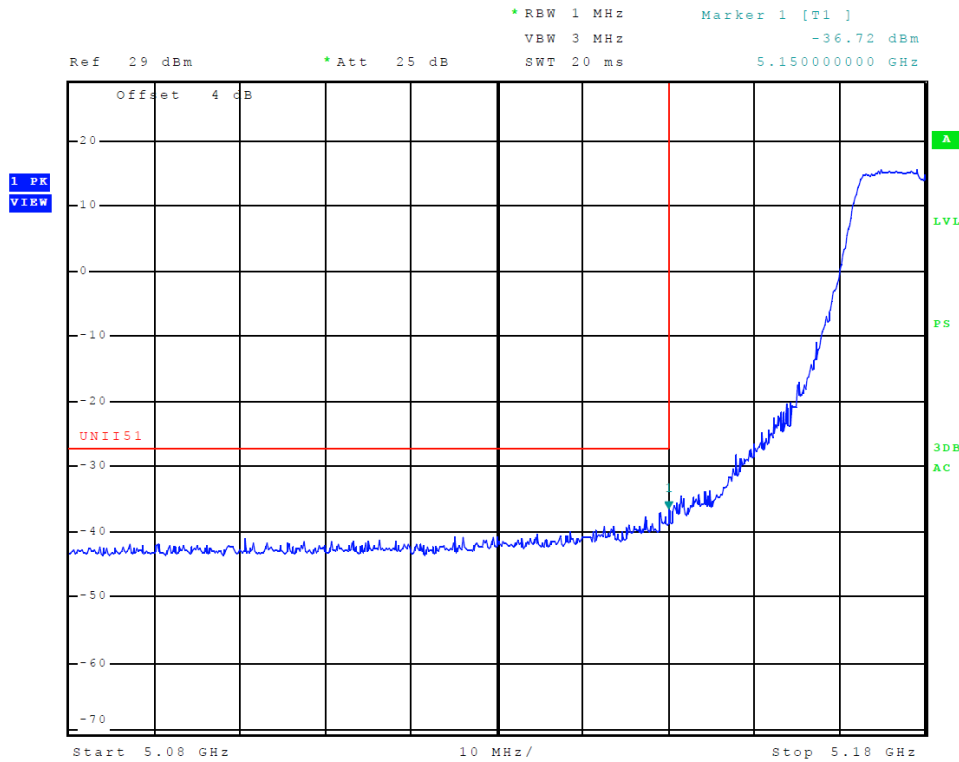

Figure 9 Plot of Transmitter Low Band Edge (5150-5250 MHz Band, Chain 0, 802.11a)

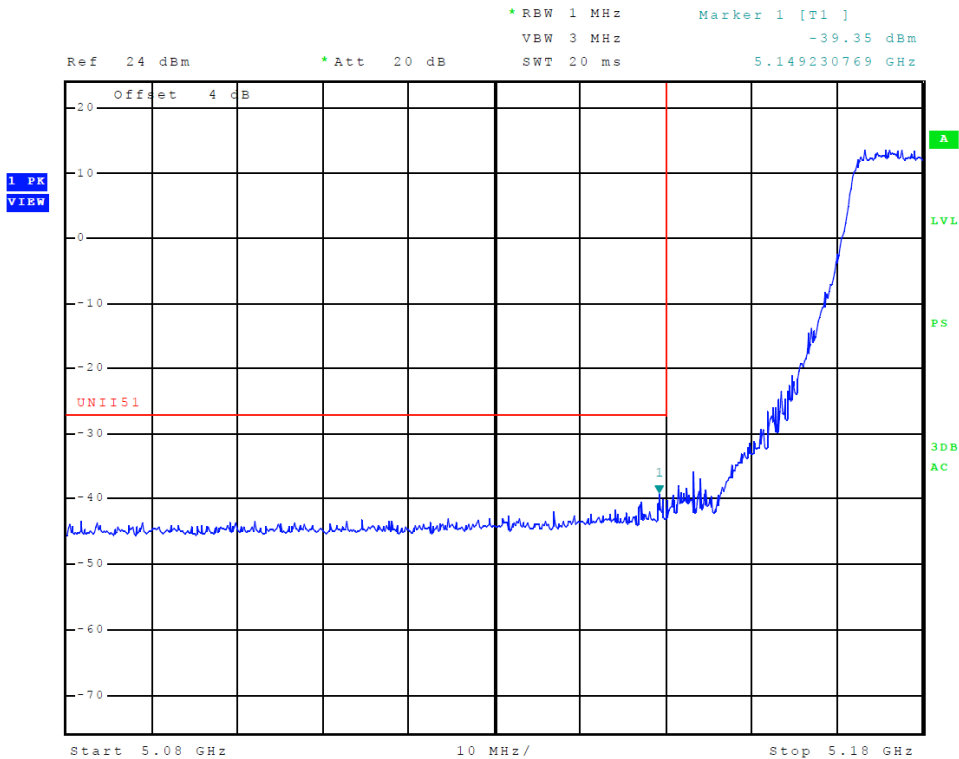

Figure 10 Plot of Transmitter Low Band Edge (5150-5250 MHz Band, Chain 1, 802.11a)

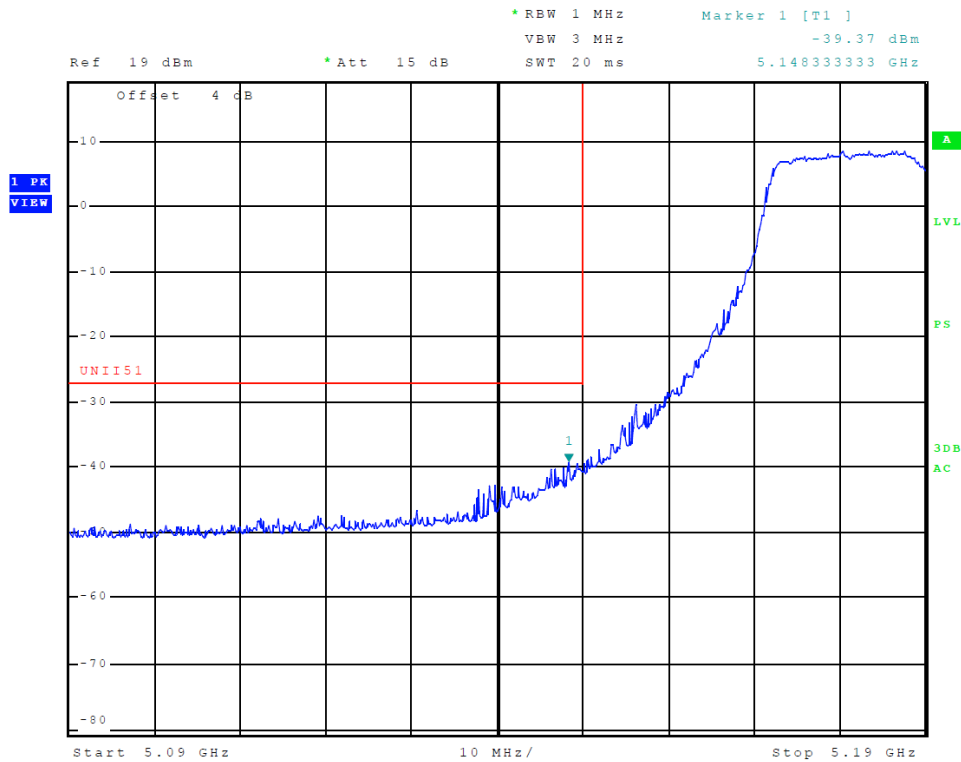

Figure 11 Plot of Transmitter Low Band Edge (5150-5250 MHz Band, Chain 0, 802.11n40)

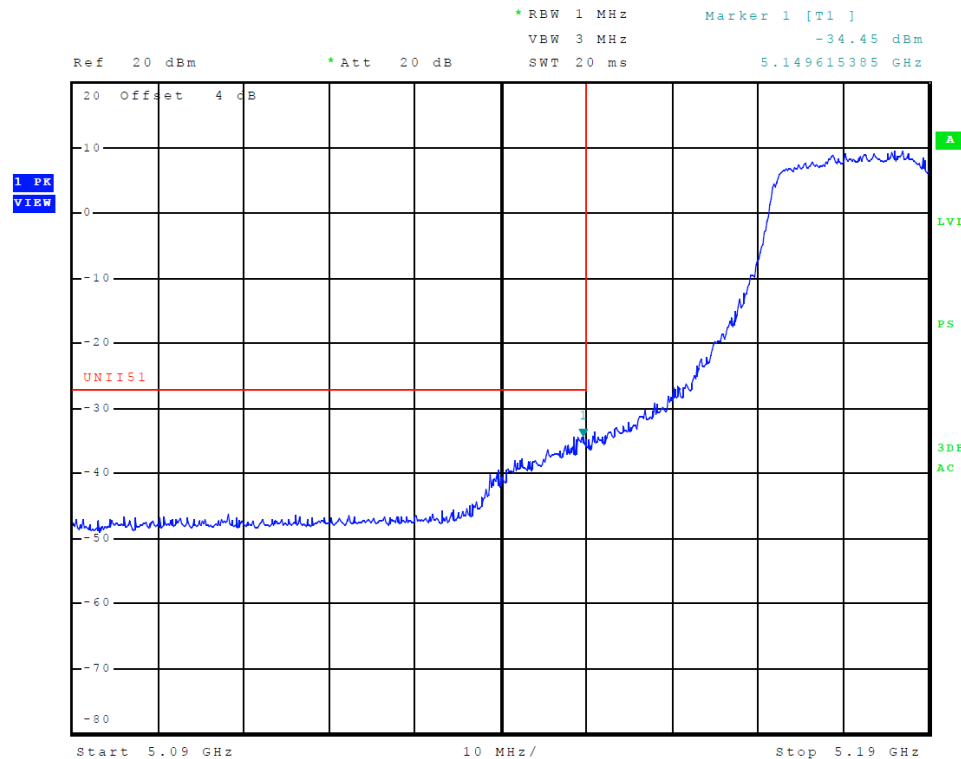

Figure 12 Plot of Transmitter Low Band Edge (5150-5250 MHz Band, Chain 1, 802.11n40)

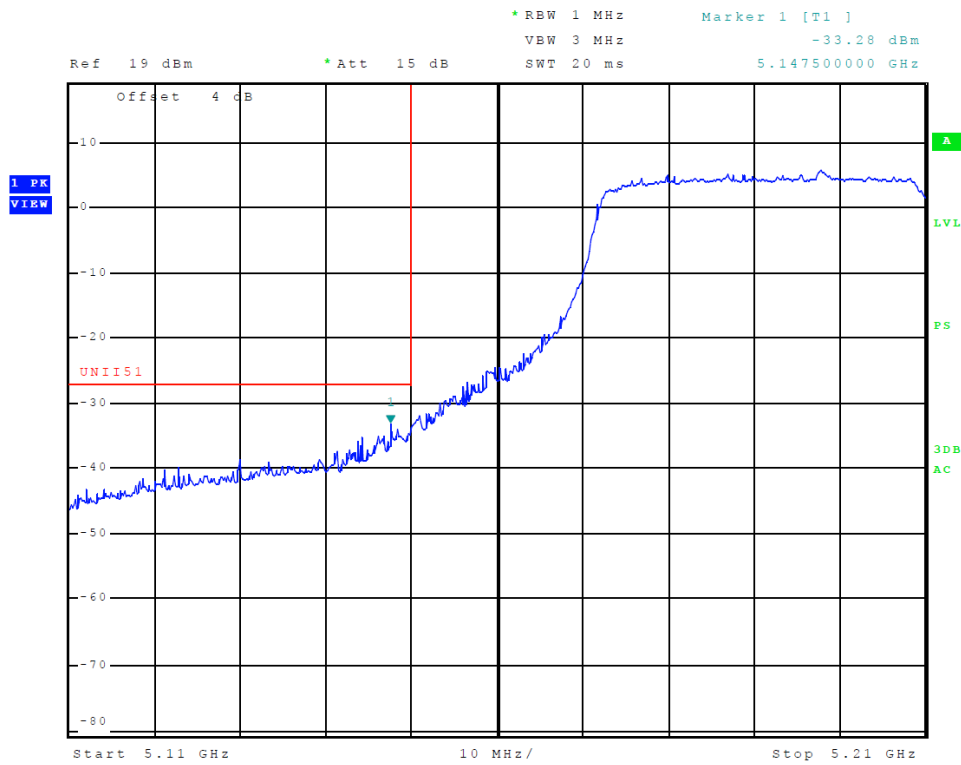

Figure 13 Plot of Transmitter Low Band Edge (5150-5250 MHz Band, Chain 0, 802.11ac)

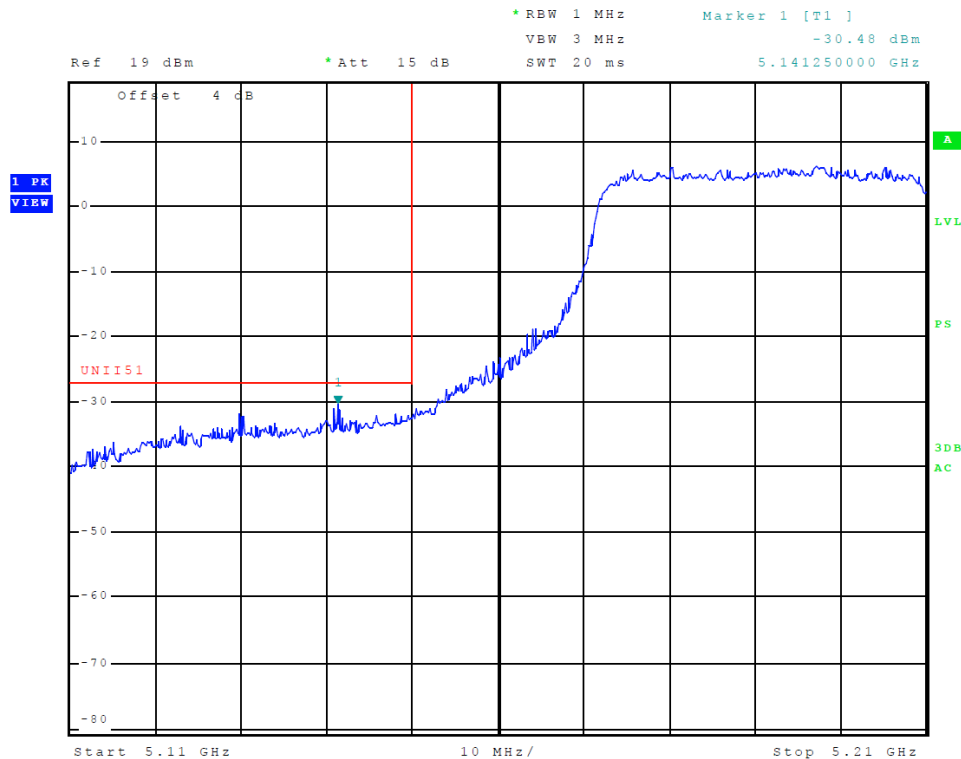

Figure 14 Plot of Transmitter Low Band Edge (5150-5250 MHz Band, Chain 1, 802.11ac)

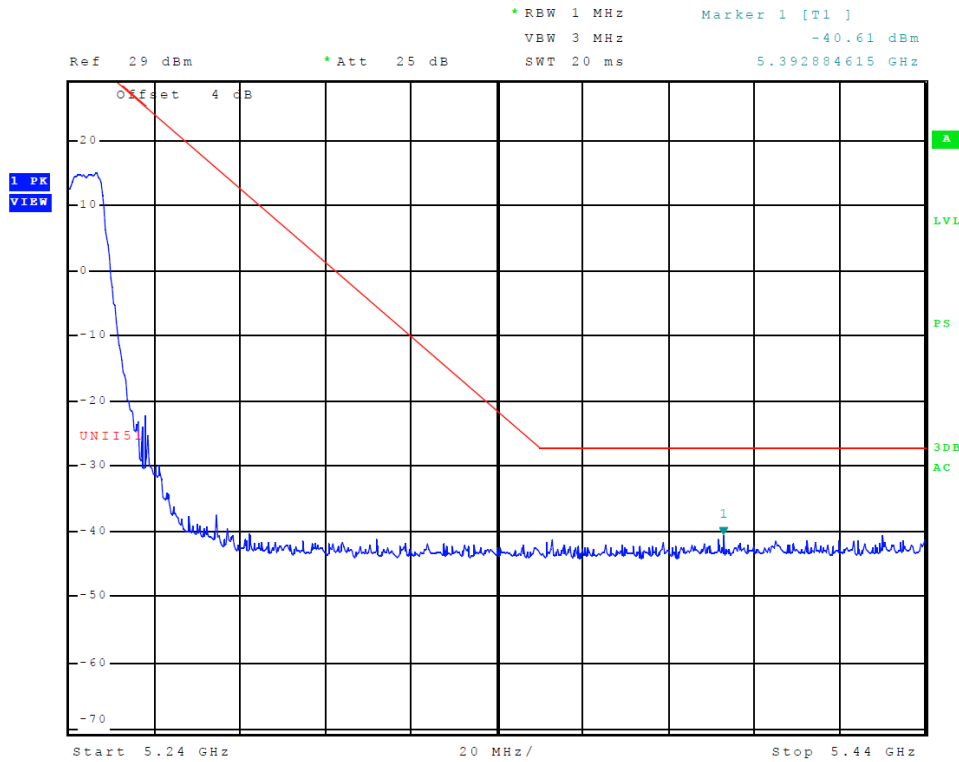

Figure 15 Plot of Transmitter High Band Edge (5150-5250 MHz Band, Chain 0, 802.11a)

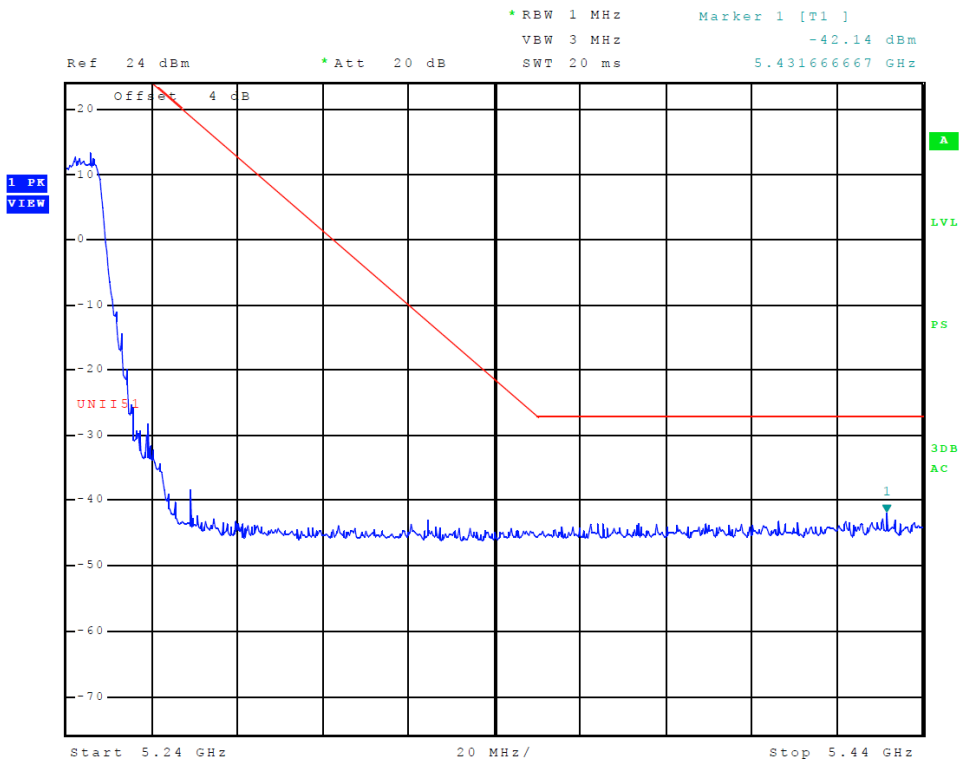

Figure 16 Plot of Transmitter High Band Edge (5150-5250 MHz Band, Chain 1, 802.11a)

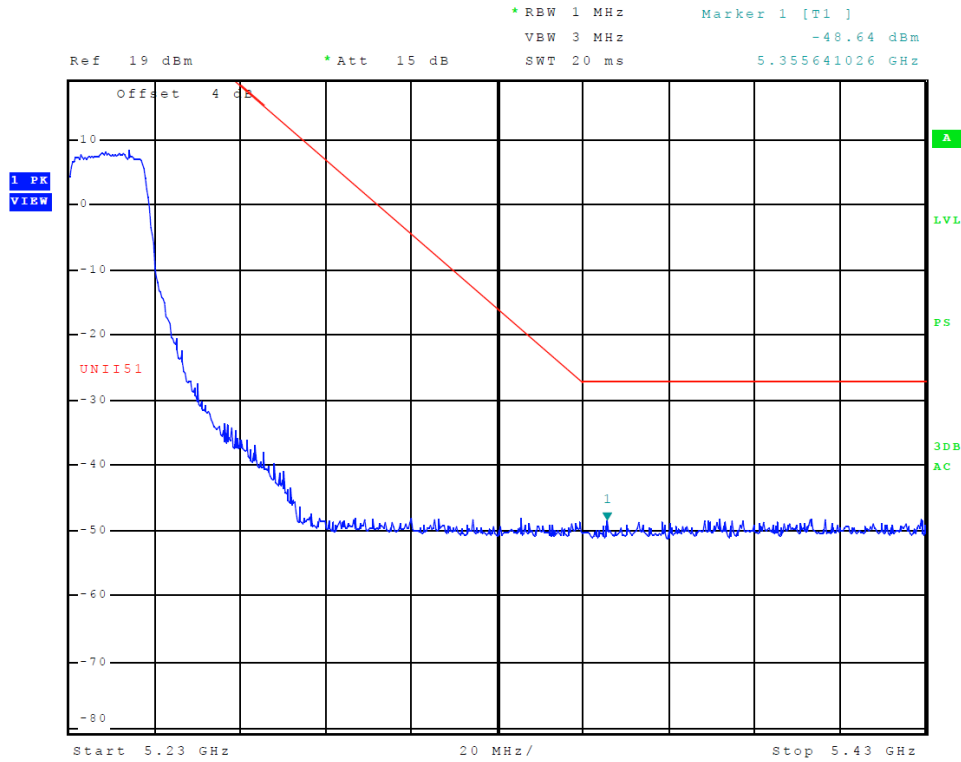

Figure 17 Plot of Transmitter High Band Edge (5150-5250 MHz Band, Chain 0, 802.11n40)

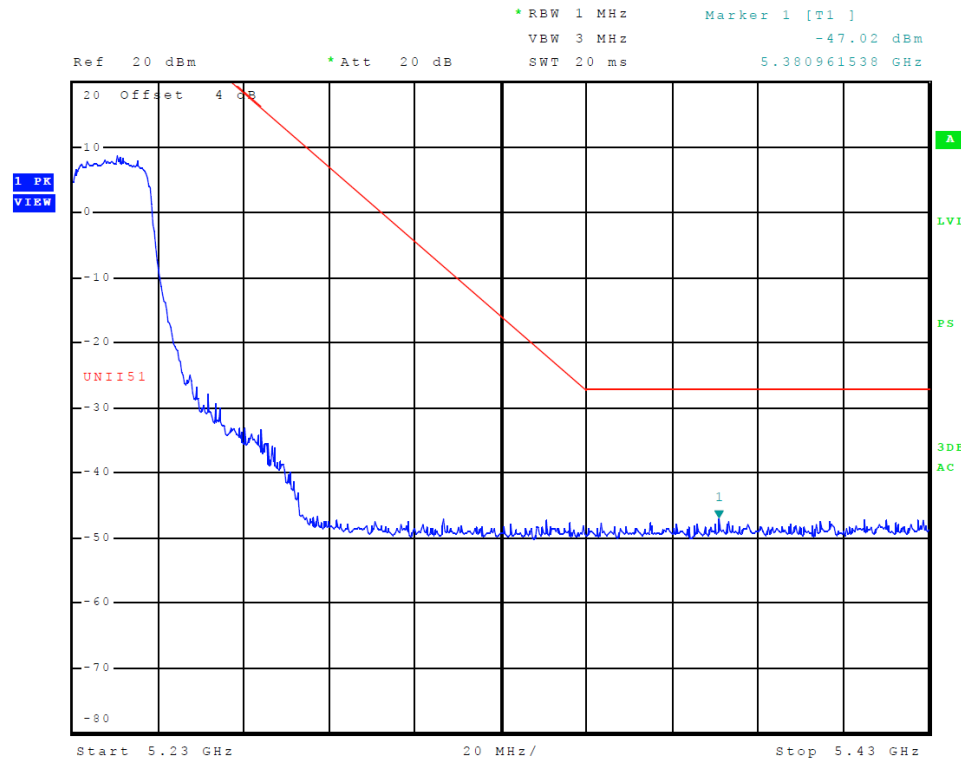

Figure 18 Plot of Transmitter High Band Edge (5150-5250 MHz Band, Chain 1, 802.11n40)

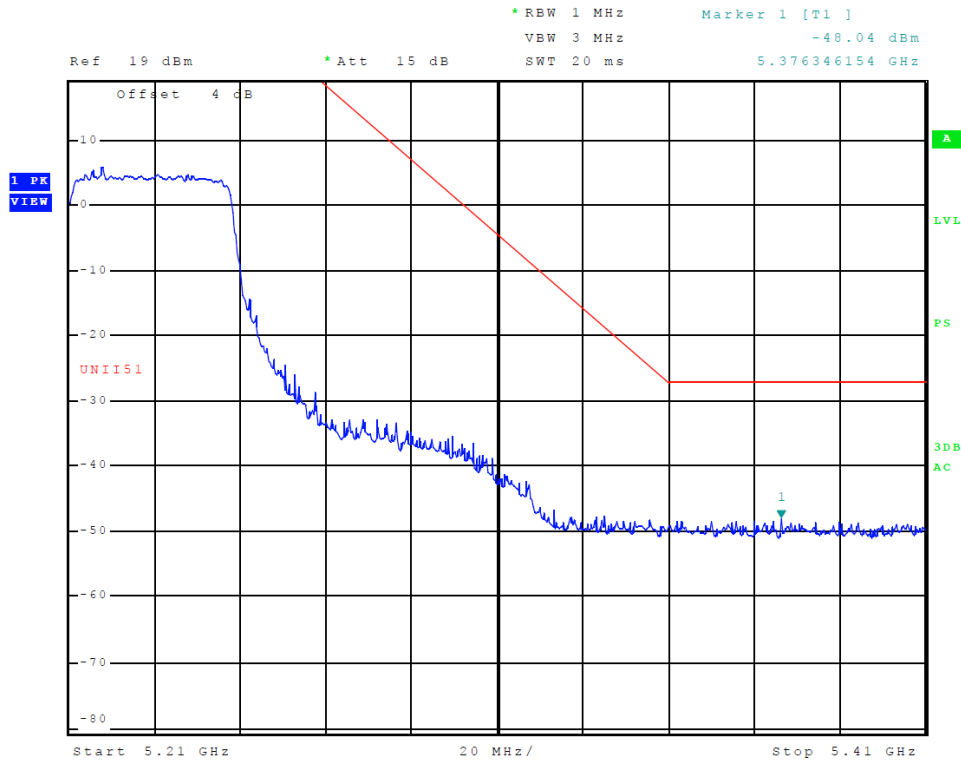

Figure 19 Plot of Transmitter High Band Edge (5150-5250 MHz Band, Chain 0, 802.11ac)

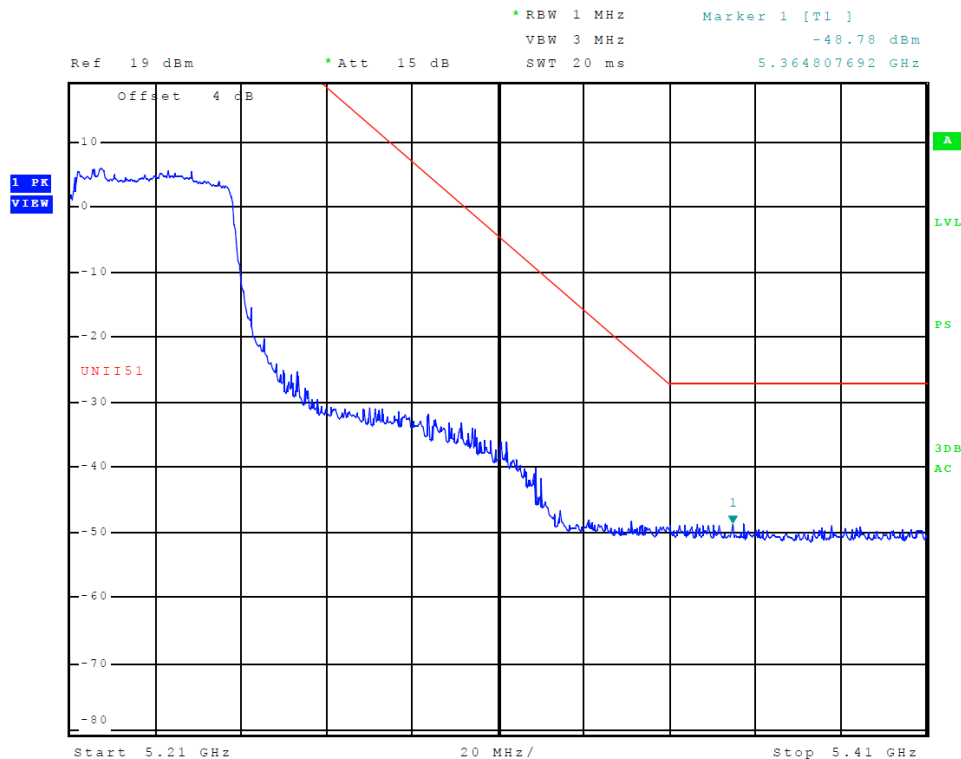

Figure 20 Plot of Transmitter High Band Edge (5150-5250 MHz Band, Chain 1, 802.11ac)

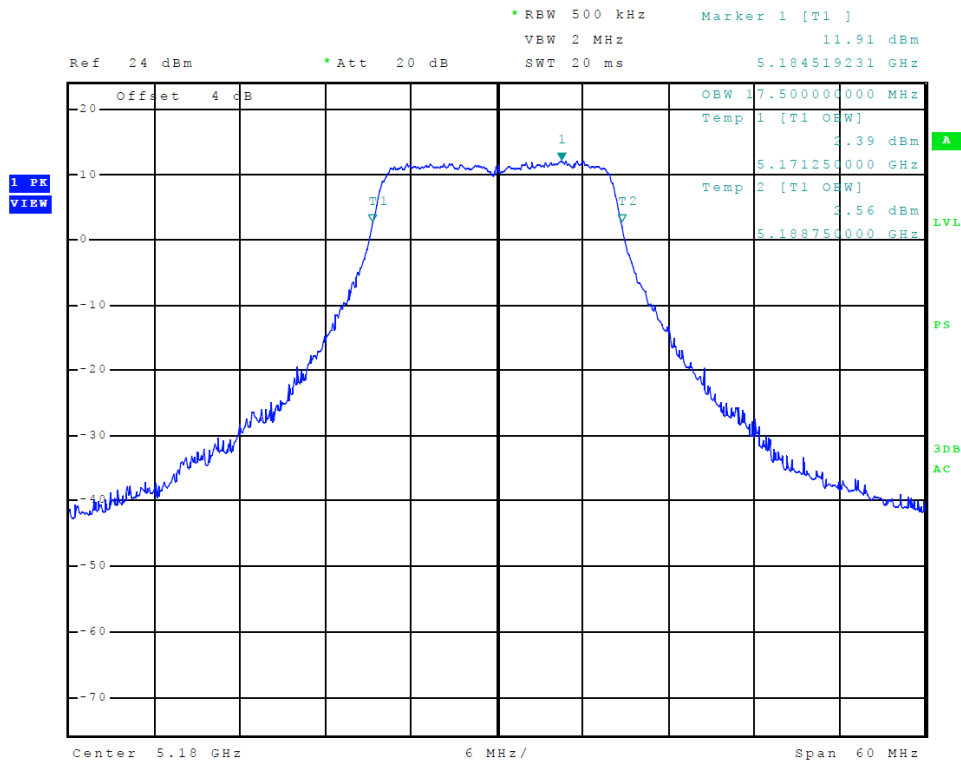

Figure 21 Plot of Transmitter Emissions (5150-5250 MHz Band, 802.11a, Chain 0, 99% OBW)

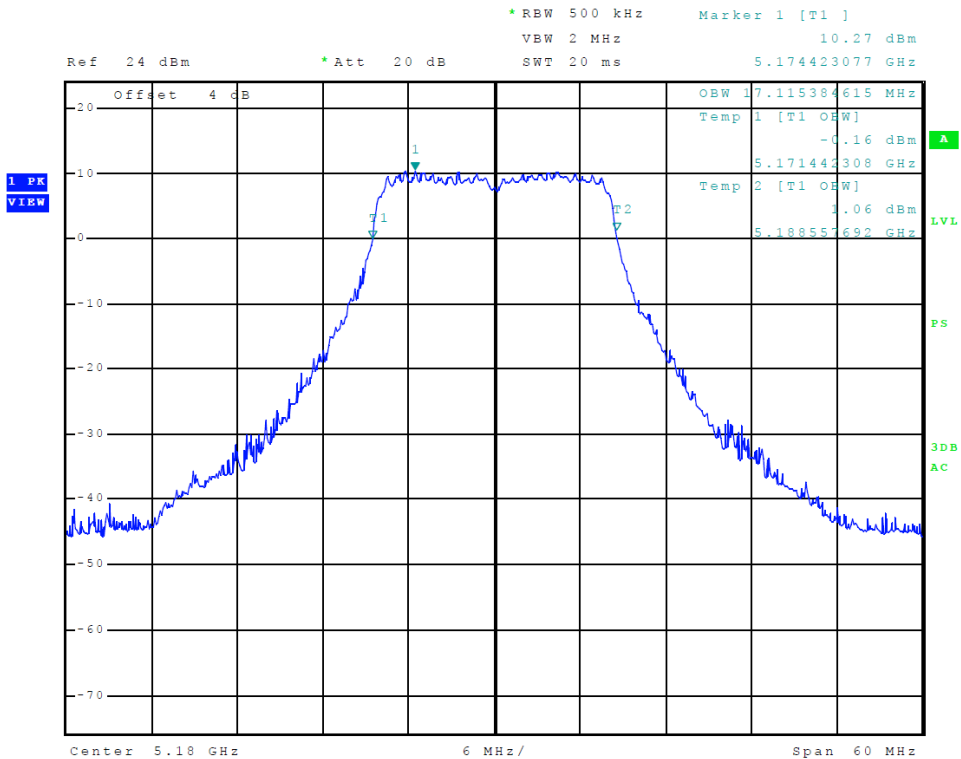

Figure 22 Plot of Transmitter Emissions (5150-5250 MHz Band, 802.11a, Chain 1, 99% OBW)

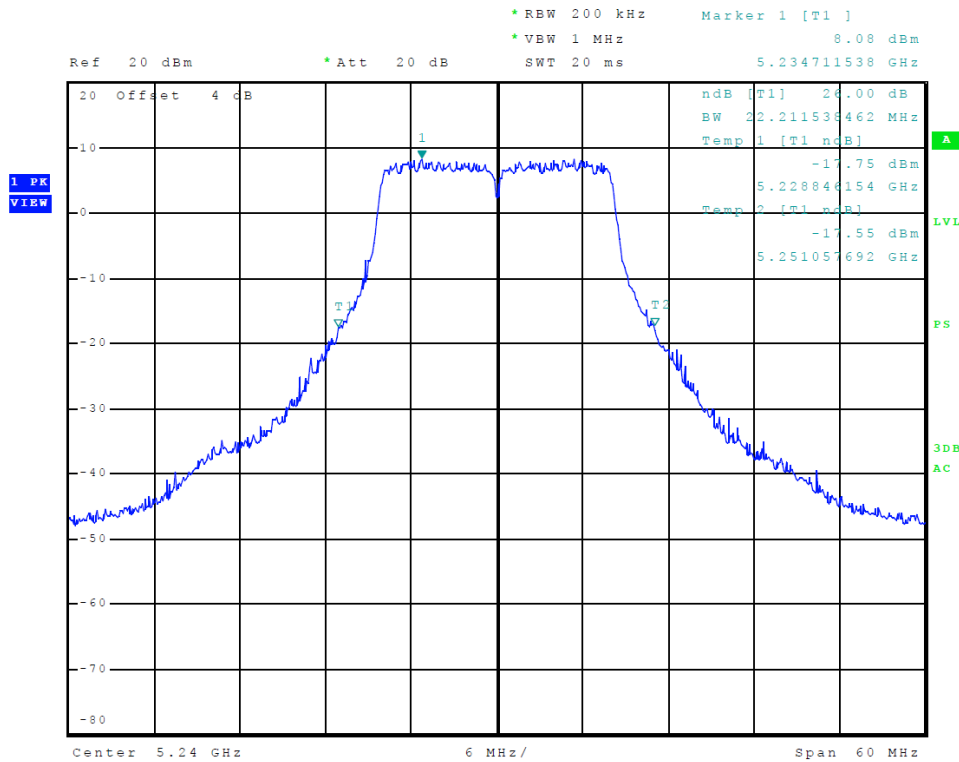

Figure 23 Plot of Transmitter Emissions (5150-5250 MHz Band, 802.11a, Chain 0, 26 dB OBW)

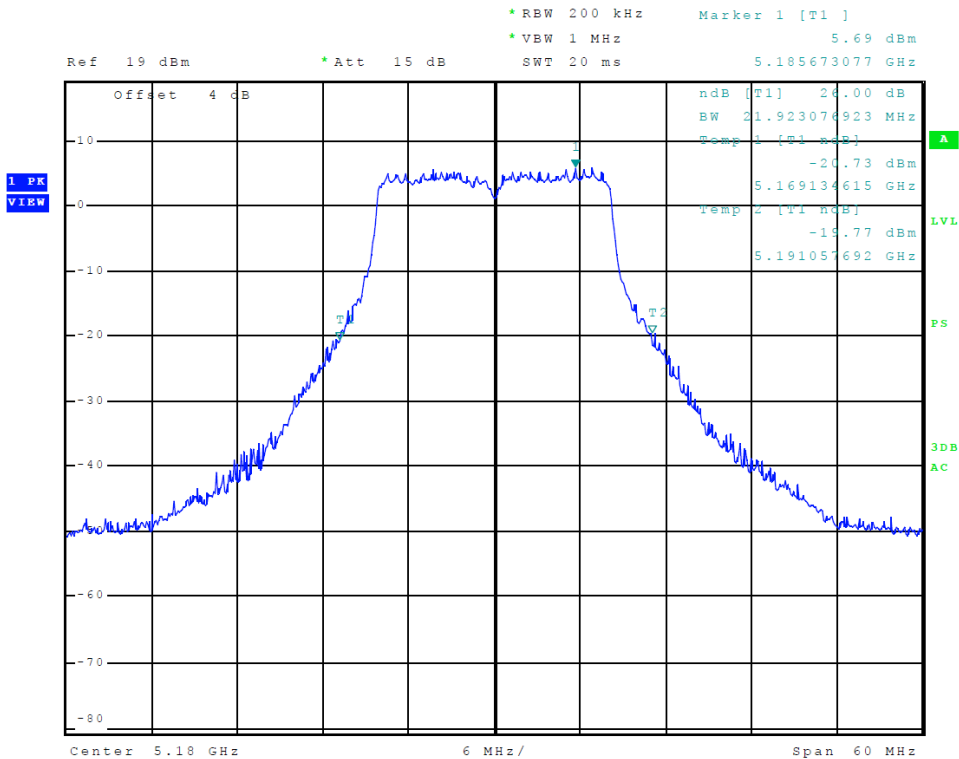

Figure 24 Plot of Transmitter Emissions (5150-5250 MHz Band, 802.11a, Chain 1, 26 dB OBW)

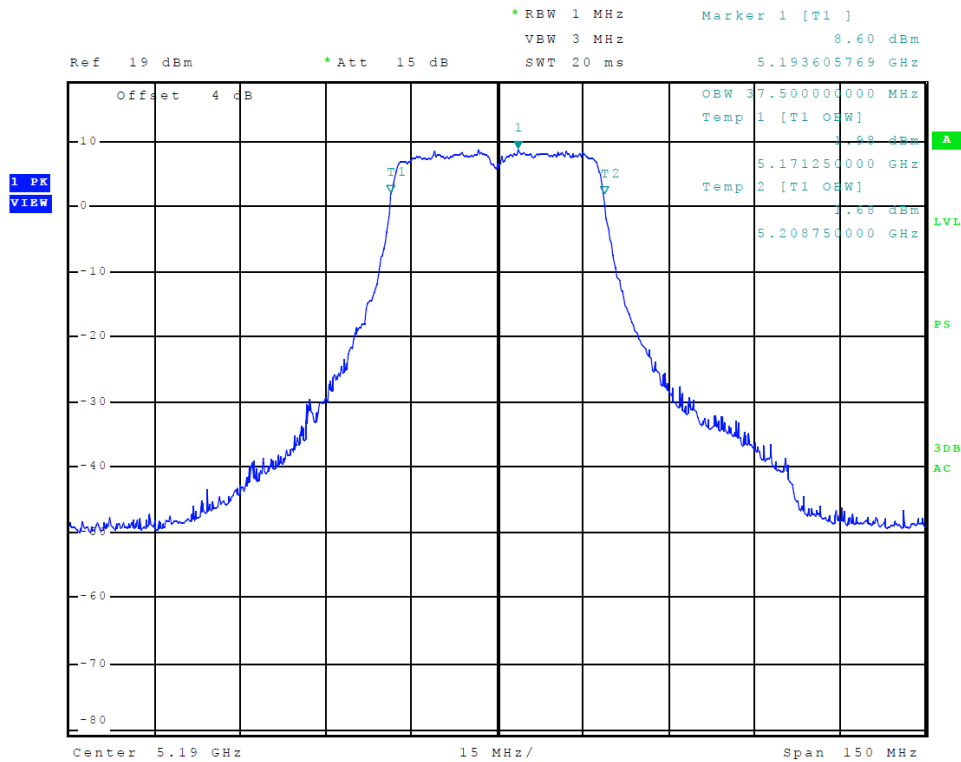

Figure 25 Plot of Transmitter Emissions (5150-5250 MHz Band, 802.11n40, Chain 0, 99% OBW)

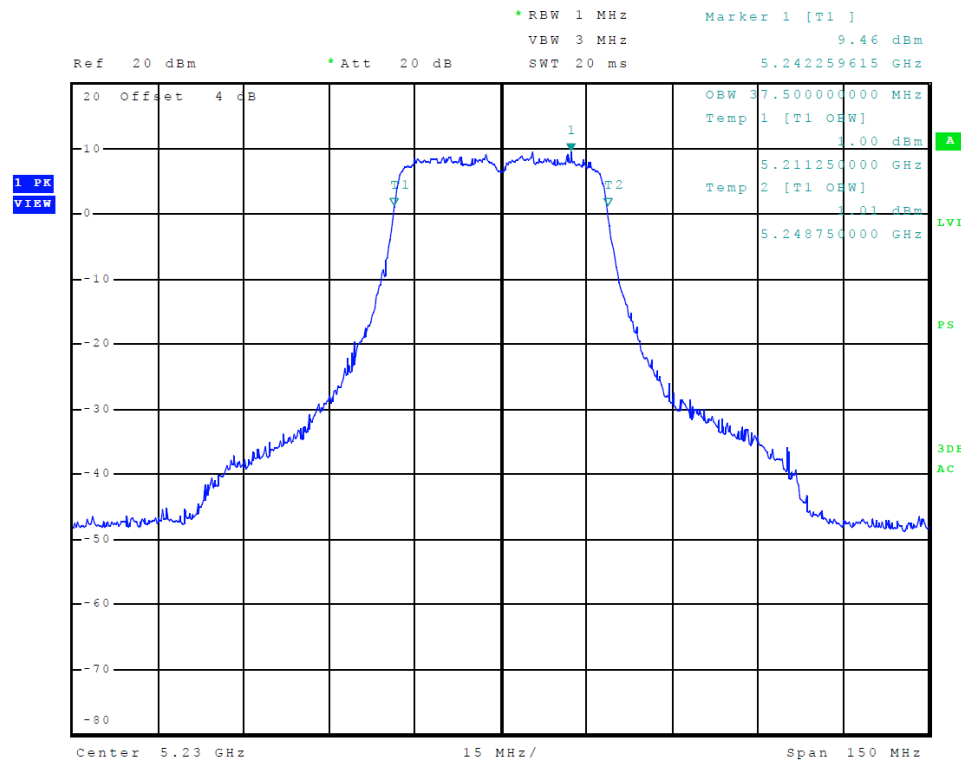

Figure 26 Plot of Transmitter Emissions (5150-5250 MHz Band, 802.11n40, Chain 1, 99% OBW)

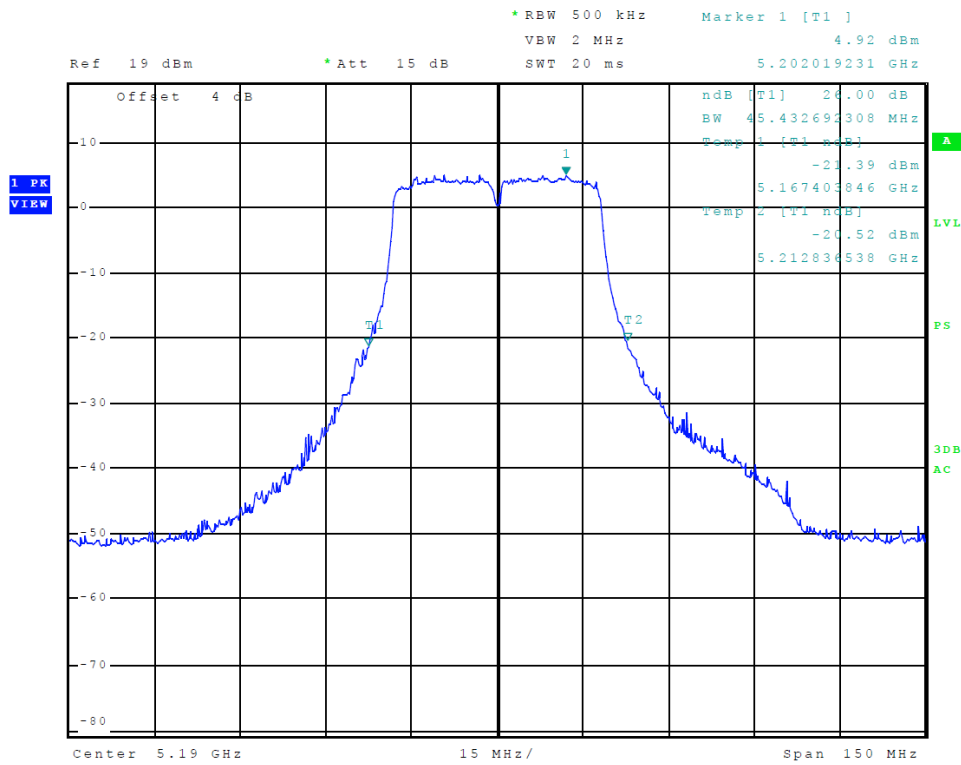

Figure 27 Plot of Transmitter Emissions (5150-5250 MHz Band, 802.11n40, Chain 0, 26 dB OBW)

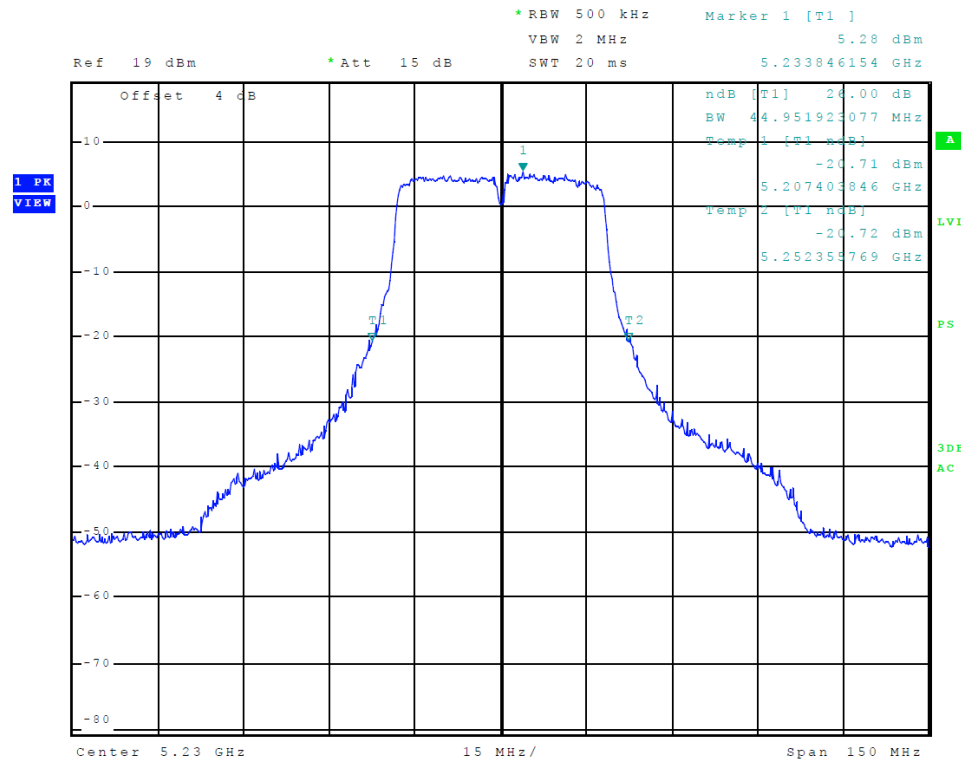

Figure 28 Plot of Transmitter Emissions (5150-5250 MHz Band, 802.11n40, Chain 1, 26 dB OBW)

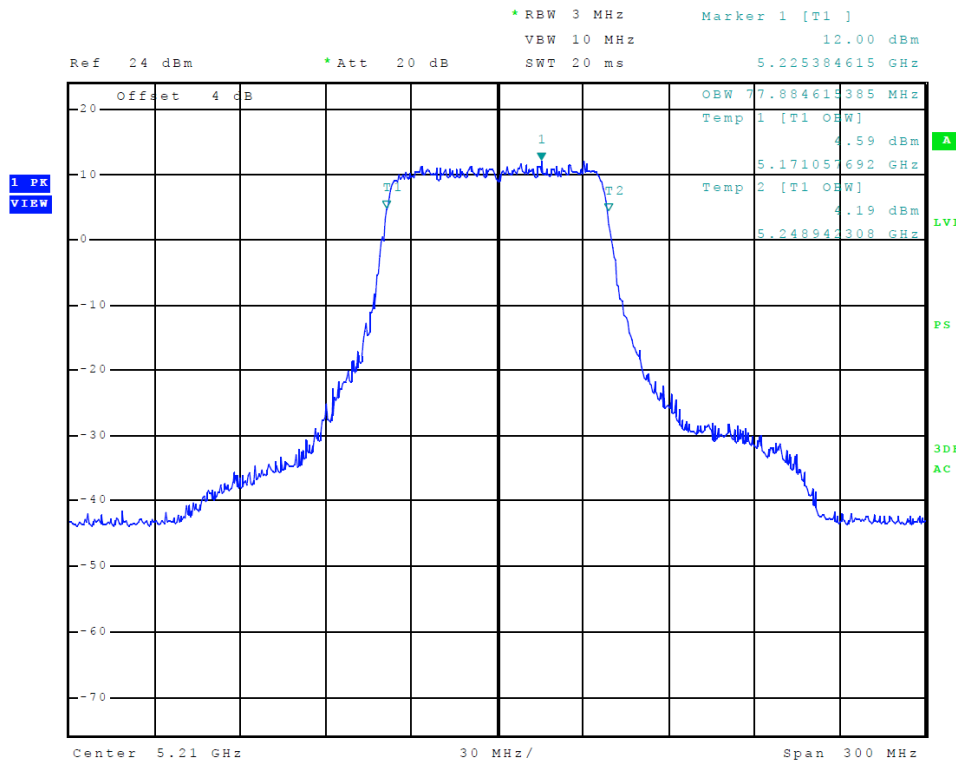

Figure 29 Plot of Transmitter Emissions (5150-5250 MHz Band, 802.11ac, Chain 0, 99% OBW)

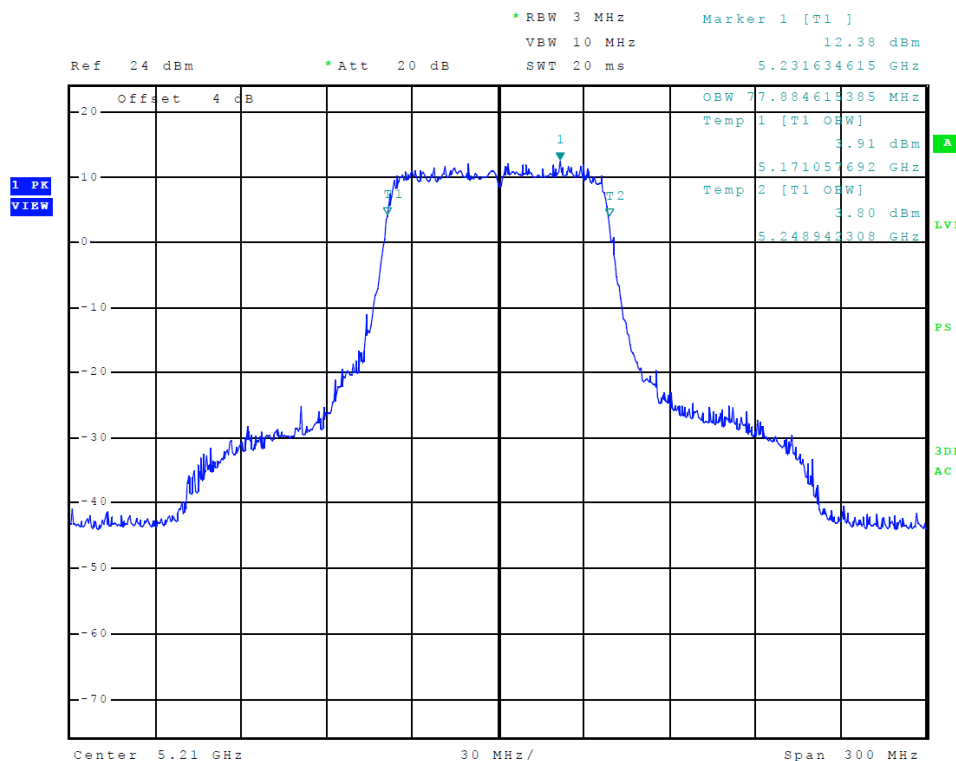

Figure 30 Plot of Transmitter Emissions (5150-5250 MHz Band, 802.11ac, Chain 1, 99% OBW)

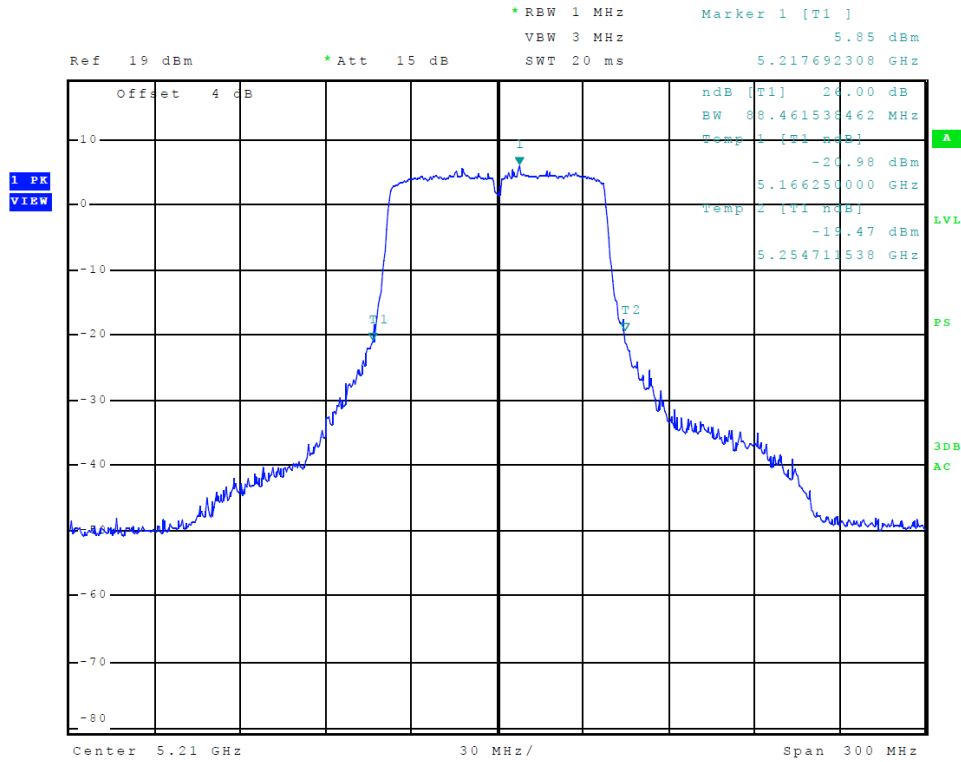

Figure 31 Plot of Transmitter Emissions (5150-5250 MHz Band, 802.11ac, Chain 0, 26 dB OBW)

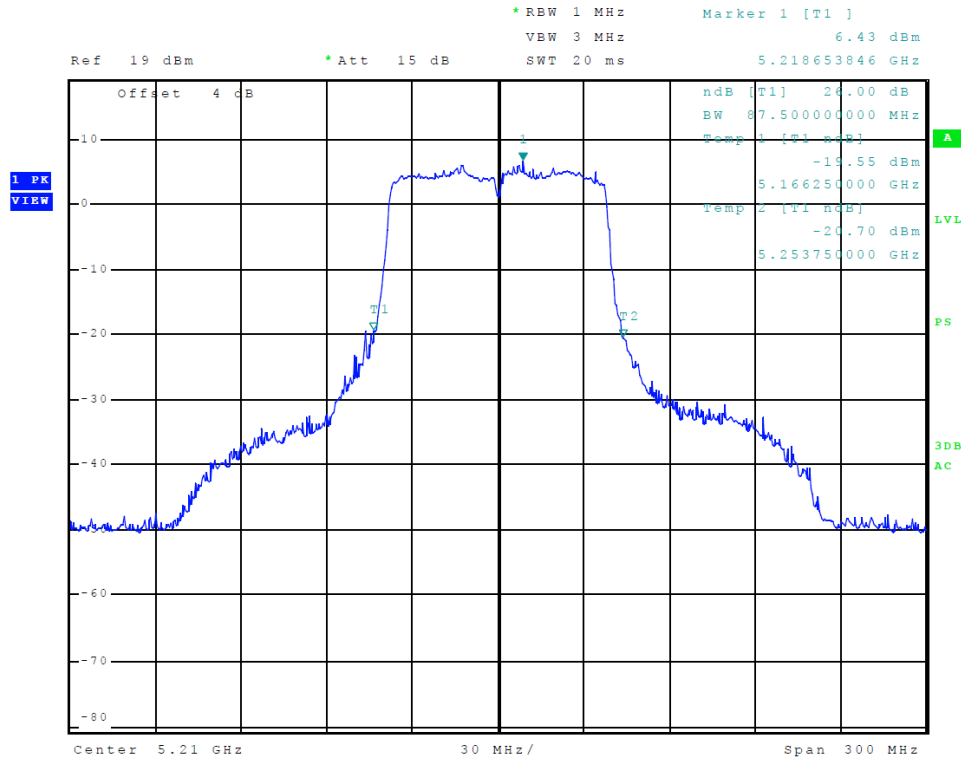

Figure 32 Plot of Transmitter Emissions (5150-5250 MHz Band, 802.11ac, Chain 1, 26 dB OBW)

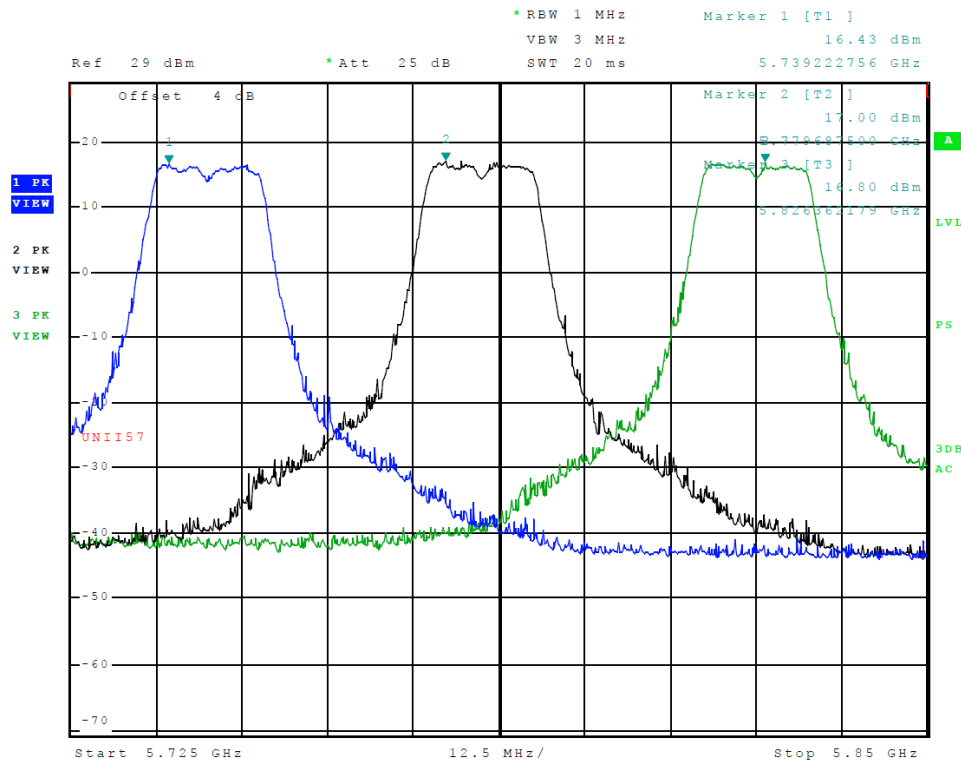

Figure 33 Plot of Transmitter Emissions (Across 5725-5850 MHz Band, Chain 0, 802.11a)

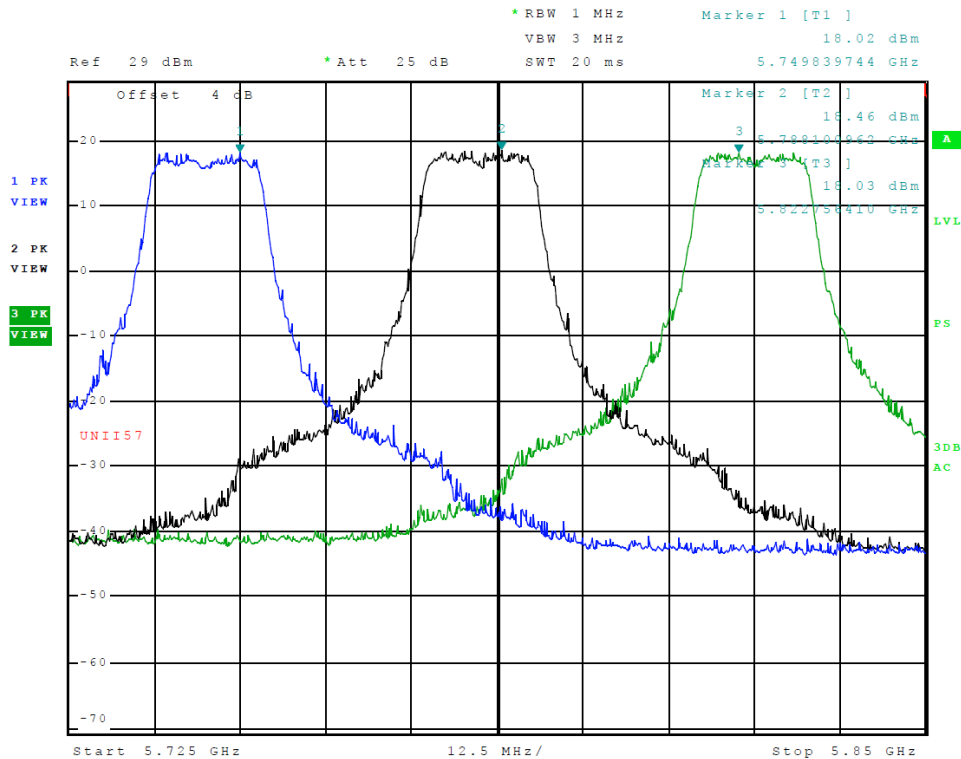

Figure 34 Plot of Transmitter Emissions (Across 5725-5850 MHz Band, Chain 1, 802.11a)

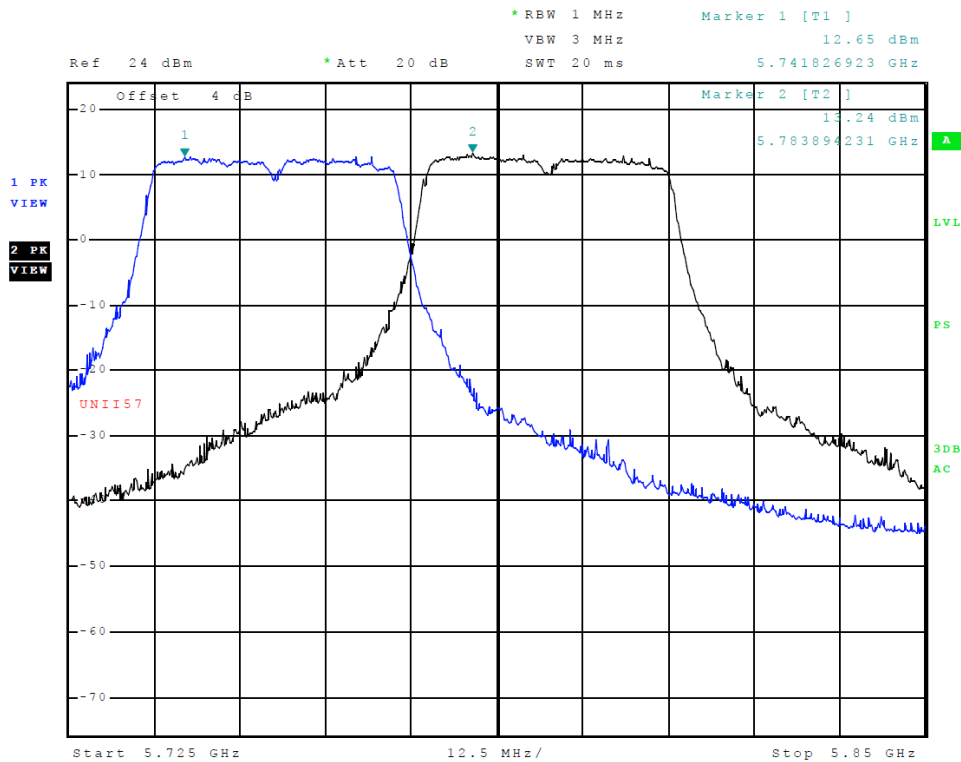

Figure 35 Plot of Transmitter Emissions (Across 5725-5850 MHz Band, Chain 0, 802.11n40)

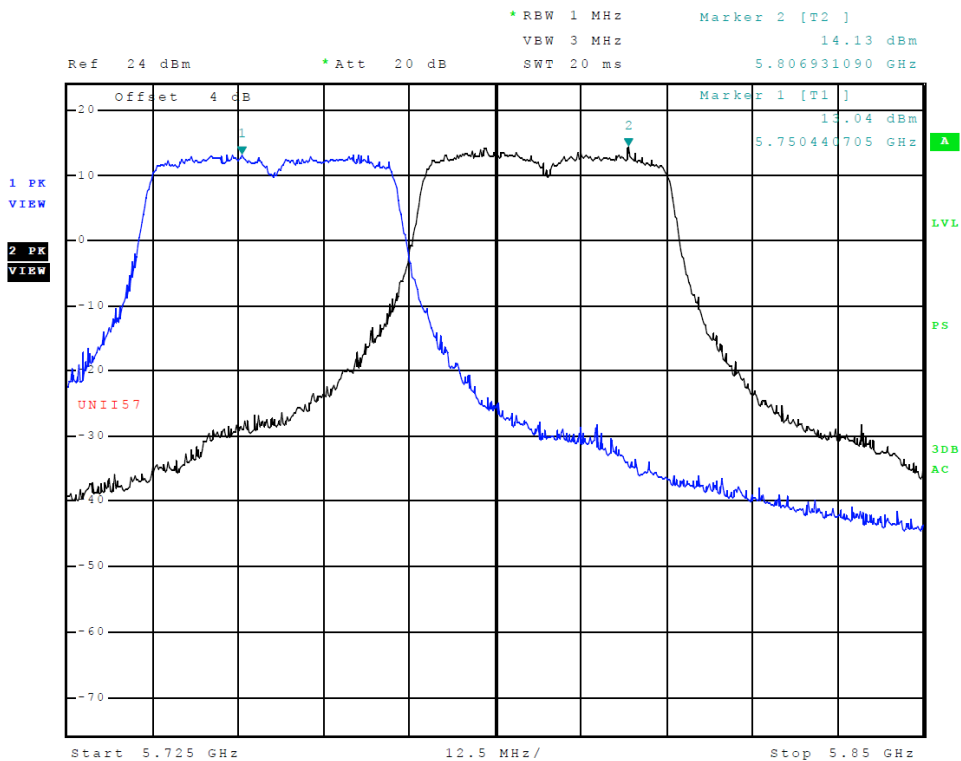

Figure 36 Plot of Transmitter Emissions (Across 5725-5850 MHz Band, Chain 1, 802.11n40)

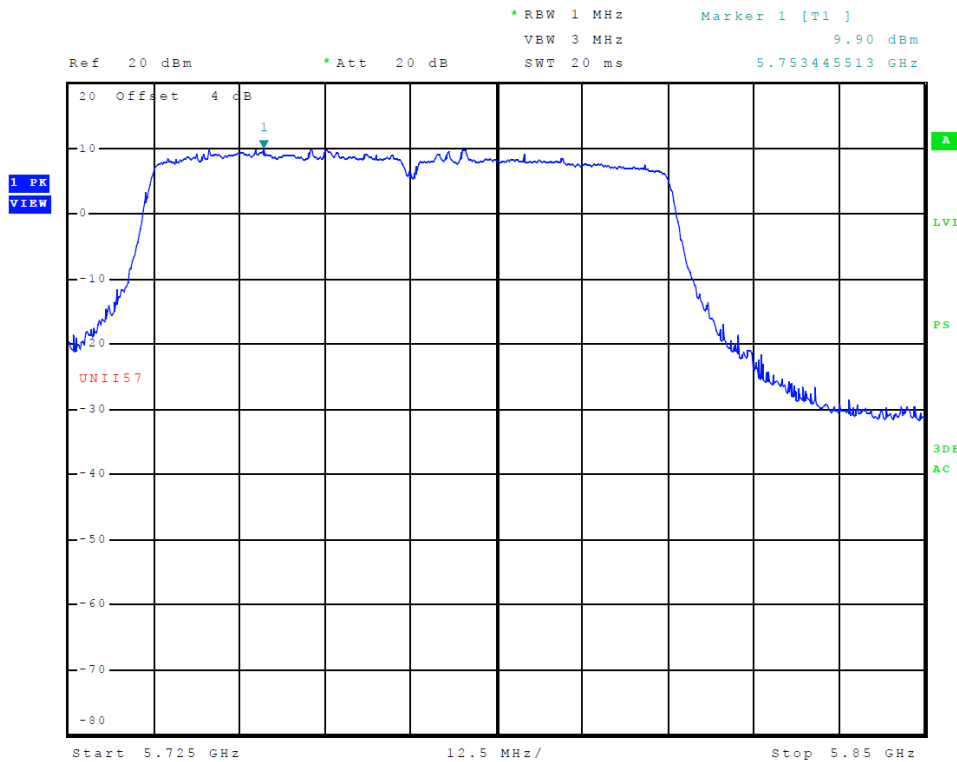

Figure 37 Plot of Transmitter Emissions (Across 5725-5850 MHz Band, Chain 0, 802.11ac)

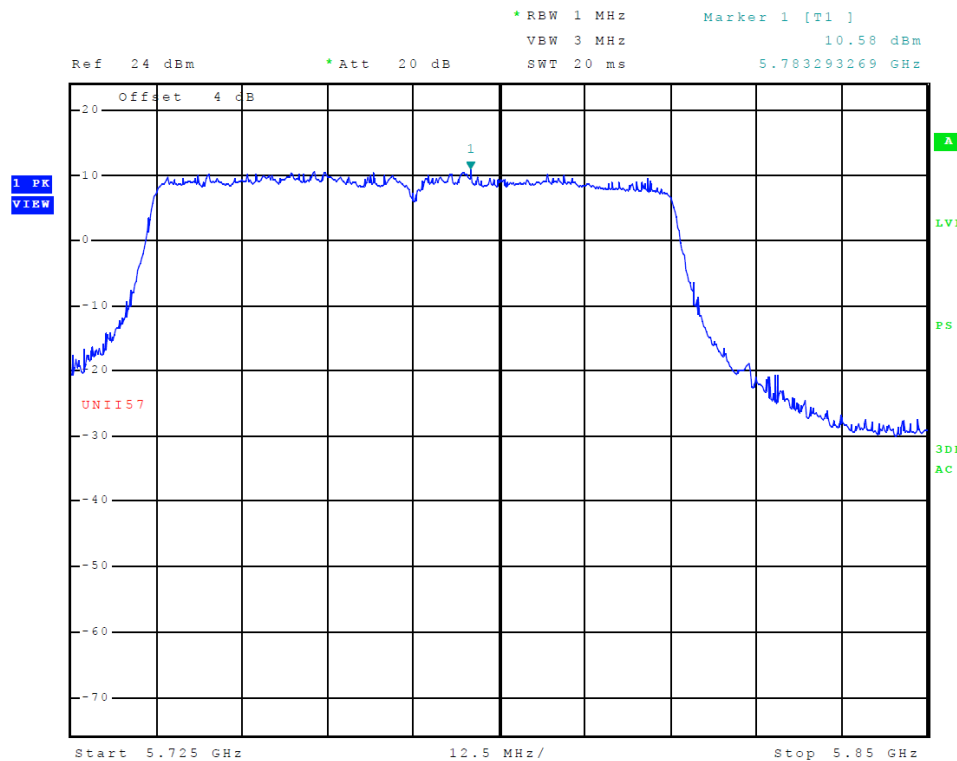

Figure 38 Plot of Transmitter Emissions (Across 5725-5850 MHz Band, Chain 1, 802.11ac)

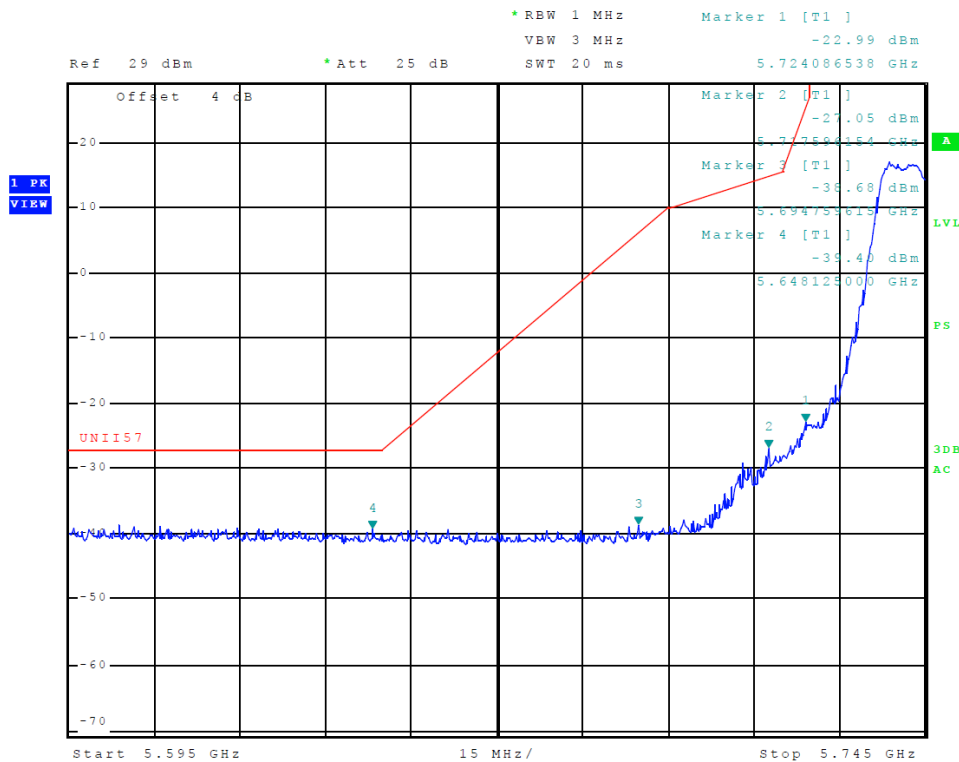

Figure 39 Plot of Transmitter Low Band Edge (5725-5850 MHz Band, Chain 0, 802.11a)

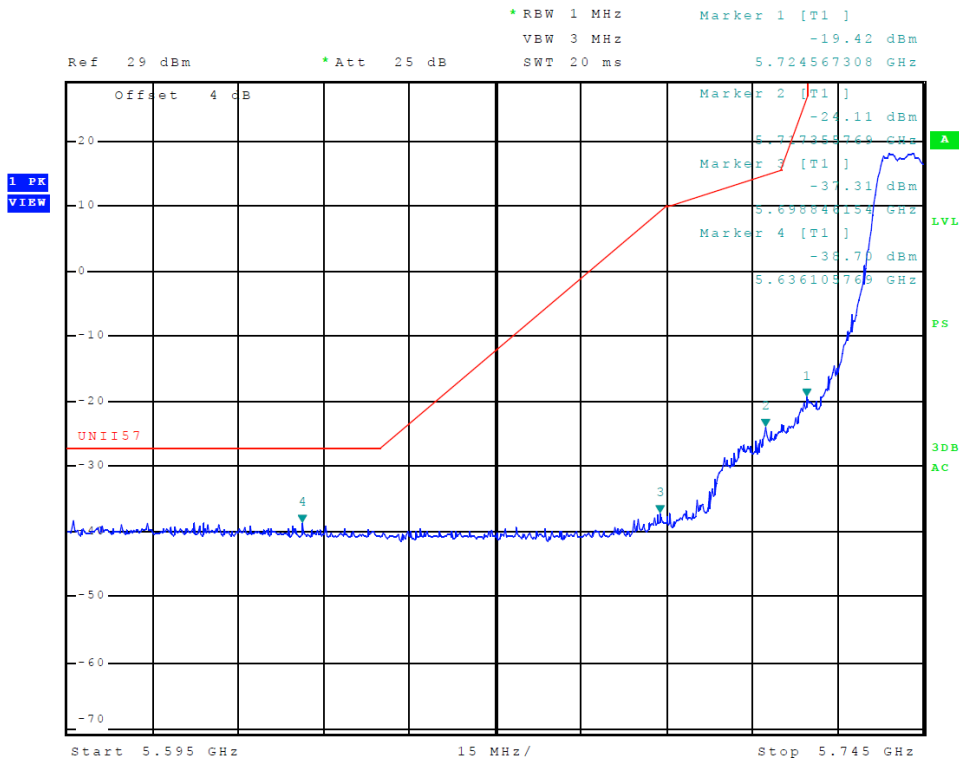

Figure 40 Plot of Transmitter Low Band Edge (5725-5850 MHz Band, Chain 1, 802.11a)

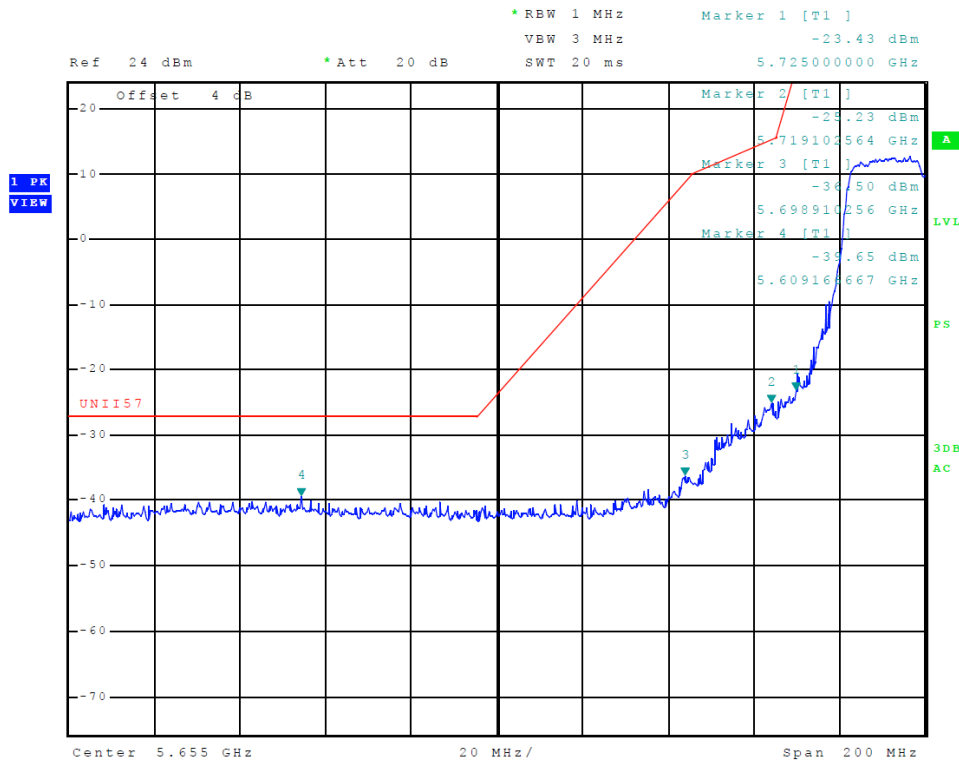

Figure 41 Plot of Transmitter Low Band Edge (5725-5850 MHz Band, Chain 0, 802.11n40)

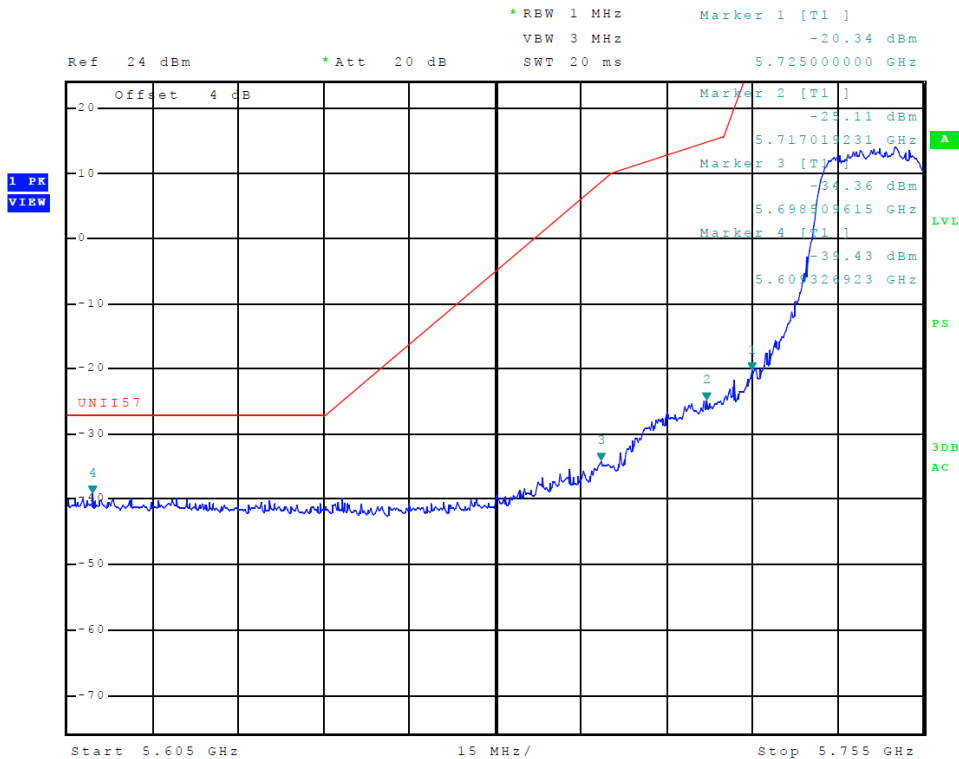

Figure 42 Plot of Transmitter Low Band Edge (5725-5850 MHz Band, Chain 1, 802.11n40)

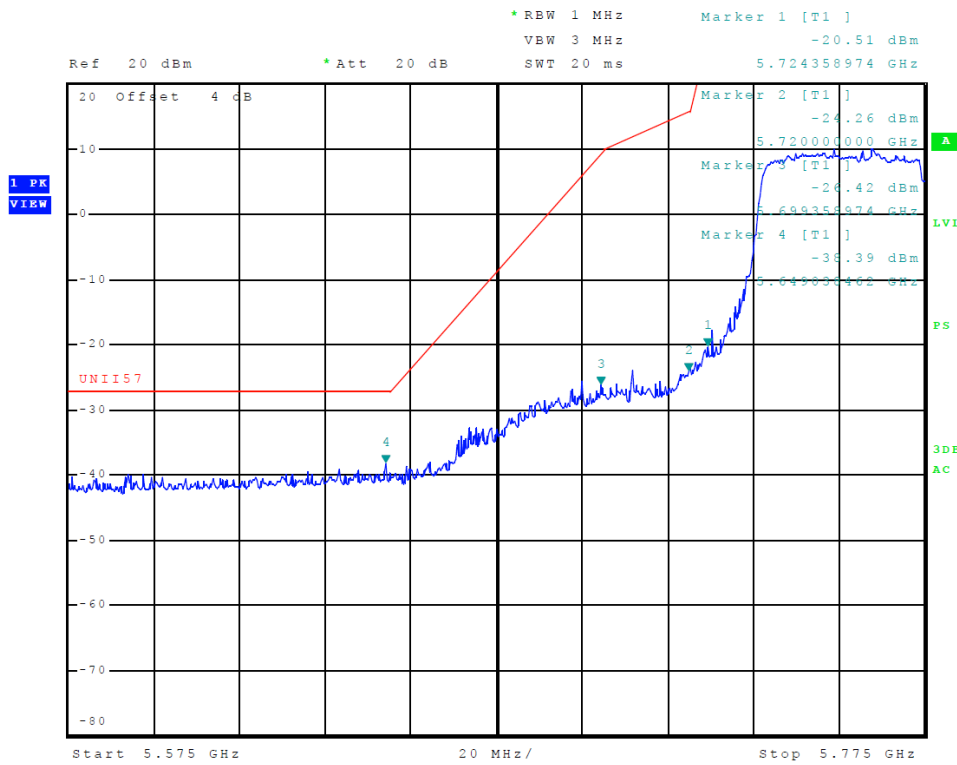

Figure 43 Plot of Transmitter Low Band Edge (5725-5850 MHz Band, Chain 0, 802.11ac)

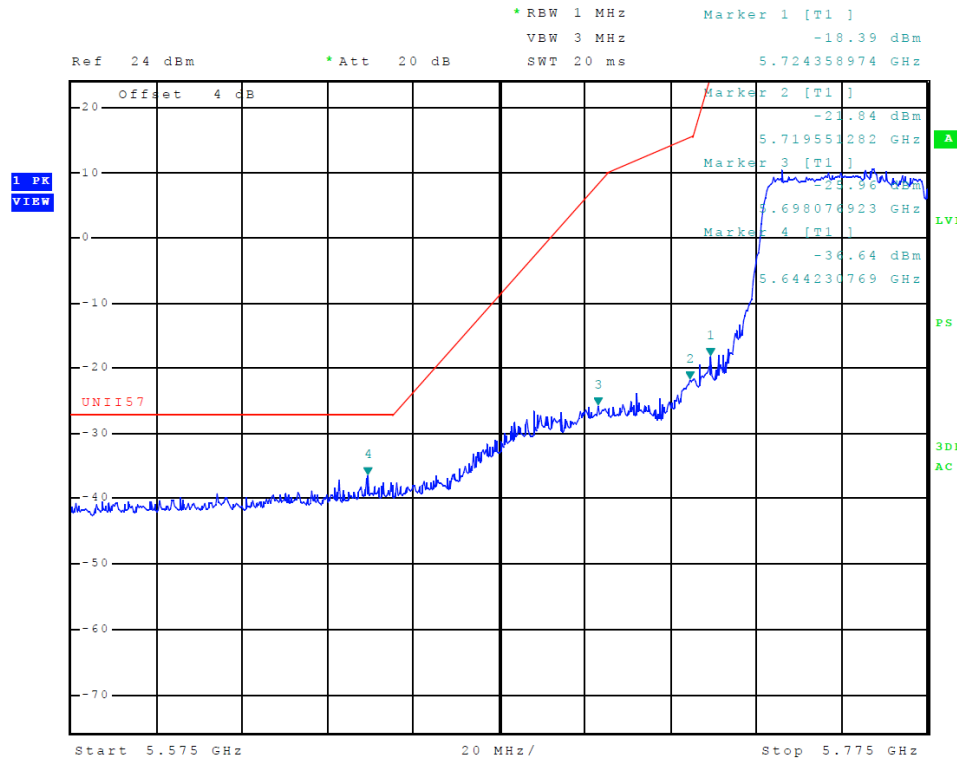

Figure 44 Plot of Transmitter Low Band Edge (5725-5850 MHz Band, Chain 1, 802.11ac)

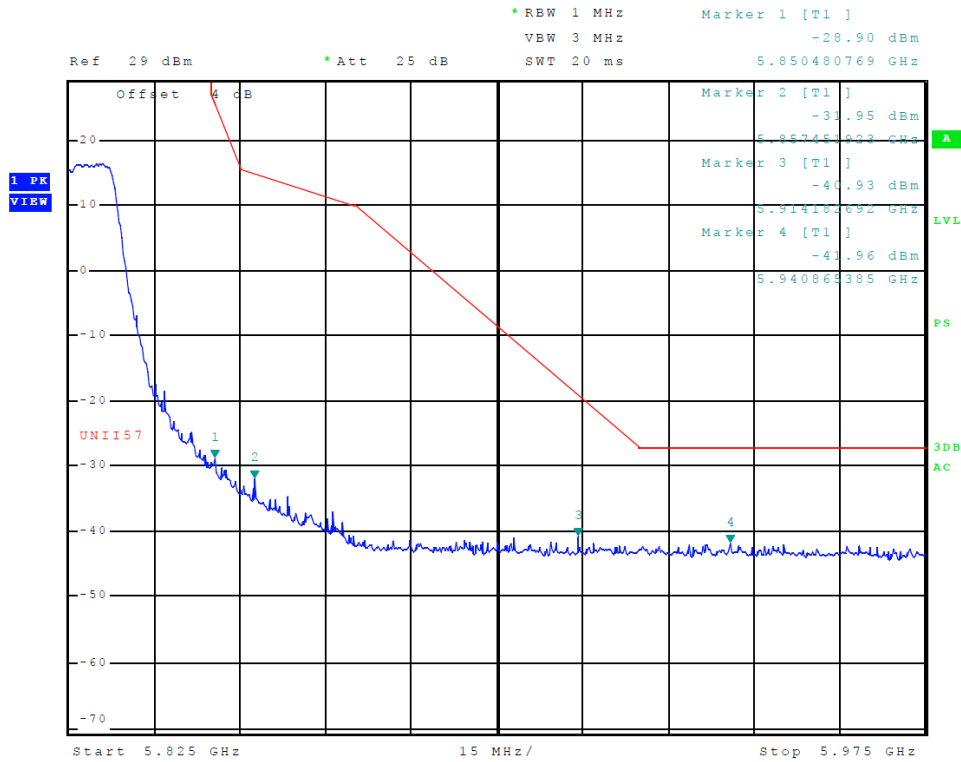

Figure 45 Plot of Transmitter High Band Edge (5725-5850 MHz Band, Chain 0, 802.11a)

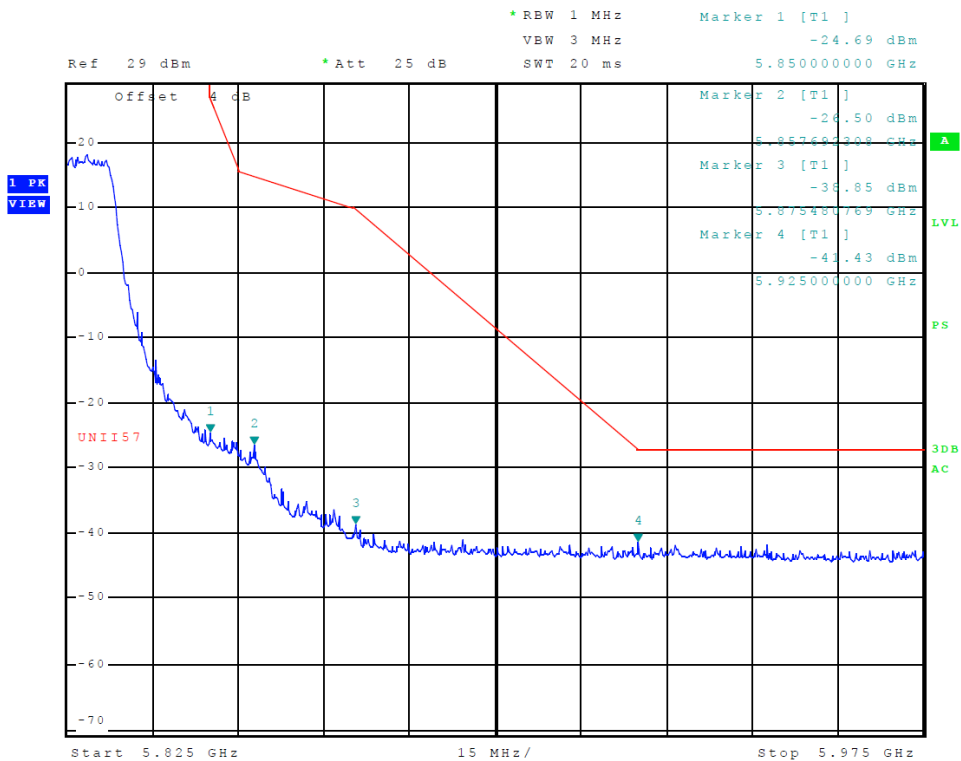

Figure 46 Plot of Transmitter High Band Edge (5725-5850 MHz Band, Chain 1, 802.11a)

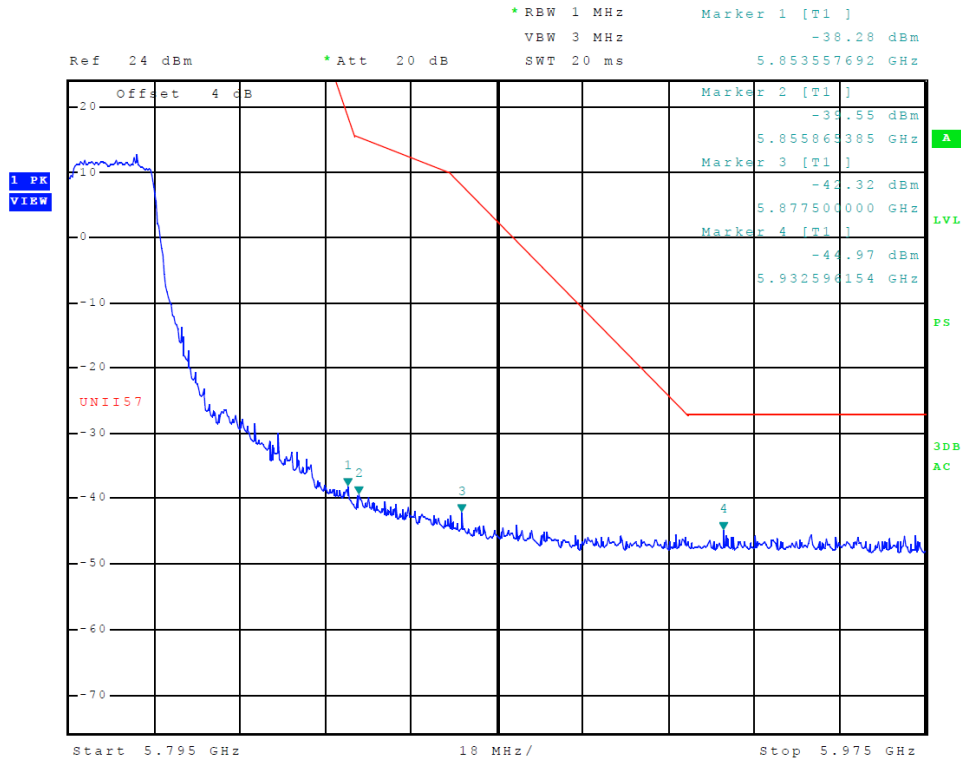

Figure 47 Plot of Transmitter High Band Edge (5725-5850 MHz Band, Chain 0, 802.11n40)

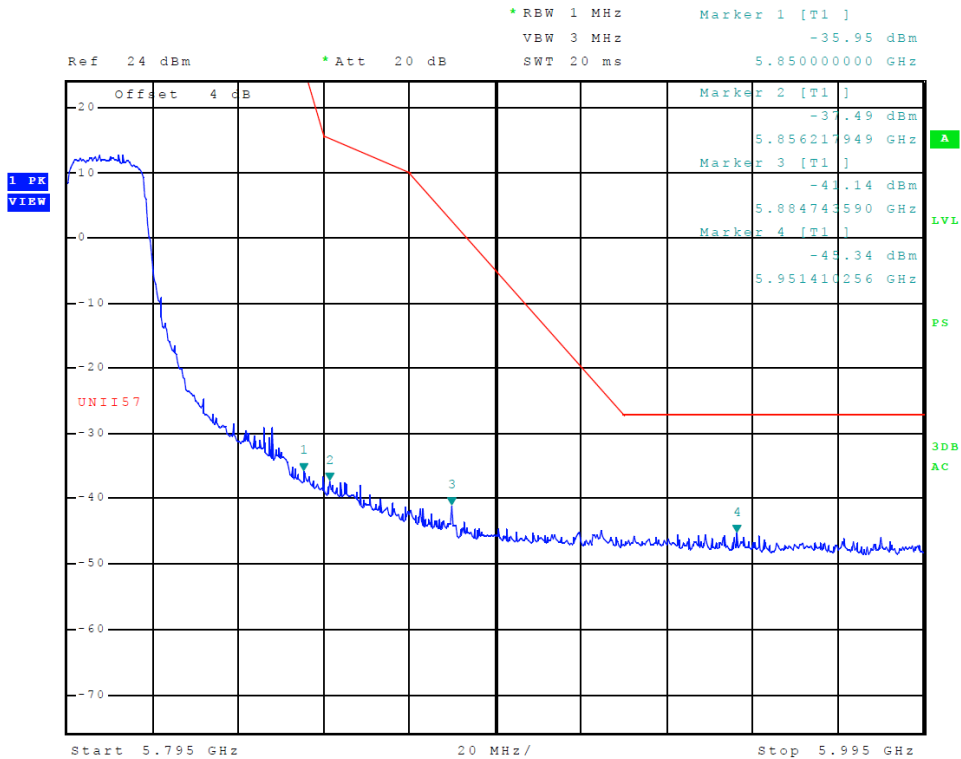

Figure 48 Plot of Transmitter High Band Edge (5725-5850 MHz Band, Chain 1, 802.11n40)

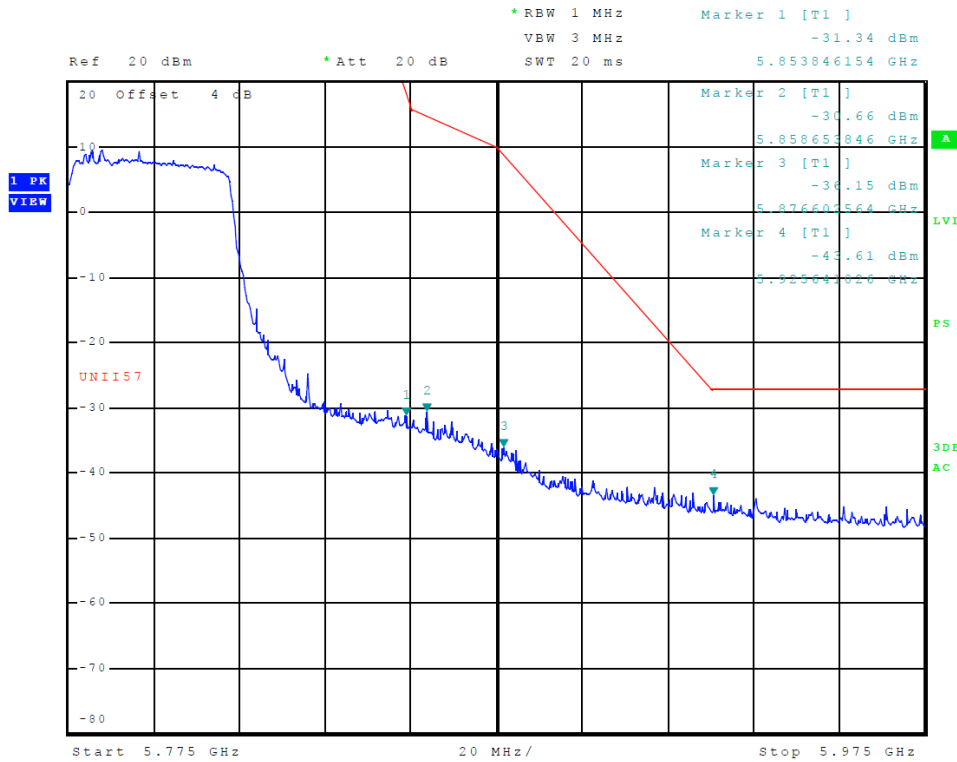

Figure 49 Plot of Transmitter High Band Edge (5725-5850 MHz Band, Chain 0, 802.11ac)

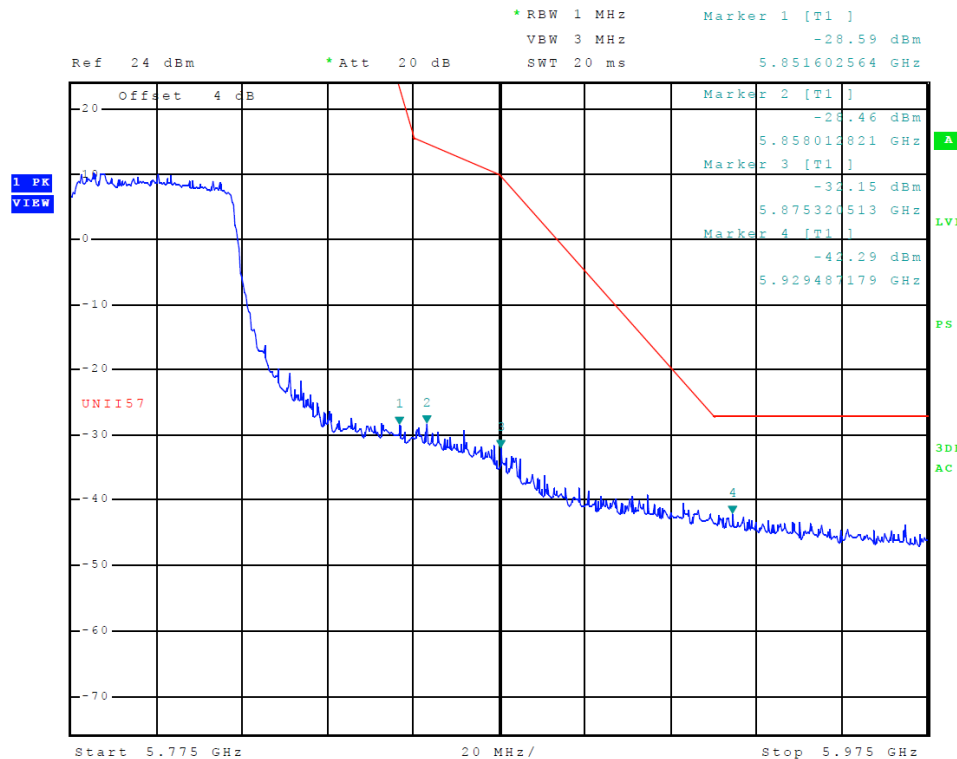

Figure 50 Plot of Transmitter High Band Edge (5725-5850 MHz Band, Chain 1, 802.11ac)

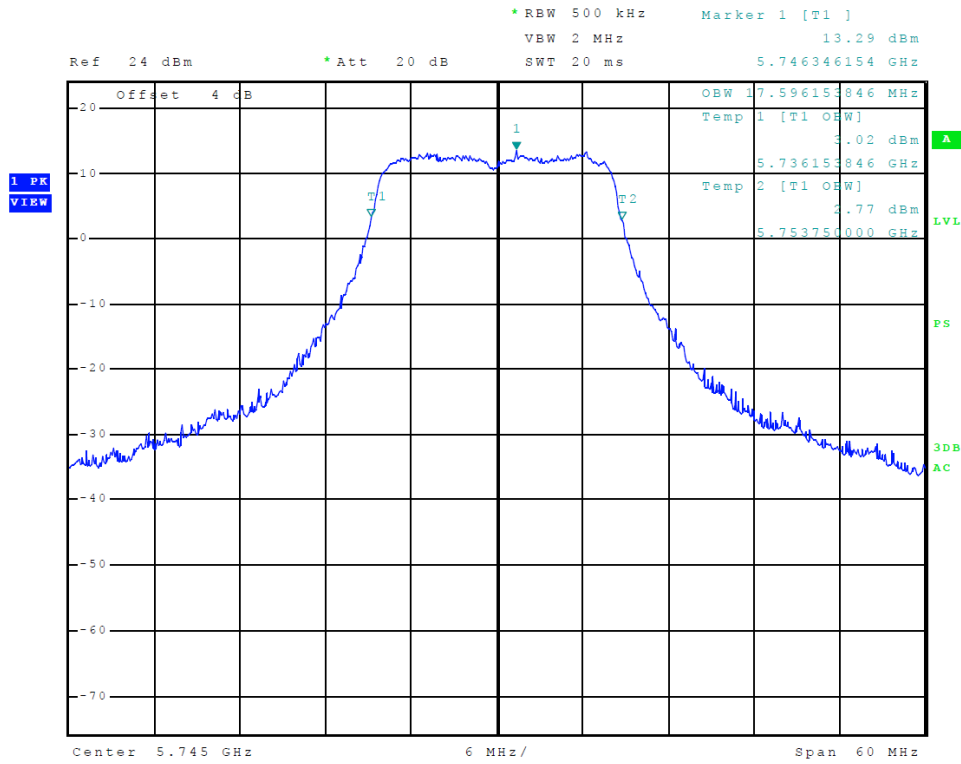

Figure 51 Plot of Transmitter Emissions (5725-5850 MHz Band, 802.11a, Chain 0, 99% OBW)

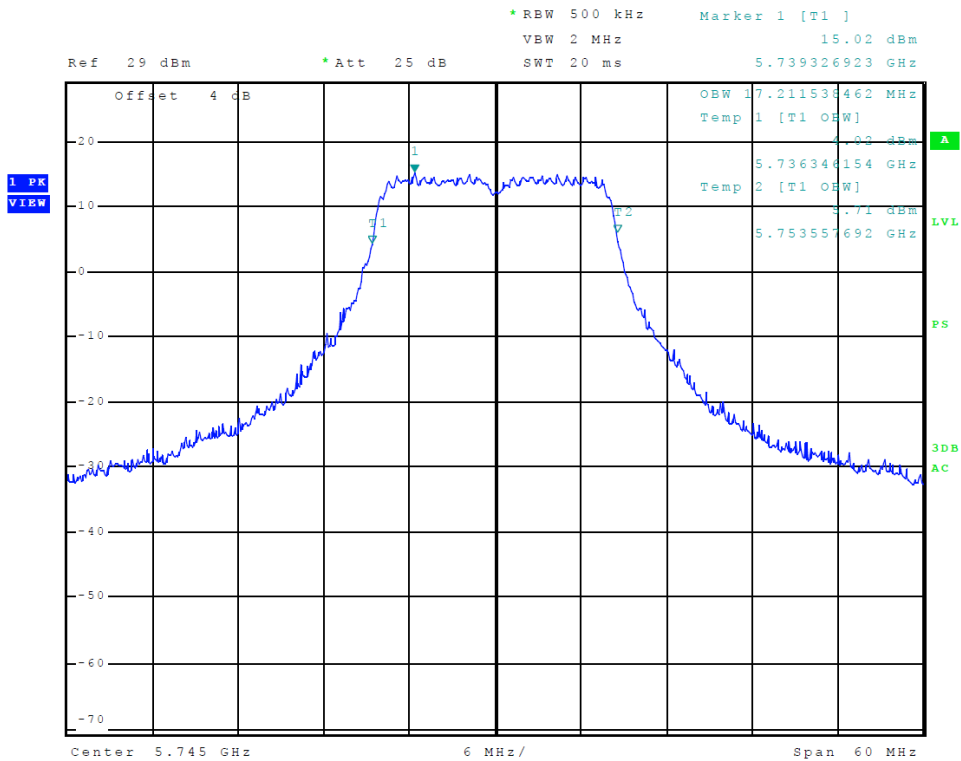

Figure 52 Plot of Transmitter Emissions (5725-5850 MHz Band, 802.11a, Chain 1, 99% OBW)

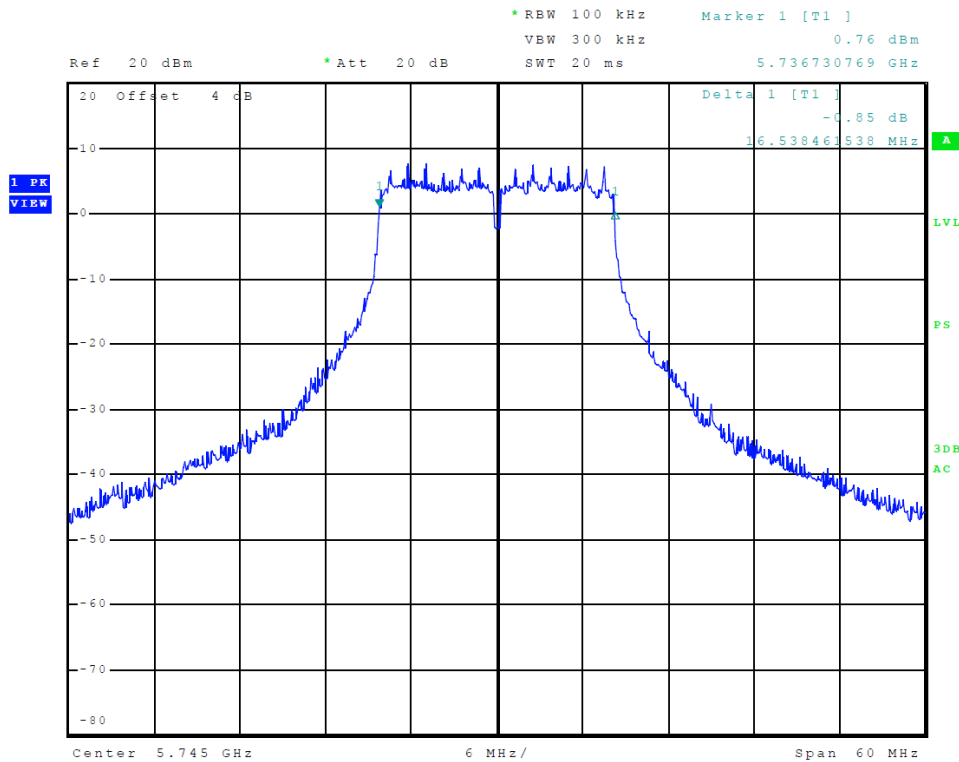

Figure 53 Plot of Transmitter Emissions (5725-5850 MHz Band, 802.11a, Chain 0, 6-dB OBW)

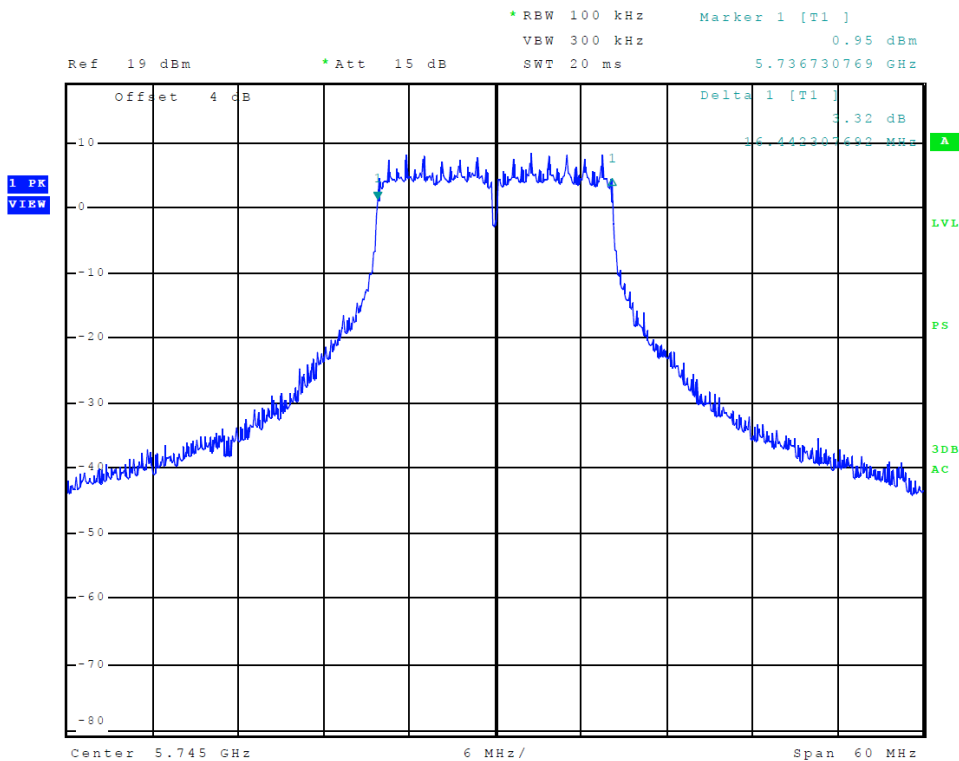

Figure 54 Plot of Transmitter Emissions (5725-5850 MHz Band, 802.11a, Chain 1, 6-dB OBW)

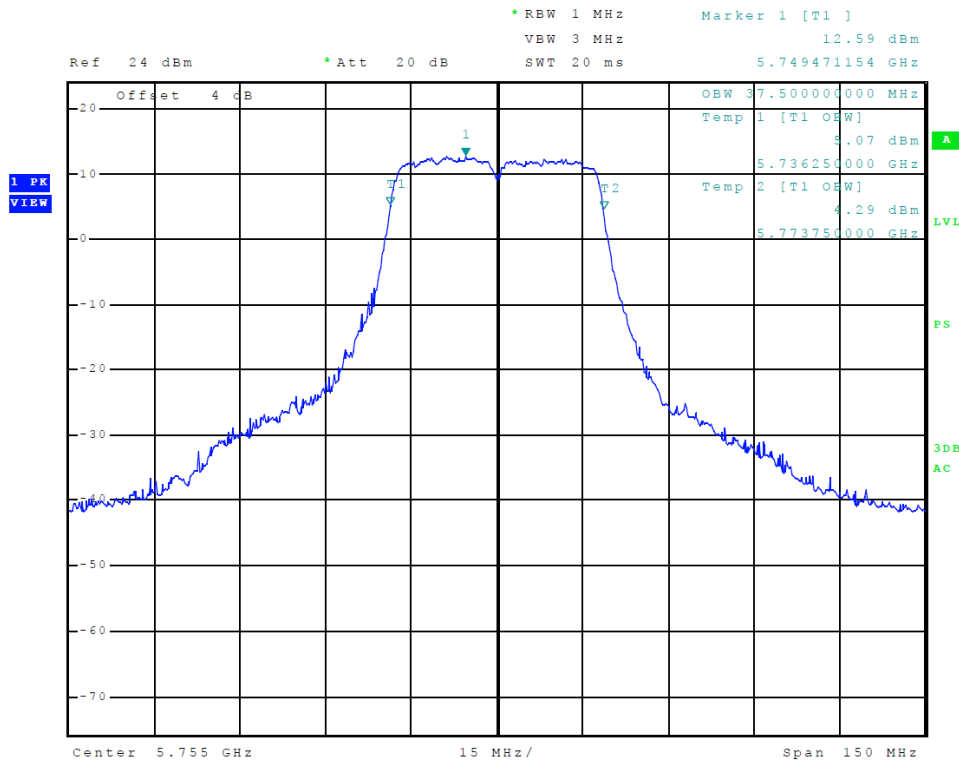

Figure 55 Plot of Transmitter Emissions (5725-5850 MHz Band, 802.11n40, Chain 0, 99% OBW)

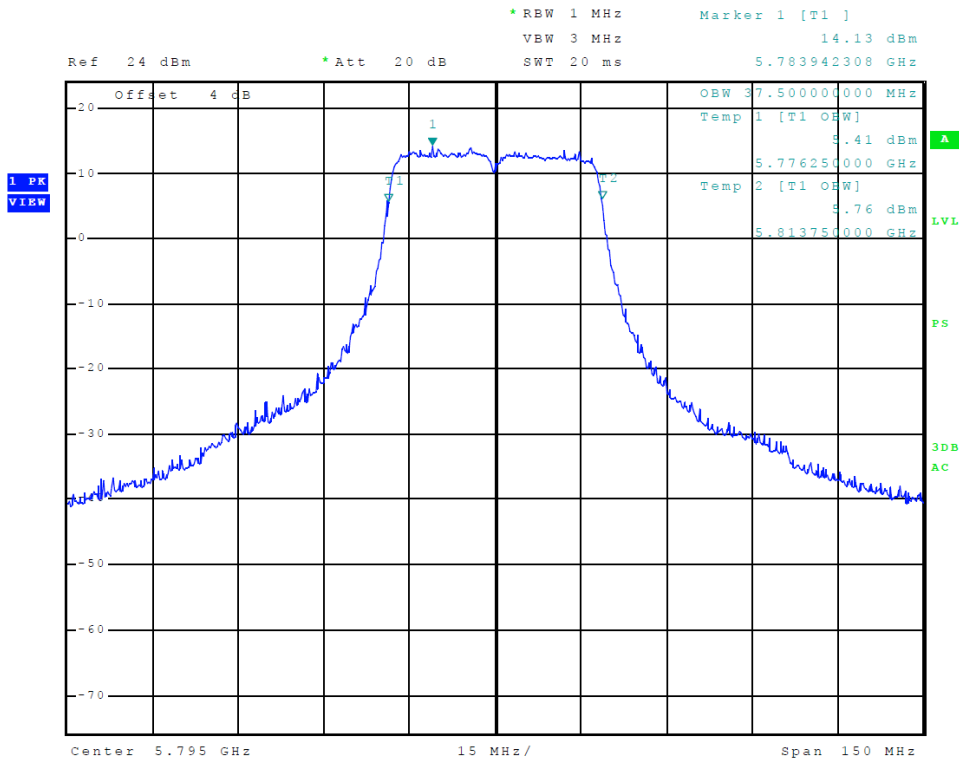

Figure 56 Plot of Transmitter Emissions (5725-5850 MHz Band, 802.11n40, Chain 1, 99% OBW)

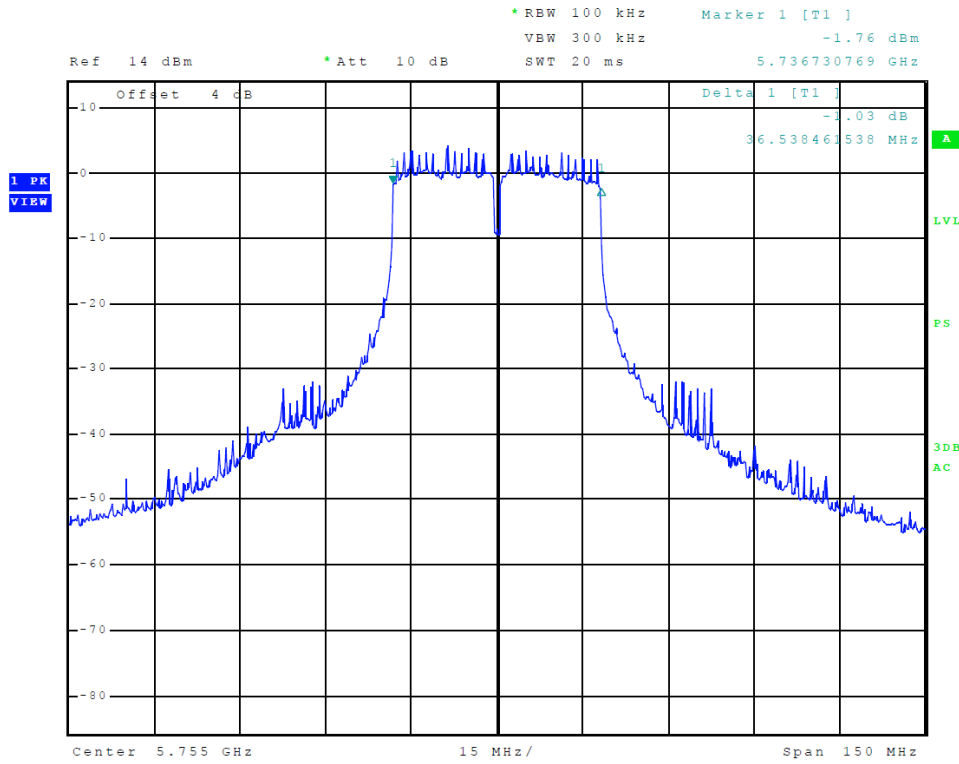

Figure 57 Plot of Transmitter Emissions (5725-5850 MHz Band, 802.11n40, Chain 0, 6-dB OBW)

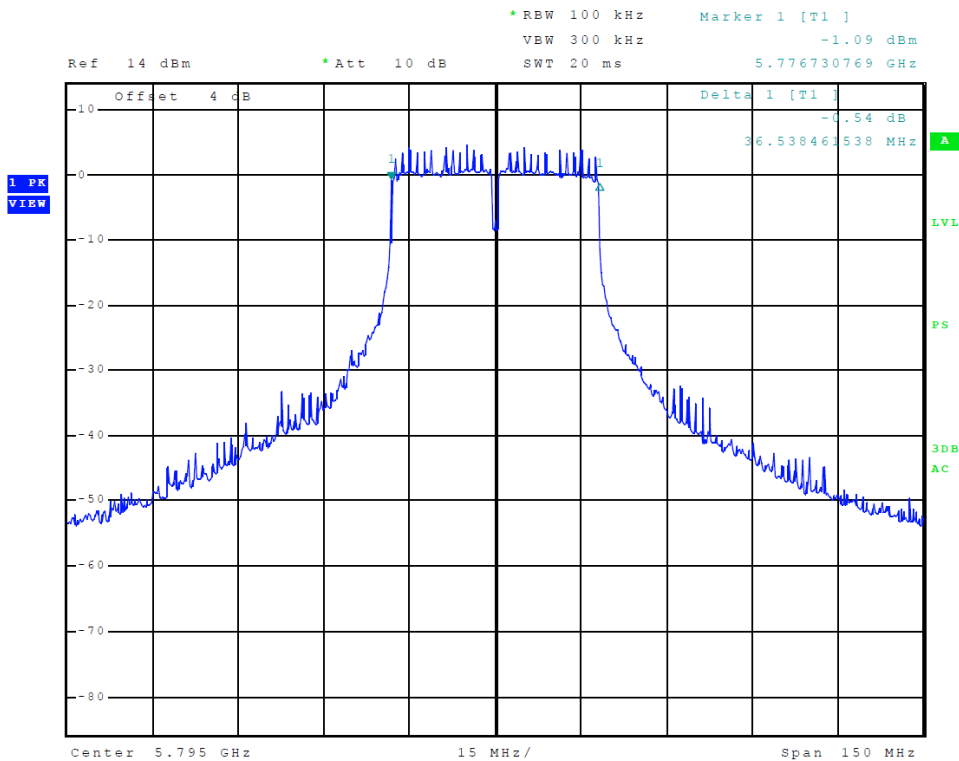

Figure 58 Plot of Transmitter Emissions (5725-5850 MHz Band, 802.11n40, Chain 1, 6-dB OBW)

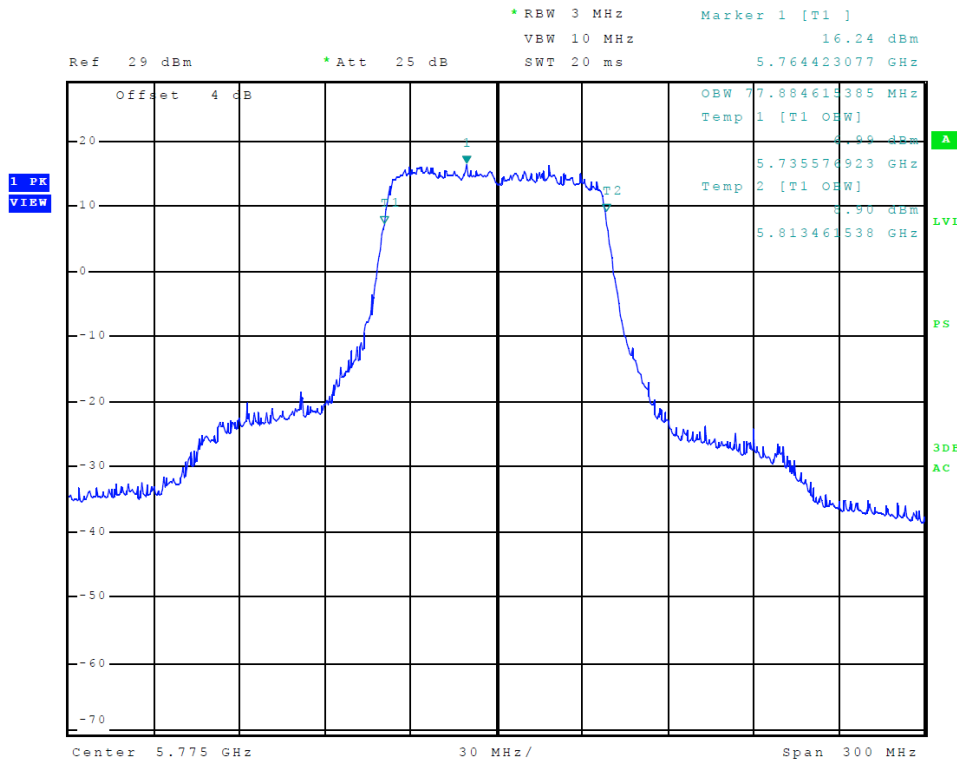

Figure 59 Plot of Transmitter Emissions (5725-5850 MHz Band, 802.11ac, Chain 0, 99% OBW)

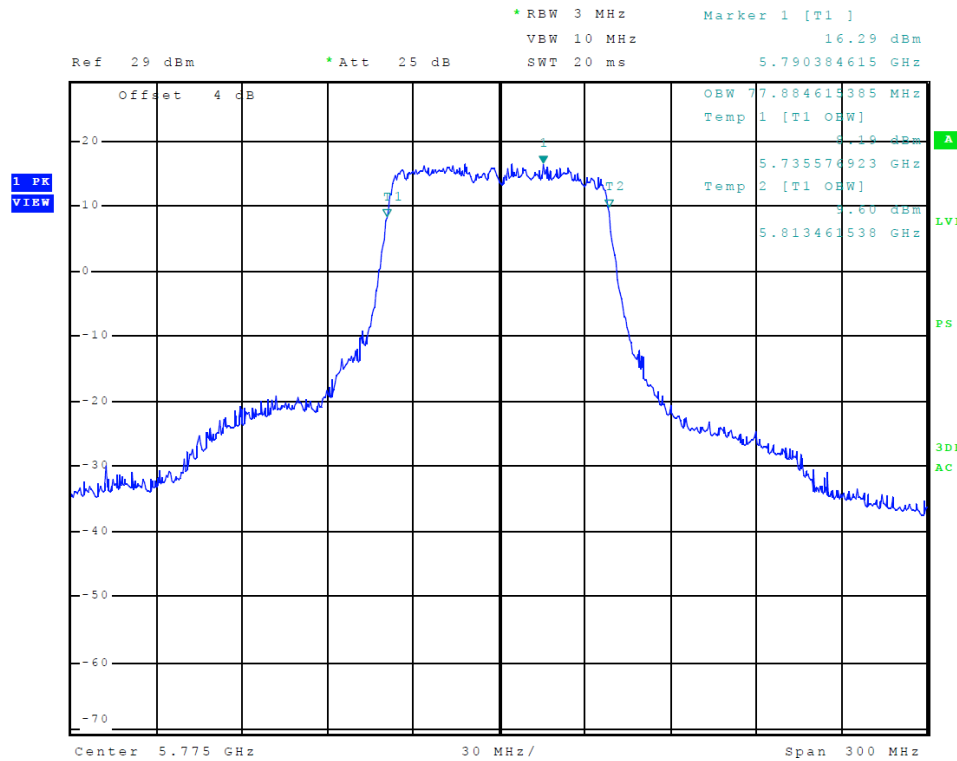

Figure 60 Plot of Transmitter Emissions (5725-5850 MHz Band, 802.11ac, Chain 1, 99% OBW)

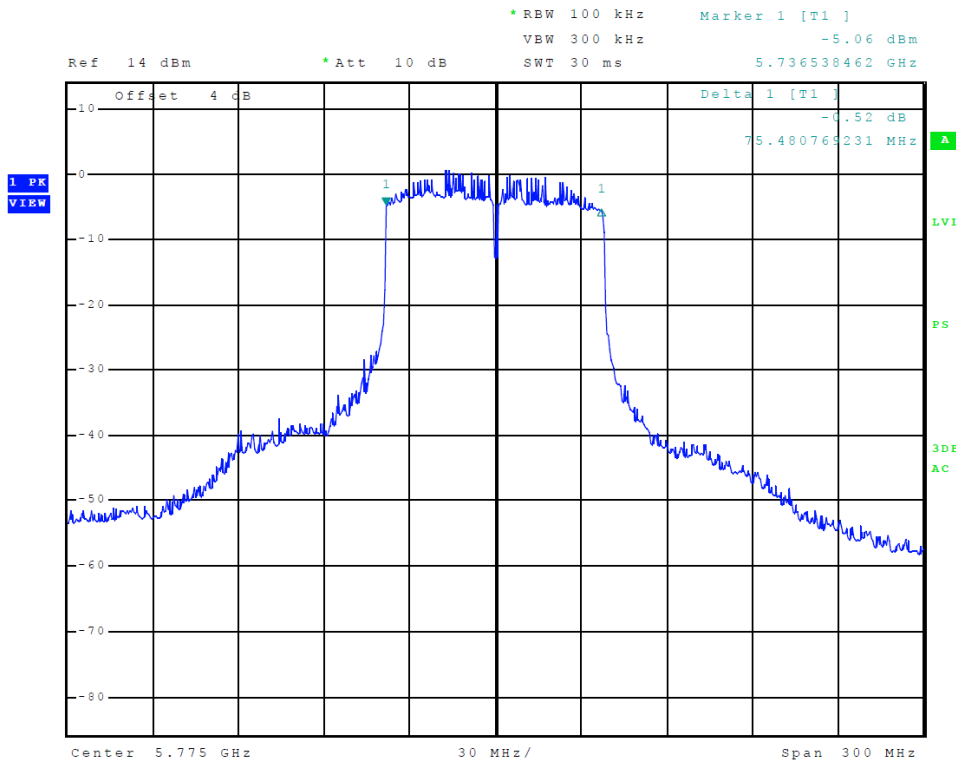

Figure 61 Plot of Transmitter Emissions (5725-5850 MHz Band, 802.11ac, Chain 0, 6-dB OBW)

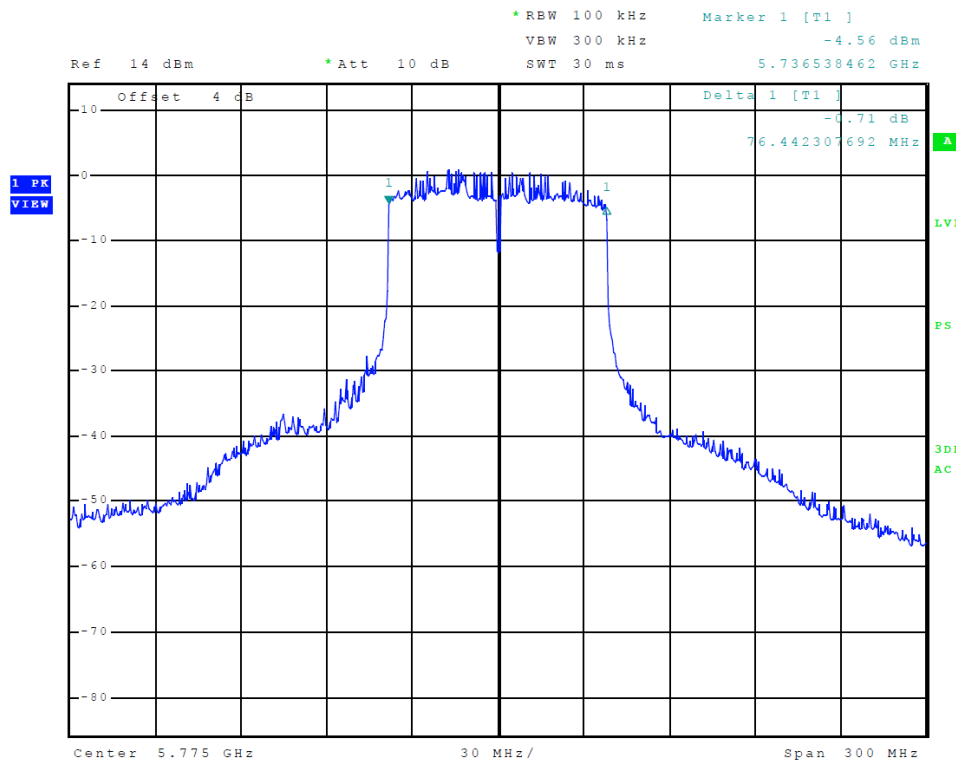

Figure 62 Plot of Transmitter Emissions (5725-5850 MHz Band, 802.11ac, Chain 1, 6-dB OBW)

Transmitter Emissions Data

Table 12 Transmitter Radiated Emission (802.11a, 5150-5250 MHz Band) 9dBi Omni

Frequency in MHz	Horizontal Peak (dB μ V/m)	Horizontal Average (dB μ V/m)	Vertical Peak (dB μ V/m)	Vertical Average (dB μ V/m)	Limit @ 3m (dB μ V/m)
20 MHz Channel					
5180.0	--	--	--	--	--
10360.0	49.8	36.5	49.7	36.4	68.3
15540.0	55.2	42.0	54.7	41.7	68.3
20720.0	57.6	44.9	57.9	44.8	68.3
25900.0	61.3	48.4	61.5	48.7	68.3
5200.0	--	--	--	--	--
10400.0	48.9	36.2	48.9	36.1	68.3
15600.0	53.8	40.8	53.8	40.7	68.3
20800.0	56.7	43.9	56.3	43.8	68.3
26000.0	62.0	49.2	62.0	49.2	68.3
5240.0	--	--	--	--	--
10480.0	49.8	37.1	49.8	36.8	68.3
15720.0	57.2	43.7	55.8	43.1	68.3
20960.0	56.9	44.0	56.4	43.8	68.3
26200.0	61.5	48.3	62.0	48.2	68.3
Band Edges					
5150.0	49.8	35.2	62.1	44.3	54.0
5350.0	45.3	32.9	52.0	37.9	54.0

Other emissions present had amplitudes at least 20 dB below the limit. Peak and Quasi-Peak amplitude emissions are recorded above for frequency range of 30-1000 MHz. Peak and Average amplitude emissions are recorded above for frequency range above 1000 MHz.

Table 13 Transmitter Radiated Emission (802.11a, 5725-5850 MHz Band) 9dBi Omni

Frequency in MHz	Horizontal Peak (dB μ V/m)	Horizontal Average (dB μ V/m)	Vertical Peak (dB μ V/m)	Vertical Average (dB μ V/m)	Limit @ 3m (dB μ V/m)
20 MHz Channel					
5745.0	--	--	--	--	--
11490.0	50.2	36.8	50.8	38.0	68.3
17235.0	55.8	43.0	55.7	43.0	68.3
22980.0	60.7	48.1	60.4	47.6	68.3
28725.0	65.0	51.9	64.8	51.9	68.3
5785.0	--	--	--	--	--
11570.0	49.5	36.3	51.0	37.7	68.3
17355.0	55.7	42.7	56.1	42.8	68.3
23140.0	60.0	47.4	60.4	47.5	68.3
28925.0	63.4	50.8	63.9	50.8	68.3
5825.0	--	--	--	--	--
11650.0	50.3	37.7	52.0	38.8	68.3
17475.0	57.2	44.2	56.4	43.6	68.3
23300.0	60.0	47.4	60.9	47.5	68.3
29125.0	64.1	50.8	63.8	50.8	68.3
Band Edges					
5725.0	58.5	40.1	80.7	62.6	78.2
5850.0	46.2	32.9	62.6	47.3	78.2

Other emissions present had amplitudes at least 20 dB below the limit. Peak and Quasi-Peak amplitude emissions are recorded above for frequency range of 30-1000 MHz. Peak and Average amplitude emissions are recorded above for frequency range above 1000 MHz.

Table 14 Transmitter Radiated Emission (802.11n, 5150-5250 MHz Band) 9dBi Omni

Frequency in MHz	Horizontal Peak (dB μ V/m)	Horizontal Average (dB μ V/m)	Vertical Peak (dB μ V/m)	Vertical Average (dB μ V/m)	Limit @ 3m (dB μ V/m)
20 MHz Channel					
5180.0	--	--	--	--	--
10360.0	49.2	36.4	48.8	36.4	68.3
15540.0	55.8	42.0	54.5	41.8	68.3
20720.0	58.3	45.0	58.1	45.0	68.3
25900.0	62.4	49.3	62.2	49.4	68.3
5200.0	--	--	--	--	--
10400.0	49.3	36.1	49.2	36.0	68.3
15600.0	53.9	40.9	54.1	40.9	68.3
20800.0	57.0	43.9	56.7	43.8	68.3
26000.0	61.7	49.1	62.6	49.0	68.3
5240.0	--	--	--	--	--
10480.0	49.5	36.8	51.0	37.1	68.3
15720.0	56.5	43.7	56.5	43.7	68.3
20960.0	56.8	44.1	57.6	43.9	68.3
26200.0	61.2	48.2	61.8	48.2	68.3
Band Edges					
5150.0	50.3	35.5	66.0	47.3	54.0
5350.0	45.9	32.9	50.7	37.5	54.0

Other emissions present had amplitudes at least 20 dB below the limit. Peak and Quasi-Peak amplitude emissions are recorded above for frequency range of 30-1000 MHz. Peak and Average amplitude emissions are recorded above for frequency range above 1000 MHz.

Table 15 Transmitter Radiated Emission (802.11n, 5725-5850 MHz Band) 9dBi Omni

Frequency in MHz	Horizontal Peak (dB μ V/m)	Horizontal Average (dB μ V/m)	Vertical Peak (dB μ V/m)	Vertical Average (dB μ V/m)	Limit @ 3m (dB μ V/m)
20 MHz Channel					
5745.0	--	--	--	--	--
11490.0	49.6	36.8	51.2	37.8	68.3
17235.0	56.1	43.0	55.5	42.9	68.3
22980.0	60.5	48.1	60.2	47.7	68.3
28725.0	64.8	51.9	64.6	51.9	68.3
5785.0	--	--	--	--	--
11570.0	49.0	36.3	51.7	37.7	68.3
17355.0	55.5	42.7	55.6	42.7	68.3
23140.0	60.2	47.4	60.3	47.5	68.3
28925.0	64.2	50.7	63.4	50.7	68.3
5825.0	--	--	--	--	--
11650.0	50.6	37.7	51.3	38.7	68.3
17475.0	57.2	43.8	56.5	43.8	68.3
23300.0	60.7	47.7	61.0	48.1	68.3
29125.0	64.9	52.0	65.0	52.0	68.3
Band Edges					
5725.0	56.3	39.4	81.2	62.5	78.2
5850.0	46.0	32.9	63.1	47.5	78.2

Other emissions present had amplitudes at least 20 dB below the limit. Peak and Quasi-Peak amplitude emissions are recorded above for frequency range of 30-1000 MHz. Peak and Average amplitude emissions are recorded above for frequency range above 1000 MHz.

Table 16 Transmitter Radiated Emission (802.11n, 5150-5250 MHz Band) 9dBi Omni

Frequency in MHz	Horizontal Peak (dB μ V/m)	Horizontal Average (dB μ V/m)	Vertical Peak (dB μ V/m)	Vertical Average (dB μ V/m)	Limit @ 3m (dB μ V/m)
40 MHz Channel					
5190.0	--	--	--	--	--
10380.0	49.2	36.3	49.7	36.4	68.3
15570.0	54.7	42.0	54.5	41.9	68.3
20760.0	57.3	44.5	57.5	44.4	68.3
25950.0	62.4	49.6	62.5	49.5	68.3
5200.0	--	--	--	--	--
10460.0	50.1	36.3	49.9	36.5	68.3
15690.0	55.4	42.4	54.7	42.2	68.3
20920.0	57.3	44.5	57.1	44.3	68.3
26150.0	62.1	49.1	62.5	49.0	68.3
Band Edges					
5150.0	46.0	32.9	66.8	50.2	54.0
5350.0	45.5	32.7	48.9	35.1	54.0

Other emissions present had amplitudes at least 20 dB below the limit. Peak and Quasi-Peak amplitude emissions are recorded above for frequency range of 30-1000 MHz. Peak and Average amplitude emissions are recorded above for frequency range above 1000 MHz.

Table 17 Transmitter Radiated Emission (802.11n, 5725-5850 MHz Band) 9dBi Omni

Frequency in MHz	Horizontal Peak (dB μ V/m)	Horizontal Average (dB μ V/m)	Vertical Peak (dB μ V/m)	Vertical Average (dB μ V/m)	Limit @ 3m (dB μ V/m)
40 MHz Channel					
5755.0	--	--	--	--	--
11510.0	49.3	36.8	50.1	36.9	68.3
17265.0	56.2	43.1	55.8	43.1	68.3
23020.0	61.1	48.3	61.5	48.2	68.3
28775.0	64.7	51.9	64.6	51.9	68.3
5795.0	--	--	--	--	--
11590.0	49.7	36.8	50.1	37.0	68.3
17385.0	56.1	43.1	56.1	43.1	68.3
23180.0	60.4	47.2	60.3	47.2	68.3
28975.0	63.2	49.9	62.9	49.9	68.3
Band Edges					
5725.0	45.6	32.4	68.1	50.8	78.2
5850.0	45.7	32.8	56.8	42.4	78.2

Other emissions present had amplitudes at least 20 dB below the limit. Peak and Quasi-Peak amplitude emissions are recorded above for frequency range of 30-1000 MHz. Peak and Average amplitude emissions are recorded above for frequency range above 1000 MHz.

Table 18 Transmitter Radiated Emission (802.11ac, 5150-5250 MHz Band) 9dBi Omni

Frequency in MHz	Horizontal Peak (dB μ V/m)	Horizontal Average (dB μ V/m)	Vertical Peak (dB μ V/m)	Vertical Average (dB μ V/m)	Limit @ 3m (dB μ V/m)
80 MHz Channel					
5210.0	--	--	--	--	--
10420.0	49.1	36.2	50.0	36.0	68.3
15630.0	52.5	39.4	52.3	39.1	68.3
20840.0	59.9	46.8	59.7	46.6	68.3
26050.0	65.5	52.6	66.4	52.6	68.3
Band Edges					
5150.0	47.5	33.7	67.7	50.3	54.0
5350.0	45.6	32.7	51.0	36.3	54.0

Other emissions present had amplitudes at least 20 dB below the limit. Peak and Quasi-Peak amplitude emissions are recorded above for frequency range of 30-1000 MHz. Peak and Average amplitude emissions are recorded above for frequency range above 1000 MHz.

Table 19 Transmitter Radiated Emission (802.11ac, 5725-5850 MHz Band) 9dBi Omni

Frequency in MHz	Horizontal Peak (dB μ V/m)	Horizontal Average (dB μ V/m)	Vertical Peak (dB μ V/m)	Vertical Average (dB μ V/m)	Limit @ 3m (dB μ V/m)
80 MHz Channel					
5755.0	--	--	--	--	--
11550.0	48.9	36.2	49.3	36.3	68.3
17325.0	57.4	44.3	57.9	44.2	68.3
23100.0	60.4	47.9	61.8	47.9	68.3
28875.0	65.1	52.0	64.9	51.9	68.3
Band Edges					
5725.0	50.1	33.8	70.3	51.4	78.2
5850.0	49.8	32.9	59.0	43.6	78.2

Other emissions present had amplitudes at least 20 dB below the limit. Peak and Quasi-Peak amplitude emissions are recorded above for frequency range of 30-1000 MHz. Peak and Average amplitude emissions are recorded above for frequency range above 1000 MHz.

Table 20 Transmitter Radiated Emission (802.11a, 5150-5250 MHz Band) 24dBi Panel

Frequency in MHz	Horizontal Peak (dB μ V/m)	Horizontal Average (dB μ V/m)	Vertical Peak (dB μ V/m)	Vertical Average (dB μ V/m)	Limit @ 3m (dB μ V/m)
20 MHz Channel					
5180.0	--	--	--	--	--
10360.0	49.5	36.4	49.8	36.5	68.3
15540.0	54.7	41.8	54.8	41.8	68.3
20720.0	58.0	44.7	58.0	44.6	68.3
25900.0	62.9	49.4	62.4	49.4	68.3
5200.0	--	--	--	--	--
10400.0	49.3	36.1	49.4	36.2	68.3
15600.0	54.2	40.8	54.0	40.9	68.3
20800.0	56.3	43.7	56.2	43.7	68.3
26000.0	62.0	48.9	62.1	48.8	68.3
5240.0	--	--	--	--	--
10480.0	49.2	36.7	49.7	36.8	68.3
15720.0	55.9	43.2	57.3	43.2	68.3
20960.0	57.2	44.1	57.0	43.9	68.3
26200.0	62.1	48.2	61.4	48.2	68.3
Band Edges					
5150.0	46.3	33.1	70.2	50.4	54.0
5350.0	46.1	33.2	56.8	43.3	54.0

Other emissions present had amplitudes at least 20 dB below the limit. Peak and Quasi-Peak amplitude emissions are recorded above for frequency range of 30-1000 MHz. Peak and Average amplitude emissions are recorded above for frequency range above 1000 MHz.

Table 21 Transmitter Radiated Emission (802.11a, 5725-5850 MHz Band) 24dBi Panel

Frequency in MHz	Horizontal Peak (dB μ V/m)	Horizontal Average (dB μ V/m)	Vertical Peak (dB μ V/m)	Vertical Average (dB μ V/m)	Limit @ 3m (dB μ V/m)
20 MHz Channel					
5745.0	--	--	--	--	--
11490.0	49.7	36.8	49.9	36.8	68.3
17235.0	56.1	43.1	56.2	43.1	68.3
22980.0	60.7	47.6	60.9	47.9	68.3
28725.0	65.2	51.9	65.3	51.9	68.3
5785.0	--	--	--	--	--
11570.0	49.1	36.3	49.7	36.4	68.3
17355.0	55.8	42.8	56.3	42.8	68.3
23140.0	60.4	47.4	60.5	47.5	68.3
28925.0	63.8	50.8	63.8	50.8	68.3
5825.0	--	--	--	--	--
11650.0	50.6	37.7	50.5	37.7	68.3
17475.0	57.2	43.9	56.8	43.9	68.3
23300.0	61.2	48.1	60.9	48.0	68.3
29125.0	65.5	51.7	64.8	51.7	68.3
Band Edges					
5725.0	49.9	34.1	73.3	55.4	78.2
5850.0	57.9	33.3	63.0	42.2	78.2

Other emissions present had amplitudes at least 20 dB below the limit. Peak and Quasi-Peak amplitude emissions are recorded above for frequency range of 30-1000 MHz. Peak and Average amplitude emissions are recorded above for frequency range above 1000 MHz.

Table 22 Transmitter Radiated Emission (802.11n, 5150-5250 MHz Band) 24dBi Panel

Frequency in MHz	Horizontal Peak (dB μ V/m)	Horizontal Average (dB μ V/m)	Vertical Peak (dB μ V/m)	Vertical Average (dB μ V/m)	Limit @ 3m (dB μ V/m)
20 MHz Channel					
5180.0	--	--	--	--	--
10360.0	50.0	36.4	50.5	36.5	68.3
15540.0	54.6	41.9	55.1	42.1	68.3
20720.0	57.8	44.7	57.6	44.6	68.3
25900.0	62.3	49.4	62.4	49.4	68.3
5200.0	--	--	--	--	--
10400.0	49.4	36.1	49.1	36.2	68.3
15600.0	54.4	41.0	53.7	40.8	68.3
20800.0	57.1	43.7	56.9	43.7	68.3
26000.0	61.7	48.8	62.0	48.8	68.3
5240.0	--	--	--	--	--
10480.0	50.4	37.0	50.1	37.0	68.3
15720.0	56.0	43.2	55.8	43.2	68.3
20960.0	57.5	44.0	57.4	43.8	68.3
26200.0	61.1	48.2	60.7	48.2	68.3
Band Edges					
5150.0	46.2	33.1	70.3	51.1	54.0
5350.0	46.5	33.2	56.2	43.1	54.0

Other emissions present had amplitudes at least 20 dB below the limit. Peak and Quasi-Peak amplitude emissions are recorded above for frequency range of 30-1000 MHz. Peak and Average amplitude emissions are recorded above for frequency range above 1000 MHz.

Table 23 Transmitter Radiated Emission (802.11n, 5725-5850 MHz Band) 24dBi Panel

Frequency in MHz	Horizontal Peak (dB μ V/m)	Horizontal Average (dB μ V/m)	Vertical Peak (dB μ V/m)	Vertical Average (dB μ V/m)	Limit @ 3m (dB μ V/m)
20 MHz Channel					
5745.0	--	--	--	--	--
11490.0	49.8	36.8	49.9	36.8	68.3
17235.0	55.9	43.2	56.5	43.1	68.3
22980.0	60.6	47.8	60.7	47.5	68.3
28725.0	65.3	51.9	66.0	51.9	68.3
5785.0	--	--	--	--	--
11570.0	50.1	36.4	49.1	36.4	68.3
17355.0	56.4	42.8	55.7	42.8	68.3
23140.0	60.4	47.5	60.2	47.3	68.3
28925.0	63.7	50.8	64.1	50.8	68.3
5825.0	--	--	--	--	--
11650.0	51.0	37.7	50.4	37.7	68.3
17475.0	57.3	43.9	57.5	44.0	68.3
23300.0	60.7	48.1	60.6	47.7	68.3
29125.0	64.6	51.7	64.4	51.7	68.3
Band Edges					
5725.0	50.3	34.7	74.3	56.3	78.2
5850.0	56.8	32.9	58.5	42.5	78.2

Other emissions present had amplitudes at least 20 dB below the limit. Peak and Quasi-Peak amplitude emissions are recorded above for frequency range of 30-1000 MHz. Peak and Average amplitude emissions are recorded above for frequency range above 1000 MHz.

Table 24 Transmitter Radiated Emission (802.11n, 5150-5250 MHz Band) 24dBi Panel

Frequency in MHz	Horizontal Peak (dB μ V/m)	Horizontal Average (dB μ V/m)	Vertical Peak (dB μ V/m)	Vertical Average (dB μ V/m)	Limit @ 3m (dB μ V/m)
40 MHz Channel					
5190.0	--	--	--	--	--
10380.0	50.3	36.3	49.3	36.4	68.3
15570.0	55.1	42.0	55.3	42.0	68.3
20760.0	56.9	44.2	57.3	44.2	68.3
25950.0	62.5	49.4	62.6	49.4	68.3
5200.0	--	--	--	--	--
10460.0	50.1	36.5	49.3	36.5	68.3
15690.0	55.1	42.1	54.9	42.1	68.3
20920.0	57.2	44.3	57.0	44.2	68.3
26150.0	62.2	48.6	62.0	48.6	68.3
Band Edges					
5150.0	45.6	32.7	66.1	49.6	54.0
5350.0	45.3	32.7	50.6	37.4	54.0

Other emissions present had amplitudes at least 20 dB below the limit. Peak and Quasi-Peak amplitude emissions are recorded above for frequency range of 30-1000 MHz. Peak and Average amplitude emissions are recorded above for frequency range above 1000 MHz.

Table 25 Transmitter Radiated Emission (802.11n, 5725-5850 MHz Band) 24dBi Panel

Frequency in MHz	Horizontal Peak (dB μ V/m)	Horizontal Average (dB μ V/m)	Vertical Peak (dB μ V/m)	Vertical Average (dB μ V/m)	Limit @ 3m (dB μ V/m)
40 MHz Channel					
5755.0	--	--	--	--	--
11510.0	49.4	36.8	49.7	36.8	68.3
17265.0	56.3	43.3	56.6	43.2	68.3
23020.0	61.2	48.2	60.9	48.0	68.3
28775.0	65.3	52.0	65.6	52.0	68.3
5795.0	--	--	--	--	--
11590.0	49.8	36.8	49.7	36.8	68.3
17385.0	55.3	43.3	56.3	43.1	68.3
23180.0	60.3	47.1	60.2	47.2	68.3
28975.0	63.6	50.2	63.0	50.1	68.3
Band Edges					
5725.0	50.8	34.6	75.1	59.9	78.2
5850.0	45.7	33.0	54.9	41.2	78.2

Other emissions present had amplitudes at least 20 dB below the limit. Peak and Quasi-Peak amplitude emissions are recorded above for frequency range of 30-1000 MHz. Peak and Average amplitude emissions are recorded above for frequency range above 1000 MHz.

Table 26 Transmitter Radiated Emission (802.11ac, 5150-5250 MHz Band) 24dBi Panel

Frequency in MHz	Horizontal Peak (dBµV/m)	Horizontal Average (dBµV/m)	Vertical Peak (dBµV/m)	Vertical Average (dBµV/m)	Limit @ 3m (dBµV/m)
80 MHz Channel					
5210.0	--	--	--	--	--
10420.0	49.3	36.2	49.4	36.2	68.3
15630.0	53.0	39.4	52.6	39.5	68.3
20840.0	56.2	43.5	56.4	43.7	68.3
26050.0	61.7	48.6	62.2	48.6	68.3
Band Edges					
5150.0	46.8	33.4	67.4	50.4	54.0
5350.0	45.8	32.7	51.4	38.0	54.0

Other emissions present had amplitudes at least 20 dB below the limit. Peak and Quasi-Peak amplitude emissions are recorded above for frequency range of 30-1000 MHz. Peak and Average amplitude emissions are recorded above for frequency range above 1000 MHz.

Table 27 Transmitter Radiated Emission (802.11ac, 5725-5850 MHz Band) 24dBi Panel

Frequency in MHz	Horizontal Peak (dBµV/m)	Horizontal Average (dBµV/m)	Vertical Peak (dBµV/m)	Vertical Average (dBµV/m)	Limit @ 3m (dBµV/m)
80 MHz Channel					
5755.0	--	--	--	--	--
11550.0	49.1	36.2	49.4	36.2	68.3
17325.0	57.1	44.3	57.6	44.3	68.3
23100.0	61.5	47.9	61.3	47.9	68.3
28875.0	64.8	51.9	64.8	51.8	68.3
Band Edges					
5725.0	50.1	33.8	76.7	58.8	78.2
5850.0	48.0	33.1	68.0	51.5	78.2

Other emissions present had amplitudes at least 20 dB below the limit. Peak and Quasi-Peak amplitude emissions are recorded above for frequency range of 30-1000 MHz. Peak and Average amplitude emissions are recorded above for frequency range above 1000 MHz.

Table 28 Transmitter Antenna Port Conducted Power and Emissions (Chain 0)

Frequency MHz	Conducted Antenna Port Average Output Power (Watts)	99% Occupied Bandwidth (kHz)	Peak Power Spectral Density (dBm)
20 MHz Mode 802.11a			
5180	0.031	17,500.0	-5.4 dBm/1MHz
5200	0.032	17,500.0	-5.0 dBm/1MHz
5240	0.030	17,500.0	-5.5 dBm/1MHz
40 MHz Mode 802.11n			
5190	0.007	37,500.0	-9.3 dBm/1MHz
5230	0.007	37,500.0	-9.6 dBm/1MHz
80 MHz Mode 802.11ac			
5210	0.008	77,884.6	-13.0 dBm/1MHz
20 MHz Mode 802.11a			
5745	0.083	17,596.2	3.7 dBm/500kHz
5785	0.088	17,500.0	3.8 dBm/500kHz
5825	0.090	17,403.8	3.5 dBm/500kHz
40 MHz Mode 802.11n			
5755	0.068	37,500.0	-1.3 dBm/500kHz
5795	0.071	37,500.0	-0.9 dBm/500kHz
80 MHz Mode 802.11ac			
5775	0.061	77,884.6	-5.1 dBm/500kHz

Table 29 Transmitter Antenna Port Conducted Power and Emissions (Chain 1)

Frequency MHz	Conducted Antenna Port Average Output Power (Watts)	99% Occupied Bandwidth (kHz)	Peak Power Spectral Density (dBm)
20 MHz Mode 802.11a			
5180	0.038	17,115.4	-3.4 dBm/1MHz
5200	0.036	17,115.4	-3.2 dBm/1MHz
5240	0.033	17,115.4	-3.1 dBm/1MHz
40 MHz Mode 802.11n			
5190	0.008	37,259.6	-9.2 dBm/1MHz
5230	0.007	37,500.0	-9.4 dBm/1MHz
80 MHz Mode 802.11ac			
5210	0.07	77,884.6	-13.1 dBm/1MHz
20 MHz Mode 802.11a			
5745	0.103	17,211.5	3.2 dBm/500kHz
5785	0.099	17,211.5	2.9 dBm/500kHz
5825	0.104	17,211.5	2.5 dBm/500kHz
40 MHz Mode 802.11n			
5755	0.078	37,259.6	-1.9 dBm/500kHz
5795	0.079	37,500.0	-1.7 dBm/500kHz
80 MHz Mode 802.11ac			
5775	0.067	77,884.6	-4.6 dBm/500kHz

Table 30 Transmitter Antenna Port Conducted Power and Emissions (Total All Chains)

Frequency MHz	Total Conducted Antenna Port Average Output Power (Watts)	99% Occupied Bandwidth (kHz)	Peak Power Spectral Density (dBm)
20 MHz Mode 802.11a			
5180	0.069	17,500	-1.3 dBm/1MHz
5200	0.068	17,500	-1.0 dBm/1MHz
5240	0.063	17,500	-1.1 dBm/1MHz
40 MHz Mode 802.11n			
5190	0.015	37,500	-6.2 dBm/1M
5230	0.014	37,500	-6.5 dBm/1M
80 MHz Mode 802.11ac			
5210	0.014	77,885	-10.0 dBm/1M
20 MHz Mode 802.11a			
5745	0.186	17,596	6.5 dBm/500kHz
5785	0.187	17,500	6.4 dBm/500kHz
5825	0.194	17,404	6.0 dBm/500kHz
40 MHz Mode 802.11n			
5755	0.146	37,500	1.4 dBm/500kHz
5795	0.150	37,500	1.7 dBm/500kHz
80 MHz Mode 802.11ac			
5775	0.128	77,885	-1.8 dBm/500kHz

Summary of Results for Transmitter Radiated Emissions of Intentional Radiator

The EUT demonstrated compliance with the radiated emissions requirements of 47CFR Part 15.407 and Industry Canada RSS-247 Issue 2. The maximum measured average conducted power delivered to all antennas was 0.069-Watts in the U-NII-1 band and 0.194-Watts in the U-NII-3. The minimum radiated harmonic emission margin provided -16.3 dB margin below requirements. General radiated emissions of EUT and supporting equipment provided -4.7 dB margin. There were no other significantly measurable emissions in the restricted bands other than those presented in this report. Other emissions were present with amplitudes at least 20 dB below the requirements. There were no other deviations or exceptions to the requirements.

Statement of Modifications and Deviations

No modifications to the EUT were required for the unit to demonstrate compliance with the 47CFR Part 15E and Industry Canada RSS-247 Issue 2 emissions requirements. There were no deviations or modifications to the specifications.

Annex

- Annex A Measurement Uncertainty Calculations
- Annex B Additional Test Equipment List
- Annex C Rogers Qualifications
- Annex D Rogers Labs Certificate of Accreditation

Annex A Measurement Uncertainty Calculations

The measurement uncertainty was calculated for all measurements listed in this test report according To CISPR 16-4. Result of measurement uncertainty calculations are recorded below. Component and process variability of production devices similar to those tested may result in additional deviations. The manufacturer has the sole responsibility of continued compliance.

Measurement	Expanded Measurement Uncertainty $U_{(lab)}$
3 Meter Horizontal 0.009-1000 MHz Measurements	4.16
3 Meter Vertical 0.009-1000 MHz Measurements	4.33
3 Meter Measurements 1-18 GHz	5.14
3 Meter Measurements 18-40 GHz	5.16
10 Meter Horizontal Measurements 0.009-1000 MHz	4.15
10 Meter Vertical Measurements 0.009-1000 MHz	4.32
AC Line Conducted	1.75
Antenna Port Conducted power	1.17
Frequency Stability	1.00E-11
Temperature	1.6°C
Humidity	3%

Annex B Additional Test Equipment List

List of Test Equipment	Calibration	Date (m/d/y)	Due
Antenna: Schwarzbeck Model: BBA 9106/VHBB 9124 (9124-627)		5/2/2018	5/2/2019
Antenna: Schwarzbeck Model: VULP 9118 A (VULP 9118 A-534)		5/2/2018	5/2/2019
Antenna: EMCO 6509		10/16/2018	10/16/2020
Antenna: EMCO 3143 (9607-1277) 20-1200 MHz		5/2/2018	5/2/2019
Antenna: EMCO Dipole Set 3121C		2/23/2018	2/23/2019
Antenna: C.D. B-101		2/23/2018	2/23/2019
Antenna: Solar 9229-1 & 9230-1		2/23/2018	2/23/2019
Cable: Belden 8268 (L3)		10/16/2018	10/16/2019
Cable: Time Microwave: 4M-750HF290-750		10/16/2018	10/16/2019
Frequency Counter: Leader LDC-825 (8060153)		5/2/2018	5/2/2019
Oscilloscope Scope: Tektronix 2230		2/23/2018	2/23/2019
Wattmeter: Bird 43 with Load Bird 8085		2/23/2018	2/23/2019
R.F. Generator: SMB100A6 s/n 100623		5/2/2018	5/2/2019
R.F. Generator: SBMBV100A s/n: 260771		5/2/2018	5/2/2019
R.F. Generators: HP 606A, HP 8614A, HP 8640B		2/23/2018	2/23/2019
R.F. Power Amp 65W Model: 470-A-1010		2/23/2018	2/23/2019
R.F. Power Amp 50W M185- 10-501		2/23/2018	2/23/2019
R.F. Power Amp A.R. Model: 10W 1010M7		2/23/2018	2/23/2019
R.F. Power Amp EIN Model: A301		2/23/2018	2/23/2019
LISN: Compliance Eng. Model 240/20		5/2/2018	5/2/2019
LISN: Fischer Custom Communications Model: FCC-LISN-50-16-2-08		5/2/2018	5/2/2019
Audio Oscillator: H.P. 201CD		2/23/2018	2/23/2019
ESD Test Set 2010i		2/23/2018	2/23/2019
Oscilloscope Scope: Tektronix MDO 4104		2/23/2018	2/23/2019
EMC Transient Generator HVT TR 3000		2/23/2018	2/23/2019
AC Power Source (Ametech, California Instruments)		2/23/2018	2/23/2019
Fast Transient Burst Generator Model: EFT/B-101		2/23/2018	2/23/2019
Field Intensity Meter: EFM-018		2/23/2018	2/23/2019
KEYTEK Ecat Surge Generator		2/23/2018	2/23/2019
ESD Simulator: MZ-15		2/23/2018	2/23/2019
Shielded Room not required			

Annex C Rogers Qualifications

Scot D. Rogers, Engineer

Rogers Labs, Inc.

Mr. Rogers has approximately 30 years' experience in the field of electronics. Engineering experience includes six years in the automated controls industry and remaining years working with the design, development and testing of radio communications and electronic equipment.

Positions Held

Systems Engineer: A/C Controls Mfg. Co., Inc. 6 Years

Electrical Engineer: Rogers Consulting Labs, Inc. 5 Years

Electrical Engineer: Rogers Labs, Inc. Current

Educational Background

- 1) Bachelor of Science Degree in Electrical Engineering from Kansas State University.
- 2) Bachelor of Science Degree in Business Administration Kansas State University.
- 3) Several Specialized Training courses and seminars pertaining to Microprocessors and Software programming.

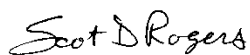

Scot D. Rogers

Annex D Rogers Labs Certificate of Accreditation

United States Department of Commerce
National Institute of Standards and Technology

NVLAP®

Certificate of Accreditation to ISO/IEC 17025:2005

NVLAP LAB CODE: 200087-0

Rogers Labs, Inc.
Louisburg, KS

*is accredited by the National Voluntary Laboratory Accreditation Program for specific services,
listed on the Scope of Accreditation, for:*

Electromagnetic Compatibility & Telecommunications

*This laboratory is accredited in accordance with the recognized International Standard ISO/IEC 17025:2005.
This accreditation demonstrates technical competence for a defined scope and the operation of a laboratory quality
management system (refer to joint ISO-ILAC-IAF Communique dated January 2009).*

2018-02-21 through 2019-03-31
Effective Dates



For the National Voluntary Laboratory Accreditation Program

Rogers Labs, Inc.
4405 W. 259th Terrace
Louisburg, KS 66053
Phone/Fax: (913) 837-3214
Revision 2

Mikrotikls SIA
Model: R11e-5HacD
Test #: 181029
Test to: 47CFR, 15.407, RSS-247
File: Mikrotikls R11e5HacD TstRpt 181029 r2

S/N: 8EDC0800A953/814/r2
FCC ID: TV7R11E5HAM
IC: 7442A- R11E5HAM
Date: January 31, 2019
Page 92 of 92