

Submittal Application Report

FOR
Grant Of Certification

FOR

Model: RBmAP L-2nD
2412-2462 MHz
Broadband Digital Transmission System
FCC ID: TV7MAPL2ND
IC: 7442A-MAPL2ND

FOR

Mikrotikls SIA
Pernavas 46
Riga, Latvia LV-1009

Test Report Number: 150730A-151104
IC Test Site Registration: 3041A-1

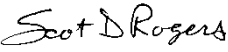
Authorized Signatory: 
Scot D. Rogers

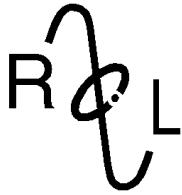

ROGERS LABS, INC.

4405 West 259th Terrace
Louisburg, KS 66053
Phone / Fax (913) 837-3214

Engineering Test Report for Grant of Certification Application

FOR
Broadband Digital Transmission System
CFR 47, PART 15C - Paragraph 15.247
License Exempt Intentional Radiator

For

Mikrotikls SIA

Pernavas 46
Riga, Latvia LV-1009

Broadband Digital Transmission System

Model: RBmAP L-2nD
Frequency Range 2412-2462 MHz
FCC ID#: TV7MAPL2ND
IC: 7442A-MAPL2ND

Test Date: November 4, 2015

Certifying Engineer: *Scot D. Rogers*
Scot D. Rogers
Rogers Labs, Inc.
4405 West 259th Terrace
Louisburg, KS 66053
Telephone/Facsimile: (913) 837-3214

This report shall not be reproduced except in full, without the written approval of the laboratory.
This report must not be used by the client to claim product certification, approval, or endorsement by
NVLAP, NIST, or any agency of the Federal Government.

Rogers Labs, Inc.
4405 W. 259th Terrace
Louisburg, KS 66053
Phone/Fax: (913) 837-3214
Revision 2

Mikrotikls SIA
Model: RBmAP L-2nD
Test #: 150730A-151104
Test to: 47CFR 15.247, RSS-247
File: Mikrotikls RBmAPL2ND 150730A r2 Page 2 of 33

S/N: 642A01DDE062
FCC ID#: TV7MAPL2ND
IC: 7442A-MAPL2ND
Date: December 22, 2015

Table Of Contents

| | |
|---|-----------|
| TABLE OF CONTENTS..... | 3 |
| REVISIONS..... | 4 |
| FORWARD | 5 |
| OPINION / INTERPRETATION OF RESULTS | 5 |
| EQUIPMENT TESTED..... | 5 |
| EQUIPMENT FUNCTION AND CONFIGURATION..... | 6 |
| Equipment Configuration..... | 6 |
| APPLICATION FOR CERTIFICATION..... | 7 |
| APPLICABLE STANDARDS & TEST PROCEDURES | 8 |
| EQUIPMENT TESTING PROCEDURES | 8 |
| AC Line Conducted Emission Test Procedure | 8 |
| Radiated Emission Test Procedure..... | 8 |
| Diagram 1 Test arrangement for Conducted emissions | 9 |
| Diagram 2 Test arrangement for radiated emissions of tabletop equipment..... | 10 |
| Diagram 3 Test arrangement for radiated emissions tested on Open Area Test Site (OATS)..... | 11 |
| TEST SITE LOCATIONS | 11 |
| LIST OF TEST EQUIPMENT | 12 |
| UNITS OF MEASUREMENTS | 12 |
| ENVIRONMENTAL CONDITIONS..... | 13 |
| INTENTIONAL RADIATORS..... | 13 |
| Antenna Requirements | 13 |
| Restricted Bands of Operation..... | 13 |
| Table 1 General Radiated Emissions in Restricted Bands Data | 14 |
| Summary of Results for Radiated Emissions in Restricted Bands | 14 |
| AC Line Conducted Emissions Procedure | 15 |
| Figure 1 AC Line Conducted Emissions Line 1 | 16 |
| Figure 2 AC Line Conducted Emissions Line 2 | 16 |
| Table 2 AC Line Conducted Emissions Data (Highest Emissions Line L1) | 17 |
| Table 3 AC Line Conducted Emissions Data (Highest Emissions Line L2) | 17 |
| Summary of Results for AC Line Conducted Emissions | 17 |
| General Radiated Emissions Procedure..... | 18 |
| Table 4 General Radiated Emissions from EUT Data (Highest Emissions)..... | 19 |
| Summary of Results for General Radiated Emissions | 19 |
| Operation in the 2400-2483.5 MHz Frequency Band..... | 20 |
| Figure 3 Plot of Transmitter Emissions (Across Operational Band 802.11b) | 21 |

Figure 4 Plot of Transmitter Emissions (Across Operational Band, 802.11g)21
 Figure 5 Plot of Transmitter Emissions (Across Operational Band, 802.11n)22
 Figure 6 Plot of Transmitter Low Band Edge (802.11b)22
 Figure 7 Plot of Transmitter Low Band Edge (802.11g)23
 Figure 8 Plot of Transmitter Low Band Edge (802.11n)23
 Figure 9 Plot of Transmitter High Band Edge (802.11b)24
 Figure 10 Plot of Transmitter High Band Edge (802.11g)24
 Figure 11 Plot of Transmitter High Band Edge (802.11n)25
Transmitter Emissions Data.....25
 Table 5 Transmitter Power and Emissions25
 Table 6 Transmitter Radiated Emission.....26
Summary of Results for Transmitter Radiated Emissions of Intentional Radiator.....27
STATEMENT OF MODIFICATIONS AND DEVIATIONS 27
ANNEX..... 28
 Annex A Measurement Uncertainty Calculations.....29
 Annex B Rogers Labs Test Equipment List.....30
 Annex C Rogers Qualifications30
 Annex D FCC Site Registration Letter.....32
 Annex E Industry Canada Site Registration Letter33

Revisions

Revision 2 Issued December 22, 2015 – corrected pages 12 and 30 (updated equipment calibration)

Forward

The following information is submitted for consideration in obtaining Grant of Certification for License Exempt Digital Transmission System Intentional Radiator operating under 47CFR Paragraph 15.247 and RSS-247 Issue 1 Digital Modulation transmitter operation in the 2412-2462 MHz band.

Name of Applicant: Mikrotiks SIA FRN: 0014 43 1100
 Pernavas 46
 Riga, Latvia LV-1009

Model: RBmAP L-2nD

FCC ID: TV7MAPL2ND IC: 7442A-MAPL2ND

Frequency Range: 2412-2462 MHz (802.11b/g/n mode operation), 2422-2452 MHz (802.11n 40 MHz channel operation)

Total Operating Power: Maximum 0.161-watt total output power (0.08 watts per chain),
 OBW 16,860 or 36,480 kHz

Opinion / Interpretation of Results

| Tests Performed | Margin (dB) | Results |
|---|-------------|----------|
| Restricted Frequency Bands 15.205, RSS-GEN 8.10 | -5.3 | Complies |
| AC Line Conducted 15.207, RSS-GEN 7.2.4 | -10.4 | Complies |
| Radiated Emissions 15.209, RSS-GEN 7.2.5 | -9.2 | Complies |
| Harmonic Emissions per 15.247, RSS-247 | -5.3 | Complies |
| Peak Power Spectral Density per 15.247, RSS-247 | -15.9 | Complies |

Equipment Tested

| <u>Equipment</u> | <u>Model</u> | <u>FCC I.D.</u> |
|------------------|--------------|-----------------|
| EUT | RBmAP L-2nD | TV7MAPL2ND |
| AC Adapter | HJ-0501000 | N/A |
| Dell Studio XPS | 921LBN1 | N/A |

Equipment Function and Configuration

The EUT is a 2412-2462 MHz Digital Transmission System used to transmit data in applications offering broadband wireless connectivity. The design utilizes internal fixed antenna system and offers no provision for antenna replacement or modification. The equipment is marketed for use to provide a wireless link to exchange data information from one point to another. For testing purposes, the EUT transceiver was connected to the manufacturer supplied AC/DC supply and communicating to the laptop computer through Ethernet network interface. This configuration provided operational control of the EUT and communications over the network interface between the EUT and supporting computer system. No other interfacing options are provided. For testing purposes, the RBmAP L-2nD received powered from the manufacturer provided AC/DC power adapter and was configured to transmit in available data modes. The antenna system complies with requirements for unique antenna connection port.

Equipment Configuration

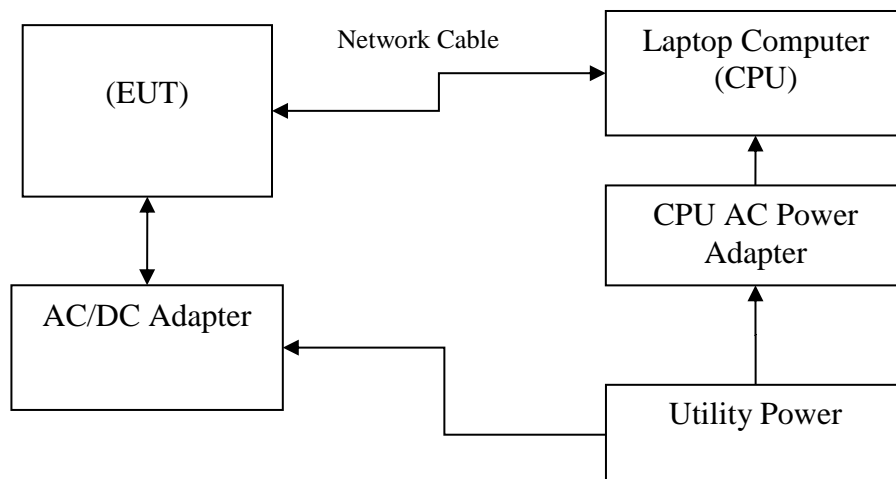

Application for Certification

- (1) Manufacturer: Mikrotikls SIA
Pernavas 46
Riga, Latvia LV-1009
- (2) Identification: Models: RBmAP L-2nD
FCC I.D.: TV7MAPL2ND IC: 7442A-MAPL2ND
- (3) Instruction Book:
Refer to Exhibit for Instruction Manual.
- (4) Description of Circuit Functions:
Refer to Exhibit of Operational Description.
- (5) Block Diagram with Frequencies:
Refer to Exhibit of Operational Description.
- (6) Report of Measurements:
Report of measurements follows in this Report.
- (7) Photographs: Construction, Component Placement, etc.:
Refer to Exhibit for photographs of equipment.
- (8) List of Peripheral Equipment Necessary for operation. The equipment operates from power received from authorized AC/DC power adapter. The EUT provides Ethernet and DC input power ports for operation. During testing, the EUT was connected to CPU through network cable.
- (9) Transition Provisions of 47CFR 15.37 are not requested
- (10) Not Applicable. The unit is not a scanning receiver.
- (11) Not Applicable. The EUT does not operate in the 59 – 64 GHz frequency band.
- (12) The equipment is not software defined and this section is not applicable.

Applicable Standards & Test Procedures

The following information is submitted in accordance 47CFR dated October 1, 2014, Part 2, Subpart J, Paragraphs 2.907, 2.911, 2.913, 2.925, 2.926, 2.1031 through 2.1057, and applicable parts of paragraph 15, Part 15C Paragraph 15.247 and Industry Canada RSS-247. Test procedures used are the established Methods of Measurement of Radio-Noise Emissions as described in ANSI C63.10-2013, KDB 558074 D01 v03r03, KDB 662911 D02 v01, and KDB 913591, RSS-247, Issue 1 and RSS-GEN Issue 4, the following information is submitted for processing application for Certification.

Equipment Testing Procedures

AC Line Conducted Emission Test Procedure

Testing for the AC line-conducted emissions was performed as defined in ANSI C63.10-2013. The test setup, including the EUT, was arranged in the test configurations as presented during testing. The test configuration was placed on a 1 x 1.5-meter wooden bench, 0.8 meters high located in a screen room. The power lines of the system were isolated from the power source using a standard LISN with a 50- μ Hy choke. EMI was coupled to the spectrum analyzer through a 0.1 μ F capacitor internal to the LISN. The LISN was positioned on the floor beneath the wooden bench supporting the EUT. The power lines and cables were draped over the back edge of the table. Refer to diagram 1 showing typical test arrangement and photographs in exhibits for EUT placement used during testing.

Radiated Emission Test Procedure

Radiated emission testing was performed as required and specified in ANSI C63.10-2013 and referenced KDB documents. The EUT was placed on a rotating 0.9 x 1.2-meter platform, elevated as required above the ground plane at a distance of 3 meters from the FSM antenna. The table permitted orientation of the EUT in each of three orthogonal axis positions during testing. EMI energy was maximized by equipment placement, raising and lowering the FSM antenna, changing the antenna polarization, and by rotating the turntable. Each emission was maximized before data was taken using a spectrum analyzer. The frequency spectrum from 9 kHz to 25,000 MHz was searched for during preliminary investigation. Refer to diagrams 2 and 3 showing typical test arrangement and photographs in the test setup exhibits for specific EUT placement during testing.

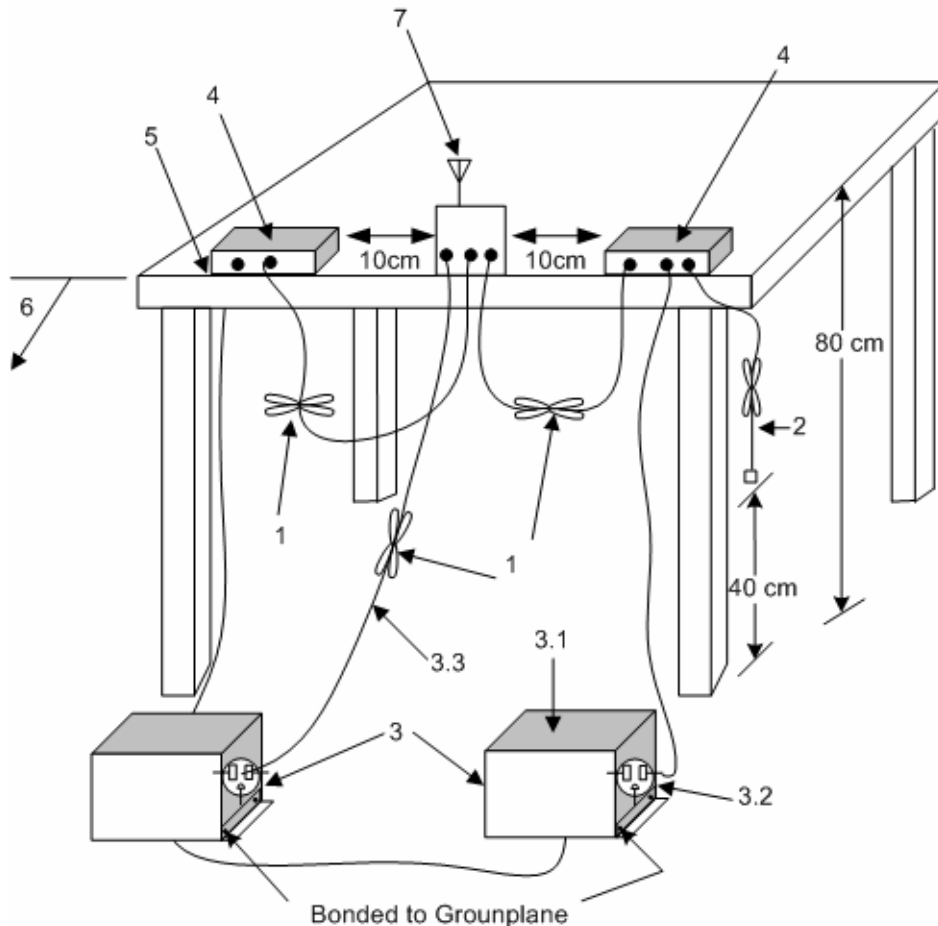

1. Interconnecting cables that hang closer than 40 cm to the ground plane shall be folded back and forth in the center forming a bundle 30 cm to 40 cm long see (see 6.2.3.2).
2. The I/O cables that are not connected to an accessory shall be bundled in the center. The end of the cable may be terminated, if required, using the correct terminating impedance. The overall length shall not exceed 1 m (see 6.2.2).
3. EUT connected to one LISN. Unused LISN measuring port connectors shall be terminated in 50 Ω loads. LISN may be placed on top of, or immediately beneath, reference ground plane (see 6.2.2 and 6.2.3).
 - 3.1 All other equipment powered from additional LISN(s).
 - 3.2 Multiple-outlet strip can be used for multiple power cords of non-EUT equipment.
 - 3.3 LISN at least 80 cm from nearest part of EUT chassis
4. Non-EUT components of EUT system being tested
5. Rear of EUT, including peripherals, shall all be aligned and flush with edge of tabletop (see 6.2.3.2).
6. Edge of tabletop shall be 40 cm removed from a vertical conducting plane that is bonded to the ground plane (see 6.2.2 for options).
7. Antenna may be integral or detachable. If detachable, the antenna shall be attached for this test.

Diagram 1 Test arrangement for Conducted emissions

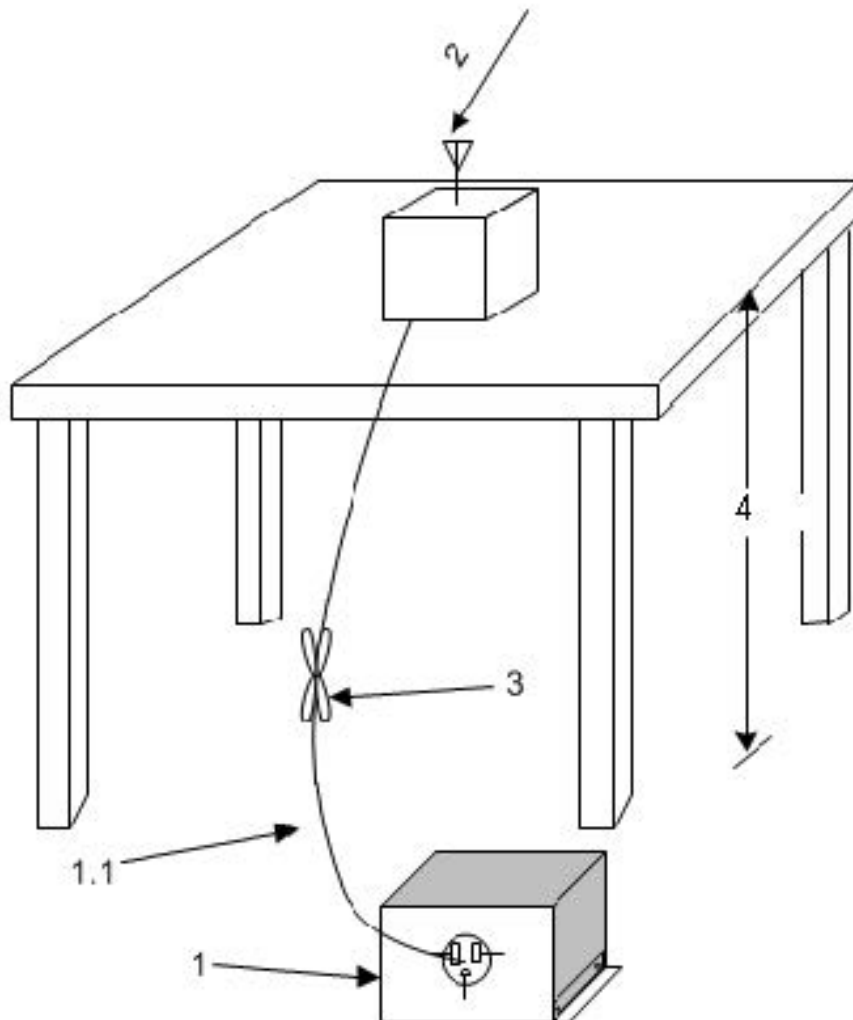

1. A LISN is optional for radiated measurements between 30 MHz and 1000 MHz but not allowed for measurements below 30 MHz and above 1000 MHz (see 6.3.1). If used, then connect EUT to one LISN. Unused LISN measuring port connectors shall be terminated in 50 Ω loads. The LISN may be placed on top of, or immediately beneath, the reference ground plane (see 6.2.2 and 6.2.3.2).
 - 1.1 LISN spaced at least 80 cm from nearest part of EUT chassis.
2. Antenna can be integral or detachable, depending on the EUT (see 6.3.1).
3. Interconnecting cables that hang closer than 40 cm to the ground plane shall be folded back and forth in the center forming a bundle 30 cm to 40 cm long (see 6.3.1).
4. For emission measurements at or below 1 GHz, the table height shall be 80 cm. For emission measurements above 1 GHz, the table height shall be 1.5 m for measurements, except as otherwise specified (see 6.3.1 and 6.6.3.1).

Diagram 2 Test arrangement for radiated emissions of tabletop equipment

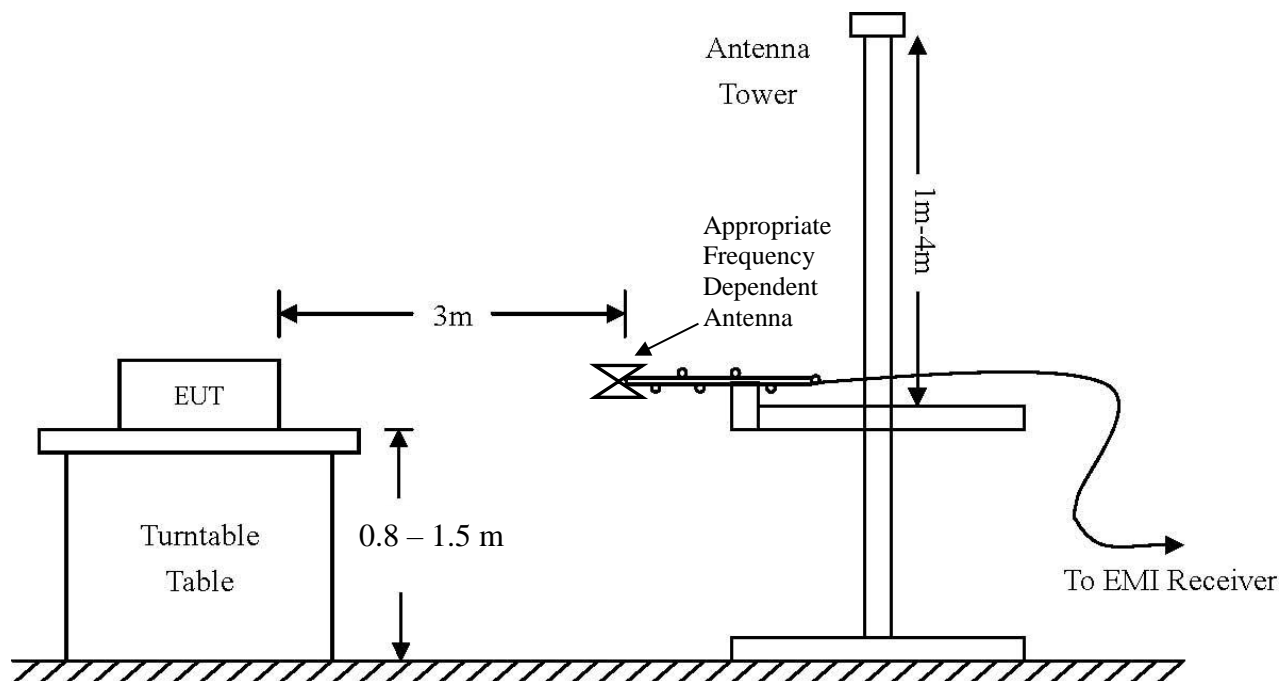

| Frequency: 9 kHz-30 MHz | Frequency: 30 MHz- 1 GHz | Frequency: Above 1 GHz |
|-------------------------|--------------------------|------------------------|
| Loop Antenna | Broadband Biconilog | Horn |
| RBW = 9 kHz | RBW = 120 kHz | RBW = 1 MHz |
| VBW = 30 kHz | VBW = 120 kHz | VBW = 1 MHz |
| Sweep time = Auto | Sweep time = Auto | Sweep time = Auto |
| Detector = PK, QP | Detector = PK, QP | Detector = PK, AV |
| Antenna Height 1m | Antenna Height 1-4m | Antenna Height 1-4m |

Diagram 3 Test arrangement for radiated emissions tested on Open Area Test Site (OATS)

Test Site Locations

Conducted EMI The AC power line conducted emissions testing performed in a shielded screen room located at Rogers Labs, Inc., 4405 W. 259th Terrace, Louisburg, KS

Radiated EMI The radiated emissions tests were performed at the 3 meters, Open Area Test Site (OATS) located at Rogers Labs, Inc., 4405 W. 259th Terrace, Louisburg, KS

Site Registration Refer to Annex for Site Registration Letters

NVLAP Accreditation Lab code 200087-0

List of Test Equipment

A Rohde and Schwarz ESU40 and/or Hewlett Packard 8591EM was used as the measuring device for the emissions testing of frequencies below 1 GHz. A Rohde and Schwarz ESU40 and/or Hewlett Packard 8562A Spectrum Analyzer was used as the measuring device for testing the emissions at frequencies above 1 GHz. The analyzer settings used are described in the following table. Refer to the appendix for a complete list of test equipment.

| AC Line Conducted Emissions (0.150 -30 MHz) | | |
|---|----------|-------------------|
| RBW | AVG. BW | Detector Function |
| 9 kHz | 30 kHz | Peak / Quasi Peak |
| Emissions (30-1000 MHz) | | |
| RBW | AVG. BW | Detector Function |
| 120 kHz | 300 kHz | Peak / Quasi Peak |
| Emissions (Above 1000 MHz) | | |
| RBW | Video BW | Detector Function |
| 100 kHz | 100 kHz | Peak |
| 1 MHz | 1 MHz | Peak / Average |

| Equipment | Manufacturer | Model (SN) | Band | Cal Date | Due |
|---|--------------------|--------------------------------|--------------|----------|-------|
| <input checked="" type="checkbox"/> LISN | FCC | FCC-LISN-50-2-10(1PA) (160611) | .15-30MHz | 6/15 | 5/16 |
| <input checked="" type="checkbox"/> Cable | Time Microwave | 750HF290-750 (L10M) | 9kHz-40 GHz | 10/15 | 10/16 |
| <input checked="" type="checkbox"/> Cable | Belden | RG-58 (L1-CAT3-11509) | 9kHz-30 MHz | 10/15 | 10/16 |
| <input checked="" type="checkbox"/> Cable | Belden | RG-58 (L2-CAT3-11509) | 9kHz-30 MHz | 10/15 | 10/16 |
| <input type="checkbox"/> Antenna | ARA | BCD-235-B (169) | 20-350MHz | 10/15 | 10/16 |
| <input type="checkbox"/> Antenna | EMCO | 3147 (40582) | 200-1000MHz | 10/15 | 10/16 |
| <input checked="" type="checkbox"/> Antenna | ETS-Lindgren | 3117 (200389) | 1-18 GHz | 5/15 | 5/17 |
| <input type="checkbox"/> Antenna | Com Power | AH-118 (10110) | 1-18 GHz | 10/15 | 10/16 |
| <input checked="" type="checkbox"/> Antenna | Com Power | AH-840 (101046) | 18-40 GHz | 5/15 | 5/17 |
| <input checked="" type="checkbox"/> Antenna | EMCO | 6509 (9502-1374) | .001-30 MHz | 10/15 | 10/16 |
| <input checked="" type="checkbox"/> Antenna | Sunol | JB-6 (A100709) | 30-1000 MHz | 10/15 | 10/16 |
| <input type="checkbox"/> Antenna | EMCO | 3143 (9607-1277) | 20-1200 MHz | 5/15 | 5/16 |
| <input type="checkbox"/> Analyzer | HP | 8591EM (3628A00871) | 9kHz-1.8GHz | 5/15 | 5/16 |
| <input type="checkbox"/> Analyzer | HP | 8562A (3051A05950) | 9kHz-110GHz | 5/15 | 5/16 |
| <input type="checkbox"/> Analyzer | HP External Mixers | 11571, 11970 | 25GHz-110GHz | 5/15 | 5/16 |
| <input checked="" type="checkbox"/> Analyzer | Rohde & Schwarz | ESU40 (100108) | 20Hz-40GHz | 5/15 | 5/16 |
| <input checked="" type="checkbox"/> Amplifier | Com-Power | PA-010 (171003) | 100Hz-30MHz | 10/15 | 10/16 |
| <input checked="" type="checkbox"/> Amplifier | Com-Power | CPPA-102 (01254) | 1-1000 MHz | 10/15 | 10/16 |
| <input checked="" type="checkbox"/> Amplifier | Com-Power | PAM-118A (551014) | 0.5-18 GHz | 10/15 | 10/16 |

Rogers Labs, Inc.
 4405 W. 259th Terrace
 Louisburg, KS 66053
 Phone/Fax: (913) 837-3214
 Revision 2

Mikrotikls SIA
 Model: RBmAP L-2nD
 Test #: 150730A-151104
 Test to: 47CFR 15.247, RSS-247
 File: Mikrotikls RBmAPL2ND 150730A r2

S/N: 642A01DDE062
 FCC ID#: TV7MAPL2ND
 IC: 7442A-MAPL2ND
 Date: December 22, 2015

Units of Measurements

Conducted EMI Data is in dB μ V; dB referenced to one microvolt

Radiated EMI Data is in dB μ V/m; dB/m referenced to one microvolt per meter

Sample Calculation:

RFS = Radiated Field Strength, FSM = Field Strength Measured

A.F. = Receive antenna factor, Gain = amplification gains and/or cable losses

RFS (dB μ V/m @ 3m) = FSM (dB μ V) + A.F. (dB) - Gain (dB)

Environmental Conditions

| | |
|----------------------|-----------|
| Ambient Temperature | 23.9° C |
| Relative Humidity | 44% |
| Atmospheric Pressure | 1020.8 mb |

Intentional Radiators

As per 47CFR part 15 subpart C, and Industry Canada RSS-247, Issue 1, the following information is submitted for consideration and demonstration of compliance with regulation and standards.

Antenna Requirements

The EUT incorporates integral antenna system and offers no provision for connection to alternate system. The antenna connection point complies with the unique antenna connection requirements. The requirements of 15.203 are fulfilled; there are no deviations or exceptions to the specification.

Restricted Bands of Operation

Spurious emissions falling in the restricted frequency bands of operation were measured at the antenna port with radiated emissions measured on the OATS. The EUT utilizes frequency, determining circuitry, which generates harmonics falling in restricted bands. Emissions were investigated at the antenna port and OATS, using appropriate antennas or pyramidal horns, amplification stages, and spectrum analyzer. Peak and average amplitudes of frequencies above 1000 MHz were compared to the required limits with worst-case data presented below. Test procedures of ANSI C63.10-2013 were used during testing. No other significant emission was observed which fell into the restricted bands of operation. Computed radiated emission values take into account the measured radiated field strength, receive antenna correction factor, amplifier gain stage, and test system cable losses.

Table 1 General Radiated Emissions in Restricted Bands Data

| Frequency in MHz | Horizontal Peak (dBµV/m) | Horizontal Quasi-Peak (dBµV/m) | Horizontal Average (dBµV/m) | Vertical Peak (dBµV/m) | Vertical Quasi-Peak (dBµV/m) | Vertical Average (dBµV/m) | Limit @ 3m (dBµV/m) |
|------------------|--------------------------|--------------------------------|-----------------------------|------------------------|------------------------------|---------------------------|---------------------|
| 2390.0 | 55.8 | N/A | 44.9 | 43.8 | N/A | 34.9 | 54.0 |
| 2483.5 | 59.0 | N/A | 42.9 | 41.9 | N/A | 28.7 | 54.0 |
| 4824.0 | 51.9 | N/A | 48.6 | 51.7 | N/A | 48.7 | 54.0 |
| 4874.0 | 51.5 | N/A | 47.9 | 51.6 | N/A | 48.0 | 54.0 |
| 4924.0 | 78.5 | N/A | 46.8 | 52.5 | N/A | 47.2 | 54.0 |
| 7236.0 | 46.7 | N/A | 38.7 | 47.0 | N/A | 37.2 | 54.0 |
| 7311.0 | 47.7 | N/A | 34.9 | 48.1 | N/A | 35.2 | 54.0 |
| 7386.0 | 49.3 | N/A | 36.3 | 49.1 | N/A | 36.2 | 54.0 |
| 12060.0 | 51.0 | N/A | 38.4 | 51.1 | N/A | 38.3 | 54.0 |
| 12185.0 | 51.6 | N/A | 38.7 | 51.9 | N/A | 39.8 | 54.0 |
| 12310.0 | 51.8 | N/A | 39.8 | 52.1 | N/A | 39.9 | 54.0 |
| 14472.0 | 52.7 | N/A | 40.1 | 52.9 | N/A | 40.7 | 54.0 |

Other emissions present had amplitudes at least 20 dB below the limit. Peak and Quasi-Peak amplitude emissions are recorded above for frequency range below 1000 MHz. Peak and Average amplitude emissions are recorded above for frequency range above 1000 MHz.

Summary of Results for Radiated Emissions in Restricted Bands

The EUT demonstrated compliance with the emissions requirements of 47CFR 15.205, RSS-GEN and RSS-247, Issue 1 Intentional Radiators. The EUT provided a worst-case minimum margin of -5.3 dB below the emissions requirements in restricted frequency bands. Peak, Quasi-peak, and average amplitudes were checked for compliance with the regulations. Worst-case emissions are reported with other emissions found in the restricted frequency bands at least 20 dB below the requirements.

AC Line Conducted Emissions Procedure

The EUT was arranged in a typical equipment configuration and placed on a 1 x 1.5-meter wooden bench 80 cm above the conducting ground plane, floor of a screen room. The bench was positioned 40 cm away from the wall of the screen room. The LISN was positioned on the floor of the screen room 80-cm from the rear of the EUT. The manufacturer supplied supporting equipment, which provided direct current power to the EUT and was connected to the LISN. A second LISN was positioned on the floor of the screen room 80-cm from the rear of the supporting equipment of the EUT. All power cords except the EUT support equipment power the EUT were then powered from the second LISN. EMI was coupled to the spectrum analyzer through a 0.1 μ F capacitor, internal to the LISN. Power line conducted emissions testing were carried out individually for each current carrying conductor of the EUT support equipment. The excess length of lead between the system and the LISN receptacle was folded back and forth to form a bundle not exceeding 40 cm in length. The screen room, conducting ground plane, analyzer, and LISN were bonded together to the protective earth ground. Preliminary testing was performed to identify the frequency of each emission displaying the highest amplitude. The cables were repositioned to obtain maximum amplitude of measured EMI level. Once the worst-case configuration was identified, plots were made of the EMI from 0.15 MHz to 30 MHz then the data was recorded with maximum conducted emissions levels. Refer to figures one and two for plots of the EUT support equipment AC Line Conducted emissions.

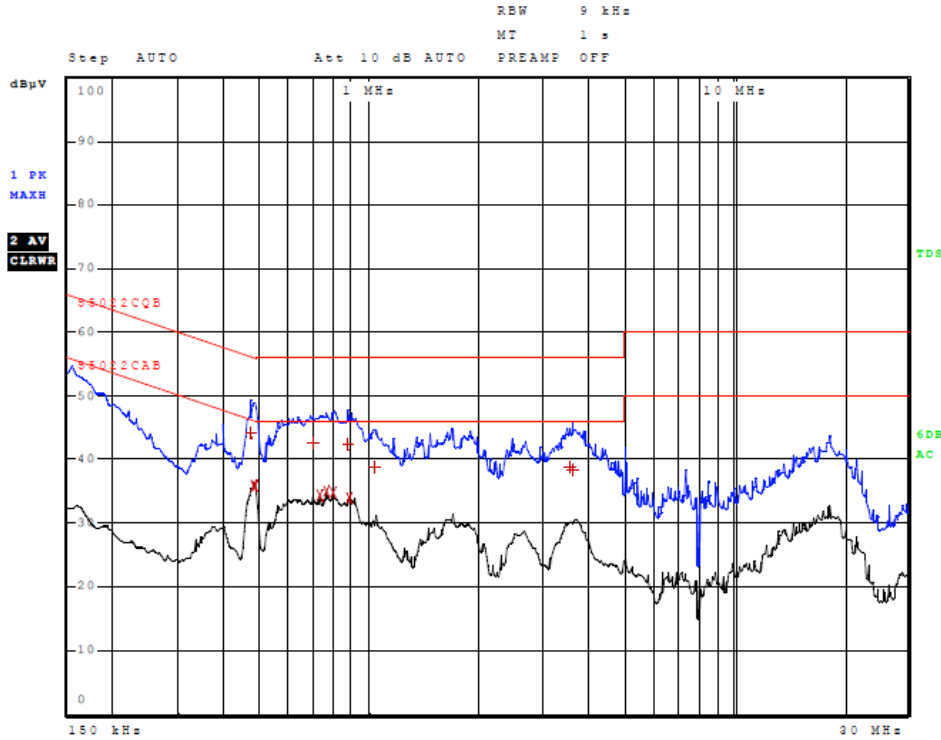

Figure 1 AC Line Conducted Emissions Line 1

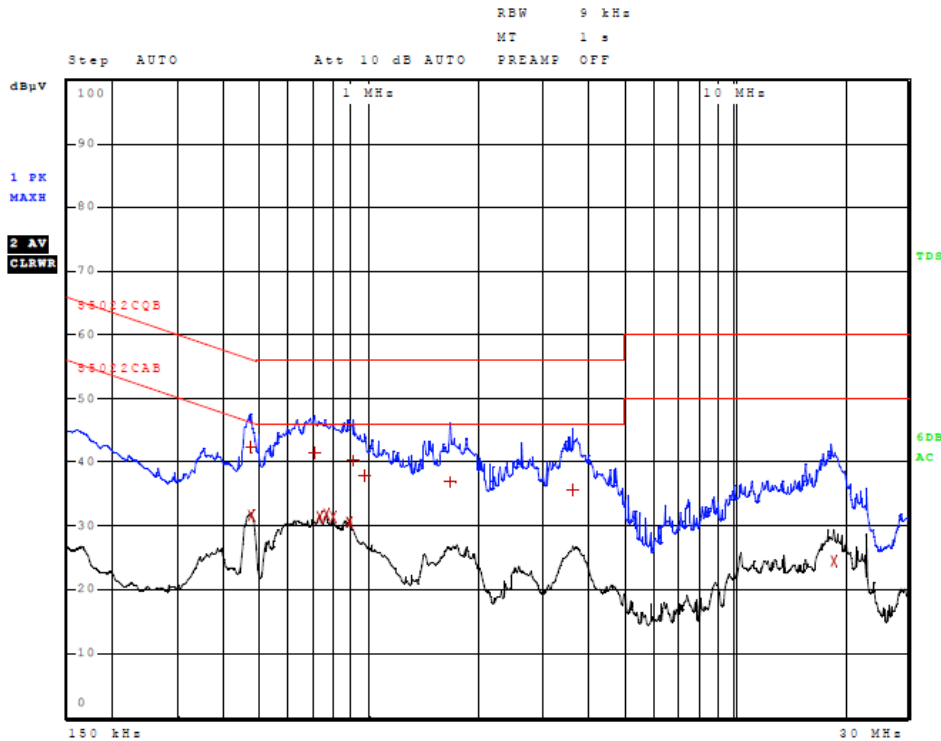

Figure 2 AC Line Conducted Emissions Line 2

Table 2 AC Line Conducted Emissions Data (Highest Emissions Line L1)

| Trace | Frequency | Level (dBµV) | Detector | Delta Limit/dB |
|-------|-------------------|--------------|------------|----------------|
| 1 | 474.000000000 kHz | 44.14 | Quasi Peak | -12.30 |
| 2 | 482.000000000 kHz | 35.82 | Average | -10.48 |
| 2 | 486.000000000 kHz | 35.78 | Average | -10.45 |
| 1 | 702.000000000 kHz | 42.56 | Quasi Peak | -13.44 |
| 2 | 730.000000000 kHz | 34.42 | Average | -11.58 |
| 2 | 762.000000000 kHz | 35.01 | Average | -10.99 |
| 2 | 794.000000000 kHz | 34.69 | Average | -11.31 |
| 1 | 874.000000000 kHz | 42.29 | Quasi Peak | -13.71 |
| 2 | 882.000000000 kHz | 33.87 | Average | -12.13 |
| 1 | 1.038000000 MHz | 38.78 | Quasi Peak | -17.22 |
| 1 | 3.566000000 MHz | 38.67 | Quasi Peak | -17.33 |
| 1 | 3.610000000 MHz | 38.33 | Quasi Peak | -17.67 |

Other emissions present had amplitudes at least 20 dB below the limit.

Table 3 AC Line Conducted Emissions Data (Highest Emissions Line L2)

| Trace | Frequency | Level (dBµV) | Detector | Delta Limit/dB |
|-------|-------------------|--------------|------------|----------------|
| 1 | 470.000000000 kHz | 42.40 | Quasi Peak | -14.11 |
| 2 | 474.000000000 kHz | 31.69 | Average | -14.75 |
| 1 | 706.000000000 kHz | 41.59 | Quasi Peak | -14.41 |
| 2 | 730.000000000 kHz | 31.41 | Average | -14.59 |
| 2 | 762.000000000 kHz | 31.78 | Average | -14.22 |
| 2 | 794.000000000 kHz | 31.33 | Average | -14.67 |
| 2 | 878.000000000 kHz | 30.54 | Average | -15.46 |
| 1 | 902.000000000 kHz | 40.18 | Quasi Peak | -15.82 |
| 1 | 970.000000000 kHz | 37.91 | Quasi Peak | -18.09 |
| 1 | 1.674000000 MHz | 36.88 | Quasi Peak | -19.12 |
| 1 | 3.626000000 MHz | 35.59 | Quasi Peak | -20.41 |
| 2 | 18.780000000 MHz | 24.53 | Average | -25.47 |

Other emissions present had amplitudes at least 20 dB below the limit.

Summary of Results for AC Line Conducted Emissions

The EUT test system demonstrated compliance to the conducted emissions requirements of RSS-210 Issue 8 and RSS-GEN. The EUT demonstrated minimum margin of -10.4 dB below the limit. Measurements were taken using the peak, quasi peak, and average, measurement function for each emissions amplitude and were below the limits stated in the specification. Other emissions were present with recorded data representing worst-case amplitudes.

General Radiated Emissions Procedure

The EUT was arranged in a typical equipment configuration and operated through all available modes with worst-case data recorded. Preliminary testing was performed in a screen room with the EUT positioned 1 meter from the FSM. Radiated emissions measurements were performed to identify the frequencies, which produced the highest emissions. Each radiated emission was then maximized at the OATS location before final radiated emissions measurements were performed. Final data was taken with the EUT located at the OATS at a distance of 3 meters between the EUT and the receiving antenna. The frequency spectrum from 9 kHz to 25,000 MHz was searched for general radiated emissions. Measured emission levels were maximized by EUT placement on the table, rotating the turntable through 360 degrees, varying the antenna height between 1 and 4 meters above the ground plane and changing antenna position between horizontal and vertical polarization. Antennas used were Loop from 9 kHz to 30 MHz, Broadband Biconical from 30 to 200 MHz, Biconilog from 30 to 1000 MHz, Log Periodic from 200 MHz to 1 GHz and or Double Ridge or pyramidal horns and mixers from 1 GHz to 25 GHz, notch filters, and appropriate amplifiers and external mixers were utilized.

Table 4 General Radiated Emissions from EUT Data (Highest Emissions)

| Frequency in MHz | Horizontal Peak (dBµV/m) | Horizontal Quasi-Peak (dBµV/m) | Horizontal Average (dBµV/m) | Vertical Peak (dBµV/m) | Vertical Quasi-Peak (dBµV/m) | Vertical Average (dBµV/m) | Limit @ 3m (dBµV/m) |
|------------------|--------------------------|--------------------------------|-----------------------------|------------------------|------------------------------|---------------------------|---------------------|
| 48.6 | 31.3 | 25.7 | N/A | 32.7 | 28.2 | N/A | 40.0 |
| 178.2 | 28.7 | 22.7 | N/A | 25.4 | 20.5 | N/A | 43.5 |
| 179.1 | 29.0 | 23.7 | N/A | 26.2 | 20.6 | N/A | 43.5 |
| 180.3 | 29.2 | 24.3 | N/A | 25.9 | 20.4 | N/A | 43.5 |
| 218.6 | 38.4 | 34.3 | N/A | 31.4 | 26.9 | N/A | 43.5 |
| 220.2 | 37.6 | 34.1 | N/A | 32.7 | 28.6 | N/A | 46.0 |
| 220.3 | 37.3 | 32.5 | N/A | 32.3 | 28.1 | N/A | 46.0 |
| 223.5 | 36.0 | 31.9 | N/A | 33.7 | 29.0 | N/A | 46.0 |
| 225.1 | 38.2 | 34.0 | N/A | 31.7 | 29.0 | N/A | 46.0 |
| 235.7 | 33.7 | 28.2 | N/A | 33.8 | 29.1 | N/A | 46.0 |
| 249.2 | 38.0 | 34.3 | N/A | 32.5 | 29.3 | N/A | 46.0 |
| 253.8 | 36.4 | 32.2 | N/A | 34.7 | 31.1 | N/A | 46.0 |
| 261.9 | 32.8 | 27.1 | N/A | 34.2 | 30.0 | N/A | 46.0 |
| 268.3 | 32.9 | 27.6 | N/A | 36.2 | 29.6 | N/A | 46.0 |

Other emissions present had amplitudes at least 20 dB below the limit. Peak and Quasi-Peak amplitude emissions are recorded above for frequency range below 1000 MHz. Peak and Average amplitude emissions are recorded above for frequency range above 1000 MHz.

Summary of Results for General Radiated Emissions

The EUT demonstrated compliance with the radiated emissions requirements of 47CFR part 15 and Industry Canada RSS-247 Issue 1 Intentional Radiators. The EUT demonstrated a minimum margin of -9.2 dB below the requirements. Other emissions were present with amplitudes at least 20 dB below the Limits.

Operation in the 2400-2483.5 MHz Frequency Band

Radiated emissions were measured on the Open Area Test Site (OATS) at a three-meter distance. The EUT utilizes permanently attached printed circuit board antenna. The EUT was placed on a turntable elevated as required above the ground plane at a distance of 3 meters from the FSM antenna located on the OATS. The table permitted orientation of the EUT in each of three orthogonal axis positions during testing. The peak and quasi-peak amplitude of the frequencies below 1000 MHz were measured using a spectrum analyzer. The peak and average amplitude of emissions above 1000 MHz were measured using a spectrum analyzer. Emissions data was recorded from the measurement results. Data presented reflects measurement result corrected to account for measurement system gains and losses. Plots were made of transmitter performance for reference purposes. Refer to figures three through eleven showing plots of the EUT performance displaying compliance with the specifications.

This product utilizes permanently attached antenna system and offers no provision for antenna port conducted measurements. As such, the testing procedures as defined in publications KDB 558074 D01 DTS Meas Guidance v03r03, KDB 662911 D02, and ANSI C63.10-2013 were utilized during compliance testing. These procedures provide for antenna port measurement or measurement of maximum field strength and conversion calculations for comparison with requirements.

1. The transmitter's peak power was measured as specified in 9.1.2 of KDB 558074
2. Emission DTS Bandwidth was measured in compliance with KDB 558074 paragraph 8.
3. Maximum Power Spectral Density was measured in compliance with KDB 662911 paragraph 10.
4. Unwanted Radiated Emissions were measured in compliance with KDB 558074 paragraph 11 and specified in ANSI C63-10 at a 3-meters distance located on the OATS.
5. Radiated Emissions Levels in restricted bands were measured in compliance with KDB 558074 paragraph 12, specified in ANSI C63-10 at a 3-meters distance located on the OATS.
6. Band-Edge measurements were performed in compliance with KDB 558074 paragraph 13 and specified in ANSI C63-10.

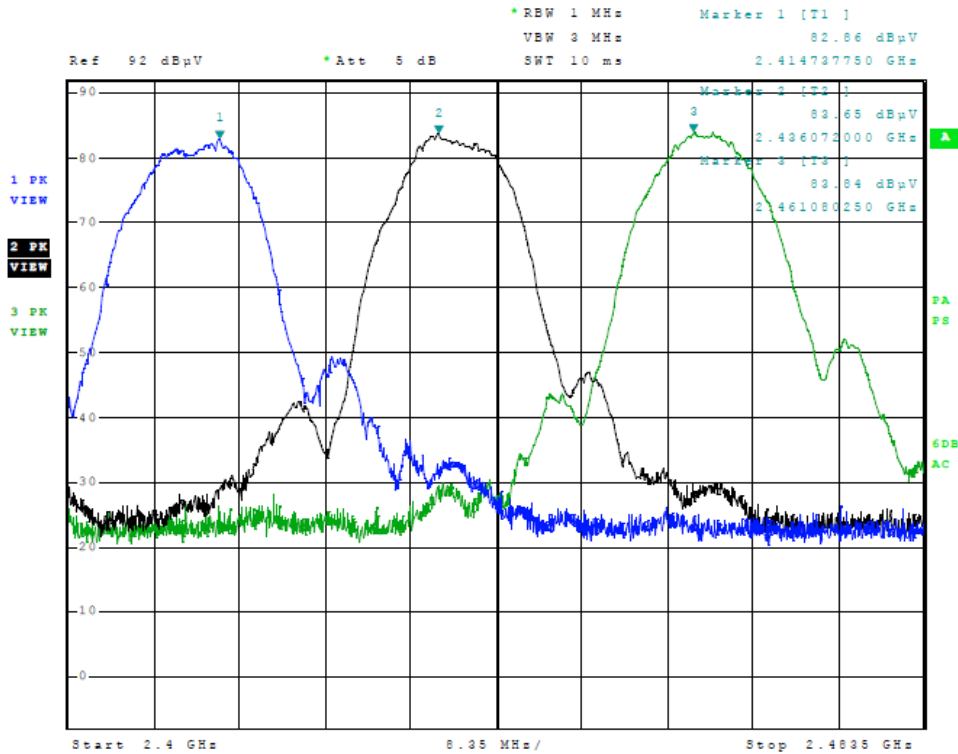

Figure 3 Plot of Transmitter Emissions (Across Operational Band 802.11b)

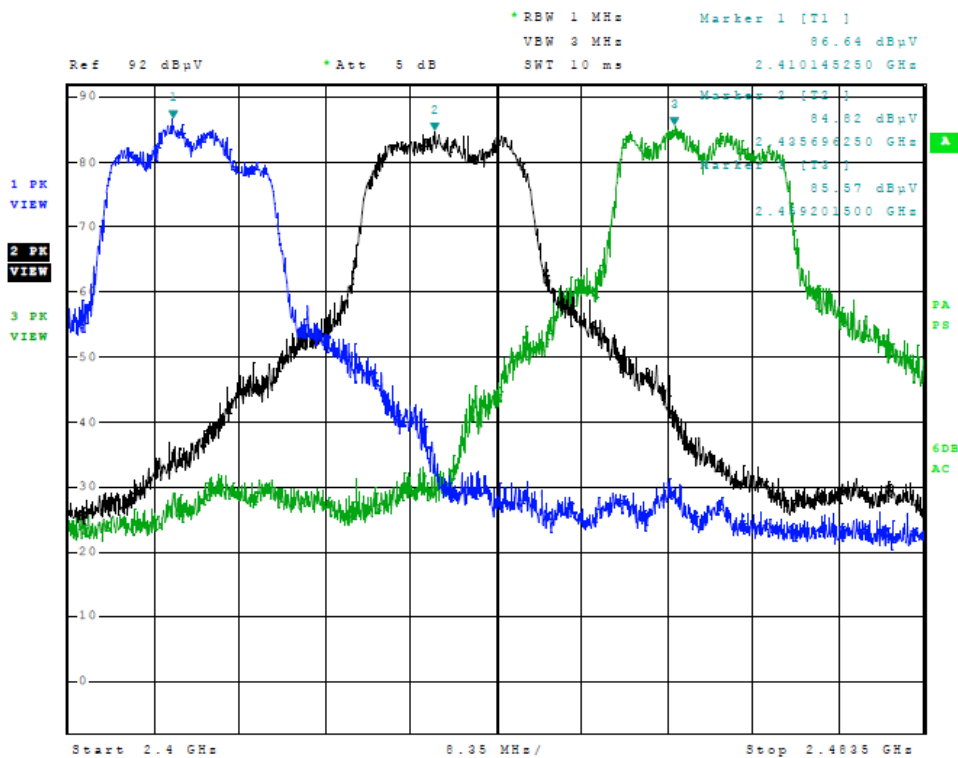

Figure 4 Plot of Transmitter Emissions (Across Operational Band, 802.11g)

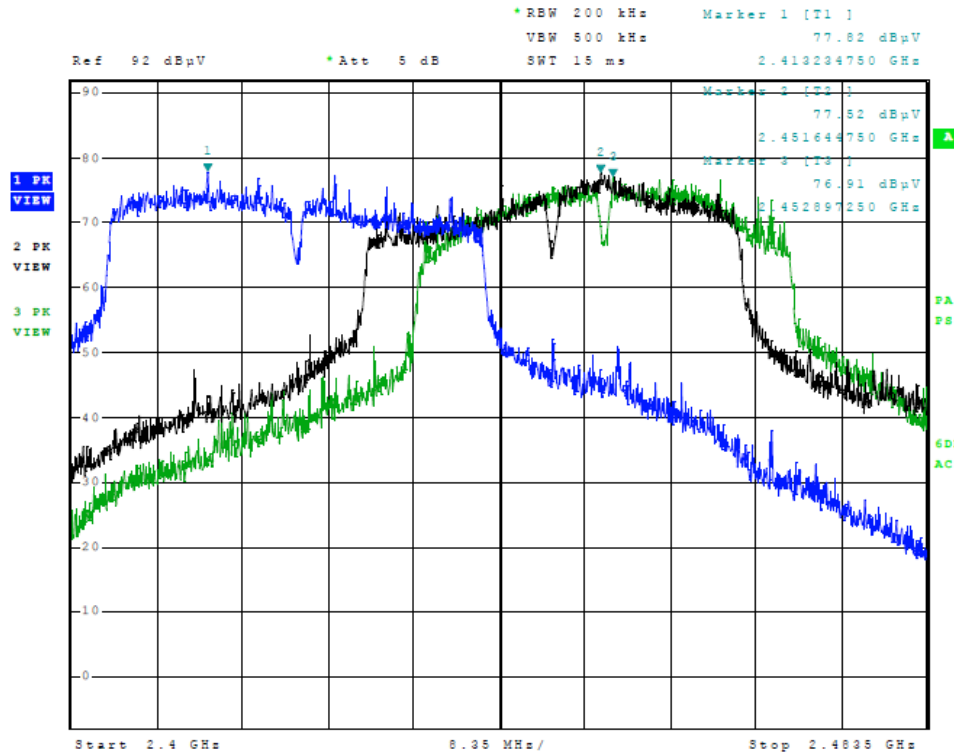

Figure 5 Plot of Transmitter Emissions (Across Operational Band, 802.11n)

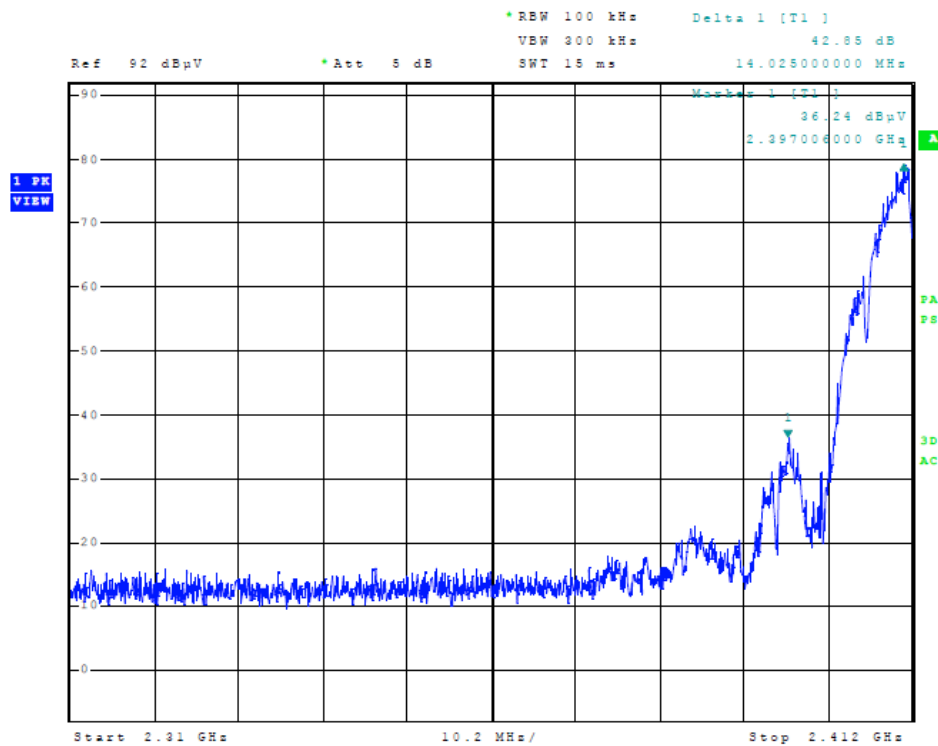

Figure 6 Plot of Transmitter Low Band Edge (802.11b)

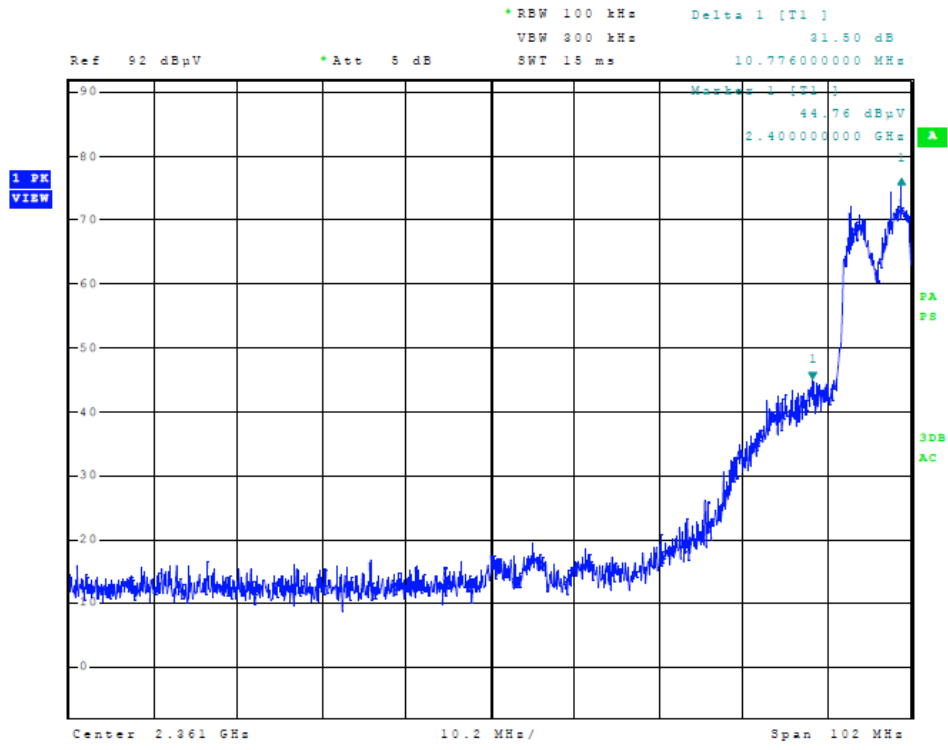

Figure 7 Plot of Transmitter Low Band Edge (802.11g)

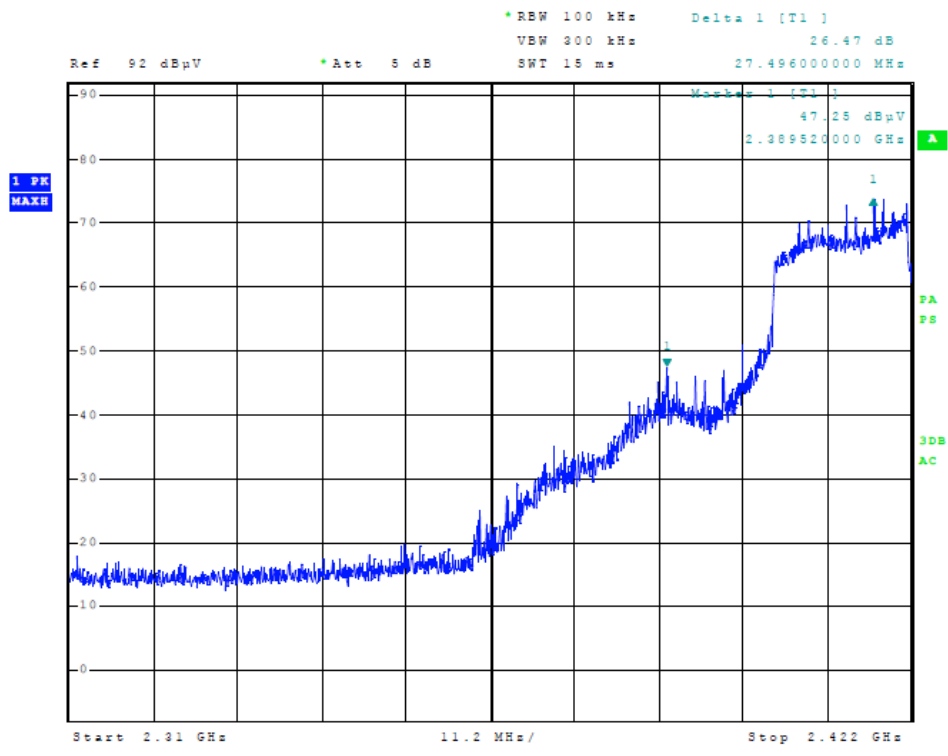

Figure 8 Plot of Transmitter Low Band Edge (802.11n)

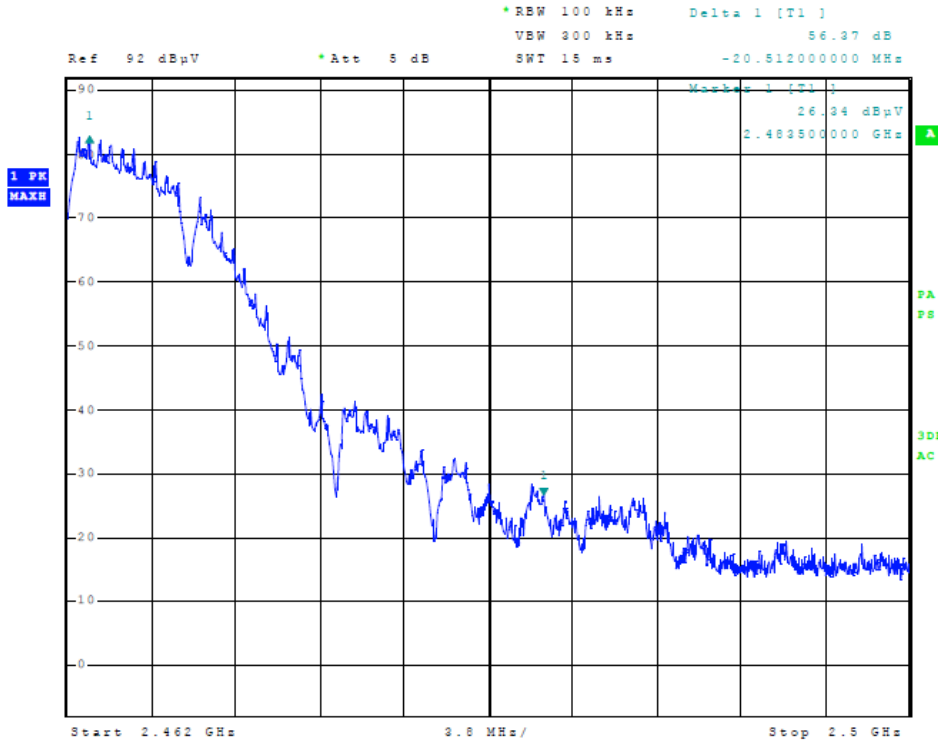

Figure 9 Plot of Transmitter High Band Edge (802.11b)

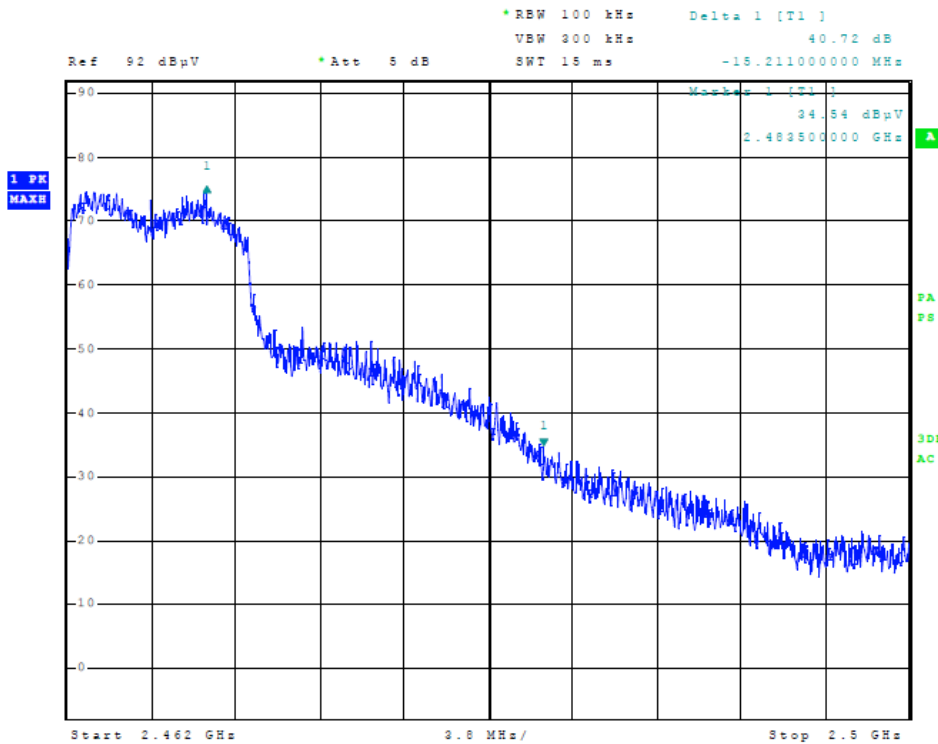

Figure 10 Plot of Transmitter High Band Edge (802.11g)

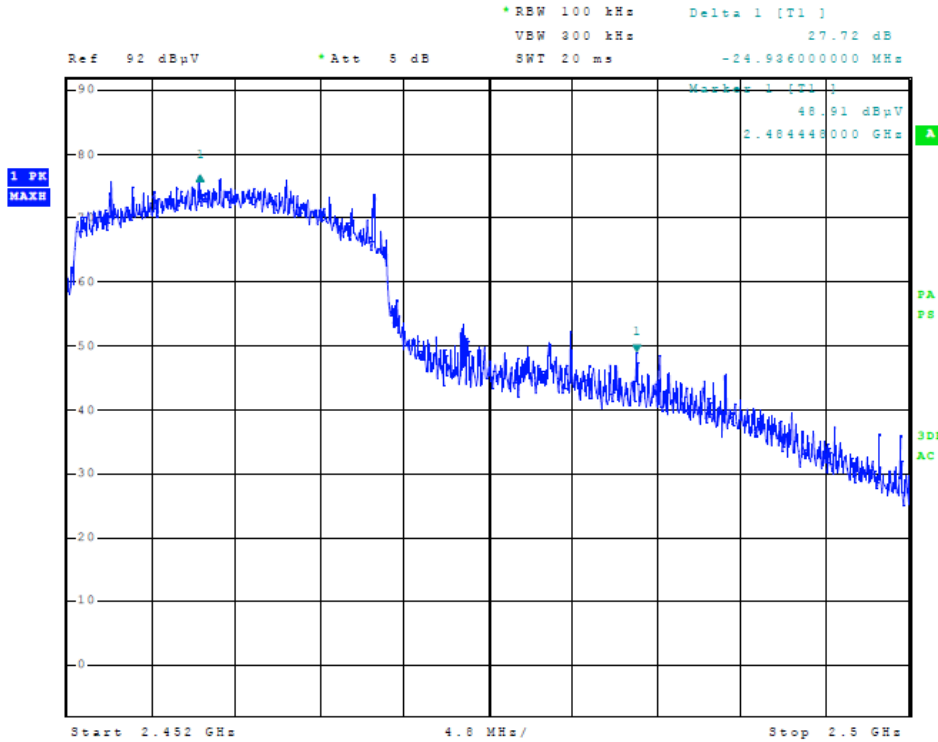

Figure 11 Plot of Transmitter High Band Edge (802.11n)

Transmitter Emissions Data

Table 5 Transmitter Power and Emissions

| Frequency MHz | Calculated Conducted Antenna Port Output Power (Watts) | 6-dB Occupied Bandwidth kHz | Calculated Power Spectral Density dBm |
|---------------|--|-----------------------------|---------------------------------------|
| 20 MHz Mode | | | |
| 2412.0 | 0.161 | 16,860 | -7.89 |
| 2437.0 | 0.157 | 16,860 | -8.01 |
| 2462.0 | 0.154 | 16,860 | -8.15 |
| 40 MHz Mode | | | |
| 2422.0 | 0.108 | 36,300 | -10.77 |
| 2447.0 | 0.108 | 36,480 | -10.58 |
| 2452.0 | 0.107 | 36,300 | -10.72 |

Table 6 Transmitter Radiated Emission

| Frequency in MHz | Horizontal Peak (dBµV/m) | Horizontal Average (dBµV/m) | Vertical Peak (dBµV/m) | Vertical Average (dBµV/m) | Limit @ 3m (dBµV/m) |
|------------------|--------------------------|-----------------------------|------------------------|---------------------------|---------------------|
| 2412.0 | 104.3 | 98.1 | 99.3 | 91.3 | -- |
| 4824.0 | 51.9 | 48.6 | 51.7 | 48.7 | 54.0 |
| 7236.0 | 46.7 | 38.7 | 47.0 | 37.2 | 54.0 |
| 9648.0 | 47.5 | 35.4 | 47.4 | 35.3 | 54.0 |
| 12060.0 | 51.0 | 38.4 | 51.1 | 38.3 | 54.0 |
| 14472.0 | 52.7 | 40.1 | 52.9 | 40.7 | 54.0 |
| 16884.0 | 56.3 | 44.3 | 56.4 | 44.4 | 54.0 |
| 2437.0 | 104.2 | 98.0 | 99.2 | 91.1 | -- |
| 4874.0 | 51.5 | 47.9 | 51.6 | 48.0 | 54.0 |
| 7311.0 | 47.7 | 34.9 | 48.1 | 35.2 | 54.0 |
| 9748.0 | 50.3 | 38.8 | 50.1 | 38.4 | 54.0 |
| 12185.0 | 51.6 | 38.7 | 51.9 | 39.8 | 54.0 |
| 14622.0 | 53.8 | 41.1 | 54.1 | 42.5 | 54.0 |
| 17059.0 | 57.0 | 44.5 | 58.0 | 45.0 | 54.0 |
| 2462.0 | 104.1 | 97.8 | 98.7 | 90.8 | -- |
| 4924.0 | 78.5 | 46.8 | 52.5 | 47.2 | 54.0 |
| 7386.0 | 49.3 | 36.3 | 49.1 | 36.2 | 54.0 |
| 9848.0 | 47.2 | 35.7 | 47.2 | 34.8 | 54.0 |
| 12310.0 | 51.8 | 39.8 | 52.1 | 39.9 | 54.0 |
| 14772.0 | 54.0 | 41.2 | 54.2 | 41.4 | 54.0 |
| 17234.0 | 58.2 | 45.2 | 58.1 | 45.1 | 54.0 |

Other emissions present had amplitudes at least 20 dB below the limit. Peak and Quasi-Peak amplitude emissions are recorded above for frequency range of 30-1000 MHz. Peak and Average amplitude emissions are recorded above for frequency range above 1000 MHz.

Summary of Results for Transmitter Radiated Emissions of Intentional Radiator

The EUT demonstrated compliance with the radiated emissions requirements of 47CFR Part 15.247 and Industry Canada RSS-247. The calculated peak power was 0.161 watts total power. The worst-case total peak power spectral density provided a minimum margin of -15.9 dB below the requirements. The minimum margin harmonic radiated emission provided -5.3 dB margin below requirements. General radiated emissions of supporting equipment provided -9.2 dB margin. There were no other significantly measurable emissions in the restricted bands other than those recorded in this report. Other emissions were present with amplitudes at least 20 dB below the requirements. There were no other deviations or exceptions to the requirements.

Statement of Modifications and Deviations

No modifications to the EUT were required for the unit to demonstrate compliance with the 47CFR Part 15C and Industry Canada RSS-247 emissions requirements. There were no deviations or modifications to the specifications.

Annex

- Annex A Measurement Uncertainty Calculations
- Annex B Rogers Labs Test Equipment List
- Annex C Rogers Qualifications
- Annex D FCC Site Registration Letter
- Annex E Industry Canada Site Registration Letter

Annex A Measurement Uncertainty Calculations

Measurement uncertainty calculations were made for the laboratory. Result of measurement uncertainty calculations are recorded below for AC line conducted and radiated emission measurements.

| Measurement Uncertainty | $U_{(E)}$ | $U_{(lab)}$ |
|---|-----------|-------------|
| 3 Meter Horizontal 30-200 MHz Measurements | 2.08 | 4.16 |
| 3 Meter Vertical 30-200 MHz Measurements | 2.16 | 4.33 |
| 3 Meter Vertical Measurements 200-1000 MHz | 2.99 | 5.97 |
| 10 Meter Horizontal Measurements 30-200 MHz | 2.07 | 4.15 |
| 10 Meter Vertical Measurements 30-200 MHz | 2.06 | 4.13 |
| 10 Meter Horizontal Measurements 200-1000 MHz | 2.32 | 4.64 |
| 10 Meter Vertical Measurements 200-1000 MHz | 2.33 | 4.66 |
| 3 Meter Measurements 1-6 GHz | 2.57 | 5.14 |
| 3 Meter Measurements 6-18 GHz | 2.58 | 5.16 |
| AC Line Conducted | 1.72 | 3.43 |

Annex B Rogers Labs Test Equipment List

| List of Test Equipment | Calibration | Date | Due |
|--|-------------|-------|-------|
| Spectrum Analyzer: Rohde & Schwarz ESU40 | | 5/15 | 5/16 |
| Spectrum Analyzer: HP 8562A, HP Adapters: 11518, 11519, and 11520 | | 5/15 | 5/16 |
| Mixers: 11517A, 11970A, 11970K, 11970U, 11970V, 11970W | | | |
| Spectrum Analyzer: HP 8591EM | | 5/15 | 5/16 |
| Antenna: EMCO Biconilog Model: 3143 | | 5/15 | 5/16 |
| Antenna: Sunol Biconilog Model: JB6 | | 10/15 | 10/16 |
| Antenna: EMCO Log Periodic Model: 3147 | | 10/15 | 10/16 |
| Antenna: Com Power Model: AH-118 | | 10/15 | 10/16 |
| Antenna: Com Power Model: AH-840 | | 5/15 | 5/17 |
| Antenna: Antenna Research Biconical Model: BCD 235 | | 10/15 | 10/16 |
| Antenna: EMCO 6509 | | 10/15 | 10/16 |
| LISN: Compliance Design Model: FCC-LISN-2.Mod.cd, 50 µHy/50 ohm/0.1 µf | | 10/15 | 10/16 |
| R.F. Preamp CPPA-102 | | 10/15 | 10/16 |
| Attenuator: HP Model: HP11509A | | 10/15 | 10/16 |
| Attenuator: Mini Circuits Model: CAT-3 | | 10/15 | 10/16 |
| Attenuator: Mini Circuits Model: CAT-3 | | 10/15 | 10/16 |
| Cable: Belden RG-58 (L1) | | 10/15 | 10/16 |
| Cable: Belden RG-58 (L2) | | 10/15 | 10/16 |
| Cable: Belden 8268 (L3) | | 10/15 | 10/16 |
| Cable: Time Microwave: 4M-750HF290-750 | | 10/15 | 10/16 |
| Cable: Time Microwave: 10M-750HF290-750 | | 10/15 | 10/16 |
| Frequency Counter: Leader LDC825 | | 2/15 | 2/16 |
| Oscilloscope Scope: Tektronix 2230 | | 2/15 | 2/16 |
| Wattmeter: Bird 43 with Load Bird 8085 | | 2/15 | 2/16 |
| Power Supplies: Sorensen SRL 20-25, SRL 40-25, DCR 150, DCR 140 | | 2/15 | 2/16 |
| R.F. Generators: HP 606A, HP 8614A, HP 8640B | | 2/15 | 2/16 |
| R.F. Power Amp 65W Model: 470-A-1010 | | 2/15 | 2/16 |
| R.F. Power Amp 50W M185- 10-501 | | 2/15 | 2/16 |
| R.F. Power Amp A.R. Model: 10W 1010M7 | | 2/15 | 2/16 |
| R.F. Power Amp EIN Model: A301 | | 2/15 | 2/16 |
| LISN: Compliance Eng. Model 240/20 | | 2/15 | 2/16 |
| LISN: Fischer Custom Communications Model: FCC-LISN-50-16-2-08 | | 2/15 | 2/16 |
| Antenna: EMCO Dipole Set 3121C | | 2/15 | 2/16 |
| Antenna: C.D. B-101 | | 2/15 | 2/16 |
| Antenna: Solar 9229-1 & 9230-1 | | 2/15 | 2/16 |
| Audio Oscillator: H.P. 201CD | | 2/15 | 2/16 |
| ELGAR Model: 1751 | | 2/15 | 2/16 |
| ELGAR Model: TG 704A-3D | | 2/15 | 2/16 |
| ESD Test Set 2010i | | 2/15 | 2/16 |
| Fast Transient Burst Generator Model: EFT/B-101 | | 2/15 | 2/16 |
| Field Intensity Meter: EFM-018 | | 2/15 | 2/16 |
| KEYTEK Ecat Surge Generator | | 2/15 | 2/16 |
| Shielded Room 5 M x 3 M x 3.0 M | | | |

Annex C Rogers Qualifications

Scot D. Rogers, Engineer

Rogers Labs, Inc.

Mr. Rogers has approximately 17 years' experience in the field of electronics. Engineering experience includes six years in the automated controls industry and remaining years working with the design, development and testing of radio communications and electronic equipment.

Positions Held

Systems Engineer: A/C Controls Mfg. Co., Inc. 6 Years

Electrical Engineer: Rogers Consulting Labs, Inc. 5 Years

Electrical Engineer: Rogers Labs, Inc. Current

Educational Background

- 1) Bachelor of Science Degree in Electrical Engineering from Kansas State University.
- 2) Bachelor of Science Degree in Business Administration Kansas State University.
- 3) Several Specialized Training courses and seminars pertaining to Microprocessors and Software programming.

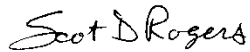

Scot D. Rogers

Annex D FCC Site Registration Letter

FEDERAL COMMUNICATIONS COMMISSION

**Laboratory Division
7435 Oakland Mills Road
Columbia, MD 21046**

April 16, 2015

Registration Number: 90910

Rogers Labs, Inc.
4405 West 259th Terrace
Louisburg, KS 66053

Attention: Scot Rogers,

Re: Measurement facility located at Louisburg
3 & 10 meter site
Date of Renewal: April 16, 2015

Dear Sir or Madam:

Your request for renewal of the registration of the subject measurement facility has been received. The information submitted has been placed in your file and the registration has been renewed. The name of your organization will remain on the list of facilities whose measurement data will be accepted in conjunction with applications for Certification under Parts 15 or 18 of the Commission's Rules. Please note that the file must be updated for any changes made to the facility and the registration must be renewed at least every three years.

Measurement facilities that have indicated that they are available to the public to perform measurement services on a fee basis may be found on the FCC website www.fcc.gov under E-Filing, OET Equipment Authorization Electronic Filing, Test Firms.

Sincerely,

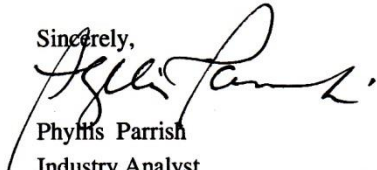
Phyllis Parrish
Industry Analyst

Rogers Labs, Inc.
4405 W. 259th Terrace
Louisburg, KS 66053
Phone/Fax: (913) 837-3214
Revision 2

Mikrotikls SIA
Model: RBmAP L-2nD
Test #: 150730A-151104
Test to: 47CFR 15.247, RSS-247
File: Mikrotikls RBmAPL2ND 150730A r2

S/N: 642A01DDE062
FCC ID#: TV7MAPL2ND
IC: 7442A-MAPL2ND
Date: December 22, 2015

Page 32 of 33

Annex E Industry Canada Site Registration Letter

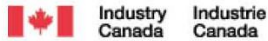

June 08, 2015

OUR FILE: 46405-3041
Authorization No: 010277847-001

Rogers Labs Inc.
4405 West 259th Terrace
Louisburg, KS
USA
66053

Attention: Mr. Scot D. Rogers

Dear Sir:

The Bureau has received your application for the renewal of 3m OATS. Be advised that the information received was satisfactory to Industry Canada. The following number(s) is now associated to the site(s) for which registration / renewal was sought (**Site# 3041A-1**). Please reference the appropriate site number in the body of test reports containing measurements performed on the site. In addition, please keep for your records the following information;

- The company address code associated to the site(s) located at the above address is: **3041A**

Furthermore, to obtain or renew a unique site number, the applicant shall demonstrate that the site has been accredited to ANSI C63.4-2009 or later. A scope of accreditation indicating the accreditation by a recognized accreditation body to ANSI C63.4-2009 or later shall be accepted. Please indicate in a letter the previous assigned site number if applicable and the type of site (example: 3 metre OATS or 3 metre chamber). If the test facility is not accredited to ANSI C63.4-2009 or later, the test facility shall submit test data demonstrating full compliance with the ANSI standard. The Bureau will evaluate the filing to determine if recognition shall be granted.

The frequency for re-validation of the test site and the information that is required to be filed or retained by the testing party shall comply with the requirements established by the accrediting organization. However, in all cases, test site re-validation shall occur on an interval not to exceed **three years**. There is no fee or form associated with an OATS filing. OATS submissions are encouraged to be submitted electronically to the Bureau using the following URL; http://strategis.ic.gc.ca/epic/internet/inceb-bhst.nsf/en/h_tt00052e.html.

If you have any questions, you may contact the Bureau by e-mail at certification.bureau@ic.gc.ca Please reference our file and submission number above for all correspondence.

Yours sincerely,

A handwritten signature in black ink, appearing to read "Bill Payn".

Bill Payn
For: Wireless Laboratory Manager
Certification and Engineering Bureau
3701 Carling Ave., Building 94
P.O. Box 11490, Station AH@
Ottawa, Ontario K2H 8S2
Email: certification.bureau@ic.gc.ca

Rogers Labs, Inc.
4405 W. 259th Terrace
Louisburg, KS 66053
Phone/Fax: (913) 837-3214
Revision 2

Mikrotikls SIA
Model: RBmAP L-2nD
Test #: 150730A-151104
Test to: 47CFR 15.247, RSS-247
File: Mikrotikls RBmAPL2ND 150730A r2

S/N: 642A01DDE062
FCC ID#: TV7MAPL2ND
IC: 7442A-MAPL2ND
Date: December 22, 2015

Page 33 of 33