

Test of: MikroTik RBSXTsqG-5acD

To: FCC CFR 47 Part 15B; ICES-003 Issue 6:
2016

Test Report Serial No.: MIKO60-U13 Rev A



TEST REPORT
FROM



Test of: MikroTik RBSXTsqG-5acD

To: FCC CFR 47 Part 15B & IC ICES-003

Test Report Serial No.: MIKO60-U13 Rev A

This report supersedes: NONE

Manufacturer: MikroTik
Pernavas 46
Riga, LV 1009
Latvia

Product Function: 802.11 ac WLAN Access point

Copy No: pdf Issue Date: 1st August 2017

This Test Report is Issued Under the Authority of:

MiCOM Labs, Inc.
575 Boulder Court,
Pleasanton, CA 94566 USA
Phone: +1 (925) 462-0304
Fax: +1 (925) 462-0306
www.micomlabs.com



TESTING CERT #2381.01

MiCOM Labs is an ISO 17025 Accredited Testing Laboratory



Title: MikroTik RBSXTsqG-5acD
To: FCC CFR 47 Part 15B & IC ICES-003
Serial #: MIKO60-U13 Rev A
Date: 1st August 2017
Page: 3 of 37

This page has been left intentionally blank

This test report may be reproduced in full only. The document may only be updated by MiCOM Labs personnel and any changes noted in the Document History section of the report.

TABLE OF CONTENTS

1.	ACCREDITATION, LISTINGS & RECOGNITION	5
1.1.	Test Accreditation.....	5
1.2.	Recognition	6
1.3.	Product Certification	7
2.	DOCUMENT HISTORY	8
3.	TEST RESULT CERTIFICATE	9
4.	REFERENCES AND MEASUREMENT UNCERTAINTY	10
4.1.	Normative References.....	10
4.2.	Test and Uncertainty Procedures	11
5.	TEST SUMMARY	12
6.	PRODUCT DETAILS AND TEST CONFIGURATIONS	13
6.1.	Test Program Scope	13
6.2.	EUT Details	16
6.3.	External A.C/D.C. Power Adaptor.....	17
6.4.	Antenna Details.....	17
6.5.	Cabling and I/O Ports	17
6.6.	Equipment Details	17
6.7.	Equipment Modifications	18
6.8.	Deviations from the Test Standard	18
6.9.	EUT Configurations	19
6.9.1.	<i>EUT Configuration - Radiated Emissions:</i>	19
7.	TEST RESULTS	21
7.1.	EMC EMISSIONS TEST RESULTS	21
7.1.1.	<i>Radiated Emissions</i>	21
7.1.2.	<i>AC Mains Power Input/Output Ports</i>	28
8.	PHOTOGRAPHS	33
8.1.	Radio Emissions Front	33
8.2.	Radiated Emissions Back.....	34
8.1.	AC Wireline Emissions	35

This test report may be reproduced in full only. The document may only be updated by MiCOM Labs personnel and any changes noted in the Document History section of the report.

1. ACCREDITATION, LISTINGS & RECOGNITION

1.1. Test Accreditation

MiCOM Labs, Inc. an accredited laboratory complies with the international standard EN ISO/IEC 17025. The company is accredited by the American Association for Laboratory Accreditation (A2LA) www.a2la.org test laboratory number 2381.01. MiCOM Labs test schedule is available at the following URL; <http://www.a2la.org/scopepdf/2381-01.pdf>



Accredited Laboratory

A2LA has accredited

MICOM LABS

Pleasanton, CA

for technical competence in the field of

Electrical Testing

This laboratory is accredited in accordance with the recognized International Standard ISO/IEC 17025:2005 General requirements for the competence of testing and calibration laboratories. This accreditation demonstrates technical competence for a defined scope and the operation of a laboratory quality management system (refer to joint ISO-ILAC-IAF Communiqué dated 8 January 2009).



Presented this 4th day of February 2016.

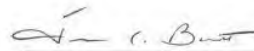

Senior Director of Quality & Communications
For the Accreditation Council
Certificate Number 2381.01
Valid to November 30, 2017

For the tests or types of tests to which this accreditation applies, please refer to the laboratory's Electrical Scope of Accreditation.

This test report may be reproduced in full only. The document may only be updated by MiCOM Labs personnel and any changes noted in the Document History section of the report.



1.2. Recognition

MiCOM Labs, Inc has widely recognized Electrical testing capabilities. Our international recognition includes Conformity Assessment Body designation by APEC MRA** countries. Our test reports are widely accepted for global type approvals.

Country	Recognition Body	Status	Phase	Identification No.
model	Federal Communications Commission (FCC)	TCB	-	US0159 Listing #: 102167
Canada	Industry Canada (IC)	FCB	APEC MRA 2	US0159 Listing #: 4143A-2 4143A-3
Japan	MIC (Ministry of Internal Affairs and Communication)	CAB	APEC MRA 2	RCB 210
	VCCI	--	--	A-0012
Europe	European Commission	NB	EU MRA	NB 2280
Australia	Australian Communications and Media Authority (ACMA)	CAB	APEC MRA 1	US0159
Hong Kong	Office of the Telecommunication Authority (OFTA)	CAB	APEC MRA 1	
Korea	Ministry of Information and Communication Radio Research Laboratory (RRL)	CAB	APEC MRA 1	
Singapore	Infocomm Development Authority (IDA)	CAB	APEC MRA 1	
Taiwan	National Communications Commission (NCC) Bureau of Standards, Metrology and Inspection (BSMI)	CAB	APEC MRA 1	
Vietnam	Ministry of Communication (MIC)	CAB	APEC MRA 1	

**APEC MRA – Asia Pacific Economic Community Mutual Recognition Agreement.

Is a recognition agreement under which test lab is accredited to regulatory standards of the APEC member countries

Phase I - recognition for product testing

Phase II – recognition for both product testing and certification

N/A – Not Applicable

**EU MRA – European Union Mutual Recognition Agreement.

Is a recognition agreement under which test lab is accredited to regulatory standards of the EU member countries

**NB – Notified Body

This test report may be reproduced in full only. The document may only be updated by MiCOM Labs personnel and any changes noted in the Document History section of the report.

1.3. Product Certification

MiCOM Labs, Inc. is an accredited Product Certification Body per the international standard ISO/IEC 17065. The company is accredited by the American Association for Laboratory Accreditation (A2LA) www.a2la.org test laboratory number 2381.02. MiCOM Labs test schedule is available at the following URL; <http://www.a2la.org/scopepdf/2381-02.pdf>



Accredited Product Certification Body

A2LA has accredited

MICOM LABS

Pleasanton, CA

This product certification body is accredited in accordance with the recognized International Standard ISO/IEC 17065:2012 *Requirements for bodies certifying products, processes and services*. This accreditation demonstrates technical competence for a defined scope and the operation of a management system.



Presented this 4th day of February 2016.

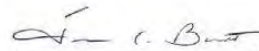

Senior Director of Quality & Communications
For the Accreditation Council
Certificate Number 2381.02
Valid to November 30, 2017

For the product certification schemes to which this accreditation applies, please refer to the organization's Product Certification Scope of Accreditation.

United States of America – Telecommunication Certification Body (TCB)

TCB Identifier – US0159

Industry Canada – Certification Body

CAB Identifier – US0159

Europe – Notified Body

Notified Body Identifier - 2280

Japan – Recognized Certification Body (RCB)

RCB Identifier – 210

This test report may be reproduced in full only. The document may only be updated by MiCOM Labs personnel and any changes noted in the Document History section of the report.



Title: MikroTik RBSXTsqG-5acD
To: FCC CFR 47 Part 15B & IC ICES-003
Serial #: MIKO60-U13 Rev A
Date: 1st August 2017
Page: 8 of 37

2. DOCUMENT HISTORY

Document History		
Revision	Date	Comments
Draft	18 th June 2017	
Rev A	1 st August 2017	Initial release

This test report may be reproduced in full only. The document may only be updated by MiCOM Labs personnel and any changes noted in the Document History section of the report.

3. TEST RESULT CERTIFICATE

Applicant:	Mikrotik Pernavas 46 Riga, LV 1009 Latvia	Tested	MiCOM Labs, Inc. By: 575 Boulder Court Pleasanton, California 94566 USA
EUT	802.11 ac WLAN Access point	Tel:	+1 925 462 0304
Model:	RBSXTsqG-5acD	Fax:	+1 925 462 0306
S/N:	7C3F04B03EF9/720		
Test Dates:	24st May - 6th June 2017	Website:	www.micomlabs.com

STANDARD(S)	TEST RESULTS
FCC CFR 47 Part 15B & IC ICES-003	EQUIPMENT COMPLIES

MiCOM Labs, Inc. tested the equipment mentioned in accordance with the requirements set forth in the above standards. Test results indicate that the equipment tested is capable of demonstrating compliance with the requirements as documented within this report.

Notes:

- This document reports conditions under which testing was conducted and the results of testing performed.
- Details of the test methods used have been recorded and are kept on file by the laboratory.
- Test results apply only to the item(s) tested.

Approved & Released for MiCOM Labs, Inc. by:



TESTING CERT #2381.01



Graeme Grieve
Quality Manager MiCOM Labs, Inc.

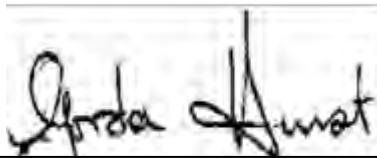

Gordon Hurst
President & CEO MiCOM Labs, Inc.

This test report may be reproduced in full only. The document may only be updated by MiCOM Labs personnel and any changes noted in the Document History section of the report.

4. REFERENCES AND MEASUREMENT UNCERTAINTY

4.1. Normative References

Ref.	Publication	Year	Title
(i)	FCC CFR 47 Part 15, Subpart B	2016	Title 47 CFR Part 15, Sub Part B; Unintentional Radiators
(ii)	ICES-003	Issue 6 January 2016	Information Technology Equipment (ITE) - Limits and methods of measurement
(iii)	ANSI C63.4	2014	American National Standards for Methods of Measurement of Radio-Noise Emissions from Low-Voltage Electrical and Electronic Equipment in the Range of 9 kHz to 40 GHz
(iv)	IEC 55016-2-3	2006	CISPR 16-2-3: "Specification for radio disturbance and immunity measuring apparatus and methods - Part 2-3: Methods of measurements of disturbances and immunity - Radiated disturbance measurements".
(v)	M 3003	Edition 2 Dec. 2007	Expression of Uncertainty and Confidence in Measurements
(vi)	LAB34	Edition 1 August 2002	The expression of uncertainty in EMC Testing
(vii)	ETSI TR 100 028	2001-12	Parts 1 and 2 Electromagnetic compatibility and Radio Spectrum Matters (ERM); Uncertainties in the measurement of mobile radio equipment characteristics
(viii)	A2LA	June 2015	R105 - Requirement's When Making Reference to A2LA Accreditation Status

This test report may be reproduced in full only. The document may only be updated by MiCOM Labs personnel and any changes noted in the Document History section of the report.

4.2. Test and Uncertainty Procedures

Conducted and radiated emission measurements were conducted in accordance with American National Standards Institute ANSI C63.4, listed in the Normative References section of this report.

Measurement uncertainty figures are calculated in accordance with ETSI TR 100 028 Parts 1 and 2.

Measurement uncertainties stated are based on a standard uncertainty multiplied by a coverage factor $k = 2$, providing a level of confidence of approximately 95 % in accordance with UKAS document M 3003 listed in the Normative References section of this report.



5. TEST SUMMARY

List of Measurements

The following table represents the list of measurements required under CISPR 24 standard.

TABLE OF REQUIRED TESTS – Emissions

Test Standard	Description	Limits	Compliance
FCC Part 15B & ICES-003	Radiated Emissions	Class B	Complies
FCC Part 15B & ICES-003	Conducted Emissions - ac power I/O port	Class B	Complies

This test report may be reproduced in full only. The document may only be updated by MiCOM Labs personnel and any changes noted in the Document History section of the report.



Title: MikroTik RBSXTsqG-5acD
To: FCC CFR 47 Part 15B & IC ICES-003
Serial #: MIKO60-U13 Rev A
Date: 1st August 2017
Page: 13 of 37

6. PRODUCT DETAILS AND TEST CONFIGURATIONS

6.1. Test Program Scope

The scope of the test program was to test the MikroTik RBSXTsqG-5acD for compliance against the appropriate emission standards listed within this report in order to satisfy the following standards.

- FCC CFR 47 Part 15, Subpart B - Title 47 CFR Part 15, SubPart B; Unintentional Radiators
- ICES-003 Issue 6 - Information Technology Equipment (ITE) - Limits and methods of measurement

This test report may be reproduced in full only. The document may only be updated by MiCOM Labs personnel and any changes noted in the Document History section of the report.

MikroTik RBSXTsqG-5acD
Front

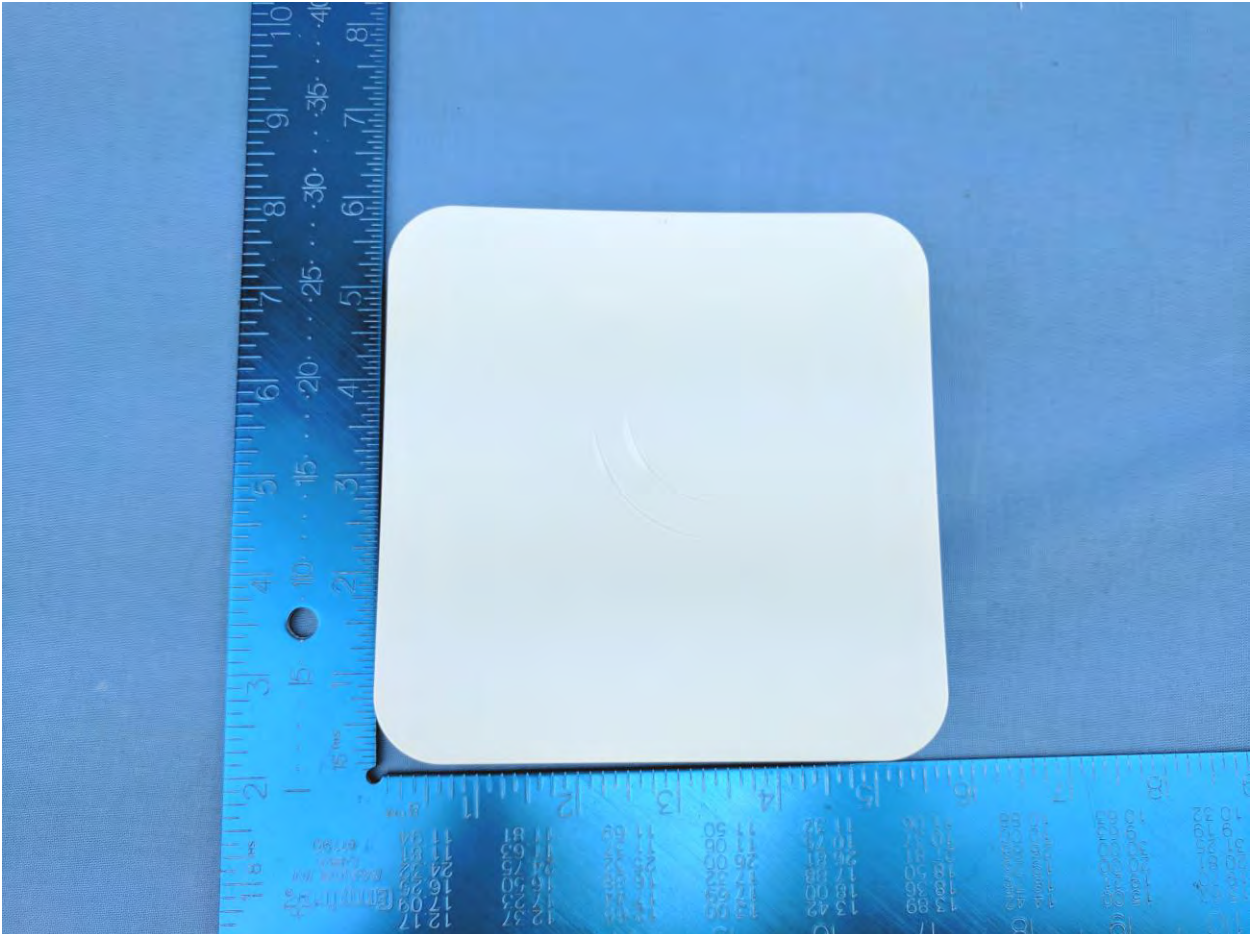

This test report may be reproduced in full only. The document may only be updated by MiCOM Labs personnel and any changes noted in the Document History section of the report.

MikroTik RBSXTsqG-5acD
Back



This test report may be reproduced in full only. The document may only be updated by MiCOM Labs personnel and any changes noted in the Document History section of the report.



Title: MikroTik RBSXTsqG-5acD
To: FCC CFR 47 Part 15B & IC ICES-003
Serial #: MIKO60-U13 Rev A
Date: 1st August 2017
Page: 16 of 37

6.2. EUT Details

Detail	Description
Purpose:	Test of the MikroTik RBSXTsqG-5acD for compliance to; FCC specification FCC Part 15B; ICES-003 Issue 6.
Applicant:	Mikrotik Pernavas 46, Riga, LV 1009 Latvia
Manufacturer:	Same as Applicant
Test Laboratory:	MiCOM Labs, Inc. 575 Boulder Court, Pleasanton, California 94566, USA
Test report reference number:	MIKO60-U13 Rev A
Date EUT received:	23 rd May 2017
Dates of test (from - to):	24 st May - 6 th June 2017
No of Units Tested:	One
Type of Equipment:	802.11a/b/g/n/ac
Product Name:	MikroTik RBSXTsqG-5acD 802.11a/b/g/n Wireless Access Point
Model No.:	RBSXTsqG-5acD
Serial No.:	7C3F04B03EF9/720
Equipment Secondary Function(s):	None
Type of Technology:	802.11a/b/g/n
Installation type:	Fixed
Construction/Location for Use:	Outdoor
Software/Firmware Release:	ROUTEROS v6.38.5
Hardware Release:	r2
Transmit/Receive Operation:	Transceiver - Full Duplex
Rated Input Voltage and Current:	100 – 240 V _{AC} 0.4A MAX, 50-60 Hz, PoE: 24Vdc, 0.38mA
Operating Frequency:	Rated: 50/60 Hz
Temperature:	-40°C to +70°C
Equipment Dimensions:	129 x 129 x 34mm
Weight:	174g
Primary Function:	Transmission of voice and data

This test report may be reproduced in full only. The document may only be updated by MiCOM Labs personnel and any changes noted in the Document History section of the report.



6.3. External A.C/D.C. Power Adaptor

Power adaptor/s were support items to the RBSXTsqG-5acD during testing. The AC/DC adapter can be used for PoE options.

AC/DC Adaptor
Manufacturer Unknown Model: AC Power Adapter Part Number: A00122400380FE0041 I: 100 – 240 V _{AC} 0.4A MAX, 50-60 Hz O: +24 V _{DC} 0.38 A

6.4. Antenna Details

No antennas were tested as part of this test program.

6.5. Cabling and I/O Ports

The following is a description of the cable and input, output ports available on the EUT;
Number and type of I/O ports;

Port Type	Port Description	Qty	Screened (Yes/ No)	Length
Ethernet	Ethernet Port	1	Yes	> 3m

6.6. Equipment Details

The following is a description of supporting equipment used during the test program.

Type (EUT/ Support)	Equipment Description (Including Brand Name)	Mfr.	Model No.	Serial No.
EUT	802.11 ac WLAN Access point	Mikrotik	RBSXTsqG-5acD	7C3F04B03EF9/720
Support	AC/DC Adaptor	-	AC Power Adapter	A00122400380FE0041
Support	PoE injector 9-48Vdc	Mikrotik	-	-
Support	Laptop PC	HP	Compact 8510p	--
Support	Laptop PC	IBM	Thinkpad	None

This test report may be reproduced in full only. The document may only be updated by MiCOM Labs personnel and any changes noted in the Document History section of the report.



Title: MikroTik RBSXTsqG-5acD
To: FCC CFR 47 Part 15B & IC ICES-003
Serial #: MIKO60-U13 Rev A
Date: 1st August 2017
Page: 18 of 37

6.7. Equipment Modifications

No modifications were required to bring the equipment into compliance:

6.8. Deviations from the Test Standard

No deviations from the test standard were required in order to complete the test program:

This test report may be reproduced in full only. The document may only be updated by MiCOM Labs personnel and any changes noted in the Document History section of the report.



Title: MikroTik RBSXTsqG-5acD
To: FCC CFR 47 Part 15B & IC ICES-003
Serial #: MIKO60-U13 Rev A
Date: 1st August 2017
Page: 19 of 37

6.9. EUT Configurations

6.9.1. EUT Configuration - Radiated Emissions:

The RBSXTsqG-5acD setup consist of 1 configuration AC/DC connected with a PoE injector.

Laptop (1) used to initiate settings of EUT into normal operation and in continuous transmissions TX mode.

Laptop (1) used to exercise/monitor Ethernet network connected to EUT via Ethernet port.

1m of unshielded CAT5 cables was left exposed running from the EUT. The remaining cable length was routed under the ground plane into an attached shielded "control" room outside the chamber. EUT USB Ports were left un-terminated during emissions testing (Maintenance Only).

This test report may be reproduced in full only. The document may only be updated by MiCOM Labs personnel and any changes noted in the Document History section of the report.

Diagram of EUT Configuration for Emissions Measurements

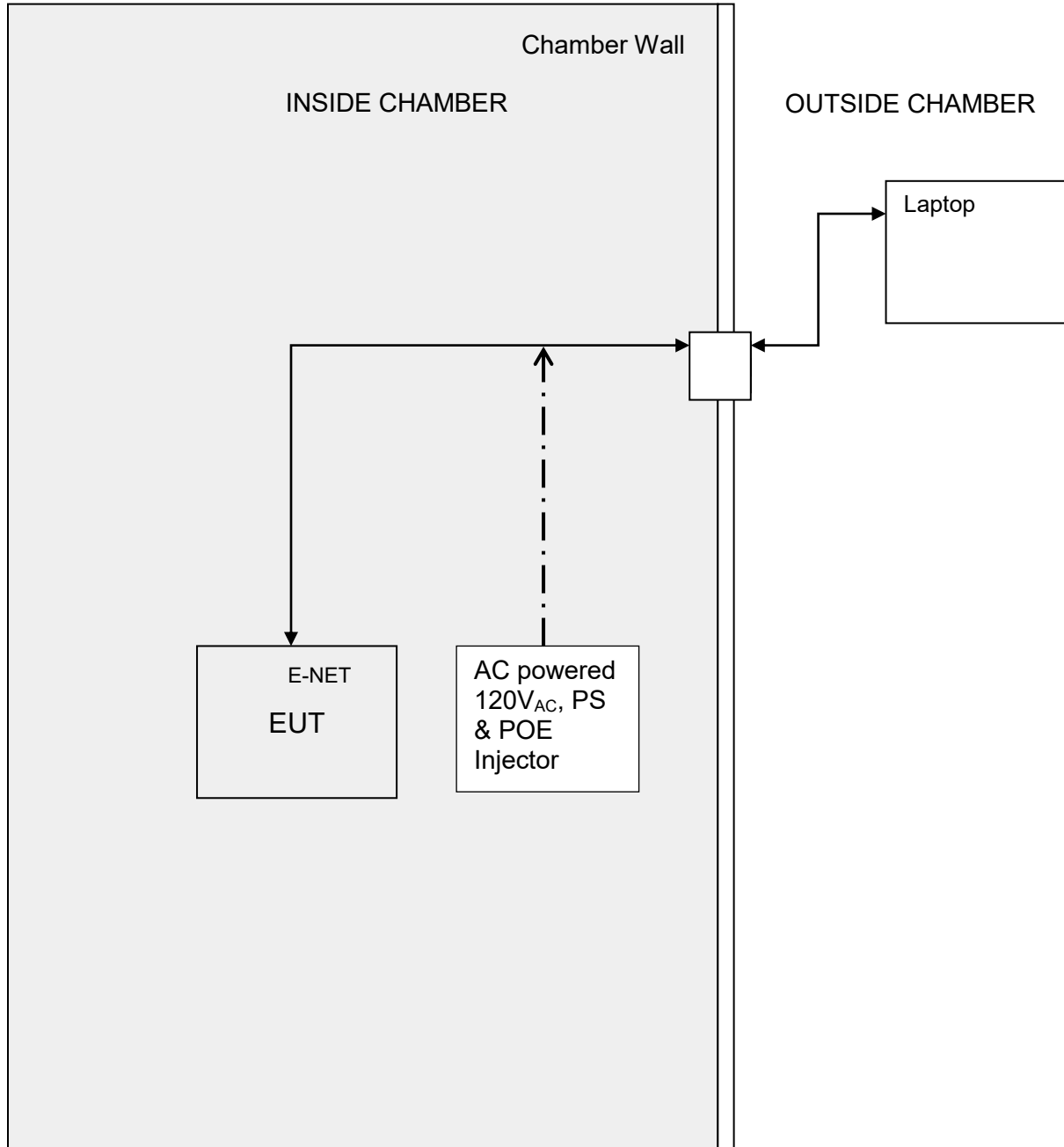

This test report may be reproduced in full only. The document may only be updated by MiCOM Labs personnel and any changes noted in the Document History section of the report.



Title: MikroTik RBSXTsqG-5acD
To: FCC CFR 47 Part 15B & IC ICES-003
Serial #: MIKO60-U13 Rev A
Date: 1st August 2017
Page: 21 of 37

7. TEST RESULTS

7.1. EMC EMISSIONS TEST RESULTS

7.1.1. Radiated Emissions

FCC, Part 15 Subpart B §15.109
Industry Canada ICES-003 Section 6.2

Test Procedure

Testing 30 – 1,000 MHz was performed in a anechoic chamber using a CISPR compliant receiver. Preliminary radiated emissions were measured on every azimuth and with the receiving antenna in both horizontal and vertical polarizations. To further maximize emissions the receive antenna was varied between 1 and 4 meters. The emissions are recorded with receiver in peak hold mode.

Emissions nearest the limits were chosen for maximization and formal measurement using a CISPR Compliant receiver. Emissions from 30 MHz – 1000 MHz are measured utilizing a CISPR compliant quasi-peak detector with a tuned receiver, using a bandwidth of 120 kHz. Emissions above 1000 MHz are measured utilizing a CISPR compliant average detector with a tuned receiver, using a bandwidth of 1 MHz. Only the highest emissions relative to the limit are listed.

This test report may be reproduced in full only. The document may only be updated by MiCOM Labs personnel and any changes noted in the Document History section of the report.



Field Strength Calculation

The field strength is calculated by adding the Antenna Factor and Cable Loss, and subtracting Amplifier Gain from the measured reading. All factors are included in the reported data.

$$\mathbf{FS = R + AF + CORR - FO}$$

FS = Field Strength
R = Measured Spectrum analyzer Input Amplitude
AF = Antenna Factor
FO = Distance Falloff Factor

$$\mathbf{CORR = Correction Factor = CL - AG + NFL}$$

CL = Cable Loss
AG = Amplifier Gain
NFL = Notch Filter Loss or Waveguide Loss

Field Strength Calculation Example:

Given receiver input reading of 51.5 dB μ V; Antenna Factor of 8.5 dB; Cable Loss of 1.3 dB; Falloff Factor of 0 dB, an Amplifier Gain of 26 dB and Notch Filter Loss of 1 dB. The Field Strength of the measured emission is:

$$FS = 51.5 + 8.5 + 1.3 - 26.0 + 1 = 36.3 \text{ dB}\mu\text{V/m}$$

Conversion between dB μ V/m (or dB μ V) and μ V/m (or μ V) are done as:

$$\text{Level (dB}\mu\text{V/m)} = 20 * \text{Log (level (\mu\text{V/m}))}$$

$$40 \text{ dB}\mu\text{V/m} = 100 \mu\text{V/m}$$

$$48 \text{ dB}\mu\text{V/m} = 250 \mu\text{V/m}$$

Limits

The ancillary equipment shall meet the class B limits given in CISPR 22, and the limits above 1 GHz shown below.

FCC Spurious Emissions Limits

Limits below 1 GHz:

Class A limits

Frequency(MHz)	Quasi-peak Limit (dB μ V/m)	Measurement Distance (meters)	Quasi-peak Limit (dB μ V/m)	Measurement Distance (meters)
30 to 88	40	10	49.5	3
88-216	43.5	10	54	3
216-960	46.4	10	56.5	3
960-1000	49.5	10	60	3

Class B limits

Frequency(MHz)	Quasi-peak Limit (dB μ V/m)	Measurement Distance (meters)	Quasi-peak Limit (dB μ V/m)	Measurement Distance (meters)
30 to 88	29.5	10	40	3
88-216	33	10	43.5	3
216-960	35.6	10	46	3
960-1000	43.5	10	54	3

Limits above 1GHz:

Frequency(MHz)	Average Limit (dB μ V/m)	Peak Limit (dB μ V/m)	Measurement Distance (meters)	Class (A/B)
1 000 to 6000	54	74	3	Class B

Frequency(MHz)	Average Limit (dB μ V/m)	Peak Limit (dB μ V/m)	Measurement Distance (meters)	Class (A/B)
1 000 to 6000	60	80	3	Class A

Traceability

Laboratory Measurement Uncertainty	
Measurement uncertainty	+5.6/ -4.5 dB

Method
Measurements were made per work instruction Work instruction WI-07 Radiated Emissions Test

This test report may be reproduced in full only. The document may only be updated by MiCOM Labs personnel and any changes noted in the Document History section of the report.



Test Equipment Utilized

Asset#	Description	Manufacturer	Model#	Serial#	Calibration Due Date
158	Barometer/Thermometer	Control Company	4196	E2846	30 Nov 2017
170	Video System Controller for Semi Anechoic Chamber	Panasonic	WV-CU101	04R08507	Not Required
287	Rohde & Schwarz 40 GHz Receiver	Rhode & Schwarz	ESIB40	100201	02 May 2018
338	Sunol 30 to 3000 MHz Antenna	Sunol	JB3	A052907	15 Aug 2017
373	26III RMS Multimeter	Fluke	Fluke 26 series III	76080720	26 Oct 2017
377	Band Rejection Filter 5150 to 5880MHz	Microtronics	BRM50716	034	16 Aug 2017
396	2.4 GHz Notch Filter	Microtronics	BRM50701	001	16 Aug 2017
397	Amp 10 - 2500MHz	MiCOM Labs	Amp 10 - 2500 MHz	NA	09 Jul 2017
399	ETS 1-18 GHz Horn Antenna	ETS	3117	00154575	10 Oct 2017
406	Amplifier for Radiated Emissions	MiCOM Labs	40dB 1 to 18GHz Amp	0406	09 Jul 2017
410	Desktop Computer	Dell	Inspiron 620	WS38	Not Required
411	Mast/Turntable Controller	Sunol Sciences	SC98V	060199-1D	Not Required
412	USB to GPIB Interface	National Instruments	GPIB-USB HS	11B8DC2	Not Required
413	Mast Controller	Sunol Science	TWR95-4	030801-3	Not Required
415	Turntable Controller	Sunol Sciences	Turntable Controller	None	Not Required
416	Gigabit ethernet filter	ETS-Lingren	Gigafoil 260366	None	Not Required
447	Rad Emissions Test Software	MiCOM	Rad Emissions Test Software Version 1.0.109	447	Not Required
462	Schwarzbeck cable from Antenna to Amplifier.	Schwarzbeck	AK 9513	462	16 Aug 2017
463	Schwarzbeck cable from Amplifier to Bulkhead.	Schwarzbeck	AK 9513	463	16 Aug 2017
464	Schwarzbeck cable from Bulkhead to Receiver	Schwarzbeck	AK 9513	464	16 Aug 2017

This test report may be reproduced in full only. The document may only be updated by MiCOM Labs personnel and any changes noted in the Document History section of the report.



Title: MikroTik RBSXTsqG-5acD
To: FCC CFR 47 Part 15B & IC ICES-003
Serial #: MIKO60-U13 Rev A
Date: 1st August 2017
Page: 25 of 37

480	Cable - Bulkhead to Amp	SRC Haverhill	157-157-3050360	480	16 Aug 2017
481	Cable - Bulkhead to Receiver	SRC Haverhill	151-151-3050787	481	16 Aug 2017
482	Cable - Amp to Antenna	SRC Haverhill	157-157-3051574	482	16 Aug 2017
502	Test Software for Radiated Emissions	EMISoft	Vasona	Version 5 Build 59	Not Required
CC05	Confidence Check	MiCOM	CC05	None	26 Jun 2017

This test report may be reproduced in full only. The document may only be updated by MiCOM Labs personnel and any changes noted in the Document History section of the report.

Test Setup for Radiated Emissions for above and below 1 GHz

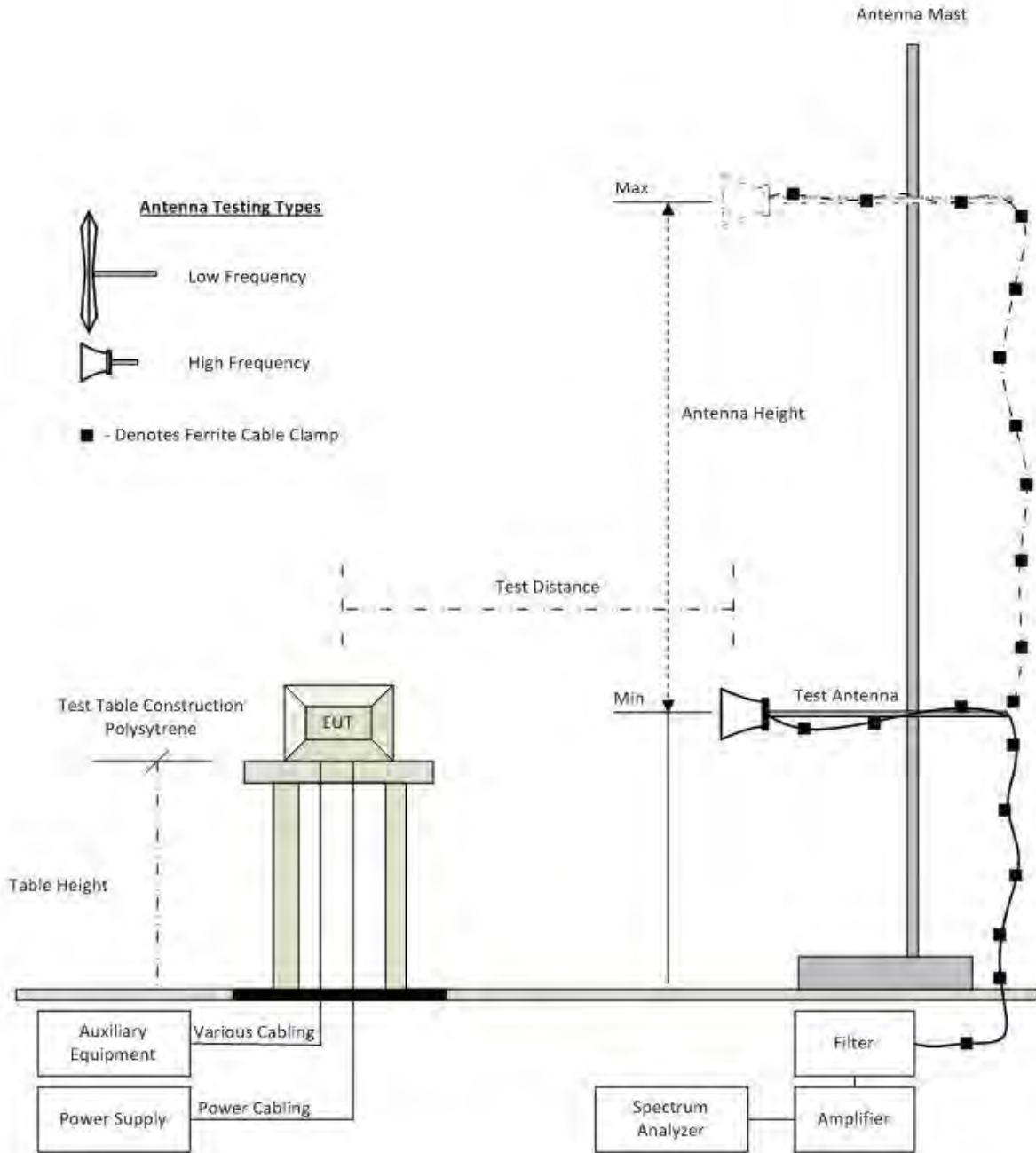

Radiated Emission Test Setup

This test report may be reproduced in full only. The document may only be updated by MiCOM Labs personnel and any changes noted in the Document History section of the report.

7.1.1.1. Measurement Results: 30-1000MHz - Class B

Model:	RBSXTsqG-5acD	Configuration tested:	AC/DC Powered
Input power:	120V/60Hz	Standard:	FCC 15B



Variant: Digital Emissions, Test Freq: 5180.00 MHz, Power Setting: 18, Duty Cycle (%): 100

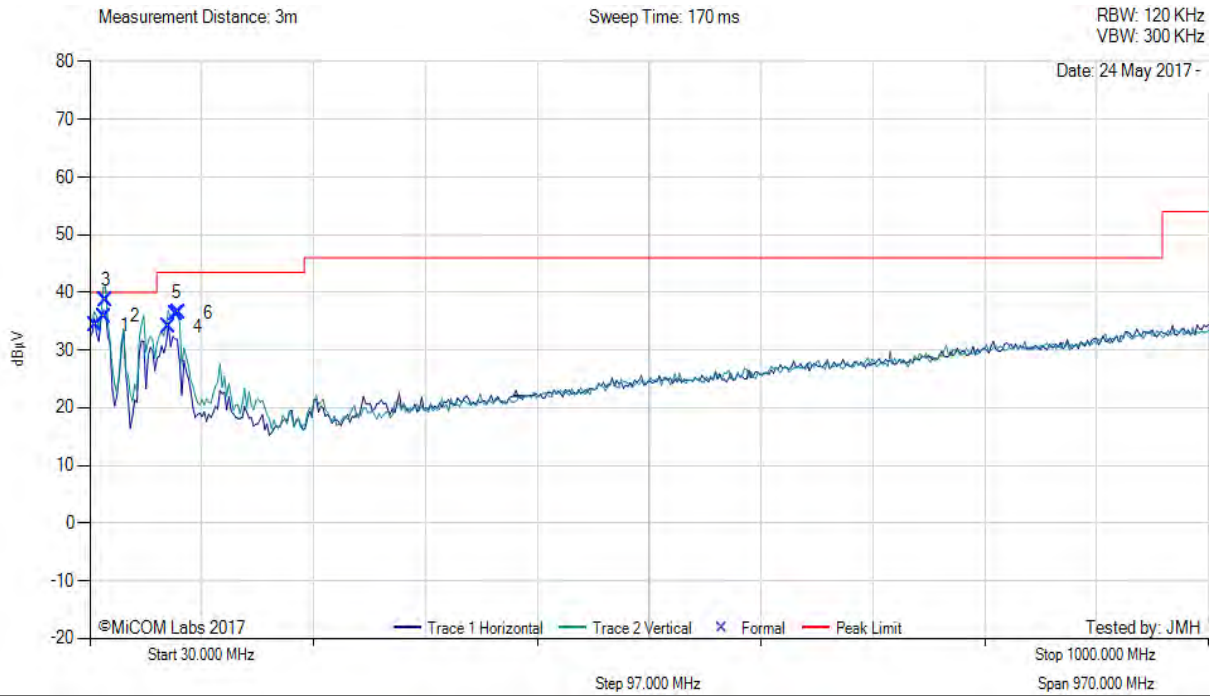

30.00 - 1000.00 MHz												
Num	Frequency MHz	Raw dBµV	Cable Loss dB	AF dB	Level dBµV/m	Measurement Type	Pol	Hgt cm	Azt Deg	Limit dBµV/m	Margin dB	Pass /Fail
1	34.62	44.49	3.46	-13.58	34.37	MaxQP	Vertical	101	157	40.0	-5.6	Pass
2	42.91	51.88	3.52	-19.56	35.84	MaxQP	Vertical	119	35	40.0	-4.2	Pass
3	43.80	55.43	3.53	-20.36	38.60	MaxQP	Vertical	98	76	40.0	-1.4	Pass
4	98.44	51.69	3.87	-21.54	34.02	MaxQP	Vertical	105	212	43.5	-9.5	Pass
5	104.73	52.32	3.91	-19.93	36.30	MaxQP	Vertical	101	242	43.5	-7.2	Pass
6	106.70	51.97	3.92	-19.43	36.46	MaxQP	Vertical	100	110	43.5	-7.0	Pass

Test Notes: EUT powered by poe injector. Connected to laptop outside chamber. Transmitting on 5180 MHz for loading purposes.

This test report may be reproduced in full only. The document may only be updated by MiCOM Labs personnel and any changes noted in the Document History section of the report.



Title: MikroTik RBSXTsqG-5acD
To: FCC CFR 47 Part 15B & IC ICES-003
Serial #: MIKO60-U13 Rev A
Date: 1st August 2017
Page: 28 of 37

7.1.2. AC Mains Power Input/Output Ports

Scope

This test assesses the ability of the EUT to limit its internal noise from being present on the AC mains power input/output ports.

Test Method

The test method shall be in accordance with CISPR 22 and the Artificial Mains Networks (AMNs) shall be connected to the AC mains power source.

The measurement frequency range extends from 150 kHz to 30 MHz. When the EUT is a transmitter operating at frequencies below 30 MHz, then the exclusion band for transmitters applies for measurements in the transmit mode of operation.

Test Procedure

The conducted emissions are measured in a shielded room with a spectrum analyzer in peak hold in the first instance. Emissions closest to the limit are measured in the quasi-peak mode (QP) with the tuned receiver using a bandwidth of 9 kHz. The emissions are maximized further by cable manipulation. The highest emissions relative to the limit are listed.

This test report may be reproduced in full only. The document may only be updated by MiCOM Labs personnel and any changes noted in the Document History section of the report.

Limits

The equipment shall meet the class B limits given in CISPR 22. Alternatively, for equipment intended to be used in telecommunication centres only, the class A limits given in CISPR 22 may be used.

Class B Emissions

Frequency of Emission (MHz)	Conducted Limit (dB μ V)	
	Quasi-peak	Average
0.15-0.5	66 to 56*	56 to 46*
0.5-5	56	46
5-30	60	50

* Decreases with the logarithm of the frequency

Class A Emissions

Frequency of Emission (MHz)	Conducted Limit (dB μ V)	
	Quasi-peak	Average
0.15-0.5	79	66
0.5-30	73	60

Traceability

All conducted emission measurements are traceable to national standards. The uncertainty of measurement at a confidence level of not less than 95 %, with a coverage factor of k=2, in the range 9 kHz – 30 MHz (Average & Quasi-peak) is ± 2.64 dB.

Laboratory Measurement Uncertainty	
Measurement uncertainty	± 2.64 dB

Method
Measurements were made per work instruction WI-EMC-01 'Measurement of Conducted Emissions'



Title: MikroTik RBSXTsqG-5acD
To: FCC CFR 47 Part 15B & IC ICES-003
Serial #: MIKO60-U13 Rev A
Date: 1st August 2017
Page: 30 of 37

Test Equipment Utilized

Asset#	Description	Manufacturer	Model#	Serial#	Calibration Due Date
158	Barometer/Thermometer	Control Company	4196	E2846	30 Nov 2017
184	Pulse Limiter	Rhode & Schwarz	ESH3Z2	357.8810.52	6 Jul 2017
190	LISN (two-line V-network)	Rhode & Schwarz	ESH3Z5	836679/006	29 Oct 2017
193	Receiver 20 Hz to 7 GHz	Rhode & Schwarz	ESI 7	838496/007	10 Oct 2017
307	BNC-CABLE	Megaphase	1689 1GVT4	15F50B002	6 Oct 2017
316	Dell desktop computer workstation with Vasona	Dell	Desktop	WS04	Not Required
351	Data Impedance Stabilization Network	Teseq	ISN T800	24809	30 Nov 2017
372	AC Variable PS	California Instruments	1251P	L06951	Cal when used
388	LISN (3 Phase) 9kHz - 30MHz	Rohde & Schwarz	ESH2-Z5	892107/022	30 Oct 2017
496	MiTest Conducted Emissions Test Software	MiCOM	Conducted Emissions Test Software Version 1.0.87	496	Not Required
ADAPT SMA#1	SMA Cable	Megaphase	SMA Cable #1	None	6 Oct 2017
CCEMC01	Confidence Check	MiCOM	CCEMC01	None	6 Jul 2017

This test report may be reproduced in full only. The document may only be updated by MiCOM Labs personnel and any changes noted in the Document History section of the report.

Test Setup – Power Input / Output Port

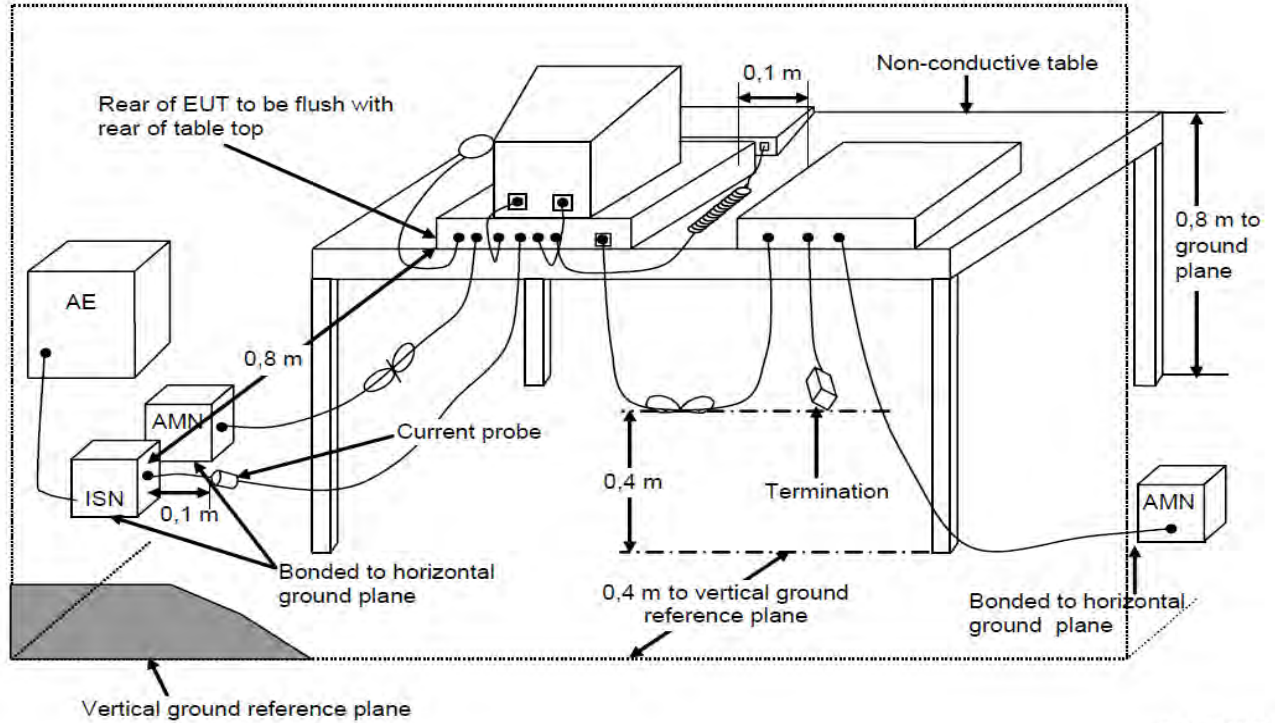

IEC 1344/08

This test report may be reproduced in full only. The document may only be updated by MiCOM Labs personnel and any changes noted in the Document History section of the report.



Measurement Results

Model:	RBSXTsqG-5acD	Configuration tested:	AC/DC POWERED
Input power:	120V _{AC} /60Hz	Standard:	FCC 15B



Variant: , Test Freq: 0.00 MHz

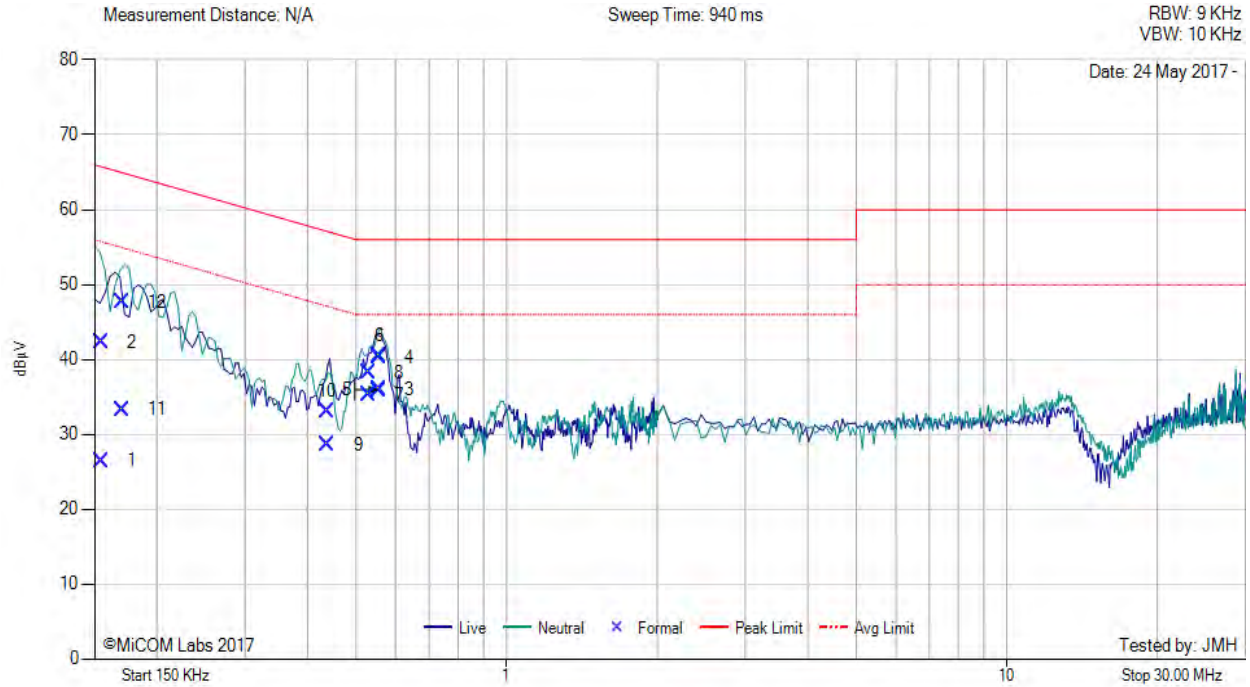

Num	Frequency MHz	Raw dBµV	Cable Loss dB	Factor dB	Total Correction dBµV	Corrected Value dBµV	Measurement Type	Line	Limit dBµV/m	Margin dB	Pass /Fail
1	0.155	16.53	0.05	9.92	9.97	26.50	Max Avg	Neutral	55.9	-29.4	Pass
2	0.155	32.32	0.05	9.92	9.97	42.29	Max Qp	Neutral	65.9	-23.6	Pass
3	0.555	25.89	0.10	9.92	10.02	35.91	Max Avg	Neutral	46.0	-10.1	Pass
4	0.555	30.22	0.10	9.92	10.02	40.24	Max Qp	Neutral	56.0	-15.8	Pass
5	0.556	25.96	0.10	9.92	10.02	35.98	Max Avg	Live	46.0	-10.0	Pass
6	0.556	30.46	0.10	9.92	10.02	40.48	Max Qp	Live	56.0	-15.5	Pass
7	0.530	25.26	0.09	9.92	10.01	35.27	Max Avg	Neutral	46.0	-10.7	Pass
8	0.530	28.24	0.09	9.92	10.01	38.25	Max Qp	Neutral	56.0	-17.8	Pass
9	0.439	18.62	0.05	9.93	9.98	28.60	Max Avg	Live	47.7	-19.1	Pass
10	0.439	23.10	0.05	9.93	9.98	33.08	Max Qp	Live	57.7	-24.7	Pass
11	0.170	23.37	0.05	9.92	9.97	33.34	Max Avg	Neutral	55.4	-22.1	Pass
12	0.170	37.69	0.05	9.92	9.97	47.66	Max Qp	Neutral	65.4	-17.8	Pass

Test Notes: Model: RouterBOARD SXTsq G-5acD. ACDC+PoE configuration. 120V, 60Hz. AC mains.

This test report may be reproduced in full only. The document may only be updated by MiCOM Labs personnel and any changes noted in the Document History section of the report.

8. PHOTOGRAPHS

8.1. Radiated Emissions Front

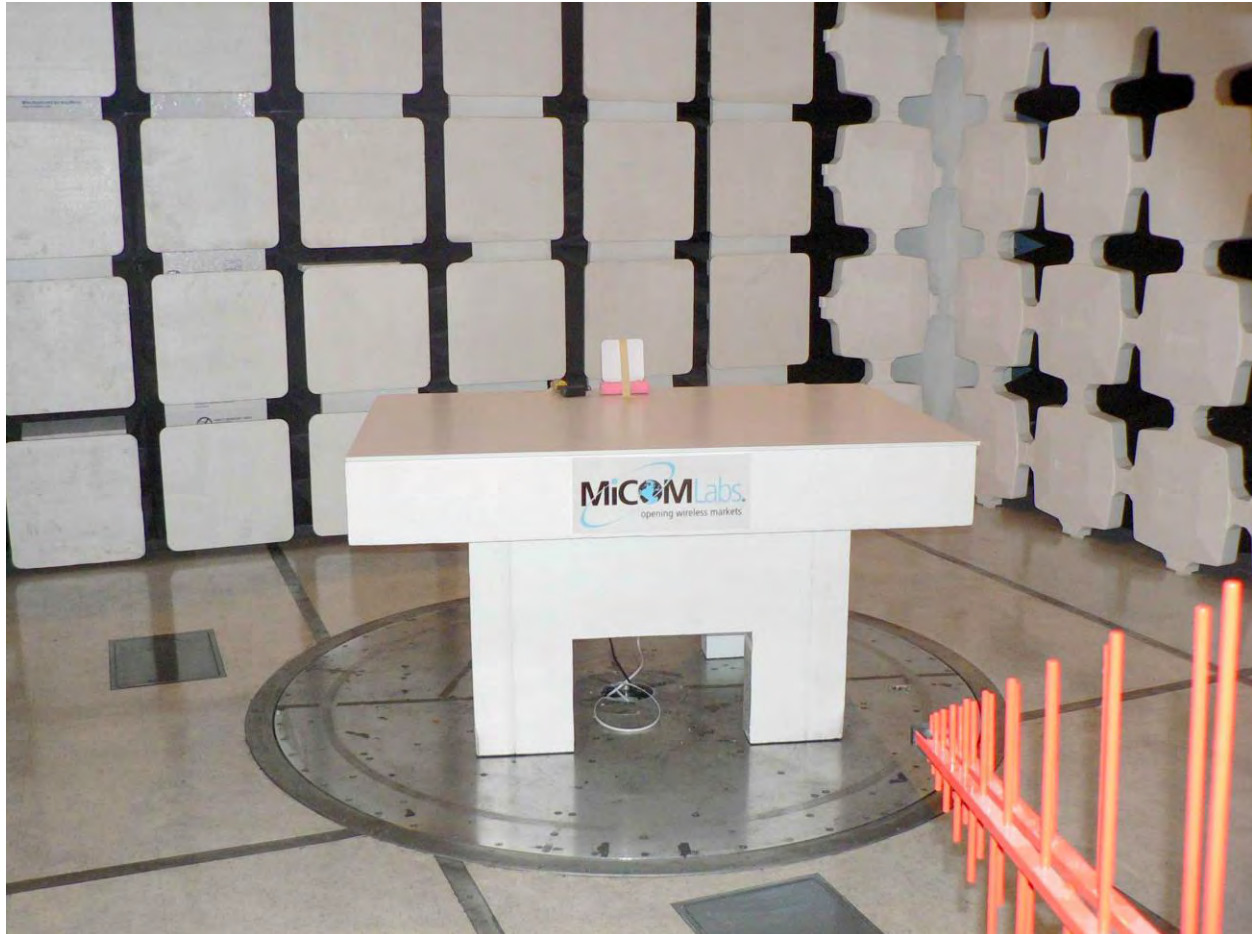

Note: Laptop located outside chamber.

This test report may be reproduced in full only. The document may only be updated by MiCOM Labs personnel and any changes noted in the Document History section of the report.

8.2. Radiated Emissions Back

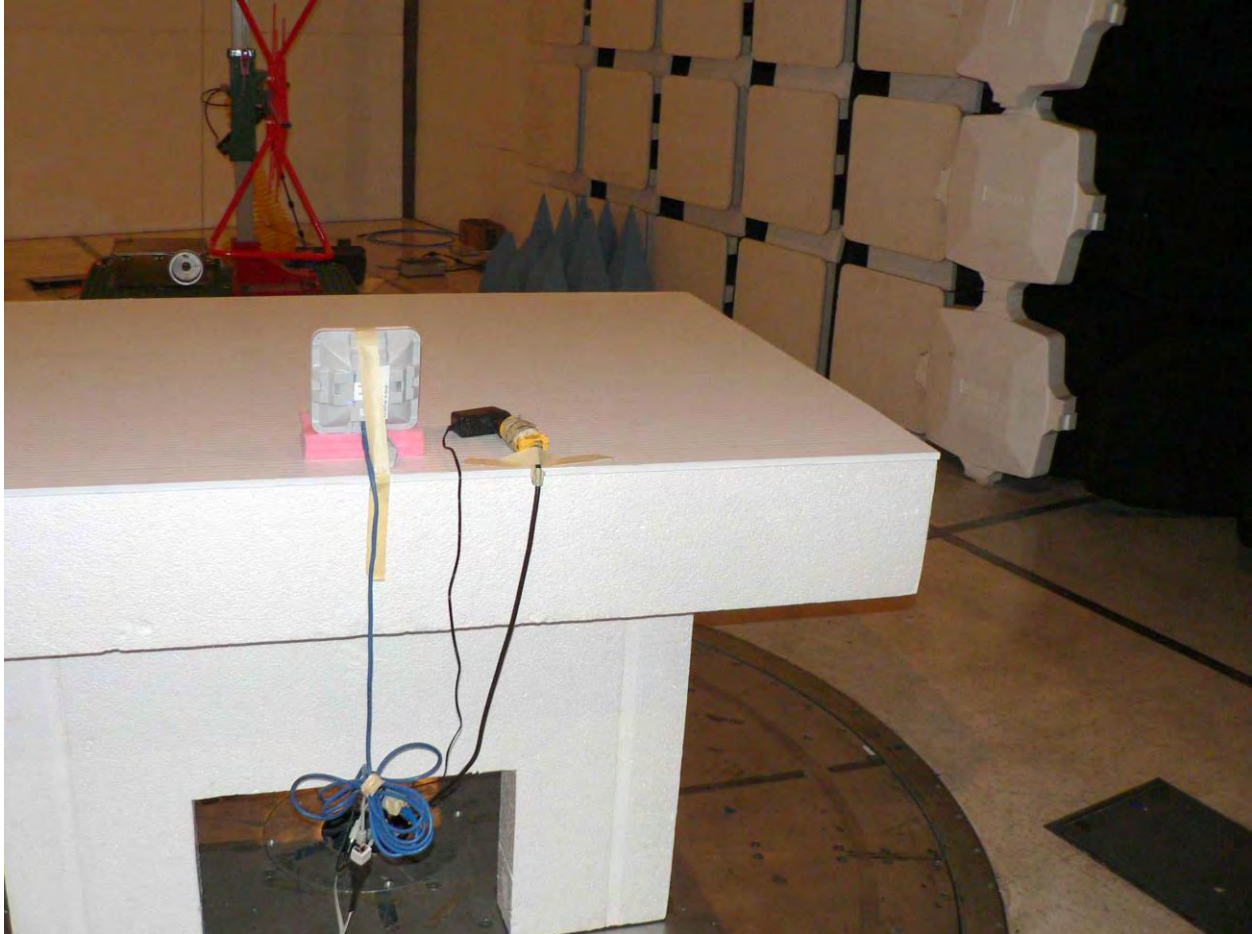

Note: Laptop located outside chamber.

8.1. AC Wireline Emissions



AC/DC powered

This test report may be reproduced in full only. The document may only be updated by MiCOM Labs personnel and any changes noted in the Document History section of the report.

AC/DC powered Side View

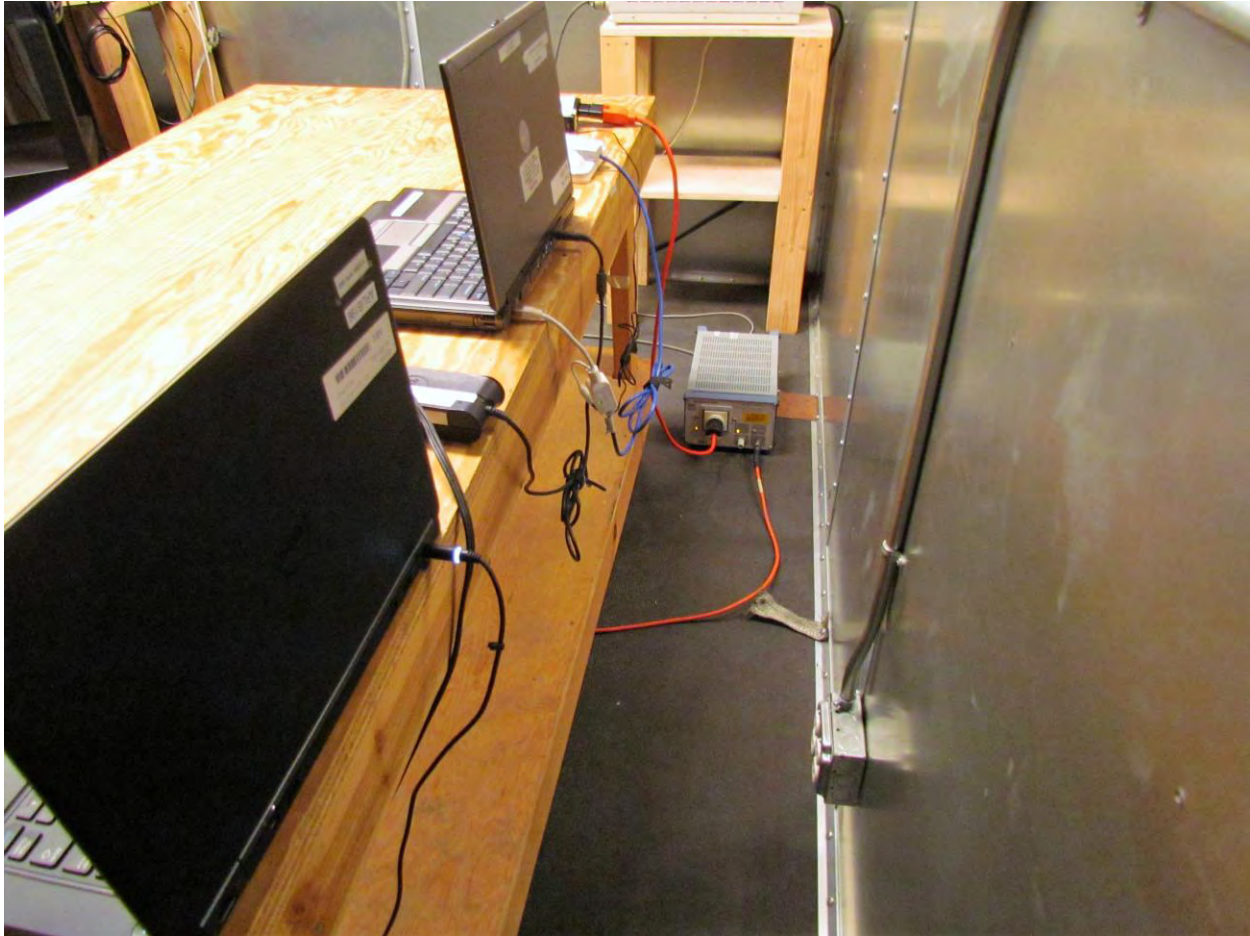

This test report may be reproduced in full only. The document may only be updated by MiCOM Labs personnel and any changes noted in the Document History section of the report.



575 Boulder Court,
Pleasanton, California 94566, USA
Tel: 1.925.462.0304
Fax: 1.925.462.0306
www.micomlabs.com