



FCC TEST REPORT



Product Name	CDMA Fixed Wireless Terminal
Model Name	LSP-430G
Applicant	LG-Nortel Co., Ltd.
FCC ID	TUILSP430G

ESTECH CO., LTD

Rm. 1015 World Venture Center, 426-5 Gasan-dong, Geumcheon-gu,
Seoul, 153-803, Korea. Tel:82-2-867-3201, Fax:82-2-867-3204



FCC Test Report

Report Number	ESTR0903-005			
Applicant	Company Name	LG-Nortel Co., Ltd.		
	Address	533, Hogye-1dong, Dongan-gu, Anyang-shi, Kyongki-do, 431-749, Korea		
Product	Product Name	CDMA Fixed Wireless Terminal		
	Model No.	LSP-430G	Manufacturer	LG-Nortel Co., Ltd.
	Serial No.	NONE	Country of origin	KOREA
Other	Issued Date	2009-03-05	Tested Date	2009-02-24 ~ 2009-03-05
Test Result	Pass			
Standard	FCC PART 22 Subpart H			
Tested by	I.K. Hong/ Engineer		(Signature)	
Approved by	Eun young Son/ Engineering Manager		(Signature)	
ESTECH CO., LTD				
Rm. 1015 World Venture Center, 426-5 Gasan-dong, Geumcheon-gu, Seoul, 153-803, Korea. Tel:82-2-867-3201, Fax:82-2-867-3204				
<ul style="list-style-type: none"> o This is certified that the above mentioned products have been tested for the sample provided by client. o No part of this document may not be duplicated or reproduced by any means without the express written permission of Estech Co., Ltd. o This device is used three models adapter (adapter model: WPA-162T , WPA-170T , WPA-152) o This device is used two colors cover red and gray 				



Contents

1. General Information	Page 4
2. Laboratory Information	Page 5
3. Summary of Test Results	Page 5
4. RF Output Power	Page 6
5. Occupied Bandwidth	Page 10
6. Spurious and Harmonic Emission at Antenna Terminal	Page 12
7. Field Strength of Spurious Radiation	Page 17
8. Frequency stability	Page 21



1. General Information

1.1 EUT Description

FCC ID	TUILSP430G
Product Name	CDMA Fixed Wireless Terminal
Model Name	LSP-430G
Frequency	Tx :824.70 ~ 848.31MHz
	Rx :869.70 ~ 893.31MHz
Channel	CDMA (1013/363/777)
Modulation Type	CDMA
Power Rating	110VAC(85 ~ 145VAC)

2. Laboratory Information

2.1 Laboratory Name Estech Co., Ltd.

2.2 Location

Head Office Rm. 1015, World Venture Center II, 426-5 Gasan-dong
 Geumcheon-gu, Seoul, 153-803. Korea.

EMC Lab(Ichon) 58-1, Osan-Ri, GaNam-Myon, YeoJoo-Gun, KyungKi-Do, Korea

EMC Lab(Yanggi) 97-1, Hoiuk-Ri Majang-Myon, Icheon-city, KyungKi-Do, Korea

2.3 Quality System Accredited by KOLAS(ISO/IEC 17025)

2.4 Major Accredited Mark



3. Summary of Test Results

Test Item	Standard	Result
RF Output Power	Part 22	PASS
Occupied Bandwidth		PASS
Spurious and Harmonic Emission at Antenna Terminal		PASS
Field Strength of Spurious Radiation		PASS
Frequency stability		PASS

4. RF Output Power

4.1 Test Procedure according to ANSI/TIA/EIA 603 Clause 2.2.17

1. The EUT was placed on a wooden turn table 3 meters from the receive antenna. The receive antenna height and turn table rotation was adjusted for the highest reading on the receive spectrum analyzer. For CDMA signals, a peak detector is used, with RBW = VBW = 3MHz. For AMPS, GSM, and NADC TDMA signals, a peak detector is used, with RBW = VBW = 1MHz, A Horn antenna was substituted in place of the EUT. This Horn antenna was driven by a signal generator and the level of the signal generator was adjusted to obtain the same receive spectrum analyzer reading. This spurious level is recorded. For reading 1GHz, the above procedure is repeated using horn antennas and the difference between the gain of the horn and an isotropic or dipole antenna are taken into consideration.
2. The RF output port of the EUT was connected to the dual directional coupler and Wireless communications test set connected dual directional coupler. The RF Power is measured Power matter This test was performed three channels (Low, High, Middle)
3. Test setup for RF Conducted measurement

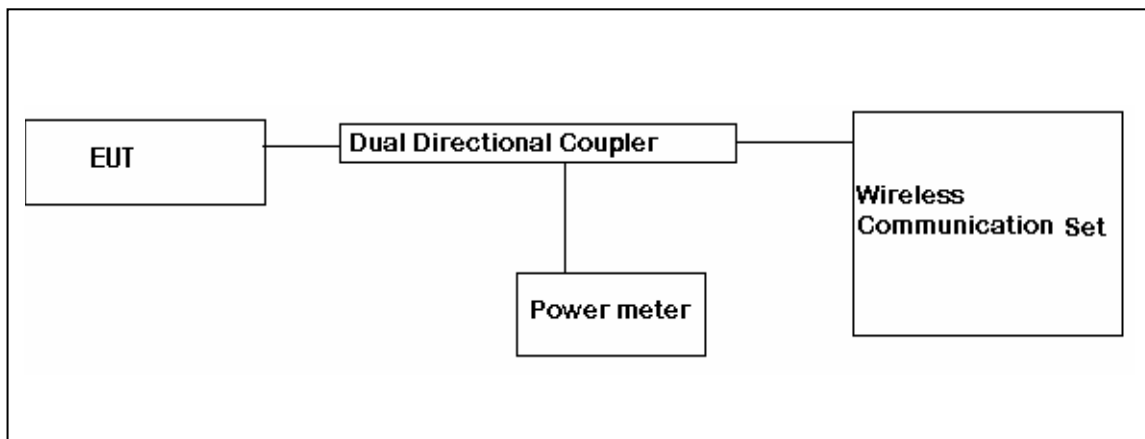

4.2 Test Equipments

The following test equipments are used during tests

Equipment	Manufacturer	Model	Cal. Due Date
Spectrim Analyzer	ADVANTEST	R3273	2009-06-01
Signal Generator	HP	83620B	2009-09-01
Power Meter	HP	EPM-442A	2009-10-13
Dual Directional Coupler	HP	778D	2010-02-28
Wireless Communications	Agilent	E5515C	2010-02-17
Pre Amplifier	HP	8449B	2009-12-15
Horn Antenna	SCHWARZBECK	BBHA 9120 D	2009-06-13
Horn Antenna	SCHWARZBECK	BBHA 9120 D	2009-06-13



4.3. Test Results

Ch No.	Freq (MHz)	Peak Power Meter(dBm)	Peak Power ERP(dBm) (ADAPTER:WPA-162T)
1013	824.70	24.86	26.90
363	835.89	24.71	26.19
777	848.31	24.00	26.01

Ch No.	Freq (MHz)	Peak Power ERP(dBm) (ADAPTER:WPA-170T)	Peak Power ERP(dBm) (ADAPTER:WPA-152)
1013	824.70	27.00	26.90
363	835.89	26.29	26.39
777	848.31	26.01	26.21

Remark : The Conducted RF Measurement will be listed on the Grant of this device
Since it has a removable antenna



(ADAPTER:WPA-162T)

FREQ (MHz)	Receiver Reading (dBuV)	Correction Factor (dB)		[SG Reading +AMP] (dBm)	ERP (dBm)	Limit (dBm)	POL (H/V)
		Antenna gain(dBi)	Cable Loss (dB)				
824.70	95.90	1	8.90	34.80	26.90	38.5	V
835.89	95.20	1.29	9.20	34.10	26.19	38.5	V
848.31	93.65	1.61	9.20	33.60	26.01	38.5	V

(ADAPTER:WPA-170T)

FREQ (MHz)	Receiver Reading (dBuV)	Correction Factor (dB)		[SG Reading +AMP] (dBm)	ERP (dBm)	Limit (dBm)	POL (H/V)
		Antenna gain(dBi)	Cable Loss (dB)				
824.70	96.00	1	8.90	34.90	27.00	38.5	V
835.89	95.20	1.29	9.20	34.20	26.29	38.5	V
848.31	93.65	1.61	9.20	33.60	26.01	38.5	V

(ADAPTER:WPA-152)

FREQ (MHz)	Receiver Reading (dBuV)	Correction Factor (dB)		[SG Reading +AMP] (dBm)	ERP (dBm)	Limit (dBm)	POL (H/V)
		Antenna gain(dBi)	Cable Loss (dB)				
824.70	95.90	1	8.90	34.80	26.90	38.5	V
835.89	95.40	1.29	9.20	34.30	26.39	38.5	V
848.31	95.60	1.61	9.20	33.80	26.21	38.5	V



CDMA-2000 RC Output Power Table(LSP-430G)

FREQ (MHz)	CDMA2000 RC	S02 Loopback	S055 Loopback	S032 (+SCH)	S032 (+F-SCH)
824.70	RC1	24.86	24.84	-	-
	RC3	24.78	24.76	-	-
835.89	RC1	24.64	24.70	-	-
	RC3	24.68	24.71	-	-
848.31	RC1	24.00	23.99	-	-
	RC3	23.96	23.93	-	-

5. Occupied Bandwidth

5.1 Test Procedure

The transmitter output is connected to the spectrum analyzer. The RBW is set to 1% of the Emission bandwidth. The VBW is set to 3 times the RBW. The sweep time is coupled.

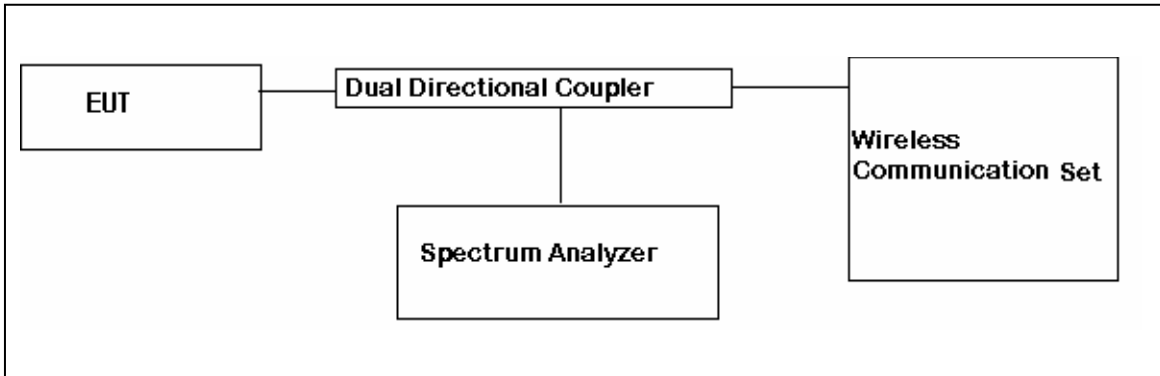

5.2 Test Equipments

The following test equipments are used during tests

Equipment	Manufacturer	Model	Cal. Due Date
Spectrum Analyzer	Agilent	E4407B	2010-02-26
Dual Directional Coupler	HP	778D	2010-02-28
Wireless Communications Test Set	Agilent	E5515C	2010-02-17

5.3 Test Results

Channel	Frequency(MHz)	26dB Bandwidth(MHz)
1013	824.70	1.402
363	835.89	1.419
777	848.31	1.432



5.4 Test Plot

26dB Channel Bandwidth(1013)

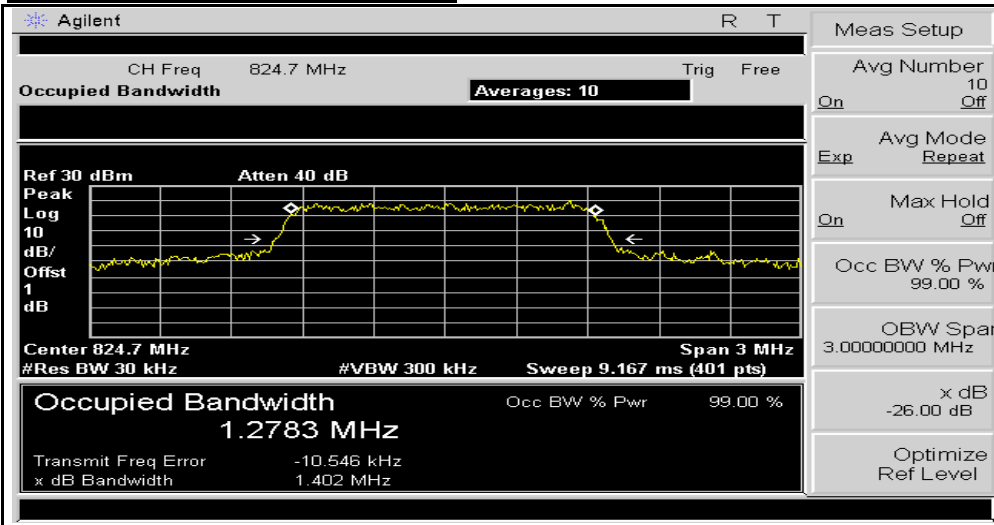

26dB Channel Bandwidth(363)

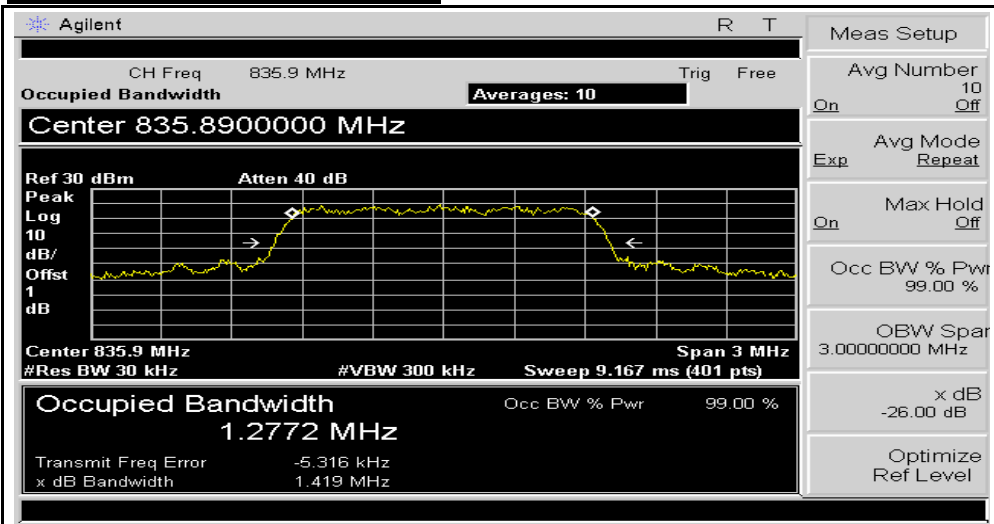

26dB Channel Bandwidth(777)

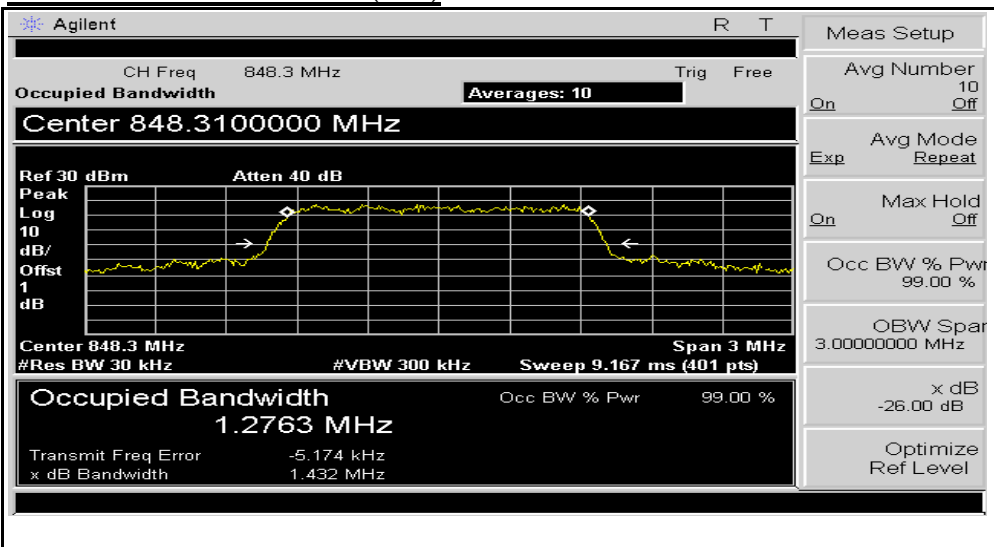

6. Spurious and Harmonic Emission at Antenna Terminal

6.1 Test Procedure

The level of the carrier and the various conducted spurious and harmonic frequencies is measured by means of a calibrated spectrum analyzer. The spectrum is scanned from the lowest frequency generated in the equipment up to 10GHz. Set the RES BW to 1% of the emission bandwidth to show compliance with the -13dBm, limit, in the 1MHz bands immediately outside and adjacent to the top and bottom edges of the frequency block.

For the Out-of-Band measurements a 1MHz RBW was used to scan from 10MHz to 10xfo of the fundamental carrier for all frequency block. A display line was placed at -13dBm to show compliance for spurious, and harmonics.

22.917(f): Mobile emission in base frequency range. The mean power of any emissions appearing in the base station frequency range from cellular mobile transmitter operated must be attenuated to a level not to exceed -80dBm at the transmit antenna connector.

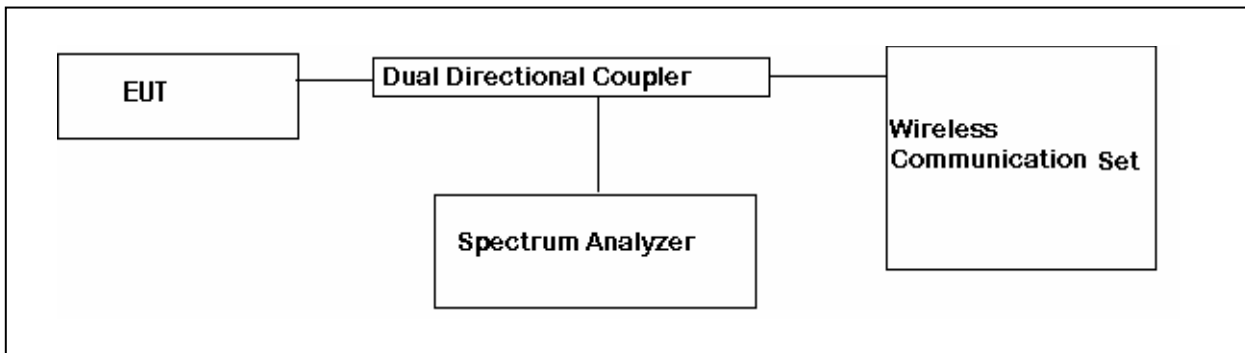

6.2 Test Equipments

The following test equipments are used during tests

Equipment	Manufacturer	Model	Cal. Due Date
Spectrum Analyzer	Agilent	E4407B	2010-02-26
Dual Directional Coupler	HP	778D	2010-02-28
Wireless Communications Test Set	Agilent	E5515C	2010-02-17

6.3 Test Results

CDMA (Spurious Emission: Band Edge)

Channel	Frequency	Result	Limit	Margin
1013	824.70	-15.08	-13.00	2.08
777	848.31	-14.34	-13.00	1.34

CDMA (Spurious Emission: Out of Band)

Channel	Frequency	Result	Limit	Margin
1013	824.70	-24.78	-13.00	11.78
363	835.89	-30.73	-13.00	17.73
777	848.31	-30.15	-13.00	17.15



6.5 Test Plot

PLOTS OF EMISSION (CDMA): BAND EDGE(Ch1013)

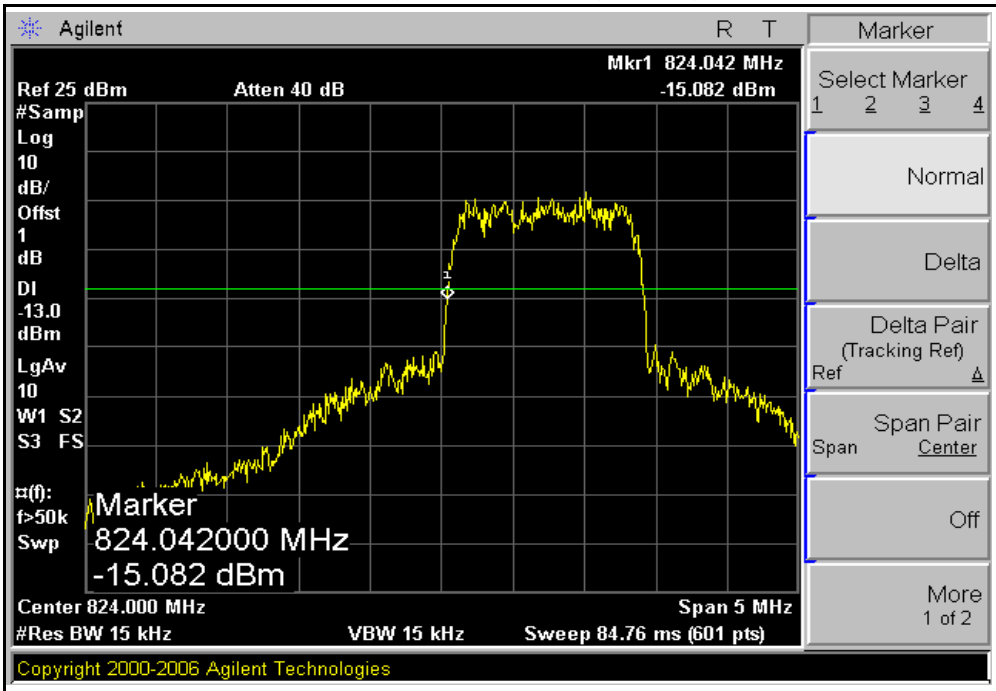

PLOTS OF EMISSION (CDMA): BAND EDGE(Ch777)

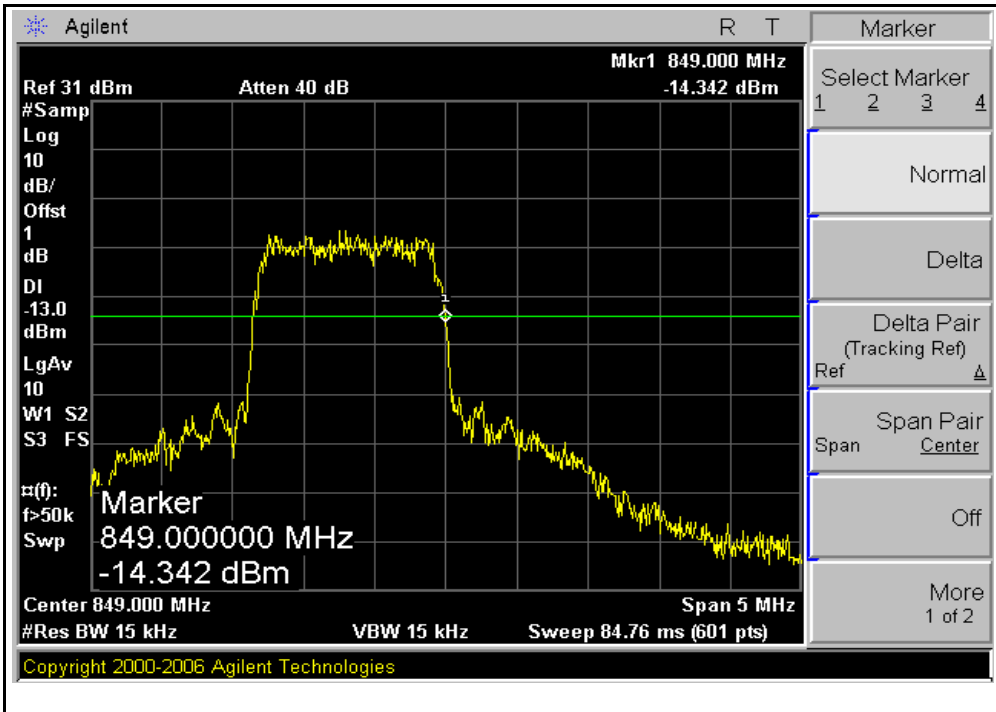



PLOTS OF EMISSION (CDMA): Out of Band(Ch1013)

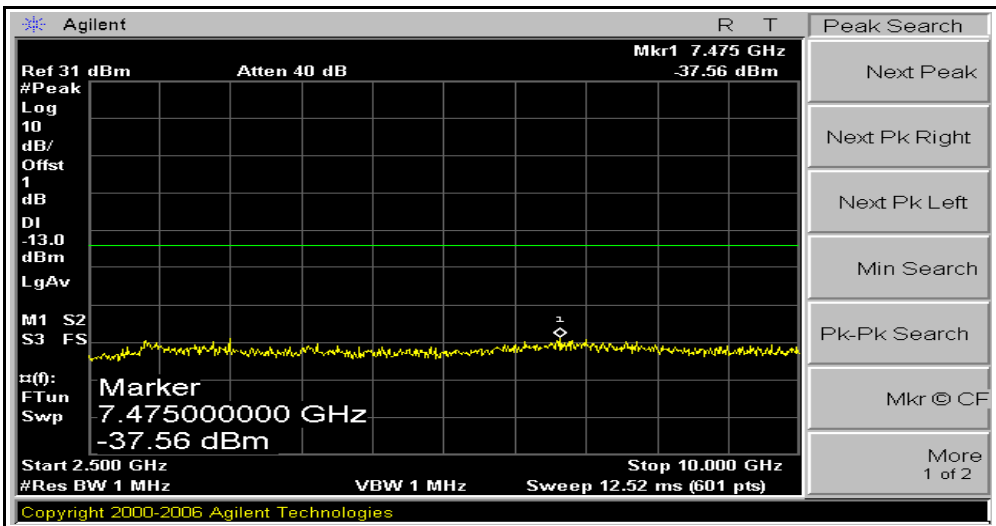
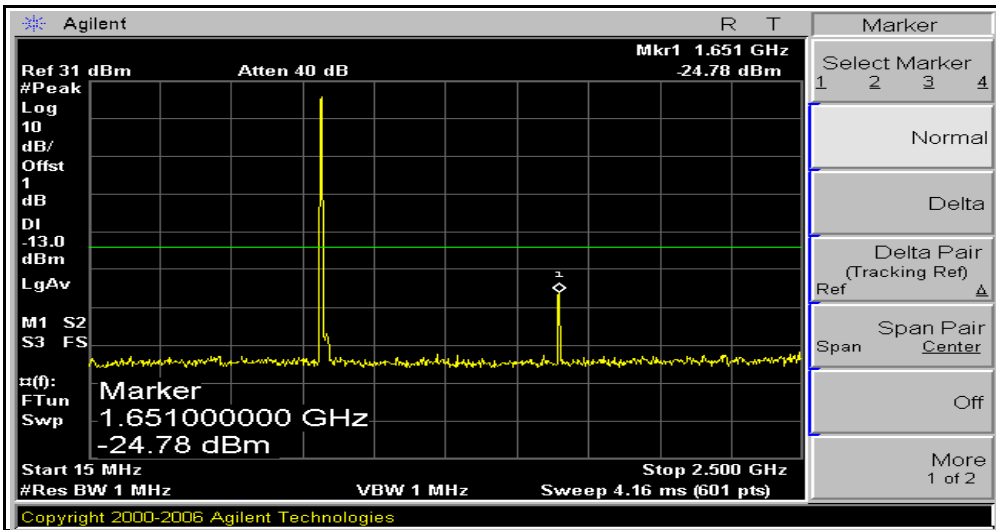

PLOTS OF EMISSION (CDMA): Out of Band(Ch363)

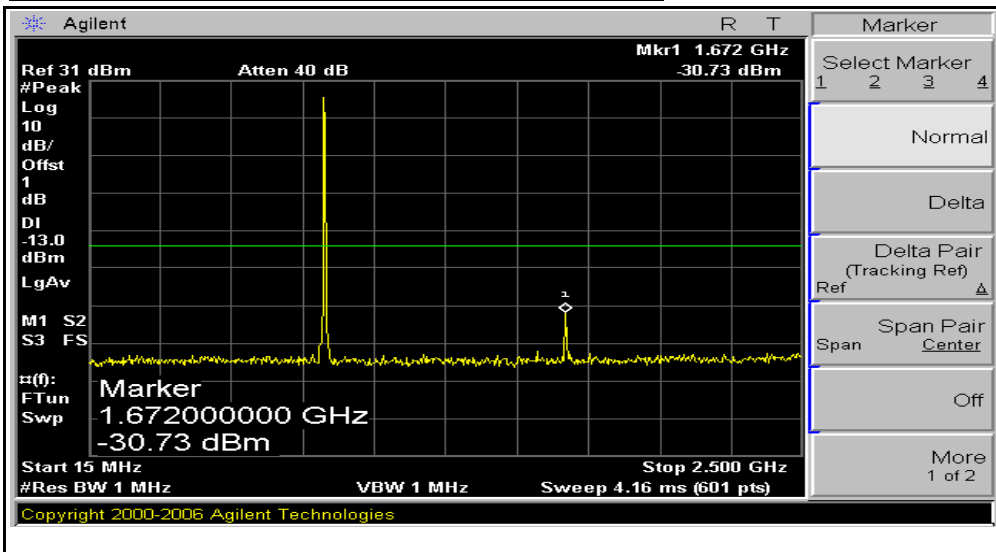

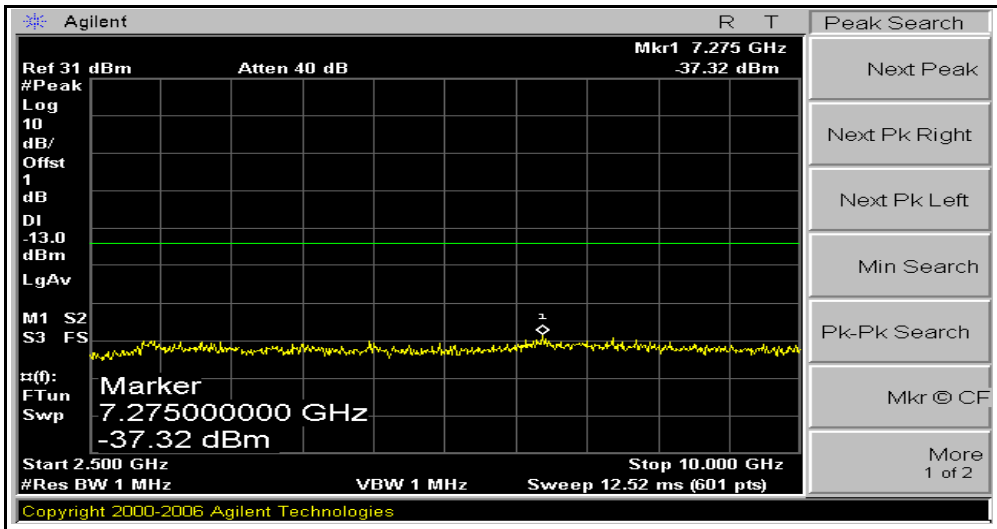

PLOTS OF EMISSION (CDMA): Out of Band(Ch777)

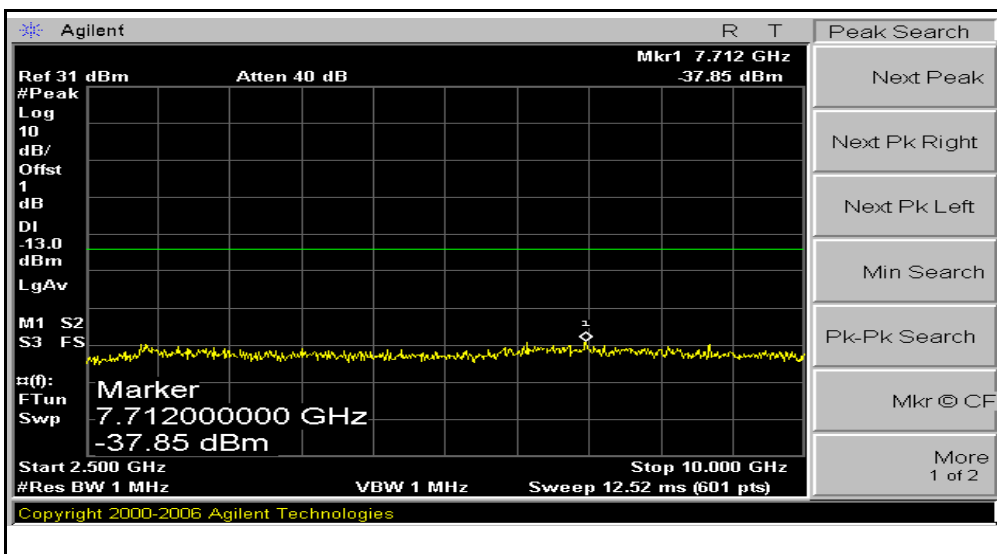
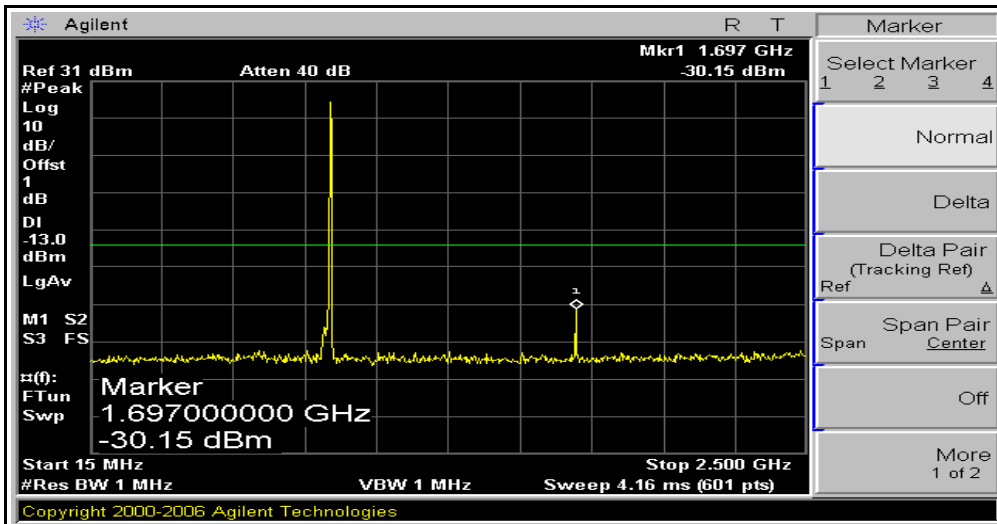



MOBILE EMISSION IN BASE FREQUENCY RANGE (RX BAND)

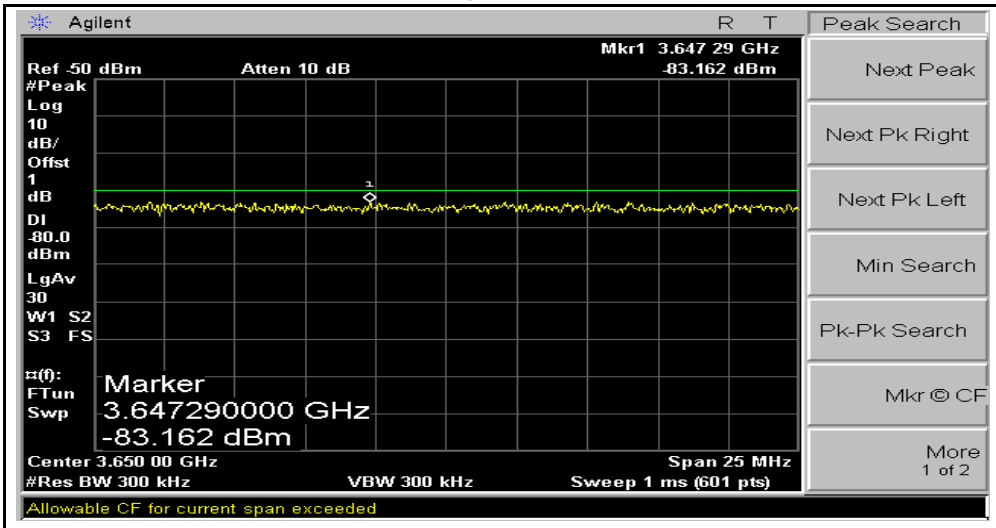

7. Field Strength of Spurious Radiation

7.1 Test Procedure according to ANSI/TIA/EIA 603 Clause 3.2.12 & FCC 22.917(h)

Radiation and harmonic emission are measured outdoors at our 3 meters test range. The equipment under test is placed on a wooden turntable 3 meters from the receive antenna. The receive antenna height and turntable rotations were adjusted for the highest reading on the receive spectrum analyzer (or receiver). A half wave dipole was substituted in place of the EUT. This dipole antenna was driven by a signal generator with the level of the signal generator being adjusted to obtain the same receive spectrum analyzer reading. This level is recorded. For readings above 1GHz, the above procedure is repeated using horn antennas and the difference between the gain of the horn and an isotropic or dipole antenna are taken into consideration.

7.2 Test Equipments

The following test equipments are used during tests

Equipment	Manufacturer	Model	Cal. Due Date
Spectrum Analyzer	ADVANTEST	R3273	2009-06-01
Signal Generator	HP	83620B	2009-09-01
Power Meter	HP	EPM-442A	2009-10-13
Wireless Communications Test Set	Agilent	E5515C	2010-02-17
Pre Amplifier	HP	8449B	2009-12-15
Horn Antenna	SCHWARZBECK	BBHA 9120 D	2009-06-13
Horn Antenna	SCHWARZBECK	BBHA 9120 D	2009-06-13

7.3 Test Setup

Test setup for 30MHz to 1GHz

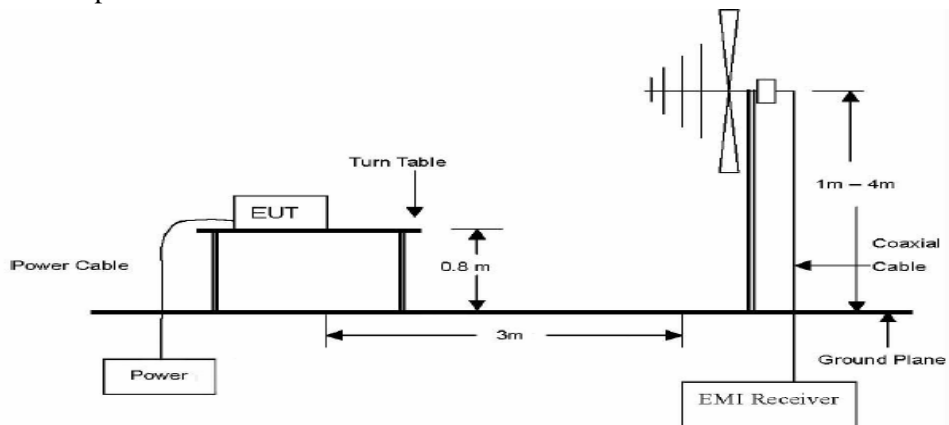

Test setup for above 1GHz

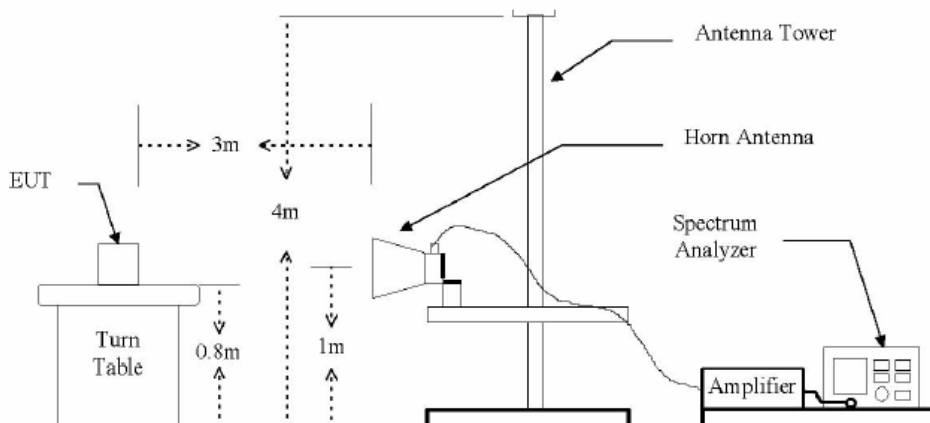



7.4 Test Results

ADAPTER:WPA-162T

CDMA(Ch 1013)

Measured output power: 24.86dBm = 0.306W, Limit: 43+10log₁₀(W)= 37.86dBc

Frequency (MHz)	Receiver Reading(dBuV)	Correction Factor(dB)		ERP(dBm)		dBc	Polarity
		AG(dBd)	CL(dB)	SG Reading	Result		
1649.40	67.66	9.78	11.60	-27.10	-28.92	55.82	V
2474.10	54.88	10.50	14.80	-30.70	-35.00	61.90	H

CDMA(Ch 363)

Measured output power: 24.71dBm = 0.296W, Limit: 43+10log₁₀(W)= 37.71dBc

Frequency (MHz)	Receiver Reading(dBuV)	Correction Factor(dB)		ERP(dBm)		dBc	Polarity
		AG(dBd)	CL(dB)	SG Reading	Result		
1671.78	62.80	9.94	11.70	-32.00	-33.76	59.95	V
2507.67	53.90	10.61	15.00	-31.10	-35.49	61.68	H

CDMA(Ch 777)

Measured output power: 24.00dBm = 0.251W, Limit: 43+10log₁₀(W)= 37.00dBc

Frequency (MHz)	Receiver Reading(dBuV)	Correction Factor(dB)		ERP(dBm)		dBc	Polarity
		AG(dBd)	CL(dB)	SG Reading	Result		
1696.62	64.90	11.80	11.80	-29.80	-29.80	55.81	V
2544.93	54.10	10.98	15.10	-30.80	-34.92	60.93	H



ADAPTER:WPA-170T

CDMA(Ch 1013)

Measured output power: 24.86dBm = 0.306W, Limit: 43+10log₁₀(W)= 37.86dBc

Frequency (MHz)	Receiver Reading(dBuV)	Correction Factor(dB)		ERP(dBm)		dBc	Polarity
		AG(dBd)	CL(dB)	SG Reading	Result		
1649.40	68.02	9.78	11.60	-26.50	-28.32	55.32	V
2507.67	54.72	10.50	14.80	-28.80	-33.10	60.10	H

CDMA(Ch 363)

Measured output power: 24.71dBm = 0.296W, Limit: 43+10log₁₀(W)= 37.71dBc

Frequency (MHz)	Receiver Reading(dBuV)	Correction Factor(dB)		ERP(dBm)		dBc	Polarity
		AG(dBd)	CL(dB)	SG Reading	Result		
1649.40	63.66	9.94	11.70	-31.20	-32.96	59.25	V
2474.10	53.44	10.61	15.00	-31.60	-35.99	62.28	H

CDMA(Ch 777)

Measured output power: 24.00dBm = 0.251W, Limit: 43+10log₁₀(W)= 37.00dBc

Frequency (MHz)	Receiver Reading(dBuV)	Correction Factor(dB)		ERP(dBm)		dBc	Polarity
		AG(dBd)	CL(dB)	SG Reading	Result		
1649.40	63.67	11.80	11.80	-31.10	-31.10	57.11	V
2474.10	53.67	10.98	15.10	-30.70	-34.82	60.83	H



ADAPTER:WPA-152

CDMA(Ch 1013)

Measured output power: 24.86dBm = 0.306W, Limit: 43+10log₁₀(W)= 37.86dBc

Frequency (MHz)	Receiver Reading(dBuV)	Correction Factor(dB)		ERP(dBm)		dBc	Polarity
		AG(dBd)	CL(dB)	SG Reading	Result		
1649.40	68.30	9.78	11.60	-26.50	-28.32	55.22	V
2474.10	54.63	10.50	14.80	-30.90	-35.20	62.10	H

CDMA(Ch 363)

Measured output power: 24.71dBm = 0.296W, Limit: 43+10log₁₀(W)= 37.71dBc

Frequency (MHz)	Receiver Reading(dBuV)	Correction Factor(dB)		ERP(dBm)		dBc	Polarity
		AG(dBd)	CL(dB)	SG Reading	Result		
1671.78	63.81	9.94	11.70	-31.00	-32.76	59.15	V
1696.62	54.17	10.61	15.00	-30.80	-35.19	61.58	H

CDMA(Ch 777)

Measured output power: 24.00dBm = 0.251W, Limit: 43+10log₁₀(W)= 37.00dBc

Frequency (MHz)	Receiver Reading(dBuV)	Correction Factor(dB)		ERP(dBm)		dBc	Polarity
		AG(dBd)	CL(dB)	SG Reading	Result		
1696.62	64.04	11.80	11.80	-30.80	-30.80	57.01	V
2544.93	54.08	10.98	15.10	-30.30	-34.42	60.63	H

8. Frequency stability

8.1 Test Procedure

The frequency stability of the transmitter is measured by:

- a) **Temperature:** The temperature is varied from -30 to +60 using an environmental chamber.
- b) **Primary Supply Voltage:** The primary supply voltage is varied from 85% to 115% of the voltage normally at the input to the device or at the power supply terminals if cables are not normally supplied.

The frequency stability shall be sufficient to ensure that the fundamental emission stays within the authorized frequency block. The frequency stability of the transmitter shall be maintained within ± 2.5 ppm of the center frequency.

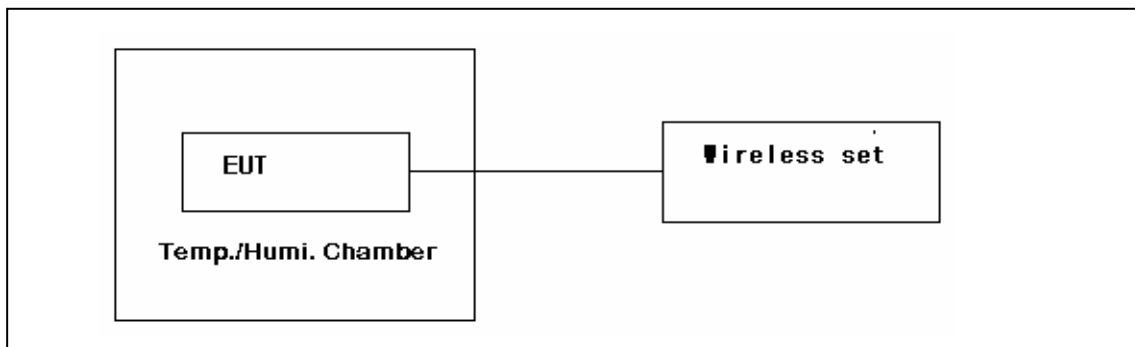

8.2 Test Equipments

The following test equipments are used during tests

Equipment	Manufacturer	Model	Cal. Due Date
Communications Test	Agilent	E5515C	2010-02-17
DC Power Supply	INTERACT	AK-5007	2010-02-28
Tem/Hum Chamber	TABAI ESPEC CORP	PSL-2GT	2010-02-10



8.3 Test Results

Operating Frequency :	835,890,000
Channel :	363
Reference Voltage :	110.00
Deviatin Limit :	0.00025

Voltage (%)	Power (VDC)	Temperature ()	Frequency (Hz)	Deviation
100	110.00	+20 (Ref)	835,890,003	0.000000
100		-30	835,889,977	0.000003
100		-20	835,889,978	0.000003
100		-10	835,889,977	0.000003
100		0	835,889,977	0.000003
100		10	835,889,977	0.000003
100		20	835,890,003	0.000000
100		25	835,889,985	0.000002
100		30	835,889,975	0.000003
100		40	835,889,977	0.000003
100		50	835,889,978	0.000003
100		60	835,889,975	0.000003
85		93.5	20	835,889,970
115	126.5	20	835,889,977	0.000003
Batt EndPoint	85.00	20	835,889,971	0.000004