



Underwriters Laboratories Inc.

www.ul.com/emc

www.ulk.co.kr

Project: 11CA14436

File: TC8329

Report: 11CA14436-FCC

Date: April 5, 2011

Model: Ethernet Access Residential Unit 1212

FCC Certification Report

For

WDM-PON ONT

LG-Ericsson Co., Ltd.

**LG R&D Complex 533 Hoge-1dong, Dongan-gu, Anyang-si, Kyungki-do,
431-749, Korea**

Copyright © 2005 Underwriters Laboratories Inc.

UL Korea, Ltd . authorizes the above-named company to reproduce this Report provided it is reproduced in its entirety.

UL Korea, Ltd
33rd FL, Gangnam Finance Center, 737
Yeoksam-dong, Gangnam-gu, Seoul
135-984 Korea
Tel: +82.2.2009.9000, Fax:+82.2.2009.9405

**A not-for-profit organization dedicated
to public safety and committed to
quality service for over 100 years**

TEST REPORT DETAILS

Test Report No. 11CA14436-FCC
Tests Performed By: UL Korea Ltd.
33rd FL. Gangnam Finance Center, 737 Yeoksam-dong,
Kangnam-ku, Seoul, 135-984, Korea
Test site: LG-Ericsson Co.Ltd.(Test Laboratory)
299, Kongdan-dong, Gumi-si, Kyungsangbuk-do, Korea
Applicant: LG-Ericsson Co.Ltd
LG R&D Complex 533 Hogue-1dong, Dongan-gu, Anyang-si,
Kyungki-do, 431-749, Korea
Applicant Contact: Mr. Young-Ho Son
Title: Chief Research Engineer
Phone: 82-31-450-4263
E-mail: youngho.son@lgericsson.com
Test Report Date: April 5, 2011
Product Type: WDM-PON ONT
FCC ID: TUIEARU1212R5
Product standards: FCC Part 15 Subpart B Class B
Equipment Code: JBP
FCC Classification : Class B Computing Device Peripheral
FCC Procedure : Certification
Model Number: Ethernet Access Residential Unit 1212
Additional model Number: Ethernet Access Residential Unit 1211
This report covers multi-model name which is identical to the
basic model according to the manufacturer's specification.
Trade Name: 
Sample Serial Number: None (Proto type)
Sample Receive Date: March 22, 2011
Testing Start Date: March 22, 2011
Date Testing Complete: March 25, 2011
Overall Results: PASS

UL Korea Ltd. reports apply only to the specific samples tested under stated test conditions. All samples tested were in good operating condition throughout the entire test program. It is the manufacturer's responsibility to assure that additional production units of this model are manufactured with identical electrical and mechanical components. UL Korea Ltd. shall have no liability for any deductions, inferences or generalizations drawn by the client or others from UL Korea Ltd. issued reports.

TEST SUMMARY

Test Result

Requirement – Test	Reference standards	Result	Verdict
Conducted Disturbance at the mains ports	FCC Part 15 Subpart B, Class B ANCI C63.4-2009	Pass	Complied
Radiated Disturbance		Pass	Complied

The tests listed in the Summary of Testing section of this report have been performed and the results recorded by UL Korea, Ltd. in accordance with the procedures stated in each test requirement and specification. The applicant determined the list of tests performed were applicable to the Equipment Under Test. As a result, the subject product has been verified to comply or not comply as noted in the Summary of Testing with each test specification. The test results relate only to the items tested.

The equipment under test has

- met the technical requirements
- not met the technical requirements



Tested by
Sung Hoon, Baek, Project Engineer
Conformity Assessment Services - 3014ASEO
UL Korea Ltd.
April 5, 2011



Reviewed by
Jeawoon, Choi, Senior Project Engineer
Conformity Assessment Services - 3014ASEO
UL Korea Ltd.
April 5, 2011

Report Directory

1. EQUIPMENT UNDER TEST(EUT).....	5
1.1 EQUIPMENT DESCRIPTION.....	5
1.2 EQUIPMENT MARKING PLATE.....	6
1.3 EQUIPMENT USED DURING TEST	7
1.4 INPUT/OUTPUT PORTS	7
1.5 EUT INTERNAL OPERATING FREQUENCIES:	7
1.6 POWER INTERFACE:.....	7
2. EUT OPERATION MODES:	8
3. EUT CONFIGURATIONS:	8
4. CONDUCTED EMISSION.....	9
5. RADIATED EMISSION	12
APPENDIX A_ACCREDITATIONS AND AUTHORIZATIONS.....	16
APPENDIX B_MEASUREMENT UNCERTAINTIES.....	17

1. EQUIPMENT UNDER TEST(EUT)

1.1 Equipment Description

The EA 1100 solution goes beyond traditional Fiber to the Home (FTTH) or Ethernet to the Home (ETTH), providing Ethernet over Wavelength Division Multiplexing-Passive Optical Networks (WDM-PON). The EA 1100 delivers a dedicated symmetrical upstream and downstream bandwidth capacity that is orders of magnitude above that of Time Division Multiplexing (TDM)-based PON solutions, while overcoming the fiber availability and/or termination density challenges associated with making Ethernet and FTTH an accessible reality to any number of end-users.

In an Ethernet over WDM access solution, a single wavelength is re-directed to an end user from the central office through a passive wavelength router located in the outside plant (OSP). Unlike TDM PON, wavelengths are point-to-point and independent of each other, enabling symmetrical bandwidth from the distribution hub to the home.







The EA 1100 supports 32 wavelengths of 100 Mbps or 16 wavelengths of 1Gbps on a single fiber. With a reach of 20 km, each point-to-point connection covers the vast majority of residential deployments and enables the capture of business services and wireless backhaul traffic. About service application, it can be set to 100 Mbps for residential service or can be set to 1 Gbps to service a large enterprise or multi-dwelling building.

Equipped with passive wavelength filters and “plug-n-play” colorless Optical Network Terminals (ONTs), the EA 1100 solution is free of the deployment, operations, and engineering complexities associated with other WDM PON systems..







The following are the technical specification of the ONT product

Optical Interface	
Optical cable	Single mode optical fiber
Line Rate	1.25Gbps
Optical Interface	SC/APC connetor
Optic Transceiver	C band : Uplink, L band :Downlink
Power	12V 1A
Ethernet Port	
Operation mode	Fast Ethernet / Auto-Negotiation Mode
Electrical interface	RJ-45 connector
POTS port	
Electrical interface	RJ-11 connector

1.2 Equipment Marking Plate

 Ethernet Access Residential Unit 1212 12 V; 1 A      www.lgericsson.com	<p>This product complies with FDA performance standards for laser products except for deviations pursuant to laser notice No. 50, dated June 24, 2007, and with IEC 60825-1 as a Class 1 laser product. This device complies with part 15 of the FCC rules. Operation is subject to the following two conditions: (1) this device may not cause harmful interference, and (2) this device must accept any interference received, including interference that may cause undesired operation.</p> <p>This Class B digital apparatus complies with Canadian ICES-003. Cet appareil numérique de la classe B est conforme à la norme NMB-003 du Canada.</p> <p>FCC ID : TUIEARU1212R5</p> <p>Made in / Fabriqué au Korea</p>
--	--

EARU1212

 Ethernet Access Residential Unit 1211 12 V; 1 A      www.lgericsson.com	<p>This product complies with FDA performance standards for laser products except for deviations pursuant to laser notice No. 50, dated June 24, 2007, and with IEC 60825-1 as a Class 1 laser product. This device complies with part 15 of the FCC rules. Operation is subject to the following two conditions: (1) this device may not cause harmful interference, and (2) this device must accept any interference received, including interference that may cause undesired operation.</p> <p>This Class B digital apparatus complies with Canadian ICES-003. Cet appareil numérique de la classe B est conforme à la norme NMB-003 du Canada.</p> <p>FCC ID : TUIEARU1212R5</p> <p>Made in / Fabriqué au Korea</p>
--	--

EARU1211

1.3 Equipment Used During Test

Use*	Product Type	Manufacturer	Model	Comments
EUT	WDM-PON ONT	LG-Ericsson Co., Ltd.	Ethernet Access Residential Unit 1212	-
AE	AC/DC Adaptor	Weihai Sunlin Electronics Co., Ltd.	SR693J01	-
SIM	Data Quality Analyzer	Anritsu	MD1230A	-
SIM	RN	LG-Ericsson Co., Ltd.	AWG	-
SIM	OLT Shelf	LG-Ericsson Co., Ltd.	EAST1100 OLT Shelf	MC, SW, PI-
SIM	WDM-PON ONU	LG-Ericsson Co., Ltd.	WP-1104	-

* Note: **EUT** - Equipment Under Test , **AE** - Auxiliary/Associated Equipment, **SIM** - Simulator (Not Subjected to Test)

1.4 Input/Output Ports

Port #	Name	Type*	Cable Length	Cable Shielded	Comments
1	Mains Power Input	AC	1.5 m	Unshielded	Connected to Main power
2	Optic	N/E	20.0 m	Optical	Connected to RN
3	LAN Port	TP	20.0 m	Unshielded	Connected to Data Quality Analyzer : 4 ports
4	POTS	TP	> 10m	Unshielded	Connected to Telephone/Indoor

Note:
 *AC = AC Power Port DC = DC Power Port N/E = Non-Electrical
 I/O = Signal Input or Output Port (Not Involved in Process Control) TP = Telecommunication Ports

1.5 EUT Internal Operating Frequencies:

Frequency (MHz)	Description	Frequency (MHz)	Description
0.96	I ² C	25.0	PHY
12.5	MDC CLK	50.0	Main Processor
125.0	GTX CLK	-	-

1.6 Power Interface:

Mode #	Voltage (V)	Current (A)	Power (W)	Frequency (DC/AC-Hz)	Phases (#)	Comments
Rated	100-240V	1	-	AC 50/60HZ	Single Phase	Input of AC/DC Adaptor
1	120Vac	-	-	60HZ	Single Phase	Input of AC/DC Adapter

2. EUT Operation Modes:

Mode #	Description
1	<p>Communication link and Data transmission function</p> <p>Emission & Immunity tests have been performed by establishing optic communication links between ONT and OLT PI through RN interface. To simulator and check the optic communication link quality, the Data Quality Analyzer (MD1230A) was used for Ethernet packet data sending / receiving of 1.25Gbps LAN port. Telephone was connected to POTS port and Phone service was established</p>

3. EUT Configurations:

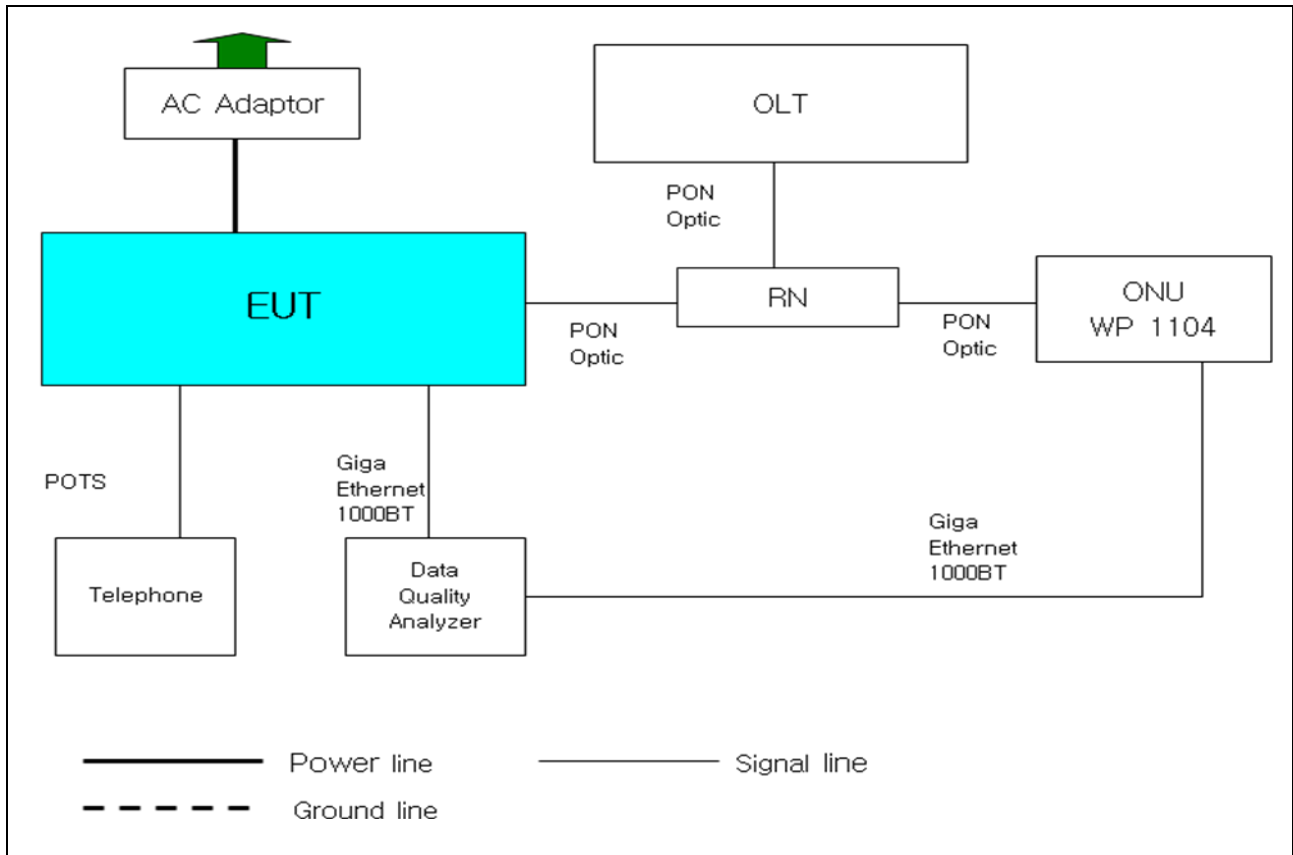

Note : EUT (WDM-PON ONT) have the operation function that supply the subscriber with fast Ethernet(125Mbps) port. The Ethernet switching function of EUT is performed that service Ethernet traffic from a subscriber is switched to optic signal through the Network device optic port.

MD1230A(Anritsu) functions as Data Quality Analyzer, is connected to fast Ethernet port of EUT with the Auto negotiation method which provide the function of the link layer connection of 125M bps speed and analyze the normal operation function through generating the IP packet signal of Ether frame and analyzing the switched packet signal from EUT. Data Quality Analyzer should be configured for the normal operating system and maximum emission condition during the test period.

4. CONDUCTED EMISSION

TEST: Limits of mains terminal disturbance voltage				
Method	Measurements were made on a ground plane that extends 1-meter minimum beyond all sides of the system under test. All power was connected to the system through Artificial Mains Network (AMN). Conducted voltage measurements on mains lines were made at the output of the AMN.			
Test Environment				
Parameters recorded during the test	Laboratory Ambient Temperature		21 °C	
	Relative Humidity		33 %	
	Frequency range on each side of line		Measurement Point	
Fully configured sample scanned over the following frequency range	150kHz to 30MHz		Mains Power Input	
Limits - Class A				
Frequency (MHz)	Limit (dB μ V)			
	Quasi-Peak	Results	Average	Results
0.15 to 0.50	79	N/A	66	N/A
0.50 to 30	73	N/A	60	N/A
Limits - Class B				
Frequency (MHz)	Limit (dB μ V)			
	Quasi-Peak	Results	Average	Results
0.15 to 0.50	66 to 56	Pass	56 to 46	Pass
0.50 to 5	56	Pass	46	Pass
5 to 30	60	Pass	50	Pass
Supplementary information: None				

Test Equipment Used					
Description	Manufacturer	Model	Identifier	Cal. Date	Cal. Due
Test Receiver	Rohde&Schwarz	ESS	845637/014	2010.11.29	2011.11.29
LISN	EMCO	3825/2	9502-2334	2010.08.12	2011.08.12
ISN	T800	Teseq GmbH	26085	2010.06.11	2011.06.11

Table 1. Test data for conducted emission :

Test Frequency (MHz)	Correction Factor		Reading value (dBuV)		Line	Level (dBuV)		Limit (dBuV)		Margin (dB)	
	Cable	LISN	QP	AV		QP	AV	QP	AV	QP	AV
0.185	0.03	0.10	40.245	32.135	L1	40.37	32.26	65	55	24.63	22.74
0.245	0.03	0.07	37.958	34.288	L1	38.06	34.39	63.28	53.28	25.22	18.89
0.610	0.05	0.04	31.81	29.59	L1	31.9	29.68	56	46	24.1	16.32
2.925	0.12	0.06	35.542	28.192	L2	35.72	28.37	56	46	20.28	17.63
7.560	0.20	0.10	45.479	40.529	L2	45.78	40.83	60	50	14.22	9.17
7.745	0.21	0.10	45.225	46.325	L1	45.53	46.63	60	50	14.47	3.37

Note:
 1. Margin (dB)= Limit (dBuV) - Level (dBuV)
 2. If no frequencies are specified in the tables, no measurement for quasi-peak or average was necessary.

Figure 1. Graphical representation of conducted emissions

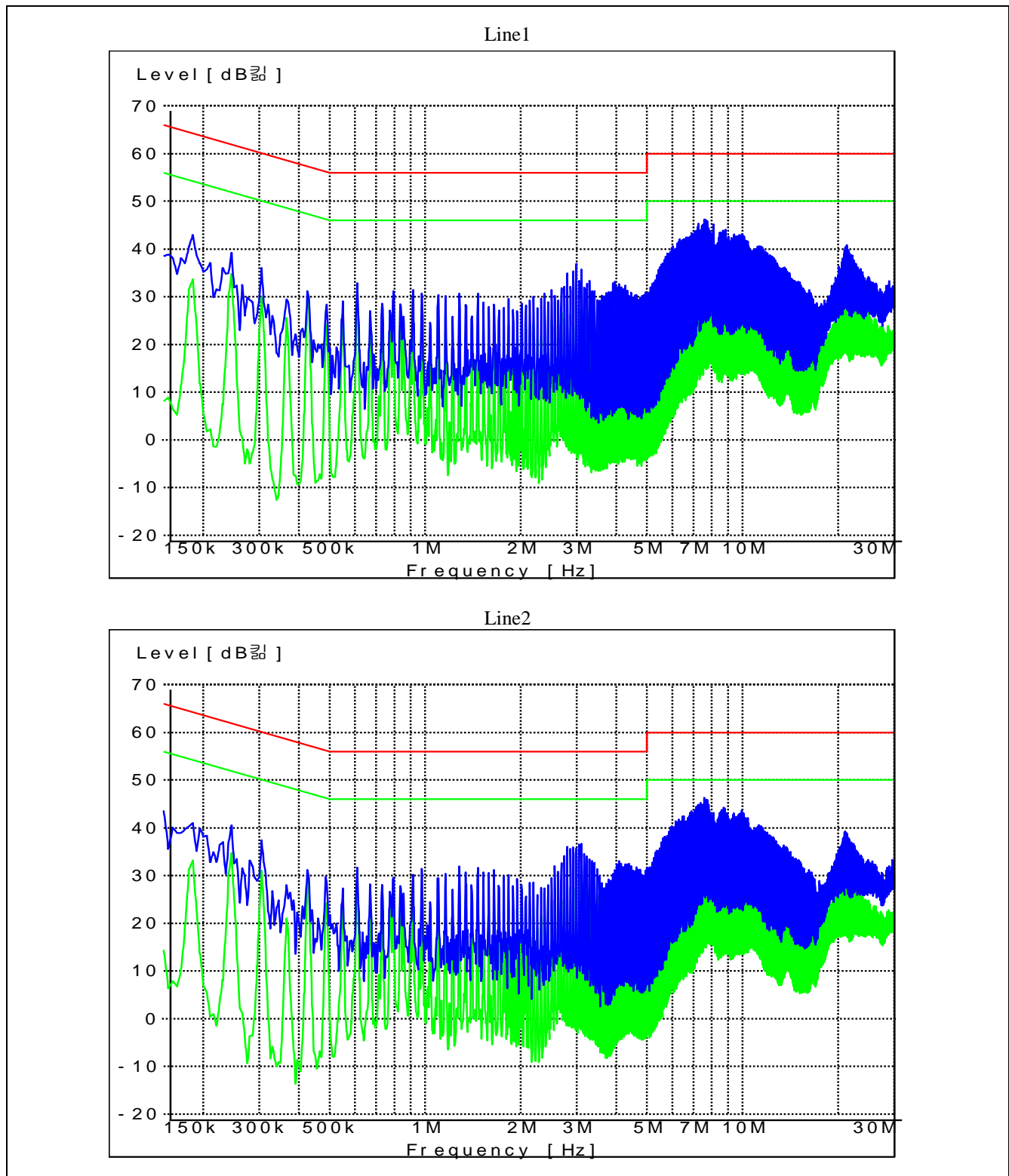

5. RADIATED EMISSION

TEST: Limits for radiated disturbance		
Method	Measurements were made at 10m Anechoic chamber that complies to CISPR 16/ANSI C63.4. Preliminary (peak) measurements were performed at an antenna to EUT separation distance of 10-meter and 3-meter. The EUT was rotated 360° about its azimuth with the receive antenna located at 1, 2, 3 and 4 meter heights in both horizontal and vertical polarities. Final measurements (quasi-peak or average as noted) were then performed by rotating the EUT 360° and adjusting the receive antenna height from 1 to 4-meters. All frequencies were investigated in both horizontal and vertical antenna polarity, where applicable.	
TEST ENVIRONMENT		
Parameters recorded during the test	Laboratory Ambient Temperature	21 °C
	Relative Humidity	33 %
Fully configured sample scanned over the following frequency range	Frequency range	Measurement Point
	30MHz – 2GHz	Product Enclosure
Limits - Class A		
Frequency (MHz)	Limit (dBµV/m)	
	Quasi-Peak	Results
30 to 230	40	N/A
230 to 1000	47	N/A
1000 to 2000	60/80(AV/Peak, 3m distance)	N/A
Limits - Class B		
Frequency (MHz)	Limit (dBµV/m)	
	Quasi-Peak(10m distance)	Results
30 to 230	30	Pass
230 to 1000	37	Pass
1000 to 2000	54/74(AV/Peak, 3m distance)	Pass
Supplementary information:		

Test Equipment Used					
Description	Manufacturer	Model	Identifier	Cal. Date	Cal. Due
EMI Test Receiver	Rohde&Schwarz	ESI	834000/002	2010.11. 29	2011.11.29
BiconiLog Antenna	EMCO	3142B	9910-1432	2010.08. 13	2011.08.13
Horn Antenna	Schwarzbeck	BBHA9120D	9120D-539	2010.07.14	2011.07.14
Turn Table	EMCO	1072	N/A	N/A	N/A
Antenna Mast	EMCO	1084	862557/010	N/A	N/A
A/M&T/T Controller	EMCO	1090	N/A	N/A	N/A

Table 3. Radiated emission Test data :

30MHz ~ 1GHz_10m distance

Test Frequency (MHz)	Meter Reading (dBuV)	Polarity (V/H)	Azimuth (Deg.)	Antenna Height (cm)	Cable Loss (dB)	Antenna Factor (dB/m)	Level dBuV/m	Limit dBuV/m	Margin (dB)
51.76	14.622	V	239	100	0.98	7.55	23.15	30	6.85
124.96	14.5725	V	89	100	1.54	6.22	22.33	30	7.67
199.96	13.63	V	302	100	1.93	8.98	24.54	30	5.46
224.96	13.825	V	349	100	2.06	10.69	26.57	30	3.43
249.96	15.35	V	27	100	2.18	12.40	29.93	37	7.07
274.96	9.41	V	345	100	7.82	12.93	30.16	37	6.84
299.96	4.96	V	360	100	13.46	13.46	31.88	37	5.12
499.96	9.6	H	313	135	3.04	18.65	31.29	37	5.71
624.96	7.7925	H	355	123	3.41	21.18	32.38	37	4.62
749.96	8.74	V	360	198	3.73	22.47	34.94	37	2.06

Above 1GHz_3m distance.

Frequency (GHz)	Reading(AV) (dBuV)		Pol.	Ant. Height (cm)	Correction Factor			Limit (dBuV/m)	Level (dBuV/m)	
	Peak	AV			Ant. (dB/m)	Cable (dB)	Amp. (dB)		Peak	AV
1.000	46.38	36.70	V	100	25.00	4.43	-30.0	54.0	45.81	36.13
1.250	48.25	39.31	H	100	25.58	4.88	-30.0	54.0	48.71	39.77
1.370	47.40	38.74	H	100	25.86	5.06	-30.0	54.0	48.32	39.66
1.500	47.09	41.25	H	100	26.16	5.29	-30.0	54.0	48.54	42.70
1.625	46.73	38.97	V	100	26.45	5.54	-30.0	54.0	48.72	40.96
1.750	47.25	38.05	H	100	26.74	5.79	-30.0	54.0	49.78	40.58

Figure 2. Graphical representation of Radiated emission
30MHz~1GHz

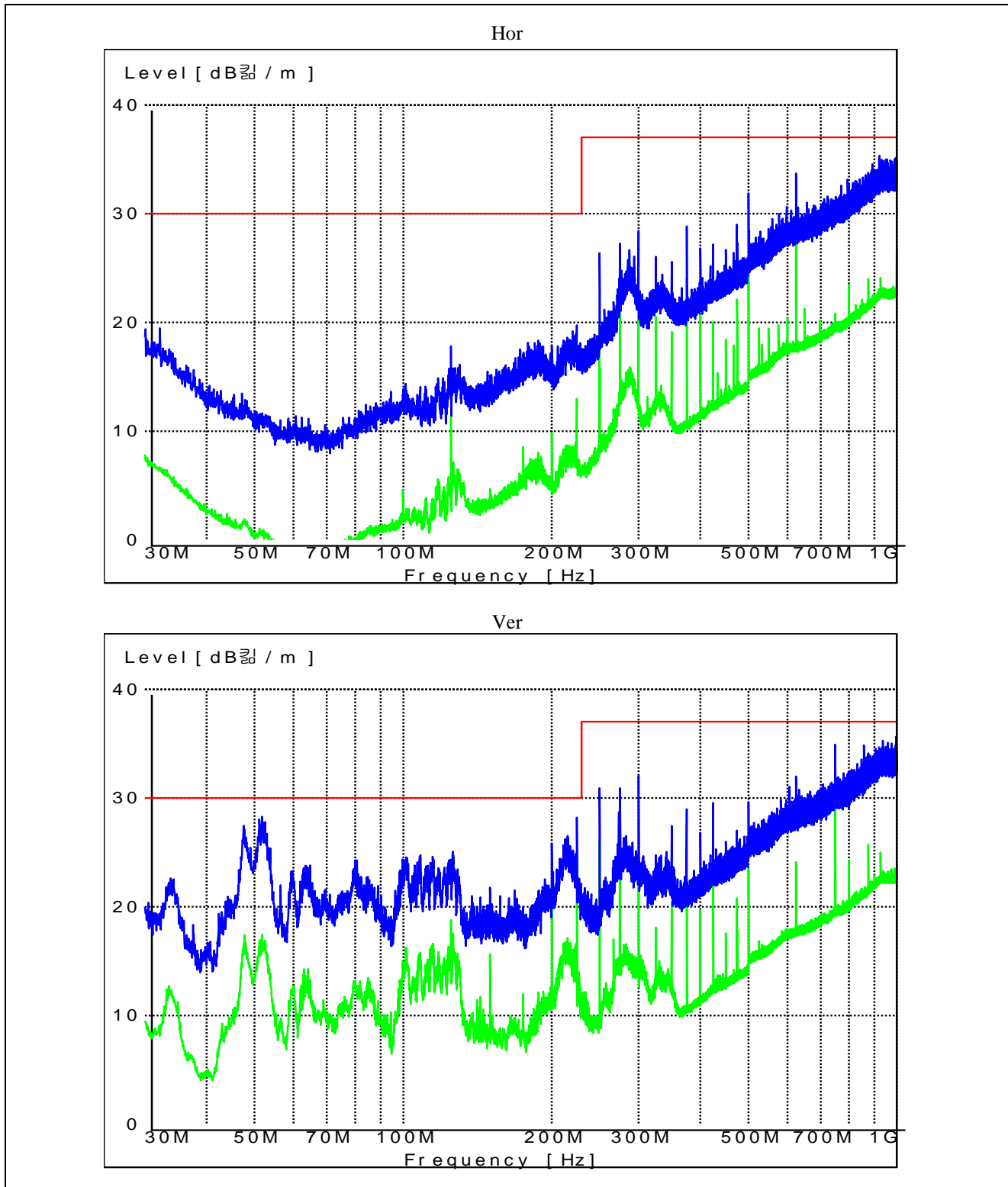

1GHz~2GHz

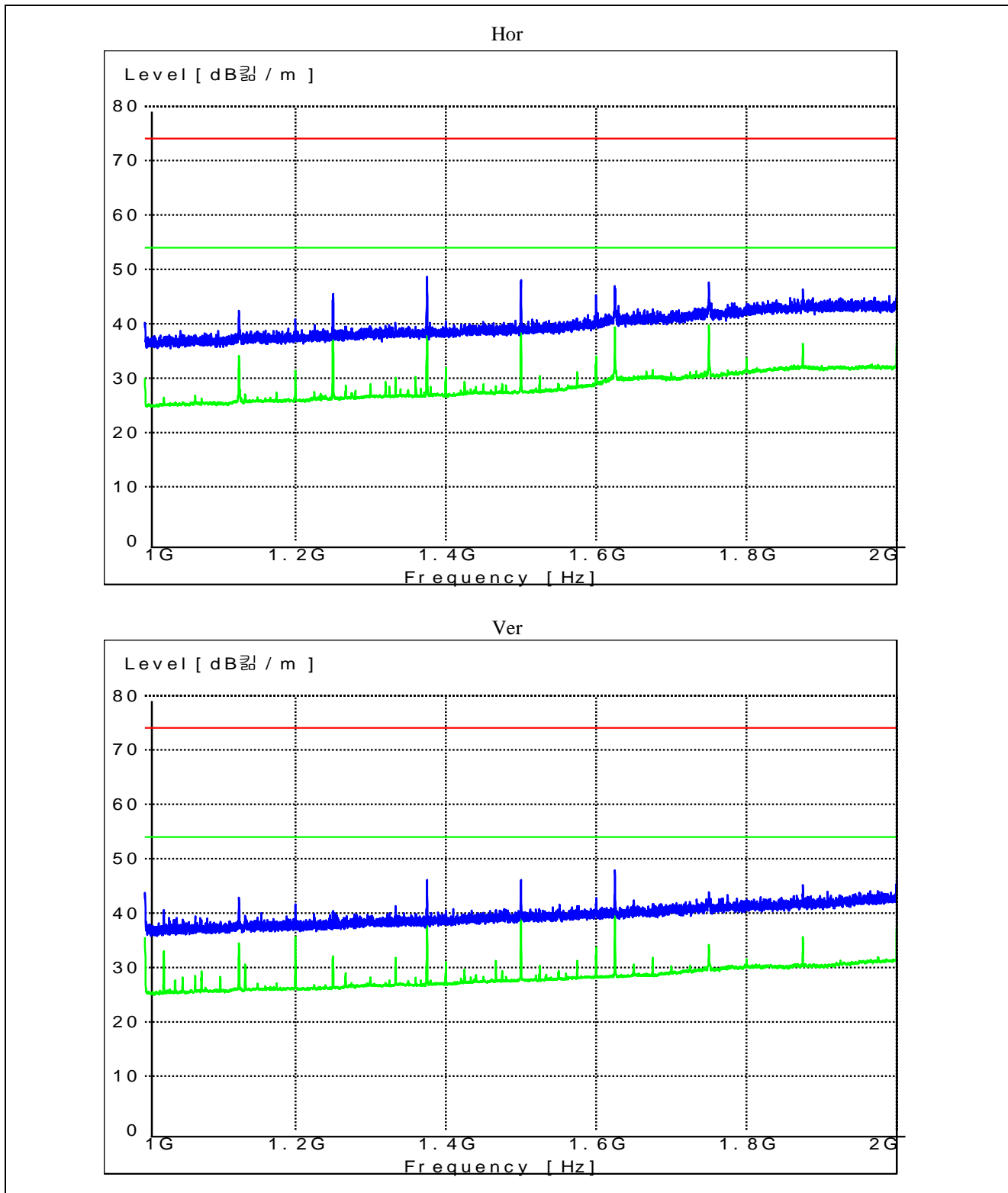

Appendix A_Accreditations and Authorizations



KCC: Designated as a testing laboratory by Radio Research Agency in accordance with the Regulation on Designation of Testing Laboratory for Information and Communication Equipment. Registration No. : KR020



FCC: Details of the measurement facilities used for these tests have been filed with the Federal Communications Commission's Laboratory in Columbia, Maryland and accepted in a letter dated Aug. 17, 2010 (Reg. No. 90762). As a Conformity Assessment Body (CAB), our organization is designated to perform compliance testing on equipment subject to Declaration Of Conformity (DOC) and Certification under Part 15 and 18 of the Commission's Rules in a letter dated Jul. 1, 2008 (Reg. No. 614154).

Appendix B_Measurement Uncertainties

Test	Uncertainty
Radiated Emissions	±4.08 dB
Conducted Emissions	±2.0 dB