



TEST REPORT

Test Report No. : UL-RPT-RP10895558JD02G V2.0

Manufacturer : Bang & Olufsen a/s
Model Name : WUS-AC08V
FCC ID : TTUWUSAC08V
Technology : WLAN (802.11a/n/ac)
Test Standard(s) : FCC Parts 15.207, 15.209(a) & 15.407

1. This test report shall not be reproduced in full or partial, without the written approval of UL VS LTD.
2. The results in this report apply only to the sample(s) tested.
3. The sample tested is in compliance with the above standard(s).
4. The test results in this report are traceable to the national or international standards.
5. Version 2.0 supersedes all previous versions.

Date of Issue: 19 December 2016

Checked by:

Ian Watch
Senior Engineer, Radio Laboratory

Company Signatory :

Sarah Williams
Senior Engineer, Radio Laboratory
UL VS LTD



This laboratory is accredited by UKAS.
The tests reported herein have been
performed in accordance with its terms
of accreditation.

UL VS LTD

Pavilion A, Ashwood Park, Ashwood Way, Basingstoke, Hampshire, RG23 8BG, UK
Telephone: +44 (0)1256 312000
Facsimile: +44 (0)1256 312001

This page has been left intentionally blank.

Table of Contents

1. Customer Information.....	4
2. Summary of Testing.....	5
2.1. General Information	5
2.2. Summary of Test Results	5
2.3. Methods and Procedures	6
2.4. Deviations from the Test Specification	6
3. Equipment Under Test (EUT)	7
3.1. Identification of Equipment Under Test (EUT)	7
3.2. Description of EUT	7
3.3. Modifications Incorporated in the EUT	7
3.4. Additional Information Related to Testing	8
3.5. Support Equipment	9
4. Operation and Monitoring of the EUT during Testing	13
4.1. Operating Modes	13
4.2. Configuration and Peripherals	13
4.3. Power Settings Used During Testing	16
5. Measurements, Examinations and Derived Results.....	17
5.1. General Comments	17
5.2. Test Results	18
5.2.1. Transmitter AC Conducted Spurious Emissions	18
5.2.2. Transmitter 26 dB Emission Bandwidth	24
5.2.3. Transmitter Minimum 6 dB Bandwidth (5.725-5.85 GHz band)	63
5.2.4. Transmitter Duty Cycle	73
5.2.5. Transmitter Maximum Conducted Output Power	83
5.2.6. Transmitter Maximum Power Spectral Density	113
5.2.7. Transmitter Out of Band Radiated Emissions	128
5.2.8. Transmitter Band Edge Radiated Emissions	144
6. Measurement Uncertainty	187
7. Report Revision History	188
Appendix 1. Part 15.407(b)(4) Emission Limits.....	189

1. Customer Information











Company Name:	Bang & Olufsen A/S
Address:	Peter Bangs Vej 15 7600 Struer Denmark

2. Summary of Testing

2.1. General Information

Specification Reference:	47CFR15.407 and 47CFR15.403
Specification Title:	Code of Federal Regulations Volume 47 (Telecommunications): Part 15 Subpart E (Unlicensed National Information Infrastructure Devices) – Sections 15.403 and 15.407
Site Registration:	209735
Location of Testing:	UL VS LTD, Unit 3 Horizon, Wade Road, Kingsland Business Park, Basingstoke, Hampshire, RG24 8AH, United Kingdom
Test Dates:	15 October 2015 to 27 July 2016

2.2. Summary of Test Results

FCC Reference (47CFR)	Measurement	Result
Part 15.207	Transmitter AC Conducted Emissions	
Part 15.403(i)	Transmitter 26 dB Emission Bandwidth	
Part 15.407(e)	Transmitter Minimum 6 dB Bandwidth (5.725-5.85 GHz band)	
Part 15.35(c)	Transmitter Duty Cycle	Note 1
Part 15.407(a)(1)(iv)	Transmitter Maximum Conducted Output Power (5.15-5.25 GHz band)	
Part 15.407(a)(3)	Transmitter Maximum Conducted Output Power (5.725-5.85 GHz band)	
Part 15.407(a)(1)(iv)	Transmitter Peak Power Spectral Density (5.15-5.25 GHz band)	
Part 15.407(a)(3)	Transmitter Peak Power Spectral Density (5.725-5.85 GHz band)	
Part 15.407(b)/15.209(a)	Transmitter Out of Band Radiated Emissions	
Part 15.407(b)/15.209(a)	Transmitter Band Edge Radiated Emissions	
Part 15.407(g)	Transmitter Frequency Stability (Temperature & Voltage Variation)	Note 2
Part 15.407(h)(1)	Transmitter Power Control	Note 3
Key to Results		
 = Complied  = Did not comply		

Note(s):

1. The measurement was performed to assist in the calculation of the level of average output power, power spectral density and emissions as the EUT employs pulsed operation.
2. Frequency stability is better than 20 ppm which ensures that the signal remains in the allocated bands under all operational conditions stated in the user manual.
3. Transmit Power Control was not tested as the maximum EIRP is less than 500 mW (27 dBm).

2.3. Methods and Procedures

Reference:	ANSI C63.10-2013
Title:	American National Standard of Procedures for Compliance Testing of Unlicensed Wireless Devices
Reference:	KDB 789033 D02 General UNII Test Procedures New Rules v01r03 August 22, 2016
Title:	Guidelines for Compliance Testing of Unlicensed National Information Infrastructure (U-NII) Devices – Part 15, Subpart E
Reference:	KDB662911 D01 Multiple Transmitter Output v02r01 October 31, 2013
Title:	Emissions Testing of Transmitter with Multiple Outputs in the Same Band
Reference:	FCC KDB 174176 D01 Line Conducted FAQ v01r01 June 3, 2015
Title:	AC Power-Line Conducted Emissions, Frequently Asked Questions

2.4. Deviations from the Test Specification

For the measurements contained within this test report, there were no deviations from, additions to, or exclusions from the test specifications identified above.

3. Equipment Under Test (EUT)

3.1. Identification of Equipment Under Test (EUT)

Brand Name:	WUS-AC08V
Model Name or Number:	WUS-AC08V
Test Sample MAC address:	542AA22F8F19 (<i>Conducted sample</i>)
Hardware Version:	A1G
Software Version:	4.2.3.5
FCC ID:	TTUWUSAC08V

3.1.1 Host Product Details

Brand Name:	BeoVision Avant 55 NG
Model Name or Number:	BeoVision Avant 55 NG
Test Sample Serial Number:	92777 (<i>Radiated sample</i>)
Hardware Version:	8009004
Software Version:	7.77

Description:	AC power cable
Brand Name:	Not marked or stated
Model Name or Number:	Not marked or stated
Serial Number:	Not marked or stated

3.2. Description of EUT

The equipment under test was a *Bluetooth Basic Rate + EDR, Bluetooth Low Energy*, IEEE 802.11a,b,g,n,ac WLAN module operating in the 2.4 GHz and 5 GHz bands, which was incorporated into a 55" Television. The EUT has two external antenna ports with two transmit chains and MIMO is supported. For 802.11a/g/n/ac operation the device uses two by two MIMO transmitters. Depending on the 802.11 data rate, the device transmits 1 or 2 spatial stream. The device uses spatial multiplexing and from an RF point of view the streams are correlated.

3.3. Modifications Incorporated in the EUT

No modifications were applied to the EUT during testing.

3.4. Additional Information Related to Testing

Technology Tested:	WLAN (IEEE 802.11a,n,ac) / U-NII		
Type of Unit:	Transceiver		
Modulation:	BPSK, QPSK, 16QAM, 64QAM & 256QAM		
Data rates:	802.11a	6, 9, 12, 18, 24, 36, 48 & 54 Mbps	
	802.11n HT20 (SISO)	MCS0 to MCS7	
	802.11n HT20 (MIMO)	MCS0 to MCS15 (CDD MCS0 to MCS7)	
	802.11n HT40 (SISO)	MCS0 to MCS7	
	802.11n HT40 (MIMO)	MCS0 to MCS15 (CDD MCS0 to MCS7)	
	802.11ac VHT20	MCS0 to MCS8	
	802.11ac VHT40	MCS0 to MCS9	
	802.11ac VHT80	MCS0 to MCS9	
Power Supply Requirement(s):	Nominal	Module	3.3 VDC
		TV	120/240 VAC 60 Hz
Antenna Gains:	Frequency (GHz)	Antenna 1	Antenna 2
	5.15 to 5.25	6.1 dBi	6.3 dBi
	5.725 to 5.85	4.7 dBi	5.9 dBi
Maximum Conducted Output Power:	Channel Bandwidth (MHz)	U-NII-1	U-NII-3
	20	14.0 dBm	12.0 dBm
	40	12.9 dBm	10.4 dBm
	80	12.9 dBm	10.0 dBm
Transmit Frequency Band:	5150 MHz to 5250 MHz		
Channel Spacing:	20 MHz		
Transmit Channels Tested:	Channel ID	Channel Number	Channel Frequency (MHz)
	Bottom	36	5180
	Middle	40	5200
	Top	48	5240
Channel Spacing:	40 MHz		
Transmit Channels Tested:	Channel ID	Channel Number	Channel Frequency (MHz)
	Bottom	38	5190
	Top	46	5230

Additional Information Related to Testing (continued)

Channel Spacing:	80 MHz		
Transmit Channel Tested:	Channel ID	Channel Number	Channel Frequency (MHz)
	Single	42	5210
Transmit Frequency Band:	5725 MHz to 5850 MHz		
Channel Spacing:	20 MHz		
Transmit Channels Tested:	Channel ID	Channel Number	Channel Frequency (MHz)
	Bottom	149	5745
	Middle	157	5785
	Top	165	5825
Channel Spacing:	40 MHz		
Transmit Channels Tested:	Channel ID	Channel Number	Channel Frequency (MHz)
	Bottom	151	5755
	Top	159	5795
Channel Spacing:	80 MHz		
Transmit Channel Tested:	Channel ID	Channel Number	Channel Frequency (MHz)
	Single	155	5775

3.5. Support Equipment

The following support equipment was used to exercise the EUT during testing:

Description:	Laptop PC
Brand Name:	Lenovo
Model Name or Number:	E555
Serial Number:	Not marked or stated

Description:	USB Interface Adaptor
Brand Name:	Not marked or stated
Model Name or Number:	Not marked or stated
Serial Number:	Not marked or stated

Description:	USB-A to USB-B cable. Quantity 1. Length 1.8 metres
Brand Name:	Not marked or stated
Model Name or Number:	Not marked or stated
Serial Number:	Not marked or stated

Support Equipment (continued)

Description:	Remote control for 55" Television
Brand Name:	Bang & Olufsen a/s
Model Name or Number:	BeoRemote One T30
Serial Number:	25143484

Description:	External BTLE box to turn on the TV
Brand Name:	Alpha Network
Model Name or Number:	WUS-AC08V
Serial Number:	H11145216

Description:	HDMI cable. Quantity 4. Length 2 metres
Brand Name:	Not marked or stated
Model Name or Number:	Not marked or stated
Serial Number:	Not marked or stated

Description:	Now TV set top box
Brand Name:	Sky
Model Name or Number:	2400SK
Serial Number:	1MM4DE006281

Description:	Now TV set top box
Brand Name:	Sky
Model Name or Number:	2400SK
Serial Number:	1MM4D8006255

Description:	HDMI media player
Brand Name:	SUMVISION
Model Name or Number:	Cyclone Micro
Serial Number:	SUM091104017

Description:	Ethernet cable. Quantity 3. Length 2 metres
Brand Name:	Not marked or stated
Model Name or Number:	Not marked or stated
Serial Number:	Not marked or stated

Support Equipment (continued)

Description:	Ethernet cable. Quantity 3. Length 3 metres
Brand Name:	Not marked or stated
Model Name or Number:	Not marked or stated
Serial Number:	Not marked or stated

Description:	Ethernet cable. Quantity 1. Length 5 metres
Brand Name:	Not marked or stated
Model Name or Number:	Not marked or stated
Serial Number:	Not marked or stated

Description:	Ethernet cable. Quantity 1. Length 10 metres
Brand Name:	Not marked or stated
Model Name or Number:	Not marked or stated
Serial Number:	Not marked or stated

Description:	5 port Ethernet switch
Brand Name:	Netgear
Model Name or Number:	GS605 v3
Serial Number:	1YG194390218E

Description:	5 port Ethernet switch
Brand Name:	Netgear
Model Name or Number:	GS605 v3
Serial Number:	1YG19430021A1

Description:	3.5 mm Male to 2xRCA male audio cable. Quantity 1. Length 2 m
Brand Name:	Not marked or stated
Model Name or Number:	Not marked or stated
Serial Number:	Not marked or stated

Description:	Aerial cable. Quantity 1. Length 2 metres
Brand Name:	Belkin
Model Name or Number:	Not marked or stated
Serial Number:	Not marked or stated

Support Equipment (continued)

Description:	Freeview HD Set Top Box
Brand Name:	Technika
Model Name or Number:	STBHDIS2010
Serial Number:	GRTB58073912047

Description:	USB cable type A male to type A male. Quantity 1. Length 1.5 m
Brand Name:	Not marked or stated
Model Name or Number:	Not marked or stated
Serial Number:	Not marked or stated

Description:	USB Hub
Brand Name:	Belkin
Model Name or Number:	Not marked or stated
Serial Number:	Not marked or stated

Description:	USB extension lead. Quantity 1. Length 2 metres
Brand Name:	Not marked or stated
Model Name or Number:	Not marked or stated
Serial Number:	Not marked or stated

Description:	22" HD Television
Brand Name:	LOGIK
Model Name or Number:	22FE12A
Serial Number:	1309020661

Description:	Freeview HD Set Top Box
Brand Name:	Sagem
Model Name or Number:	251657024
Serial Number:	441901036882

4. Operation and Monitoring of the EUT during Testing

4.1. Operating Modes

The EUT was tested in the following operating mode(s):

- Continuously transmitting with a modulated carrier at maximum power on the bottom, middle and top channels as required using the supported data rates/modulation types.

4.2. Configuration and Peripherals

The EUT was tested in the following configuration(s):

- Controlled using *MT7662U_QA_tool_V1.0.3.0* test application supplied by the customer on a UL laptop PC. The application was used to enable a continuous transmission mode and to select the test channels, data rates and modulation schemes as required.
- All supported modes and channel widths were initially investigated on one channel. The modes that produced the highest power for all bands were:
 - Highest power
 - 802.11a SISO – BPSK / 6 Mbps
 - 802.11a CDD – BPSK / 6 Mbps
 - 802.11n HT20 SISO – 16QAM / 26 Mbps / MCS3
 - 802.11n HT40 SISO – 16QAM / 54 Mbps / MCS3
 - 802.11n HT20 MIMO – QPSK / 13 Mbps / MCS1
 - 802.11n HT40 MIMO – 16QAM / 54 Mbps / MCS3
 - 802.11ac VHT80 SISO – QPSK / 87.8 Mbps / MCS2
 - 802.11ac VHT80 MIMO – 16QAM / 117 Mbps / MCS3
 - Highest power spectral density
 - 802.11a – BPSK / 6 Mbps
 - 802.11a CDD – BPSK / 6 Mbps
 - 802.11n HT20 SISO – 64QAM / 52 Mbps / MCS5
 - 802.11n HT40 SISO – QPSK / 40.5 Mbps / MCS2
 - 802.11n HT20 MIMO – QPSK / 13 Mbps / MCS1
 - 802.11n HT40 MIMO – BPSK / 13.5 Mbps / MCS0
 - 802.11ac VHT80 SISO – QPSK / 87.8 Mbps / MCS2
 - 802.11ac VHT80 MIMO – 16QAM / 117 Mbps / MCS3

Configuration and Peripherals (continued)

- All supported modes and channel widths were initially investigated on one channel. The modes that produced the widest and narrowest bandwidth for all bands were:
 - Widest bandwidth
 - 802.11a SISO – BPSK / 6 Mbps
 - 802.11a CDD – BPSK / 6 Mbps
 - 802.11n HT20 SISO – BPSK / 6.5 Mbps / MCS0
 - 802.11n HT40 SISO – BPSK / 13.5 Mbps / MCS0
 - 802.11n HT20 MIMO – BPSK / 6.5 Mbps / MCS0
 - 802.11n HT40 MIMO – BPSK / 13.5 Mbps / MCS0
 - 802.11ac VHT80 SISO – QPSK / 87.8 Mbps / MCS2
 - 802.11ac VHT80 MIMO – BPSK / 29.3 Mbps / MCS0
 - Narrowest bandwidth
 - 802.11a – BPSK / 6 Mbps
 - 802.11a CDD – BPSK / 6 Mbps
 - 802.11n HT20 SISO – BPSK / 6.5 Mbps / MCS0
 - 802.11n HT40 SISO – BPSK / 13.5 Mbps / MCS0
 - 802.11n HT20 MIMO – BPSK / 6.5 Mbps / MCS0
 - 802.11n HT40 MIMO – BPSK / 13.5 Mbps / MCS0
 - 802.11ac VHT80 SISO – BPSK / 29.3 Mbps / MCS0
 - 802.11ac VHT80 MIMO – BPSK / 29.3 Mbps / MCS0

Pre-scan results for all modes are archived on the UL VS LTD IT server and available for inspection if required.

- For 802.11n HT modes, *HT MixMode* & *HT GreenField* data formats were selectable. Both formats were initially compared on a range of modulation types and bandwidths, and found to give identical results. For all tests requiring HT modes, *HT MixMode* was therefore selected.
- For all conducted measurements the EUT, being the module, was connected to a DC power supply and powered by 3.3 VDC. The module consisted of a pcb fitted with an 8-pin in-line connector. The customer supplied a bespoke USB adaptor assembly that allowed a USB-B socket to interface to the 8-pin connector. Additionally the USB adaptor was fitted with two flying leads that connected to an external laboratory power supply to provide DC voltage to the EUT.
- For all radiated measurements the EUT, being the TV, was connected to 120 or 240 VAC 60 Hz depending on the test case. The customer had fitted a USB cable to the module that was inside the TV. This was used to place the TV into test mode as required.
- The EUT has two separate antennas which correspond to two separate antenna ports. DAC 0 and DAC 1 correspond to antenna 1 and antenna 2 respectively.
- For 802.11b the EUT transmits only from antenna 1, therefore conducted measurements were performed on DAC0 only.
- For 802.11n and 802.11ac the EUT can transmit from both antennas, therefore conducted measurements were performed on both ports.
- The customer declared the power settings which are stated in section 4.3 of this test report

Configuration and Peripherals (continued)

- RF cables and attenuators connecting the test equipment to the EUT were calibrated before use and the calibration data incorporated into the conducted measurement results
- Radiated emissions were performed with the EUT transmitting with a data rate of 802.11a / 6 Mbps on Antenna 1 as it produced the worst conducted output power and highest spectral density level and was therefore deemed worst case.
- The module did not have an internal integral antenna but was fitted with a U.FL antenna connector. All radiated measurements were performed with the module placed in its end host device, the 55" television.
- Radiated measurements: In order to operate the EUT the TV needed to be enabled. This was done by turning on the TV and pairing it with T30 remote control with the external BTLE box which was connected to the TV. The external BTLE box has a 0.83 metre cable with a USB type A male connector. Once the TV was enabled, the EUT could be controlled using the MT7662U application.
- Once the TV was turned on and the EUT was in transmit mode the T30 remote control and external BTLE box were removed from the chamber.
- For all radiated tests the support equipment was used to terminate all active ports.
- The sample with MAC address 542AA22F8D19 was used for 26 dB emission bandwidth, minimum 6 dB bandwidth, duty cycle, maximum conducted output power and peak power spectral density tests.
- The sample with serial number 92777 was used for all other measurements. The EUT was fitted with temporary antenna connectors, the installation of which permanently inhibited the integral antennas. The customer requested radiated spurious emissions tests to be performed as part of the end host equipment testing.

4.3. Power Settings Used During Testing

The manufacturer's declared power settings stated in the table below were used for both SISO and MIMO measurements:

Mode	Power Setting					
	Frequency Band 5.15 to 5.25 GHz			Frequency Band 5.725 to 5.85 GHz		
	Bottom Channel	Middle Channel	Top Channel	Bottom Channel	Middle Channel	Top Channel
802.11a SISO / 6 Mbps	16	16	16	16	16	16
802.11a CDD / 6 Mbps	10	10	10	10	10	10
802.11n HT20 / SISO / MCS0	18	18	18	18	18	18
802.11n HT20 / SISO / MCS3	18	18	18	18	18	18
802.11n HT20 / SISO / MCS5	1A	1A	1A	1A	1A	1A
802.11n HT40 / SISO / MCS0	18	N/A	18	18	N/A	18
802.11n HT40 / SISO / MCS2	18	N/A	18	18	N/A	18
802.11n HT40 / SISO / MCS3	18	N/A	18	18	N/A	18
802.11n HT20 / MIMO / MCS0	12	12	12	12	12	12
802.11n HT20 / MIMO / MCS1	12	12	12	12	12	12
802.11n HT40 / MIMO / MCS0	12	N/A	12	12	N/A	12
802.11n HT40 / MIMO / MCS3	12	N/A	12	12	N/A	12
802.11ac VHT80 / SISO / MCS0	N/A	1A	N/A	N/A	1A	N/A
802.11ac VHT80 / SISO / MCS2	N/A	1A	N/A	N/A	1A	N/A
802.11ac VHT80 / MIMO / MCS0	N/A	14.0	N/A	N/A	14.0	N/A
802.11ac VHT80 / MIMO / MCS3	N/A	14.0	N/A	N/A	14.0	N/A

5. Measurements, Examinations and Derived Results

5.1. General Comments

Measurement uncertainties are evaluated in accordance with current best practice. Our reported expanded uncertainties are based on standard uncertainties, which are multiplied by an appropriate coverage factor to provide a statistical confidence level of approximately 95%. Please refer to *Section 6 Measurement Uncertainty* for details.

In accordance with UKAS requirements all the measurement equipment is on a calibration schedule. All equipment was within the calibration period on the date of testing.

5.2. Test Results

5.2.1. Transmitter AC Conducted Spurious Emissions

Test Summary:

Test Engineer:	Andrew Edwards	Test Date:	04 April 2016
Test Sample Serial Number:	92777		

FCC Reference:	Part 15.207
Test Method Used:	ANSI C63.10 Section 6.2 / FCC KDB 174176 and notes below.

Environmental Conditions:

Temperature (°C):	22
Relative Humidity (%):	40

Note(s):

1. The EUT was connected to a 120 VAC 60 Hz single phase supply via a LISN.
2. In accordance with FCC KDB 174176 Q4, tests were also performed with a 240 VAC 60 Hz single phase supply as this was within the voltage range of the EUT's power supply.
3. A pulse limiter was fitted between the LISN and the test receiver.
4. Pre-scans were performed and markers placed on the highest live and neutral measured levels. Final measurements were performed on the marker frequencies and the results entered into the tables below.

Transmitter AC Conducted Spurious Emissions (continued)

Test setup:

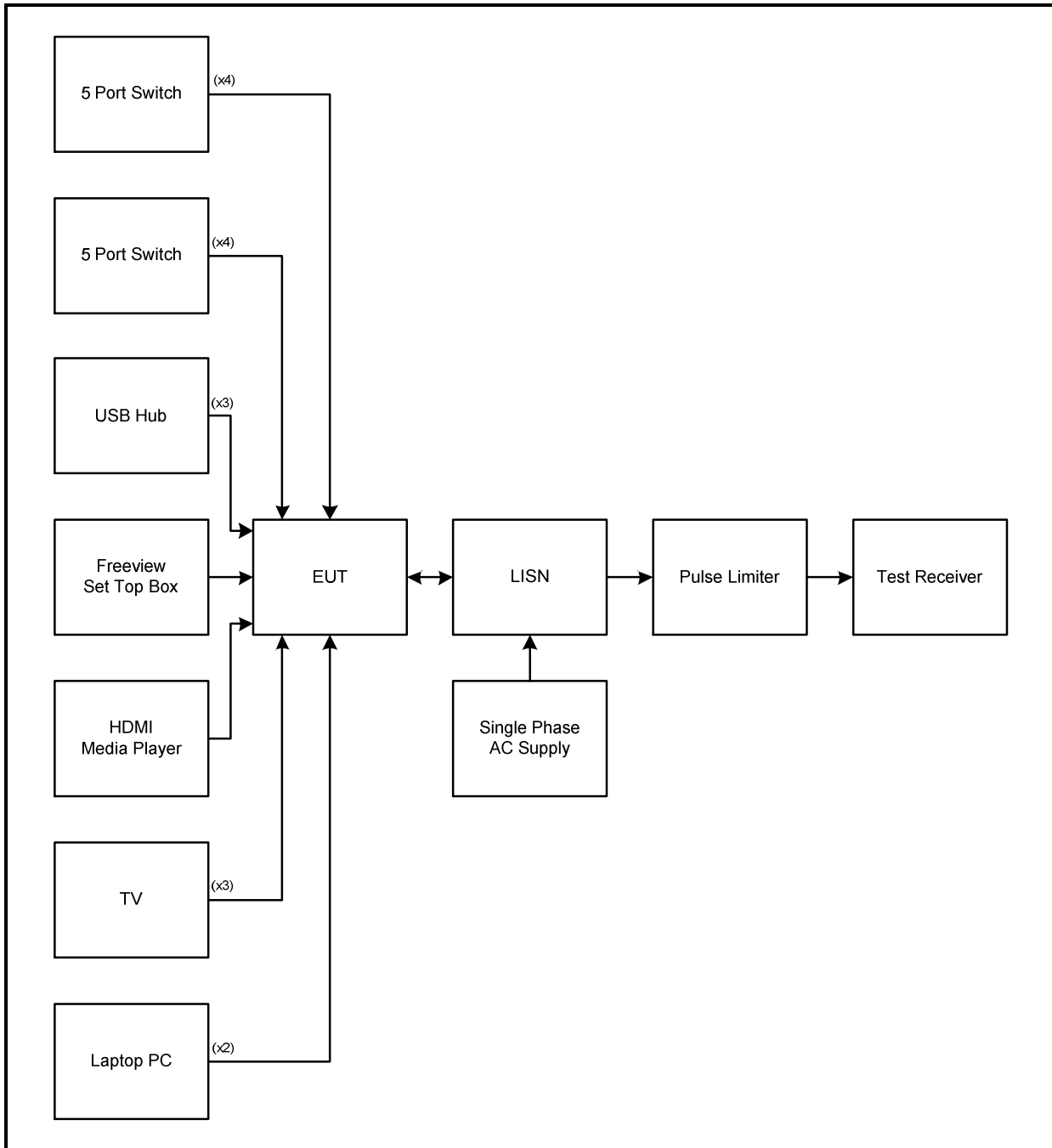

Transmitter AC Conducted Spurious Emissions (continued)**Results: Live / Quasi Peak / 120 VAC 60 Hz**

Frequency (MHz)	Line	Level (dB μ V)	Limit (dB μ V)	Margin (dB)	Result
1.199	Live	37.7	56.0	18.3	Complied
1.901	Live	37.6	56.0	18.4	Complied
2.045	Live	38.3	56.0	17.7	Complied
3.732	Live	37.5	56.0	18.5	Complied
7.251	Live	42.7	60.0	17.3	Complied
7.391	Live	42.6	60.0	17.4	Complied

Results: Live / Average / 120 VAC 60 Hz

Frequency (MHz)	Line	Level (dB μ V)	Limit (dB μ V)	Margin (dB)	Result
0.213	Live	43.4	53.1	9.7	Complied
0.915	Live	42.3	46.0	3.7	Complied
1.199	Live	36.3	46.0	9.7	Complied
1.338	Live	37.0	46.0	9.0	Complied
1.761	Live	36.5	46.0	9.5	Complied
1.901	Live	36.6	46.0	9.4	Complied

Results: Neutral / Quasi Peak / 120 VAC 60 Hz

Frequency (MHz)	Line	Level (dB μ V)	Limit (dB μ V)	Margin (dB)	Result
0.258	Neutral	44.8	61.5	16.7	Complied
0.776	Neutral	39.5	56.0	16.5	Complied
0.915	Neutral	39.2	56.0	16.8	Complied
1.338	Neutral	38.8	56.0	17.2	Complied
2.045	Neutral	39.2	56.0	16.8	Complied
5.982	Neutral	43.4	60.0	16.6	Complied

Results: Neutral / Average / 120 VAC 60 Hz

Frequency (MHz)	Line	Level (dB μ V)	Limit (dB μ V)	Margin (dB)	Result
0.353	Neutral	41.5	48.9	7.4	Complied
0.492	Neutral	40.2	46.1	5.9	Complied
0.776	Neutral	38.9	46.0	7.1	Complied
0.915	Neutral	39.0	46.0	7.0	Complied
1.055	Neutral	38.2	46.0	7.8	Complied
1.338	Neutral	38.3	46.0	7.7	Complied

Transmitter AC Conducted Spurious Emissions (continued)

Results: 120 VAC 60 Hz

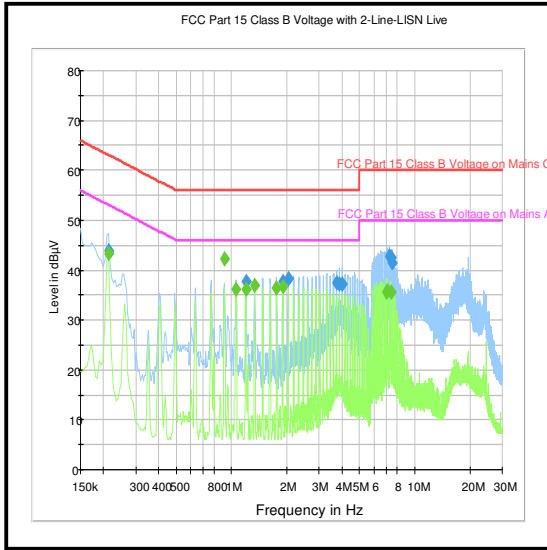

Live

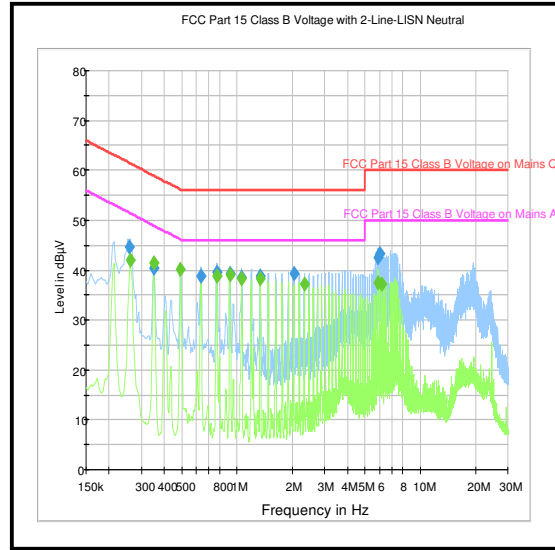

Neutral

Note: These plots are pre-scans and for indication purposes only. For final measurements, see accompanying tables.

Transmitter AC Conducted Spurious Emissions (continued)**Results: Live / Quasi Peak / 240 VAC 60 Hz**

Frequency (MHz)	Line	Level (dB μ V)	Limit (dB μ V)	Margin (dB)	Result
0.371	Live	45.6	58.5	12.9	Complied
0.632	Live	40.3	56.0	15.7	Complied
0.776	Live	41.0	56.0	15.0	Complied
0.915	Live	41.1	56.0	14.9	Complied
1.055	Live	40.4	56.0	15.6	Complied
1.338	Live	40.3	56.0	15.7	Complied

Results: Live / Average / 240 VAC 60 Hz

Frequency (MHz)	Line	Level (dB μ V)	Limit (dB μ V)	Margin (dB)	Result
0.371	Live	42.2	48.5	6.3	Complied
0.915	Live	40.8	46.0	5.2	Complied
1.055	Live	39.5	46.0	6.5	Complied
1.338	Live	38.9	46.0	7.1	Complied
1.478	Live	38.8	46.0	7.2	Complied
1.901	Live	37.8	46.0	8.2	Complied

Results: Neutral / Quasi Peak / 240 VAC 60 Hz

Frequency (MHz)	Line	Level (dB μ V)	Limit (dB μ V)	Margin (dB)	Result
0.263	Neutral	46.5	61.4	14.9	Complied
0.492	Neutral	43.5	56.1	12.6	Complied
0.632	Neutral	42.3	56.0	13.7	Complied
0.776	Neutral	42.6	56.0	13.4	Complied
1.055	Neutral	41.3	56.0	14.7	Complied
1.199	Neutral	41.0	56.0	15.0	Complied

Results: Neutral / Average / 240 VAC 60 Hz

Frequency (MHz)	Line	Level (dB μ V)	Limit (dB μ V)	Margin (dB)	Result
0.353	Neutral	42.6	48.9	6.3	Complied
0.492	Neutral	41.7	46.1	4.4	Complied
0.776	Neutral	40.9	46.0	5.1	Complied
0.915	Neutral	40.9	46.0	5.1	Complied
1.055	Neutral	39.9	46.0	6.1	Complied
1.338	Neutral	39.6	46.0	6.4	Complied

Transmitter AC Conducted Spurious Emissions (continued)

Results: 240 VAC 60 Hz

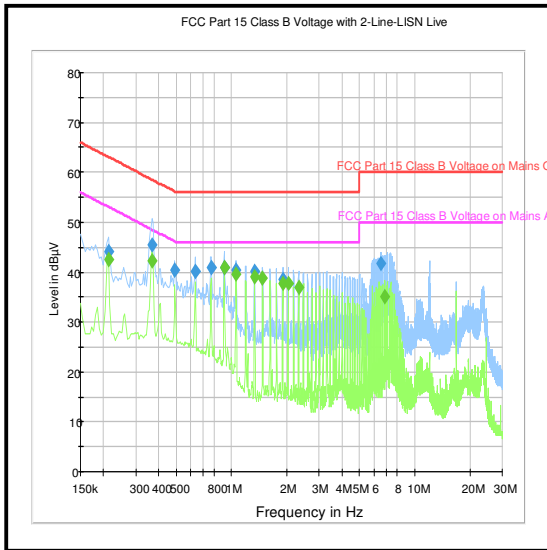

Live

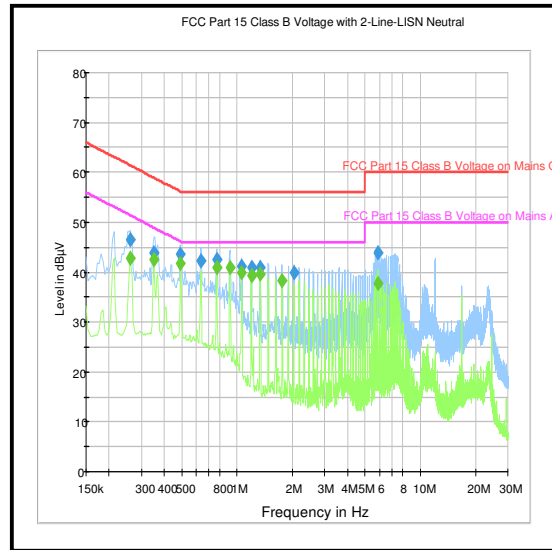

Neutral

Note: These plots are pre-scans and for indication purposes only. For final measurements, see accompanying tables.

Test Equipment Used:

Asset No.	Instrument	Manufacturer	Type No.	Serial No.	Date Calibration Due	Cal. Interval (Months)
M1624	Thermohygrometer	JM Handlungspunkt	30.5015.10	Not stated	11 Jan 2017	12
M1263	Test Receiver	Rohde & Schwarz	ESIB7	100265	16 Oct 2016	12
A067	LISN	Rohde & Schwarz	ESH3-Z5	890603/002	27 Aug 2016	12
A1830	Pulse Limiter	Rohde & Schwarz	ESH3-Z2	100668	08 Mar 2017	12
M1251	Digital Multimeter	Fluke	175	89170179	26 May 2016	12
S0539	Variable AC Power Supply	Kikusui	PCR 1000L	13010170	Calibrated before use	-

5.2.2. Transmitter 26 dB Emission Bandwidth**Test Summary:**

Test Engineer:	Georgios Vrezas	Test Dates:	08 June 2016 to 10 June 2016
Test Sample MAC address:	542AA22F8F19		

FCC Reference:	Part 15.403(i)
Test Method Used:	KDB 789033 D02 Section II.C.1.

Environmental Conditions:

Temperature (°C):	23 to 25
Relative Humidity (%):	36 to 53

Note(s):

1. All configurations supported by the EUT were investigated on the one channel in accordance with KDB 789033 Section II.C.1. Emission Bandwidth (EBW) test procedure. The data rates that produced the widest bandwidth and therefore deemed worst case were:
 - 802.11a SISO – BPSK / 6 Mbps
 - 802.11a CDD – BPSK / 6 Mbps
 - 802.11n HT20 SISO – BPSK / MCS0
 - 802.11n HT20 MIMO – BPSK / MCS0
 - 802.11n HT40 SISO – BPSK / MCS0
 - 802.11n HT40 MIMO – BPSK / MCS0
 - 802.11ac VHT80 SISO - QPSK / MCS2
 - 802.11ac VHT80 MIMO – BPSK / MCS0
2. Final measurements were performed in each supported operating band using the above configurations on the bottom, middle and top or single channels.
3. For 20 MHz channel bandwidths, the signal analyser resolution bandwidth was set to 200 kHz and video bandwidth 1 MHz. A peak detector was used, sweep time was set to auto and the trace mode was Max Hold. The span was set to 30 MHz.
4. For 40 MHz channel bandwidths, the signal analyser resolution bandwidth was set to 500 kHz and video bandwidth 2 MHz. A peak detector was used, sweep time was set to auto and the trace mode was Max Hold. The span was set to 60 MHz.
5. For 80 MHz channel bandwidths, the signal analyser resolution bandwidth was set to 1 MHz and video bandwidth 3 MHz. A peak detector was used, sweep time was set to auto and the trace mode was Max Hold. The span was set to 160 MHz.
6. Plots for all data rates on both ports are archived on the UL VS LTD IT server and available for inspection upon request.
7. The signal analyser was connected to the RF port on the EUT using suitable attenuation and RF cable.

Transmitter 26 dB Emission Bandwidth (continued)**Note(s):**

8. For the power measurements in this report, the highest power output level was recorded when the EUT was configured as:
- 802.11n HT20 SISO – 16QAM / MCS3
 - 802.11n HT40 SISO – 16QAM / MCS3
 - 802.11n HT20 MIMO – QPSK / MCS1
 - 802.11n HT40 MIMO – 16QAM MCS3
 - 802.11ac VHT80 MIMO – 16QAM / MCS3

Emission bandwidth plots for these configurations have been included as 'Reference plots' at the end of this section and the results used for calculations in Section 5.2.4 of this test report.

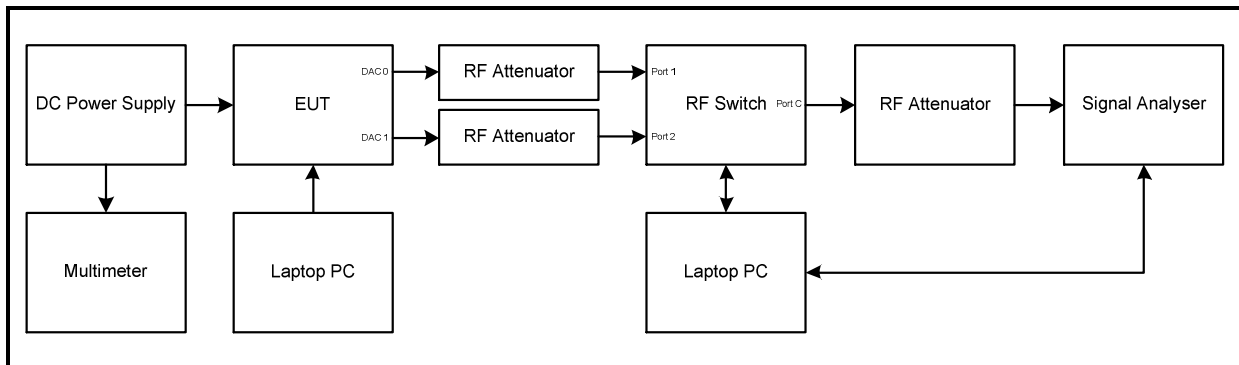
Test setup:

Transmitter 26 dB Emission Bandwidth (continued)

Results: 802.11a / 20 MHz / SISO / 5.15-5.25 GHz band / DAC 0

Channel	Frequency (MHz)	Modulation scheme	Data Rate (Mbps)	26 dB Emission Bandwidth (MHz)
Bottom	5180	BPSK	6	20.101
Middle	5200	BPSK	6	20.405
Top	5240	BPSK	6	20.100

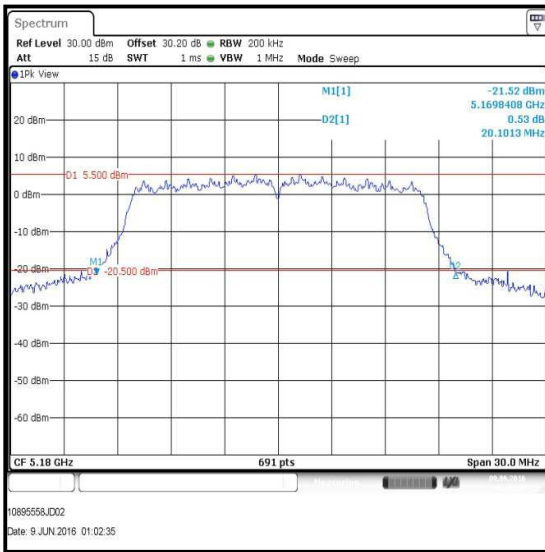

Bottom Channel

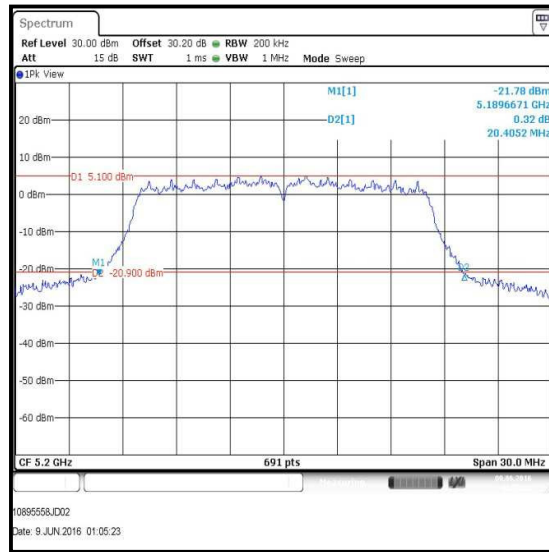

Middle Channel



Top Channel

Transmitter 26 dB Emission Bandwidth (continued)

Results: 802.11a / 20 MHz / CDD / 5.15-5.25 GHz band / DAC 0

Channel	Frequency (MHz)	Modulation scheme	MCS Index	26 dB Emission Bandwidth (MHz)
Bottom	5180	BPSK	6	19.797
Middle	5200	BPSK	6	19.884
Top	5240	BPSK	6	20.145



Bottom Channel

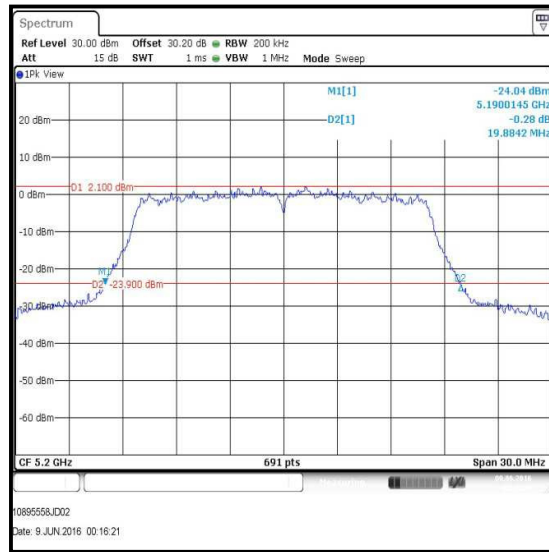

Middle Channel

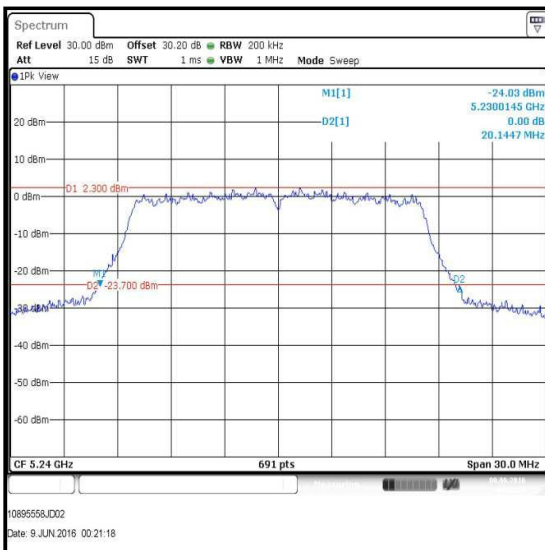

Top Channel

Transmitter 26 dB Emission Bandwidth (continued)

Results: 802.11a / 20 MHz / CDD / 5.15-5.25 GHz band / DAC 1

Channel	Frequency (MHz)	Modulation scheme	Data Rate (Mbps)	26 dB Emission Bandwidth (MHz)
Bottom	5180	BPSK	6	19.797
Middle	5200	BPSK	6	20.015
Top	5240	BPSK	6	19.841



Bottom Channel

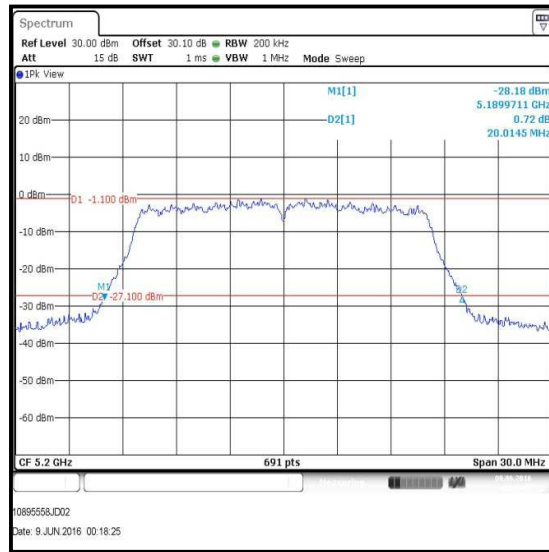

Middle Channel



Top Channel

Transmitter 26 dB Emission Bandwidth (continued)

Results: 802.11n / 20 MHz / SISO / 5.15-5.25 GHz band / DAC 0

Channel	Frequency (MHz)	Modulation scheme	MCS Index	26 dB Emission Bandwidth (MHz)
Bottom	5180	BPSK	0	20.362
Middle	5200	BPSK	0	20.709
Top	5240	BPSK	0	20.405



Bottom Channel

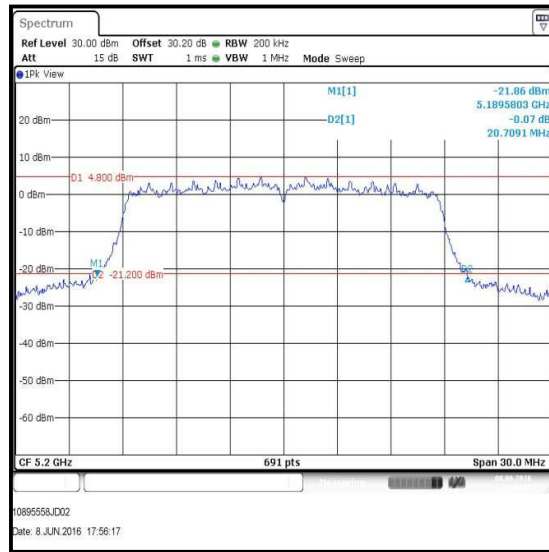

Middle Channel

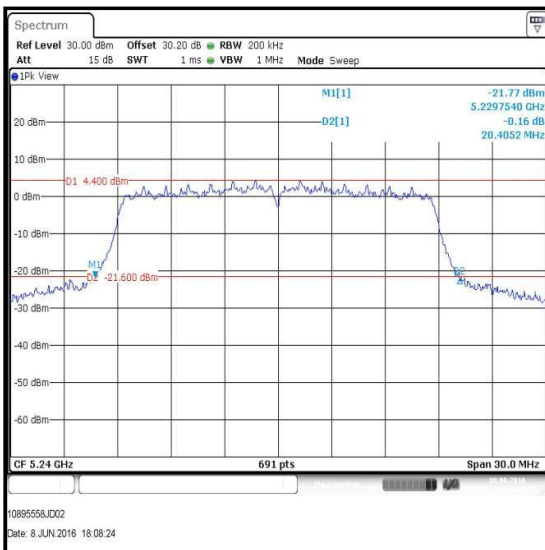

Top Channel

Transmitter 26 dB Emission Bandwidth (continued)

Results: 802.11n / 20 MHz / MIMO / 5.15-5.25 GHz band / DAC 0

Channel	Frequency (MHz)	Modulation scheme	MCS Index	26 dB Emission Bandwidth (MHz)
Bottom	5180	BPSK	0	20.318
Middle	5200	BPSK	0	20.405
Top	5240	BPSK	0	20.232

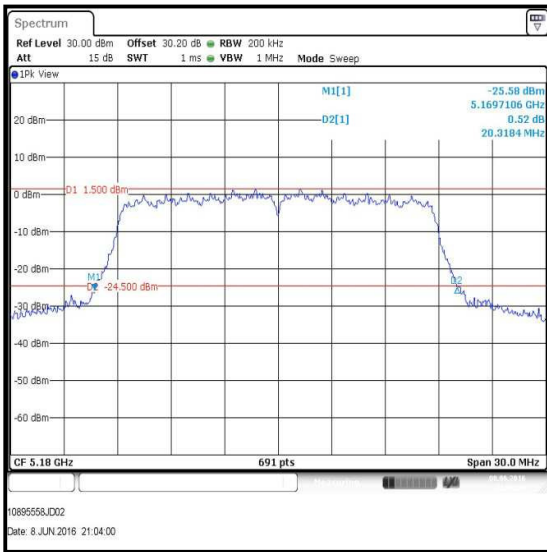

Bottom Channel



Middle Channel

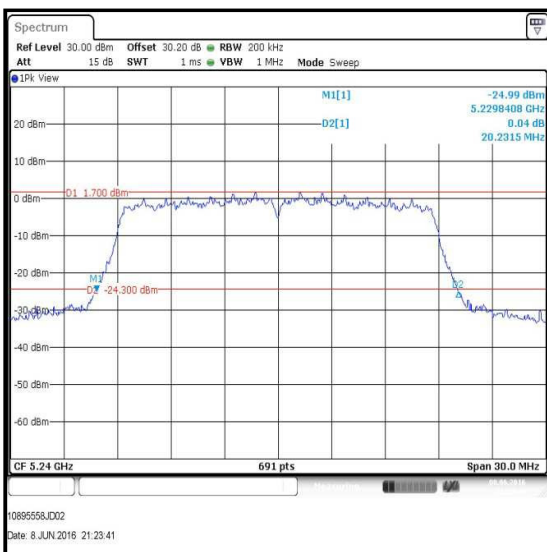

Top Channel

Transmitter 26 dB Emission Bandwidth (continued)

Results: 802.11n / 20 MHz / MIMO / 5.15-5.25 GHz band / DAC 1

Channel	Frequency (MHz)	Modulation scheme	MCS Index	26 dB Emission Bandwidth (MHz)
Bottom	5180	BPSK	0	20.318
Middle	5200	BPSK	0	20.232
Top	5240	BPSK	0	20.405

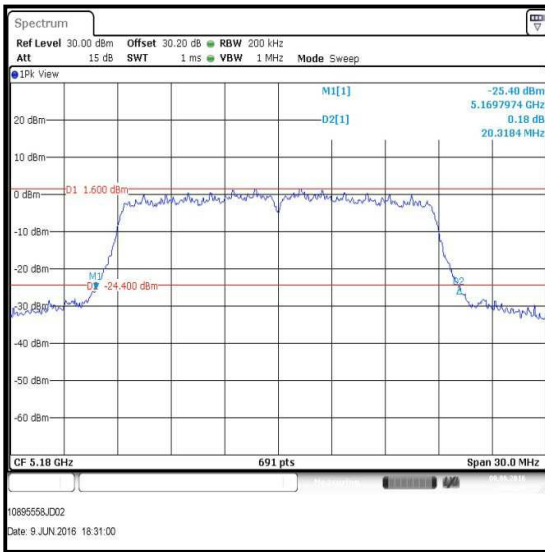

Bottom Channel

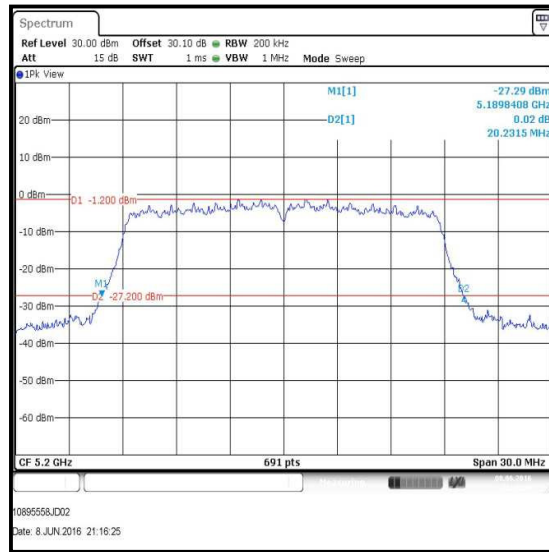

Middle Channel

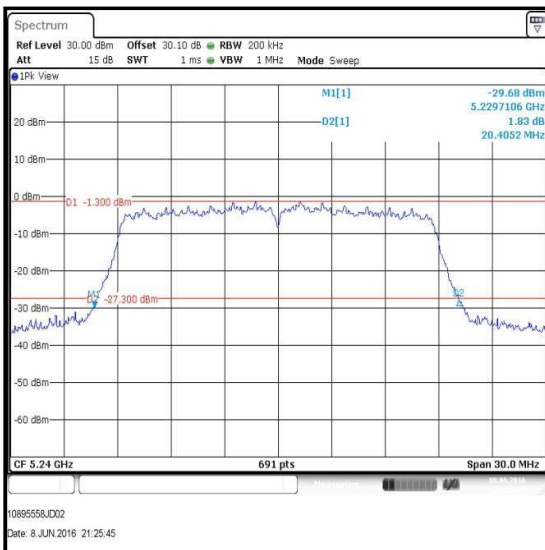

Top Channel

Transmitter 26 dB Emission Bandwidth (continued)

Results: 802.11n / 40 MHz / SISO / 5.15-5.25 GHz band / DAC 0

Channel	Frequency (MHz)	Modulation scheme	MCS Index	26 dB Emission Bandwidth (MHz)
Bottom	5190	BPSK	0	41.766
Top	5230	BPSK	0	42.547

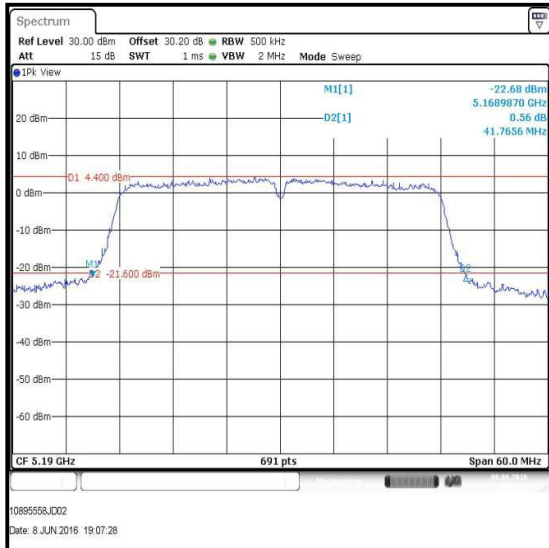

Bottom Channel



Top Channel

Transmitter 26 dB Emission Bandwidth (continued)

Results: 802.11n / 40 MHz / MIMO / 5.15-5.25 GHz band / DAC 0

Channel	Frequency (MHz)	Modulation scheme	MCS Index	26 dB Emission Bandwidth (MHz)
Bottom	5190	BPSK	0	41.592
Top	5230	BPSK	0	41.939

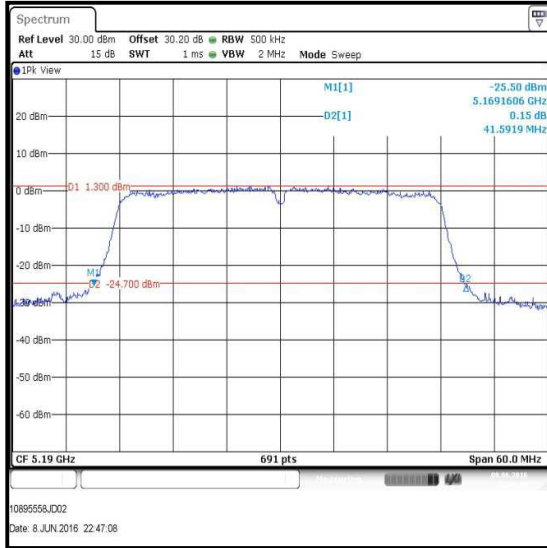

Bottom Channel

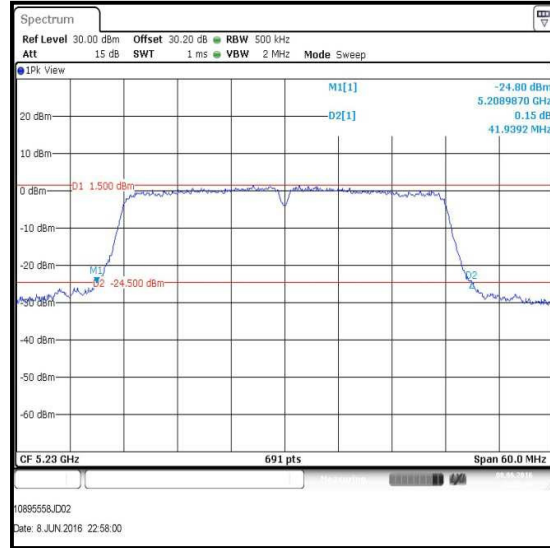

Top Channel

Transmitter 26 dB Emission Bandwidth (continued)

Results: 802.11n / 40 MHz / MIMO / 5.15-5.25 GHz band / DAC 1

Channel	Frequency (MHz)	Modulation scheme	MCS Index	26 dB Emission Bandwidth (MHz)
Bottom	5190	BPSK	0	41.245
Top	5230	BPSK	0	42.113

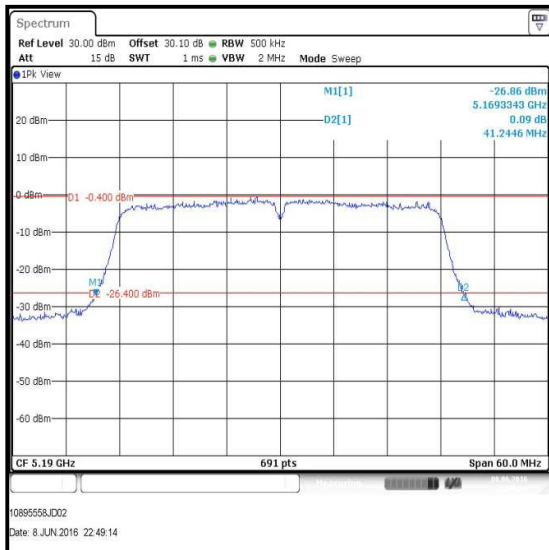

Bottom Channel

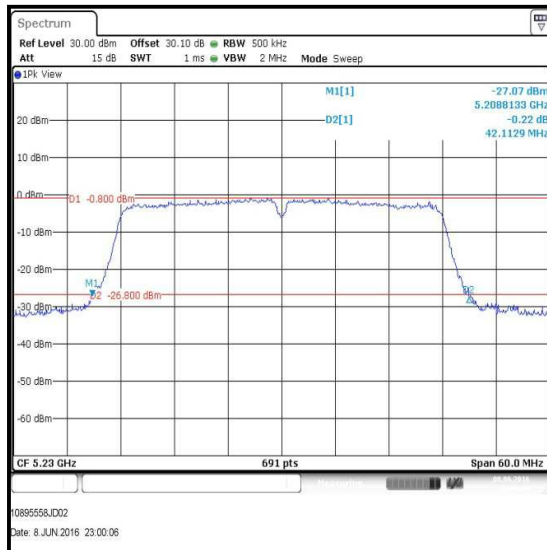

Top Channel

Transmitter 26 dB Emission Bandwidth (continued)

Results: 802.11ac / 80 MHz / SISO / 5.15-5.25 GHz band / DAC 0

Channel	Frequency (MHz)	Modulation scheme	MCS Index	26 dB Emission Bandwidth (MHz)
Single	5210	QPSK	2	81.274

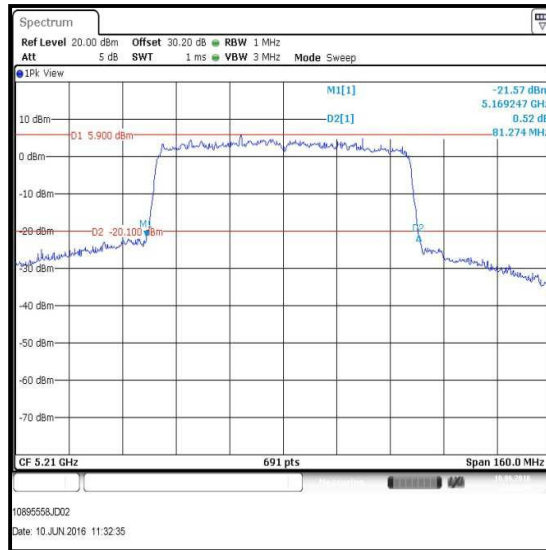

Single Channel

Transmitter 26 dB Emission Bandwidth (continued)

Results: 802.11ac / 80 MHz / MIMO / 5.15-5.25 GHz band / DAC 0

Channel	Frequency (MHz)	Modulation scheme	MCS Index	26 dB Emission Bandwidth (MHz)
Single	5210	BPSK	0	81.737

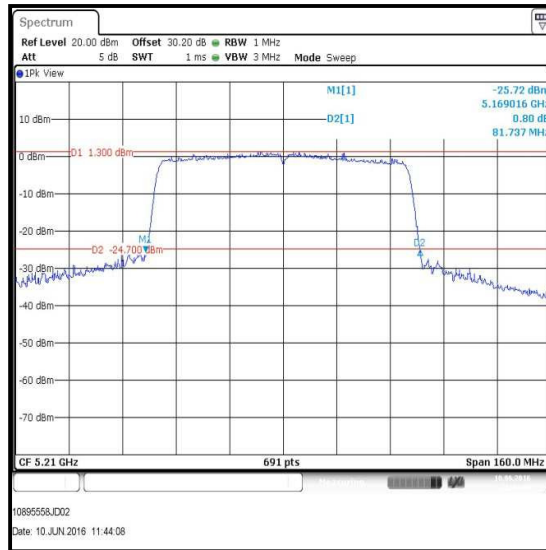

Single Channel

Results: 802.11ac / 80 MHz / MIMO / 5.15-5.25 GHz band / DAC 1

Channel	Frequency (MHz)	Modulation scheme	MCS Index	26 dB Emission Bandwidth (MHz)
Single	5210	BPSK	0	81.505



Single Channel

Transmitter 26 dB Emission Bandwidth (continued)

Results: 802.11a / 20 MHz / SISO / 5.725-5.85 GHz band / DAC 0

Channel	Frequency (MHz)	Modulation scheme	Data Rate (Mbps)	26 dB Emission Bandwidth (MHz)
Bottom	5745	BPSK	6	20.145
Middle	5785	BPSK	6	19.928
Top	5825	BPSK	6	20.232

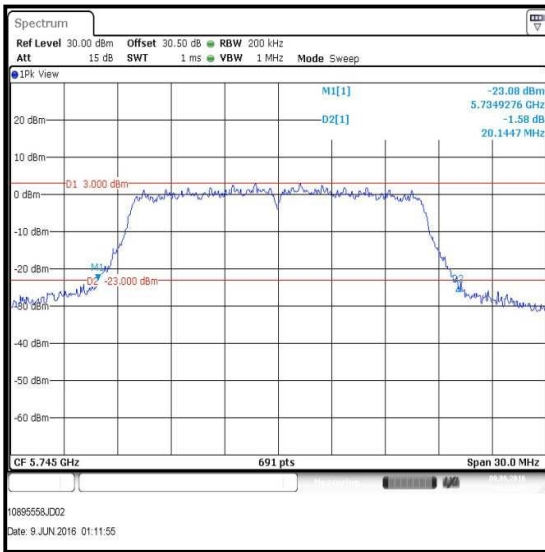

Bottom Channel

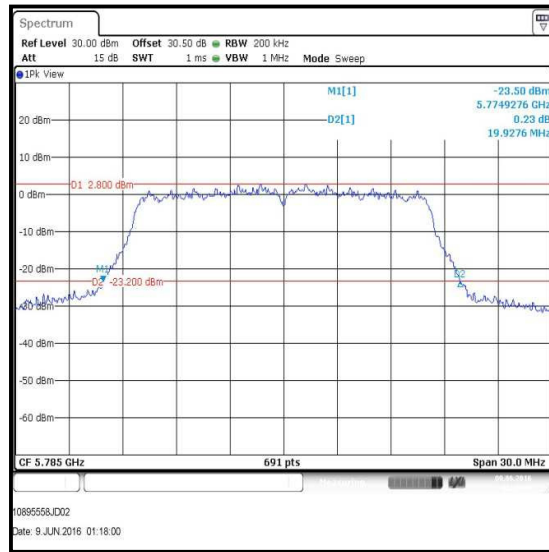

Middle Channel

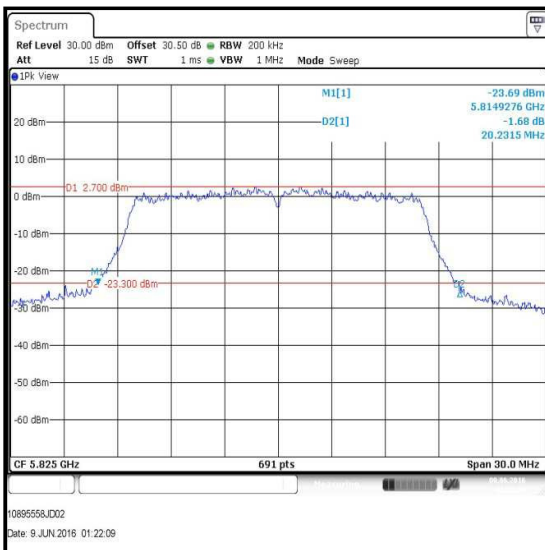

Top Channel

Transmitter 26 dB Emission Bandwidth (continued)

Results: 802.11a / 20 MHz / CDD / 5.725-5.85 GHz band / DAC 0

Channel	Frequency (MHz)	Modulation scheme	Data Rate (Mbps)	26 dB Emission Bandwidth (MHz)
Bottom	5745	BPSK	6	20.058
Middle	5785	BPSK	6	19.971
Top	5825	BPSK	6	19.971



Bottom Channel

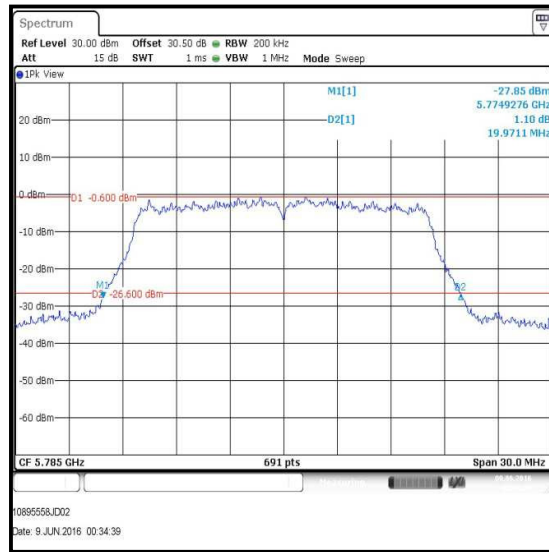

Middle Channel

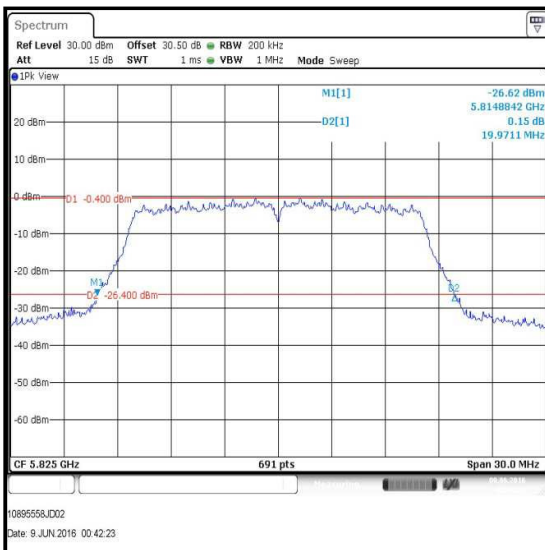

Top Channel

Transmitter 26 dB Emission Bandwidth (continued)

Results: 802.11a / 20 MHz / CDD / 5.725-5.85 GHz band / DAC 1

Channel	Frequency (MHz)	Modulation scheme	Data Rate (Mbps)	26 dB Emission Bandwidth (MHz)
Bottom	5745	BPSK	6	19.971
Middle	5785	BPSK	6	19.754
Top	5825	BPSK	6	19.884

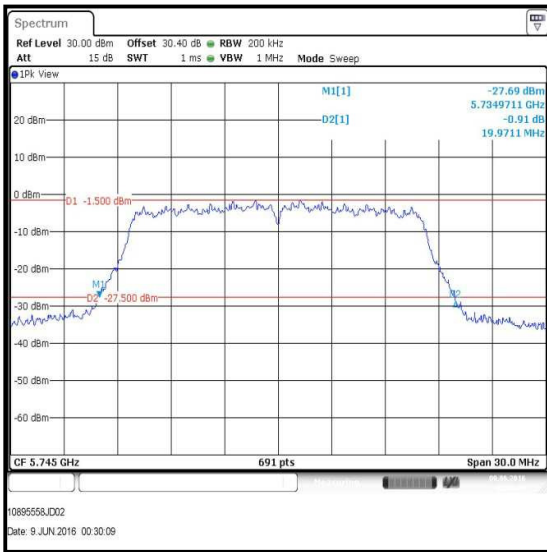

Bottom Channel



Middle Channel

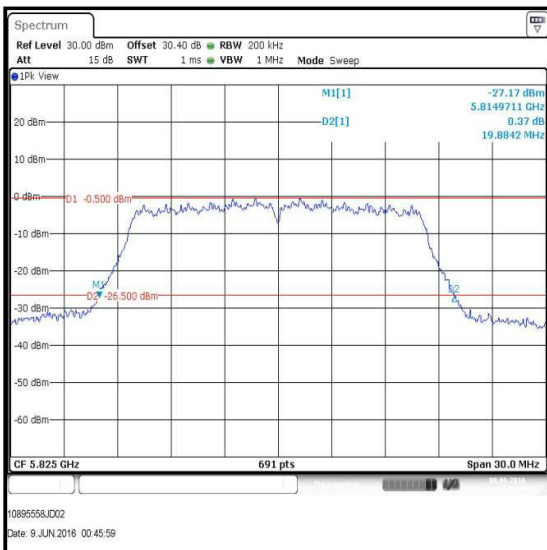

Top Channel

Transmitter 26 dB Emission Bandwidth (continued)

Results: 802.11n / 20 MHz / SISO / 5.725-5.85 GHz band / DAC 0

Channel	Frequency (MHz)	Modulation scheme	MCS Index	26 dB Emission Bandwidth (MHz)
Bottom	5745	BPSK	0	20.275
Middle	5785	BPSK	0	20.492
Top	5825	BPSK	0	20.318

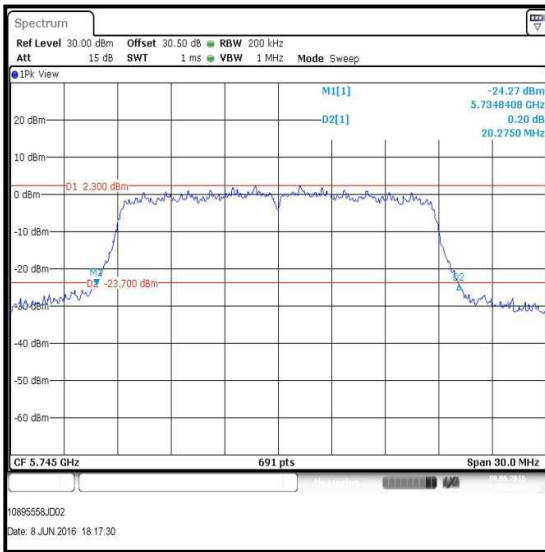

Bottom Channel

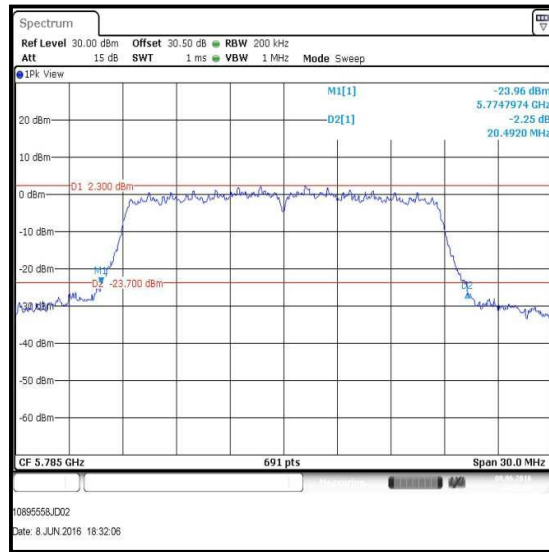

Middle Channel

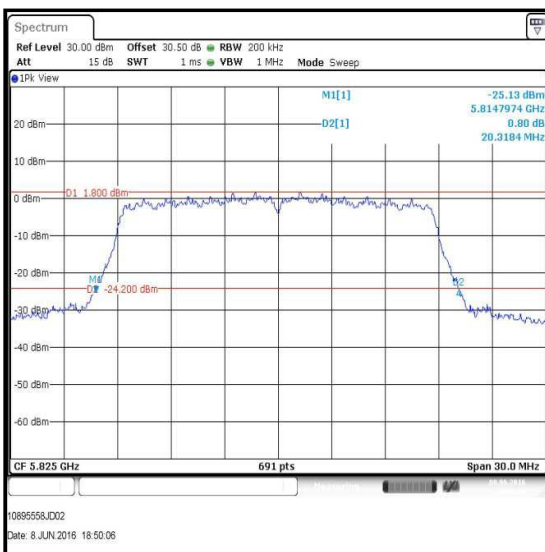

Top Channel

Transmitter 26 dB Emission Bandwidth (continued)

Results: 802.11n / 20 MHz / MIMO / 5.725-5.85 GHz band / DAC 0

Channel	Frequency (MHz)	Modulation scheme	MCS Index	26 dB Emission Bandwidth (MHz)
Bottom	5745	BPSK	0	20.318
Middle	5785	BPSK	0	20.492
Top	5825	BPSK	0	20.318



Bottom Channel



Middle Channel



Top Channel

Transmitter 26 dB Emission Bandwidth (continued)

Results: 802.11n / 20 MHz / MIMO / 5.725-5.85 GHz band / DAC 1

Channel	Frequency (MHz)	Modulation scheme	MCS Index	26 dB Emission Bandwidth (MHz)
Bottom	5745	BPSK	0	20.449
Middle	5785	BPSK	0	20.275
Top	5825	BPSK	0	20.492

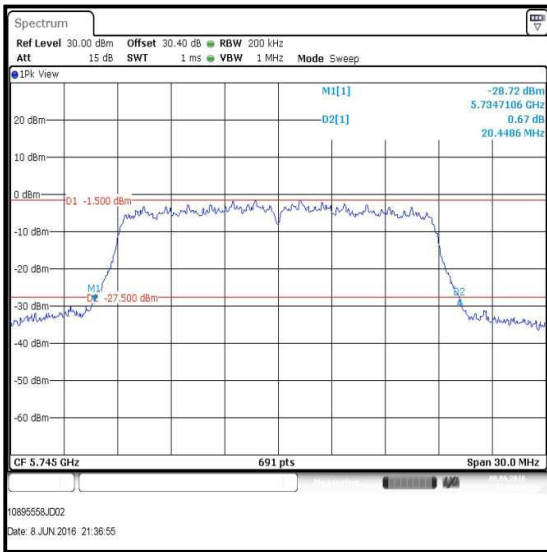

Bottom Channel



Middle Channel

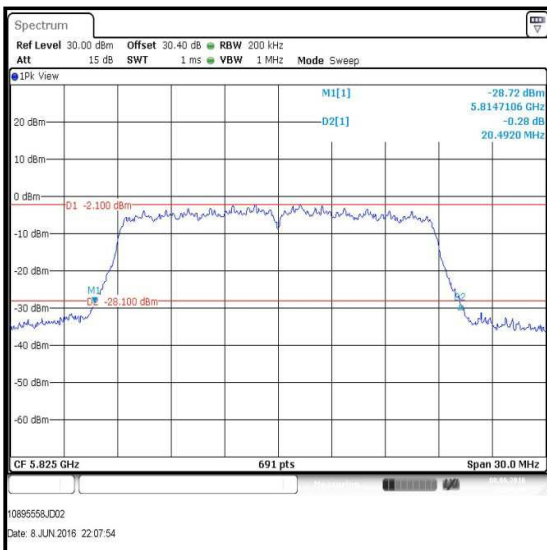

Top Channel

Transmitter 26 dB Emission Bandwidth (continued)

Results: 802.11n / 40 MHz / SISO / 5.725-5.85 GHz band / DAC 0

Channel	Frequency (MHz)	Modulation scheme	MCS Index	26 dB Emission Bandwidth (MHz)
Bottom	5755	BPSK	0	42.113
Top	5795	BPSK	0	41.592

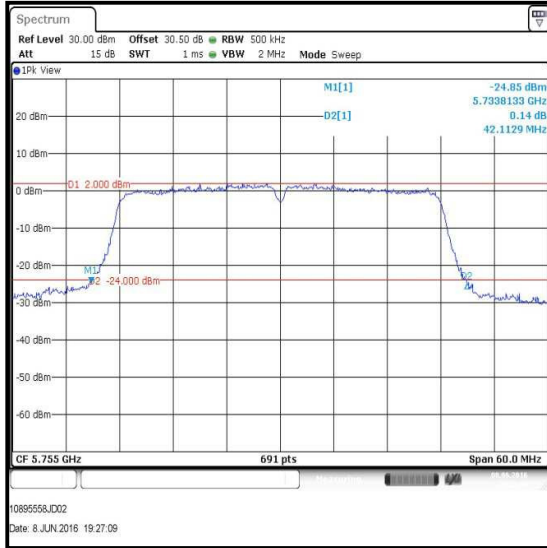

Bottom Channel

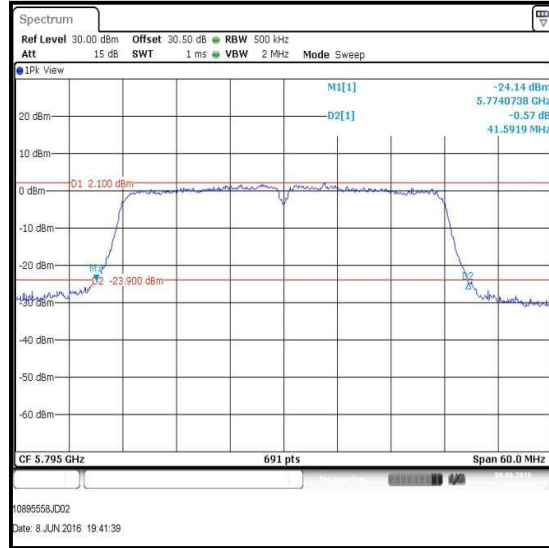

Top Channel

Transmitter 26 dB Emission Bandwidth (continued)

Results: 802.11n / 40 MHz / MIMO / 5.725-5.85 GHz band / DAC 0

Channel	Frequency (MHz)	Modulation scheme	MCS Index	26 dB Emission Bandwidth (MHz)
Bottom	5755	BPSK	0	41.939
Top	5795	BPSK	0	41.939

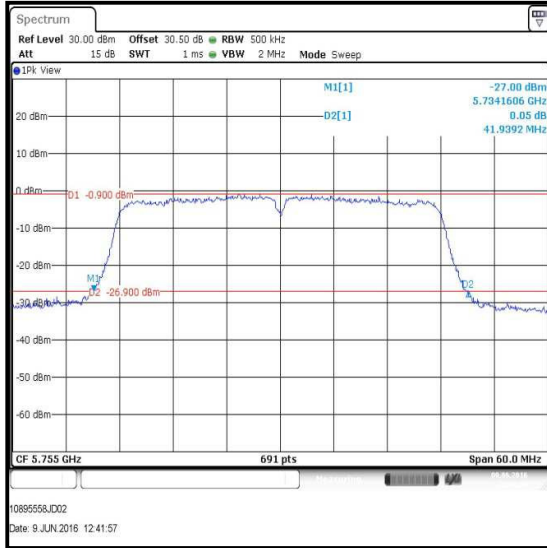

Bottom Channel



Top Channel

Transmitter 26 dB Emission Bandwidth (continued)

Results: 802.11n / 40 MHz / MIMO / 5.725-5.85 GHz band / DAC 1

Channel	Frequency (MHz)	Modulation scheme	MCS Index	26 dB Emission Bandwidth (MHz)
Bottom	5755	BPSK	0	42.894
Top	5795	BPSK	0	42.460

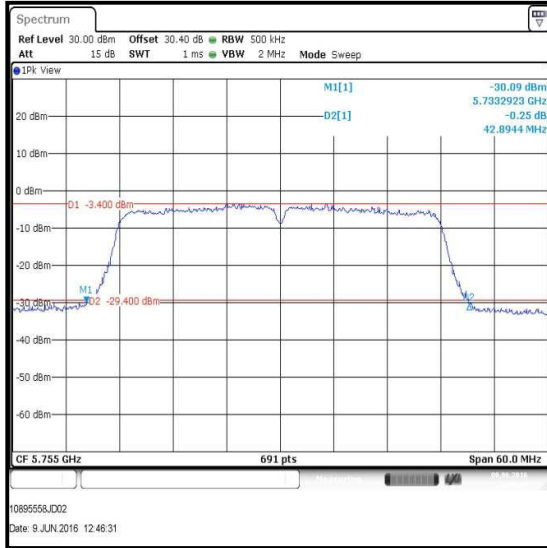

Bottom Channel



Top Channel

Transmitter 26 dB Emission Bandwidth (continued)

Results: 802.11ac / 80 MHz / SISO / 5.725-5.85 GHz band / DAC 0

Channel	Frequency (MHz)	Modulation scheme	MCS Index	26 dB Emission Bandwidth (MHz)
Single	5775	QPSK	0	81.505

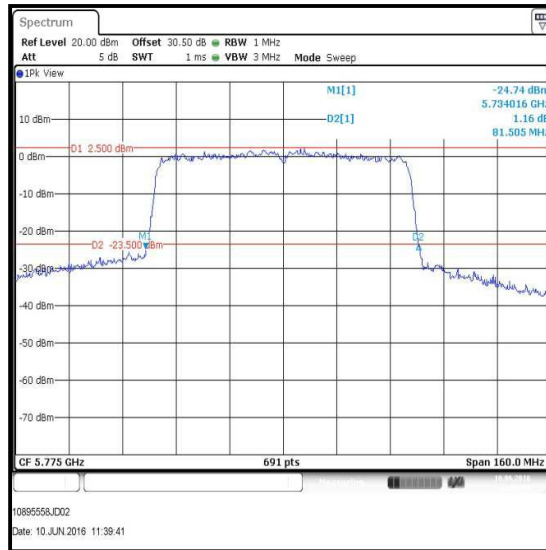

Single Channel

Transmitter 26 dB Emission Bandwidth (continued)

Results: 802.11ac / 80 MHz / MIMO / 5.725-5.85 GHz band / DAC 0

Channel	Frequency (MHz)	Modulation scheme	MCS Index	26 dB Emission Bandwidth (MHz)
Single	5775	BPSK	0	81.737

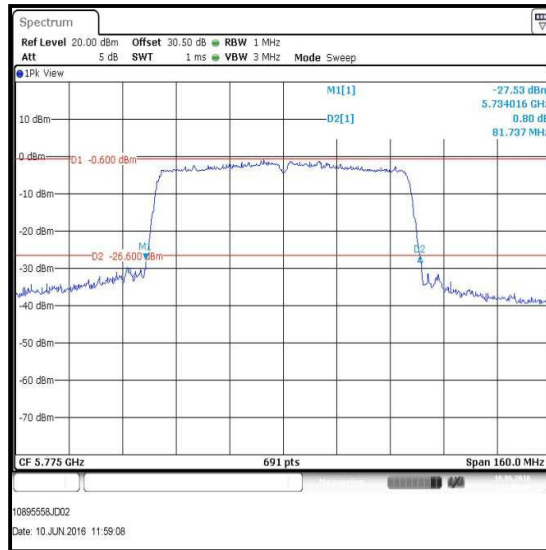

Single Channel

Results: 802.11ac / 80 MHz / MIMO / 5.725-5.85 GHz band / DAC 1

Channel	Frequency (MHz)	Modulation scheme	MCS Index	26 dB Emission Bandwidth (MHz)
Single	5775	BPSK	0	81.737

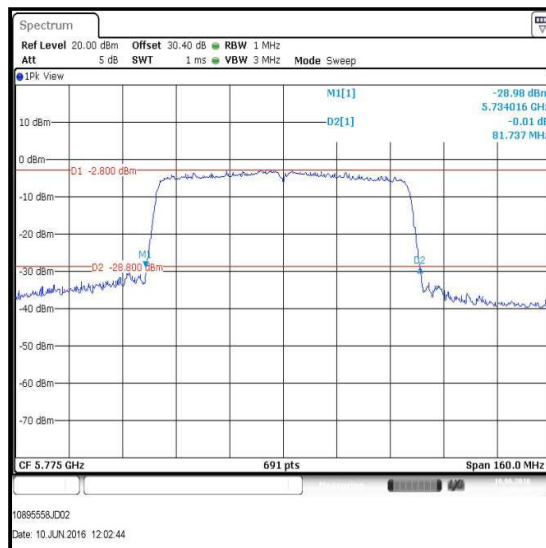

Single Channel

Transmitter 26 dB Emission Bandwidth (continued)

Results: 802.11n 20 MHz / SISO / 5.15-5.25 GHz band / DAC 0 (Reference Plots)

Channel	Frequency (MHz)	Modulation scheme	MCS Index	26 dB Emission Bandwidth (MHz)
Bottom	5180	16QAM	3	20.145
Middle	5200	16QAM	3	20.275
Top	5240	16QAM	3	20.188

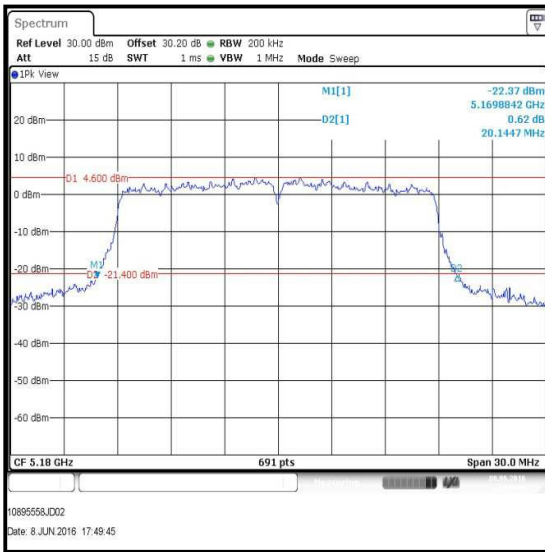

Bottom Channel



Middle Channel

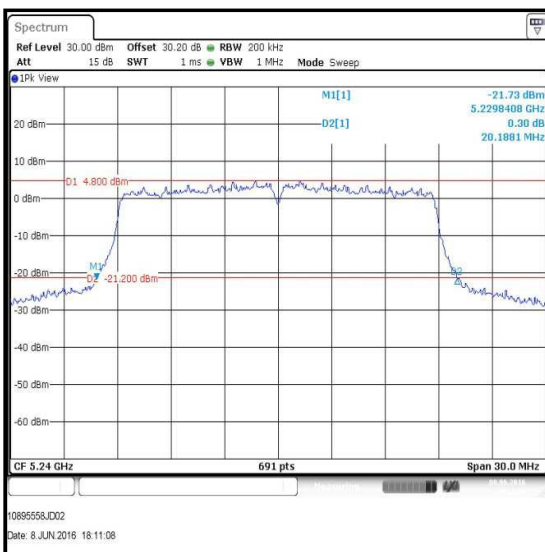

Top Channel

Transmitter 26 dB Emission Bandwidth (continued)

Results: 802.11n / 40 MHz / SISO / 5.15-5.25 GHz band / DAC 0 (Reference Plots)

Channel	Frequency (MHz)	Modulation scheme	MCS Index	26 dB Emission Bandwidth (MHz)
Bottom	5190	16QAM	3	41.852
Top	5230	16QAM	3	41.679

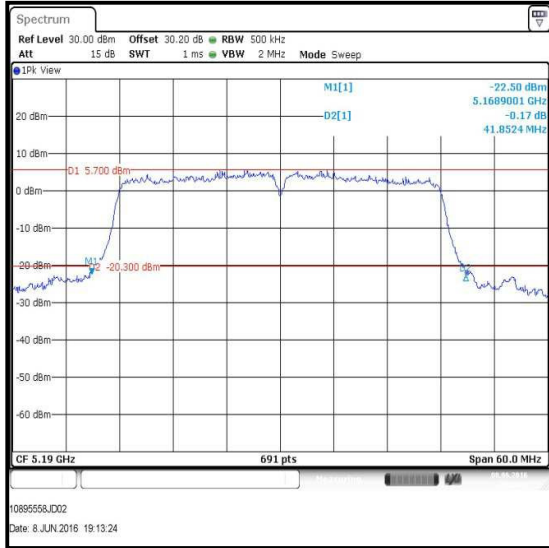

Bottom Channel



Top Channel

Transmitter 26 dB Emission Bandwidth (continued)

Results: 802.11n / 20 MHz / MIMO / 5.15-5.25 GHz band / DAC0 (Reference Plots)

Channel	Frequency (MHz)	Modulation scheme	MCS Index	26 dB Emission Bandwidth (MHz)
Bottom	5180	QPSK	1	20.188
Middle	5200	QPSK	1	20.015
Top	5240	QPSK	1	20.318



Bottom Channel



Middle Channel



Top Channel

Transmitter 26 dB Emission Bandwidth (continued)

Results: 802.11n / 20 MHz / MIMO / 5.15-5.25 GHz band / DAC1 (Reference Plots)

Channel	Frequency (MHz)	Modulation scheme	MCS Index	26 dB Emission Bandwidth (MHz)
Bottom	5180	QPSK	1	20.015
Middle	5200	QPSK	1	20.405
Top	5240	QPSK	1	20.101

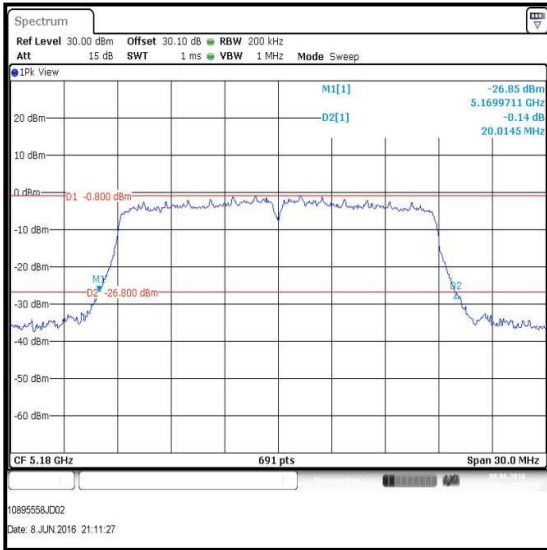

Bottom Channel

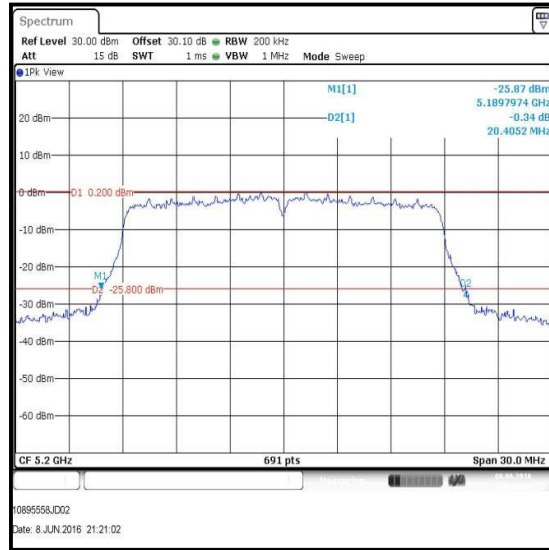

Middle Channel

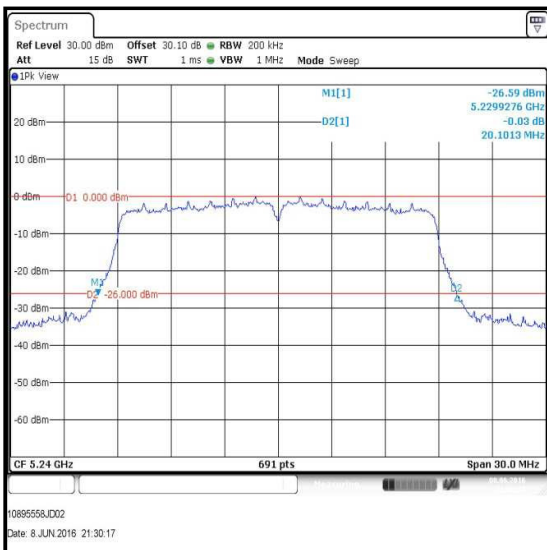

Top Channel

Transmitter 26 dB Emission Bandwidth (continued)

Results: 802.11n / 40 MHz / MIMO / 5.15-5.25 GHz band / DAC0 (Reference Plots)

Channel	Frequency (MHz)	Modulation scheme	MCS Index	26 dB Emission Bandwidth (MHz)
Bottom	5190	16QAM	3	40.637
Top	5230	16QAM	3	41.158

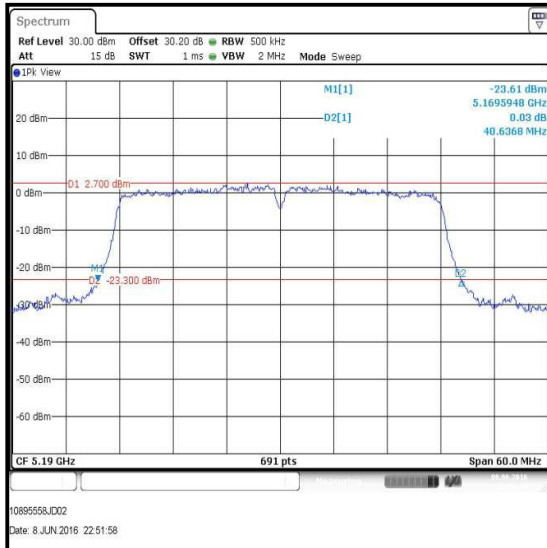

Bottom Channel



Top Channel

Transmitter 26 dB Emission Bandwidth (continued)

Results: 802.11n / 40 MHz / MIMO / 5.15-5.25 GHz band / DAC1 (Reference Plots)

Channel	Frequency (MHz)	Modulation scheme	MCS Index	26 dB Emission Bandwidth (MHz)
Bottom	5190	16QAM	3	40.984
Top	5230	16QAM	3	41.331

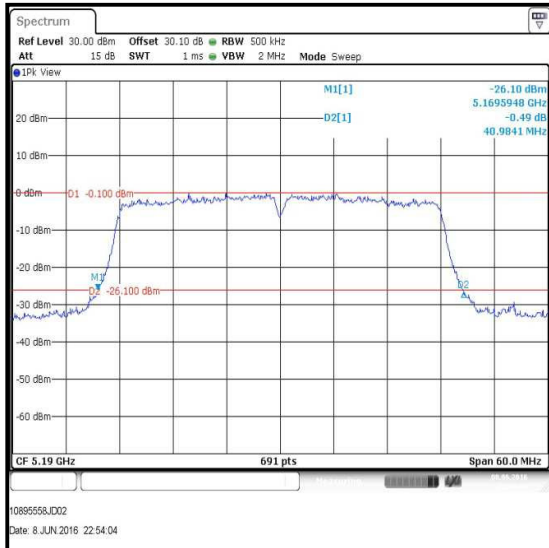

Bottom Channel

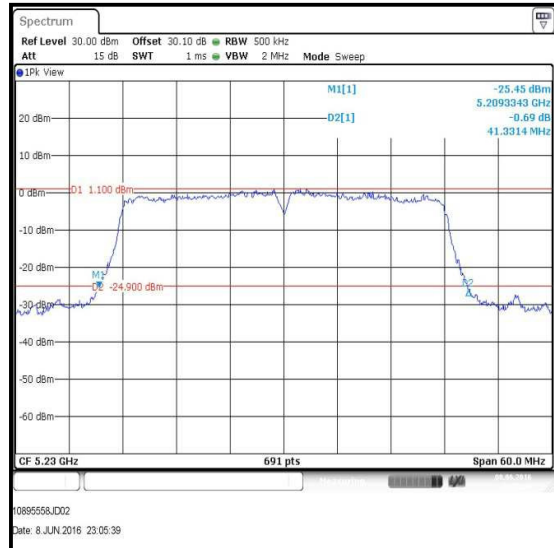

Top Channel

Transmitter 26 dB Emission Bandwidth (continued)

Results: 802.11ac / 80 MHz / MIMO / 5.15-5.25 GHz band / DAC0 (Reference Plots)

Channel	Frequency (MHz)	Modulation scheme	MCS Index	26 dB Emission Bandwidth (MHz)
Single	5210	16QAM	3	80.810

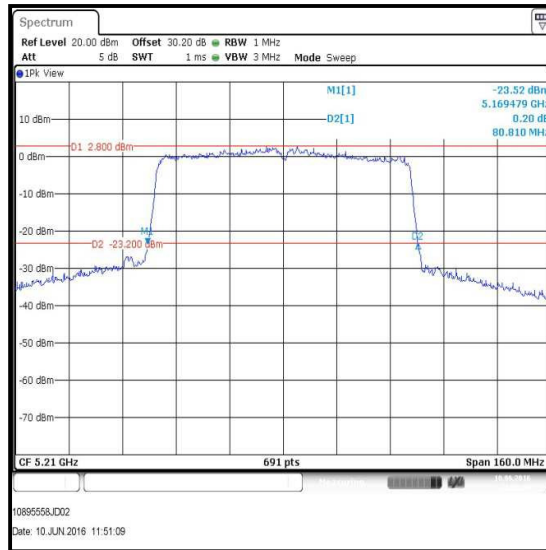

Single Channel

Results: 802.11ac / 80 MHz / MIMO / 5.15-5.25 GHz band / DAC1 (Reference Plots)

Channel	Frequency (MHz)	Modulation scheme	MCS Index	26 dB Emission Bandwidth (MHz)
Single	5210	16QAM	3	80.810

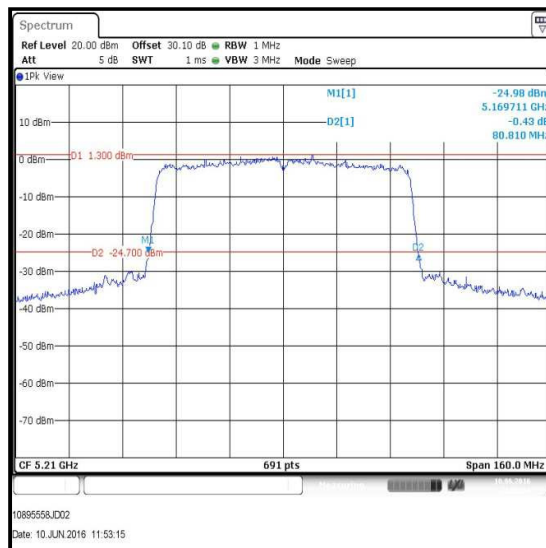

Single Channel

Transmitter 26 dB Emission Bandwidth (continued)

Results: 802.11n 20 MHz / SISO / 5.725-5.85 GHz band / DAC 0 (Reference Plots)

Channel	Frequency (MHz)	Modulation scheme	MCS Index	26 dB Emission Bandwidth (MHz)
Bottom	5745	16QAM	3	20.145
Middle	5785	16QAM	3	20.145
Top	5825	16QAM	3	20.145



Bottom Channel

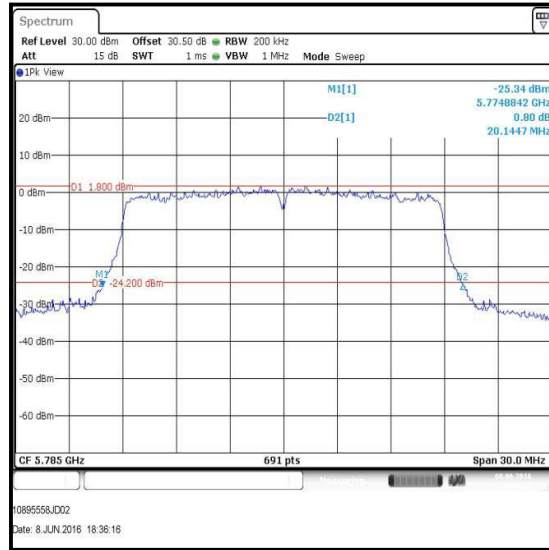

Middle Channel



Top Channel

Transmitter 26 dB Emission Bandwidth (continued)

Results: 802.11n / 40 MHz / SISO / 5.725-5.85 GHz band / DAC 0 (Reference Plots)

Channel	Frequency (MHz)	Modulation scheme	MCS Index	26 dB Emission Bandwidth (MHz)
Bottom	5755	16QAM	3	41.158
Top	5795	16QAM	3	41.592

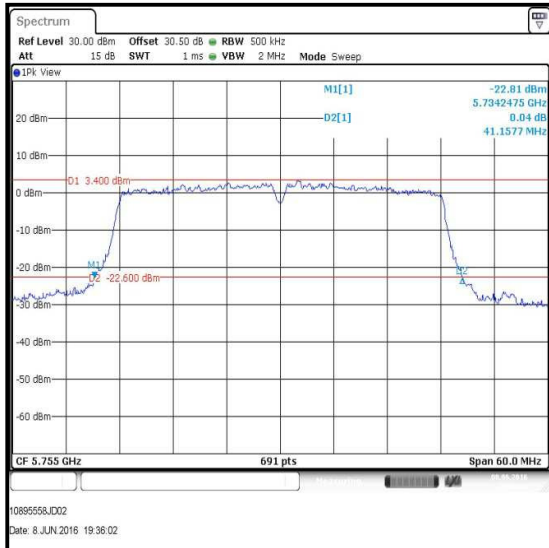

Bottom Channel



Top Channel

Transmitter 26 dB Emission Bandwidth (continued)

Results: 802.11n / 20 MHz / MIMO / QPSK / 5.725-5.85 GHz band / DAC0 (Reference Plots)

Channel	Frequency (MHz)	Modulation scheme	MCS Index	26 dB Emission Bandwidth (MHz)
Bottom	5745	QPSK	1	20.058
Middle	5785	QPSK	1	20.188
Top	5825	QPSK	1	20.145

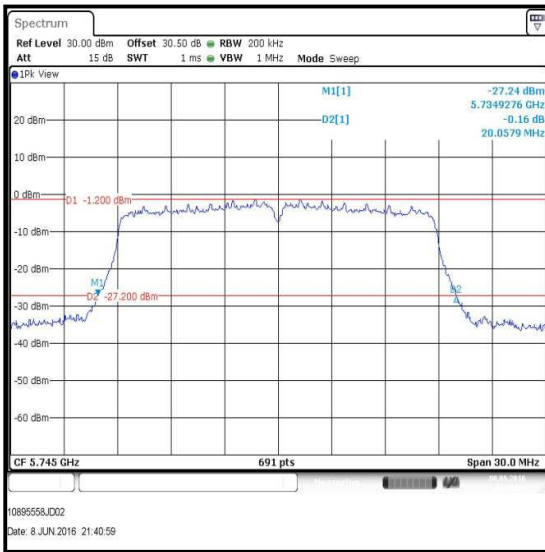

Bottom Channel

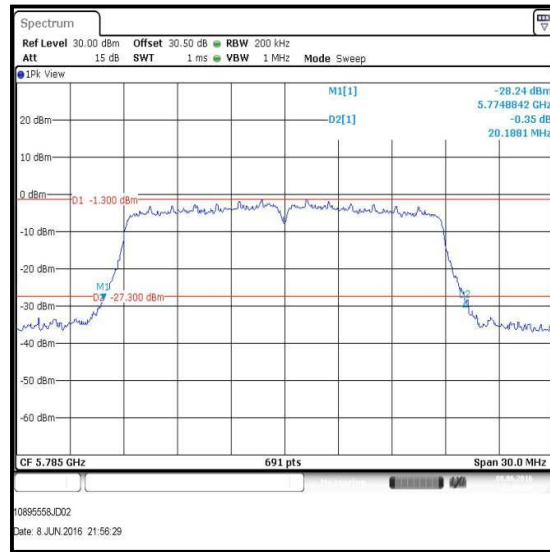

Middle Channel

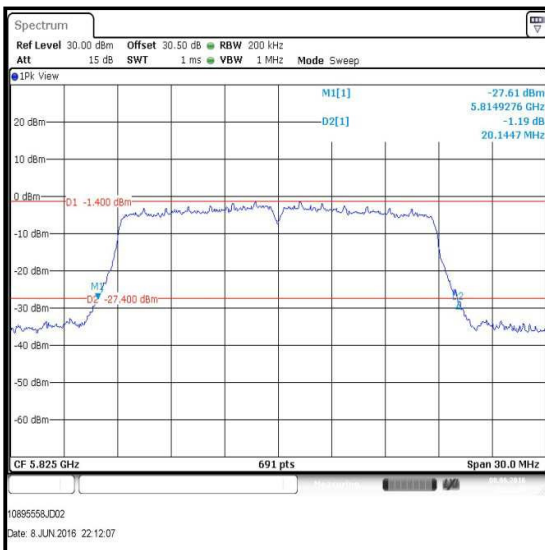

Top Channel

Transmitter 26 dB Emission Bandwidth (continued)

Results: 802.11n / 20 MHz / MIMO / QPSK / 5.725-5.85 GHz band / DAC1 (Reference Plots)

Channel	Frequency (MHz)	Modulation scheme	MCS Index	26 dB Emission Bandwidth (MHz)
Bottom	5745	QPSK	1	20.232
Middle	5785	QPSK	1	20.275
Top	5825	QPSK	1	20.318



Bottom Channel



Middle Channel



Top Channel

Transmitter 26 dB Emission Bandwidth (continued)

Results: 802.11n / 40 MHz / MIMO / 5.725-5.85 GHz band / DAC0 (Reference Plots)

Channel	Frequency (MHz)	Modulation scheme	MCS Index	26 dB Emission Bandwidth (MHz)
Bottom	5755	16QAM	3	41.245
Top	5795	16QAM	3	41.505

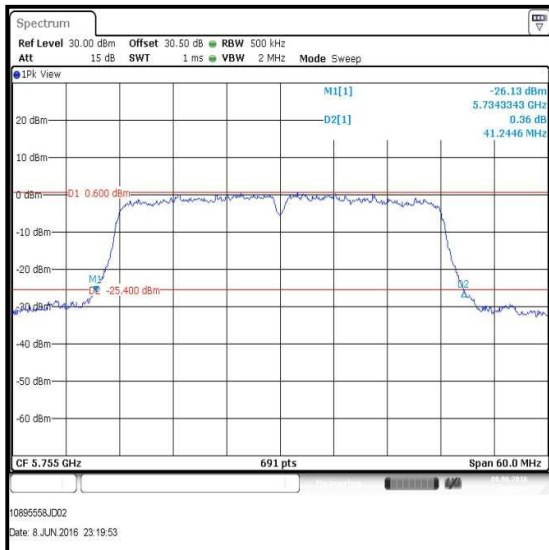

Bottom Channel

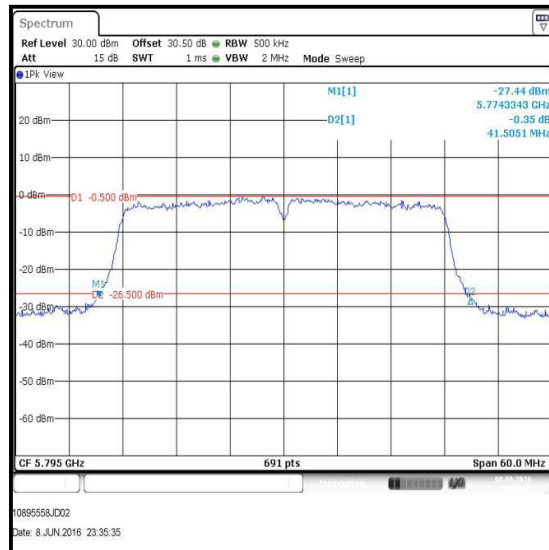

Top Channel

Transmitter 26 dB Emission Bandwidth (continued)

Results: 802.11n / 40 MHz / MIMO / 5.725-5.85 GHz band / DAC1 (Reference Plots)

Channel	Frequency (MHz)	Modulation scheme	MCS Index	26 dB Emission Bandwidth (MHz)
Bottom	5755	16QAM	3	41.679
Top	5795	16QAM	3	41.331

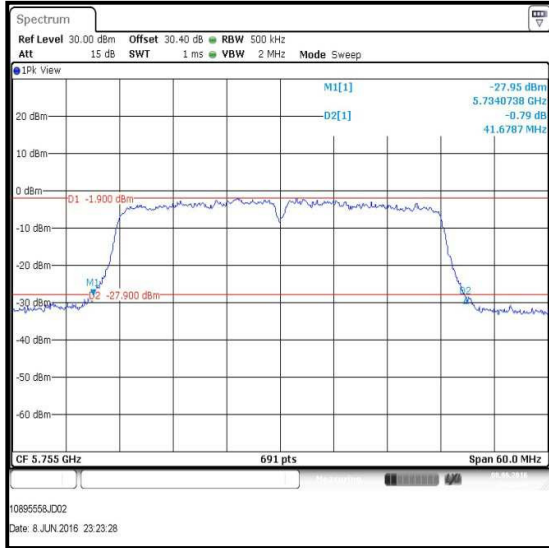

Bottom Channel

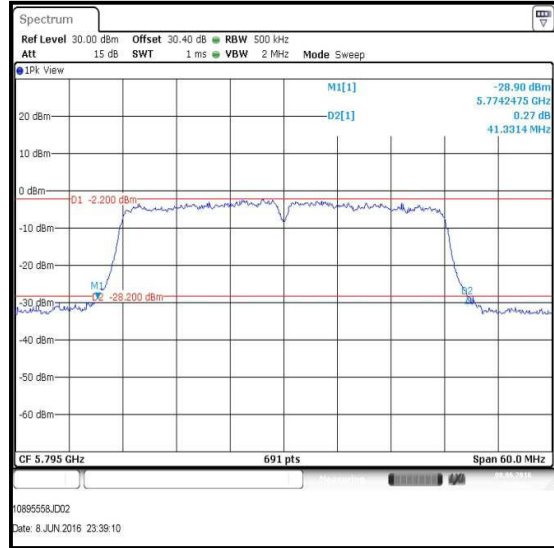

Top Channel

Transmitter 26 dB Emission Bandwidth (continued)

Results: 802.11ac / 80 MHz / MIMO / 5.725-5.85 GHz band / DAC0 (Reference Plots)

Channel	Frequency (MHz)	Modulation scheme	MCS Index	26 dB Emission Bandwidth (MHz)
Single	5775	16QAM	3	80.810



Single Channel

Results: 802.11ac / 80 MHz / MIMO / 5.725-5.85 GHz band / DAC1 (Reference Plots)

Channel	Frequency (MHz)	Modulation scheme	MCS Index	26 dB Emission Bandwidth (MHz)
Single	5775	16QAM	3	81.042

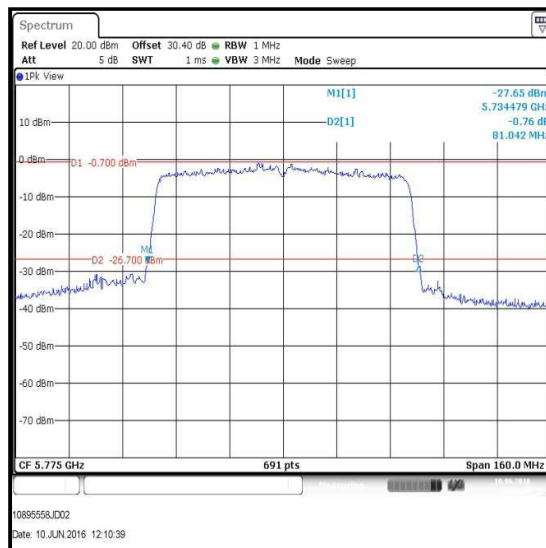

Single Channel

Transmitter 26 dB Emission Bandwidth (continued)**Test Equipment Used:**

Asset No.	Instrument	Manufacturer	Type No.	Serial No.	Date Calibration Due	Cal. Interval (Months)
M2004	Thermohygrometer	JM Handelspunkt	30.5015.13	Not stated	02 Apr 2017	12
M1835	Signal Analyser	Rohde & Schwarz	FSV30	103050	26 Feb 2017	12
M1867	Attenuator	Huber + Suhner AG	6820.17.B	07101	Calibrated before use	-
A2847	Attenuator	Radiall	R411.820.121	24671450	Calibrated before use	-
A2345	Attenuator	Macom	2082-6043-20	None stated	Calibrated before use	-
A2009	RF Switch	Pickering Interfaces	64-102-002 & 40-881-001	XZ340281 & X311198	Calibrated before use	-
S0538	DC Power Supply	TTi	PL154	250135	Calibrated before use	-
M1818	Multimeter	Fluke	79III	71811580	27 Apr 2017	12
M1252	Signal Generator	Hewlett Packard	83640A	3119A00489	26 Oct 2017	24

5.2.3. Transmitter Minimum 6 dB Bandwidth (5.725-5.85 GHz band)**Test Summary:**

Test Engineer:	Georgios Vrezas	Test Dates:	08 June 2016 & 09 June 2016
Test Sample MAC address:	542AA22F8F19		

FCC Reference:	Part 15.407(e)
Test Method Used:	KDB 789033 D02 Section II.C.2.

Environmental Conditions:

Temperature (°C):	23 to 25
Relative Humidity (%):	48 to 53

Note(s):

1. All configurations supported by the EUT were investigated on one channel in accordance with KDB 789033 Section II.C.2. Minimum Emission Bandwidth for the band 5.725-5.85 GHz measurement procedure. The data rates that produced the narrowest bandwidth and therefore deemed worst case were:
 - 802.11a – BPSK / 6 Mbps
 - 802.11a CDD – BPSK / 6 Mbps
 - 802.11n HT20 SISO – BPSK / 6.5 Mbps / MCS0
 - 802.11n HT40 SISO – BPSK / 13.5 Mbps / MCS0
 - 802.11n HT20 MIMO – BPSK / 6.5 Mbps / MCS0
 - 802.11n HT40 MIMO – BPSK / 13.5 Mbps / MCS0
 - 802.11ac VHT80 SISO – BPSK / 29.3 Mbps / MCS0
 - 802.11ac VHT80 MIMO – BPSK / 29.3 Mbps / MCS0
2. Final measurements were performed using the above configurations on the bottom, middle and top channels.
3. Measurements were performed on both ports and found to be identical. Therefore, only results for DAC 0 are presented in the section of the test report.
4. Plots for all data rates on both ports are archived on the UL VS LTD IT server and available for inspection upon request.
5. The signal analyser was connected to the RF port on the EUT using suitable attenuation and RF cable.

Transmitter Minimum 6 dB Bandwidth (5.725-5.85 GHz band) (continued)

Test setup:

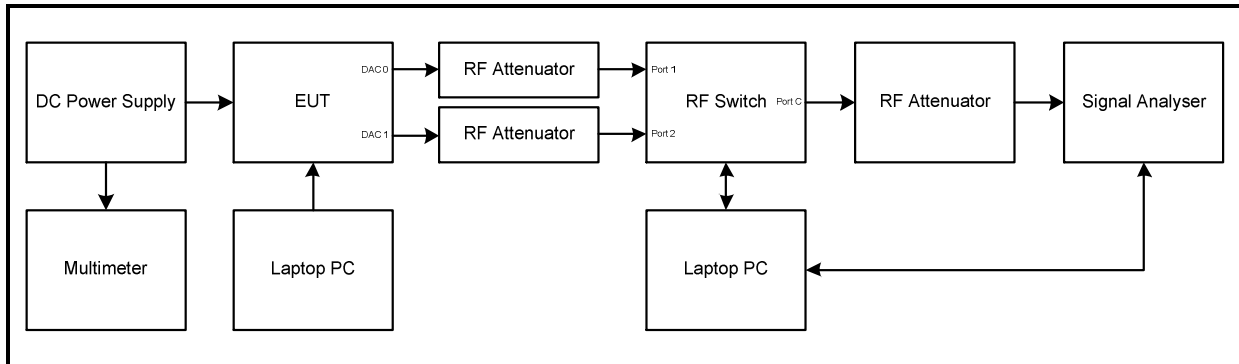

Transmitter Minimum 6 dB Bandwidth (5.725-5.85 GHz band) (continued)

Results: 802.11a / 20 MHz / BPSK / 6 Mbps / DAC 0

Channel	6 dB Bandwidth (kHz)	Limit (kHz)	Margin (kHz)	Result
Bottom	15890	≥500	15390	Complied
Middle	15890	≥500	15390	Complied
Top	16324	≥500	15824	Complied

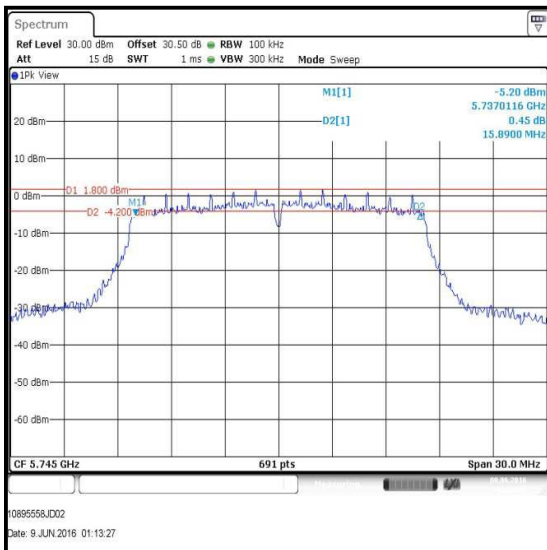

Bottom Channel

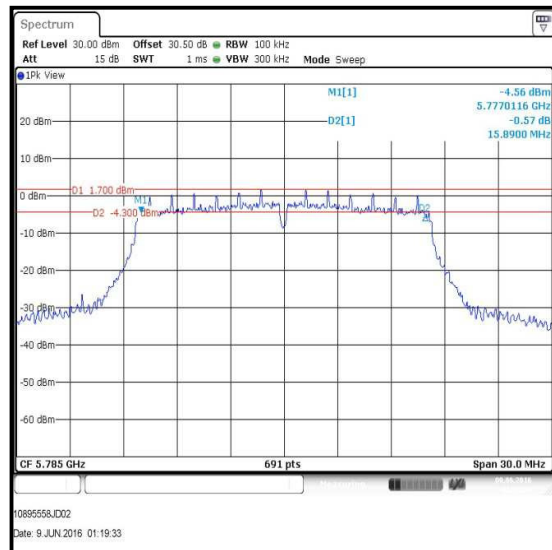

Middle Channel

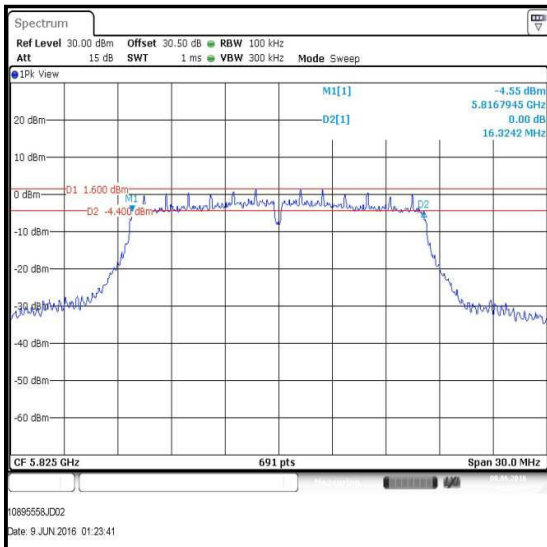

Top Channel

Transmitter Minimum 6 dB Bandwidth (5.725-5.85 GHz band) (continued)

Results: 802.11a / 20 MHz / BPSK / 6 Mbps / CDD / DAC 0

Channel	6 dB Bandwidth (kHz)	Limit (kHz)	Margin (kHz)	Result
Bottom	16324	≥500	15824	Complied
Middle	16107	≥500	15607	Complied
Top	16368	≥500	15868	Complied

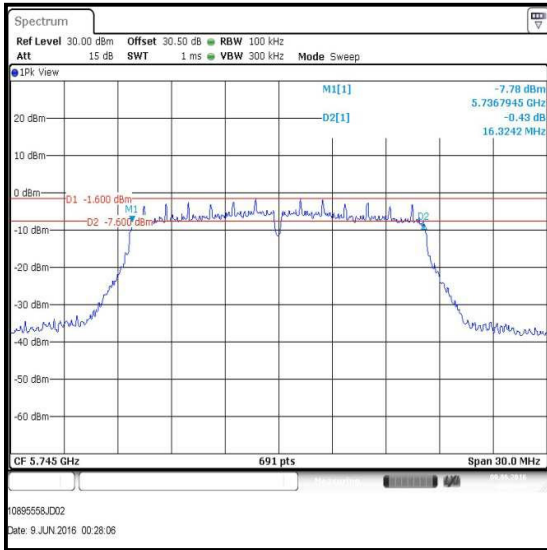

Bottom Channel

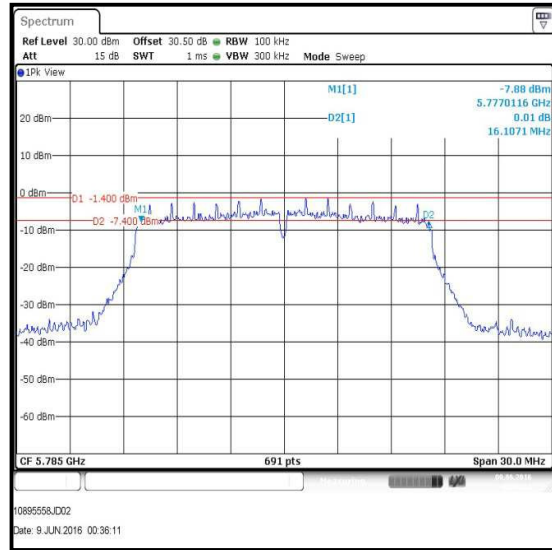

Middle Channel

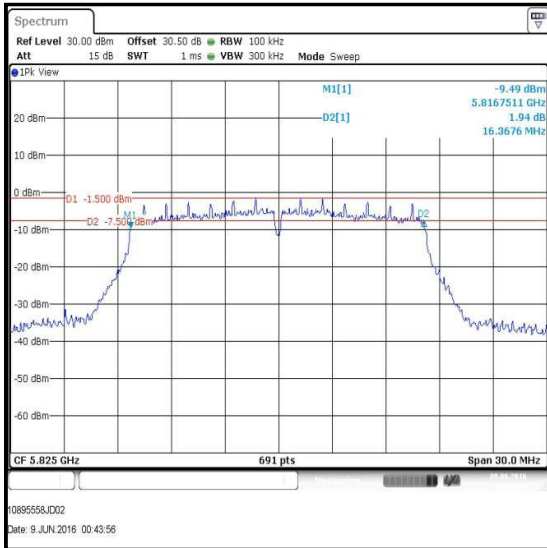

Top Channel

Transmitter Minimum 6 dB Bandwidth (5.725-5.85 GHz band) (continued)

Results: 802.11n / 20 MHz / SISO / BPSK / MCS0 / DAC 0

Channel	6 dB Bandwidth (kHz)	Limit (kHz)	Margin (kHz)	Result
Bottom	17019	≥500	16519	Complied
Middle	16975	≥500	16475	Complied
Top	17106	≥500	16606	Complied

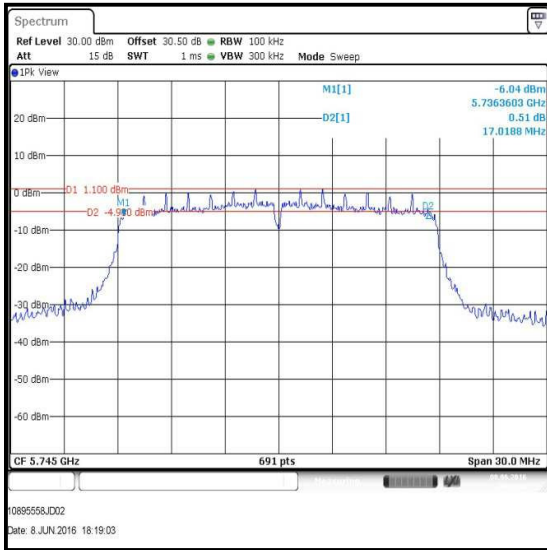

Bottom Channel

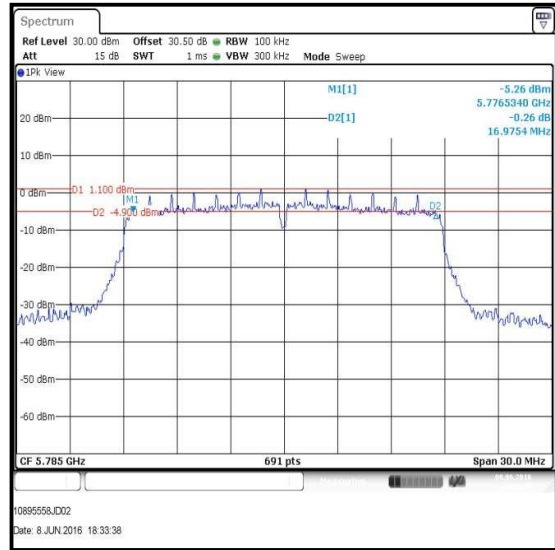

Middle Channel

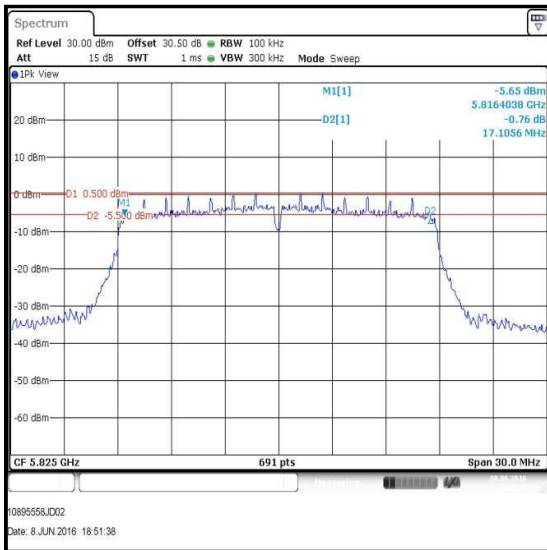

Top Channel

Transmitter Minimum 6 dB Bandwidth (5.725-5.85 GHz band) (continued)

Results: 802.11n / 20 MHz / MIMO / BPSK / MCS0 / DAC 0

Channel	6 dB Bandwidth (kHz)	Limit (kHz)	Margin (kHz)	Result
Bottom	16324	≥500	15824	Complied
Middle	17106	≥500	16606	Complied
Top	17106	≥500	16606	Complied

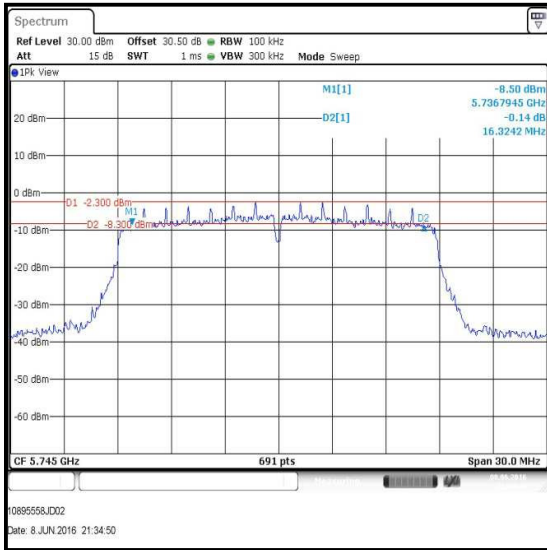

Bottom Channel

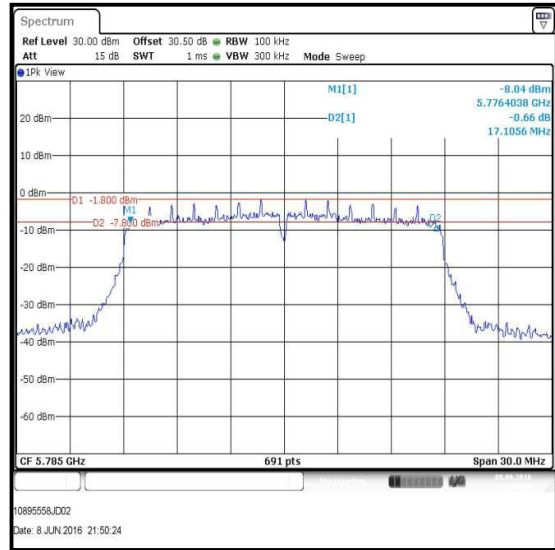

Middle Channel

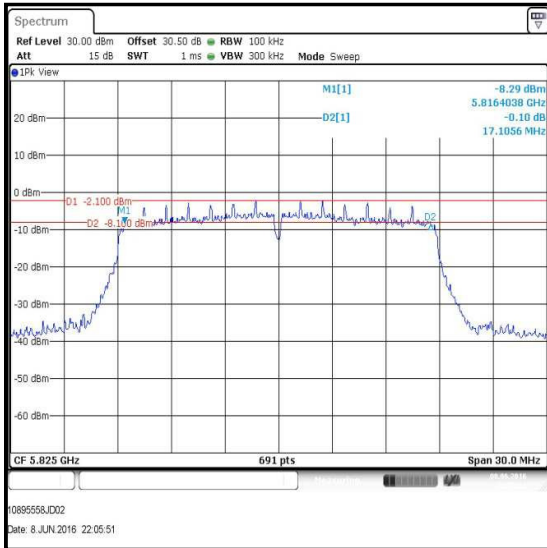

Top Channel

Transmitter Minimum 6 dB Bandwidth (5.725-5.85 GHz band) (continued)

Results: 802.11n / 40 MHz / SISO / BPSK / MCS0 / DAC 0

Channel	6 dB Bandwidth (kHz)	Limit (kHz)	Margin (kHz)	Result
Bottom	35340	≥500	34840	Complied
Top	35340	≥500	34840	Complied



Bottom Channel

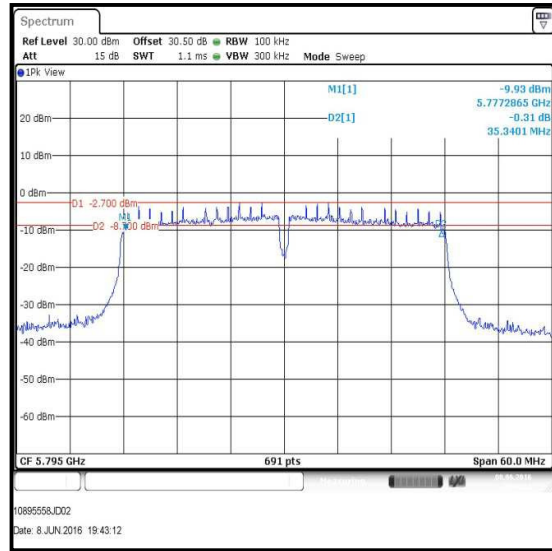

Top Channel

Transmitter Minimum 6 dB Bandwidth (5.725-5.85 GHz band) (continued)

Results: 802.11n / 40 MHz / MIMO / BPSK / MCS0 / DAC 0

Channel	6 dB Bandwidth (kHz)	Limit (kHz)	Margin (kHz)	Result
Bottom	35340	≥500	34840	Complied
Top	35340	≥500	34840	Complied

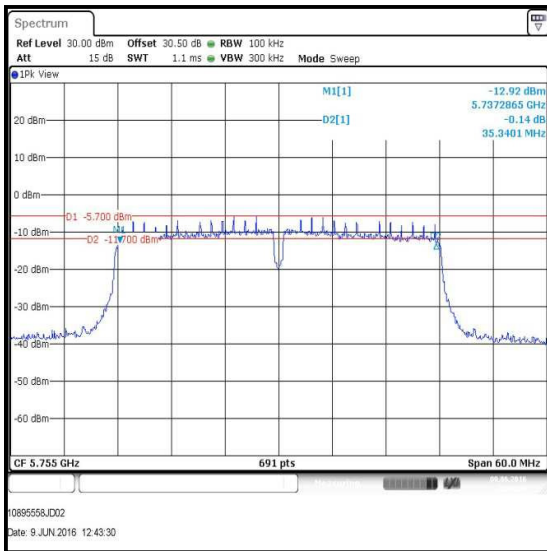

Bottom Channel

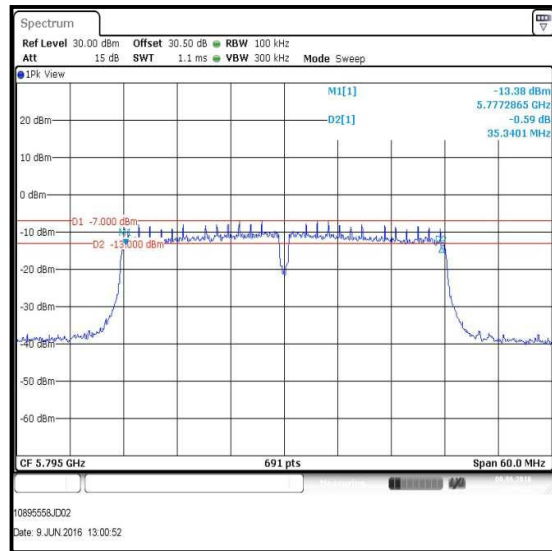

Top Channel

Transmitter Minimum 6 dB Bandwidth (5.725-5.85 GHz band) (continued)

Results: 802.11ac / 80 MHz / SISO / BPSK / MCS0 / DAC 0

Channel	6 dB Bandwidth (kHz)	Limit (kHz)	Margin (kHz)	Result
Single	75369	≥500	74869	Complied



Single Channel

Results: 802.11ac / 80 MHz / MIMO / BPSK / MCS0 / DAC0

Channel	6 dB Bandwidth (kHz)	Limit (kHz)	Margin (kHz)	Result
Top	75369	≥500	74869	Complied

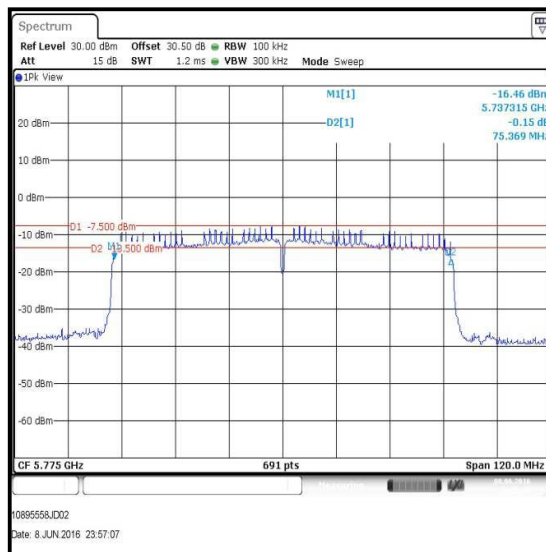

Single Channel

Transmitter Minimum 6 dB Bandwidth (5.725-5.85 GHz band) (continued)**Test Equipment Used:**

Asset No.	Instrument	Manufacturer	Type No.	Serial No.	Date Calibration Due	Cal. Interval (Months)
M2004	Thermohygrometer	JM Handelspunkt	30.5015.13	Not stated	02 Apr 2017	12
M1835	Signal Analyser	Rohde & Schwarz	FSV30	103050	26 Feb 2017	12
M1867	Attenuator	Huber + Suhner AG	6820.17.B	07101	Calibrated before use	-
A2847	Attenuator	Radiall	R411.820.121	24671450	Calibrated before use	-
A2345	Attenuator	Macom	2082-6043-20	None stated	Calibrated before use	-
A2009	RF Switch	Pickering Interfaces	64-102-002 & 40-881-001	XZ340281 & X311198	Calibrated before use	-
S0538	DC Power Supply	TTi	PL154	250135	Calibrated before use	-
M1818	Multimeter	Fluke	79III	71811580	27 Apr 2017	12
M1252	Signal Generator	Hewlett Packard	83640A	3119A00489	26 Oct 2017	24