



# TEST REPORT

**Test Report No. : UL-RPT-RP10895558JD02A V2.0**

**Manufacturer** : Bang & Olufsen a/s  
**Model No.** : WUS-AC08V  
**FCC ID** : TTUWUSAC08V  
**Technology** : WLAN  
**Test Standard(s)** : FCC Parts 15.207, 15.209(a) & 15.247

1. This test report shall not be reproduced in full or partial, without the written approval of UL VS LTD.
2. The results in this report apply only to the sample(s) tested.
3. The sample tested is in compliance with the above standard(s).
4. The test results in this report are traceable to the national or international standards.
5. Version 2.0 supersedes all previous versions.

**Date of Issue:** 19 December 2016

**Checked by:**

Sarah Williams  
Engineer, Radio Laboratory

**Company Signatory:**

Ian Watch  
Senior Engineer, Radio Laboratory  
UL VS LTD



This laboratory is accredited by UKAS.  
The tests reported herein have been  
performed in accordance with its terms  
of accreditation.

---

**UL VS LTD**

Pavilion A, Ashwood Park, Ashwood Way, Basingstoke, Hampshire, RG23 8BG, UK  
Telephone: +44 (0)1256 312000  
Facsimile: +44 (0)1256 312001

This page has been left intentionally blank.

## **Table of Contents**

<b>1. Customer Information.....</b>	<b>4</b>
<b>2. Summary of Testing.....</b>	<b>5</b>
2.1. General Information	5
2.2. Summary of Test Results	5
2.3. Methods and Procedures	6
2.4. Deviations from the Test Specification	6
<b>3. Equipment Under Test (EUT) .....</b>	<b>7</b>
3.1. Identification of Equipment Under Test (EUT)	7
3.2. Description of EUT	7
3.3. Modifications Incorporated in the EUT	7
3.4. Additional Information Related to Testing	8
3.5. Support Equipment	9
Support Equipment (continued)	10
<b>4. Operation and Monitoring of the EUT during Testing .....</b>	<b>13</b>
4.1. Operating Modes	13
4.2. Configuration and Peripherals	13
4.3. Power Settings	14
<b>5. Measurements, Examinations and Derived Results.....</b>	<b>15</b>
5.1. General Comments	15
5.2. Test Results	16
5.2.1. Transmitter AC Conducted Spurious Emissions	16
5.2.2. Transmitter Minimum 6 dB Bandwidth	22
5.2.3. Transmitter Duty Cycle	28
5.2.4. Transmitter Power Spectral Density	33
5.2.5. Transmitter Maximum (Average) Output Power	47
5.2.6. Transmitter Radiated Emissions	66
5.2.7. Transmitter Band Edge Radiated Emissions	74
<b>6. Measurement Uncertainty .....</b>	<b>94</b>
<b>7. Report Revision History .....</b>	<b>95</b>

### **1. Customer Information**









<b>Company Name:</b>	Bang & Olufsen A/S
<b>Address:</b>	Peter Bangs Vej 15 7600 Struer Denmark

## **2. Summary of Testing**

### **2.1. General Information**

<b>Specification Reference:</b>	47CFR15.247
<b>Specification Title:</b>	Code of Federal Regulations Volume 47 (Telecommunications): Part 15 Subpart C (Intentional Radiators) - Section 15.247
<b>Specification Reference:</b>	47CFR15.207 and 47CFR15.209
<b>Specification Title:</b>	Code of Federal Regulations Volume 47 (Telecommunications): Part 15 Subpart C (Intentional Radiators) - Sections 15.207 and 15.209
<b>Site Registration:</b>	209735
<b>Location of Testing:</b>	UL VS LTD, Unit 3 Horizon, Wade Road, Kingsland Business Park, Basingstoke, Hampshire, RG24 8AH, United Kingdom
<b>Test Dates:</b>	09 November 2015 to 22 April 2016

### **2.2. Summary of Test Results**

<b>FCC Reference (47CFR)</b>	<b>Measurement</b>	<b>Result</b>
Part 15.207	Transmitter AC Conducted Emissions	
Part 15.247(a)(2)	Transmitter Minimum 6 dB Bandwidth	
Part 15.35(c)	Transmitter Duty Cycle	Note 1
Part 15.247(e)	Transmitter Power Spectral Density	
Part 15.247(b)(3)	Transmitter Maximum (Average) Output Power	
Part 15.247(d) & 15.209(a)	Transmitter Radiated Emissions	
Part 15.247(d) & 15.209(a)	Transmitter Band Edge Radiated Emissions	
<b>Key to Results</b>		
 = Complied  = Did not comply		

#### **Note(s):**

1. The measurement was performed to assist in the calculation of the level of maximum conducted output power, power spectral density and emissions. The EUT cannot transmit continuously and sweep triggering/signal gating cannot be implemented.

### **2.3. Methods and Procedures**

<b>Reference:</b>	ANSI C63.10-2013
<b>Title:</b>	American National Standard of Procedures for Compliance Testing of Unlicensed Wireless Devices
<b>Reference:</b>	KDB 558074 D01 DTS Meas Guidance v03r05 April 8, 2016
<b>Title:</b>	Guidance for Performing Compliance Measurements on Digital Transmission Systems (DTS) Operating Under §15.247
<b>Reference:</b>	KDB 662911 D01 Multiple Transmitter Output v02r01 October 31, 2013
<b>Title:</b>	Emissions Testing of Transmitters with Multiple Outputs in the Same Band
<b>Reference:</b>	KDB 174176 D01 Line Conducted FAQ v01r01 June 3, 2015
<b>Title:</b>	AC Power-line Conducted Emissions Frequently asked questions.

### **2.4. Deviations from the Test Specification**

For the measurements contained within this test report, there were no deviations from, additions to, or exclusions from the test specification identified above.

### **3. Equipment Under Test (EUT)**

#### **3.1. Identification of Equipment Under Test (EUT)**

<b>Brand Name:</b>	WUS-AC08V
<b>Model Name or Number:</b>	WUS-AC08V
<b>Test Sample MAC address:</b>	542AA22F8F19 ( <i>Conducted sample</i> )
<b>Hardware Version:</b>	A1G
<b>Software Version:</b>	4.2.3.5
<b>FCC ID:</b>	TTUWUSAC08V

##### **3.1.1 Host Product Details**

<b>Brand Name:</b>	BeoVision Avant 55 NG
<b>Model Name or Number:</b>	BeoVision Avant 55 NG
<b>Test Sample Serial Number:</b>	92777 ( <i>Radiated sample</i> )
<b>Hardware Version:</b>	8009004
<b>Software Version:</b>	7.77

<b>Description:</b>	AC power cable
<b>Brand Name:</b>	Not marked or stated
<b>Model Name or Number:</b>	Not marked or stated
<b>Serial Number:</b>	Not marked or stated

#### **3.2. Description of EUT**

The equipment under test was a *Bluetooth* Basic Rate + EDR, *Bluetooth* Low Energy, IEEE 802.11a,b,g,n,ac WLAN module operating in the 2.4 GHz and 5 GHz bands, which was incorporated into a 55" Television. The EUT has two external antenna ports with two transmit chains and MIMO is supported. For 802.11a/g/n/ac operation the device uses two by two MIMO transmitters. Depending on the 802.11 data rate, the device transmits 1 or 2 spatial stream. The device uses spatial multiplexing and from an RF point of view the streams are correlated.

#### **3.3. Modifications Incorporated in the EUT**

No modifications were applied to the EUT during testing.

**3.4. Additional Information Related to Testing**

<b>Technology Tested:</b>	WLAN (IEEE 802.11b,g,n) / Digital Transmission System		
<b>Type of Unit:</b>	Transceiver		
<b>Modulation Type:</b>	DBPSK, DQPSK, BPSK, QPSK, 16QAM & 64QAM		
<b>Data Rates:</b>	802.11b (SISO)	1, 2, 5.5 & 11 Mbps	
	802.11g	6, 9, 12, 18, 24, 36, 48 & 54 Mbps (SISO, or MIMO with CDD)	
	802.11n HT20	MCS0 to MCS7 (1 spatial streams with either SISO, or 2-chain MIMO with CDD) MCS8 to MCS15 (2 spatial streams on 2 transmit chains)	
	802.11n HT40	MCS0 to MCS7 (1 spatial streams with either SISO, or 2-chain MIMO with CDD) MCS8 to MCS15 (2 spatial streams on 2 transmit chains)	
<b>Power Supply Requirement(s):</b>	Nominal	Module	3.3 VDC
		TV	120/240 VAC 60 Hz
<b>Maximum Conducted Output Power:</b>	13.3 dBm		
<b>Declared Antenna Gains:</b>	Antennas 1 and 2	5.4 dBi	
<b>Channel Spacing:</b>	20 MHz		
<b>Transmit Frequency Range:</b>	2412 MHz to 2462 MHz		
<b>Transmit Channels Tested:</b>	<b>Channel Number</b>	<b>Channel Frequency (MHz)</b>	
	1	2412	
	6	2437	
	11	2462	
<b>Channel Spacing:</b>	40 MHz		
<b>Transmit Frequency Range:</b>	2422 MHz to 2452 MHz		
<b>Transmit Channels Tested:</b>	<b>Channel Number</b>	<b>Channel Frequency (MHz)</b>	
	3	2422	
	9	2452	



### **3.5. Support Equipment**

The following support equipment was used to exercise the EUT during testing:

<b>Description:</b>	Laptop Computer
<b>Brand Name:</b>	Lenovo
<b>Model Name or Number:</b>	E555
<b>Serial Number:</b>	Not stated

<b>Description:</b>	USB Interface Adapter
<b>Brand Name:</b>	Not stated
<b>Model Name or Number:</b>	Not stated
<b>Serial Number:</b>	Not stated

<b>Description:</b>	USB-A to USB-B cable
<b>Brand Name:</b>	Not stated
<b>Model Name or Number:</b>	Not stated
<b>Serial Number:</b>	Not stated

<b>Description:</b>	Remote control for 55" Television
<b>Brand Name:</b>	Bang & Olufsen a/s
<b>Model Name or Number:</b>	BeoRemote One T30
<b>Serial Number:</b>	25143484

<b>Description:</b>	External BTLE box to turn on the TV
<b>Brand Name:</b>	Alpha Network
<b>Model Name or Number:</b>	WUS-AC08V
<b>Serial Number:</b>	H11145216

<b>Description:</b>	HDMI cable. Quantity 4. Length 2m
<b>Brand Name:</b>	Not marked or stated
<b>Model Name or Number:</b>	Not marked or stated
<b>Serial Number:</b>	Not marked or stated

<b>Description:</b>	Now TV set top box
<b>Brand Name:</b>	Sky
<b>Model Name or Number:</b>	2400SK
<b>Serial Number:</b>	1MM4DE006281

**Support Equipment (continued)**

<b>Description:</b>	Now TV set top box
<b>Brand Name:</b>	Sky
<b>Model Name or Number:</b>	2400SK
<b>Serial Number:</b>	1MM4D8006255

<b>Description:</b>	HDMI media player
<b>Brand Name:</b>	SUMVISION
<b>Model Name or Number:</b>	Cyclone Micro
<b>Serial Number:</b>	SUM091104017

<b>Description:</b>	Ethernet cable. Quantity 3. Length 2m
<b>Brand Name:</b>	Not marked or stated
<b>Model Name or Number:</b>	Not marked or stated
<b>Serial Number:</b>	Not marked or stated

<b>Description:</b>	Ethernet cable. Quantity 3. Length 3m
<b>Brand Name:</b>	Not marked or stated
<b>Model Name or Number:</b>	Not marked or stated
<b>Serial Number:</b>	Not marked or stated

<b>Description:</b>	Ethernet cable. Quantity 1. Length 5m
<b>Brand Name:</b>	Not marked or stated
<b>Model Name or Number:</b>	Not marked or stated
<b>Serial Number:</b>	Not marked or stated

<b>Description:</b>	Ethernet cable. Quantity 1. Length 10m
<b>Brand Name:</b>	Not marked or stated
<b>Model Name or Number:</b>	Not marked or stated
<b>Serial Number:</b>	Not marked or stated

<b>Description:</b>	5 port switch
<b>Brand Name:</b>	Netgear
<b>Model Name or Number:</b>	GS605 v3
<b>Serial Number:</b>	1YG194390218E

**Support Equipment (continued)**

<b>Description:</b>	5 port switch
<b>Brand Name:</b>	Netgear
<b>Model Name or Number:</b>	GS605 v3
<b>Serial Number:</b>	1YG19430021A1

<b>Description:</b>	3.5 mm Male to 2xRCA male audio cable
<b>Brand Name:</b>	Not marked or stated
<b>Model Name or Number:</b>	Not marked or stated
<b>Serial Number:</b>	Not marked or stated

<b>Description:</b>	Aerial cable. Quantity 1. Length 2m
<b>Brand Name:</b>	Belkin
<b>Model Name or Number:</b>	Not marked or stated
<b>Serial Number:</b>	Not marked or stated

<b>Description:</b>	Freeview HD Set Top Box
<b>Brand Name:</b>	Technika
<b>Model Name or Number:</b>	STBHDIS2010
<b>Serial Number:</b>	GRTB58073912047

<b>Description:</b>	USB cable type A male to type A male. Quantity 1. Length 1.5m
<b>Brand Name:</b>	Not marked or stated
<b>Model Name or Number:</b>	Not marked or stated
<b>Serial Number:</b>	Not marked or stated

<b>Description:</b>	USB Hub
<b>Brand Name:</b>	Belkin
<b>Model Name or Number:</b>	Not marked or stated
<b>Serial Number:</b>	Not marked or stated

**Support Equipment (continued)**

<b>Description:</b>	USB extension lead. Quantity 1. Length 2m
<b>Brand Name:</b>	Not marked or stated
<b>Model Name or Number:</b>	Not marked or stated
<b>Serial Number:</b>	Not marked or stated

<b>Description:</b>	22" HD Television
<b>Brand Name:</b>	LOGIK
<b>Model Name or Number:</b>	22FE12A
<b>Serial Number:</b>	1309020661

## **4. Operation and Monitoring of the EUT during Testing**

### **4.1. Operating Modes**

The EUT was tested in the following operating mode(s):

- Continuously transmitting with a modulated carrier at maximum power on the bottom, middle and top channels as required using the supported data rates/modulation types.

### **4.2. Configuration and Peripherals**

The EUT was tested in the following configuration(s):

- Controlled using *MT7662U\_QA\_tool\_V1.0.3.0* bespoke application supplied by the customer on a UL laptop PC. The application was used to enable a continuous transmission mode and to select the test channels, data rates and modulation schemes as required.
- All supported modes and channel widths were initially investigated on one channel. The modes that produced the highest power, narrowest bandwidth and widest bandwidth for all bands were:
  - Highest power
    - 802.11b – DQPSK / 2 Mbps
    - 802.11g SISO – BPSK / 6 Mbps
    - 802.11g CDD1 – BPSK / 6 Mbps
    - 802.11n HT20 SISO – 16QAM / 39 Mbps / MCS4
    - 802.11n HT20 CDD1 – BPSK / 6.5 Mbps / MCS0
    - 802.11n HT40 SISO – 16QAM / 81 Mbps / MCS4
    - 802.11n HT40 CDD1 – BPSK / 13.5 Mbps / MCS0
  - Narrowest bandwidth
    - 802.11b – DQPSK / 2 Mbps
    - 802.11g SISO – BPSK / 6 Mbps
    - 802.11n HT20 SISO – QPSK / 13 Mbps / MCS1
    - 802.11n HT40 SISO – BPSK / 13.5 Mbps / MCS0
  - Widest bandwidth
    - 802.11b – DQPSK / 2 Mbps
    - 802.11g SISO – BPSK / 6 Mbps
    - 802.11g CDD1 – BPSK / 6 Mbps
    - 802.11n HT20 SISO – QPSK / 13 Mbps / MCS1
    - 802.11n HT20 CDD1 – BPSK / 6.5 Mbps / MCS0
    - 802.11n HT40 SISO – BPSK / 13.5 Mbps / MCS0
    - 802.11n HT40 CDD1 – BPSK / 13.5 Mbps / MCS0
- For all conducted measurements the EUT, being the module, was connected to a DC power supply and powered by 3.3 VDC. The module consisted of a pcb fitted with an 8-pin in-line connector. The customer supplied a bespoke USB adaptor assembly that allowed a USB-B socket to interface to the 8-pin connector. Additionally the USB adaptor was fitted with two flying leads that connected to an external laboratory power supply to provide DC voltage to the EUT.

### **Configuration and Peripherals (continued)**

- For all radiated measurements the EUT, being the TV, was connected to 120 or 240 VAC 60 Hz depending on the test case. The customer had fitted a USB cable to the module that was inside the TV. This was used to place the TV into test mode as required.
- The EUT has two separate antennas which correspond to two separate antenna ports. DAC 0 and DAC 1 correspond to antenna 1 and antenna 2 respectively.
- For 802.11b the EUT transmits only from antenna 1, therefore conducted measurements were performed on DAC0 only.
- For 802.11g and 802.11n the EUT can transmit from both antennas, therefore conducted measurements were performed on both ports.
- The customer declared the power settings which are stated in section 4.3 of this test report.
- Radiated emissions were performed with the EUT transmitting with a data rate of 802.11g / 6 Mbps on Antenna 1 as it produced the worst conducted output power and highest spectral density level and was therefore deemed worst case.
- The module did not have an internal integral antenna but was fitted with a UFL antenna connector. All radiated measurements were performed with the module placed in its end host device, the 55" television.
- Radiated measurements: In order to operate the EUT the TV needed to be enabled. This was done by turning on the TV and pairing it with T30 remote control with the external BTLE box which was connected to the TV. The external BTLE box has 0.83m cable with a USB type A male connector. Once the TV was enabled, the EUT could be controlled using the MT7662U application.
- Once the TV was turned on and the EUT was in transmit mode the T30 remote control and external BTLE box were removed from the chamber.
- For all radiated tests the support equipment was used to terminate all active ports.
- The conducted sample with MAC Address 542AA22F8F19 was used for minimum 6 dB bandwidth, duty cycle, maximum output power and power spectral density tests.
- The radiated sample with serial number 92777 was used for all other tests.

### **4.3. Power Settings**

The manufacturer's declared power settings stated in the table below were used for both SISO and MIMO measurements:

Mode	Power Setting		
	Bottom Channel	Middle Channel	Top Channel
802.11b SISO – 2 Mbps	12	14	14
802.11g SISO – 6 Mbps	14	16	16
802.11g CDD1 – 6 Mbps	0E	10	10
802.11n HT20 SISO – 13 Mbps / MCS1	14	16	16
802.11n HT20 SISO – 39 Mbps / MCS4	14	1A	16
802.11n HT20 CDD1 – 6.5 Mbps / MCS0	0E	10	10
802.11n HT40 SISO – 13.5 Mbps / MCS0	16	16	13
802.11n HT40 SISO – 81 Mbps / MCS4	1A	1A	18
802.11n HT40 CDD1 – 13.5 Mbps / MCS0	10	10	10

## **5. Measurements, Examinations and Derived Results**

### **5.1. General Comments**

Measurement uncertainties are evaluated in accordance with current best practice. Our reported expanded uncertainties are based on standard uncertainties, which are multiplied by an appropriate coverage factor to provide a statistical confidence level of approximately 95%. Please refer to *Section 6. Measurement Uncertainty* for details.

In accordance with UKAS requirements all the measurement equipment is on a calibration schedule. All equipment was within the calibration period on the date of testing.

## **5.2. Test Results**

### **5.2.1. Transmitter AC Conducted Spurious Emissions**

#### **Test Summary:**

<b>Test Engineer:</b>	Andrew Edwards	<b>Test Date:</b>	04 April 2016
<b>Test Sample Serial Number:</b>	92777		

<b>FCC Reference:</b>	Part 15.207
<b>Test Method Used:</b>	ANSI C63.10 Section 6.2 / FCC KDB 174176 and notes below.

#### **Environmental Conditions:**

<b>Temperature (°C):</b>	22
<b>Relative Humidity (%):</b>	40

#### **Note(s):**

1. The EUT was connected to the power supply input which was connected to a 120 VAC 60 Hz single phase supply via a LISN.
2. In accordance with FCC KDB 174176 Q4, the test was repeated with 240 VAC 60 Hz single phase supply as this was within the voltage of the Television power supply.
3. A pulse limiter was fitted between the LISN and the test receiver.
4. Pre-scans were performed on live and neutral for all technologies that the EUT supported. As the emissions were the same for all technologies, final measurements were performed with the mode that produced the highest EIRP. The EUT was set to 5 GHz WLAN mode, transmitting with a data rate of 802.11a / 6 Mbps / SISO / DAC0 at 5200 MHz.
5. Pre-scans were performed and markers placed on the highest live and neutral measured levels. Final measurements were performed on the marker frequencies and the results entered into the tables below.
6. In accordance with ANSI C63.10 Section 6.2.5, the six highest emissions were recorded in the tables below.
7. In the block diagram below, the number in brackets relates to the quantity of cables which were connected between the TV and the support equipment.



**Transmitter AC Conducted Spurious Emissions (continued)**

**Test setup:**

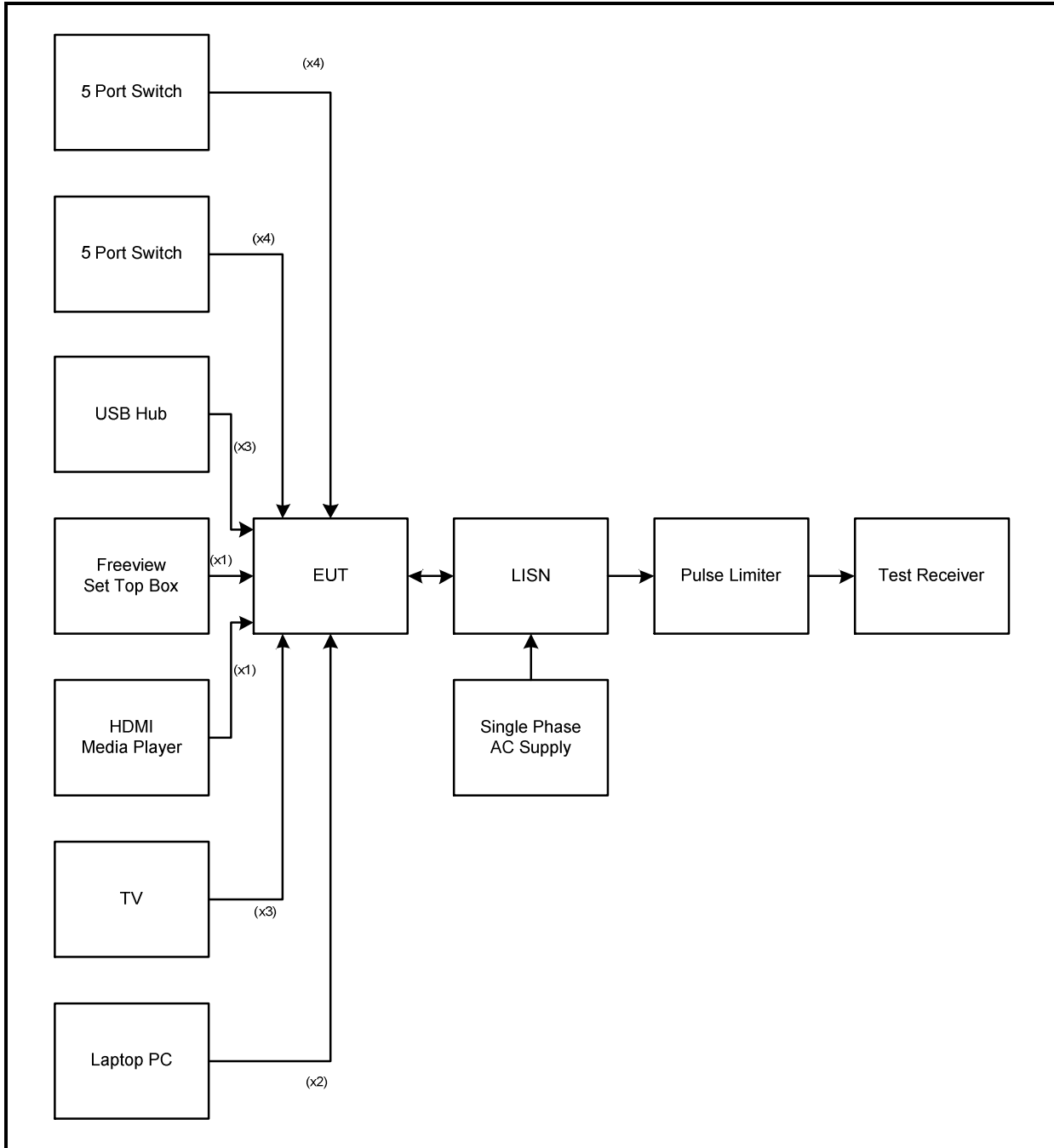

**Transmitter AC Conducted Spurious Emissions (continued)****Results: Live / Quasi Peak / 120 VAC 60 Hz**

Frequency (MHz)	Line	Level (dB $\mu$ V)	Limit (dB $\mu$ V)	Margin (dB)	Result
1.199	Live	37.7	56.0	18.3	Complied
1.901	Live	37.6	56.0	18.4	Complied
2.045	Live	38.3	56.0	17.7	Complied
3.732	Live	37.5	56.0	18.5	Complied
7.251	Live	42.7	60.0	17.3	Complied
7.391	Live	42.6	60.0	17.4	Complied

**Results: Live / Average / 120 VAC 60 Hz**

Frequency (MHz)	Line	Level (dB $\mu$ V)	Limit (dB $\mu$ V)	Margin (dB)	Result
0.213	Live	43.4	53.1	9.7	Complied
0.915	Live	42.3	46.0	3.7	Complied
1.199	Live	36.3	46.0	9.7	Complied
1.338	Live	37.0	46.0	9.0	Complied
1.761	Live	36.5	46.0	9.5	Complied
1.901	Live	36.6	46.0	9.4	Complied

**Results: Neutral / Quasi Peak / 120 VAC 60 Hz**

Frequency (MHz)	Line	Level (dB $\mu$ V)	Limit (dB $\mu$ V)	Margin (dB)	Result
0.258	Neutral	44.8	61.5	16.7	Complied
0.776	Neutral	39.5	56.0	16.5	Complied
0.915	Neutral	39.2	56.0	16.8	Complied
1.338	Neutral	38.8	56.0	17.2	Complied
2.045	Neutral	39.2	56.0	16.8	Complied
5.982	Neutral	43.4	60.0	16.6	Complied

**Results: Neutral / Average / 120 VAC 60 Hz**

Frequency (MHz)	Line	Level (dB $\mu$ V)	Limit (dB $\mu$ V)	Margin (dB)	Result
0.353	Neutral	41.5	48.9	7.4	Complied
0.492	Neutral	40.2	46.1	5.9	Complied
0.776	Neutral	38.9	46.0	7.1	Complied
0.915	Neutral	39.0	46.0	7.0	Complied
1.055	Neutral	38.2	46.0	7.8	Complied
1.338	Neutral	38.3	46.0	7.7	Complied

**Transmitter AC Conducted Spurious Emissions (continued)**

**Results: 120 VAC 60 Hz**

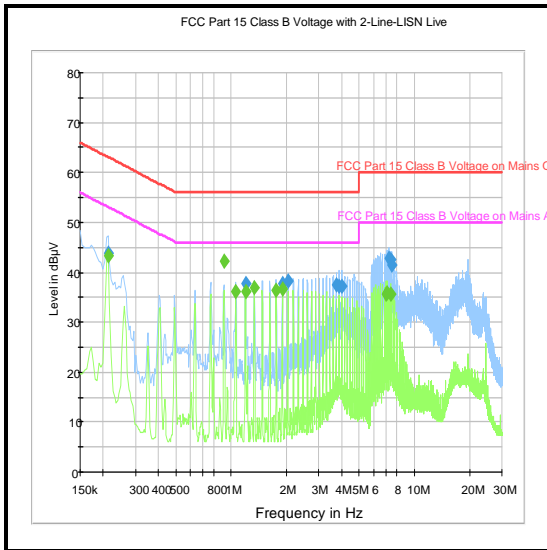

**Live**

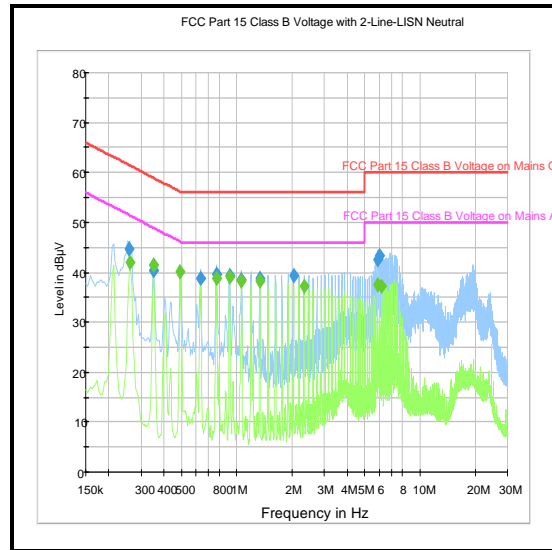

**Neutral**

*Note: These plots are pre-scans and for indication purposes only. For final measurements, see accompanying tables.*

**Transmitter AC Conducted Spurious Emissions (continued)****Results: Live / Quasi Peak / 240 VAC 60 Hz**

Frequency (MHz)	Line	Level (dB $\mu$ V)	Limit (dB $\mu$ V)	Margin (dB)	Result
0.371	Live	45.6	58.5	12.9	Complied
0.631	Live	40.3	56.0	15.7	Complied
0.776	Live	41.0	56.0	15.0	Complied
0.915	Live	41.1	56.0	14.9	Complied
1.055	Live	40.4	56.0	15.6	Complied
1.338	Live	40.3	56.0	15.7	Complied

**Results: Live / Average / 240 VAC 60 Hz**

Frequency (MHz)	Line	Level (dB $\mu$ V)	Limit (dB $\mu$ V)	Margin (dB)	Result
0.371	Live	42.2	48.5	6.3	Complied
0.915	Live	40.8	46.0	5.2	Complied
1.055	Live	39.5	46.0	6.5	Complied
1.338	Live	38.9	46.0	7.1	Complied
1.478	Live	38.8	46.0	7.2	Complied
1.901	Live	37.8	46.0	8.2	Complied

**Results: Neutral / Quasi Peak / 240 VAC 60 Hz**

Frequency (MHz)	Line	Level (dB $\mu$ V)	Limit (dB $\mu$ V)	Margin (dB)	Result
0.263	Neutral	46.5	61.4	14.9	Complied
0.492	Neutral	43.5	56.1	12.6	Complied
0.632	Neutral	42.3	56.0	13.7	Complied
0.776	Neutral	42.6	56.0	13.4	Complied
1.055	Neutral	41.3	56.0	14.7	Complied
1.199	Neutral	41.0	56.0	15.0	Complied

**Results: Neutral / Average / 240 VAC 60 Hz**

Frequency (MHz)	Line	Level (dB $\mu$ V)	Limit (dB $\mu$ V)	Margin (dB)	Result
0.353	Neutral	42.6	48.9	6.3	Complied
0.492	Neutral	41.7	46.1	4.4	Complied
0.776	Neutral	40.9	46.0	5.1	Complied
0.915	Neutral	40.9	46.0	5.1	Complied
1.055	Neutral	39.9	46.0	6.1	Complied
1.338	Neutral	39.6	46.0	6.4	Complied

**Transmitter AC Conducted Spurious Emissions (continued)**

**Results: 240 VAC 60 Hz**

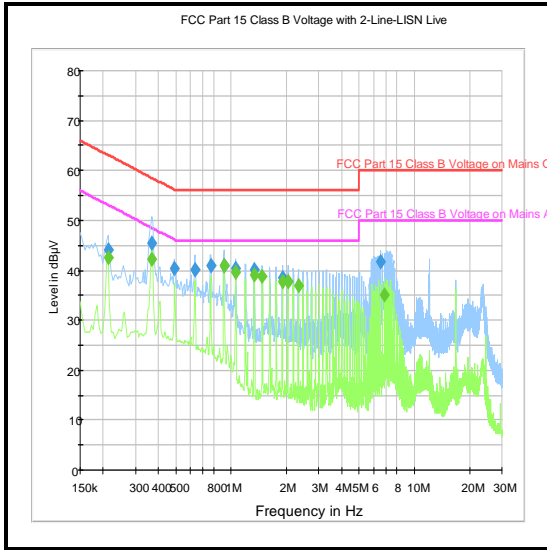

**Live**

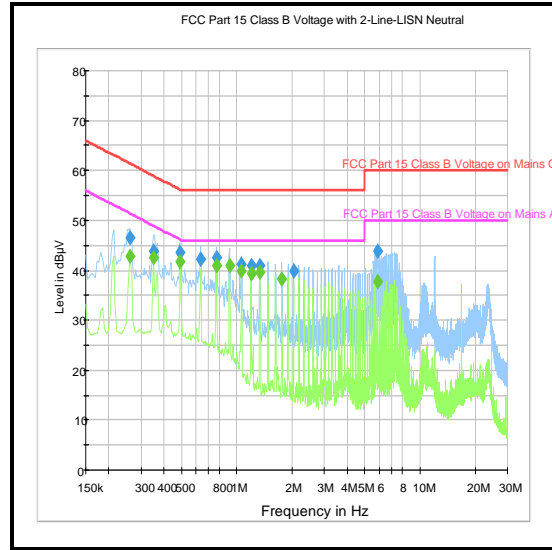

**Neutral**

Note: These plots are pre-scans and for indication purposes only. For final measurements, see accompanying tables.

**Test Equipment Used:**

Asset No.	Instrument	Manufacturer	Type No.	Serial No.	Date Calibration Due	Cal. Interval (Months)
M1624	Thermohygrometer	JM Handelpunkt	30.5015.10	Not stated	11 Jan 2017	12
M1263	Test Receiver	Rohde & Schwarz	ESIB7	100265	16 Oct 2016	12
A067	LISN	Rohde & Schwarz	ESH3-Z5	890603/002	27 Aug 2016	12
A1830	Pulse Limiter	Rohde & Schwarz	ESH3-Z2	100668	08 Mar 2017	12
M1251	Digital Multimeter	Fluke	175	89170179	26 May 2016	12
S0539	Variable AC Power Supply	Kikusui	PCR 1000L	13010170	Calibrated before use	-

**5.2.2. Transmitter Minimum 6 dB Bandwidth****Test Summary:**

<b>Test Engineer:</b>	Nick Steele	<b>Test Date:</b>	16 November 2015
<b>Test Sample MAC address:</b>	542AA22F8F19		

<b>FCC Reference:</b>	Part 15.247(a)(2)
<b>Test Method Used:</b>	FCC KDB 558074 Section 8.1

**Environmental Conditions:**

<b>Temperature (°C):</b>	25
<b>Relative Humidity (%):</b>	40

**Note(s):**

1. All configurations supported by the EUT were investigated on one channel in accordance with KDB 558074 Section 8.1 Option 1 measurement procedure. The test receiver resolution bandwidth was set to 100 kHz and video bandwidth 300 kHz. A peak detector was used, sweep time was set to auto and the trace mode was Max Hold. The span was set to 30 MHz for 20 MHz channel bandwidth and 60 MHz for 40 MHz channel bandwidth. The DTS bandwidth was measured at 6 dB down from the peak of the signal. The data rates that produced the narrowest bandwidth and therefore deemed worst case were:

- 802.11b – DQPSK / 2 Mbps
- 802.11g SISO – BPSK / 6 Mbps
- 802.11n HT20 SISO – QPSK / 13 Mbps / MCS1
- 802.11n HT40 SISO – BPSK / 13.5 Mbps / MCS0

Final measurements were performed using the above configurations on the bottom, middle and top channels in accordance with KDB 558074 Section 8.1 Option 1 measurement procedure.

2. Final measurements were performed on SISO modes only, on Port DAC 0, as the bandwidth does not change dependant on chains used.
3. Plots for all data rates are archived on the Company server and available for inspection upon request.
4. The test receiver was connected to the RF port on the EUT using suitable attenuation and RF cable.

**Transmitter Minimum 6 dB Bandwidth (continued)**

**Test setup:**

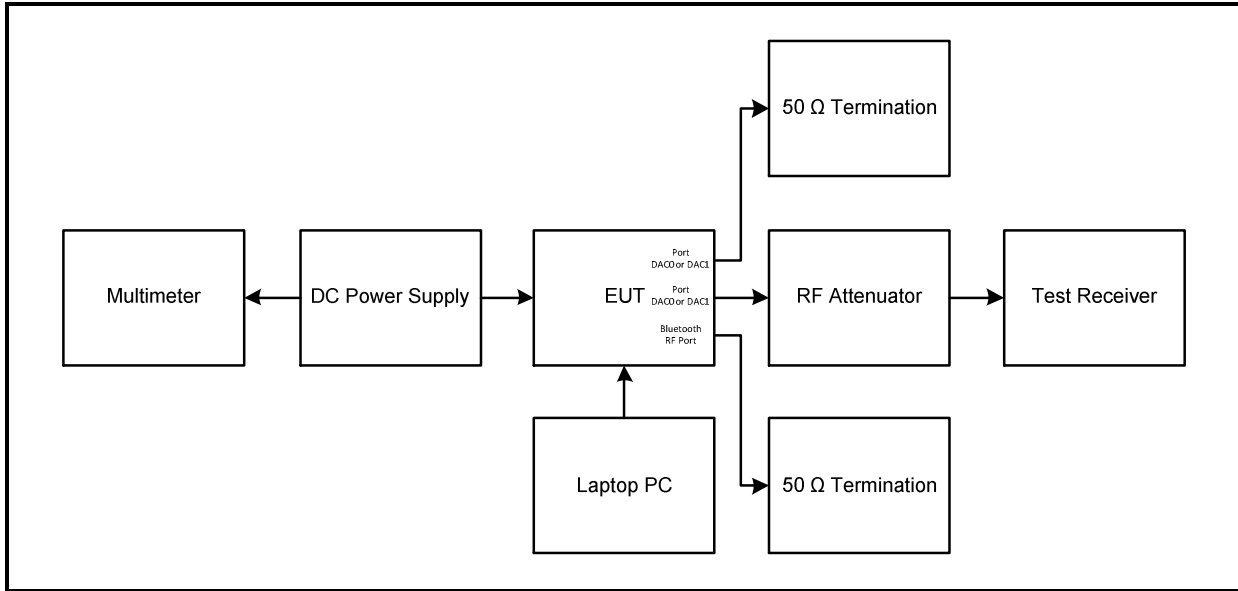

**Transmitter Minimum 6 dB Bandwidth (continued)**

**Results: 802.11b / 20 MHz / DQPSK / 2 Mbps**

Channel	6 dB Bandwidth (kHz)	Limit (kHz)	Margin (kHz)	Result
Bottom	10144.231	≥500	9644.231	Complied
Middle	10144.231	≥500	9644.231	Complied
Top	10144.231	≥500	9644.231	Complied

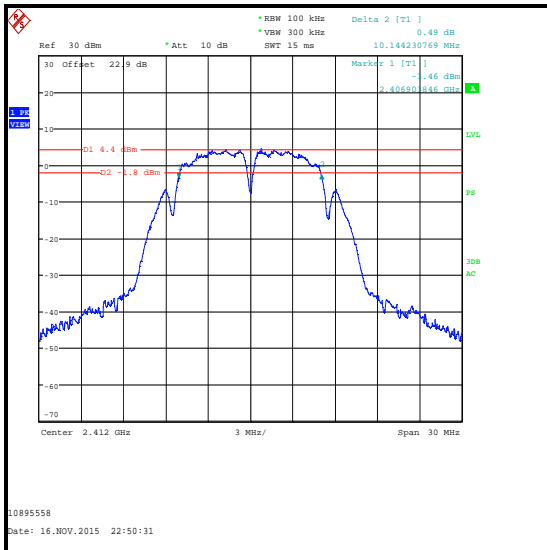

**Bottom Channel**

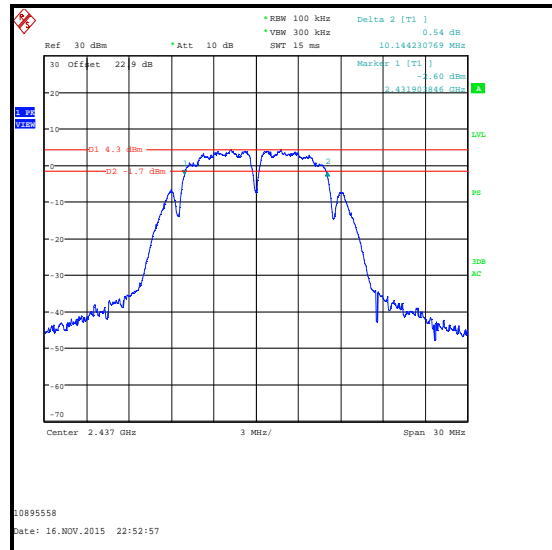

**Middle Channel**



**Top Channel**



**Transmitter Minimum 6 dB Bandwidth (continued)**

**Results: 802.11g / 20 MHz / SISO / BPSK / 6 Mbps**

Channel	6 dB Bandwidth (kHz)	Limit (kHz)	Margin (kHz)	Result
Bottom	16394.231	≥500	15894.231	Complied
Middle	16394.231	≥500	15894.231	Complied
Top	16346.154	≥500	15846.154	Complied

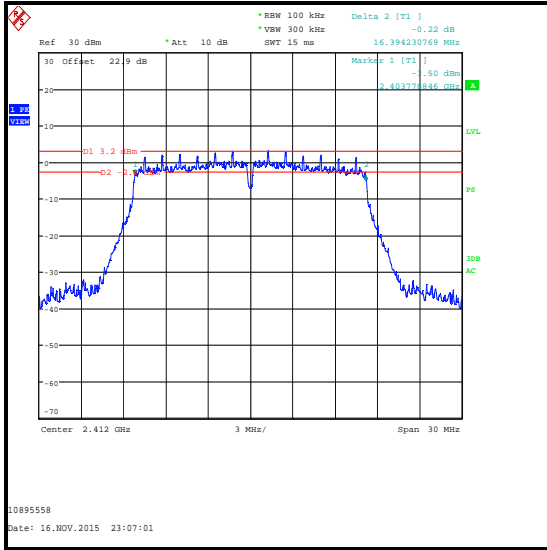

**Bottom Channel**

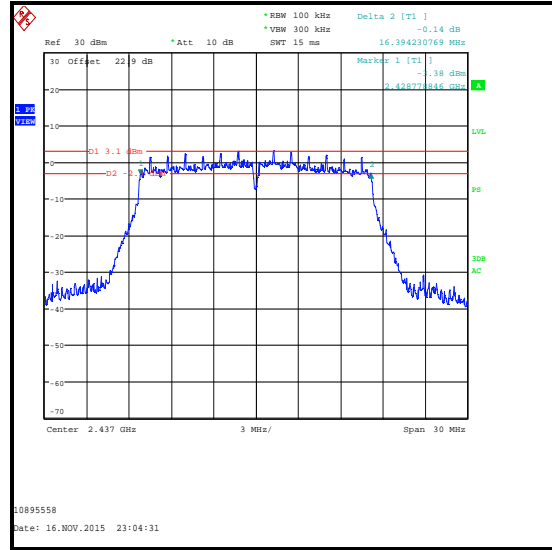

**Middle Channel**

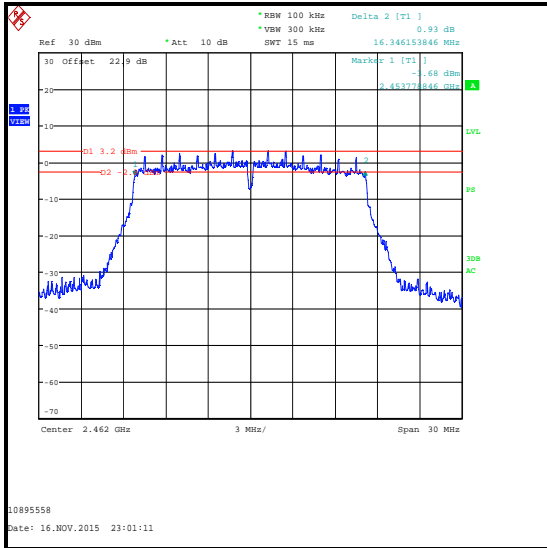

**Top Channel**

**Transmitter Minimum 6 dB Bandwidth (continued)**

**Results: 802.11n / 20 MHz / SISO / QPSK / MCS1**

Channel	6 dB Bandwidth (kHz)	Limit (kHz)	Margin (kHz)	Result
Bottom	17355.769	≥500	16855.769	Complied
Middle	16971.154	≥500	16471.154	Complied
Top	17115.385	≥500	16615.385	Complied

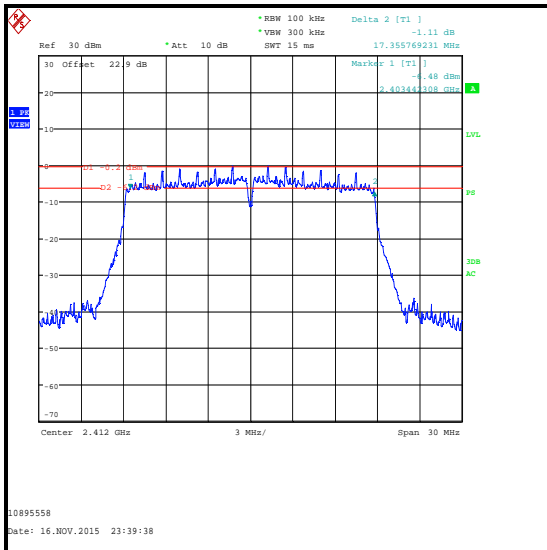

**Bottom Channel**

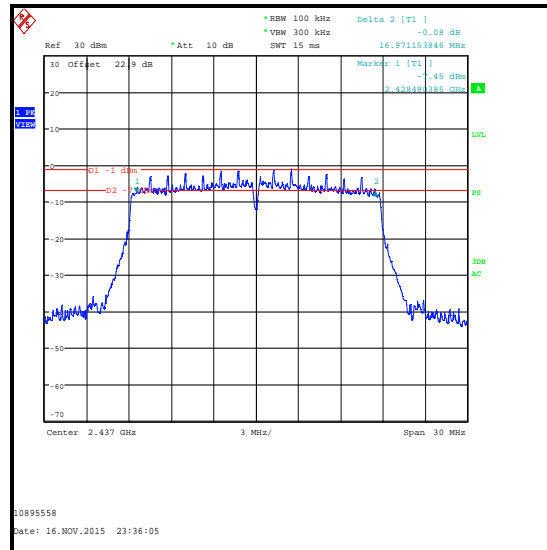

**Middle Channel**

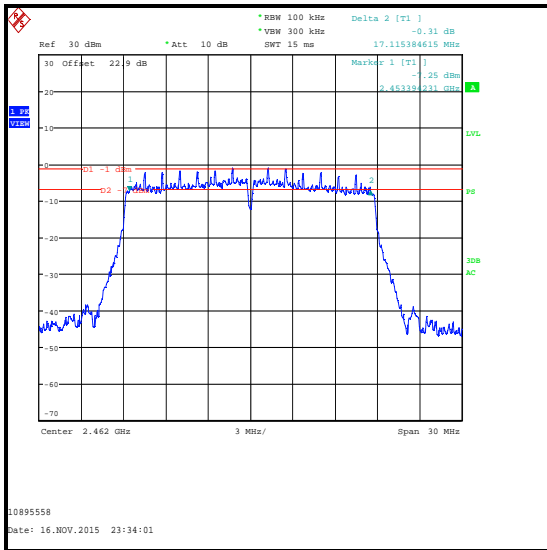

**Top Channel**

**Transmitter Minimum 6 dB Bandwidth (continued)**

**Results: 802.11n / 40 MHz / SISO / BPSK / MCS 0**

Channel	6 dB Bandwidth (kHz)	Limit (kHz)	Margin (kHz)	Result
Bottom	35673.077	≥500	35173.077	Complied
Top	35673.077	≥500	35173.077	Complied

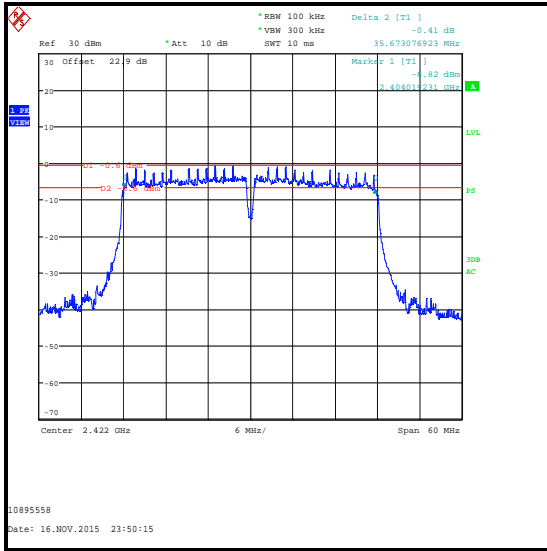

Bottom Channel

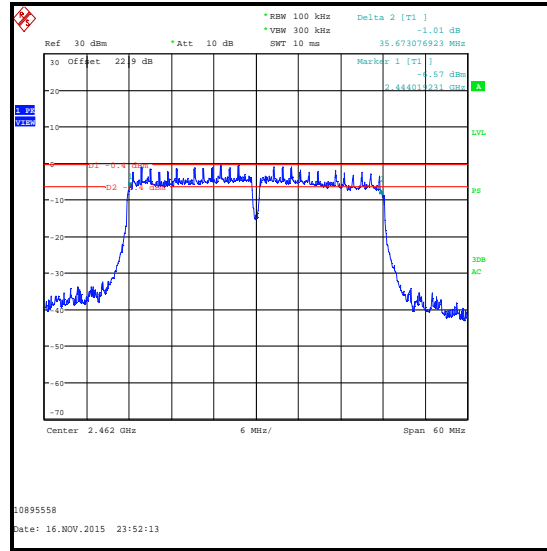

Top Channel

**Test Equipment Used:**

Asset No.	Instrument	Manufacturer	Type No.	Serial No.	Date Calibration Due	Cal. Interval (Months)
M1785	Thermohygrometer	JM Handelspunkt	30.5015.13	None stated	23 Apr 2016	12
M1886	Test Receiver	Rohde & Schwarz	ESU26	100554	21 May 2016	12
A2520	Attenuator	AtlanTecRF	AN18-20	832797#1	Calibrated before use	-
S0558	DC Power Supply	TTI	EL303R	395825	Calibrated before use	-
M1229	Multimeter	Fluke	179	87640015	23 Apr 2016	12
G0607	Signal Generator	Rohde & Schwarz	SMU200A	100943	18 Jul 2016	36
M199	Power Meter	Rohde & Schwarz	NRVS	827023/075	08 Apr 2016	24
M1267	Power Sensor	Rohde & Schwarz	NRV-Z52	100155	23 Apr 2016	24

**5.2.3. Transmitter Duty Cycle**

**Test Summary:**

<b>Test Engineer:</b>	Nick Steele	<b>Test Dates:</b>	09 November 2015 to 12 November 2015
<b>Test Sample MAC address:</b>	542AA22F8F19		

<b>FCC Reference:</b>	Part 15.35(c)
<b>Test Method Used:</b>	FCC KDB 558074 Section 6.0

**Environmental Conditions:**

<b>Temperature (°C):</b>	23 to 25
<b>Relative Humidity (%):</b>	41 to 45

**Note(s):**

- In order to assist with the determination of the average level of fundamental and spurious emissions field strength, measurements were made of duty cycle to determine the transmission duration and the silent period time of the transmitter. The transmitter duty cycle was measured using a spectrum analyser in the time domain and calculated by using the following calculation:

$$10 \log (1 / (\text{On Time} / [\text{Period or } 100 \text{ ms whichever is the lesser}])).$$

$$802.11b / 20 \text{ MHz} / 2 \text{ Mbps} / \text{duty cycle } 10 \log (1 / (4.449/4.652)) = 0.2 \text{ dB}$$

$$802.11g / 20 \text{ MHz} / 6 \text{ Mbps} / \text{SISO} / \text{duty cycle } 10 \log (1 / (1.445/1.649)) = 0.6 \text{ dB}$$

$$802.11g / 20 \text{ MHz} / 6 \text{ Mbps} / \text{CDD1} / \text{duty cycle } 10 \log (1 / (1.443/1.646)) = 0.6 \text{ dB}$$

$$802.11n / \text{HT20} / \text{MCS4} / \text{SISO} / \text{duty cycle: } 10 \log (1 / (0.257/0.462)) = 2.5 \text{ dB}$$

$$802.11n / \text{HT20} / \text{MCS0} / \text{CDD1} / \text{duty cycle: } 10 \log (1 / (1.354/1.557)) = 0.6 \text{ dB}$$

$$802.11n / \text{HT40} / \text{MCS4} / \text{SISO} / \text{duty cycle: } 10 \log (1 / (0.144/0.348)) = 3.8 \text{ dB}$$

$$802.11n / \text{HT40} / \text{MCS0} / \text{CDD1} / \text{duty cycle: } 10 \log (1 / (0.668/0.873)) = 1.2 \text{ dB}$$

**Test setup:**

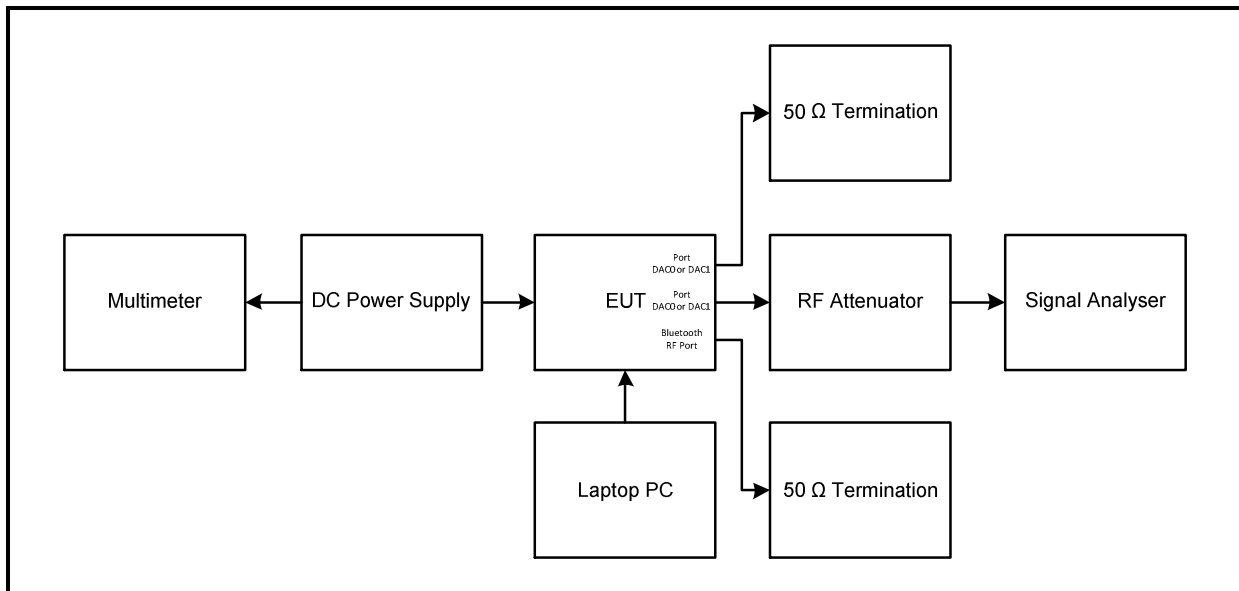

**Transmitter Duty Cycle (continued)**

**Results: 802.11b / HT20 / 2 Mbps / SISO**

Pulse Duration (ms)	Period (ms)	Duty Cycle (dB)
4.449	4.652	0.2

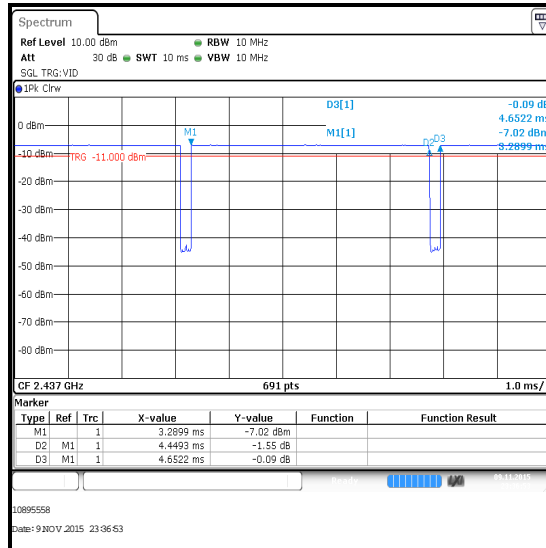

**Results: 802.11g / HT20 / 6 Mbps / SISO**

Pulse Duration (ms)	Period (ms)	Duty Cycle (dB)
1.445	1.649	0.6

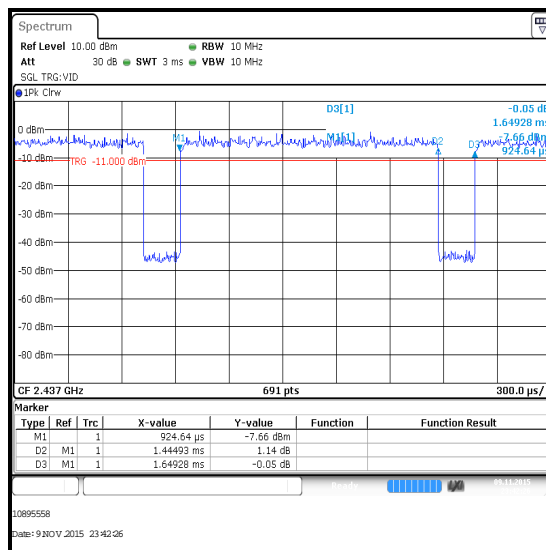

**Transmitter Duty Cycle (continued)**

**Results: 802.11g / HT20 / 6 Mbps / CDD1**

Pulse Duration (ms)	Period (ms)	Duty Cycle (dB)
1.443	1.646	0.6

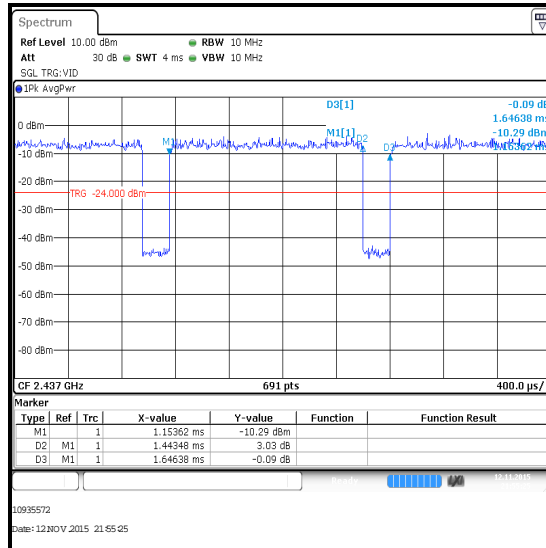

**Results: 802.11n / HT20 / MCS4 / SISO**

Pulse Duration (ms)	Period (ms)	Duty Cycle (dB)
0.257	0.462	2.5

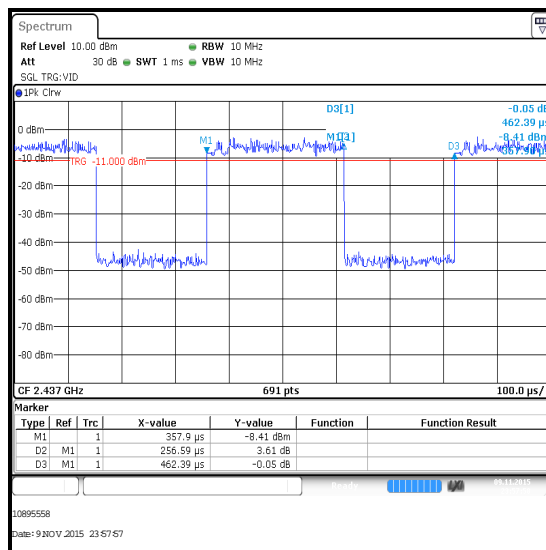

**Transmitter Duty Cycle (continued)**

**Results: 802.11n / HT20 / MCS0 / CDD1**

Pulse Duration (ms)	Period (ms)	Duty Cycle (dB)
1.354	1.557	0.6

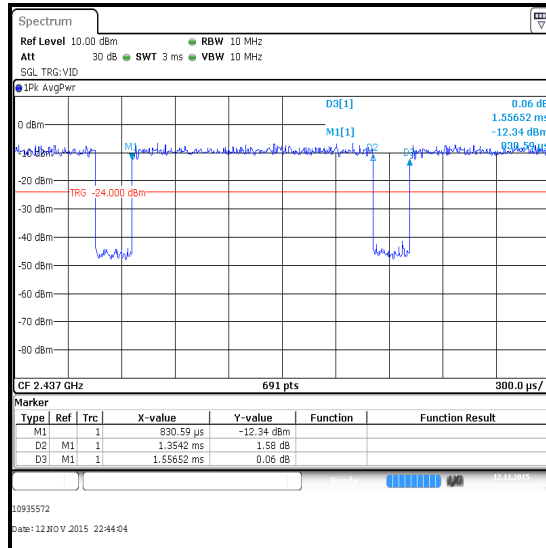

**Results: 802.11n / HT40 / MCS4 / SISO**

Pulse Duration (ms)	Period (ms)	Duty Cycle (dB)
0.144	0.348	3.8

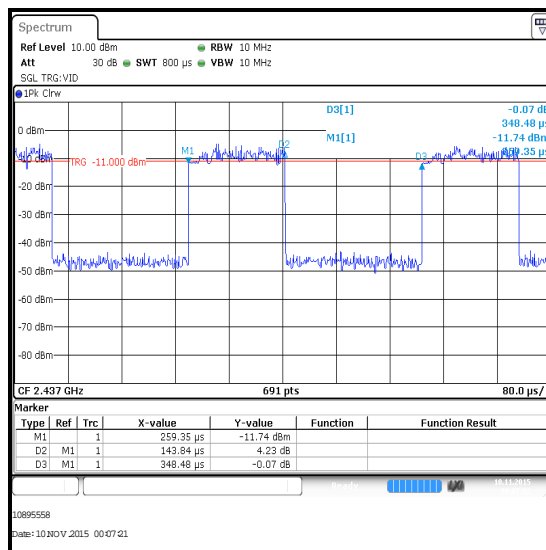

**Transmitter Duty Cycle (continued)**

**Results: 802.11n / HT40 / MCS0 / CDD1**

Pulse Duration (ms)	Period (ms)	Duty Cycle (dB)
0.668	0.873	1.2

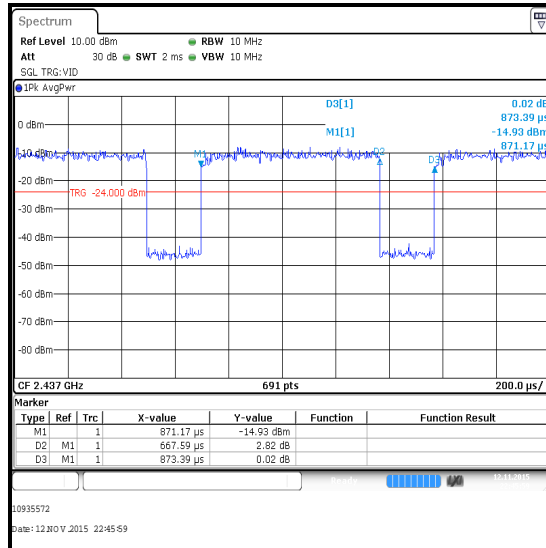

**Test Equipment Used:**

Asset No.	Instrument	Manufacturer	Type No.	Serial No.	Date Calibration Due	Cal. Interval (Months)
M1783	Thermohygrometer	JM Handelpunkt	30.5015.13	Not stated	23 Apr 2016	12
M1883	Signal Analyser	Rohde & Schwarz	FSV30	103084	23 Jul 2016	12
A2520	Attenuator	AtlanTecRF	AN18-20	832797#1	Calibrated before use	-
S0558	DC Power Supply	TTI	EL303R	395825	Calibrated before use	-
M1269	Multimeter	Fluke	179	90250210	26 May 2016	12
G0607	Signal Generator	Rohde & Schwarz	SMU200A	100943	18 Jul 2016	36
M199	Power Meter	Rohde & Schwarz	NRVS	827023/075	08 Apr 2016	24
M1267	Power Sensor	Rohde & Schwarz	NRV-Z52	100155	23 Apr 2016	24



**5.2.4. Transmitter Power Spectral Density****Test Summary:**

<b>Test Engineer:</b>	Andrew Edwards	<b>Test Date:</b>	22 April 2016
<b>Test Sample MAC address:</b>	542AA22F8F19		

<b>FCC Reference:</b>	Part 15.247(e)
<b>Test Method Used:</b>	FCC KDB 558074 Sections 10.5

**Environmental Conditions:**

<b>Temperature (°C):</b>	24
<b>Relative Humidity (%):</b>	30

**Note(s):**

- All supported modes and channel widths were initially investigated on one channel. The modes that produced the highest power were:
  - 802.11b – DQPSK / 2 Mbps
  - 802.11g SISO – BPSK / 6 Mbps
  - 802.11g CDD1 – BPSK / 6 Mbps
  - 802.11n HT20 SISO – 16QAM / 39 Mbps / MCS4
  - 802.11n HT20 CDD1 – BPSK / 6.5 Mbps / MCS0
  - 802.11n HT40 SISO – 16QAM / 81 Mbps / MCS4
  - 802.11n HT40 CDD1 – BPSK / 13.5 Mbps / MCS0
- Final measurements were performed using the above configurations on the bottom, middle and top channels.
- For 802.11b the EUT transmits only from antenna 1, therefore conducted measurements were performed on port DAC 0 as this was found to produce the highest output power in SISO mode and therefore deemed worst case.
- For 802.11g and 802.11n the EUT can transmit from both antennas, therefore conducted measurements were performed on both ports.
- The EUT was transmitting at <98% duty cycle and testing was performed in accordance with KDB 558074 Section 10.5 Method AVGPS-2. The test receiver resolution bandwidth was set to 100 kHz and video bandwidth 300 kHz. An RMS detector was used and sweep time set to auto couple. Trace averaging was employed over 100 traces. The span was set to at least 1.5 times the 99% occupied emission bandwidth. The highest peak of the measured signal was recorded. The calculated duty cycle in section 5.2.3 was added to the measured average power spectral density in order to compute the average power spectral density during the actual transmission time.
- For CDD1 modes, PSD was measured on both ports and then combined using the *measure and sum spectral maxima across the outputs* technique, stated in FCC KDB 662911 D01 Section E)2)b).
- The test receiver was connected to the RF port on the EUT using suitable attenuation and RF cable. An RF level offset was entered on the test receiver to compensate for the loss of the attenuator and RF cable.

**Transmitter Power Spectral Density (continued)**

**Test setup:**

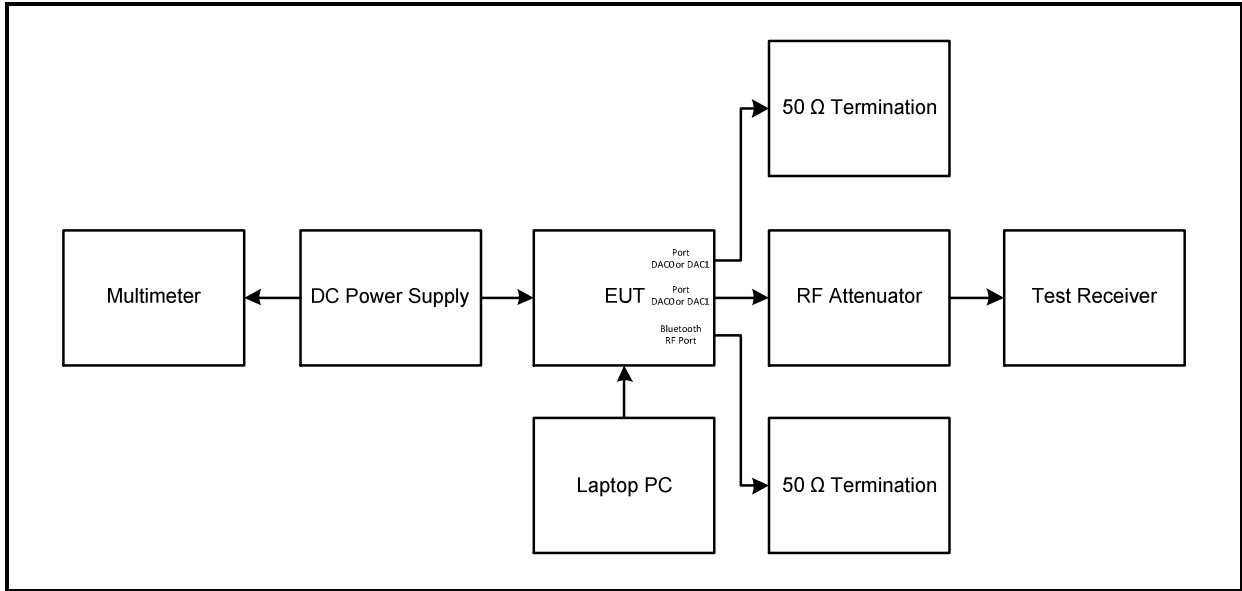

**Transmitter Power Spectral Density (continued)**

**Results: 802.11b / 20 MHz / DQPSK / 2 Mbps / DAC 0**

Channel	Output Power (dBm/3 kHz)	Duty Cycle Correction (dB)	Corrected Output Power (dBm/3 kHz)	Limit (dBm/3 kHz)	Margin (dB)	Result
Bottom	-6.6	0.2	-6.4	8.0	14.4	Complied
Middle	-6.0	0.2	-5.8	8.0	13.8	Complied
Top	-6.1	0.2	-5.9	8.0	13.9	Complied



**Bottom Channel / DAC 0**

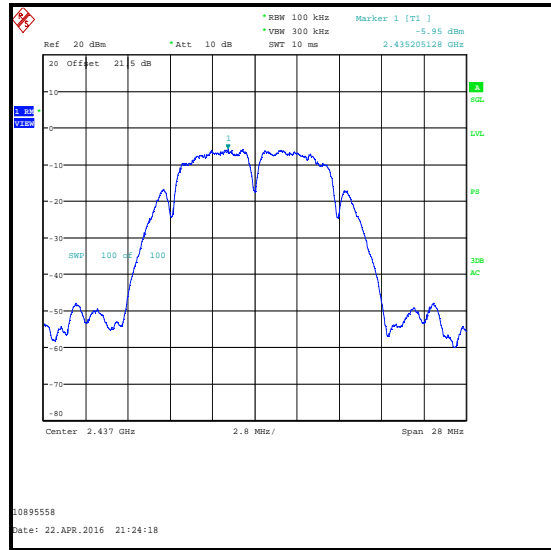

**Middle Channel / DAC 0**



**Top Channel / DAC 0**

**Transmitter Power Spectral Density (continued)**

**Results: 802.11g / 20 MHz / SISO / BPSK / 6 Mbps / DAC 0**

Channel	Output Power (dBm/3 kHz)	Duty Cycle Correction (dB)	Corrected Output Power (dBm/3 kHz)	Limit (dBm/3 kHz)	Margin (dB)	Result
Bottom	-7.3	0.6	-6.7	8.0	14.7	Complied
Middle	-6.6	0.6	-6.0	8.0	14.0	Complied
Top	-6.5	0.6	-5.9	8.0	13.9	Complied



**Bottom Channel / DAC 0**



**Middle Channel / DAC 0**



**Top Channel / DAC 0**

**Transmitter Power Spectral Density (continued)****Results: 802.11g / 20 MHz / CDD1 / BPSK / 6Mbps**

Channel	DAC 0			DAC 1		
	PSD (dBm / 3 kHz)	Duty Cycle Correction (dB)	Corrected PSD (dBm / 3 kHz)	PSD (dBm / 3 kHz)	Duty Cycle Correction (dB)	Corrected PSD (dBm / 3 kHz)
Bottom	-10.6	0.6	-10.0	-12.9	0.6	-12.3
Middle	-9.8	0.6	-9.2	-9.9	0.6	-9.3
Top	-9.5	0.6	-8.9	-12.6	0.6	-12.0

Channel	Corrected PSD at DAC 0 (dBm / 3 kHz)	Corrected PSD at DAC 1 (dBm / 3 kHz)	Combined PSD (dBm / 3 kHz)	PSD Limit (dBm / 3 kHz)	Margin (dB)	Result
Bottom	-10.0	-12.3	-8.0	8.0	16.0	Complied
Middle	-9.2	-9.3	-6.2	8.0	14.2	Complied
Top	-8.9	-12.0	-7.2	8.0	15.2	Complied

**Transmitter Power Spectral Density (continued)**

**Results: 802.11g / 20 MHz / CDD1 / BPSK / 6Mbps / DAC 0**

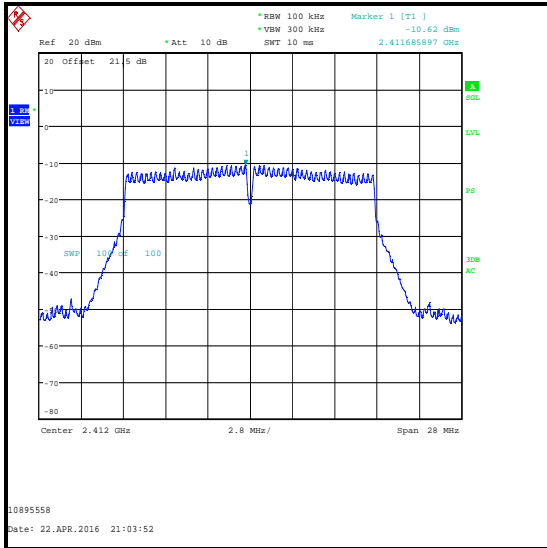

**Bottom Channel / DAC 0**

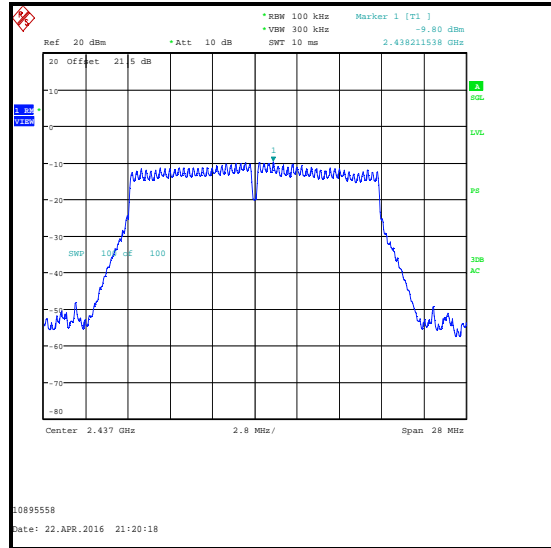

**Middle Channel / DAC 0**

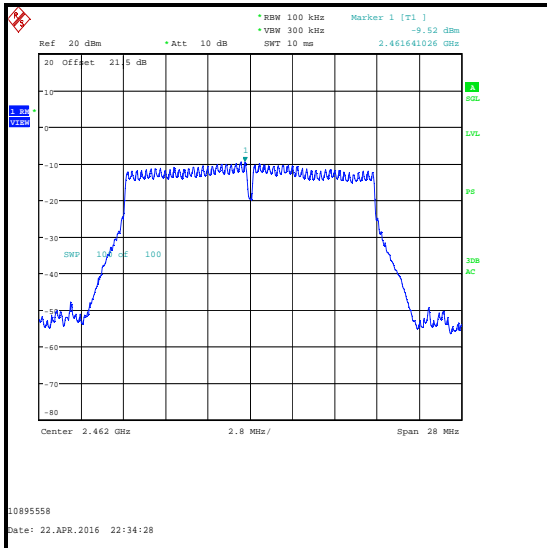

**Top Channel / DAC 0**

**Transmitter Power Spectral Density (continued)**

**Results: 802.11g / 20 MHz / CDD1 / BPSK / 6Mbps / DAC 1**

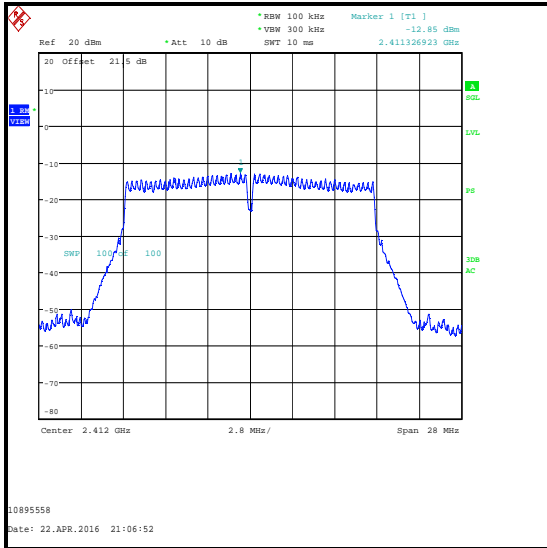

**Bottom Channel / DAC 1**

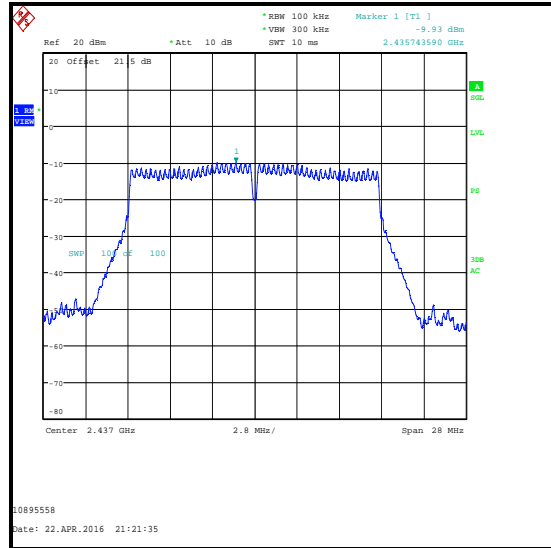

**Middle Channel / DAC 1**

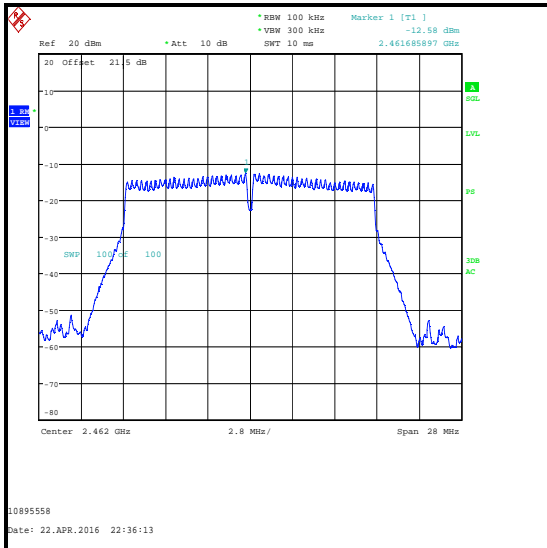

**Top Channel / DAC 1**

**Transmitter Power Spectral Density (continued)**

**Results: 802.11n / HT20 / SISO / 16QAM / MCS4 / DAC 0**

Channel	Output Power (dBm/3 kHz)	Duty Cycle Correction (dB)	Corrected Output Power (dBm/3 kHz)	Limit (dBm/3kHz)	Margin (dB)	Result
Bottom	-11.9	2.5	-9.4	8.0	17.4	Complied
Middle	-8.9	2.5	-6.4	8.0	14.4	Complied
Top	-10.5	2.5	-8.0	8.0	16.0	Complied

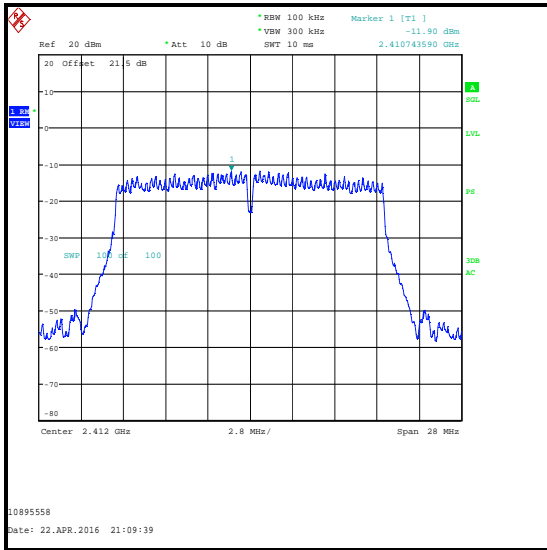

**Bottom Channel / DAC 0**

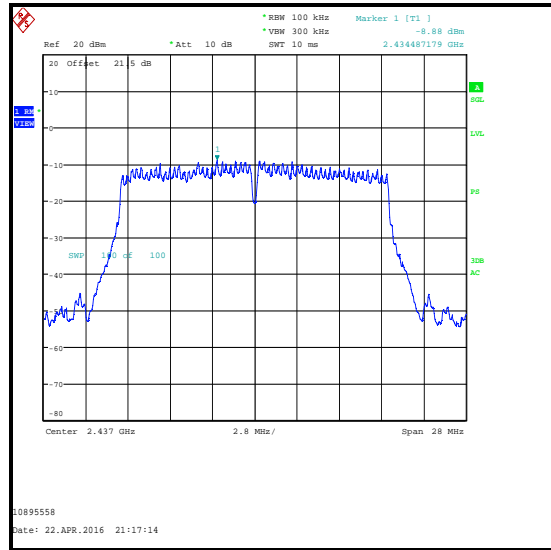

**Middle Channel / DAC 0**

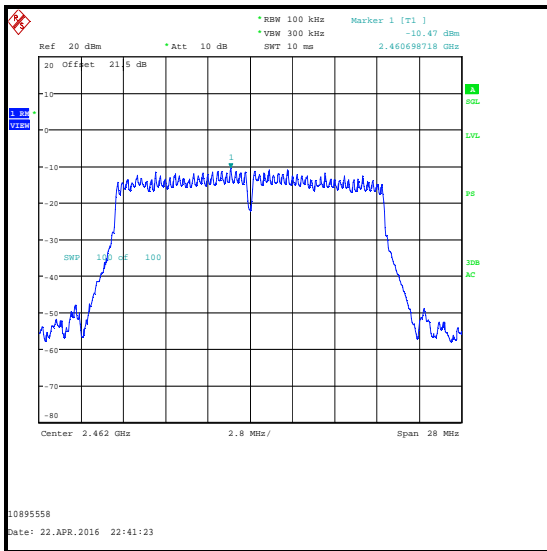

**Top Channel / DAC 0**



**Transmitter Power Spectral Density (continued)****Results: 802.11n / HT20 / CDD1 / BPSK / MCS0**

Channel	DAC 0			DAC 1		
	PSD (dBm / 3 kHz)	Duty Cycle Correction (dB)	Corrected PSD (dBm / 3 kHz)	PSD (dBm / 3 kHz)	Duty Cycle Correction (dB)	Corrected PSD (dBm / 3 kHz)
Bottom	-11.2	0.6	-10.6	-14.1	0.6	-13.5
Middle	-10.7	0.6	-10.1	-14.2	0.6	-13.6
Top	-10.6	0.6	-10.0	-13.7	0.6	-13.1

Channel	Corrected PSD at DAC 0 (dBm / 3 kHz)	Corrected PSD at DAC 1 (dBm / 3 kHz)	Combined PSD (dBm / 3 kHz)	PSD Limit (dBm / 3 kHz)	Margin (dB)	Result
Bottom	-10.6	-13.5	-8.8	8.0	16.8	Complied
Middle	-10.1	-13.6	-8.5	8.0	16.5	Complied
Top	-10.0	-13.1	-8.3	8.0	16.3	Complied

**Transmitter Power Spectral Density (continued)**

**Results: 802.11n / HT20 / CDD1 / BPSK / MCS 0 / DAC 0**

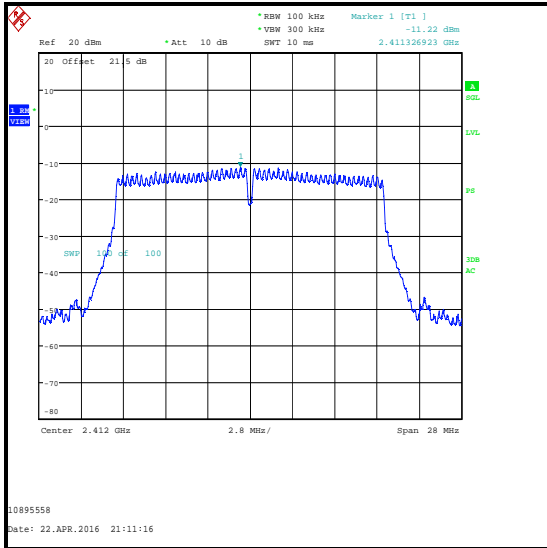

**Bottom Channel / DAC 0**

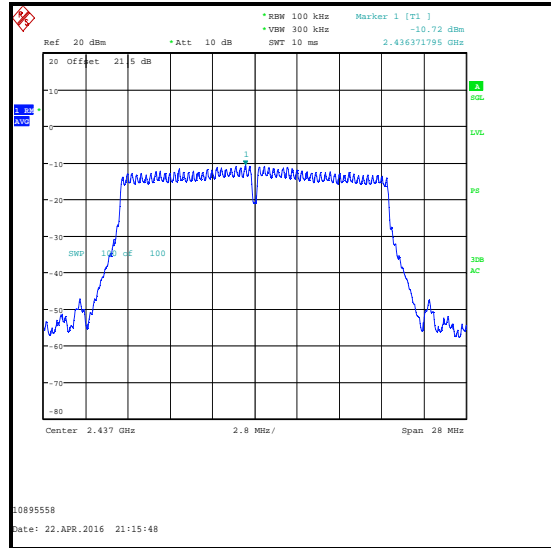

**Middle Channel / DAC 0**

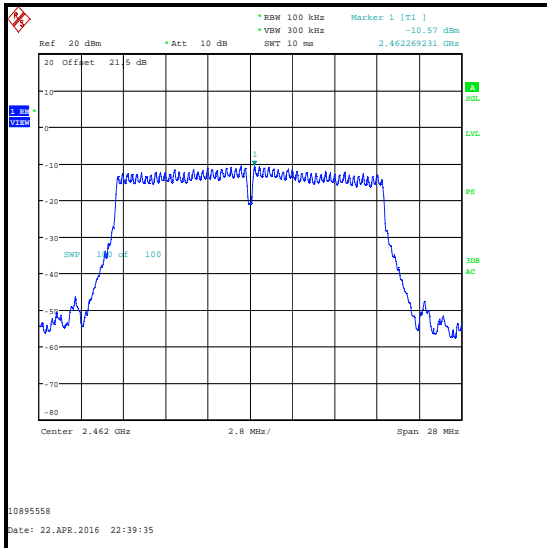

**Top Channel / DAC 0**

**Transmitter Power Spectral Density (continued)**

**Results: 802.11n / HT20 / CDD1 / BPSK / MCS0 / DAC 1**

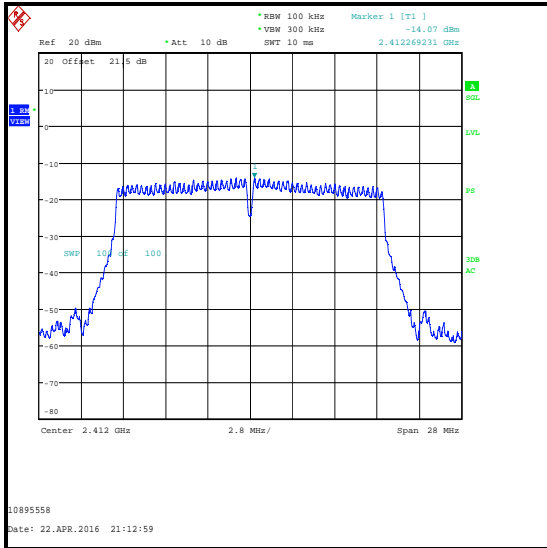

**Bottom Channel / DAC 1**

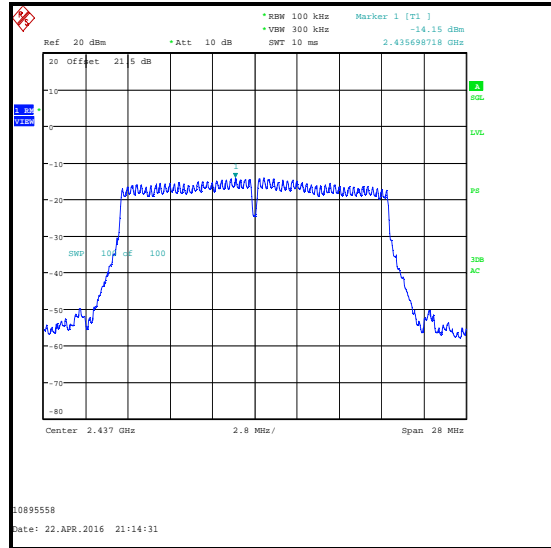

**Middle Channel / DAC 1**

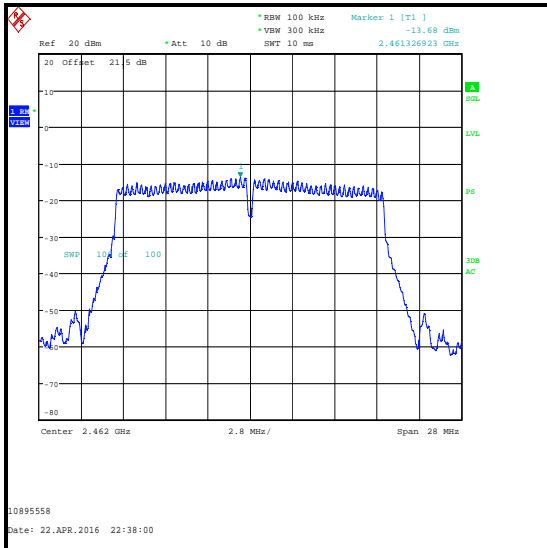

**Top Channel / DAC 1**

**Transmitter Power Spectral Density (continued)**

**Results: 802.11n / HT40 / SISO / 16QAM / MCS4 / DAC 0**

Channel	Output Power (dBm/3 kHz)	Duty Cycle Correction (dB)	Corrected Output Power (dBm/3 kHz)	Limit (dBm/3kHz)	Margin (dB)	Result
Bottom	-11.9	3.8	-8.1	8.0	16.1	Complied
Top	-13.6	3.8	-9.8	8.0	17.8	Complied

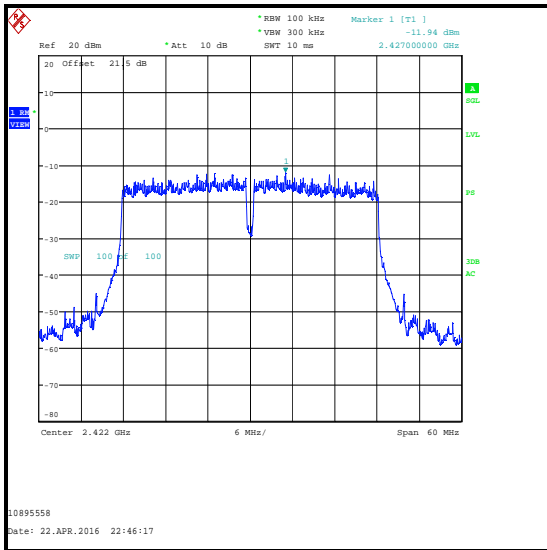

**Bottom Channel / DAC 0**

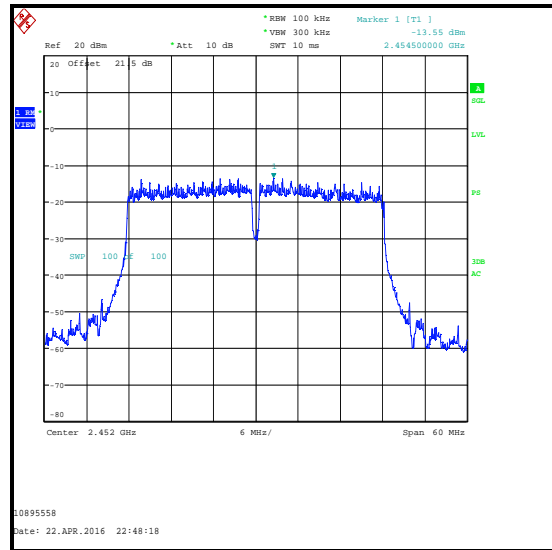

**Top Channel / DAC 0**

**Transmitter Power Spectral Density (continued)**

**Results: 802.11n / HT40 / CDD1 / BPSK / MCS0**

Channel	DAC 0			DAC 1		
	PSD (dBm / 3 kHz)	Duty Cycle Correction (dB)	Corrected PSD (dBm / 3 kHz)	PSD (dBm / 3 kHz)	Duty Cycle Correction (dB)	Corrected PSD (dBm / 3 kHz)
Bottom	-14.8	1.2	-13.6	-15.0	1.2	-13.8
Top	-14.6	1.2	-13.4	-17.0	1.2	-15.8

Channel	Corrected PSD at DAC 0 (dBm / 3 kHz)	Corrected PSD at DAC 1 (dBm / 3 kHz)	Combined PSD (dBm / 3 kHz)	PSD Limit (dBm / 3 kHz)	Margin (dB)	Result
Bottom	-13.6	-13.8	-10.7	8.0	18.7	Complied
Top	-13.4	-15.8	-11.4	8.0	19.4	Complied

**Results: 802.11n / HT40 / CDD1 / BPSK / MCS0 / DAC 0**



Bottom Channel / DAC 0

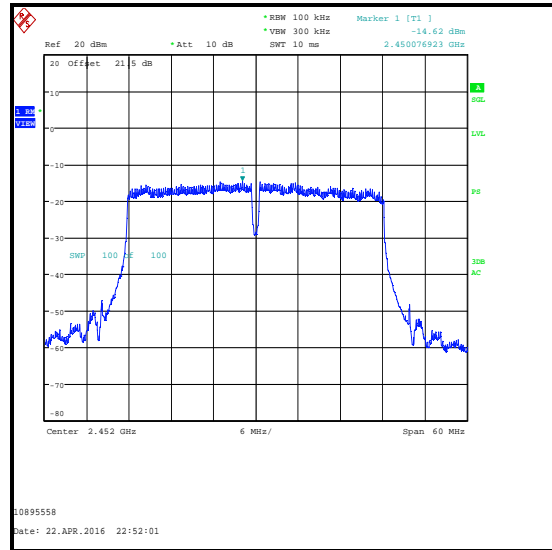

Top Channel / DAC 0

**Transmitter Power Spectral Density (continued)**

**Results: 802.11n / HT40 / CDD1 / BPSK / MCS0 / DAC 1**

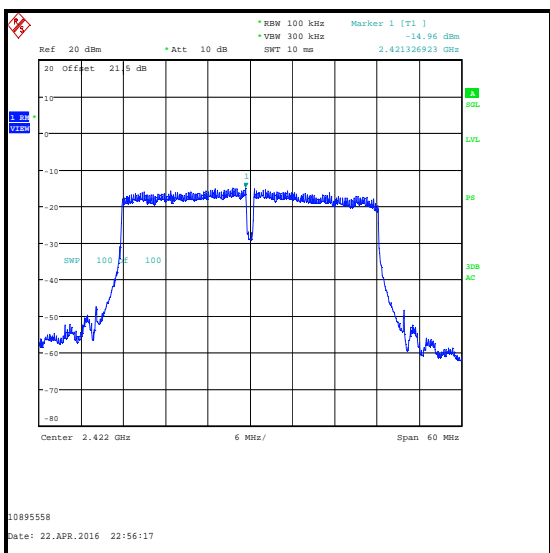

**Bottom Channel / DAC 1**

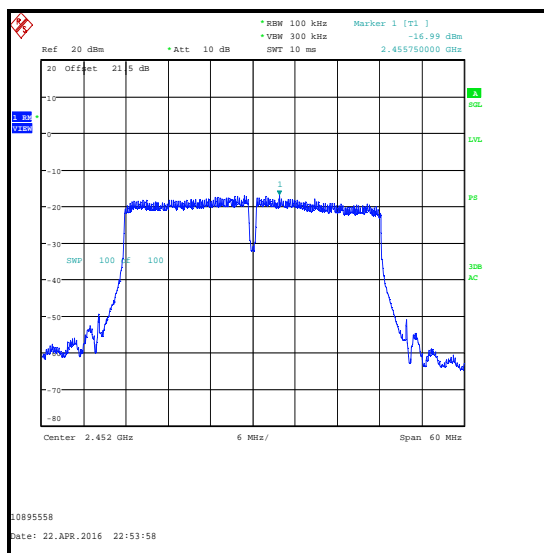

**Top Channel / DAC 1**

**Test Equipment Used:**

Asset No.	Instrument	Manufacturer	Type No.	Serial No.	Date Calibration Due	Cal. Interval (Months)
M2002	Thermohygrometer	Testo	608-H1	45041825	02 Apr 2017	12
M1874	Test Receiver	Rohde & Schwarz	ESU26	100553	11 Apr 2017	12
A2526	Attenuator	AtlanTecRF	AN18-20	832828#1	Calibrated before use	-
S0579	DC Power Supply	TTI	EX1810R	444110	Calibrated before use	-
M1251	Multimeter	Fluke	175	89170179	26 May 2016	12
G0607	Signal Generator	Rohde & Schwarz	SMU200A	100943	18 Jul 2016	36
M199	Power Meter	Rohde & Schwarz	NRVS	827023/075	11 Apr 2018	24
M1267	Power Sensor	Rohde & Schwarz	NRV-Z52	100155	15 Apr 2018	24

**5.2.5. Transmitter Maximum (Average) Output Power****Test Summary:**

<b>Test Engineer:</b>	Andrew Edwards	<b>Test Date:</b>	22 April 2016
<b>Test Sample MAC address:</b>	542AA22F8F19		

<b>FCC Reference:</b>	Part 15.247(b)(3)
<b>Test Method Used:</b>	FCC KDB 558074 Sections 9.2.2.4

**Environmental Conditions:**

<b>Temperature (°C):</b>	24
<b>Relative Humidity (%):</b>	30

**Transmitter Maximum (Average) Output Power (continued)****Note(s):**

1. All supported modes and channel widths were initially investigated on one channel. The modes that produced the highest power were:
  - 802.11b – DQPSK / 2 Mbps
  - 802.11g SISO – BPSK / 6 Mbps
  - 802.11g CDD1 – BPSK / 6 Mbps
  - 802.11n HT20 SISO – 16QAM / 39 Mbps / MCS4
  - 802.11n HT20 CDD1 – BPSK / 6.5 Mbps / MCS0
  - 802.11n HT40 SISO – 16QAM / 81 Mbps / MCS4
  - 802.11n HT40 CDD1 – BPSK / 13.5 Mbps / MCS0
2. Final measurements were performed using the above configurations on the bottom, middle and top channels. The power has been integrated over the 99% emission bandwidth. Plots for the occupied bandwidth are archived on the company server and available for inspection upon request.
3. For 802.11b the EUT transmits only from antenna 1, therefore conducted measurements were performed on port DAC 0 as this was found to produce the highest output power in SISO mode and therefore deemed worst case.
4. For 802.11g and 802.11n the EUT can transmit from both antennas, therefore conducted measurements were performed on both ports.
5. The EUT was transmitting at <98% duty cycle and testing was performed in accordance with KDB 558074 Section 9.2.2.4 Method AVGSA-2. The test receiver's integration function was used to integrate across the 99% occupied bandwidth.
6. For 20 MHz channel bandwidth, the test receiver's resolution bandwidth was set to 200 kHz and video bandwidth 1 MHz. An RMS detector was used with sweep time set to auto couple. Trace averaging was employed over 300 traces. The span was set to at least 1.5 times the 99% occupied emission bandwidth. The calculated duty cycle in section 5.2.3 was added to the measured power in order to compute the average power during the actual transmission time.
7. For 40 MHz channel bandwidth, the test receiver's resolution bandwidth was set to 500 kHz and video bandwidth 2 MHz. An RMS detector was used with sweep time set to auto couple. Trace averaging was employed over 300 traces. The span was set to at least 1.5 times the 99% occupied emission bandwidth. The calculated duty cycle in section 5.2.3 was added to the measured power in order to compute the average power during the actual transmission time.
8. For CDD1 modes, power was measured on both ports and then combined using the measure-and-sum technique stated in FCC KDB 662911 D01 Section E)1).
9. In accordance with KDB 662911 D01 Section F)2)f(i), for power measurements on IEEE 802.11 devices, no additional array gain has been added as there are less than 4 transmit antennas. Channel bandwidths of 40 MHz also require no additional array gain.
10. The test receiver was connected to the RF port on the EUT using suitable attenuation and RF cable. An RF level offset was entered on the test receiver to compensate for the loss of the attenuator and RF cable.



**Transmitter Maximum (Average) Output Power (continued)**

**Test setup:**

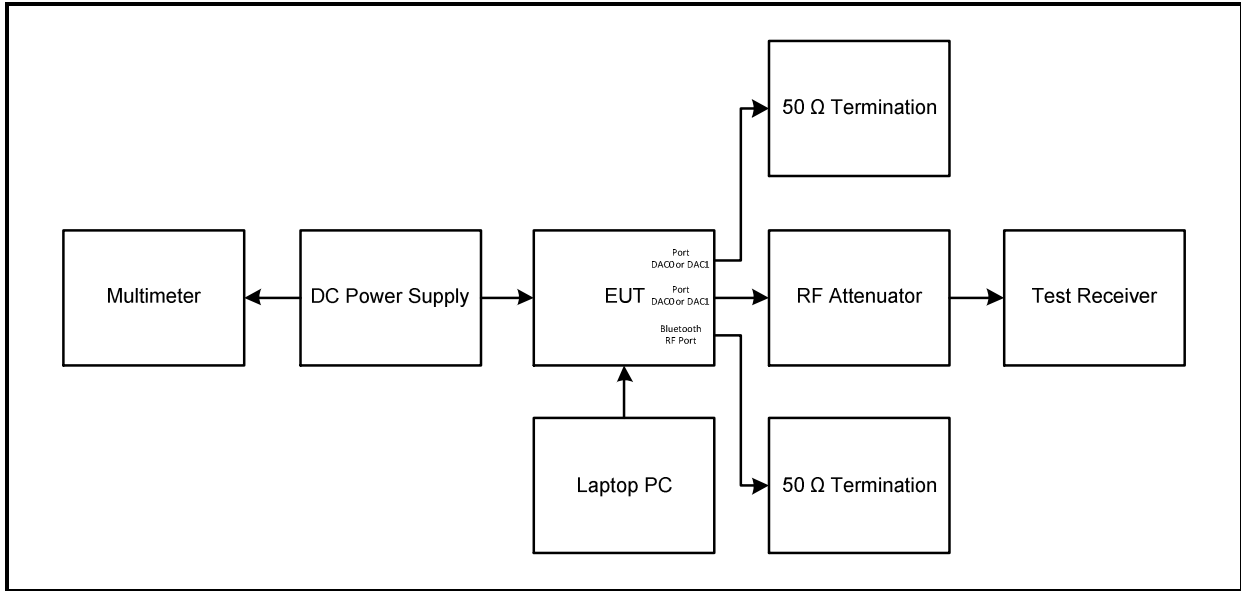

**Transmitter Maximum (Average) Output Power (continued)****Results: 802.11b / 20 MHz / DQPSK / 2 Mbps / DAC 0****Conducted Peak Limit Comparison**

Channel	Conducted Power (dBm)	Duty Cycle Correction (dB)	Corrected Conducted Power (dBm)	Conducted Power Limit (dBm)	Margin (dB)	Result
Bottom	11.5	0.2	11.7	30.0	18.3	Complied
Middle	12.1	0.2	12.3	30.0	17.7	Complied
Top	12.6	0.2	12.8	30.0	17.2	Complied

**De Facto EIRP Limit Comparison**

Channel	Corrected Conducted Power (dBm)	Declared Antenna Gain (dBi)	EIRP (dBm)	De Facto EIRP Limit (dBm)	Margin (dB)	Result
Bottom	11.7	5.4	17.1	36.0	18.9	Complied
Middle	12.3	5.4	17.7	36.0	18.3	Complied
Top	12.8	5.4	18.2	36.0	17.8	Complied

**Transmitter Maximum (Average) Output Power (continued)**

**Results: 802.11b / 20 MHz / DQPSK / 2 Mbps / DAC 0**

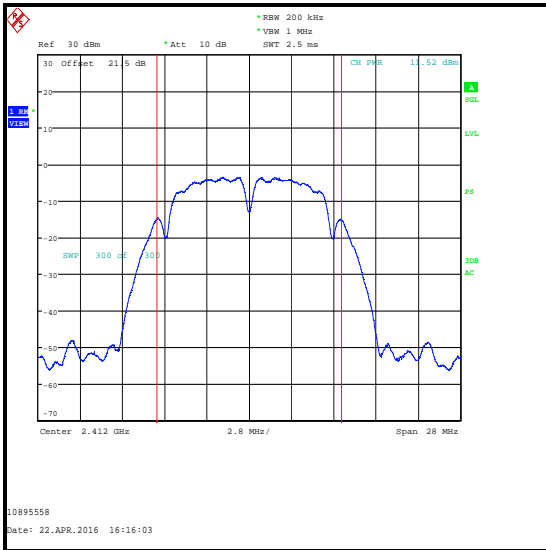

**Bottom Channel / DAC 0**



**Middle Channel / DAC 0**

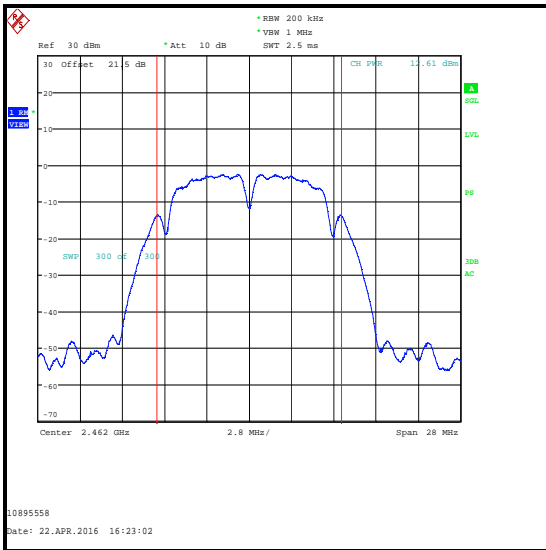

**Top Channel / DAC 0**

**Transmitter Maximum (Average) Output Power (continued)****Results: 802.11g / 20 MHz / SISO / BPSK / 6 Mbps / DAC 0****Conducted Peak Limit Comparison**

Channel	Conducted Power (dBm)	Duty Cycle Correction (dB)	Corrected Conducted Power (dBm)	Conducted Power Limit (dBm)	Margin (dB)	Result
Bottom	11.9	0.6	12.5	30.0	17.5	Complied
Middle	12.7	0.6	13.3	30.0	16.7	Complied
Top	12.7	0.6	13.3	30.0	16.7	Complied

**De Facto EIRP Limit Comparison**

Channel	Corrected Conducted Power (dBm)	Declared Antenna Gain (dBi)	EIRP (dBm)	De Facto EIRP Limit (dBm)	Margin (dB)	Result
Bottom	12.5	5.4	17.9	36.0	18.1	Complied
Middle	13.3	5.4	18.7	36.0	17.3	Complied
Top	13.3	5.4	18.7	36.0	17.3	Complied

**Transmitter Maximum (Average) Output Power (continued)**

**Results: 802.11g / 20 MHz / SISO / BPSK / 6 Mbps / DAC 0**

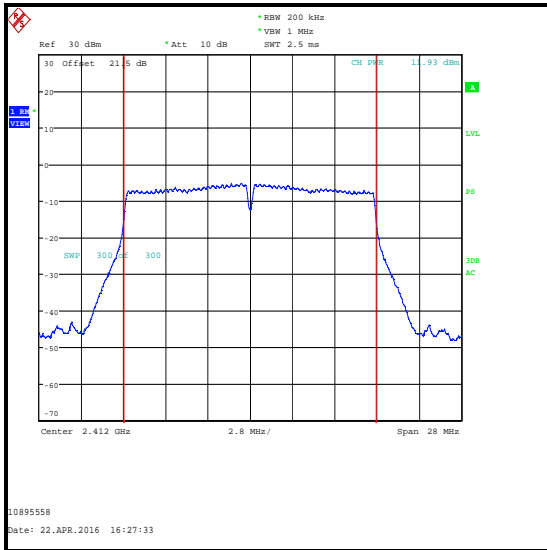

**Bottom Channel / DAC 0**

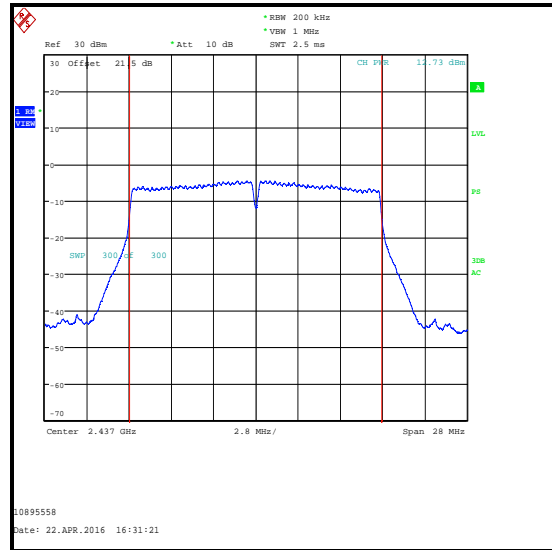

**Middle Channel / DAC 0**

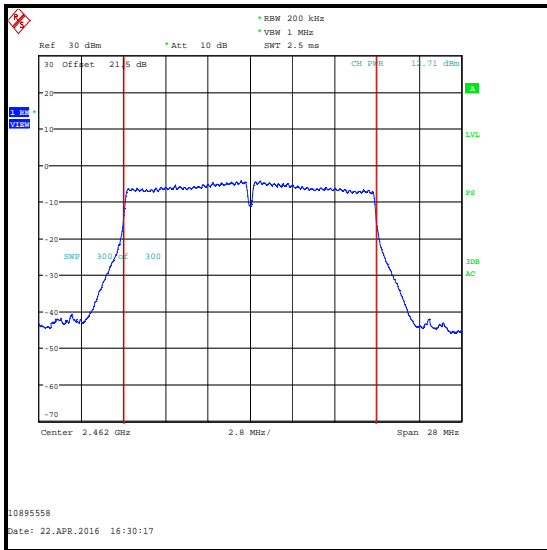

**Top Channel / DAC 0**

**Transmitter Maximum (Average) Output Power (continued)****Results: 802.11g / 20 MHz / CDD1 / BPSK / 6 Mbps****Conducted Peak Limit Comparison**

Channel	DAC 0			DAC 1		
	Conducted Peak Power (dBm)	Duty Cycle Correction (dB)	Corrected Conducted Peak Power (dBm)	Conducted Peak Power (dBm)	Duty Cycle Correction (dB)	Corrected Conducted Peak Power (dBm)
Bottom	8.7	0.6	9.3	8.5	0.6	9.1
Middle	9.8	0.6	10.4	9.5	0.6	10.1
Top	9.9	0.6	10.5	9.6	0.6	10.2

Channel	Corrected Conducted Peak Power DAC 0 (dBm)	Corrected Conducted Peak Power DAC 1 (dBm)	Combined Conducted Peak Power (dBm)	Conducted Peak Power Limit (dBm)	Margin (dB)	Result
Bottom	9.3	9.1	12.2	30.0	17.8	Complied
Middle	10.4	10.1	13.3	30.0	16.7	Complied
Top	10.5	10.2	13.4	30.0	16.6	Complied

**De Facto EIRP Limit Comparison**

Channel	Combined Conducted Peak Power (dBm)	Directional Antenna Gain (dBi)	EIRP (dBm)	De Facto EIRP Limit (dBm)	Margin (dB)	Result
Bottom	12.2	5.4	17.6	36.0	18.4	Complied
Middle	13.3	5.4	18.7	36.0	17.3	Complied
Top	13.4	5.4	18.8	36.0	17.2	Complied

**Transmitter Maximum (Average) Output Power (continued)**

**Results: 802.11g / 20 MHz / CDD1 / BPSK / 6 Mbps / DAC 0**

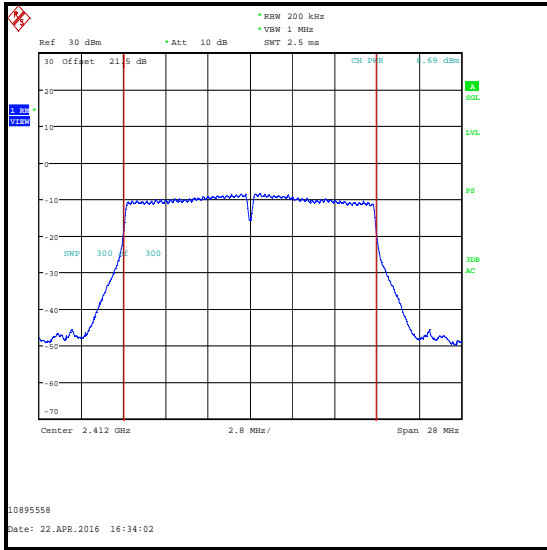

**Bottom Channel / DAC 0**

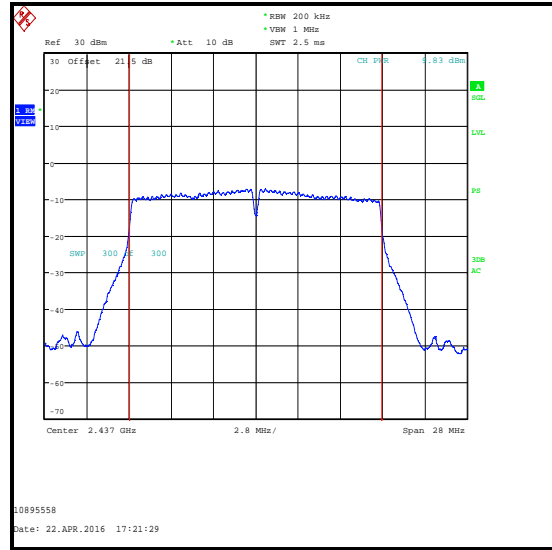

**Middle Channel / DAC 0**

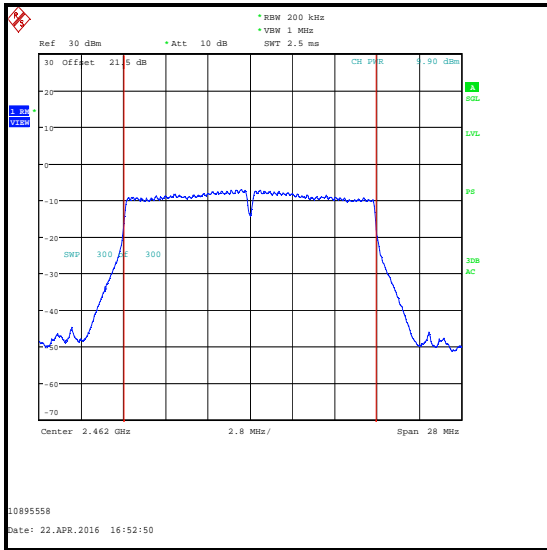

**Top Channel / DAC 0**

**Transmitter Maximum (Average) Output Power (continued)**

**Results: 802.11g / 20 MHz / CDD1 / BPSK / 6 Mbps / DAC 1**

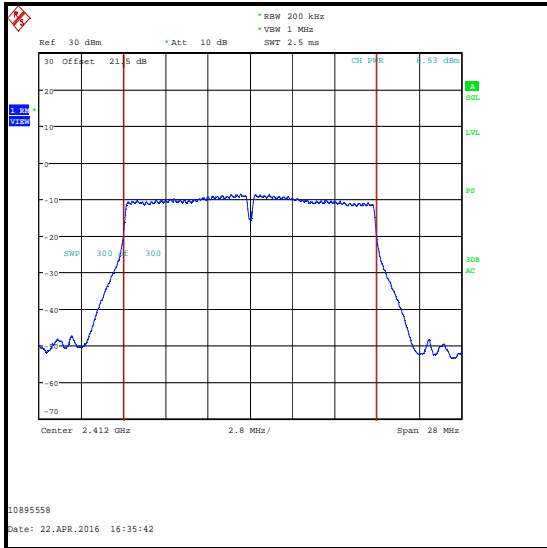

**Bottom Channel / DAC 1**

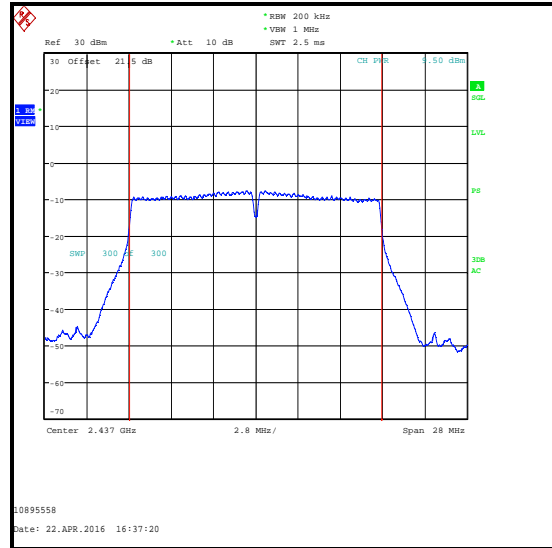

**Middle Channel / DAC 1**

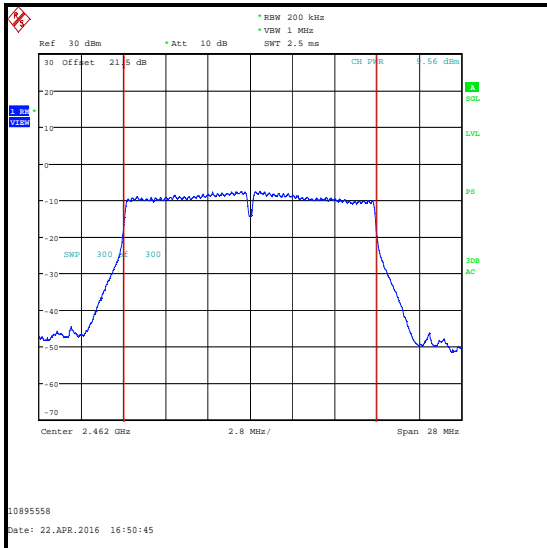

**Top Channel / DAC 1**



**Transmitter Maximum (Average) Output Power (continued)****Results: 802.11n / HT20 / SISO / 16QAM / MCS 4 / DAC 0****Conducted Peak Limit Comparison**

Channel	Conducted Power (dBm)	Duty Cycle Correction (dB)	Corrected Conducted Power (dBm)	Conducted Power Limit (dBm)	Margin (dB)	Result
Bottom	7.4	2.5	9.9	30.0	20.1	Complied
Middle	10.3	2.5	12.8	30.0	17.2	Complied
Top	8.7	2.5	11.2	30.0	18.8	Complied

**De Facto EIRP Limit Comparison**

Channel	Corrected Conducted Power (dBm)	Declared Antenna Gain (dBi)	EIRP (dBm)	De Facto EIRP Limit (dBm)	Margin (dB)	Result
Bottom	9.9	5.4	15.3	36.0	20.7	Complied
Middle	12.8	5.4	18.2	36.0	17.8	Complied
Top	11.2	5.4	16.6	36.0	19.4	Complied

**Transmitter Maximum (Average) Output Power (continued)**

**Results: 802.11n / HT20 / SISO / 16QAM / MCS 4 / DAC 0**

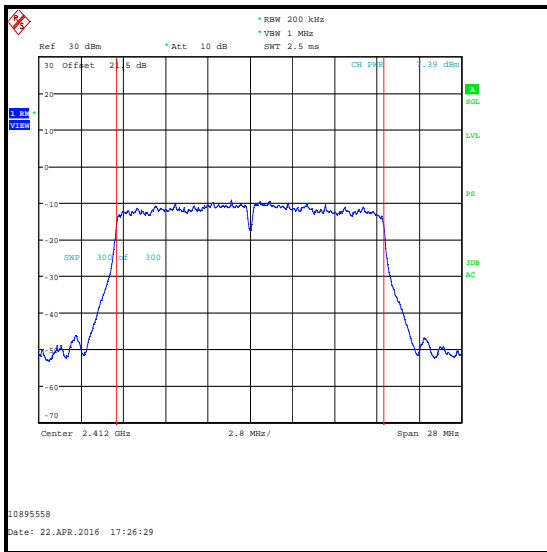

**Bottom Channel / DAC 0**

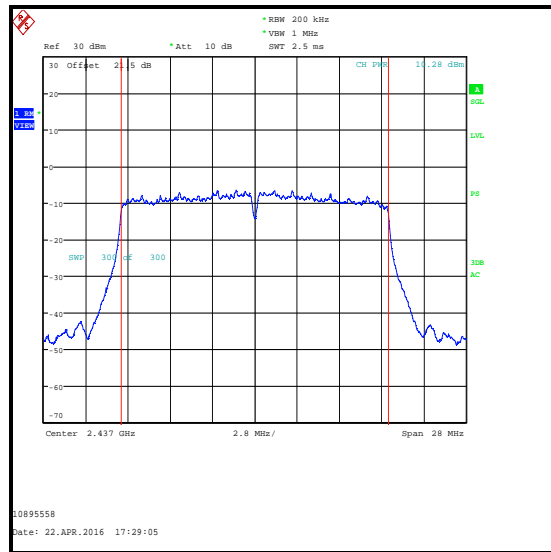

**Middle Channel / DAC 0**

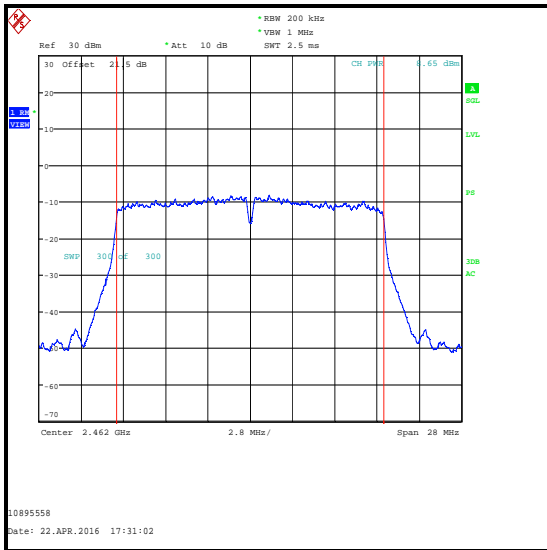

**Top Channel / DAC 0**

**Transmitter Maximum (Average) Output Power (continued)****Results: 802.11n / HT20 / CDD1 / BPSK / MCS0****Conducted Peak Limit Comparison**

Channel	DAC 0			DAC 1		
	Conducted Peak Power (dBm)	Duty Cycle Correction (dB)	Corrected Conducted Peak Power (dBm)	Conducted Peak Power (dBm)	Duty Cycle Correction (dB)	Corrected Conducted Peak Power (dBm)
Bottom	7.5	0.6	8.1	7.5	0.6	8.1
Middle	9.0	0.6	9.6	8.5	0.6	9.1
Top	8.9	0.6	9.5	8.1	0.6	8.7

Channel	Corrected Conducted Peak Power DAC 0 (dBm)	Corrected Conducted Peak Power DAC 1 (dBm)	Combined Conducted Peak Power (dBm)	Conducted Peak Power Limit (dBm)	Margin (dB)	Result
Bottom	8.1	8.1	11.1	30.0	18.9	Complied
Middle	9.6	9.1	12.4	30.0	17.6	Complied
Top	9.5	8.7	12.1	30.0	17.9	Complied

**De Facto EIRP Limit Comparison**

Channel	Combined Conducted Peak Power (dBm)	Directional Antenna Gain (dBi)	EIRP (dBm)	De Facto EIRP Limit (dBm)	Margin (dB)	Result
Bottom	11.1	5.4	16.5	36.0	19.5	Complied
Middle	12.4	5.4	17.8	36.0	18.2	Complied
Top	12.1	5.4	17.5	36.0	18.5	Complied

**Transmitter Maximum (Average) Output Power (continued)**

**Results: 802.11n / HT20 / CDD1 / BPSK / MCS0 / DAC 0**

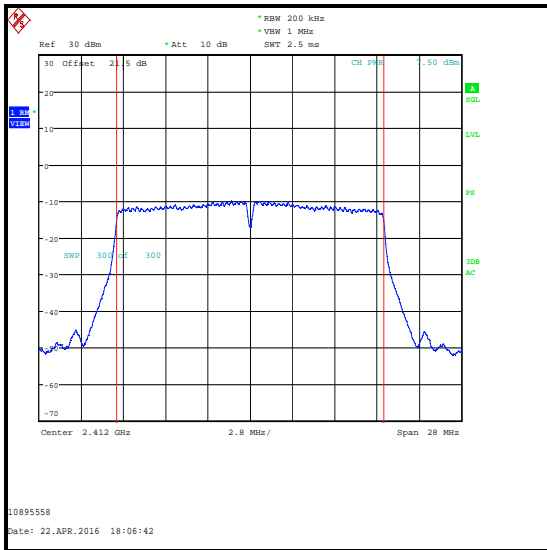

**Bottom Channel / DAC 0**

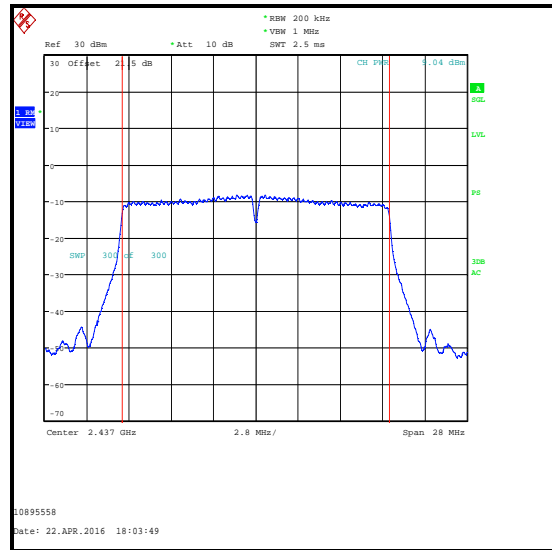

**Middle Channel / DAC 0**

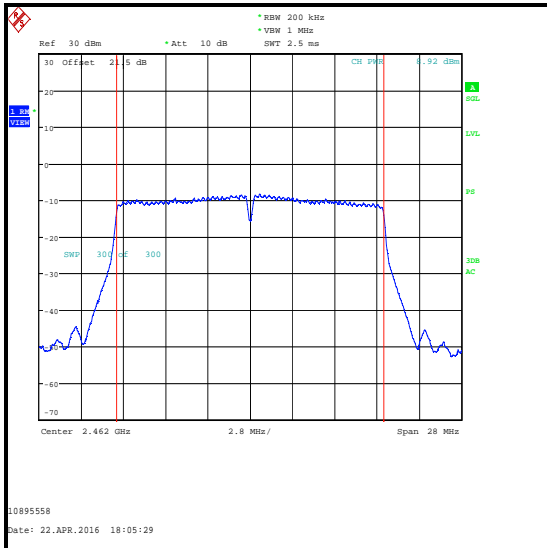

**Top Channel / DAC 0**

### Transmitter Maximum (Average) Output Power (continued)

#### Results: 802.11n / HT20 / CDD1 / BPSK / MCS0 / DAC 1



Bottom Channel / DAC 1

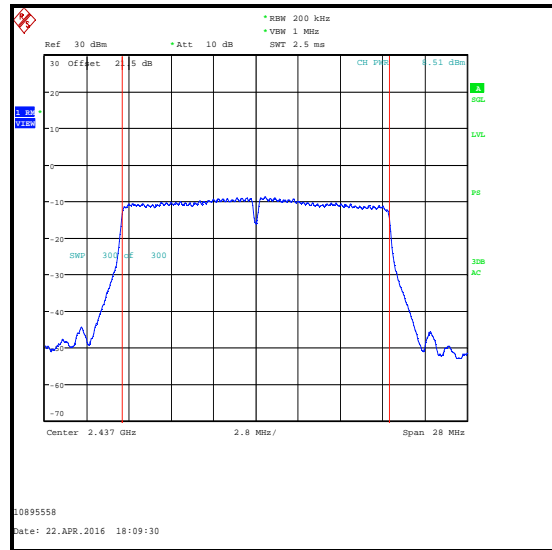

Middle Channel / DAC 1

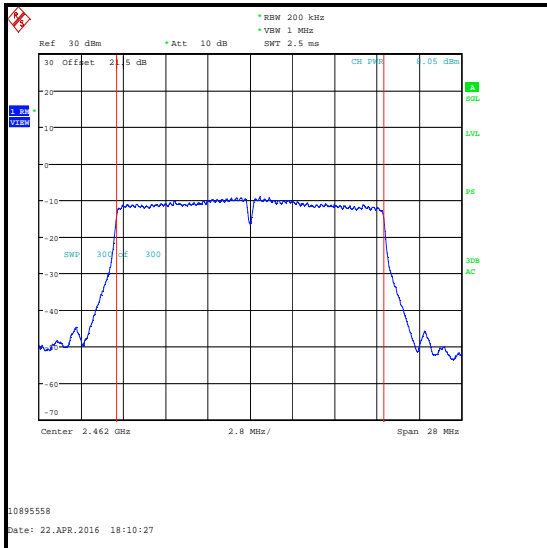

Top Channel / DAC 1

**Transmitter Maximum (Average) Output Power (continued)**

**Results: 802.11n / HT40 / SISO / 16QAM / MCS 4 / DAC 0**

**Conducted Peak Limit Comparison**

Channel	Conducted Power (dBm)	Duty Cycle Correction (dB)	Corrected Conducted Power (dBm)	Conducted Power Limit (dBm)	Margin (dB)	Result
Bottom	9.5	3.8	13.3	30.0	16.7	Complied
Top	8.4	3.8	12.2	30.0	17.8	Complied

**De Facto EIRP Limit Comparison**

Channel	Corrected Conducted Power (dBm)	Declared Antenna Gain (dBi)	EIRP (dBm)	De Facto EIRP Limit (dBm)	Margin (dB)	Result
Bottom	13.3	5.4	18.7	36.0	17.3	Complied
Top	12.2	5.4	17.6	36.0	18.4	Complied

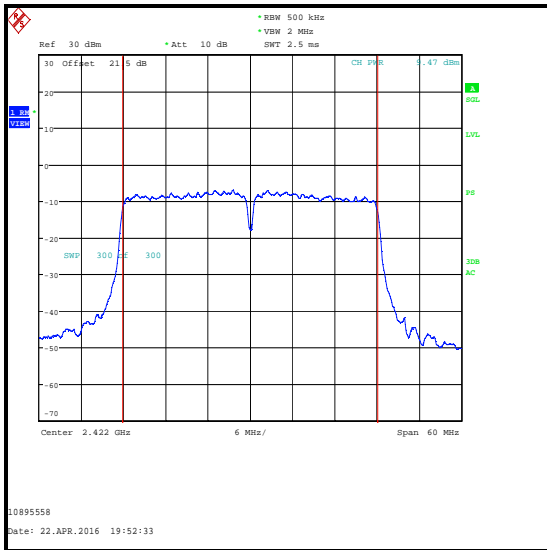

**Bottom Channel / DAC 0**



**Top Channel / DAC 0**

**Transmitter Maximum (Average) Output Power (continued)****Results: 802.11n / HT40 / CDD1 / BPSK / MCS0**

Channel	DAC 0			DAC 1		
	Conducted Peak Power (dBm)	Duty Cycle Correction (dB)	Corrected Conducted Peak Power (dBm)	Conducted Peak Power (dBm)	Duty Cycle Correction (dB)	Corrected Conducted Peak Power (dBm)
Bottom	8.6	1.2	9.8	7.6	1.2	8.8
Top	8.7	1.2	9.9	7.9	1.2	9.1

Channel	Corrected Conducted Peak Power DAC 0 (dBm)	Corrected Conducted Peak Power DAC 1 (dBm)	Combined Conducted Peak Power (dBm)	Conducted Peak Power Limit (dBm)	Margin (dB)	Result
Bottom	9.8	8.8	12.3	30.0	17.7	Complied
Top	9.9	9.1	12.5	30.0	17.5	Complied

**De Facto EIRP Limit Comparison**

Channel	Combined Conducted Peak Power (dBm)	Directional Antenna Gain (dBi)	EIRP (dBm)	De Facto EIRP Limit (dBm)	Margin (dB)	Result
Bottom	12.3	5.4	17.7	36.0	18.3	Complied
Top	12.5	5.4	17.9	36.0	18.1	Complied

**Transmitter Maximum (Average) Output Power (continued)**

**Results: 802.11n / HT40 / CDD1 / BPSK / MCS0 / DAC 0**

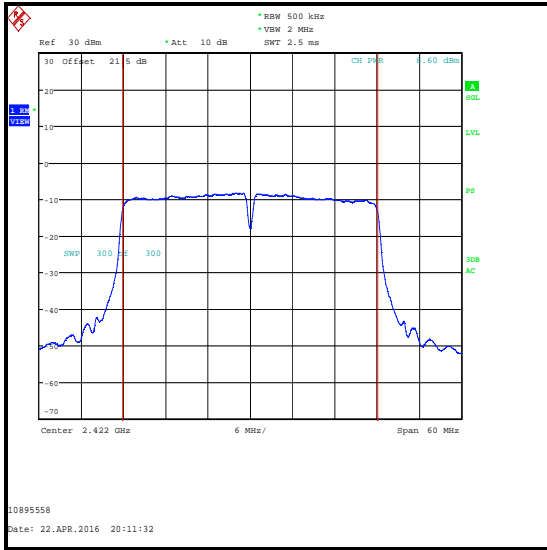

**Bottom Channel / DAC 0**

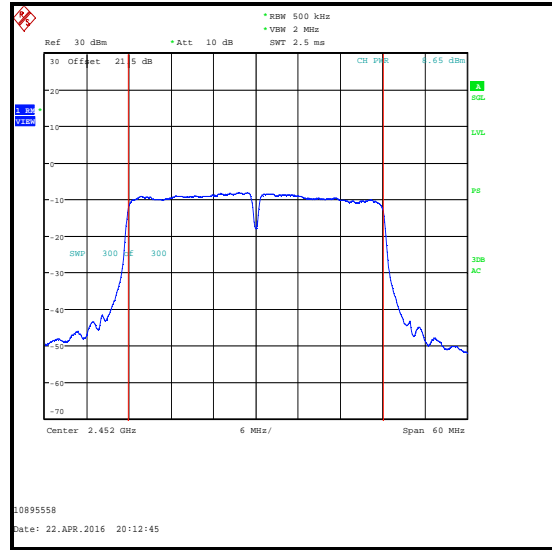

**Top Channel / DAC 0**

**Results: 802.11n / HT40 / CDD1 / BPSK / MCS0 / DAC 1**

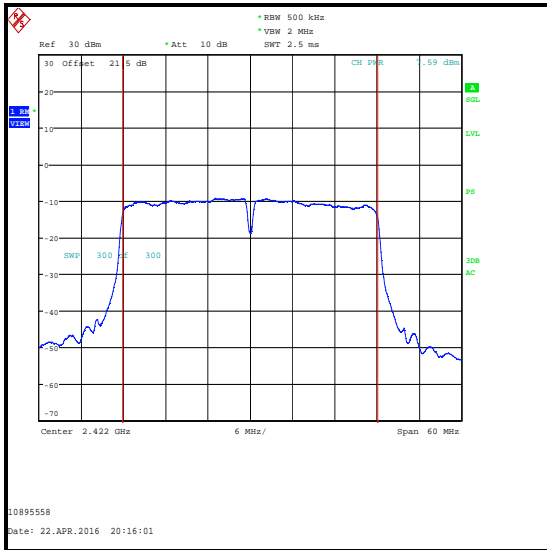

**Bottom Channel / DAC 1**

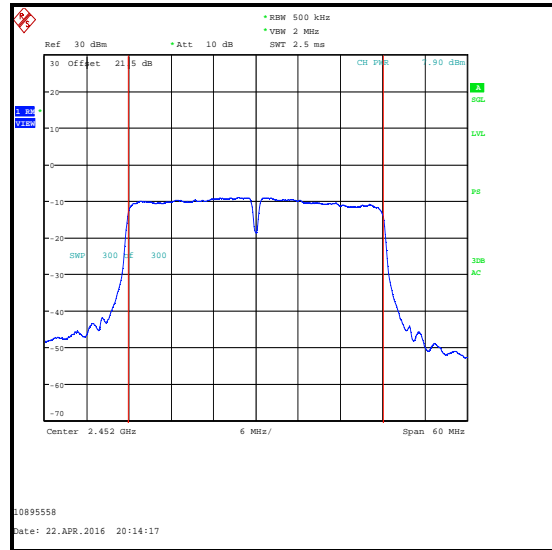

**Top Channel / DAC 1**



**Transmitter Maximum (Average) Output Power (continued)****Test Equipment Used:**

Asset No.	Instrument	Manufacturer	Type No.	Serial No.	Date Calibration Due	Cal. Interval (Months)
M2002	Thermohygrometer	Testo	608-H1	45041825	02 Apr 2017	12
M1874	Test Receiver	Rohde & Schwarz	ESU26	100553	11 Apr 2017	12
A2526	Attenuator	AtlanTecRF	AN18-20	832828#1	Calibrated before use	-
S0579	DC Power Supply	TTI	EX1810R	444110	Calibrated before use	-
M1251	Multimeter	Fluke	175	89170179	26 May 2016	12
G0607	Signal Generator	Rohde & Schwarz	SMU200A	100943	18 Jul 2016	36
M199	Power Meter	Rohde & Schwarz	NRVS	827023/075	11 Apr 2018	24
M1267	Power Sensor	Rohde & Schwarz	NRV-Z52	100155	15 Apr 2018	24

**5.2.6. Transmitter Radiated Emissions****Test Summary:**

<b>Test Engineer:</b>	Andrew Edwards	<b>Test Date:</b>	17 March 2016
<b>Test Sample Serial Number:</b>	92777		

<b>FCC Reference:</b>	Parts 15.247(d) & 15.209(a)
<b>Test Method Used:</b>	ANSI C63.10 Sections 6.3 and 6.5
<b>Frequency Range</b>	30 MHz to 1000 MHz

**Environmental Conditions:**

<b>Temperature (°C):</b>	24
<b>Relative Humidity (%):</b>	36

**Note(s):**

1. The final measured value, for the given emission, in the table below incorporates the calibrated antenna factor and cable loss.
2. The preliminary scans showed similar emission levels below 1 GHz, for each channel of operation. Therefore final radiated emissions measurements were performed with the EUT set to the middle channel only.
3. All other emissions shown on the pre-scan plots were investigated and found to be ambient, or >20 dB below the applicable limit or below the measurement system noise floor.
4. Measurements below 1 GHz were performed in a semi-anechoic chamber (Asset Number K0001) at a distance of 3 metres. The EUT was placed at a height of 80 cm above the reference ground plane in the centre of the chamber turntable. Maximum emission levels were determined by height searching the measurement antenna over the range 1 metre to 4 metres.
5. Pre-scans were performed and markers placed on the highest measured levels. The test receiver resolution bandwidth was set to 100 kHz and video bandwidth 300 kHz. A peak detector was used, sweep time was set to auto and trace mode was Max Hold.
6. Final measurements were performed on the marker frequencies and the results entered into the table below. The test receiver resolution bandwidth was set to 120 kHz, using a CISPR quasi-peak detector and span big enough to see the whole emission.

**Transmitter Radiated Emissions (continued)**

**Test setup for radiated measurements:**

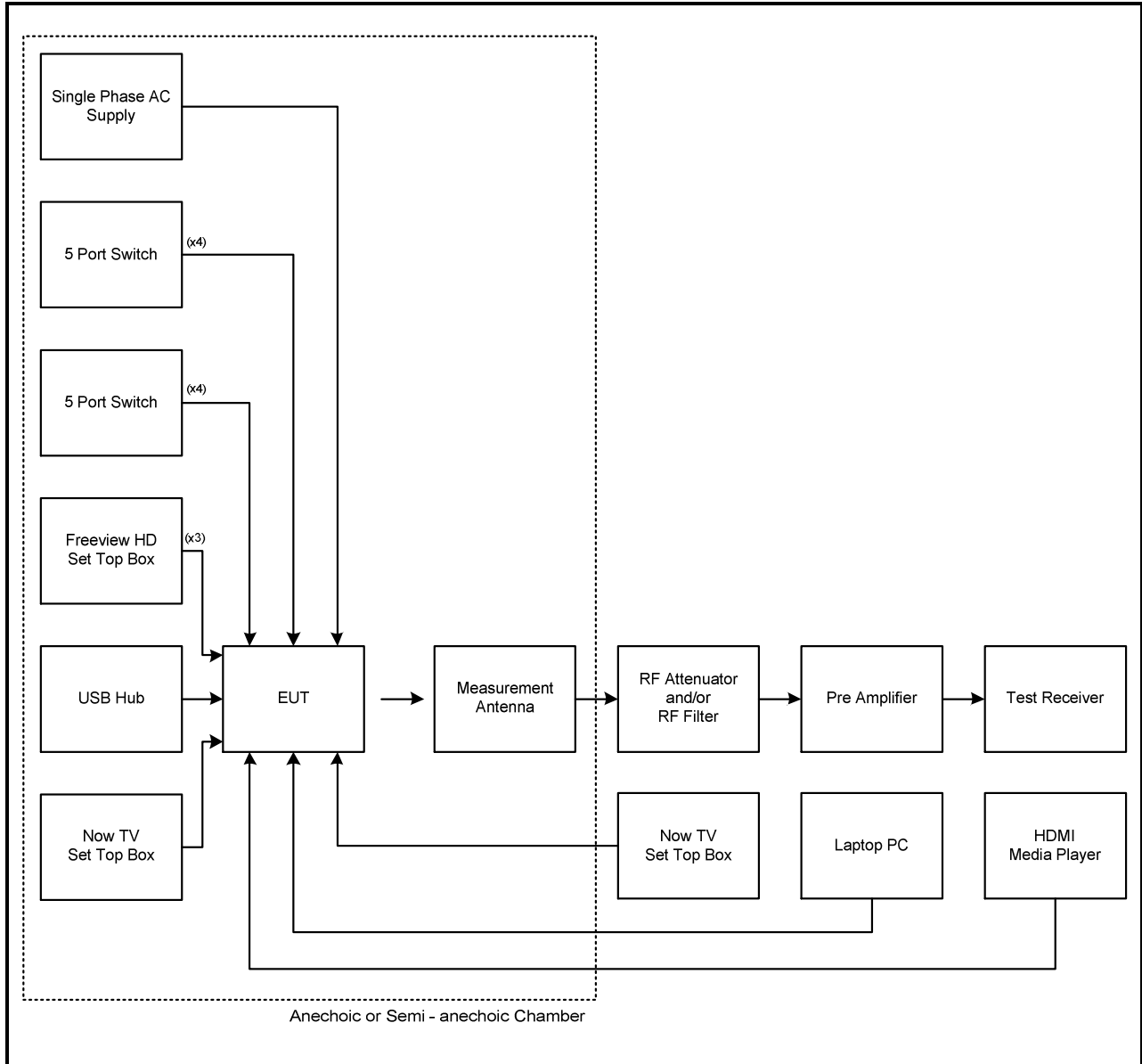

*Note: The number in brackets relates to the quantity of cables which were connected between the TV and the support equipment.*

**Transmitter Radiated Emissions (continued)**

**Results: Middle Channel / 802.11g / 6 Mbps / SISO / Antenna 1**

Frequency (MHz)	Antenna Polarity	Level (dB $\mu$ V/m)	Limit (dB $\mu$ V/m)	Margin (dB)	Result
73.713	Vertical	22.2	40.0	17.8	Complied

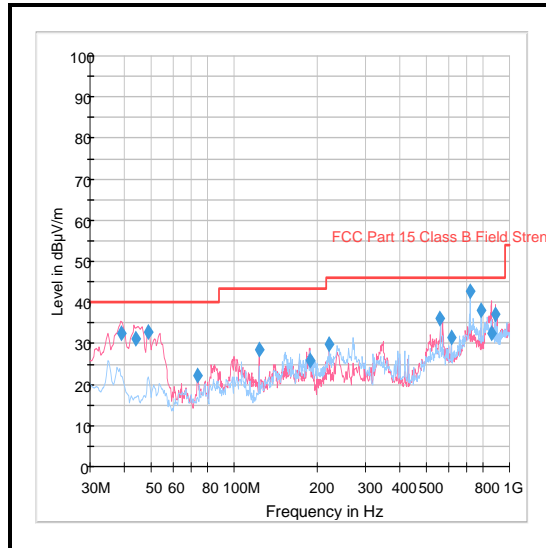

*Note: This plot is a pre-scan and for indication purposes only. For final measurements, see accompanying table.*

**Test Equipment Used:**

Asset No.	Instrument	Manufacturer	Type No.	Serial No.	Date Calibration Due	Cal. Interval (Months)
M1945	Thermohygrometer	JM Handelspunkt	30.5015.01	None stated	23 Apr 2016	12
K0001	5m RSE Chamber	Rainford EMC	N/A	N/A	12 Jan 2017	12
M1273	Test Receiver	Rohde & Schwarz	ESIB26	100275	19 Mar 2016	12
G0543	Amplifier	Sonoma	310N	230801	29 May 2016	3
A259	Antenna	Chase	CBL6111	1513	09 Apr 2016	12
A1834	Attenuator	Hewlett Packard	8491B	10444	30 Mar 2017	12

**Transmitter Radiated Emissions (continued)****Test Summary:**

<b>Test Engineers:</b>	David Doyle & Andrew Edwards	<b>Test Dates:</b>	16 March 2016 & 21 March 2016
<b>Test Sample Serial Number:</b>	92777		

<b>FCC Reference:</b>	Parts 15.247(d) & 15.209(a)
<b>Test Method Used:</b>	ANSI C63.10 Sections 6.3 and 6.6
<b>Frequency Range</b>	1 GHz to 25 GHz

**Environmental Conditions:**

<b>Temperature (°C):</b>	21 to 22
<b>Relative Humidity (%):</b>	31 to 33

**Note(s):**

1. Transmitter radiated spurious emissions tests were performed with the EUT transmitting in 802.11g / 6 Mbps / SISO / Antenna 1, as this was found to transmit the highest power and therefore deemed worst case.
2. The final measured value, for the given emission, in the table below incorporates the calibrated antenna factor and cable loss.
3. All other emissions shown on the pre-scans were investigated and found to be ambient, or > 20 dB below the appropriate limit or below the noise floor of the measurement system.
4. The emission shown approximately at 2437 MHz on the 1 GHz to 4 GHz plot is the EUT fundamental.
5. Pre-scans above 1 GHz were performed in a fully anechoic chamber (Asset Number K0002) at a distance of 3 metres. The EUT was placed at a height of 1.5 metres above the test chamber floor in the centre of the chamber turntable. All measurement antennas were placed at a fixed height of 1.5 metres above the test chamber floor, in line with the EUT. Final measurements above 1 GHz were performed in a semi-anechoic chamber (Asset Number K0001) at a distance of 3 metres. The EUT was placed at a height of 1.5 m above the reference ground plane in the centre of the chamber turntable. Maximum emission levels were determined by height searching the measurement antenna over the range 1 metre to 4 metres.
6. Pre-scans were performed and a marker placed on the highest measured level of the appropriate plot. The test receiver resolution bandwidth was set to 1 MHz and video bandwidth 3 MHz. The sweep time was set to auto.
7. Pre-scan plots 4 to 6 and 6 to 8 GHz were performed with a peak detector vs average limit, all other pre-scan were performed using a peak and average detector against their appropriate limits.
8. \*In accordance with ANSI C63.10 Section 6.6.4.3, Note 1, if the peak measured value complies with the average limit, it is unnecessary to perform an average measurement.
9. The six highest spurious emissions relative to the limit were recorded in table below, as stated in ANSI C63.10 Section 6.6.4.3.
10. Radiated measurements were performed under a different job number as shown on the plots below.

**Transmitter Radiated Emissions (continued)****Results: Peak / Bottom Channel / 802.11g / 6 Mbps / SISO / Antenna 1**

Frequency (MHz)	Antenna Polarity	Peak Level (dB $\mu$ V/m)	Peak Limit (dB $\mu$ V/m)	Margin (dB)	Result
1048.718	Horizontal	49.7	54.0*	4.3	Complied
1142.444	Vertical	50.5	54.0*	3.5	Complied
1187.865	Horizontal	48.0	54.0*	6.0	Complied
1709.889	Vertical	54.3	74.0	19.7	Complied
2857.454	Vertical	56.1	74.0	17.9	Complied
7511.809	Horizontal	53.4	54.0*	0.6	Complied

**Results: Average / Bottom Channel / 802.11g / 6 Mbps / SISO / Antenna 1**

Frequency (MHz)	Antenna Polarity	Average Level (dB $\mu$ V/m)	Average Limit (dB $\mu$ V/m)	Margin (dB)	Result
1708.038	Vertical	44.7	54.0	9.3	Complied
2860.499	Vertical	45.1	54.0	8.9	Complied

**Results: Peak / Middle Channel / 802.11g / 6 Mbps / SISO / Antenna 1**

Frequency (MHz)	Antenna Polarity	Peak Level (dB $\mu$ V/m)	Peak Limit (dB $\mu$ V/m)	Margin (dB)	Result
1048.718	Horizontal	49.7	54.0*	4.3	Complied
1142.444	Vertical	50.5	54.0*	3.5	Complied
1709.889	Vertical	54.3	74.0	19.7	Complied
2857.454	Vertical	56.1	74.0	17.9	Complied
4875.522	Horizontal	50.8	54.0*	3.2	Complied
7511.809	Horizontal	53.4	54.0*	0.6	Complied

**Results: Average / Middle Channel / 802.11g / 6 Mbps / SISO / Antenna 1**

Frequency (MHz)	Antenna Polarity	Average Level (dB $\mu$ V/m)	Average Limit (dB $\mu$ V/m)	Margin (dB)	Result
1708.038	Vertical	44.7	54.0	9.3	Complied
2860.499	Vertical	45.1	54.0	8.9	Complied

**Transmitter Radiated Emissions (continued)****Results: Peak / Top Channel / 802.11g / 6 Mbps / SISO / Antenna 1**

Frequency (MHz)	Antenna Polarity	Peak Level (dB $\mu$ V/m)	Peak Limit (dB $\mu$ V/m)	Margin (dB)	Result
1048.718	Horizontal	49.7	54.0*	4.3	Complied
1187.865	Horizontal	48.0	54.0*	6.0	Complied
1709.889	Vertical	54.3	74.0	19.7	Complied
2857.454	Vertical	56.1	74.0	17.9	Complied
4922.436	Horizontal	52.5	54.0*	1.5	Complied
7511.809	Horizontal	53.4	54.0*	0.6	Complied

**Results: Average / Top Channel / 802.11g / 6 Mbps / SISO / Antenna 1**

Frequency (MHz)	Antenna Polarity	Average Level (dB $\mu$ V/m)	Average Limit (dB $\mu$ V/m)	Margin (dB)	Result
1708.038	Vertical	44.7	54.0	9.3	Complied
2860.499	Vertical	45.1	54.0	8.9	Complied

**Transmitter Radiated Emissions (continued)**

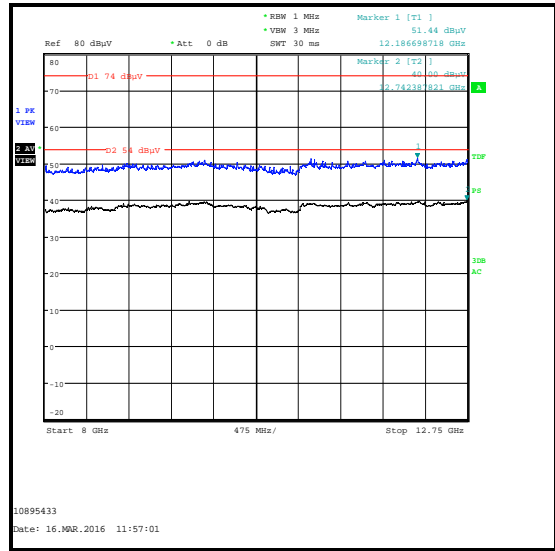
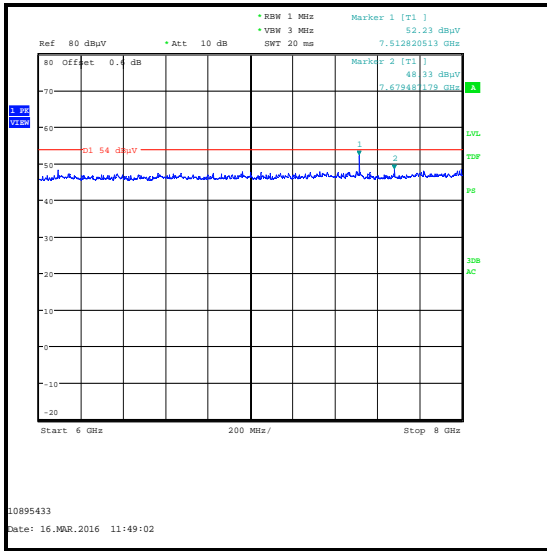
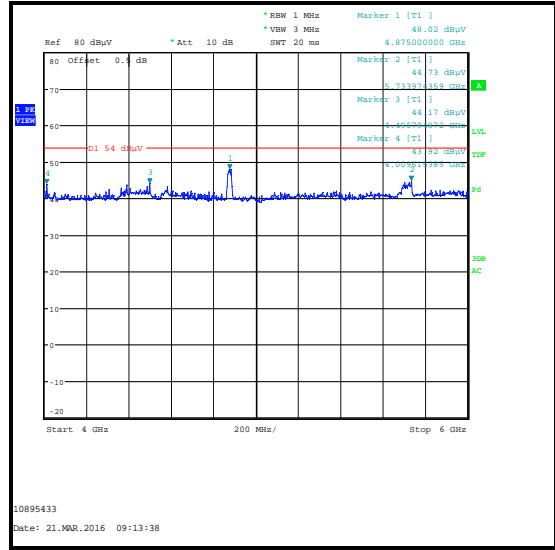
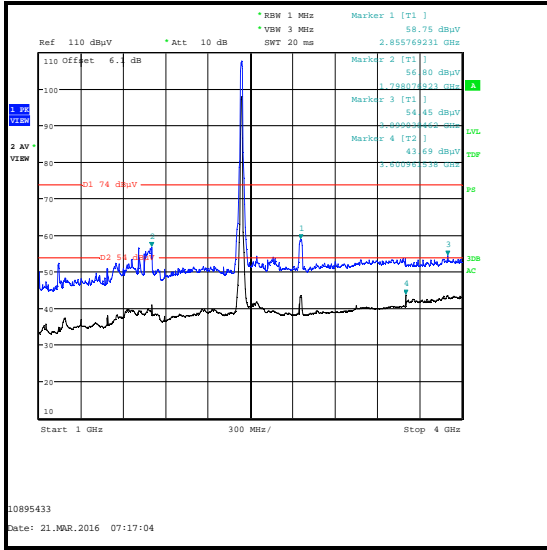



**Transmitter Radiated Emissions (continued)**

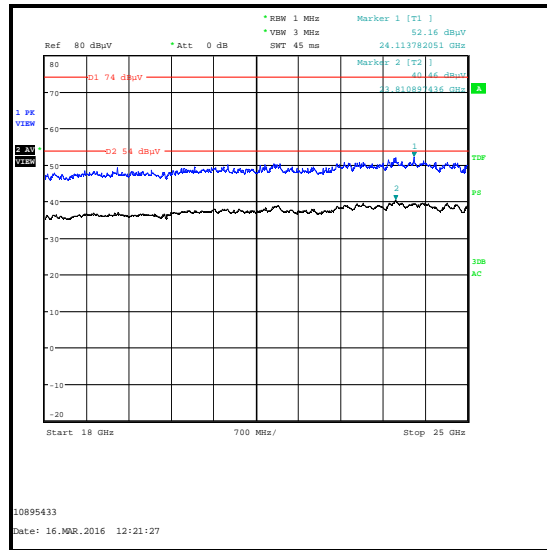
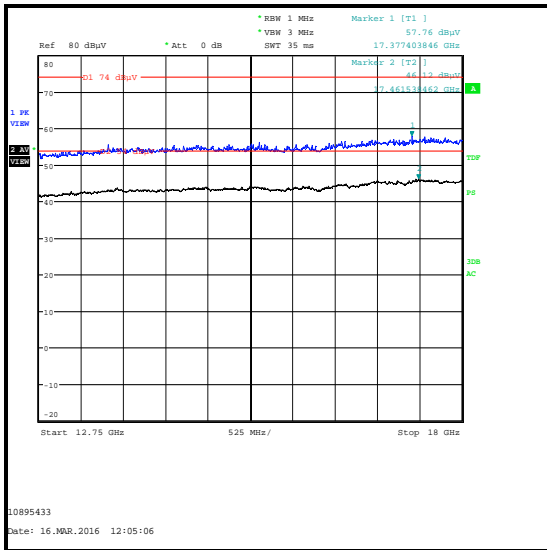

Note: These plots are pre-scans and for indication purposes only. For final measurements, see accompanying tables.

**Test Equipment Used:**

Asset No.	Instrument	Manufacturer	Type No.	Serial No.	Date Calibration Due	Cal. Interval (Months)
M1656	Thermohyrometer	JM Handelspunkt	30.5015.13	None stated	23 Apr 2016	12
K0002	3m RSE Chamber	Rainford EMC	N/A	N/A	21 Dec 2016	12
M1874	Test Receiver	Rohde & Schwarz	ESU26	100553	12 Jun 2016	12
A1534	Pre Amplifier	Hewlett Packard	8449B	3008A00405	19 Dec 2016	12
A1818	Antenna	EMCO	3115	00075692	17 Dec 2016	12
A253	Antenna	Flann Microwave	12240-20	128	17 Dec 2016	12
A254	Antenna	Flann Microwave	14240-20	139	17 Dec 2016	12
A255	Antenna	Flann Microwave	16240-20	519	17 Dec 2016	12
A256	Antenna	Flann Microwave	18240-20	400	17 Dec 2016	12
A436	Antenna	Flann Microwave	20240-20	330	19 Dec 2016	12
A239	Attenuator	Huber & Suhner	6806.17.B	Not stated	05 May 2016	12
A1975	High Pass Filter	AtlanTecRF	AFH-03000	090424010	17 Apr 2016	12
M1945	Thermohyrometer	JM Handelspunkt	30.5015.01	None stated	23 Apr 2016	12
K0001	5m RSE Chamber	Rainford EMC	N/A	N/A	12 Jan 2017	12
M1124	Test Receiver	Rohde & Schwarz	ESIB26	100046	18 Nov 2016	12

**5.2.7. Transmitter Band Edge Radiated Emissions****Test Summary:**

<b>Test Engineers:</b>	Nick Steele & David Doyle	<b>Test Dates:</b>	16 March 2016 & 21 March 2016
<b>Test Sample Serial Number:</b>	92777		

<b>FCC Reference:</b>	Parts 15.247(d) & 15.209(a)
<b>Test Method Used:</b>	ANSI C63.10 Section 6.10 & FCC KDB 558074 Section 11

**Environmental Conditions:**

<b>Temperature (°C):</b>	21 to 22
<b>Relative Humidity (%):</b>	32 to 33

**Note(s):**

- All supported modes and channel widths were initially investigated on one channel. The modes that produced the highest power and widest bandwidth were:

- o 802.11b – DQPSK / 2 Mbps / DAC0
- o 802.11g SISO – BPSK / 6 Mbps / DAC 0
- o 802.11g CDD1 – BPSK / 6 Mbps
- o 802.11n HT20 SISO – QPSK / 13 Mbps / MCS1
- o 802.11n HT20 SISO – 16QAM / 39 Mbps / MCS4
- o 802.11n HT20 CDD1 – BPSK / 6.5 Mbps / MCS0
- o 802.11n HT40 SISO – BPSK / 13.5 Mbps / MCS0
- o 802.11n HT40 SISO – 16QAM / 81 Mbps / MCS4
- o 802.11n HT40 CDD1 – BPSK / 13.5 Mbps / MCS0

Final measurements were performed with the above configurations.

- For SISO modes, the EUT was transmitting from Port 1 (DAC 0) only as this Port emits the highest output power level and was therefore deemed to be worst case. For CDD1 modes, the EUT was transmitting from both ports.
- The final measured value, for the given emission, in the table below incorporates the calibrated antenna factor and cable loss.
- The maximum conducted (average) output power was previously measured. In accordance with FCC KDB 558074 Section 11.1(b), the lower band edge measurement should be performed with a peak detector and the -30 dBc limit applied.
- As the lower band edge falls within a non-restricted band, only peak measurements are required. In accordance with FCC KDB 558074 Section 11.1, the test method in Section 11.3 was followed: the test receiver resolution bandwidth was set to 100 kHz and video bandwidth 300 kHz. A peak detector was used, sweep time was set to auto and trace mode was Max Hold. The test receiver was left to sweep for a sufficient length of time in order to maximise the carrier level and out-of-band emissions. A marker and corresponding reference level line were placed on the peak of the carrier. As the maximum conducted (average) output power was measured using an RMS detector in accordance with FCC KDB 558074 Section 9.2.2.4 an out-of-band limit line was placed 30 dB (FCC KDB 558074 Section 11.1(b)) below the peak level. A marker was placed on the band edge spot frequencies and a second marker placed on the highest emission level in the adjacent non-restricted band of operation (where a higher level emission was present). Marker frequencies and levels were recorded.

**Transmitter Band Edge Radiated Emissions (continued)****Note(s):**

6. As the upper band edge falls within a restricted band both peak and average measurements were recorded by placing a marker at the edge of the band. For peak measurements the test receiver resolution bandwidth was set to 1 MHz and video bandwidth 3 MHz. A peak detector was used, sweep time was set to auto and trace mode was Max Hold. For average measurements the test receiver resolution bandwidth was set to 1 MHz and video bandwidth 3 MHz. An average detector was used, sweep time was set to auto and trace mode was Max Hold. The test receiver was left to sweep for a sufficient length of time in order to maximise the carrier level and out-of-band emissions. A marker was placed on the band edge spot frequencies and a second marker placed on the highest emission level in the adjacent restricted band of operation (where a higher level emission was present). Marker frequencies and levels were recorded.
7. There is a restricted band 10 MHz below the lower band edge. The test receiver was set up as follows: the RBW set to 1 MHz, the VBW set to 3 MHz, with the sweep time set to auto couple. Peak and average measurements were performed with their respective detectors. Markers were placed on the highest point on each trace.
8. Radiated measurements were performed under a different job number as shown on the plots below.

**Transmitter Band Edge Radiated Emissions (continued)****Results: 802.11b / 20 MHz / DQPSK / 2 Mbps / DAC 0****Results: Lower Band Edge**

Frequency (MHz)	Level (dB $\mu$ V/m)	-30 dBc Limit (dB $\mu$ V/m)	Margin (dB)	Result
2400	48.6	63.8	15.2	Complied

**Results: Upper Band Edge / Restricted Band / Peak**

Frequency (MHz)	Level (dB $\mu$ V/m)	Limit (dB $\mu$ V/m)	Margin (dB)	Result
2387.436	55.4	74.0	18.6	Complied
2483.5	59.8	74.0	14.2	Complied
2483.740	61.2	74.0	12.8	Complied

**Results: Upper Band Edge / Restricted Band / Average**

Frequency (MHz)	Level (dB $\mu$ V/m)	Limit (dB $\mu$ V/m)	Margin (dB)	Result
2337.564	43.3	54.0	10.7	Complied
2483.5	46.7	54.0	7.3	Complied

**Transmitter Band Edge Radiated Emissions (continued)**

**Results: 802.11b / 20 MHz / DQPSK / 2 Mbps / DAC 0**

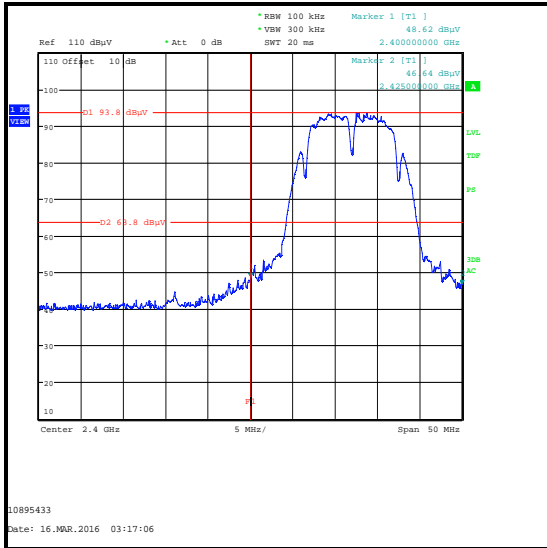

**Lower Band Edge Peak Measurement**

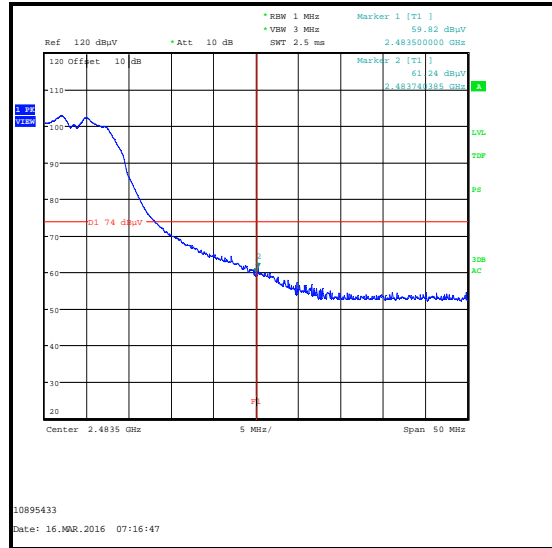

**Upper Band Edge Peak Measurement**

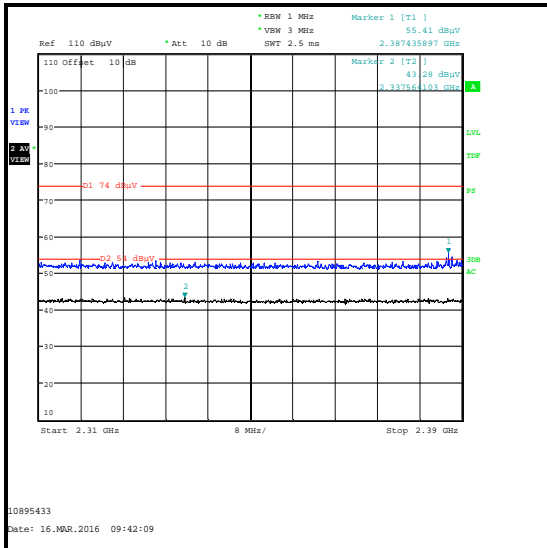

**2310 MHz to 2390 MHz Restricted Band Plot**

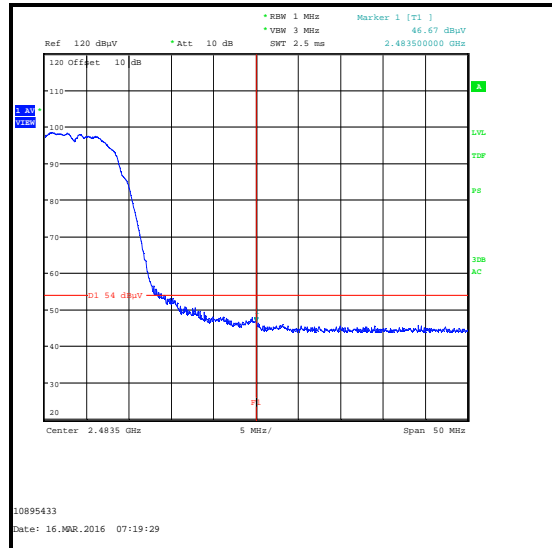

**Upper Band Edge Average Measurement**

**Transmitter Band Edge Radiated Emissions (continued)****Results: 802.11g / 20 MHz / SISO / BPSK / 6 Mbps / DAC 0****Results: Lower Band Edge**

Frequency (MHz)	Level (dB $\mu$ V/m)	-30 dBc Limit (dB $\mu$ V/m)	Margin (dB)	Result
2399.279	56.5	63.2	6.7	Complied
2400	54.4	63.2	8.8	Complied

**Results: Upper Band Edge / Restricted Band / Peak**

Frequency (MHz)	Level (dB $\mu$ V/m)	Limit (dB $\mu$ V/m)	Margin (dB)	Result
2389.744	56.5	74.0	17.5	Complied
2483.5	63.1	74.0	10.9	Complied

**Results: Upper Band Edge / Restricted Band / Average**

Frequency (MHz)	Level (dB $\mu$ V/m)	Limit (dB $\mu$ V/m)	Margin (dB)	Result
2390.000	45.5	54.0	8.5	Complied
2483.5	49.2	54.0	4.8	Complied

### Transmitter Band Edge Radiated Emissions (continued)

**Results: 802.11g / 20 MHz / SISO / BPSK / 6 Mbps / DAC 0**

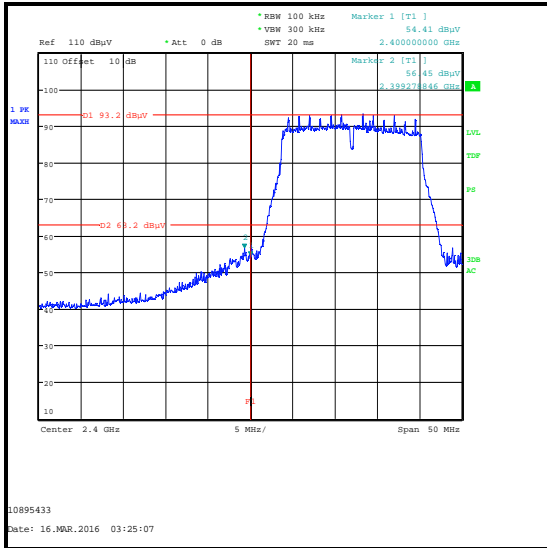

Lower Band Edge Peak Measurement

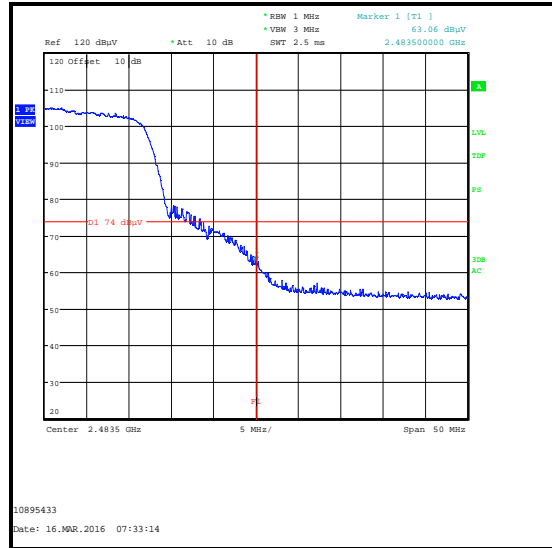

Upper Band Edge Peak Measurement

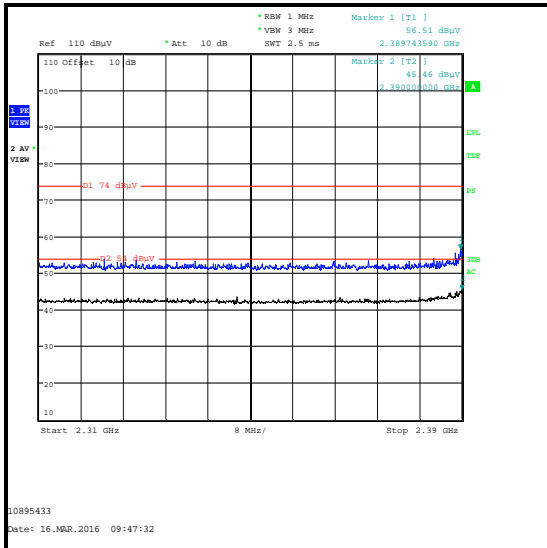

2310 MHz to 2390 MHz Restricted Band Plot

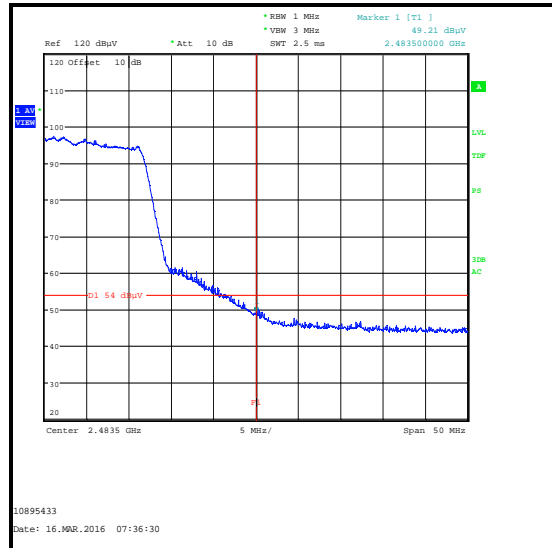

Upper Band Edge Average Measurement

**Transmitter Band Edge Radiated Emissions (continued)****Results: 802.11g / 20 MHz / CDD1 / BPSK / 6Mbps****Results: Lower Band Edge**

Frequency (MHz)	Level (dB $\mu$ V/m)	-30 dBc Limit (dB $\mu$ V/m)	Margin (dB)	Result
2399.519	57.0	62.5	5.5	Complied
2400	55.0	62.5	7.5	Complied

**Results: Upper Band Edge / Restricted Band / Peak**

Frequency (MHz)	Level (dB $\mu$ V/m)	Limit (dB $\mu$ V/m)	Margin (dB)	Result
2389.487	55.3	74.0	18.7	Complied
2483.5	55.8	74.0	18.2	Complied
2483.901	56.2	74.0	17.8	Complied

**Results: Upper Band Edge / Restricted Band / Average**

Frequency (MHz)	Level (dB $\mu$ V/m)	Limit (dB $\mu$ V/m)	Margin (dB)	Result
2390.000	44.2	54.0	9.8	Complied
2483.5	47.2	54.0	6.8	Complied



### Transmitter Band Edge Radiated Emissions (continued)

Results: 802.11g / 20 MHz / CDD1 / BPSK / 6 Mbps

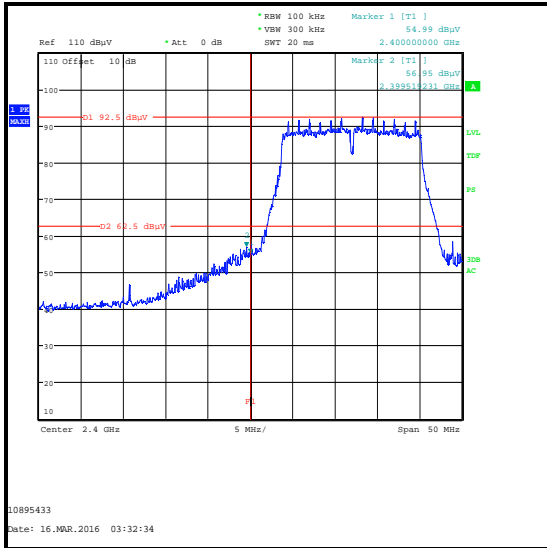

Lower Band Edge Peak Measurement

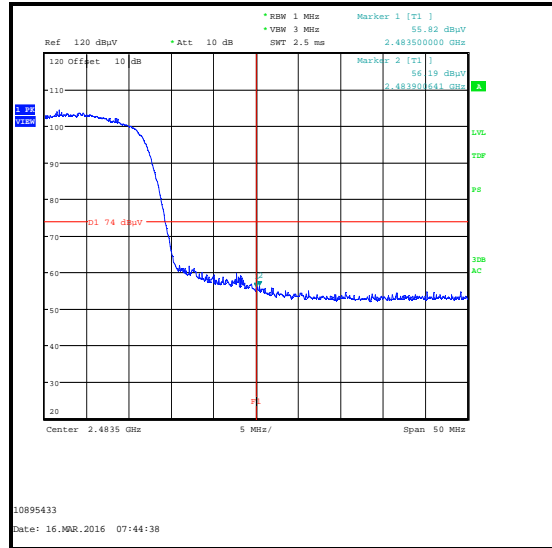

Upper Band Edge Peak Measurement

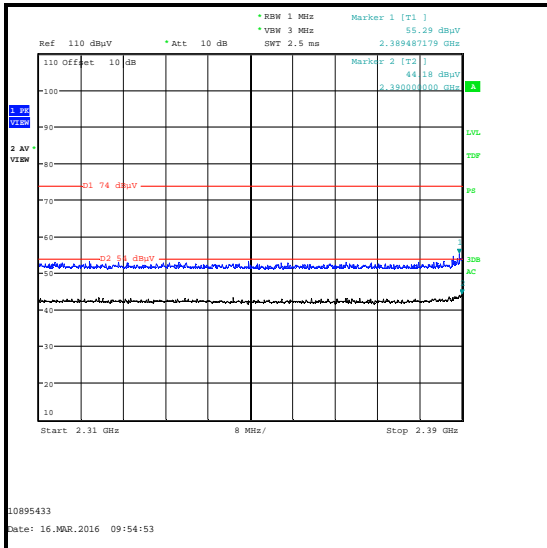

2310 MHz to 2390 MHz Restricted Band Plot

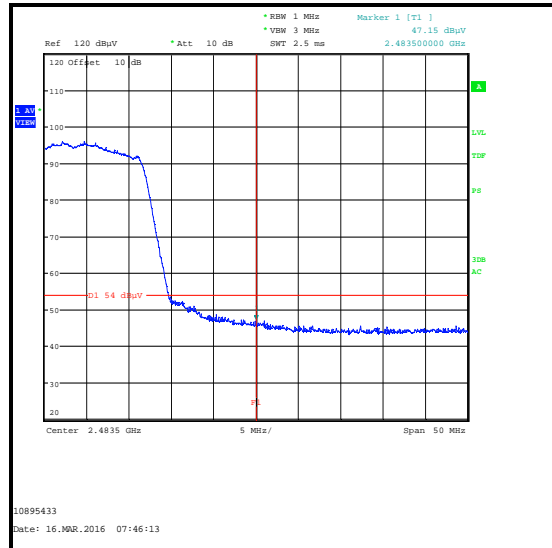

Upper Band Edge Average Measurement

**Transmitter Band Edge Radiated Emissions (continued)****Results: 802.11n HT20 / SISO / QPSK / MCS1****Results: Lower Band Edge**

Frequency (MHz)	Level (dB $\mu$ V/m)	-30 dBc Limit (dB $\mu$ V/m)	Margin (dB)	Result
2399.519	53.3	62.5	9.2	Complied
2400	52.4	62.5	10.1	Complied

**Results: Upper Band Edge / Restricted Band / Peak**

Frequency (MHz)	Level (dB $\mu$ V/m)	Limit (dB $\mu$ V/m)	Margin (dB)	Result
2389.744	55.3	74.0	18.7	Complied
2483.5	65.5	74.0	8.5	Complied

**Results: Upper Band Edge / Restricted Band / Average**

Frequency (MHz)	Level (dB $\mu$ V/m)	Limit (dB $\mu$ V/m)	Margin (dB)	Result
2389.872	44.8	54.0	9.2	Complied
2483.5	49.6	54.0	4.4	Complied
2483.580	50.1	54.0	3.9	Complied

### Transmitter Band Edge Radiated Emissions (continued)

#### Results: 802.11n HT20 / SISO / QPSK / MCS1

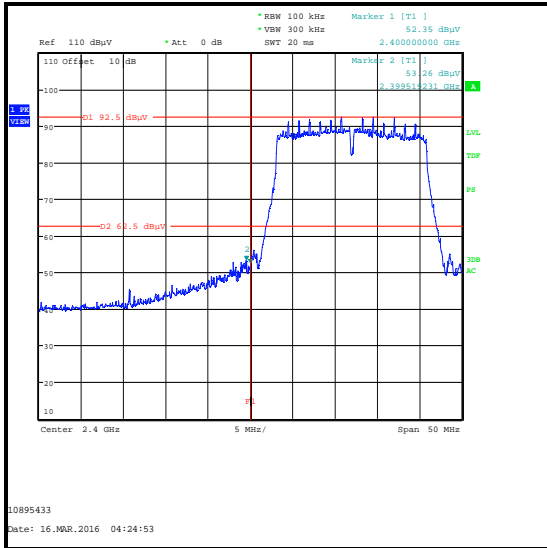

Lower Band Edge Peak Measurement

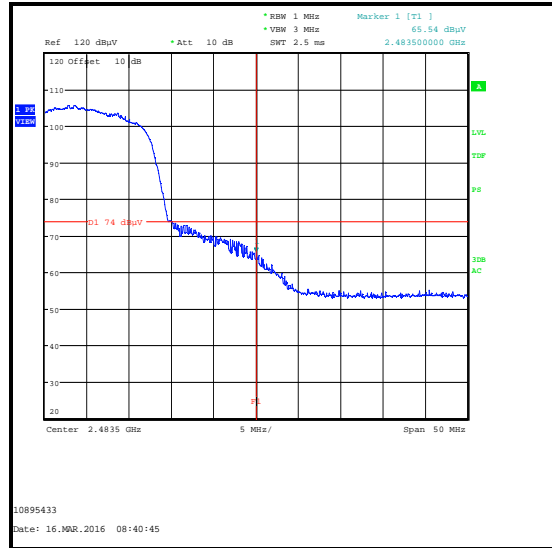

Upper Band Edge Peak Measurement

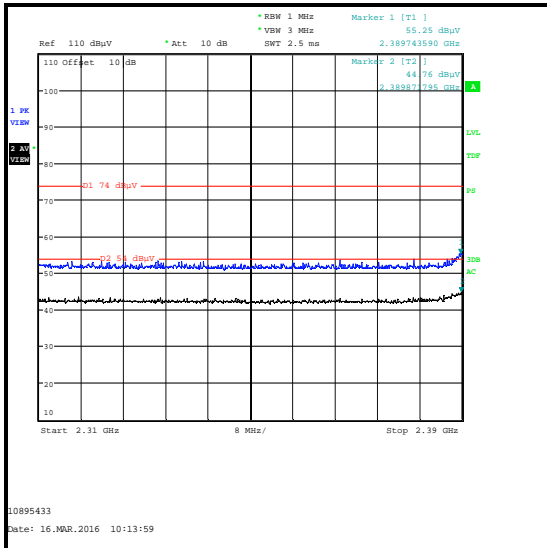

2310 MHz to 2390 MHz Restricted Band Plot

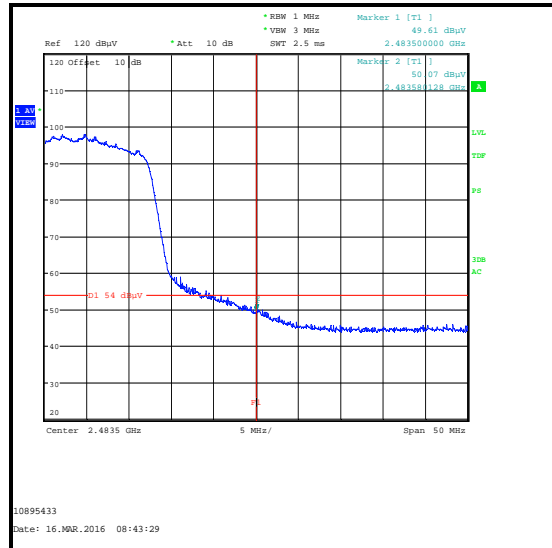

Upper Band Edge Average Measurement

**Transmitter Band Edge Radiated Emissions (continued)****Results: 802.11n HT20 / SISO / 16QAM / MCS4****Results: Lower Band Edge**

Frequency (MHz)	Level (dB $\mu$ V/m)	-30 dBc Limit (dB $\mu$ V/m)	Margin (dB)	Result
2396.955	51.9	61.0	9.1	Complied
2400	48.9	61.0	12.1	Complied

**Results: Upper Band Edge / Restricted Band / Peak**

Frequency (MHz)	Level (dB $\mu$ V/m)	Limit (dB $\mu$ V/m)	Margin (dB)	Result
2390.000	53.8	74.0	20.2	Complied
2483.5	59.6	74.0	14.4	Complied
2484.221	61.1	74.0	12.9	Complied

**Results: Upper Band Edge / Restricted Band / Average**

Frequency (MHz)	Level (dB $\mu$ V/m)	Limit (dB $\mu$ V/m)	Margin (dB)	Result
2315.128	43.6	54.0	10.4	Complied
2483.5	52.8	54.0	1.2	Complied

### Transmitter Band Edge Radiated Emissions (continued)

#### Results: 802.11n HT20 / SISO / 16QAM / MCS4

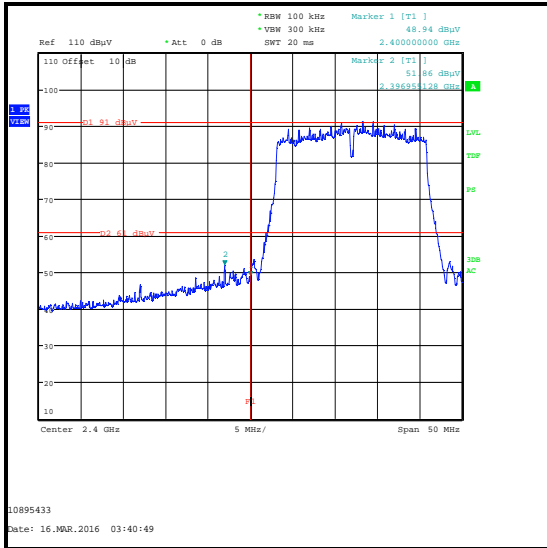

Lower Band Edge Peak Measurement

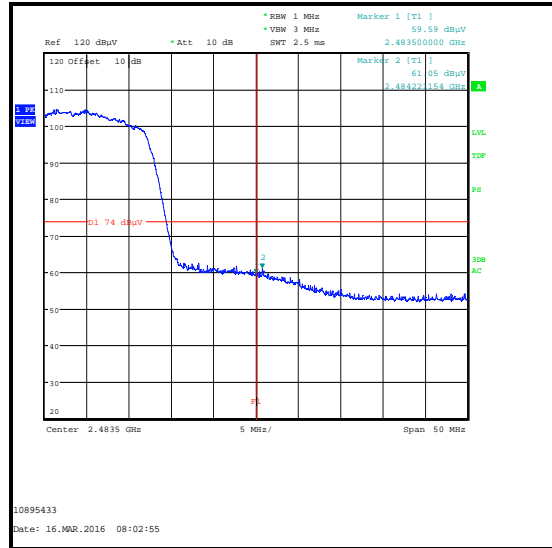

Upper Band Edge Peak Measurement

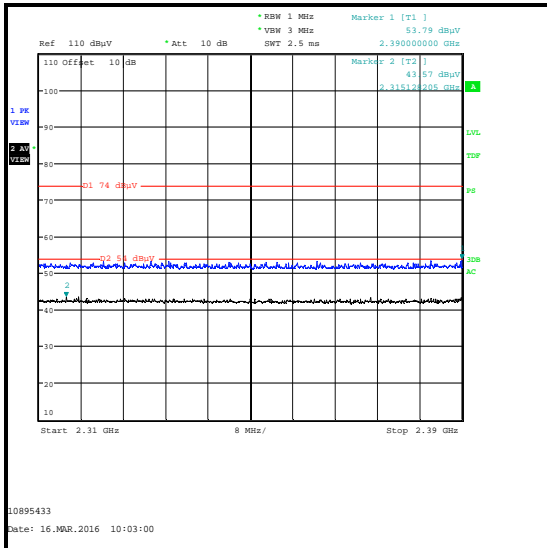

2310 MHz to 2390 MHz Restricted Band Plot

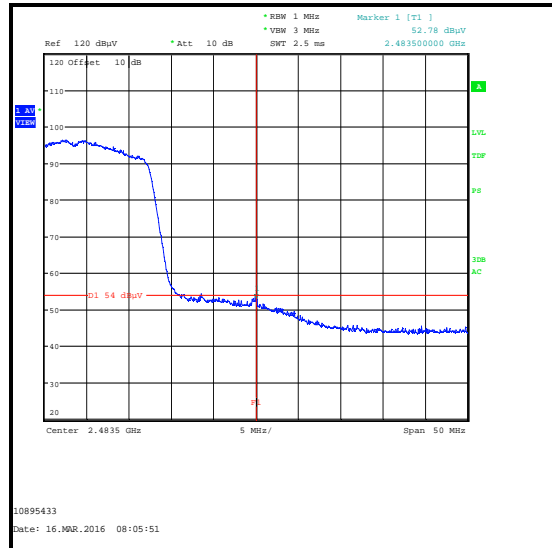

Upper Band Edge Average Measurement

**Transmitter Band Edge Radiated Emissions (continued)****Results: 802.11n HT20 / CDD1 / BPSK / MCS0****Results: Lower Band Edge**

Frequency (MHz)	Level (dB $\mu$ V/m)	-30 dBc Limit (dB $\mu$ V/m)	Margin (dB)	Result
2399.760	54.1	61.9	7.8	Complied
2400	53.2	61.9	8.7	Complied

**Results: Upper Band Edge / Restricted Band / Peak**

Frequency (MHz)	Level (dB $\mu$ V/m)	Limit (dB $\mu$ V/m)	Margin (dB)	Result
2389.615	57.7	74.0	16.3	Complied
2483.5	61.1	74.0	12.9	Complied

**Results: Upper Band Edge / Restricted Band / Average**

Frequency (MHz)	Level (dB $\mu$ V/m)	Limit (dB $\mu$ V/m)	Margin (dB)	Result
2389.231	44.3	54.0	9.7	Complied
2483.5	47.7	54.0	6.3	Complied
2483.660	48.4	54.0	5.6	Complied

### Transmitter Band Edge Radiated Emissions (continued)

#### Results: 802.11n HT20 / CDD1 / BPSK / MCS0

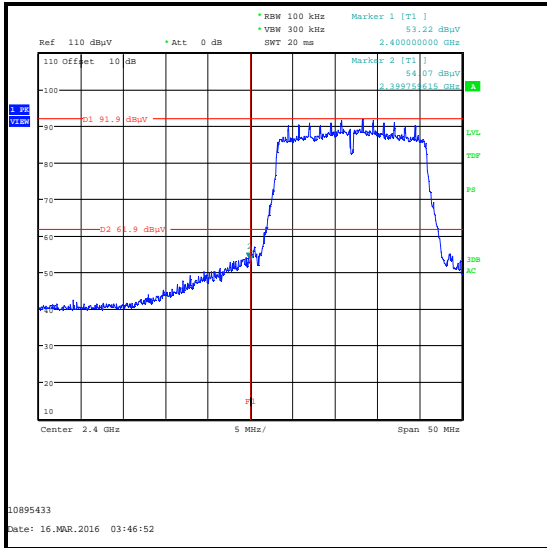

Lower Band Edge Peak Measurement

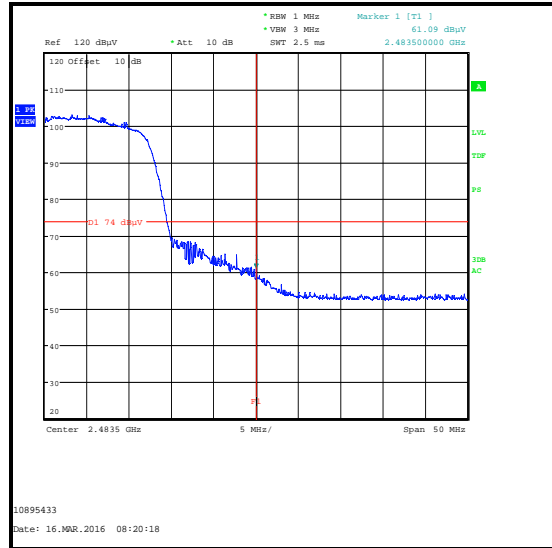

Upper Band Edge Peak Measurement

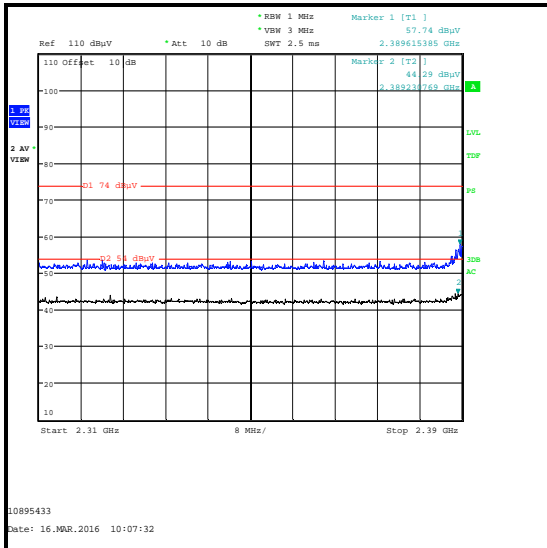

2310 MHz to 2390 MHz Restricted Band Plot

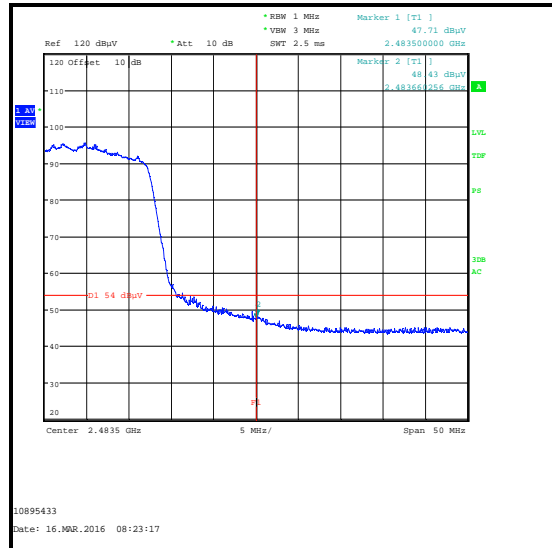

Upper Band Edge Average Measurement

**Transmitter Band Edge Radiated Emissions (continued)****Results: 802.11n / HT40 / SISO / BPSK / MCS0****Results: Lower Band Edge**

Frequency (MHz)	Level (dB $\mu$ V/m)	-30 dBc Limit (dB $\mu$ V/m)	Margin (dB)	Result
2399.119	56.7	62.8	6.1	Complied
2400	55.0	62.8	7.8	Complied

**Results: Upper Band Edge / Restricted Band / Peak**

Frequency (MHz)	Level (dB $\mu$ V/m)	Limit (dB $\mu$ V/m)	Margin (dB)	Result
2390.000	66.9	74.0	7.1	Complied
2483.5	62.7	74.0	11.3	Complied
2484.061	63.0	74.0	11.0	Complied

**Results: Upper Band Edge / Restricted Band / Average**

Frequency (MHz)	Level (dB $\mu$ V/m)	Limit (dB $\mu$ V/m)	Margin (dB)	Result
2385.641	53.7	54.0	0.3	Complied
2483.5	53.0	54.0	1.0	Complied



### Transmitter Band Edge Radiated Emissions (continued)

#### Results: 802.11n / HT40 / SISO / BPSK / MCS0

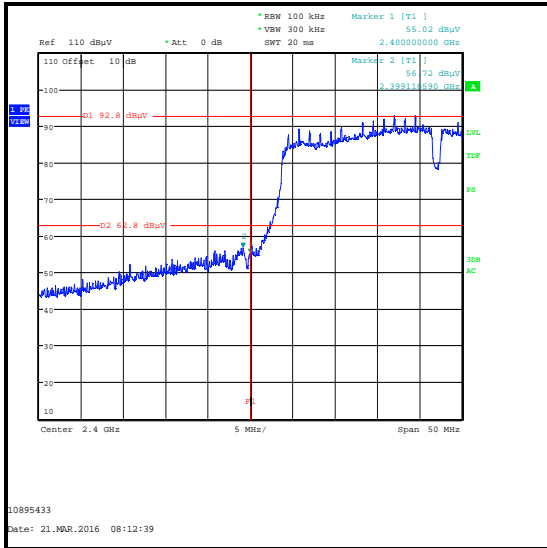

Lower Band Edge Peak Measurement

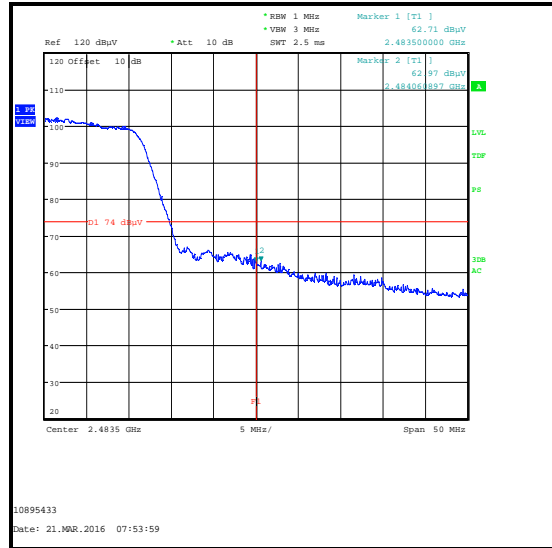

Upper Band Edge Peak Measurement

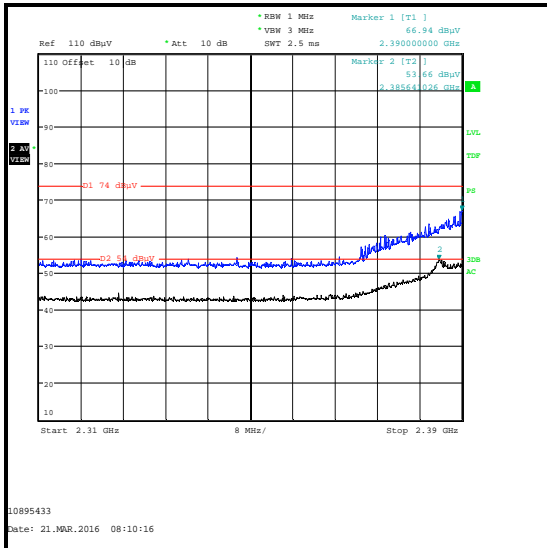

2310 MHz to 2390 MHz Restricted Band Plot

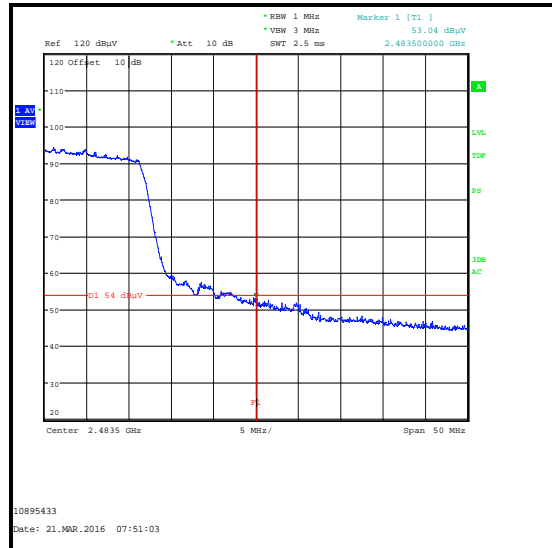

Upper Band Edge Average Measurement

**Transmitter Band Edge Radiated Emissions (continued)****Results: 802.11n / HT40 / SISO / 16QAM / MCS4****Results: Lower Band Edge**

Frequency (MHz)	Level (dB $\mu$ V/m)	-30 dBc Limit (dB $\mu$ V/m)	Margin (dB)	Result
2399.439	56.9	62.2	5.3	Complied
2400	54.9	62.2	7.3	Complied

**Results: Upper Band Edge / Restricted Band / Peak**

Frequency (MHz)	Level (dB $\mu$ V/m)	Limit (dB $\mu$ V/m)	Margin (dB)	Result
2387.692	59.7	74.0	14.3	Complied
2483.5	58.9	74.0	15.1	Complied
2484.542	60.2	74.0	13.8	Complied

**Results: Upper Band Edge / Restricted Band / Average**

Frequency (MHz)	Level (dB $\mu$ V/m)	Limit (dB $\mu$ V/m)	Margin (dB)	Result
2384.487	52.1	54.0	1.9	Complied
2483.5	49.7	54.0	4.3	Complied
2485.904	50.7	54.0	3.3	Complied

**Transmitter Band Edge Radiated Emissions (continued)**

**Results: 802.11n / HT40 / SISO / 16QAM / MCS4**

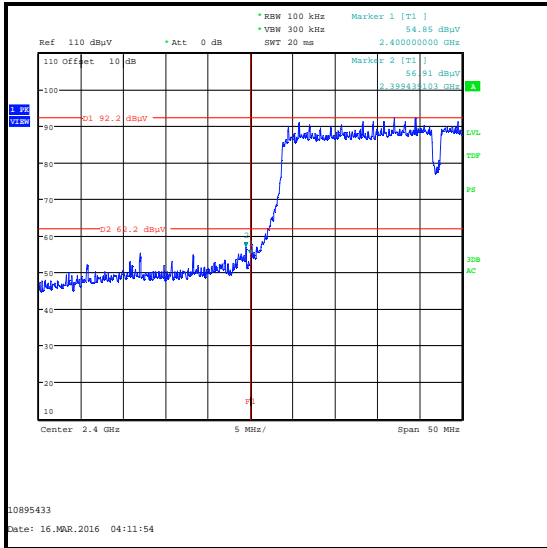

**Lower Band Edge Peak Measurement**

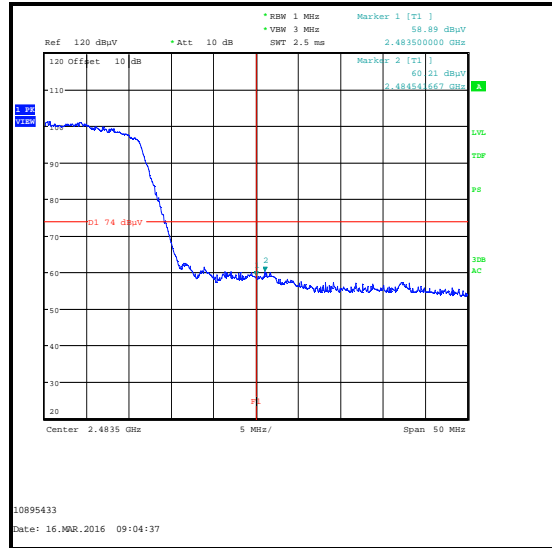

**Upper Band Edge Peak Measurement**

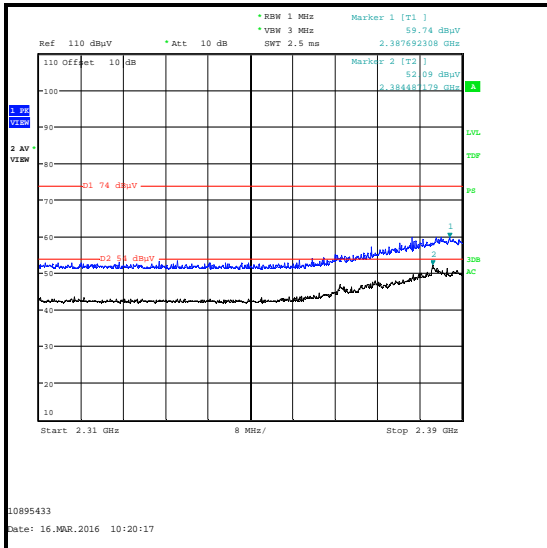

**2310 MHz to 2390 MHz Restricted Band Plot**

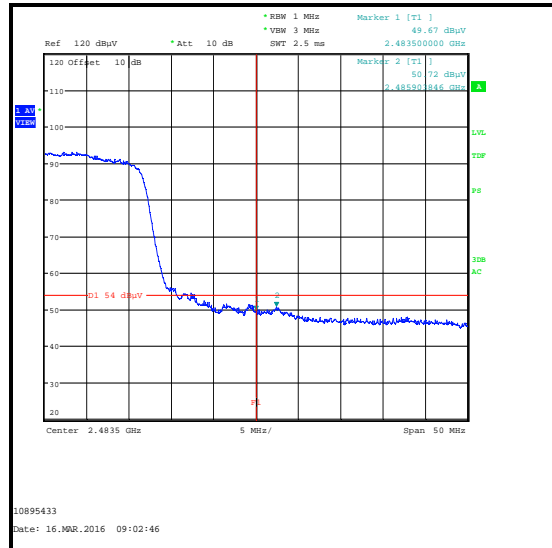

**Upper Band Edge Average Measurement**

**Transmitter Band Edge Radiated Emissions (continued)****Results: 802.11n / HT40 / CDD1 / BPSK / MCS0****Results: Lower Band Edge**

Frequency (MHz)	Level (dB $\mu$ V/m)	-30 dBc Limit (dB $\mu$ V/m)	Margin (dB)	Result
2398.558	53.2	61.5	8.3	Complied
2400	52.3	61.5	9.2	Complied

**Results: Upper Band Edge / Restricted Band / Peak**

Frequency (MHz)	Level (dB $\mu$ V/m)	Limit (dB $\mu$ V/m)	Margin (dB)	Result
2383.718	62.9	74.0	11.1	Complied
2483.5	62.0	74.0	12.0	Complied
2484.862	63.3	74.0	10.7	Complied

**Results: Upper Band Edge / Restricted Band / Average**

Frequency (MHz)	Level (dB $\mu$ V/m)	Limit (dB $\mu$ V/m)	Margin (dB)	Result
2385.897	52.8	54.0	1.2	Complied
2483.5	51.2	54.0	2.8	Complied
2489.429	52.6	54.0	1.4	Complied

**Transmitter Band Edge Radiated Emissions (continued)**

**Results: 802.11n / HT40 / CDD1 / BPSK / MCS0**

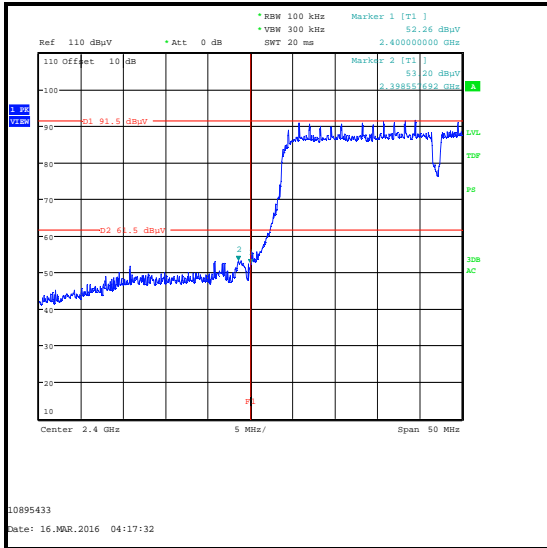

**Lower Band Edge Peak Measurement**

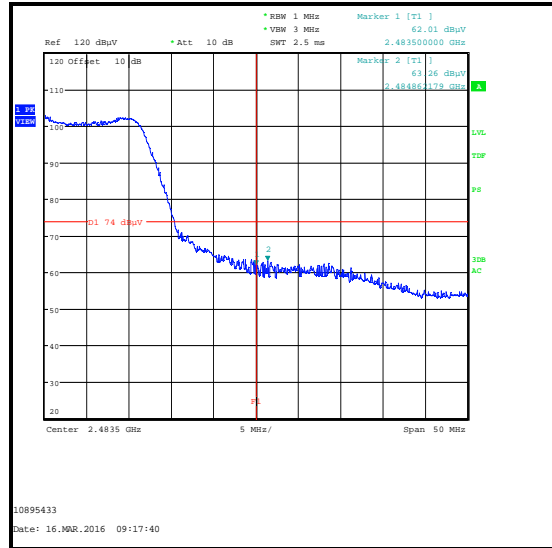

**Upper Band Edge Peak Measurement**

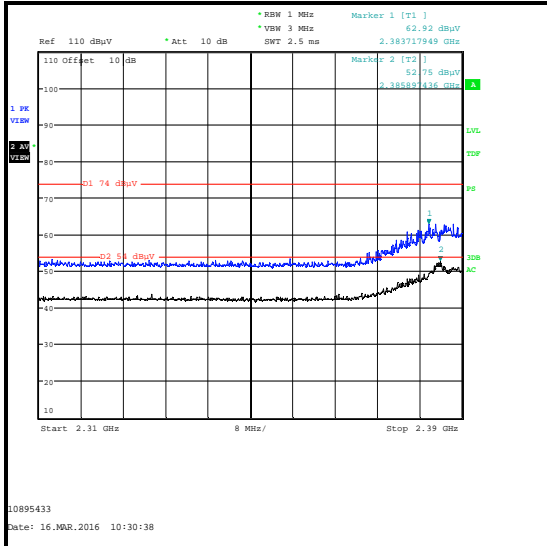

**2310 MHz to 2390 MHz Restricted Band Plot**

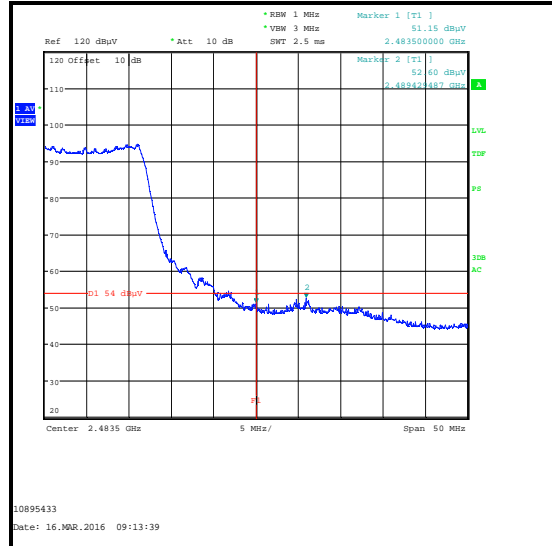

**Upper Band Edge Average Measurement**

**Test Equipment Used:**

Asset No.	Instrument	Manufacturer	Type No.	Serial No.	Date Calibration Due	Cal. Interval (Months)
M1656	Thermohyrometer	JM Handelpunkt	30.5015.13	None stated	23 Apr 2016	12
K0002	3m RSE Chamber	Rainford EMC	N/A	N/A	21 Dec 2016	12
M1874	Test Receiver	Rohde & Schwarz	ESU26	100553	12 Jun 2016	12
A1534	Pre Amplifier	Hewlett Packard	8449B	3008A00405	19 Dec 2016	12
A1818	Antenna	EMCO	3115	00075692	17 Dec 2016	12
A1396	Attenuator	Huber & Suhner	6810.17.B	757987	05 May 2016	12

## **6. Measurement Uncertainty**

No measurement or test can ever be perfect and the imperfections give rise to error of measurement in the results. Consequently the result of a measurement is only an approximation to the value of the measurand (the specific quantity subject to measurement) and is only complete when accompanied by a statement of the uncertainty of the approximation.

The expression of uncertainty of a measurement result allows realistic comparison of results with reference values and limits given in specifications and standards.

The uncertainty of the result may need to be taken into account when interpreting the measurement results.

The reported expanded uncertainties below are based on a standard uncertainty multiplied by an appropriate coverage factor such that a confidence level of approximately 95% is maintained. For the purposes of this document "approximately" is interpreted as meaning "effectively" or "for most practical purposes".

<b>Measurement Type</b>	<b>Range</b>	<b>Confidence Level (%)</b>	<b>Calculated Uncertainty</b>
AC Conducted Spurious Emissions	0.15 MHz to 30 MHz	95%	±4.69 dB
Minimum 6 dB Bandwidth	2.4 GHz to 2.4835 GHz	95%	±4.59 %
Duty Cycle	2.4 GHz to 2.4835 GHz	95%	±1.14 %
Spectral Power Density	2.4 GHz to 2.4835 GHz	95%	±1.13 dB
Conducted Maximum Output Power	2.4 GHz to 2.4835 GHz	95%	±1.13 dB
Radiated Spurious Emissions	30 MHz to 1 GHz	95%	±5.65 dB
Radiated Spurious Emissions	1 GHz to 26.5 GHz	95%	±2.94 dB

The methods used to calculate the above uncertainties are in line with those recommended within the various measurement specifications. Where measurement specifications do not include guidelines for the evaluation of measurement uncertainty the published guidance of the appropriate accreditation body is followed.

## **7. Report Revision History**

Version Number	Revision Details		
	Page No(s)	Clause	Details
1.0	-	-	Initial Version
2.0	-	-	Model Number updated, Sections 3.1 and 5.2.2 updated

**--- END OF REPORT ---**