

Mid Channel

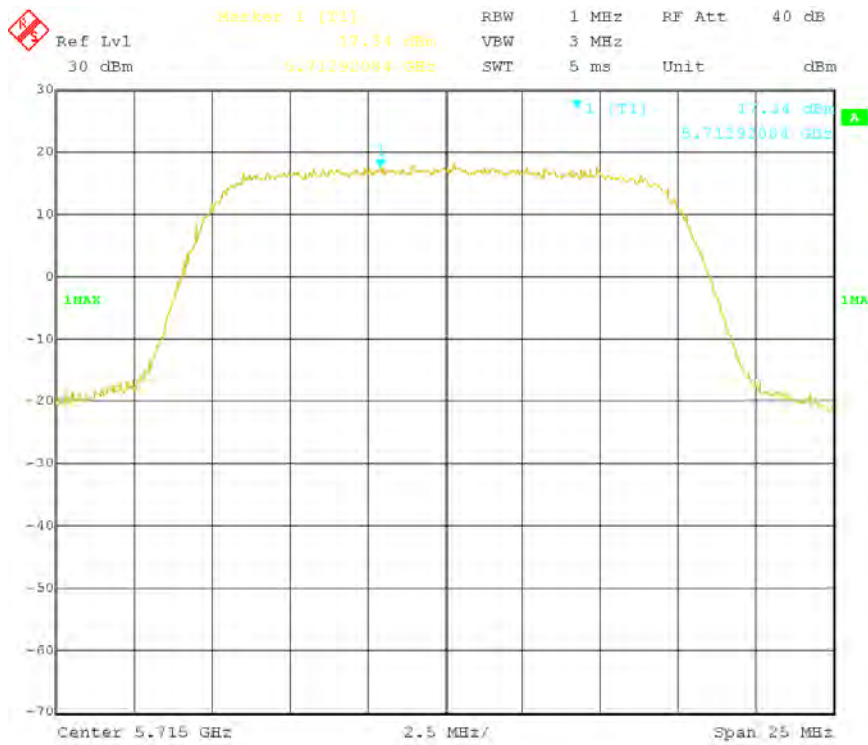

High Channel

Mode: 1 = QPSK, 32MHz Channel Bandwidth

Mode	Channel Bandwidth	Mode	Peak Max hold Spectrum (dBm)
Mode 3	16MHz	Low Channel	15.90
	16MHz	Mid Channel	16.10
	16MHz	High Channel	16.50

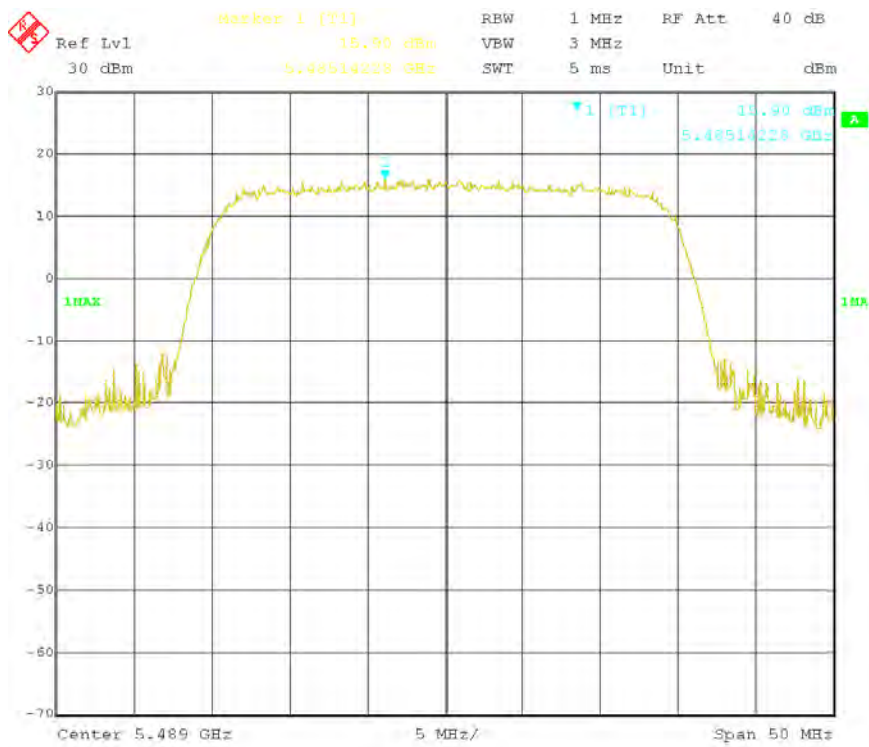

Low Channel

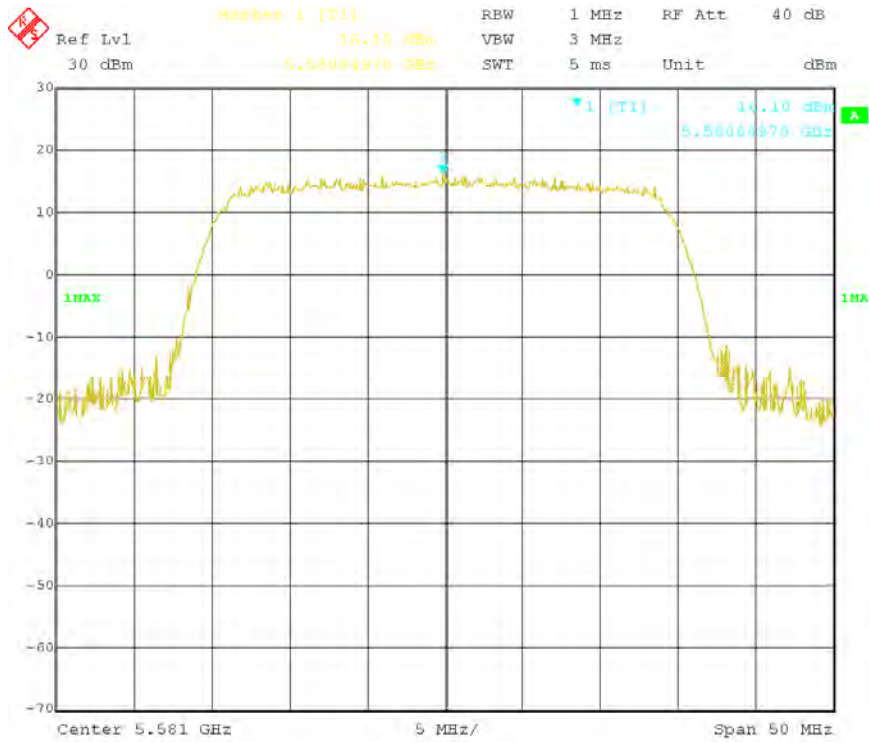

Mid Channel

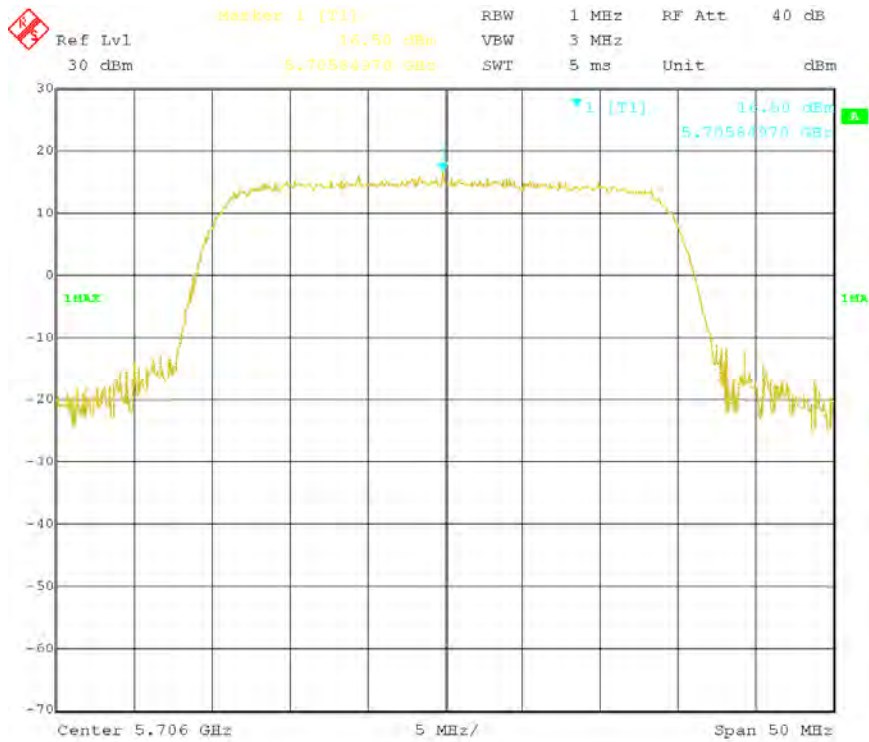

High Channel

Mode: 2 = 16QAM, 32MHz Channel Bandwidth

Mode	Channel Bandwidth	Mode	Peak Max hold Spectrum (dBm)
Mode 2	32MHz	Low Channel	17.23
	32MHz	Mid Channel	16.70
	32MHz	High Channel	15.61

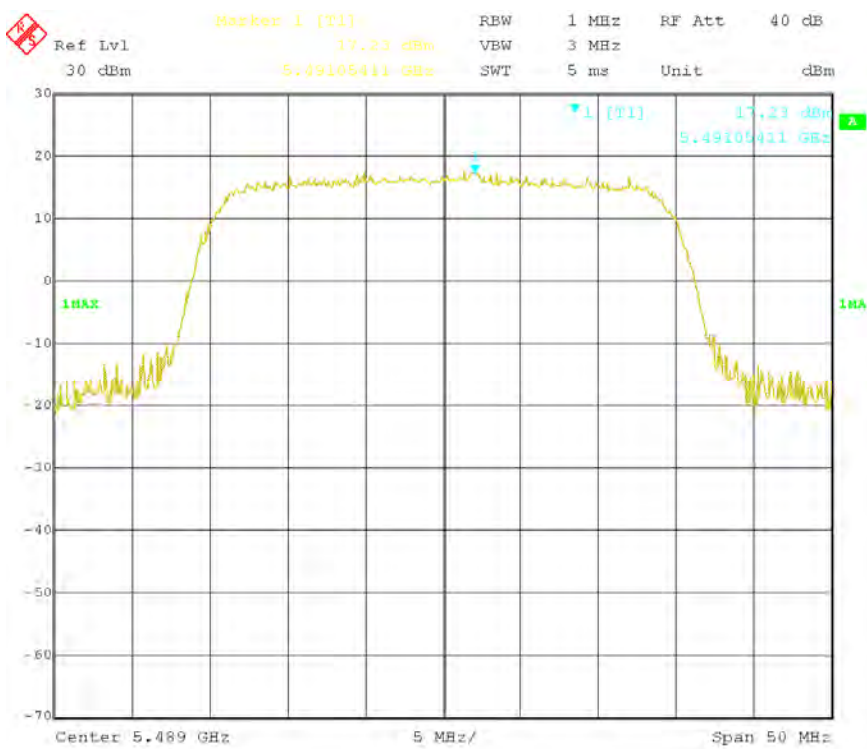

Low Channel

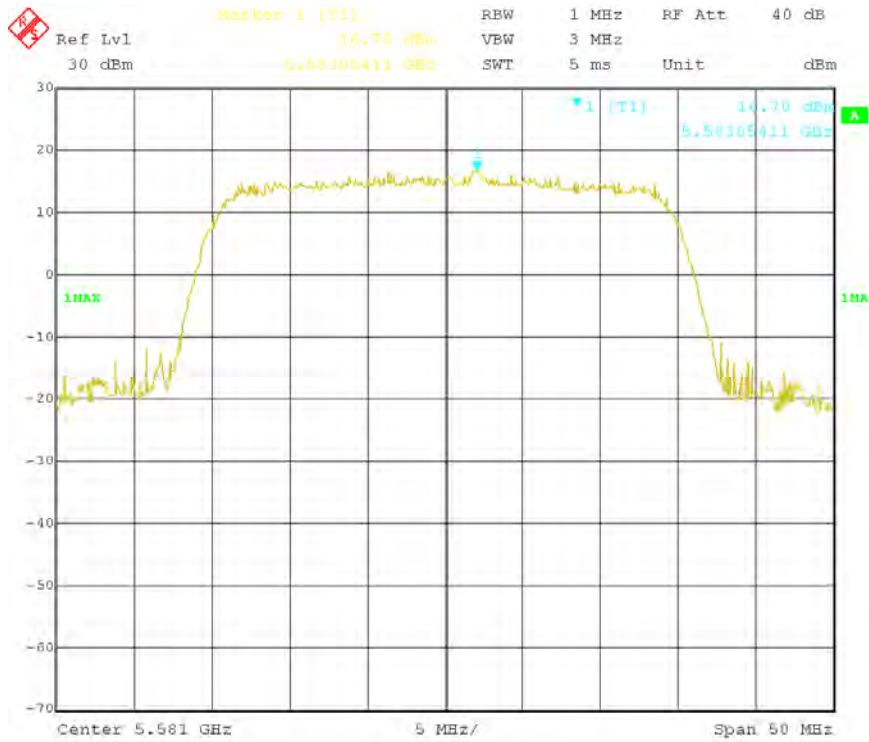

Mid Channel

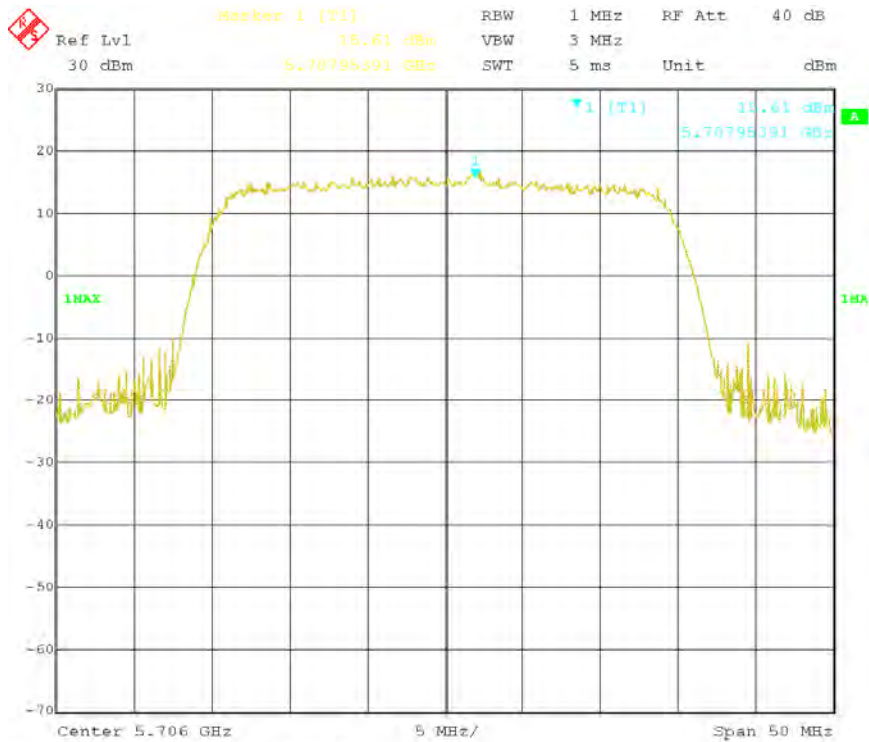

Date: 9.AUG.2012 17:14:17

High Channel

Mode: 3= 64QAM, 32MHz Channel Bandwidth

Mode	Channel Bandwidth	Mode	Peak Max hold Spectrum (dBm)
Mode 3	32MHz	Low Channel	15.10
	32MHz	Mid Channel	14.80
	32MHz	High Channel	14.68

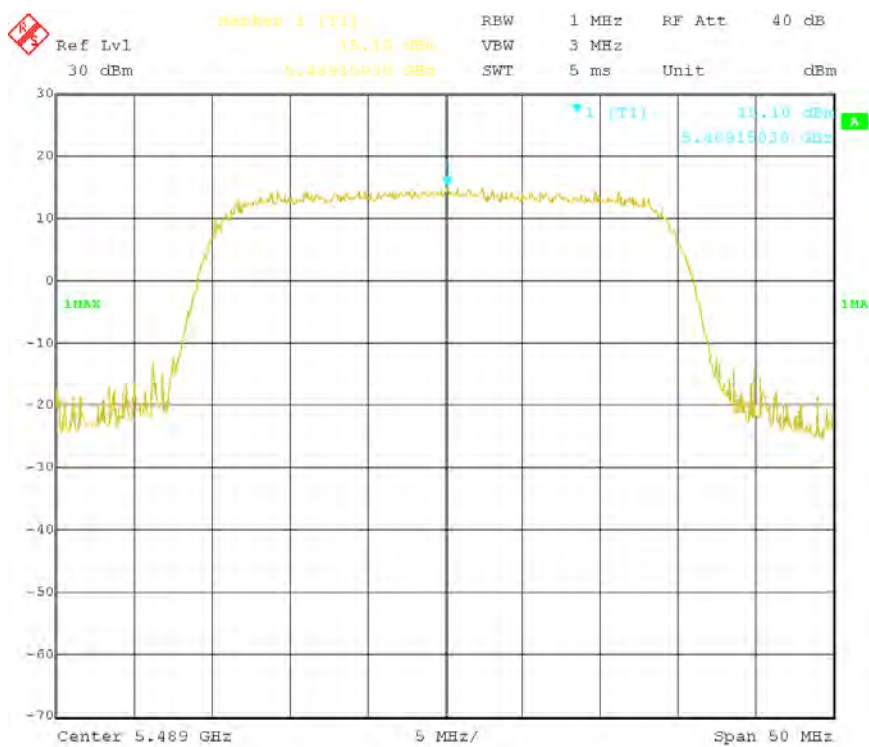

Low Channel

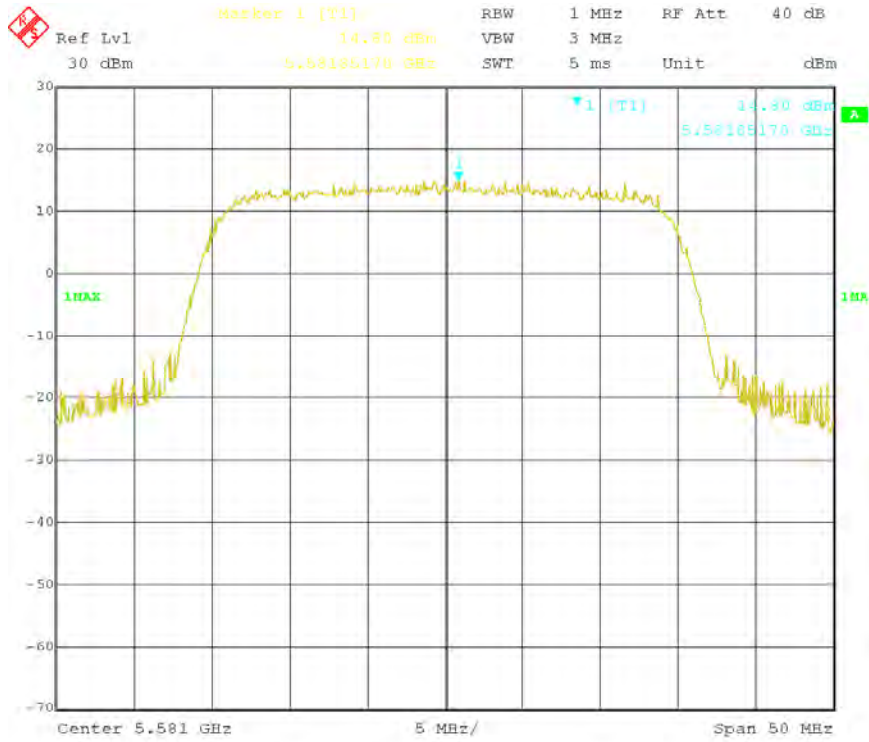

Mid Channel

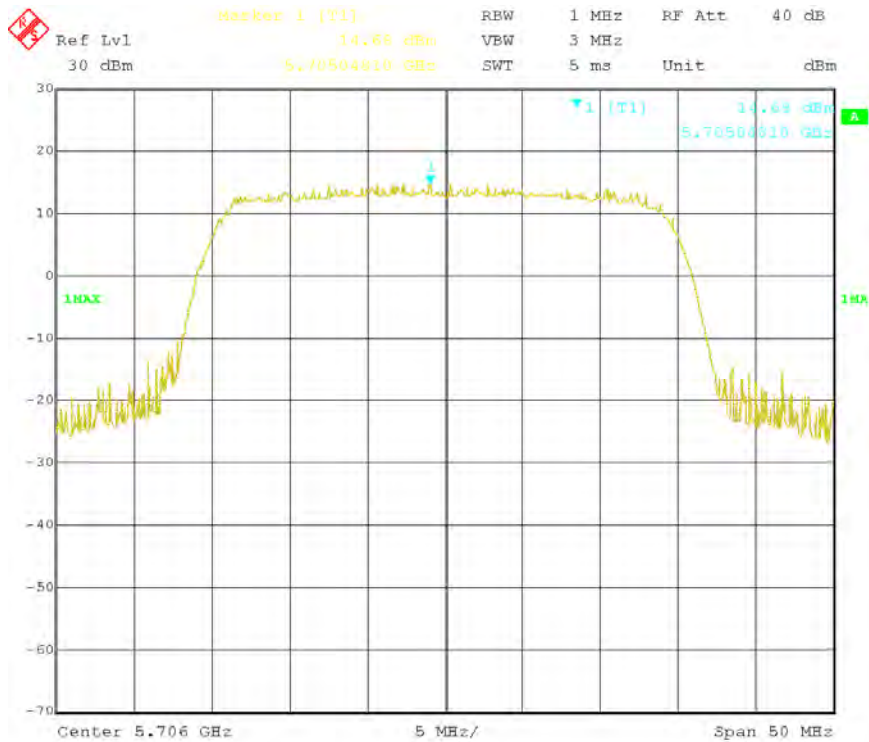

High Channel

5.5 Peak Output Power

1. Conducted Measurement
EUT was set for low , mid, high channel with modulated mode and highest RF output power.
The spectrum analyzer was connected to the antenna terminal.
2. Conducted Emissions Measurement Uncertainty
All test measurements carried out are traceable to national standards. The uncertainty of the measurement at a confidence level of approximately 95% (in the case where distributions are normal), with a coverage factor of 2, in the range 30MHz – 40GHz is ± 1.5 dB.
3. Environmental Conditions

Temperature	23°C
Relative Humidity	50%
Atmospheric Pressure	1019mbar
4. Test Date : August 01-15, 2012
Tested By : Choon Sian Ooi

Standard Requirement: 47 CFR §15.407(a); RSS210 (A9.2(2))

For the 5.25–5.35 GHz and 5.47–5.725 GHz bands, the maximum conducted output power over the frequency bands of operation shall not exceed the lesser of 250 mW or 11 dBm + 10 log B, where B is the 26 dB emission bandwidth in megahertz. In addition, the peak power spectral density shall not exceed 11 dBm in any 1 megahertz band. If transmitting antennas of directional gain greater than 6 dBi are used, both the maximum conducted output power and the peak power spectral density shall be reduced by the amount in dB that the directional gain of the antenna exceeds 6 dBi.

Procedures: KDB 789033 D01, Section C 3b, Method SA-1

Test Result:

Antenna	Antenna Gain	Bandwidth (MHz)	Antenna Gain >6dBi (Antenna Gain-6dBi)	Max Allowable Conducted Power (dBm)	Max EIRP (dBm)
Panel	29	8.63	23	20.36-22= -2.62	26.38
		17.42		23.41-22= 0.41	29.41
		33.88		24-22= 1.00	30.00
Parabolic Dish	37.9	8.63	31.9	20.36-31.5= -11.54	26.36
		17.42		23.41-31.5= -8.49	29.41
		33.88		24-31.5= -7.9	30.00

Note: Test plot is measured at Max conducted RF output power configuration when antenna gain is less than 6dBi. If higher gain antenna is used, power must be reduced to stated value on the table

5.2GHz Band

Mode: 1 = QPSK, 8MHz Channel Bandwidth

Mode	Channel Bandwidth	Mode	Power (dBm)
Mode 2	8MHz	Low Channel	20.12
	8MHz	Mid Channel	20.07
	8MHz	High Channel	19.99

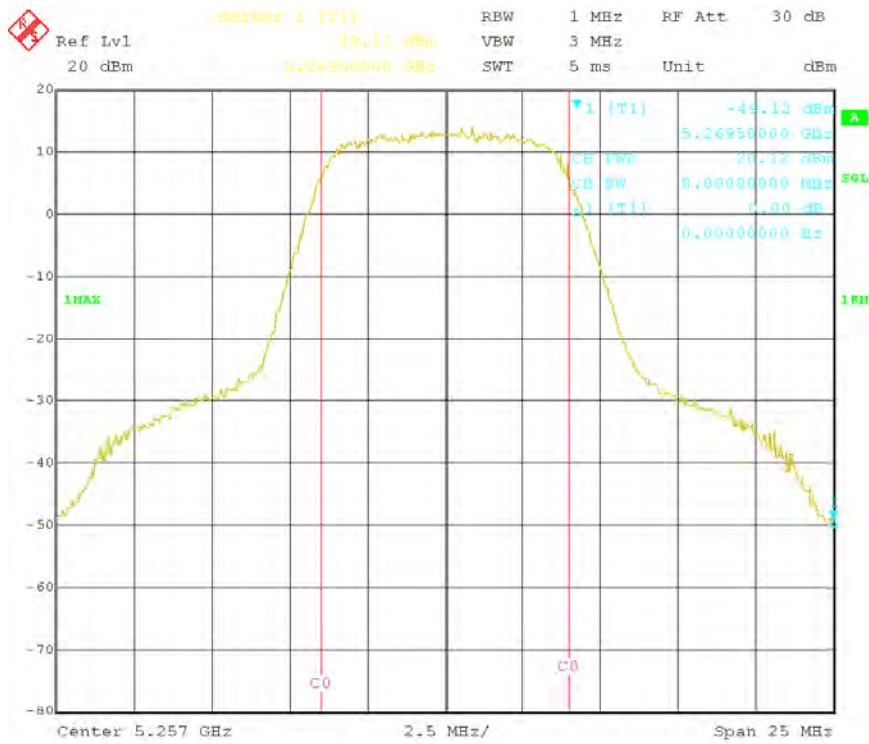

Low Channel

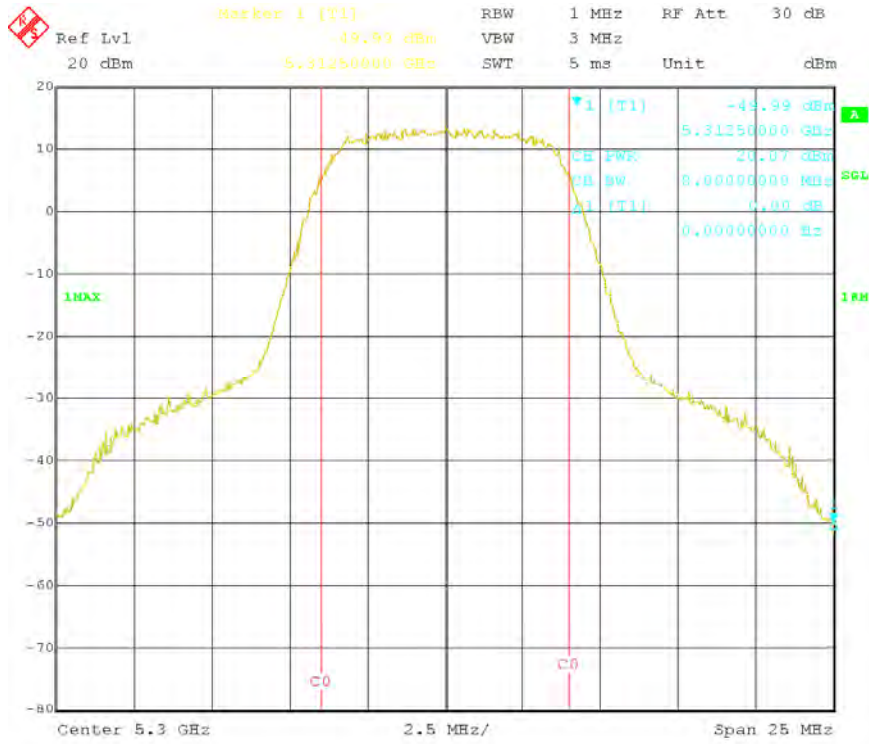

Mid Channel

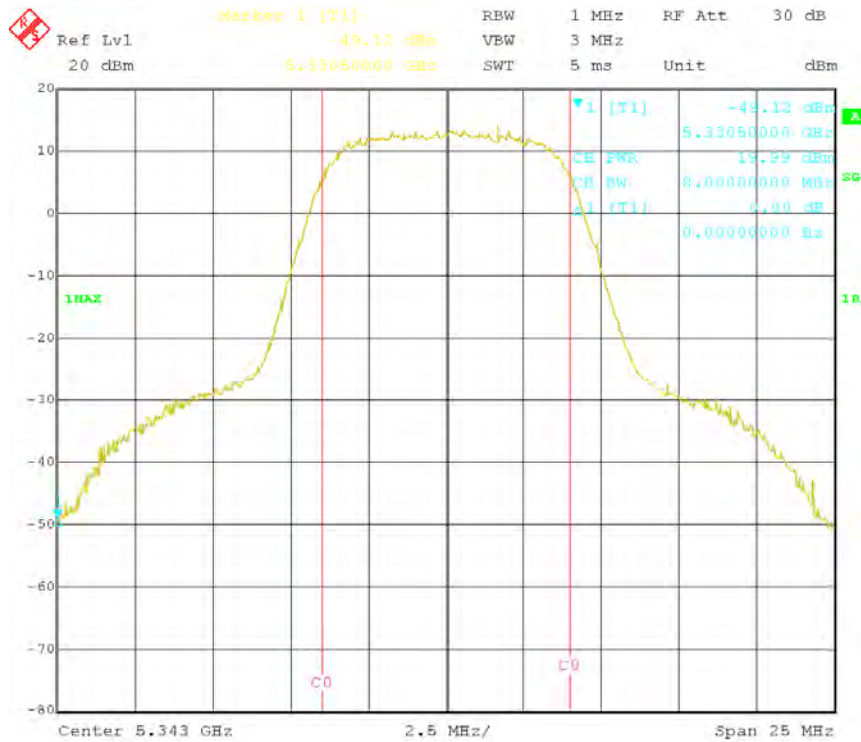

High Channel

Mode: 2 = 16QAM, 8MHz Channel Bandwidth

Mode	Channel Bandwidth	Mode	Power (dBm)
Mode 2	8MHz	Low Channel	20.03
	8MHz	Mid Channel	20.31
	8MHz	High Channel	20.72

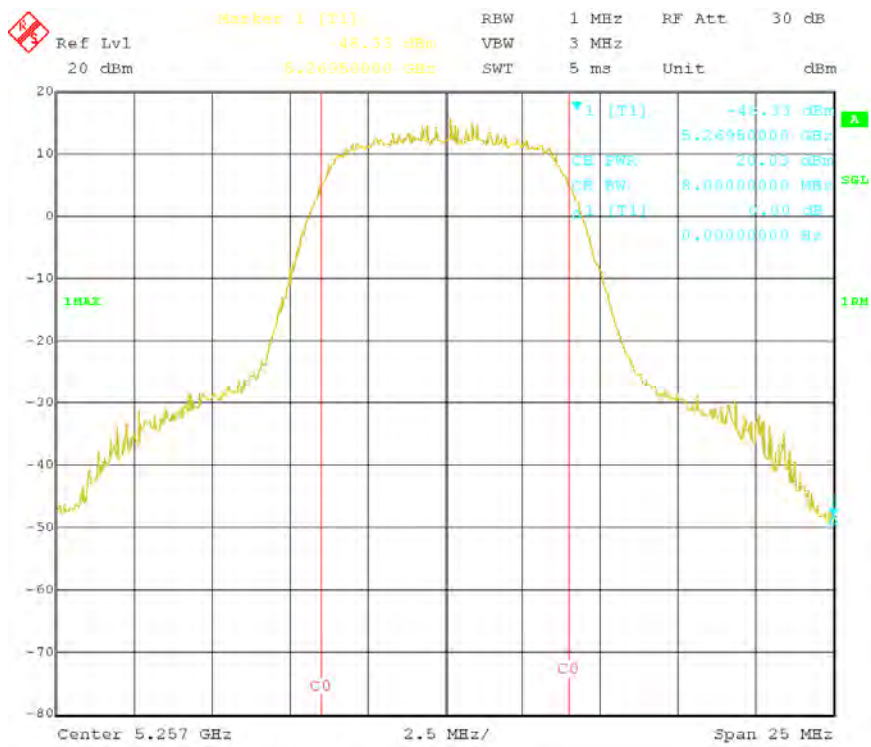

Low Channel

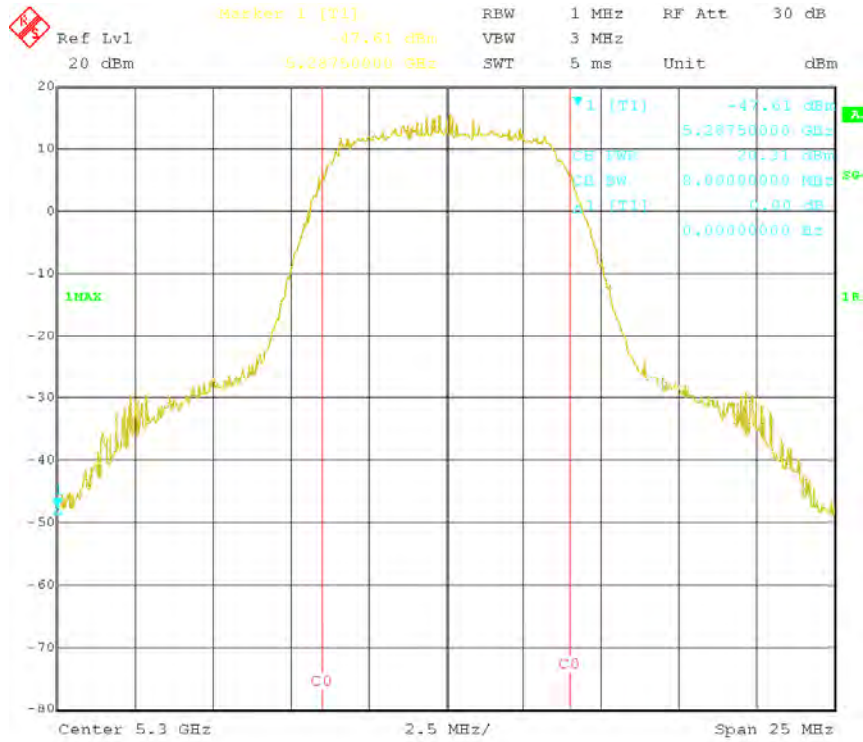

Mid Channel

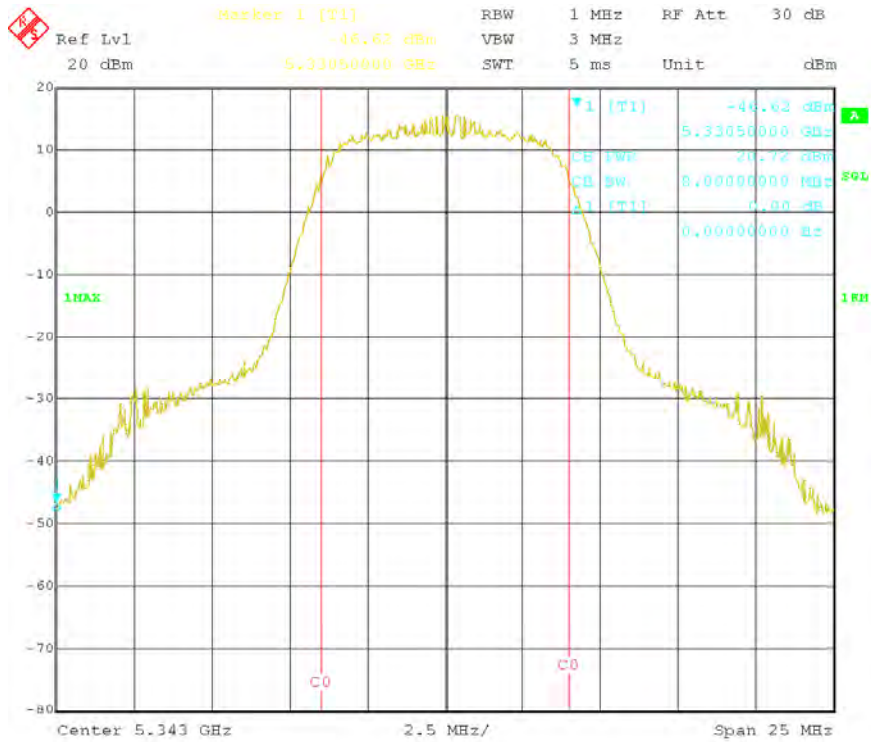

High Channel

Mode: 3 = 64QAM, 8MHz Channel Bandwidth

Mode	Channel Bandwidth	Mode	Power (dBm)
Mode 3	8MHz	Low Channel	18.97
	8MHz	Mid Channel	18.89
	8MHz	High Channel	18.96

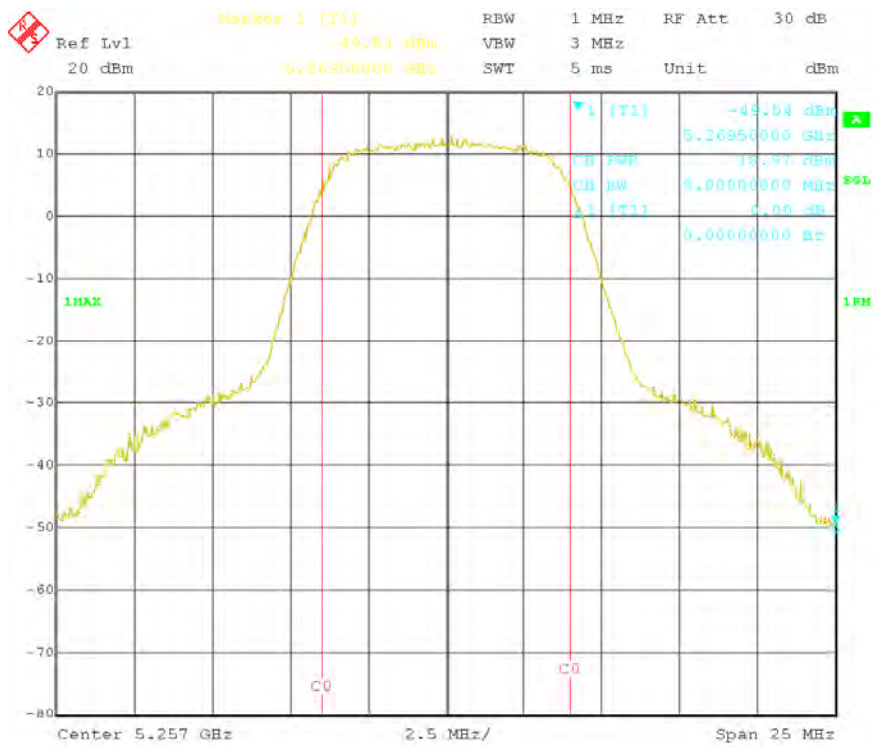

Low Channel

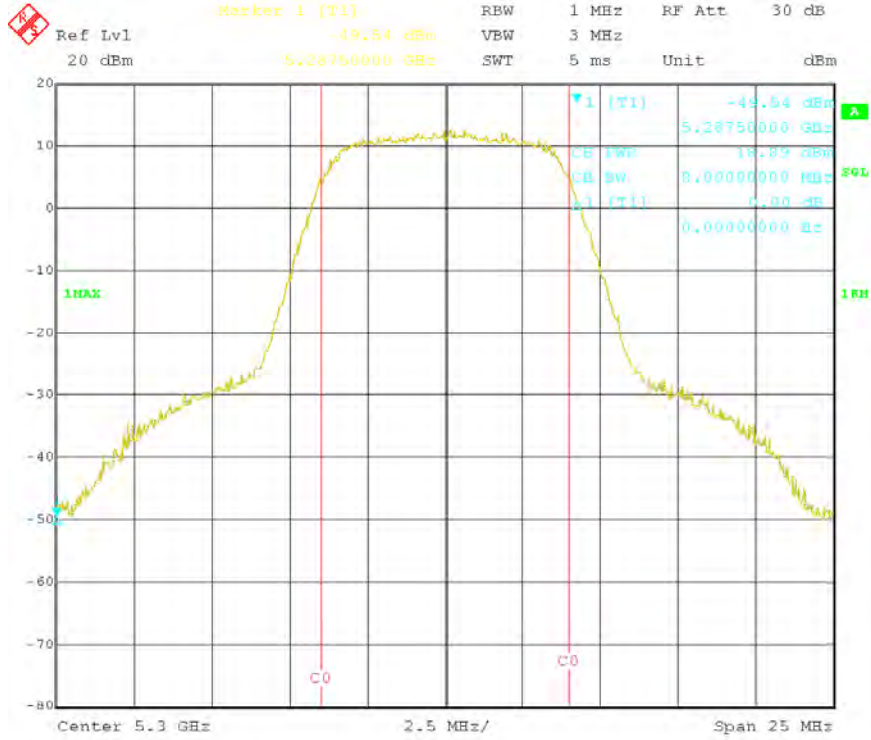

Mid Channel

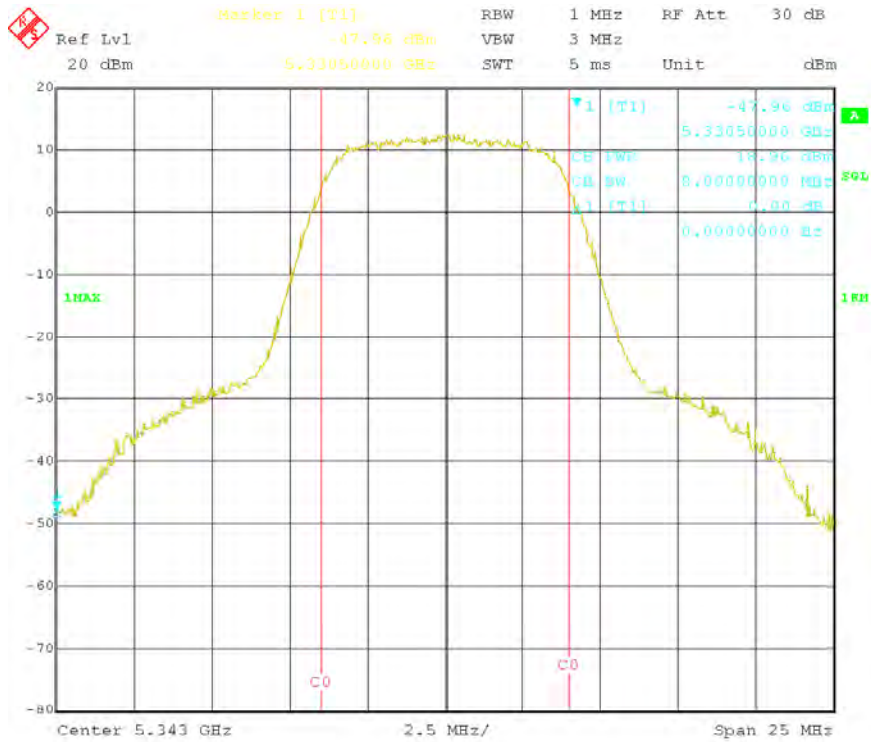

High Channel

Mode: 1 = QPSK, 16MHz Channel Bandwidth

Mode	Channel Bandwidth	Mode	Power (dBm)
Mode 1	16MHz	Low Channel	20.07
	16MHz	Mid Channel	20.06
	16MHz	High Channel	20.41

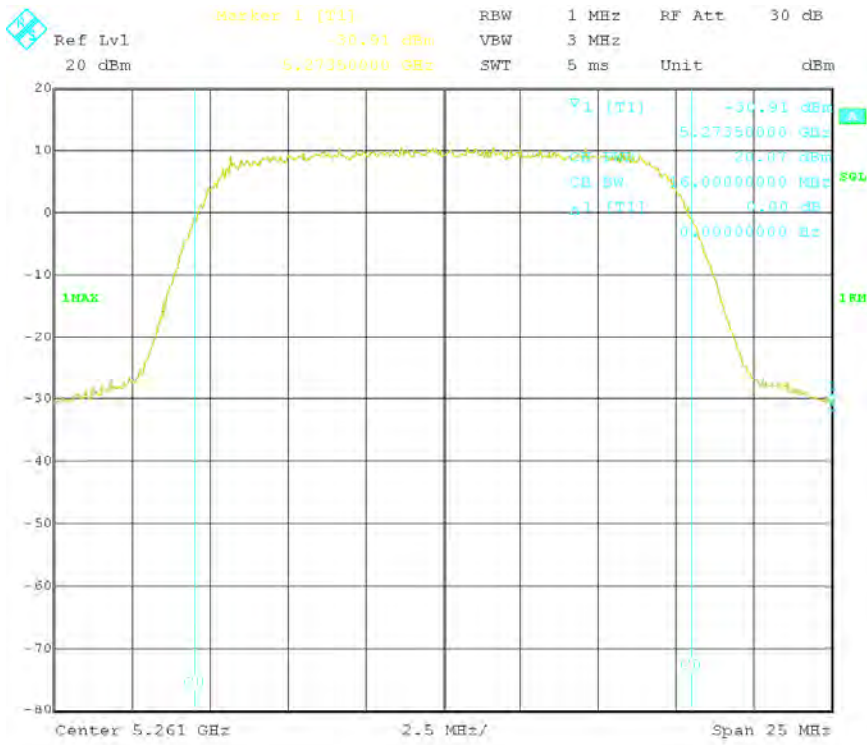

Low Channel

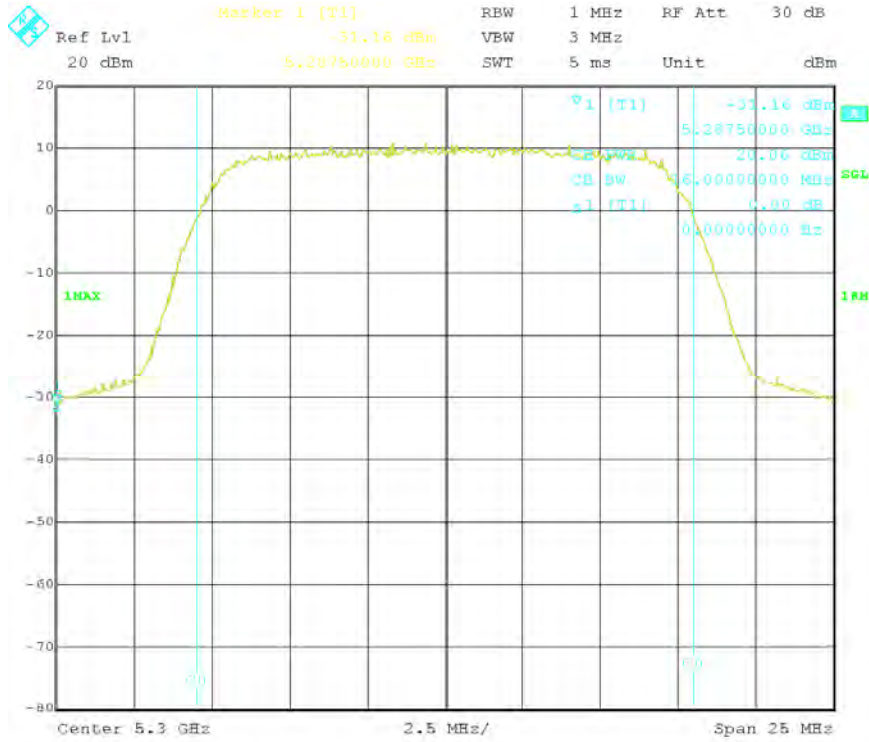

Mid Channel

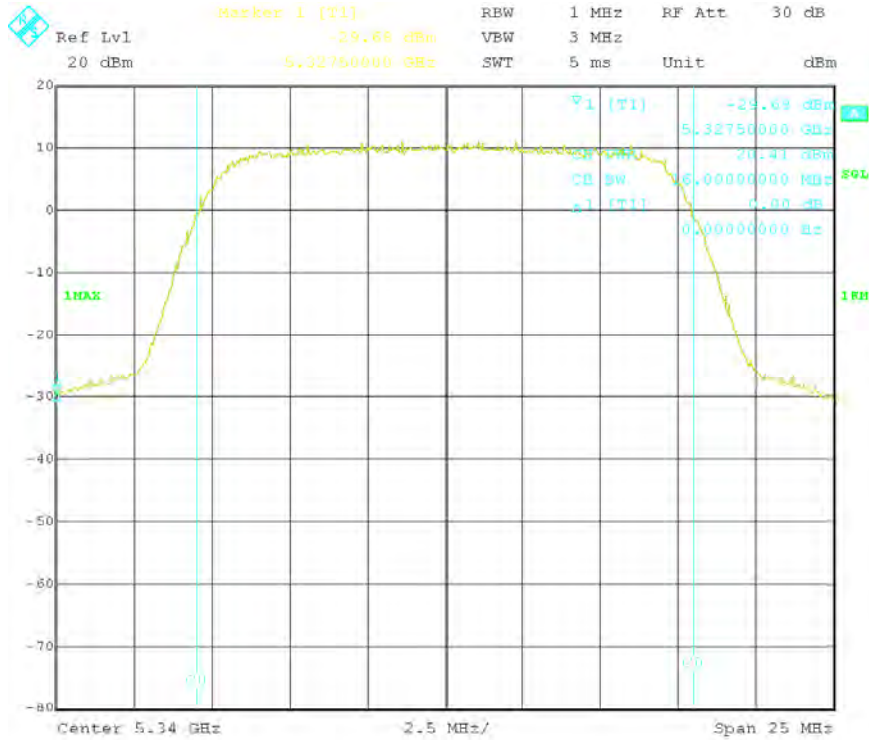

High Channel

Mode: 2 = 16QAM, 16MHz Channel Bandwidth

Mode	Channel Bandwidth	Mode	Power (dBm)
Mode 2	16MHz	Low Channel	20.13
	16MHz	Mid Channel	20.24
	16MHz	High Channel	20.12

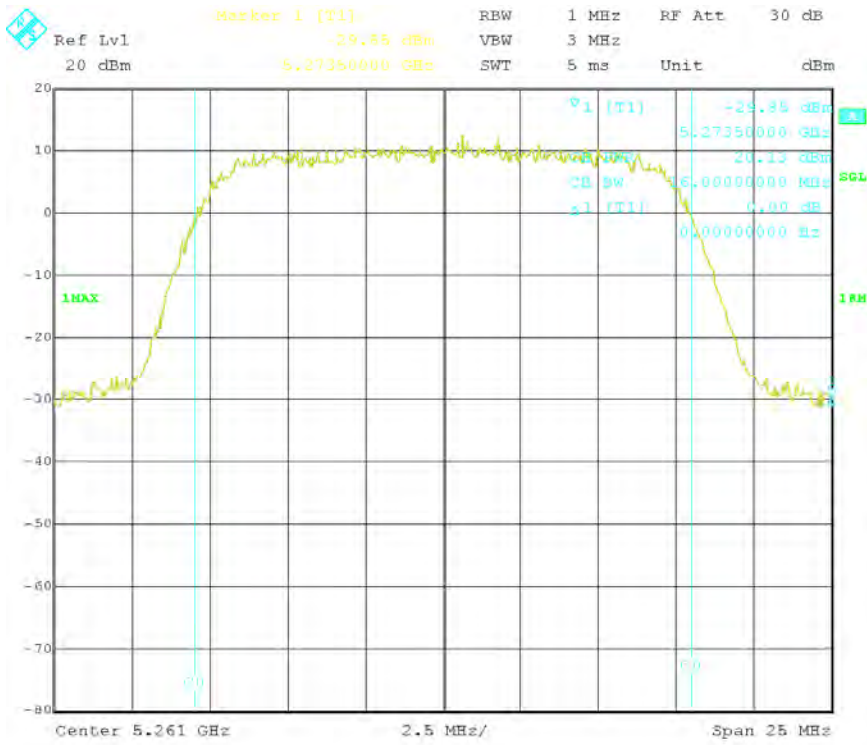

Low Channel

Mode: 3 = 64QAM, 16MHz Channel Bandwidth

Mode	Channel Bandwidth	Mode	Power (dBm)
Mode 3	16MHz	Low Channel	19.32
	16MHz	Mid Channel	19.31
	16MHz	High Channel	19.48

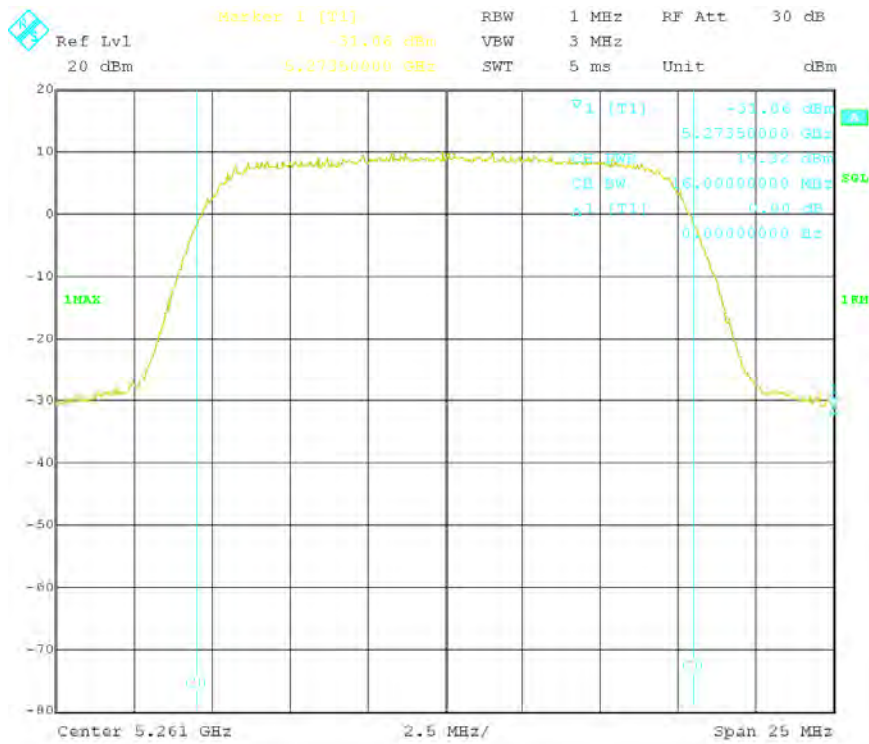

Low Channel

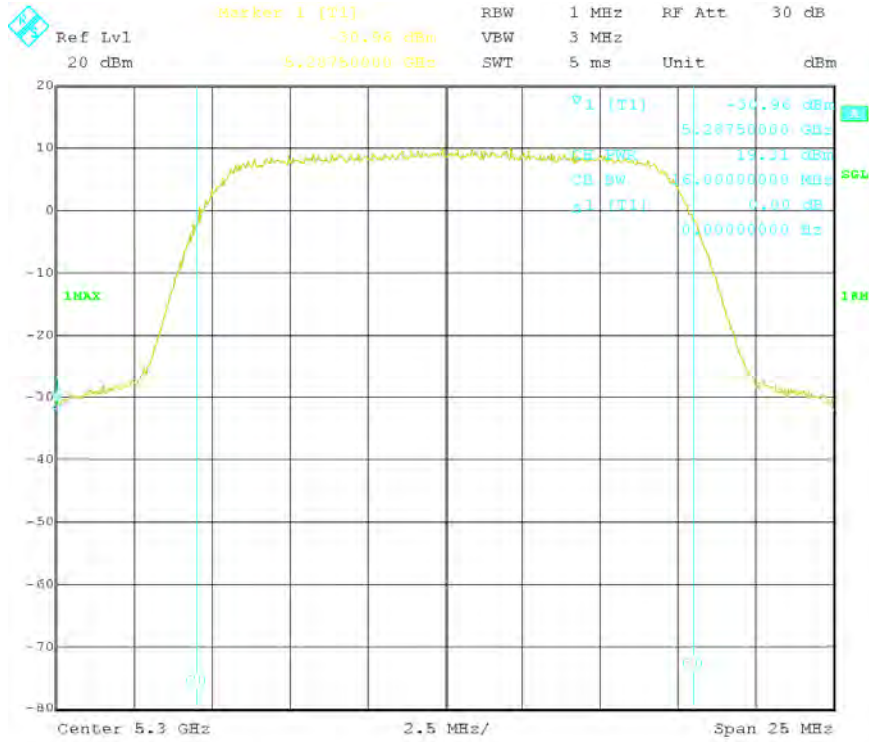

Mid Channel

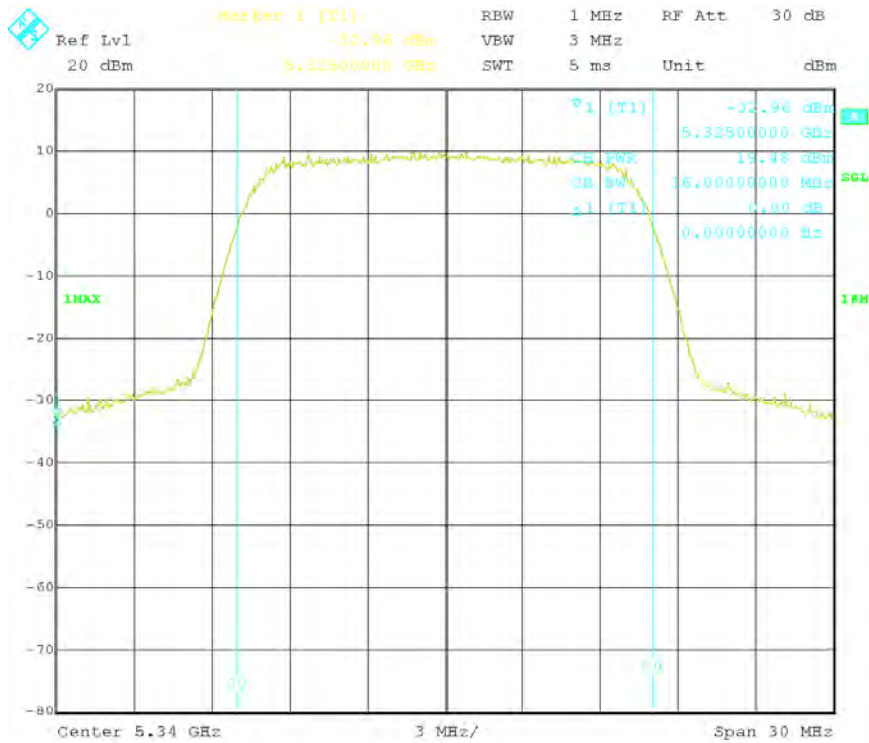

High Channel

Mode: 1 = QPSK, 32MHz Channel Bandwidth

Mode	Channel Bandwidth	Mode	Power (dBm)
Mode 1	32MHz	Low Channel	20.25
	32MHz	Mid Channel	20.22
	32MHz	High Channel	20.21

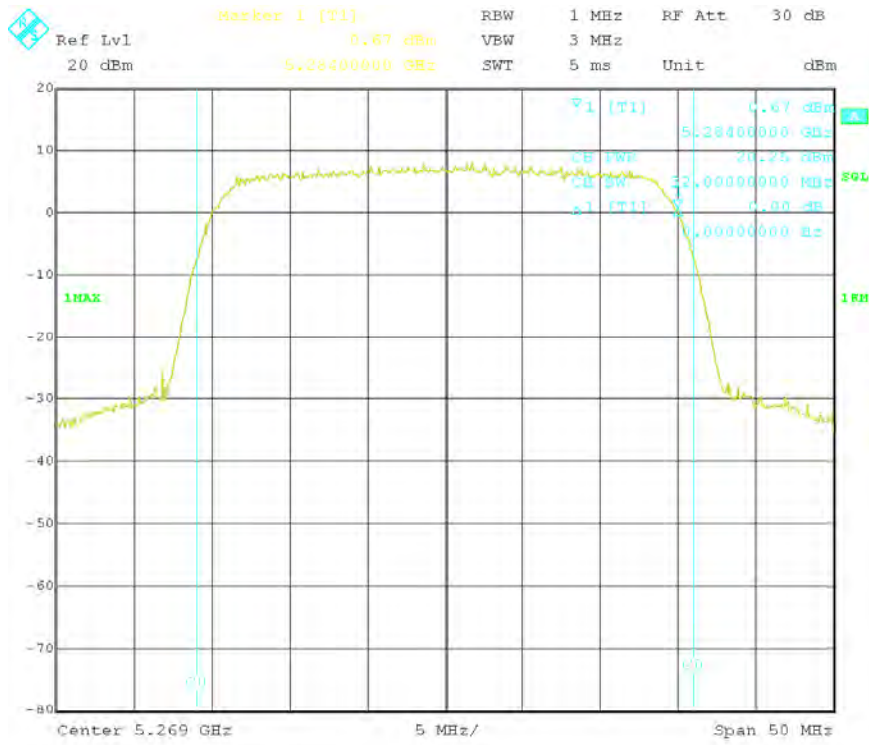

Low Channel

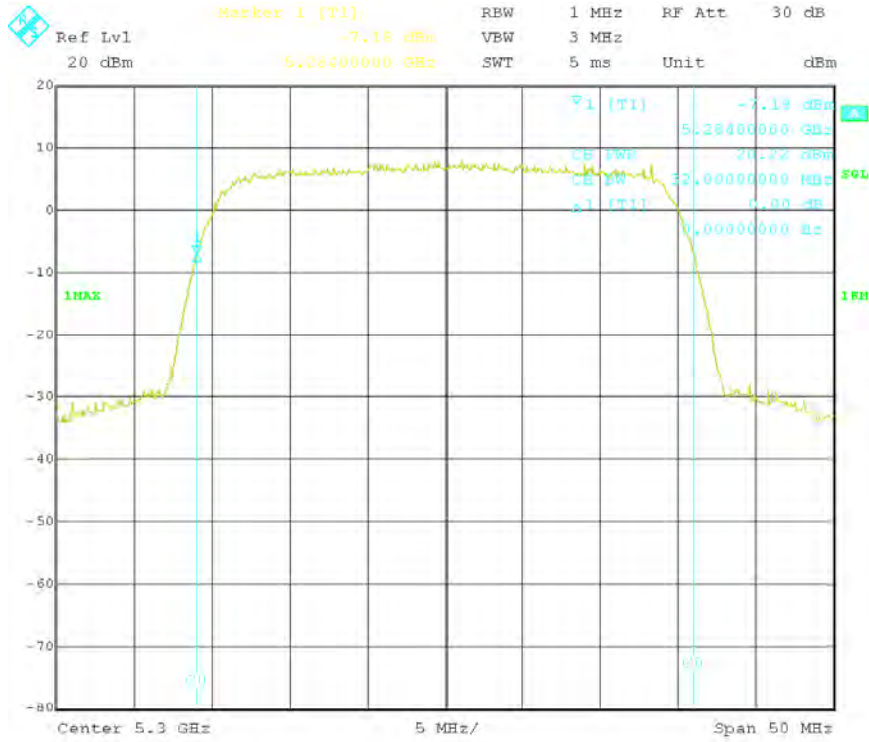

Mid Channel

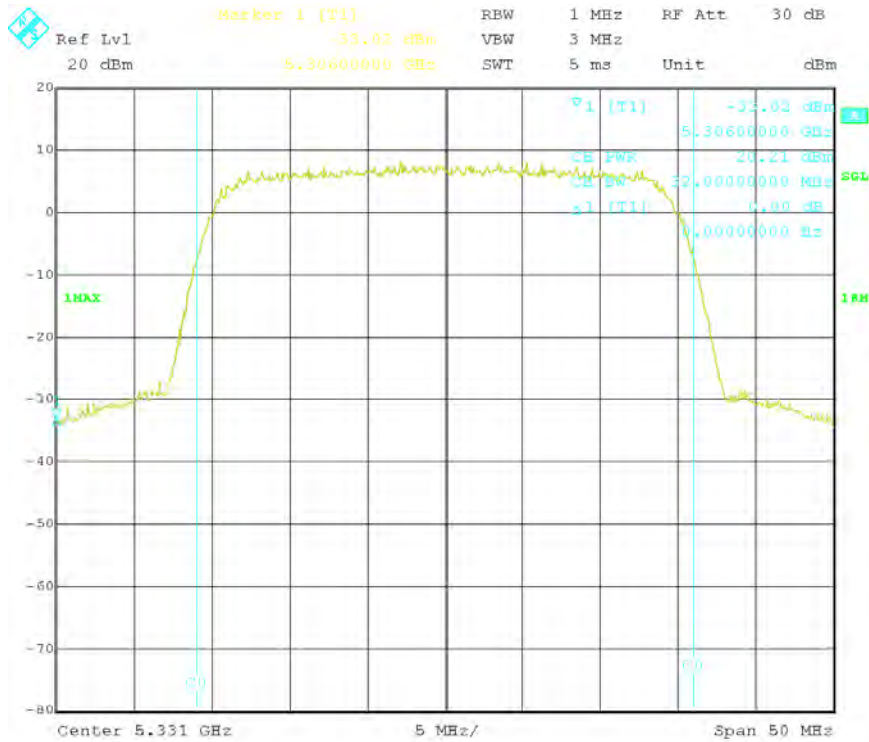

High Channel

Mode: 2 = 16QAM, 32MHz Channel Bandwidth

Mode	Channel Bandwidth	Mode	Power (dBm)
Mode 2	32MHz	Low Channel	20.18
	32MHz	Mid Channel	20.21
	32MHz	High Channel	20.25

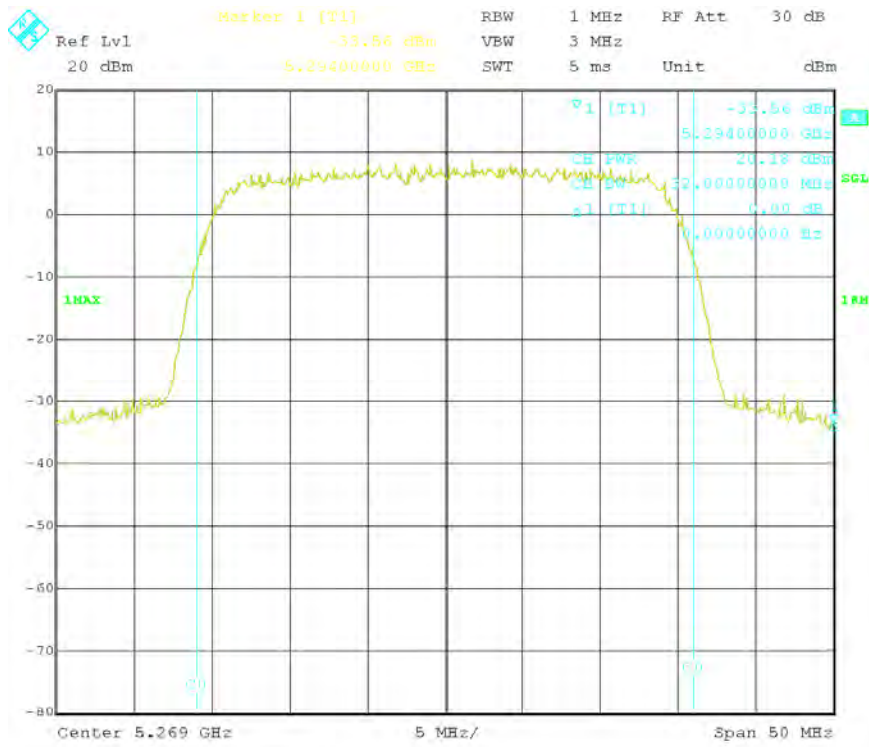

Low Channel

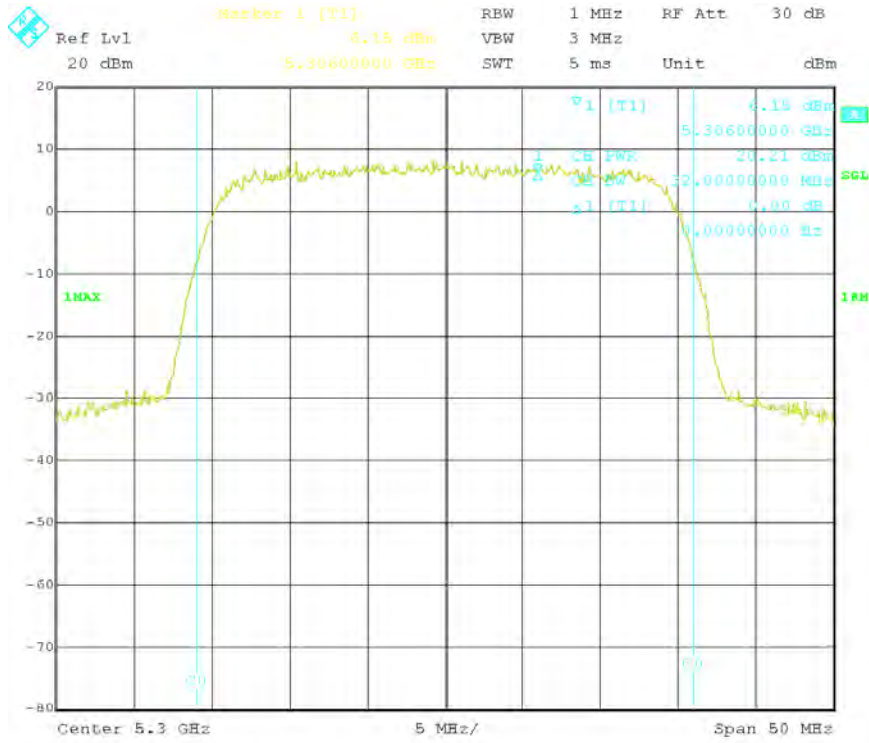

Mid Channel

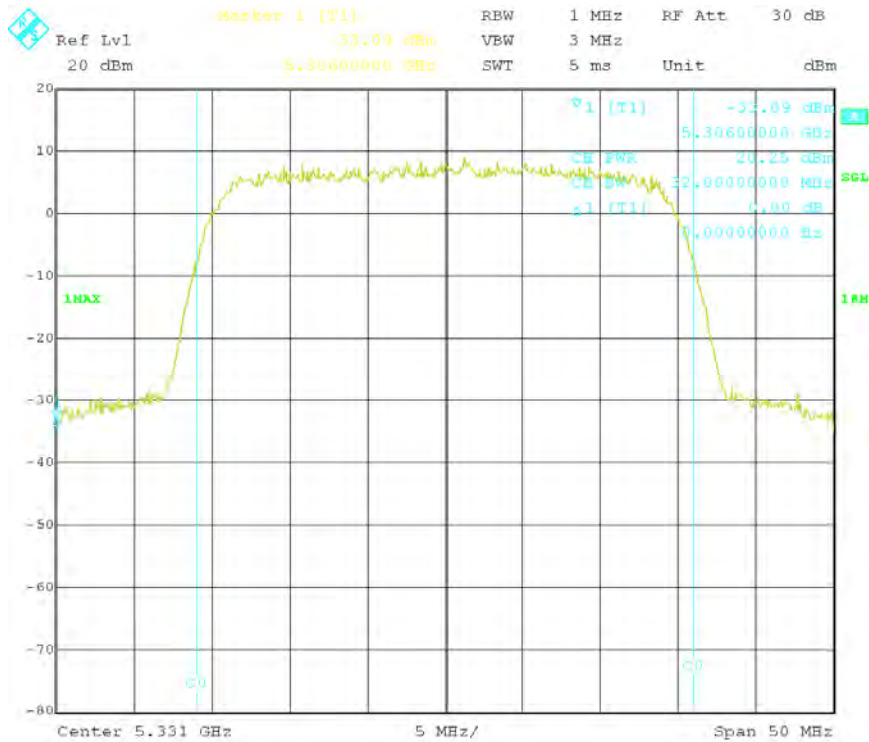

High Channel

Mode: 3 = 64QAM, 32MHz Channel Bandwidth

Mode	Channel Bandwidth	Mode	Power (dBm)
Mode 3	32MHz	Low Channel	19.39
	32MHz	Mid Channel	19.34
	32MHz	High Channel	19.48

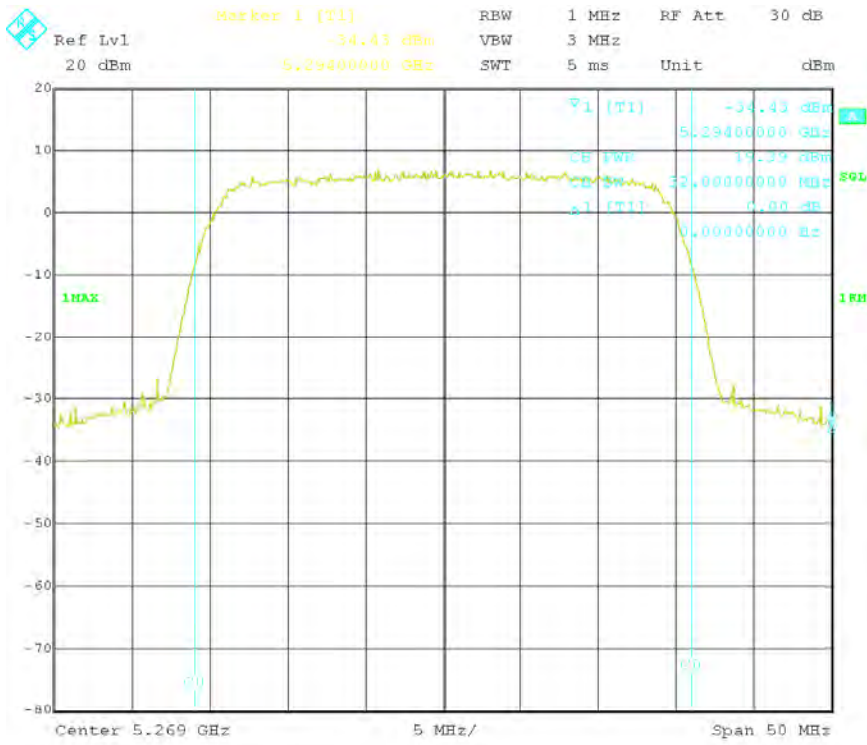

Low Channel

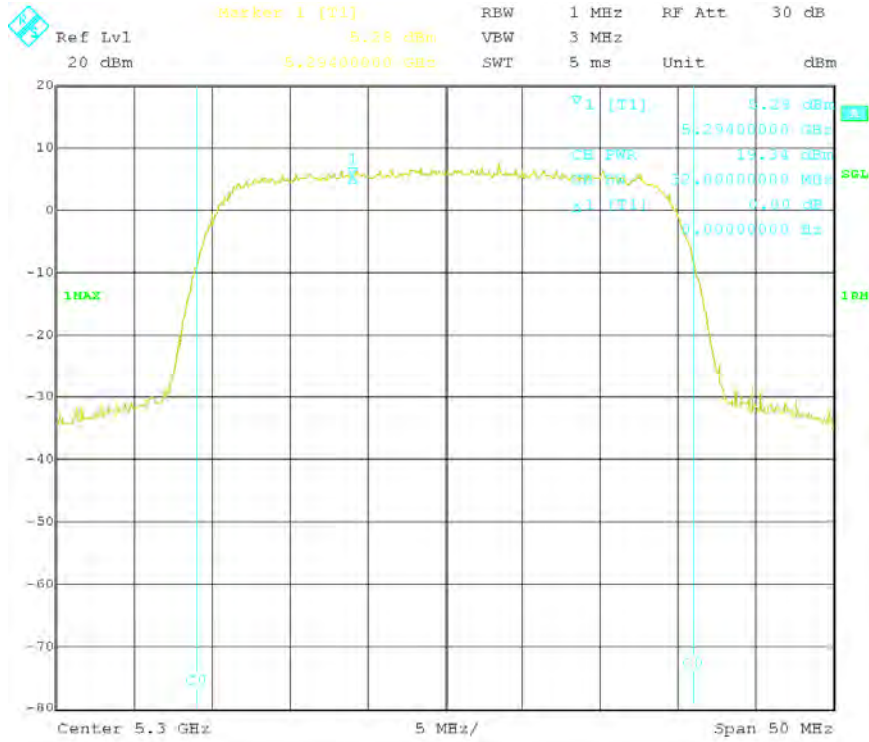

Mid Channel

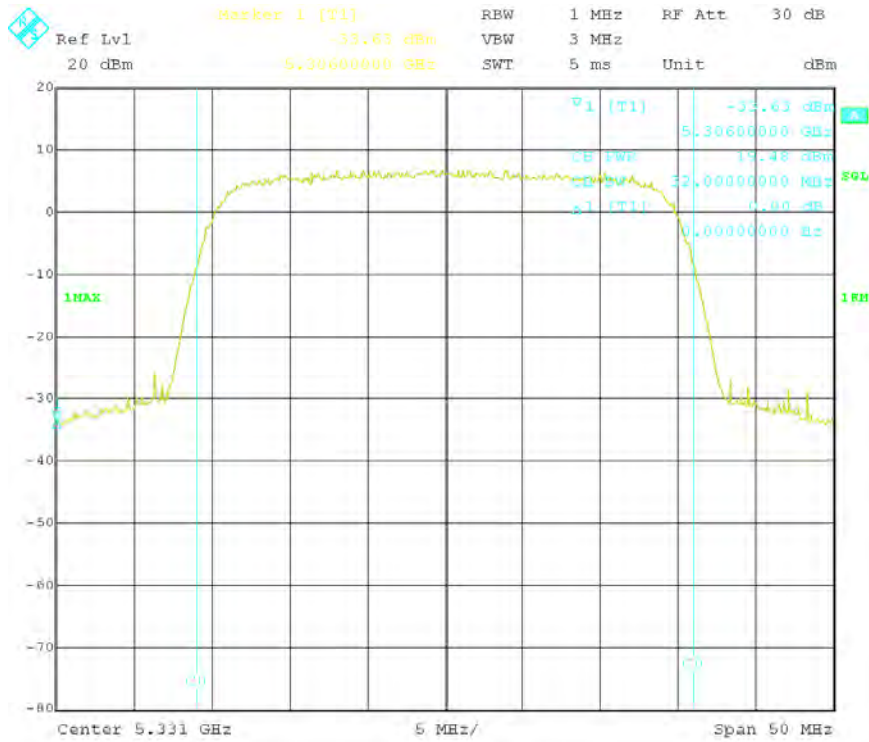

High Channel

5.4GHz Band

Mode: 1 = QPSK, 8MHz Channel Bandwidth

Mode	Channel Bandwidth	Mode	Power (dBm)
Mode 3	8MHz	Low Channel	20.10
	8MHz	Mid Channel	20.12
	8MHz	High Channel	20.06

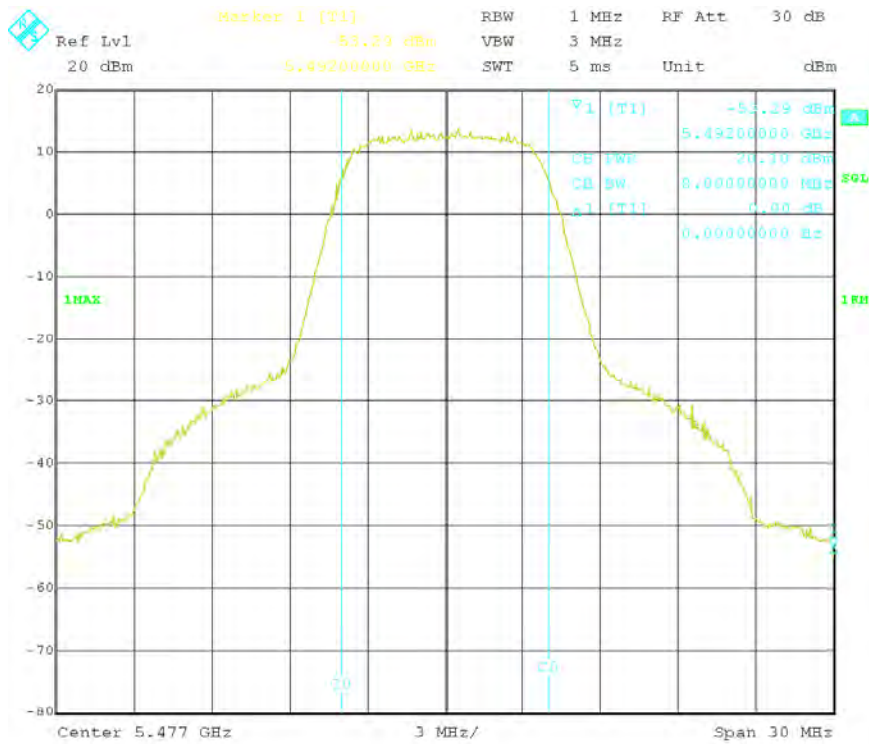

Low Channel

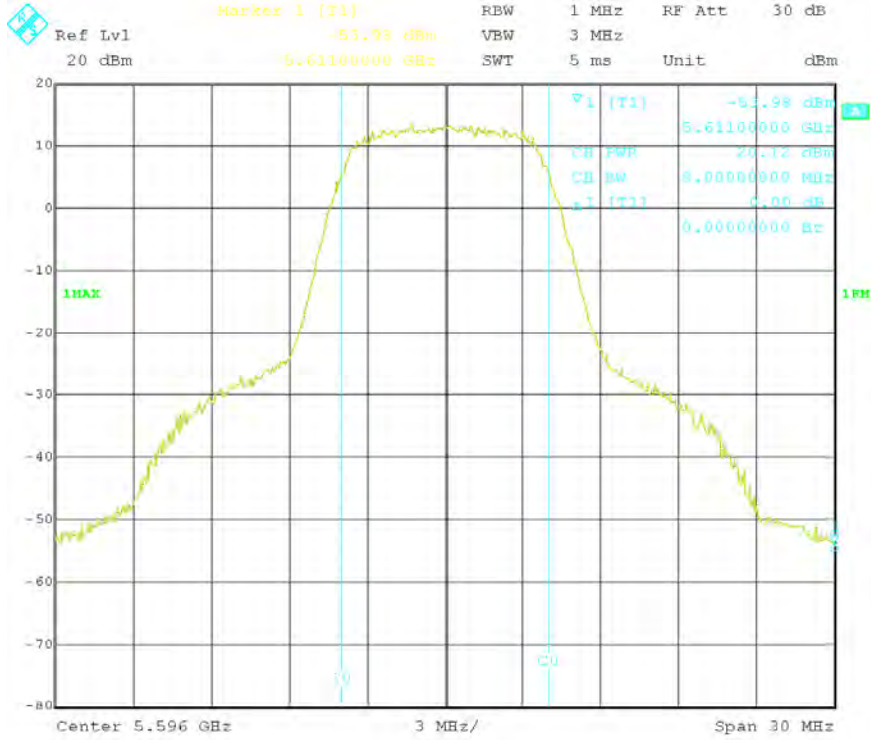

Mid Channel

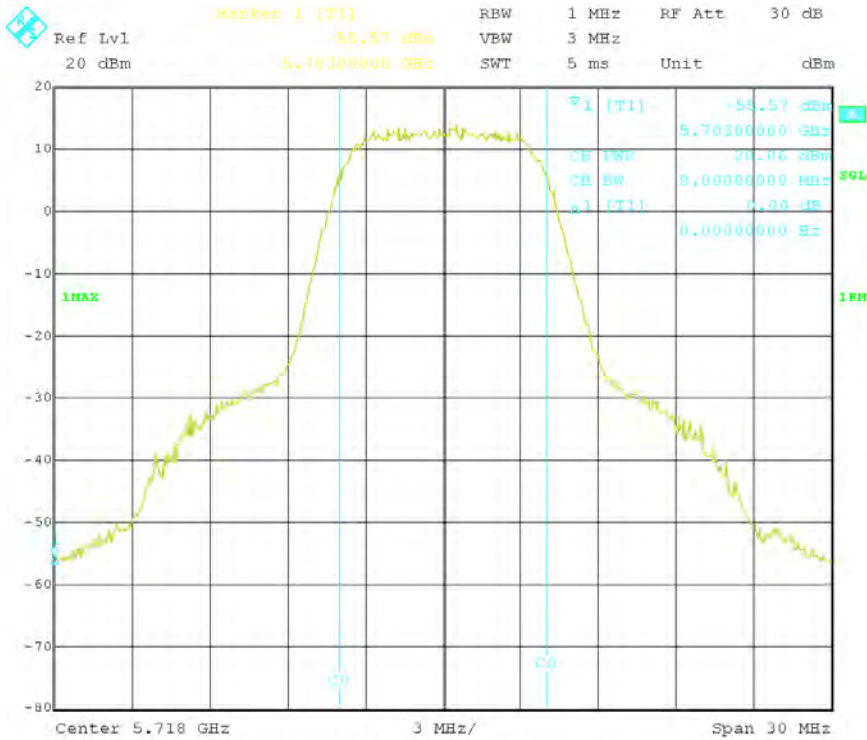

High Channel

Mode: 2 = 16QAM, 8MHz Channel Bandwidth

Mode	Channel Bandwidth	Mode	Power (dBm)
Mode 2	8MHz	Low Channel	20.56
	8MHz	Mid Channel	20.42
	8MHz	High Channel	20.06

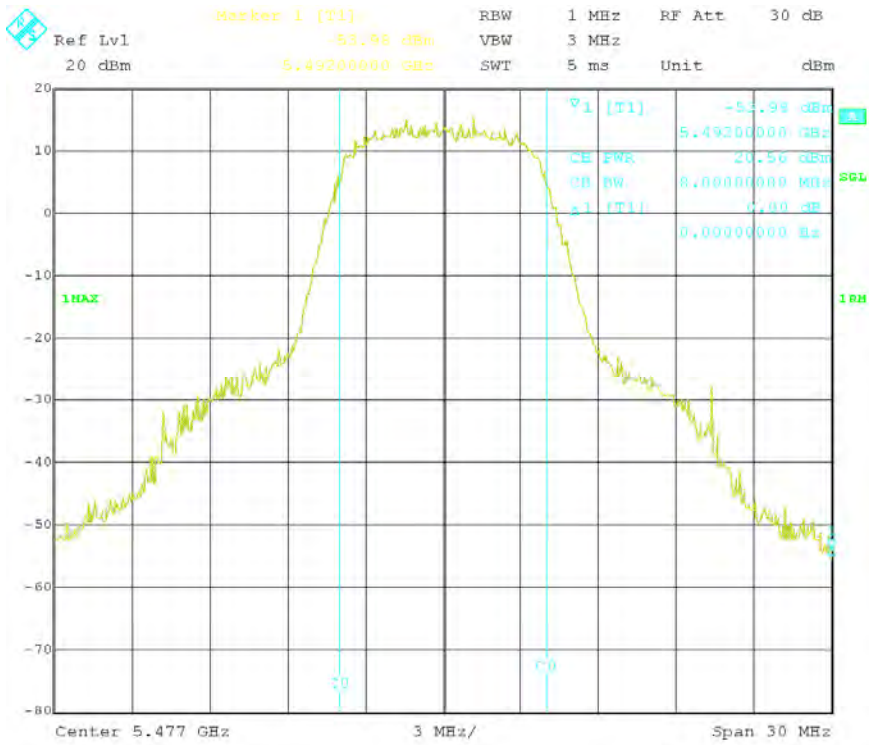

Low Channel

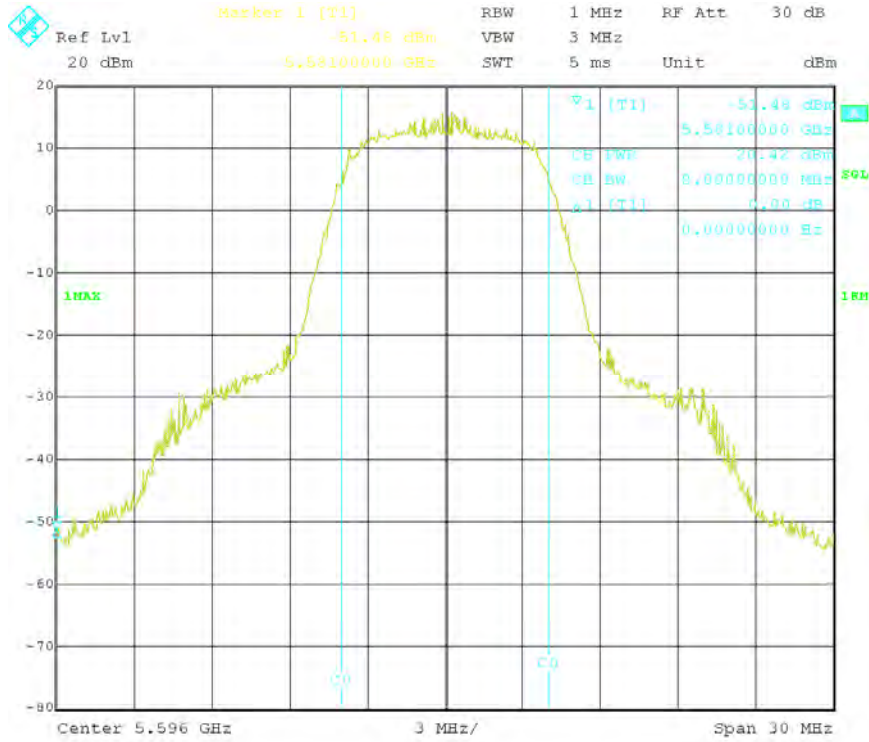

Mid Channel

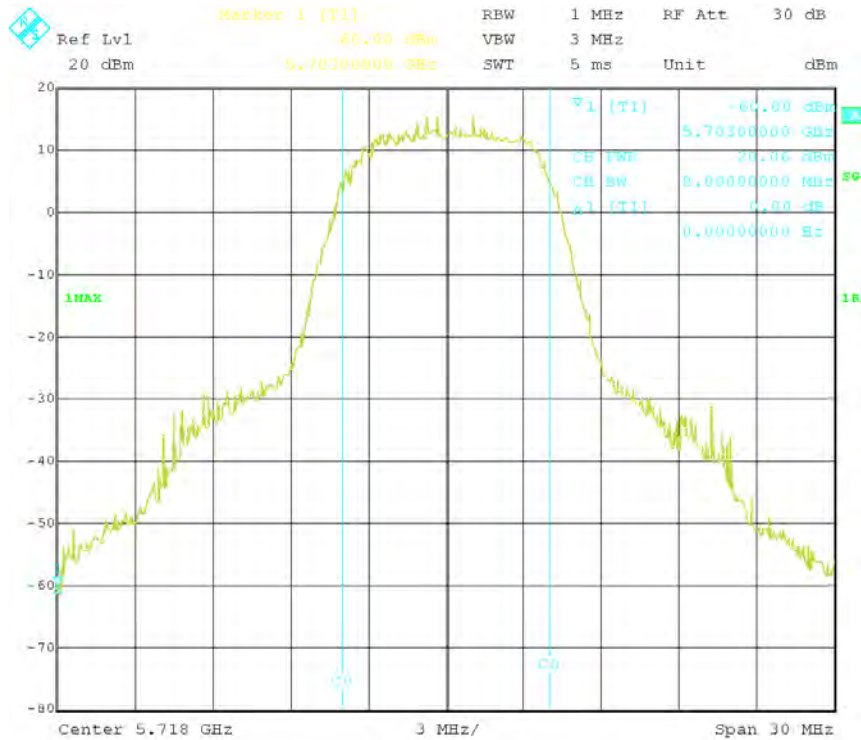

High Channel

Mode: 3 = 64QAM, 8MHz Channel Bandwidth

Mode	Channel Bandwidth	Mode	Power (dBm)
Mode 3	8MHz	Low Channel	19.78
	8MHz	Mid Channel	19.70
	8MHz	High Channel	19.33

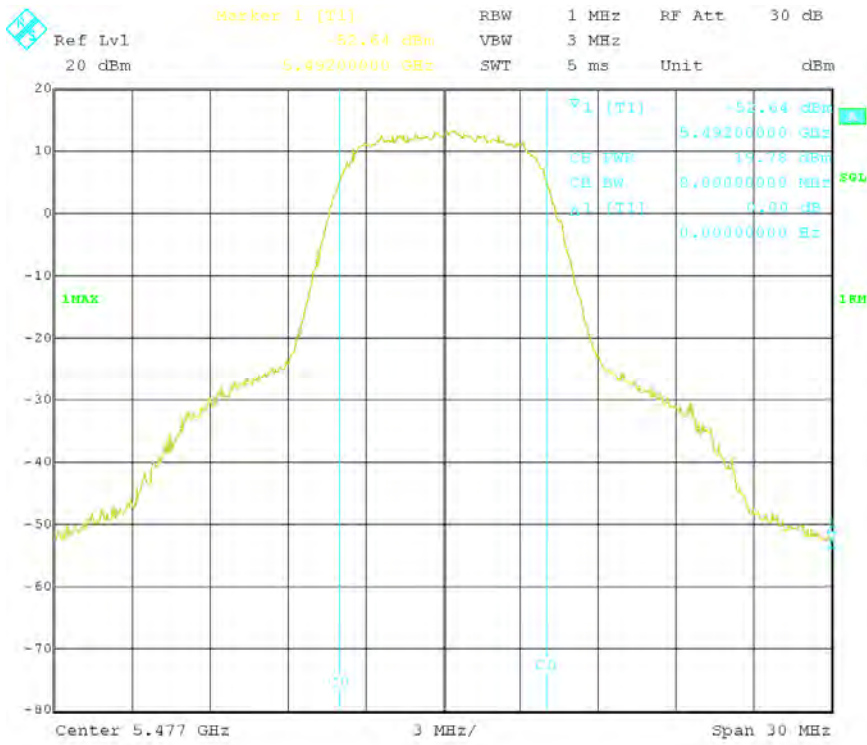

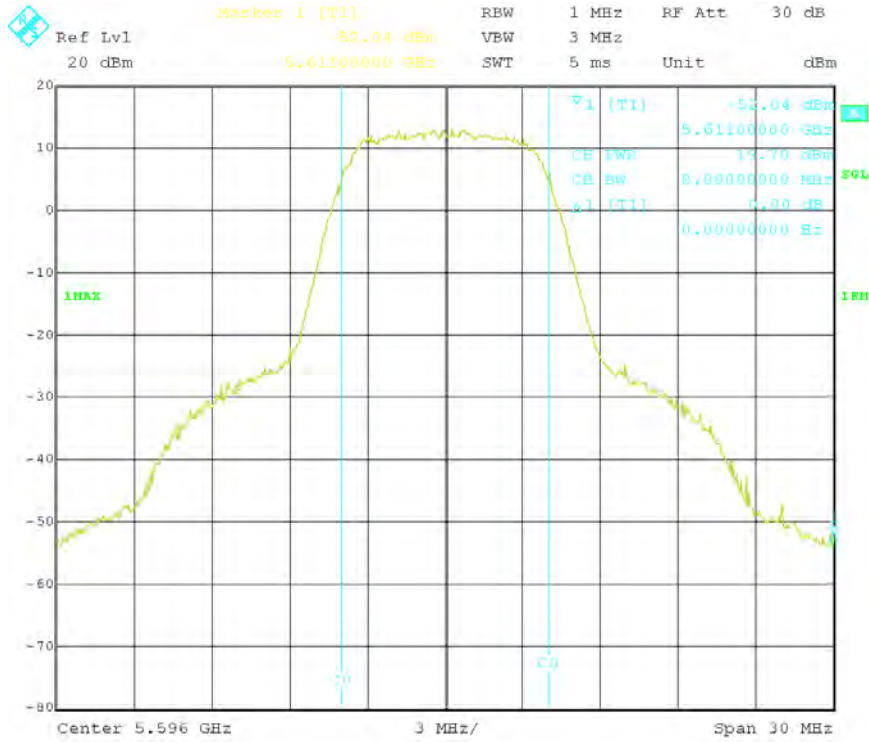

Mid Channel

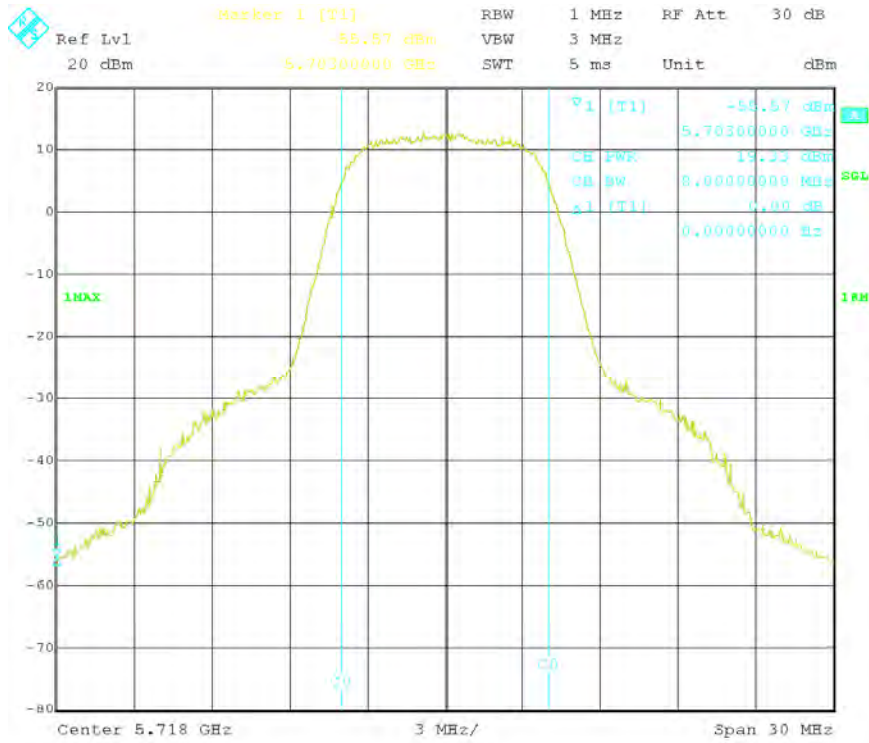

High Channel

Mode: 1 = QPSK, 16MHz Channel Bandwidth

Mode	Channel Bandwidth	Mode	Power (dBm)
Mode 1	16MHz	Low Channel	20.03
	16MHz	Mid Channel	20.09
	16MHz	High Channel	20.09

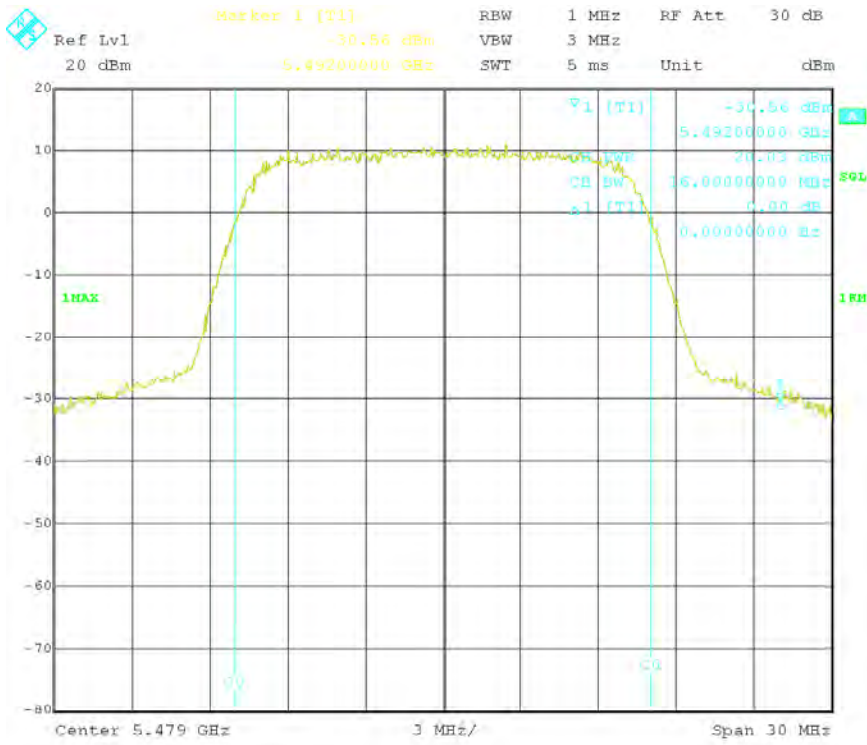

Low Channel

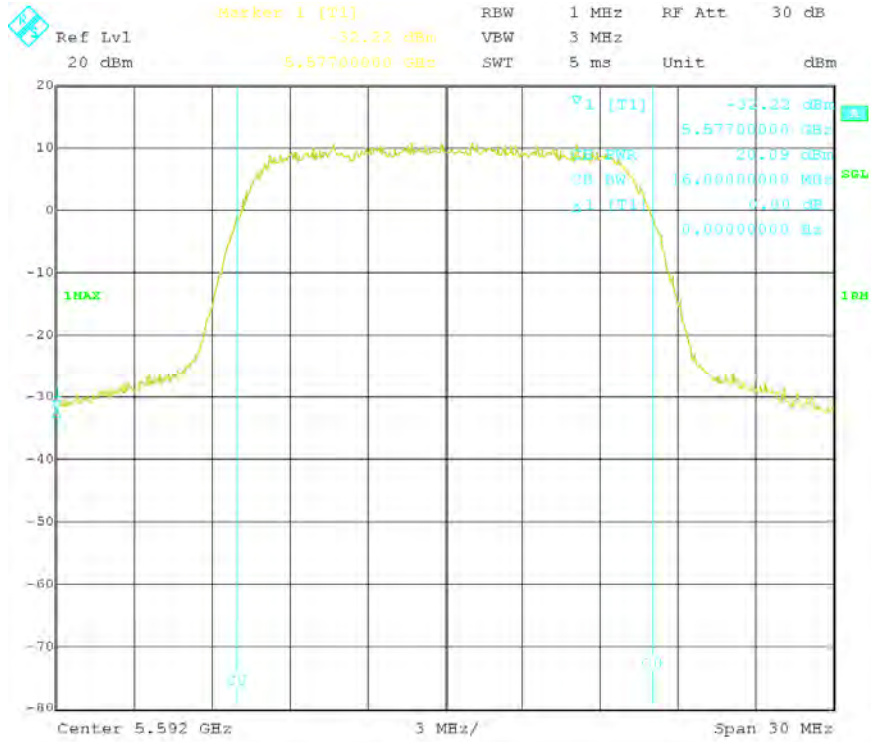

Mid Channel

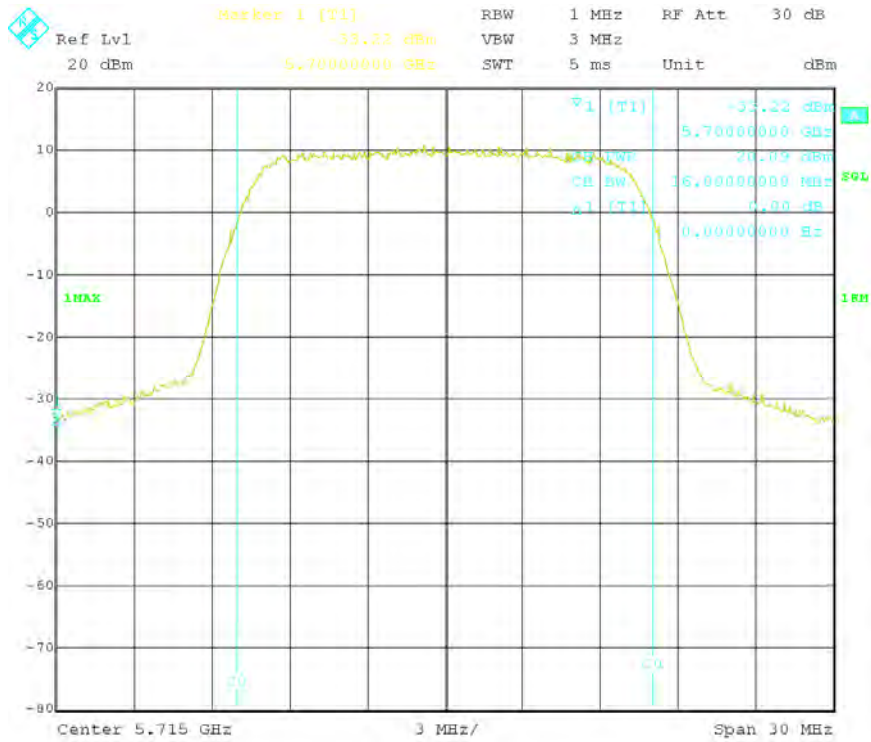

High Channel

Mode: 2 = 16QAM, 16MHz Channel Bandwidth

Mode	Channel Bandwidth	Mode	Power (dBm)
Mode 2	16MHz	Low Channel	20.29
	16MHz	Mid Channel	20.08
	16MHz	High Channel	20.20

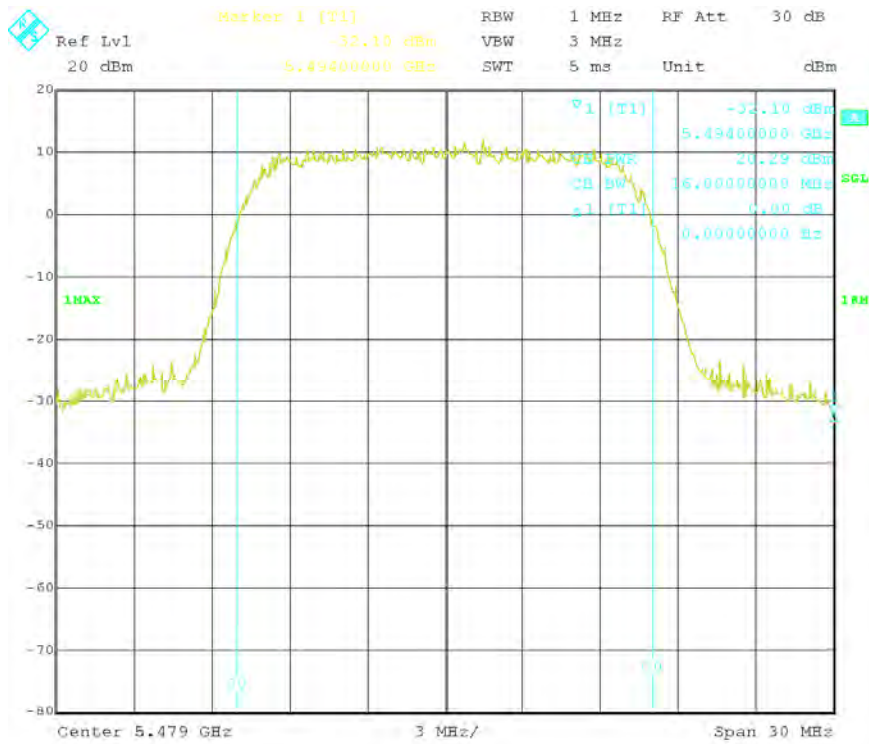

Low Channel

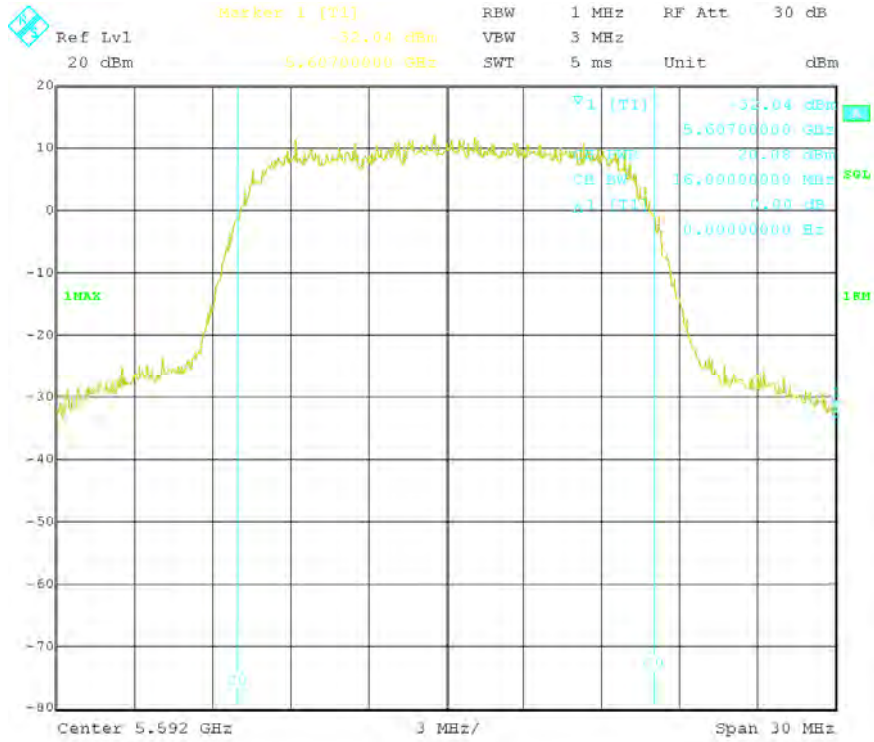

Mid Channel

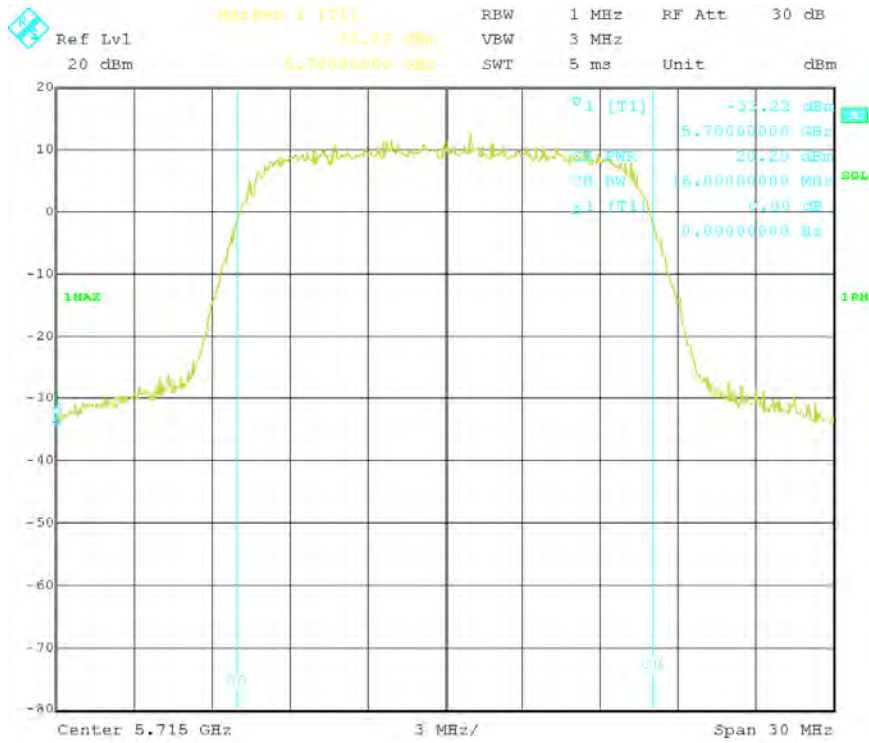

High Channel

Mode: 3 = 64QAM, 16MHz Channel Bandwidth

Mode	Channel Bandwidth	Mode	Power (dBm)
Mode 3	16MHz	Low Channel	19.85
	16MHz	Mid Channel	19.98
	16MHz	High Channel	19.16

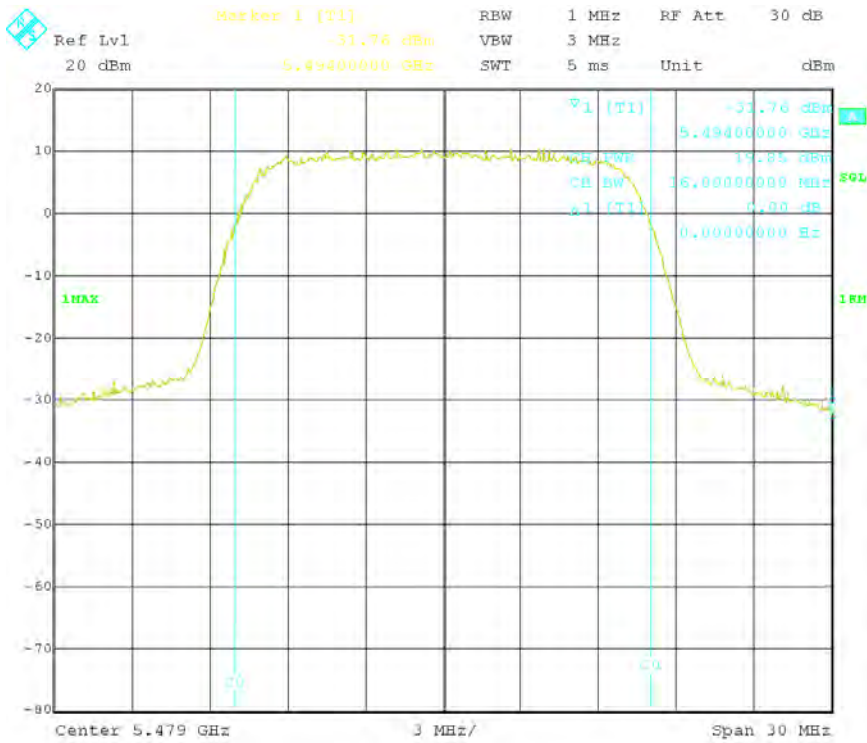

Low Channel

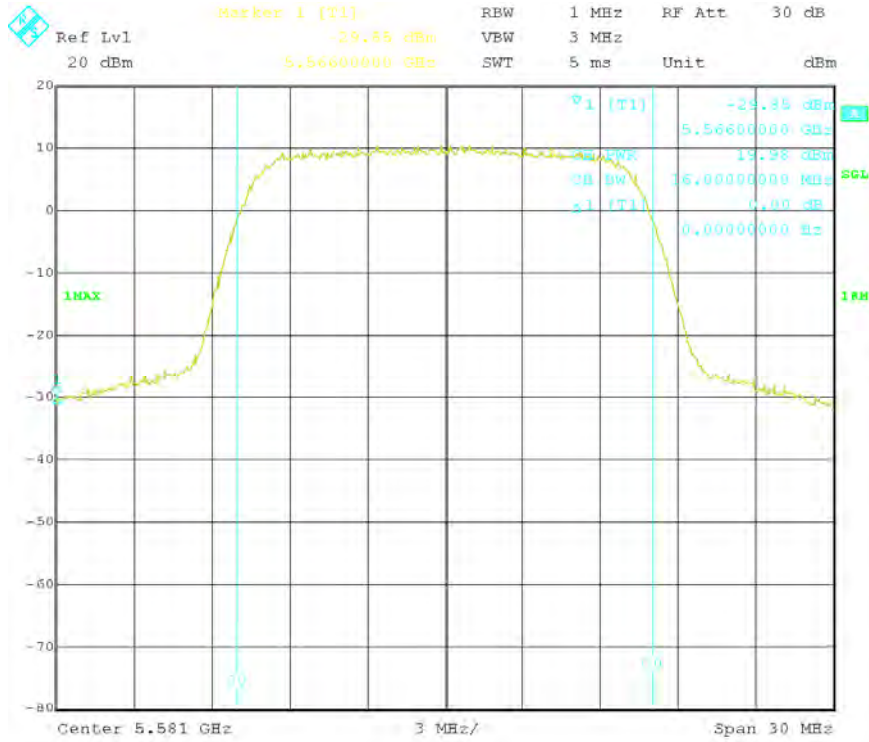

Mid Channel

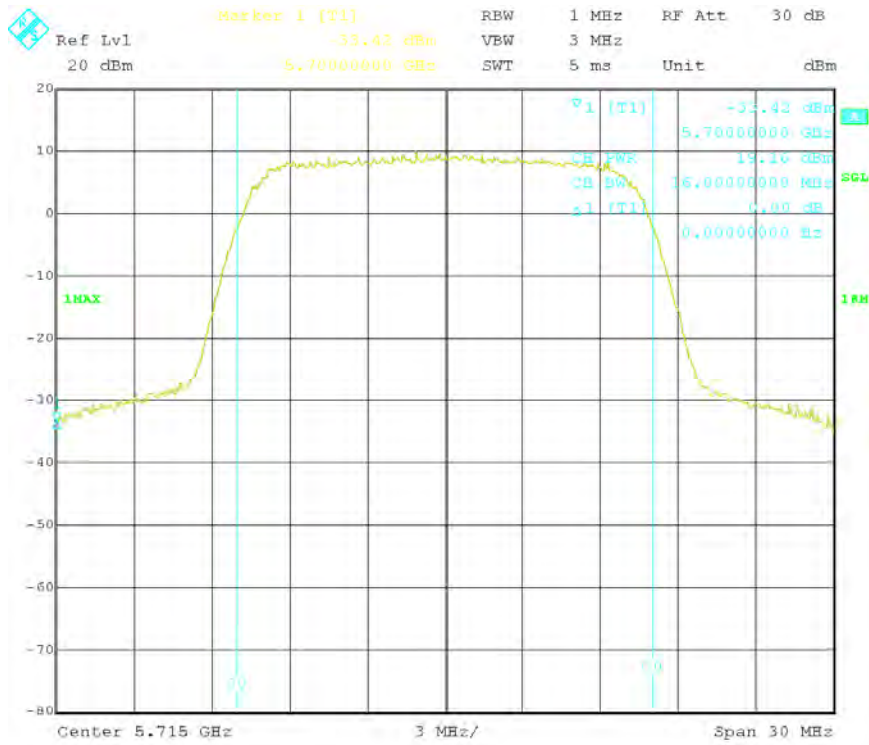

High Channel

Mode: 1 = QPSK, 32MHz Channel Bandwidth

Mode	Channel Bandwidth	Mode	Power (dBm)
Mode 1	32MHz	Low Channel	20.24
	32MHz	Mid Channel	20.22
	32MHz	High Channel	20.03

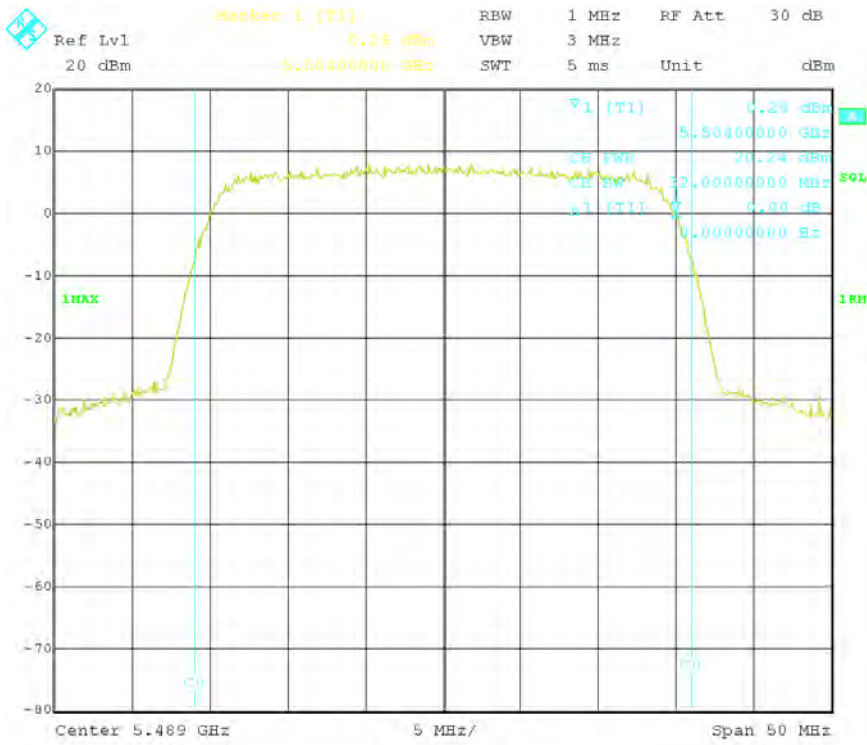

Low Channel

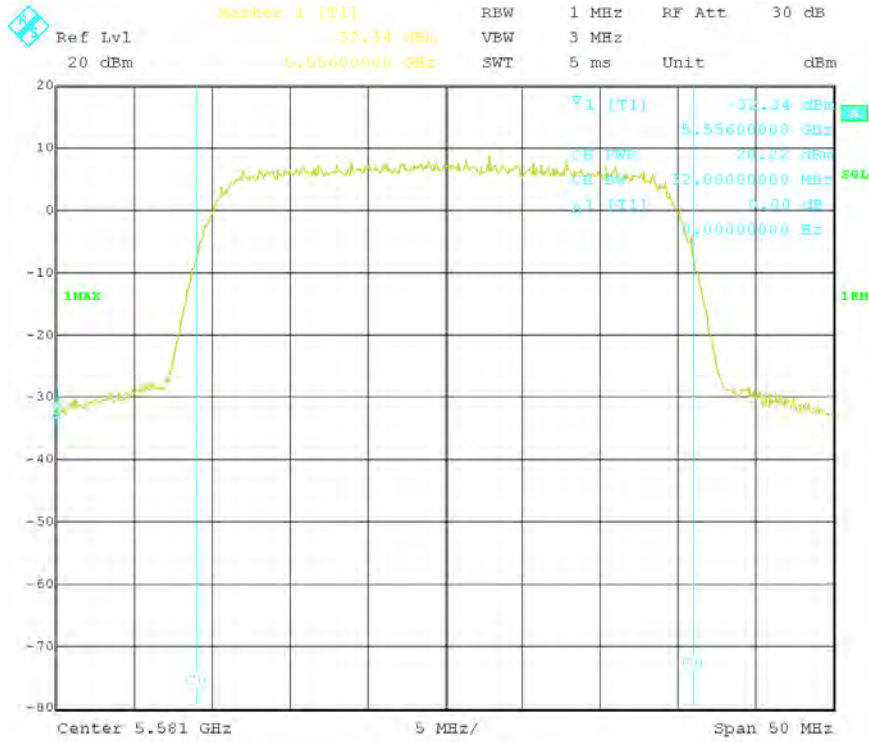

Mid Channel

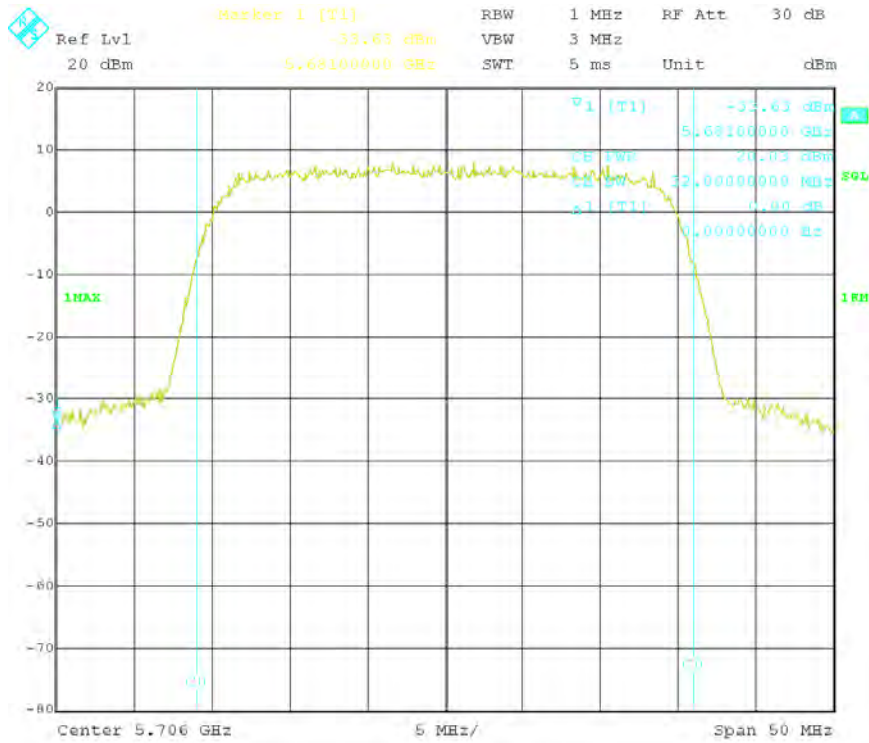

High Channel

Mode: 2 = 16QAM, 32MHz Channel Bandwidth

Mode	Channel Bandwidth	Mode	Power (dBm)
Mode 2	32MHz	Low Channel	20.10
	32MHz	Mid Channel	20.30
	32MHz	High Channel	20.29

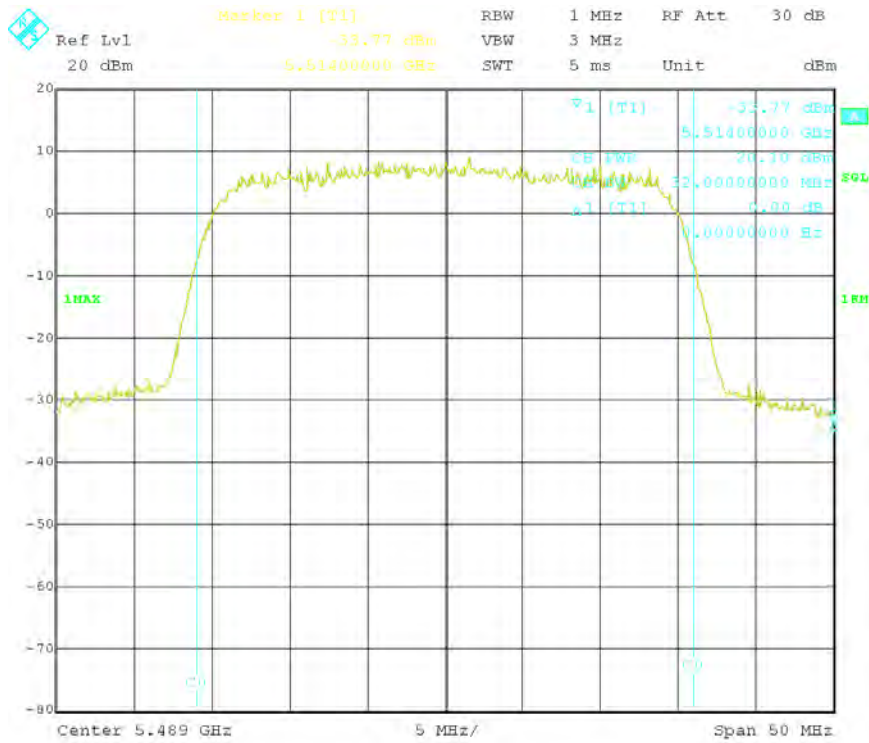

Low Channel

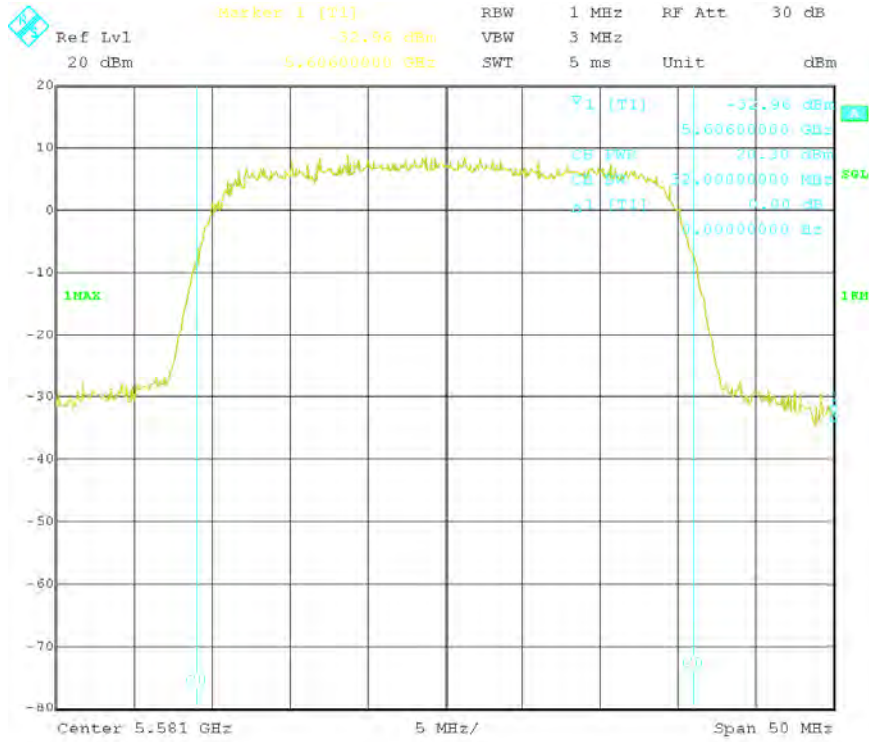

Mid Channel

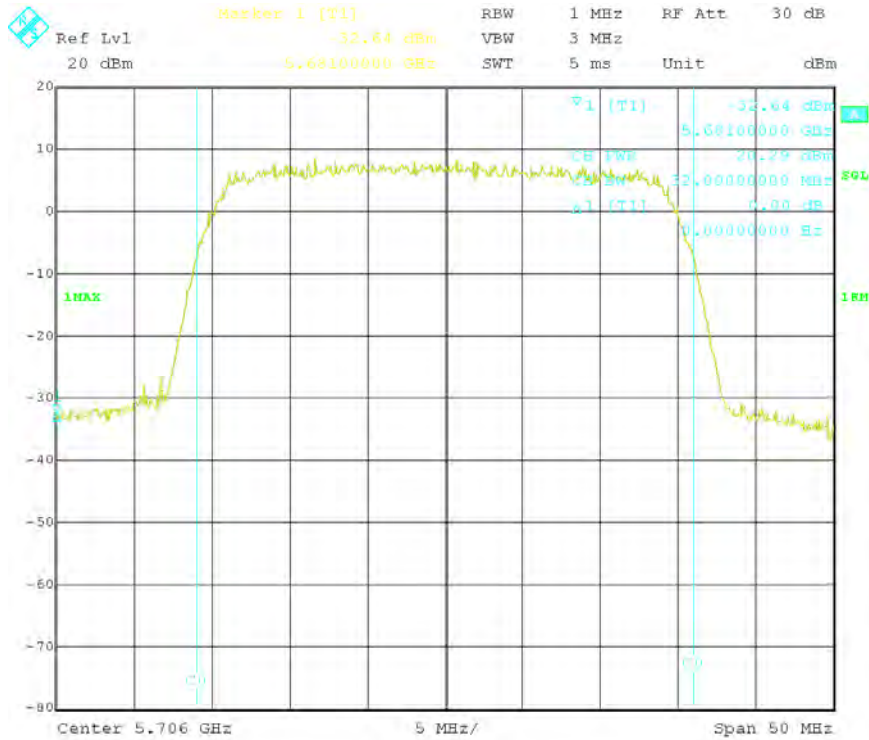

High Channel

Mode: 3= 64QAM, 32MHz Channel Bandwidth

Mode	Channel Bandwidth	Mode	Power (dBm)
Mode 3	32MHz	Low Channel	19.59
	32MHz	Mid Channel	19.42
	32MHz	High Channel	19.08

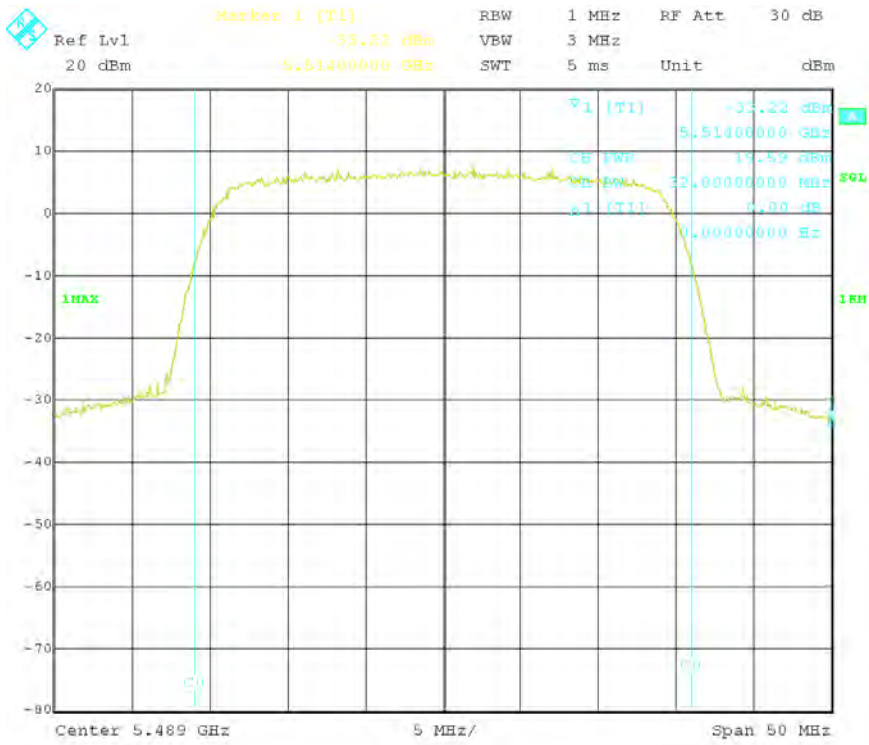

Low Channel

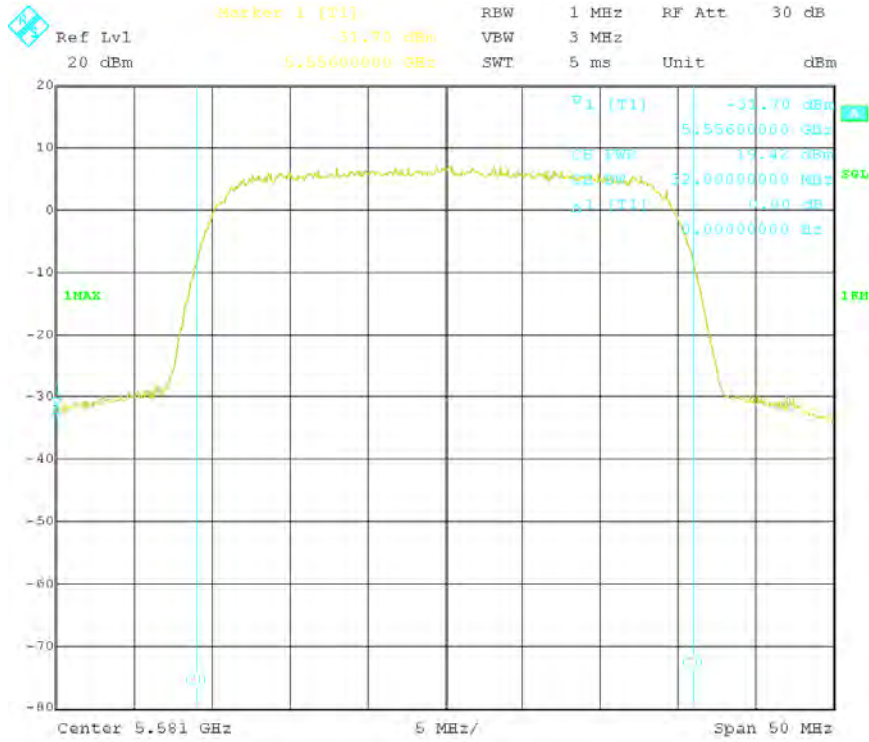

Mid Channel

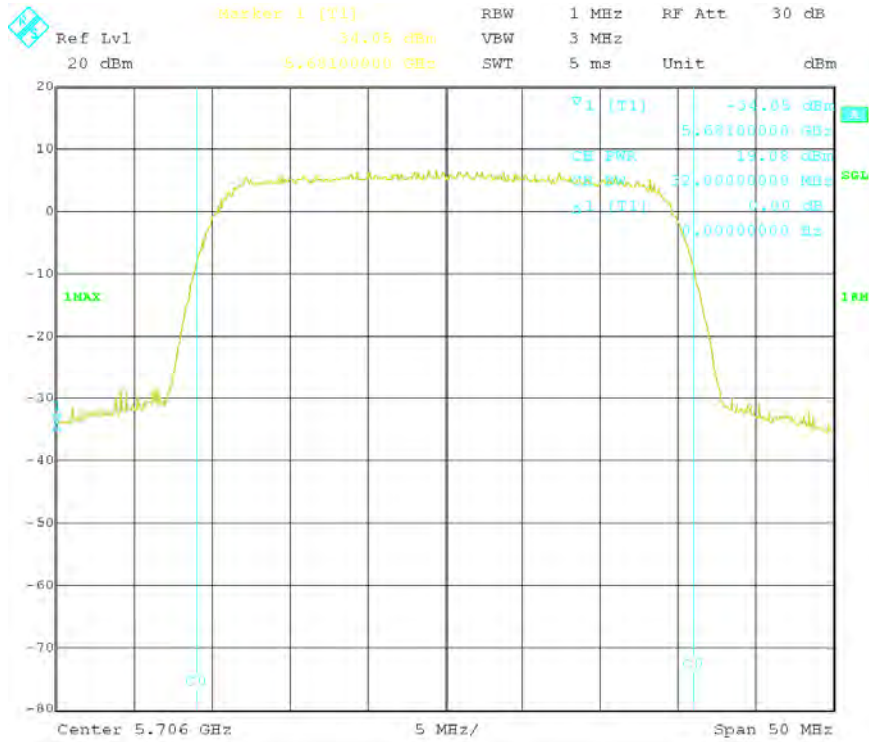

High Channel

5.6 Radiated Spurious Emissions <1GHz

1. All possible modes of operation were investigated. Only the 6 worst case emissions measured, using the correct CISPR detectors, are reported. All other emissions were relatively insignificant.
2. A "-ve" margin indicates a PASS as it refers to the margin present below the limit line at the particular frequency.
3. Radiated Emissions Measurement Uncertainty
All test measurements carried out are traceable to national standards. The uncertainty of the measurement at a confidence level of approximately 95% (in the case where distributions are normal), with a coverage factor of 2, in the range 30MHz – 1GHz (QP only @ 3m & 10m) is +5.6dB/-4.5dB (for EUTs < 0.5m X 0.5m X 0.5m).
4. Environmental Conditions

Temperature	23°C
Relative Humidity	50%
Atmospheric Pressure	1019mbar

Test Date : August 01-15, 2012
Tested By : Choon Sian Ooi

Standard Requirement: 47 CFR §15.407(b)(2), §15.205(a)/ §15.209(a) ; RSS210(A8.5)

Procedures: Radiated emissions were measured according to ANSI C63.4. The EUT was set to transmit at the highest output power. The EUT was set to transmit at mid channel. Note that setting the channel other than mid, the spurious emissions are the same.

The limit is converted from microvolts/meter to decibel microvolts/meter.

Sample Calculation: Corrected Amplitude = Raw Amplitude(dBμV/m) + ACF(dB) + Cable Loss(dB)

Power Level: As specified by the following matrix, see section 5.5 Peak Output Power

Antenna	Antenna Gain	Bandwidth (MHz)	Antenna Gain >6dBi (Antenna Gain- dBi)	Max Allowable Conducted Power (dBm)
Panel	29	8	23	-2.62
		16		-2.41
		32		-3.00
Parabolic Dish	37.9	8	31.9	-11.52
		16		-8.49
		32		-7.90

Radiated Emission Plot (Transmit Mode)

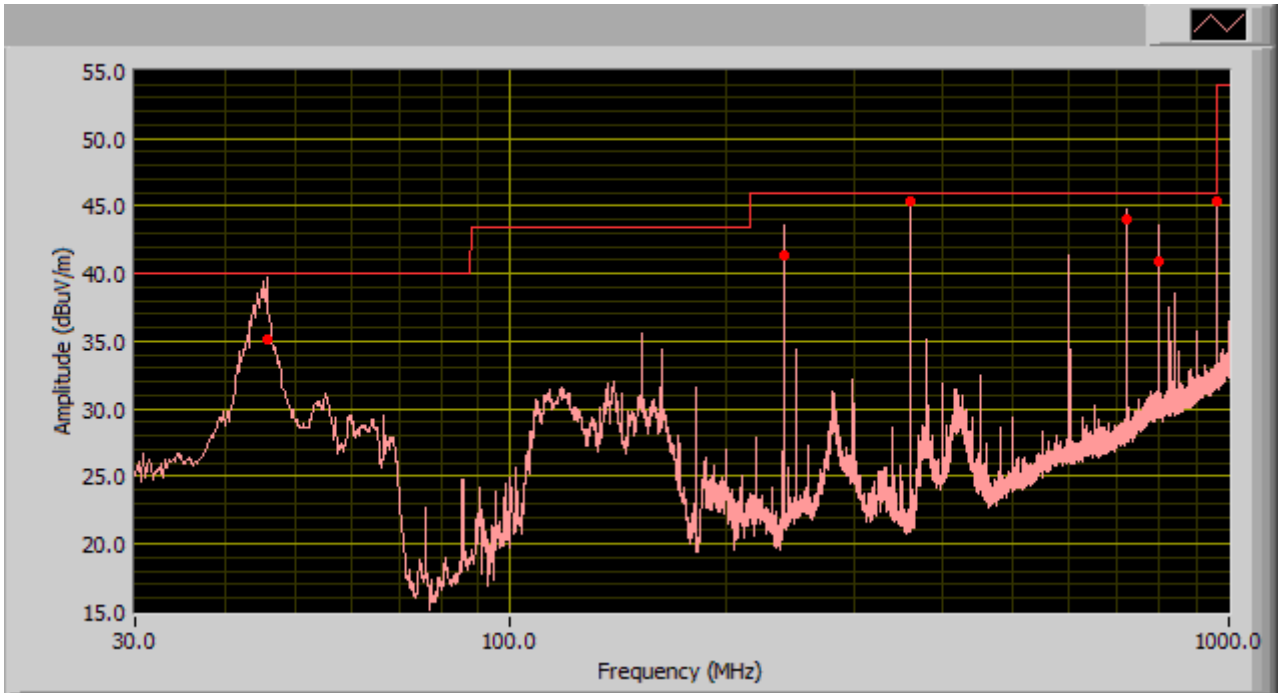

Frequency (MHz)	Quasi-Peak (dBµV/m)	Antenna height (cm)	Polarity	Turntable position (deg)	Limit (dBµV/m)	Margin (dB)
45.73	35.09	344.00	V	135.00	40.00	-4.91
359.99	45.30	192.00	H	200.00	46.00	-0.70
959.99	45.31	207.00	H	108.00	46.00	-0.69
719.99	44.10	189.00	H	106.00	46.00	-1.90
239.99	41.32	237.00	H	123.00	46.00	-4.68
800.00	40.91	196.00	H	103.00	46.00	-5.09

Test Data

Radiated Emission Plot (Receive Mode)

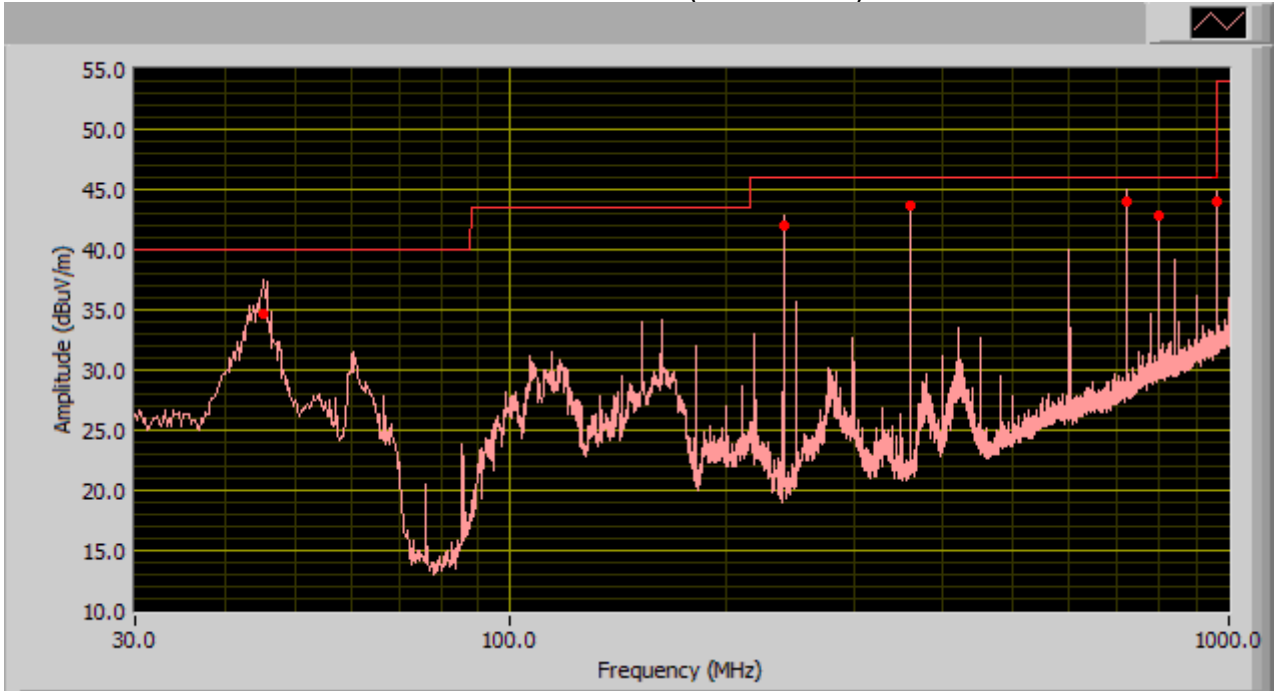

Test Data

Frequency (MHz)	Quasi-Peak (dBµV/m)	Antenna height (cm)	Polarity	Turntable position (deg)	Limit (dBµV/m)	Margin (dB)
359.99	43.65	190.00	H	188.00	46.00	-2.35
719.99	43.95	190.00	H	100.00	46.00	-2.05
959.98	44.04	207.00	H	111.00	46.00	-1.96
45.26	34.62	331.00	V	125.00	40.00	-5.38
799.94	42.75	186.00	H	100.00	46.00	-3.25
239.99	41.97	235.00	H	125.00	46.00	-4.03

5.7 Radiated Spurious Emissions >1GHz and Band edge

1. All possible modes of operation were investigated. Only the 6 worst case emissions measured, using the correct CISPR detectors, are reported. All other emissions were relatively insignificant.
2. A "-ve" margin indicates a PASS as it refers to the margin present below the limit line at the particular frequency.
3. Radiated Emissions Measurement Uncertainty
All test measurements carried out are traceable to national standards. The uncertainty of the measurement at a confidence level of approximately 95% (in the case where distributions are normal), with a coverage factor of 2, in the range 1GHz – 40GH is +5.6dB/-4.5dB (for EUTs < 0.5m X 0.5m X 0.5m).
4. Environmental Conditions

Temperature	23°C
Relative Humidity	50%
Atmospheric Pressure	1019mbar

Test Date : August 01-15, 2012
Tested By : Choon Sian Ooi

Standard Requirement: 47 CFR §15.407(b)(2), §15.205(a)/ §15.209(a) ; RSS210(A8.5)

Procedures: Equipment was setup in a semi-anechoic chamber. For measurements above 1 GHz an average measurement was taken with a 10Hz video bandwidth. The EUT was tested at low, mid and high with the highest output power. Investigated up to 10th harmonic of the operating frequency or 40GHz.

Sample Calculation:

EUT Field Strength = Raw Amplitude(dBμV/m) – Amplifier Gain(dB) + Antenna Factor(dB) + Cable Loss(dB) + Filter Attenuation(dB, if used)

Power Level: As specified by the following matrix, see section 5.5 Peak Output Power

Antenna	Antenna Gain	Bandwidth (MHz)	Antenna Gain >6dBi (Antenna Gain-6dBi)	Max Allowable Conducted Power (dBm)
Panel	29	8	23	-2.62
		16		-2.41
		32		-3.00
Parabolic Dish	37.9	8	31.9	-11.52
		16		-8.49
		32		-7.90

Note: Harmonic spurious emission was performed with high pass filter.

5.2GHz band- Antenna type: Panel with maximum antenna gain 29dBi

Low Channel (8MHz Mode 1)

Frequency	Reading	Direction	Height	Polar	Antenna Loss	Cable loss	Amplifier	Corrected Reading	15.407/15.209	15.407/15.209	
GHz	(dBuV/m)	Degree	Meter	H / V	(dB)	(dB)	(dB)	(dBuV/m)	Limit (dBuV/m)	Margin	Comments
10.51	51.34	84.00	165.00	v	41.90	6.91	32.83	67.32	68.20	-0.88	Peak
10.51	51.26	35.00	134.00	h	41.90	6.91	32.83	67.24	68.20	-0.96	Peak

Emission was scanned up to 40GHz

Mid Channel (8MHz Mode 1)

Frequency	Reading	Direction	Height	Polar	Antenna Loss	Cable loss	Amplifier	Corrected Reading	15.407/15.209	15.407/15.209	
GHz	(dBuV/m)	Degree	Meter	H / V	(dB)	(dB)	(dB)	(dBuV/m)	Limit (dBuV/m)	Margin	Comments
10.60	51.24	175.00	231.00	v	41.90	6.91	32.83	67.22	68.20	-0.98	Peak
10.60	51.54	120.00	146.00	h	41.90	6.91	32.83	67.52	68.20	-0.68	Peak

Emission was scanned up to 40GHz

High Channel (8MHz Mode 1)

Frequency	Reading	Direction	Height	Polar	Antenna Loss	Cable loss	Amplifier	Corrected Reading	15.407/15.209	15.407/15.209	
GHz	(dBuV/m)	Degree	Meter	H / V	(dB)	(dB)	(dB)	(dBuV/m)	Limit (dBuV/m)	Margin	Comments
10.69	51.35	197.00	134.00	v	41.90	6.91	32.83	67.33	74.00	-6.67	Peak
10.69	50.54	134.00	156.00	h	41.90	6.91	32.83	66.52	74.00	-7.48	Peak
10.69	29.57	197.00	134.00	v	41.90	6.91	32.83	45.55	54.00	-8.45	Ave
10.69	28.68	134.00	156.00	h	41.90	6.91	32.83	44.66	54.00	-9.34	Ave

Emission was scanned up to 40GHz

Low Channel (8MHz Mode 2)

Frequency	Reading	Direction	Height	Polar	Antenna Loss	Cable loss	Amplifier	Corrected Reading	15.407/15.209	15.407/15.209	
GHz	(dBuV/m)	Degree	Meter	H / V	(dB)	(dB)	(dB)	(dBuV/m)	Limit (dBuV/m)	Margin	Comments
10.51	51.26	93.00	154.00	v	41.90	6.91	32.83	67.24	68.20	-0.96	Peak
10.51	50.57	47.00	145.00	h	41.90	6.91	32.83	66.55	68.20	-1.65	Peak

Emission was scanned up to 40GHz

Mid Channel (8MHz Mode 2)

Frequency	Reading	Direction	Height	Polar	Antenna Loss	Cable loss	Amplifier	Corrected Reading	15.407/15.209	15.407/15.209	
GHz	(dBuV/m)	Degree	Meter	H / V	(dB)	(dB)	(dB)	(dBuV/m)	Limit (dBuV/m)	Margin	Comments
10.60	51.44	167.00	156.00	v	41.90	6.91	32.83	67.42	68.20	-0.78	Peak
10.60	51.06	176.00	132.00	h	41.90	6.91	32.83	67.04	68.20	-1.16	Peak

Emission was scanned up to 40GHz

High Channel (8MHz Mode 2)

Frequency	Reading	Direction	Height	Polar	Antenna Loss	Cable loss	Amplifier	Corrected Reading	15.407/15.209	15.407/15.209	
GHz	(dBuV/m)	Degree	Meter	H / V	(dB)	(dB)	(dB)	(dBuV/m)	Limit (dBuV/m)	Margin	Comments
10.69	50.57	231.00	143.00	v	41.90	6.91	32.83	66.55	74.00	-7.45	Peak
10.69	50.12	198.00	132.00	h	41.90	6.91	32.83	66.10	74.00	-7.90	Peak
10.69	29.57	231.00	143.00	v	41.90	6.91	32.83	45.55	54.00	-8.45	Ave
10.69	28.57	198.00	132.00	h	41.90	6.91	32.83	44.55	54.00	-9.45	Ave

Emission was scanned up to 40GHz

Low Channel (8MHz Mode 3)

Frequency	Reading	Direction	Height	Polar	Antenna Loss	Cable loss	Amplifier	Corrected Reading	15.407/15.209	15.407/15.209	
GHz	(dBuV/m)	Degree	Meter	H / V	(dB)	(dB)	(dB)	(dBuV/m)	Limit (dBuV/m)	Margin	Comments
10.51	51.57	153.00	145.00	v	41.90	6.91	32.83	67.55	68.20	-0.65	Peak
10.51	50.45	135.00	187.00	h	41.90	6.91	32.83	66.43	68.20	-1.77	Peak

Emission was scanned up to 40GHz

Mid Channel (8MHz Mode 3)

Frequency	Reading	Direction	Height	Polar	Antenna Loss	Cable loss	Amplifier	Corrected Reading	15.407/15.209	15.407/15.209	
GHz	(dBuV/m)	Degree	Meter	H / V	(dB)	(dB)	(dB)	(dBuV/m)	Limit (dBuV/m)	Margin	Comments
10.6	51.45	210	176	v	41.9	6.91	32.83	67.43	68.20	-0.77	Peak
10.6	50.95	230	156	h	41.9	6.91	32.83	66.93	68.20	-1.27	Peak

Emission was scanned up to 40GHz

High Channel (8MHz Mode 3)

Frequency	Reading	Direction	Height	Polar	Antenna Loss	Cable loss	Amplifier	Corrected Reading	15.407/15.209	15.407/15.209	
GHz	(dBuV/m)	Degree	Meter	H / V	(dB)	(dB)	(dB)	(dBuV/m)	Limit (dBuV/m)	Margin	Comments
10.69	51.83	256	230	v	41.9	6.91	32.83	67.81	74.00	-6.19	Peak
10.69	50.57	187	167	h	41.9	6.91	32.83	66.55	74.00	-7.45	Peak
10.69	28.57	256	230	v	41.9	6.91	32.83	44.55	54.00	-9.45	Ave
10.69	27.84	187	167	h	41.9	6.91	32.83	43.82	54.00	-10.18	Ave

Emission was scanned up to 40GHz

Low Channel (16MHz Mode 1)

Frequency	Reading	Direction	Height	Polar	Antenna Loss	Cable loss	Amplifier	Corrected Reading	15.407/15.209	15.407/15.209	
GHz	(dBuV/m)	Degree	Meter	H / V	(dB)	(dB)	(dB)	(dBuV/m)	Limit (dBuV/m)	Margin	Comments
10.52	51.63	167.00	174.00	v	41.90	6.91	32.83	67.61	68.20	-0.59	Peak
10.52	50.56	145.00	156.00	h	41.90	6.91	32.83	66.54	68.20	-1.66	Peak

Emission was scanned up to 40GHz

Mid Channel (16MHz Mode 1)

Frequency	Reading	Direction	Height	Polar	Antenna Loss	Cable loss	Amplifier	Corrected Reading	15.407/15.209	15.407/15.209	
GHz	(dBuV/m)	Degree	Meter	H / V	(dB)	(dB)	(dB)	(dBuV/m)	Limit (dBuV/m)	Margin	Comments
10.60	51.34	210.00	176.00	v	41.90	6.91	32.83	67.32	68.20	-0.88	Peak
10.60	50.53	230.00	156.00	h	41.90	6.91	32.83	66.51	68.20	-1.69	Peak

Emission was scanned up to 40GHz

High Channel (16MHz Mode 1)

Frequency	Reading	Direction	Height	Polar	Antenna Loss	Cable loss	Amplifier	Corrected Reading	15.407/15.209	15.407/15.209	
GHz	(dBuV/m)	Degree	Meter	H / V	(dB)	(dB)	(dB)	(dBuV/m)	Limit (dBuV/m)	Margin	Comments
10.6	51.85	195	187	v	41.9	6.91	32.83	67.83	74.00	-6.17	Peak
10.6	50.57	145	134	h	41.9	6.91	32.83	66.55	74.00	-7.45	Peak
10.6	29.67	195	187	v	41.9	6.91	32.83	45.65	54.00	-8.35	Ave
10.6	28.58	145	134	h	41.9	6.91	32.83	44.56	54.00	-9.44	Ave

Emission was scanned up to 40GHz

Low Channel (16MHz Mode 2)

Frequency	Reading	Direction	Height	Polar	Antenna Loss	Cable loss	Amplifier	Corrected Reading	15.407/15.209	15.407/15.209	
GHz	(dBuV/m)	Degree	Meter	H / V	(dB)	(dB)	(dB)	(dBuV/m)	Limit (dBuV/m)	Margin	Comments
10.52	51.56	198.00	174.00	v	41.90	6.91	32.83	67.54	68.20	-0.66	Peak
10.52	50.69	165.00	156.00	h	41.90	6.91	32.83	66.67	68.20	-1.53	Peak

Emission was scanned up to 40GHz

Mid Channel (16MHz Mode 2)

Frequency	Reading	Direction	Height	Polar	Antenna Loss	Cable loss	Amplifier	Corrected Reading	15.407/15.209	15.407/15.209	
GHz	(dBuV/m)	Degree	Meter	H / V	(dB)	(dB)	(dB)	(dBuV/m)	Limit (dBuV/m)	Margin	Comments
10.60	51.24	210.00	176.00	v	41.90	6.91	32.83	67.22	68.20	-0.98	Peak
10.60	50.35	156.00	145.00	h	41.90	6.91	32.83	66.33	68.20	-1.87	Peak

Emission was scanned up to 40GHz

High Channel (16MHz Mode 2)

Frequency	Reading	Direction	Height	Polar	Antenna Loss	Cable loss	Amplifier	Corrected Reading	15.407/15.209	15.407/15.209	
GHz	(dBuV/m)	Degree	Meter	H / V	(dB)	(dB)	(dB)	(dBuV/m)	Limit (dBuV/m)	Margin	Comments
10.68	51.75	1134.00	145.00	v	41.90	6.91	32.83	67.73	74.00	-6.27	Peak
10.68	50.94	156.00	113.00	h	41.90	6.91	32.83	66.92	74.00	-7.08	Peak
10.68	29.56	1134.00	145.00	v	41.90	6.91	32.83	45.54	54.00	-8.46	Ave
10.68	27.57	156.00	113.00	h	41.90	6.91	32.83	43.55	54.00	-10.45	Ave

Emission was scanned up to 40GHz

Low Channel (16MHz Mode 3)

Frequency	Reading	Direction	Height	Polar	Antenna Loss	Cable loss	Amplifier	Corrected Reading	15.407/15.209	15.407/15.209	
GHz	(dBuV/m)	Degree	Meter	H / V	(dB)	(dB)	(dB)	(dBuV/m)	Limit (dBuV/m)	Margin	Comments
10.52	51.36	167.00	114.00	v	41.90	6.91	32.83	67.34	68.20	-0.86	Peak
10.52	50.63	123.00	113.00	h	41.90	6.91	32.83	66.61	68.20	-1.59	Peak

Emission was scanned up to 40GHz

Mid Channel (16MHz Mode 3)

Frequency	Reading	Direction	Height	Polar	Antenna Loss	Cable loss	Amplifier	Corrected Reading	15.407/15.209	15.407/15.209	
GHz	(dBuV/m)	Degree	Meter	H / V	(dB)	(dB)	(dB)	(dBuV/m)	Limit (dBuV/m)	Margin	Comments
10.60	51.73	312.00	134.00	v	41.90	6.91	32.83	67.71	68.20	-0.49	Peak
10.60	50.26	311.00	115.00	h	41.90	6.91	32.83	66.24	68.20	-1.96	Peak

Emission was scanned up to 40GHz

High Channel (16MHz Mode 3)

Frequency	Reading	Direction	Height	Polar	Antenna Loss	Cable loss	Amplifier	Corrected Reading	15.407/15.209	15.407/15.209	
GHz	(dBuV/m)	Degree	Meter	H / V	(dB)	(dB)	(dB)	(dBuV/m)	Limit (dBuV/m)	Margin	Comments
10.68	51.38	134.00	165.00	v	41.90	6.91	32.83	67.36	74.00	-6.64	Peak
10.68	50.21	156.00	132.00	h	41.90	6.91	32.83	66.19	74.00	-7.81	Peak
10.68	29.12	134.00	165.00	v	41.90	6.91	32.83	45.10	54.00	-8.90	Ave
10.68	28.46	156.00	132.00	h	41.90	6.91	32.83	44.44	54.00	-9.56	Ave

Emission was scanned up to 40GHz

Low Channel (32MHz Mode 1)

Frequency	Reading	Direction	Height	Polar	Antenna Loss	Cable loss	Amplifier	Corrected Reading	15.407/15.209	15.407/15.209	
GHz	(dBuV/m)	Degree	Meter	H / V	(dB)	(dB)	(dB)	(dBuV/m)	Limit (dBuV/m)	Margin	Comments
10.54	51.37	267	143	v	41.9	6.91	32.83	67.35	68.20	-0.85	Peak
10.54	50.42	210	134	h	41.9	6.91	32.83	66.40	68.20	-1.80	Peak

Emission was scanned up to 40GHz

Mid Channel (32MHz Mode 1)

Frequency	Reading	Direction	Height	Polar	Antenna Loss	Cable loss	Amplifier	Corrected Reading	15.407/15.209	15.407/15.209	
GHz	(dBuV/m)	Degree	Meter	H / V	(dB)	(dB)	(dB)	(dBuV/m)	Limit (dBuV/m)	Margin	Comments
10.6	51.34	187	167	v	41.9	6.91	32.83	67.32	68.20	-0.88	Peak
10.6	50.34	145	134	h	41.9	6.91	32.83	66.32	68.20	-1.88	Peak

Emission was scanned up to 40GHz

High Channel (32MHz Mode 1)

Frequency	Reading	Direction	Height	Polar	Antenna Loss	Cable loss	Amplifier	Corrected Reading	15.407/15.209	15.407/15.209	
GHz	(dBuV/m)	Degree	Meter	H / V	(dB)	(dB)	(dB)	(dBuV/m)	Limit (dBuV/m)	Margin	Comments
10.66	51.35	156	167	v	41.9	6.91	32.83	67.33	74.00	-6.67	Peak
10.66	50.71	134	134	h	41.9	6.91	32.83	66.69	74.00	-7.31	Peak
10.66	29.93	156	167	v	41.9	6.91	32.83	45.91	54.00	-8.09	Ave
10.66	28.35	156	134	h	41.9	6.91	32.83	44.33	54.00	-9.67	Ave

Emission was scanned up to 40GHz

Low Channel (32MHz Mode 2)

Frequency	Reading	Direction	Height	Polar	Antenna Loss	Cable loss	Amplifier	Corrected Reading	15.407/15.209	15.407/15.209	
GHz	(dBuV/m)	Degree	Meter	H / V	(dB)	(dB)	(dB)	(dBuV/m)	Limit (dBuV/m)	Margin	Comments
10.54	51.87	234.00	138.00	v	41.90	6.91	32.83	67.85	68.20	-0.35	Peak
10.54	50.67	156.00	143.00	h	41.90	6.91	32.83	66.65	68.20	-1.55	Peak

Emission was scanned up to 40GHz

Mid Channel (32MHz Mode 2)

Frequency	Reading	Direction	Height	Polar	Antenna Loss	Cable loss	Amplifier	Corrected Reading	15.407/15.209	15.407/15.209	
GHz	(dBuV/m)	Degree	Meter	H / V	(dB)	(dB)	(dB)	(dBuV/m)	Limit (dBuV/m)	Margin	Comments
10.60	51.80	293.00	145.00	v	41.90	6.91	32.83	67.78	68.20	-0.42	Peak
10.60	50.74	210.00	187.00	h	41.90	6.91	32.83	66.72	68.20	-1.48	Peak

Emission was scanned up to 40GHz

High Channel (32MHz Mode 2)

Frequency	Reading	Direction	Height	Polar	Antenna Loss	Cable loss	Amplifier	Corrected Reading	15.407/15.209	15.407/15.209	
GHz	(dBuV/m)	Degree	Meter	H / V	(dB)	(dB)	(dB)	(dBuV/m)	Limit (dBuV/m)	Margin	Comments
10.66	51.98	310.00	114.00	v	41.90	6.91	32.83	67.96	74.00	-6.04	Peak
10.66	50.69	234.00	117.00	h	41.90	6.91	32.83	66.67	74.00	-7.33	Peak
10.66	29.46	310.00	114.00	v	41.90	6.91	32.83	45.44	54.00	-8.56	Ave
10.66	28.54	234.00	117.00	h	41.90	6.91	32.83	44.52	54.00	-9.48	Ave

Emission was scanned up to 40GHz

Low Channel (32MHz Mode 3)

Frequency	Reading	Direction	Height	Polar	Antenna Loss	Cable loss	Amplifier	Corrected Reading	15.407/15.209	15.407/15.209	
GHz	(dBuV/m)	Degree	Meter	H / V	(dB)	(dB)	(dB)	(dBuV/m)	Limit (dBuV/m)	Margin	Comments
10.54	51.71	156	187	v	41.9	6.91	32.83	67.69	68.20	-0.51	Peak
10.54	50.25	123	134	h	41.9	6.91	32.83	66.23	68.20	-1.97	Peak

Emission was scanned up to 40GHz

Mid Channel (32MHz Mode 3)

Frequency	Reading	Direction	Height	Polar	Antenna Loss	Cable loss	Amplifier	Corrected Reading	15.407/15.209	15.407/15.209	
GHz	(dBuV/m)	Degree	Meter	H / V	(dB)	(dB)	(dB)	(dBuV/m)	Limit (dBuV/m)	Margin	Comments
10.6	51.73	310	165	v	41.9	6.91	32.83	67.71	68.20	-0.49	Peak
10.6	50.74	311	124	h	41.9	6.91	32.83	66.72	68.20	-1.48	Peak

Emission was scanned up to 40GHz

High Channel (32MHz Mode3)

Frequency	Reading	Direction	Height	Polar	Antenna Loss	Cable loss	Amplifier	Corrected Reading	15.407/15.209	15.407/15.209	
GHz	(dBuV/m)	Degree	Meter	H / V	(dB)	(dB)	(dB)	(dBuV/m)	Limit (dBuV/m)	Margin	Comments
10.66	51.63	256	165	v	41.9	6.91	32.83	67.61	74.00	-6.39	Peak
10.66	50.36	156	123	h	41.9	6.91	32.83	66.34	74.00	-7.66	Peak
10.66	29.67	256	165	v	41.9	6.91	32.83	45.65	54.00	-8.35	Ave
10.66	28.54	156	123	h	41.9	6.91	32.83	44.52	54.00	-9.48	Ave

Emission was scanned up to 40GHz

5.2GHz band- Antenna type: Parabolic Dish with maximum antenna gain 37.9 dBi

Low Channel (8MHz Mode 1)

Frequency	Reading	Direction	Height	Polar	Antenna Loss	Cable loss	Amplifier	Corrected Reading	15.407/15.209	15.407/15.209	
GHz	(dBuV/m)	Degree	Meter	H / V	(dB)	(dB)	(dB)	(dBuV/m)	Limit (dBuV/m)	Margin	Comments
10.51	51.74	228	129	v	41.9	6.91	32.83	67.72	68.20	-0.48	Peak
10.51	50.85	221	113	h	41.9	6.91	32.83	66.83	68.20	-1.37	Peak

Emission was scanned up to 40GHz

Mid Channel (8MHz Mode 1)

Frequency	Reading	Direction	Height	Polar	Antenna Loss	Cable loss	Amplifier	Corrected Reading	15.407/15.209	15.407/15.209	
GHz	(dBuV/m)	Degree	Meter	H / V	(dB)	(dB)	(dB)	(dBuV/m)	Limit (dBuV/m)	Margin	Comments
10.60	51.70	332.00	178.00	v	41.90	6.91	32.83	67.68	68.20	-0.52	Peak
10.60	50.38	221.00	145.00	h	41.90	6.91	32.83	66.36	68.20	-1.84	Peak

Emission was scanned up to 40GHz

High Channel (8MHz Mode 1)

Frequency	Reading	Direction	Height	Polar	Antenna Loss	Cable loss	Amplifier	Corrected Reading	15.407/15.209	15.407/15.209	
GHz	(dBuV/m)	Degree	Meter	H / V	(dB)	(dB)	(dB)	(dBuV/m)	Limit (dBuV/m)	Margin	Comments
10.69	51.46	345	129	v	41.9	6.91	32.83	67.44	74.00	-6.56	Peak
10.69	50.63	134	126	h	41.9	6.91	32.83	66.61	74.00	-7.39	Peak
10.69	30.43	345	129	v	41.9	6.91	32.83	46.41	54.00	-7.59	Ave
10.69	29.45	134	126	h	41.9	6.91	32.83	45.43	54.00	-8.57	Ave

Emission was scanned up to 40GHz

Low Channel (8MHz Mode 2)

Frequency	Reading	Direction	Height	Polar	Antenna Loss	Cable loss	Amplifier	Corrected Reading	15.407/15.209	15.407/15.209	
GHz	(dBuV/m)	Degree	Meter	H / V	(dB)	(dB)	(dB)	(dBuV/m)	Limit (dBuV/m)	Margin	Comments
10.51	51.53	91.00	146.00	v	41.90	6.91	32.83	67.51	68.20	-0.69	Peak
10.51	50.72	89.00	132.00	h	41.90	6.91	32.83	66.70	68.20	-1.50	Peak

Emission was scanned up to 40GHz

Mid Channel (8MHz Mode 2)

Frequency	Reading	Direction	Height	Polar	Antenna Loss	Cable loss	Amplifier	Corrected Reading	15.407/15.209	15.407/15.209	
GHz	(dBuV/m)	Degree	Meter	H / V	(dB)	(dB)	(dB)	(dBuV/m)	Limit (dBuV/m)	Margin	Comments
10.60	51.24	218.00	156.00	v	41.90	6.91	32.83	67.22	68.20	-0.98	Peak
10.60	50.64	214.00	126.00	h	41.90	6.91	32.83	66.62	68.20	-1.58	Peak

Emission was scanned up to 40GHz

High Channel (8MHz Mode 2)

Frequency	Reading	Direction	Height	Polar	Antenna Loss	Cable loss	Amplifier	Corrected Reading	15.407/15.209	15.407/15.209	
GHz	(dBuV/m)	Degree	Meter	H / V	(dB)	(dB)	(dB)	(dBuV/m)	Limit (dBuV/m)	Margin	Comments
10.69	51.27	156	143	v	41.9	6.91	32.83	67.25	74.00	-6.75	Peak
10.69	50.46	126	134	h	41.9	6.91	32.83	66.44	74.00	-7.56	Peak
10.69	29.56	156	143	v	41.9	6.91	32.83	45.54	54.00	-8.46	Ave
10.69	28.58	126	134	h	41.9	6.91	32.83	44.56	54.00	-9.44	Ave

Emission was scanned up to 40GHz

Low Channel (8MHz Mode 3)

Frequency	Reading	Direction	Height	Polar	Antenna Loss	Cable loss	Amplifier	Corrected Reading	15.407/15.209	15.407/15.209	
GHz	(dBuV/m)	Degree	Meter	H / V	(dB)	(dB)	(dB)	(dBuV/m)	Limit (dBuV/m)	Margin	Comments
10.51	51.55	356.00	117.00	v	41.90	6.91	32.83	67.53	68.20	-0.67	Peak
10.51	50.67	156.00	124.00	h	41.90	6.91	32.83	66.65	68.20	-1.55	Peak

Emission was scanned up to 40GHz

Mid Channel (8MHz Mode 3)

Frequency	Reading	Direction	Height	Polar	Antenna Loss	Cable loss	Amplifier	Corrected Reading	15.407/15.209	15.407/15.209	
GHz	(dBuV/m)	Degree	Meter	H / V	(dB)	(dB)	(dB)	(dBuV/m)	Limit (dBuV/m)	Margin	Comments
10.60	51.58	215.00	134.00	v	41.90	6.91	32.83	67.56	68.20	-0.64	Peak
10.60	50.73	126.00	127.00	h	41.90	6.91	32.83	66.71	68.20	-1.49	Peak

Emission was scanned up to 40GHz

High Channel (8MHz Mode 3)

Frequency	Reading	Direction	Height	Polar	Antenna Loss	Cable loss	Amplifier	Corrected Reading	15.407/15.209	15.407/15.209	
GHz	(dBuV/m)	Degree	Meter	H / V	(dB)	(dB)	(dB)	(dBuV/m)	Limit (dBuV/m)	Margin	Comments
10.69	51.36	317.00	115.00	v	41.90	6.91	32.83	67.34	74.00	-6.66	Peak
10.69	50.57	145.00	118.00	h	41.90	6.91	32.83	66.55	74.00	-7.45	Peak
10.69	29.57	317.00	115.00	v	41.90	6.91	32.83	45.55	54.00	-8.45	Ave
10.69	28.84	145.00	118.00	h	41.90	6.91	32.83	44.82	54.00	-9.18	Ave

Emission was scanned up to 40GHz

Low Channel (16MHz Mode 1)

Frequency	Reading	Direction	Height	Polar	Antenna Loss	Cable loss	Amplifier	Corrected Reading	15.407/15.209	15.407/15.209	
GHz	(dBuV/m)	Degree	Meter	H / V	(dB)	(dB)	(dB)	(dBuV/m)	Limit (dBuV/m)	Margin	Comments
10.52	51.46	316.00	126.00	v	41.90	6.91	32.83	67.44	68.20	-0.76	Peak
10.52	50.36	245.00	115.00	h	41.90	6.91	32.83	66.34	68.20	-1.86	Peak

Emission was scanned up to 40GHz

Mid Channel (16MHz Mode 1)

Frequency	Reading	Direction	Height	Polar	Antenna Loss	Cable loss	Amplifier	Corrected Reading	15.407/15.209	15.407/15.209	
GHz	(dBuV/m)	Degree	Meter	H / V	(dB)	(dB)	(dB)	(dBuV/m)	Limit (dBuV/m)	Margin	Comments
10.60	51.49	267.00	132.00	v	41.90	6.91	32.83	72.83	74.00	-1.18	Peak
10.60	50.17	116.00	167.00	h	41.90	6.91	32.83	72.11	74.00	-1.90	Peak

Emission was scanned up to 40GHz

High Channel (16MHz Mode 1)

Frequency	Reading	Direction	Height	Polar	Antenna Loss	Cable loss	Amplifier	Corrected Reading	15.407/15.209	15.407/15.209	
GHz	(dBuV/m)	Degree	Meter	H / V	(dB)	(dB)	(dB)	(dBuV/m)	Limit (dBuV/m)	Margin	Comments
10.68	51.75	325	167	v	41.9	6.91	32.83	67.73	74.00	-6.27	Peak
10.68	50.38	176	125	h	41.9	6.91	32.83	66.36	74.00	-7.64	Peak
10.68	29.86	325	167	v	41.9	6.91	32.83	45.84	54.00	-8.16	Ave
10.68	29.05	176	125	h	41.9	6.91	32.83	45.03	54.00	-8.97	Ave

Emission was scanned up to 40GHz

Low Channel (16MHz Mode 2)

Frequency	Reading	Direction	Height	Polar	Antenna Loss	Cable loss	Amplifier	Corrected Reading	15.407/15.209	15.407/15.209	
GHz	(dBuV/m)	Degree	Meter	H / V	(dB)	(dB)	(dB)	(dBuV/m)	Limit (dBuV/m)	Margin	Comments
10.52	51.74	91.00	146.00	v	41.90	6.91	32.83	67.72	68.20	-0.48	Peak
10.52	50.52	89.00	132.00	h	41.90	6.91	32.83	66.50	68.20	-1.70	Peak

Emission was scanned up to 40GHz

Mid Channel (16MHz Mode 2)

Frequency	Reading	Direction	Height	Polar	Antenna Loss	Cable loss	Amplifier	Corrected Reading	15.407/15.209	15.407/15.209	
GHz	(dBuV/m)	Degree	Meter	H / V	(dB)	(dB)	(dB)	(dBuV/m)	Limit (dBuV/m)	Margin	Comments
10.60	51.71	117.00	156.00	v	41.90	6.91	32.83	67.69	68.20	-0.51	Peak
10.60	50.73	156.00	134.00	h	41.90	6.91	32.83	66.71	68.20	-1.49	Peak

Emission was scanned up to 40GHz

High Channel (16MHz Mode 2)

Frequency	Reading	Direction	Height	Polar	Antenna Loss	Cable loss	Amplifier	Corrected Reading	15.407/15.209	15.407/15.209	
GHz	(dBuV/m)	Degree	Meter	H / V	(dB)	(dB)	(dB)	(dBuV/m)	Limit (dBuV/m)	Margin	Comments
10.68	51.69	217	178	v	41.9	6.91	32.83	67.67	74.00	-6.33	Peak
10.68	50.52	211	145	h	41.9	6.91	32.83	66.50	74.00	-7.50	Peak
10.68	30.13	217	178	v	41.9	6.91	32.83	46.11	54.00	-7.89	Ave
10.68	29.84	211	145	h	41.9	6.91	32.83	45.82	54.00	-8.18	Ave

Emission was scanned up to 40GHz

Low Channel (16MHz Mode 3)

Frequency	Reading	Direction	Height	Polar	Antenna Loss	Cable loss	Amplifier	Corrected Reading	15.407/15.209	15.407/15.209	
GHz	(dBuV/m)	Degree	Meter	H / V	(dB)	(dB)	(dB)	(dBuV/m)	Limit (dBuV/m)	Margin	Comments
10.52	51.26	167.00	165.00	v	41.90	6.91	32.83	67.24	68.20	-0.96	Peak
10.52	50.63	123.00	117.00	h	41.90	6.91	32.83	66.61	68.20	-1.59	Peak

Emission was scanned up to 40GHz

Mid Channel (16MHz Mode 3)

Frequency	Reading	Direction	Height	Polar	Antenna Loss	Cable loss	Amplifier	Corrected Reading	15.407/15.209	15.407/15.209	
GHz	(dBuV/m)	Degree	Meter	H / V	(dB)	(dB)	(dB)	(dBuV/m)	Limit (dBuV/m)	Margin	Comments
10.6	51.74	211	118	v	41.9	6.91	32.83	67.72	68.20	-0.48	Peak
10.6	50.63	187	114	h	41.9	6.91	32.83	66.61	68.20	-1.59	Peak

Emission was scanned up to 40GHz

High Channel (16MHz Mode 3)

Frequency	Reading	Direction	Height	Polar	Antenna Loss	Cable loss	Amplifier	Corrected Reading	15.407/15.209	15.407/15.209	
GHz	(dBuV/m)	Degree	Meter	H / V	(dB)	(dB)	(dB)	(dBuV/m)	Limit (dBuV/m)	Margin	Comments
10.68	51.25	267	176	v	41.9	6.91	32.83	67.23	74.00	-6.77	Peak
10.68	50.14	165	145	h	41.9	6.91	32.83	66.12	74.00	-7.88	Peak
10.68	30.57	267	176	v	41.9	6.91	32.83	46.55	54.00	-7.45	Ave
10.68	29.46	165	145	h	41.9	6.91	32.83	45.44	54.00	-8.56	Ave

Emission was scanned up to 40GHz

Low Channel (32MHz Mode 1)

Frequency	Reading	Direction	Height	Polar	Antenna Loss	Cable loss	Amplifier	Corrected Reading	15.407/15.209	15.407/15.209	
GHz	(dBuV/m)	Degree	Meter	H / V	(dB)	(dB)	(dB)	(dBuV/m)	Limit (dBuV/m)	Margin	Comments
10.54	51.37	176	112	v	41.9	6.91	32.83	67.35	68.20	-0.85	Peak
10.54	50.63	145	117	h	41.9	6.91	32.83	66.61	68.20	-1.59	Peak

Emission was scanned up to 40GHz

Mid Channel (32MHz Mode 1)

Frequency	Reading	Direction	Height	Polar	Antenna Loss	Cable loss	Amplifier	Corrected Reading	15.407/15.209	15.407/15.209	
GHz	(dBuV/m)	Degree	Meter	H / V	(dB)	(dB)	(dB)	(dBuV/m)	Limit (dBuV/m)	Margin	Comments
10.60	51.38	267.00	117.00	v	41.90	6.91	32.83	67.36	68.20	-0.84	Peak
10.60	50.63	211.00	119.00	h	41.90	6.91	32.83	66.61	68.20	-1.59	Peak

Emission was scanned up to 40GHz

High Channel (32MHz Mode 1)

Frequency	Reading	Direction	Height	Polar	Antenna Loss	Cable loss	Amplifier	Corrected Reading	15.407/15.209	15.407/15.209	
GHz	(dBuV/m)	Degree	Meter	H / V	(dB)	(dB)	(dB)	(dBuV/m)	Limit (dBuV/m)	Margin	Comments
10.66	51.37	118.00	115.00	v	41.90	6.91	32.83	67.35	74.00	-6.65	Peak
10.66	50.63	145.00	119.00	h	41.90	6.91	32.83	66.61	74.00	-7.39	Peak
10.66	29.74	118.00	115.00	v	41.90	6.91	32.83	45.72	54.00	-8.28	Ave
10.66	29.13	145.00	119.00	h	41.90	6.91	32.83	45.11	54.00	-8.89	Ave

Emission was scanned up to 40GHz

Low Channel (32MHz Mode 2)

Frequency	Reading	Direction	Height	Polar	Antenna Loss	Cable loss	Amplifier	Corrected Reading	15.407/15.209	15.407/15.209	
GHz	(dBuV/m)	Degree	Meter	H / V	(dB)	(dB)	(dB)	(dBuV/m)	Limit (dBuV/m)	Margin	Comments
10.54	51.29	211.00	115.00	v	41.90	6.91	32.83	67.27	68.20	-0.93	Peak
10.54	50.79	319.00	121.00	h	41.90	6.91	32.83	66.77	68.20	-1.43	Peak

Emission was scanned up to 40GHz

Mid Channel (32MHz Mode 2)

Frequency	Reading	Direction	Height	Polar	Antenna Loss	Cable loss	Amplifier	Corrected Reading	15.407/15.209	15.407/15.209	
GHz	(dBuV/m)	Degree	Meter	H / V	(dB)	(dB)	(dB)	(dBuV/m)	Limit (dBuV/m)	Margin	Comments
10.60	51.38	145.00	118.00	v	41.90	6.91	32.83	67.36	68.20	-0.84	Peak
10.60	50.62	118.00	112.00	h	41.90	6.91	32.83	66.60	68.20	-1.60	Peak

Emission was scanned up to 40GHz

High Channel (32MHz Mode 2)

Frequency	Reading	Direction	Height	Polar	Antenna Loss	Cable loss	Amplifier	Corrected Reading	15.407/15.209	15.407/15.209	
GHz	(dBuV/m)	Degree	Meter	H / V	(dB)	(dB)	(dB)	(dBuV/m)	Limit (dBuV/m)	Margin	Comments
10.66	51.39	311.00	119.00	v	41.90	6.91	32.83	67.37	74.00	-6.63	Peak
10.66	50.72	122.00	112.00	h	41.90	6.91	32.83	66.70	74.00	-7.30	Peak
10.66	30.63	311.00	119.00	v	41.90	6.91	32.83	46.61	54.00	-7.39	Ave
10.66	29.38	122.00	112.00	h	41.90	6.91	32.83	45.36	54.00	-8.64	Ave

Emission was scanned up to 40GHz

Low Channel (32MHz Mode 3)

Frequency	Reading	Direction	Height	Polar	Antenna Loss	Cable loss	Amplifier	Corrected Reading	15.407/15.209	15.407/15.209	
GHz	(dBuV/m)	Degree	Meter	H / V	(dB)	(dB)	(dB)	(dBuV/m)	Limit (dBuV/m)	Margin	Comments
10.54	51.36	211.00	117.00	v	41.90	6.91	32.83	67.34	68.20	-0.86	Peak
10.54	50.36	217.00	112.00	h	41.90	6.91	32.83	66.34	68.20	-1.86	Peak

Emission was scanned up to 40GHz

Mid Channel (32MHz Mode 3)

Frequency	Reading	Direction	Height	Polar	Antenna Loss	Cable loss	Amplifier	Corrected Reading	15.407/15.209	15.407/15.209	
GHz	(dBuV/m)	Degree	Meter	H / V	(dB)	(dB)	(dB)	(dBuV/m)	Limit (dBuV/m)	Margin	Comments
10.60	51.46	167.00	118.00	v	41.90	6.91	32.83	67.44	68.20	-0.76	Peak
10.60	50.63	112.00	132.00	h	41.90	6.91	32.83	66.61	68.20	-1.59	Peak

Emission was scanned up to 40GHz

High Channel (32MHz Mode3)

Frequency	Reading	Direction	Height	Polar	Antenna Loss	Cable loss	Amplifier	Corrected Reading	15.407/15.209	15.407/15.209	
GHz	(dBuV/m)	Degree	Meter	H / V	(dB)	(dB)	(dB)	(dBuV/m)	Limit (dBuV/m)	Margin	Comments
10.66	51.46	145.00	116.00	v	41.90	6.91	32.83	67.44	74.00	-6.56	Peak
10.66	50.21	116.00	112.00	h	41.90	6.91	32.83	66.19	74.00	-7.81	Peak
10.66	30.63	145.00	116.00	v	41.90	6.91	32.83	46.61	54.00	-7.39	Ave
10.66	29.58	116.00	112.00	h	41.90	6.91	32.83	45.56	54.00	-8.44	Ave

Emission was scanned up to 40GHz

5.4GHz band- Antenna type: Panel with maximum antenna gain 28dBi

Low Channel (8MHz Mode 1)

Frequency	Reading	Direction	Height	Polar	Antenna Loss	Cable loss	Amplifier	Corrected Reading	15.407/15.209	15.407/15.209	
GHz	(dBuV/m)	Degree	Meter	H / V	(dB)	(dB)	(dB)	(dBuV/m)	Limit (dBuV/m)	Margin	Comments
10.95	52.47	67.00	134.00	v	41.90	6.91	32.83	68.45	74.00	-5.55	Peak
10.95	51.36	23.00	112.00	h	41.90	6.91	32.83	67.34	74.00	-6.66	Peak
10.95	29.74	67.00	134.00	v	41.90	6.91	32.83	45.72	54.00	-8.28	Ave
10.95	27.69	23.00	112.00	h	41.90	6.91	32.83	43.67	54.00	-10.33	Ave

Emission was scanned up to 40GHz

Mid Channel (8MHz Mode 1)

Frequency	Reading	Direction	Height	Polar	Antenna Loss	Cable loss	Amplifier	Corrected Reading	15.407/15.209	15.407/15.209	
GHz	(dBuV/m)	Degree	Meter	H / V	(dB)	(dB)	(dB)	(dBuV/m)	Limit (dBuV/m)	Margin	Comments
11.19	51.74	156.00	210.00	v	41.70	7.17	32.70	67.91	74.00	-6.09	Peak
11.19	50.63	145.00	134.00	h	41.70	7.17	32.70	66.80	74.00	-7.20	Peak
11.19	29.45	156.00	210.00	v	41.70	7.17	32.70	45.62	54.00	-8.38	Ave
11.19	28.52	145.00	134.00	h	41.70	7.17	32.70	44.69	54.00	-9.31	Ave

Emission was scanned up to 40GHz

High Channel (8MHz Mode 1)

Frequency	Reading	Direction	Height	Polar	Antenna Loss	Cable loss	Amplifier	Corrected Reading	15.407/15.209	15.407/15.209	
GHz	(dBuV/m)	Degree	Meter	H / V	(dB)	(dB)	(dB)	(dBuV/m)	Limit (dBuV/m)	Margin	Comments
11.44	52.78	156.00	110.00	v	41.70	7.17	32.70	68.95	74.00	-5.05	Peak
11.44	51.39	134.00	123.00	h	41.70	7.17	32.70	67.56	74.00	-6.44	Peak
11.44	28.46	156.00	110.00	v	41.70	7.17	32.70	44.63	54.00	-9.37	Ave
11.44	27.96	134.00	123.00	h	41.70	7.17	32.70	44.13	54.00	-9.87	Ave

Emission was scanned up to 40GHz

Low Channel (8MHz Mode 2)

Frequency	Reading	Direction	Height	Polar	Antenna Loss	Cable loss	Amplifier	Corrected Reading	15.407/15.209	15.407/15.209	
GHz	(dBuV/m)	Degree	Meter	H / V	(dB)	(dB)	(dB)	(dBuV/m)	Limit (dBuV/m)	Margin	Comments
10.95	51.56	67.00	134.00	v	41.90	6.91	32.83	67.54	74.00	-6.46	Peak
10.95	50.19	23.00	112.00	h	41.90	6.91	32.83	66.17	74.00	-7.83	Peak
10.95	29.34	67.00	134.00	v	41.90	6.91	32.83	45.32	54.00	-8.68	Ave
10.95	28.19	23.00	112.00	h	41.90	6.91	32.83	44.17	54.00	-9.83	Ave

Emission was scanned up to 40GHz

Mid Channel (8MHz Mode 2)

Frequency	Reading	Direction	Height	Polar	Antenna Loss	Cable loss	Amplifier	Corrected Reading	15.407/15.209	15.407/15.209	
GHz	(dBuV/m)	Degree	Meter	H / V	(dB)	(dB)	(dB)	(dBuV/m)	Limit (dBuV/m)	Margin	Comments
11.19	52.71	178.00	156.00	v	41.70	7.17	32.70	68.88	74.00	-5.12	Peak
11.19	52.10	198.00	134.00	h	41.70	7.17	32.70	68.27	74.00	-5.73	Peak
11.19	29.95	178.00	156.00	v	41.70	7.17	32.70	46.12	54.00	-7.88	Ave
11.19	28.46	198.00	134.00	h	41.70	7.17	32.70	44.63	54.00	-9.37	Ave

Emission was scanned up to 40GHz

High Channel (8MHz Mode 2)

Frequency	Reading	Direction	Height	Polar	Antenna Loss	Cable loss	Amplifier	Corrected Reading	15.407/15.209	15.407/15.209	
GHz	(dBuV/m)	Degree	Meter	H / V	(dB)	(dB)	(dB)	(dBuV/m)	Limit (dBuV/m)	Margin	Comments
11.44	51.10	187.00	198.00	v	41.70	7.17	32.70	67.27	74.00	-6.73	Peak
11.44	50.83	124.00	135.00	h	41.70	7.17	32.70	67.00	74.00	-7.00	Peak
11.44	29.10	187.00	198.00	v	41.70	7.17	32.70	45.27	54.00	-8.73	Ave
11.44	28.37	124.00	135.00	h	41.70	7.17	32.70	44.54	54.00	-9.46	Ave

Emission was scanned up to 40GHz

Low Channel (8MHz Mode 3)

Frequency	Reading	Direction	Height	Polar	Antenna Loss	Cable loss	Amplifier	Corrected Reading	15.407/15.209	15.407/15.209	
GHz	(dBuV/m)	Degree	Meter	H / V	(dB)	(dB)	(dB)	(dBuV/m)	Limit (dBuV/m)	Margin	Comments
10.95	50.86	197.00	117.00	v	41.90	6.91	32.83	66.84	74.00	-7.16	Peak
10.95	50.36	124.00	112.00	h	41.90	6.91	32.83	66.34	74.00	-7.66	Peak
10.95	28.74	197.00	117.00	v	41.90	6.91	32.83	44.72	54.00	-9.28	Ave
10.95	28.42	124.00	112.00	h	41.90	6.91	32.83	44.40	54.00	-9.60	Ave

Emission was scanned up to 40GHz

Mid Channel (8MHz Mode 3)

Frequency	Reading	Direction	Height	Polar	Antenna Loss	Cable loss	Amplifier	Corrected Reading	15.407/15.209	15.407/15.209	
GHz	(dBuV/m)	Degree	Meter	H / V	(dB)	(dB)	(dB)	(dBuV/m)	Limit (dBuV/m)	Margin	Comments
11.19	52.63	320.00	198.00	v	41.70	7.17	32.70	68.80	74.00	-5.20	Peak
11.19	51.35	311.00	127.00	h	41.70	7.17	32.70	67.52	74.00	-6.48	Peak
11.19	29.19	320.00	198.00	v	41.70	7.17	32.70	45.36	54.00	-8.64	Ave
11.19	28.58	311.00	127.00	h	41.70	7.17	32.70	44.75	54.00	-9.25	Ave

Emission was scanned up to 40GHz

High Channel (8MHz Mode 3)

Frequency	Reading	Direction	Height	Polar	Antenna Loss	Cable loss	Amplifier	Corrected Reading	15.407/15.209	15.407/15.209	
GHz	(dBuV/m)	Degree	Meter	H / V	(dB)	(dB)	(dB)	(dBuV/m)	Limit (dBuV/m)	Margin	Comments
11.44	52.51	234.00	116.00	v	41.70	7.17	32.70	68.68	74.00	-5.32	Peak
11.44	51.92	156.00	113.00	h	41.70	7.17	32.70	68.09	74.00	-5.91	Peak
11.44	29.12	234.00	116.00	v	41.70	7.17	32.70	45.29	54.00	-8.71	Ave
11.44	28.38	156.00	113.00	h	41.70	7.17	32.70	44.55	54.00	-9.45	Ave

Emission was scanned up to 40GHz

Low Channel (16MHz Mode 1)

Frequency	Reading	Direction	Height	Polar	Antenna Loss	Cable loss	Amplifier	Corrected Reading	15.407/15.209	15.407/15.209	
GHz	(dBuV/m)	Degree	Meter	H / V	(dB)	(dB)	(dB)	(dBuV/m)	Limit (dBuV/m)	Margin	Comments
10.96	51.37	187.00	187.00	v	41.90	6.91	32.83	67.35	74.00	-6.65	Peak
10.96	50.76	145.00	112.00	h	41.90	6.91	32.83	66.74	74.00	-7.26	Peak
10.96	29.48	187.00	187.00	v	41.90	6.91	32.83	45.46	54.00	-8.54	Ave
10.96	28.39	145.00	112.00	h	41.90	6.91	32.83	44.37	54.00	-9.63	Ave

Emission was scanned up to 40GHz

Mid Channel (16MHz Mode 1)

Frequency	Reading	Direction	Height	Polar	Antenna Loss	Cable loss	Amplifier	Corrected Reading	15.407/15.209	15.407/15.209	
GHz	(dBuV/m)	Degree	Meter	H / V	(dB)	(dB)	(dB)	(dBuV/m)	Limit (dBuV/m)	Margin	Comments
11.19	51.46	290.00	118.00	v	41.70	7.17	32.70	67.63	74.00	-6.37	Peak
11.19	50.21	211.00	112.00	h	41.70	7.17	32.70	66.38	74.00	-7.62	Peak
11.19	29.64	290.00	118.00	v	41.70	7.17	32.70	45.81	54.00	-8.19	Ave
11.19	28.14	211.00	112.00	h	41.70	7.17	32.70	44.31	54.00	-9.69	Ave

Emission was scanned up to 40GHz

High Channel (16MHz Mode 1)

Frequency	Reading	Direction	Height	Polar	Antenna Loss	Cable loss	Amplifier	Corrected Reading	15.407/15.209	15.407/15.209	
GHz	(dBuV/m)	Degree	Meter	H / V	(dB)	(dB)	(dB)	(dBuV/m)	Limit (dBuV/m)	Margin	Comments
11.43	51.35	187.00	119.00	v	41.70	7.17	32.70	67.52	74.00	-6.48	Peak
11.43	50.63	145.00	115.00	h	41.70	7.17	32.70	66.80	74.00	-7.20	Peak
11.43	29.46	187.00	119.00	v	41.70	7.17	32.70	45.63	54.00	-8.37	Ave
11.43	28.64	145.00	115.00	h	41.70	7.17	32.70	44.81	54.00	-9.19	Ave

Emission was scanned up to 40GHz

Low Channel (16MHz Mode 2)

Frequency	Reading	Direction	Height	Polar	Antenna Loss	Cable loss	Amplifier	Corrected Reading	15.407/15.209	15.407/15.209	
GHz	(dBuV/m)	Degree	Meter	H / V	(dB)	(dB)	(dB)	(dBuV/m)	Limit (dBuV/m)	Margin	Comments
10.96	52.84	210.00	119.00	v	41.90	6.91	32.83	68.82	74.00	-5.18	Peak
10.96	51.37	211.00	112.00	h	41.90	6.91	32.83	67.35	74.00	-6.65	Peak
10.96	29.19	210.00	119.00	v	41.90	6.91	32.83	45.17	54.00	-8.83	Ave
10.96	28.51	211.00	112.00	h	41.90	6.91	32.83	44.49	54.00	-9.51	Ave

Emission was scanned up to 40GHz

Mid Channel (16MHz Mode 2)

Frequency	Reading	Direction	Height	Polar	Antenna Loss	Cable loss	Amplifier	Corrected Reading	15.407/15.209	15.407/15.209	
GHz	(dBuV/m)	Degree	Meter	H / V	(dB)	(dB)	(dB)	(dBuV/m)	Limit (dBuV/m)	Margin	Comments
11.19	51.63	256.00	123.00	v	41.70	7.17	32.70	67.80	74.00	-6.20	Peak
11.19	50.53	211.00	187.00	h	41.70	7.17	32.70	66.70	74.00	-7.30	Peak
11.19	28.52	256.00	123.00	v	41.70	7.17	32.70	44.69	54.00	-9.31	Ave
11.19	28.23	211.00	187.00	h	41.70	7.17	32.70	44.40	54.00	-9.60	Ave

Emission was scanned up to 40GHz

High Channel (16MHz Mode 2)

Frequency	Reading	Direction	Height	Polar	Antenna Loss	Cable loss	Amplifier	Corrected Reading	15.407/15.209	15.407/15.209	
GHz	(dBuV/m)	Degree	Meter	H / V	(dB)	(dB)	(dB)	(dBuV/m)	Limit (dBuV/m)	Margin	Comments
11.43	51.85	354.00	154.00	v	41.70	7.17	32.70	68.02	74.00	-5.98	Peak
11.43	50.74	245.00	123.00	h	41.70	7.17	32.70	66.91	74.00	-7.09	Peak
11.43	29.42	354.00	154.00	v	41.70	7.17	32.70	45.59	54.00	-8.41	Ave
11.43	28.51	245.00	123.00	h	41.70	7.17	32.70	44.68	54.00	-9.32	Ave

Emission was scanned up to 40GHz

Low Channel (16MHz Mode 3)

Frequency	Reading	Direction	Height	Polar	Antenna Loss	Cable loss	Amplifier	Corrected Reading	15.407/15.209	15.407/15.209	
GHz	(dBuV/m)	Degree	Meter	H / V	(dB)	(dB)	(dB)	(dBuV/m)	Limit (dBuV/m)	Margin	Comments
10.96	51.82	256.00	178.00	v	41.90	6.91	32.83	67.80	74.00	-6.20	Peak
10.96	50.73	267.00	123.00	h	41.90	6.91	32.83	66.71	74.00	-7.29	Peak
10.96	29.73	256.00	178.00	v	41.90	6.91	32.83	45.71	54.00	-8.29	Ave
10.96	28.47	267.00	123.00	h	41.90	6.91	32.83	44.45	54.00	-9.55	Ave

Emission was scanned up to 40GHz

Mid Channel (16MHz Mode 3)

Frequency	Reading	Direction	Height	Polar	Antenna Loss	Cable loss	Amplifier	Corrected Reading	15.407/15.209	15.407/15.209	
GHz	(dBuV/m)	Degree	Meter	H / V	(dB)	(dB)	(dB)	(dBuV/m)	Limit (dBuV/m)	Margin	Comments
11.19	51.63	256.00	176.00	v	41.70	7.17	32.70	67.80	74.00	-6.20	Peak
11.19	50.15	211.00	134.00	h	41.70	7.17	32.70	66.32	74.00	-7.68	Peak
11.19	29.26	256.00	176.00	v	41.70	7.17	32.70	45.43	54.00	-8.57	Ave
11.19	28.47	211.00	134.00	h	41.70	7.17	32.70	44.64	54.00	-9.36	Ave

Emission was scanned up to 40GHz

High Channel (16MHz Mode 3)

Frequency	Reading	Direction	Height	Polar	Antenna Loss	Cable loss	Amplifier	Corrected Reading	15.407/15.209	15.407/15.209	
GHz	(dBuV/m)	Degree	Meter	H / V	(dB)	(dB)	(dB)	(dBuV/m)	Limit (dBuV/m)	Margin	Comments
11.43	51.74	267.00	165.00	v	41.70	7.17	32.70	67.91	74.00	-6.09	Peak
11.43	50.22	214.00	123.00	h	41.70	7.17	32.70	66.39	74.00	-7.61	Peak
11.43	28.45	267.00	165.00	v	41.70	7.17	32.70	44.62	54.00	-9.38	Ave
11.43	28.19	214.00	123.00	h	41.70	7.17	32.70	44.36	54.00	-9.64	Ave

Emission was scanned up to 40GHz

Low Channel (32MHz Mode 1)

Frequency	Reading	Direction	Height	Polar	Antenna Loss	Cable loss	Amplifier	Corrected Reading	15.407/15.209	15.407/15.209	
GHz	(dBuV/m)	Degree	Meter	H / V	(dB)	(dB)	(dB)	(dBuV/m)	Limit (dBuV/m)	Margin	Comments
10.96	51.94	57.00	178.00	v	41.90	6.91	32.83	67.92	74.00	-6.08	Peak
10.96	50.83	24.00	143.00	h	41.90	6.91	32.83	66.81	74.00	-7.19	Peak
10.96	29.10	57.00	178.00	v	41.90	6.91	32.83	45.08	54.00	-8.92	Ave
10.96	28.68	24.00	143.00	h	41.90	6.91	32.83	44.66	54.00	-9.34	Ave

Emission was scanned up to 40GHz

Mid Channel (32MHz Mode 1)

Frequency	Reading	Direction	Height	Polar	Antenna Loss	Cable loss	Amplifier	Corrected Reading	15.407/15.209	15.407/15.209	
GHz	(dBuV/m)	Degree	Meter	H / V	(dB)	(dB)	(dB)	(dBuV/m)	Limit (dBuV/m)	Margin	Comments
11.19	51.83	219.00	167.00	v	41.70	7.17	32.70	68.00	74.00	-6.00	Peak
11.19	50.92	234.00	126.00	h	41.70	7.17	32.70	67.09	74.00	-6.91	Peak
11.19	29.81	219.00	167.00	v	41.70	7.17	32.70	45.98	54.00	-8.02	Ave
11.19	28.71	234.00	126.00	h	41.70	7.17	32.70	44.88	54.00	-9.12	Ave

Emission was scanned up to 40GHz

High Channel (32MHz Mode 1)

Frequency	Reading	Direction	Height	Polar	Antenna Loss	Cable loss	Amplifier	Corrected Reading	15.407/15.209	15.407/15.209	
GHz	(dBuV/m)	Degree	Meter	H / V	(dB)	(dB)	(dB)	(dBuV/m)	Limit (dBuV/m)	Margin	Comments
11.43	52.63	189.00	178.00	v	41.70	7.17	32.70	68.80	74.00	-5.20	Peak
11.43	51.83	156.00	123.00	h	41.70	7.17	32.70	68.00	74.00	-6.00	Peak
11.43	29.50	189.00	178.00	v	41.70	7.17	32.70	45.67	54.00	-8.33	Ave
11.43	28.54	156.00	123.00	h	41.70	7.17	32.70	44.71	54.00	-9.29	Ave

Emission was scanned up to 40GHz

Low Channel (32MHz Mode 2)

Frequency	Reading	Direction	Height	Polar	Antenna Loss	Cable loss	Amplifier	Corrected Reading	15.407/15.209	15.407/15.209	
GHz	(dBuV/m)	Degree	Meter	H / V	(dB)	(dB)	(dB)	(dBuV/m)	Limit (dBuV/m)	Margin	Comments
10.96	50.95	216.00	145.00	v	41.90	6.91	32.83	66.93	74.00	-7.07	Peak
10.96	50.25	267.00	176.00	h	41.90	6.91	32.83	66.23	74.00	-7.77	Peak
10.96	29.47	216.00	145.00	v	41.90	6.91	32.83	45.45	54.00	-8.55	Ave
10.96	28.94	267.00	176.00	h	41.90	6.91	32.83	44.92	54.00	-9.08	Ave

Emission was scanned up to 40GHz

Mid Channel (32MHz Mode 2)

Frequency	Reading	Direction	Height	Polar	Antenna Loss	Cable loss	Amplifier	Corrected Reading	15.407/15.209	15.407/15.209	
GHz	(dBuV/m)	Degree	Meter	H / V	(dB)	(dB)	(dB)	(dBuV/m)	Limit (dBuV/m)	Margin	Comments
11.19	51.73	267.00	198.00	v	41.70	7.17	32.70	67.90	74.00	-6.10	Peak
11.19	50.63	235.00	112.00	h	41.70	7.17	32.70	66.80	74.00	-7.20	Peak
11.19	29.57	267.00	198.00	v	41.70	7.17	32.70	45.74	54.00	-8.26	Ave
11.19	28.91	235.00	112.00	h	41.70	7.17	32.70	45.08	54.00	-8.92	Ave

Emission was scanned up to 40GHz

High Channel (32MHz Mode 2)

Frequency	Reading	Direction	Height	Polar	Antenna Loss	Cable loss	Amplifier	Corrected Reading	15.407/15.209	15.407/15.209	
GHz	(dBuV/m)	Degree	Meter	H / V	(dB)	(dB)	(dB)	(dBuV/m)	Limit (dBuV/m)	Margin	Comments
11.43	51.94	278.00	156.00	v	41.70	7.17	32.70	68.11	74.00	-5.89	Peak
11.43	50.63	256.00	134.00	h	41.70	7.17	32.70	66.80	74.00	-7.20	Peak
11.43	29.46	278.00	156.00	v	41.70	7.17	32.70	45.63	54.00	-8.37	Ave
11.43	28.45	256.00	134.00	h	41.70	7.17	32.70	44.62	54.00	-9.38	Ave

Emission was scanned up to 40GHz

Low Channel (32MHz Mode 3)

Frequency	Reading	Direction	Height	Polar	Antenna Loss	Cable loss	Amplifier	Corrected Reading	15.407/15.209	15.407/15.209	
GHz	(dBuV/m)	Degree	Meter	H / V	(dB)	(dB)	(dB)	(dBuV/m)	Limit (dBuV/m)	Margin	Comments
10.96	51.73	278.00	189.00	v	41.90	6.91	32.83	67.71	74.00	-6.29	Peak
10.96	50.62	235.00	146.00	h	41.90	6.91	32.83	66.60	74.00	-7.40	Peak
10.96	29.46	278.00	189.00	v	41.90	6.91	32.83	45.44	54.00	-8.56	Ave
10.96	28.52	235.00	146.00	h	41.90	6.91	32.83	44.50	54.00	-9.50	Ave

Emission was scanned up to 40GHz

Mid Channel (32MHz Mode 3)

Frequency	Reading	Direction	Height	Polar	Antenna Loss	Cable loss	Amplifier	Corrected Reading	15.407/15.209	15.407/15.209	
GHz	(dBuV/m)	Degree	Meter	H / V	(dB)	(dB)	(dB)	(dBuV/m)	Limit (dBuV/m)	Margin	Comments
11.19	52.51	145.00	173.00	v	41.70	7.17	32.70	68.68	74.00	-5.32	Peak
11.19	51.94	145.00	125.00	h	41.70	7.17	32.70	68.11	74.00	-5.89	Peak
11.19	29.47	145.00	173.00	v	41.70	7.17	32.70	45.64	54.00	-8.36	Ave
11.19	28.63	145.00	125.00	h	41.70	7.17	32.70	44.80	54.00	-9.20	Ave

Emission was scanned up to 40GHz

High Channel (32MHz Mode3)

Frequency	Reading	Direction	Height	Polar	Antenna Loss	Cable loss	Amplifier	Corrected Reading	15.407/15.209	15.407/15.209	
GHz	(dBuV/m)	Degree	Meter	H / V	(dB)	(dB)	(dB)	(dBuV/m)	Limit (dBuV/m)	Margin	Comments
11.43	52.35	236.00	135.00	v	41.70	7.17	32.70	68.52	74.00	-5.48	Peak
11.43	51.27	156.00	112.00	h	41.70	7.17	32.70	67.44	74.00	-6.56	Peak
11.43	29.58	236.00	135.00	v	41.70	7.17	32.70	45.75	54.00	-8.25	Ave
11.43	28.73	156.00	112.00	h	41.70	7.17	32.70	44.90	54.00	-9.10	Ave

Emission was scanned up to 40GHz

5.4GHz band- Antenna type: Parabolic Dish with maximum antenna gain 37.5 dBi

Low Channel (8MHz Mode 1)

Frequency	Reading	Direction	Height	Polar	Antenna Loss	Cable loss	Amplifier	Corrected Reading	15.407/15.209	15.407/15.209	
GHz	(dBuV/m)	Degree	Meter	H / V	(dB)	(dB)	(dB)	(dBuV/m)	Limit (dBuV/m)	Margin	Comments
10.95	52.62	156.00	113.00	v	41.90	6.91	32.83	68.60	74.00	-5.40	Peak
10.95	51.35	112.00	112.00	h	41.90	6.91	32.83	67.33	74.00	-6.67	Peak
10.95	30.52	156.00	113.00	v	41.90	6.91	32.83	46.50	54.00	-7.50	Ave
10.95	29.53	112.00	112.00	h	41.90	6.91	32.83	45.51	54.00	-8.49	Ave

Emission was scanned up to 40GHz

Mid Channel (8MHz Mode 1)

Frequency	Reading	Direction	Height	Polar	Antenna Loss	Cable loss	Amplifier	Corrected Reading	15.407/15.209	15.407/15.209	
GHz	(dBuV/m)	Degree	Meter	H / V	(dB)	(dB)	(dB)	(dBuV/m)	Limit (dBuV/m)	Margin	Comments
11.19	56.61	256.00	114.00	v	41.70	7.17	32.70	72.78	74.00	-1.22	Peak
11.19	51.92	112.00	114.00	h	41.70	7.17	32.70	68.09	74.00	-5.91	Peak
11.19	30.91	256.00	114.00	v	41.70	7.17	32.70	47.08	54.00	-6.92	Ave
11.19	29.71	112.00	114.00	h	41.70	7.17	32.70	45.88	54.00	-8.12	Ave

Emission was scanned up to 40GHz

High Channel (8MHz Mode 1)

Frequency	Reading	Direction	Height	Polar	Antenna Loss	Cable loss	Amplifier	Corrected Reading	15.407/15.209	15.407/15.209	
GHz	(dBuV/m)	Degree	Meter	H / V	(dB)	(dB)	(dB)	(dBuV/m)	Limit (dBuV/m)	Margin	Comments
11.44	52.81	215.00	167.00	v	41.70	7.17	32.70	68.98	74.00	-5.02	Peak
11.44	52.19	123.00	137.00	h	41.70	7.17	32.70	68.36	74.00	-5.64	Peak
11.44	29.91	215.00	167.00	v	41.70	7.17	32.70	46.08	54.00	-7.92	Ave
11.44	29.83	123.00	137.00	h	41.70	7.17	32.70	46.00	54.00	-8.00	Ave

Emission was scanned up to 40GHz

Low Channel (8MHz Mode 2)

Frequency	Reading	Direction	Height	Polar	Antenna Loss	Cable loss	Amplifier	Corrected Reading	15.407/15.209	15.407/15.209	
GHz	(dBuV/m)	Degree	Meter	H / V	(dB)	(dB)	(dB)	(dBuV/m)	Limit (dBuV/m)	Margin	Comments
10.95	51.81	91.00	146.00	v	41.90	6.91	32.83	67.79	74.00	-6.21	Peak
10.95	50.62	89.00	132.00	h	41.90	6.91	32.83	66.60	74.00	-7.40	Peak
10.95	29.57	91.00	146.00	v	41.90	6.91	32.83	45.55	54.00	-8.45	Ave
10.95	29.19	89.00	132.00	h	41.90	6.91	32.83	45.17	54.00	-8.83	Ave

Emission was scanned up to 40GHz

Mid Channel (8MHz Mode 2)

Frequency	Reading	Direction	Height	Polar	Antenna Loss	Cable loss	Amplifier	Corrected Reading	15.407/15.209	15.407/15.209	
GHz	(dBuV/m)	Degree	Meter	H / V	(dB)	(dB)	(dB)	(dBuV/m)	Limit (dBuV/m)	Margin	Comments
11.19	52.81	127.00	115.00	v	41.70	7.17	32.70	68.98	74.00	-5.02	Peak
11.19	51.82	216.00	112.00	h	41.70	7.17	32.70	67.99	74.00	-6.01	Peak
11.19	29.88	127.00	115.00	v	41.70	7.17	32.70	46.05	54.00	-7.95	Ave
11.19	29.62	216.00	112.00	h	41.70	7.17	32.70	45.79	54.00	-8.21	Ave

Emission was scanned up to 40GHz

High Channel (8MHz Mode 2)

Frequency	Reading	Direction	Height	Polar	Antenna Loss	Cable loss	Amplifier	Corrected Reading	15.407/15.209	15.407/15.209	
GHz	(dBuV/m)	Degree	Meter	H / V	(dB)	(dB)	(dB)	(dBuV/m)	Limit (dBuV/m)	Margin	Comments
11.44	52.61	267.00	124.00	v	41.70	7.17	32.70	68.78	74.00	-5.22	Peak
11.44	51.05	221.00	117.00	h	41.70	7.17	32.70	67.22	74.00	-6.78	Peak
11.44	30.62	267.00	124.00	v	41.70	7.17	32.70	46.79	54.00	-7.21	Ave
11.44	29.73	221.00	117.00	h	41.70	7.17	32.70	45.90	54.00	-8.10	Ave

Emission was scanned up to 40GHz

Low Channel (8MHz Mode 3)

Frequency	Reading	Direction	Height	Polar	Antenna Loss	Cable loss	Amplifier	Corrected Reading	15.407/15.209	15.407/15.209	
GHz	(dBuV/m)	Degree	Meter	H / V	(dB)	(dB)	(dB)	(dBuV/m)	Limit (dBuV/m)	Margin	Comments
10.95	52.35	316.00	116.00	v	41.90	6.91	32.83	68.33	74.00	-5.67	Peak
10.95	51.95	311.00	113.00	h	41.90	6.91	32.83	67.93	74.00	-6.07	Peak
10.95	29.87	316.00	116.00	v	41.90	6.91	32.83	45.85	54.00	-8.15	Ave
10.95	29.48	311.00	113.00	h	41.90	6.91	32.83	45.46	54.00	-8.54	Ave

Emission was scanned up to 40GHz

Mid Channel (8MHz Mode 3)

Frequency	Reading	Direction	Height	Polar	Antenna Loss	Cable loss	Amplifier	Corrected Reading	15.407/15.209	15.407/15.209	
GHz	(dBuV/m)	Degree	Meter	H / V	(dB)	(dB)	(dB)	(dBuV/m)	Limit (dBuV/m)	Margin	Comments
11.19	52.52	311.00	156.00	v	41.70	7.17	32.70	68.69	74.00	-5.31	Peak
11.19	51.94	321.00	112.00	h	41.70	7.17	32.70	68.11	74.00	-5.89	Peak
11.19	29.56	311.00	156.00	v	41.70	7.17	32.70	45.73	54.00	-8.27	Ave
11.19	29.14	321.00	112.00	h	41.70	7.17	32.70	45.31	54.00	-8.69	Ave

Emission was scanned up to 40GHz

High Channel (8MHz Mode 3)

Frequency	Reading	Direction	Height	Polar	Antenna Loss	Cable loss	Amplifier	Corrected Reading	15.407/15.209	15.407/15.209	
GHz	(dBuV/m)	Degree	Meter	H / V	(dB)	(dB)	(dB)	(dBuV/m)	Limit (dBuV/m)	Margin	Comments
11.44	52.71	211.00	116.00	v	41.70	7.17	32.70	68.88	74.00	-5.12	Peak
11.44	51.82	122.00	112.00	h	41.70	7.17	32.70	67.99	74.00	-6.01	Peak
11.44	30.54	211.00	116.00	v	41.70	7.17	32.70	46.71	54.00	-7.29	Ave
11.44	29.85	122.00	112.00	h	41.70	7.17	32.70	46.02	54.00	-7.98	Ave

Emission was scanned up to 40GHz

Low Channel (16MHz Mode 1)

Frequency	Reading	Direction	Height	Polar	Antenna Loss	Cable loss	Amplifier	Corrected Reading	15.407/15.209	15.407/15.209	
GHz	(dBuV/m)	Degree	Meter	H / V	(dB)	(dB)	(dB)	(dBuV/m)	Limit (dBuV/m)	Margin	Comments
10.96	51.48	322.00	143.00	v	41.90	6.91	32.83	67.46	74.00	-6.54	Peak
10.96	50.83	128.00	112.00	h	41.90	6.91	32.83	66.81	74.00	-7.19	Peak
10.96	29.87	322.00	143.00	v	41.90	6.91	32.83	45.85	54.00	-8.15	Ave
10.96	28.72	128.00	112.00	h	41.90	6.91	32.83	44.70	54.00	-9.30	Ave

Emission was scanned up to 40GHz

Mid Channel (16MHz Mode 1)

Frequency	Reading	Direction	Height	Polar	Antenna Loss	Cable loss	Amplifier	Corrected Reading	15.407/15.209	15.407/15.209	
GHz	(dBuV/m)	Degree	Meter	H / V	(dB)	(dB)	(dB)	(dBuV/m)	Limit (dBuV/m)	Margin	Comments
11.19	52.76	165.00	112.00	v	41.70	7.17	32.70	68.93	74.00	-5.07	Peak
11.19	51.73	1145.00	132.00	h	41.70	7.17	32.70	67.90	74.00	-6.10	Peak
11.19	29.62	165.00	112.00	v	41.70	7.17	32.70	45.79	54.00	-8.21	Ave
11.19	28.62	1145.00	132.00	h	41.70	7.17	32.70	44.79	54.00	-9.21	Ave

Emission was scanned up to 40GHz

High Channel (16MHz Mode 1)

Frequency	Reading	Direction	Height	Polar	Antenna Loss	Cable loss	Amplifier	Corrected Reading	15.407/15.209	15.407/15.209	
GHz	(dBuV/m)	Degree	Meter	H / V	(dB)	(dB)	(dB)	(dBuV/m)	Limit (dBuV/m)	Margin	Comments
11.43	52.63	156.00	112.00	v	41.70	7.17	32.70	68.80	74.00	-5.20	Peak
11.43	51.39	112.00	115.00	h	41.70	7.17	32.70	67.56	74.00	-6.44	Peak
11.43	30.24	156.00	112.00	v	41.70	7.17	32.70	46.41	54.00	-7.59	Ave
11.43	29.41	112.00	115.00	h	41.70	7.17	32.70	45.58	54.00	-8.42	Ave

Emission was scanned up to 40GHz

Low Channel (16MHz Mode 2)

Frequency	Reading	Direction	Height	Polar	Antenna Loss	Cable loss	Amplifier	Corrected Reading	15.407/15.209	15.407/15.209	
GHz	(dBuV/m)	Degree	Meter	H / V	(dB)	(dB)	(dB)	(dBuV/m)	Limit (dBuV/m)	Margin	Comments
10.96	52.47	54.00	115.00	v	41.90	6.91	32.83	68.45	74.00	-5.55	Peak
10.96	51.37	118.00	118.00	h	41.90	6.91	32.83	67.35	74.00	-6.65	Peak
10.96	30.56	54.00	115.00	v	41.90	6.91	32.83	46.54	54.00	-7.46	Ave
10.96	29.46	118.00	118.00	h	41.90	6.91	32.83	45.44	54.00	-8.56	Ave

Emission was scanned up to 40GHz

Mid Channel (16MHz Mode 2)

Frequency	Reading	Direction	Height	Polar	Antenna Loss	Cable loss	Amplifier	Corrected Reading	15.407/15.209	15.407/15.209	
GHz	(dBuV/m)	Degree	Meter	H / V	(dB)	(dB)	(dB)	(dBuV/m)	Limit (dBuV/m)	Margin	Comments
11.19	52.62	117.00	210.00	v	41.70	7.17	32.70	68.79	74.00	-5.21	Peak
11.19	51.63	119.00	145.00	h	41.70	7.17	32.70	67.80	74.00	-6.20	Peak
11.19	30.52	117.00	210.00	v	41.70	7.17	32.70	46.69	54.00	-7.31	Ave
11.19	29.46	119.00	145.00	h	41.70	7.17	32.70	45.63	54.00	-8.37	Ave

Emission was scanned up to 40GHz

High Channel (16MHz Mode 2)

Frequency	Reading	Direction	Height	Polar	Antenna Loss	Cable loss	Amplifier	Corrected Reading	15.407/15.209	15.407/15.209	
GHz	(dBuV/m)	Degree	Meter	H / V	(dB)	(dB)	(dB)	(dBuV/m)	Limit (dBuV/m)	Margin	Comments
11.43	52.57	310.00	234.00	v	41.70	7.17	32.70	68.74	74.00	-5.26	Peak
11.43	51.47	123.00	134.00	h	41.70	7.17	32.70	67.64	74.00	-6.36	Peak
11.43	30.53	310.00	234.00	v	41.70	7.17	32.70	46.70	54.00	-7.30	Ave
11.43	29.57	123.00	134.00	h	41.70	7.17	32.70	45.74	54.00	-8.26	Ave

Emission was scanned up to 40GHz

Low Channel (16MHz Mode 3)

Frequency	Reading	Direction	Height	Polar	Antenna Loss	Cable loss	Amplifier	Corrected Reading	15.407/15.209	15.407/15.209	
GHz	(dBuV/m)	Degree	Meter	H / V	(dB)	(dB)	(dB)	(dBuV/m)	Limit (dBuV/m)	Margin	Comments
10.96	52.52	145.00	116.00	v	41.90	6.91	32.83	68.50	74.00	-5.50	Peak
10.96	51.63	134.00	119.00	h	41.90	6.91	32.83	67.61	74.00	-6.39	Peak
10.96	30.57	145.00	116.00	v	41.90	6.91	32.83	46.55	54.00	-7.45	Ave
10.96	29.63	134.00	119.00	h	41.90	6.91	32.83	45.61	54.00	-8.39	Ave

Emission was scanned up to 40GHz

Mid Channel (16MHz Mode 3)

Frequency	Reading	Direction	Height	Polar	Antenna Loss	Cable loss	Amplifier	Corrected Reading	15.407/15.209	15.407/15.209	
GHz	(dBuV/m)	Degree	Meter	H / V	(dB)	(dB)	(dB)	(dBuV/m)	Limit (dBuV/m)	Margin	Comments
11.19	52.63	311.00	112.00	v	41.70	7.17	32.70	68.80	74.00	-5.20	Peak
11.19	51.63	145.00	118.00	h	41.70	7.17	32.70	67.80	74.00	-6.20	Peak
11.19	29.57	311.00	112.00	v	41.70	7.17	32.70	45.74	54.00	-8.26	Ave
11.19	28.73	145.00	118.00	h	41.70	7.17	32.70	44.90	54.00	-9.10	Ave

Emission was scanned up to 40GHz

High Channel (16MHz Mode 3)

Frequency	Reading	Direction	Height	Polar	Antenna Loss	Cable loss	Amplifier	Corrected Reading	15.407/15.209	15.407/15.209	
GHz	(dBuV/m)	Degree	Meter	H / V	(dB)	(dB)	(dB)	(dBuV/m)	Limit (dBuV/m)	Margin	Comments
11.43	52.73	222.00	119.00	v	41.70	7.17	32.70	68.90	74.00	-5.10	Peak
11.43	51.73	145.00	123.00	h	41.70	7.17	32.70	67.90	74.00	-6.10	Peak
11.43	29.57	222.00	119.00	v	41.70	7.17	32.70	45.74	54.00	-8.26	Ave
11.43	28.48	145.00	123.00	h	41.70	7.17	32.70	44.65	54.00	-9.35	Ave

Emission was scanned up to 40GHz

Low Channel (32MHz Mode 1)

Frequency	Reading	Direction	Height	Polar	Antenna Loss	Cable loss	Amplifier	Corrected Reading	15.407/15.209	15.407/15.209	
GHz	(dBuV/m)	Degree	Meter	H / V	(dB)	(dB)	(dB)	(dBuV/m)	Limit (dBuV/m)	Margin	Comments
10.96	52.57	223.00	132.00	v	41.90	6.91	32.83	68.55	74.00	-5.45	Peak
10.96	51.37	118.00	112.00	h	41.90	6.91	32.83	67.35	74.00	-6.65	Peak
10.96	30.47	223.00	132.00	v	41.90	6.91	32.83	46.45	54.00	-7.55	Ave
10.96	29.14	118.00	112.00	h	41.90	6.91	32.83	45.12	54.00	-8.88	Ave

Emission was scanned up to 40GHz

Mid Channel (32MHz Mode 1)

Frequency	Reading	Direction	Height	Polar	Antenna Loss	Cable loss	Amplifier	Corrected Reading	15.407/15.209	15.407/15.209	
GHz	(dBuV/m)	Degree	Meter	H / V	(dB)	(dB)	(dB)	(dBuV/m)	Limit (dBuV/m)	Margin	Comments
11.19	52.46	321.00	165.00	v	41.70	7.17	32.70	68.63	74.00	-5.37	Peak
11.19	51.38	123.00	187.00	h	41.70	7.17	32.70	67.55	74.00	-6.45	Peak
11.19	29.49	321.00	165.00	v	41.70	7.17	32.70	45.66	54.00	-8.34	Ave
11.19	29.16	123.00	187.00	h	41.70	7.17	32.70	45.33	54.00	-8.67	Ave

Emission was scanned up to 40GHz

High Channel (32MHz Mode 1)

Frequency	Reading	Direction	Height	Polar	Antenna Loss	Cable loss	Amplifier	Corrected Reading	15.407/15.209	15.407/15.209	
GHz	(dBuV/m)	Degree	Meter	H / V	(dB)	(dB)	(dB)	(dBuV/m)	Limit (dBuV/m)	Margin	Comments
11.43	52.10	287.00	114.00	v	41.70	7.17	32.70	68.27	74.00	-5.73	Peak
11.43	51.93	167.00	119.00	h	41.70	7.17	32.70	68.10	74.00	-5.90	Peak
11.43	29.62	287.00	114.00	v	41.70	7.17	32.70	45.79	54.00	-8.21	Ave
11.43	29.28	167.00	119.00	h	41.70	7.17	32.70	45.45	54.00	-8.55	Ave

Emission was scanned up to 40GHz

Low Channel (32MHz Mode 2)

Frequency	Reading	Direction	Height	Polar	Antenna Loss	Cable loss	Amplifier	Corrected Reading	15.407/15.209	15.407/15.209	
GHz	(dBuV/m)	Degree	Meter	H / V	(dB)	(dB)	(dB)	(dBuV/m)	Limit (dBuV/m)	Margin	Comments
10.96	51.62	167.00	118.00	v	41.90	6.91	32.83	67.60	74.00	-6.40	Peak
10.96	51.29	156.00	114.00	h	41.90	6.91	32.83	67.27	74.00	-6.73	Peak
10.96	29.58	167.00	118.00	v	41.90	6.91	32.83	45.56	54.00	-8.44	Ave
10.96	29.37	156.00	114.00	h	41.90	6.91	32.83	45.35	54.00	-8.65	Ave

Emission was scanned up to 40GHz

Mid Channel (32MHz Mode 2)

Frequency	Reading	Direction	Height	Polar	Antenna Loss	Cable loss	Amplifier	Corrected Reading	15.407/15.209	15.407/15.209	
GHz	(dBuV/m)	Degree	Meter	H / V	(dB)	(dB)	(dB)	(dBuV/m)	Limit (dBuV/m)	Margin	Comments
11.19	51.87	324.00	118.00	v	41.70	7.17	32.70	68.04	74.00	-5.96	Peak
11.19	51.27	147.00	112.00	h	41.70	7.17	32.70	67.44	74.00	-6.56	Peak
11.19	29.46	324.00	118.00	v	41.70	7.17	32.70	45.63	54.00	-8.37	Ave
11.19	29.12	147.00	112.00	h	41.70	7.17	32.70	45.29	54.00	-8.71	Ave

Emission was scanned up to 40GHz

High Channel (32MHz Mode 2)

Frequency	Reading	Direction	Height	Polar	Antenna Loss	Cable loss	Amplifier	Corrected Reading	15.407/15.209	15.407/15.209	
GHz	(dBuV/m)	Degree	Meter	H / V	(dB)	(dB)	(dB)	(dBuV/m)	Limit (dBuV/m)	Margin	Comments
11.43	52.82	178.00	115.00	v	41.70	7.17	32.70	68.99	74.00	-5.01	Peak
11.43	51.47	114.00	118.00	h	41.70	7.17	32.70	67.64	74.00	-6.36	Peak
11.43	30.41	178.00	115.00	v	41.70	7.17	32.70	46.58	54.00	-7.42	Ave
11.43	29.37	114.00	118.00	h	41.70	7.17	32.70	45.54	54.00	-8.46	Ave

Emission was scanned up to 40GHz

Low Channel (32MHz Mode 3)

Frequency	Reading	Direction	Height	Polar	Antenna Loss	Cable loss	Amplifier	Corrected Reading	15.407/15.209	15.407/15.209	
GHz	(dBuV/m)	Degree	Meter	H / V	(dB)	(dB)	(dB)	(dBuV/m)	Limit (dBuV/m)	Margin	Comments
10.96	51.71	167.00	112.00	v	41.90	6.91	32.83	67.69	74.00	-6.31	Peak
10.96	51.35	218.00	127.00	h	41.90	6.91	32.83	67.33	74.00	-6.67	Peak
10.96	30.41	167.00	112.00	v	41.90	6.91	32.83	46.39	54.00	-7.61	Ave
10.96	29.36	218.00	127.00	h	41.90	6.91	32.83	45.34	54.00	-8.66	Ave

Emission was scanned up to 40GHz

Mid Channel (32MHz Mode 3)

Frequency	Reading	Direction	Height	Polar	Antenna Loss	Cable loss	Amplifier	Corrected Reading	15.407/15.209	15.407/15.209	
GHz	(dBuV/m)	Degree	Meter	H / V	(dB)	(dB)	(dB)	(dBuV/m)	Limit (dBuV/m)	Margin	Comments
11.19	52.19	256.00	118.00	v	41.70	7.17	32.70	68.36	74.00	-5.64	Peak
11.19	51.73	215.00	145.00	h	41.70	7.17	32.70	67.90	74.00	-6.10	Peak
11.19	30.15	256.00	118.00	v	41.70	7.17	32.70	46.32	54.00	-7.68	Ave
11.19	29.53	215.00	145.00	h	41.70	7.17	32.70	45.70	54.00	-8.30	Ave

Emission was scanned up to 40GHz

High Channel (32MHz Mode3)

Frequency	Reading	Direction	Height	Polar	Antenna Loss	Cable loss	Amplifier	Corrected Reading	15.407/15.209	15.407/15.209	
GHz	(dBuV/m)	Degree	Meter	H / V	(dB)	(dB)	(dB)	(dBuV/m)	Limit (dBuV/m)	Margin	Comments
11.43	51.83	267.00	118.00	v	41.70	7.17	32.70	68.00	74.00	-6.00	Peak
11.43	50.62	217.00	114.00	h	41.70	7.17	32.70	66.79	74.00	-7.21	Peak
11.43	30.54	267.00	118.00	v	41.70	7.17	32.70	46.71	54.00	-7.29	Ave
11.43	29.48	217.00	114.00	h	41.70	7.17	32.70	45.65	54.00	-8.35	Ave

Emission was scanned up to 40GHz

Band edge result

5.2GHz band - Antenna type: Parabolic Dish with maximum antenna gain 37.5 dBi

Vertical Polarity

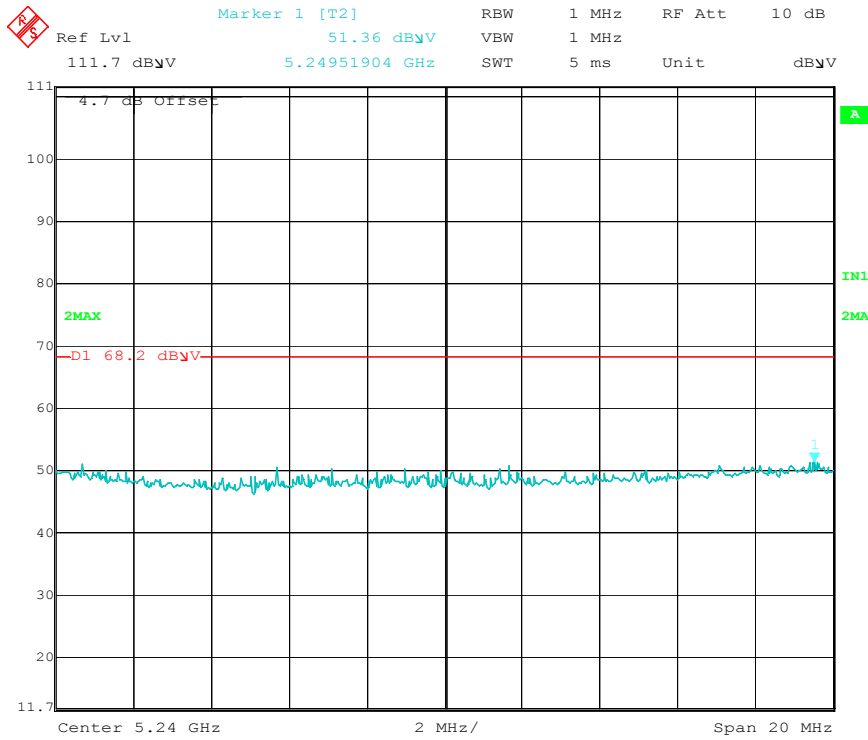

Low Channel (8MHz Mode 1)

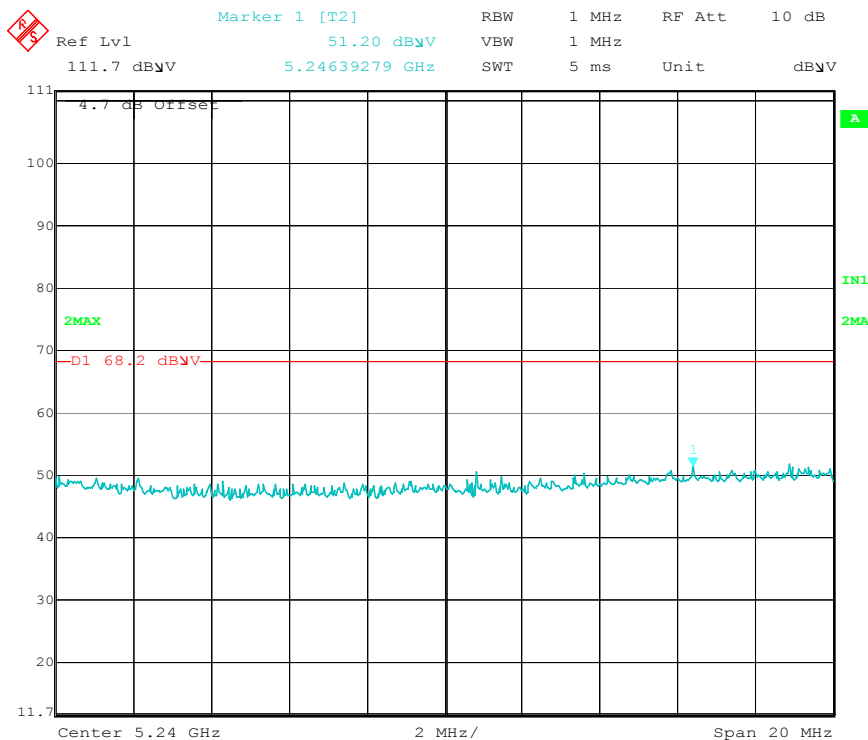

Low Channel (8MHz Mode 2)

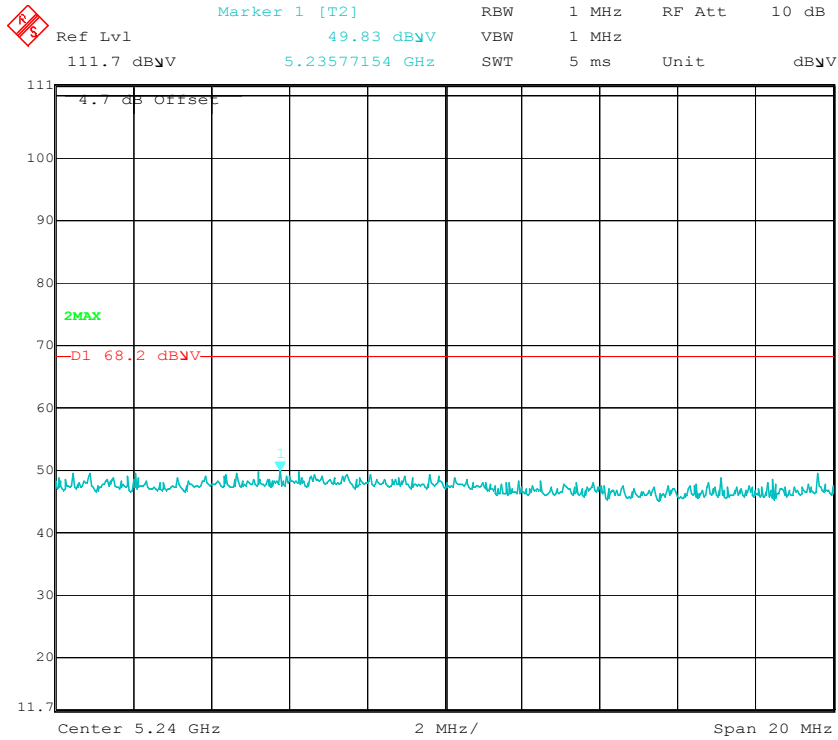

Low Channel (8MHz Mode 3)

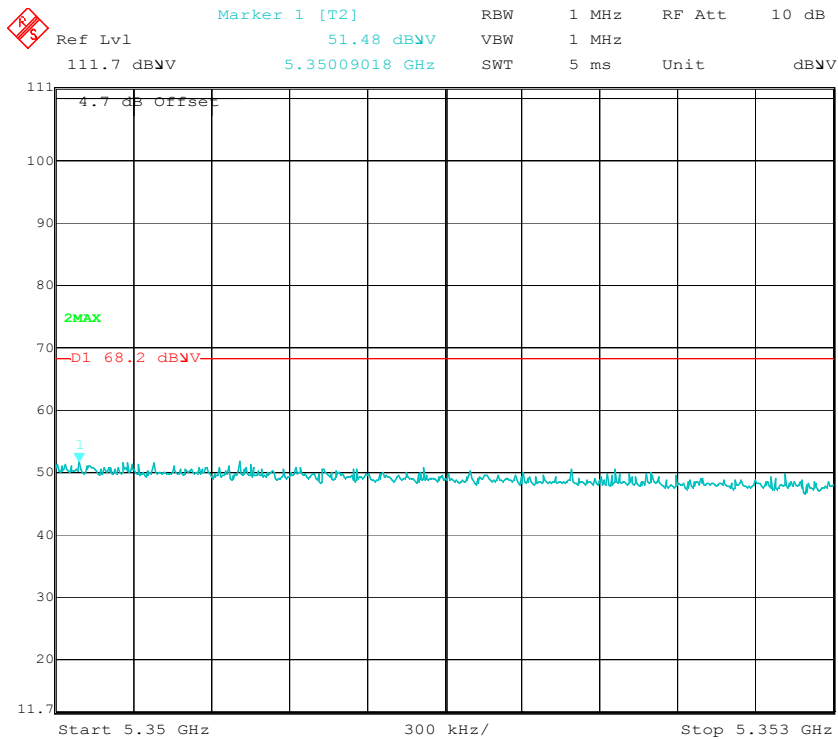

High Channel (8MHz Mode 1)

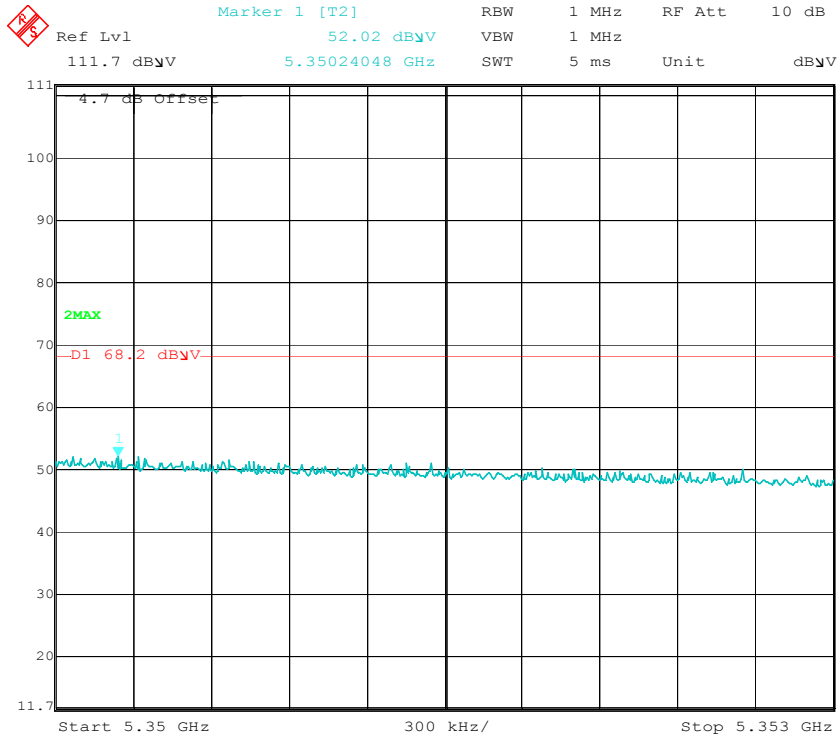

High Channel (8MHz Mode 2)

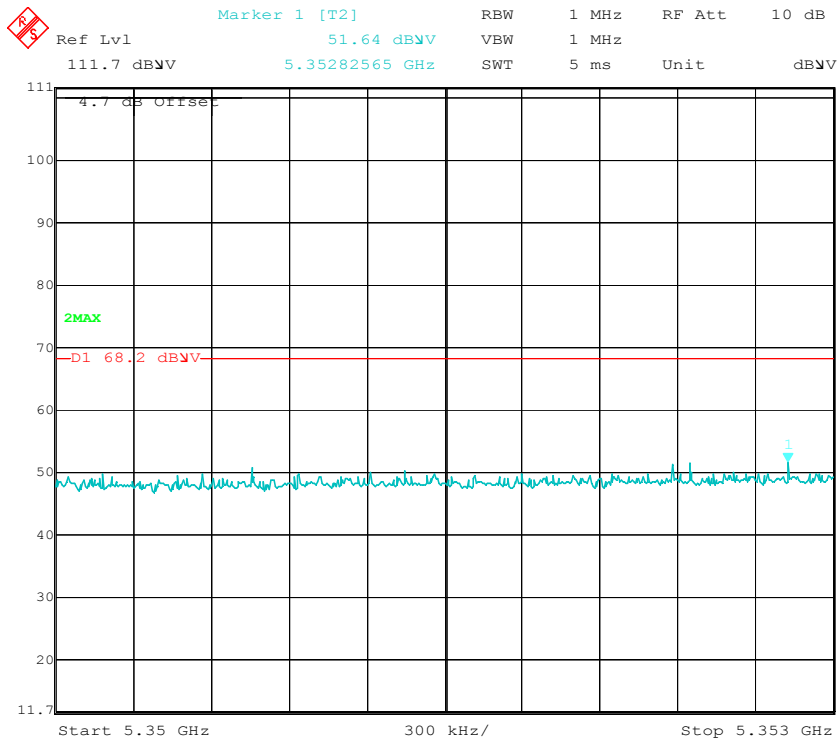

High Channel (8MHz Mode 3)

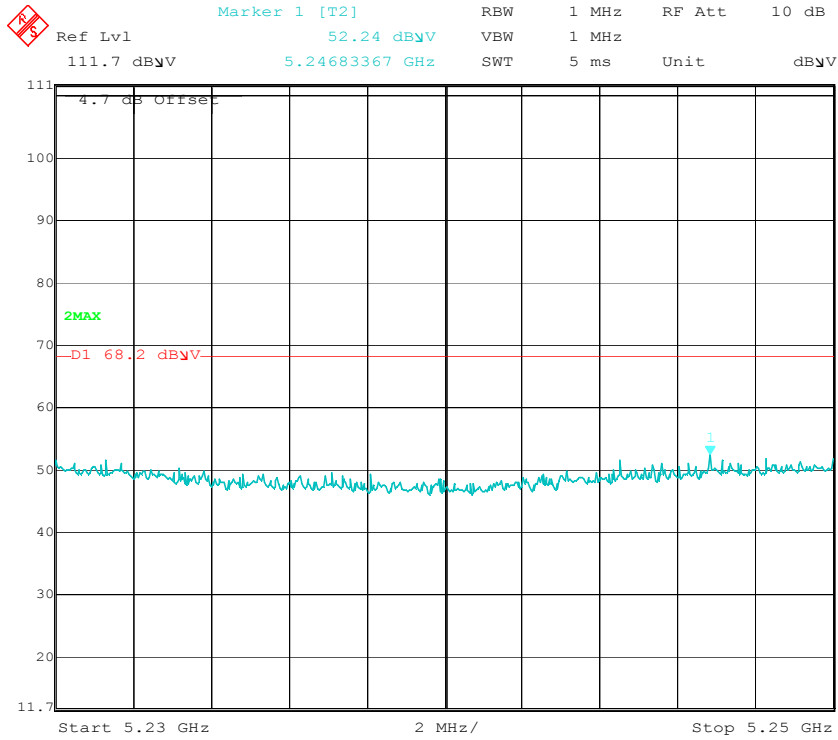

Low Channel (16MHz Mode 1)

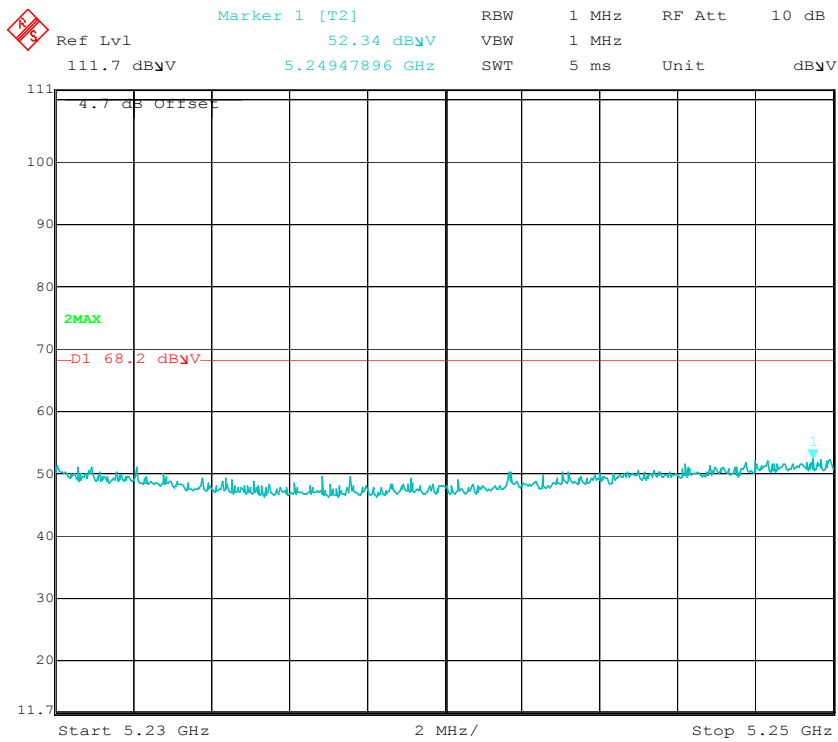

Low Channel (16MHz Mode 2)

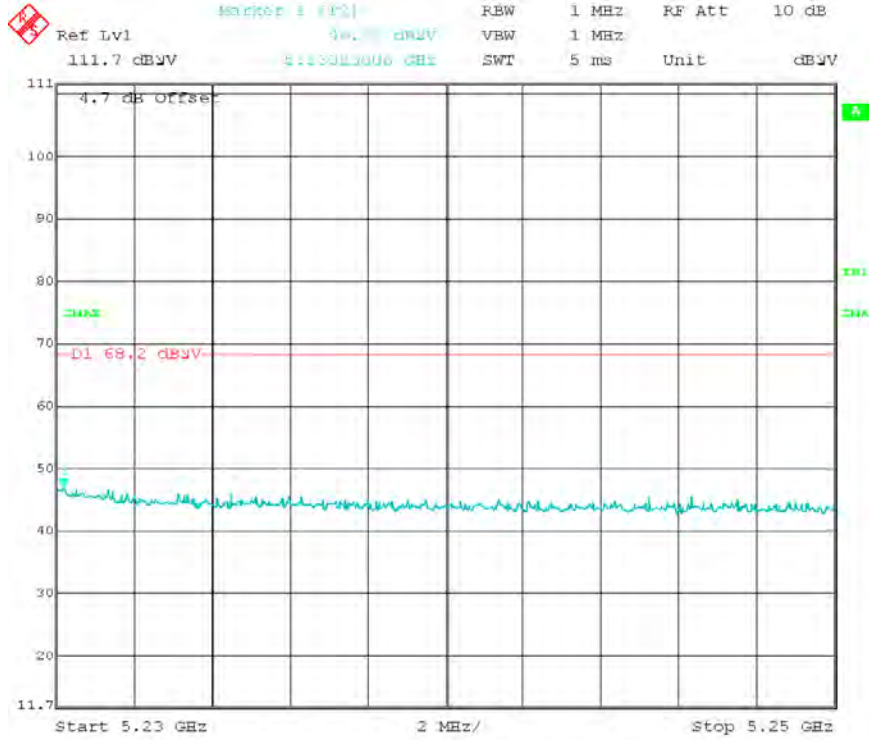

Low Channel (16MHz Mode 3)

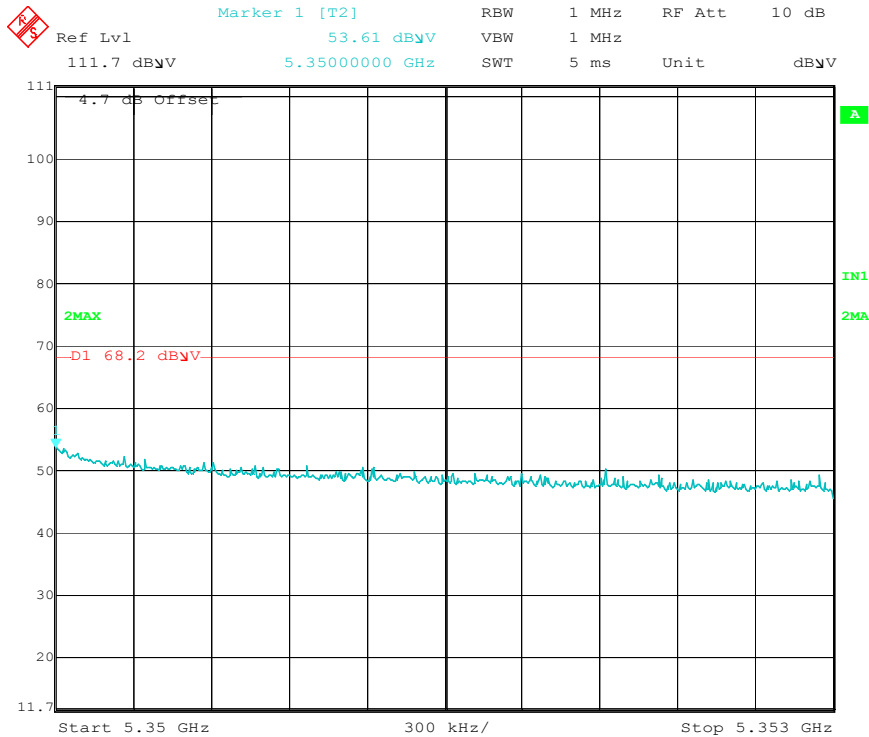

High Channel (16MHz Mode 1)

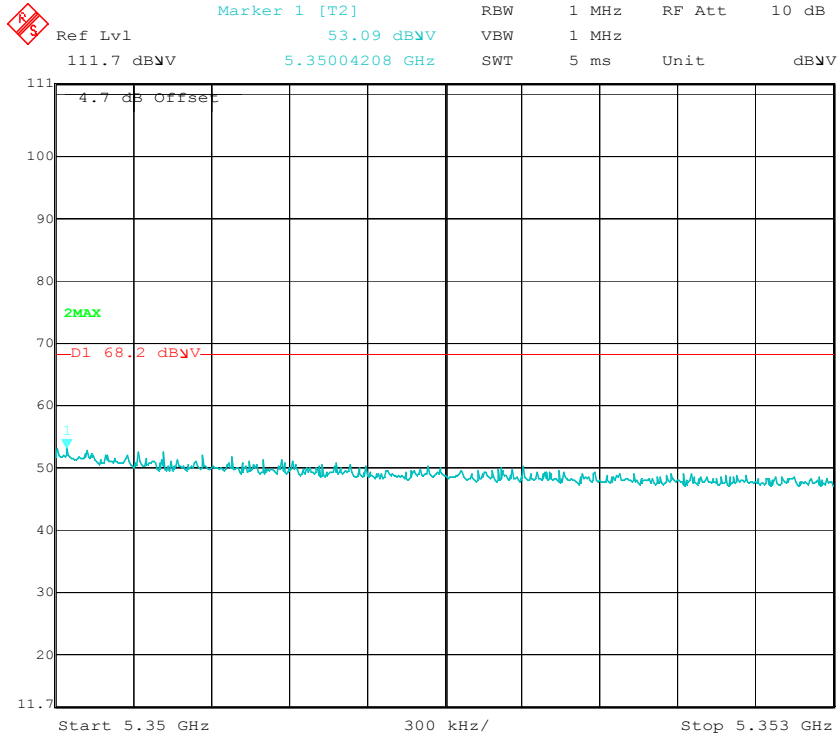

High Channel (16MHz Mode 2)

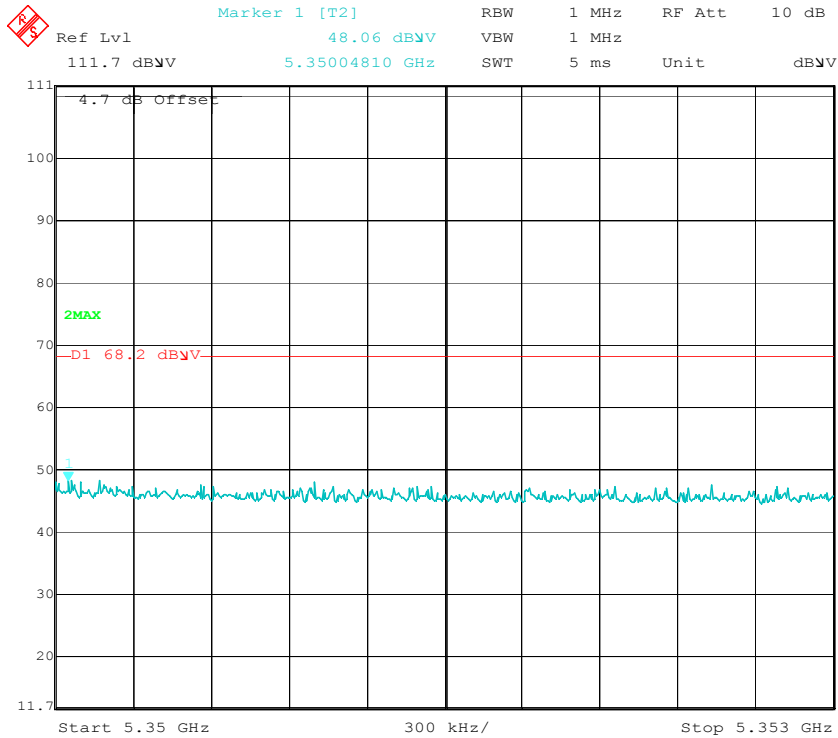

High Channel (16MHz Mode 3)



Marker 1 [T2] RBW 1 MHz RF Att 10 dB
Ref Lvl 53.00 dBV VBW 1 MHz
111.7 dBV 5.24939880 GHz SWT 5 ms Unit dBV

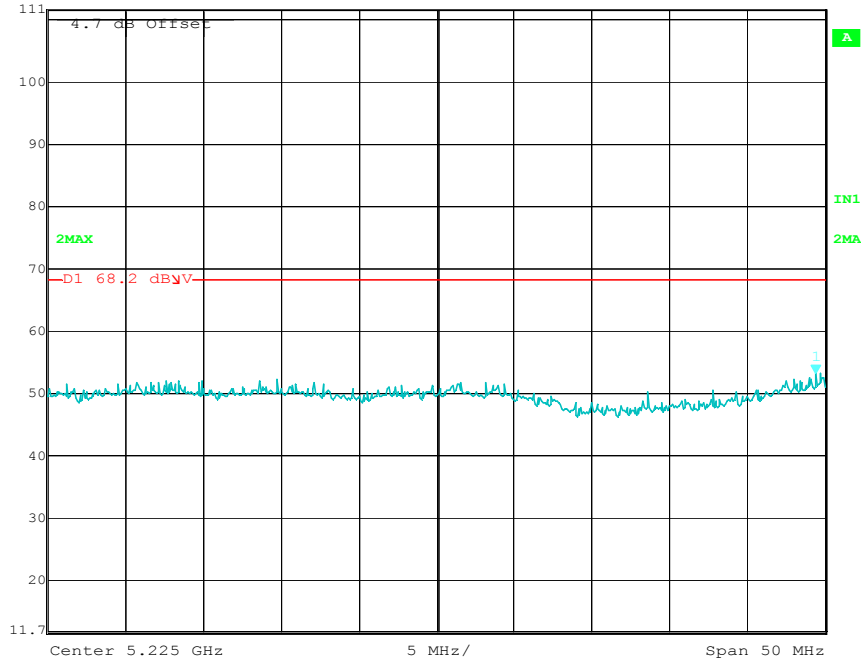

Low Channel (32MHz Mode 1)

Marker 1 [T2] RBW 1 MHz RF Att 10 dB
Ref Lvl 54.32 dBV VBW 1 MHz
111.7 dBV 5.24969940 GHz SWT 5 ms Unit dBV

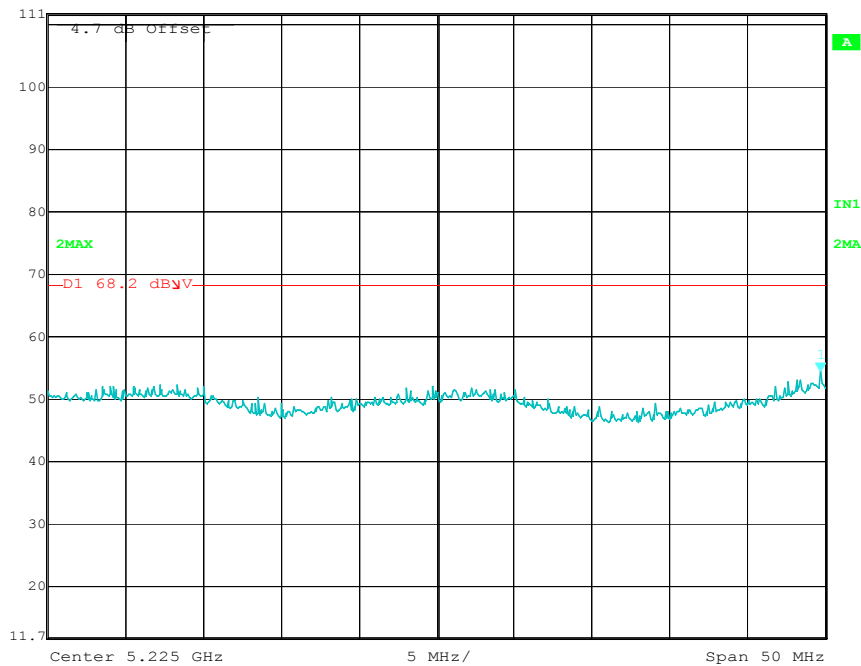

Low Channel (32MHz Mode 2)

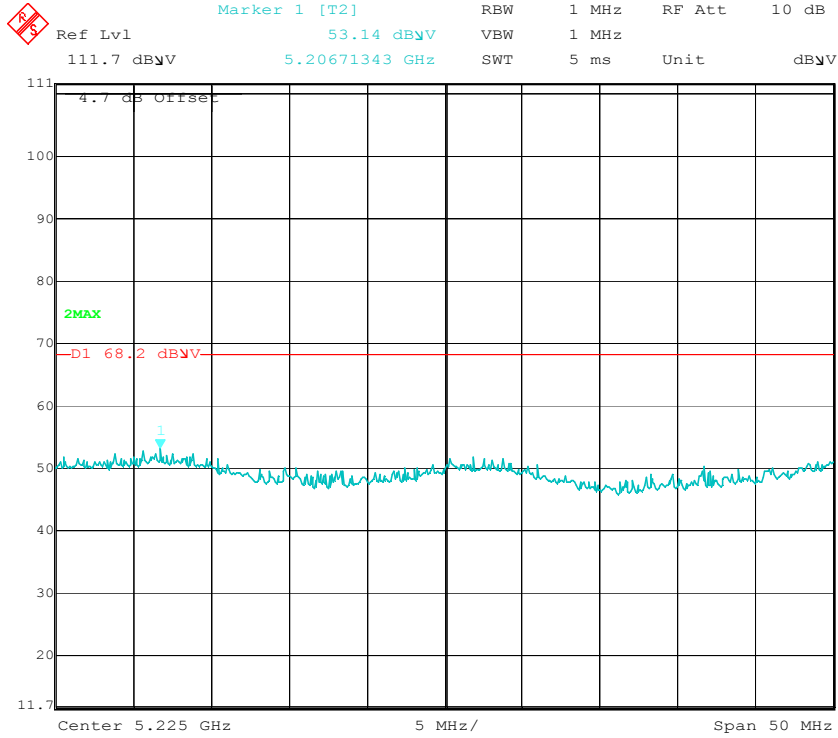

Low Channel (32MHz Mode 3)

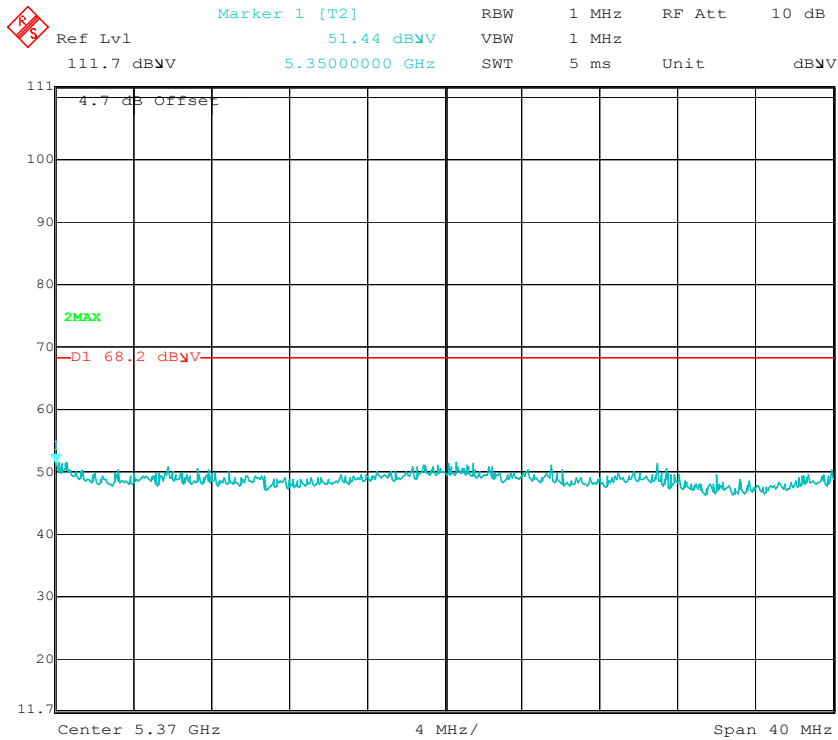

High Channel (32MHz Mode 1)

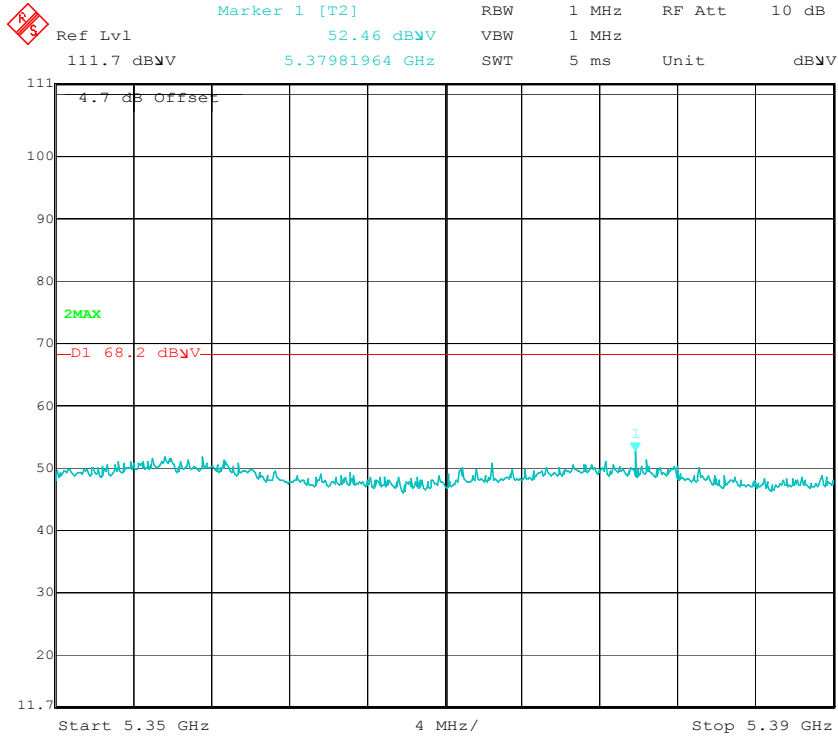

High Channel (32MHz Mode 2)

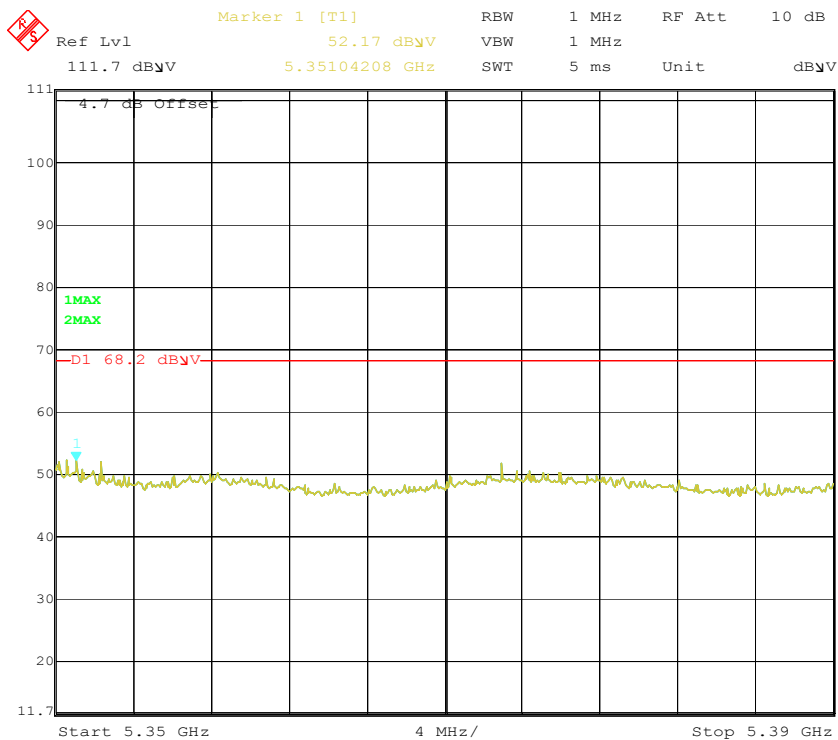

High Channel (32MHz Mode 3)

Horizontal Polarity

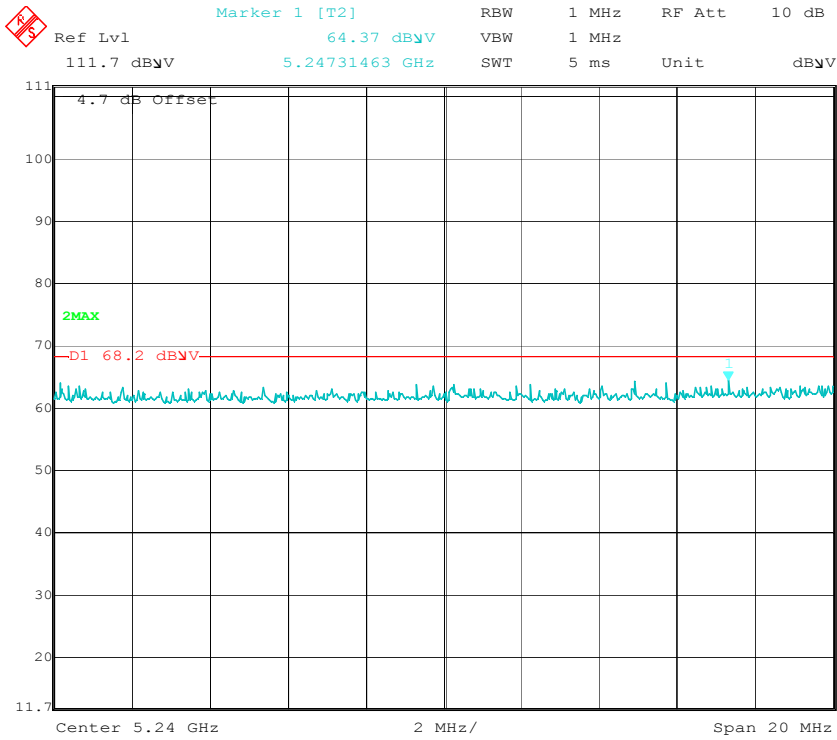

Low Channel (8MHz Mode 1)

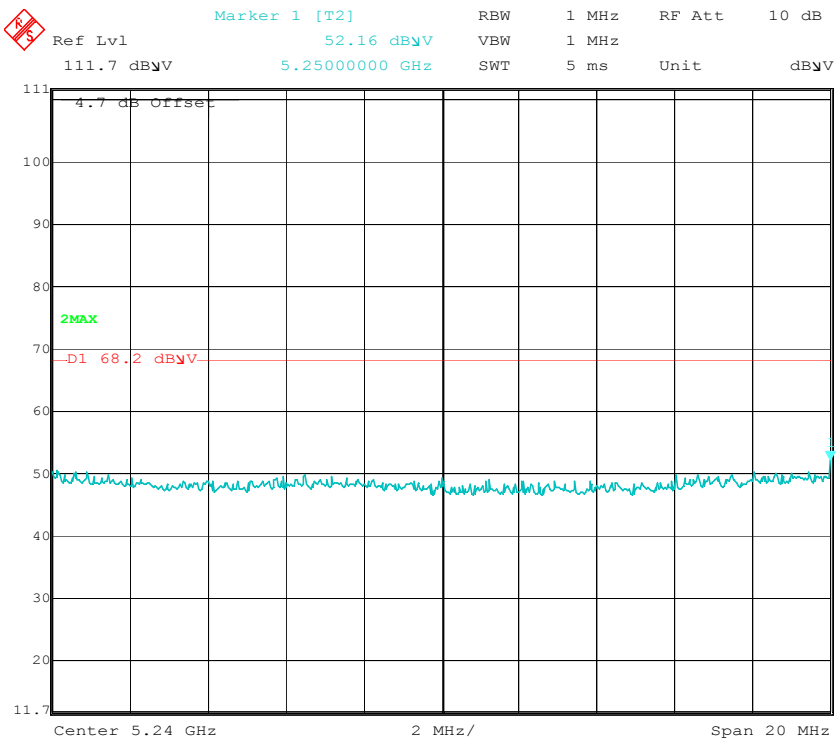

Low Channel (8MHz Mode 2)

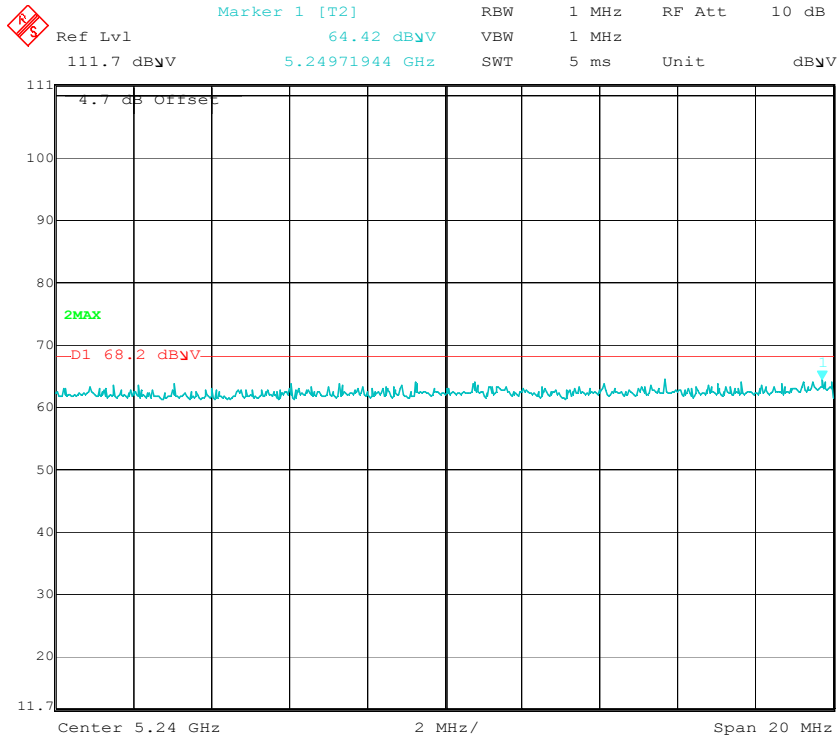

Low Channel (8MHz Mode 3)

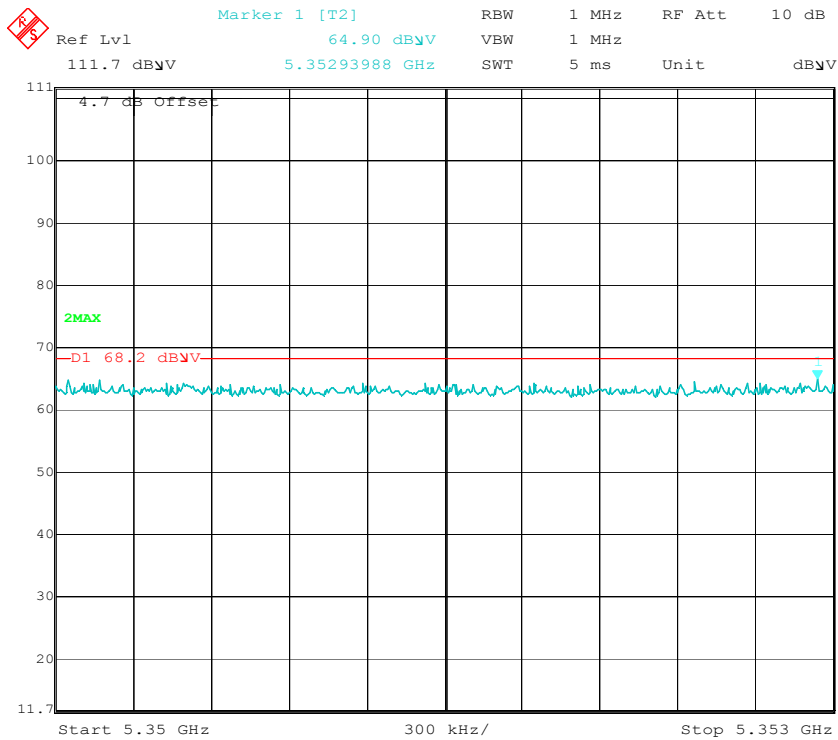

High Channel (8MHz Mode 1)

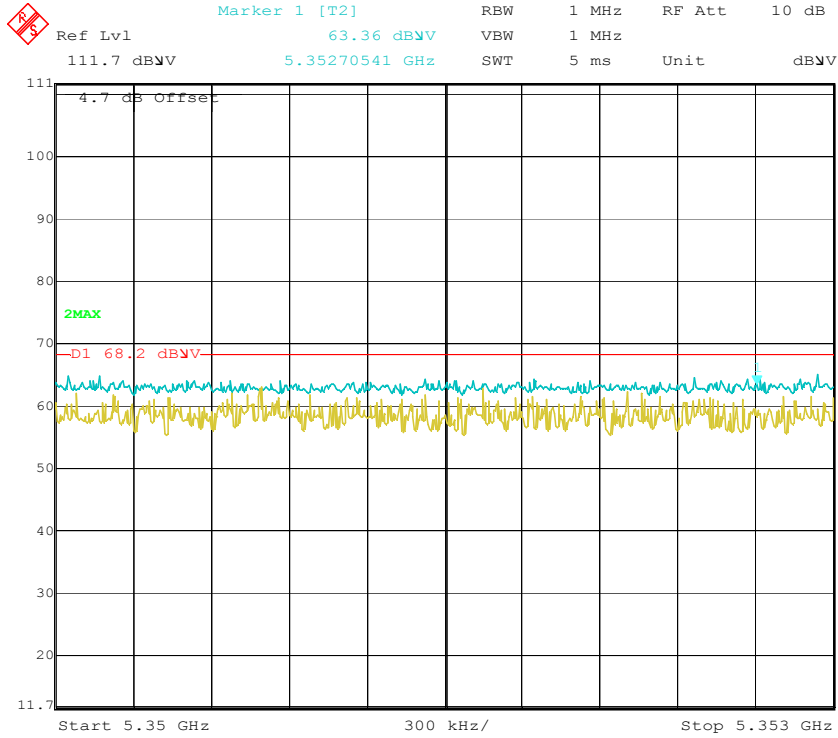

High Channel (8MHz Mode 2)

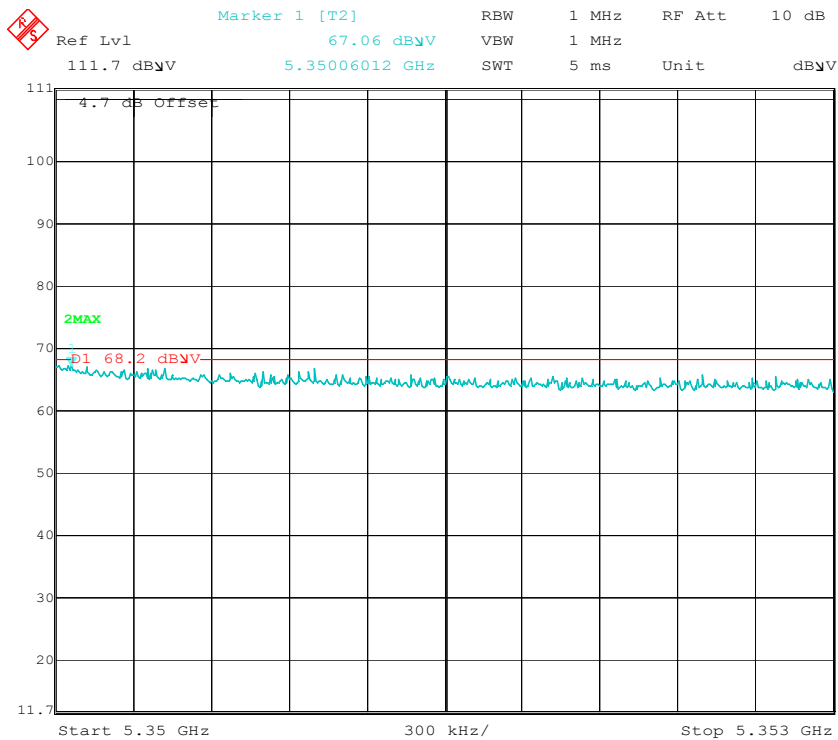

High Channel (8MHz Mode 3)

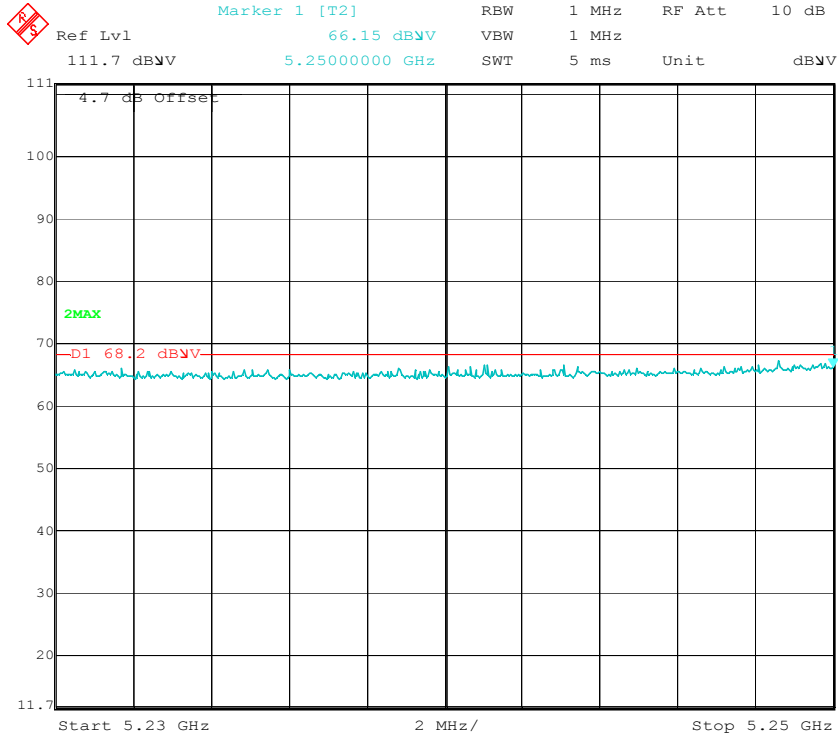

Low Channel (16MHz Mode 1)

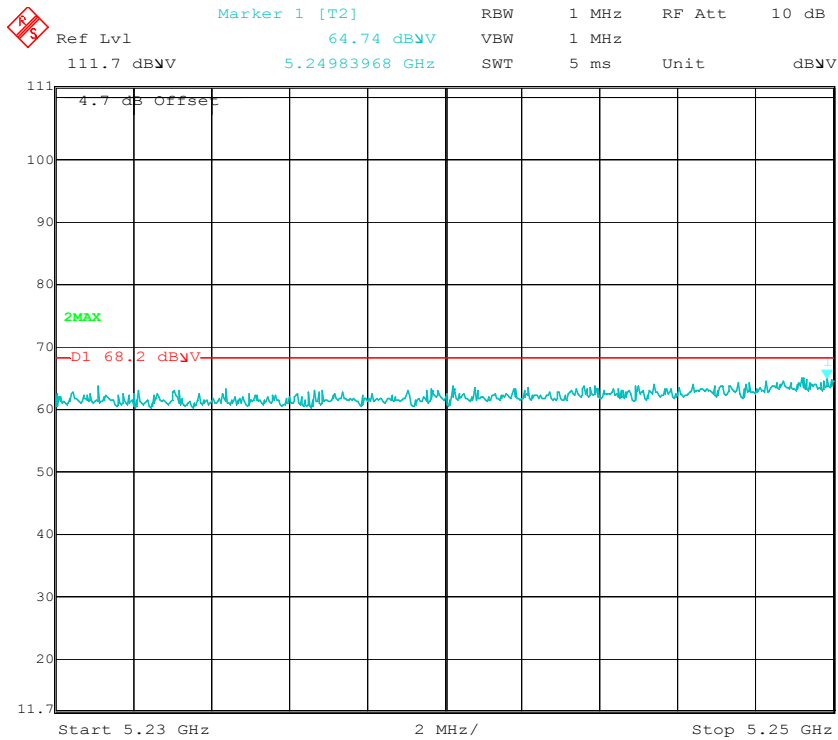

Low Channel (16MHz Mode 2)

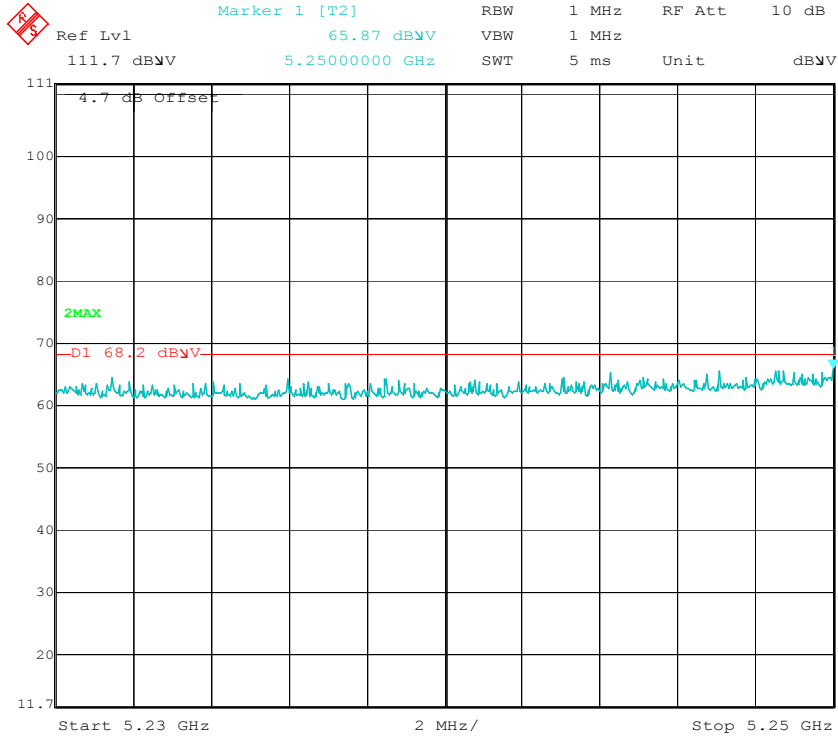

Low Channel (16MHz Mode 3)

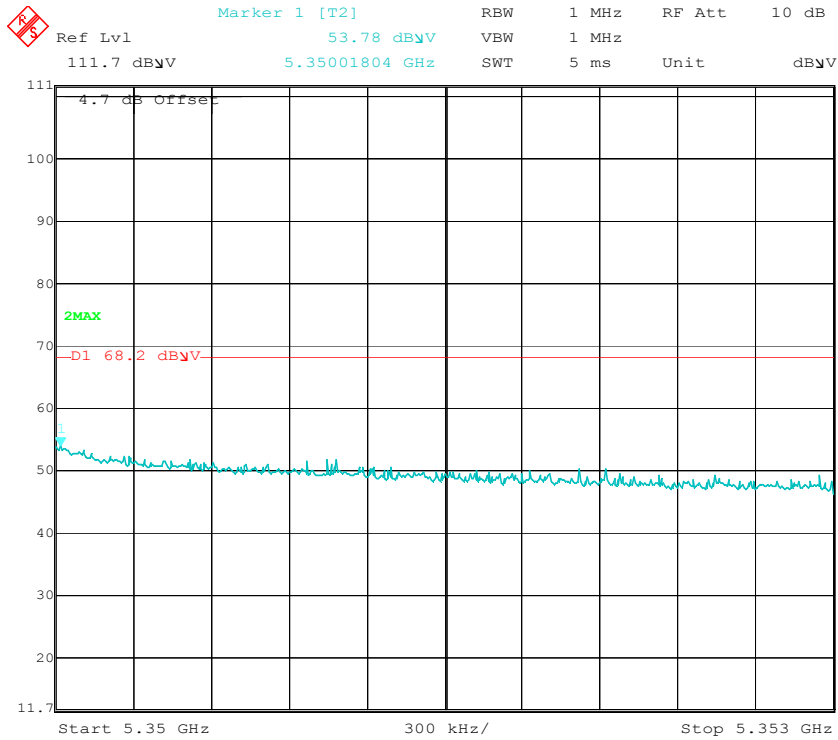

High Channel (16MHz Mode 1)

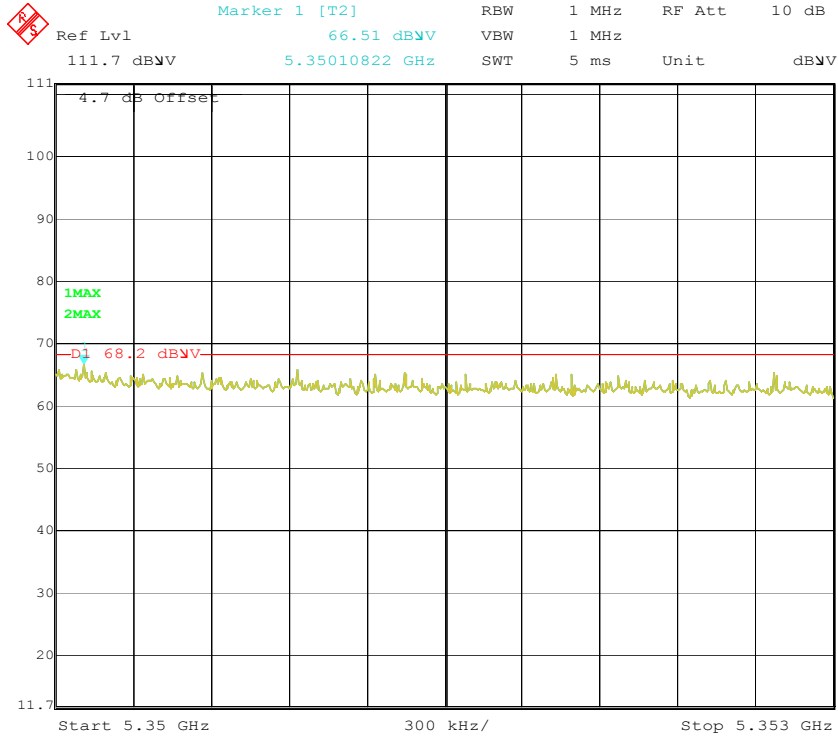

High Channel (16MHz Mode 2)

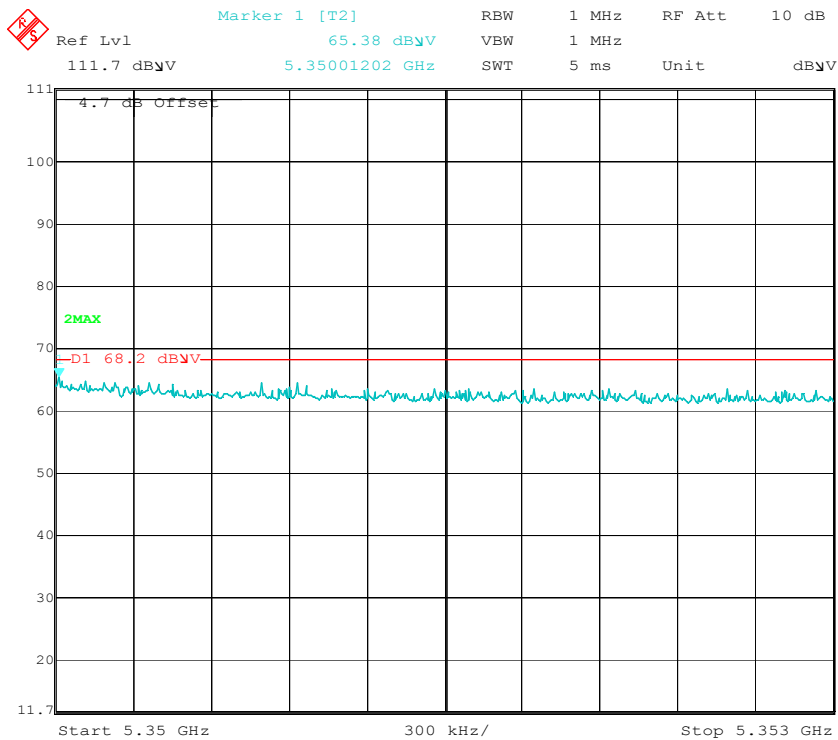

High Channel (16MHz Mode 3)

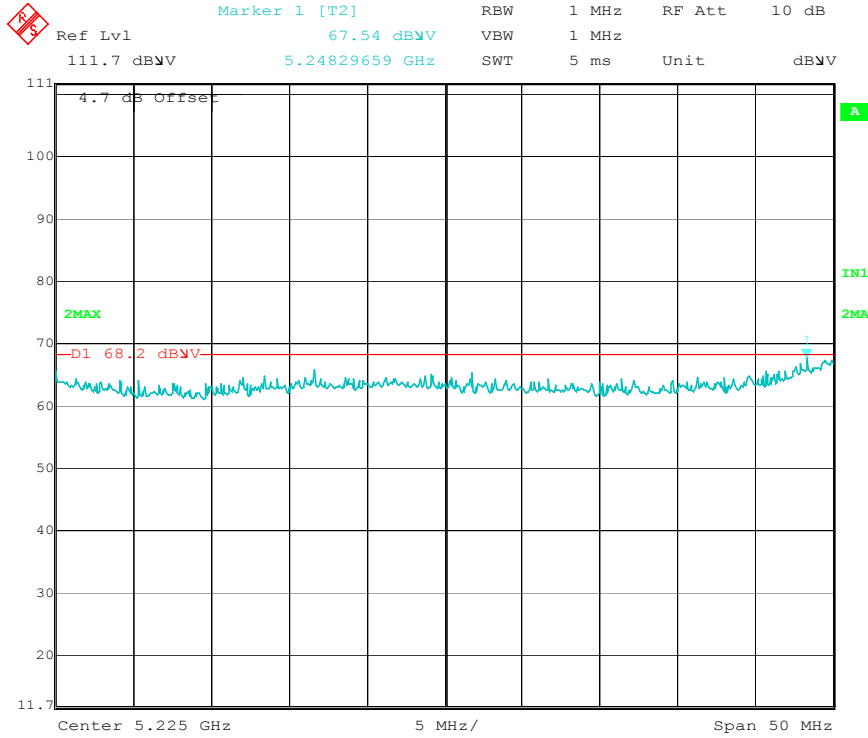

Low Channel (32MHz Mode 1)

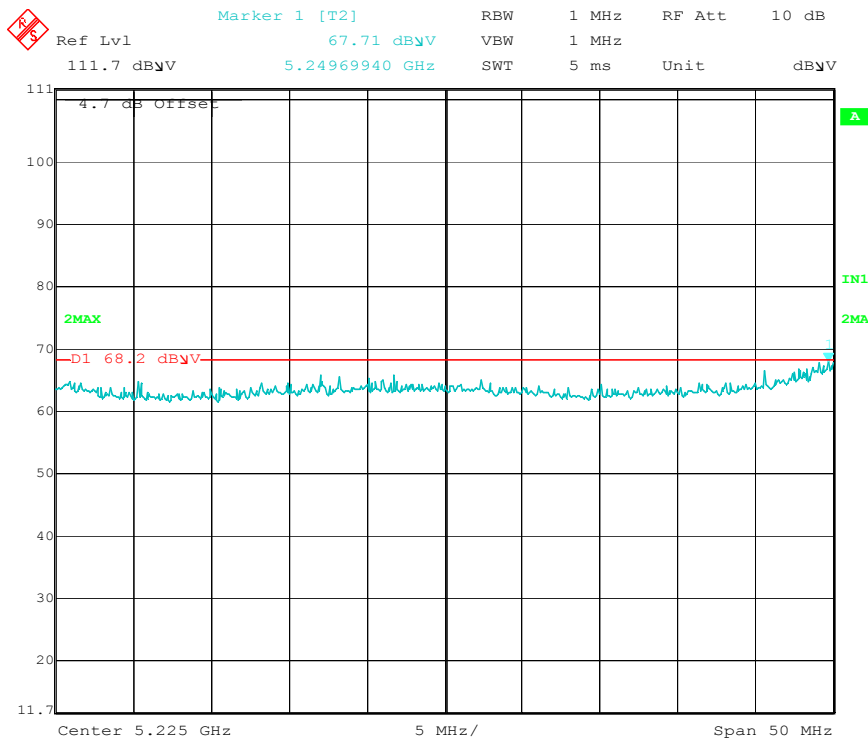

Low Channel (32MHz Mode 2)

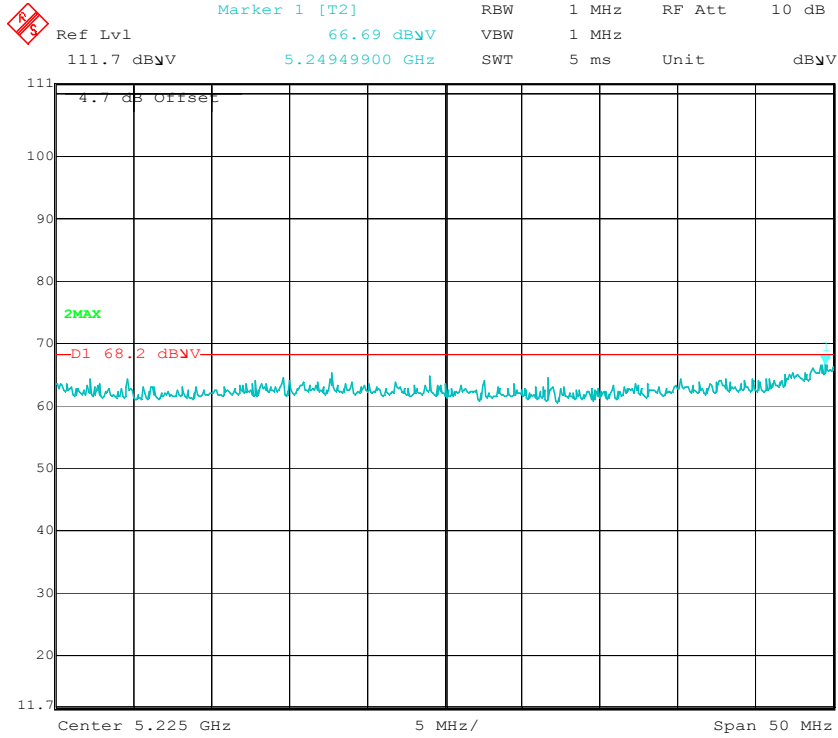

Low Channel (32MHz Mode 3)

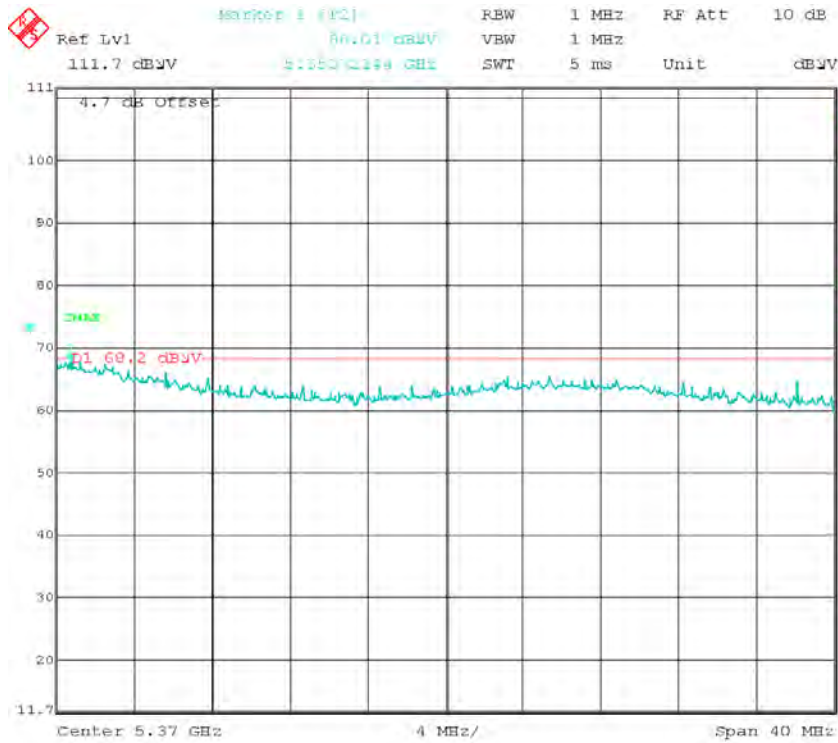

High Channel (32MHz Mode 1)

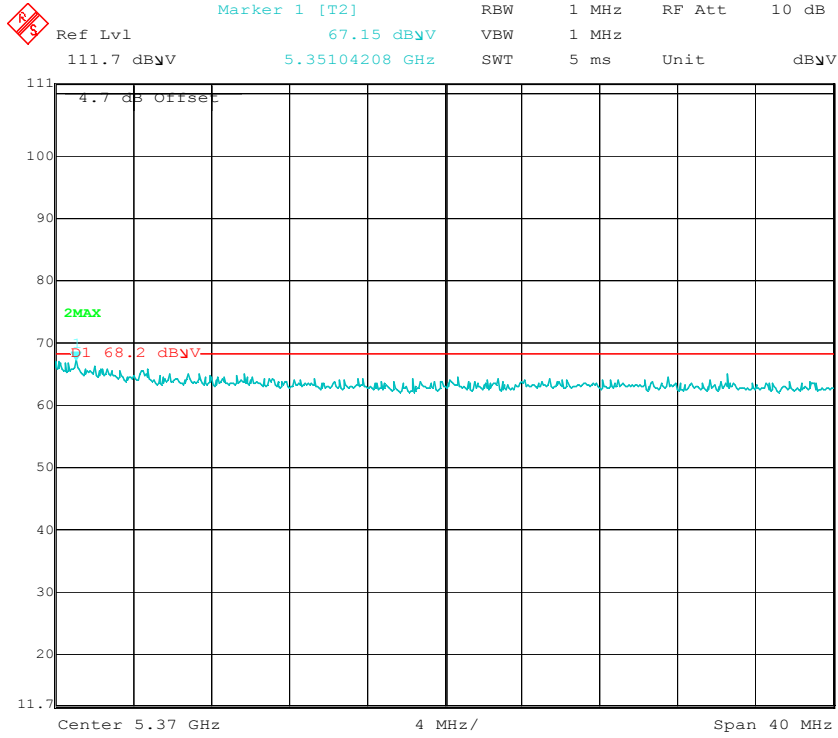

High Channel (32MHz Mode 2)

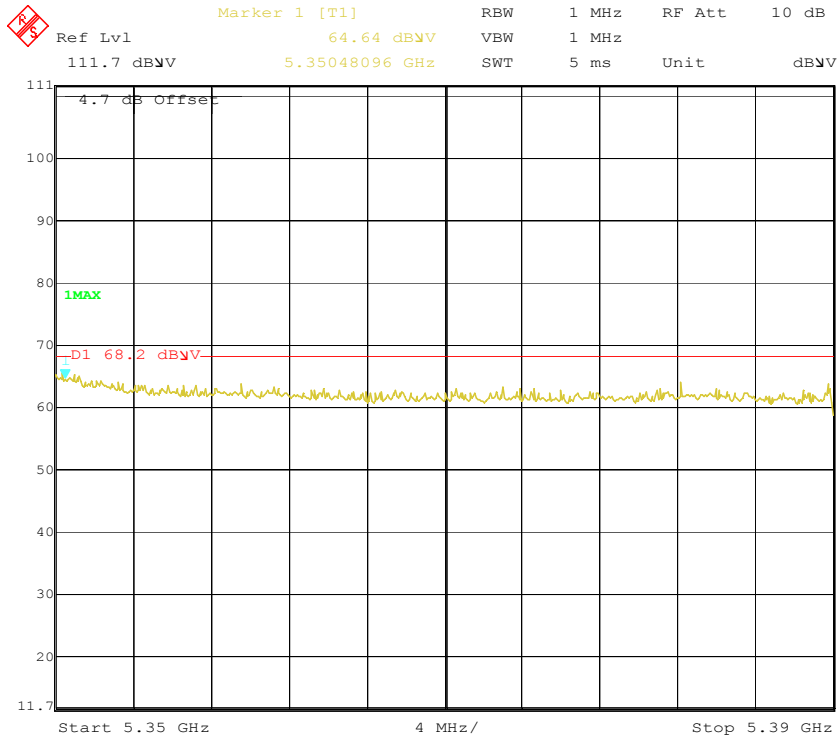

High Channel (32MHz Mode 3)

5.2GHz band- Antenna type: Panel with maximum antenna gain 28 dBi

Vertical Polarity

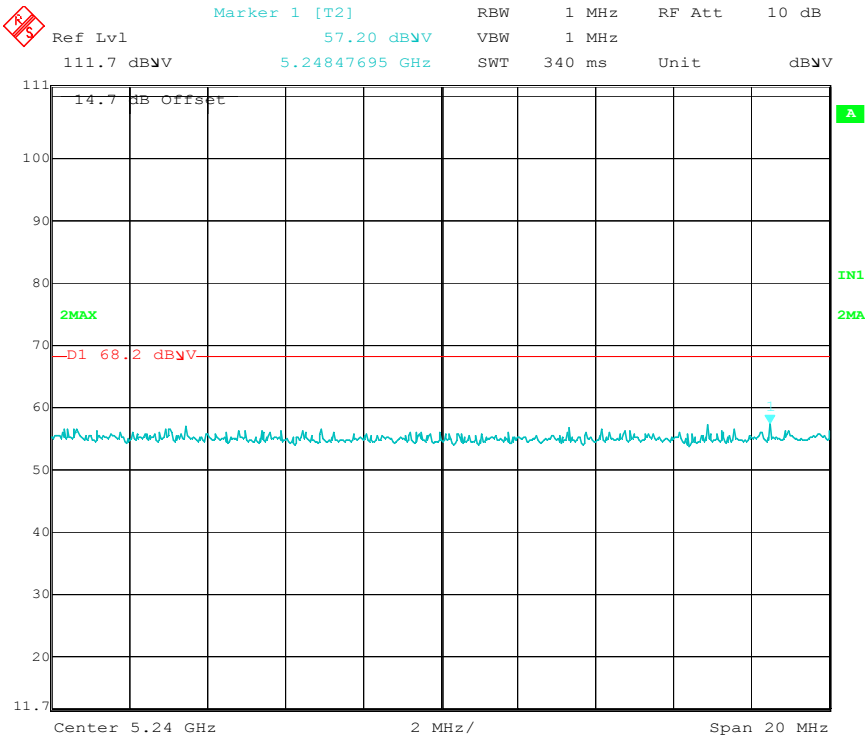

Low Channel (8MHz Mode 1)

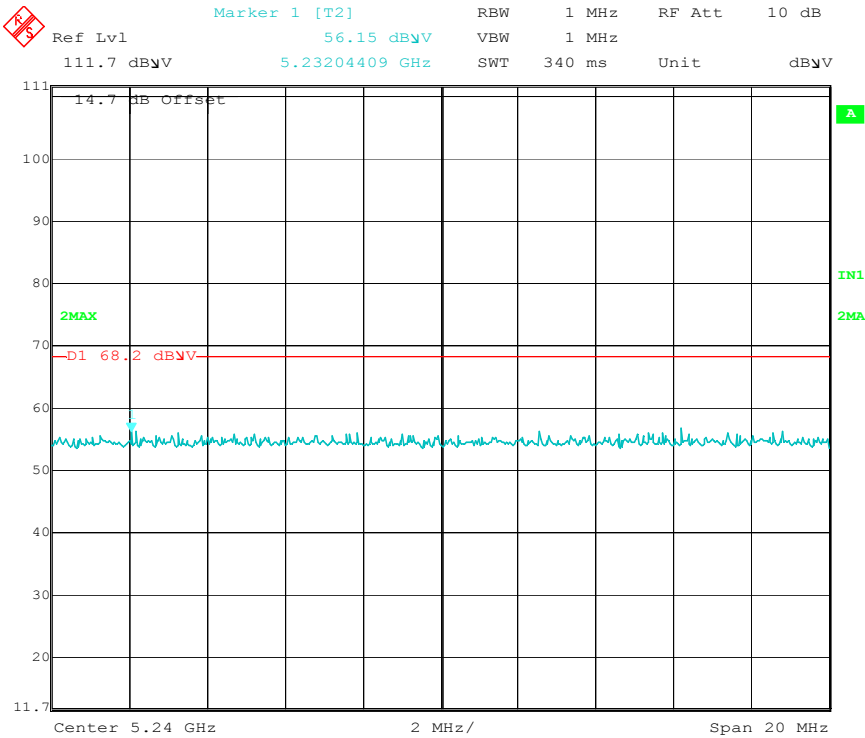

Low Channel (8MHz Mode 2)

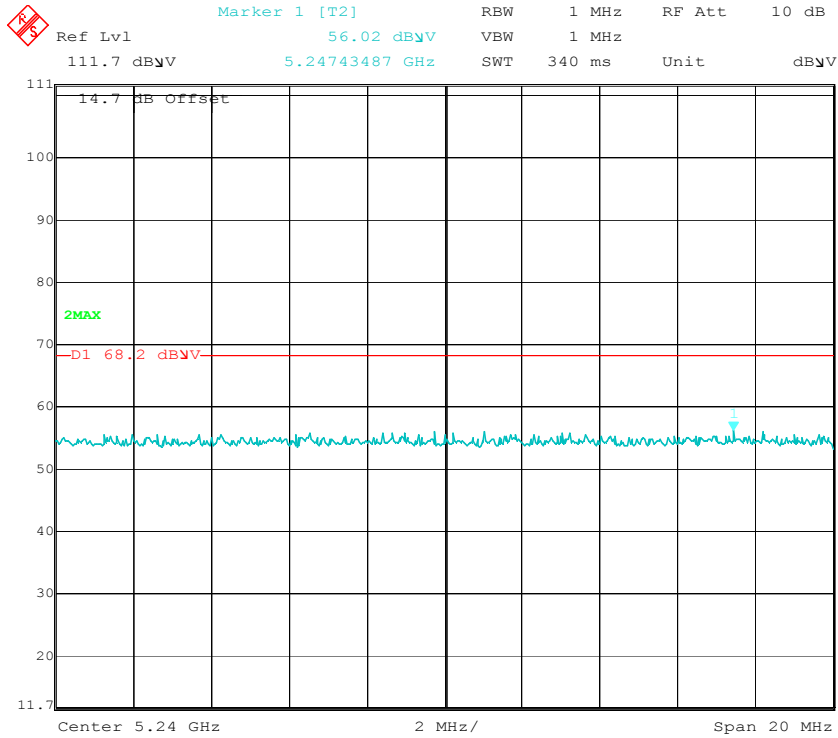

Low Channel (8MHz Mode 3)

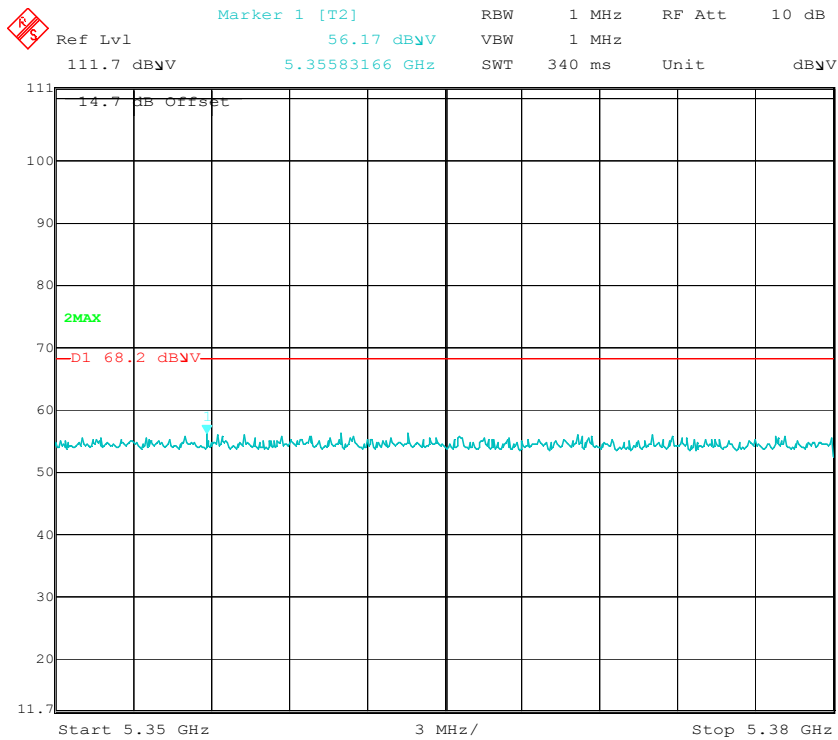

High Channel (8MHz Mode 1)

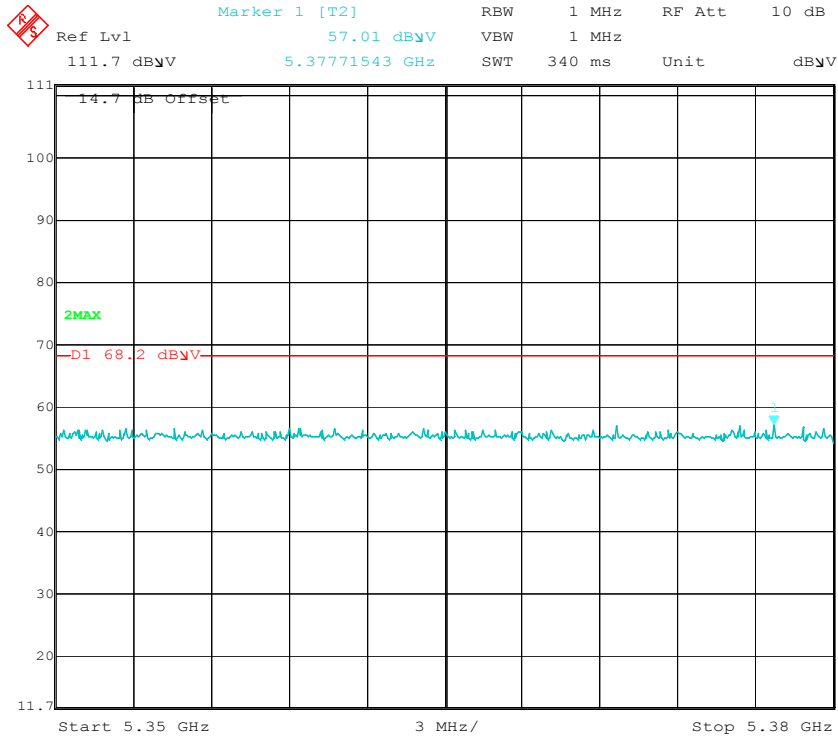

High Channel (8MHz Mode 2)

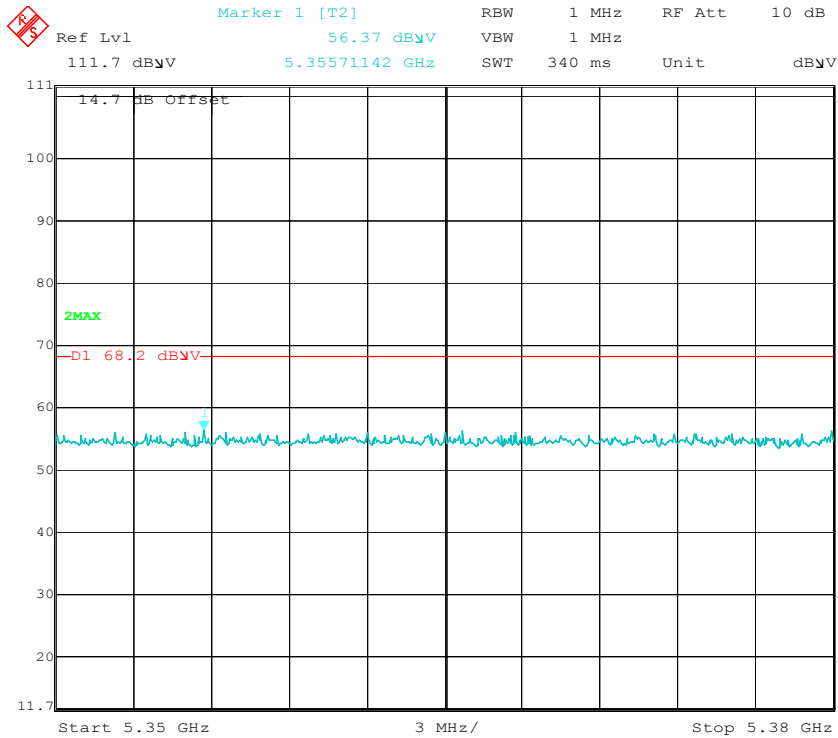

High Channel (8MHz Mode 3)

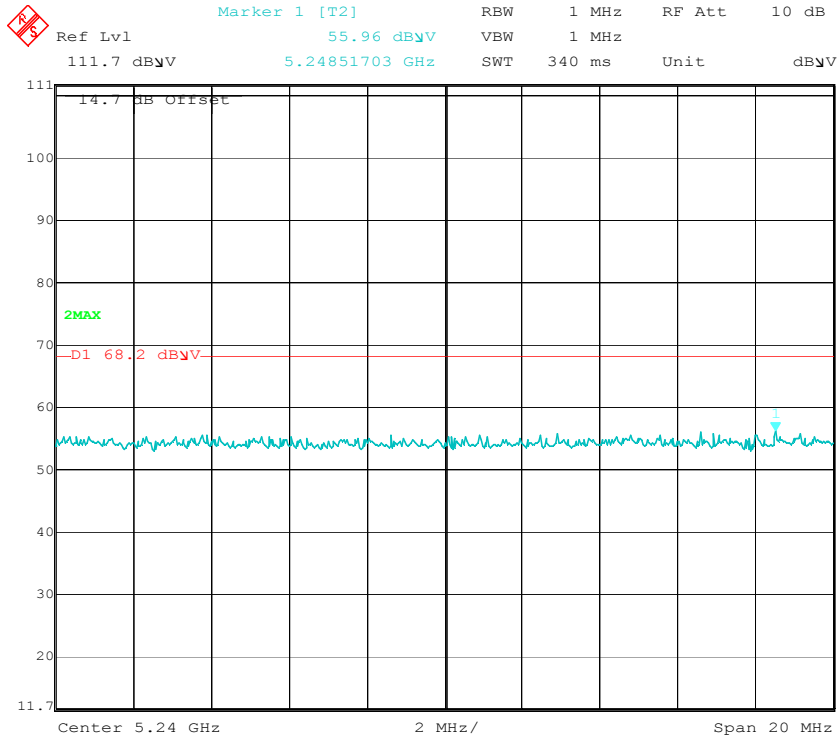

Low Channel (16MHz Mode 1)

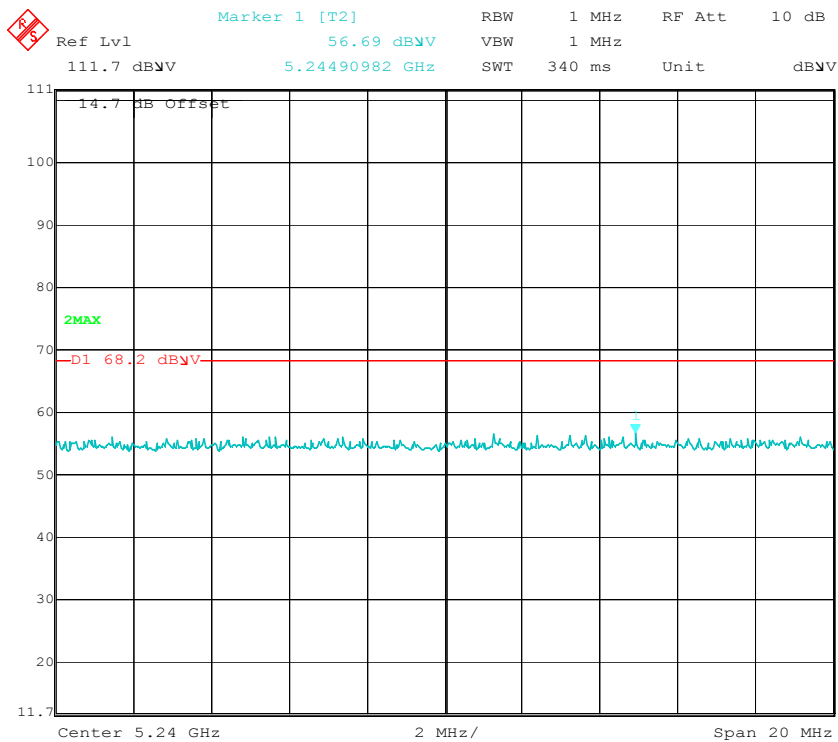

Low Channel (16MHz Mode 2)

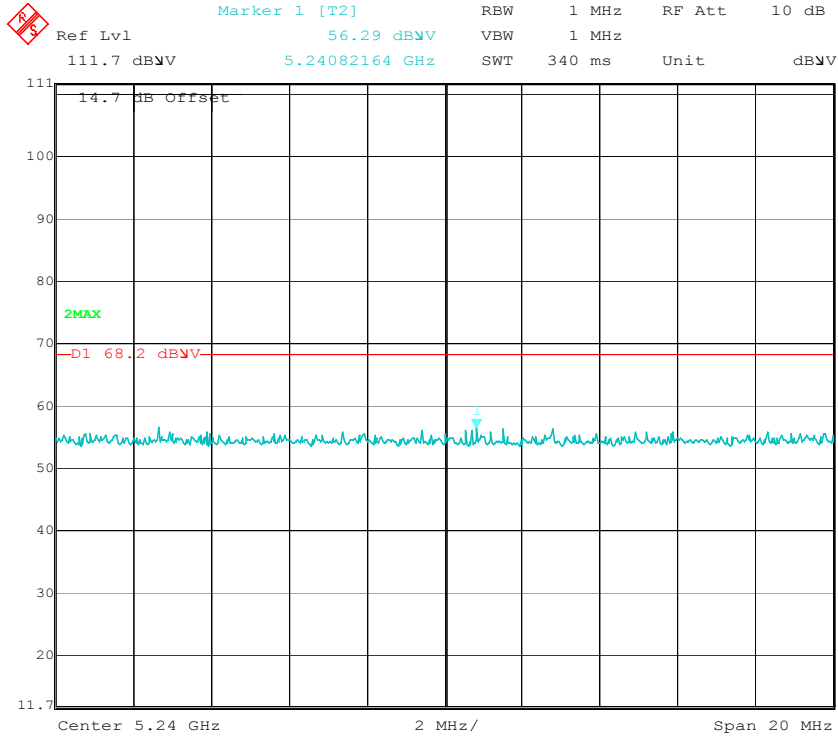

Low Channel (16MHz Mode 3)

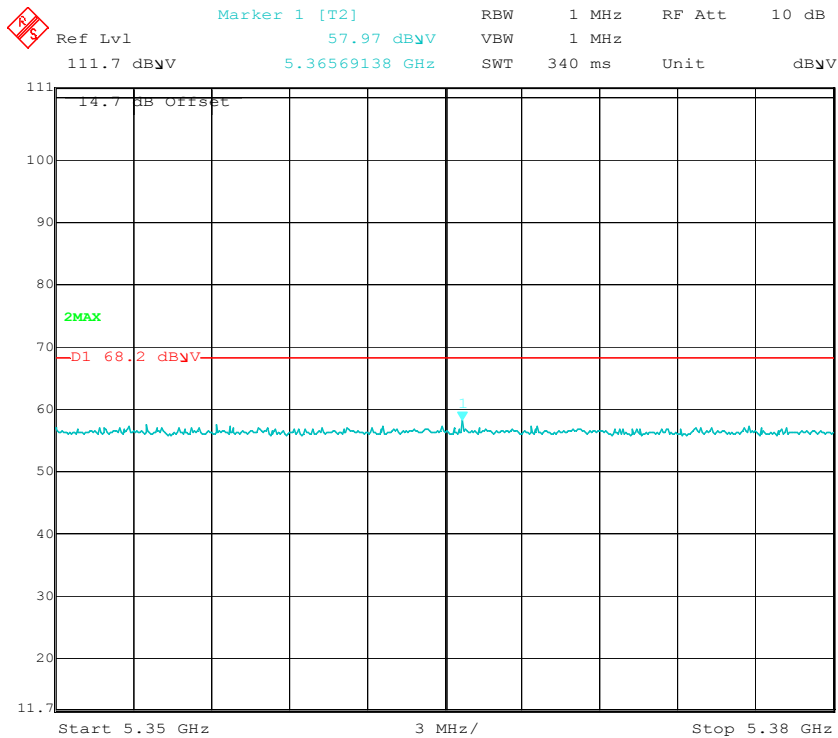

High Channel (16MHz Mode 1)

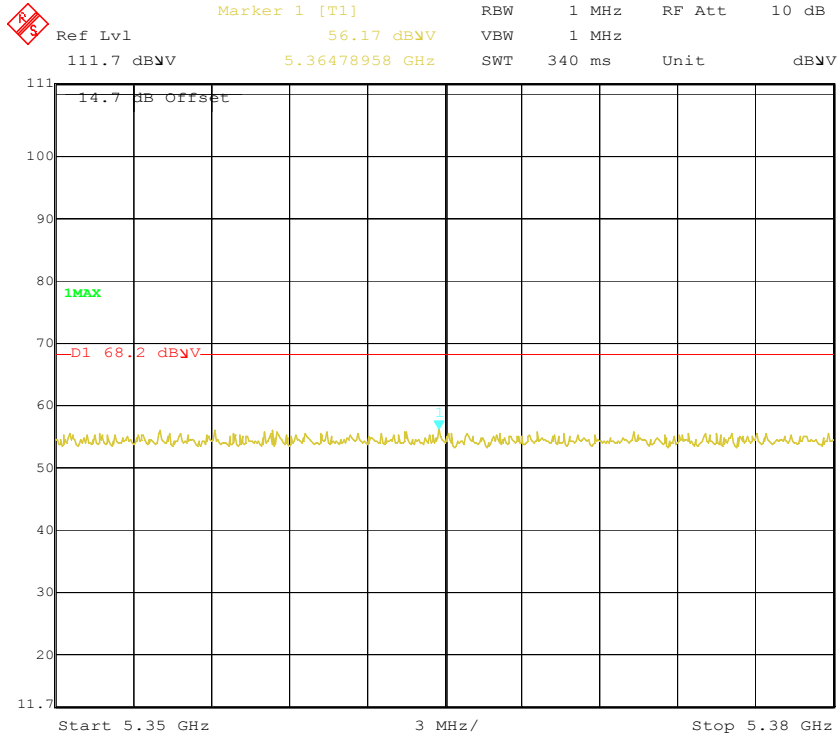

High Channel (16MHz Mode 2)

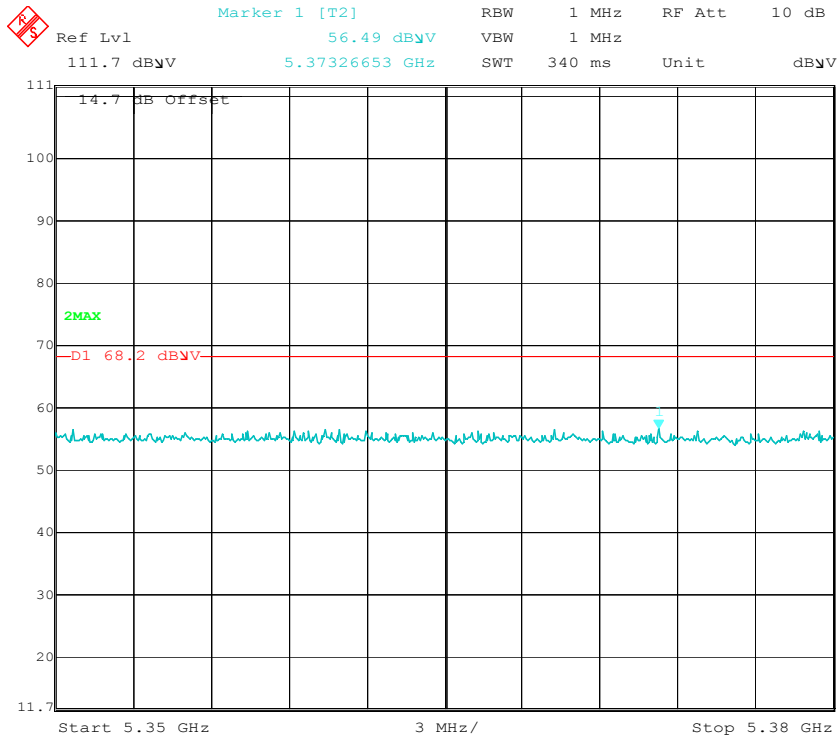

High Channel (16MHz Mode 3)

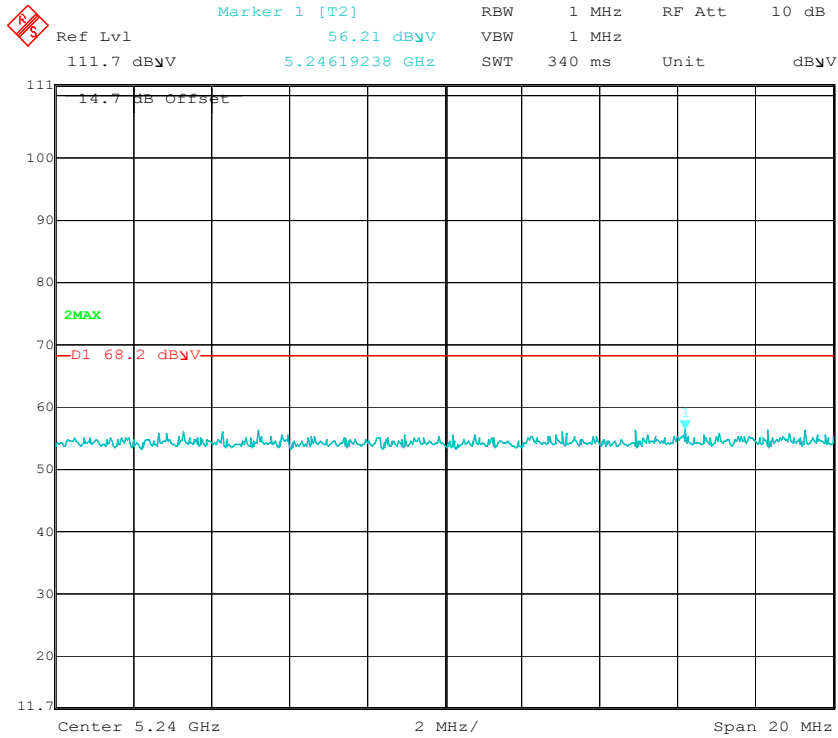

Low Channel (32MHz Mode 1)

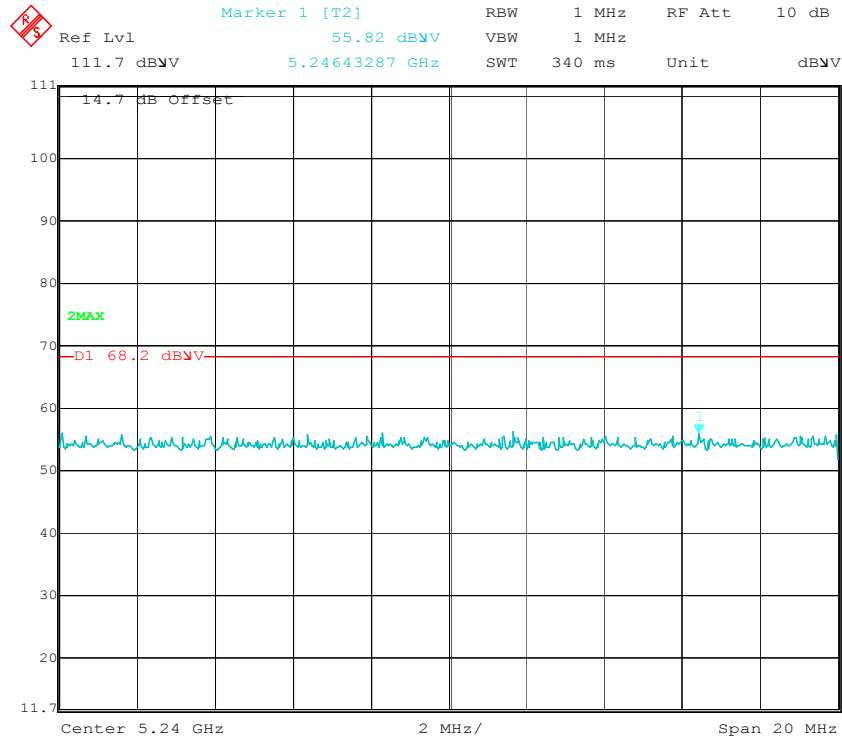

Low Channel (32MHz Mode 2)

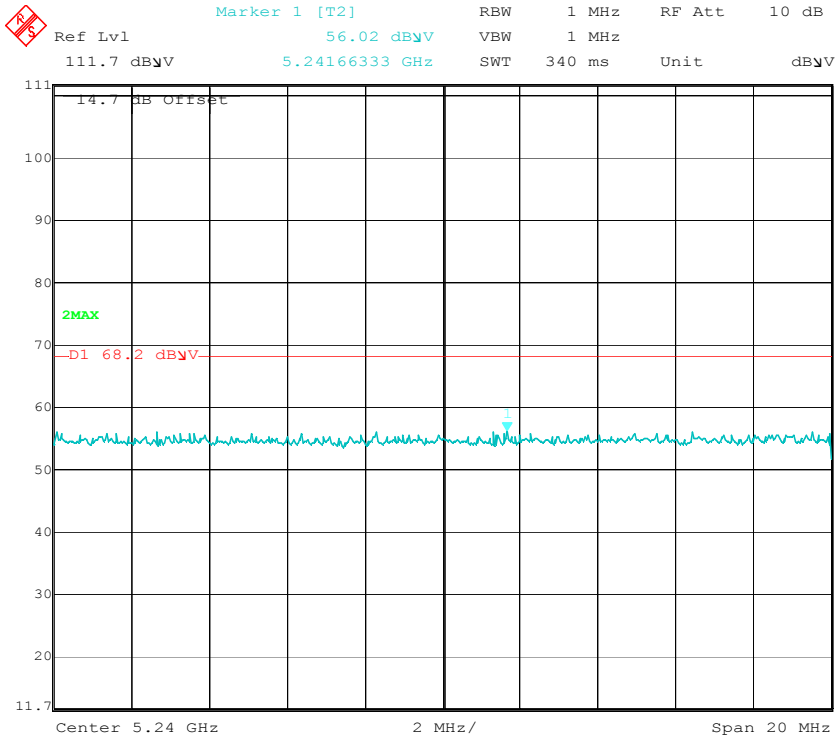

Low Channel (32MHz Mode 3)

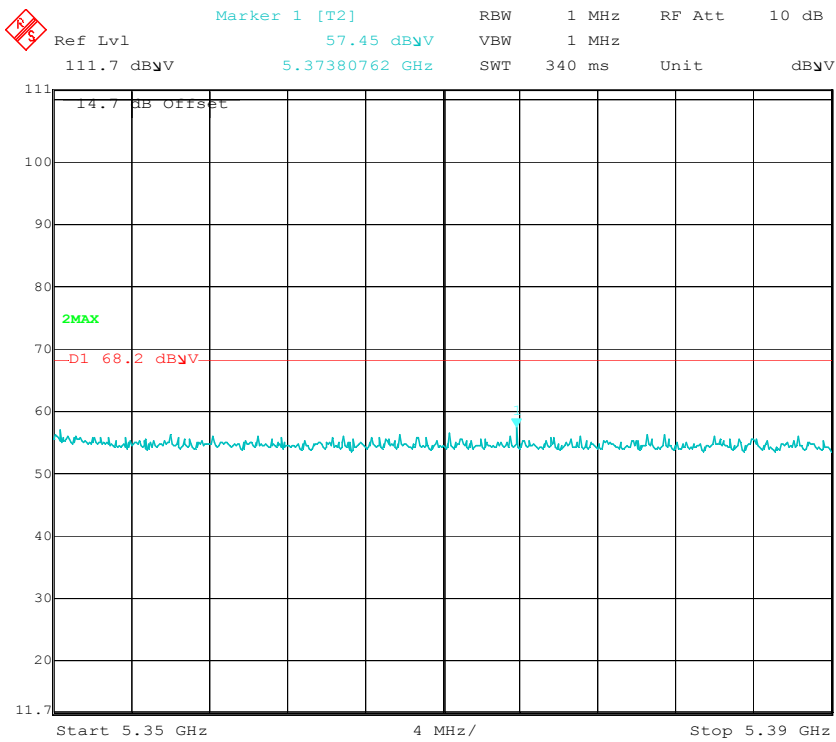

High Channel (32MHz Mode 1)

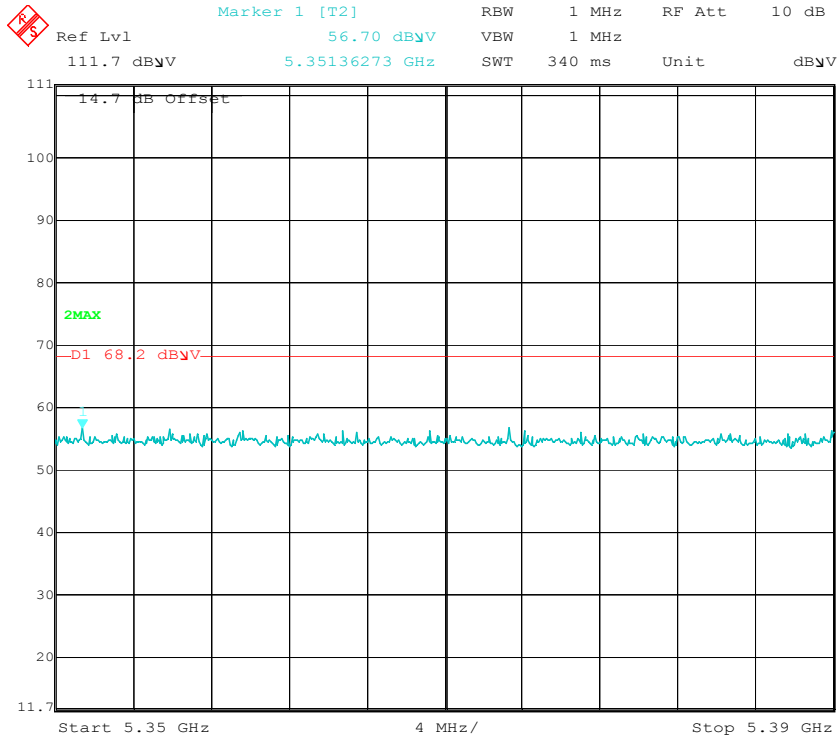

High Channel (32MHz Mode 2)

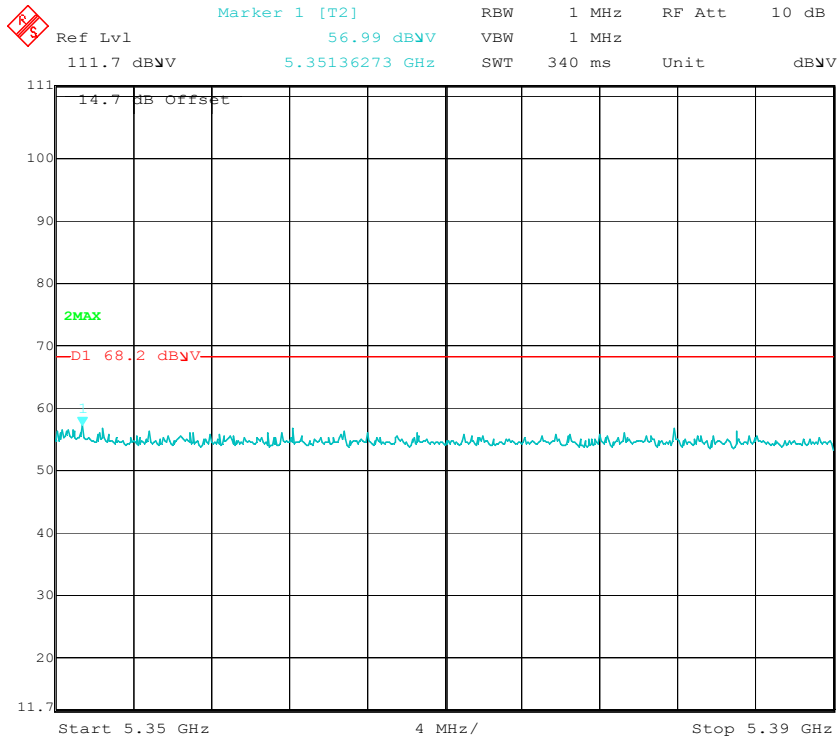

High Channel (32MHz Mode 3)

Horizontal Polarity

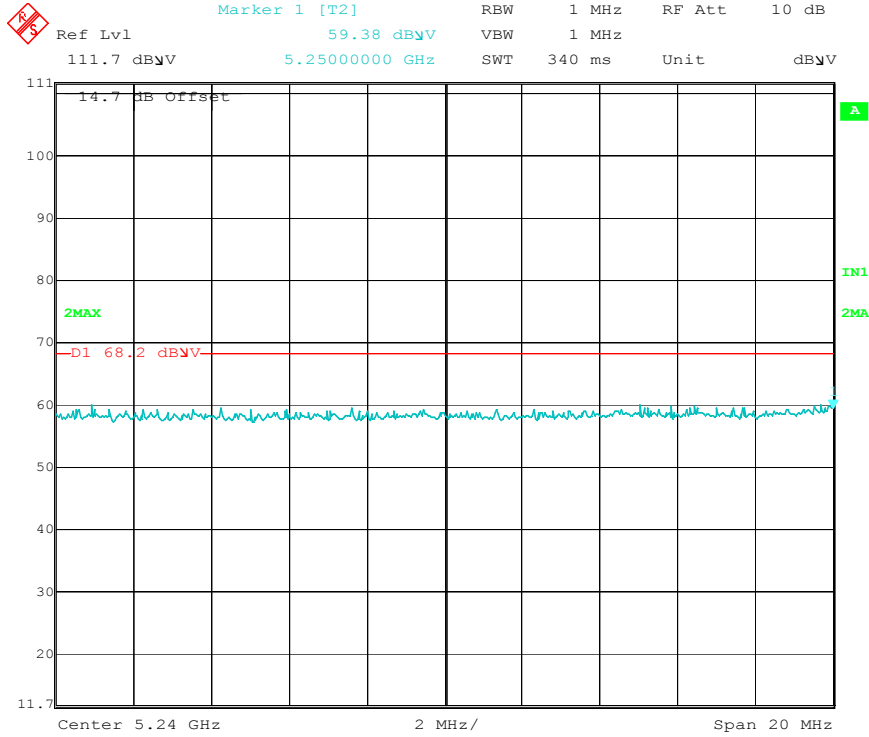

Low Channel (8MHz Mode 1)

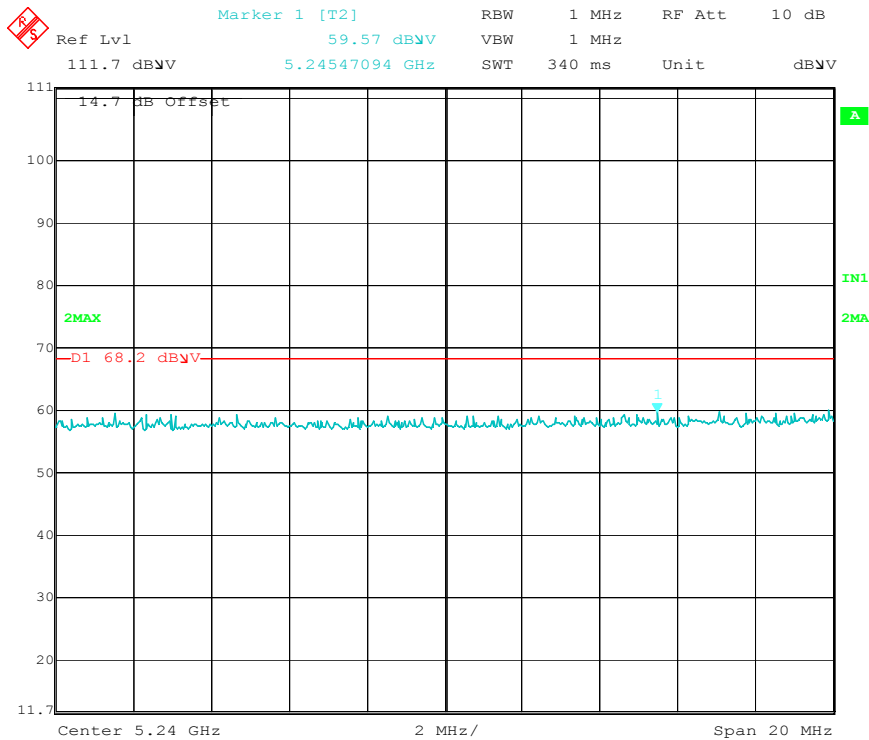

Low Channel (8MHz Mode 2)

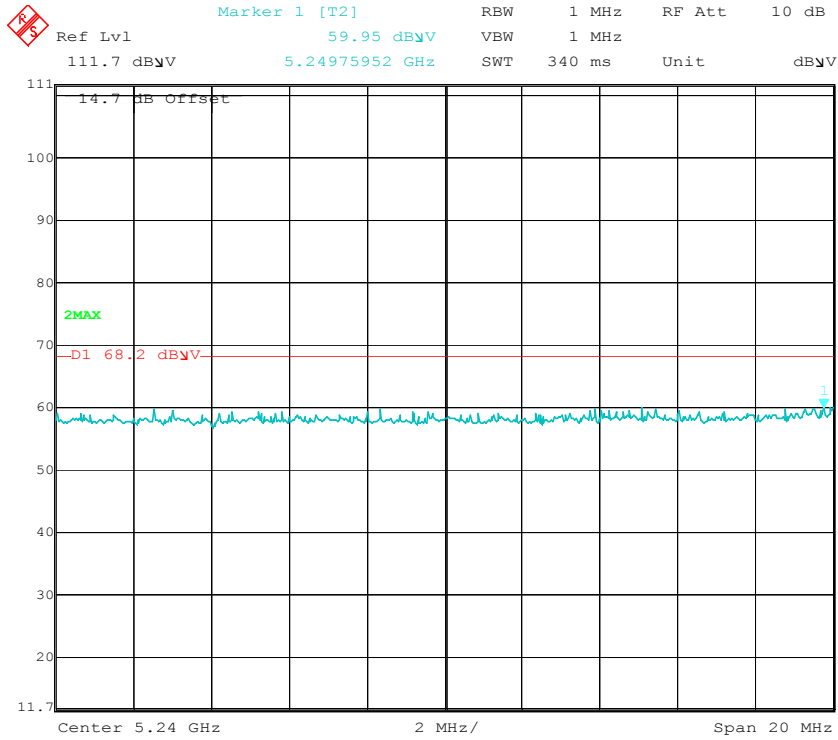

Low Channel (8MHz Mode 3)

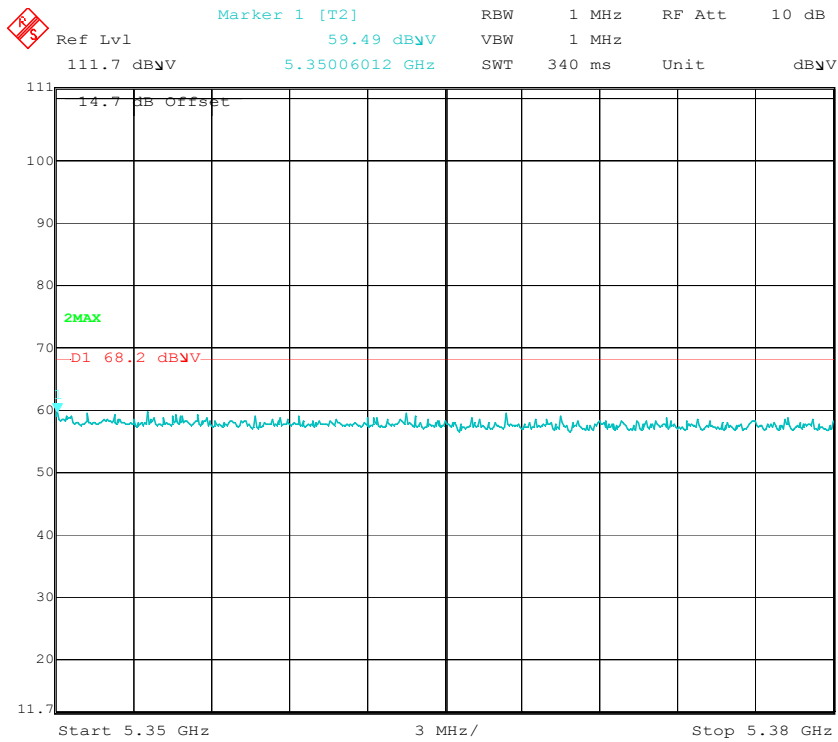

High Channel (8MHz Mode 1)

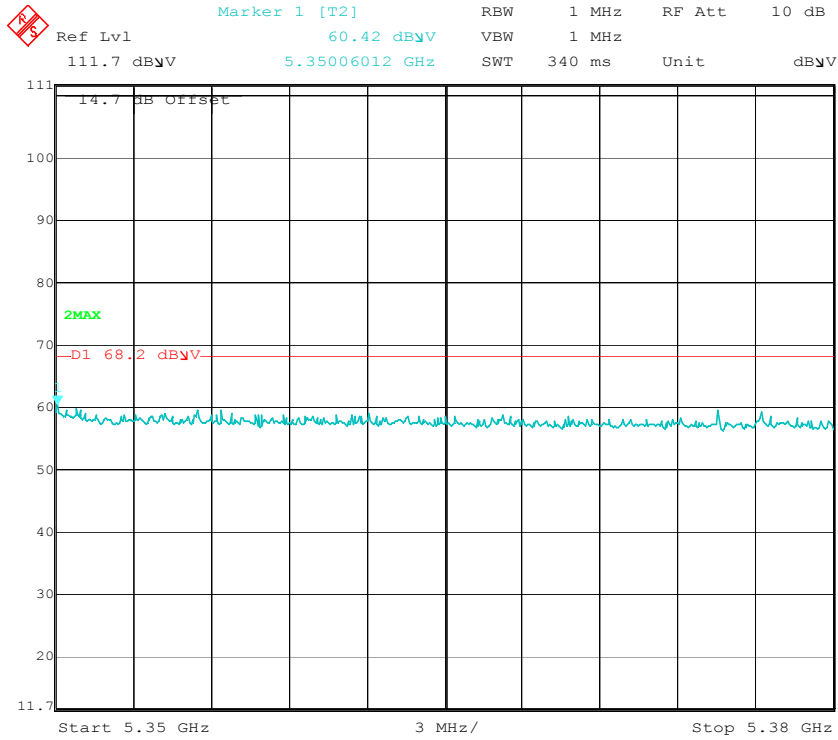

High Channel (8MHz Mode 2)

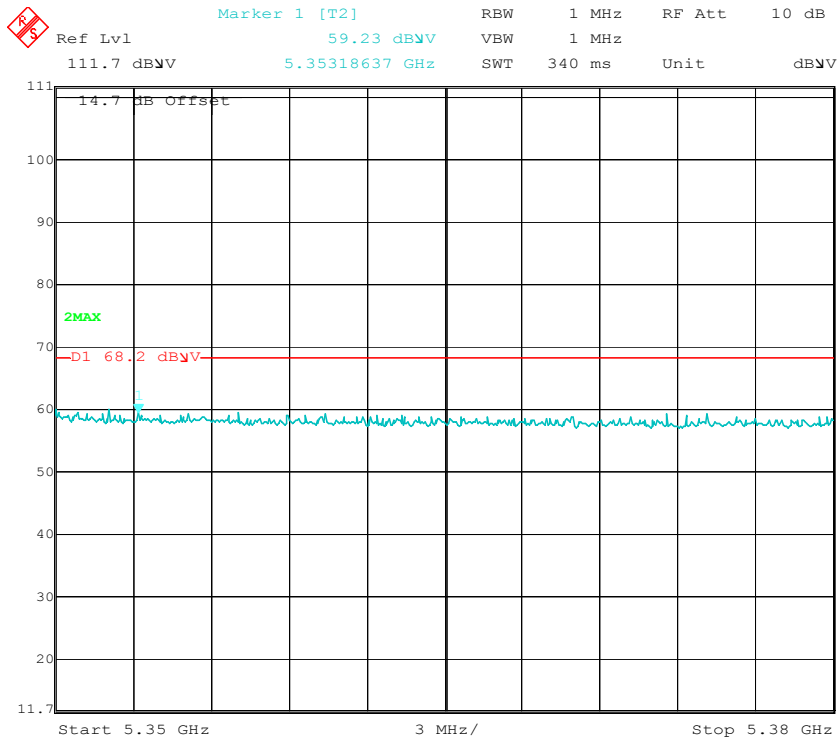

High Channel (8MHz Mode 3)

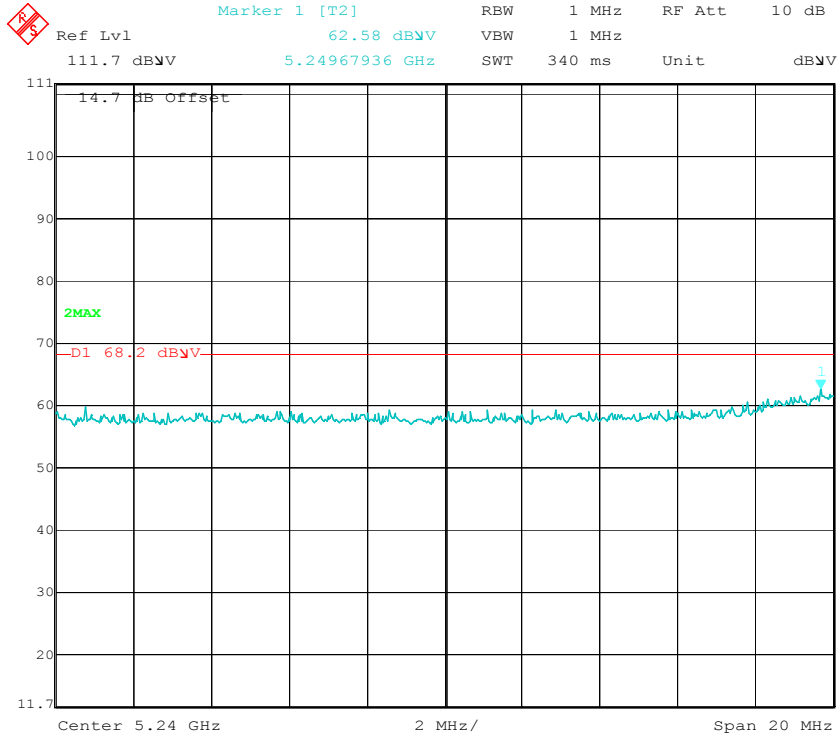

Low Channel (16MHz Mode 1)

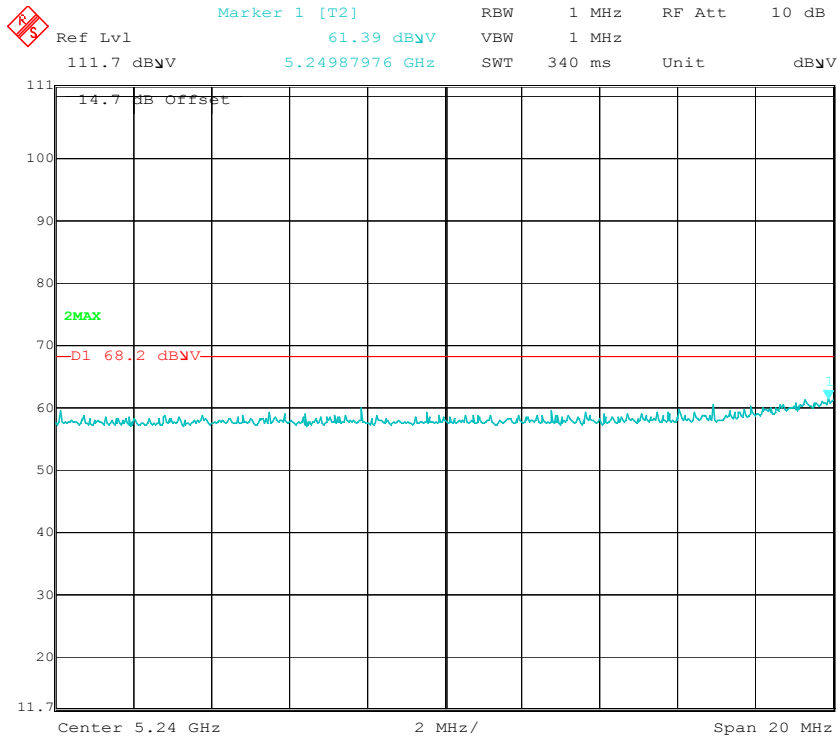

Low Channel (16MHz Mode 2)

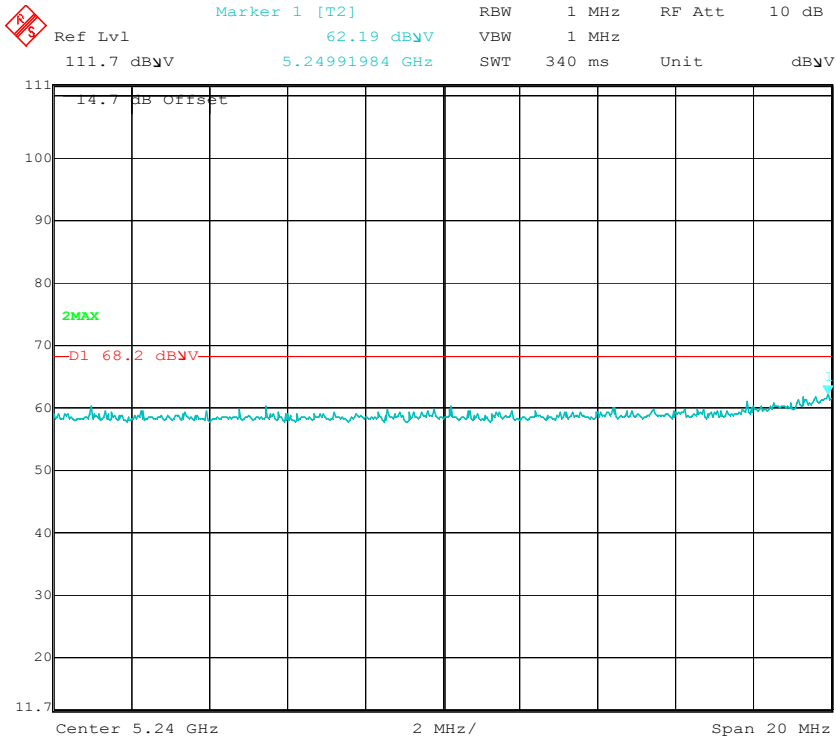

Low Channel (16MHz Mode 3)

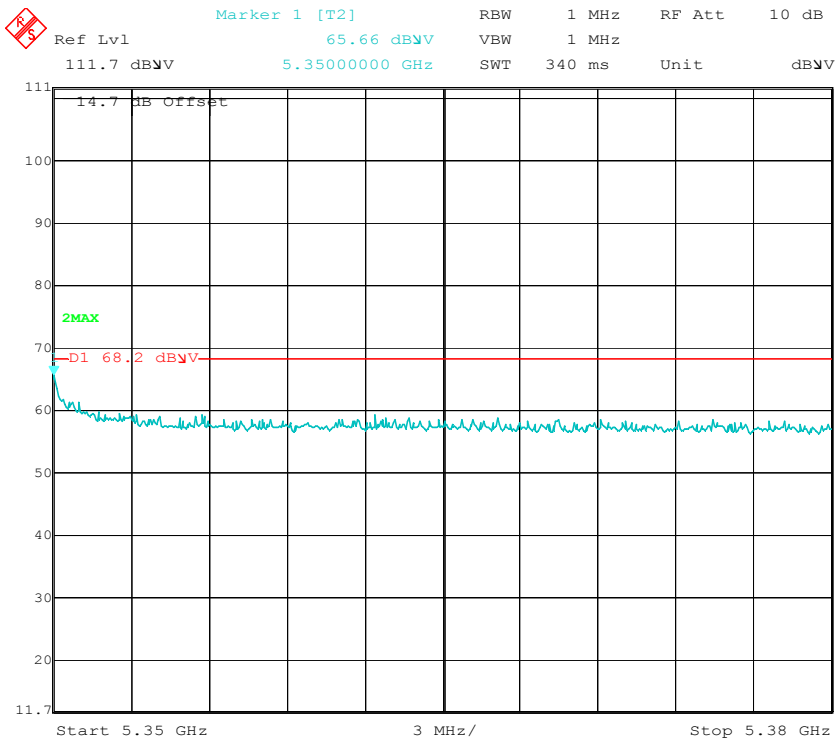

High Channel (16MHz Mode 1)

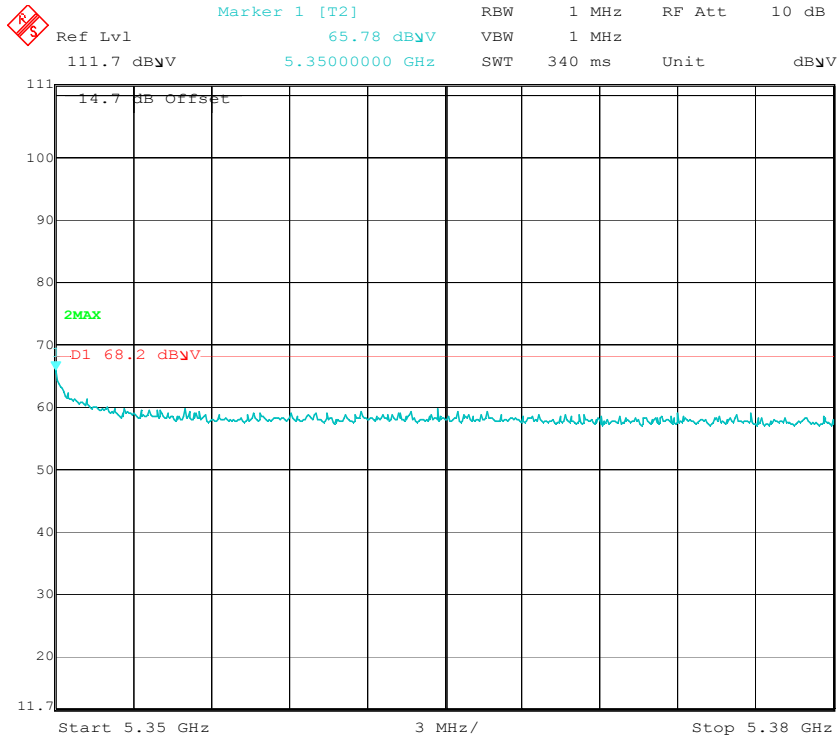

High Channel (16MHz Mode 2)

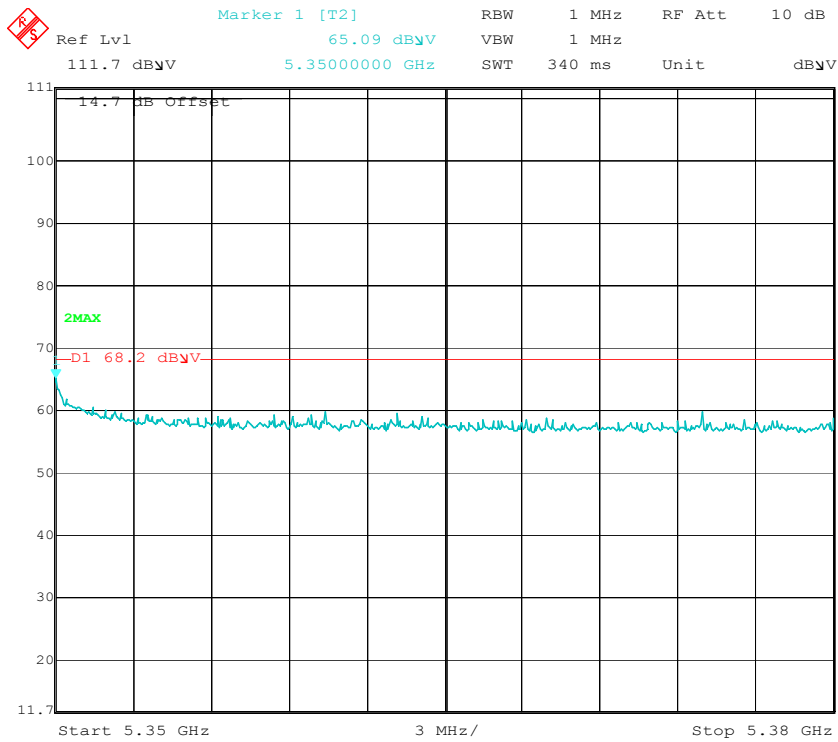

High Channel (16MHz Mode 3)

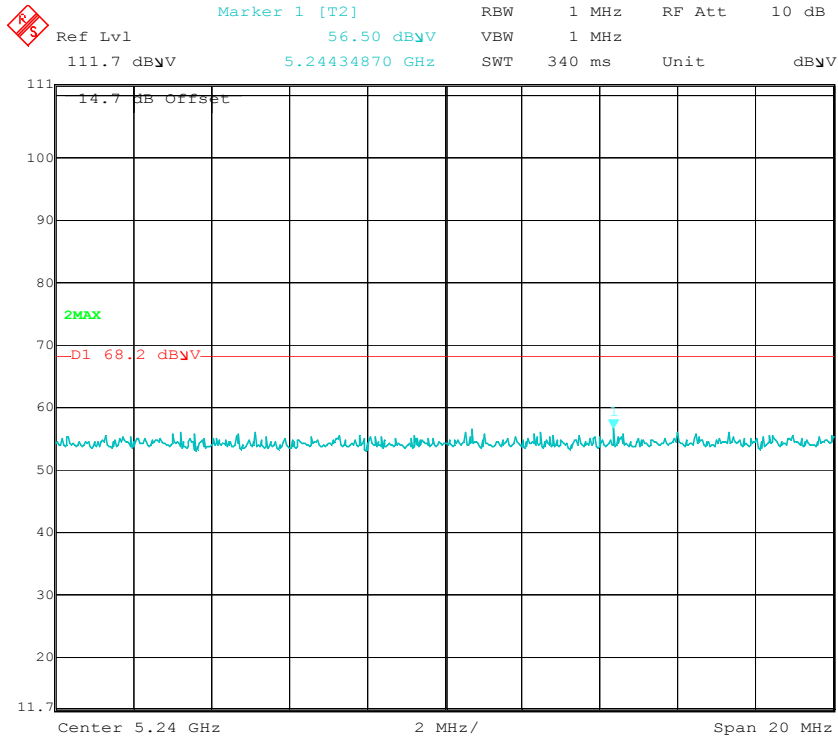

Low Channel (32MHz Mode 1)

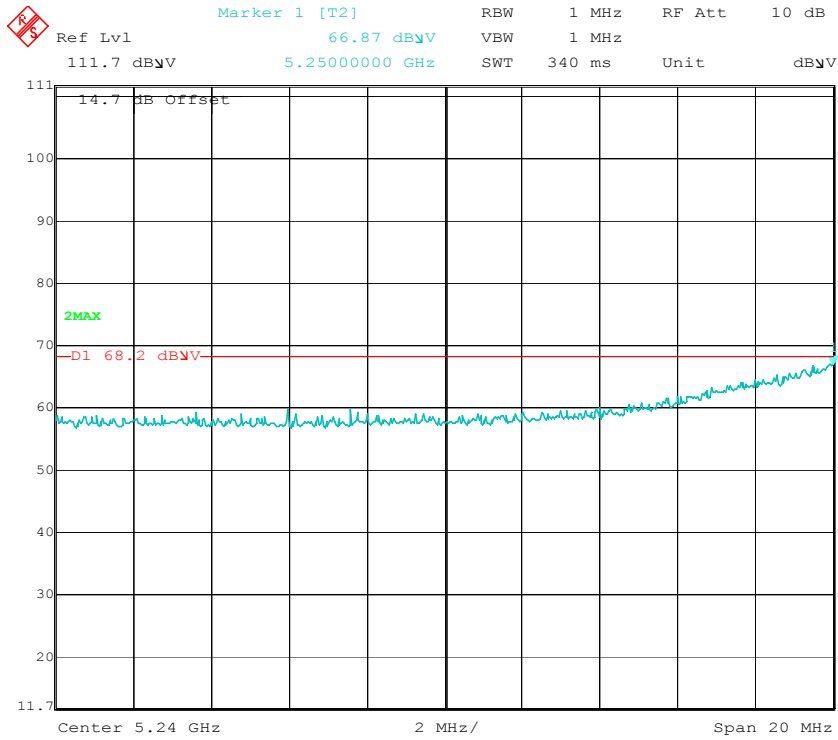

Low Channel (32MHz Mode 2)

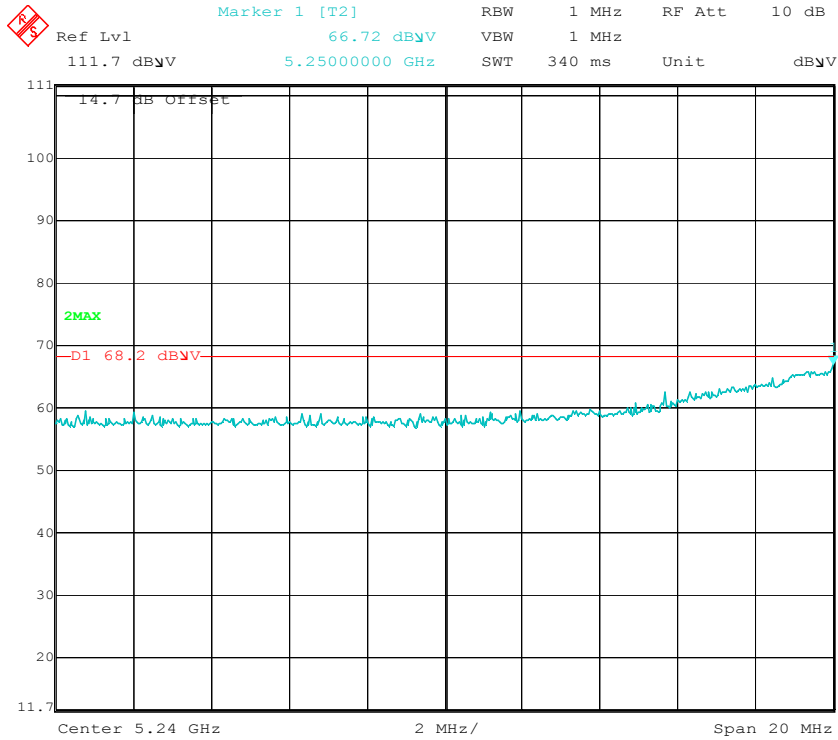

Low Channel (32MHz Mode 3)

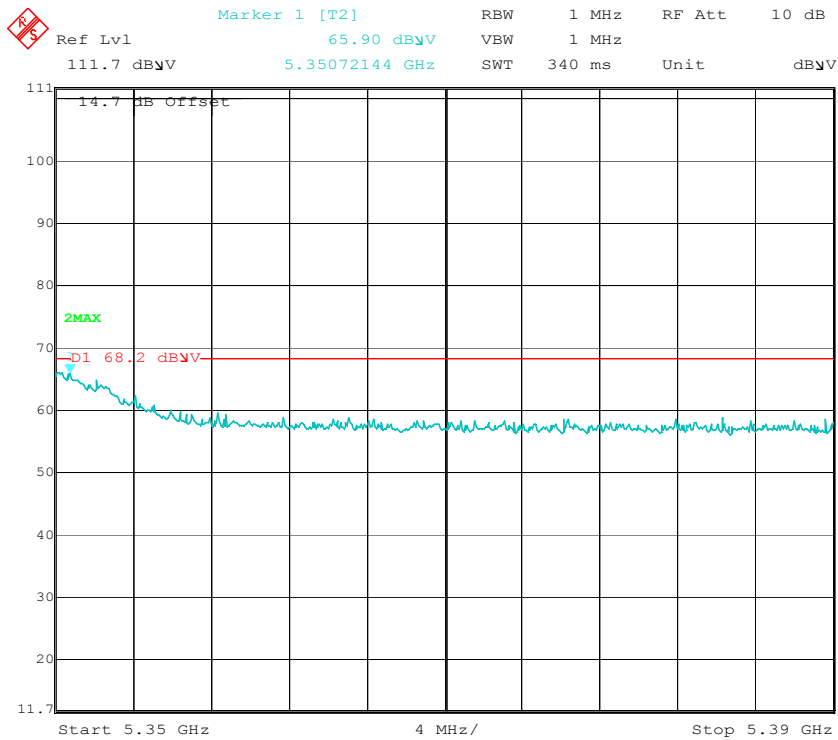

High Channel (32MHz Mode 1)

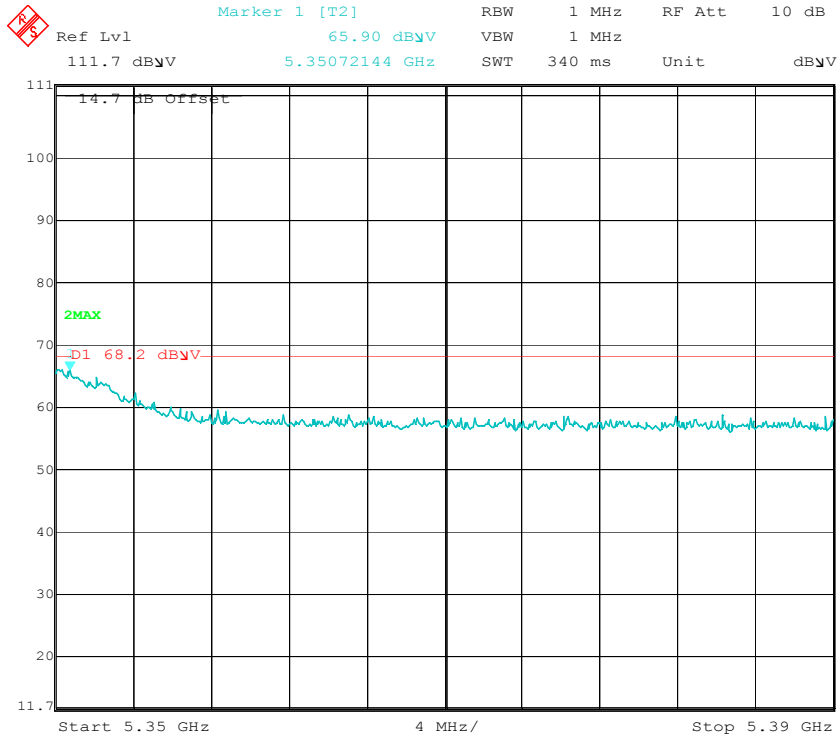

High Channel (32MHz Mode 2)

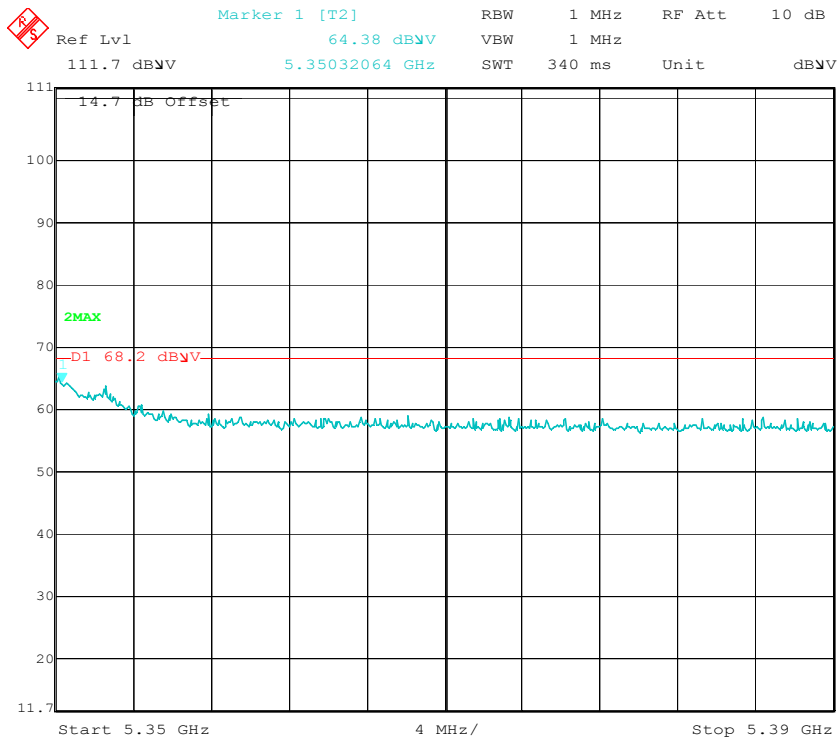

High Channel (32MHz Mode 3)



RF S Marker 1 [T2] RBW 1 MHz RF Att 10 dB
Ref Lvl 50.72 dBmV VBW 1 MHz
111.7 dBmV 5.46959920 GHz SWT 5 ms Unit dBmV

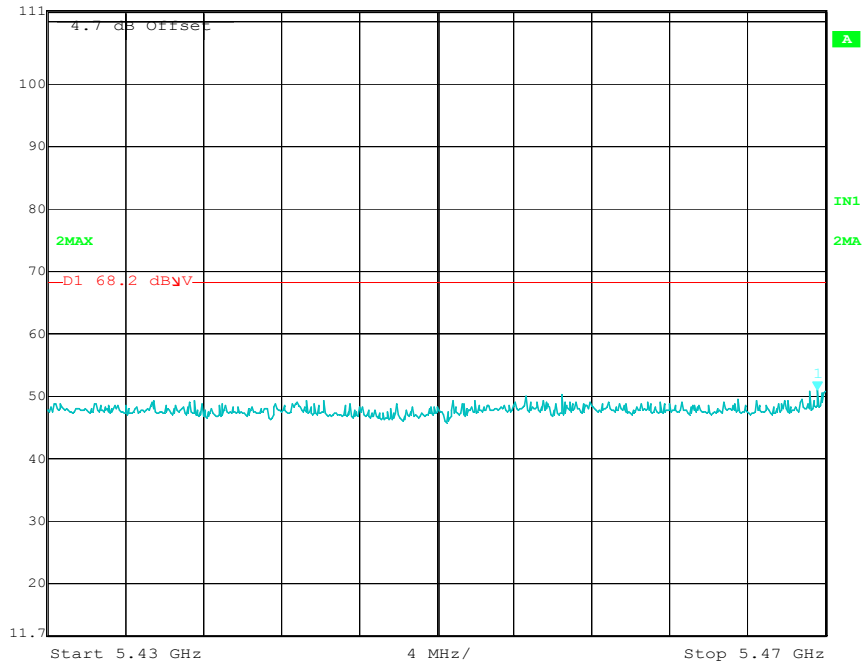

Low Channel (8MHz Mode 3)

RF S Marker 1 [T2] RBW 1 MHz RF Att 10 dB
Ref Lvl 50.11 dBmV VBW 1 MHz
111.7 dBmV 5.72515030 GHz SWT 5 ms Unit dBmV

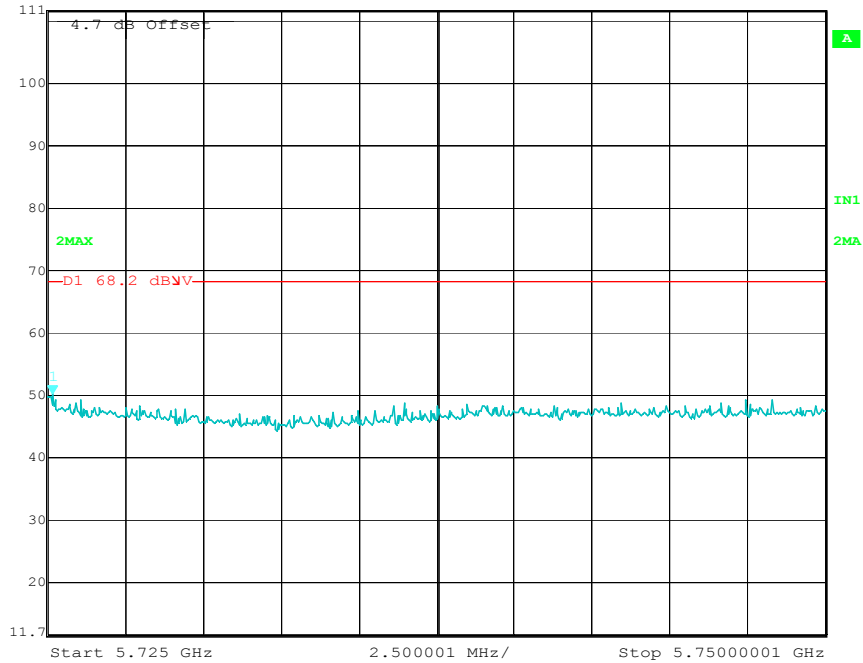

High Channel (8MHz Mode 1)

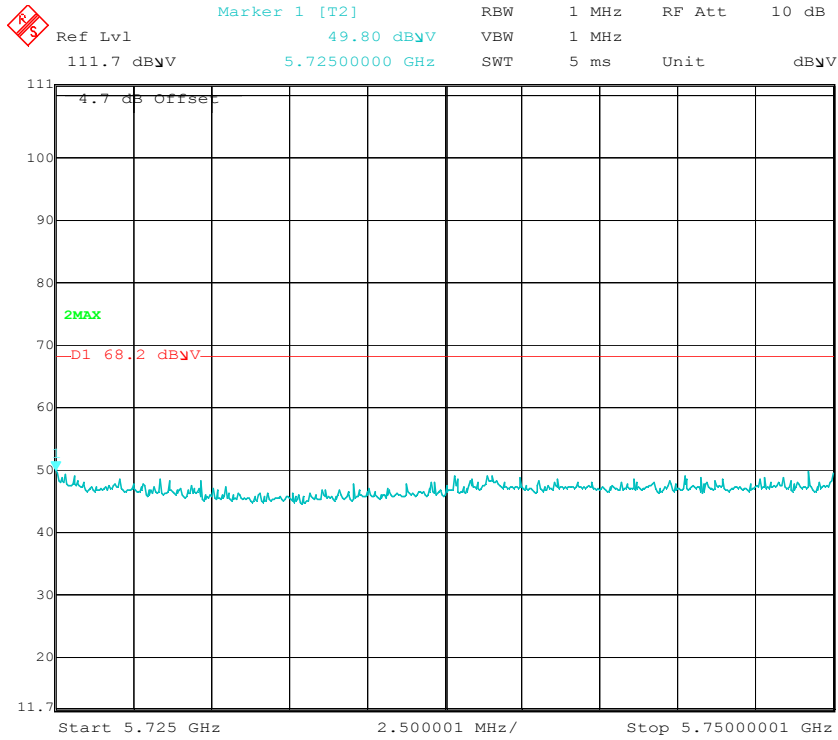

High Channel (8MHz Mode 2)

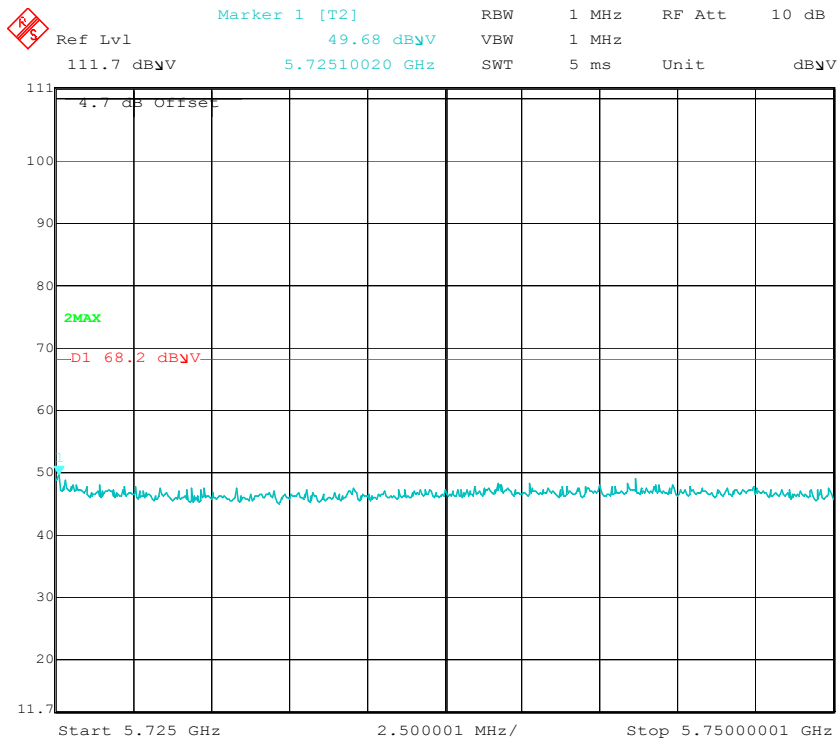

High Channel (8MHz Mode 3)

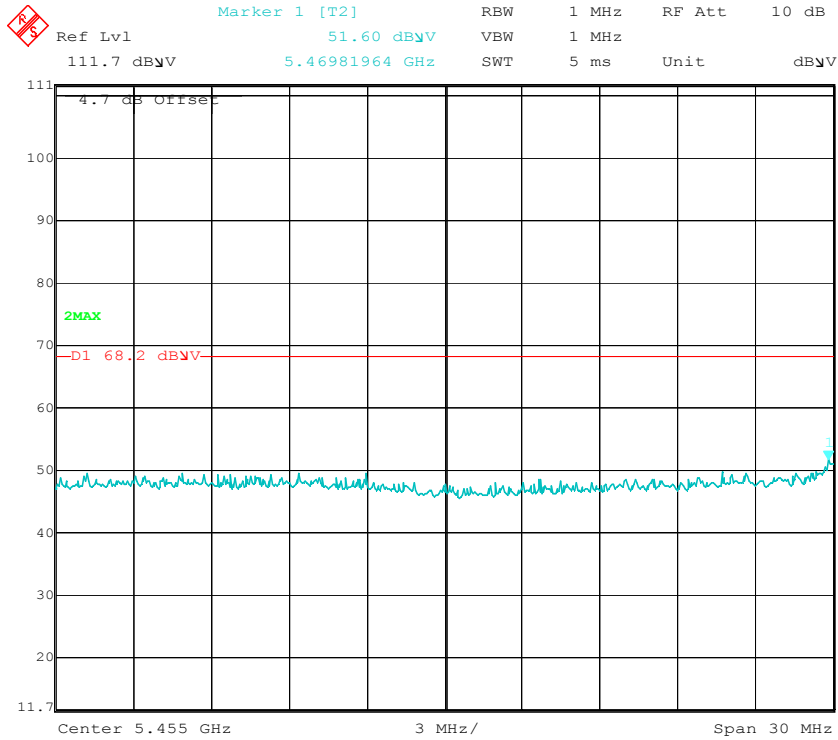

Low Channel (16MHz Mode 1)

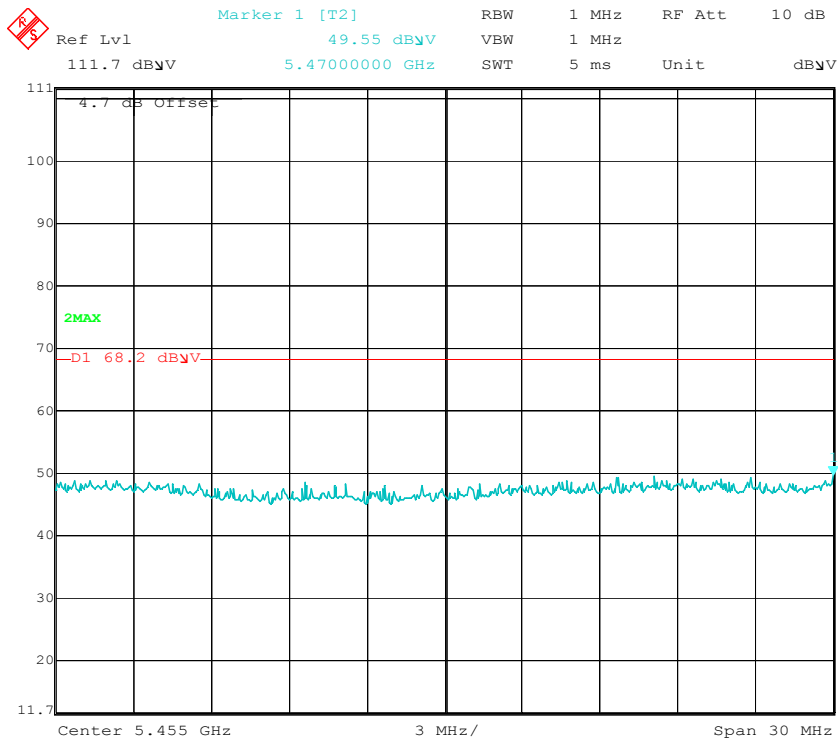

Low Channel (16MHz Mode 2)

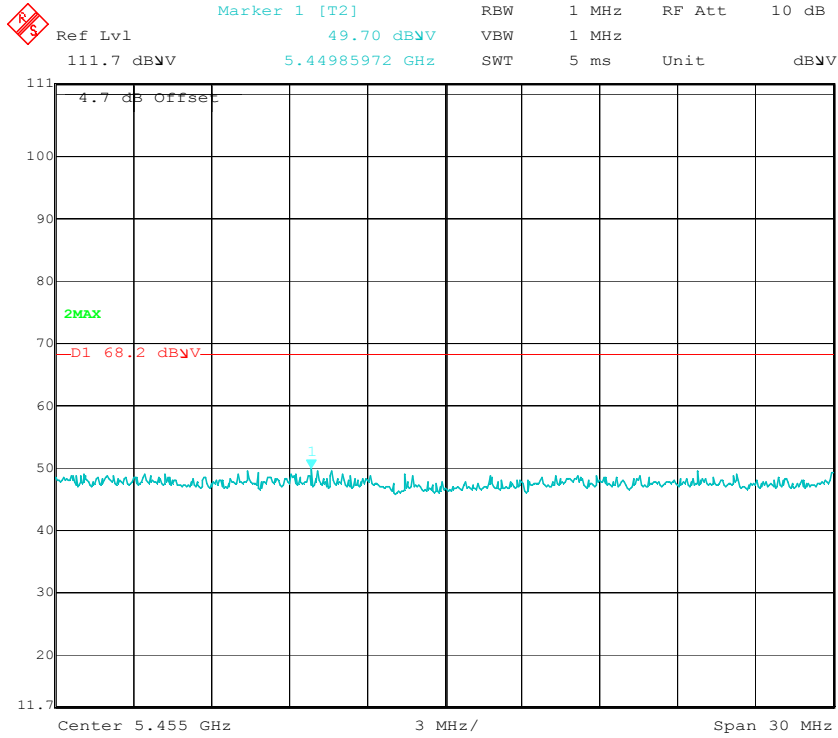

Low Channel (16MHz Mode 3)

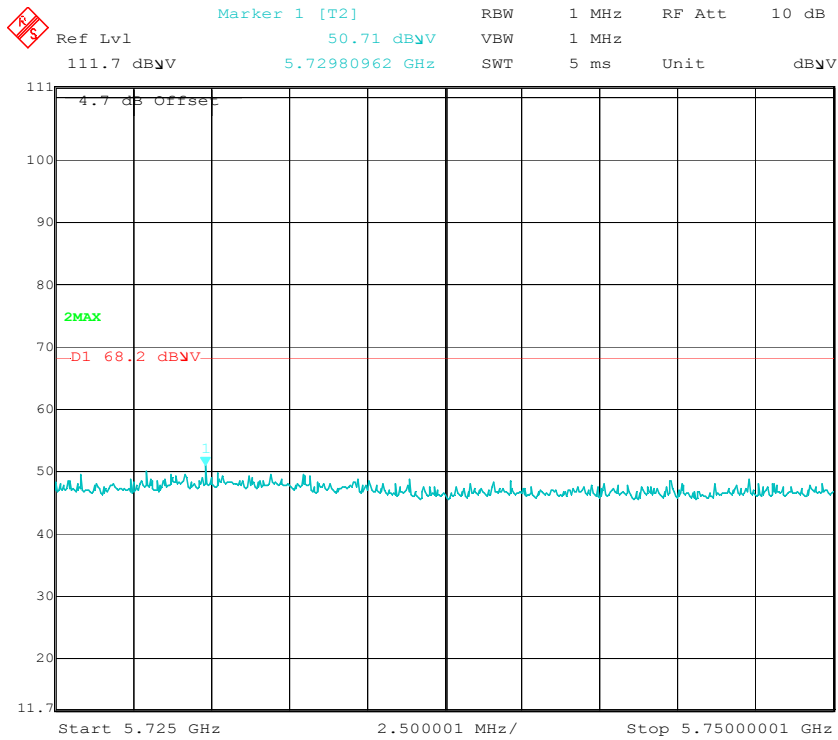

High Channel (16MHz Mode 1)

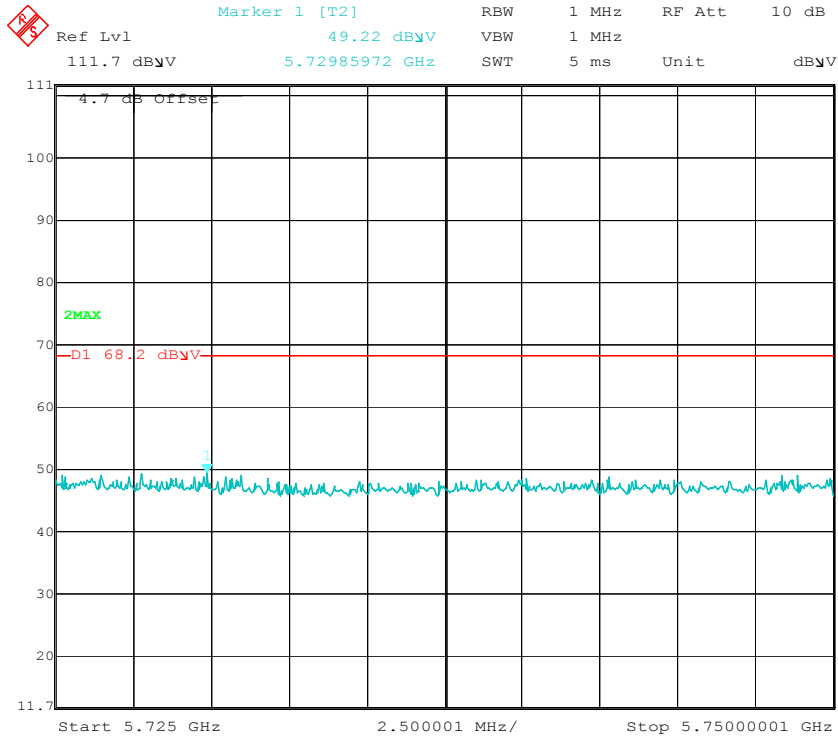

High Channel (16MHz Mode 2)

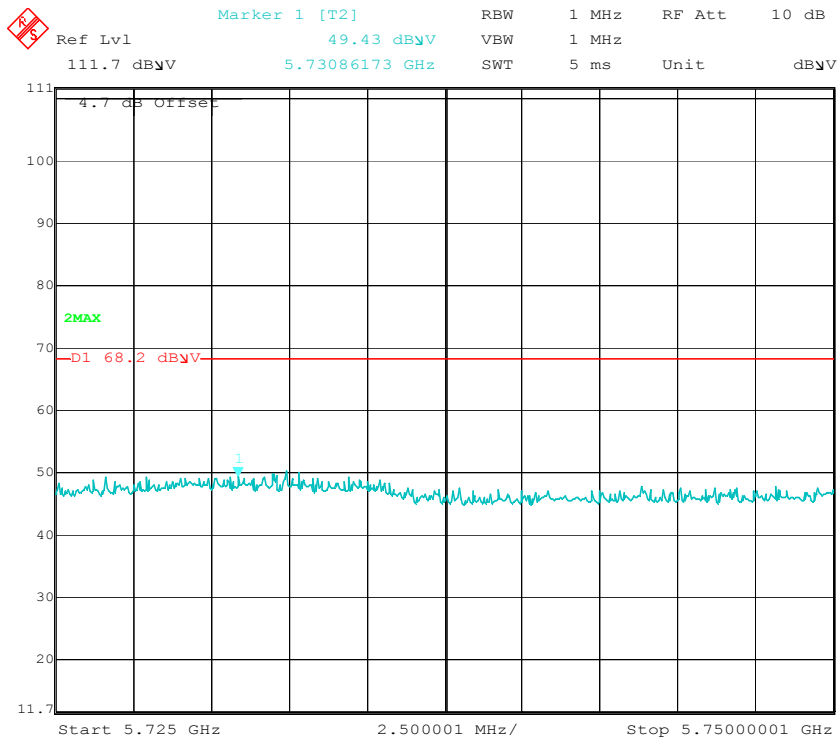

High Channel (16MHz Mode 3)

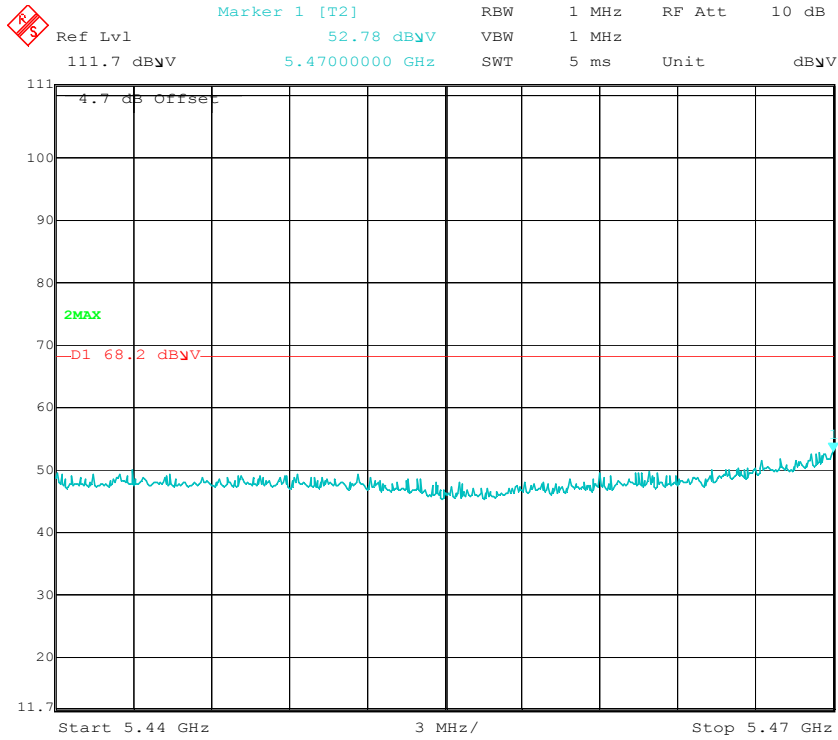

Low Channel (32MHz Mode 1)

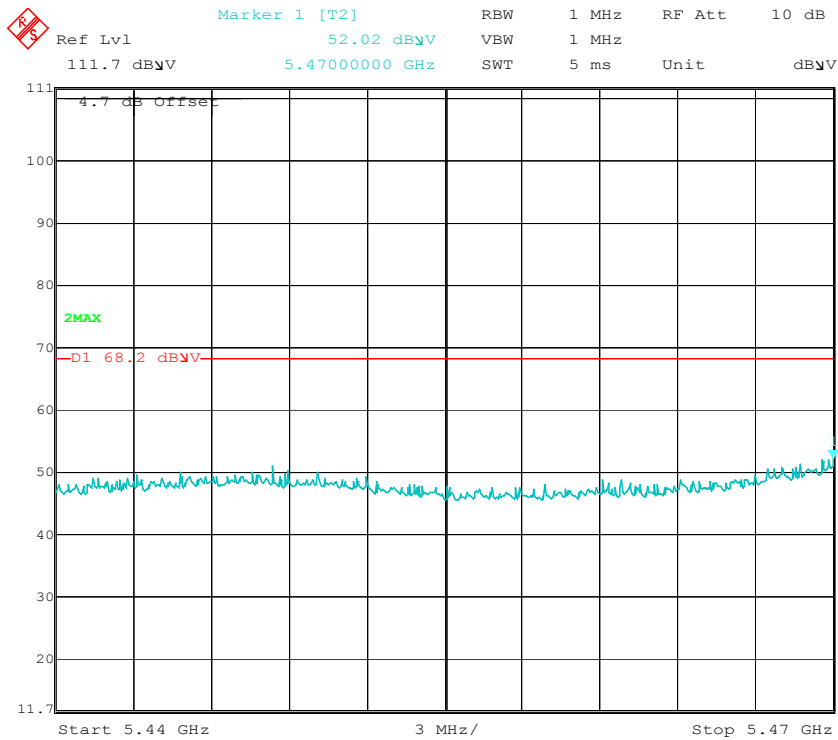

Low Channel (32MHz Mode 2)

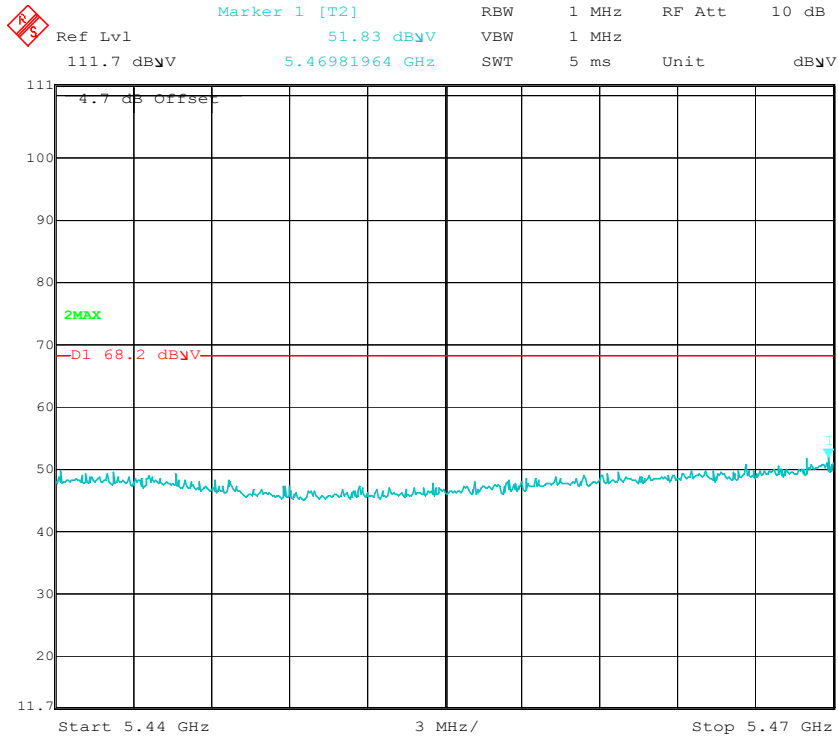

Low Channel (32MHz Mode 3)

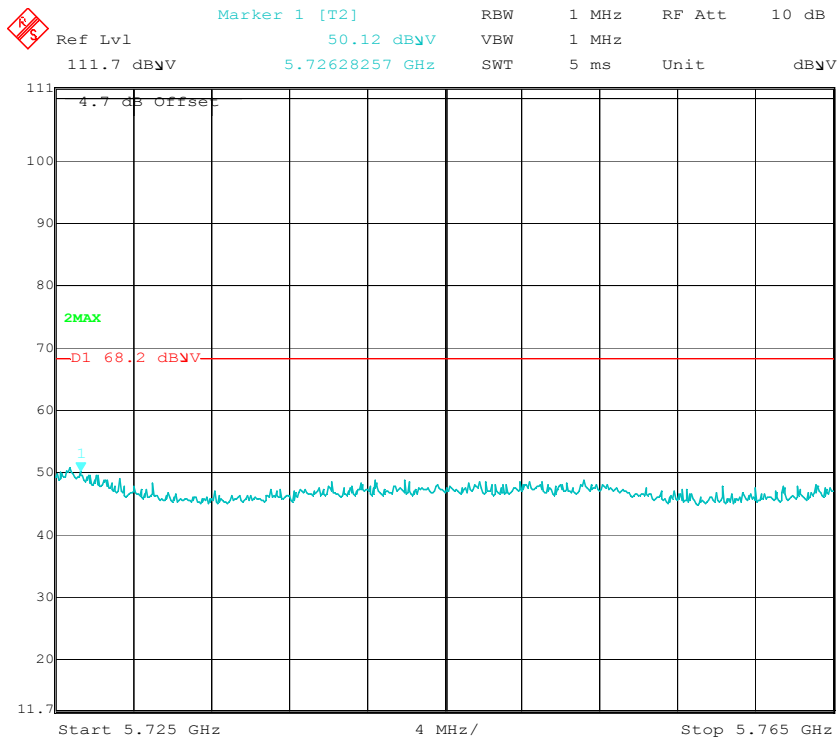

High Channel (32MHz Mode 1)

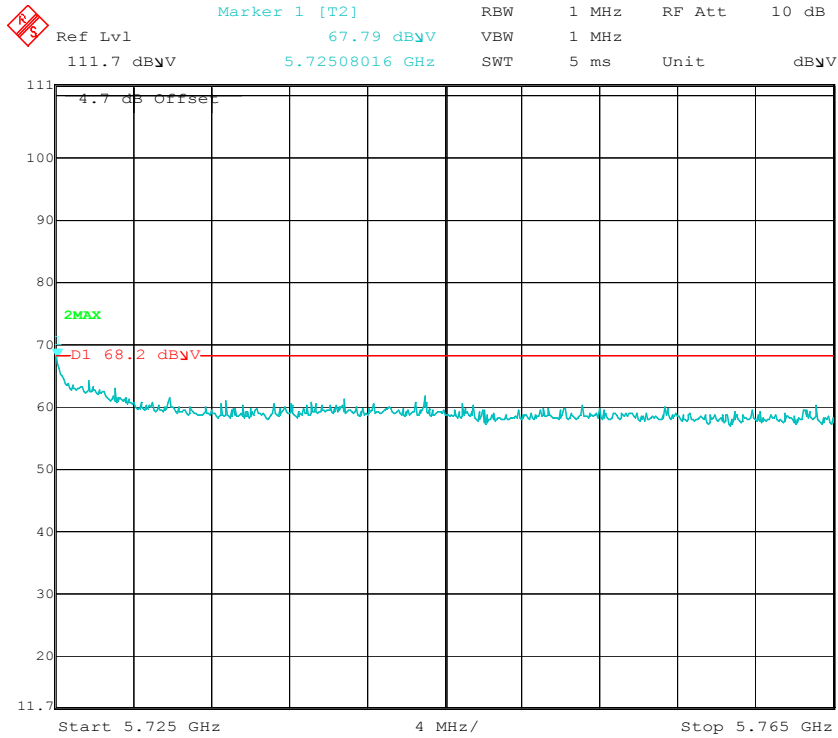

High Channel (32MHz Mode 2)

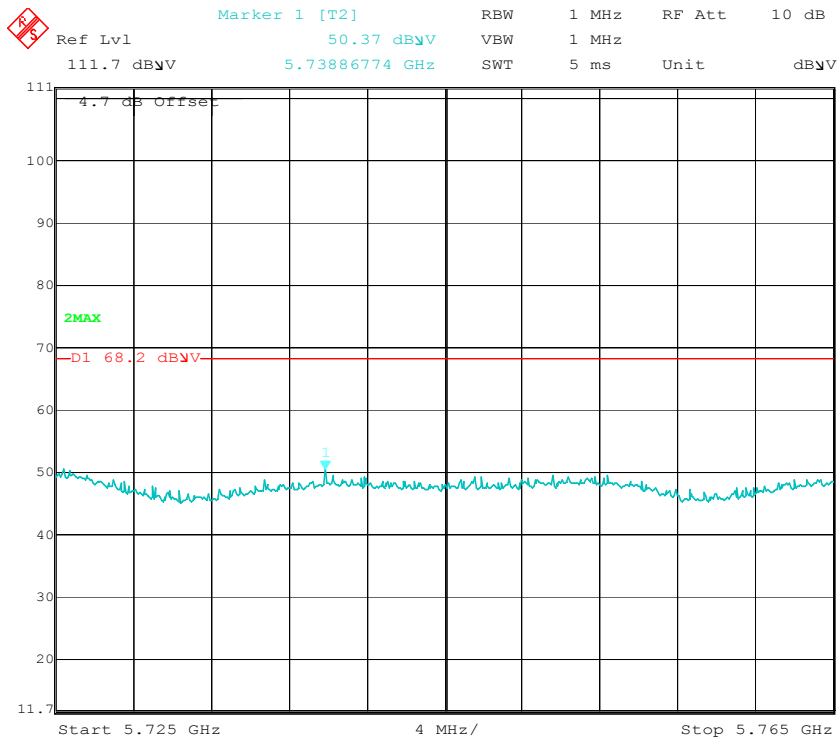

High Channel (32MHz Mode 3)

Horizontal Polarity

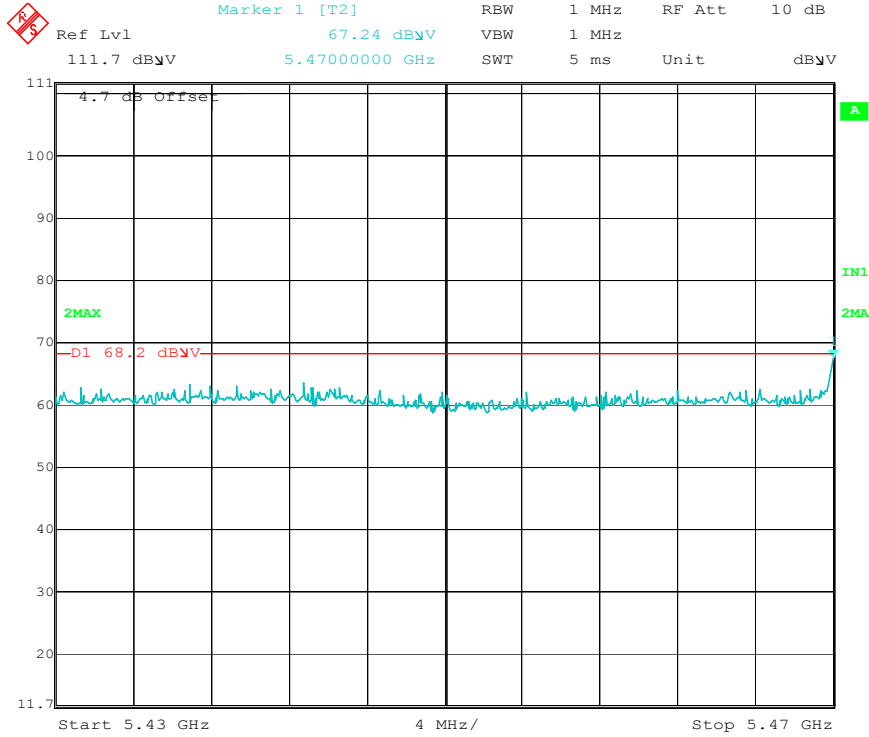

Low Channel (8MHz Mode 1)

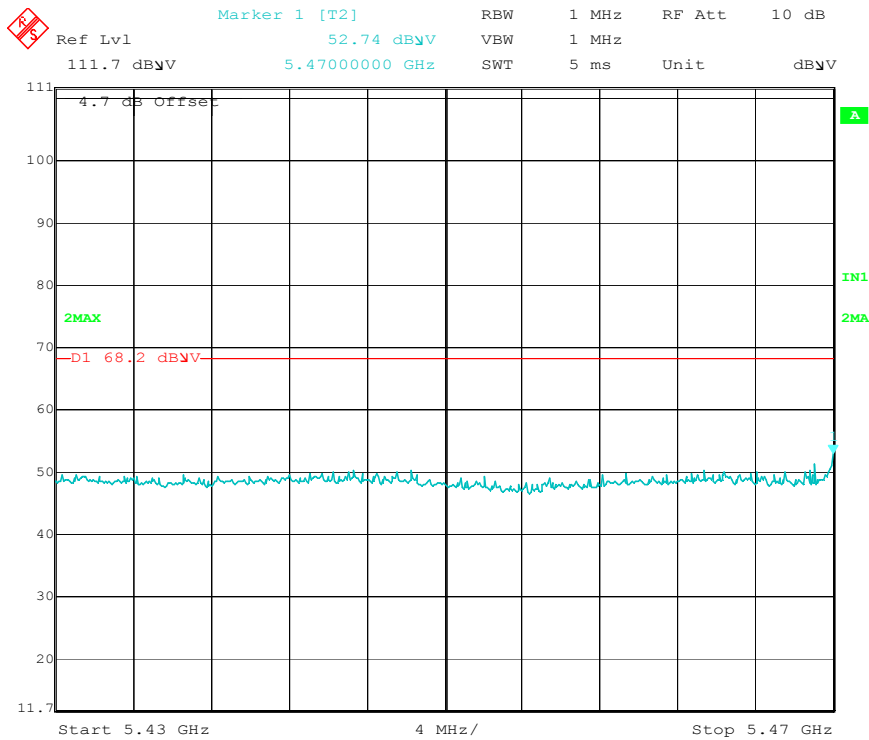

Low Channel (8MHz Mode 2)

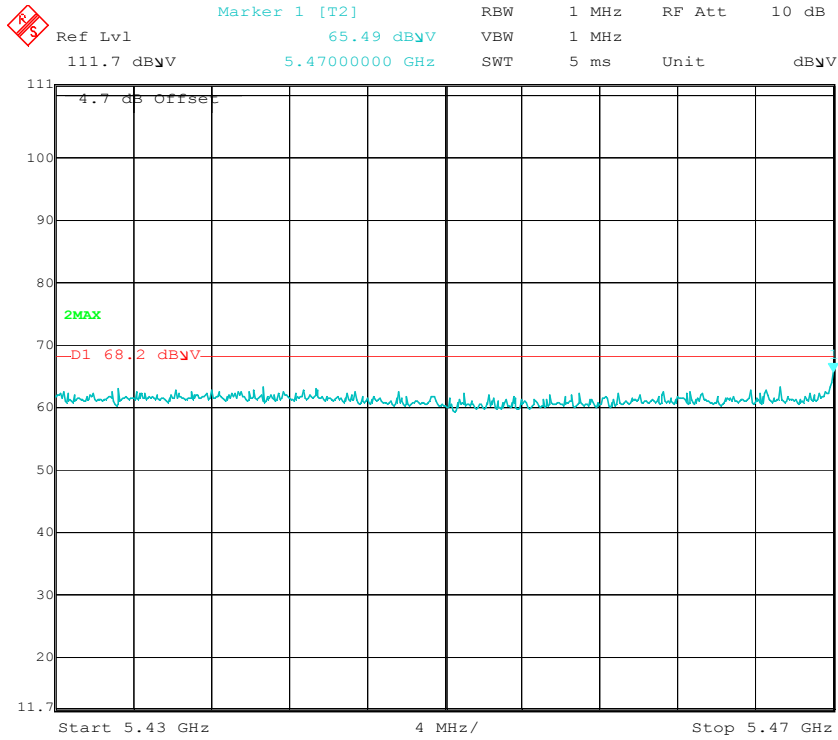

Low Channel (8MHz Mode 3)

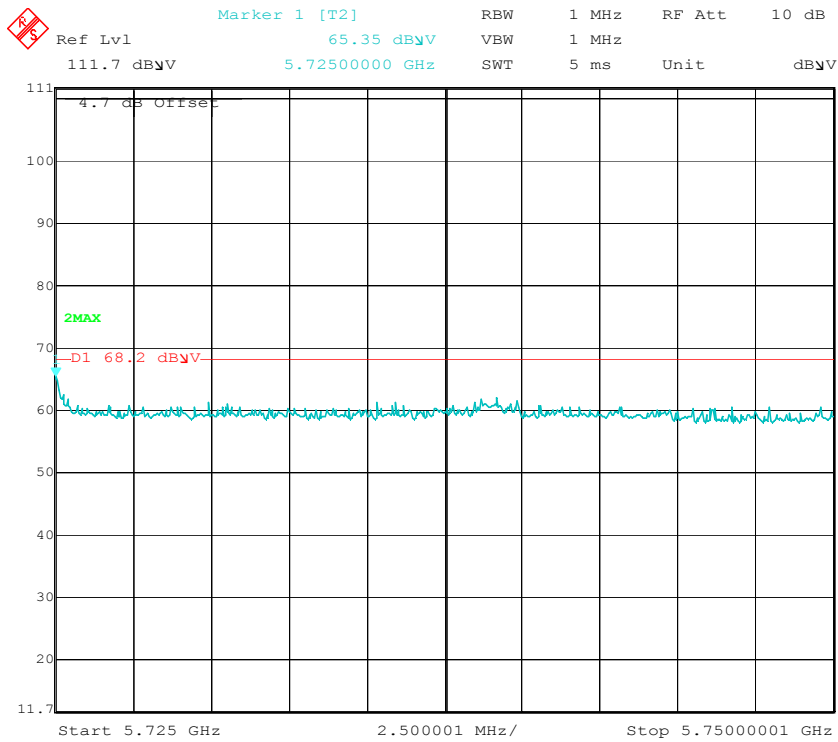

High Channel (8MHz Mode 1)

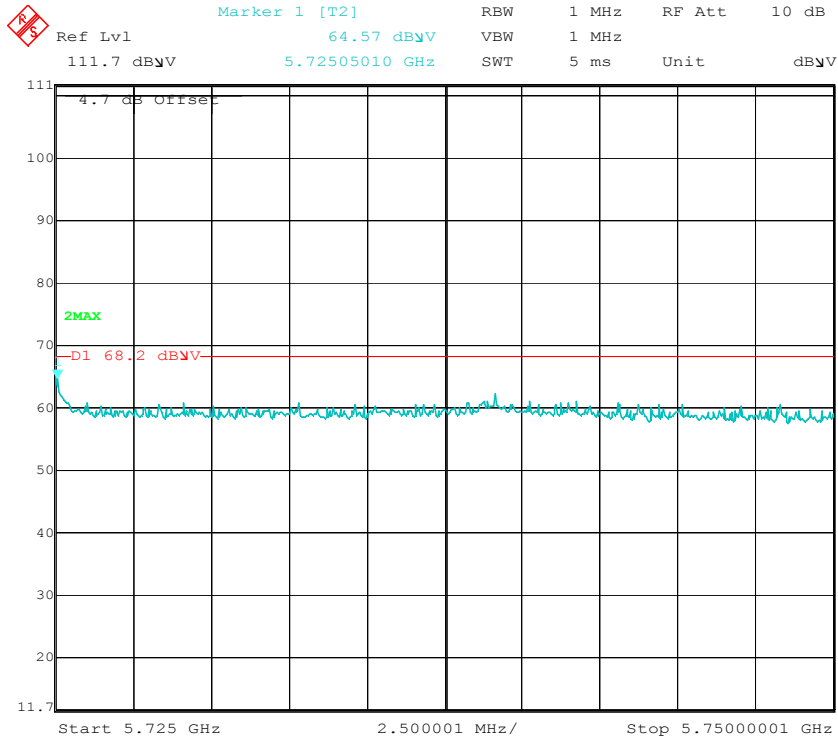

High Channel (8MHz Mode 2)

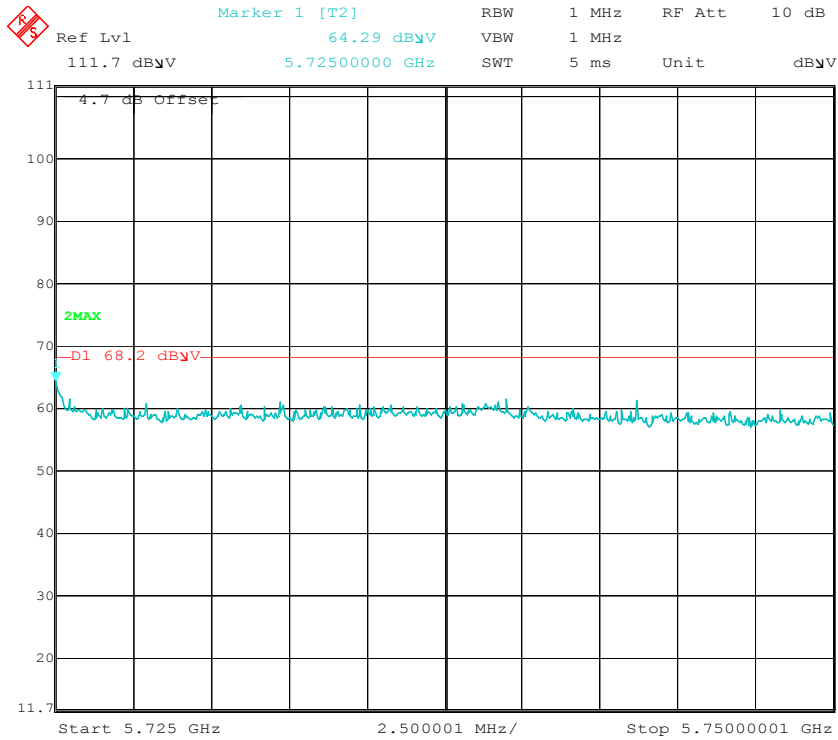

High Channel (8MHz Mode 3)

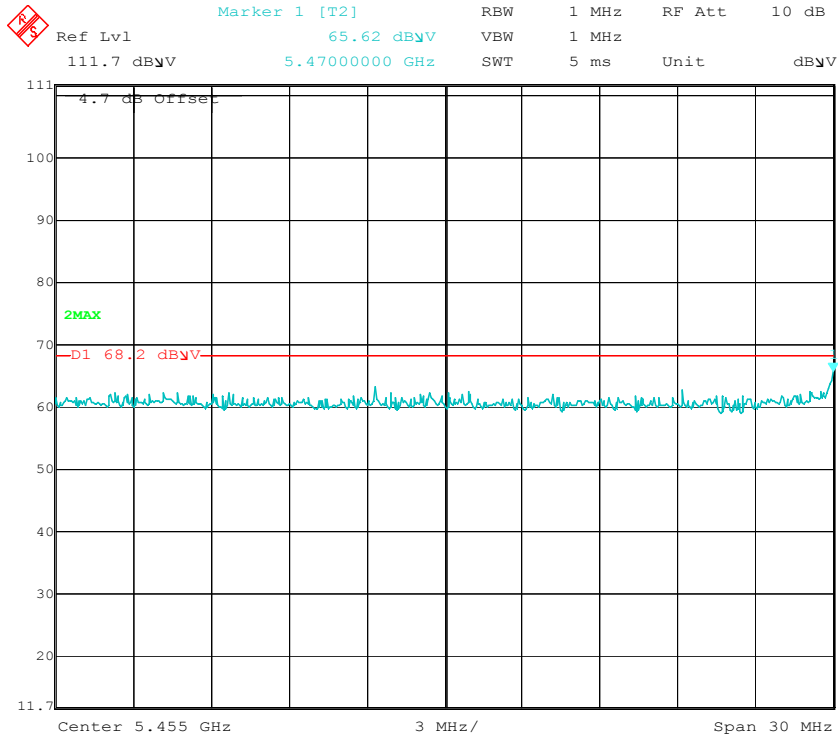

Low Channel (16MHz Mode 1)

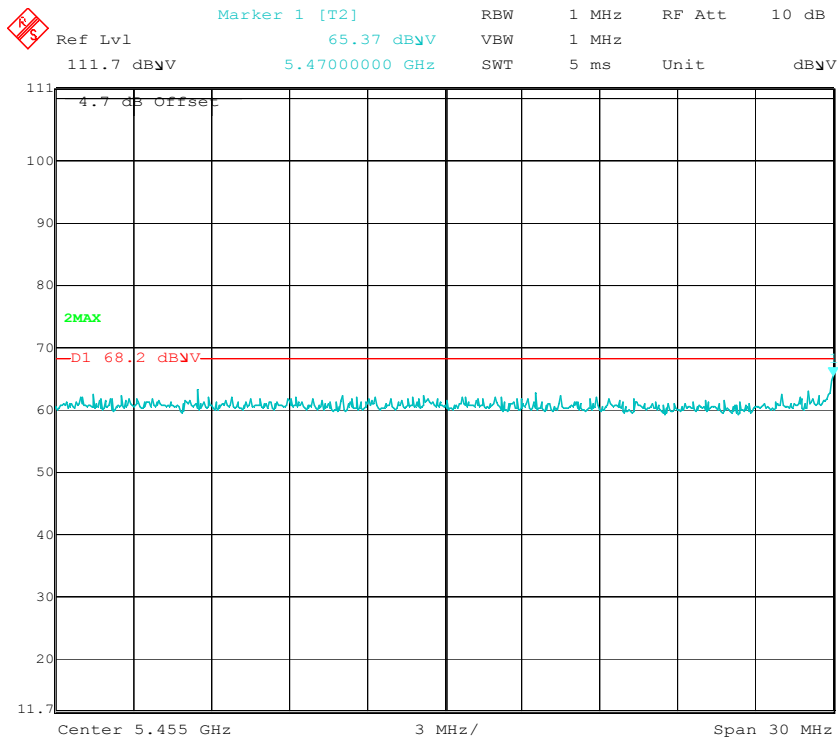

Low Channel (16MHz Mode 2)

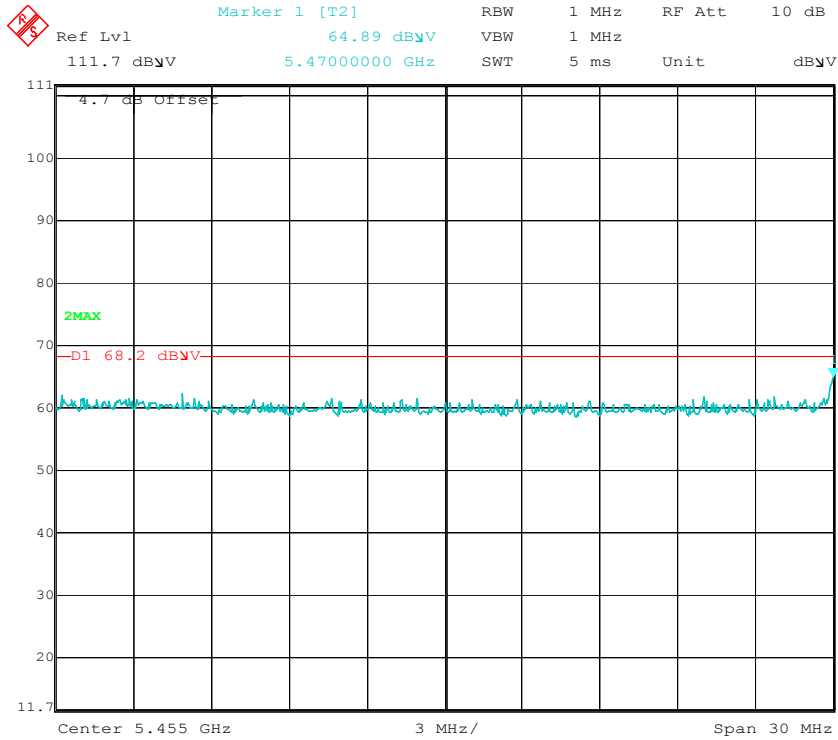

Low Channel (16MHz Mode 3)

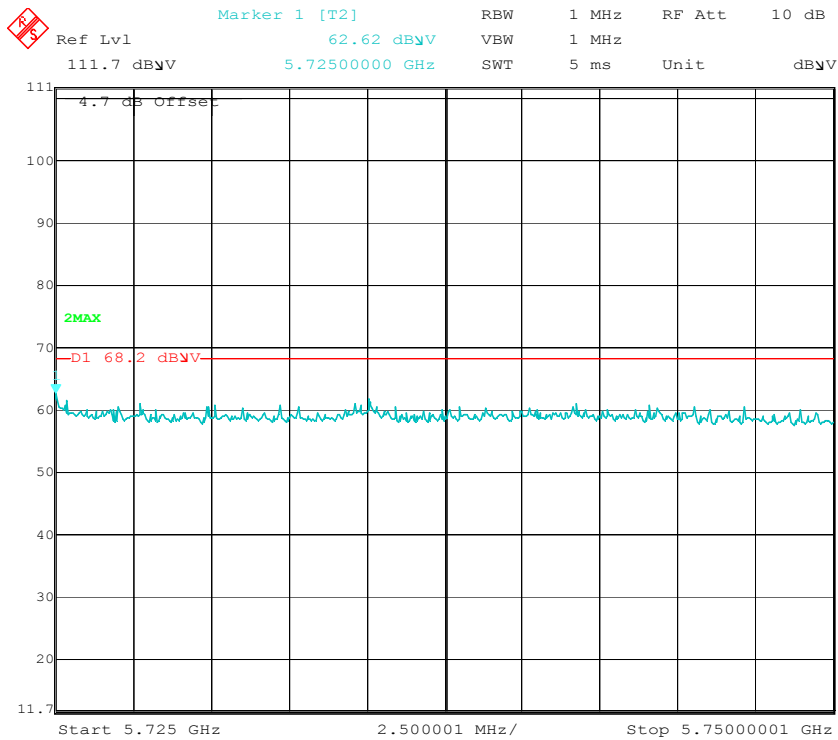

High Channel (16MHz Mode 1)

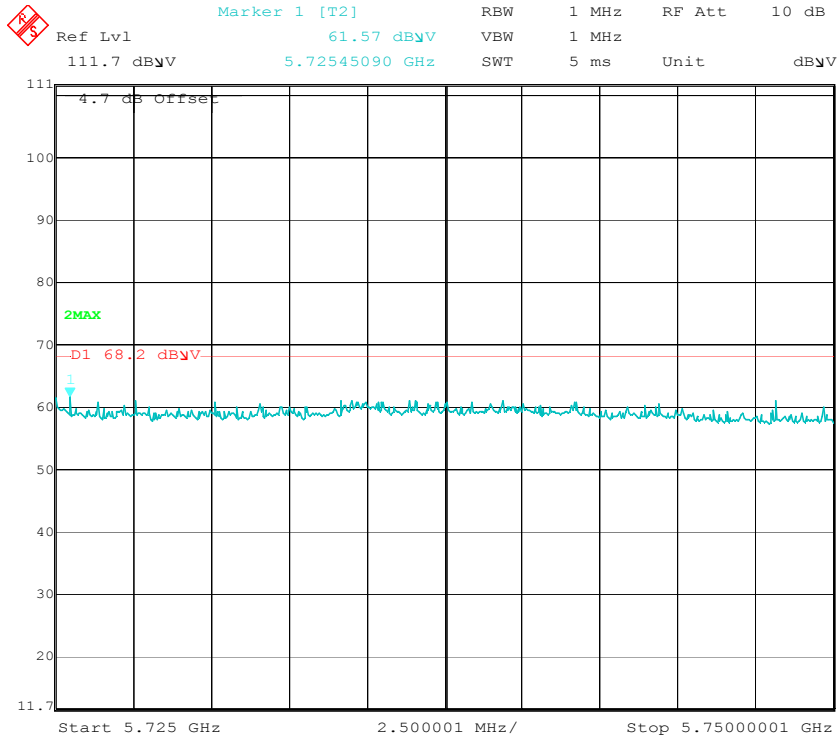

High Channel (16MHz Mode 2)

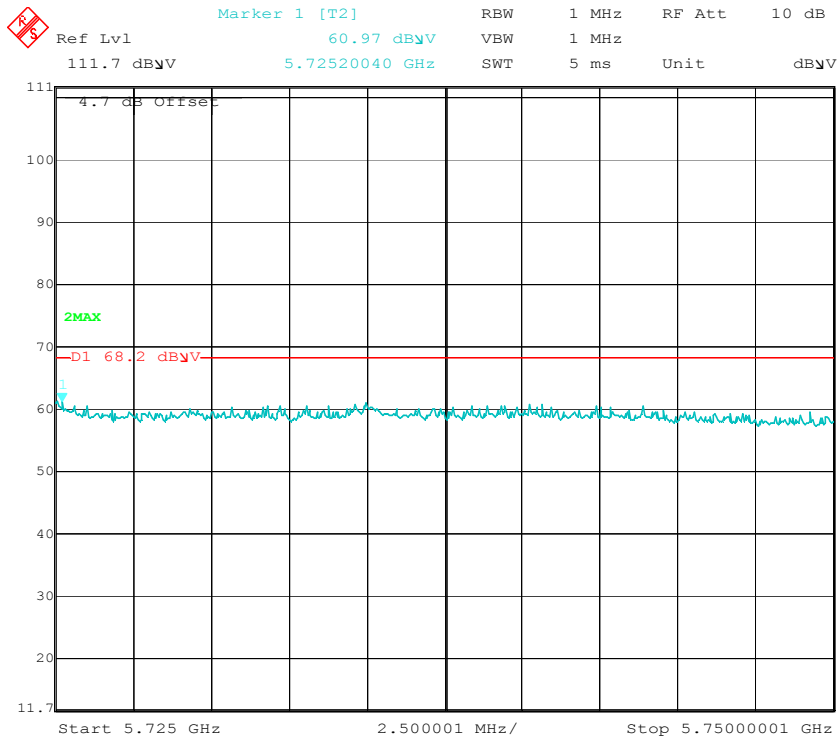

High Channel (16MHz Mode 3)

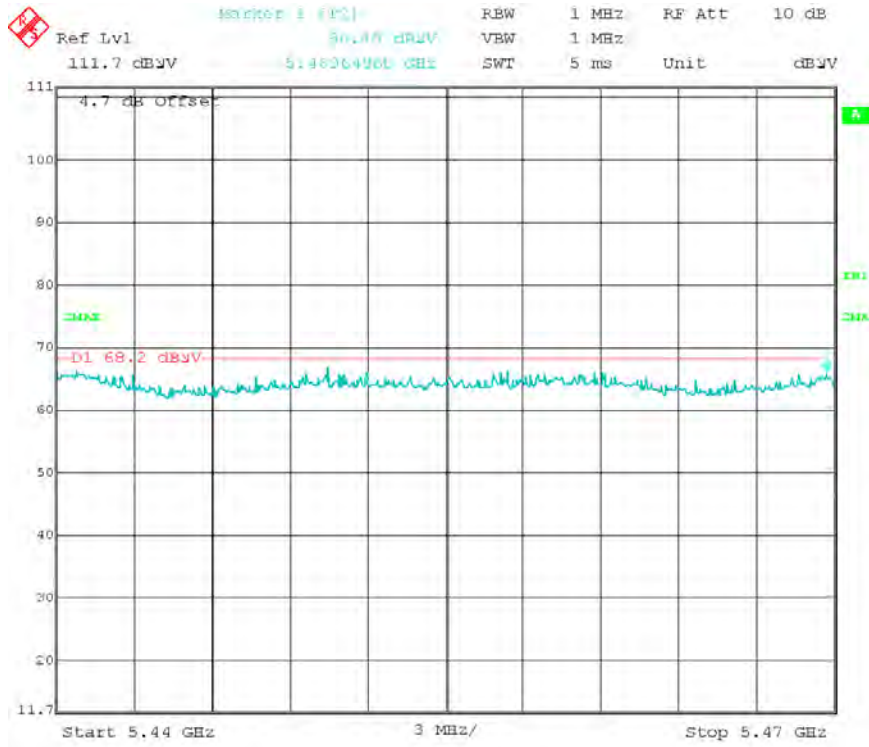

Low Channel (32MHz Mode 1)

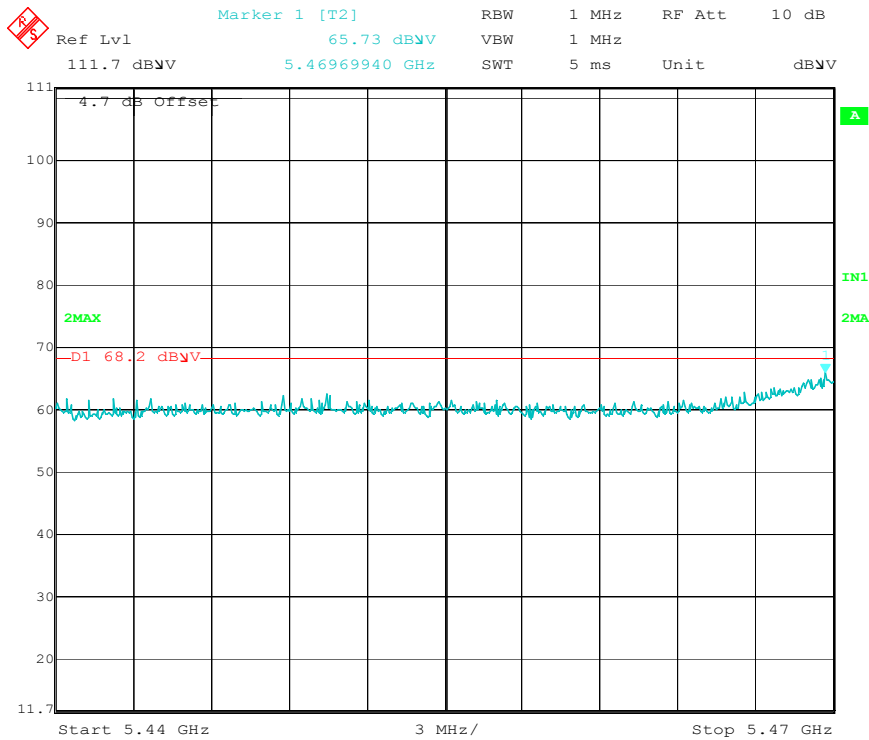

Low Channel (32MHz Mode 2)

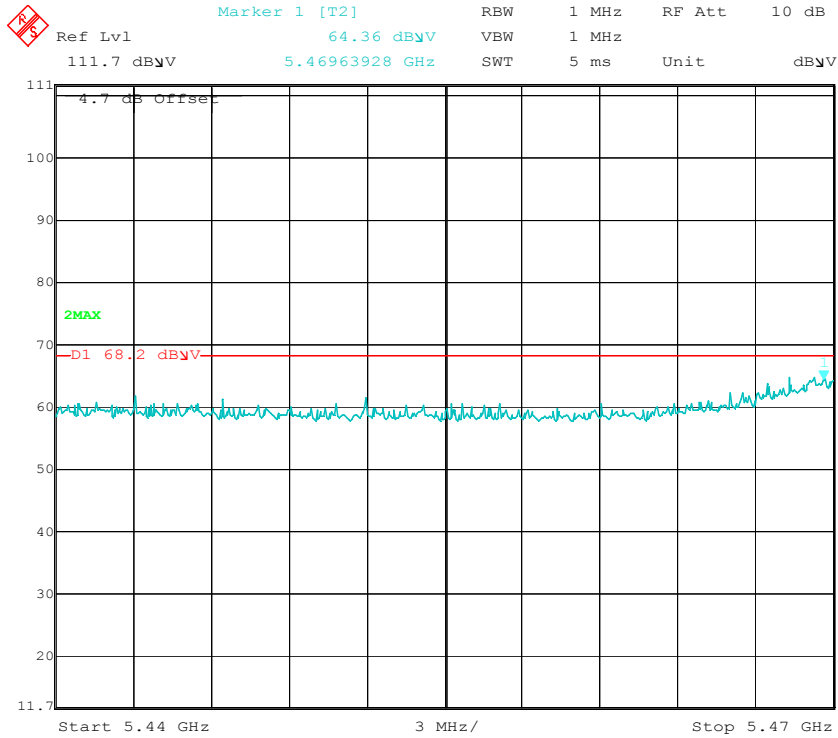

Low Channel (32MHz Mode 3)

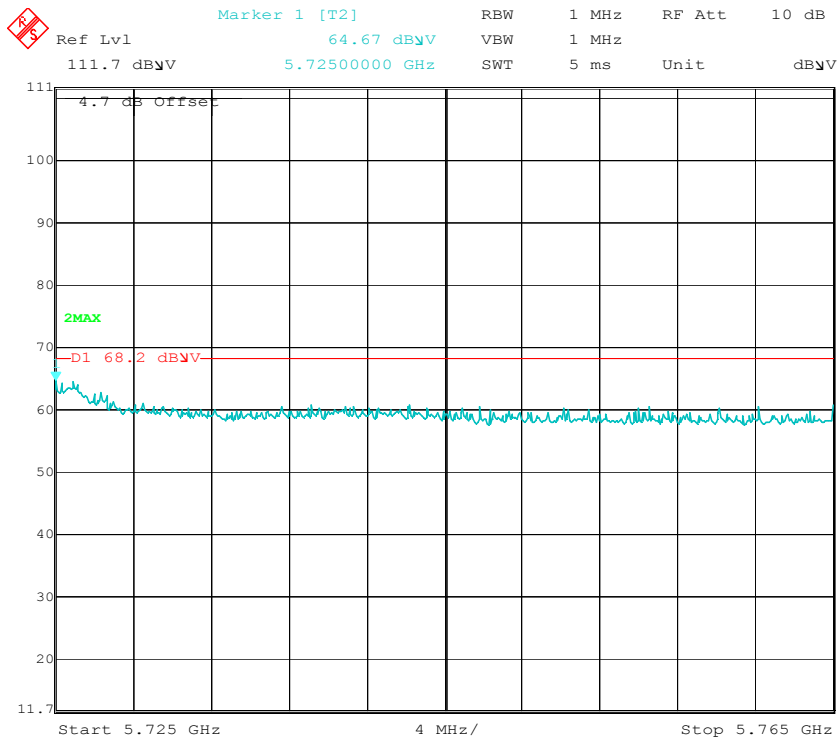

High Channel (32MHz Mode 1)

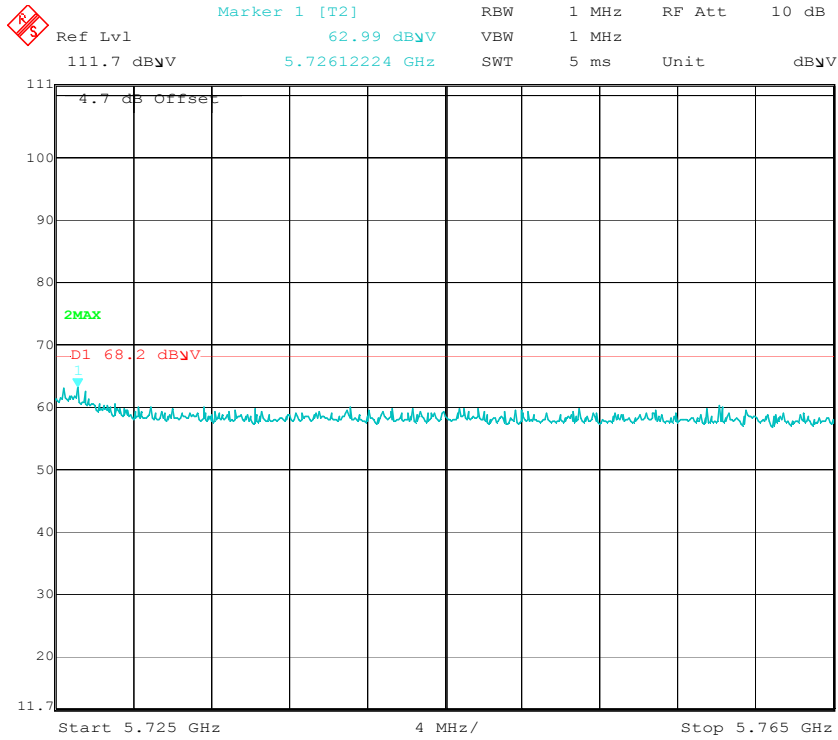

High Channel (32MHz Mode 2)

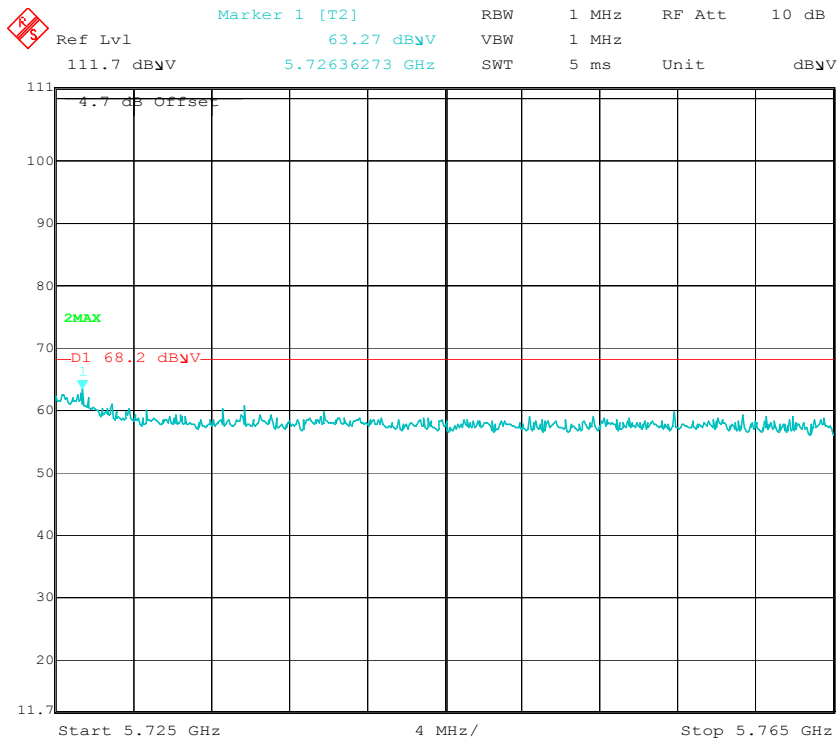

High Channel (32MHz Mode 3)

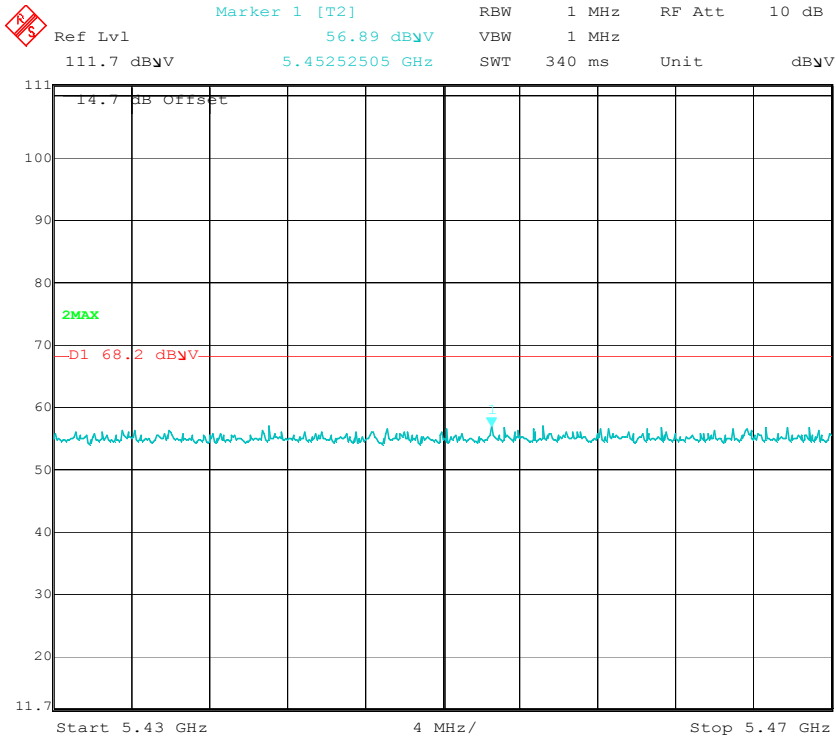

Low Channel (8MHz Mode 3)

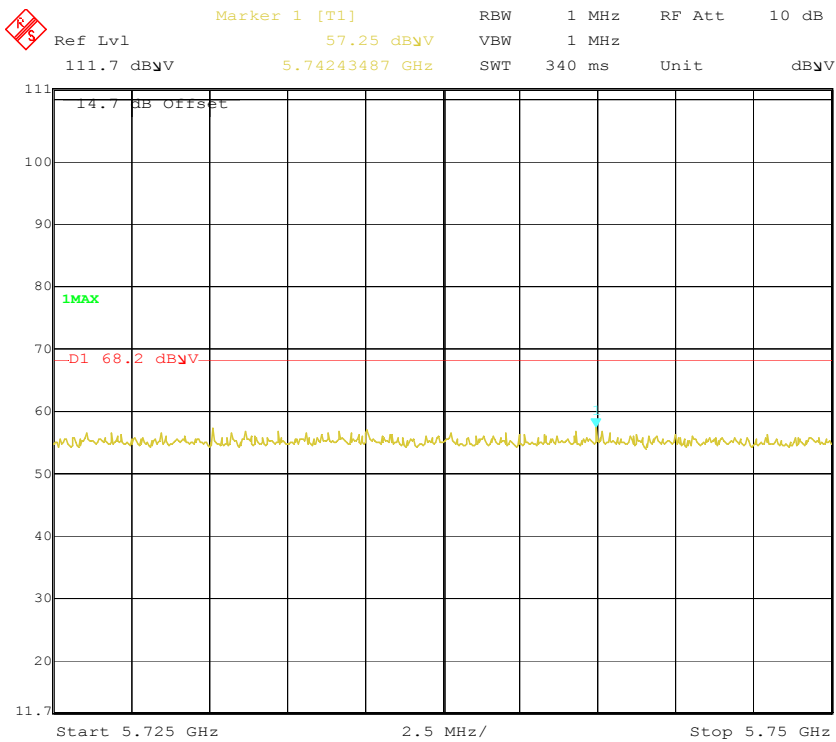

High Channel (8MHz Mode 1)

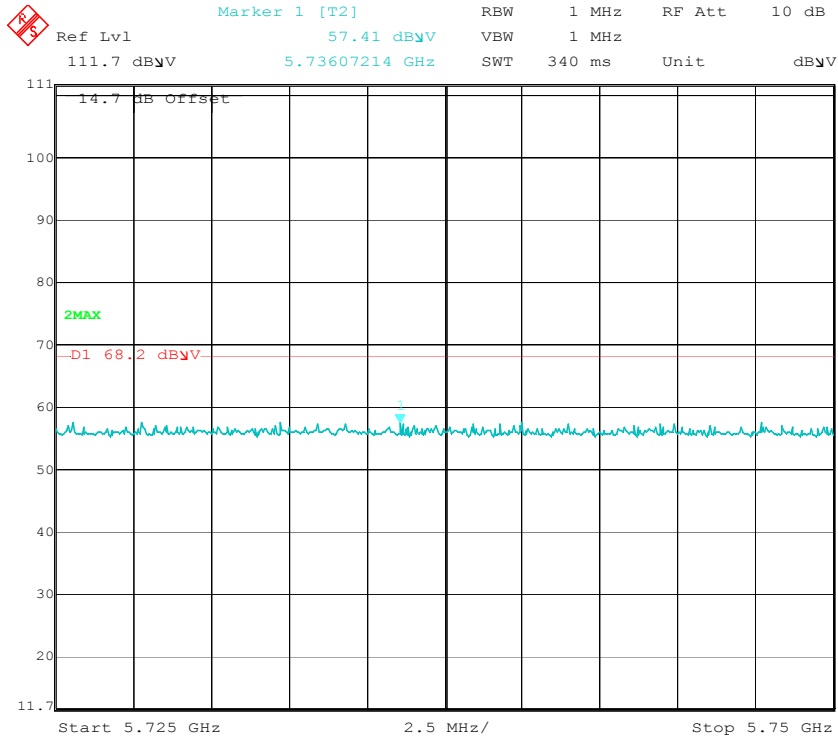

High Channel (8MHz Mode 2)

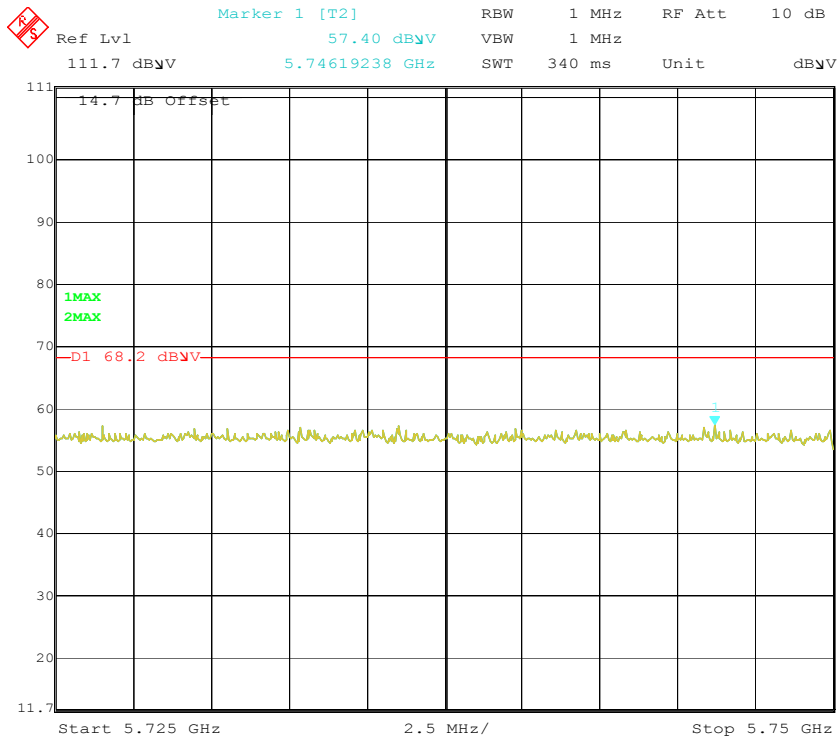

High Channel (8MHz Mode 3)

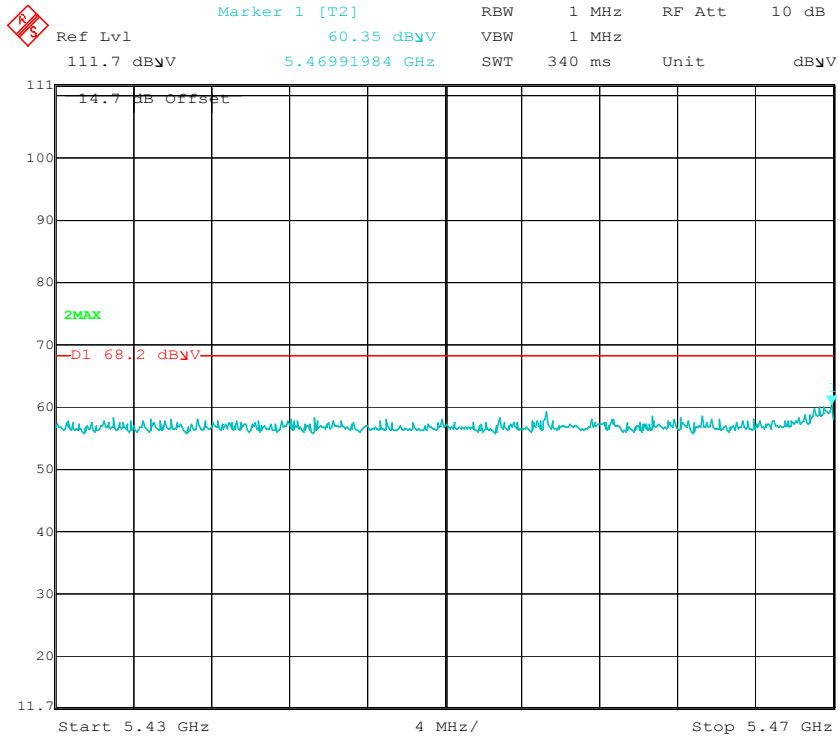

Low Channel (16MHz Mode 1)

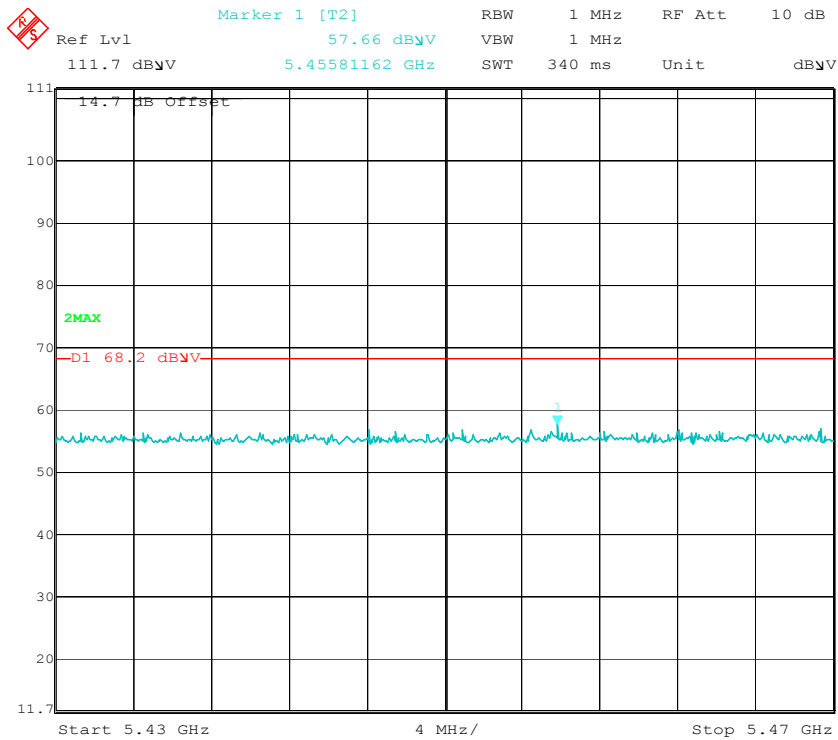

Low Channel (16MHz Mode 2)

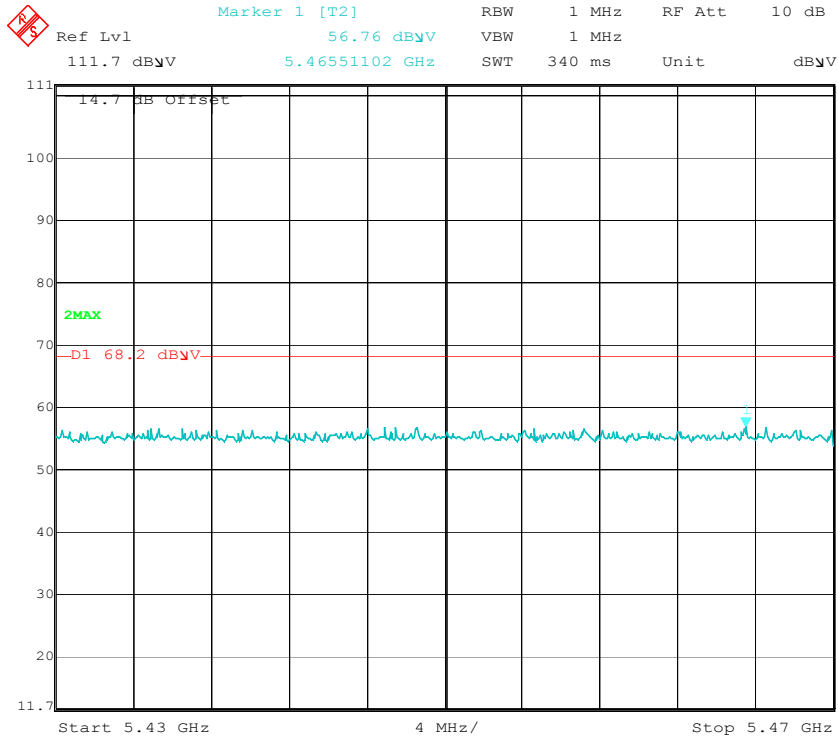

Low Channel (16MHz Mode 3)

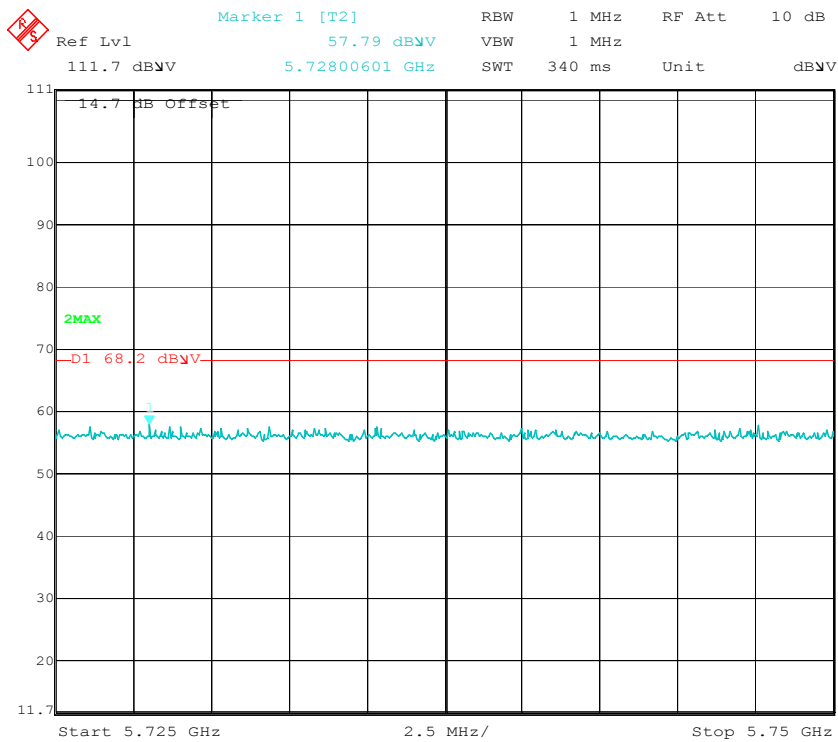

High Channel (16MHz Mode 1)

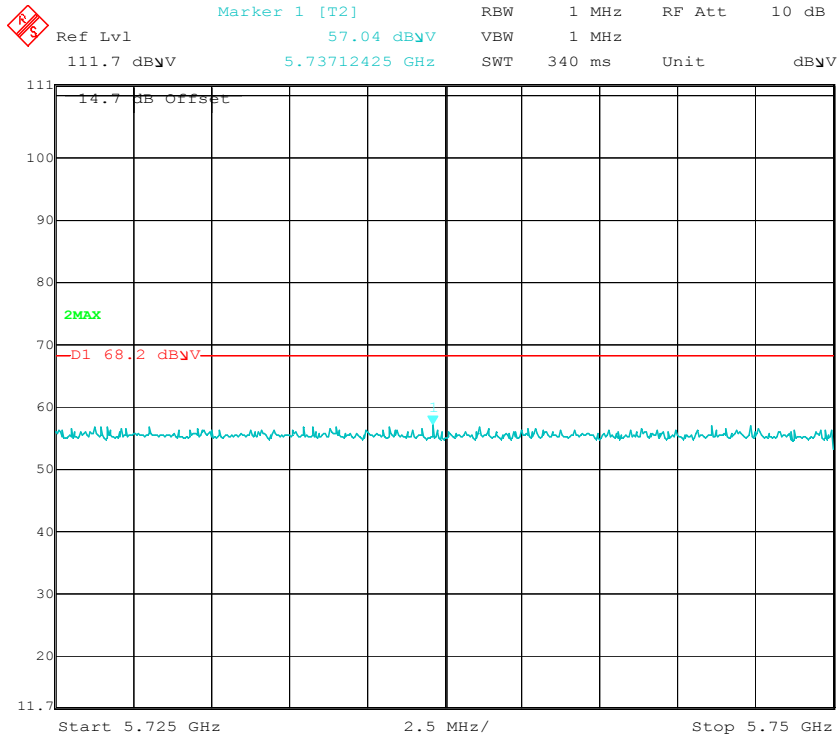

High Channel (16MHz Mode 2)

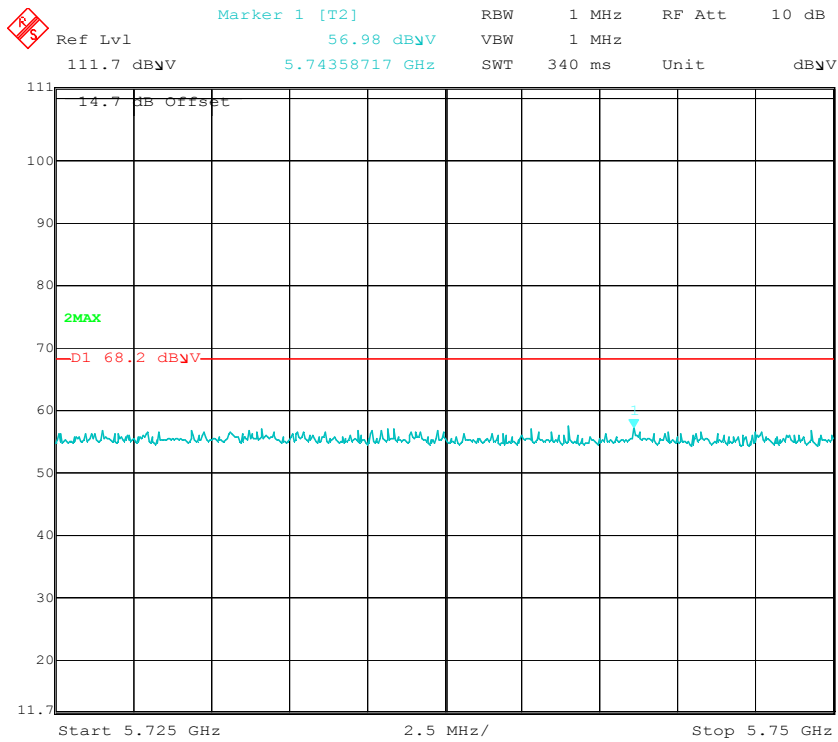

High Channel (16MHz Mode 3)

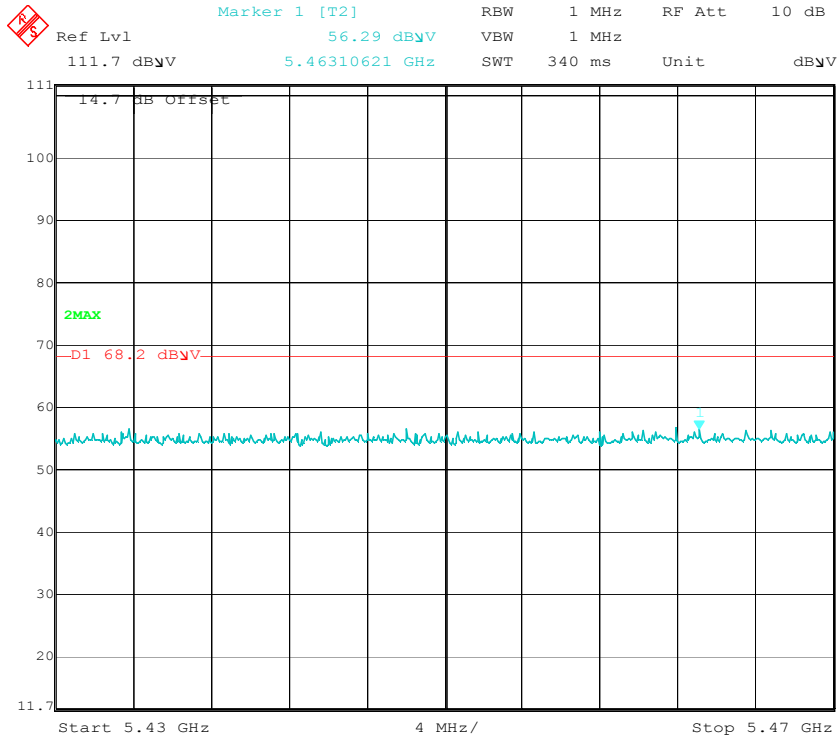

Low Channel (32MHz Mode 1)

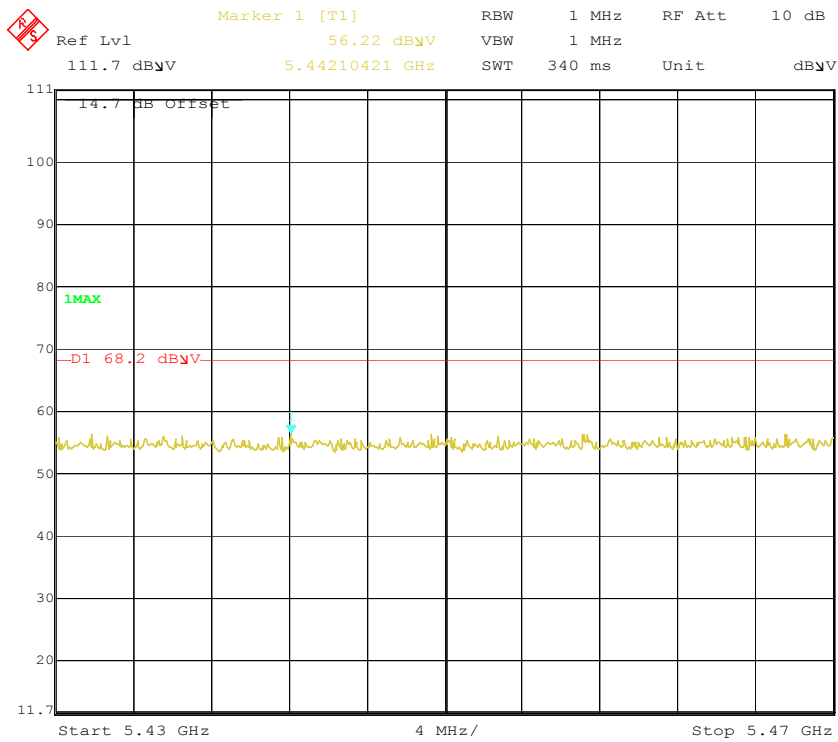

Low Channel (32MHz Mode 2)

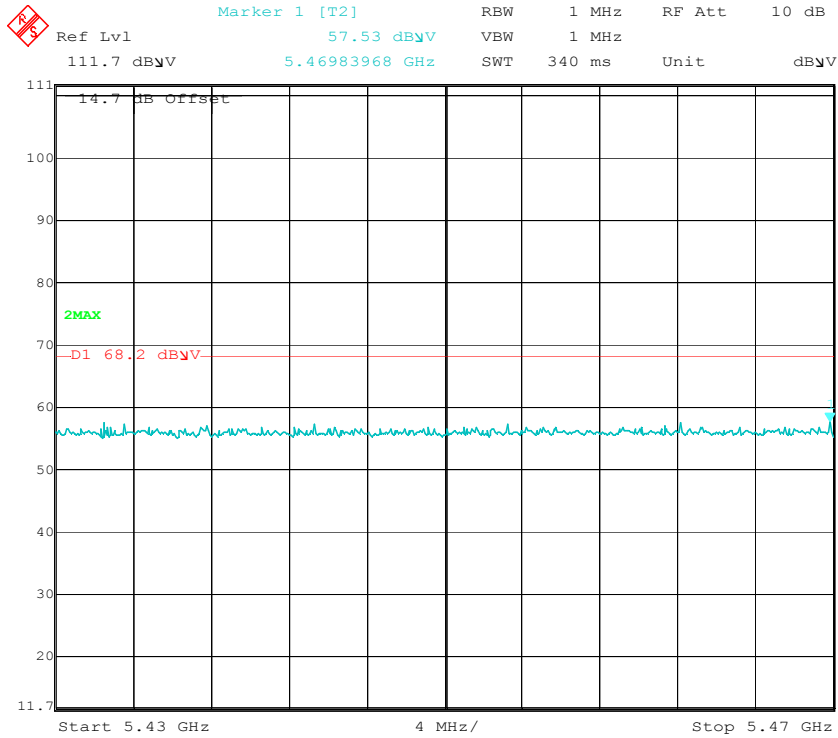

Low Channel (32MHz Mode 3)

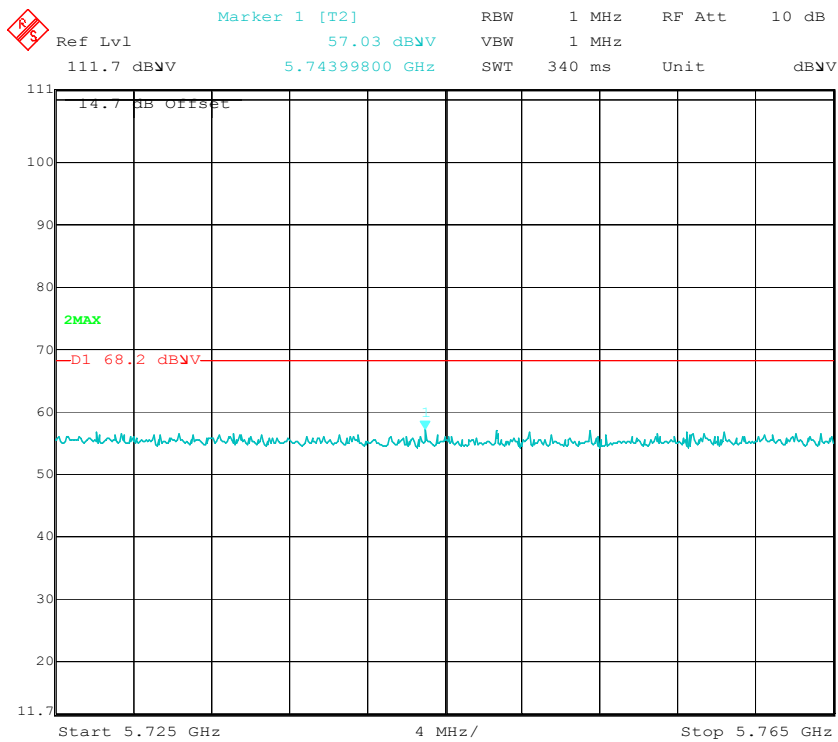

High Channel (32MHz Mode 1)

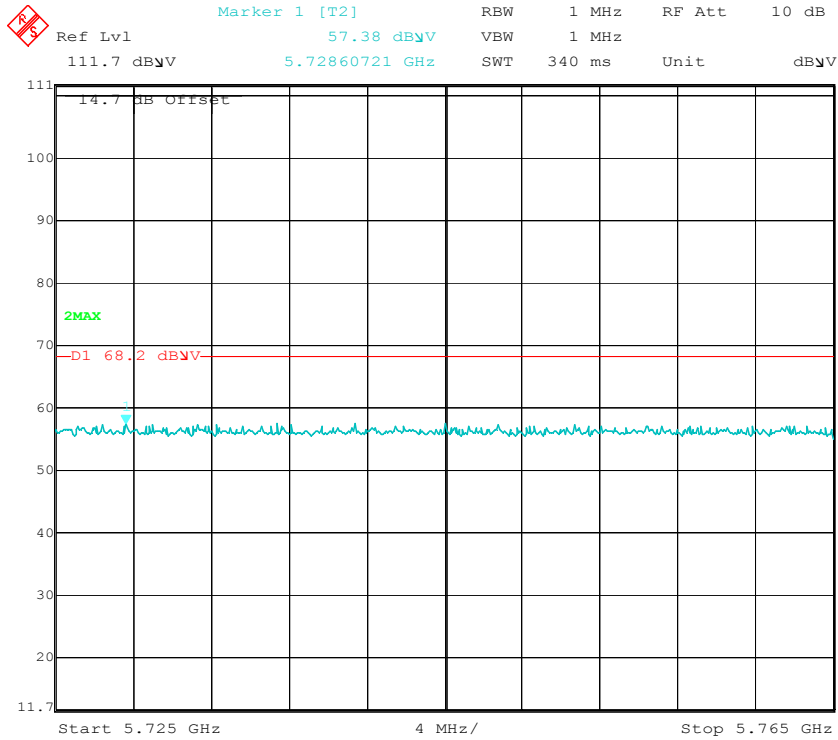

High Channel (32MHz Mode 2)

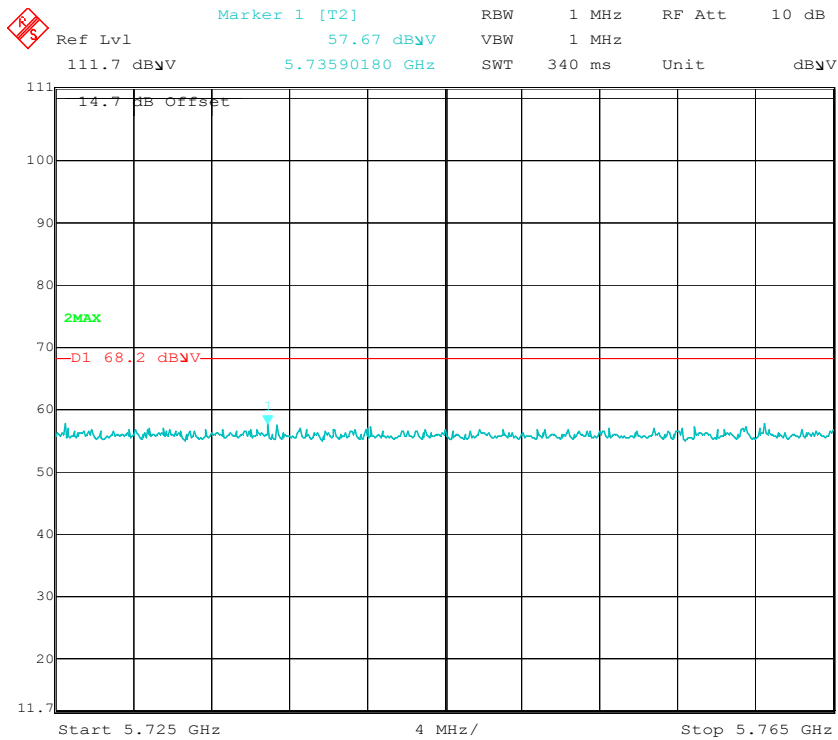

High Channel (32MHz Mode 3)

Horizontal Polarity

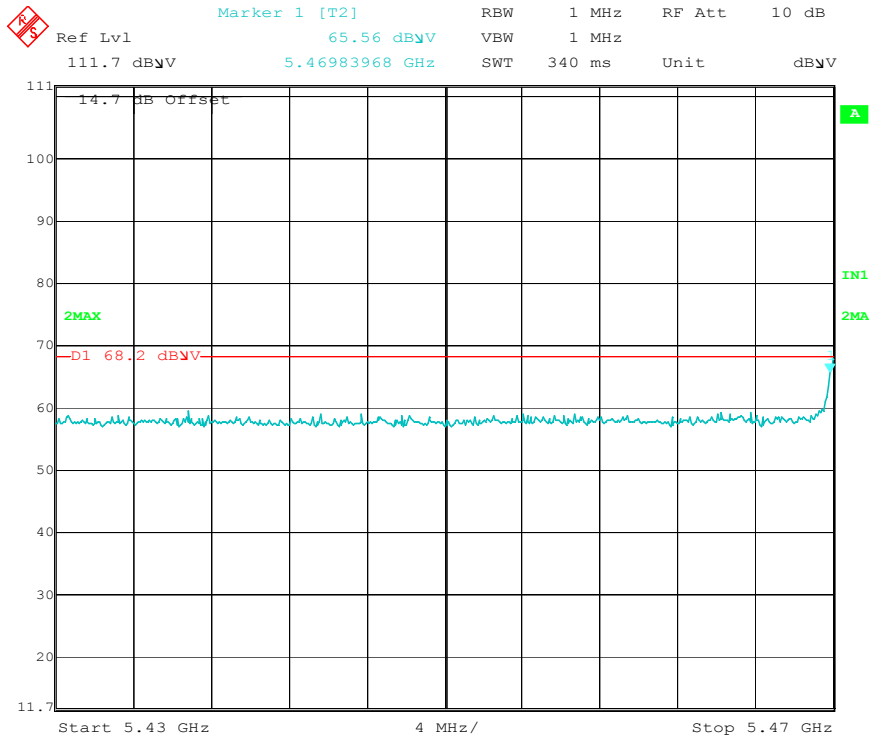

Low Channel (8MHz Mode 1)

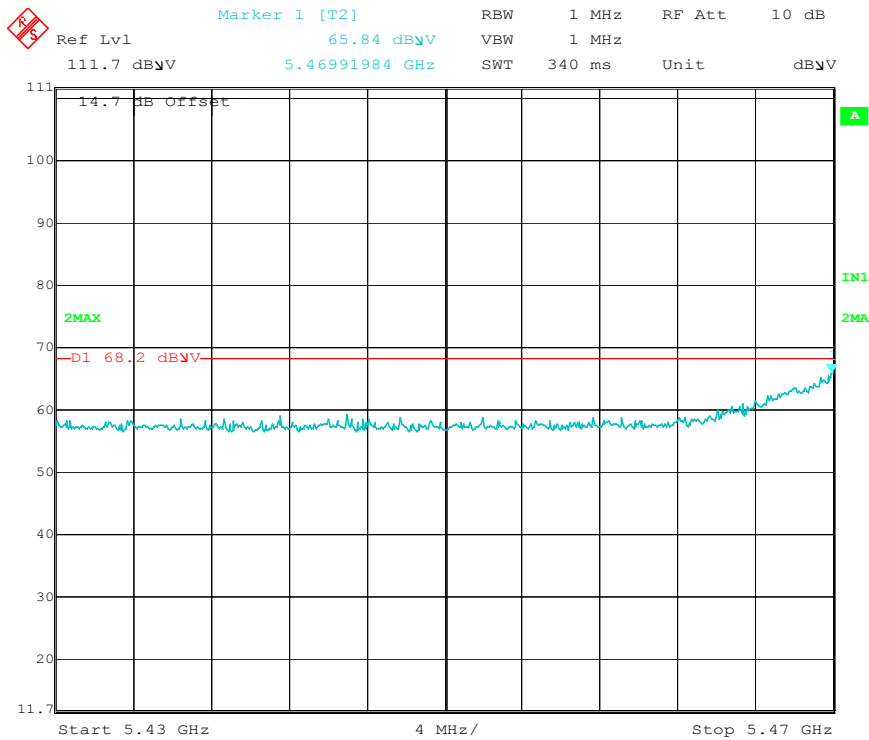

Low Channel (8MHz Mode 2)

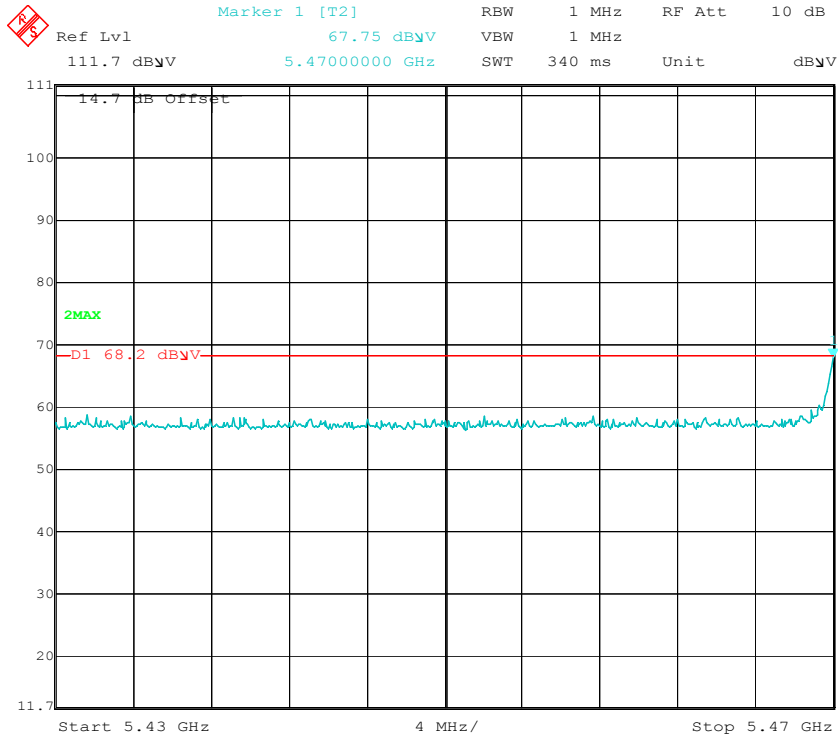

Low Channel (8MHz Mode 3)

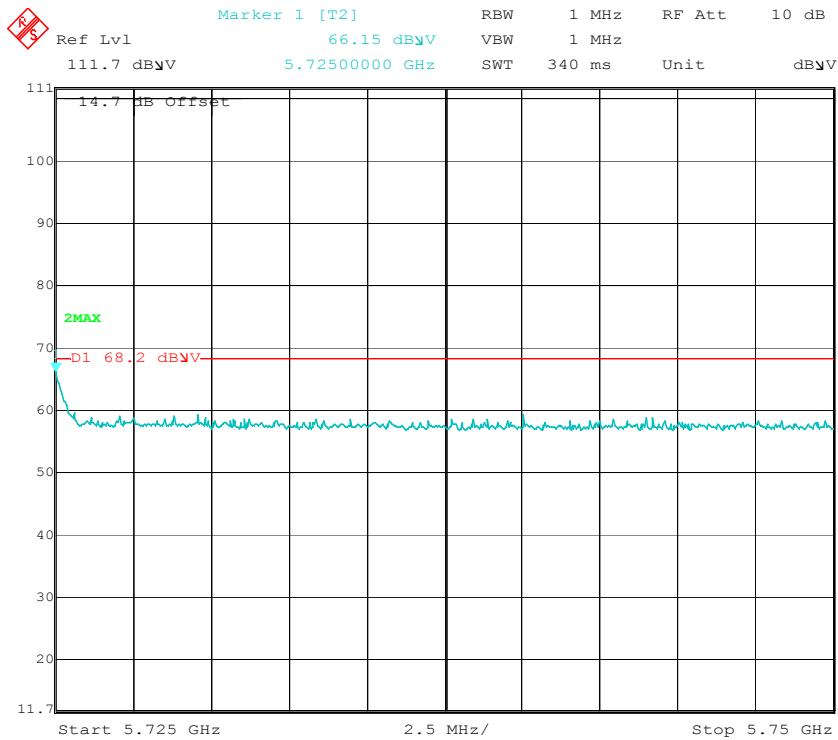

High Channel (8MHz Mode 1)

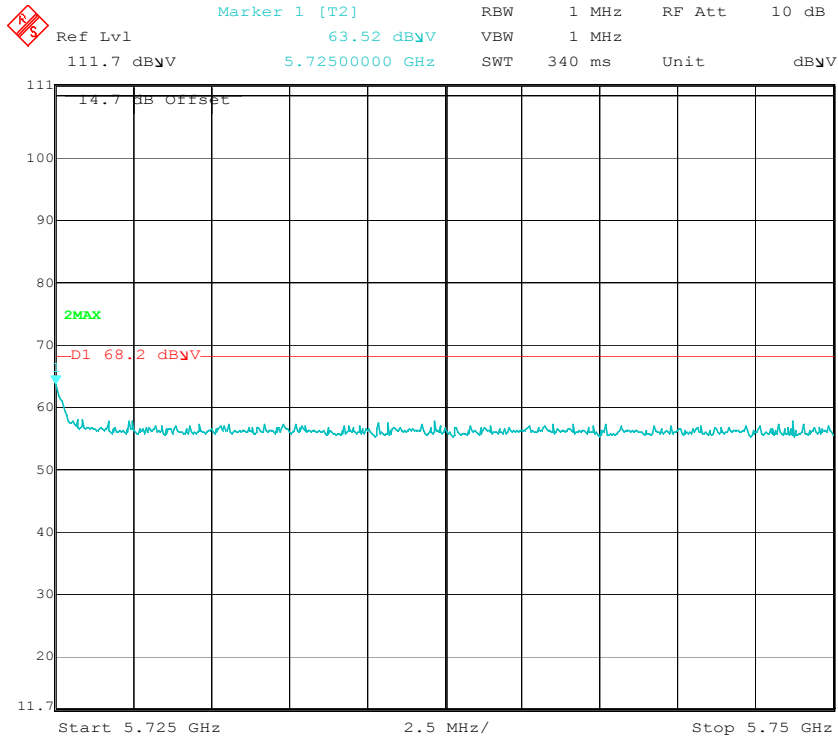

High Channel (8MHz Mode 2)

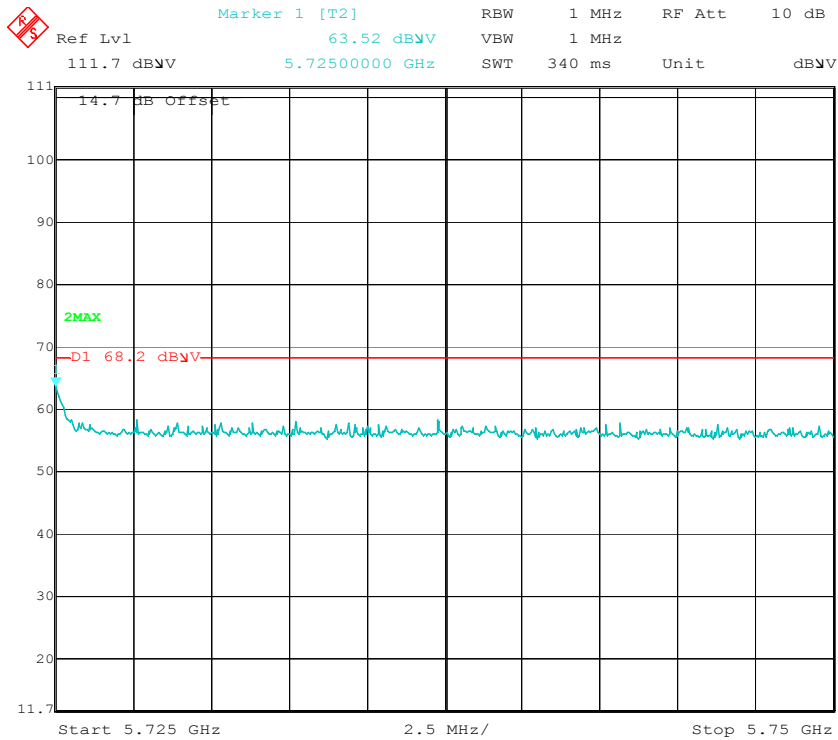

High Channel (8MHz Mode 3)

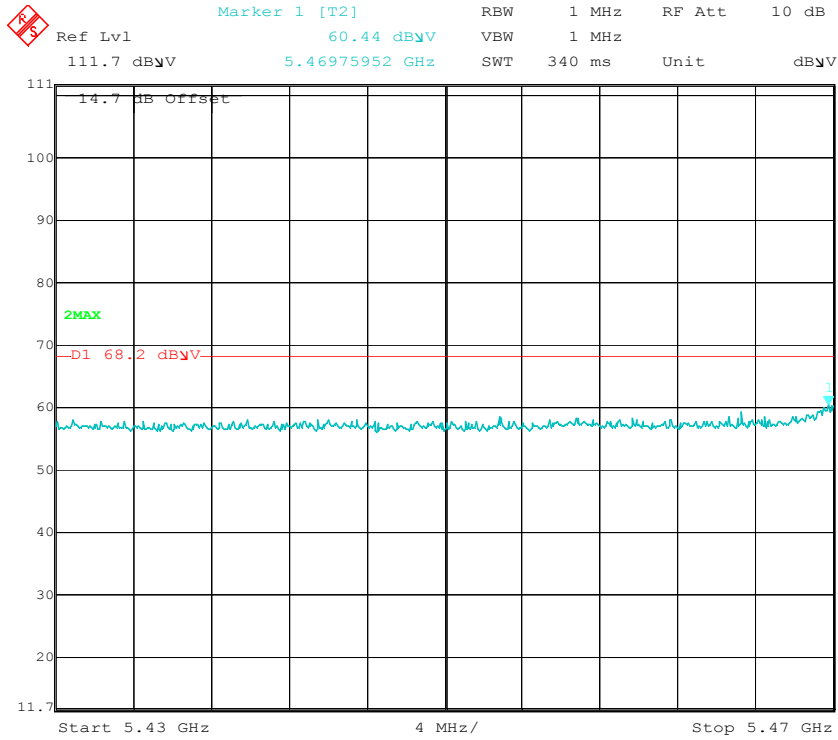

Low Channel (16MHz Mode 1)

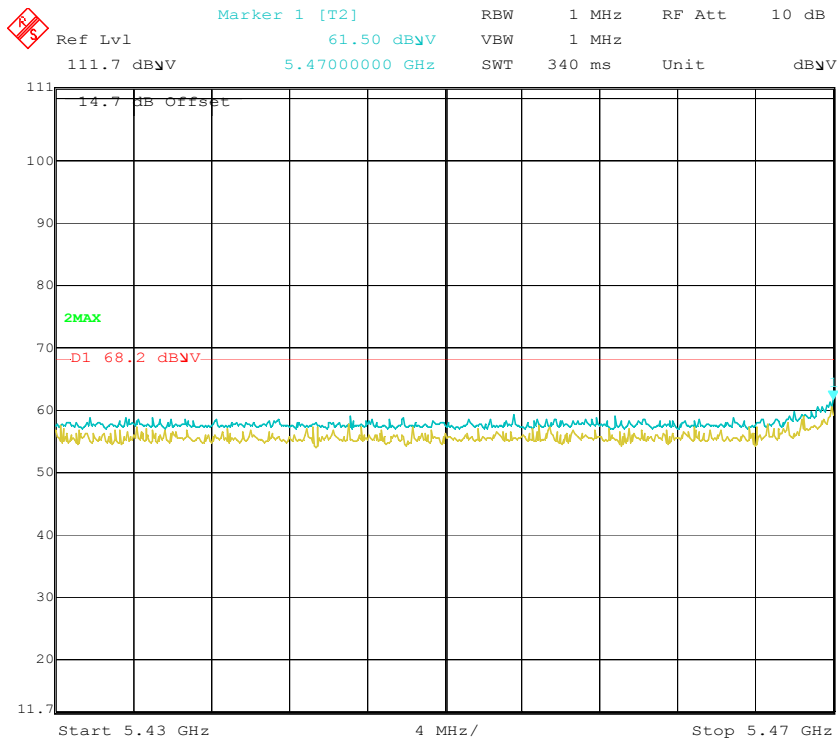

Low Channel (16MHz Mode 2)

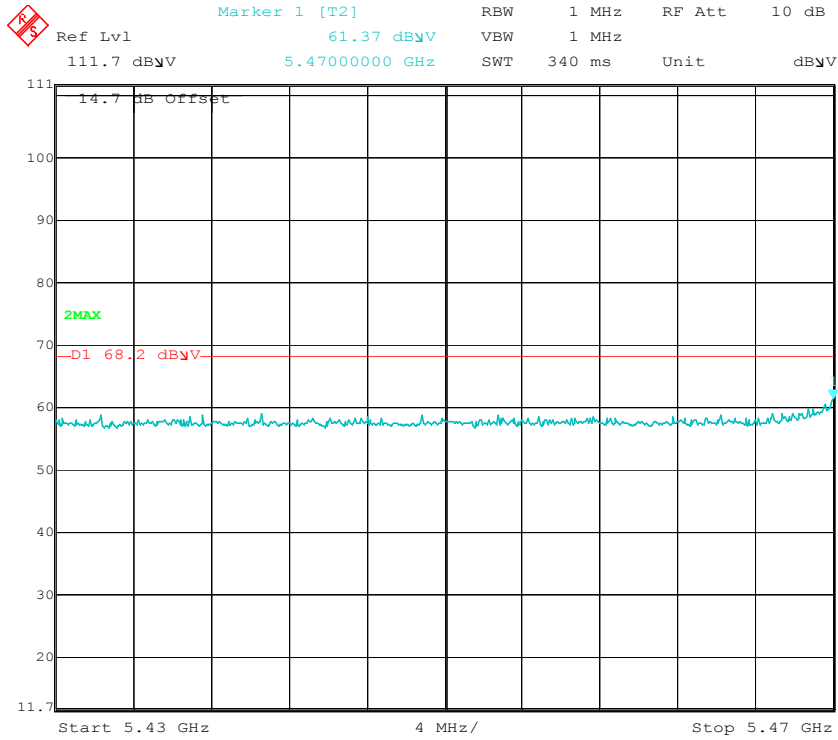

Low Channel (16MHz Mode 3)

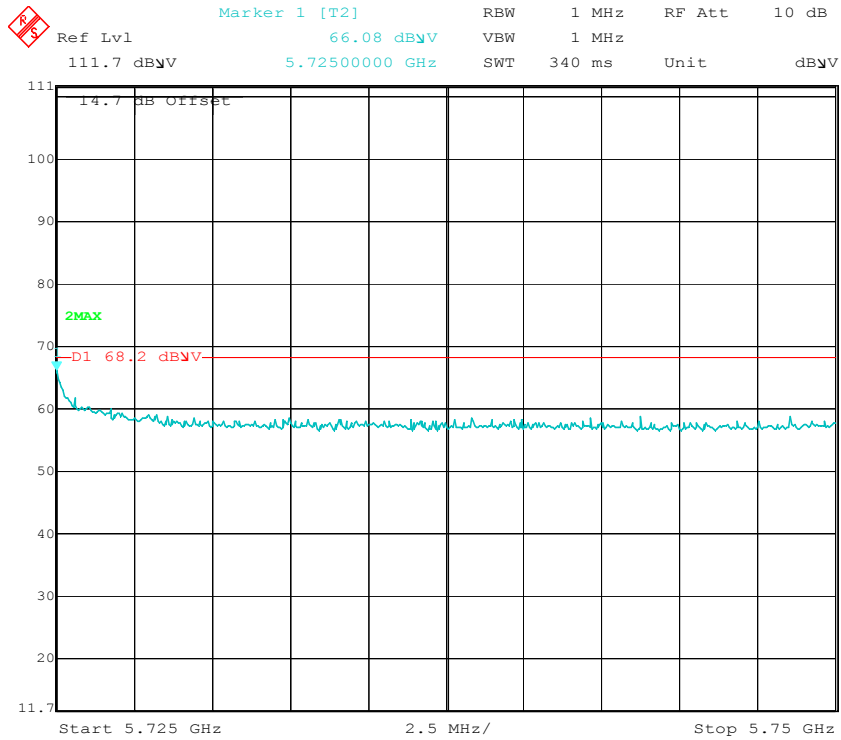

High Channel (16MHz Mode 1)

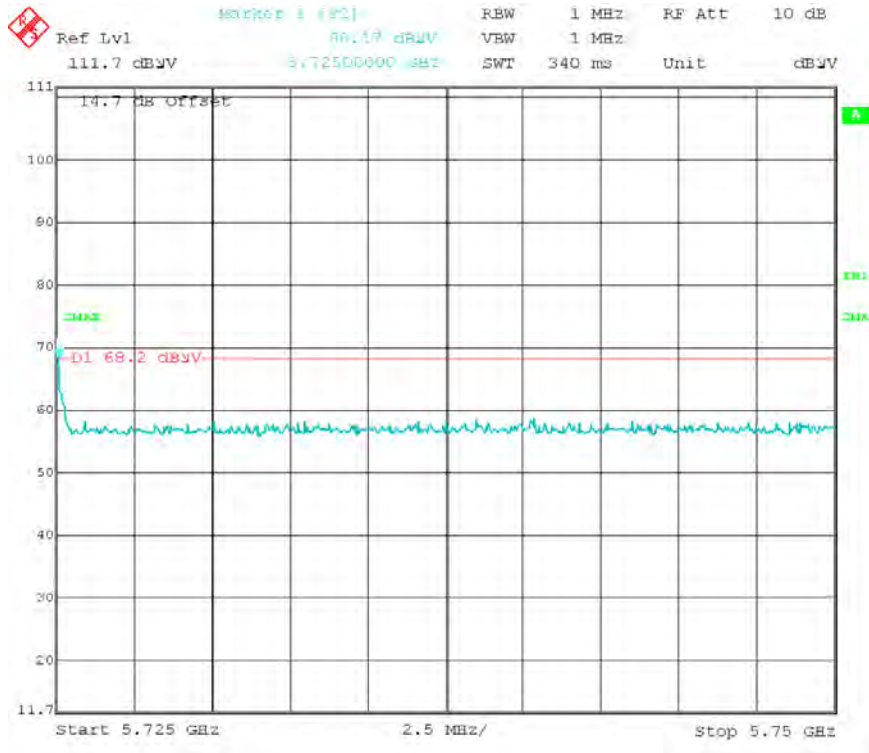

High Channel (16MHz Mode 2)

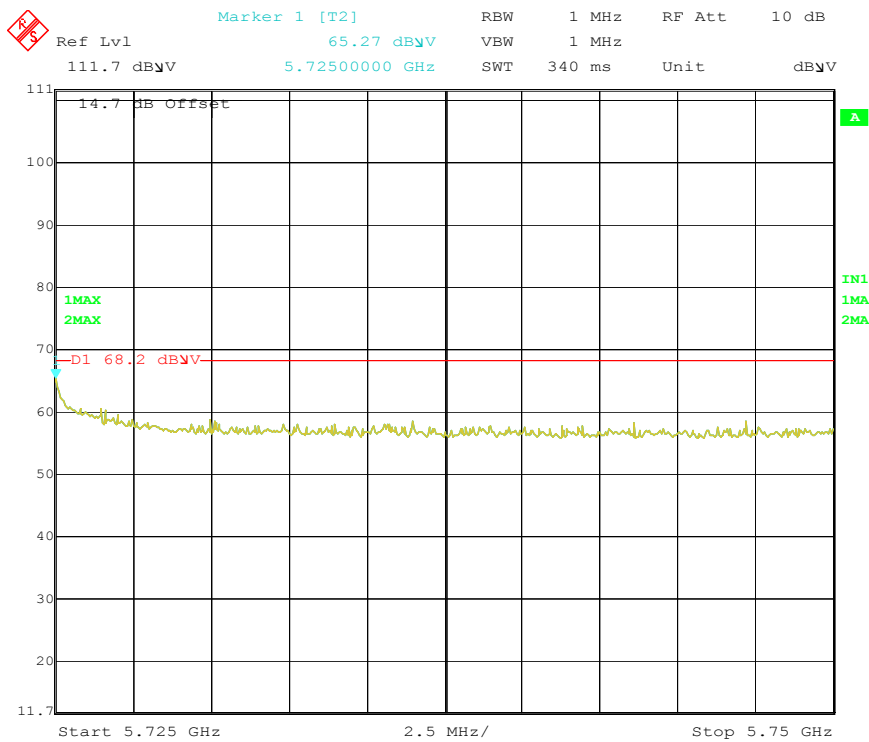

High Channel (16MHz Mode 3)

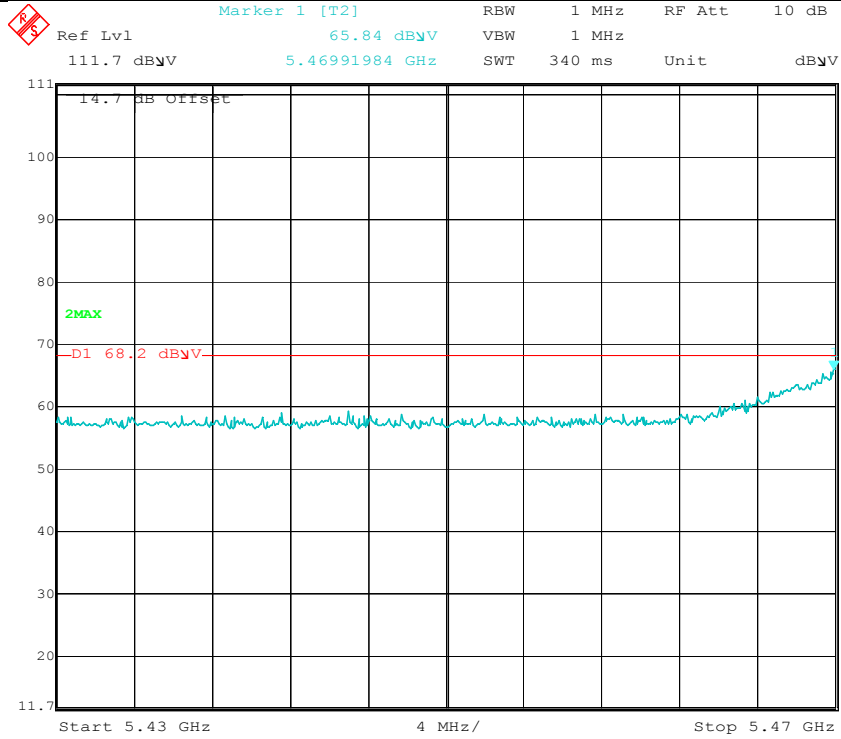

Low Channel (32MHz Mode 1)

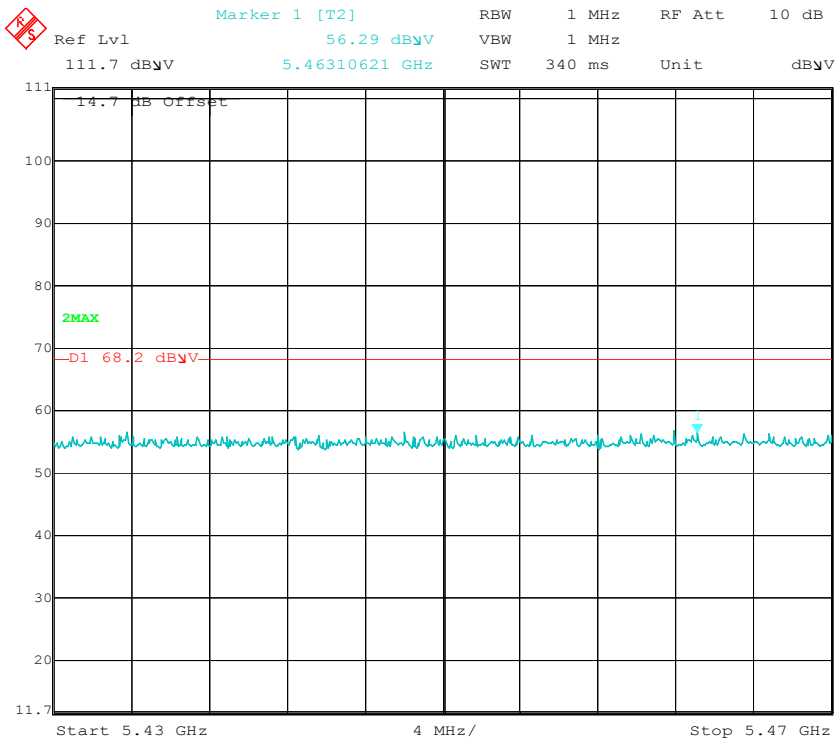

Low Channel (32MHz Mode 2)



 Marker 1 [T2] RBW 1 MHz RF Att 10 dB
Ref Lvl 64.71 dBV VBW 1 MHz
111.7 dBV 5.4700000 GHz SWT 340 ms Unit dBV

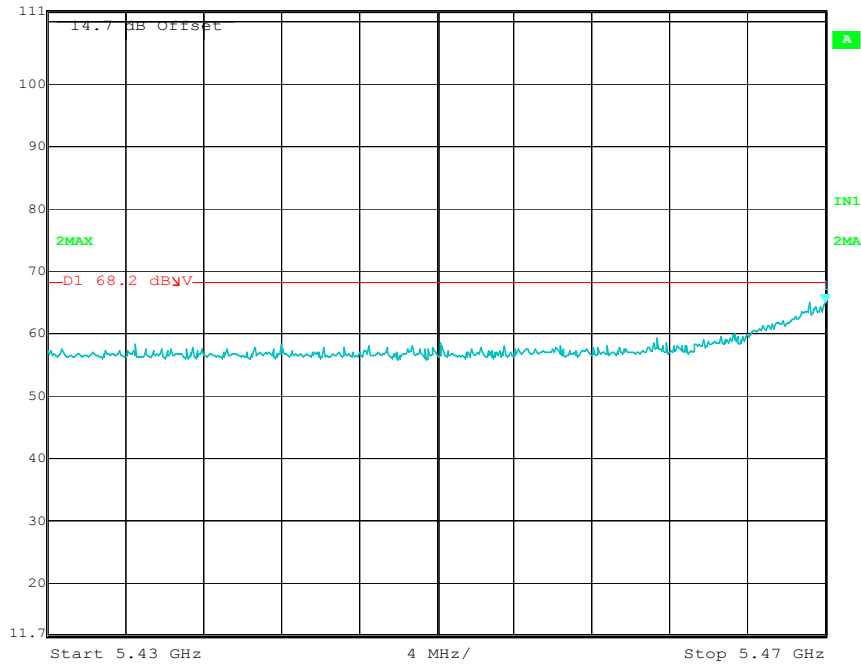

Low Channel (32MHz Mode 3)

 Marker 1 [T2] RBW 1 MHz RF Att 10 dB
Ref Lvl 60.44 dBV VBW 1 MHz
111.7 dBV 5.72548096 GHz SWT 340 ms Unit dBV

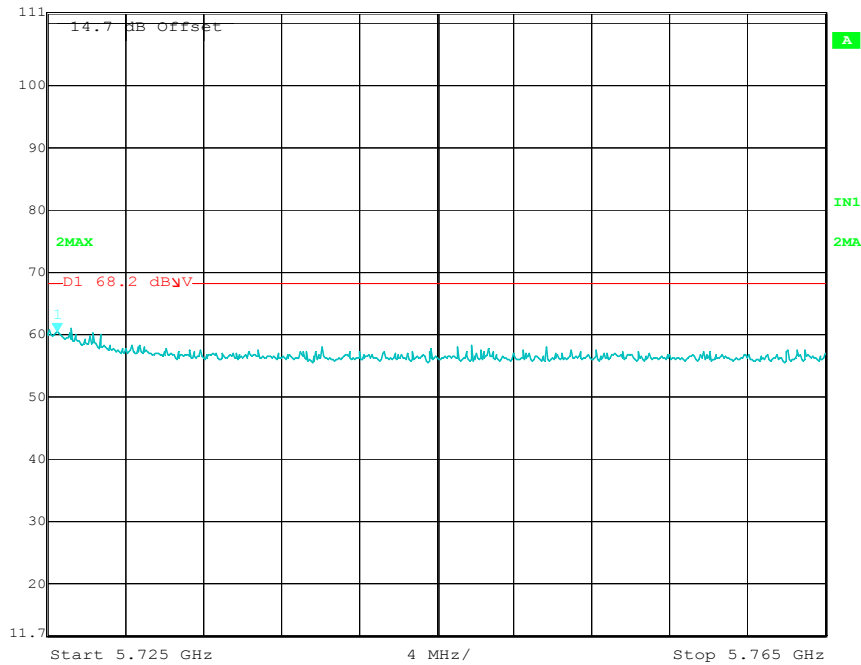

High Channel (32MHz Mode 1)

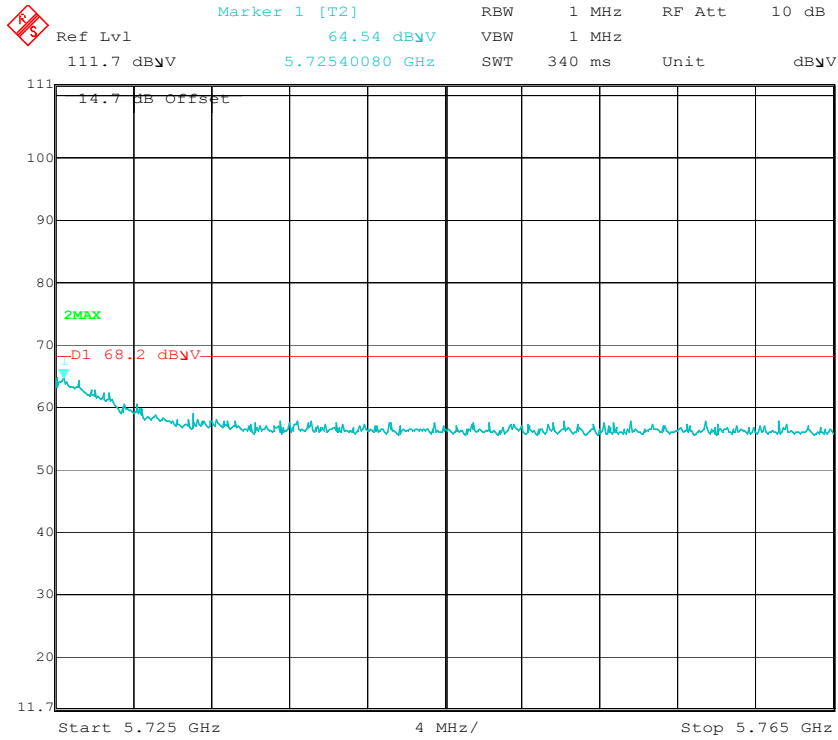

High Channel (32MHz Mode 2)

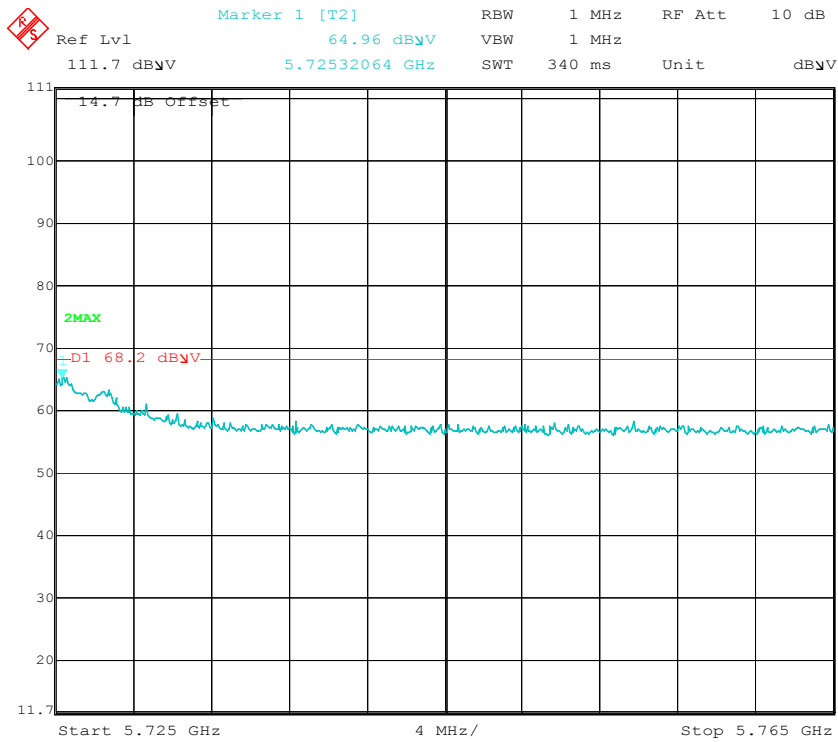

High Channel (32MHz Mode 3)

Annex A. TEST INSTRUMENT & METHOD

Annex A.i. TEST INSTRUMENTATION & GENERAL PROCEDURES

Instrument	Model	Serial #	Calibration Date	Calibration Due	Calibrate Cycle
CONDUCTED EMISSIONS					
R & S Receiver	ESIB 40	100179	4/20/2012	4/20/2013	1year
R&S LISN	ESH2-Z5	861741/013	05/18/2012	05/18/2013	1year
CHASE LISN	MN2050B	1018	05/18/2012	05/18/2013	1year
Sekonic Hygro Hermograph	ST-50	HE01-000092	05/25/2012	05/25/2013	1year
Radiated Emissions					
R & S Receiver	ESIB 40	100179	4/20/2012	4/20/2013	1year
Sunol Sciences, Inc. antenna (30MHz~2GHz)	JB1	A030702	2/9/2012	2/9/2013	1year
3 Meters SAC	3M	N/A	10/13/2011	10/13/2012	1year
Sekonic Hygro Hermograph	ST-50	HE01-000092	05/25/2012	05/25/2013	1year
Spectrum Analyzer	8564E	3738A00962	05/19/2012	05/19/2013	1year
Antenna(1 ~18GHz)	3115	10SL0059	4/26/2012	4/26/2013	1year
Pre-Amplifier(1 ~ 26GHz)	8449	3008A00715	5/17/2012	5/17/2013	1year
Horn Antenna (18~40GHz)	AH-840	101013	4/23/2012	4/23/2013	1year
Microwave Preamplifier; 18-40 GHz	PA-840	181251	N/A	N/A	Every 2000hours
Signal Analyzer	FSIQ7	825555/013	5/10/2012	5/10/2013	1year

Note: No calibration required.

Annex A.ii. CONDUCTED EMISSIONS TEST DESCRIPTION

Test Set-up

1. The EUT and supporting equipment were set up in accordance with the requirements of the standard on top of a 1.5m x 1m x 0.8m high, non-metallic table, as shown in Annex B.
2. The power supply for the EUT was fed through a 50Ω/50μH EUT LISN, connected to filtered mains.
3. The RF OUT of the EUT LISN was connected to the EMI test receiver via a low-loss coaxial cable.
4. All other supporting equipments were powered separately from another main supply.

Test Method

1. The EUT was switched on and allowed to warm up to its normal operating condition.
2. A scan was made on the NEUTRAL line (for AC mains) or Earth line (for DC power) over the required frequency range using an EMI test receiver.
3. High peaks, relative to the limit line, were then selected.
4. The EMI test receiver was then tuned to the selected frequencies and the necessary measurements made with a receiver bandwidth setting of 10 KHz. For FCC tests, only Quasi-peak measurements were made; while for CISPR/EN tests, both Quasi-peak and Average measurements were made.
5. Steps 2 to 4 were then repeated for the LIVE line (for AC mains) or DC line (for DC power).

Sample Calculation Example

At 20 MHz	limit = 250 μV = 47.96 dBμV
Transducer factor of LISN, pulse limiter & cable loss at 20 MHz = 11.20 dB	
Q-P reading obtained directly from EMI Receiver = 40.00 dBμV	
(Calibrated for system losses)	
Therefore, Q-P margin = 47.96 – 40.00 = 7.96	i.e. 7.96 dB below limit

Annex A. iii RADIATED EMISSIONS TEST DESCRIPTION

EUT Characterisation

EUT characterisation, over the frequency range from 30MHz to 10th Harmonic , was done in order to minimise radiated emissions testing time while still maintaining high confidence in the test results.

The EUT was placed in the chamber, at a height of about 0.8m on a turntable. Its radiated emissions frequency profile was observed, using a spectrum analyzer /receiver with the appropriate broadband antenna placed 3m away from the EUT. Radiated emissions from the EUT were maximised by rotating the turntable manually, changing the antenna polarisation and manipulating the EUT cables while observing the frequency profile on the spectrum analyzer / receiver. Frequency points at which maximum emissions occurred, clock frequencies and operating frequencies were then noted for the formal radiated emissions test at the Open Area Test Site (OATS).

Test Set-up

1. The EUT and supporting equipment were set up in accordance with the requirements of the standard on top of a 1.5m X 1.0m X 0.8m high, non-metallic table.
2. The filtered power supply for the EUT and supporting equipment were tapped from the appropriate power sockets located on the turntable.
3. The relevant broadband antenna was set at the required test distance away from the EUT and supporting equipment boundary.

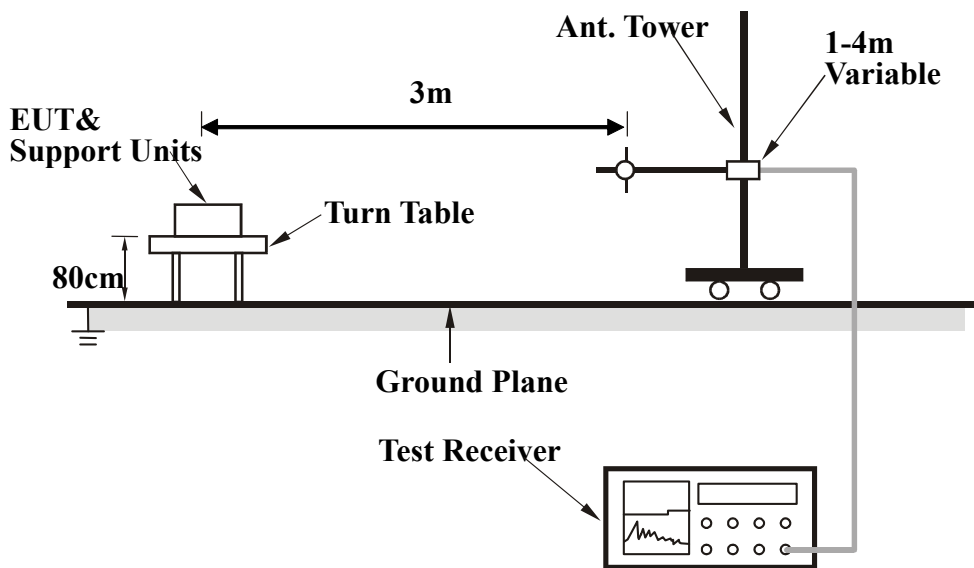

Test Method

The following procedure was performed to determine the maximum emission axis of EUT:

1. With the receiving antenna is H polarization, rotate the EUT in turns with three orthogonal axes to determine the axis of maximum emission.
2. With the receiving antenna is V polarization, rotate the EUT in turns with three orthogonal axes to determine the axis of maximum emission.
3. Compare the results derived from above two steps. So, the axis of maximum emission from EUT was determined and the configuration was used to perform the final measurement.

Final Radiated Emission Measurement

1. Setup the configuration according to figure 1. Turn on EUT and make sure that it is in normal function.
2. For emission frequencies measured below 1 GHz, a pre-scan is performed in a shielded chamber to determine the accurate frequencies of higher emissions will be checked on a open test site. As the same purpose, for emission frequencies measured above 1 GHz, a pre-scan also be performed with a 1 meter measuring distance before final test.
3. For emission frequencies measured below and above 1 GHz, set the spectrum analyzer on a 100 kHz and 1 MHz resolution bandwidth respectively for each frequency measured in step 2.
4. The search antenna is to be raised and lowered over a range from 1 to 4 meters in horizontally polarized orientation. Position the highness when the highest value is indicated on spectrum analyzer, then change the orientation of EUT on test table over a range from 0 ° to 360 ° with a speed as slow as possible, and keep the azimuth that highest emission is indicated on the spectrum analyzer. Vary the antenna position again and record the highest value as a final reading.
5. Repeat step 4 until all frequencies need to be measured were complete.
6. Repeat step 5 with search antenna in vertical polarized orientations.

During the radiated emission test, the Spectrum Analyzer was set with the following configurations:

Frequency Band (MHz)	Function	Resolution bandwidth	Video Bandwidth
30 to 1000	Peak	100 kHz	100 kHz
Above 1000	Peak	1 MHz	1 MHz
	Average	1 MHz	10 Hz

Sample Calculation Example

The field strength is calculated by adding the Antenna Factor and Cable Factor, and subtracting the Amplifier Gain (if any) from the measured reading. For the limit is employed average value, therefore the peak value can be transferred to average value by subtracting the duty factor. The basic equation with a sample calculation is as follows:

$$\text{Peak} = \text{Reading} + \text{Corrected Factor}$$

where

$$\text{Corr. Factor} = \text{Antenna Factor} + \text{Cable Factor} - \text{Amplifier Gain (if any)}$$

And the average value is

$$\text{Average} = \text{Peak Value} + \text{Duty Factor or}$$

$$\text{Set RBW} = 1\text{MHz, VBW} = 10\text{Hz.}$$

Note :

If the measured frequencies are fall in the restricted frequency band, the limit employed must be quasi peak value when frequencies are below or equal to 1 GHz. And the measuring instrument is set to quasi peak detector function.

Annex B EUT AND TEST SETUP PHOTOGRAPHS

Please see the attachment

Annex C. TEST SETUP AND SUPPORTING EQUIPMENT

EUT TEST CONDITIONS

Annex C. i. SUPPORTING EQUIPMENT DESCRIPTION

The following is a description of supporting equipment and details of cables used with the EUT.

Equipment Description (Including Brand Name)	Model & Serial Number	Cable Description (List Length, Type & Purpose)
N/A	N/A	N/A

Remarks: The device does not have any supporting equipment, but it is controlled by itself when performing the compliance evaluations.

Block Configuration Diagram for Radiated Emission

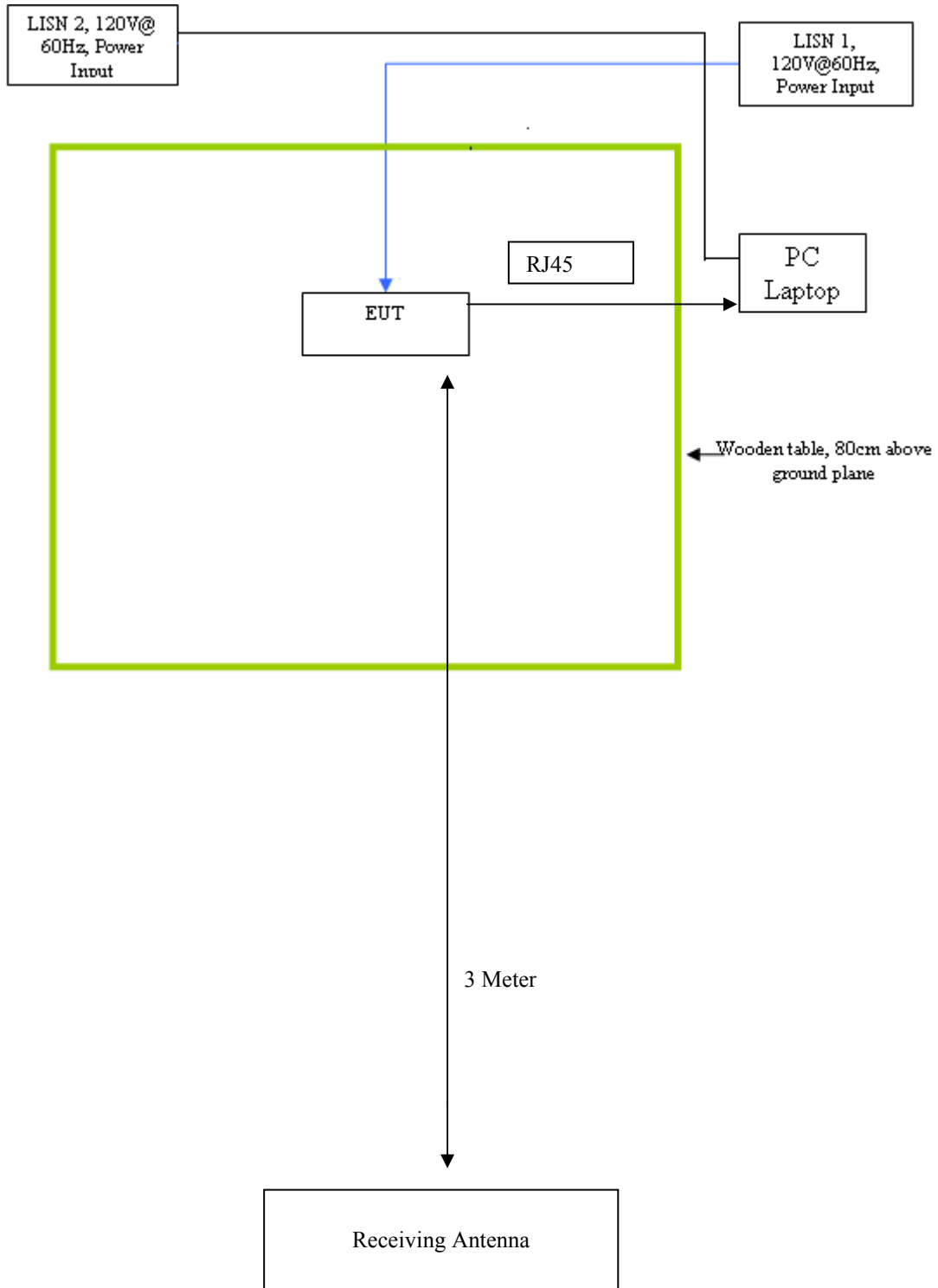

Block Configuration Diagram for Conducted Emission

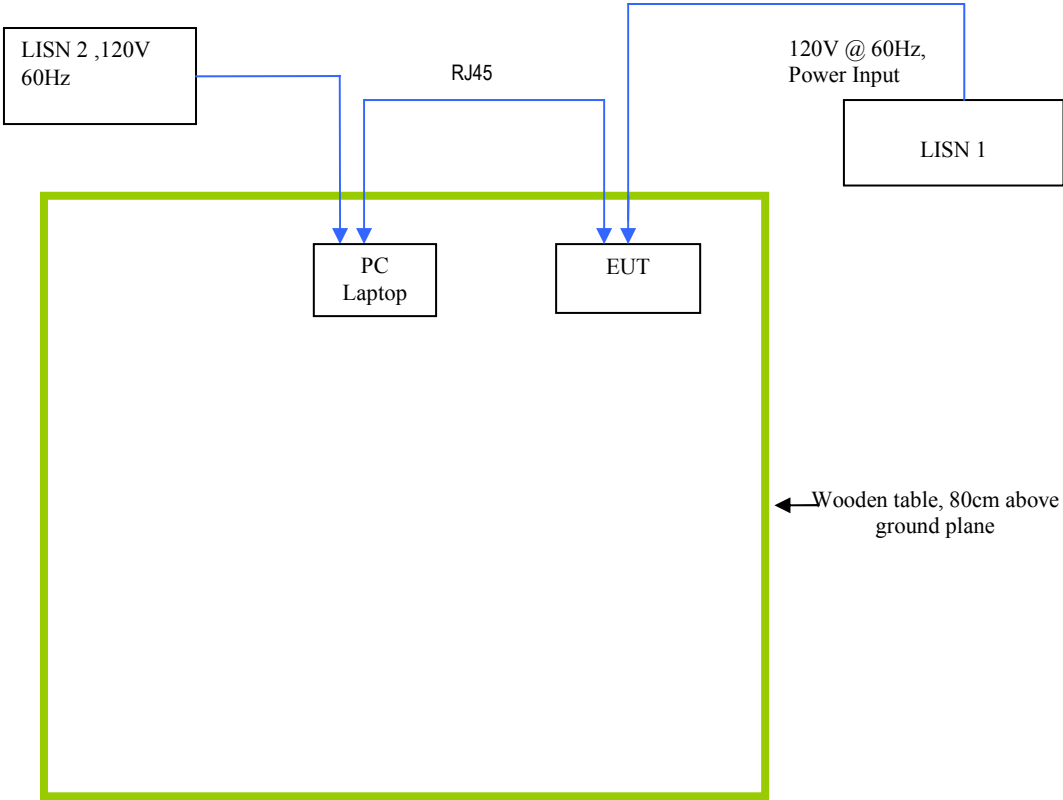

Annex C.ii. EUT OPERATING CONDITIONS

The following is the description of how the EUT is exercised during testing.

Test	Description Of Operation
Emissions Testing	The EUT was controlled by itself Using manufacturer's program.
Others Testing	TX mode is normal mode with full power.

Annex D USER MANUAL, BLOCK & CIRCUIT DIAGRAM

Please see attachment

Annex E SIEMIC ACCREDITATION

SIEMIC ACCREDITATION DETAILS: A2LA 17025 & ISO Guide 65 : 2742.01 , 2742.2



ILAC-MRA
World Class Accreditation

A2LA The American Association for Laboratory Accreditation

Accredited Laboratory

A2LA has accredited

SIEMIC, INC.
dba SIEMIC LABORATORIES
Milpitas, CA
for technical competence in the field of
Electrical Testing

This laboratory is accredited in accordance with the recognized International Standard ISO/IEC 17025:2005 *General Requirements for the Competence of Testing and Calibration Laboratories*. This accreditation demonstrates technical competence for a defined scope and the operation of a laboratory quality management system (refer to joint ISO-ILAC-IAF Communiqué dated 8 January 2009).

Presented this 23rd day of November 2010.

Peter Abney
President & CEO
For the Accreditation Council
Certificate Number 2742.01
Valid to September 30, 2012
Revised August 2, 2012.

For the tests or types of tests to which this accreditation applies, please refer to the laboratory's Electrical Scope of Accreditation.



American Association for Laboratory Accreditation

SCOPE OF ACCREDITATION TO ISO/IEC 17025:2005

SIEMIC, INC. ¹
dba SIEMIC LABORATORIES
775 Montague Expressway
Milpitas, CA 95035
Mr. Leslie Bai Phone: 408 526 1188 Email: leslie.bai@siemic.com
Mr. Snell Leong Phone: 408 526 1188 Email: snell.leong@siemic.com
www.siemic.com

ELECTRICAL

Valid to: September 30, 2012

Certificate Number: 2742.01

In recognition of the successful completion of the A2LA evaluation process, accreditation is granted to this laboratory to perform the following EMC, Product Safety, Radio and Telecommunication tests:

Test Description:	Test Method:
EN & IEC – Emissions & Immunity	IEC/CISPR 11; IEC/CISPR 12; EN 55011; IEC/CISPR 22; EN 55022; IEC/CISPR 20; EN 55020; EN 61000-6-1; EN 61000-6-2; EN 61000-6-3; EN 61000-6-4; EN 61204-3; EN 61326, EN 61326-1; EN 61000-3-2; EN 61000-3-3; EN 50081-1, EN 50081-2; EN 50082-1; IEC 61000-4-2; EN 61000-4-2; IEC 61000-4-3 (limited up to 2.7 GHz and 3V/m); EN 61000-4-3; (limited up to 2.7 GHz and 3V/m); IEC 61000-4-4; EN 61000-4-4; IEC 61000-4-5; EN 61000-4-5; IEC 61000-4-6; EN 61000-4-6; IEC 61000-4-8; EN 61000-4-8; IEC 61000-4-11; EN 61000-4-11; IEC/CISPR 24; EN 55024; EN 50412-2-1; EN 50083-2; EN 50090-2-2; EN 50091-2; EN 50130-4; EN 50130-4 +A12; IEC 60601-1-2; EN 12184; EN 55015; EN 61547; CISPR 16-1-4
Korea – Emissions & Immunity	RRA Public Notification 2011-18; RRA Announce 2010-5; Annex 2(KN 11); Annex 3(KN 13); Annex 4(KN 14-1); Annex 5(KN 22); Annex 6(KN 41); Annex 7(KN 50); Annex 9(KN 15); Annex 10(KN 19); Annex 11(KN 60); Annex 1-1(KN 16-1-1); Annex 1-2(KN 16-1-2); Annex 1-3(KN 16-1-3); Annex 1-4(KN 16-1-4); Annex 1-5(KN 16-1-5); Annex 1-6(KN 16-2-1); Annex 1-7(KN 16-2-2); Annex 1-8(KN 16-2-3); Annex 1-9(KN 16-2-4); RRA Public Notification 2011-17; RRA Announce 2010-6; Annex 1-1(KN 61000-4-2); Annex 1-2(KN 61000-4-3); Annex 1-3(KN 61000-4-4); Annex 1-4(KN 61000-4-5); Annex 1-5(KN 61000-4-6); Annex 1-6(KN 61000-4-8); Annex 1-7(KN 61000-4-11); Annex 2(KN 60601-1-2); Annex 3(KN 20); Annex 5(KN 24); Annex 6(KN 41); Annex 7(KN 51); Annex 8-1(KN 301-489-01); Annex 8-2(KN 301-489-07); Annex 8-3(KN 301-489-17); Annex 8-4(KN 301-489-24)

(A2LA Certificate No. 2742.01) revised 08/02/2012

Page 1 of 8



US / FCC - Emissions	SAE J1113-11, SAE J1113-12; SAE J1113-41; SAE J1113-4; SAE J1113-13; FCC Method 47 CFR Part 18, FCC Report and Order ET Docket 98-153 (FCC 02-48); FCC Method 47 CFR Parts 15, including Subpart G, using FCC Order 04-425 ANSI C63.4(2009); ANSI C63.10(2009); ANSI C63.4:2003 ANSI C63.4(2003) with FCC Method 47 CFR Part 11; ANSI C63.4(2003) with FCC Method 47 CFR Part 15, Subpart E; ANSI C63.4(2003) with FCC Method 47 CFR Part 15, Subpart C; ANSI C63.4(2003) and DA 02-2138; ANSI C63.4(2003) with FCC Method 47 CFR Part 15, Subpart B
Canada – Emissions	ICES-001; ICES-002; ICES-003 Issue 4; ICES-003 Issue 4 (2004); ICES-006 Issue 1
Vietnam – Emission & Immunity	TCN 68-193:2003; TCN 68-196:2001; TCVN 7189:2002; TCVN 7189:2009 (CISPR 22:2006)
Australia / New Zealand – Emissions and Immunity	AS/NZS 1044; AS/NZS 4251.1; AS/NZS 4251.2; AS/NZS CISPR 22; AS/NZS 3548; AS/NZS 2279.3; AS/NZS 61000-3-3; AS/NZS CISPR 11; AS/NZS CISPR 24; AS/NZS 61000.6.3; AS/NZS 61000.6.4; AS/NZS CISPR 14.1; AS/NZS 61000.3.2
Japan – Emissions	JEITA IT-3001; VCCI-V-3:2010.4 (up to 6 GHz)
China – Emissions	GB9254; GB17625.1
Taiwan – Emissions	CNS 13438 (up to 6 GHz); CNS 13783-1; CNS 13803; CNS 13439
Singapore – Emissions & Immunity	IDA TS EMC; CISPR 22; IEC 61000-4-2; IEC 61000-4-3; IEC 61000-4-4; IEC 61000-4-5; IEC 61000-4-6
FCC – Unlicensed Radio A1 to A4	A1: 47 CFR Parts 11 (Emergency Alert System (EAS)), 15 (Radio Frequency Devices) and 18 (Industrial, Scientific, and Medical Equipment); FCC OST/MP-5(1986); ANSI C63.4(2003); ANSI C63.4(2009); ANSI C63.10(2009) A2: 47 CFR Part 15 (Radio Frequency Devices); ANSI C63.4(2003); ANSI C63.4(2009); ANSI C63.10(2009) A3: 47 CFR Part 15 (Radio Frequency Devices); ANSI C63.17:2006; ANSI C63.10(2009); IEEE Std 1528:2003 + Ad1; Std IEEE 1528A:2005 A4: 47 CFR Part 15 (Radio Frequency Devices); ANSI C63.10(2009); IEEE Std 1528:2003 + Ad1; Std IEEE 1528A:2005
FCC – Licensed Radio B1 to B4	B1: 47 CFR Parts 2 (Frequency Allocations and Radio Treaty Matters; General Rules and Regulations), 22 (Public Mobile Services), 24 (Personal Communications Services), 25 (Satellite Communications), and 27 (Miscellaneous Wireless Communications Services); ANSI/TIA-603-C (2004), Land Mobile FM or PM Communications



<p>FCC – Licensed Radio (continued) B1 to B4</p>	<p>Equipment Measurement and Performance Standard; IEEE Std 1528:2003 + Ad1; Std IEEE 1528A:2005 B2: 47 CFR Parts 2 (Frequency Allocations and Radio Treaty Matters; General Rules and Regulations), 22 (Public Mobile Services), 74 (Experimental Radio Auxiliary, Special Broadcast and Other Program Distributional Services), 90 (Private Land Mobile Radio Services), 95 (Personal Radio Services), and 97 (Amateur Radio Services); ANSI/TIA- 603-C (2004), Land Mobile FM or PM Communications Equipment Measurement and Performance Standard B3: 47 CFR Parts 2 (Frequency Allocations and Radio Treaty Matters; General Rules and Regulations); 80 (Stations in the Maritime Services) , 87 (Aviation Services); ANSI/TIA-603-C (2004), Land Mobile FM or PM Communications Equipment Measurement and Performance Standard B4: 47 CFR Parts 2 (Frequency Allocations and Radio Treaty Matters; General Rules and Regulations); 27 (Broadband Radio Services (BRS) and Educational Broadband Services (EBS)), 74 (Experimental Radio Auxiliary, Special Broadcast and Other Program Distributional Services), and 101 (Fixed Microwave Services); ANSI/TIA-603-C (2004), Land Mobile FM or PM Communications Equipment Measurement and Performance Standard</p>
<p>Canada – Radio</p>	<p>RSS 102; RSS 111; RSS 112; RSS 117; RSS 118; RSS 119; RSS 123; RSS 125; RSS 127; RSS 128; RSS 129; RSS 131; RSS 132; RSS 133; RSS 134; RSS 135; RSS 136; RSS 137; RSS 138; RSS 139; RSS 141; RSS 142; RSS 170; RSS 181; RSS 182; RSS 191; RSS 192; RSS 193; RSS 194; RSS 195; RSS 196; RSS 197; RSS 198; RSS 199; RSS 210; RSS 220; RSS 213; RSS 215; RSS 243; RSS 287; RSS 288; RSS 310; RSS Gen</p>
<p>CE – Radio</p>	<p>EN 301 502; EN 301 511; EN 301 526; EN 301 681; EN 301 721; EN 301 751; EN 301 753; EN 301 783-2; EN 301 796; EN 301 797; EN 301 840-2; EN 301 843-1; EN 301 843-4; EN 301 843-5; EN 301 893; EN 301 908-01; EN 301 908-02; EN 301 908-03; EN 301 908-04; EN 301 908-05; EN 301 908-06; EN 301 908-07; EN 301 908-08; EN 301 908-09; EN 301 908-10; EN 301 908-11; EN 301 929-2; EN 301 997-2; EN 302 018-2; EN 302 054-2; EN 302 064-2; EN 302 066-2; EN 302 077-2; EN 302 186; EN 302 195-2; EN 302 217-3; EN 302 245-2; EN 302 288-2; EN 302 291-2; EN 302 296; EN 302 297; EN 302 326-2; EN 302 326-3; EN 302 340; EN 302 372-2; EN 302 426; EN 302 454-2; EN 302 480; EN 302 502; EN 302 510-2;</p>
	<p>EN 302 217-4-2; EN 300 224-1; EN 300 279; EN 300 339; EN 300 385; EN 301 839-2; EN 301 843-6; EN 302 017-2; EN 302 208-2; EN 302 217-2-2; ETS 300 329; ETS 300 445; ETS 300 446; ETS 300 683; ETS 300 826; ETS EN 300 328; ETSI EN 300 086-2; EN 302217-1; EN 302217-2-1; EN 302217-4-1; EN 302288-1; EN 302908-12; EN 302326-1; EN 301929-1; EN 301997-1; EN 300224-2; EN 301839-1; EN 301843-1; EN 301843-2; EN 301843-3; EN 301843-4; EN 301843-5; EN 302017-1; EN 302208-1; EN 300086-1; EN 300113-1; EN 300224-1; EN 300341-1; EN 302291-1; EN 302500-1; EN 302500-2; ETSI EN 300 113-2; ETSI EN 300 197; ETSI EN 300 198;</p>



CE – Radio (continued)	ETSI EN 300 219-1; ETSI EN 300 219-2; ETSI EN 300 220-1; ETSI EN 300 220-2; ETSI EN 300 220-3; ETSI EN 300 224-2; ETSI EN 300 296-1; ETSI EN 300 296-2; ETSI EN 300 328-1; ETSI EN 300 328-2; ETSI EN 300 330; ETSI EN 300 330-1; ETSI EN 300 330-2; ETSI EN 300 341-2; ETSI EN 300 373-1; ETSI EN 300 373-2; ETSI EN 300 373-3; ETSI EN 300 390-1; ETSI EN 300 390-2; ETSI EN 300 422-1; ETSI EN 300 422-2; ETSI EN 300 431; ETSI EN 300 440-1; ETSI EN 300 440-2; ETSI EN 300 454-1; ETSI EN 300 454-2; ETSI EN 300 718-2; ETSI EN 301 021; ETSI EN 301 166-1; ETSI EN 301 166-2; ETSI EN 301 178-2; ETSI EN 301 213-1; ETSI EN 301 213-2; ETSI EN 301 213-3; ETSI EN 301 213-4; ETSI EN 301 213-5; ETSI EN 301 357-1; ETSI EN 301 357-2; ETSI EN 301 390; ETSI EN 301 459; ETSI EN 301 489-01(excluding section 9.6); ETSI EN 301 489-02; ETSI EN 301 489-03; ETSI EN 301 489-04; ETSI EN 301 489-05; ETSI EN 301 489-06; ETSI EN 301 489-07; ETSI EN 301 489-08; ETSI EN 301 489-09; ETSI EN 301 489-10; ETSI EN 301 489-11; ETSI EN 301 489-12; ETSI EN 301 489-13; ETSI EN 301 489-14; ETSI EN 301 489-15; ETSI EN 301 489-16; ETSI EN 301 489-17; ETSI EN 301 489-18; ETSI EN 301 489-19; ETSI EN 301 489-20; ETSI EN 301 489-22; ETSI EN 301 489-23; ETSI EN 301 489-24; ETSI EN 301 489-25; ETSI EN 301 489-26; ETSI EN 301 489-27; ETSI EN 301 489-28; ETSI EN 301 489-31; ETSI EN 301 489-32; IEC 60945
IDA – Radio	IDA TS AR; IDA TS CT-CTS; IDA TS GMPCS; IDA TS LMR; IDA TS RPG; IDA TS SRD; IDA TS UWB; IDA TS WBA; IDA TS CMT; IDA TA CBS
Vietnam – Radio	QCVN 54:2011/BTTTT; TCN 68-242:2006; QCVN 11:2010/BTTTT; TCN 68-243:2006; QCVN 17:2010/BTTTT; TCN 68-246:2006
Korea – Radio	Annex 8-1(KN 301-489-01); Annex 8-2(KN 301-489-07); Annex 8-3(KN 301-489-17); Annex 8-4(KN 301-489-24); KCC Public Notification 2011-31; RRA Announce 2011-10; RRA Public Notification 2010-46
Taiwan – Radio	LP0002; PLMN07; PLMN01; PLMN08
Australia - New Zealand – Radio	AS 2772.2; AS/NZS 4281; AS/NZS 4268; AS/NZS 4280.1; AS/NZS 4583; AS/NZS 4280.2; AS/NZS 4281; AS/NZS 4295; AS/NZS 4582; AS/NZS 4769.1; AS/NZS 4769.2; AS/NZS 4770; AS/NZS 4771
Hong Kong – Radio	HKCA 1002; HKCA 1007; HKCA 1008; HKCA 1010; HKCA 1015; HKCA 1016; HKCA 1020; HKCA 1022; HKCA 1026; HKCA 1027; HKCA 1033; HKCA 1034; HKCA 1035; HKCA 1036; HKCA 1037; HKCA 1039; HKCA 1041; HKCA 1042; HKCA 1043; HKCA 1044; HKCA 1046; HKCA 1047; HKCA 1048; HKCA 1049; HKCA1052; HKCA1053; HKCA 1054



FCC Telephone Terminal Equipment Scope C1 FCC Telephone Terminal Equipment Scope C1 (continued)	ANSI/TIA-968-A:03; ANSI/TIA-968-A-1:03; ANSI/TIA-968-A-2:04; ANSI/TIA-968-A-3:05; ANSI/TIA-968-A-4:07; ANSI/TIA-968-A-5:07; TIA-968-B; FCC Rule Part 68; 47 CFR Part 68.316; 47 CFR Part 68.317; ANSI/TIA/EIA-464-C; TIA-810-B; T1.TRQ6 (2002); TCB-31-B (1998); TIA-470.110-C; TIA-810-B; TIA-920
Canada – Telecom	CS-03 Part V Issue 9:2009 Amendment 1; CS-03 Part VIII Issue 9:2009 Amendment 4; CS-03 Part I Issue 9:2006 Amendment 3; CS-03 Part II Issue 9:2004; CS-03 Part III Issue 9:2004; CS-03 Part V Issue 9:2004 ; CS-03 Part VI Issue 9:2004; CS-03 Part VII Issue 9:2006 Amendment 3; CS-03 Part VIII Issue 9:2007 Amendment 3; CS-03 Issue 9:04 + A2(06) + A3(06)
Europe – Telecom	TBR 2: 01-1997; TBR 004 Ed.1.95 + A1 (97); TBR 1; TBR 3; TBR 12:A1 01-1996; TBR 013 ed.1; TBR 024 ed.1; TBR 25; TBR 38 ed.1; ETSI ES 203 021-05 ; ETSI ES 203 021-2 ; ETSI ES 021-3; TBR 021; ETSI EG 201 121; ETSI EN 301 437; ETSI TS 101 270-1; ITU-T Recommendation Q.920; ITU-T Recommendation Q.920 – Amendment 1; ITU-T Recommendation Q.921; ITU-T Recommendation Q.921 – Amendment 1; ITU-T Recommendation Q.931; ITU-T Recommendation Q.931 – Amendment 1; Erratum 1 (02/2003) ITU-T Recommendation Q.931 (05/1998); ISDN User Network Interface Layer 3 Specification for Basic Call Control; ITU-T Recommendation P.300
Australia –Telecom	AS/CA S003.1:2010; AS/CA S003.2:2010; AS/CA S003.3:2010; AS/CA S004:2010; AS/ACIF S006:2008; AS/ACIF S041.1:2009 AS/ACIF S041.2:2009; AS/ACIF S041.3:2009; AS/ACIF S042.1:2008; AS/ACIF S043.2:2008; AS/ACIF S043.3:2008; AS/ACIF S002:05; AS/ACIF S003:06; AS/ACIF S004:06; AS/ACIF S006:01; AS/ACIF S016:01; AS/ACIF S031:01; AS/ACIF S038:01; AS/ACIF S040:01; AS/ACIF S041:05; AS/ACIF S043.2:06; AS ACIF S042.1
New Zealand – Telecom	PTC200:2006; PTC200 Issue No.2:97 + A1(980); PTC220; PTC273:2007; TNA 115; TNA 117
Singapore – Telecom	IDA TS ADSL; IDA TS DLCN; IDA TS ISDN BA; IDA TS ISDN PRA; IDA TS ISDN 3; IDA TS-PSTN; IDA TS ACLIP
Hong Kong – Telecom	HKCA 2011; HKCA 2012; HKCA 2013; HKCA 2014; HKCA 2015; HKCA 2017; HKCA 2018; HKCA 2019; HKCA 2022; HKCA 2023; HKCA 2024; HKCA 2026; HKCA 2027; HKCA 2028; HKCA 2029; HKCA 2030; HKCA 2031; HKCA 2032; HKCA 2033



Vietnam – Telecom	QCVN 10:2010/BTTTT; TCN 68-143:2003; QCVN 19:2010/BTTTT; TCN 68-188:2000; TCN 68-189:2000; QCVN 18:2010/BTTTT; TCN 68-192:2003; TCN 68-193:2003; TCN 7317:2003 (CISPR 24: 1997); TCN 68-196:2001; QCVN 12:2010/BTTTT; TCN 68-221:2004; QCVN 13:2010/BTTTT; TCN 68-222:2004; QCVN 55:2011/BTTTT; TCN 68-223:2004; QCVN 15:2010/BTTTT; TCN 68-245:2004
Korea – Telecom	Presidential Decree 21098; RRA Public Notification 2010-36; RRA Public Notification 2009-38; RRA Announce 2011-2; Annex 1(RRA Announce 2011-2); Annex 3(RRA Announce 2011-2); Annex 5(RRA Announce 2011-2); Annex 6(RRA Announce 2011-2)
China – Telecom	YD/T 514-1:98; YD/T 1277.1-2003; GB/T 17904.1-1999; GB/T 17904.2-1999; GB/T 17154.1-1997; GB/T 17154.2-1997; YD/T1091-2000; YD/T1006-1999; GB/T 17789-1999
Taiwan – Telecom	PSTN01:03; ADSL01:08; ID0002; IS6100: 93
Japan – Telecom	JATE Blue Book, Green Book; Ministerial Ordinance of the Ministry of Posts and Telecommunications No. 31 of April 1, 1985 (last amended on March 22 2004); Ordinance Concerning Technical Conditions Compliance Approval etc. of Terminal Equipment
South Africa – Telecom	DPT-TE-001; TE-002; TE-003; TE-004; TE-005; TE-006; TE-007; TE-008; TE-009; TE-010; TE-012 (telephone interface); TE-013 (telephone interface); TE-014; TE-015; TE-018; SWS-001; SWS-002; SWS-003; SWS-004; SWS-005; SWS-006; SWS-007; SWS-008; SWS-009; SWS-010
Israel – Telecom	Israel MoC Spe. 23/96
Mexico – Telecom	NOM-151-SCT1-1999; NOM-152-SCT1-1999
Argentina – Telecom	CNC-ST2-44-01
Brazil – Telecom	Resolution 392-2005
International Telecom Union	ITU-T-G.703:01; ITU-T-G.823:93; ITU-T G.824; ITU-T G.825; ITU-T-G.991.2; ITU-T-G.992.1; ITU-T-G.992.3; ITU-T-G.992.5; ITU-T-G.993.1
Product Safety	IEC 60950-1; EN 60950-1; UL 60950-1; IEC 60601-1-1; CAN/CSA 22.2 NO. 60950-1-03; SS-EN 60950-1; AS/NZ 60950-1, (voltage surge testing up to 6kV, excluding Annex A and H); CNS 14336, CNS 14408; GB4943; President Notice 20664; RRA Public Notification 2011-14; RRA Announce 2011-3; Annex 1(RRA Announce 2011-3); QCVN 22:2010/BTTTT; TCN 68-190:2003; SABS IEC 60950; IEC/EN 61558; IEC/EN 61558-2-7; EN 62115; IEC 60215; EN 60958; EN 60598; IEC 215 (1987) + A1 (1992) + A2 (1994)



Japan - Radio	ARIB STD-T81; ARIB STD-T66; RCR STD-1; RCR STD-29; ARIB STD-T94 Fascicle 1; ARIB STD-T90; ARIB STD-T89; RCR STD-33
SAR & HAC	IEEE P1528:2003 + Ad1; IEEE 1528A:2005; FCC OET Bulletin 65 Supplement C; FCC OET Bulletin 65; ANSI C95; ANSI C63.19; FCC 47 CFR 20.19; H46-2/99-273E; EN 50360; EN 50361; IEC62209-1; IEC 62209-2; EN 50371; EN 50383; EN 50357; EN 50364; KCC Public Notification 2009-27; RRA Public Notification 2010-45; KCC Public Notification 2011-10; CNS 14958-1; CNS 14959; NZS 2772.1; NZS 6609.2; Resolution N 533
Japan – Notification No. 88 of MIC 2004	
Table No 13	CB Radio
Table No 21	Cordless Telephone
Table Nos 22-1 thru 22-17	Low Power Radio Equipment
Table No 36	Low Power Security System
Table No 43	Low Power Data Communication in the 2.4 GHz Band
Table No 44	Low Power Data Communication in the 2.4 GHz Band
Table No 45	Low Power Data Communication in the 5.2, 5.3, 5.6 GHz Bands
Table No 46	Low Power Data Communication in the 25 and 27 GHz Bands
Table No 47	Base Station for 5 GHz Band Wireless Access System
Table No 47	Base Station for 5 GHz Band Wireless Access System (low spurious type)
Table No 47	Land Mobile Relay for 5 GHz Band Wireless Access System (limited for use in special zones)
Table No 47	Land Mobile Relay for 5 GHz Band Wireless Access System (limited for use in special zones, low spurious type)
Table No 47	Land Mobile Relay for 5 GHz Band Wireless Access System
Table No 47	Land Mobile Relay for 5 GHz Band Wireless Access System (low spurious type)
Table No 47	Land Mobile Relay for 5 GHz Band Wireless Access System (low power type)
Table No 50	Digital Cordless Telephone
Table No 50	PHS Base Station
Table No 50	PHS Land Mobile Station
Table No 50	PHS Relay Station
Table No 50	PHS Test Station
Table No 64	Mobile Station for Dedicated Short Range Communication Systems



Japan – Notification No. 88 of MIC 2004 (cont.)	
Table No 64	Base Station for Dedicated Short Range Communication Systems
Table No 64	Test Station for Dedicated Short Range Communication Systems
Table No 70	UWB (Ultra Wide Band) Radio System

*Limitations for listed standards are indicated by italics and Scope excludes protocol sections of applicable standards.



SIEMIC, INC.

Accessing global markets

Title: RF Test Report Exalt Communications, Inc., model : Radio Module
5 GHz
To FCC 15.407 2011, RSS 210 Issue 8: 2010

Serial# SL12031601-EXA-009R1 rev3.0
Issue Date 13 March 2013
Page 321 of 339
www.siemic.com



The American Association for Laboratory Accreditation

"World Class Accreditation"

Accredited Product Certification Body

A2LA has accredited

SIEMIC, INC.

Milpitas, CA

for technical competence as a

Product Certification Body

This product certification body is accredited in accordance with the recognized International Standard ISO/IEC Guide 65:1996. *General requirements for bodies operating product certification systems.* This accreditation demonstrates technical competence for a defined scope and the operation of a quality management system.

Presented this 23rd day of November 2010.



President & CEO
For the Accreditation Council
Certificate Number 2742.02
Valid to September 30, 2012
Revised August 2, 2012

For the product certification schemes to which this accreditation applies, please refer to the organization's Product Certification Scope of Accreditation



SIEMIC, INC.

Accessing global markets

Title: RF Test Report Exalt Communications, Inc., model : Radio Module
5 GHz
To FCC 15.407 2011, RSS 210 Issue 8: 2010

Serial# SL12031601-EXA-009R1 rev3.0
Issue Date 13 March 2013
Page 322 of 339
www.siemic.com



American Association for Laboratory Accreditation

SCOPE OF ACCREDITATION TO ISO/IEC GUIDE 65:1996

SIEMIC, INC.
775 Montague Expressway
Milpitas, CA 95035
Mr. Snell Leong (Authorized Representative) Phone: 408 526 1188
www.siemic.com

PRODUCT CERTIFICATION CONFORMITY ASSESSMENT BODY (CAB)

Valid to: September 30, 2012

Certificate Number: 2742.02

In recognition of the successful completion of the A2LA Certification Body Accreditation Program evaluation, including the US Federal Communications Commission (FCC), Industry Canada (IC), Singapore (IDA), Hong Kong (OFCA) and Japan (MIC) requirements for the indicated types of product certifications, accreditation is granted to this organization to perform the following product certification schemes:

Economy

Scope

Federal Communication Commission - (FCC)

Unlicensed Radio Frequency Devices	A1, A2, A3, A4
Licensed Radio Frequency Devices	B1, B2, B3, B4
Telephone Terminal Equipment	C

**Please refer to FCC TCB Program Roles and Responsibilities, released July 22, 2010 detailing scopes, roles and responsibilities. <http://fialfoss.fcc.gov/oetcf/kdb/forms/FTSSearchResultPage.cfm?id=44683&switch=P>*

Industry Canada - (IC)

Radio	Scope 1-Licence-Exempt Radio Frequency Devices; Scope 2-Licensed Personal Mobile Radio Services; Scope 3-Licensed General Mobile & Fixed Radio Services; Scope 4-Licensed Maritime & Aviation Radio Services; Scope 5-Licensed Fixed Microwave Radio Services;
-------	--

**Please refer to Industry Canada (IC) website at: <http://www.ic.gc.ca/eic/site/smt-gst.nsf/eng/sf09888.html>*

IDA – Singapore

Line Terminal Equipment	All Technical Specifications for Line Terminal Equipment – Table 1 of IDA MRA Recognition Scheme: 2011, Annex 2
Radio-Communication Equipment	All Technical Specifications for Radio-Communication Equipment – Table 2 of IDA MRA Recognition Scheme: 2011, Annex 2

**Please refer to Info-Communication Development Authority (IDA) Singapore website at: http://www.ida.gov.sg/doc/Policies%20and%20Regulation/Policies_and_Regulation_Level2/20060609145118/MRARecScheme.pdf*

(A2LA Cert. No. 2742.02) Revised 07/17/2012

Page 1 of 2



OFCA – Hong Kong

Radio Equipment HKCA 1001, 1002, 1003, 1004, 1005, 1006, 1007, 1008, 1009, 1010, 1015, 1016, 1019, 1020, 1022, 1026, 1027, 1033, 1034, 1035, 1036, 1037, 1038, 1039, 1041, 1042, 1043, 1044, 1045, 1046, 1047, 1048, 1049, 1050, 1052, 1053, 1054

**Please refer to the Office of the Communications Authority's website at:
Radio Equipment Specifications (HKCA 10XX)*

Fixed Network Equipment HKCA 2001, 2005, 2011, 2012, 2013, 2014, 2015, 2016, 2017, 2018, 2019, 2020, 2021, 2022, 2023, 2024, 2026, 2027, 2028, 2029, 2030, 2031, 2032, 2033, 2034, 2035, 2036, 2037, 2040, 2041, 2102, 2103, 2104, 2108, 2201, 2202, 2203, 2204

**Please refer to the Office of the Communications Authority's website at:
Fixed Network Equipment Specifications (HKCA 2XXX)*

MIC – Japan

Telecommunications Business Law (Terminal Equipment) Scope A1 - Terminal Equipment for the Purpose of Calls

Radio Law (Radio Equipment) Scope B1 - Specified Radio Equipment specified in, Article 38-2-2, paragraph 1, item 1 of the Radio Law



SIEMIC, Inc.
Accessing global markets

Title: RF Test Report Exalt Communications, Inc., model : Radio Module
5 GHz
To FCC 15.407 2011, RSS 210 Issue 8: 2010

Serial# SL12031601-EXA-009R1 rev3.0
Issue Date 13 March 2013
Page 324 of 339
www.sieminc.com

SIEMIC ACCREDITATION DETAILS: FCC Test Site Registration No. 881796

FEDERAL COMMUNICATIONS COMMISSION

**Laboratory Division
7435 Oakland Mills Road
Columbia, MD 21046**

August 03, 2012

Registration Number: 881796

SIEMIC Labs
775 Montague Expressway,
Milpitas, CA 95035

Attention: Leslie BAI

Re: Measurement facility located at 775 Montague Expressway, Milpitas, CA 95035
Anechoic chamber (10 meters)
Date of Listing: August 03, 2012

Dear Sir or Madam:

Your request for registration of the subject measurement facility has been reviewed and found to be in compliance with the requirements of Section 2.948 of the FCC rules. The information has, therefore, been placed on file and the name of your organization added to the list of facilities whose measurement data will be accepted in conjunction with applications for Certification under Parts 15 or 18 of the Commission's Rules. Please note that the file must be updated for any changes made to the facility and the registration must be renewed at least every three years.

Measurement facilities that have indicated that they are available to the public to perform measurement services on a fee basis may be found on the FCC website www.fcc.gov under E-Filing, OET Equipment Authorization Electronic Filing, Test Firms.

Sincerely,

Katie Hawkins
Electronics Engineer



SIEMIC, INC.
Accessing global markets

Title: RF Test Report Exalt Communications, Inc., model : Radio Module
5 GHz
To: FCC 15.407 2011, RSS 210 Issue 8: 2010

Serial# SL12031601-EXA-009R1 rev3.0
Issue Date 13 March 2013
Page 325 of 339
www.siemic.com

SIEMIC ACCREDITATION DETAILS: Industry of Canada CAB ID : US0160



UNITED STATES DEPARTMENT OF COMMERCE
National Institute of Standards and Technology
Gaithersburg, Maryland 20899

March 4, 2009

Mr. Leslie Bai
SIEMIC, Inc.
2206 Ringwood Avenue
San Jose, CA 95131

Dear Mr. Bai:

NIST is pleased to inform you that your laboratory has been recognized by Industry Canada (IC), under the Asia Pacific Economic Cooperation for Telecommunications Equipment Mutual Recognition Arrangement (APEC Tel MRA). Your laboratory is now designated to act as a Conformity Assessment Body (CAB) under Appendix B, **Phase I** Procedures, of the APEC Tel MRA. The pertinent information about your laboratory's designation is as follows:

CAB Name: SIEMIC, Inc.
Physical Location: 2206 Ringwood Avenue, San Jose, CA 95131 USA
Identification No.: US0160
Recognized Scope: CS-03 Part I, II, V, VI, VII and VIII

You may submit test data to IC to verify that the equipment to be imported into Canada satisfies the applicable requirements. The designation of your organization will remain in force as long as its accreditation for the designated scope remains valid and comply with the designation requirements.

Recognized CABs are listed on the NIST website at <http://ts.nist.gov/mra>. Please contact Ms. Ramona Saar at (301) 975-5521 or ramona.saar@nist.gov if you have any questions.

Sincerely,

David F. Alderman
Group Leader, Standards Coordination and Conformity Group
Standards Services Division

Enclosure

cc: CAB Program Manager

NIST



SIEMIC, INC.
Accessing global markets

Title: RF Test Report Exalt Communications, Inc., model : Radio Module
5 GHz
To: FCC 15.407 2011, RSS 210 Issue 8: 2010

Serial# SL12031601-EXA-009R1 rev3.0
Issue Date 13 March 2013
Page 326 of 339
www.sieminc.com

SIEMIC ACCREDITATION DETAILS: Industry of Canada Test Site Registration No. 4842-1

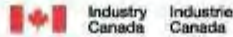

July 03, 2012

OUR FILE: 46405-4842
Submission No: 157820

Siemic Inc.
775 Montague Expressway
Milpitas, CA, 95035
United States

Attention:

Dear Sir/Madame: Snell Leong

The Bureau has received your application for the renewal of 3/10m alternative test site. Be advised that the information received was satisfactory to Industry Canada. The following number(s) is now associated to the site(s) for which registration / renewal was sought (**Site# 4842D-2**). Please reference the appropriate site number in the body of test reports containing measurements performed on the site. In addition, please keep for your records the following information;

- The company address code associated to the site(s) located at the above address is: **4842D**

Furthermore, to obtain or renew a unique site number, the applicant shall demonstrate that the site has been accredited to ANSI C63.4-2003 or later. A scope of accreditation indicating the accreditation by a recognized accreditation body to ANSI C63.4-2003 or later shall be accepted. Please indicate in a letter the previous assigned site number if applicable and the type of site (example: 3 metre OATS or 3 metre chamber). If the test facility is not accredited to ANSI C63.4-2003 or later, the test facility shall submit test data demonstrating full compliance with the ANSI standard. The Bureau will evaluate the filing to determine if recognition shall be granted.

The frequency for re-validation of the test site and the information that is required to be filed or retained by the testing party shall comply with the requirements established by the accrediting organization. However, in all cases, test site re-validation shall occur on an interval not to exceed **three years**. There is no fee or form associated with an OATS filing. OATS submissions are encouraged to be submitted electronically to the Bureau using the following URL:
http://strategis.ic.gc.ca/epic/internet/inceb-bhst.nsf/en/h_t100052e.html.

If you have any questions, you may contact the Bureau by e-mail at certification.bureau@ic.gc.ca. Please reference our file and submission number above for all correspondence.

Yours sincerely,

Dalwinder Gill
Wireless Laboratory Manager
Certification and Engineering Bureau
3701 Carling Ave., Building 54
P.O. Box 11490, Station "H"
Ottawa, Ontario K2H 832
Email: dalwinder.gill@ic.gc.ca
Tel. No. (613) 998-8363
Fax No. (613) 990-4752



SIEMIC, INC.

Accessing global markets

Title: RF Test Report Exalt Communications, Inc., model : Radio Module
5 GHz
To FCC 15.407 2011, RSS 210 Issue 8: 2010

Serial# SL12031601-EXA-009R1 rev3.0
Issue Date 13 March 2013
Page 327 of 339
www.siemec.com

SIEMIC ACCREDITATION DETAILS: FCC DOC CAB Recognition : US1109

FEDERAL COMMUNICATIONS COMMISSION

**Laboratory Division
7435 Oakland Mills Road
Columbia, MD 21046**

August 28, 2008

Siemic Laboratories
2206 Ringwood Ave.,
San Jose, CA 95131

Attention: Leslie Bai

Re: Accreditation of Siemic Laboratories
Designation Number: US1109
Test Firm Registration #: 540430

Dear Sir or Madam:

We have been notified by American Association for Laboratory Accreditation that Siemic Laboratories has been accredited as a Conformity Assessment Body (CAB).

At this time Siemic Laboratories is hereby designated to perform compliance testing on equipment subject to Declaration Of Conformity (DOC) and Certification under Parts 15 and 18 of the Commission's Rules.

This designation will expire upon expiration of the accreditation or notification of withdrawal of designation.

Sincerely,

George Tannahill
Electronics Engineer



SIEMIC, Inc.

Accessing global markets

Title: RF Test Report Exalt Communications, Inc., model : Radio Module
5 GHz
To FCC 15.407 2011, RSS 210 Issue 8: 2010

Serial# SL12031601-EXA-009R1 rev3.0
Issue Date 13 March 2013
Page 328 of 339
www.sieminc.com

SIEMIC ACCREDITATION DETAILS: Australia CAB ID : US0160



UNITED STATES DEPARTMENT OF COMMERCE
National Institute of Standards and Technology
Gaithersburg, Maryland 20899

November 20, 2008

Mr. Leslie Bai
SIEMIC, Inc.
2206 Ringwood Avenue
San Jose, CA 95131

Dear Mr. Bai:

NIST is pleased to inform you that your laboratory has been recognized by the Australian Communications and Media Authority (ACMA) under the Asia Pacific Economic Cooperation for Telecommunications Equipment Mutual Recognition Arrangement (APEC Tel MRA). Your laboratory is now designated to act as a Conformity Assessment Body (CAB) under Appendix B, **Phase I** Procedures, of the APEC Tel MRA. The pertinent information about your laboratory's designation is as follows:

CAB Name: Siemic, Inc.
Physical Location: 2206 Ringwood Avenue, San Jose, CA 95131
Identification No.: US0160
Recognized Scope: EMC: AS/NZS 4251.1 (until 5/31/2009), AS/NZS 4251.2 (until 5/31/2009), AS/NZS CISPR 11, AS/NZS CISPR 14.1, AS/NZS CISPR 22, AS/NZS 61000.6.3, AS/NZS 61000.6.4
Radiocommunications: AS/NZS 4281, AS/NZS 4268, AS/NZS 4280.1, AS/NZS 4280.2, AS/NZS 4295, AS/NZS 4582, AS/NZS 4583, AS/NZS 4769.1, AS/NZS 4769.2, AS/NZS 4770, AS/NZS 4771
Telecommunications: AS/ACIF S002:05, AS/ACIF S003:06, AS/ACIF S004:06, AS/ACIF S006:01, AS/ACIF S016:01, AS/ACIF S031:01, AS/ACIF S038:01, AS/ACIF S040:01, AS/ACIF S041:05, AS/ACIF S043.2:06, AS/NZS 60950.1

You may submit test data to ACMA to verify that the equipment to be imported into Australia satisfies the applicable requirements. The designation of your organization will remain in force as long as its accreditation for the designated scope remains valid and comply with the designation requirements. Recognized CABs are listed on the NIST website at <http://ts.nist.gov/mra>. Please contact Ms. Ramona Saar, at (301) 975-5521 or ramona.saar@nist.gov if you have questions.

Sincerely,

David F. Alderman
Group Leader, Standards Coordination and Conformity Group
Standards Services Division

Enclosure

cc: Snell Leong, Siemic, Inc.; Ramona Saar, NIST

NIST



SIEMIC, Inc.
Accessing global markets

Title: RF Test Report Exalt Communications, Inc., model : Radio Module
5 GHz
To FCC 15.407 2011, RSS 210 Issue 8: 2010

Serial# SL12031601-EXA-009R1 rev3.0
Issue Date 13 March 2013
Page 329 of 339
www.sieminc.com

SIEMIC ACCREDITATION DETAILS: Korea CAB ID: US0160



UNITED STATES DEPARTMENT OF COMMERCE
National Institute of Standards and Technology
Gaithersburg, Maryland 20899

December 6, 2011

Mr. Leslie Bai
SIEMIC, Inc.
2206 Ringwood Avenue
San Jose, CA 95131

Dear Mr. Bai:

NIST is pleased to inform you that your laboratory's recognition by the Radio Research Agency (RRA) Korea Communications Commission (KCC) under the Asia Pacific Economic Cooperation for Telecommunications Equipment Mutual Recognition Arrangement (APEC Tel MRA) has been updated. The pertinent information about your laboratory's designation is as follows:

CAB Name: SIEMIC, Inc.
Physical Location: 2206 Ringwood Avenue, San Jose, CA 95131
Identification No.: US0160
Current Scope: **EMI:** KCC Notice 2008-39; RRA Public Notification 2011-5; KN22
EMS: KCC Notice 2008-38; RRA Public Notification 2011-6, KN24
Updated Scope: **EMI:** RRA Public Notification 2011-18; RRA Announce 2010-5; KN 11; KN 13;
KN 14-1; KN 22; KN 41; KN50; KN15; KN19; KN60; KN16-1-1; KN16-1-2;
KN16-1-3; KN16-1-4; KN16-1-5; KN16-2-1; KN16-2-2; KN 16-2-3; KN 16-2-4;
EMS: RRA Public Notification 2011-17; RRA Announce 2010-6; KN24; KN 61000-4-2,
-4-3, -4-4, -4-5, -4-6, -4-8, -4-11; KN60101-1-2, KN20; KN41, KN51;
RF: KCC Public Notification 2011-31; KCC Public Notification 2011-10;
RRA Public Notification 2010-46; KN301-489-1; KN301-489-07; KN301-489-17; KN
301-489-24
SAR: KCC Public Notification 2009-27; RRA Public Notification 2010-45; KCC
Public Notification 2011-10
TELECOM: RRA Public Notification 2010-36; RRA Public Notification 2009-38

You may submit test data to RRA/KCC to verify that the equipment to be imported into Korea satisfies the applicable requirements. The designation of your organization will remain in force as long as the accreditation for the designated scope remains valid and complies with the designation requirements.

Recognized CABs are listed on the NIST website at <http://ts.nist.gov/mra>. If you have any questions please, contact me at (301) 975-5521 or via email at ramona.saar@nist.gov.

Sincerely,

Ramona Saar
Standards Services Group

Enclosure

NIST



SIEMIC, Inc.
Accessing global markets

Title: RF Test Report Exalt Communications, Inc., model : Radio Module
5 GHz
To: FCC 15.407 2011, RSS 210 Issue 8: 2010

Serial# SL12031601-EXA-009R1 rev3.0
Issue Date 13 March 2013
Page 330 of 339
www.siemic.com

SIEMIC ACCREDITATION DETAILS: Taiwan BSMI Accreditation No. SL2-IN-E-1130R



UNITED STATES DEPARTMENT OF COMMERCE
National Institute of Standards and Technology
Gaithersburg, Maryland 20888

May 3, 2006

Mr. Leslie Bai
SIEMIC Laboratories
7206 Ringwood Avenue
San Jose, CA 95131

Dear Mr. Bai:

I am pleased to inform you that your laboratory has been recognized by the Chinese Taipei's Bureau of Standards, Metrology, and Inspection (BSMI) under the Asia Pacific Economic Cooperation (APEC) Mutual Recognition Arrangement (MRA). Your laboratory is now designated to act as a Conformity Assessment Body (CAB) under Appendix B, Phase I Procedures, of the APEC Tel MRA. You may submit test data to BSMI to verify that the equipment to be imported into Chinese Taipei satisfies the applicable requirements. The designation of your organization will remain in force as long as its accreditation for the designated scope remains valid and comply with the designation requirements. The pertinent designation information is as follows:

- BSMI number: **SL2-IN-E-1130R** (Must be applied to the test reports)
- U.S. Identification No: **US0160**
- Scope of Designation: **CNS 13438**
- Authorized signatory: **Mr. Leslie Bai**

The names of all recognized CABs will be posted on the NIST website at <http://ts.nist.gov/mra>. If you have any questions, please contact Mr. Dhillon at 301-975-5521. We appreciate your continued interest in our international conformity assessment activities.

Sincerely,

David F. Alderman
Group Leader, Standards Coordination and Conformity Group

cc: Joginder Dhillon

NIST



SIEMIC, Inc.

Accessing global markets

Title: RF Test Report Exalt Communications, Inc., model : Radio Module
5 GHz
To FCC 15.407 2011, RSS 210 Issue 8: 2010

Serial# SL12031601-EXA-009R1 rev3.0
Issue Date 13 March 2013
Page 331 of 339
www.sieminc.com

SIEMIC ACCREDITATION DETAILS: Taiwan NCC CAB ID: US0160



UNITED STATES DEPARTMENT OF COMMERCE
National Institute of Standards and Technology
Gaithersburg, Maryland 20899

April 25, 2011

Mr. Leslie Bai
SIEMIC, Inc.
2206 Ringwood Avenue
San Jose, CA 95131

Dear Mr. Bai:

NIST is pleased to inform you that your laboratory has been recognized by the National Communications Commission (NCC) under the Asia Pacific Economic Cooperation for Telecommunications Equipment Mutual Recognition Arrangement (APEC Tel MRA). Your laboratory is now designated to act as a Conformity Assessment Body (CAB) under Appendix B, **Phase I** Procedures, of the APEC Tel MRA. The pertinent information about the laboratory's designation is as follows:

CAB Name: SIEMIC, Inc.
Physical Location: 2206 Ringwood Avenue, San Jose, CA 95131
Identification No.: US0160
Previous Scope: LP0002, PSTN01, ADSL01, ID0002, IS6100, CNS 14336, PLMN07
Current Scope: LP0002, PSTN01, ADSL01, ID0002, IS6100, CNS 14336, PLMN07, PLMN01 and PLMN08

You may submit test data to NCC to verify that the equipment to be imported into Chinese Taipei satisfies the applicable requirements. The designation of your organization will remain in force as long as its accreditation for the designated scope remains valid and comply with the designation requirements.

Recognized CABs are listed on the NIST website at <http://ts.nist.gov/mra>. If you have any questions please contact Ramona Saar at (301) 975-5521 or ramona.saar@nist.gov.

Sincerely,

David F. Alderman
Standards Services Group

Enclosure

cc: Ramona Saar

NIST



SIEMIC, Inc.

Accessing global markets

Title: RF Test Report Exalt Communications, Inc., model : Radio Module
5 GHz
To: FCC 15.407 2011, RSS 210 Issue 8: 2010

Serial# SL12031601-EXA-009R1 rev3.0
Issue Date 13 March 2013
Page 332 of 339
www.siemic.com

SIEMIC ACCREDITATION DETAILS: Vietnam CAB ID: US0160



UNITED STATES DEPARTMENT OF COMMERCE
National Institute of Standards and Technology
Gaithersburg, Maryland 20899

July 11, 2012

Mr. Leslie Bai
SIEMIC, Inc.
2206 Ringwood Avenue
San Jose, CA 95131

Dear Mr. Bai:

NIST is pleased to inform you that your laboratory continues to be recognized by Vietnam's Ministry of Information and Communication (MIC) under the Asia Pacific Economic Cooperation for Telecommunications Equipment Mutual Recognition Arrangement (APEC Tel MRA). MIC has updated your scope of recognition. The pertinent information about the continued recognition is as follows:

CAB Name: SIEMIC, Inc.
Physical Location: 2206 Ringwood Avenue, San Jose, CA 95131
Identification No.: US0160
Current Scope: TCN68-188, TCN68-190, TCN68-193, TCN68-196, TCN68-143, TCN68-192, TCN68-189, TCN68-221, TCN68-222, TCN68-223, TCN68-245, TCN68-242, TCN68-243, TCN68-246, TCVN 7189
Updated Scope: QCVN 19:2010/BTTTT, QCVN 22:2010/BTTTT, TCVN 7189:2009, TCVN 7317:2003, QCVN 10:2010/BTTTT, QCVN 12:2010/BTTTT, QCVN 3:2010/BTTTT, QCVN 15:2010/BTTTT, QCVN 11:2010/BTTTT, QCVN 54:2011/BTTTT, QCVN 55:2011/BTTTT, QCVN 18:2010/BTTTT, QCVN 17:2010/BTTTT

You may submit test data to MIC to verify that the equipment to be imported into Vietnam satisfies the applicable requirements. *Please note that your recognition from Vietnam will expire on **September 30, 2012**. To continue the recognition beyond this date, it will be necessary to submit to NIST the updated ISO/IEC 17025 Scope and Certification of Accreditation as soon as it is reissued during your next accreditation renewal period. NIST will then submit the updated information to MIC so that the recognition can be extended.*

Recognized CABs are listed on the NIST website at <http://gsi.nist.gov/global/index.cfm/L.1-4/L.2-16/L.3-90/A-380>. If you have any questions please contact Ramona Saar via email at ramona.saar@nist.gov or phone at (301) 975-5521.

Sincerely,

David F. Alderman
Standards Services Group

Enclosure

cc: Ramona Saar

NIST



SIEMIC ACCREDITATION DETAILS: Mexico NOM Recognition



CAMARA NACIONAL
DE LA INDUSTRIA
ELECTRONICA, DE
TELECOMUNICACIONES
E INFORMÁTICA

Laboratorio Valentin V. Rivero

México D.F. a 16 de octubre de 2006.

**LESLIE BAI
DIRECTOR OF CERTIFICATION
SIEMIC LABORATORIES, INC.
ACCESSING GLOBAL MARKETS
P R E S E N T E**

En contestación a su escrito de fecha 5 de septiembre del año en curso, le comento que estamos muy interesados en su intención de firmar un Acuerdo de Reconocimiento Mutuo, para lo cual adjunto a este escrito encontrara el Acuerdo en idioma inglés y español preferido de los cuales le pido sea revisado y en su caso corregido, para que si está de acuerdo poder firmarlo para mandarlo con las autoridades Mexicanas para su visto bueno y así poder ejercer dicho acuerdo.

Aprovecho este escrito para mencionarle que nuestro intermediario gestor será la empresa Isotel de México, S. A. de C. V., empresa que ha colaborado durante mucho tiempo con nosotros en lo relacionado a la evaluación de la conformidad y que cuenta con amplia experiencia en la gestión de la certificación de cumplimiento con Normas Oficiales Mexicanas de producto en México.

Me despido de usted enviándole un cordial saludo y esperando sus comentarios al Acuerdo que nos ocupa.

Atentamente:

**Ing. Faustino Gomez Gonzalez
Gerente Técnico del Laboratorio de
CANIETI**

Calle 11
Paseo de la Reforma
Centro Mexico, D.F.
Tel. 5204 6008 con 12 líneas
Fax: 5204 6444
www.canietit.org

SIEMIC ACCREDITATION DETAILS: Hong Kong OFTA CAB ID : US0160



UNITED STATES DEPARTMENT OF COMMERCE
National Institute of Standards and Technology
Gaithersburg, Maryland 20899-

December 8, 2008

Mr. Leslie Bai
SIEMIC, Inc.
2206 Ringwood Avenue
San Jose, CA 95131

Dear Mr. Bai:

NIST is pleased to inform you that your laboratory has been recognized by the Office of the Telecommunications Authority (OFTA) under the Asia Pacific Economic Cooperation for Telecommunications Equipment Mutual Recognition Arrangement (APEC Tel MRA). Your laboratory is now designated to act as a Conformity Assessment Body (CAB) under Appendix B, **Phase I** Procedures, of the APEC Tel MRA. The pertinent information about your laboratory's designation is as follows:

CAB Name: SIEMIC, Inc.
Physical Location: 2206 Ringwood Avenue, San Jose, California 95131 USA
Identification No.: US0160
Recognized Scope: **Radio:** HKTA 1002, 1007, 1008, 1010, 1015, 1016, 1020, 1022, 1026, 1027, 1029, 1030, 1031, 1032, 1033, 1034, 1035, 1036, 1037, 1039, 1041, 1042, 1043, 1044, 1046, 1047, 1048, 1049, 1051
Telecom: HKTA 2011, 2012, 2013, 2014, 2017, 2018, 2022, 2024, 2026, 2027, 2028, 2029, 2030, 2031, 2032, 2033

You may submit test data to OFTA to verify that the equipment to be imported into Hong Kong satisfies the applicable requirements. The designation of your organization will remain in force as long as its accreditation for the designated scope remains valid and comply with the designation requirements.

Recognized CABs are listed on the NIST website at <http://ts.nist.gov/mra>. If you have any questions please contact Ramona Saar at (301) 975-5521 or ramona.saar@nist.gov.

Sincerely,

David F. Alderman
Group Leader, Standards Coordination and Conformity Group
Standards Services Division

Enclosure

cc: Ramona Saar

SIEMIC ACCREDITATION DETAILS: Australia ACMA CAB ID: US0160



UNITED STATES DEPARTMENT OF COMMERCE
National Institute of Standards and Technology
Gaithersburg, Maryland 20899-

November 20, 2008

Mr. Leslie Bai
SIEMIC, Inc.
2206 Ringwood Avenue
San Jose, CA 95131

Dear Mr. Bai:

NIST is pleased to inform you that your laboratory has been recognized by the Australian Communications and Media Authority (ACMA) under the Asia Pacific Economic Cooperation for Telecommunications Equipment Mutual Recognition Arrangement (APEC Tel MRA). Your laboratory is now designated to act as a Conformity Assessment Body (CAB) under Appendix B, **Phase I** Procedures, of the APEC Tel MRA. The pertinent information about your laboratory's designation is as follows:

CAB Name: Siemic, Inc.
Physical Location: 2206 Ringwood Avenue, San Jose, CA 95131
Identification No.: US0160
Recognized Scope: EMC: AS/NZS 4251.1 (until 5/31/2009), AS/NZS 4251.2 (until 5/31/2009), AS/NZS CISPR 11, AS/NZS CISPR 14.1, AS/NZS CISPR 22, AS/NZS 61000.6.3, AS/NZS 61000.6.4
Radiocommunications: AS/NZS 4281, AS/NZS 4268, AS/NZS 4280.1, AS/NZS 4280.2, AS/NZS 4295, AS/NZS 4582, AS/NZS 4583, AS/NZS 4769.1, AS/NZS 4769.2, AS/NZS 4770, AS/NZS 4771
Telecommunications: AS/ACIF S002:05, AS/ACIF S003:06, AS/ACIF S004:06, AS/ACIF S006:01, AS/ACIF S016:01, AS/ACIF S031:01, AS/ACIF S038:01, AS/ACIF S040:01, AS/ACIF S041:05, AS/ACIF S043.2:06, AS/NZS 60950.1

You may submit test data to ACMA to verify that the equipment to be imported into Australia satisfies the applicable requirements. The designation of your organization will remain in force as long as its accreditation for the designated scope remains valid and comply with the designation requirements. Recognized CABs are listed on the NIST website at <http://ts.nist.gov/mra>. Please contact Ms. Ramona Saar, at (301) 975-5521 or ramona.saar@nist.gov if you have questions.

Sincerely,

David F. Alderman
Group Leader, Standards Coordination and Conformity Group
Standards Services Division

Enclosure

cc: Snell Leong, Siemic, Inc.; Ramona Saar, NIST

NIST



SIEMIC ACCREDITATION DETAILS: Australia NATA Recognition



Leslie Bai
SIEMIC, Inc.
2206 Ringwood Avenue
San Jose, CA 95131

November 4, 2008

Under Australian government legislation, the Australian Communications and Media Authority (ACMA) has determined the National Association of Testing Authorities, Australia (NATA) as an accreditation body as per Section 409(1) of the Telecommunications Act 1997 (Cth). Pursuant to Section 409(2) of the Telecommunications Act 1997 (Cth), I am pleased to advise that your laboratory has been determined as a Recognised Testing Authority (RTA).

This determination has been made on the basis of your accreditation by A2LA accreditation no. 2742.01 and the Mutual Recognition Agreement between NATA and A2LA. It is effective from 11 July 2008. RTA status applies only to the following standards and is contingent upon their continued inclusion in your laboratory's scope of accreditation.

**AS/ACIF S002, AS/ACIF S003, AS/ACIF S004,
AS/ACIF S006, AS/ACIF S016, AS/ACIF S031,
AS/ACIF S038, AS/ACIF S041 and
AS/ACIF S043.2**

As an RTA, your laboratory has the following obligations.

1. the laboratory shall continue to meet all of the accreditation criteria of A2LA;
2. the authorised representative of the laboratory shall notify NATA of changes to the staff or operations of the laboratory which would affect the performance of the tests for which the laboratory has been determined;
3. compliance of equipment shall be reported on test reports bearing the A2LA logo/endorsement.

Current information on the Australian Communications and Media Authority and regulatory requirements for telecommunications products within Australia can be obtained from the ACMA's web-site at "<http://www.acma.gov.au>". Further information about NATA may be gained by visiting "<http://www.nata.asn.au>".

Please note that AS/ACIF S040 and New Zealand standards do not form part of the RTA scheme.

Your RTA listing will appear on the NATA website shortly.

Kind Regards

Chris Norton,
Senior Scientific Officer
Measurement Science and Technology
National Association of Testing Authorities (NATA)
71-73 Flemington Road
North Melbourne Vic 3051
Australia
Ph: +61 3 9329 1633 Fx: +61 3 9326 5148
E-Mail: Christopher.Norton@nata.asn.au
Internet: www.nata.asn.au



SIEMIC, INC.

Accessing global markets

Title: RF Test Report Exalt Communications, Inc., model : Radio Module
5 GHz
To FCC 15.407 2011, RSS 210 Issue 8: 2010

Serial# SL12031601-EXA-009R1 rev3.0
Issue Date 13 March 2013
Page 337 of 339
www.siemic.com

SIEMIC ACCREDITATION DETAILS: VCCI Radiated Test Site Registration No. R-3083



VCCI Council

CERTIFICATE

Company: SIEMIC Laboratories
<Member No. 3081 >

Facility: SIEMIC Laboratories
(Radiation 3 meter site)

Location of Facility:
2206 Ringwood Ave , San Jose, CA 95131, USA

*This is to certify that the following measuring facility
has been registered in accordance with the Rules
for Voluntary Control Measures*

Registration No.: R-3083
Date of Registration: October 01 , 2010
This Certificate is valid until September 30 , 2012

VCCI Council



SIEMIC ACCREDITATION DETAILS: VCCI Conducted (Main Port) Test Site Registration No. C-3421



VCCI Council

CERTIFICATE

Company: SIEMIC Laboratories

<Member No. 3081 >

Facility: SIEMIC Laboratories

(Main Ports Conducted Interference Measurement)

Location of Facility:

2206 Ringwood Ave San Jose, CA 95131, USA

*This is to certify that the following measuring facility
has been registered in accordance with the Rules
for Voluntary Control Measures*

Registration No.: C-3421

Date of Registration: October 01 , 2010

This Certificate is valid until September 30 , 2012

VCCI Council





SIEMIC, INC.

Accessing global markets

Title: RF Test Report Exalt Communications, Inc., model : Radio Module
5 GHz
To FCC 15.407 2011, RSS 210 Issue 8: 2010

Serial# SL12031601-EXA-009R1 rev3.0
Issue Date 13 March 2013
Page 339 of 339
www.siemic.com

SIEMIC ACCREDITATION DETAILS: VCCI Conducted (Telecom Port) Test Site Registration No. T-1597

	 VCCI Council
<h1>CERTIFICATE</h1>	
Company: SIEMIC Laboratories <i><Member No. 3081 ></i>	
Facility: SIEMIC Laboratories (Telecommunication Ports Conducted Disturbance Measurement)	
Location of Facility: 2206 Ringwood Ave San Jose, CA 95131, USA	
<i>This is to certify that the following measuring facility has been registered in accordance with the Rules for Voluntary Control Measures</i>	
Registration No.: T-1597 Date of Registration: October 01 , 2010 This Certificate is valid until September 30 , 2012	
	 VCCI Council 