

EXALT COMMUNICATIONS, INC.



5 GHz Radio Module
Model: EX-5i

27 July 2009
Report No.: SL09061401-EXT-004
(This report supersedes: None)



Modifications made to the product : None

This Test Report is Issued Under the Authority of:

	
Choon Sian Ooi Test Engineer	Leslie Bai Engineering Reviewer

This test report may be reproduced in full only.
Test result presented in this test report is applicable to the representative sample only.

EMC Test Report

To: FCC Part 15.247 & RSS210 Issue7: 2007

SIEMIC, INC.
Accessing global markets



Laboratory Introduction

SIEMIC, headquartered in the heart of Silicon Valley, with superior facilities in US and Asia, is one of the leading independent testing and certification facilities providing customers with one-stop shop services for Compliance Testing and Global Certifications.



In addition to [testing](#) and [certification](#), SIEMIC provides initial design reviews and [compliance management](#) through out a project. Our extensive experience with [China](#), [Asia Pacific](#), [North America](#), [European](#), and [international](#) compliance requirements, assures the fastest, most cost effective way to attain regulatory compliance for the [global markets](#).

Accreditations for Conformity Assessment

Country/Region	Accreditation Body	Scope
USA	FCC, A2LA	EMC , RF/Wireless , Telecom
Canada	IC, A2LA, NIST	EMC, RF/Wireless , Telecom
Taiwan	BSMI , NCC , NIST	EMC, RF, Telecom , Safety
Hong Kong	OFTA , NIST	RF/Wireless , Telecom
Australia	NATA, NIST	EMC, RF, Telecom , Safety
Korea	KCC/RRA, NIST	EMI, EMS, RF , Telecom, Safety
Japan	VCCI, JATE, TELEC, RFT	EMI, RF/Wireless, Telecom
Mexico	NOM, COFETEL, Caniety	Safety, EMC , RF/Wireless, Telecom
Europe	A2LA, NIST	EMC, RF, Telecom , Safety

Accreditations for Product Certifications

Country	Accreditation Body	Scope
USA	FCC TCB, NIST	EMC , RF , Telecom
Canada	IC FCB , NIST	EMC , RF , Telecom
Singapore	iDA, NIST	EMC , RF , Telecom



This page has been left blank intentionally.



CONTENTS

1	EXECUTIVE SUMMARY & EUT INFORMATION.....	6
2	TECHNICAL DETAILS.....	7
3	MODIFICATION	8
4	TEST SUMMARY	9
5	MEASUREMENTS, EXAMINATION AND DERIVED RESULTS	10
	ANNEX A. TEST INSTRUMENT & METHOD	23
	ANNEX B EUT AND TEST SETUP PHOTOGRAPHS.....	23
	ANNEX C. TEST SETUP AND SUPPORTING EQUIPMENT	23
	ANNEX D USER MANUAL, BLOCK & CIRCUIT DIAGRAM	23
	ANNEX E SIEMIC ACCREDITATION	23



SIEMIC, Inc.
Accessing global markets

Title: RF Test Report Exalt Communications, Inc., model : EX-5i
To: FCC 15.247 2009, RSS 210 Issue 7: 2007

Serial# SL09061401-EXT-004
Issue Date 27 July 2009
Page 5 of 140
www.siemec.com

This page has been left blank intentionally.



1 Executive Summary & EUT information

The purpose of this test programme was to demonstrate compliance of the Exalt Communications, Inc., 5 GHz Radio Module, and Model: EX-5i against the current Stipulated Standards. The 5 GHz Radio Module have demonstrated compliance with the FCC 15.247 2009.

EUT Information

**EUT
Description**

: The unlicensed products are fixed point-to-point radio operating in the 5725-5850 MHz bands. Two units, combined with external antennas and transmission lines, make up a complete point-to-point link. Users connect Ethernet and/or time division multiplexed (TDM) signals (T1, E1 or DS3) to carry bi-directional traffic across the link in place of traditional copper wires or fiber. The system utilizes time division duplex (TDD) radio transmission, and provides the administrator selection between one of three modulation modes, and one of four occupied bandwidths. The administrator may also select the specific operating center frequency across a frequency range that is defined by the limits of the selected occupied bandwidth. The output power may be adjusted by the installer in accordance to the connected transmission system and the specific regulations or link design. The radio is connected to a flat panel or parabolic dish antenna with coaxial transmission line, or in some cases, elliptical waveguide. The transmission system is grounded, along with any lightning arrestors that may be placed at any cable egress points. The radio is typically mounted in a grounded equipment rack, or on a table top or wall-mounted, and is connected to DC power, via either direct DC source or AC/DC converter, with power grounding, as required. The user's services (T1, E1, DS3, Ethernet) are directly connected, along with any diagnostic equipment. The radio chassis has a separate grounding connector, if required for separate chassis grounding.

Model No : EX-5i

Input Power : 120 Vac

**Classification
Per Stipulated
Test Standard** : Spread Spectrum System / Device



2 TECHNICAL DETAILS

Purpose	Compliance testing of 5 GHz Radio Module with stipulated standard
Applicant / Client	Exalt Communications, Inc.
Manufacturer	Exalt Communications, Inc. 580 Division Street Campbell, California 95008 USA
Laboratory performing the tests	SIEMIC Laboratories
Test report reference number	SL09061401-EXT-004
Date EUT received	09 July 2009
Standard applied	47 CFR §15.247 (2009)
Dates of test (from – to)	July 10-21 2009
No of Units:	1
Equipment Category:	DTS
Trade Name:	Exalt Communications, Inc.
Model :	EX-5i
RF Operating Frequency (ies)	5745 to 5825 MHz
Channel Bandwidth:	8MHz Channel Bandwidth, 16MHz Channel Bandwidth, 32MHz Channel Bandwidth
Modulation :	Mode 1:QPSK, Mode 2:16QAM, Mode 3:64QAM
FCC ID :	TTM-105P25N
IC ID :	6254A-105P25N



3 MODIFICATION

NONE

4 TEST SUMMARY

The product was tested in accordance with the following specifications. All Testing has been performed according to below product classification:

Spread Spectrum System / Device

Test Results Summary

Test Standard		Description	Pass / Fail
CFR 47 Part 15.247: 2009	RSS 210 Issue 7: 2007		
15.203		Antenna Requirement	Pass
15.205	RSS210(A8.5)	Restricted Band of Operation	Pass
15.207(a)	RSSGen(7.2.2)	Conducted Emissions Voltage	Pass
15.247(a)(1)	RSS210(A8.1)	Channel Separation	N/A
15.247(a)(1)	RSS210(A8.1)	Occupied Bandwidth	Pass
15.247(a)(2)	RSS210 (A8.2)	Bandwidth	Pass
15.247(a)(1)	RSS210(A8.1)	Number of Hopping Channels	N/A
15.247(a)(1)	RSS210(A8.1)	Time of Occupancy	N/A
15.247(b)	RSS210(A8.4)	Output Power	Pass
15.247(c)	RSS210(A8.4)	Antenna Gain > 6 dBi	Pass
15.247(d)	RSS210(A8.5)	Conducted Spurious Emissions	Pass
15.209; 15.247(d)	RSS210(A8.5)	Radiated Spurious Emissions	Pass
15.247(e)	RSS210(A8.3)	Power Spectral Density	Pass
15.247(f)	RSS210(A8.3)	Hybrid System Requirement	N/A
15.247(g)	RSS210(A8.1)	Hopping Capability	N/A
15.247(h)	RSS210(A8.1)	Hopping Coordination Requirement	N/A
15.247(i)	RSSGen(5.5)	RF Exposure requirement	Pass
	RSSGen(4.8)	Receiver Spurious Emissions	Pass

ANSI C63.4: 2003/ RSS-Gen Issue 2: 2007

PS: All measurement uncertainties are not taken into consideration for all presented test result.

5 MEASUREMENTS, EXAMINATION AND DERIVED RESULTS

5.1 Antenna Requirement

Requirement(s): 47 CFR §15.203

An intentional radiator shall be designed to ensure that no antenna other than that furnished by the responsible party shall be used with the device.

Antenna requirement must meet at least one of the following:

- a) Antenna must be permanently attached to the device.
- b) Antenna must use a unique type of connector to attach to the device.
- c) Device must be professionally installed. Installer shall be responsible for ensuring that the correct antenna is employed with the device.

The device must be professionally installed. Installer shall be responsible for ensuring that the correct antenna is employed with the device.

Antenna Model: SP6-5GHz

5.2 Conducted Emissions Voltage

Requirement :

Frequency of emission (MHz)	Conducted limit (dBµV)	
	Quasi-peak	Average
0.15–0.5	66 to 56*	56 to 46*
0.5–5	56	46
5–30	60	50

*Decreases with the logarithm of the frequency.

Procedures:

- All possible modes of operation were investigated. Only the 6 worst case emissions measured, using the correct CISPR and Average detectors, are reported. All other emissions were relatively insignificant.
- A "-ve" margin indicates a PASS as it refers to the margin present below the limit line at the particular frequency.
- Conducted Emissions Measurement Uncertainty
All test measurements carried out are traceable to national standards. The uncertainty of the measurement at a confidence level of approximately 95% (in the case where distributions are normal), with a coverage factor of 2, in the range 9kHz – 30MHz (Average & Quasi-peak) is ±3.5dB.
- Environmental Conditions

Temperature	23°C
Relative Humidity	50%
Atmospheric Pressure	1019mbar

Test Date : July 10-21 2009

Tested By :Choon Sian Ooi

Results:

Results:

Note: 2

Average Limit

Quasi-Peak Limit

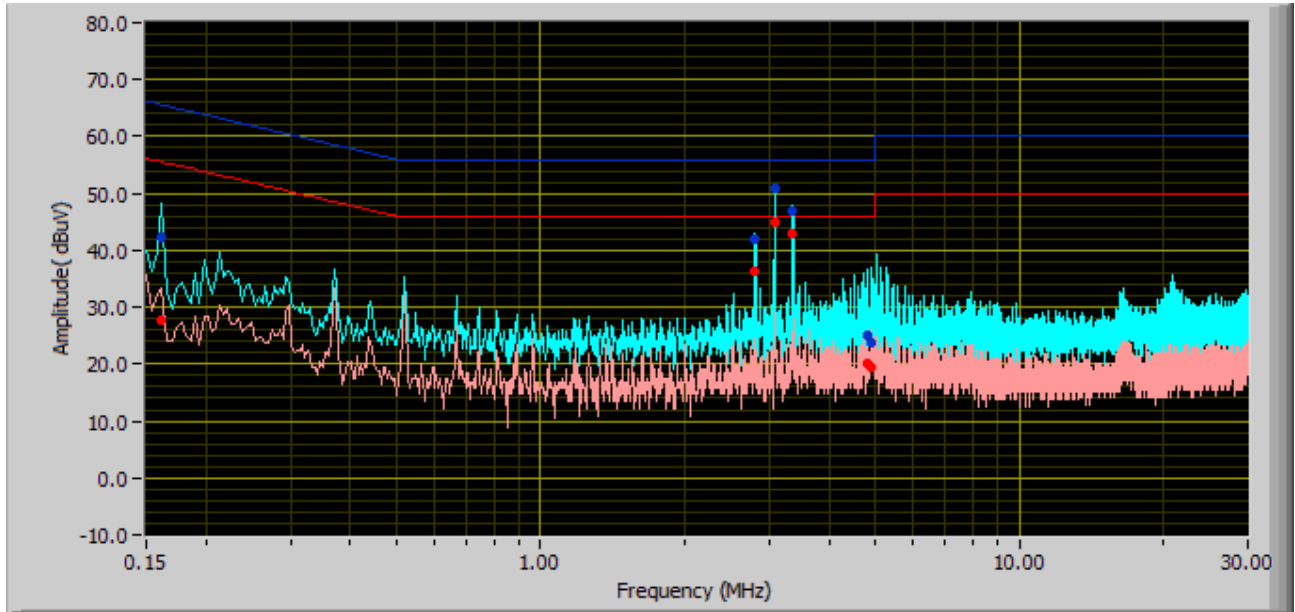

Phase Line Plot at 120Vac, 60Hz

Line Under Test	Frequency (MHz)	Corrected Amplitude (dBuV) QP	Limit (dBuV) QP	Margin (dB) QP	Corrected Amplitude (dBuV) AVG	Limit (dBuV) AVG	Margin (dB) AVG
Phase	3.09	50.80	56.00	-5.20	45.88	46.00	-0.12
Phase	3.37	47.03	56.00	-8.97	43.09	46.00	-2.91
Phase	2.80	42.09	56.00	-13.91	36.44	46.00	-9.56
Phase	0.16	42.22	65.54	-23.32	27.83	55.54	-27.71
Phase	4.89	23.89	56.00	-32.11	19.58	46.00	-26.42
Phase	4.81	24.96	56.00	-31.04	20.18	46.00	-25.82

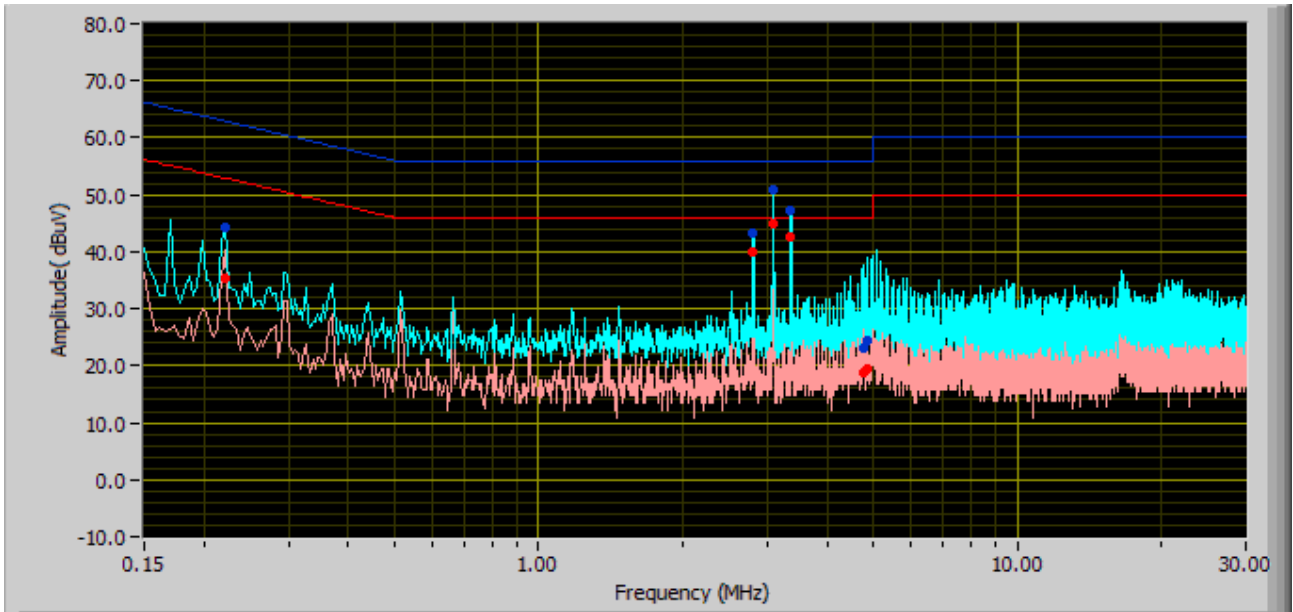

Neutral Line Plot at 120Vac, 60Hz

Line Under Test	Frequency (MHz)	Corrected Amplitude (dBuV) QP	Limit (dBuV) QP	Margin (dB) QP	Corrected Amplitude (dBuV) AVG	Limit (dBuV) AVG	Margin (dB) AVG
Neutral	3.09	50.74	56.00	-5.26	45.88	46.00	-0.12
Neutral	3.37	47.39	56.00	-8.61	42.70	46.00	-3.30
Neutral	2.81	43.19	56.00	-12.81	39.99	46.00	-6.01
Neutral	4.86	24.26	56.00	-31.74	19.58	46.00	-26.42
Neutral	0.22	44.25	62.87	-18.62	35.22	52.87	-17.65
Neutral	4.79	23.10	56.00	-32.90	18.94	46.00	-27.06

5.3 6dB & 99% Occupied Bandwidth

1. Conducted Measurement
 EUT was set for low , mid, high channel with modulated mode and highest RF output power.
 The spectrum analyzer was connected to the antenna terminal.
2. Environmental Conditions

Temperature	23°C
Relative Humidity	50%
Atmospheric Pressure	1019mbar
3. Conducted Emissions Measurement Uncertainty
 All test measurements carried out are traceable to national standards. The uncertainty of the measurement at a confidence level of approximately 95% (in the case where distributions are normal), with a coverage factor of 2, in the range 30MHz – 40GHz is ±1.5dB.
4. Test Date : July 10-21 2009
 Tested By :Choon Sian Ooi

Requirement(s): 47 CFR §15.247(a)(1) ; RSS210(A8.1)

Procedures: The 6dB bandwidths were measured conducted using a spectrum analyzer at low, mid, and hi channels. 6 dB Bandwidth Limit: > 500 kHz.

Mode: 1 = QPSK Mode: 2 = 16QAM Mode: 3 = 64QAM

Channel	Channel Bandwidth	Chain	6 dB Channel Bandwidth (MHz)	99% Channel Bandwidth (MHz)	6 dB Occupied Bandwidth Limit (KHz)
Low Channel	8MHz	1	7.25	7.833	500
	8MHz	2	7.33	8.00	500
	8MHz	3	7.29	7.92	500
Mid Channel	8MHz	1	7.13	7.75	500
	8MHz	2	7.38	8.00	500
	8MHz	3	7.33	8.00	500
High Channel	8MHz	1	7.13	7.79	500
	8MHz	2	7.29	7.92	500
	8MHz	3	7.25	7.96	500

Channel	Channel Bandwidth	Mode	6 dB Channel Bandwidth (MHz)	99% Channel Bandwidth (MHz)	6 dB Occupied Bandwidth Limit (KHz)
Low Channel	16MHz	1	14.08	15.58	500
	16MHz	2	14.58	14.58	500
	16MHz	3	14.50	15.83	500
Mid Channel	16MHz	1	14.08	15.58	500
	16MHz	2	14.58	16.00	500
	16MHz	3	14.58	16.00	500
High Channel	16MHz	1	14.17	15.58	500
	16MHz	2	14.50	15.42	500
	16MHz	3	14.67	15.58	500

Channel	Channel Bandwidth	Mode	6 dB Channel Bandwidth (MHz)	99% Channel Bandwidth (MHz)	6 dB Occupied Bandwidth Limit (KHz)
Low Channel	32MHz	1	29.5	31.5	500
	32MHz	2	29.5	31.3	500
	32MHz	3	29.2	31.7	500
Mid Channel	32MHz	1	29.5	31.3	500
	32MHz	2	29.2	31.5	500
	32MHz	3	29.8	31.5	500
High Channel	32MHz	1	28.7	31.2	500
	32MHz	2	29.5	31.2	500
	32MHz	3	29.2	31.2	500

Refer to the attached plots.

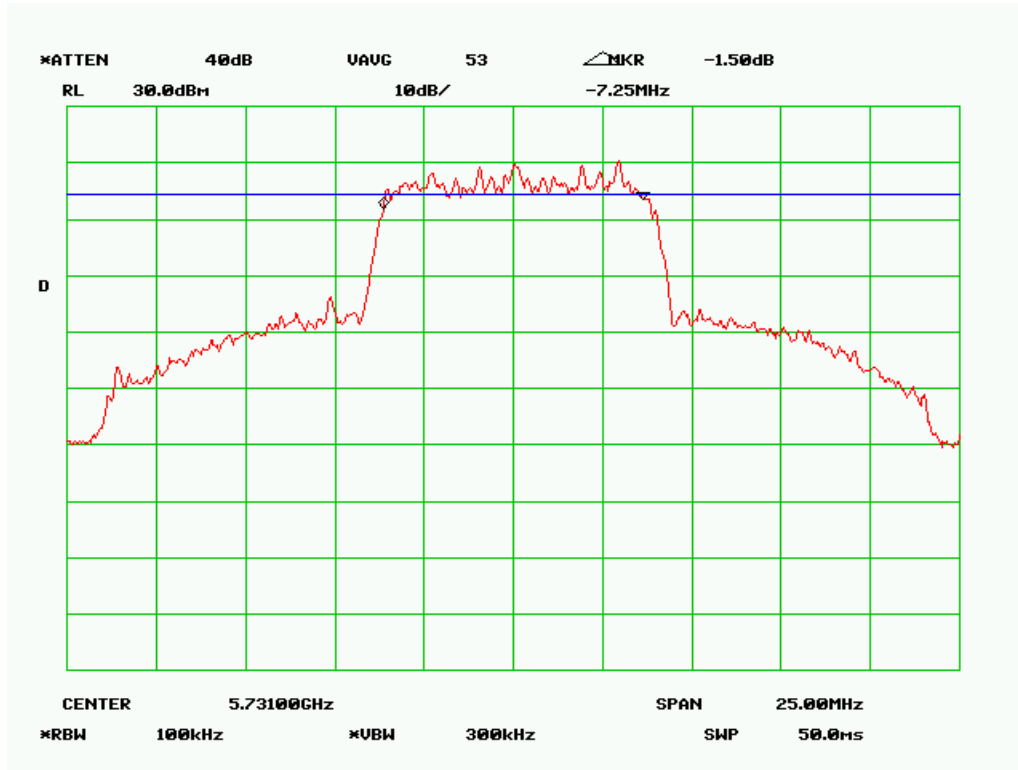

6 dB Bandwidth - Low Channel (8MHz Mode 1)

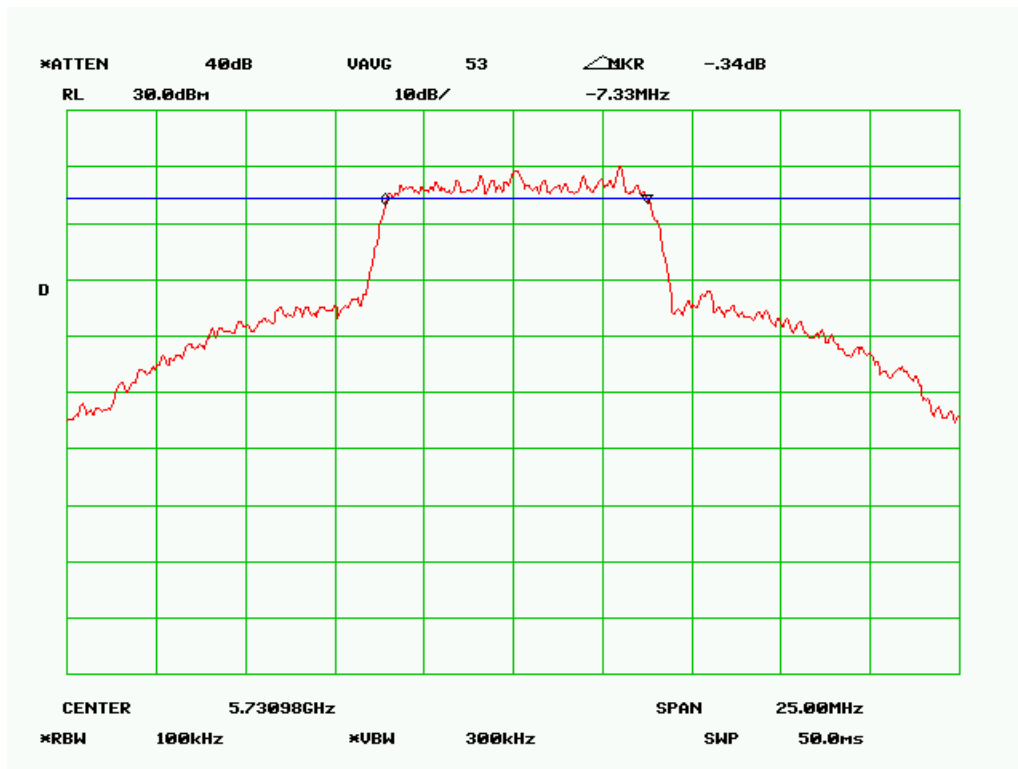

6 dB Bandwidth - Low Channel (8MHz Mode 2)

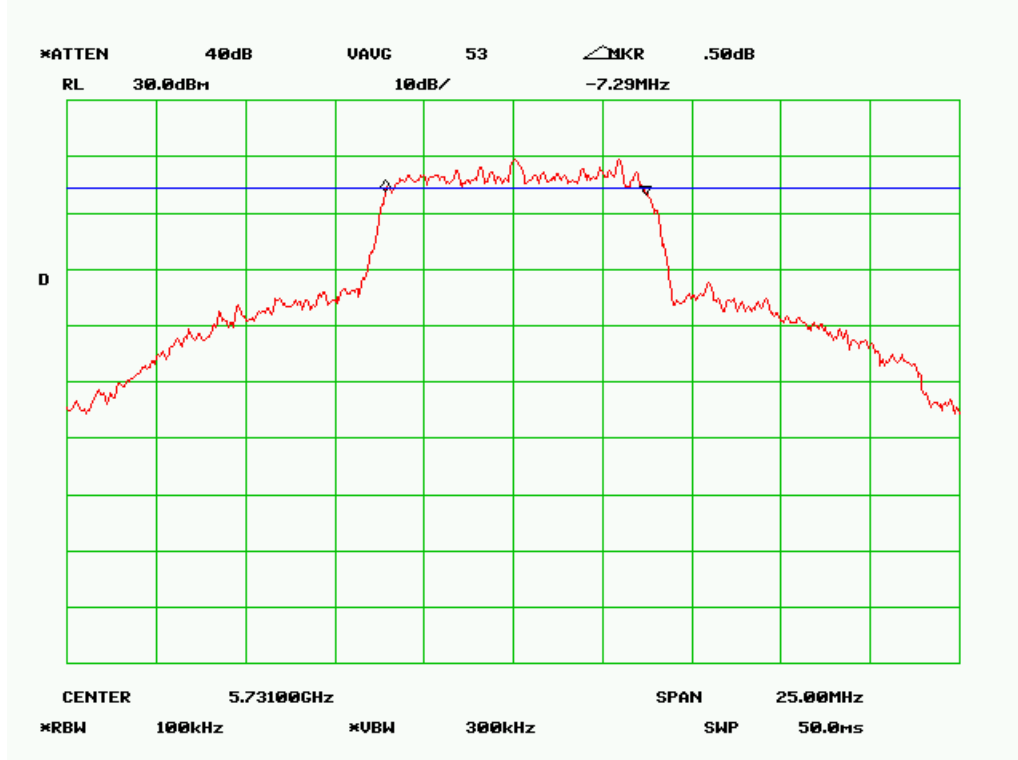

6 dB Bandwidth – Low Channel (8MHz Mode 3)

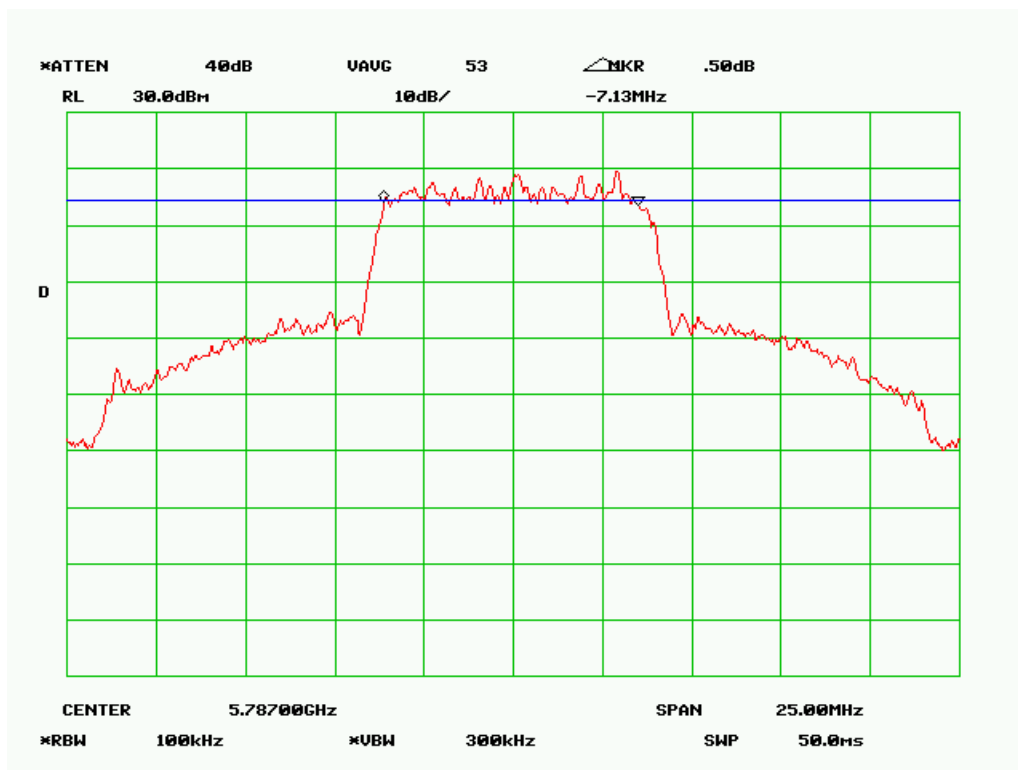

6 dB Bandwidth – Mid Channel (8MHz Mode 1)

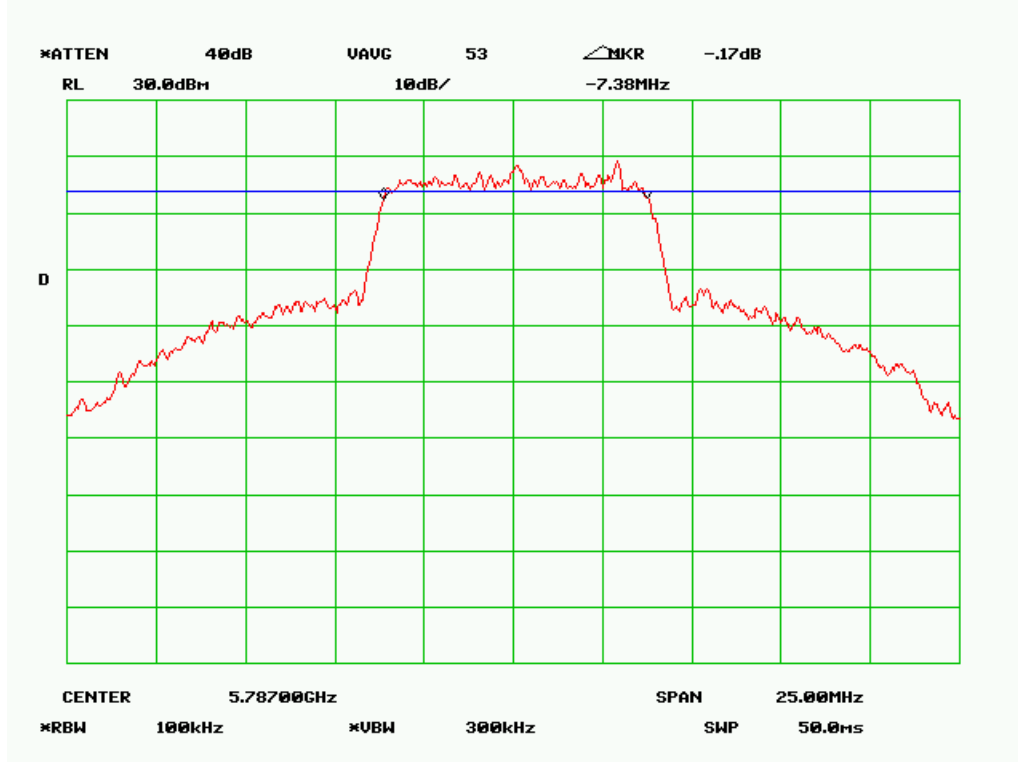

6 dB Bandwidth – Mid Channel (8MHz Mode 2)

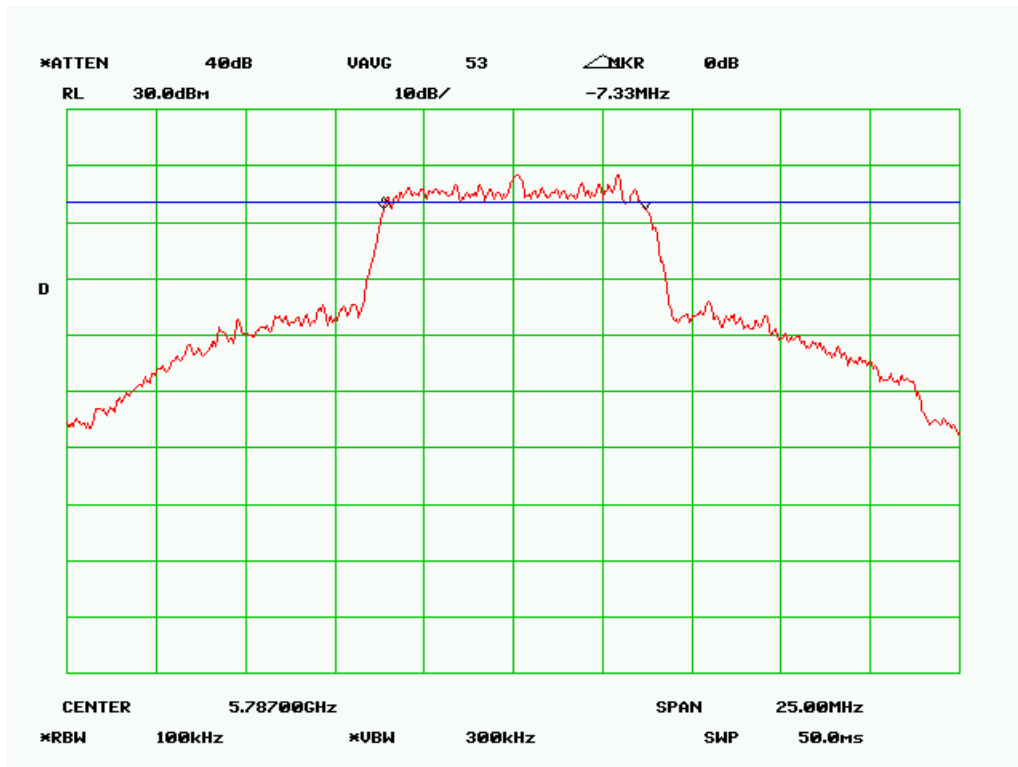

6 dB Bandwidth – Mid Channel (8MHz Mode 3)

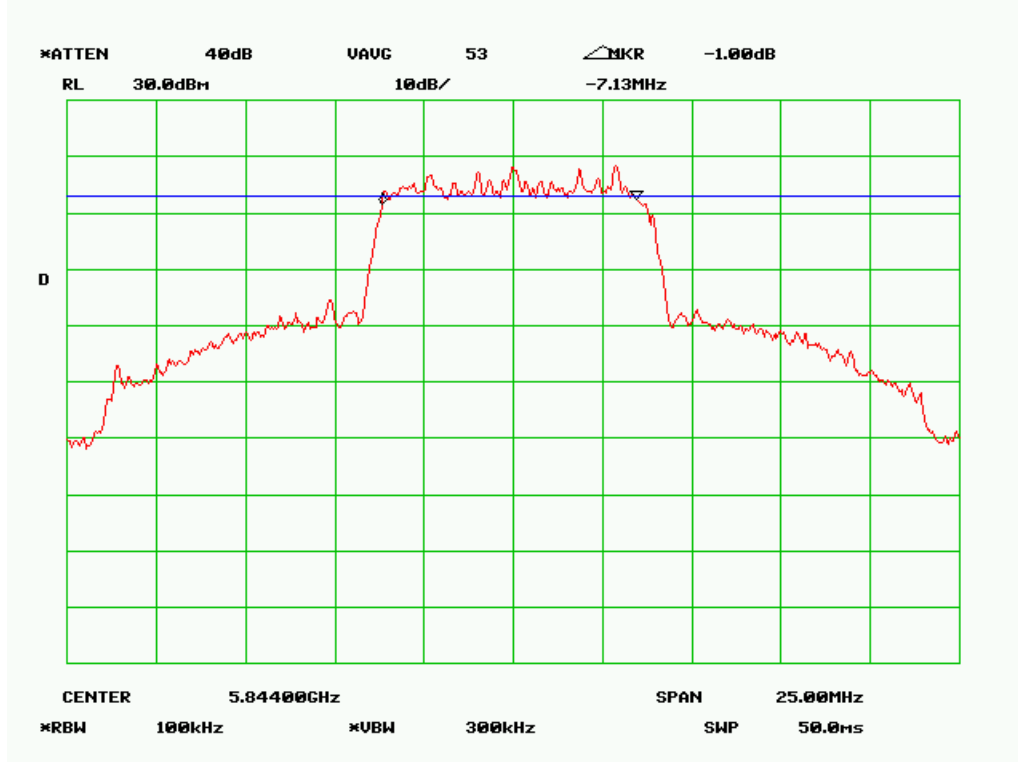

6 dB Bandwidth – High Channel (8MHz Mode 1)

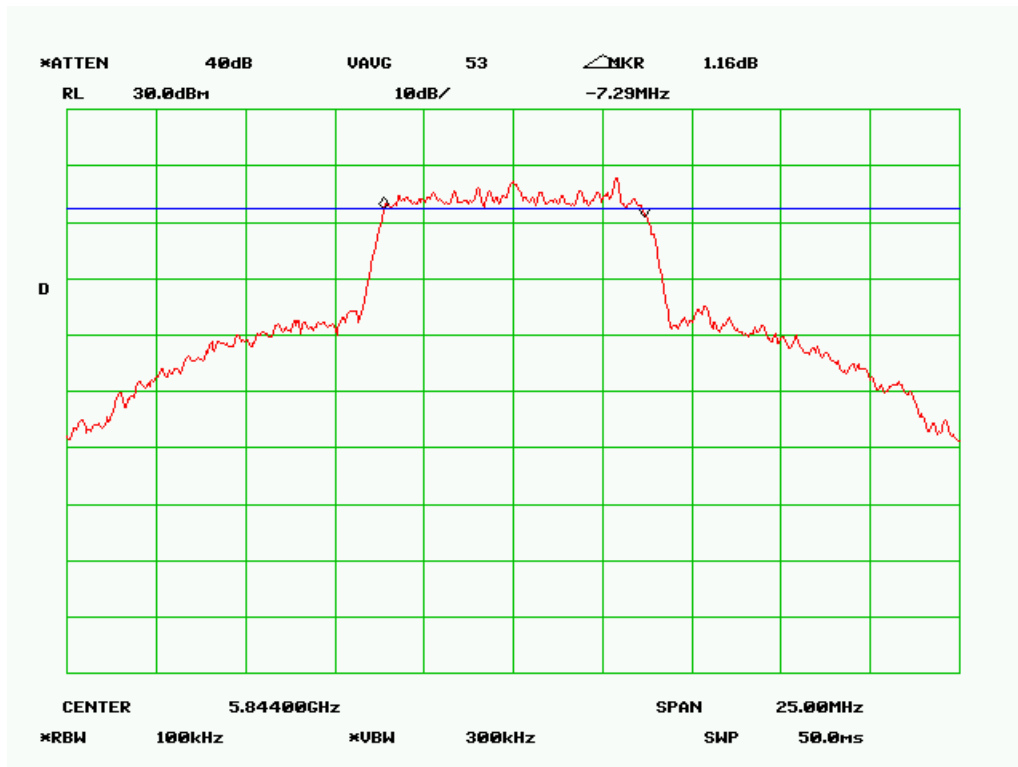

6 dB Bandwidth – High Channel (8MHz Mode 2)

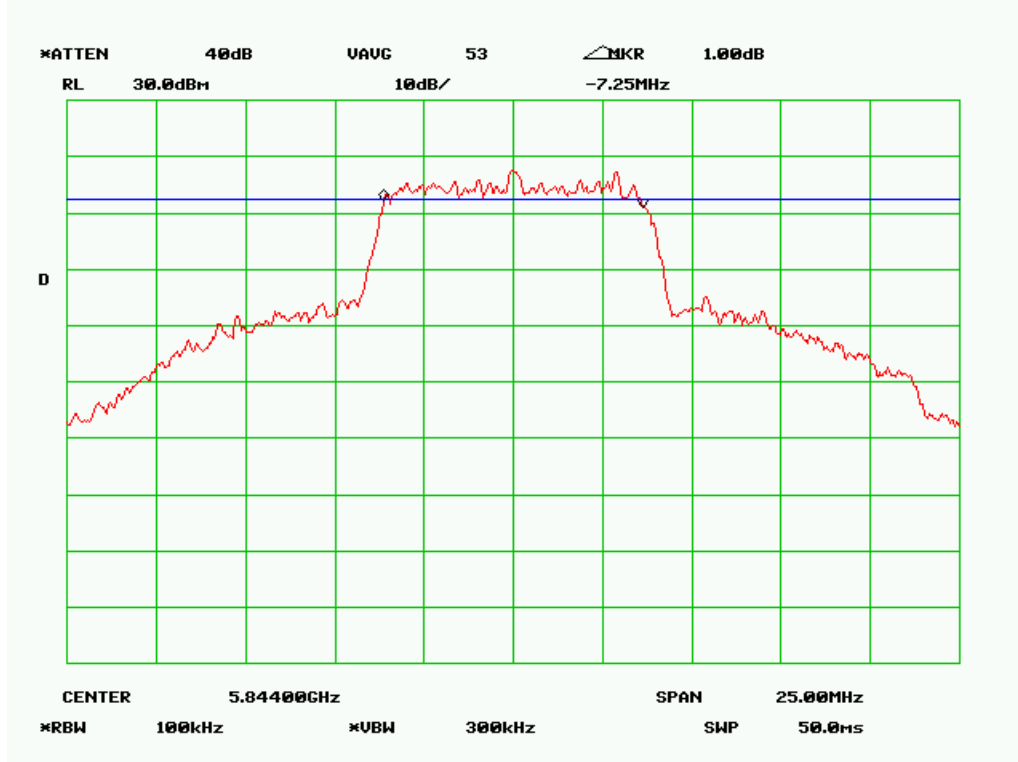

6 dB Bandwidth – High Channel (8MHz Mode 3)

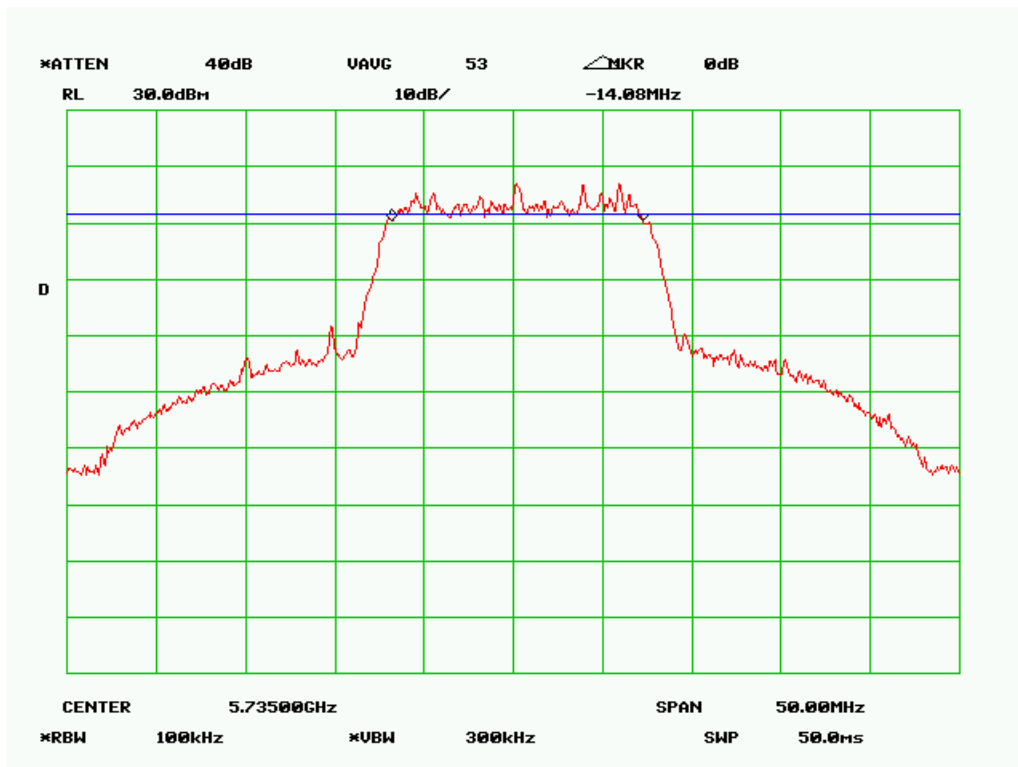

6 dB Bandwidth – Low Channel (16MHz Mode 1)

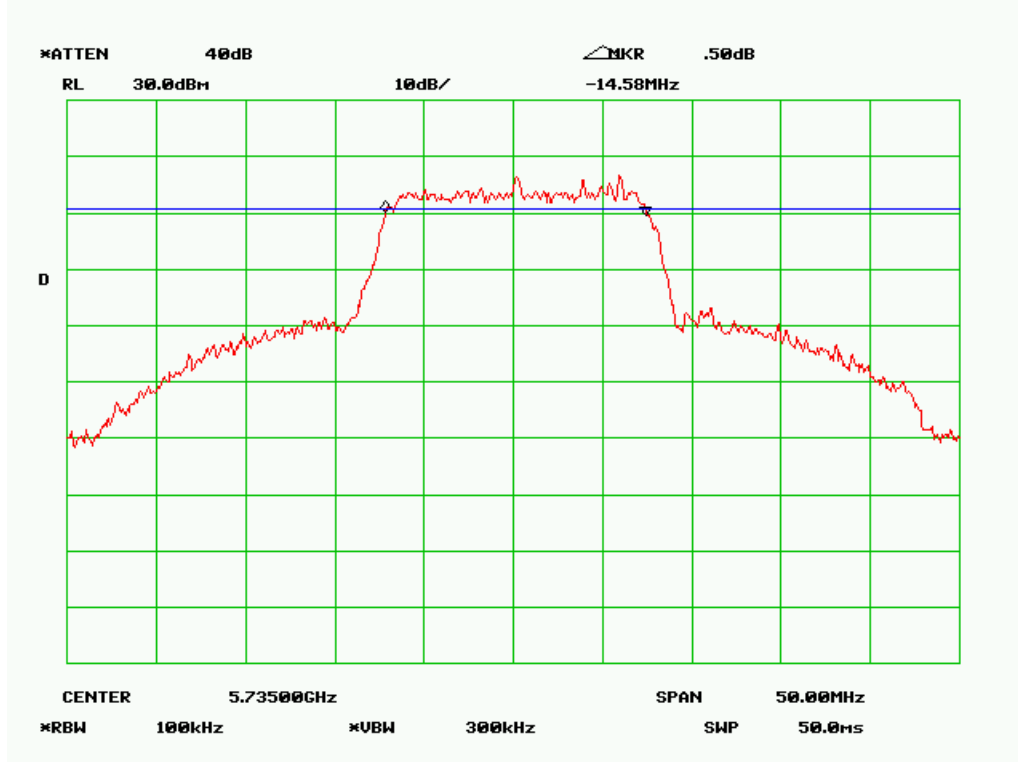

6 dB Bandwidth – Low Channel (16MHz Mode 2)

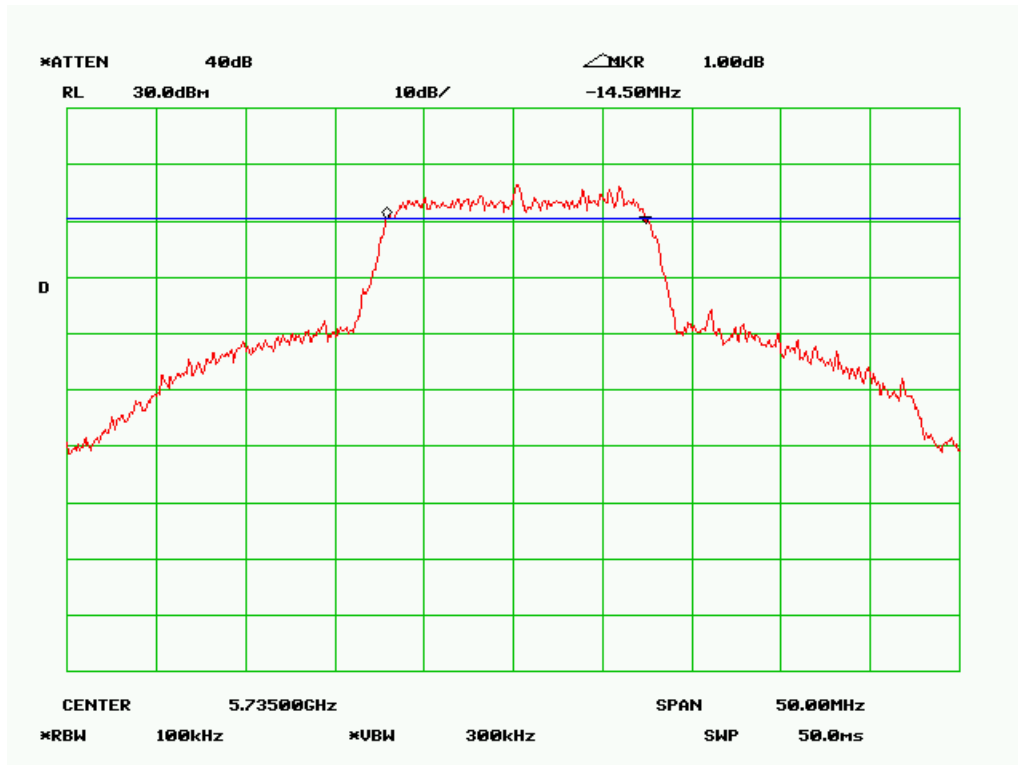

6 dB Bandwidth – Low Channel (16MHz Mode 3)

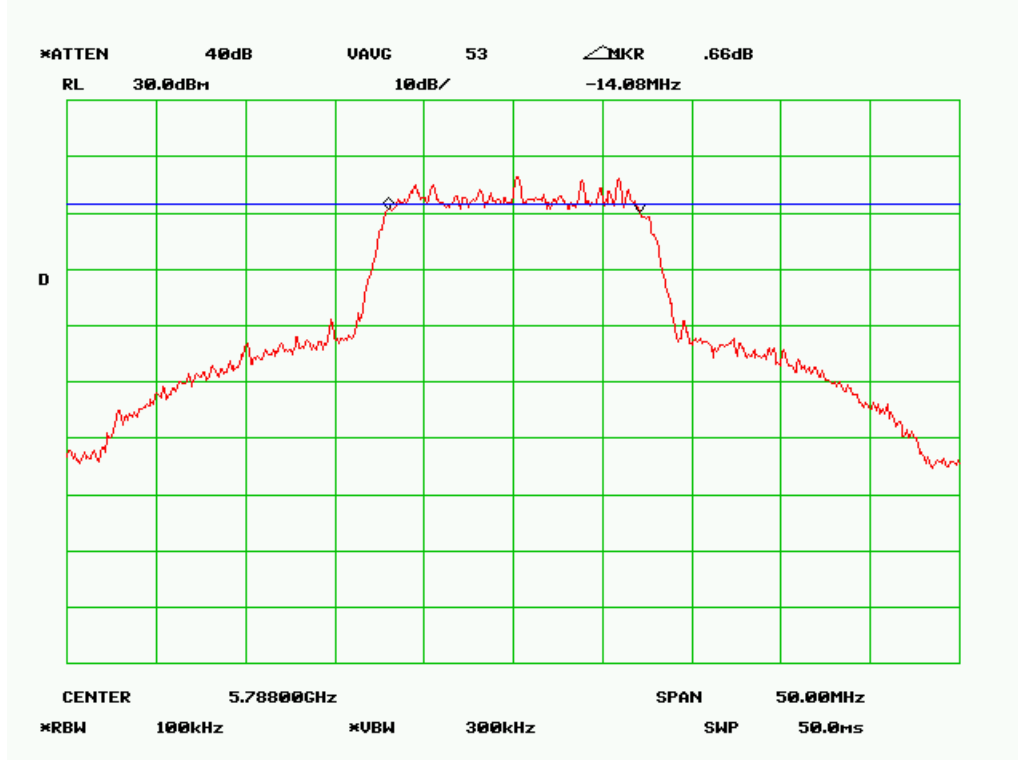

6 dB Bandwidth – Mid Channel (16MHz Mode 1)

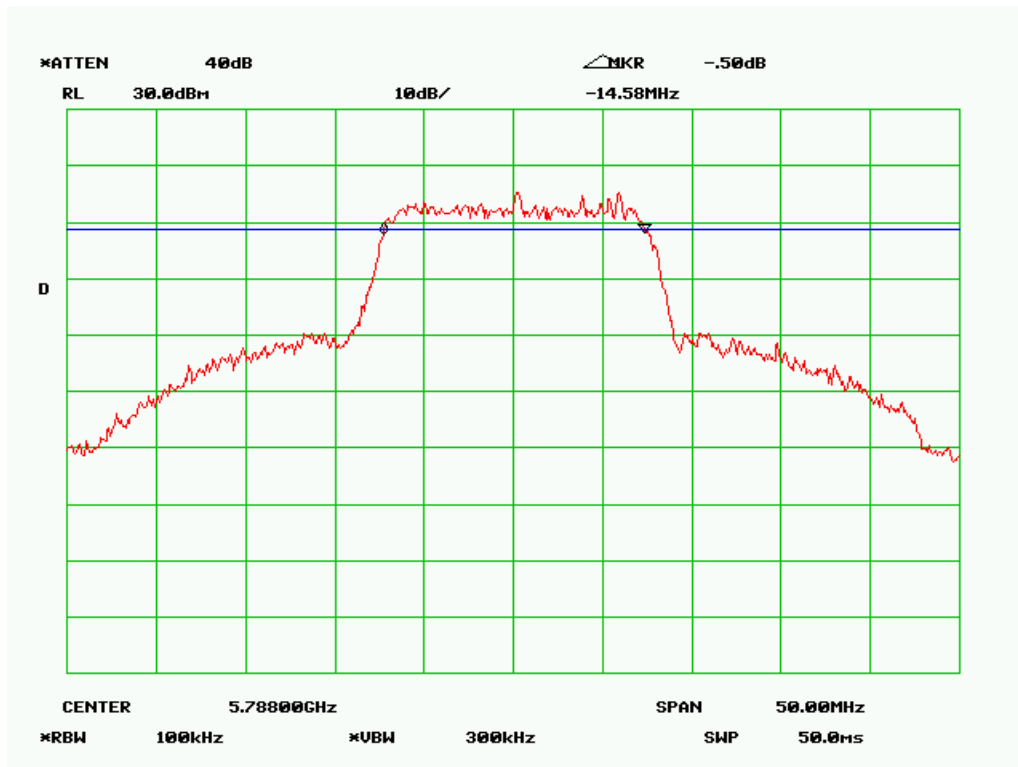

6 dB Bandwidth – Mid Channel (16MHz Mode 2)

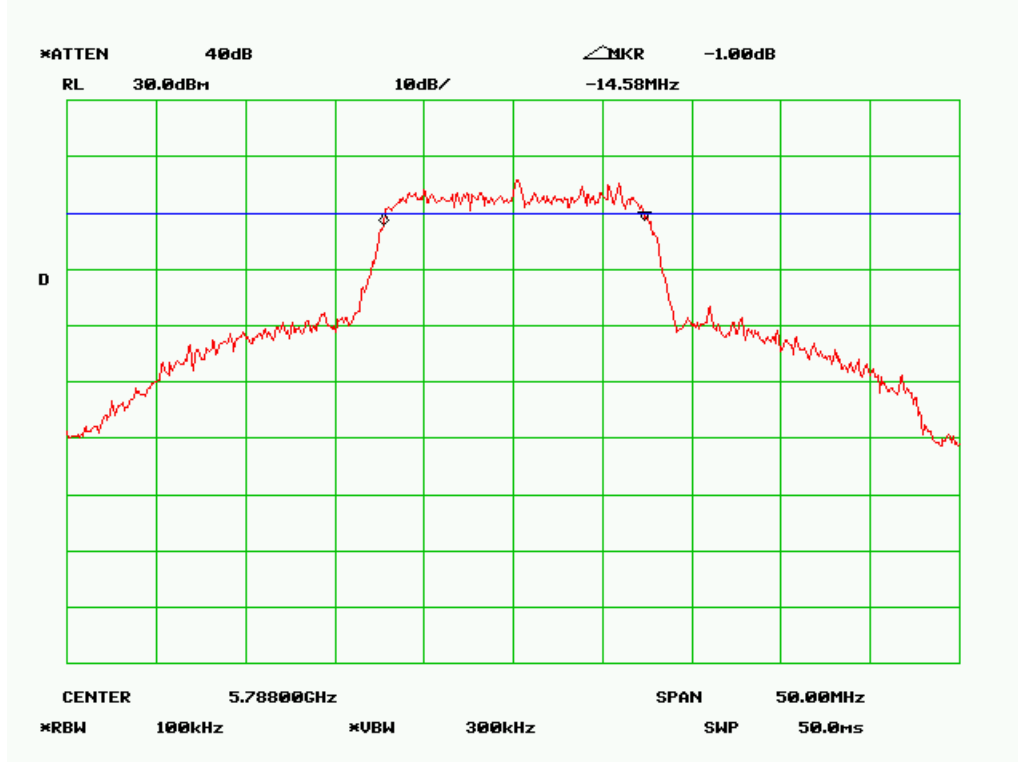

6 dB Bandwidth – Mid Channel (16MHz Mode 3)

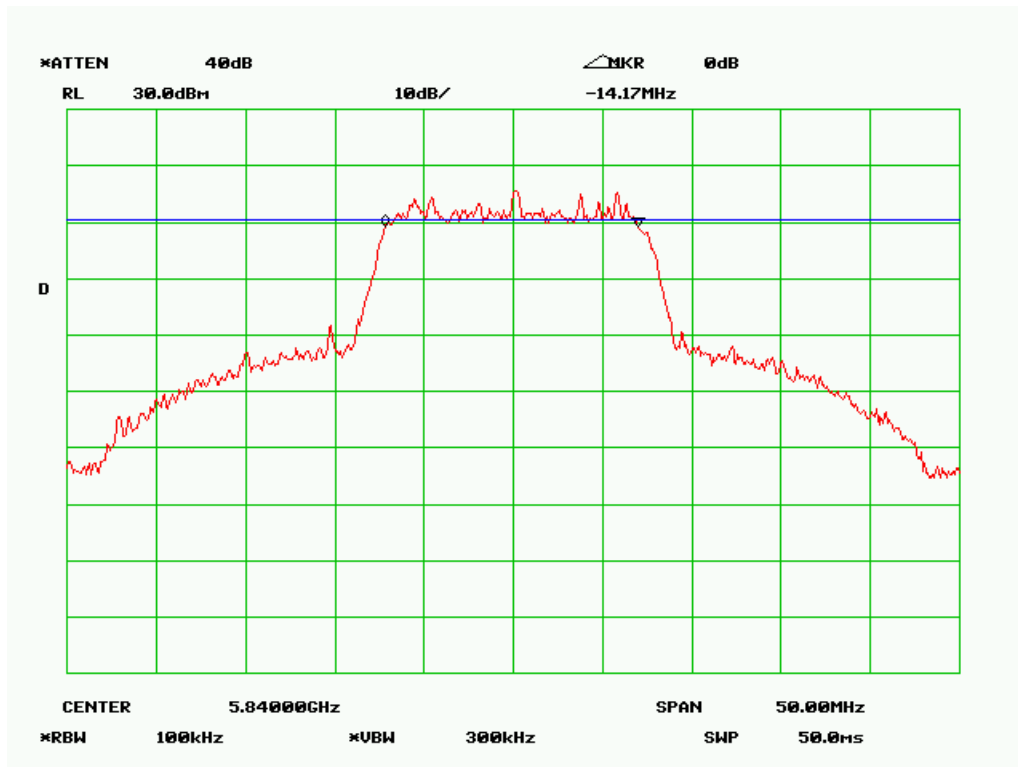

6 dB Bandwidth – High Channel (16MHz Mode 1)

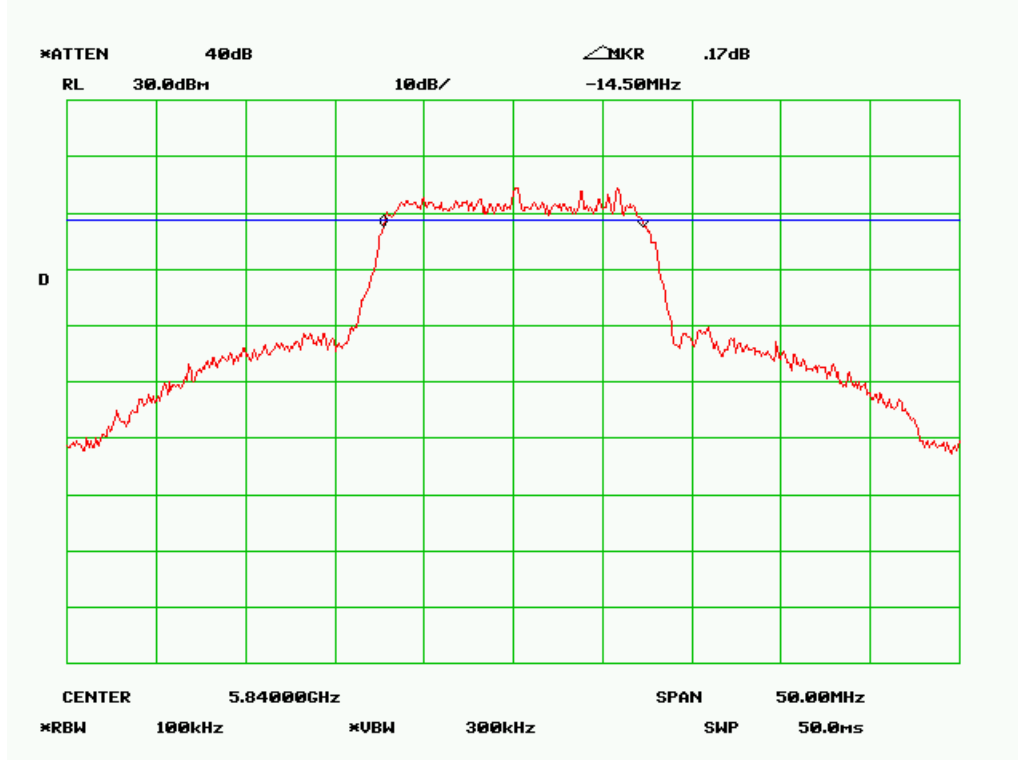

6 dB Bandwidth – High Channel (16MHz Mode 2)

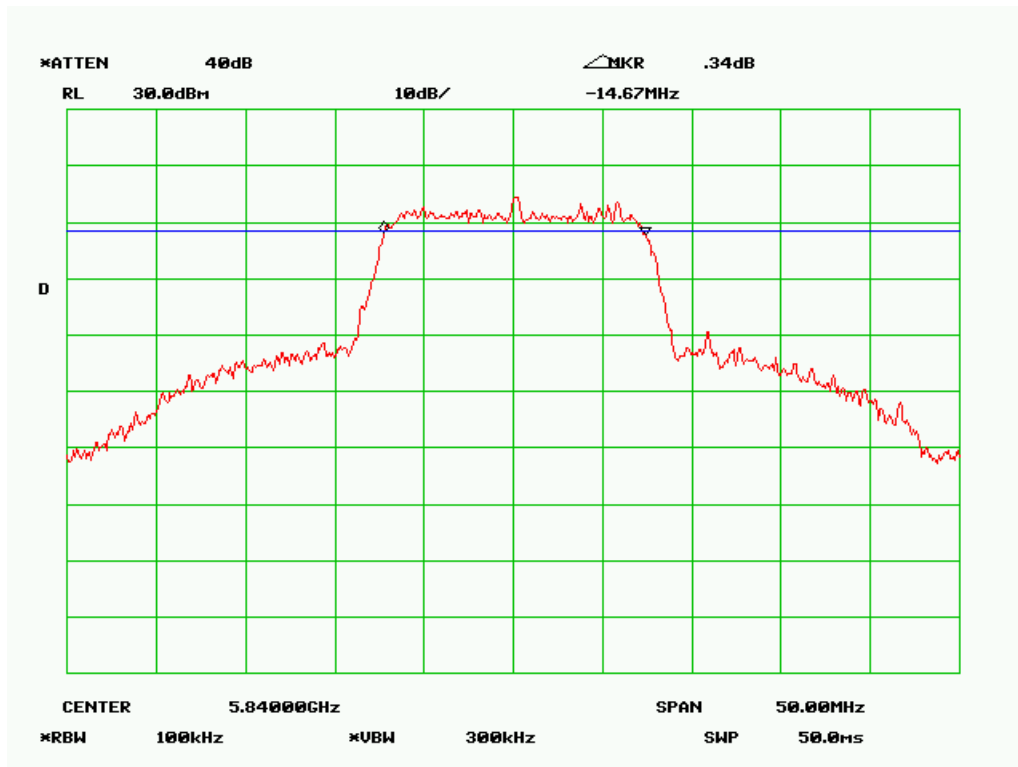

6 dB Bandwidth – High Channel (16MHz Mode 3)

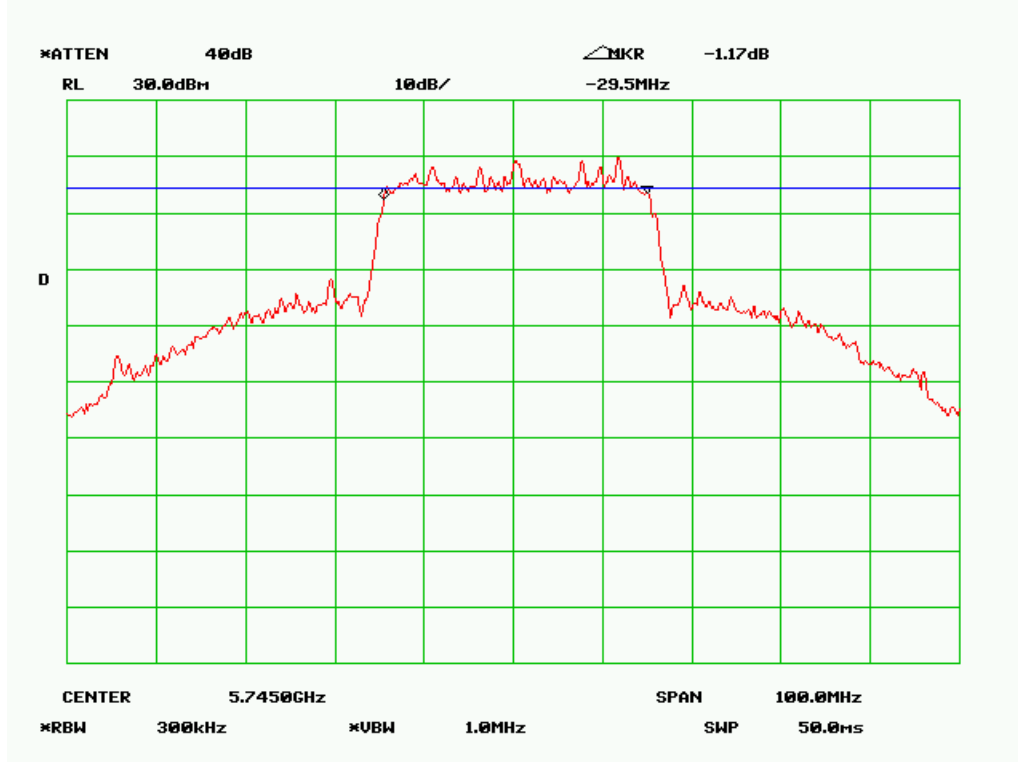

6 dB Bandwidth – Low Channel (32MHz Mode 1)

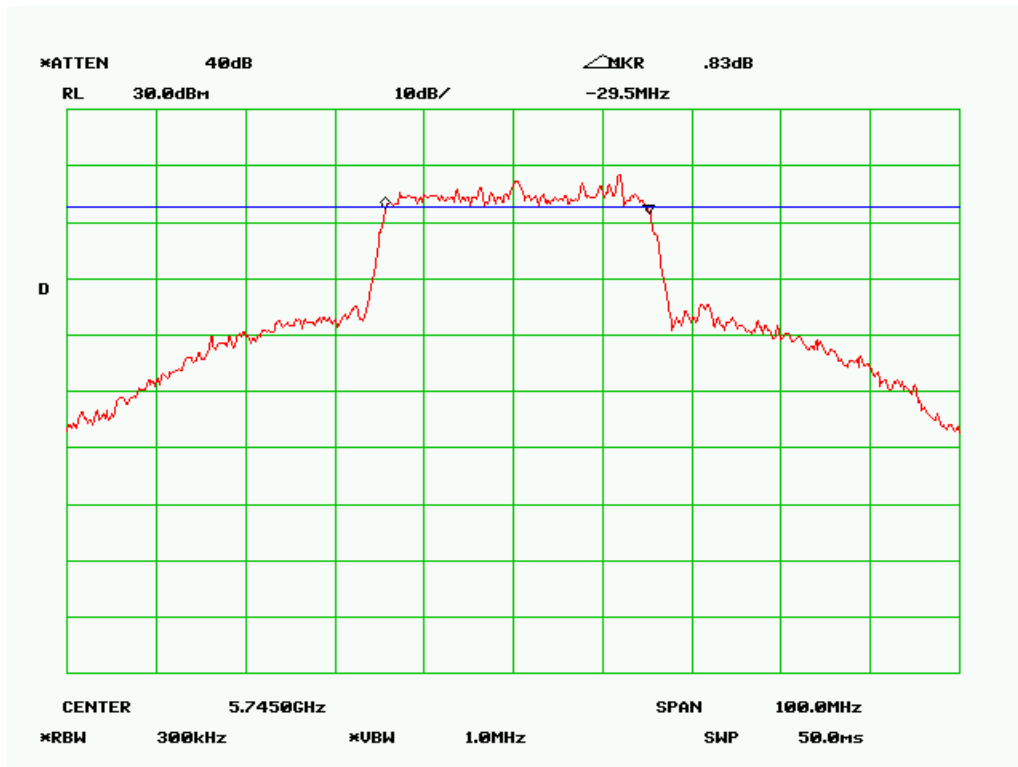

6 dB Bandwidth – Low Channel (32MHz Mode 2)

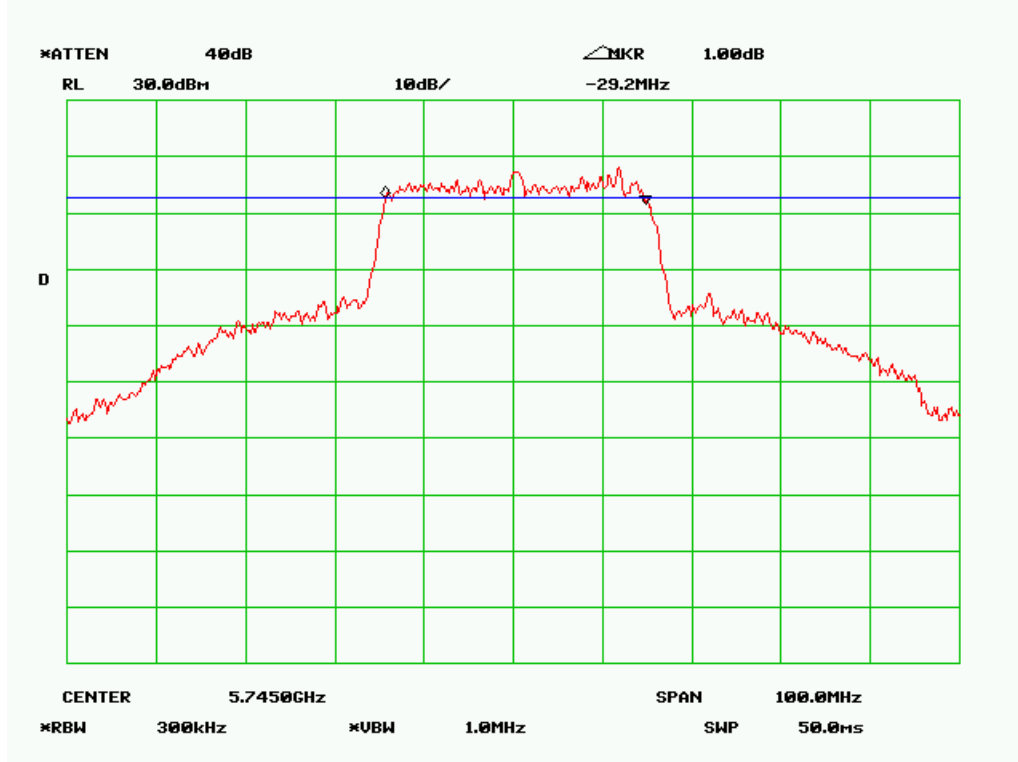

6 dB Bandwidth – Low Channel (32MHz Mode 3)

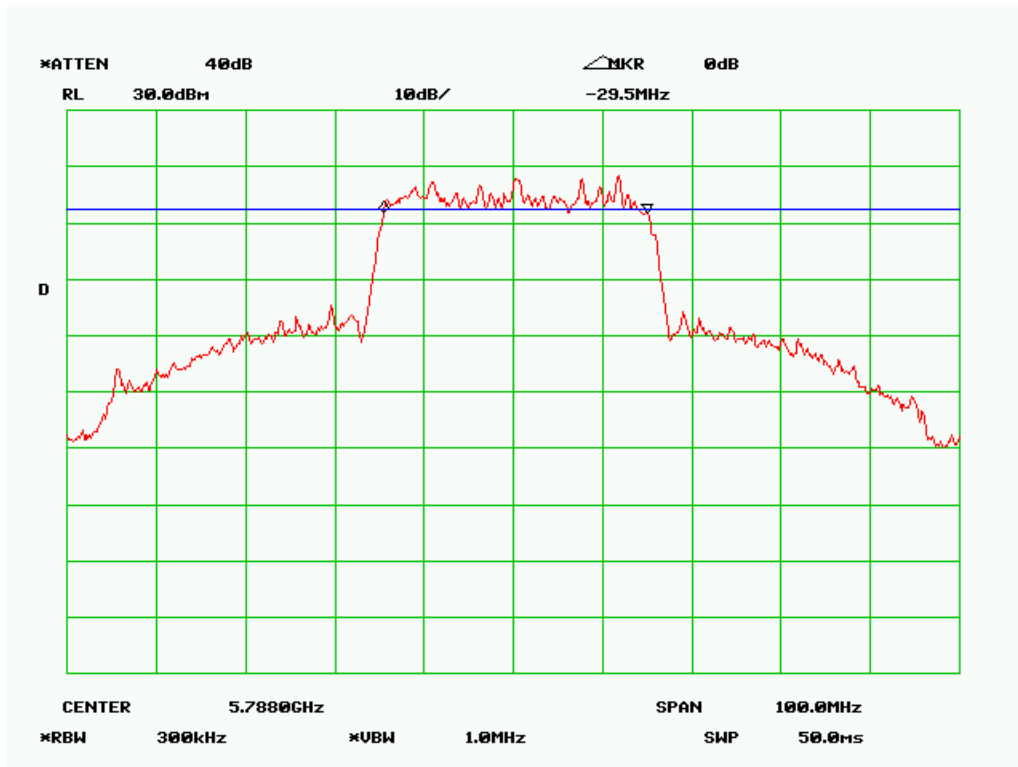

6 dB Bandwidth – Mid Channel (32MHz Mode 1)

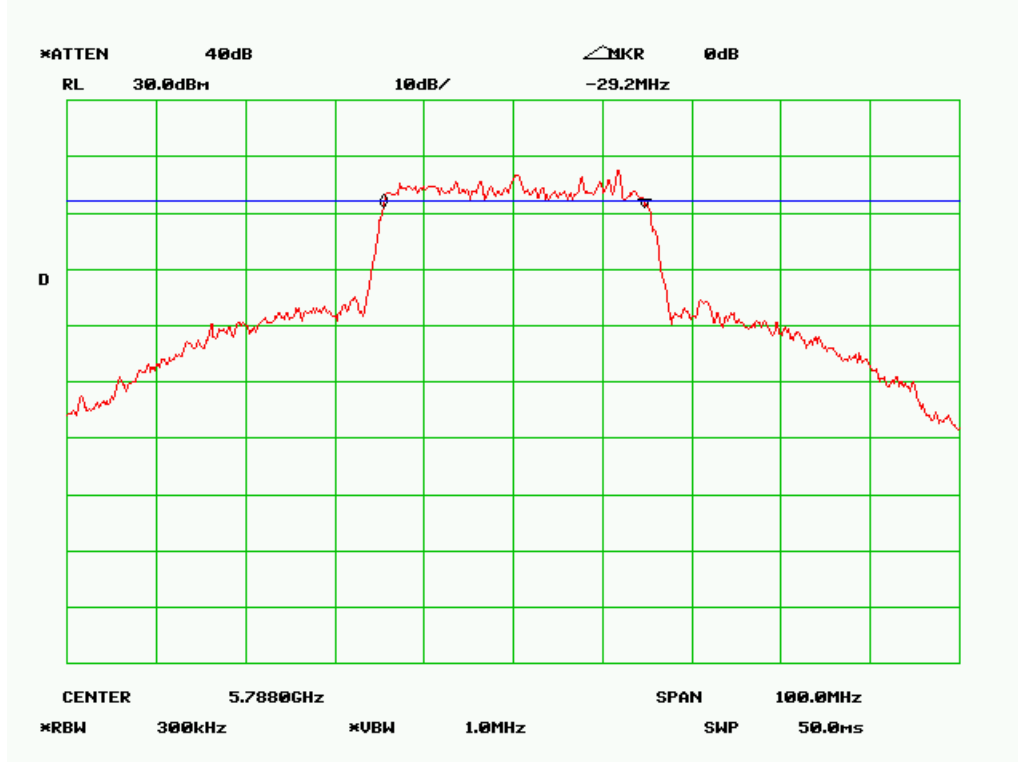

6 dB Bandwidth – Mid Channel (32MHz Mode 2)

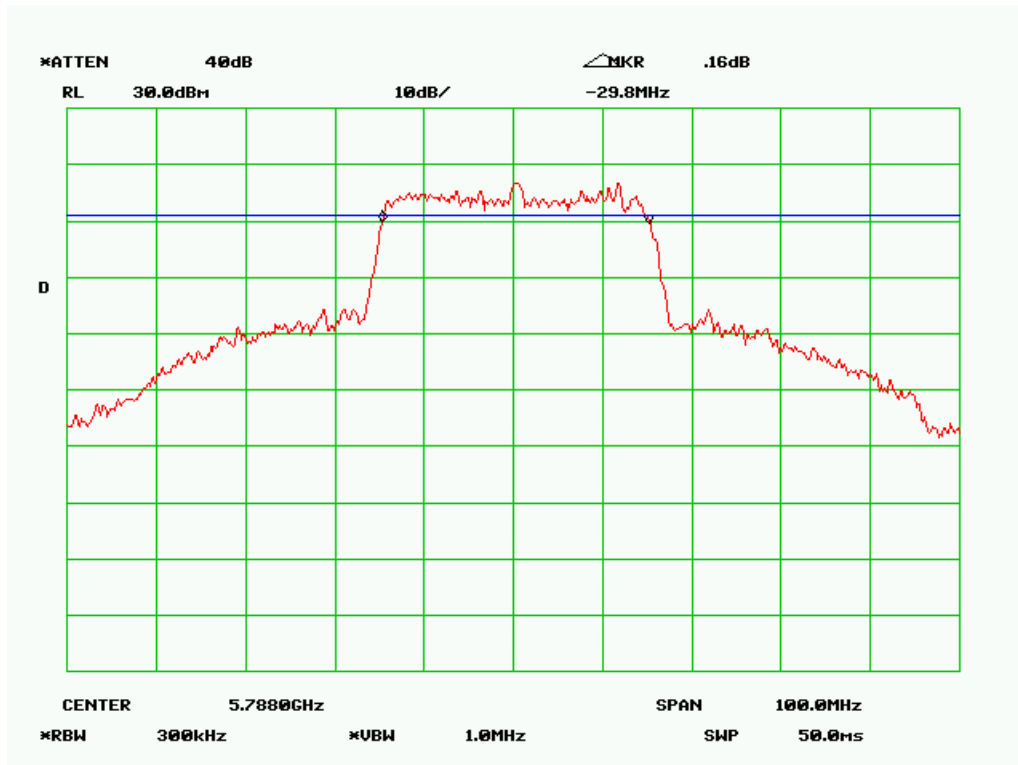

6 dB Bandwidth – Mid Channel (32MHz Mode 3)

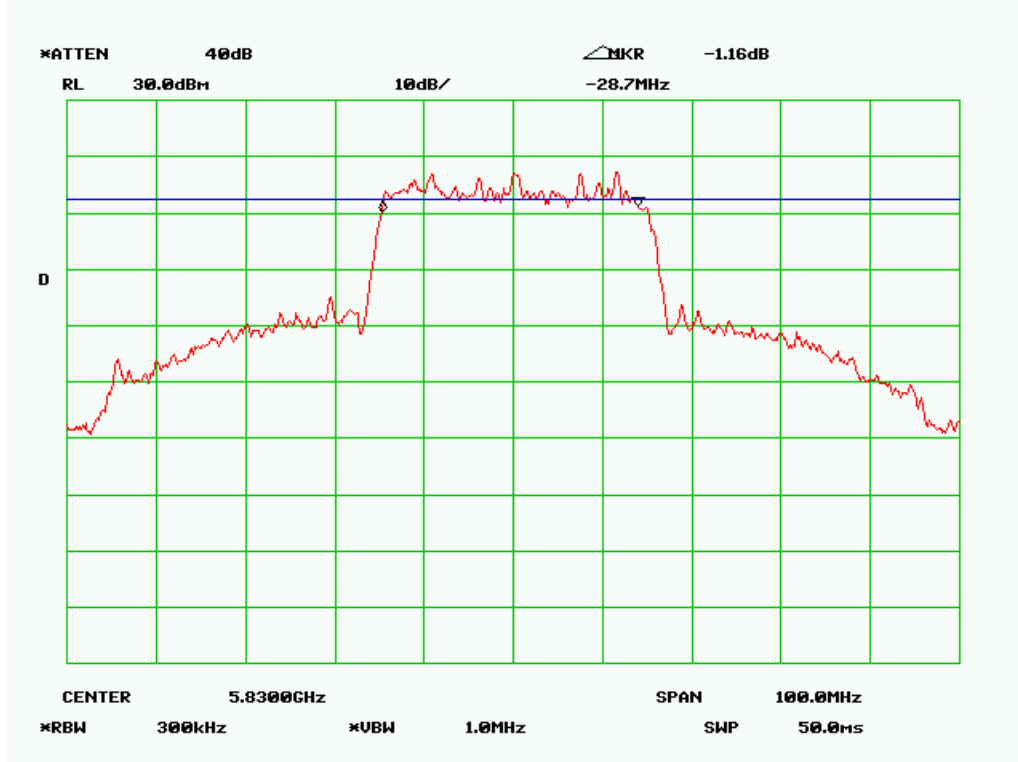

6 dB Bandwidth – High Channel (32MHz Mode 1)

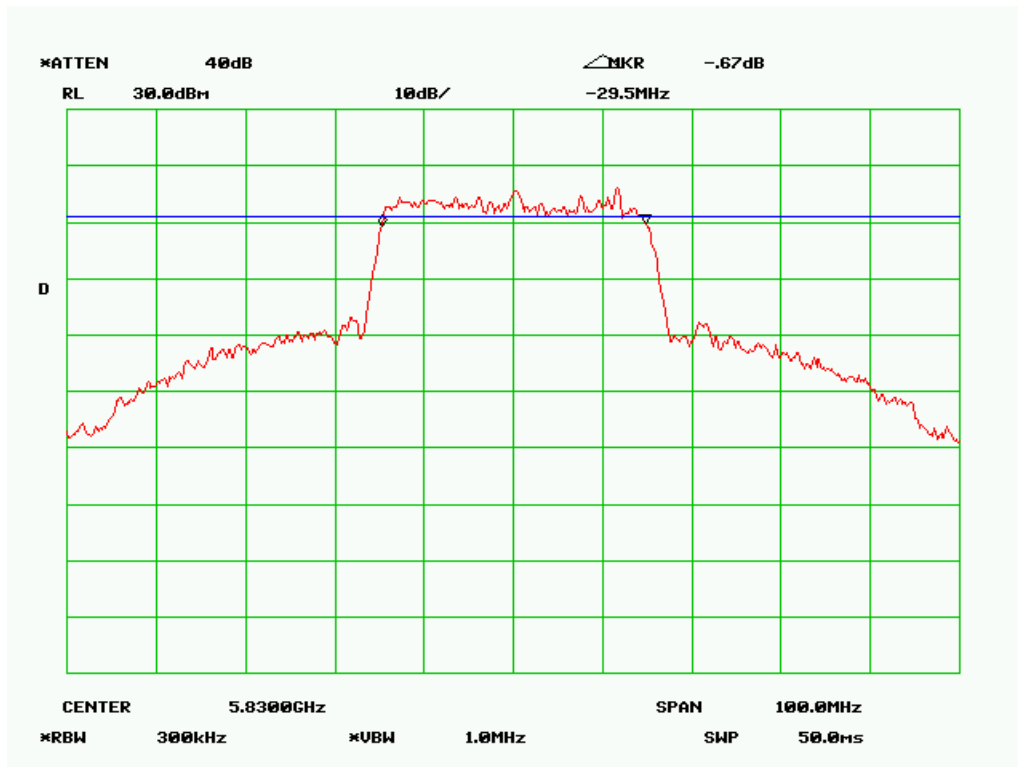

6 dB Bandwidth – High Channel (32MHz Mode 2)

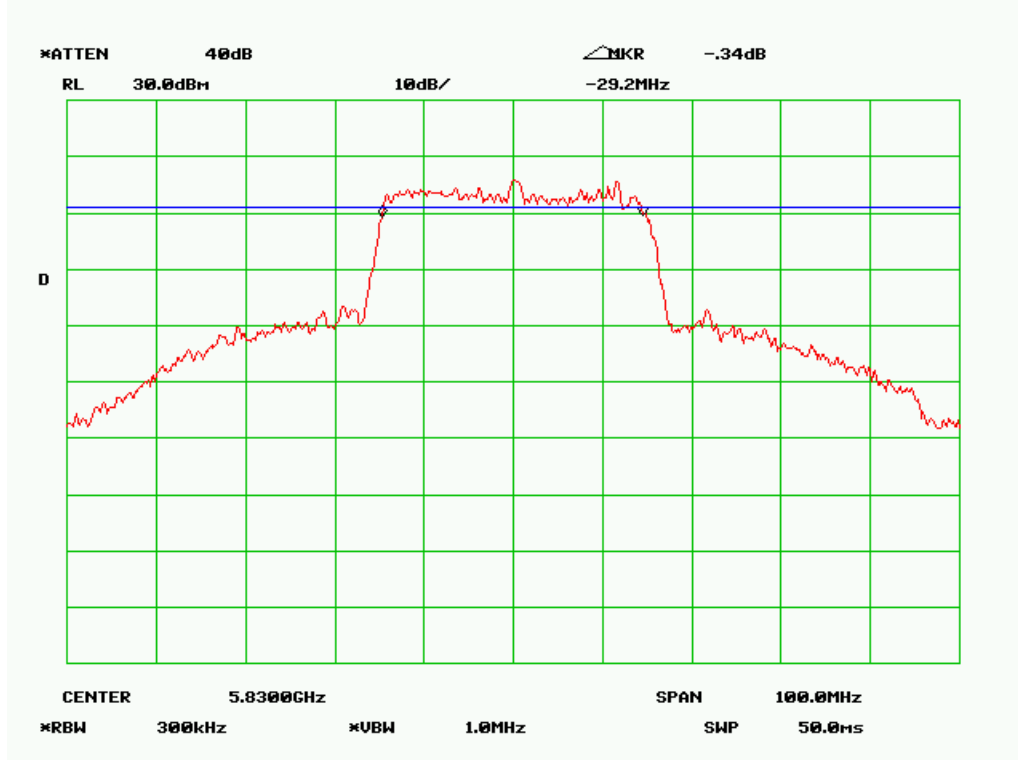

6 dB Bandwidth – High Channel (32MHz Mode 3)

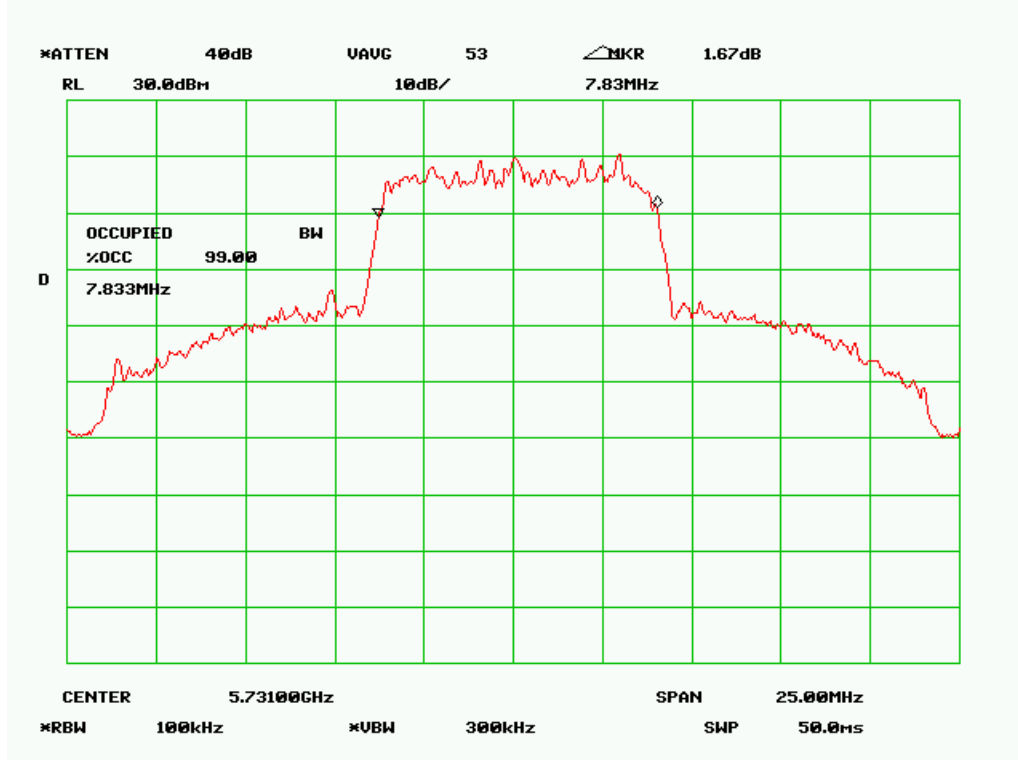

99% Bandwidth - Low Channel (8MHz Mode 1)

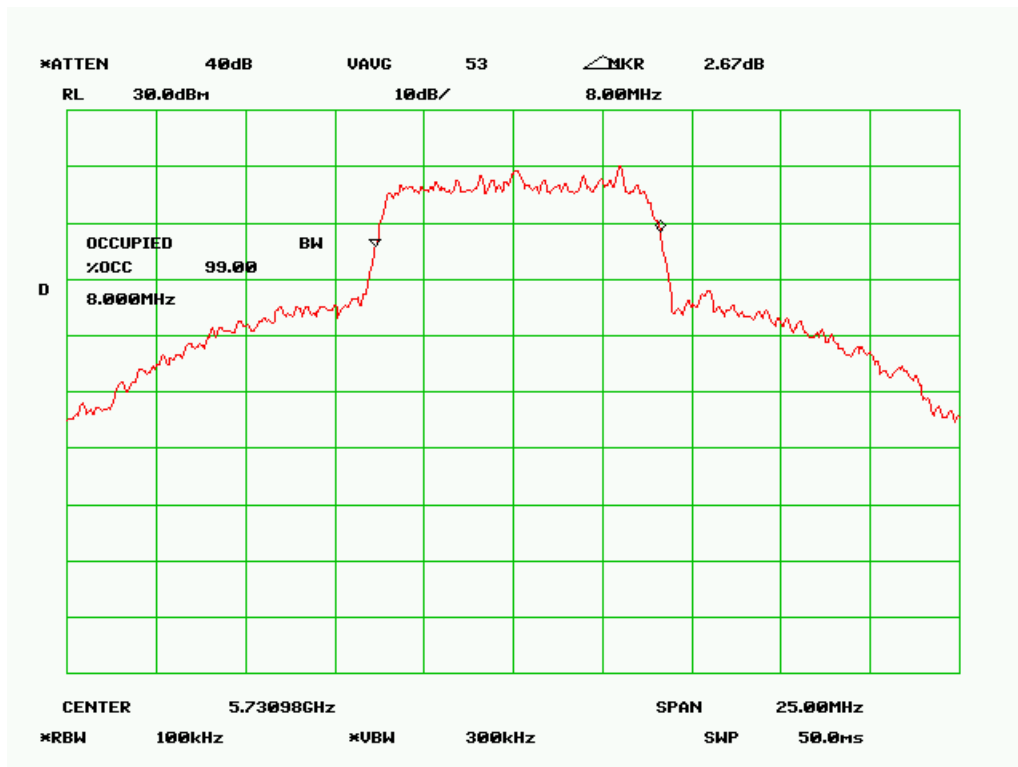

99% Bandwidth - Low Channel (8MHz Mode 2)

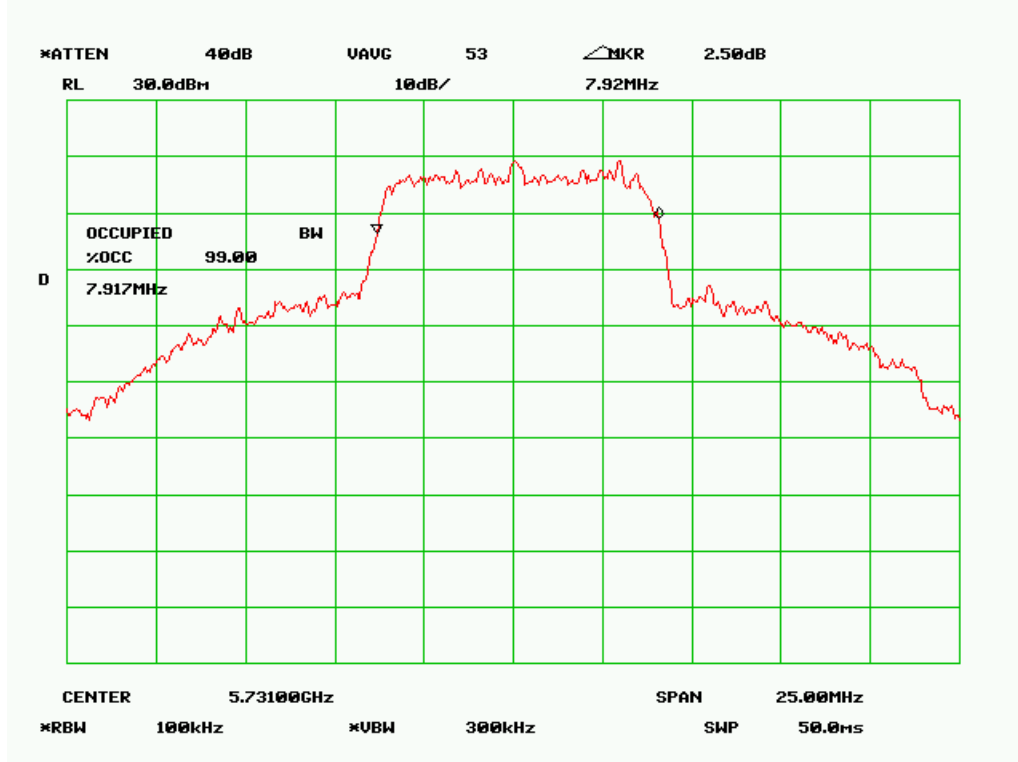

99% Bandwidth – Low Channel (8MHz Mode 3)

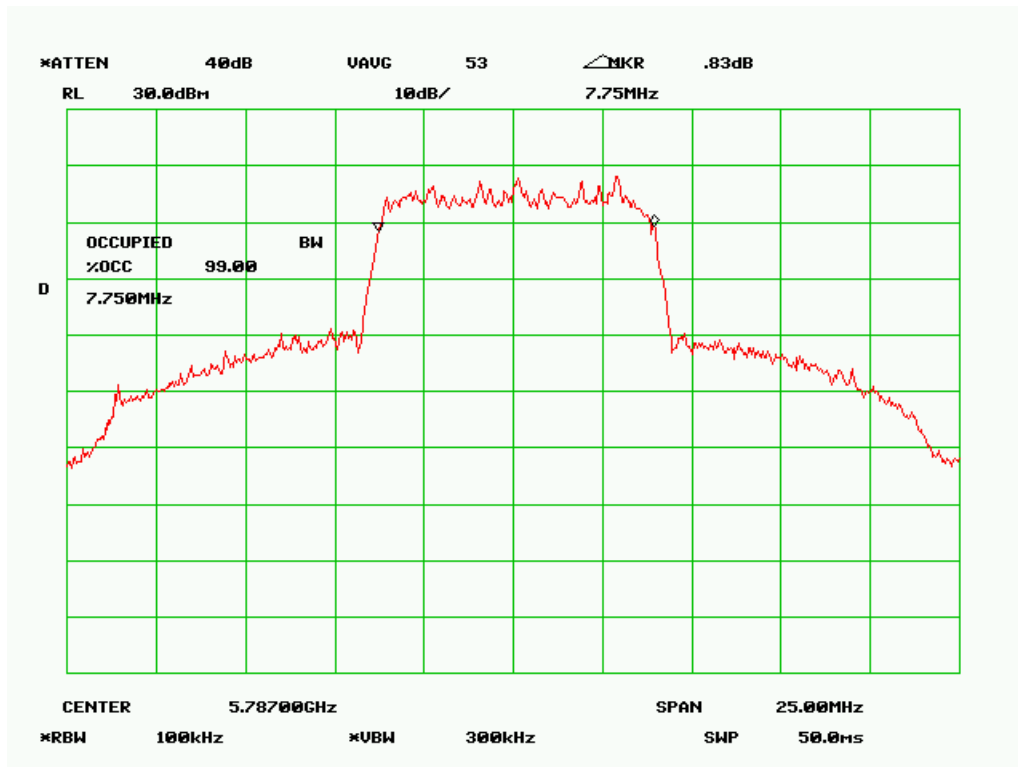

99% Bandwidth – Mid Channel (8MHz Mode 1)

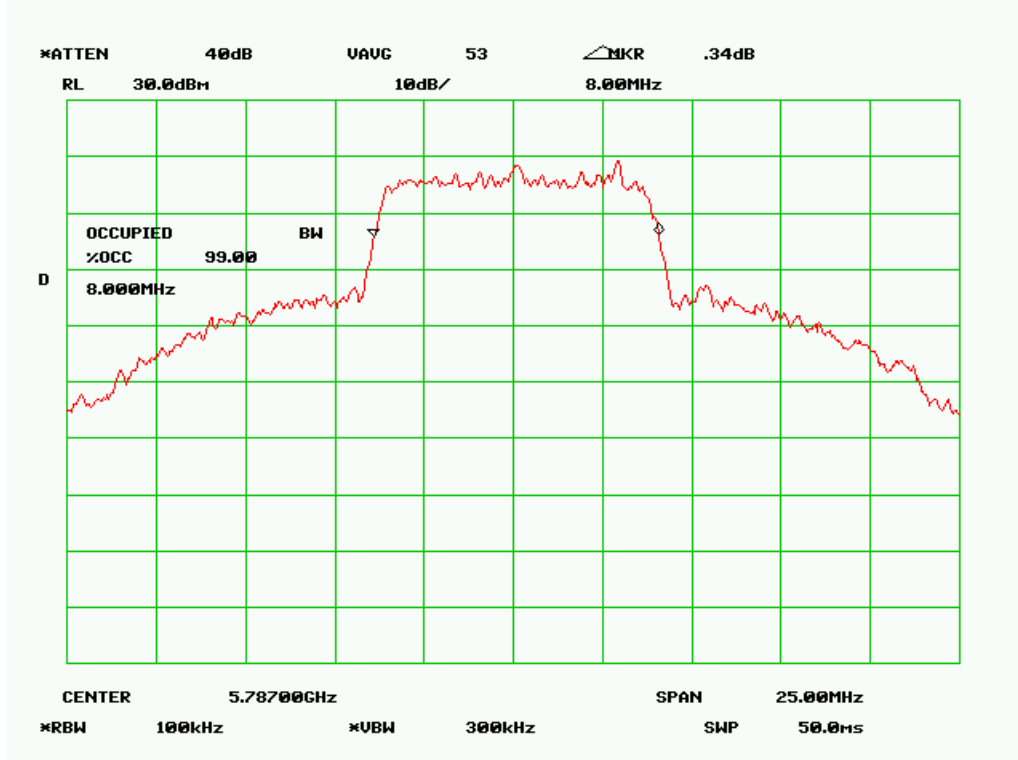

99% Bandwidth – Mid Channel (8MHz Mode 2)

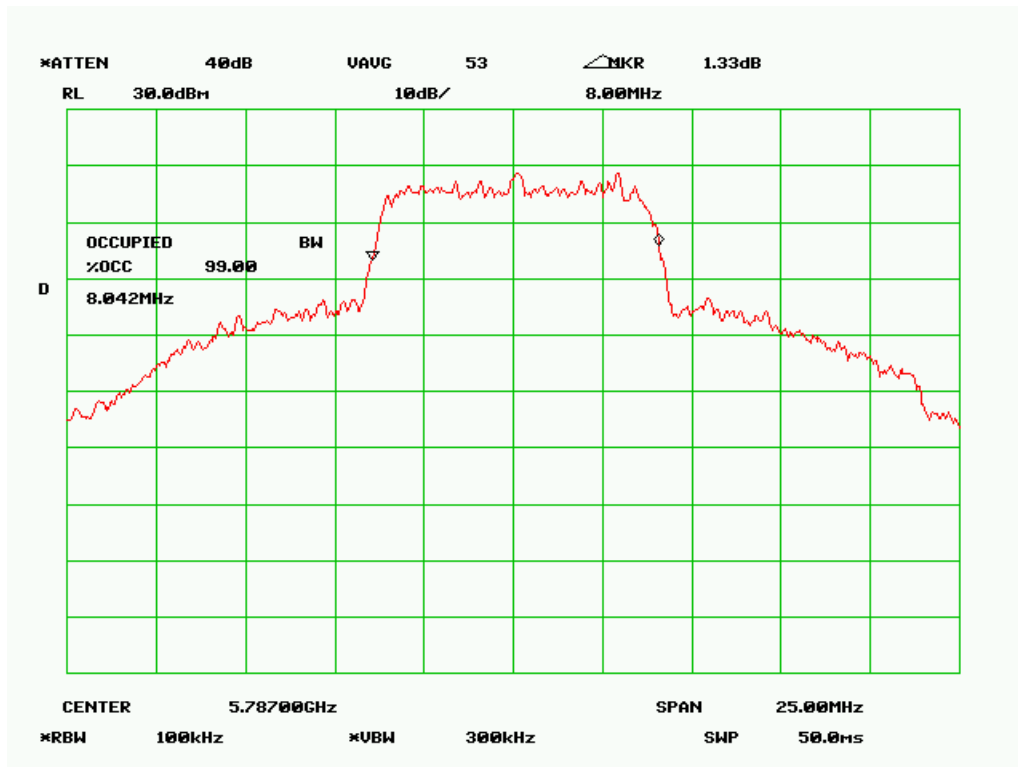

99% Bandwidth – Mid Channel (8MHz Mode 3)

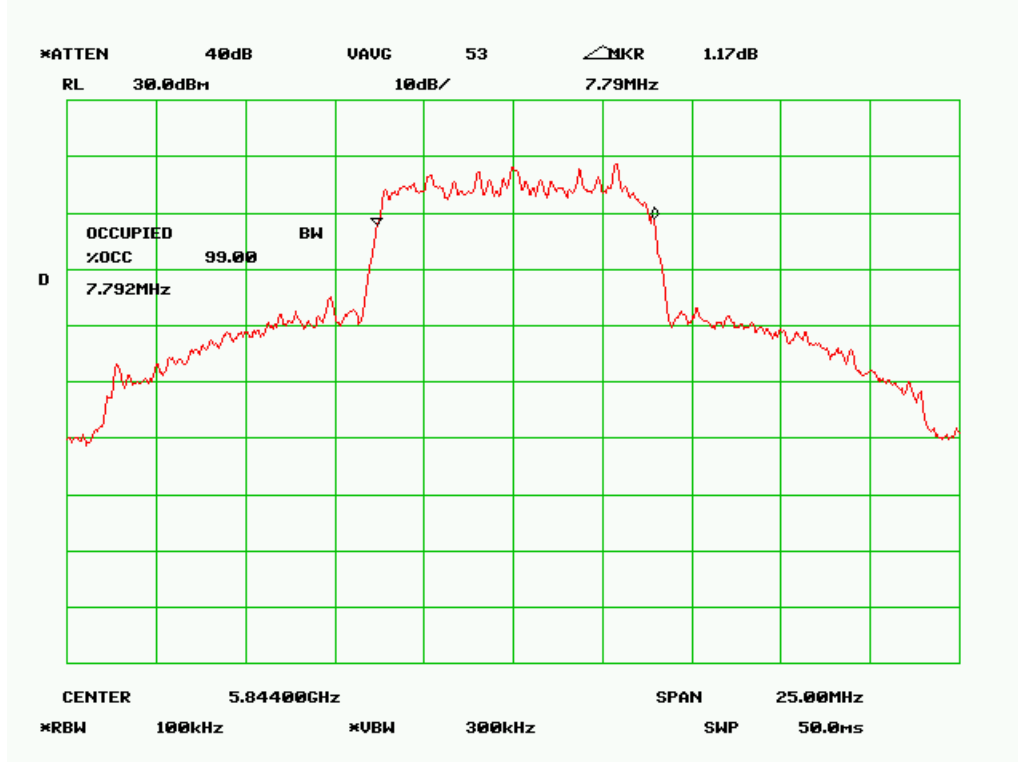

99% Bandwidth – High Channel (8MHz Mode 1)

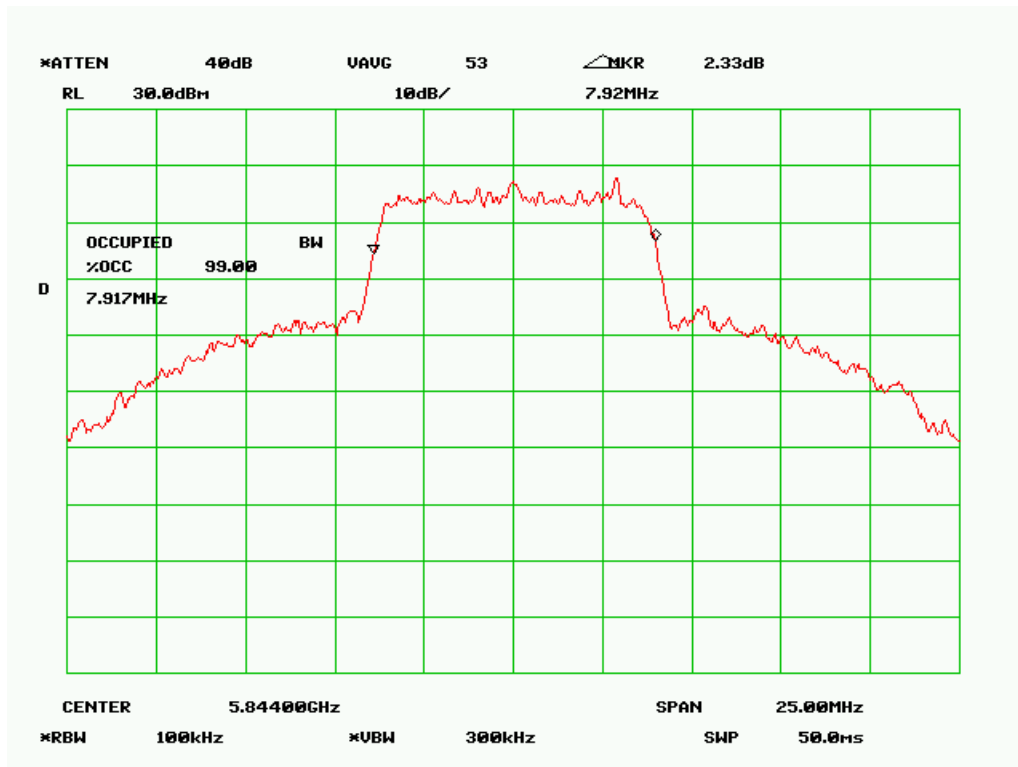

99% Bandwidth – High Channel (8MHz Mode 2)

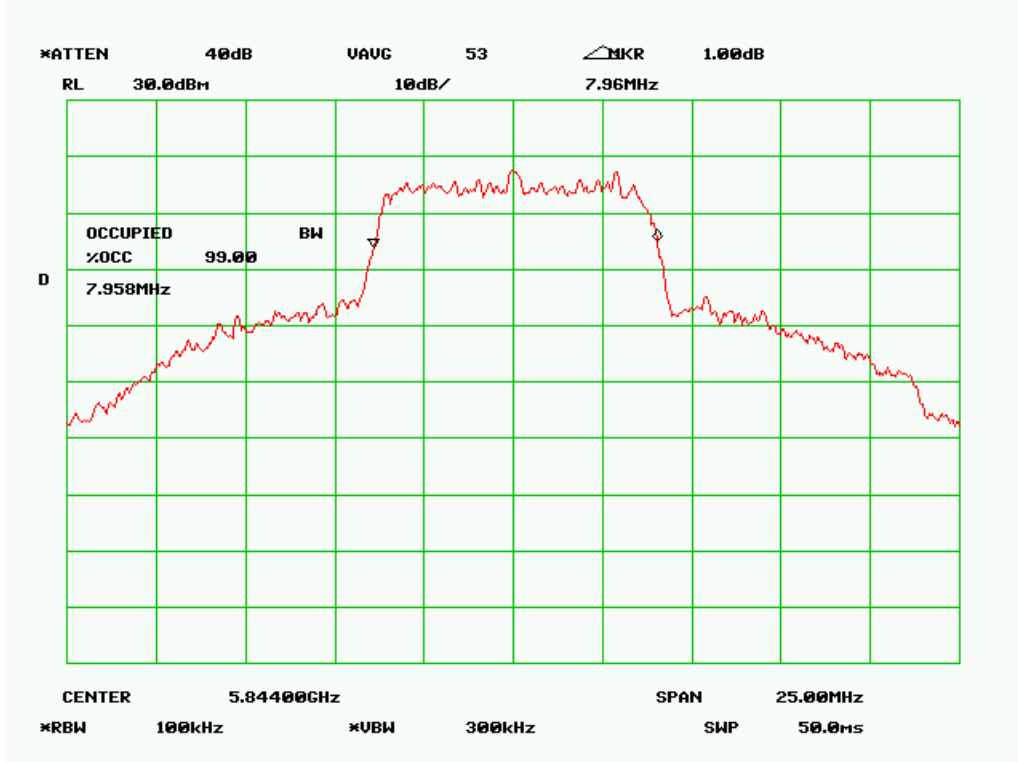

99% Bandwidth – High Channel (8MHz Mode 3)

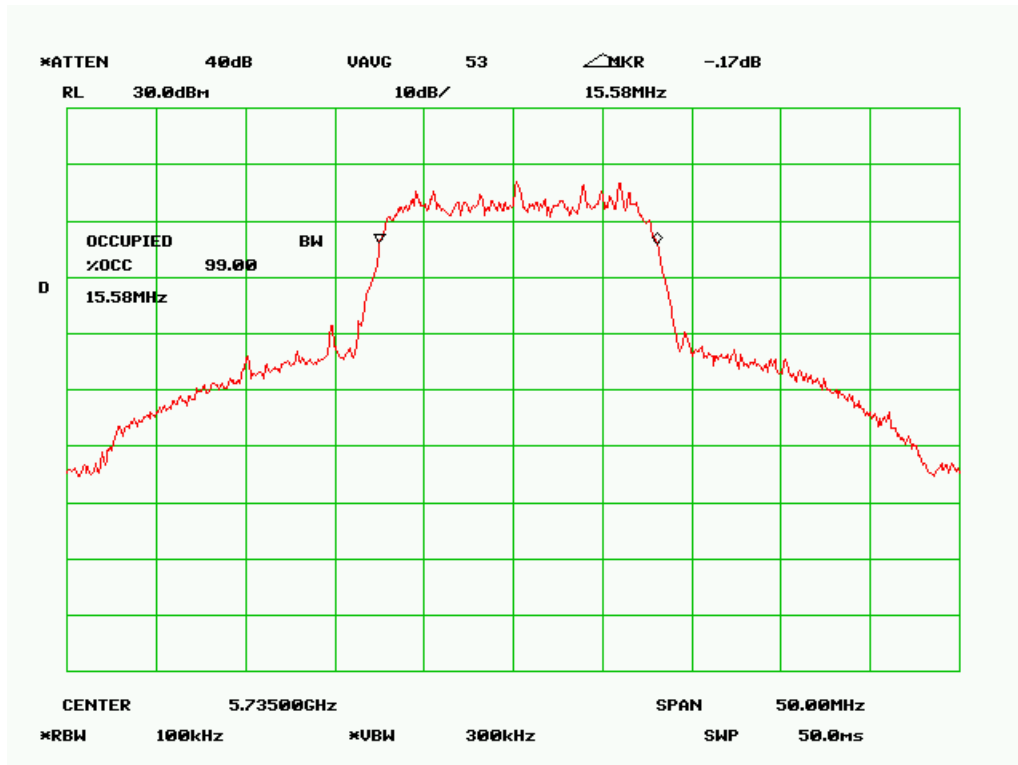

99% Bandwidth – Low Channel (16MHz Mode 1)

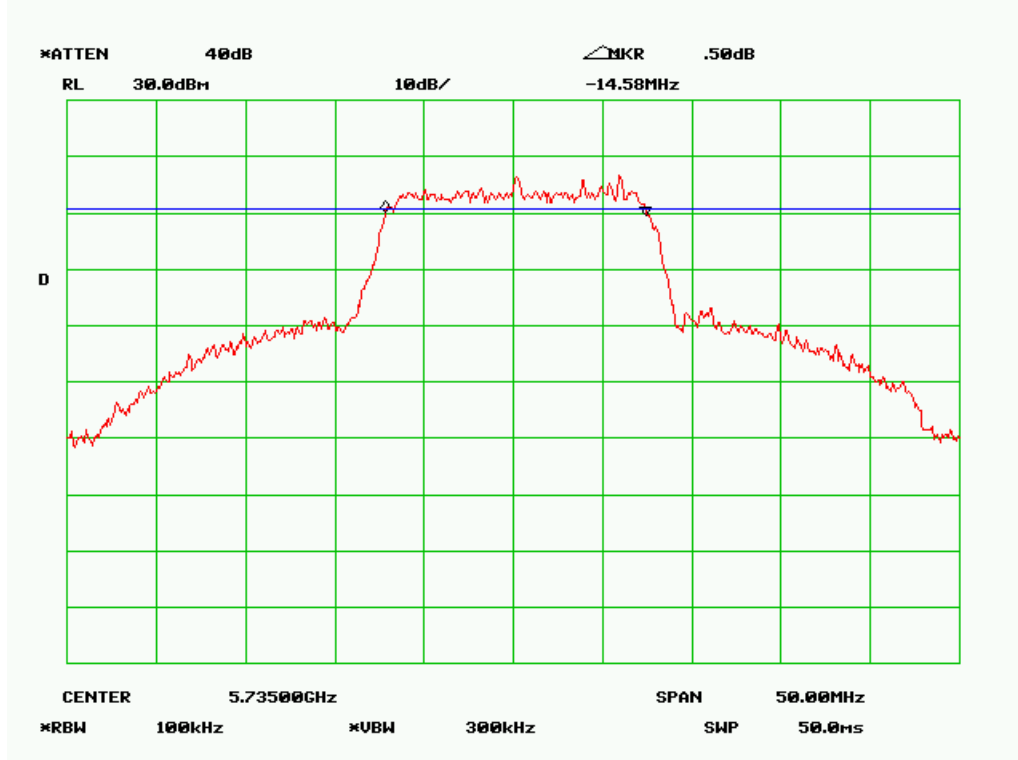

99% Bandwidth – Low Channel (16MHz Mode 2)

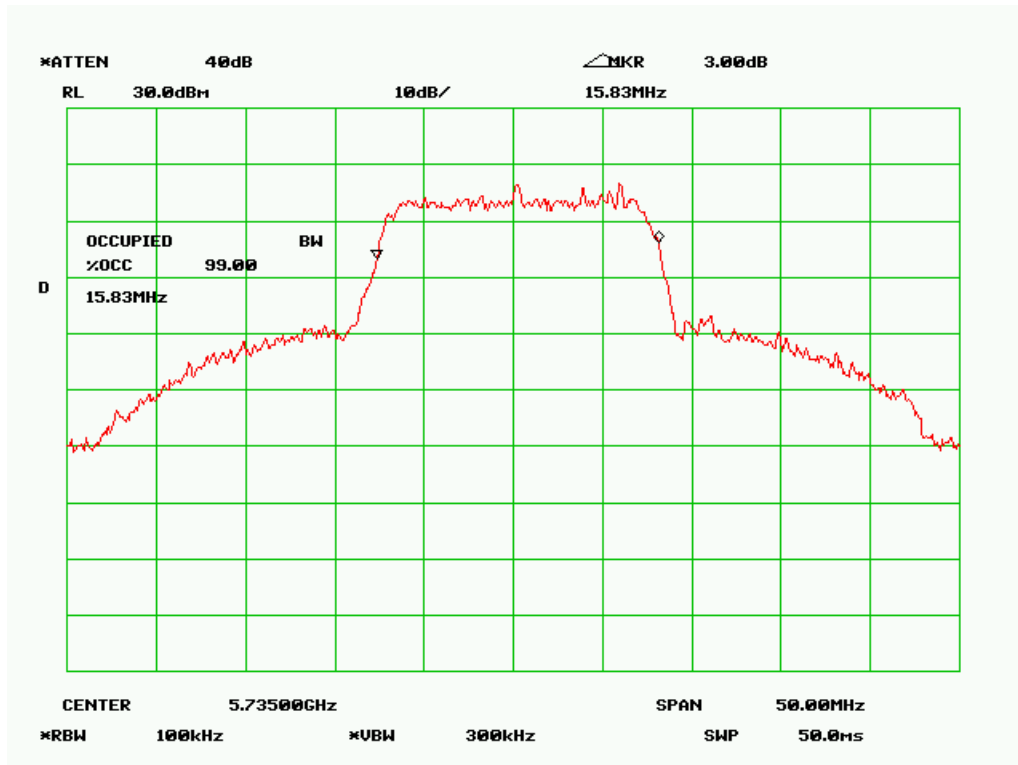

99% Bandwidth – Low Channel (16MHz Mode 3)

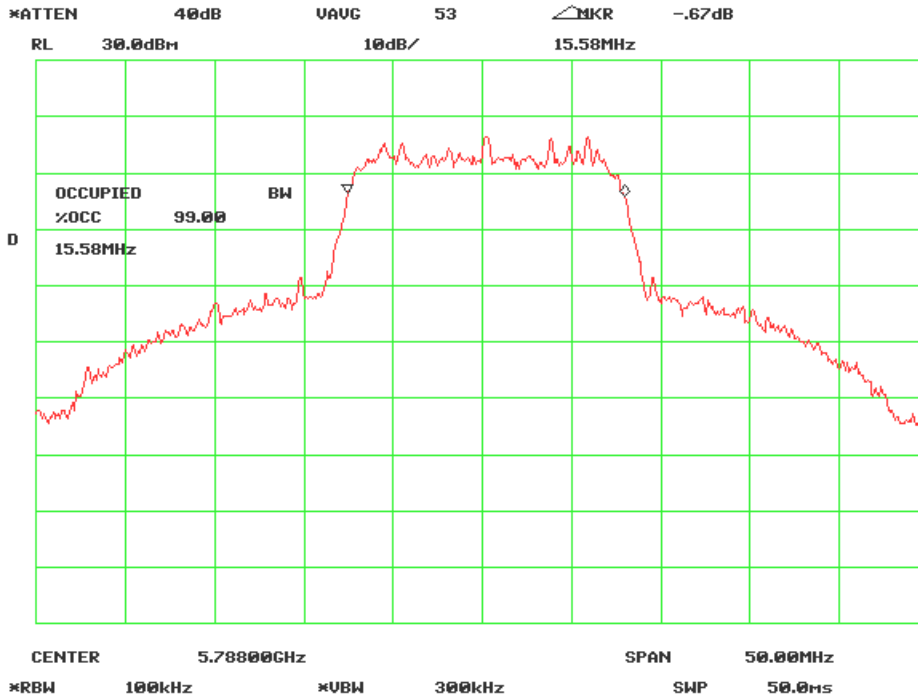

99% Bandwidth – Mid Channel (16MHz Mode 1)

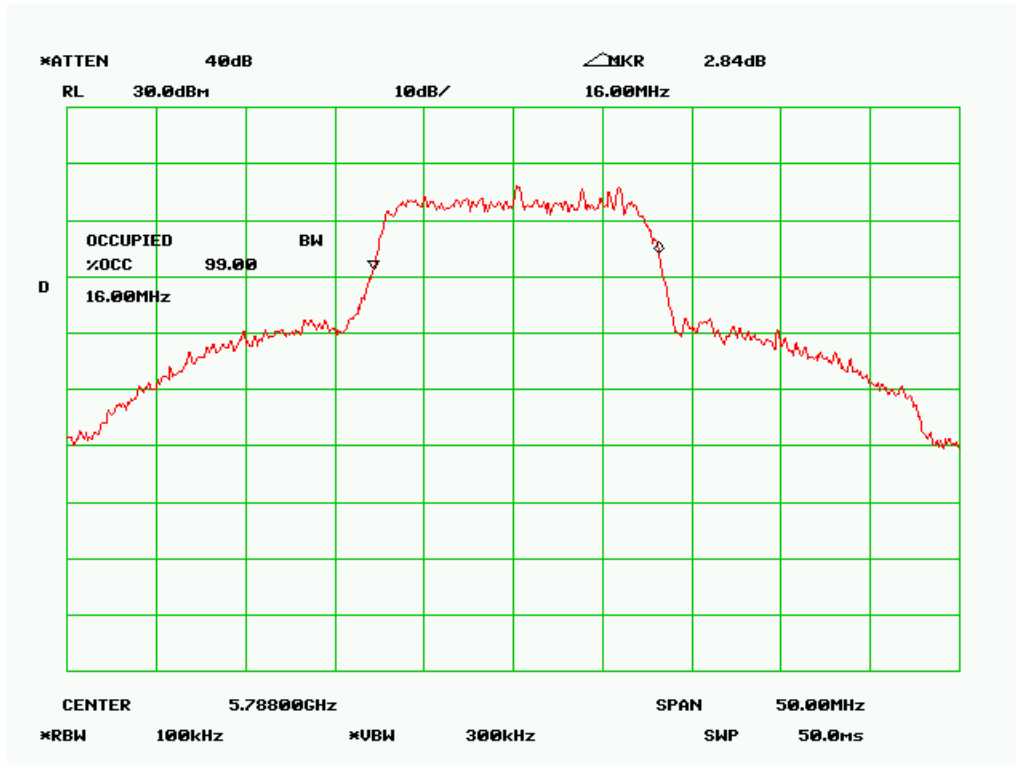

99% Bandwidth – Mid Channel (16MHz Mode 2)

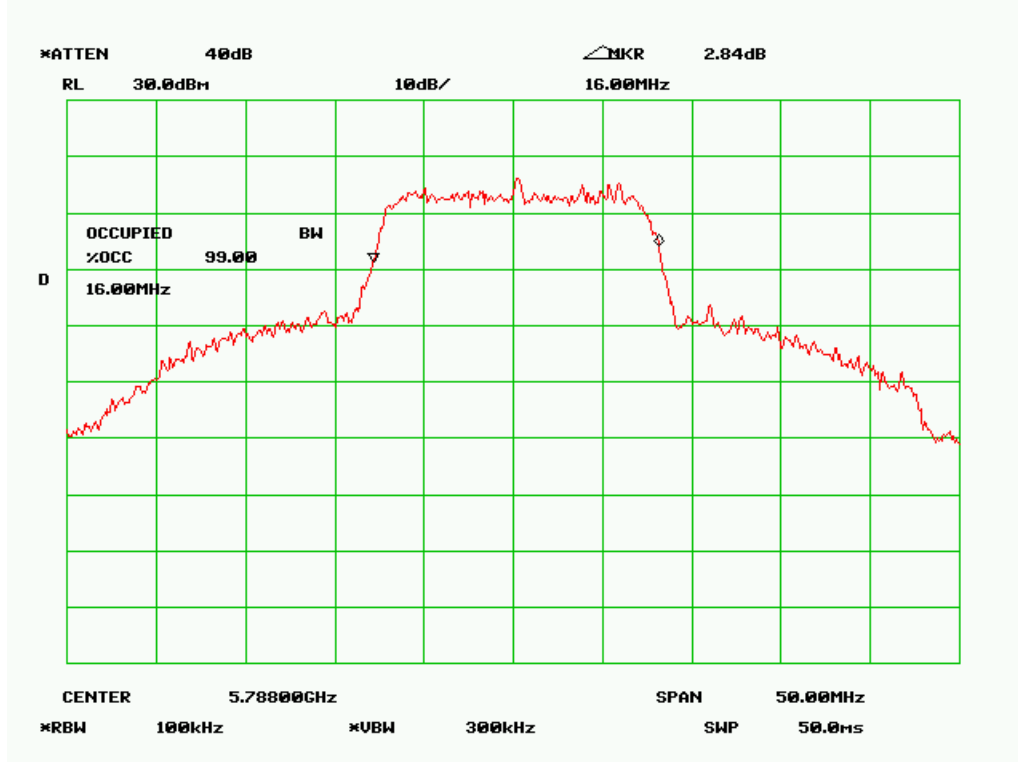

99% Bandwidth – Mid Channel (16MHz Mode 3)

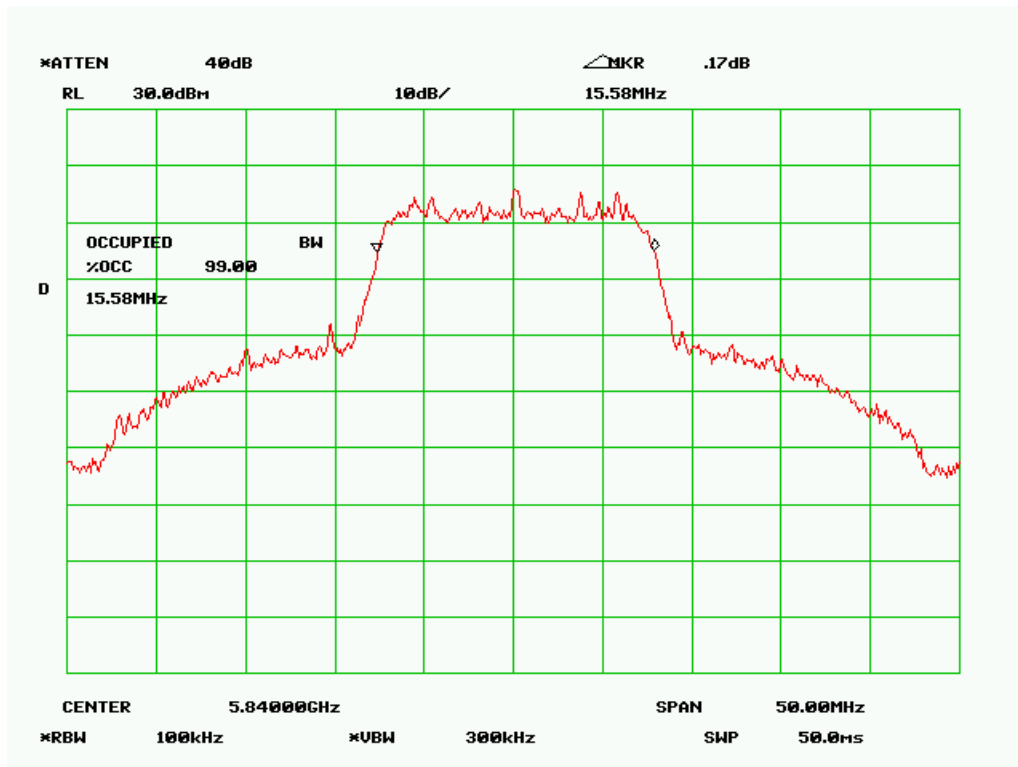

99% Bandwidth – High Channel (16MHz Mode 1)

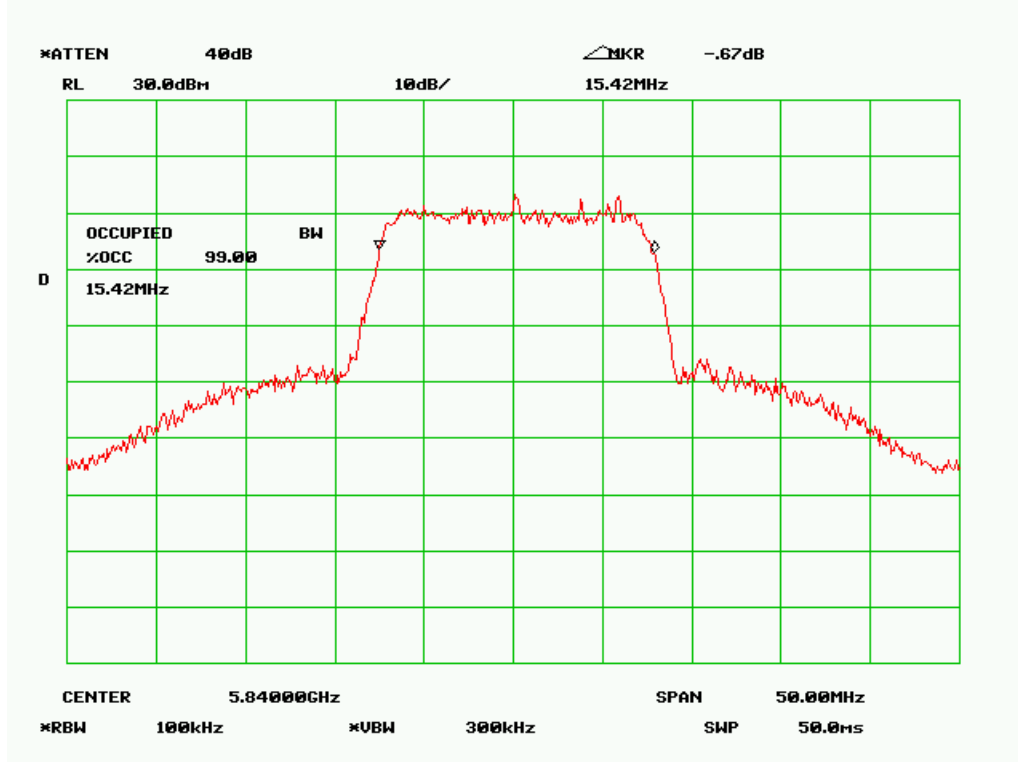

99% Bandwidth – High Channel (16MHz Mode 2)

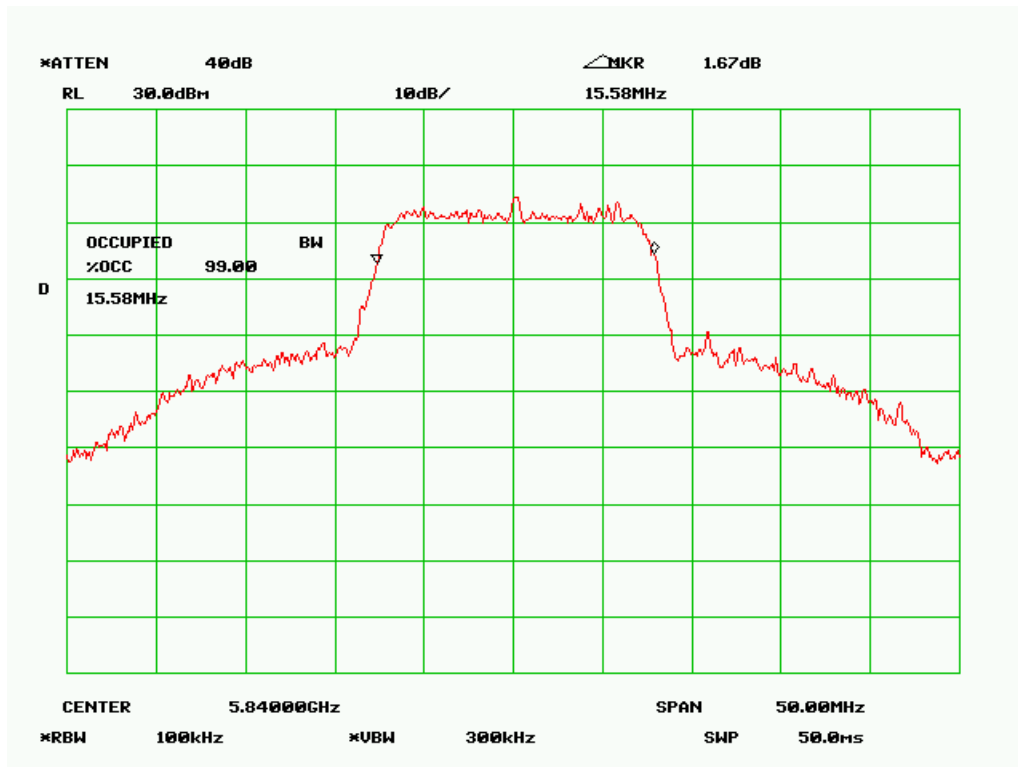

99% Bandwidth – High Channel (16MHz Mode 3)

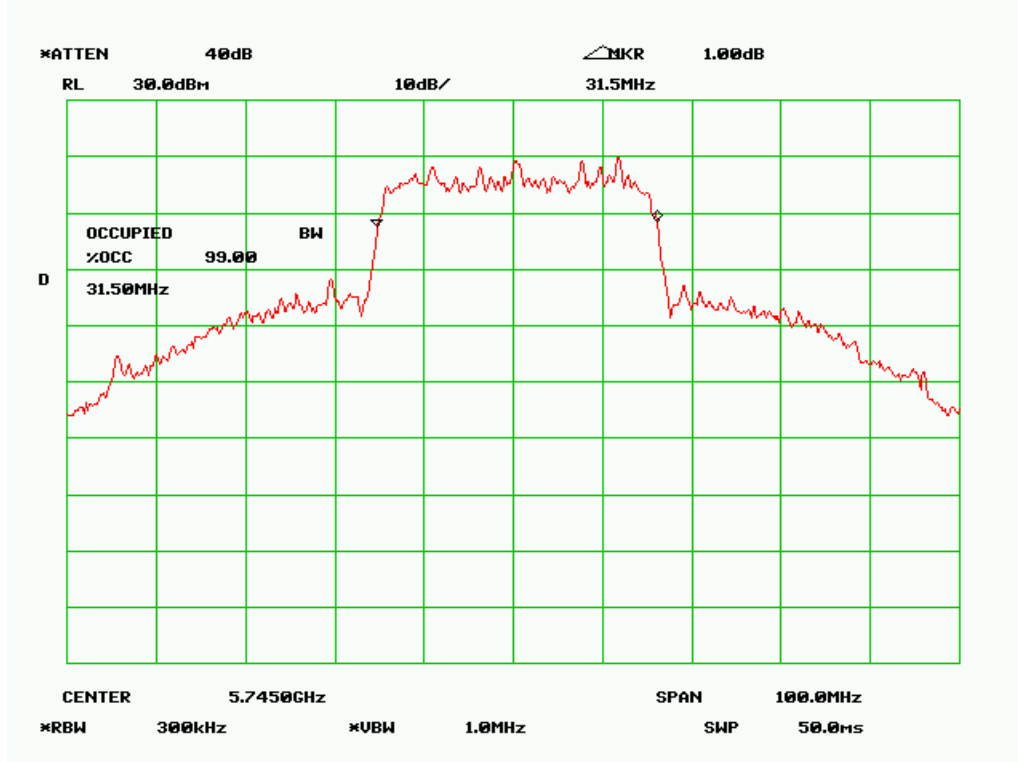

99% Bandwidth - Low Channel (32MHz Mode 1)

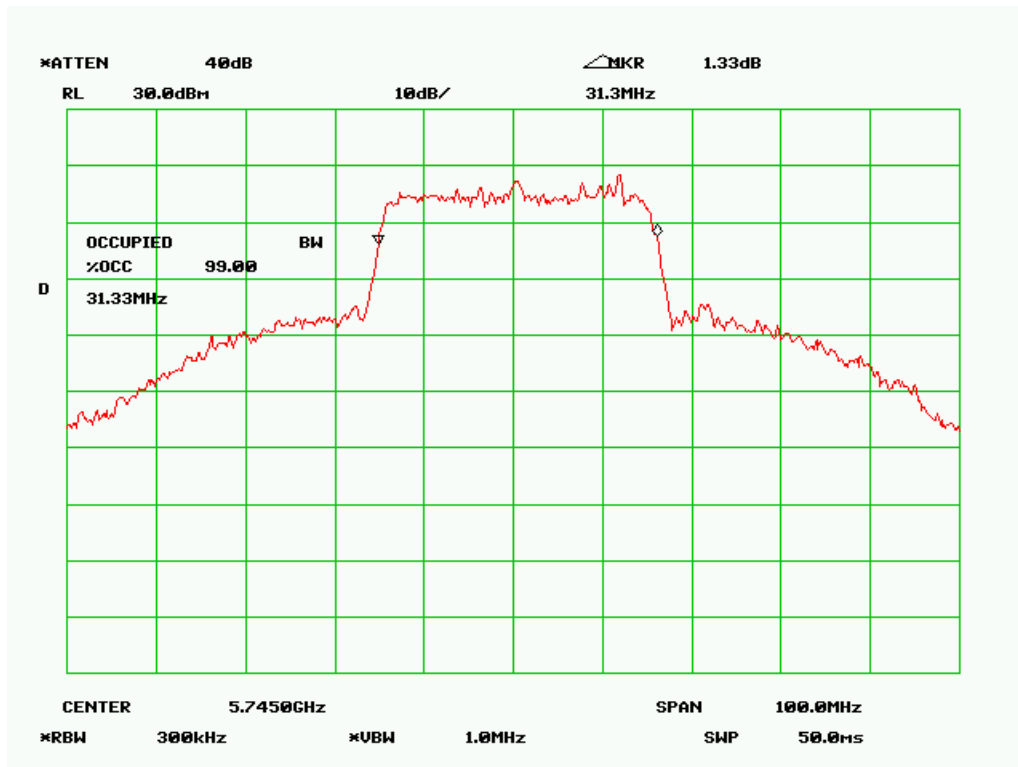

99% Bandwidth - Low Channel (32MHz Mode 2)

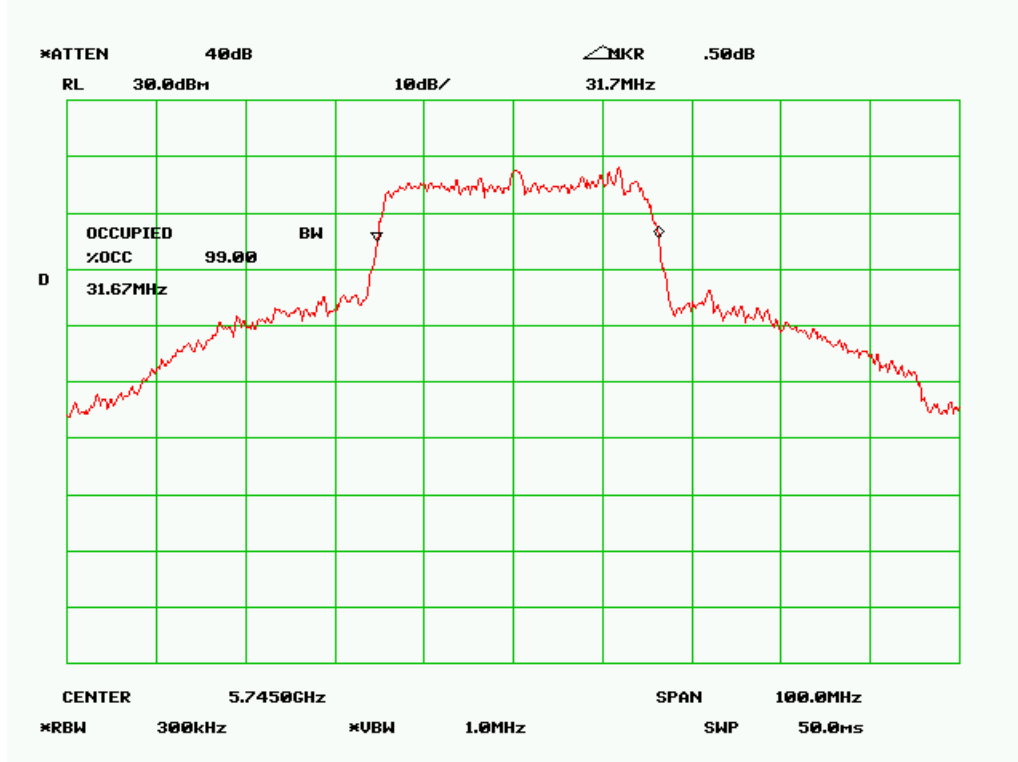

99% Bandwidth – Low Channel (32MHz Mode 3)

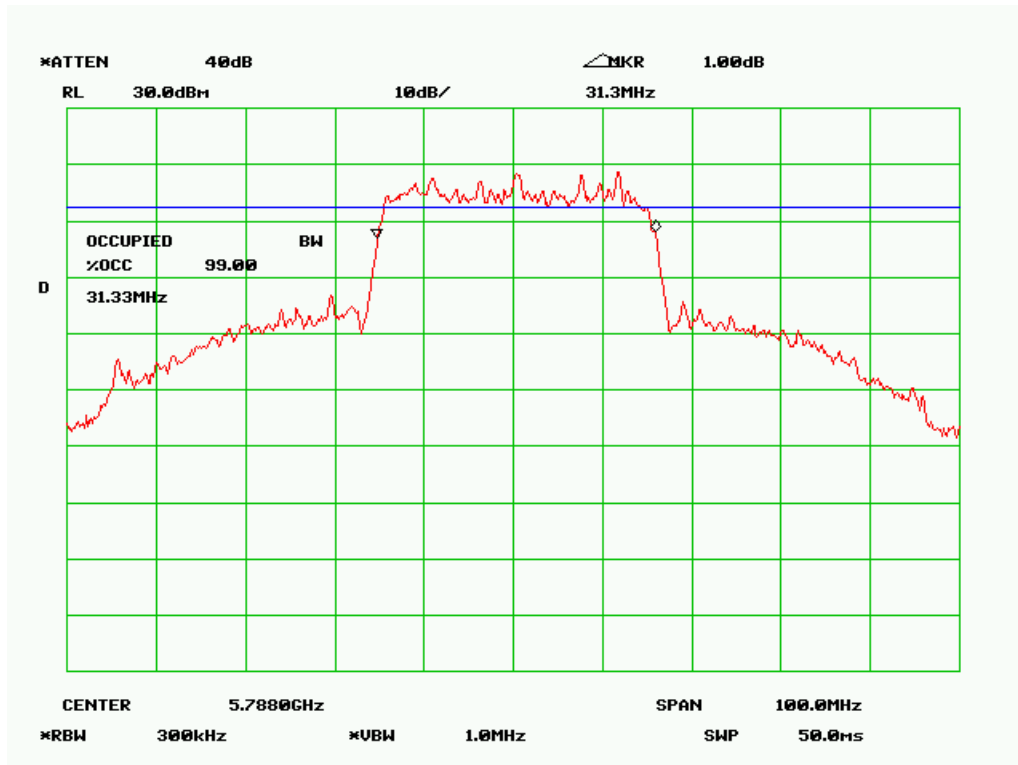

99% Bandwidth – Mid Channel (32MHz Mode 1)

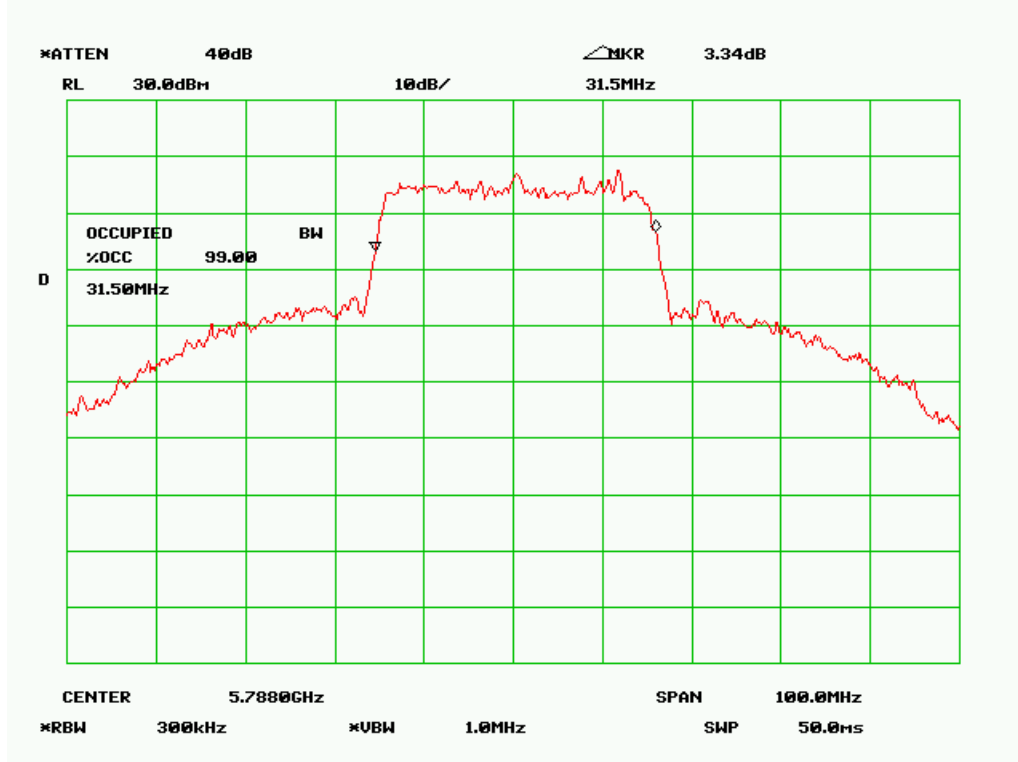

99% Bandwidth – Mid Channel (32MHz Mode 2)

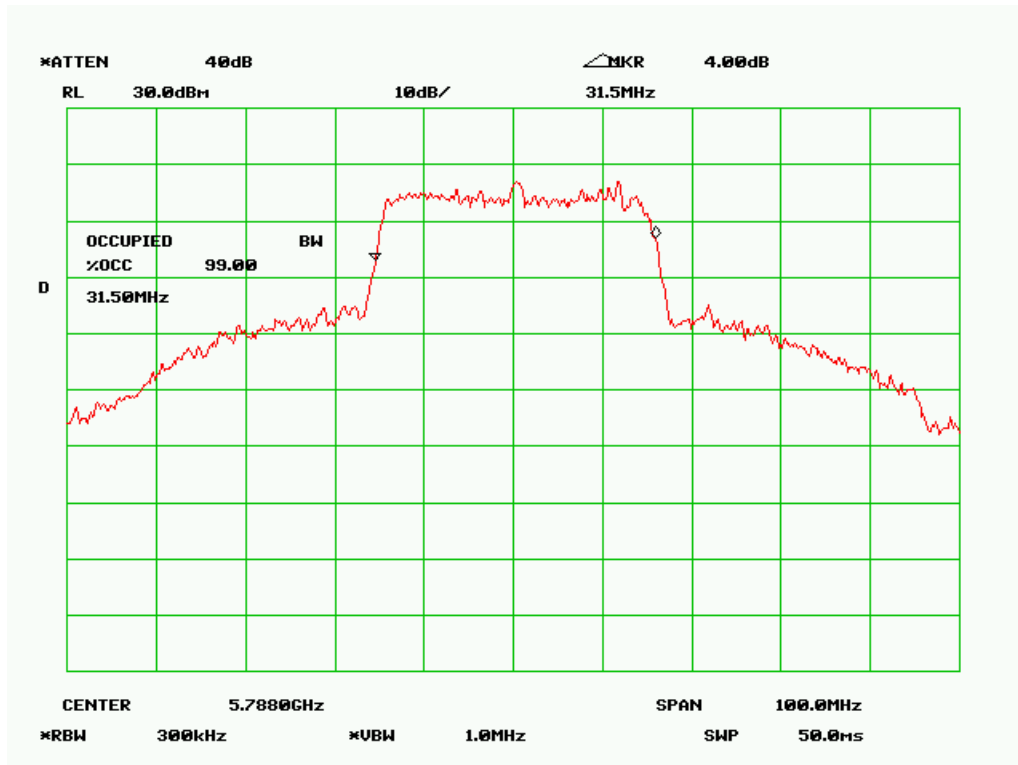

99% Bandwidth – Mid Channel (32MHz Mode 3)

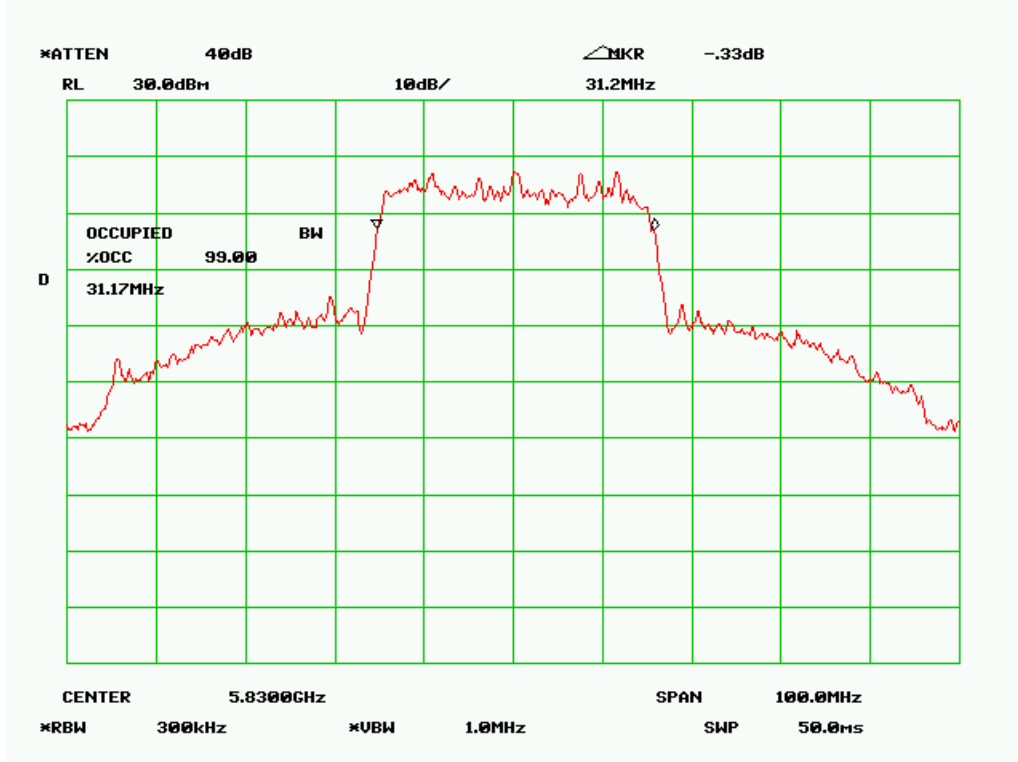

99% Bandwidth – High Channel (32MHz Mode 1)

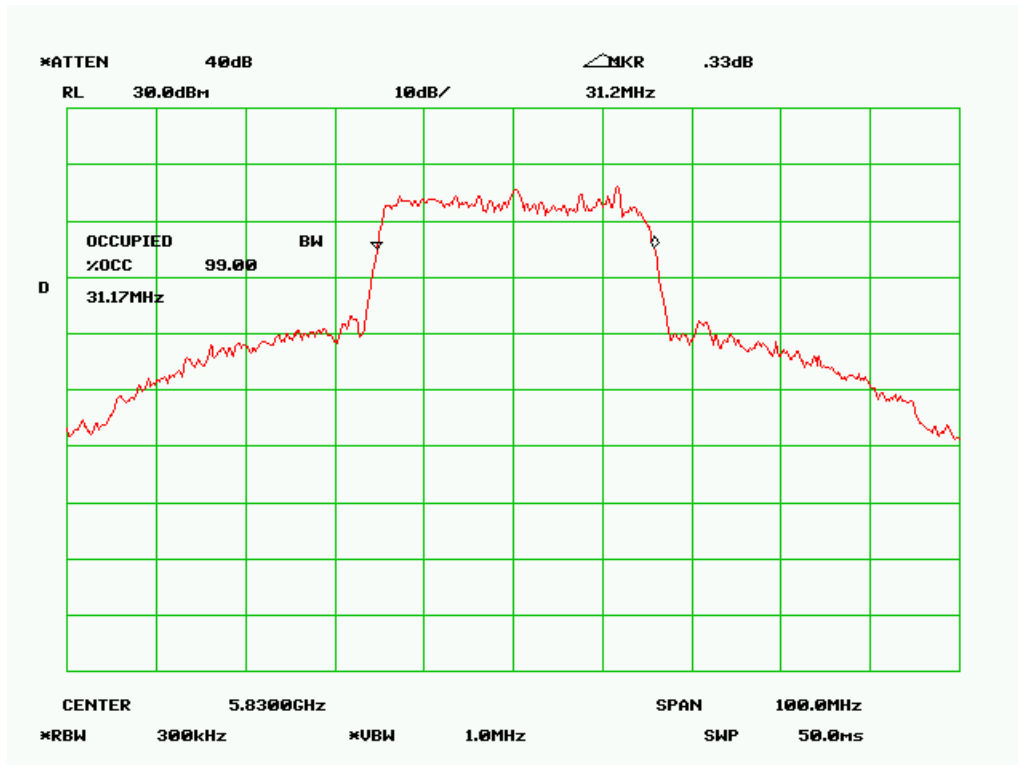

99% Bandwidth – High Channel (32MHz Mode 2)

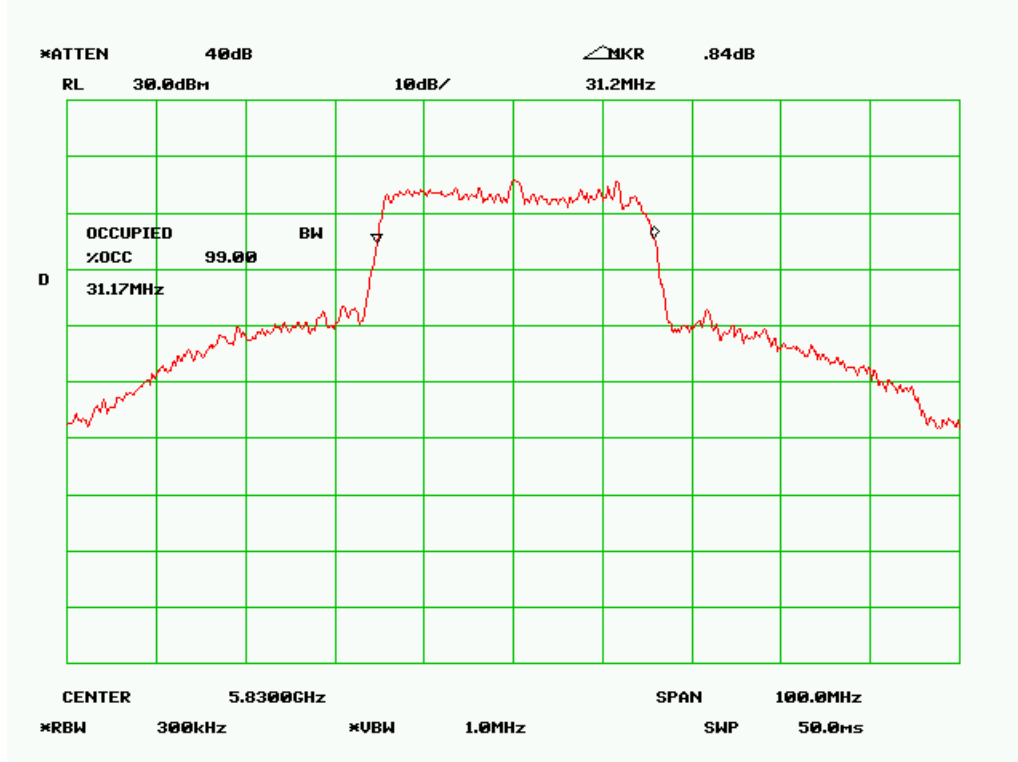

99% Bandwidth – High Channel (32MHz Mode 3)

5.4 Peak Spectral Density

1. Conducted Measurement
EUT was set for low , mid, high channel with modulated mode and highest RF output power.
The spectrum analyzer was connected to the antenna terminal.
2. Conducted Emissions Measurement Uncertainty
All test measurements carried out are traceable to national standards. The uncertainty of the measurement at a confidence level of approximately 95% (in the case where distributions are normal), with a coverage factor of 2, in the range 30MHz – 40GHz is $\pm 1.5\text{dB}$.
3. Environmental Conditions

Temperature	23°C
Relative Humidity	50%
Atmospheric Pressure	1019mbar
4. Test Date : July 10-21 2009
Tested By :Choon Sian Ooi

Standard Requirement : 47 CFR §15.247(e); RSS210(A8.3)

For digitally modulated systems, the power spectral density conducted from the intentional radiator to the antenna shall not be greater than 8 dBm in any 3 kHz band during any time interval of continuous transmission

Procedures: The Peak Spectral density measurement was taken conducted using a spectrum analyzer.

RBW=3KHz, VBW > RBW , Sweep time to SPAN/RBW (sec)

Test Result :

Refer to the attached plots.

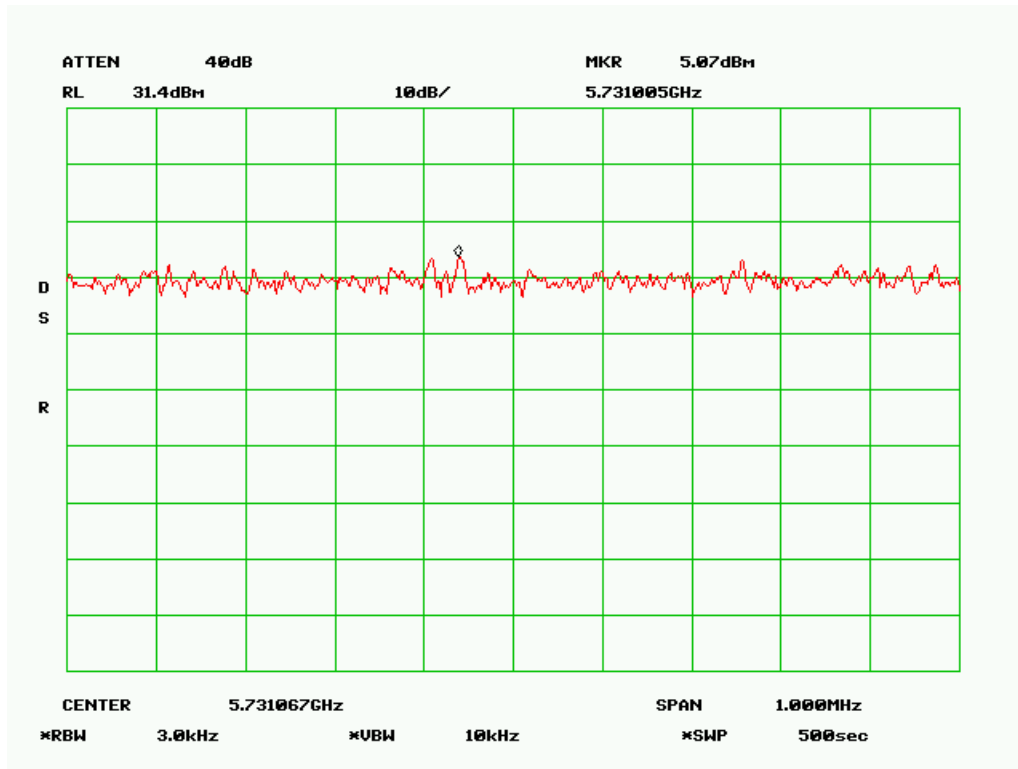

Low Channel (8MHz Mode 1)

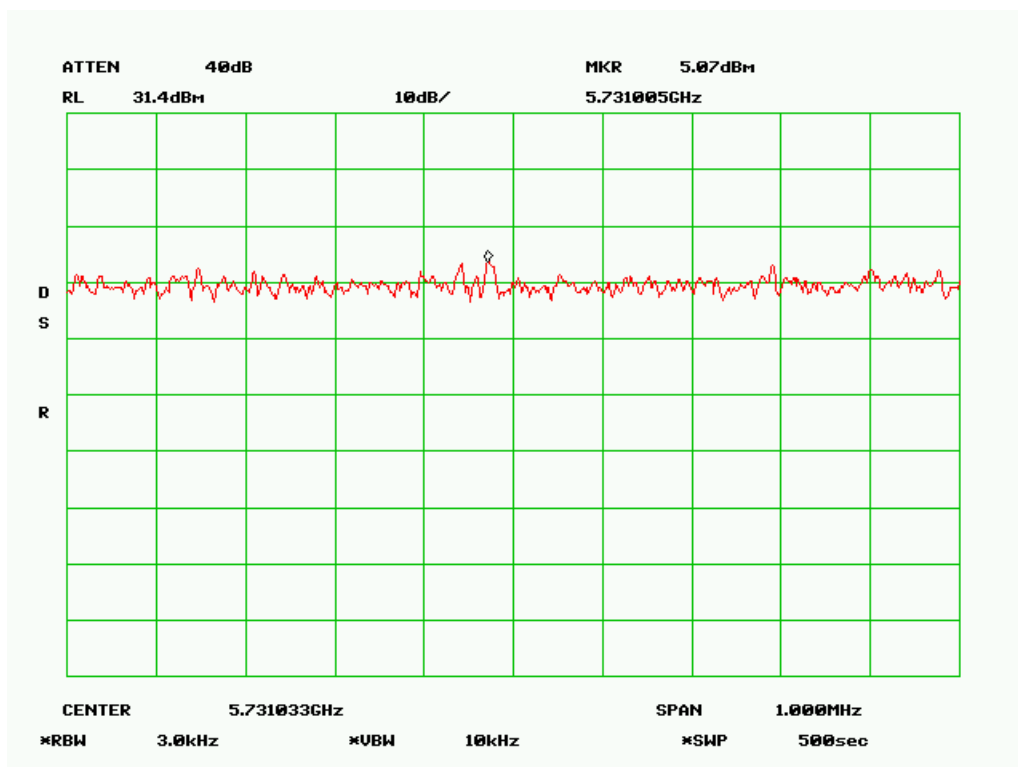

Low Channel (8MHz Mode 2)

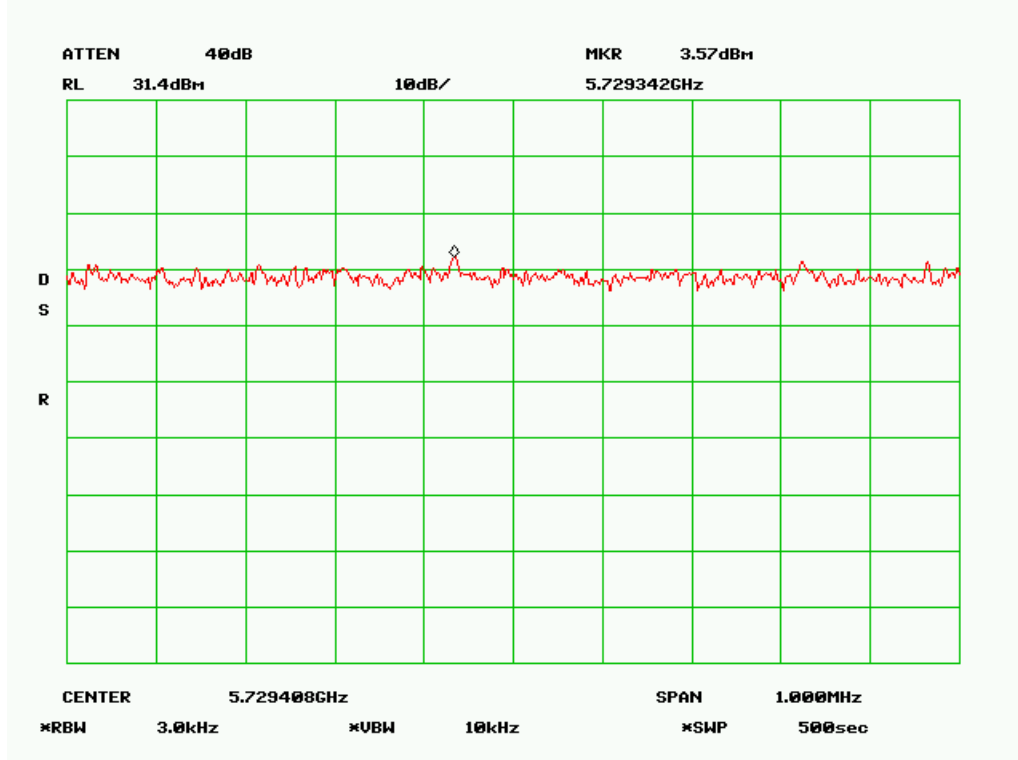

Low Channel (8MHz Mode 3)

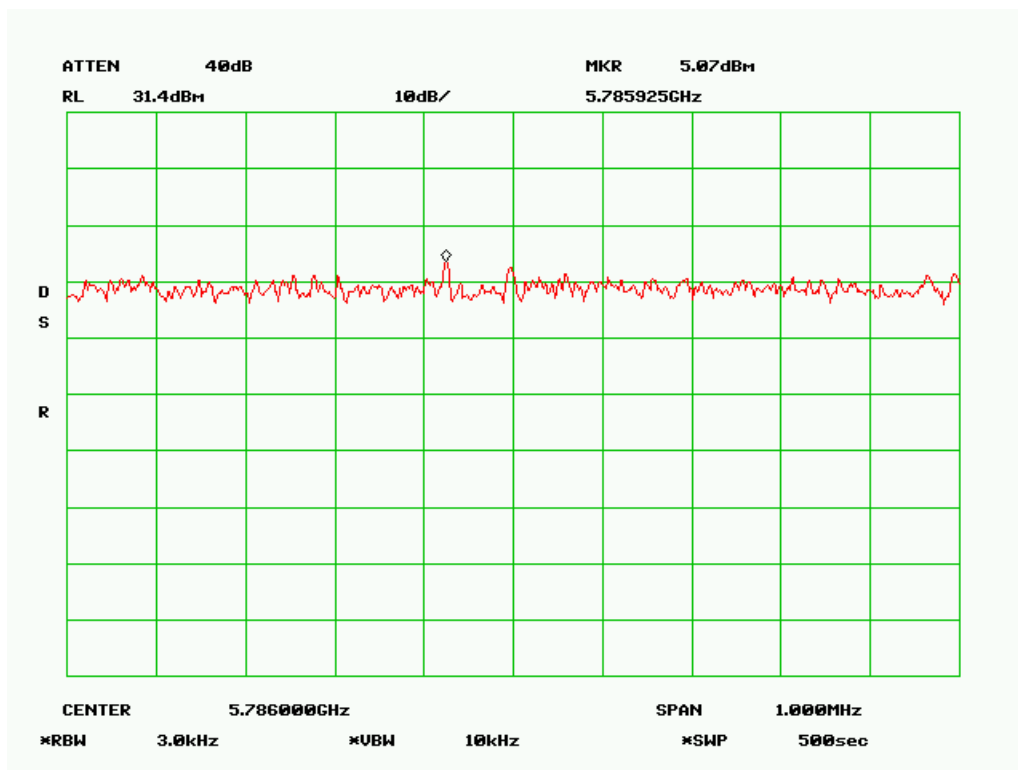

Mid Channel (8MHz Mode 1)

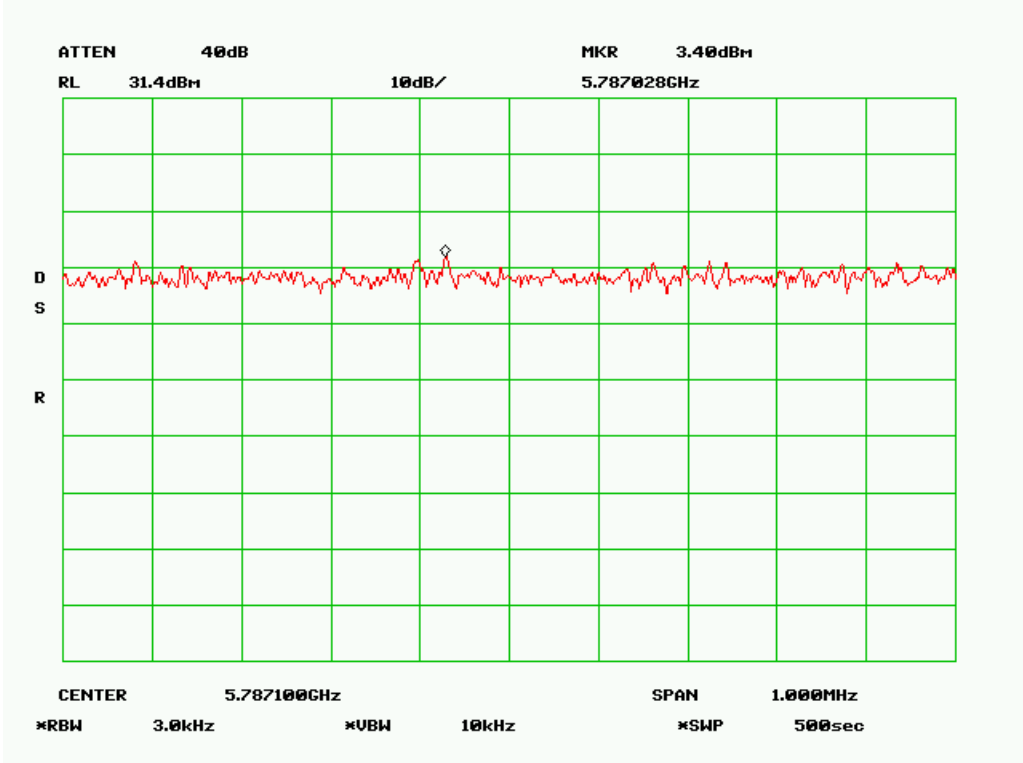

Mid Channel (8MHz Mode 2)

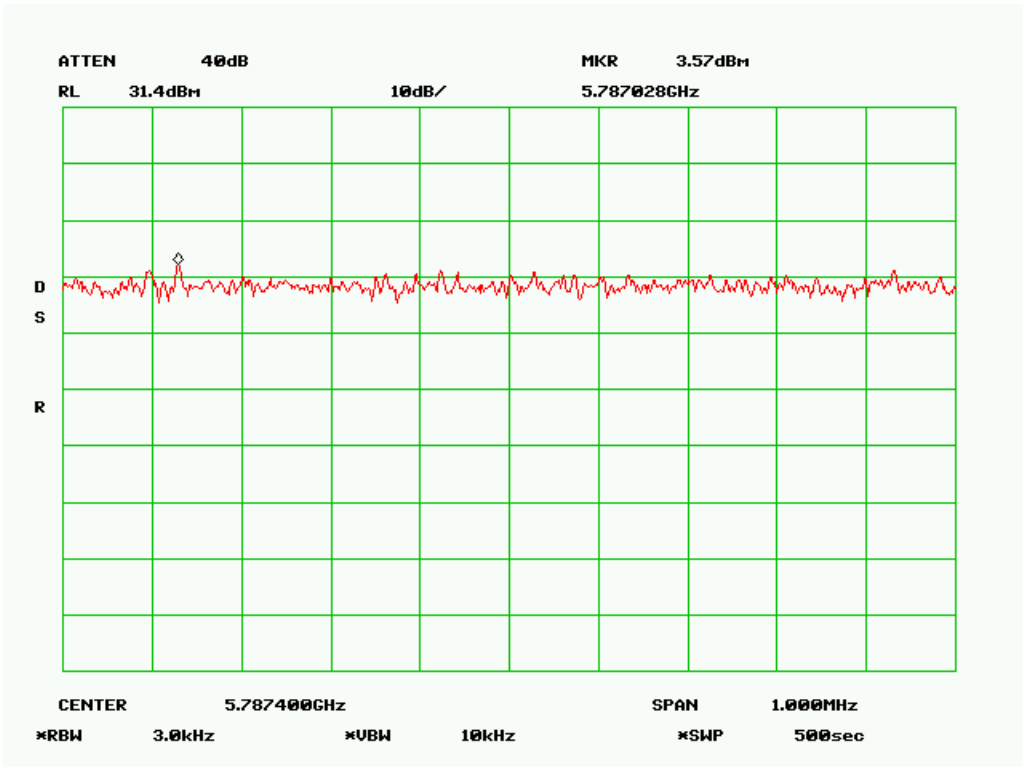

Mid Channel (8MHz Mode 3)

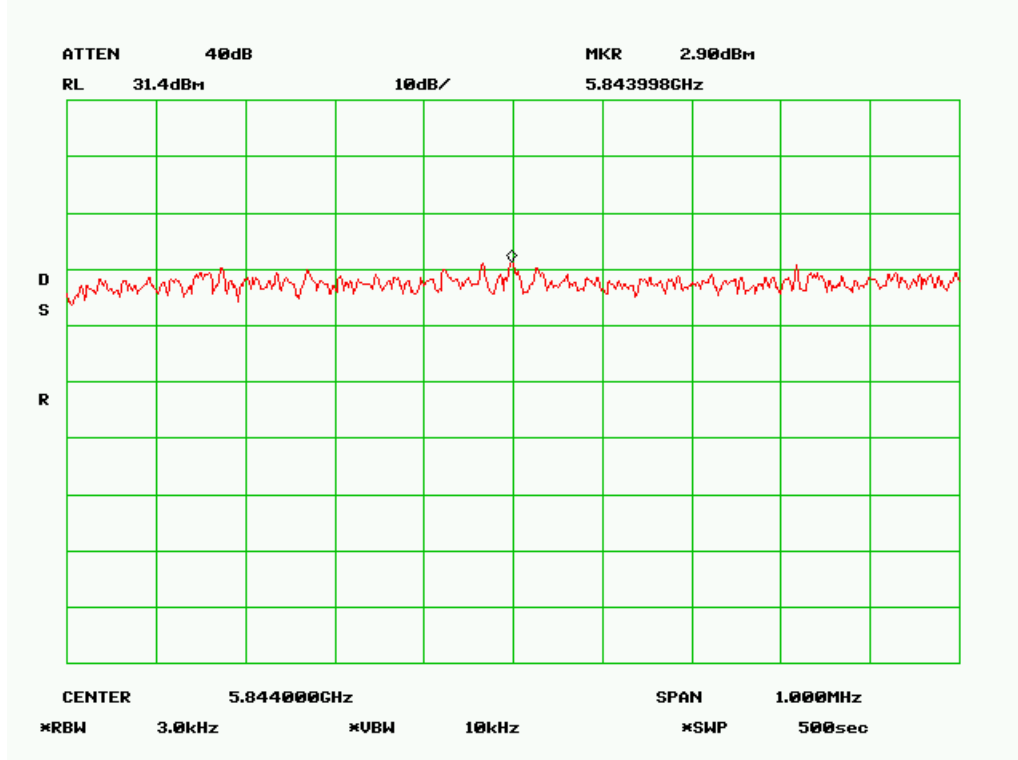

High Channel (8MHz Mode 1)

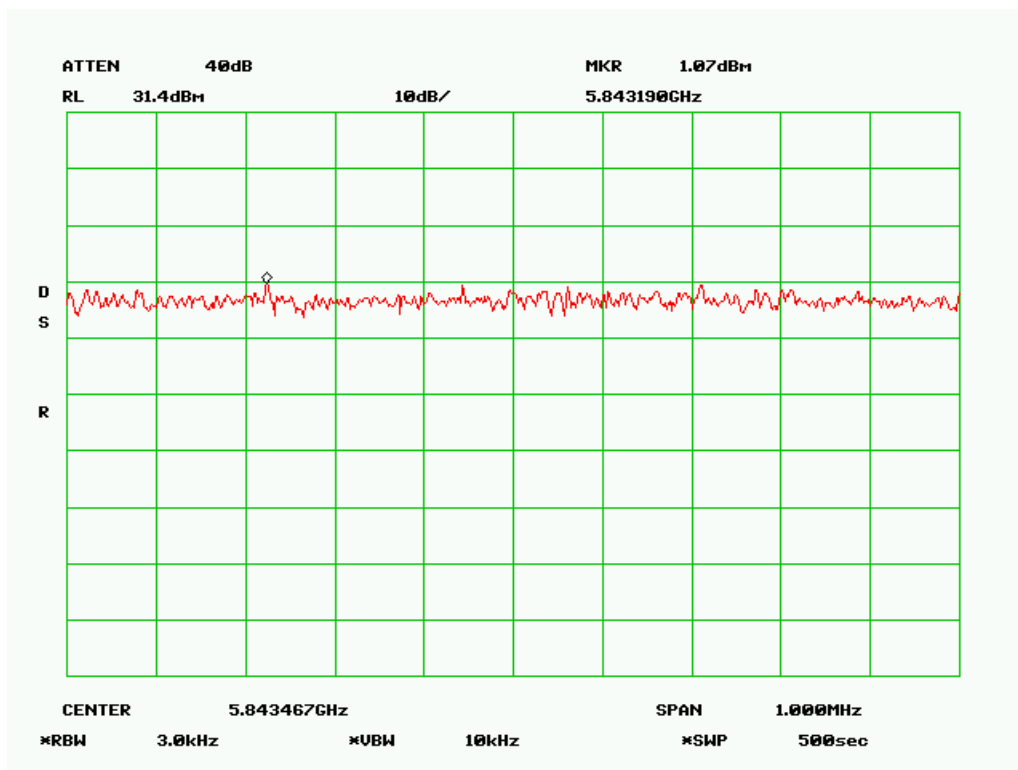

High Channel (8MHz Mode 2)

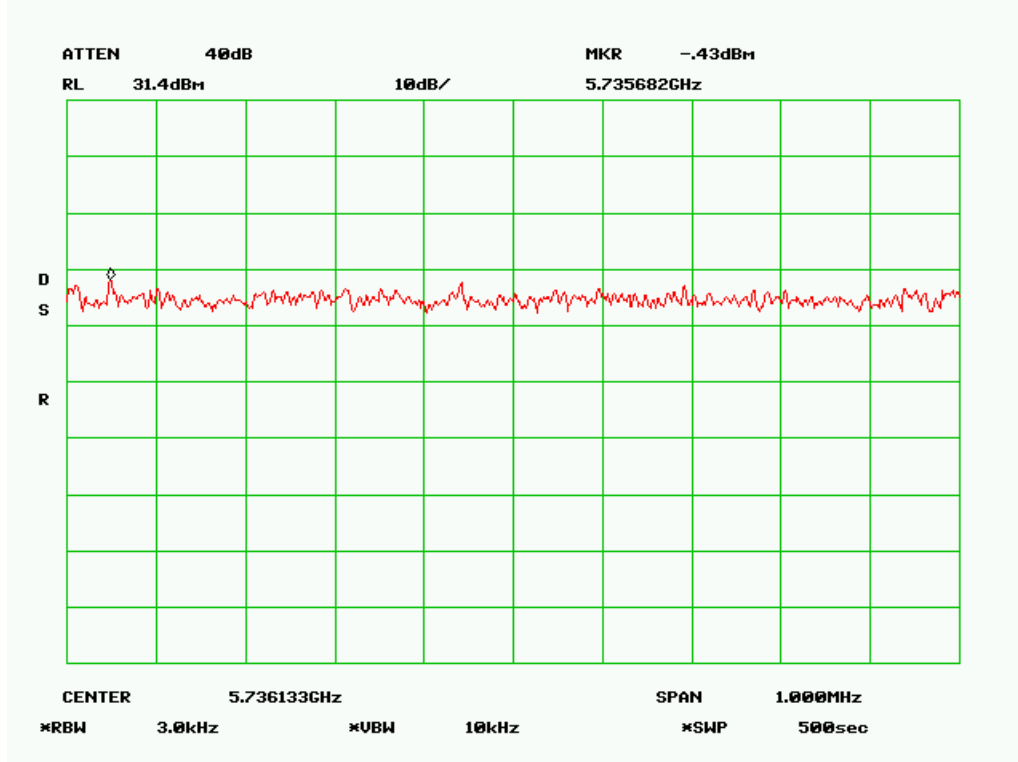

Low Channel (16MHz Mode 2)

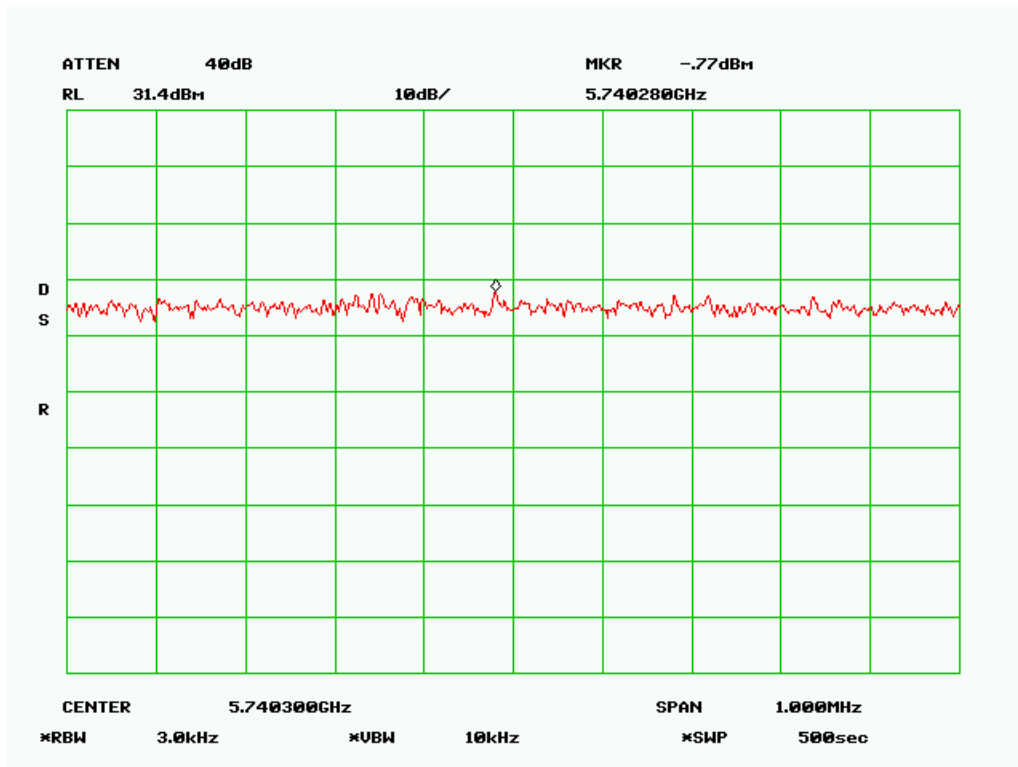

Low Channel (16MHz Mode 3)

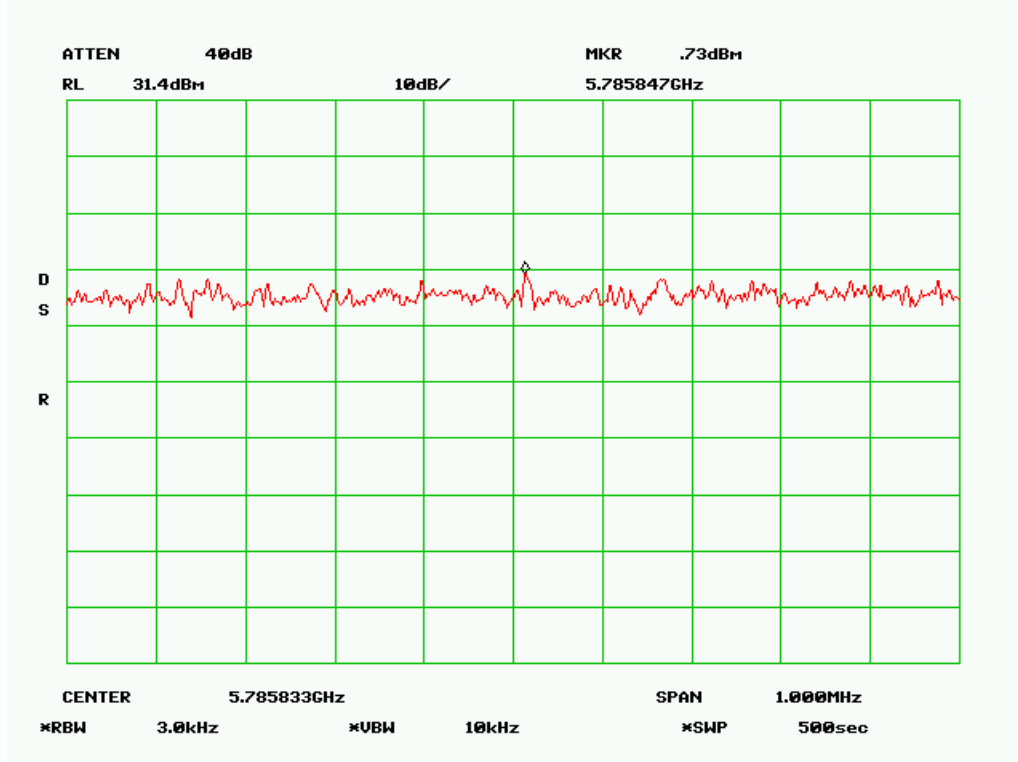

Mid Channel (16MHz Mode 1)

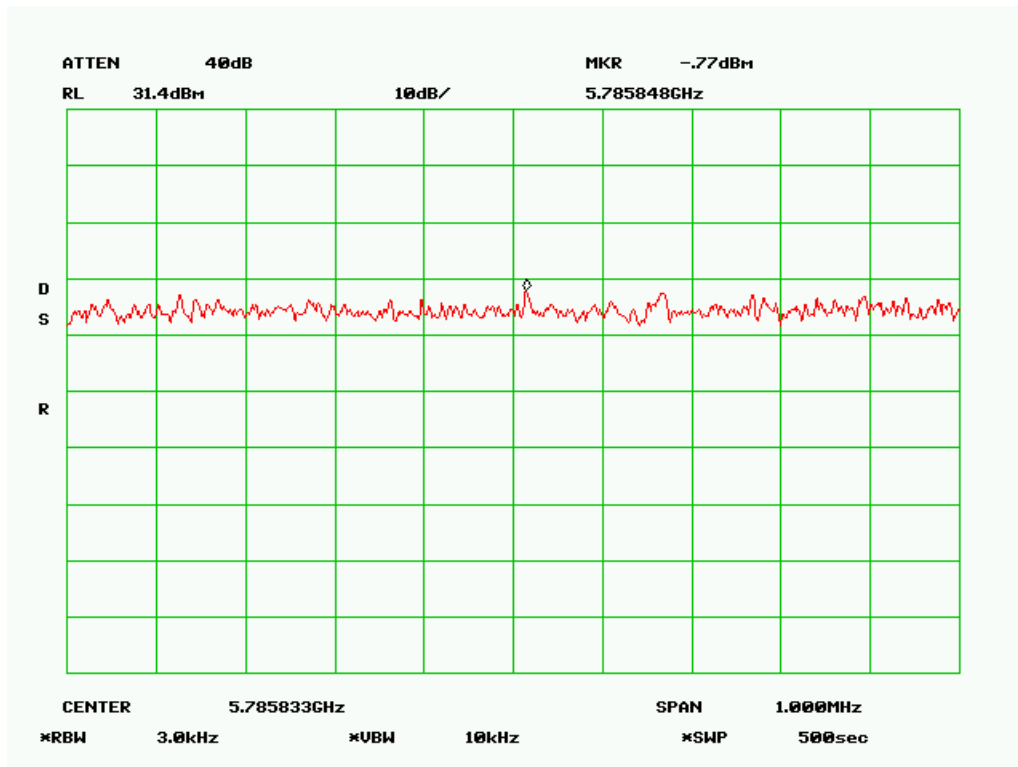

Mid Channel (16MHz Mode 2)

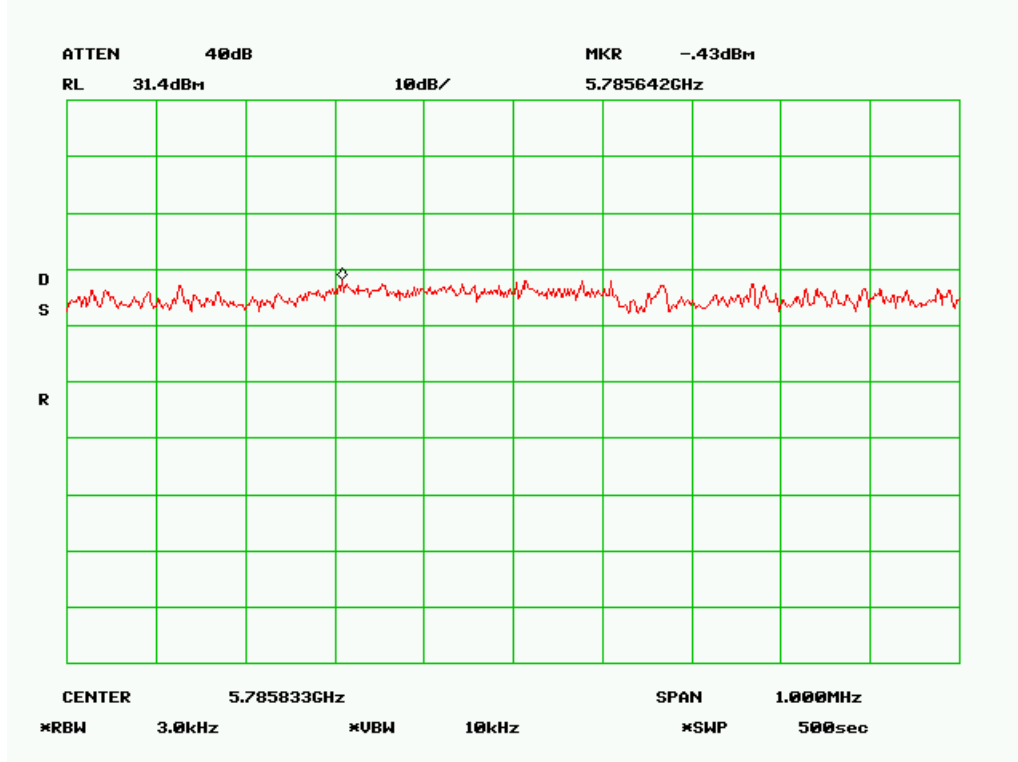

Mid Channel (16MHz Mode 3)

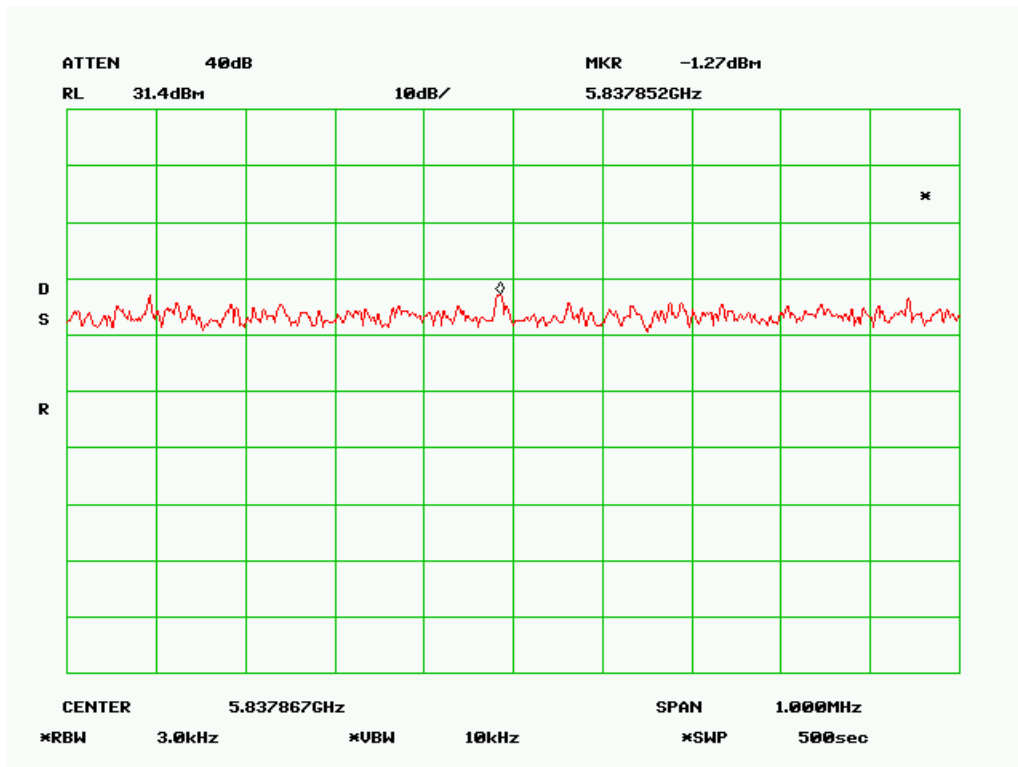

High Channel (16MHz Mode 1)

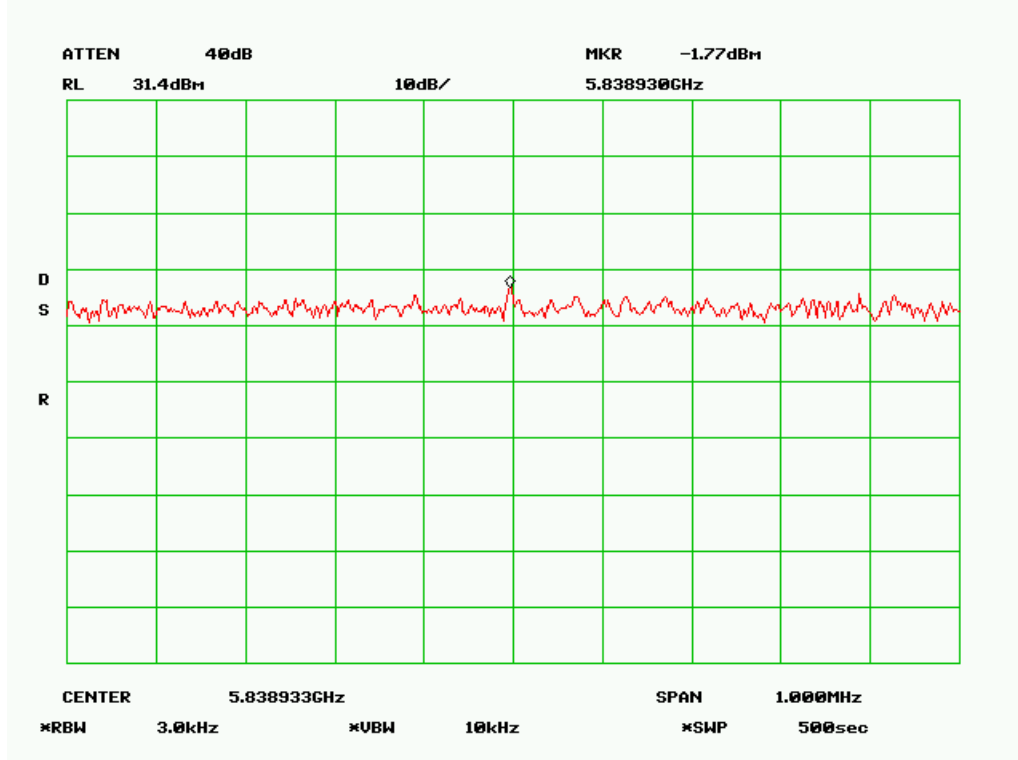

Low Channel (32MHz Mode 1)

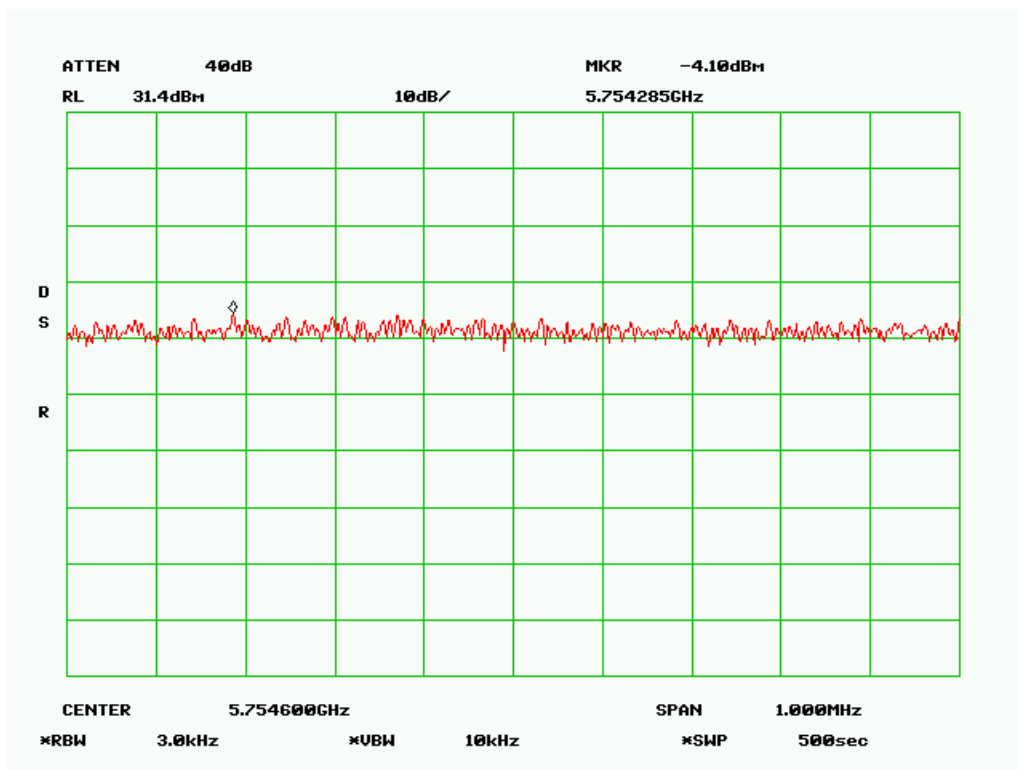

Low Channel (32MHz Mode 2)

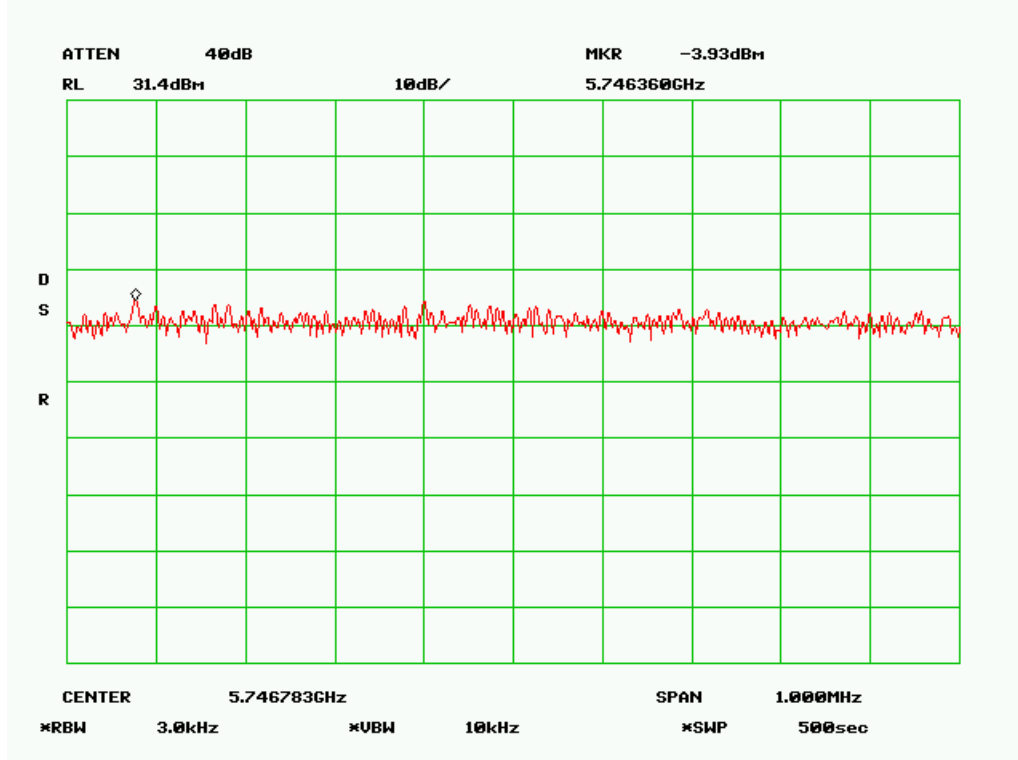

Low Channel (32MHz Mode 3)

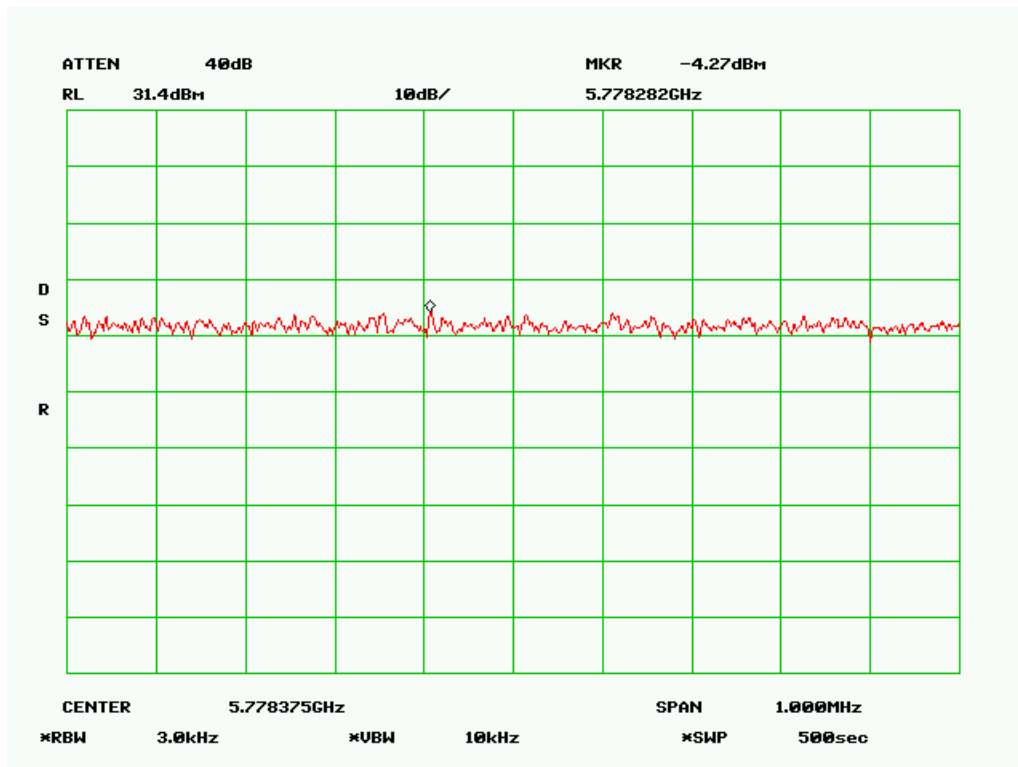

Mid Channel (32MHz Mode 1)

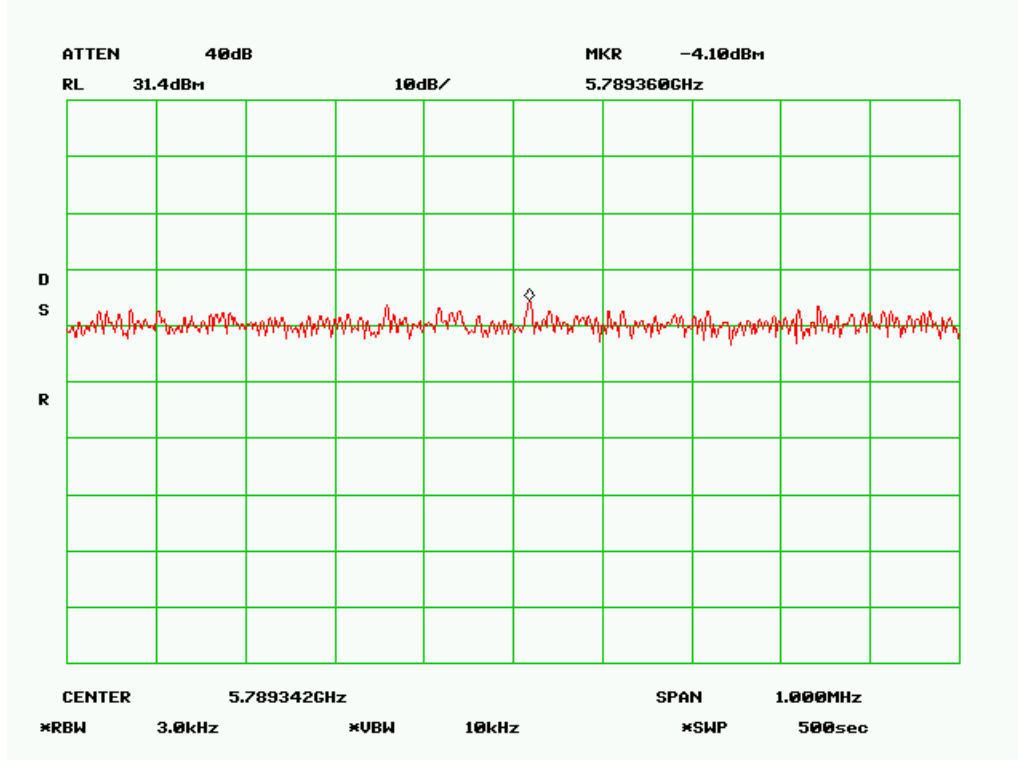

Mid Channel (32MHz Mode 2)

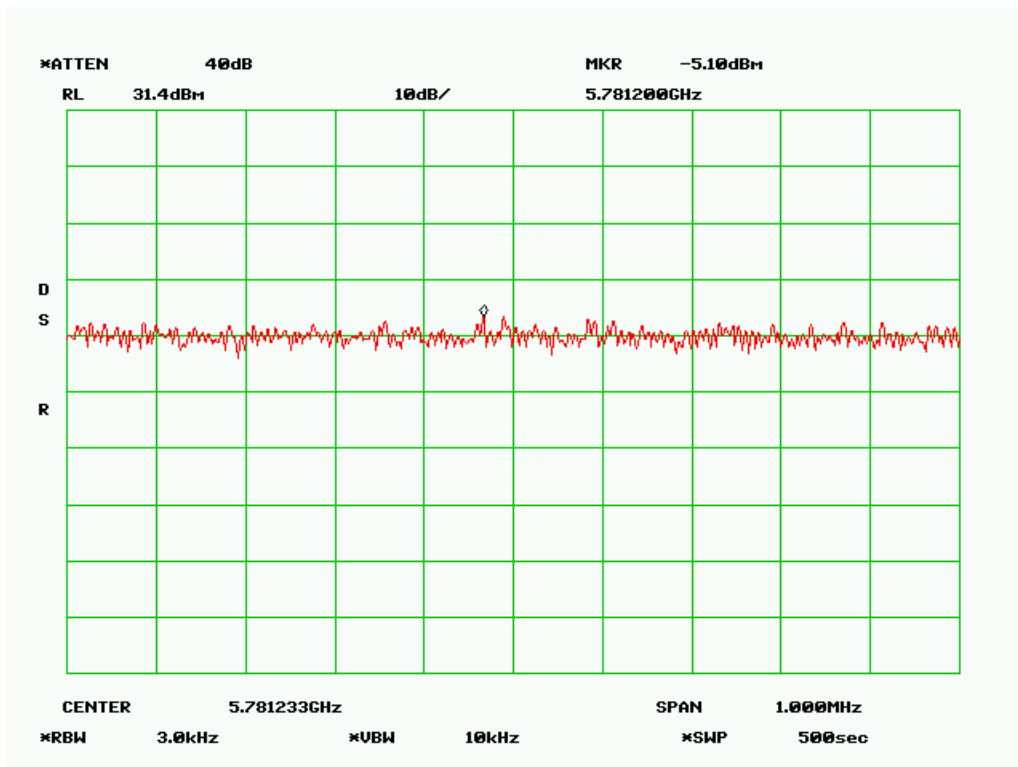

Mid Channel (32MHz Mode 3)

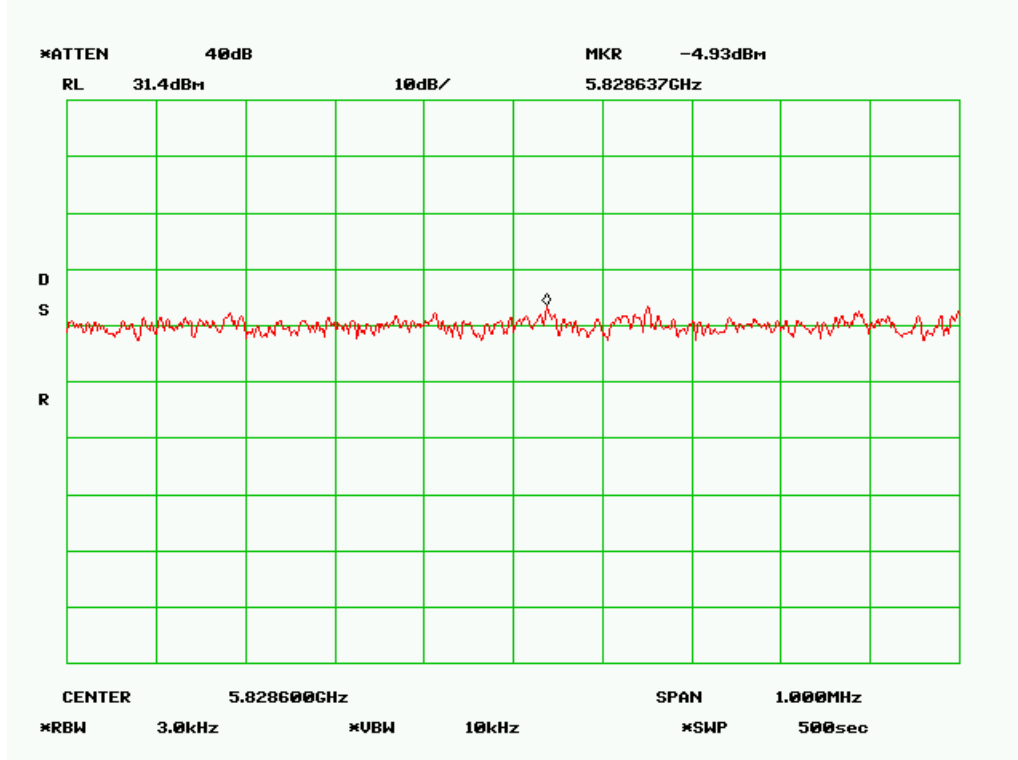

High Channel (32MHz Mode 1)

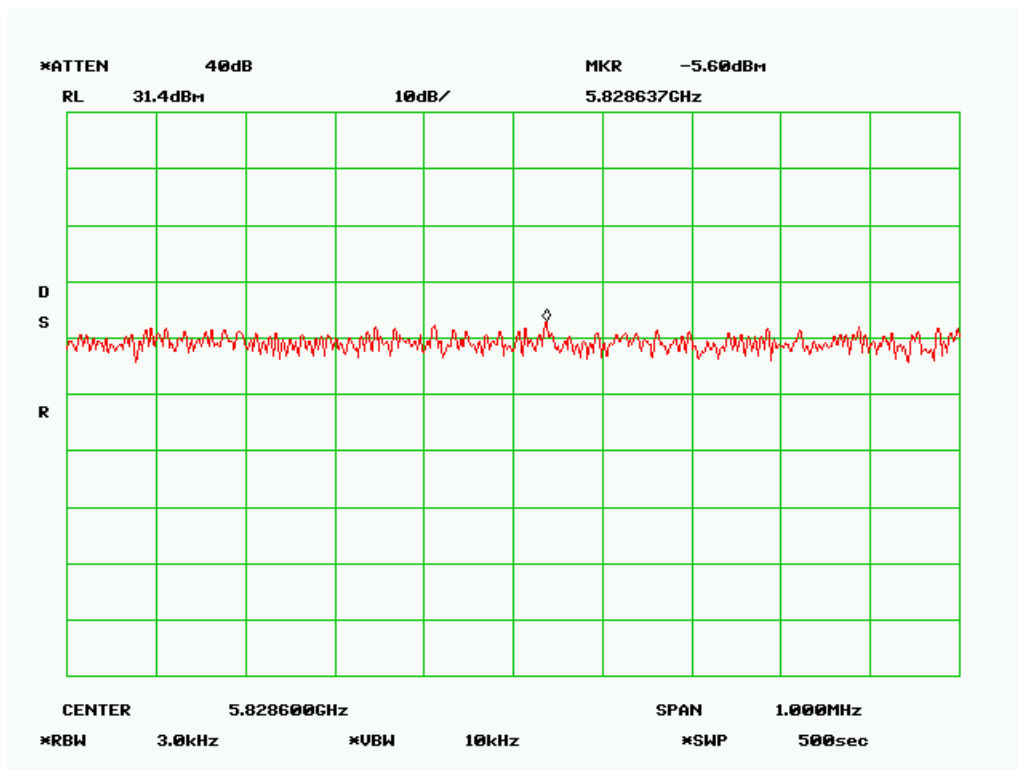

High Channel (32MHz Mode 2)

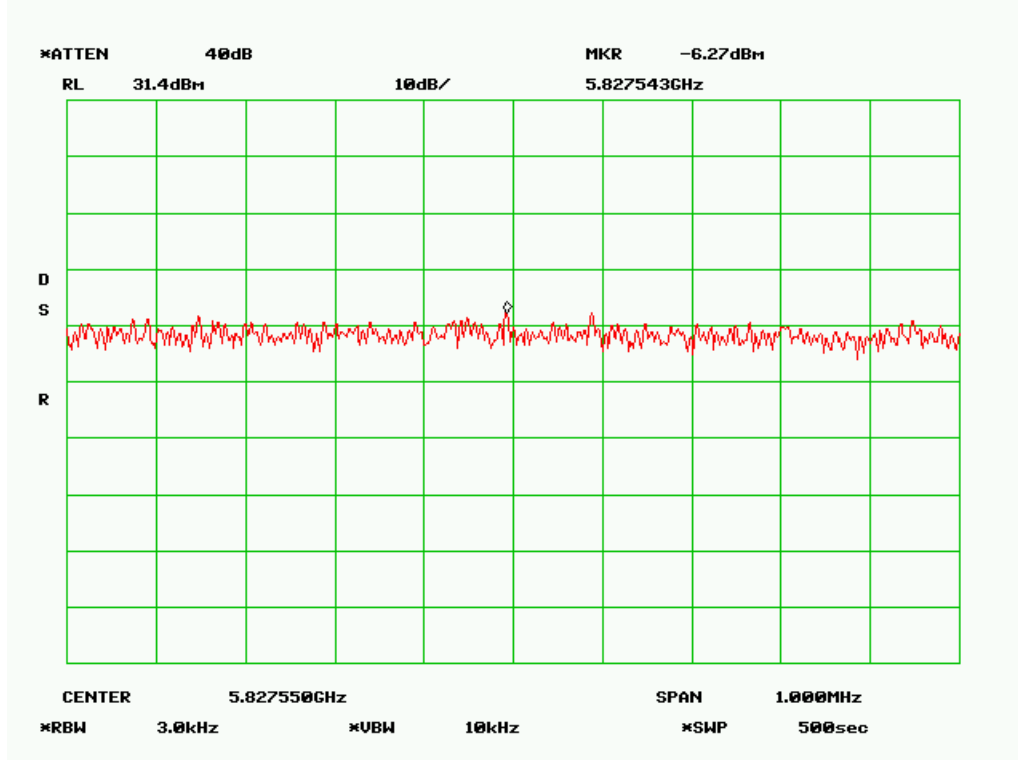

High Channel (32MHz Mode 3)

5.10 Peak Output Power

1. Conducted Measurement
 EUT was set for low , mid, high channel with modulated mode and highest RF output power.
 The spectrum analyzer was connected to the antenna terminal.
2. Conducted Emissions Measurement Uncertainty
 All test measurements carried out are traceable to national standards. The uncertainty of the measurement at a confidence level of approximately 95% (in the case where distributions are normal), with a coverage factor of 2, in the range 30MHz – 40GHz is $\pm 1.5\text{dB}$.
3. Environmental Conditions

Temperature	23°C
Relative Humidity	50%
Atmospheric Pressure	1019mbar
4. Test Date : July 10-21 2009
 Tested By :Choon Sian Ooi

Standard Requirement: 47 CFR §15.247(b); RSS210 (A8.4)

Procedures: The peak output power was measured conducted using a spectrum analyzer at low, mid, and hi channels. Sample detector was set to measure the power output.

Note: Systems operating in the 5725–5850 MHz band that are used exclusively for fixed, point-to-point operations may employ transmitting antennas with directional gain greater than 6 dBi without any corresponding reduction in transmitter peak output power

Test Result:

Channel	Channel Bandwidth	Mode	Power (dBm)	Limit (dBm)
Low Channel	8MHz	1	24.1	30dbm
	8MHz	2	24.3	
	8MHz	3	24.4	
Mid Channel	8MHz	1	24.2	
	8MHz	2	23.8	
	8MHz	3	23.6	
High Channel	8MHz	1	23.1	
	8MHz	2	23.8	
	8MHz	3	22.2	



Channel	Channel Bandwidth	Mode	Power (dBm)	Limit (dBm)
Low Channel	16MHz	1	24.9	30dBm
	16MHz	2	24.3	
	16MHz	3	24.1	
Mid Channel	16MHz	1	24.8	
	16MHz	2	23.8	
	16MHz	3	23.1	
High Channel	16MHz	1	23.1	
	16MHz	2	21.6	
	16MHz	3	22.5	

Channel	Channel Bandwidth	Mode	Power (dBm)	Limit (dBm)
Low Channel	32MHz	1	24.9	30dBm
	32MHz	2	23.1	
	32MHz	3	24.2	
Mid Channel	32MHz	1	23.0	
	32MHz	2	23.2	
	32MHz	3	22.5	
High Channel	32MHz	1	23.2	
	32MHz	2	22.4	
	32MHz	3	21.9	

Refer to the attached plots.

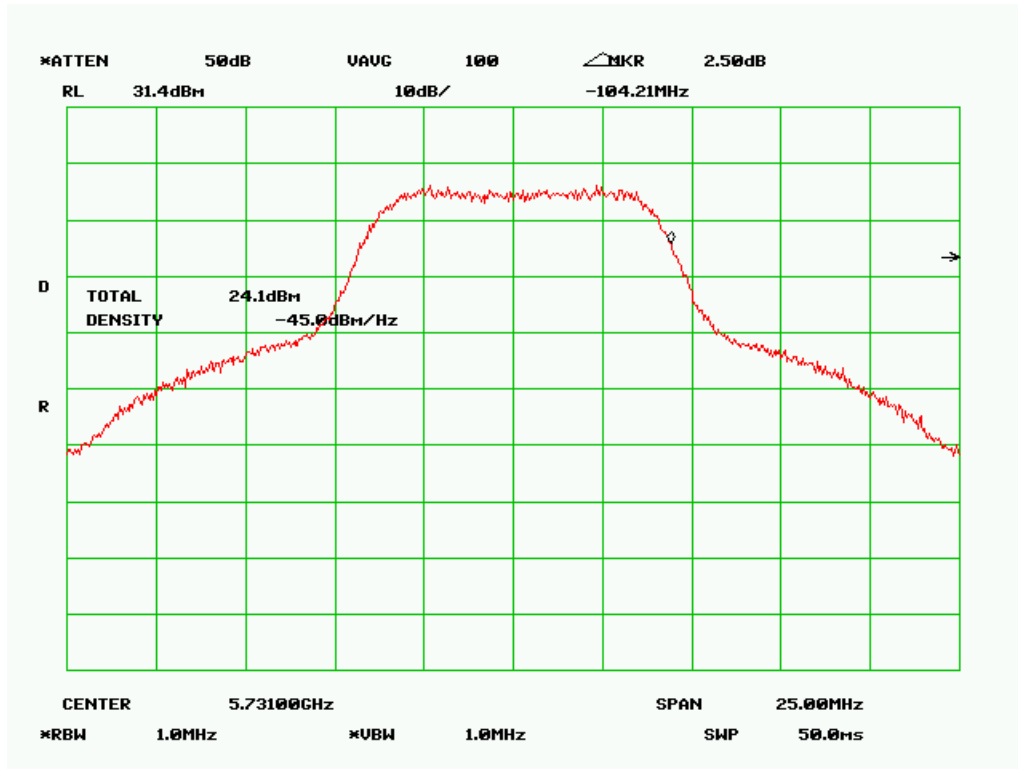

Low Channel (8MHz Mode 1)

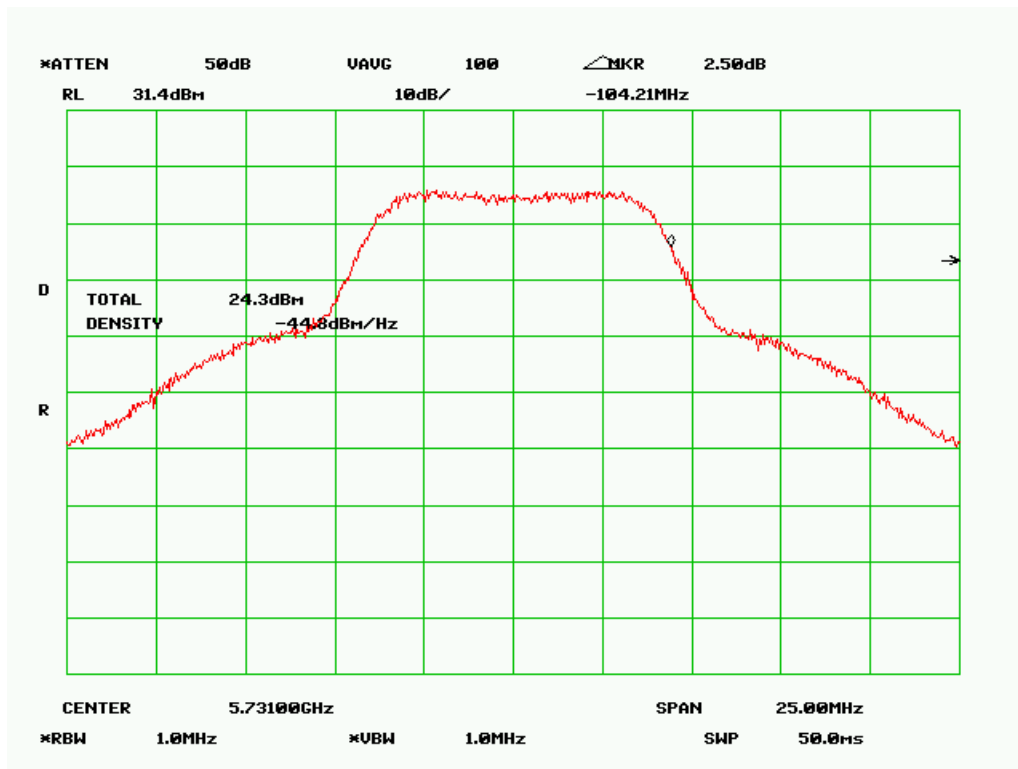

Low Channel (8MHz Mode 2)

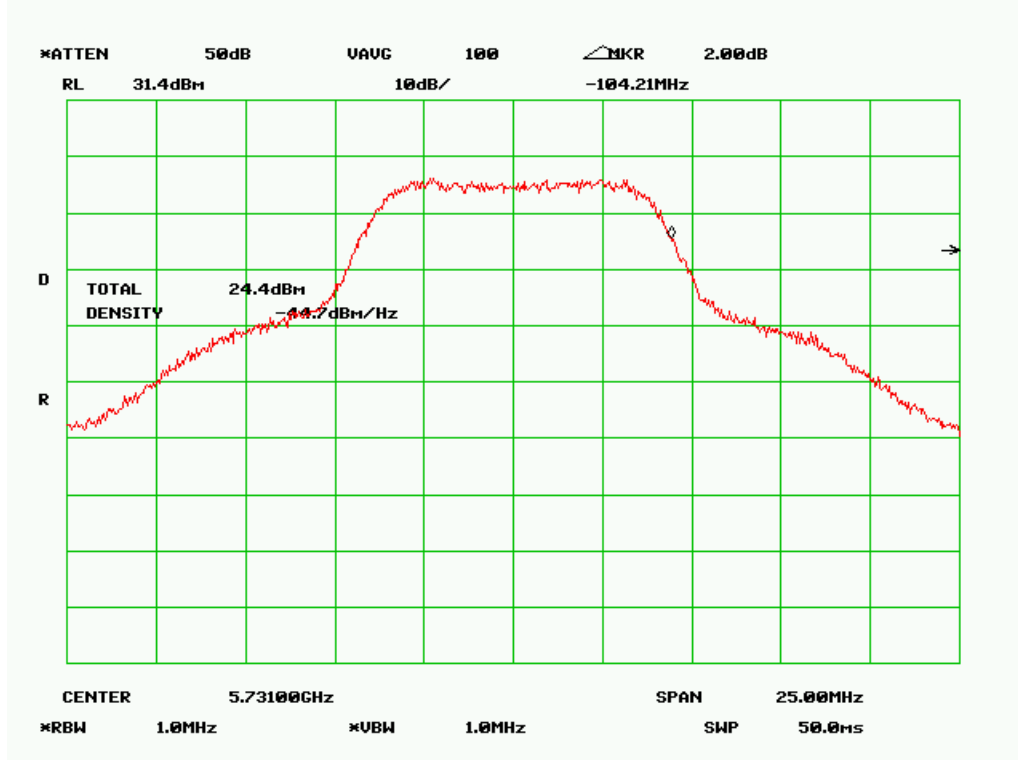

Low Channel (8MHz Mode 3)

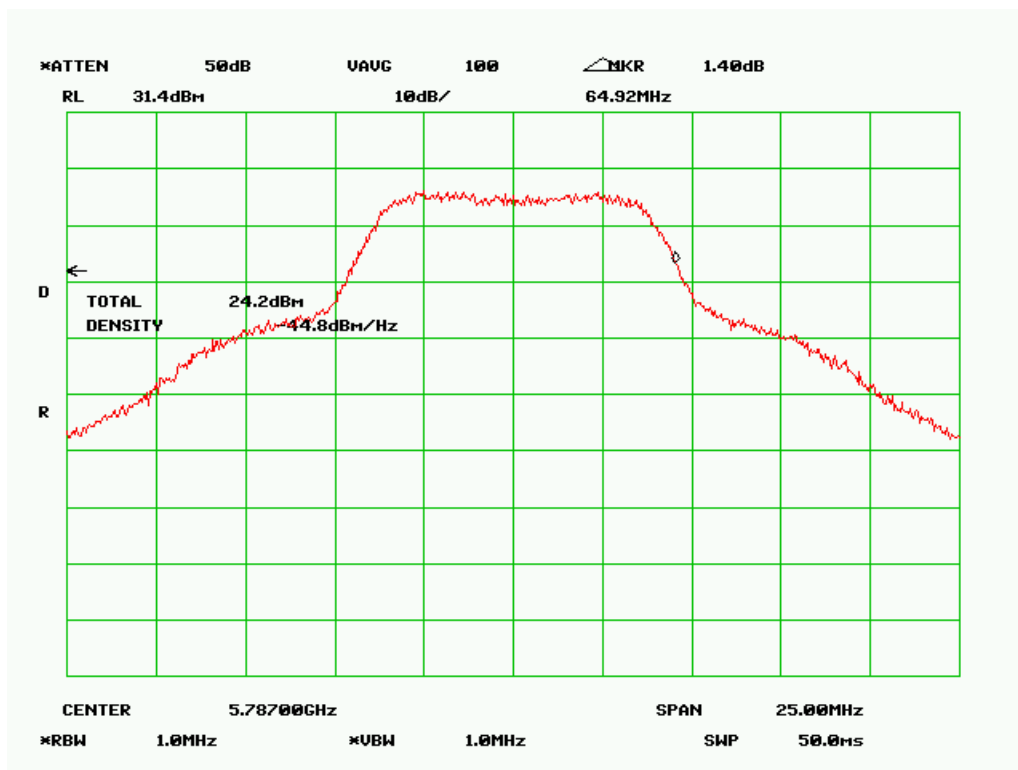

Mid Channel (8MHz Mode 1)

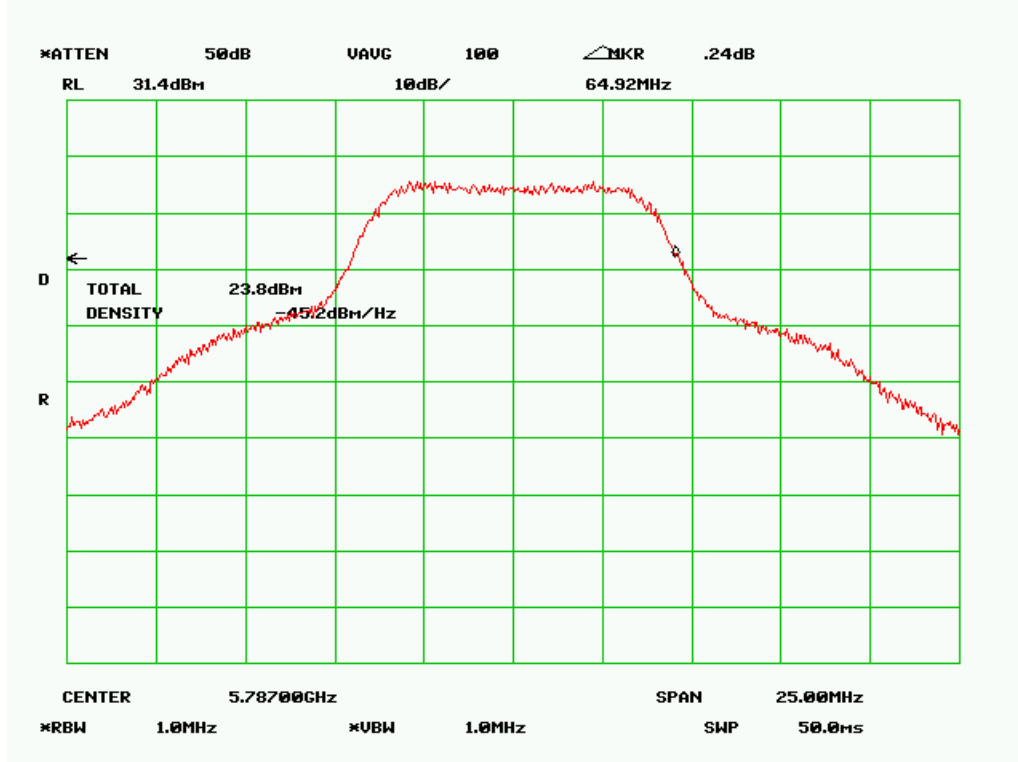

Mid Channel (8MHz Mode 2)

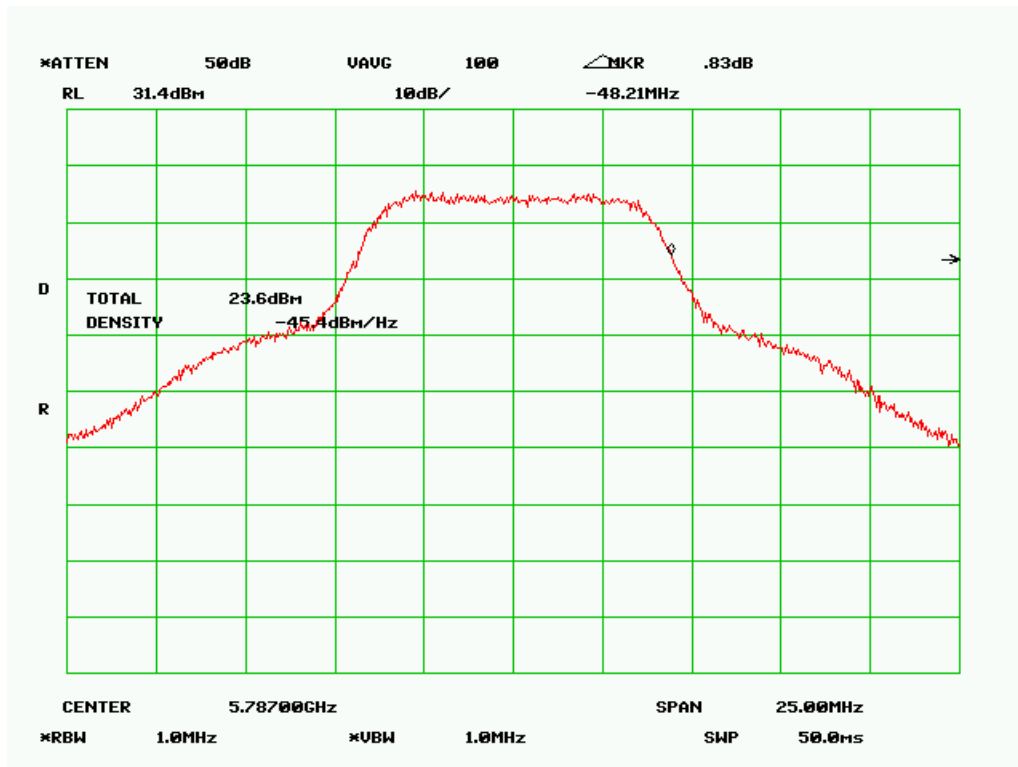

Mid Channel (8MHz Mode 3)

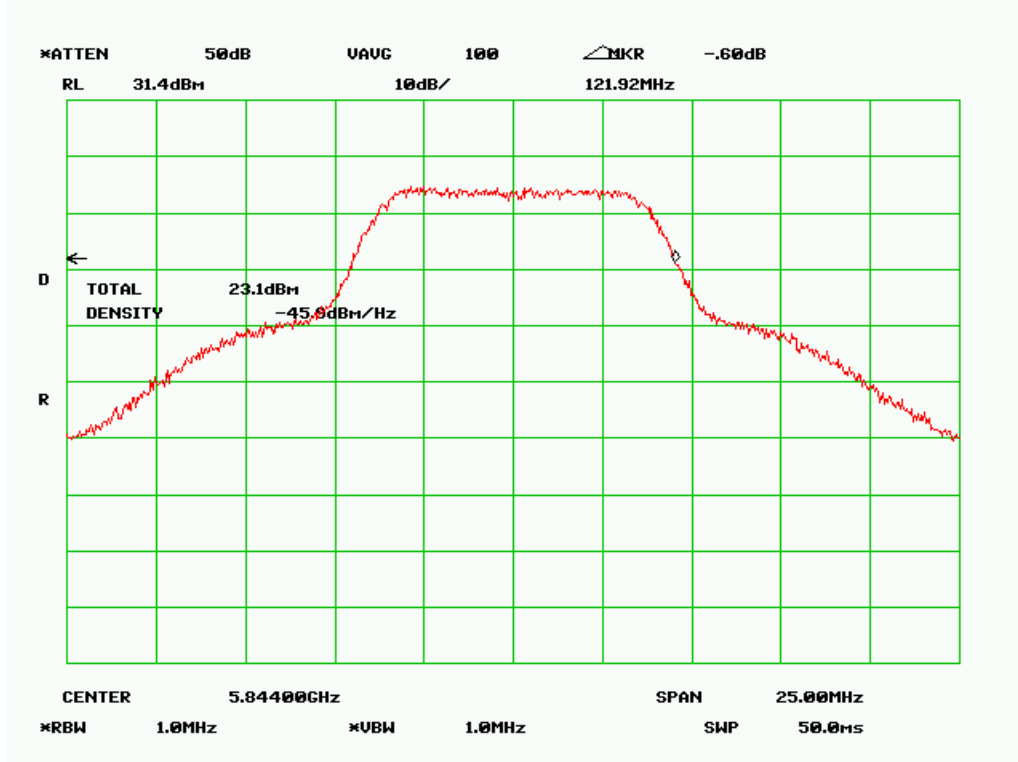

High Channel (8MHz Mode 1)

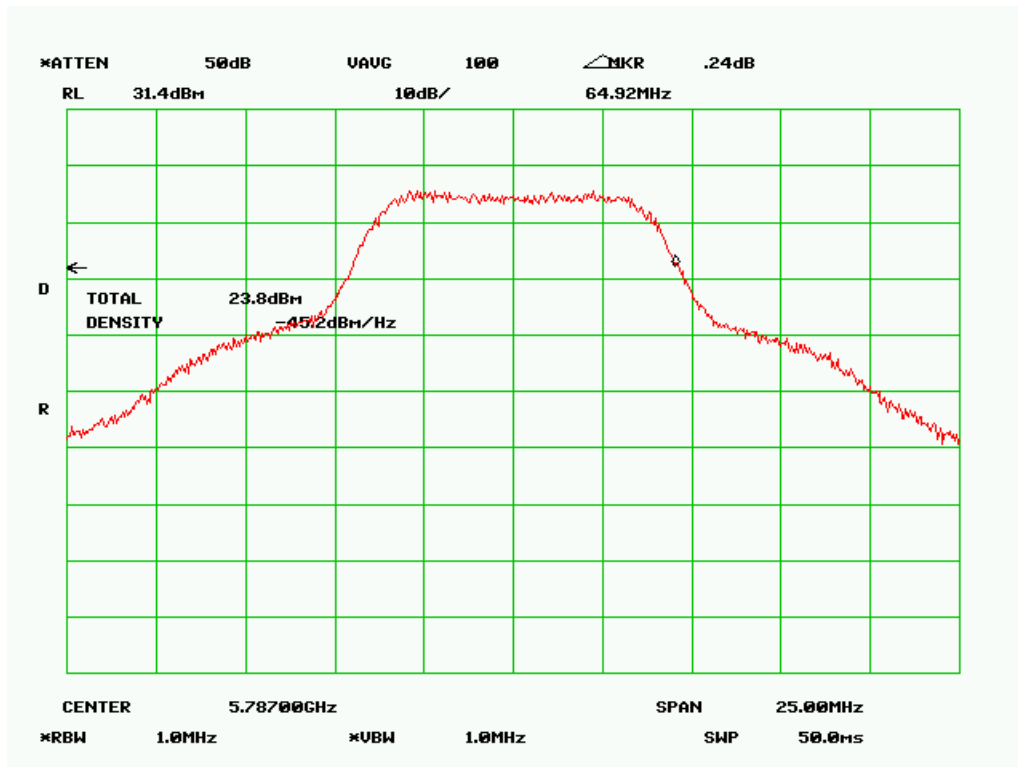

High Channel (8MHz Mode 2)

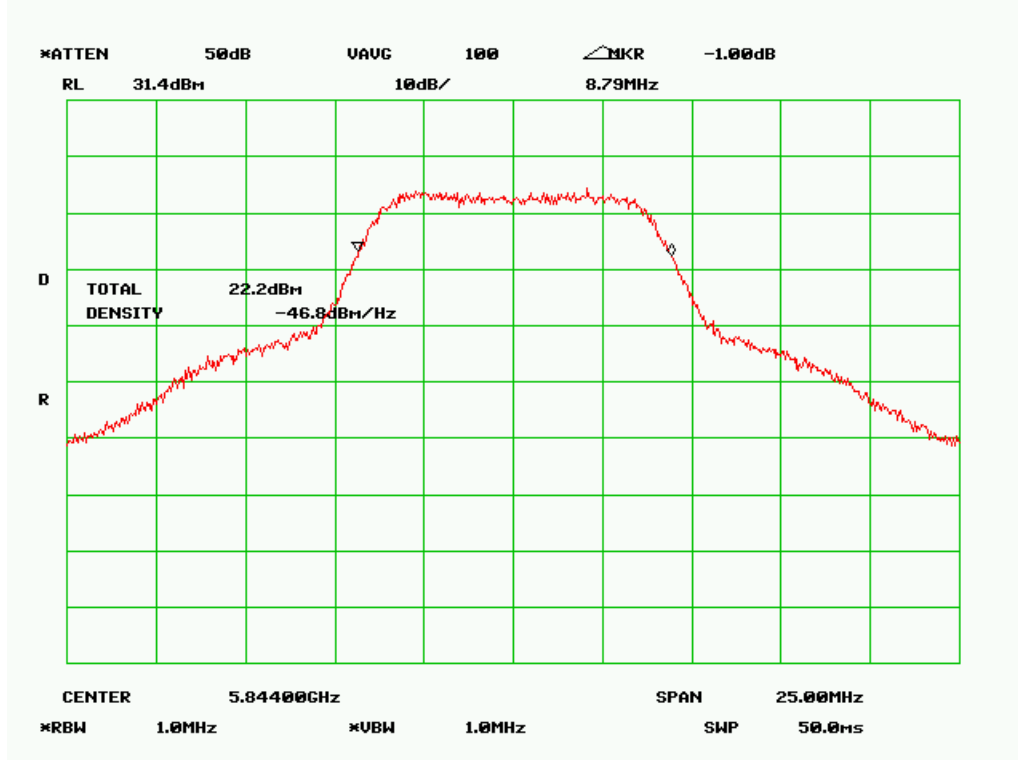

High Channel (8MHz Mode 3)

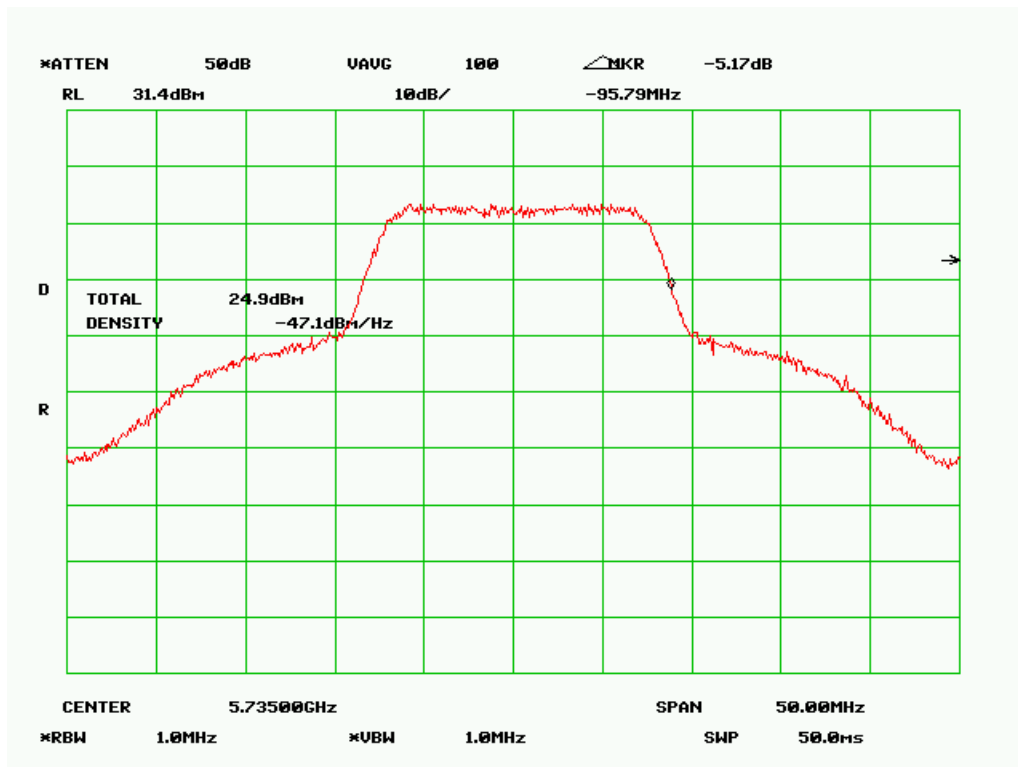

Low Channel (16MHz Mode 1)

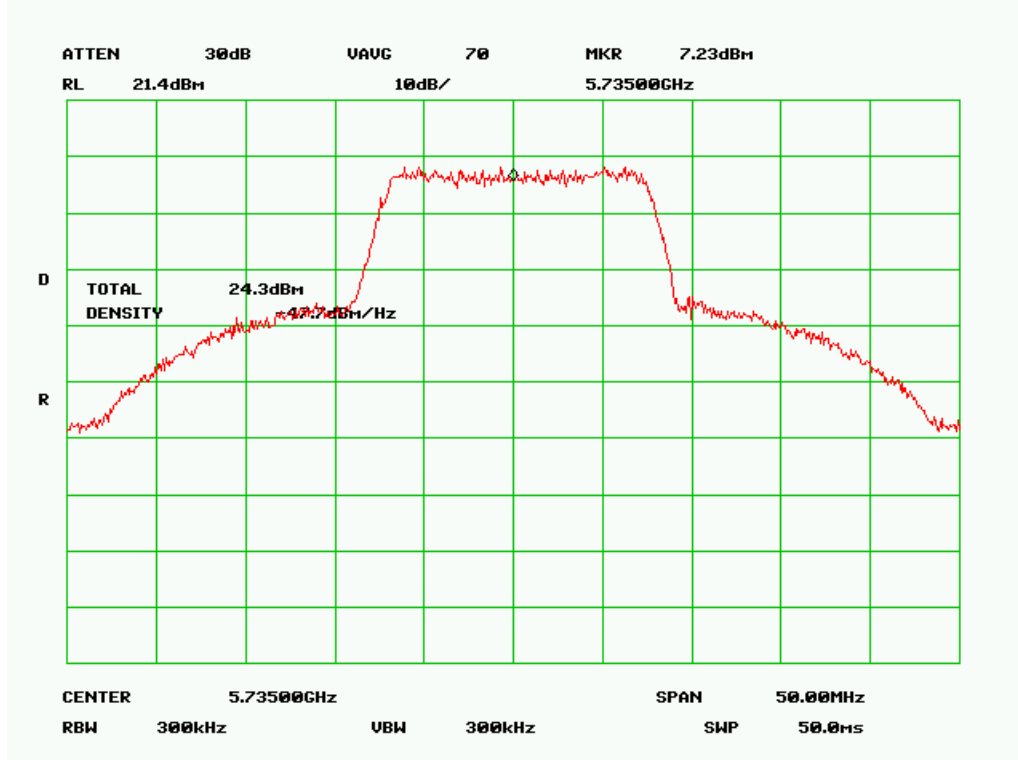

Low Channel (16MHz Mode 2)

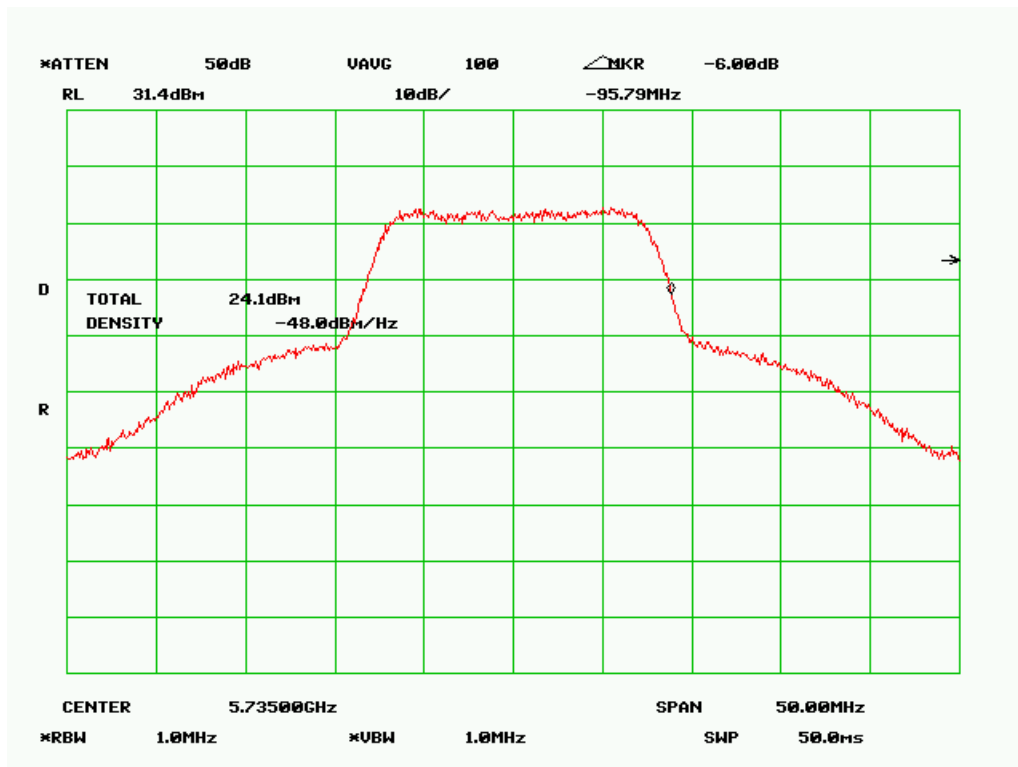

Low Channel (16MHz Mode 3)

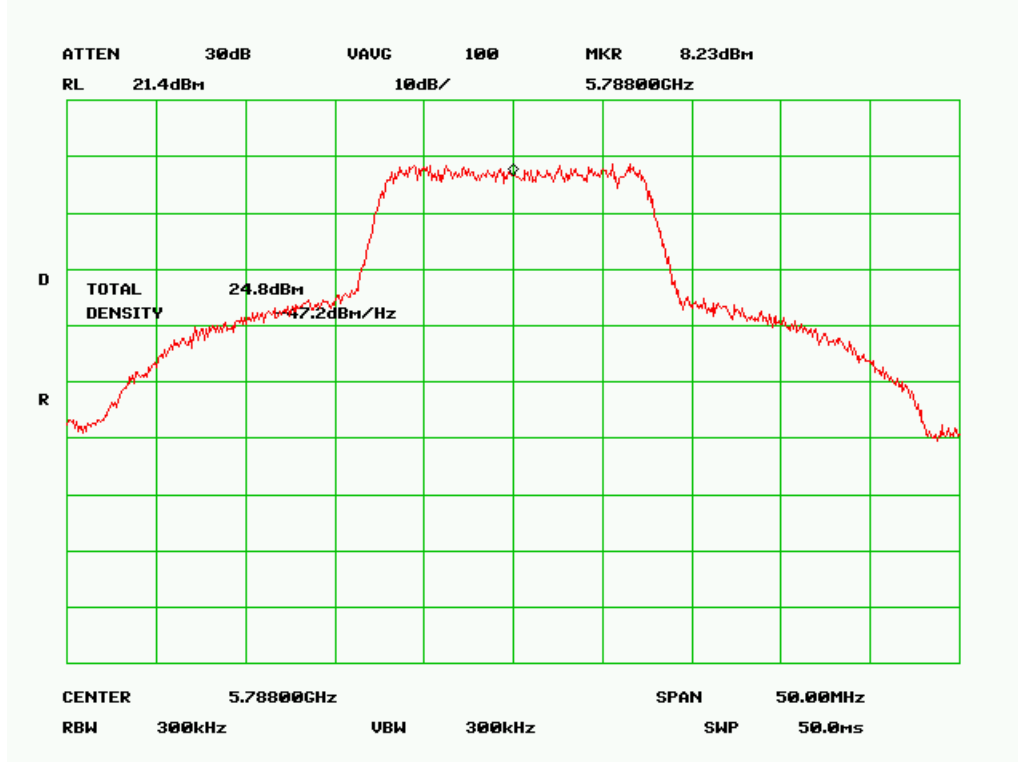

Mid Channel (16MHz Mode 1)

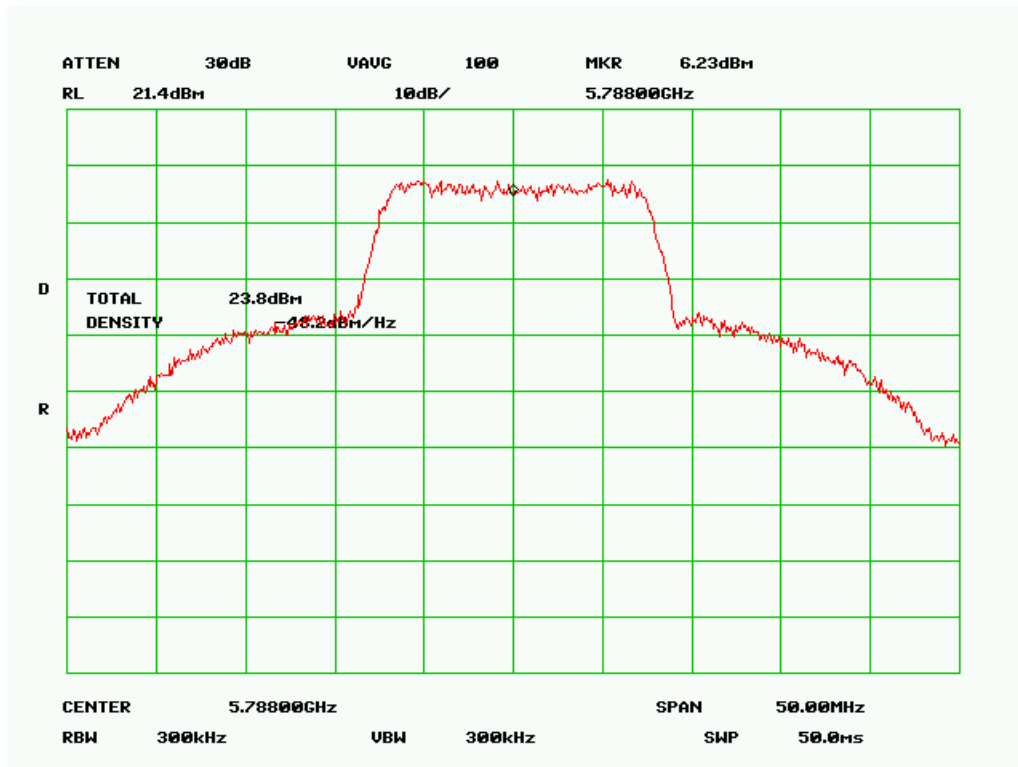

Mid Channel (16MHz Mode 2)

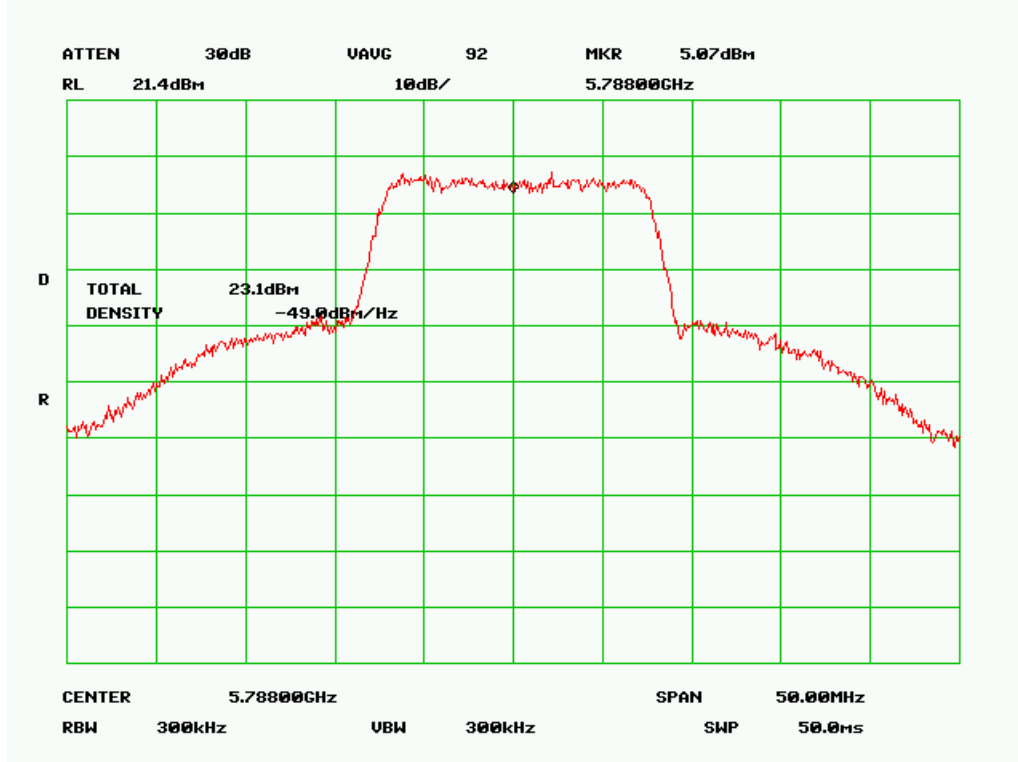

Mid Channel (16MHz Mode 3)

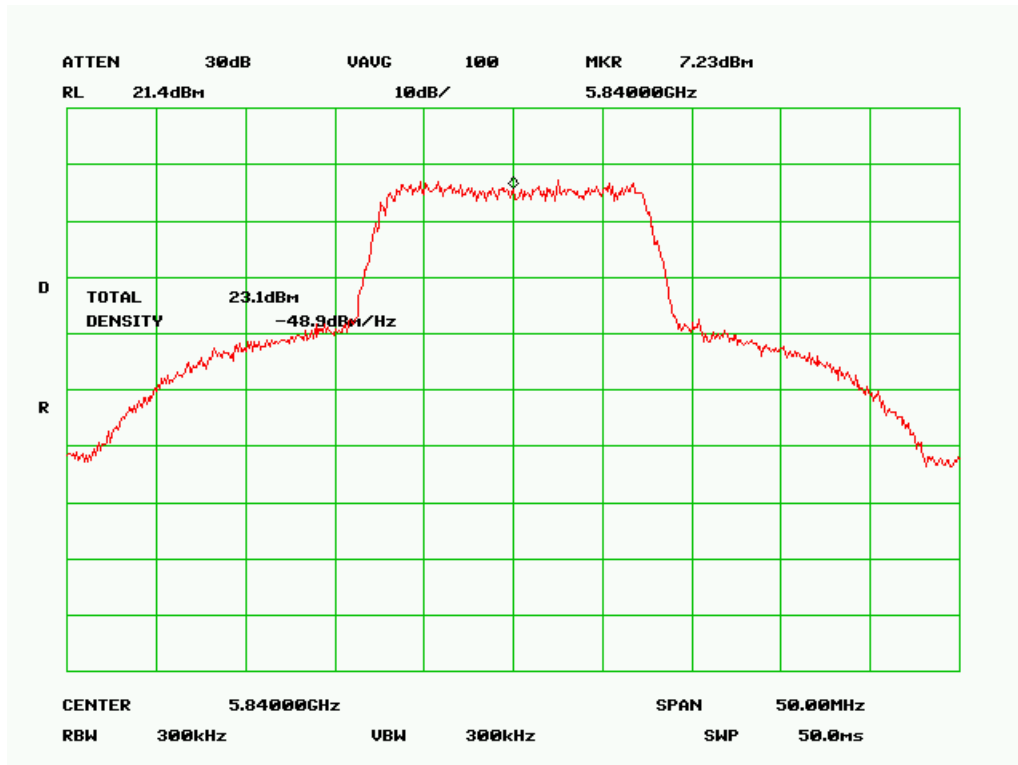

High Channel (16MHz Mode 1)

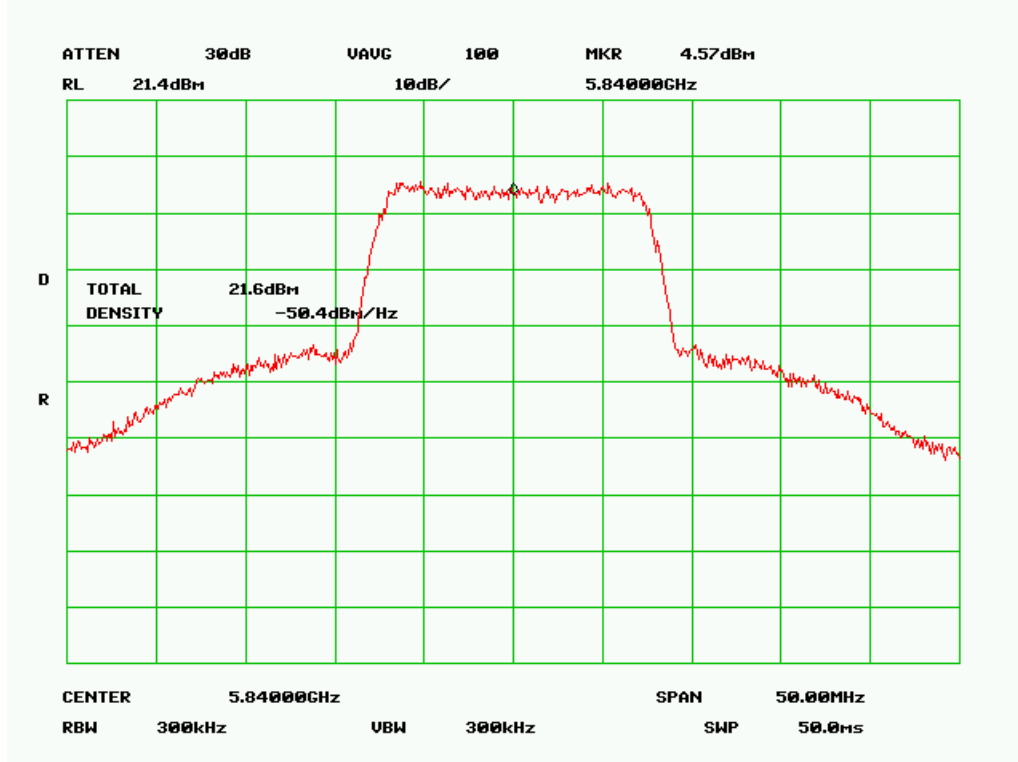

High Channel (16MHz Mode 2)

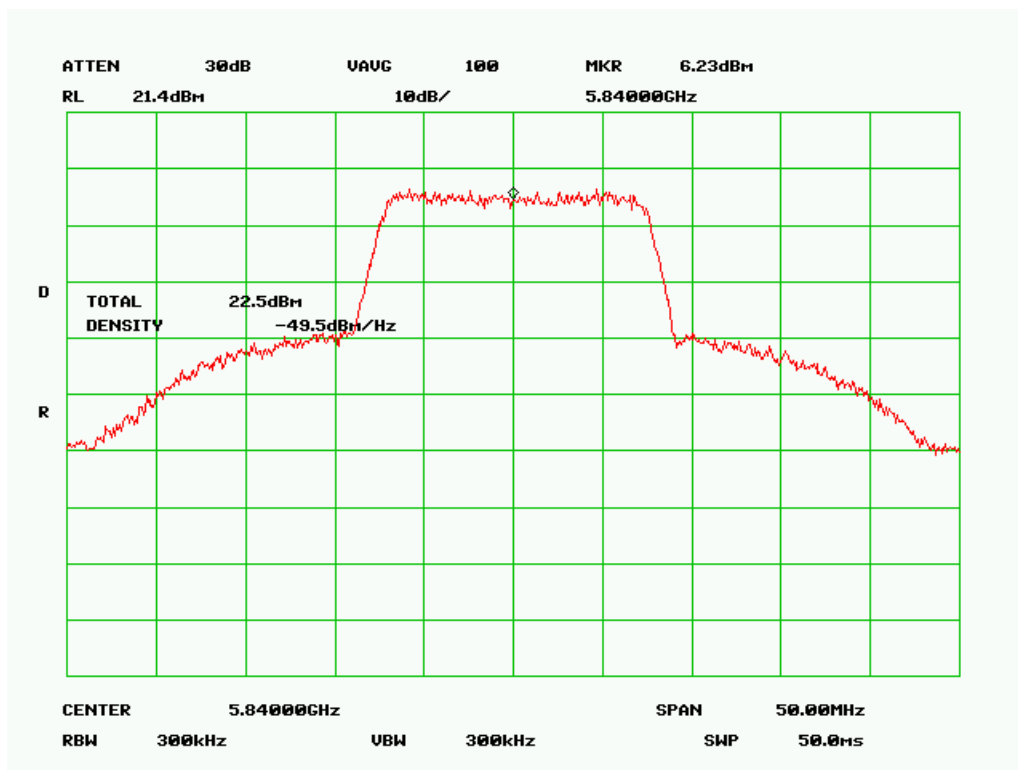

High Channel (16MHz Mode 3)

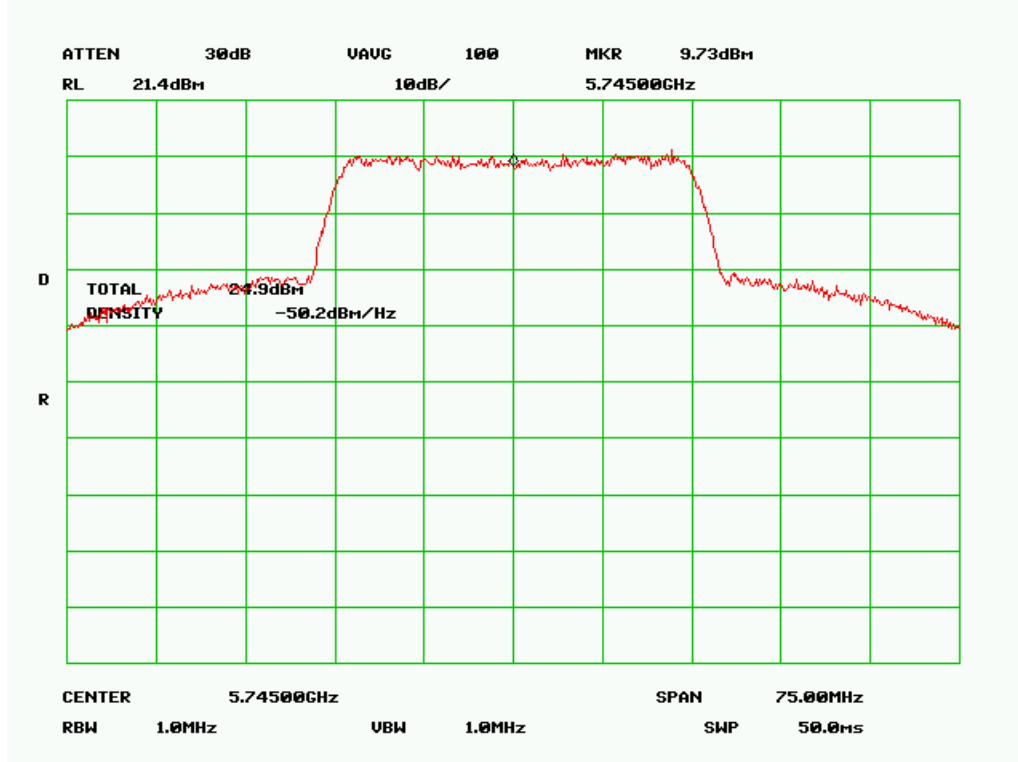

Low Channel (32MHz Mode 1)

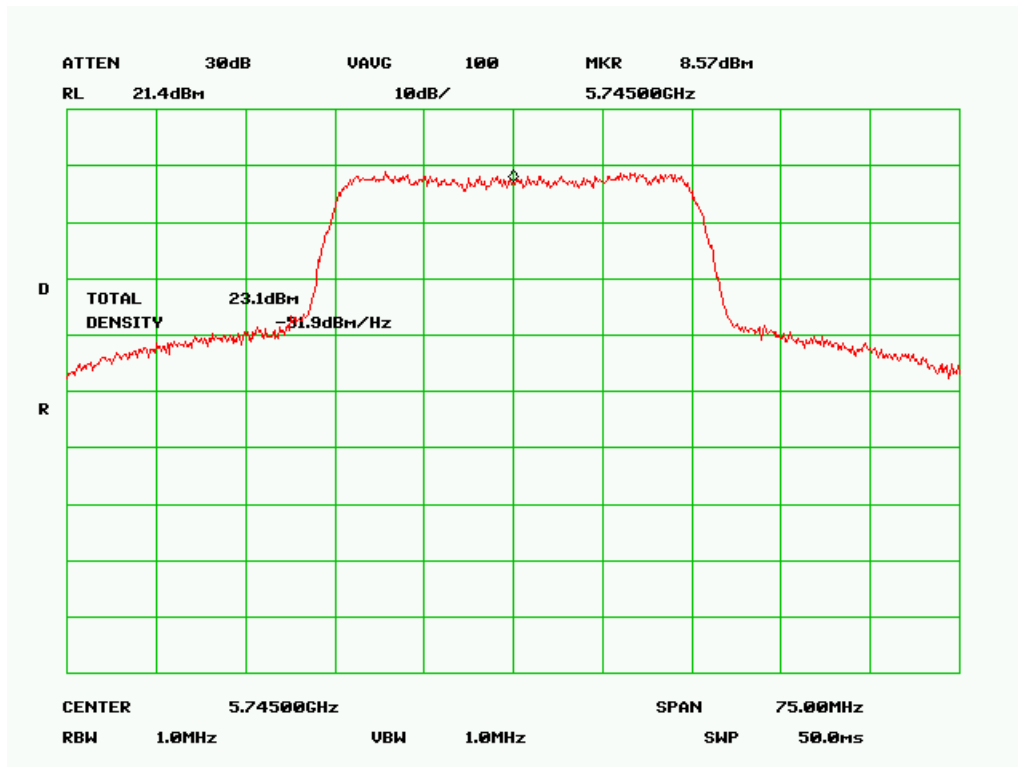

Low Channel (32MHz Mode 2)

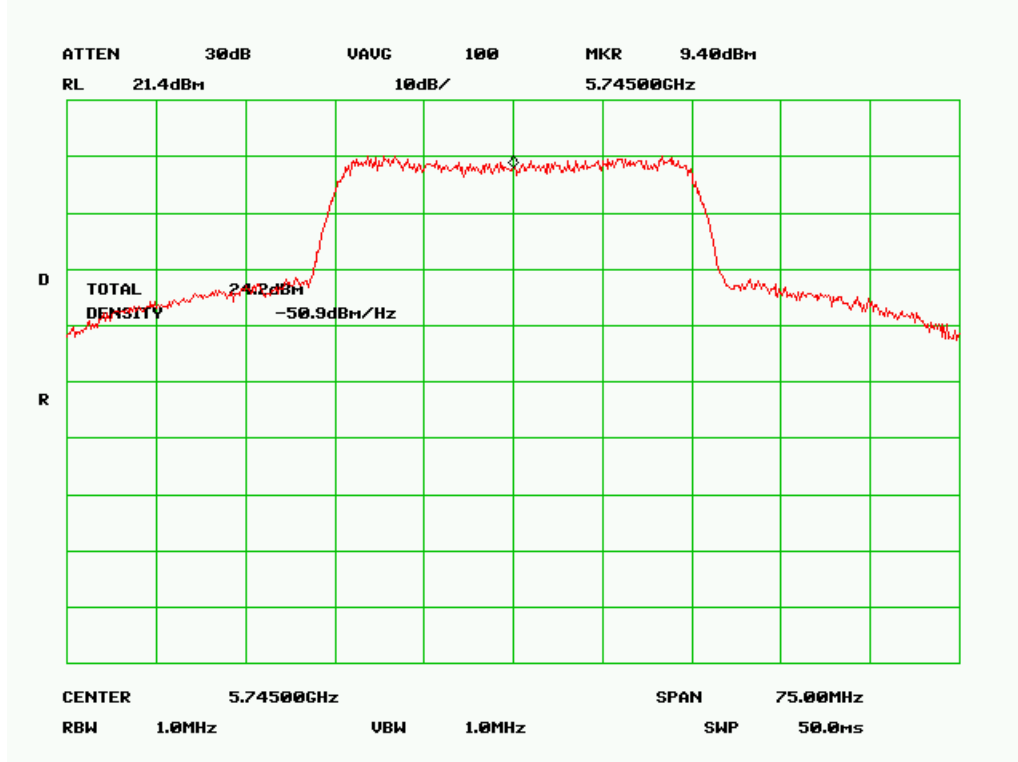

Low Channel (32MHz Mode 3)

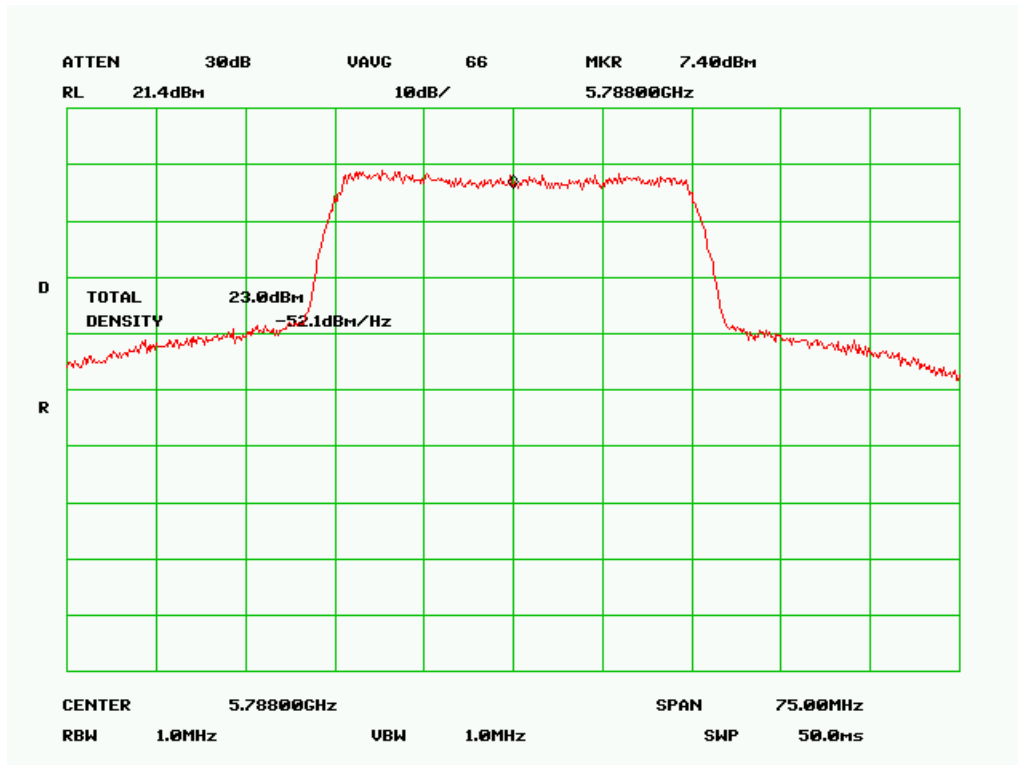

Mid Channel (32MHz Mode 1)

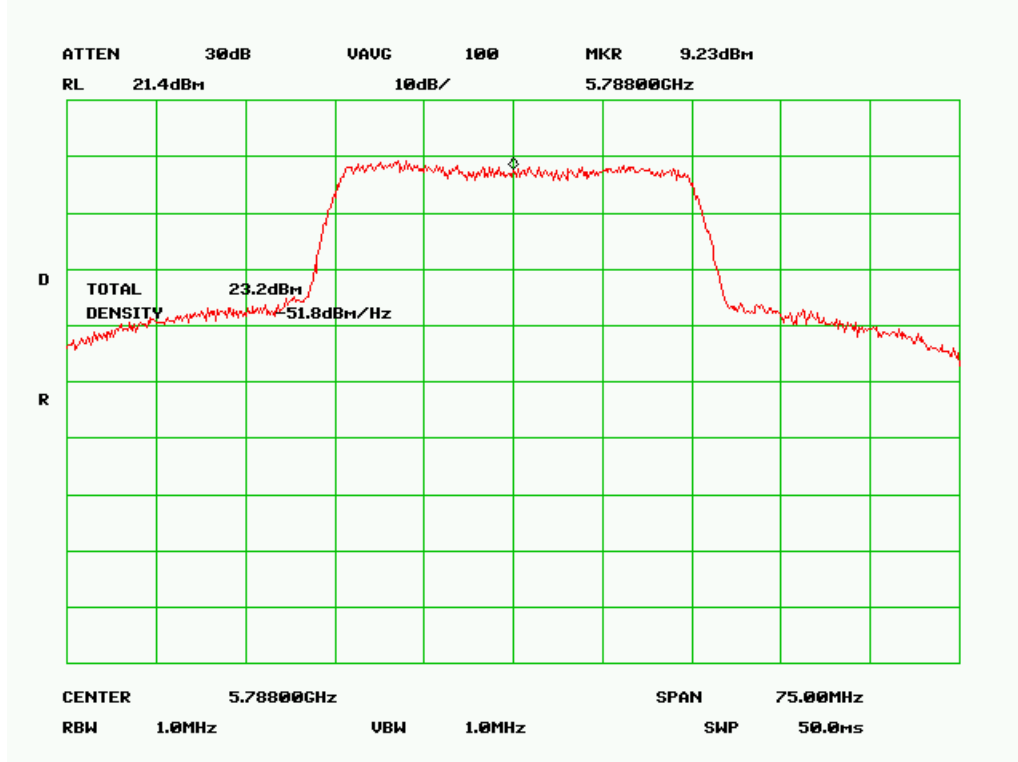

Mid Channel (32MHz Mode 2)

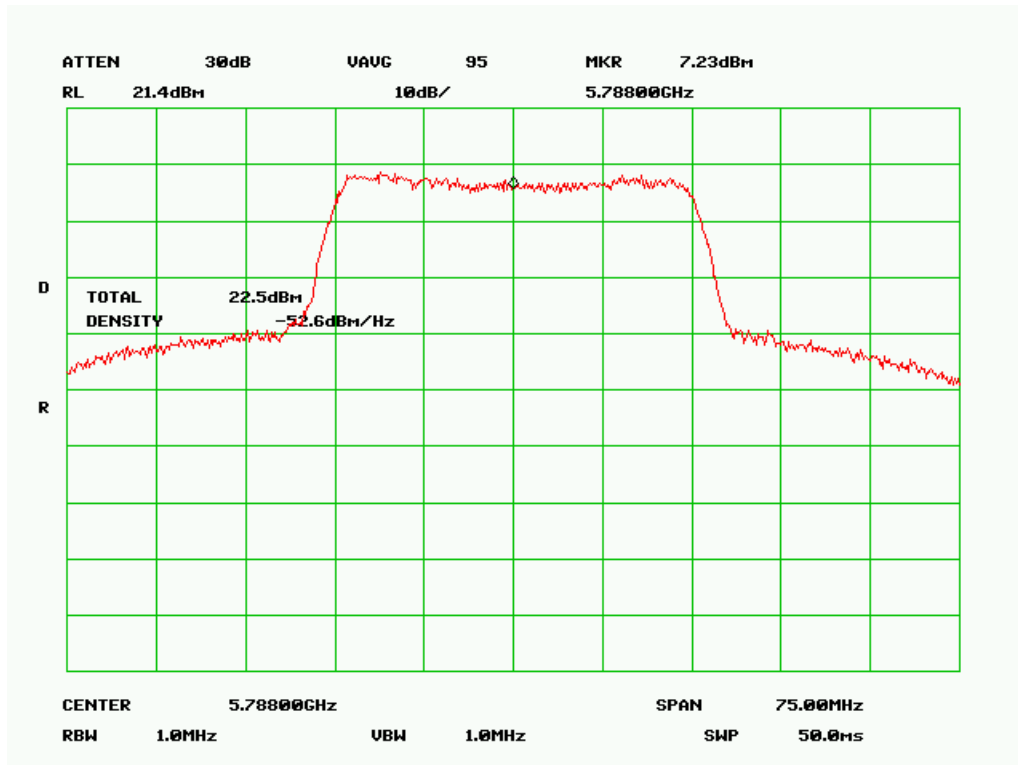

Mid Channel (32MHz Mode 3)

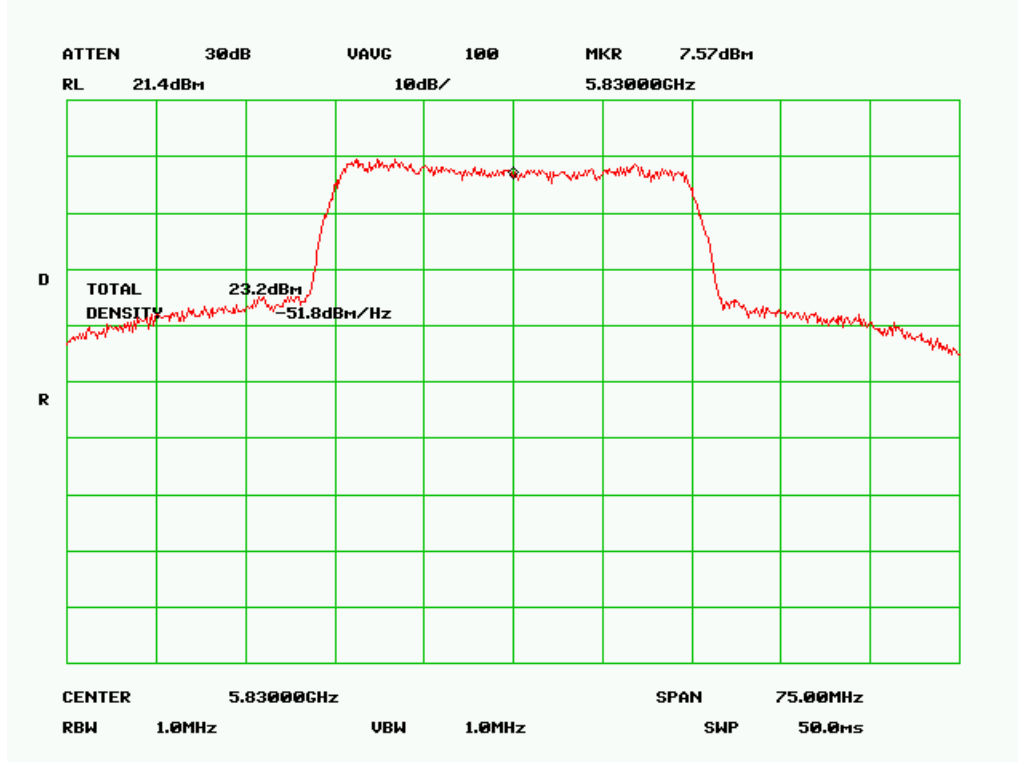

High Channel (32MHz Mode 1)

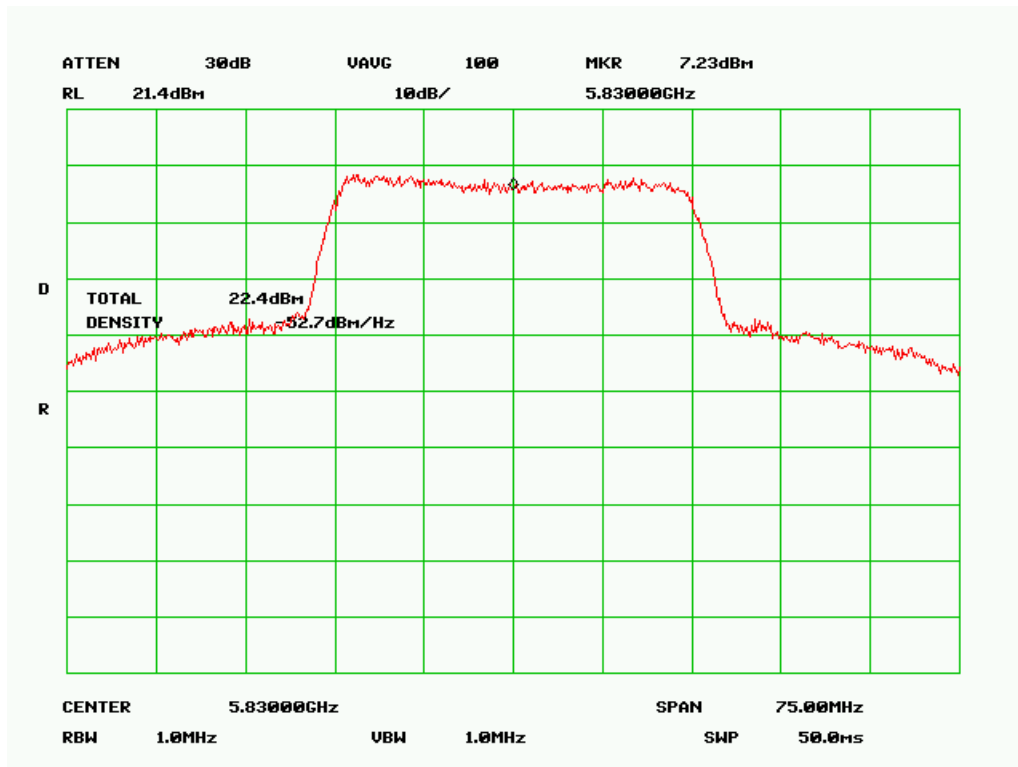

High Channel (32MHz Mode 2)

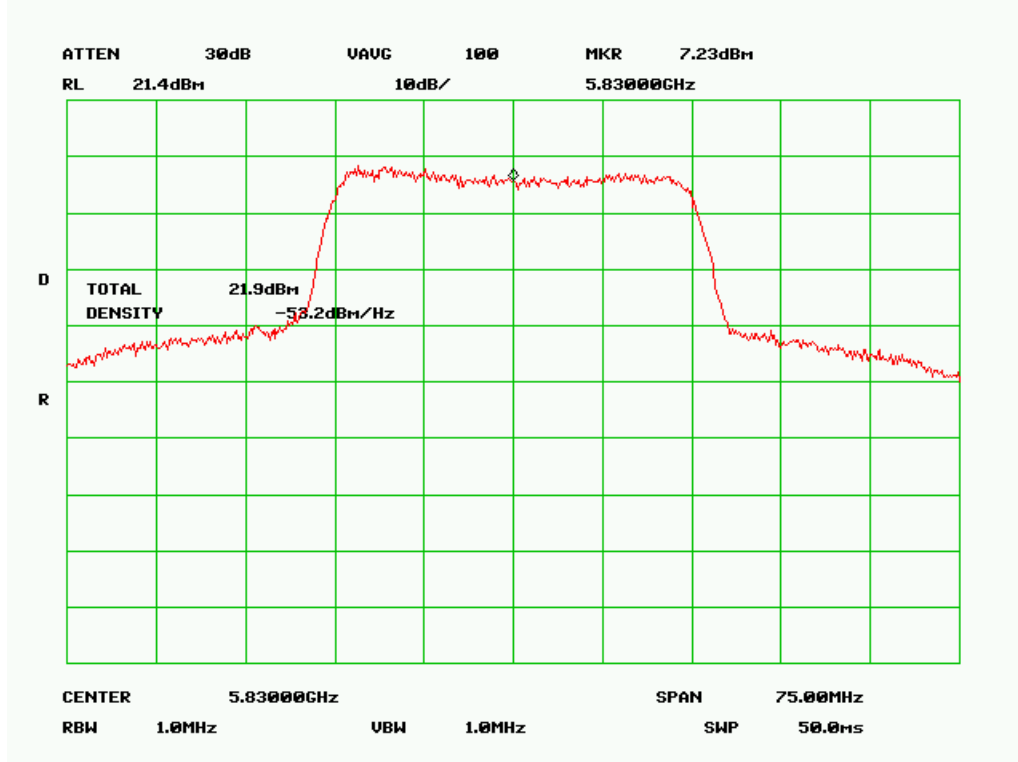

High Channel (32MHz Mode 3)

5.10 Antenna Port Emission

1. Conducted Measurement

EUT was set for low , mid, high channel with modulated mode and highest RF output power.
The spectrum analyzer was connected to the antenna terminal.

2. Conducted Emissions Measurement Uncertainty

All test measurements carried out are traceable to national standards. The uncertainty of the measurement at a confidence level of approximately 95% (in the case where distributions are normal), with a coverage factor of 2, in the range 30MHz – 40GHz is ± 1.5 dB.

3. Environmental Conditions

Temperature	23°C
Relative Humidity	50%
Atmospheric Pressure	1019mbar

4. Test Date : July 10-21 2009

Tested By :Choon Sian Ooi

Standard Requirement : 47 CFR §15.247(d); RSS210(A8.5)

Procedures: The conducted spurious emissions were measured conducted using a spectrum analyzer at low, mid, and hi channels. The limit was determined by attenuating 20 dB of the RF peak power output

Test Result:

Low Channel (8MHz Mode 1)

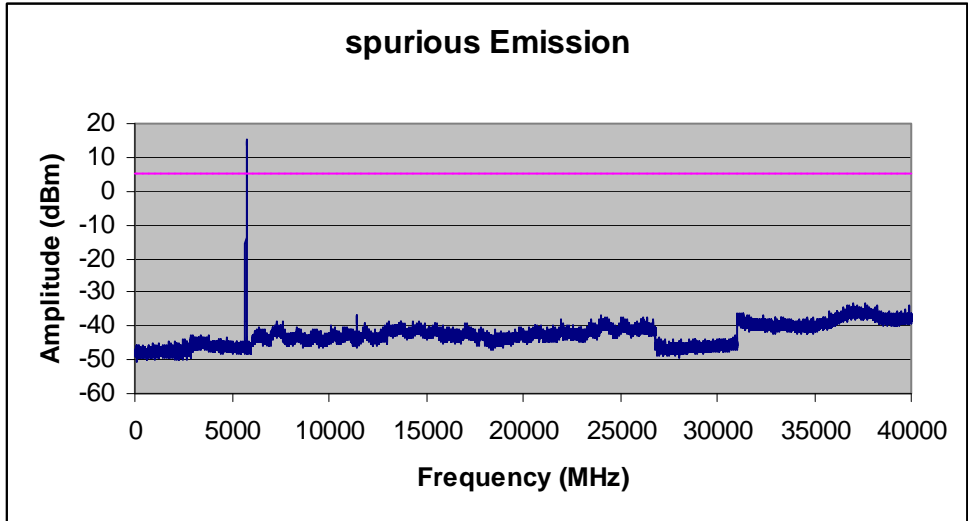

Low Channel (8MHz Mode 2)

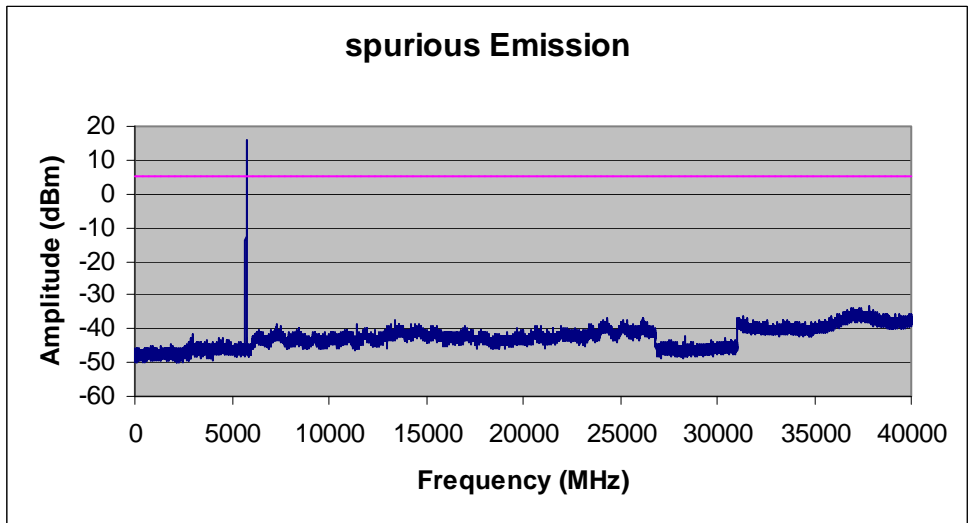



Low Channel (8MHz Mode 3)

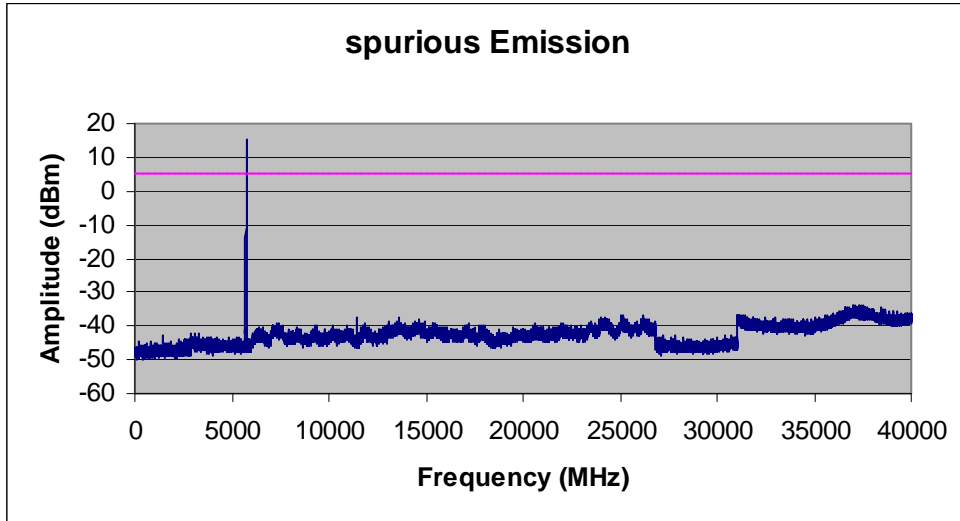

Mid Channel (8MHz Mode 1)

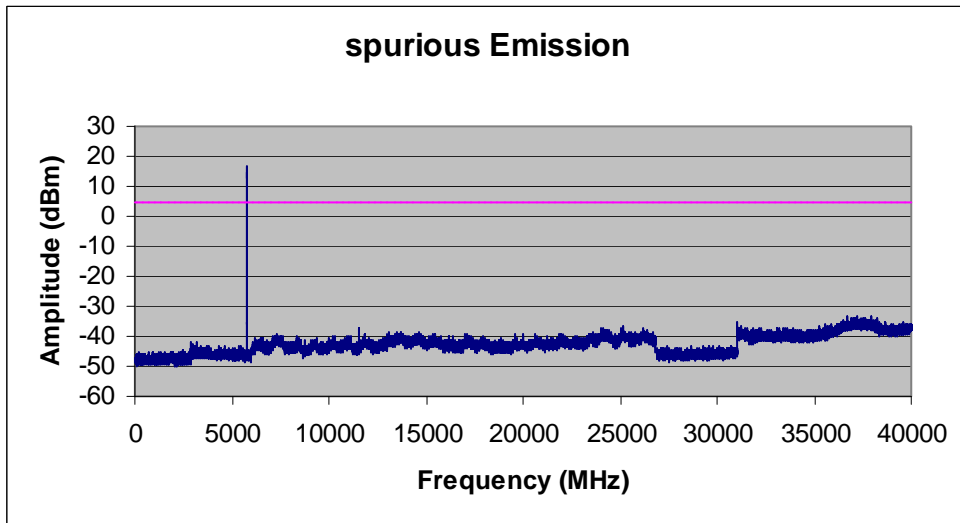

Mid Channel (8MHz Mode 2)

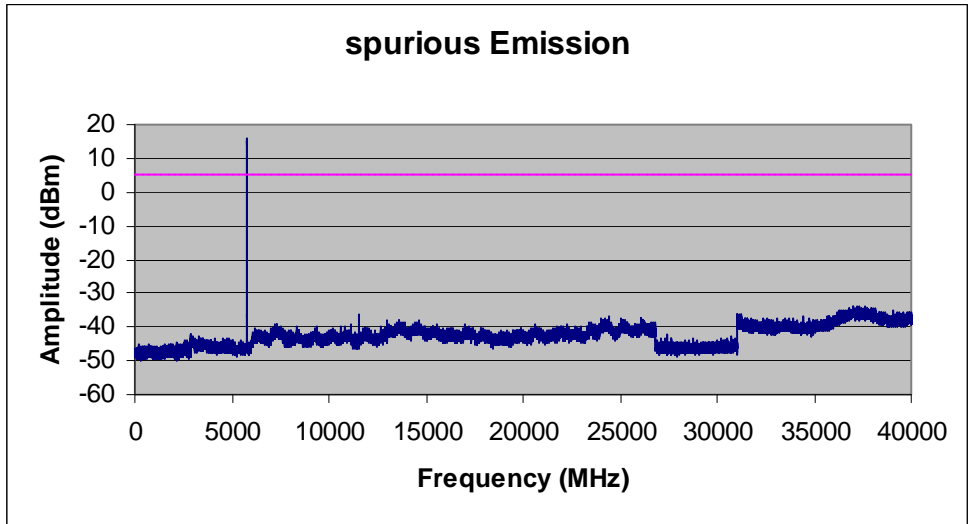

Mid Channel (8MHz Mode 3)

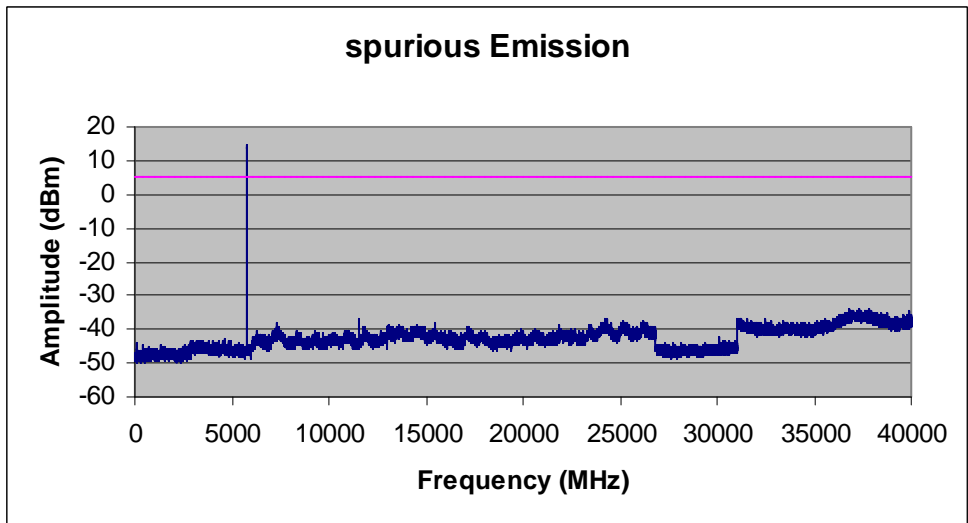



High Channel (8MHz Mode 1)

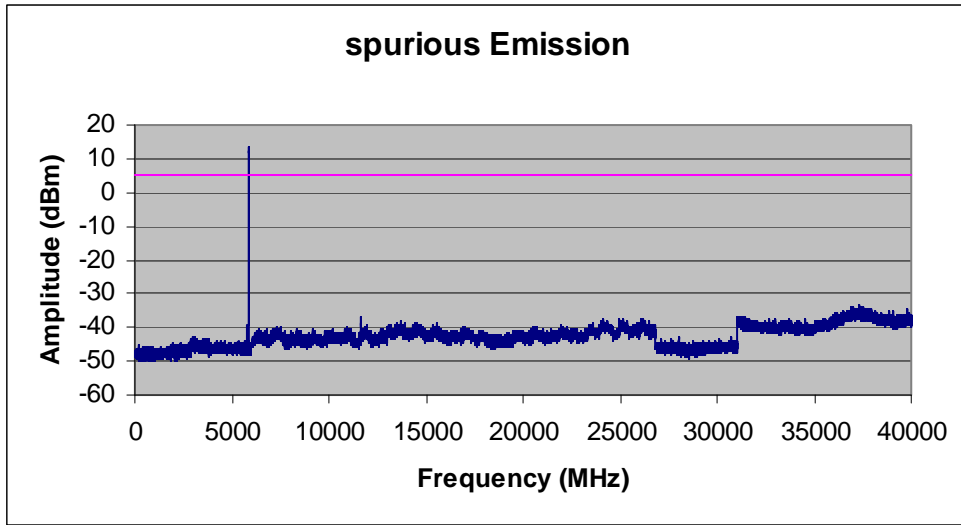

High Channel (8MHz Mode 2)

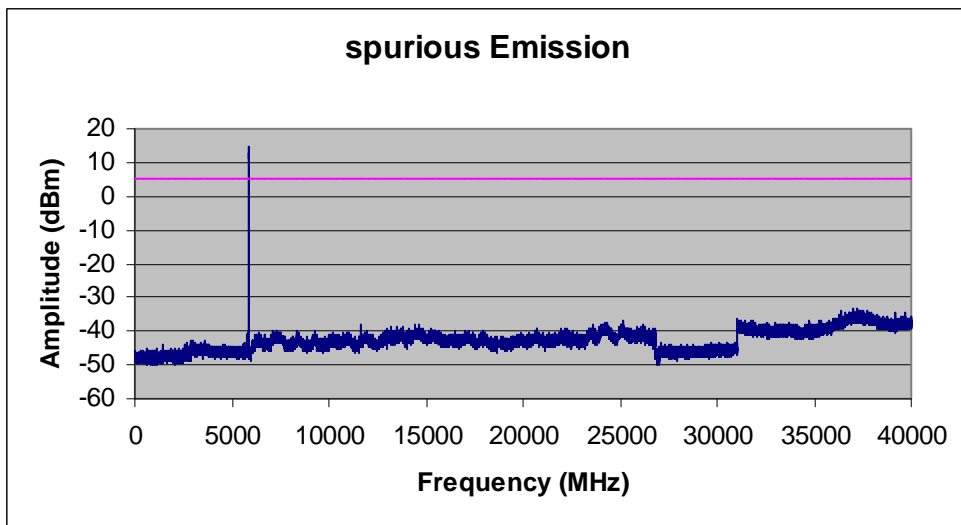

High Channel (8MHz Mode 3)

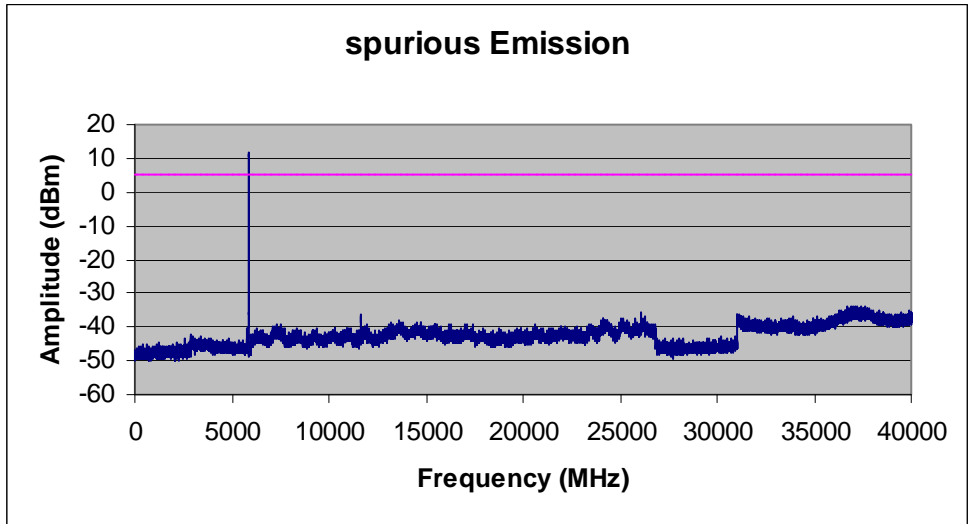

Low Channel (16MHz Mode 1)

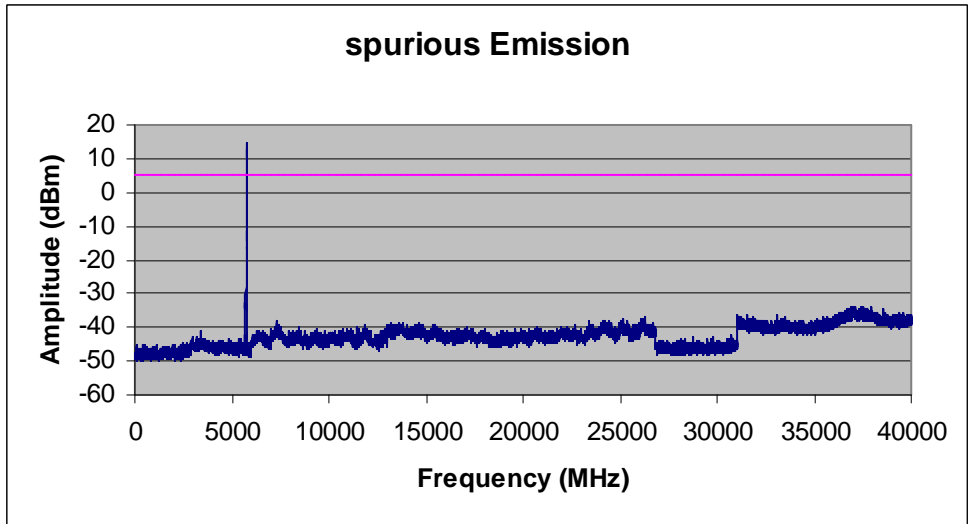

Low Channel (16MHz Mode 2)

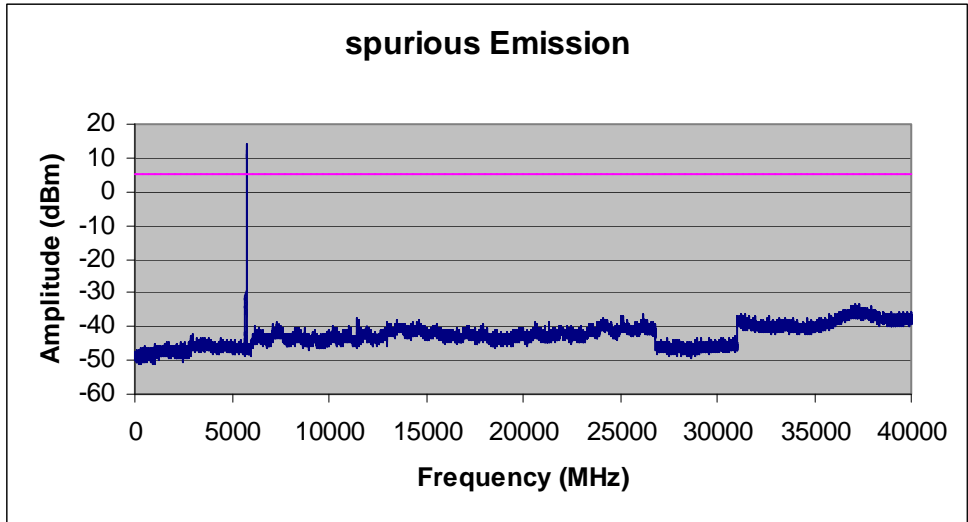

Low Channel (16MHz Mode 3)

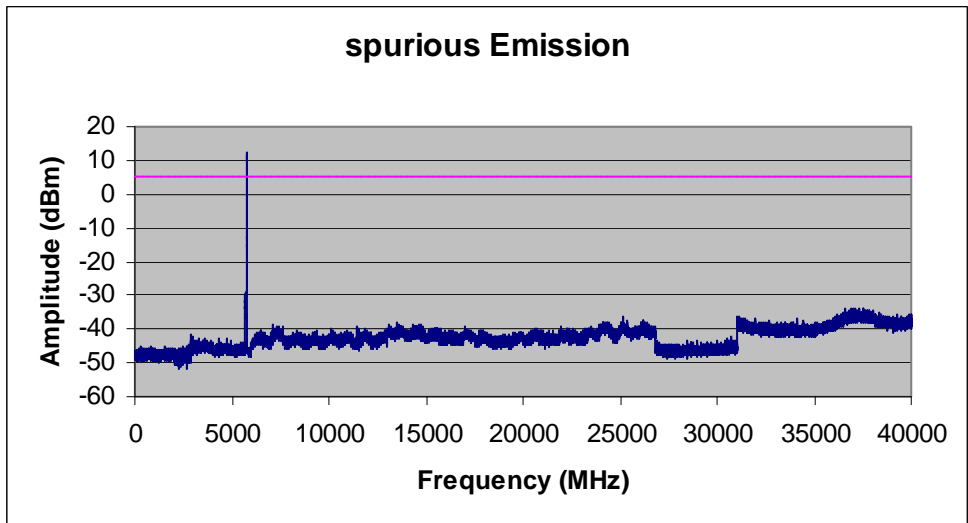

Mid Channel (16MHz Mode 1)

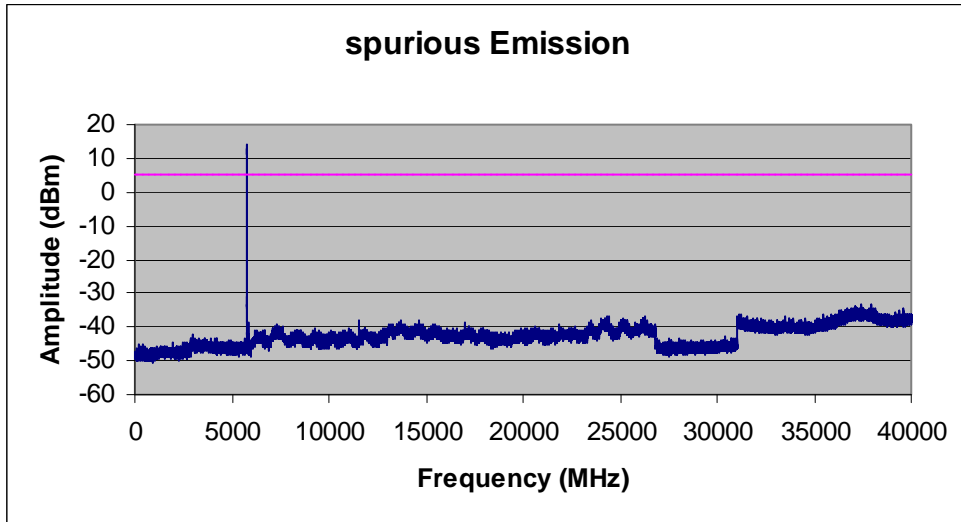

Mid Channel (16MHz Mode 2)

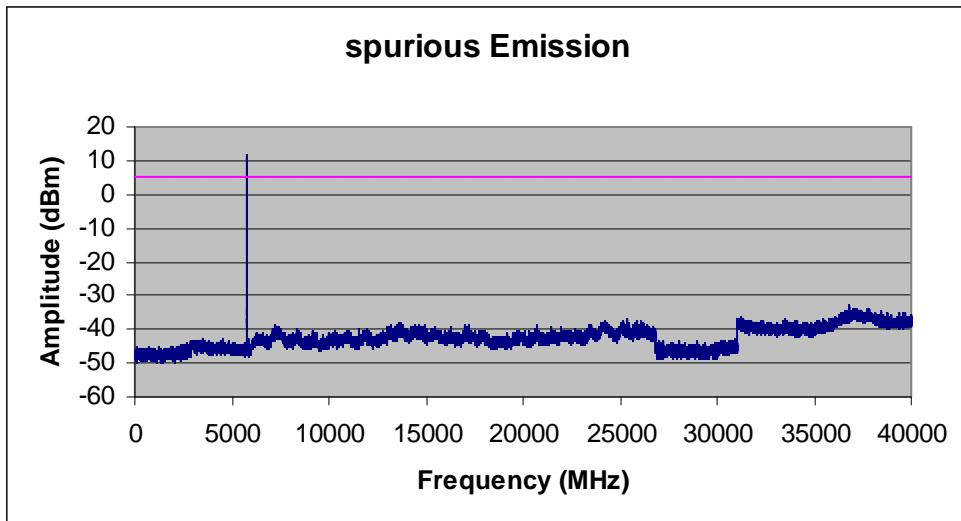

Mid Channel (16MHz Mode 3)

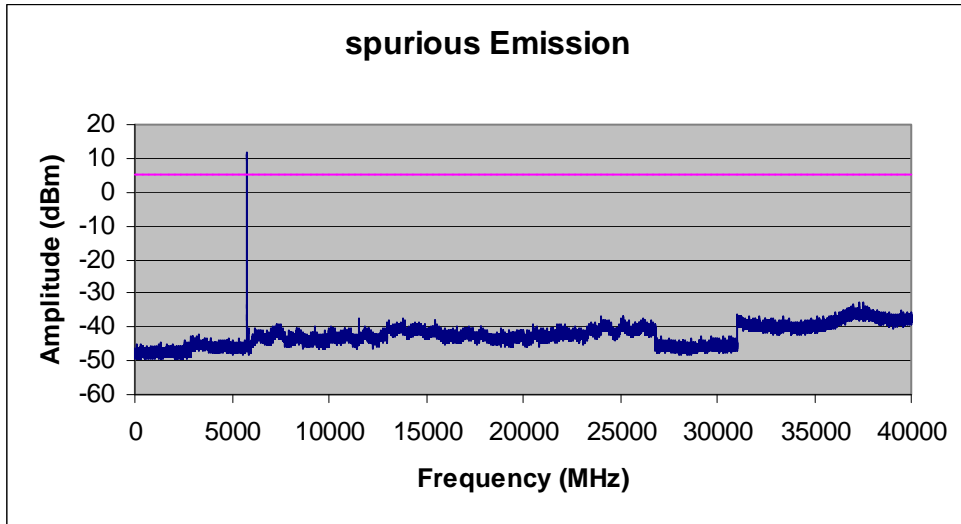

High Channel (16MHz Mode 1)

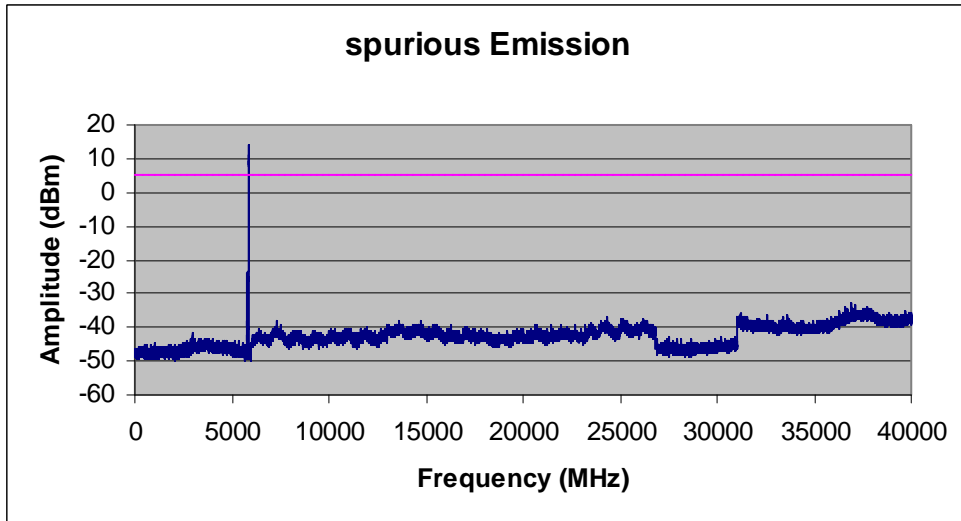

High Channel (16MHz Mode 2)

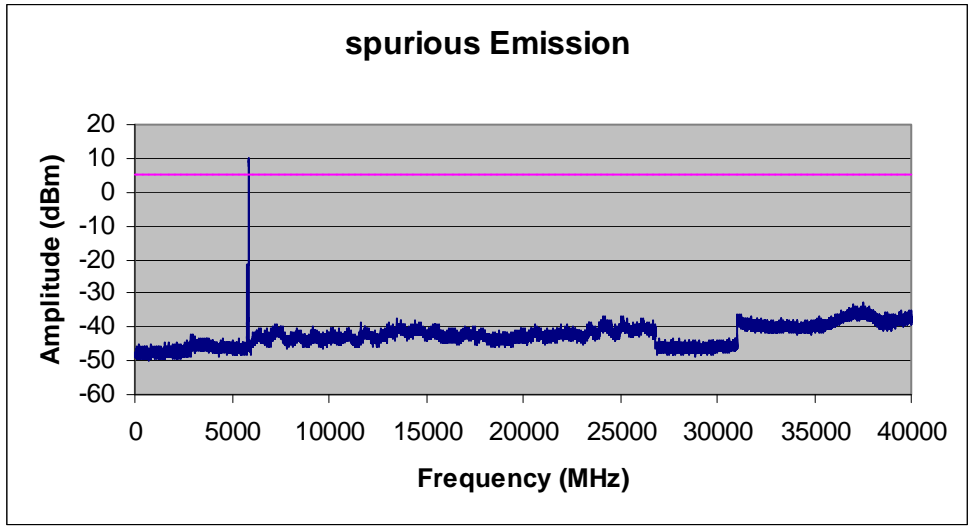

High Channel (16MHz Mode 3)

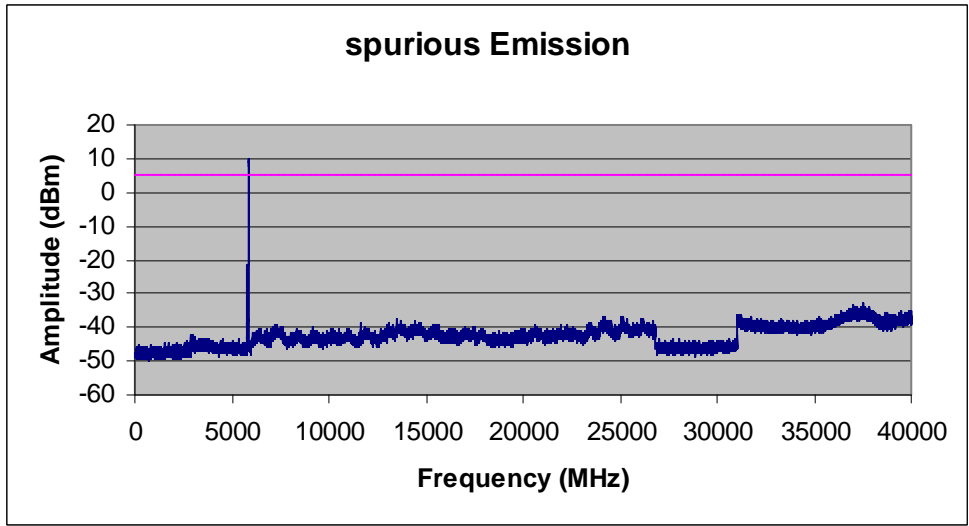

Low Channel (32MHz Mode 1)

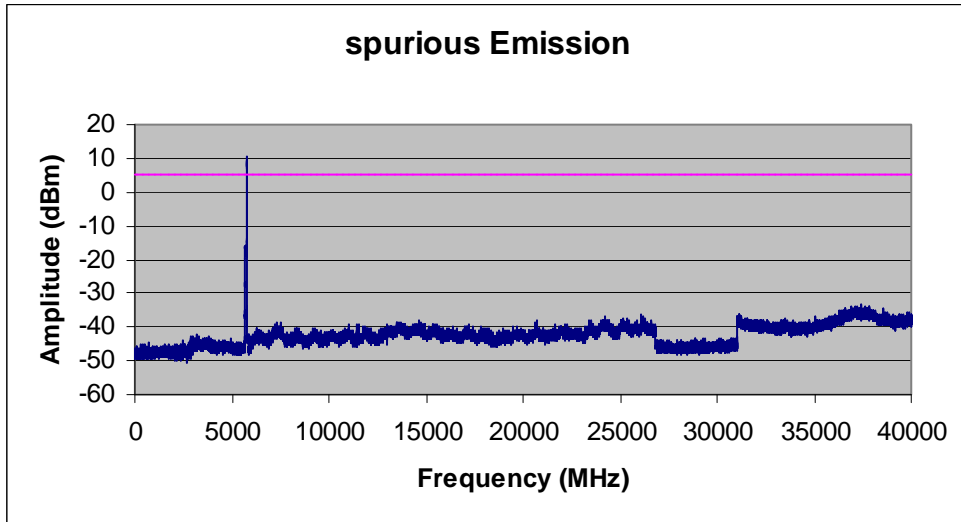

Low Channel (32MHz Mode 2)

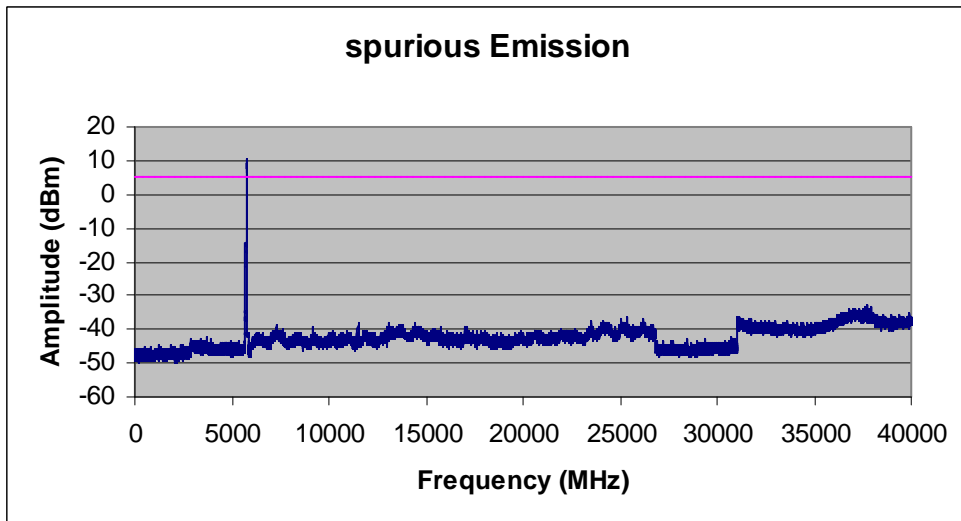

Low Channel (32MHz Mode 3)

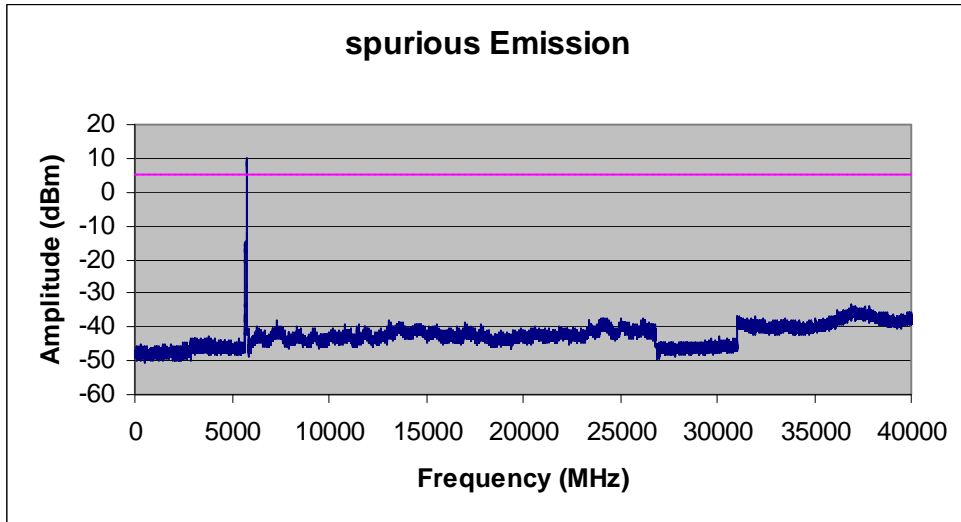

Mid Channel (32MHz Mode 1)

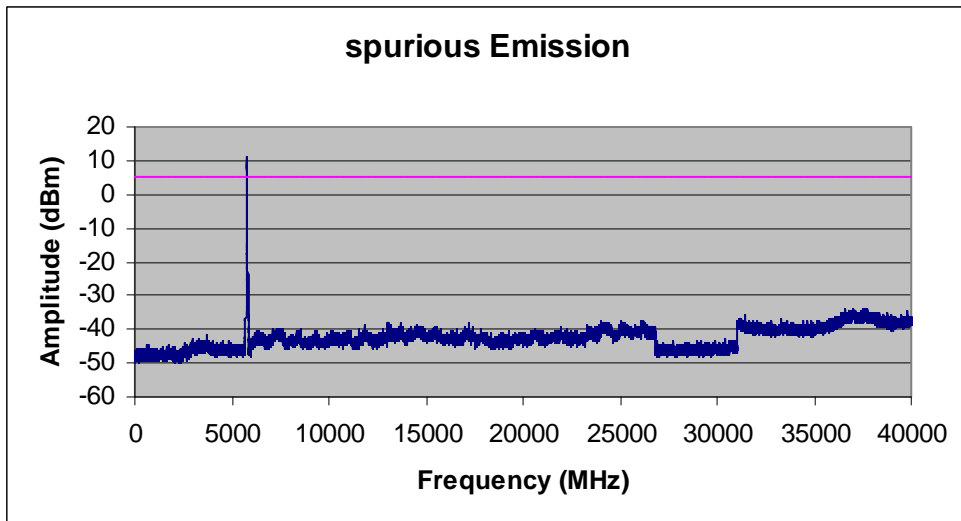

Mid Channel (32MHz Mode 2)

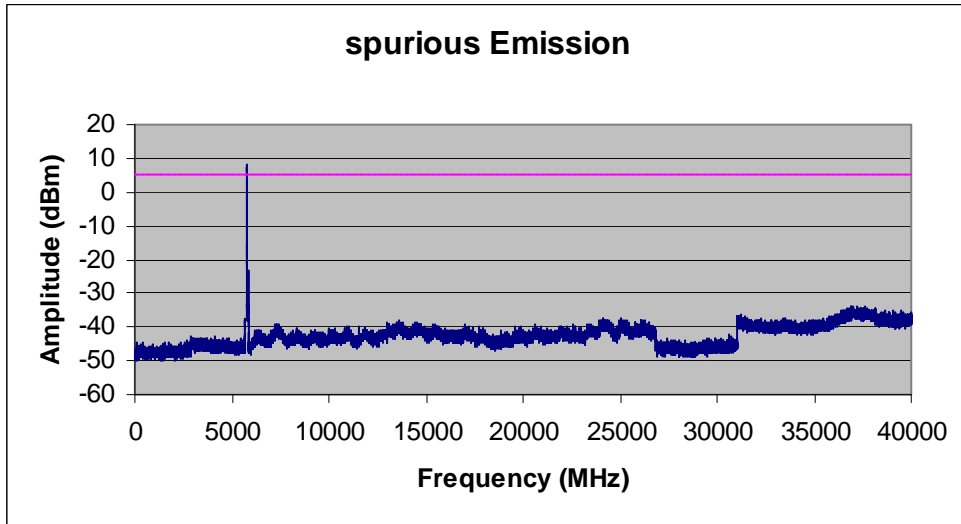

Mid Channel (32MHz Mode 3)

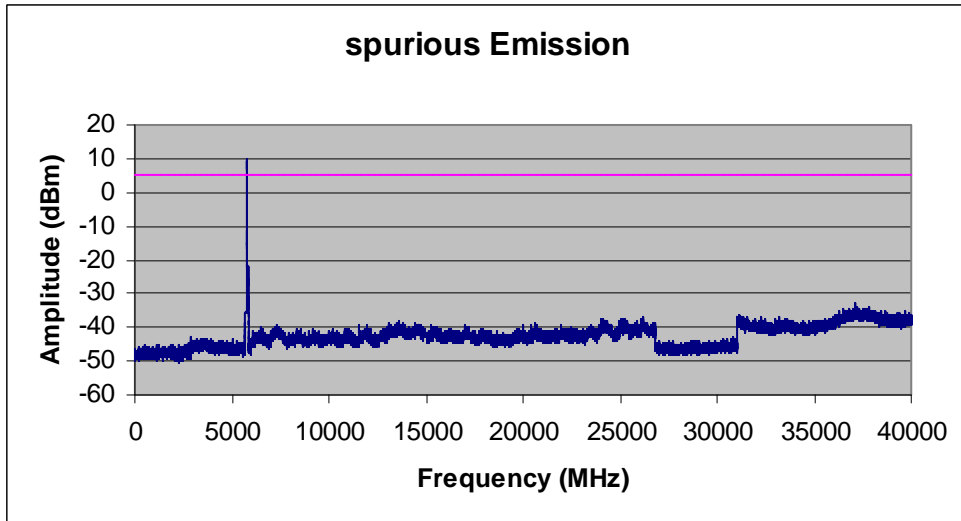

High Channel (32MHz Mode 1)

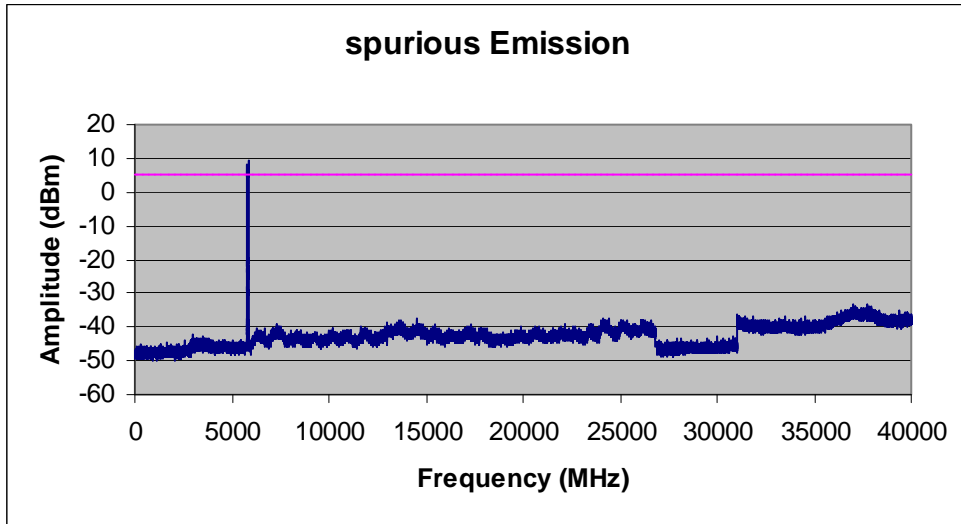

High Channel (32MHz Mode 2)

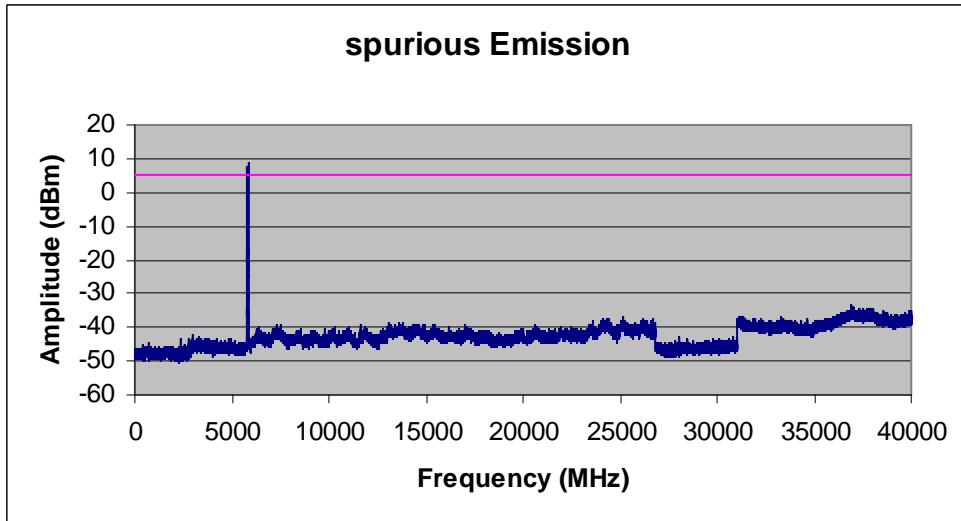

High Channel (32MHz Mode 3)

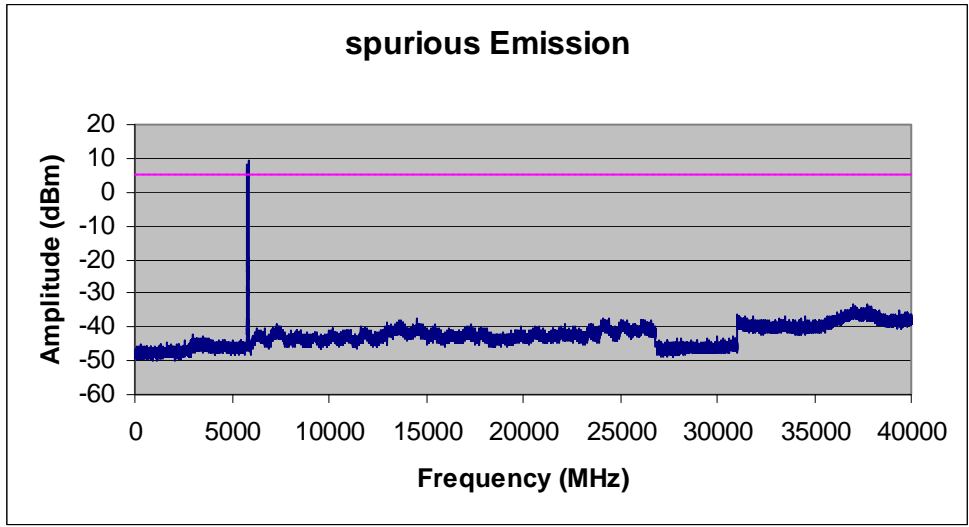

5.10 Radiated Spurious Emission < 1GHz

1. All possible modes of operation were investigated. Only the 6 worst case emissions measured, using the correct CISPR detectors, are reported. All other emissions were relatively insignificant.
2. A "-ve" margin indicates a PASS as it refers to the margin present below the limit line at the particular frequency.
3. Radiated Emissions Measurement Uncertainty
All test measurements carried out are traceable to national standards. The uncertainty of the measurement at a confidence level of approximately 95% (in the case where distributions are normal), with a coverage factor of 2, in the range 30MHz – 1GHz (QP only @ 3m & 10m) is +5.6dB/-4.5dB (for EUTs < 0.5m X 0.5m X 0.5m).
4. Environmental Conditions

Temperature	23°C
Relative Humidity	50%
Atmospheric Pressure	1019mbar

Test Date : January 12-23 2009
Tested By : Choon Sian Ooi

Standard Requirement : 47 CFR §15.247(d); RSS210(A8.5)

Procedures: Radiated emissions were measured according to ANSI C63.4. The EUT was set to transmit at the highest output power. The EUT was set to transmit at mid channel. Note that setting the channel other than mid, the spurious emissions are the same.

The limit is converted from microvolts/meter to decibel microvolts/meter.

Sample Calculation: Corrected Amplitude = Raw Amplitude(dBµV/m) + ACF(dB) + Cable Loss(dB)

Test Result:

Radiated Emission Plot (Transmit Mode)

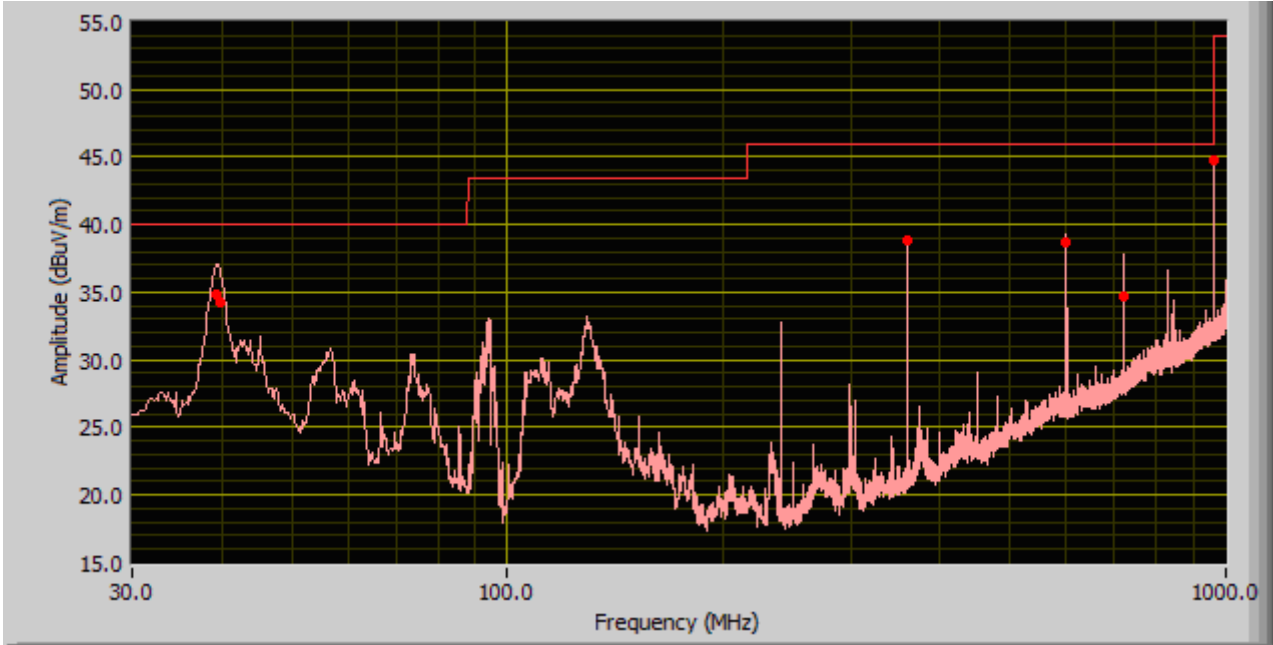

Test Data

Frequency (MHz)	Quasi-Peak (dB μ V/m)	Antenna height (cm)	Polarity	Turntable position (deg)	Limit (dB μ V/m)	Margin (dB)
959.98	44.84	108.00	V	236.00	46.00	-1.16
39.35	34.91	104.00	H	359.00	40.00	-5.09
39.66	34.19	101.00	V	37.00	40.00	-5.81
599.99	38.69	104.00	V	162.00	46.00	-7.31
359.99	38.82	100.00	V	134.00	46.00	-7.18
720.00	34.65	207.00	H	271.00	46.00	-11.35

Radiated Emission Plot (Receive Mode)

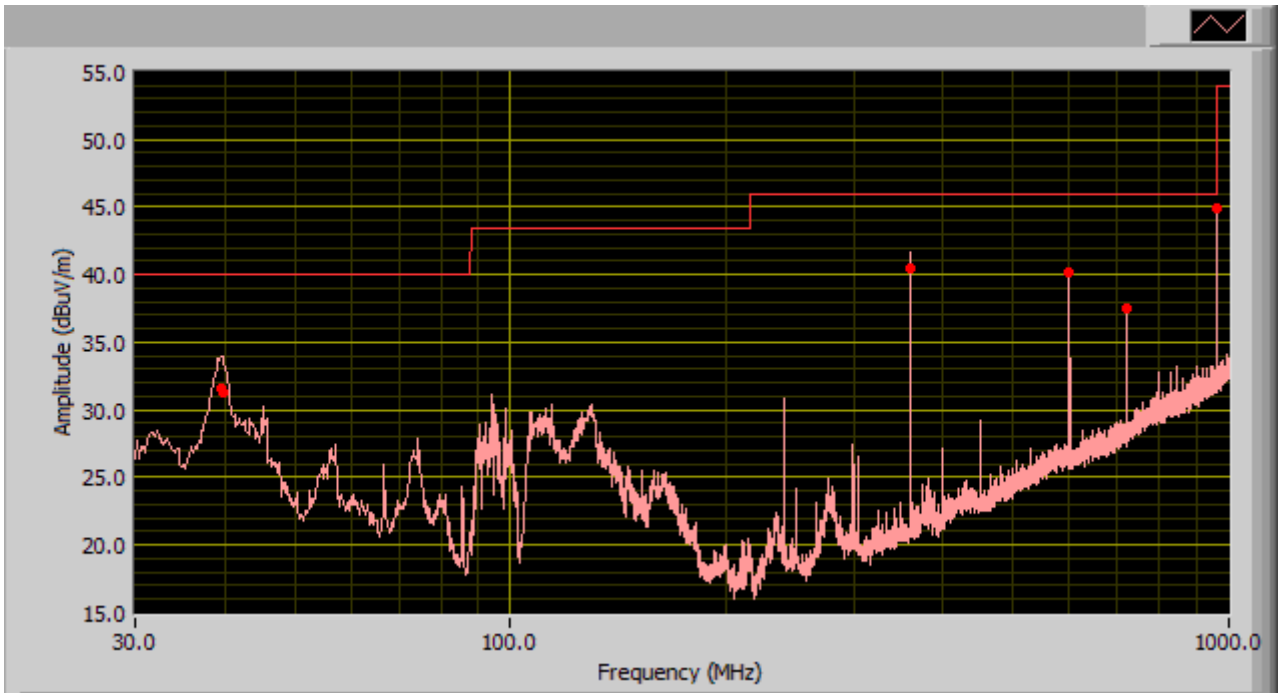

Test Data

Frequency (MHz)	Quasi-Peak (dB μ V/m)	Antenna height (cm)	Polarity	Turntable position (deg)	Limit (dB μ V/m)	Margin (dB)
959.98	44.97	108.00	V	222.00	46.00	-1.03
359.99	40.44	200.00	V	153.00	46.00	-5.56
600.01	40.21	100.00	V	146.00	46.00	-5.79
39.77	31.34	110.00	V	80.00	40.00	-8.66
39.57	31.65	103.00	H	41.00	40.00	-8.35
720.00	37.49	103.00	V	142.00	46.00	-8.51

5.10 Radiated Spurious Emissions > 1GHz & Band Edge

1. All possible modes of operation were investigated. Only the 6 worst case emissions measured, using the correct CISPR detectors, are reported. All other emissions were relatively insignificant.
2. A "-ve" margin indicates a PASS as it refers to the margin present below the limit line at the particular frequency.
3. Radiated Emissions Measurement Uncertainty
All test measurements carried out are traceable to national standards. The uncertainty of the measurement at a confidence level of approximately 95% (in the case where distributions are normal), with a coverage factor of 2, in the range 1GHz – 40GH is +5.6dB/-4.5dB (for EUTs < 0.5m X 0.5m X 0.5m).
4. Environmental Conditions

Temperature	23°C
Relative Humidity	50%
Atmospheric Pressure	1019mbar

Test Date : January 12-23 2009
 Tested By :Choon Sian Ooi

Standard Requirement: 47 CFR §15.247(d); RSS210(A8.5)

Procedures: Equipment was setup in a semi-anechoic chamber. For measurements above 1 GHz an average measurement was taken with a 10Hz video bandwidth. The EUT was tested at low, mid and high with the highest output power. Investigated up to 10th harmonic of the operating frequency.

Sample Calculation:

EUT Field Strength = Raw Amplitude(dBμV/m) – Amplifier Gain(dB) + Antenna Factor(dB) + Cable Loss(dB) + Filter Attenuation(dB, if used)

Test Result:

Low Channel (8MHz Mode 1)

Frequency	Reading	Direction	Height	Polar	Antenna Loss	Cable loss	Amplifier	Corrected Reading	15.247/15.209	15.247/15.209	
GHz	(dBuV/m)	Degree	Meter	H / V	(dB)	(dB)	(dB)	(dBuV/m)	Limit (dBuV/m)	Margin	Comments
11.46	52.78	0.00	1.50	v	42.20	7.17	32.70	69.45	74.00	-4.55	Peak
11.46	49.67	0.00	1.50	h	42.20	7.17	32.70	66.34	74.00	-7.66	Peak
11.46	36.94	0.00	1.50	v	42.20	7.17	32.70	53.61	54.00	-0.39	Ave
11.46	36.77	0.00	1.50	h	42.20	7.17	32.70	53.44	54.00	-0.56	Ave

Low Channel (8MHz Mode 2)

Frequency	Reading	Direction	Height	Polar	Antenna Loss	Cable loss	Amplifier	Corrected Reading	15.247/15.209	15.247/15.209	
GHz	(dBuV/m)	Degree	Meter	H / V	(dB)	(dB)	(dB)	(dBuV/m)	Limit (dBuV/m)	Margin	Comments
11.462	52.23	0	1.5	v	42.2	7.17	32.7	68.9	74	-5.10	Peak
11.462	50.57	0	1.5	h	42.2	7.17	32.7	67.24	74	-6.76	Peak
11.462	36.85	0	1.5	v	42.2	7.17	32.7	53.52	54	-0.48	Ave
11.462	36.69	0	1.5	h	42.2	7.17	32.7	53.36	54	-0.64	Ave

Low Channel (8MHz Mode 3)

Frequency	Reading	Direction	Height	Polar	Antenna Loss	Cable loss	Amplifier	Corrected Reading	15.247/15.209	15.247/15.209	
GHz	(dBuV/m)	Degree	Meter	H / V	(dB)	(dB)	(dB)	(dBuV/m)	Limit (dBuV/m)	Margin	Comments
11.46	53.67	0.00	1.50	v	42.20	7.17	32.70	70.34	74.00	-3.66	Peak
11.46	56.23	0.00	1.50	h	42.20	7.17	32.70	72.90	74.00	-1.10	Peak
11.46	36.34	0.00	1.50	v	42.20	7.17	32.70	53.01	54.00	-0.99	Ave
11.46	36.65	0.00	1.50	h	42.20	7.17	32.70	53.32	54.00	-0.68	Ave

Mid Channel (8MHz Mode 1)

Frequency	Reading	Direction	Height	Polar	Antenna Loss	Cable loss	Amplifier	Corrected Reading	15.247/15.209	15.247/15.209	
GHz	(dBuV/m)	Degree	Meter	H / V	(dB)	(dB)	(dB)	(dBuV/m)	Limit (dBuV/m)	Margin	Comments
11.57	54.96	0.00	1.50	v	43.20	7.42	32.51	73.07	74.00	-0.94	Peak
11.57	54.14	0.00	1.50	h	43.20	7.42	32.51	72.25	74.00	-1.76	Peak
11.57	35.67	0.00	1.50	v	43.20	7.42	32.51	53.78	54.00	-0.22	Ave
11.57	35.74	0.00	1.50	h	43.20	7.42	32.51	53.85	54.00	-0.15	Ave

Mid Channel (8MHz Mode 2)

Frequency	Reading	Direction	Height	Polar	Antenna Loss	Cable loss	Amplifier	Corrected Reading	15.247/15.209	15.247/15.209	
GHz	(dBuV/m)	Degree	Meter	H / V	(dB)	(dB)	(dB)	(dBuV/m)	Limit (dBuV/m)	Margin	Comments
11.57	54.94	0.00	1.50	v	43.20	7.42	32.51	73.05	74.00	-0.95	Peak
11.57	54.73	0.00	1.50	h	43.20	7.42	32.51	72.84	74.00	-1.16	Peak
11.57	35.37	0.00	1.50	v	43.20	7.42	32.51	53.48	54.00	-0.52	Ave
11.57	35.17	0.00	1.50	h	43.20	7.42	32.51	53.28	54.00	-0.72	Ave

Mid Channel (8MHz Mode 3)

Frequency	Reading	Direction	Height	Polar	Antenna Loss	Cable loss	Amplifier	Corrected Reading	15.247/15.209	15.247/15.209	
GHz	(dBuV/m)	Degree	Meter	H / V	(dB)	(dB)	(dB)	(dBuV/m)	Limit (dBuV/m)	Margin	Comments
11.57	54.54	0.00	1.50	v	43.20	7.42	32.51	72.65	74.00	-1.35	Peak
11.57	54.23	0.00	1.50	h	43.20	7.42	32.51	72.34	74.00	-1.66	Peak
11.57	35.75	0.00	1.50	v	43.20	7.42	32.51	53.86	54.00	-0.14	Ave
11.57	35.64	0.00	1.50	h	43.20	7.42	32.51	53.75	54.00	-0.25	Ave

High Channel (8MHz Mode 1)

Frequency	Reading	Direction	Height	Polar	Antenna Loss	Cable loss	Amplifier	Corrected Reading	15.247/15.209	15.247/15.209	
GHz	(dBuV/m)	Degree	Meter	H / V	(dB)	(dB)	(dB)	(dBuV/m)	Limit (dBuV/m)	Margin	Comments
11.57	54.54	0.00	1.50	v	43.20	7.42	32.51	72.65	74.00	-1.35	Peak
11.57	54.23	0.00	1.50	h	43.20	7.42	32.51	72.34	74.00	-1.66	Peak
11.57	35.75	0.00	1.50	v	43.20	7.42	32.51	53.86	54.00	-0.14	Ave
11.57	35.64	0.00	1.50	h	43.20	7.42	32.51	53.75	54.00	-0.25	Ave

High Channel (8MHz Mode 2)

Frequency	Reading	Direction	Height	Polar	Antenna Loss	Cable loss	Amplifier	Corrected Reading	15.247/15.209	15.247/15.209	
GHz	(dBuV/m)	Degree	Meter	H / V	(dB)	(dB)	(dB)	(dBuV/m)	Limit (dBuV/m)	Margin	Comments
11.57	54.54	0.00	1.50	v	43.20	7.42	32.51	72.65	74.00	-1.35	Peak
11.57	54.23	0.00	1.50	h	43.20	7.42	32.51	72.34	74.00	-1.66	Peak
11.57	35.75	0.00	1.50	v	43.20	7.42	32.51	53.86	54.00	-0.14	Ave
11.57	35.64	0.00	1.50	h	43.20	7.42	32.51	53.75	54.00	-0.25	Ave

High Channel (8MHz Mode 3)

Frequency	Reading	Direction	Height	Polar	Antenna Loss	Cable loss	Amplifier	Corrected Reading	15.247/15.209	15.247/15.209	
GHz	(dBuV/m)	Degree	Meter	H / V	(dB)	(dB)	(dB)	(dBuV/m)	Limit (dBuV/m)	Margin	Comments
11.69	55.52	0.00	1.50	v	43.20	7.42	32.51	73.63	74.00	-0.38	Peak
11.69	55.22	0.00	1.50	h	43.20	7.42	32.51	73.33	74.00	-0.67	Peak
11.69	35.83	0.00	1.50	v	43.20	7.42	32.51	53.94	54.00	-0.06	Ave
11.69	35.62	0.00	1.50	h	43.20	7.42	32.51	53.73	54.00	-0.27	Ave

Low Channel (16MHz Mode 1)

Frequency	Reading	Direction	Height	Polar	Antenna Loss	Cable loss	Amplifier	Corrected Reading	15.247/15.209	15.247/15.209	
GHz	(dBuV/m)	Degree	Meter	H / V	(dB)	(dB)	(dB)	(dBuV/m)	Limit (dBuV/m)	Margin	Comments
11.47	56.52	0.00	1.50	v	42.20	7.17	32.70	73.19	74.00	-0.81	Peak
11.47	56.28	0.00	1.50	h	42.20	7.17	32.70	72.95	74.00	-1.05	Peak
11.47	35.77	0.00	1.50	v	42.20	7.17	32.70	52.44	54.00	-1.56	Ave
11.47	35.62	0.00	1.50	h	42.20	7.17	32.70	52.29	54.00	-1.71	Ave

Low Channel (16MHz Mode 2)

Frequency	Reading	Direction	Height	Polar	Antenna Loss	Cable loss	Amplifier	Corrected Reading	15.247/15.209	15.247/15.209	
GHz	(dBuV/m)	Degree	Meter	H / V	(dB)	(dB)	(dB)	(dBuV/m)	Limit (dBuV/m)	Margin	Comments
11.47	56.82	0.00	1.50	v	42.20	7.17	32.70	73.49	74.00	-0.51	Peak
11.47	56.29	0.00	1.50	h	42.20	7.17	32.70	72.96	74.00	-1.04	Peak
11.47	37.15	0.00	1.50	v	42.20	7.17	32.70	53.82	54.00	-0.18	Ave
11.47	36.96	0.00	1.50	h	42.20	7.17	32.70	53.63	54.00	-0.37	Ave

Low Channel (16MHz Mode 3)

Frequency	Reading	Direction	Height	Polar	Antenna Loss	Cable loss	Amplifier	Corrected Reading	15.247/15.209	15.247/15.209	
GHz	(dBuV/m)	Degree	Meter	H / V	(dB)	(dB)	(dB)	(dBuV/m)	Limit (dBuV/m)	Margin	Comments
11.47	56.47	v160	1.00	v	42.20	7.17	32.70	73.14	74.00	-0.86	Peak
11.47	56.27	178.00	1.30	h	42.20	7.17	32.70	72.94	74.00	-1.06	Peak
11.47	37.32	160.00	1.00	v	42.20	7.17	32.70	53.99	54.00	-0.01	Ave
11.47	36.21	178.00	1.30	h	42.20	7.17	32.70	52.88	54.00	-1.12	Ave

Mid Channel (16MHz Mode 1)

Frequency	Reading	Direction	Height	Polar	Antenna Loss	Cable loss	Amplifier	Corrected Reading	15.247/15.209	15.247/15.209	
GHz	(dBuV/m)	Degree	Meter	H / V	(dB)	(dB)	(dB)	(dBuV/m)	Limit (dBuV/m)	Margin	Comments
11.58	55.86	0.00	1.50	v	43.20	7.42	32.51	73.97	74.00	-0.03	Peak
11.58	55.69	0.00	1.50	h	43.20	7.42	32.51	73.80	74.00	-0.20	Peak
11.58	35.74	0.00	1.50	v	43.20	7.42	32.51	53.85	54.00	-0.15	Ave
11.58	35.36	0.00	1.50	h	43.20	7.42	32.51	53.47	54.00	-0.53	Ave

Mid Channel (16MHz Mode 2)

Frequency	Reading	Direction	Height	Polar	Antenna Loss	Cable loss	Amplifier	Corrected Reading	15.247/15.209	15.247/15.209	
GHz	(dBuV/m)	Degree	Meter	H / V	(dB)	(dB)	(dB)	(dBuV/m)	Limit (dBuV/m)	Margin	Comments
11.58	55.54	0.00	1.50	v	43.20	7.42	32.51	73.65	74.00	-0.35	Peak
11.58	55.51	0.00	1.50	h	43.20	7.42	32.51	73.62	74.00	-0.38	Peak
11.58	35.86	0.00	1.50	v	43.20	7.42	32.51	53.97	54.00	-0.03	Ave
11.58	35.77	0.00	1.50	h	43.20	7.42	32.51	53.88	54.00	-0.12	Ave

Mid Channel (16MHz Mode 3)

Frequency	Reading	Direction	Height	Polar	Antenna Loss	Cable loss	Amplifier	Corrected Reading	15.247/15.209	15.247/15.209	
GHz	(dBuV/m)	Degree	Meter	H / V	(dB)	(dB)	(dB)	(dBuV/m)	Limit (dBuV/m)	Margin	Comments
11.58	55.68	0.00	1.50	v	43.20	7.42	32.51	73.79	74.00	-0.22	Peak
11.58	55.62	0.00	1.50	h	43.20	7.42	32.51	73.73	74.00	-0.28	Peak
11.58	35.64	0.00	1.50	v	43.20	7.42	32.51	53.75	54.00	-0.25	Ave
11.58	35.56	0.00	1.50	h	43.20	7.42	32.51	53.67	54.00	-0.33	Ave

High Channel (16MHz Mode 1)

Frequency	Reading	Direction	Height	Polar	Antenna Loss	Cable loss	Amplifier	Corrected Reading	15.247/15.209	15.247/15.209	
GHz	(dBuV/m)	Degree	Meter	H / V	(dB)	(dB)	(dB)	(dBuV/m)	Limit (dBuV/m)	Margin	Comments
11.68	54.95	0.00	1.50	v	43.20	7.42	32.51	73.06	74.00	-0.94	Peak
11.68	54.75	0.00	1.50	h	43.20	7.42	32.51	72.86	74.00	-1.14	Peak
11.68	35.36	0.00	1.50	v	43.20	7.42	32.51	53.47	54.00	-0.53	Ave
11.68	35.17	0.00	1.50	h	43.20	7.42	32.51	53.28	54.00	-0.72	Ave

High Channel (16MHz Mode 2)

Frequency	Reading	Direction	Height	Polar	Antenna Loss	Cable loss	Amplifier	Corrected Reading	15.247/15.209	15.247/15.209	
GHz	(dBuV/m)	Degree	Meter	H / V	(dB)	(dB)	(dB)	(dBuV/m)	Limit (dBuV/m)	Margin	Comments
11.68	55.58	0.00	1.50	v	43.20	7.42	32.51	73.69	74.00	-0.31	Peak
11.68	55.36	0.00	1.50	h	43.20	7.42	32.51	73.47	74.00	-0.53	Peak
11.68	35.41	0.00	1.50	v	43.20	7.42	32.51	53.52	54.00	-0.48	Ave
11.68	35.27	0.00	1.50	h	43.20	7.42	32.51	53.38	54.00	-0.62	Ave

High Channel (16MHz Mode 3)

Frequency	Reading	Direction	Height	Polar	Antenna Loss	Cable loss	Amplifier	Corrected Reading	15.247/15.209	15.247/15.209	
GHz	(dBuV/m)	Degree	Meter	H / V	(dB)	(dB)	(dB)	(dBuV/m)	Limit (dBuV/m)	Margin	Comments
11.68	55.24	0.00	1.50	v	43.20	7.42	32.51	73.35	74.00	-0.66	Peak
11.68	55.19	0.00	1.50	h	43.20	7.42	32.51	73.30	74.00	-0.70	Peak
11.68	35.17	0.00	1.50	v	43.20	7.42	32.51	53.28	54.00	-0.72	Ave
11.68	35.04	0.00	1.50	h	43.20	7.42	32.51	53.15	54.00	-0.85	Ave

Low Channel (32MHz Mode 1)

Frequency	Reading	Direction	Height	Polar	Antenna Loss	Cable loss	Amplifier	Corrected Reading	15.247/15.209	15.247/15.209	
GHz	(dBuV/m)	Degree	Meter	H / V	(dB)	(dB)	(dB)	(dBuV/m)	Limit (dBuV/m)	Margin	Comments
11.49	57.16	0.00	1.50	v	42.20	7.17	32.70	73.83	74.00	-0.17	Peak
11.49	56.74	0.00	1.50	h	42.20	7.17	32.70	73.41	74.00	-0.59	Peak
11.49	37.17	0.00	1.50	v	42.20	7.17	32.70	53.84	54.00	-0.16	Ave
11.49	36.95	0.00	1.50	h	42.20	7.17	32.70	53.62	54.00	-0.38	Ave

Low Channel (32MHz Mode 2)

Frequency	Reading	Direction	Height	Polar	Antenna Loss	Cable loss	Amplifier	Corrected Reading	15.247/15.209	15.247/15.209	
GHz	(dBuV/m)	Degree	Meter	H / V	(dB)	(dB)	(dB)	(dBuV/m)	Limit (dBuV/m)	Margin	Comments
11.49	56.94	0.00	1.50	v	42.20	7.17	32.70	73.61	74.00	-0.39	Peak
11.49	56.59	0.00	1.50	h	42.20	7.17	32.70	73.26	74.00	-0.74	Peak
11.49	36.64	0.00	1.50	v	42.20	7.17	32.70	53.31	54.00	-0.69	Ave
11.49	36.34	0.00	1.50	h	42.20	7.17	32.70	53.01	54.00	-0.99	Ave

Low Channel (32MHz Mode 3)

Frequency	Reading	Direction	Height	Polar	Antenna Loss	Cable loss	Amplifier	Corrected Reading	15.247/15.209	15.247/15.209	
GHz	(dBuV/m)	Degree	Meter	H / V	(dB)	(dB)	(dB)	(dBuV/m)	Limit (dBuV/m)	Margin	Comments
11.49	57.44	0.00	1.50	v	42.20	7.17	32.70	74.11	74.00	0.11	Peak
11.49	57.13	0.00	1.50	h	42.20	7.17	32.70	73.80	74.00	-0.20	Peak
11.49	36.74	0.00	1.50	v	42.20	7.17	32.70	53.41	54.00	-0.59	Ave
11.49	36.57	0.00	1.50	h	42.20	7.17	32.70	53.24	54.00	-0.76	Ave

Mid Channel (32MHz Mode 1)

Frequency	Reading	Direction	Height	Polar	Antenna Loss	Cable loss	Amplifier	Corrected Reading	15.247/15.209	15.247/15.209	
GHz	(dBuV/m)	Degree	Meter	H / V	(dB)	(dB)	(dB)	(dBuV/m)	Limit (dBuV/m)	Margin	Comments
11.58	55.36	0.00	1.50	v	43.20	7.42	32.51	73.47	74.00	-0.53	Peak
11.58	55.13	0.00	1.50	h	43.20	7.42	32.51	73.24	74.00	-0.76	Peak
11.58	35.34	0.00	1.50	v	43.20	7.42	32.51	53.45	54.00	-0.55	Ave
11.58	35.25	0.00	1.50	h	43.20	7.42	32.51	53.36	54.00	-0.64	Ave

Mid Channel (32MHz Mode 2)

Frequency	Reading	Direction	Height	Polar	Antenna Loss	Cable loss	Amplifier	Corrected Reading	15.247/15.209	15.247/15.209	
GHz	(dBuV/m)	Degree	Meter	H / V	(dB)	(dB)	(dB)	(dBuV/m)	Limit (dBuV/m)	Margin	Comments
11.58	55.16	0.00	1.50	v	43.20	7.42	32.51	73.27	74.00	-0.73	Peak
11.58	55.02	0.00	1.50	h	43.20	7.42	32.51	73.13	74.00	-0.88	Peak
11.58	35.42	0.00	1.50	v	43.20	7.42	32.51	53.53	54.00	-0.47	Ave
11.58	35.39	0.00	1.50	h	43.20	7.42	32.51	53.50	54.00	-0.50	Ave

Mid Channel (32MHz Mode 3)

Frequency	Reading	Direction	Height	Polar	Antenna Loss	Cable loss	Amplifier	Corrected Reading	15.247/15.209	15.247/15.209	
GHz	(dBuV/m)	Degree	Meter	H / V	(dB)	(dB)	(dB)	(dBuV/m)	Limit (dBuV/m)	Margin	Comments
11.58	55.46	0.00	1.50	v	43.20	7.42	32.51	73.57	74.00	-0.44	Peak
11.58	55.24	0.00	1.50	h	43.20	7.42	32.51	73.35	74.00	-0.66	Peak
11.58	35.12	0.00	1.50	v	43.20	7.42	32.51	53.23	54.00	-0.77	Ave
11.58	35.29	0.00	1.50	h	43.20	7.42	32.51	53.40	54.00	-0.60	Ave

High Channel (32MHz Mode 1)

Frequency	Reading	Direction	Height	Polar	Antenna Loss	Cable loss	Amplifier	Corrected Reading	15.247/15.209	15.247/15.209	
GHz	(dBuV/m)	Degree	Meter	H / V	(dB)	(dB)	(dB)	(dBuV/m)	Limit (dBuV/m)	Margin	Comments
11.66	55.36	0.00	1.50	v	43.20	7.42	32.51	73.47	74.00	-0.53	Peak
11.66	55.14	0.00	1.50	h	43.20	7.42	32.51	73.25	74.00	-0.75	Peak
11.66	35.32	0.00	1.50	v	43.20	7.42	32.51	53.43	54.00	-0.57	Ave
11.66	35.21	0.00	1.50	h	43.20	7.42	32.51	53.32	54.00	-0.68	Ave

High Channel (32MHz Mode 2)

Frequency	Reading	Direction	Height	Polar	Antenna Loss	Cable loss	Amplifier	Corrected Reading	15.247/15.209	15.247/15.209	
GHz	(dBuV/m)	Degree	Meter	H / V	(dB)	(dB)	(dB)	(dBuV/m)	Limit (dBuV/m)	Margin	Comments
11.66	55.31	0.00	1.50	v	43.20	7.42	32.51	73.42	74.00	-0.58	Peak
11.66	55.29	0.00	1.50	h	43.20	7.42	32.51	73.40	74.00	-0.60	Peak
11.66	35.12	0.00	1.50	v	43.20	7.42	32.51	53.23	54.00	-0.77	Ave
11.66	35.04	0.00	1.50	h	43.20	7.42	32.51	53.15	54.00	-0.85	Ave

High Channel (32MHz Mode 3)

Frequency	Reading	Direction	Height	Polar	Antenna Loss	Cable loss	Amplifier	Corrected Reading	15.247/15.209	15.247/15.209	
GHz	(dBuV/m)	Degree	Meter	H / V	(dB)	(dB)	(dB)	(dBuV/m)	Limit (dBuV/m)	Margin	Comments
11.66	55.41	0.00	1.50	v	43.20	7.42	32.51	73.52	74.00	-0.48	Peak
11.66	55.36	0.00	1.50	h	43.20	7.42	32.51	73.47	74.00	-0.53	Peak
11.66	35.34	0.00	1.50	v	43.20	7.42	32.51	53.45	54.00	-0.55	Ave
11.66	35.19	0.00	1.50	h	43.20	7.42	32.51	53.30	54.00	-0.70	Ave

Vertical Polarity

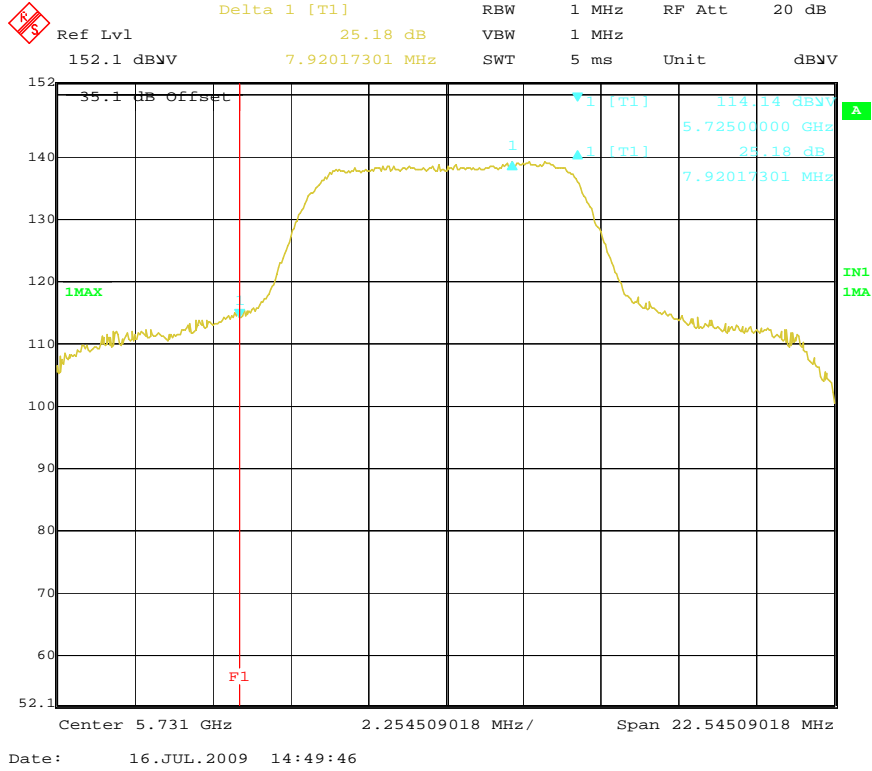

Low Channel (8MHz Mode 1)

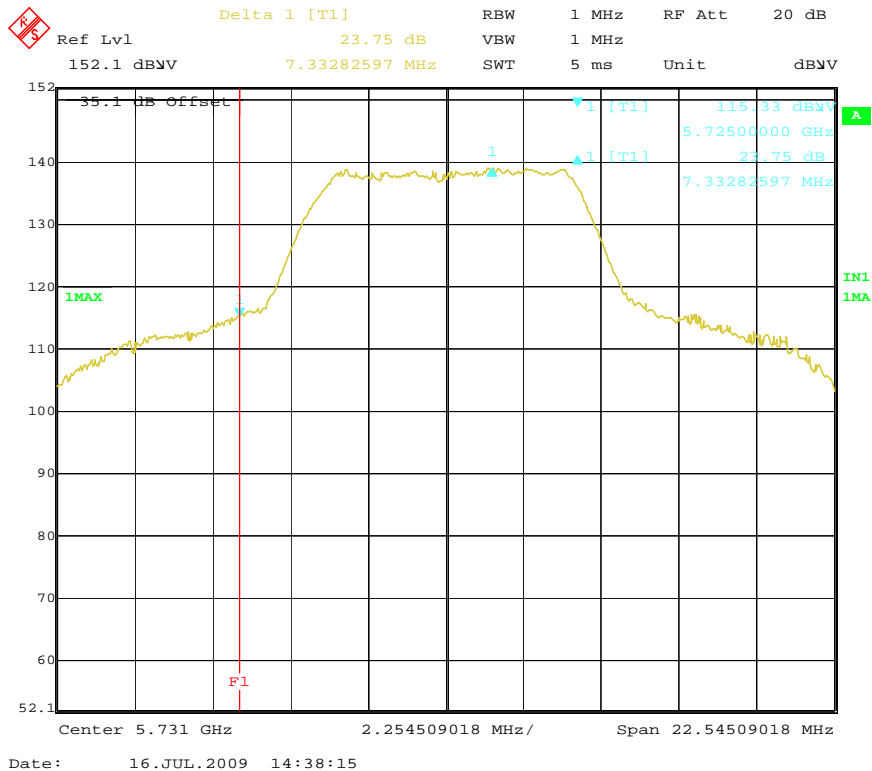

Low Channel (8MHz Mode 2)

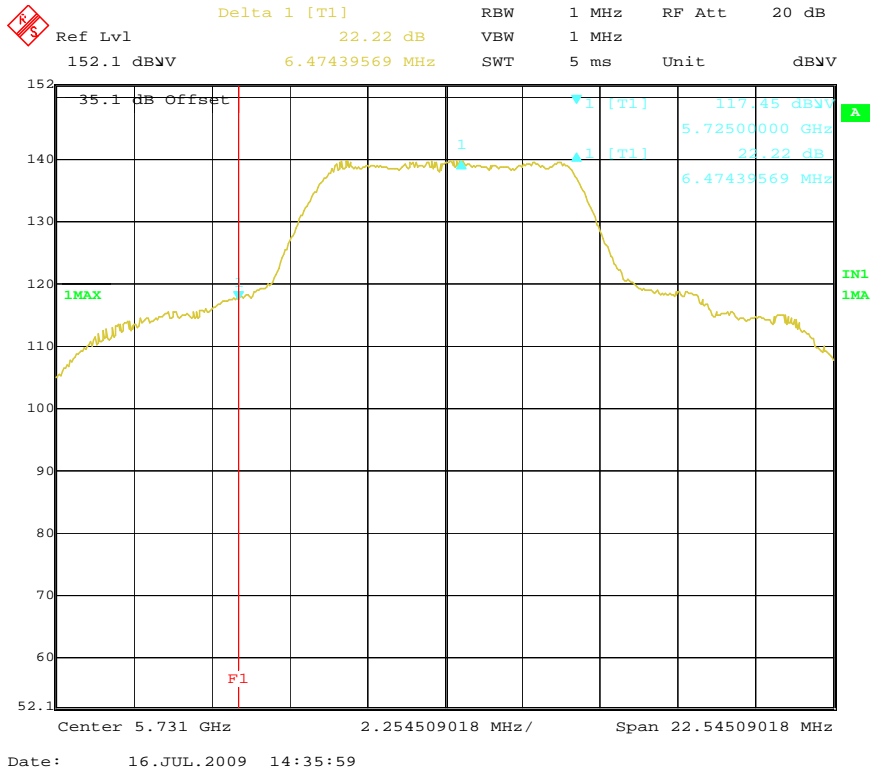

Low Channel (8MHz Mode 3)

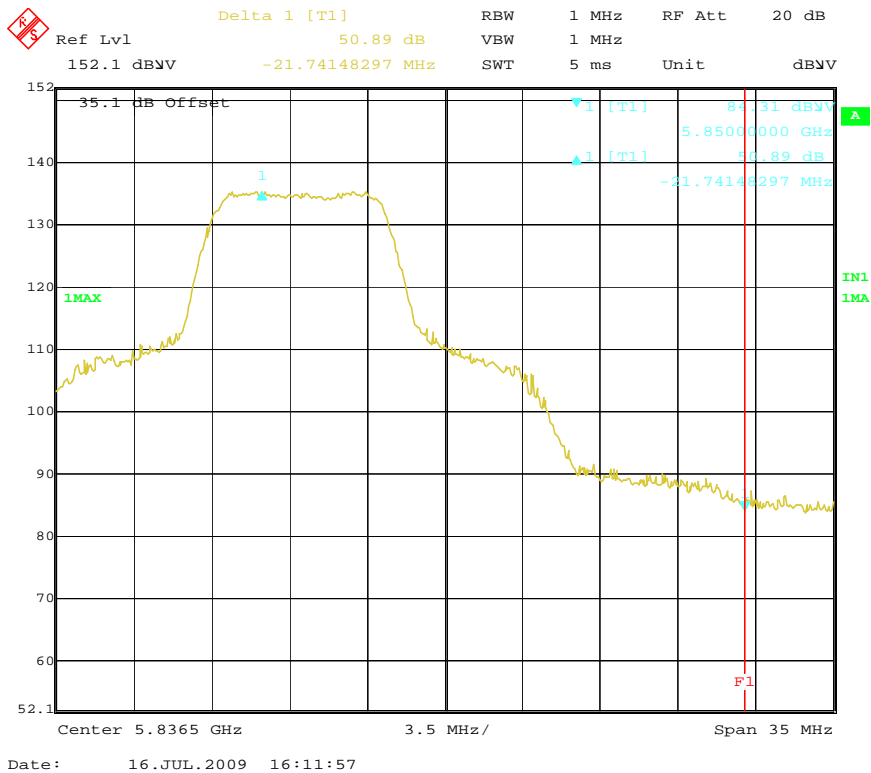

High Channel (8MHz Mode 1)



Delta 1 [T1] RBW 1 MHz RF Att 20 dB
Ref Lvl 47.35 dB VBW 1 MHz
152.1 dBV -23.07414830 MHz SWT 5 ms Unit dBV

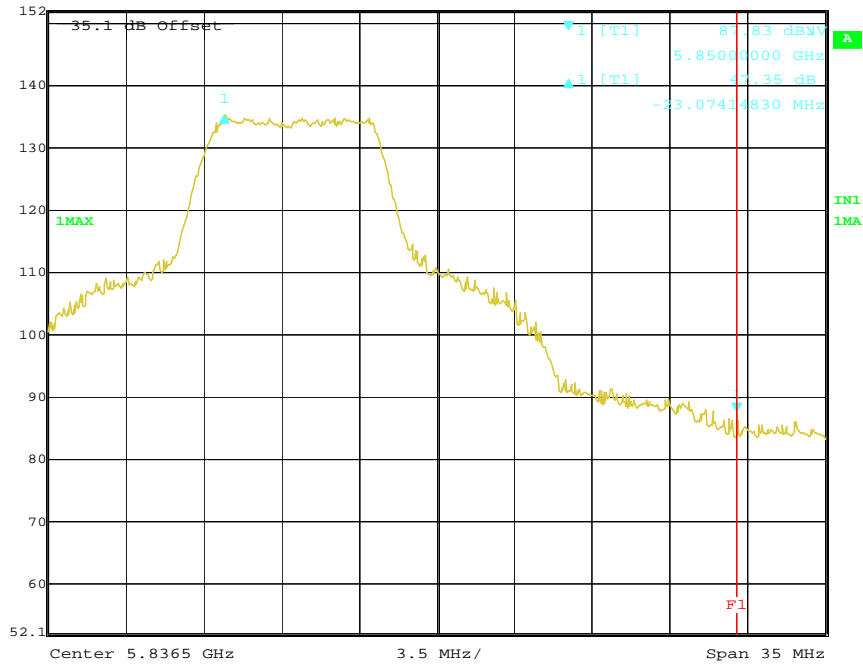

Date: 16.JUL.2009 16:13:26

High Channel (8MHz Mode 2)

Delta 1 [T1] RBW 1 MHz RF Att 20 dB
Ref Lvl 48.43 dB VBW 1 MHz
152.1 dBV -22.93386774 MHz SWT 5 ms Unit dBV

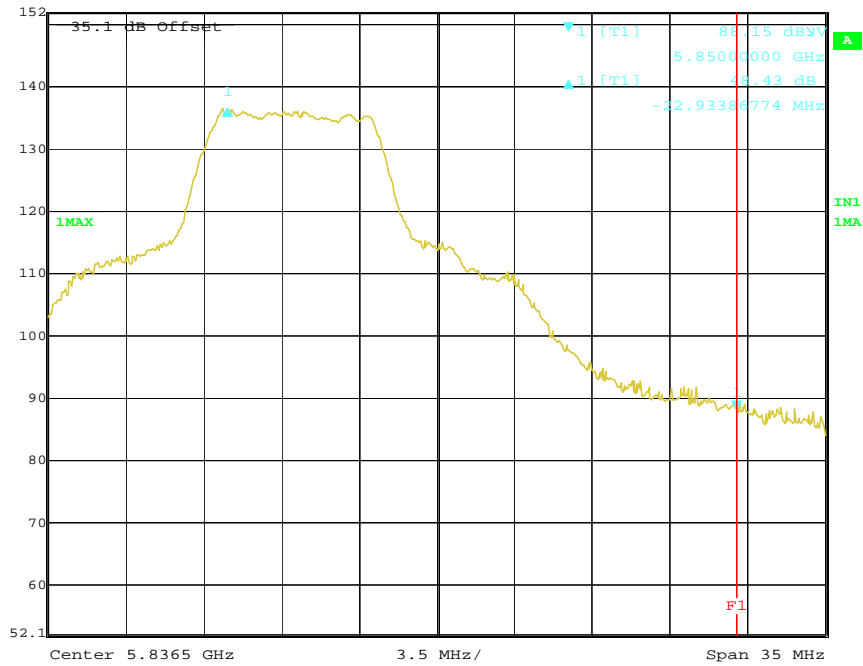

Date: 16.JUL.2009 16:14:52

High Channel (8MHz Mode 3)



FS Delta 1 [T1] RBW 1 MHz RF Att 20 dB
Ref Lvl 26.96 dB VBW 1 MHz
152.1 dBmV 15.64428858 MHz SWT 5 ms Unit dBmV

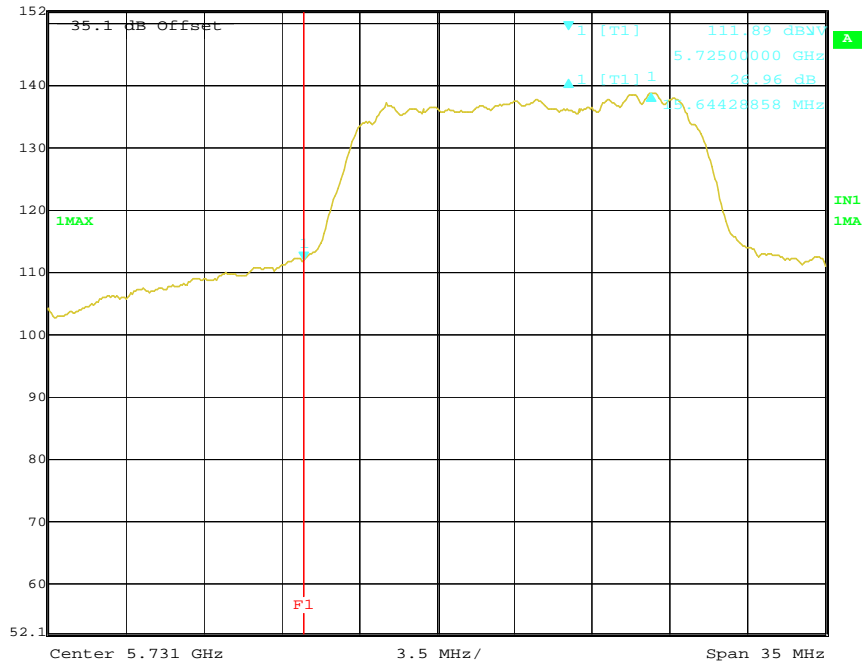

Date: 16.JUL.2009 14:54:02

Low Channel (16MHz Mode 1)

FS Delta 1 [T1] RBW 1 MHz RF Att 20 dB
Ref Lvl 28.05 dB VBW 1 MHz
152.1 dBmV 16.62625251 MHz SWT 5 ms Unit dBmV

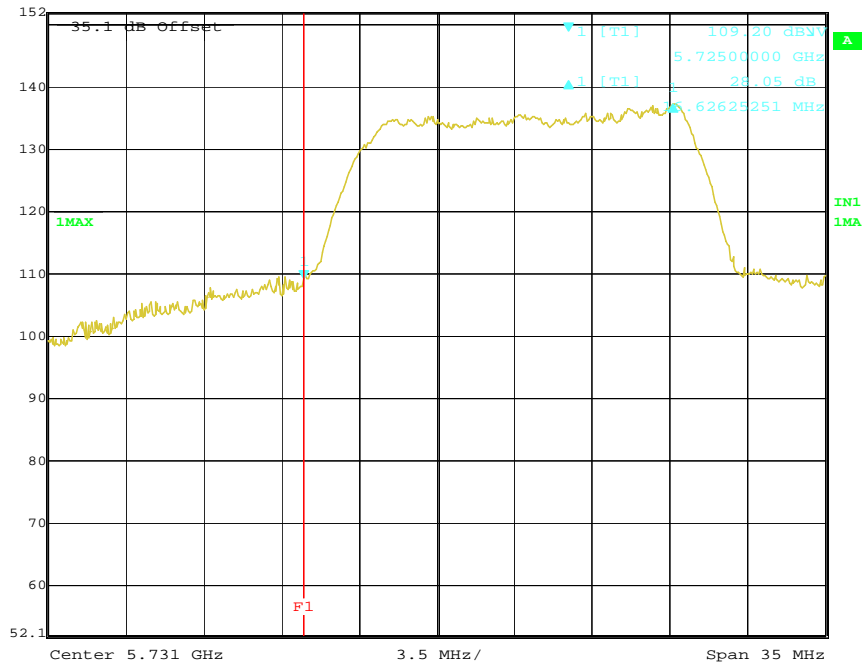

Date: 16.JUL.2009 14:55:06

Low Channel (16MHz Mode 2)



RS Delta 1 [T1] RBW 1 MHz RF Att 20 dB
Ref Lvl 27.08 dB VBW 1 MHz
152.1 dBmV 16.76653307 MHz SWT 5 ms Unit dBmV

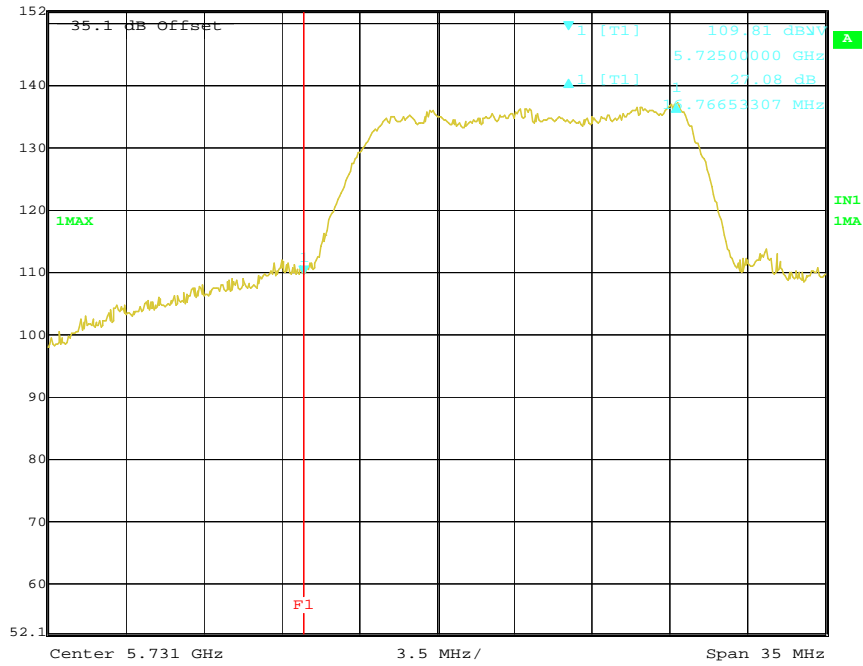

Date: 16.JUL.2009 14:55:53

Low Channel (16MHz Mode 3)

RS Delta 1 [T1] RBW 1 MHz RF Att 20 dB
Ref Lvl 41.10 dB VBW 1 MHz
152.1 dBmV -14.23647295 MHz SWT 5 ms Unit dBmV

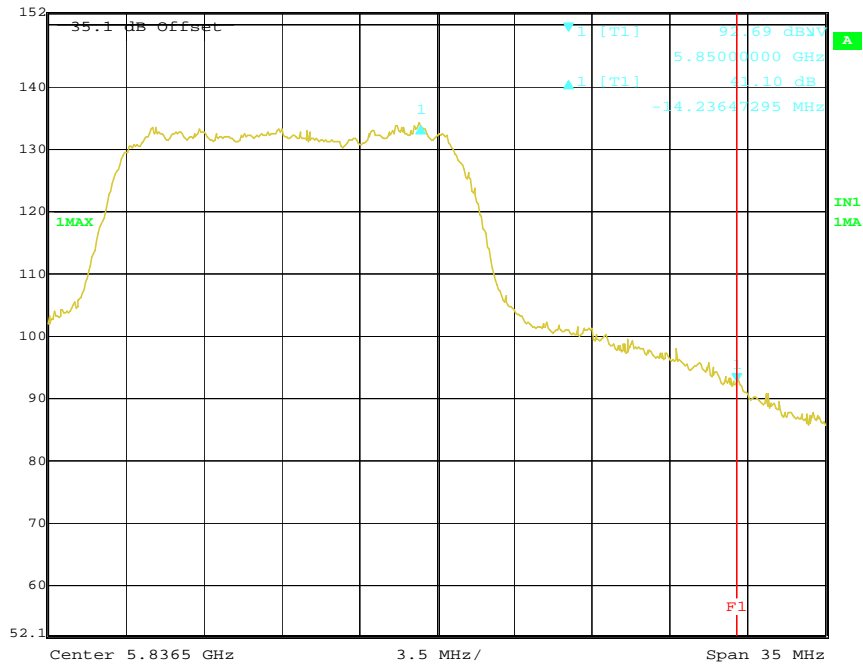

Date: 16.JUL.2009 16:04:07

High Channel (16MHz Mode 1)



FS Delta 1 [T1] RBW 1 MHz RF Att 20 dB
Ref Lvl 40.32 dB VBW 1 MHz
152.1 dBmV -13.32464930 MHz SWT 5 ms Unit dBmV

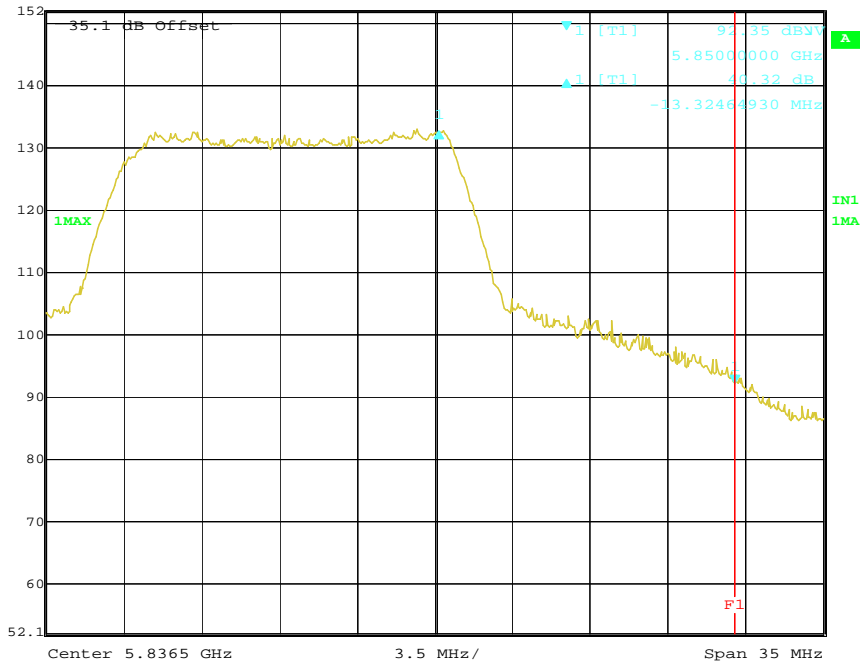

Date: 16.JUL.2009 16:09:30

High Channel (16MHz Mode 2)

FS Delta 1 [T1] RBW 1 MHz RF Att 20 dB
Ref Lvl 39.34 dB VBW 1 MHz
152.1 dBmV -20.26853707 MHz SWT 5 ms Unit dBmV

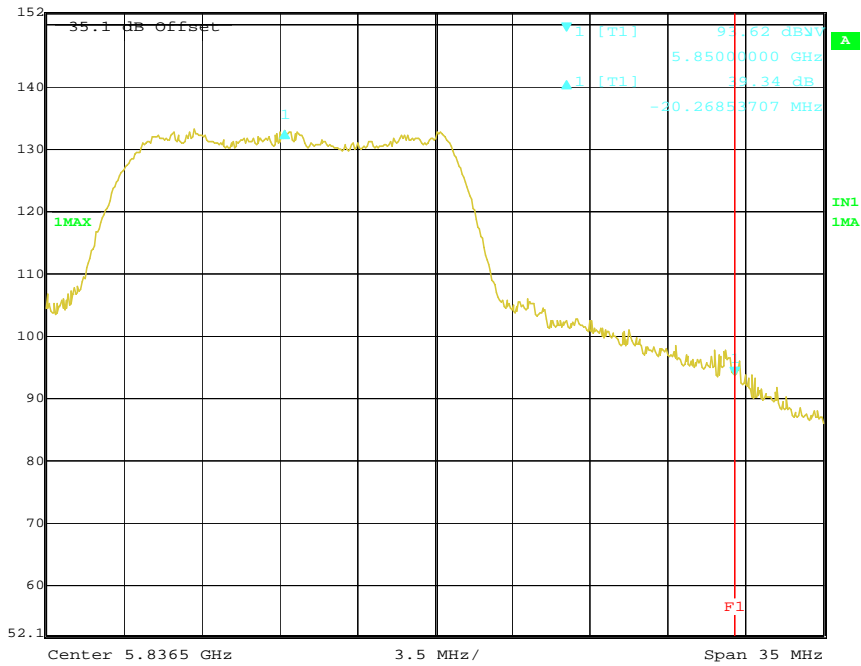

Date: 16.JUL.2009 16:08:34

High Channel (16MHz Mode 3)



Delta 1 [T1] RBW 1 MHz RF Att 20 dB
Ref Lvl 26.98 dB VBW 1 MHz
152.1 dBV 27.28136273 MHz SWT 5 ms Unit dBV

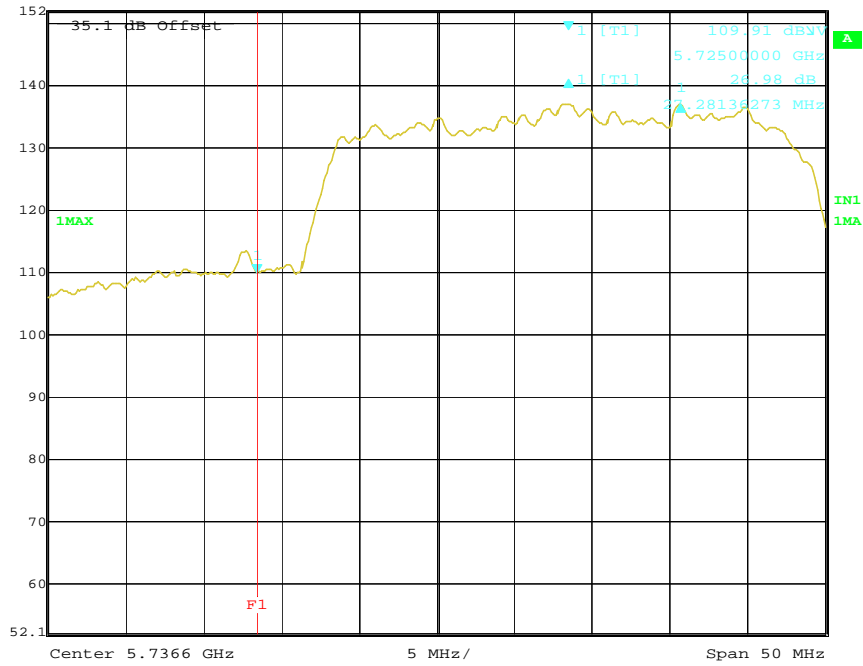

Date: 16.JUL.2009 15:20:58

Low Channel (32MHz Mode 1)

Delta 1 [T1] RBW 1 MHz RF Att 20 dB
Ref Lvl 26.01 dB VBW 1 MHz
152.1 dBV 19.76633267 MHz SWT 5 ms Unit dBV

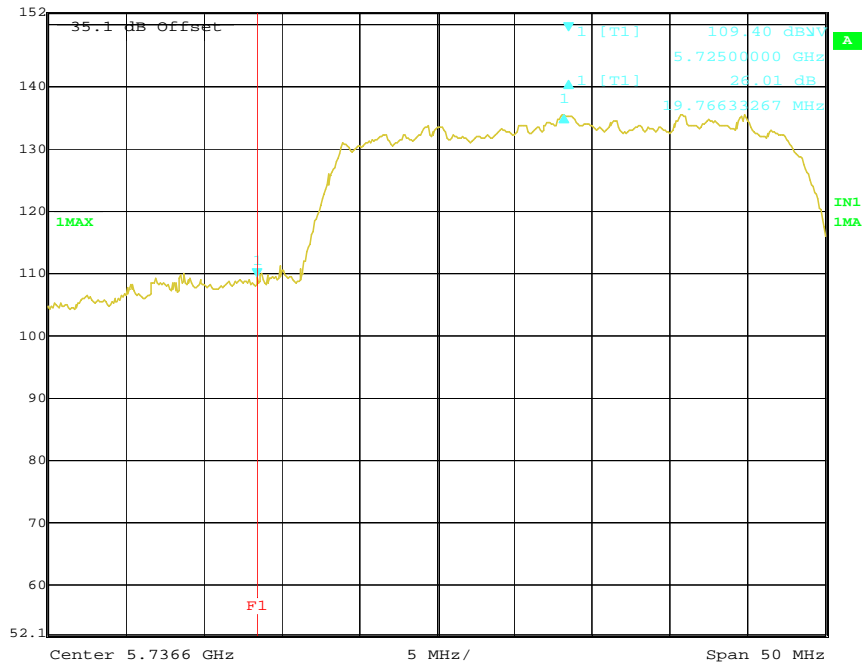

Date: 16.JUL.2009 15:12:20

Low Channel (32MHz Mode 2)



FS Delta 1 [T1] RBW 1 MHz RF Att 20 dB
Ref Lvl 24.55 dB VBW 1 MHz
152.1 dBmV 19.56593186 MHz SWT 5 ms Unit dBmV

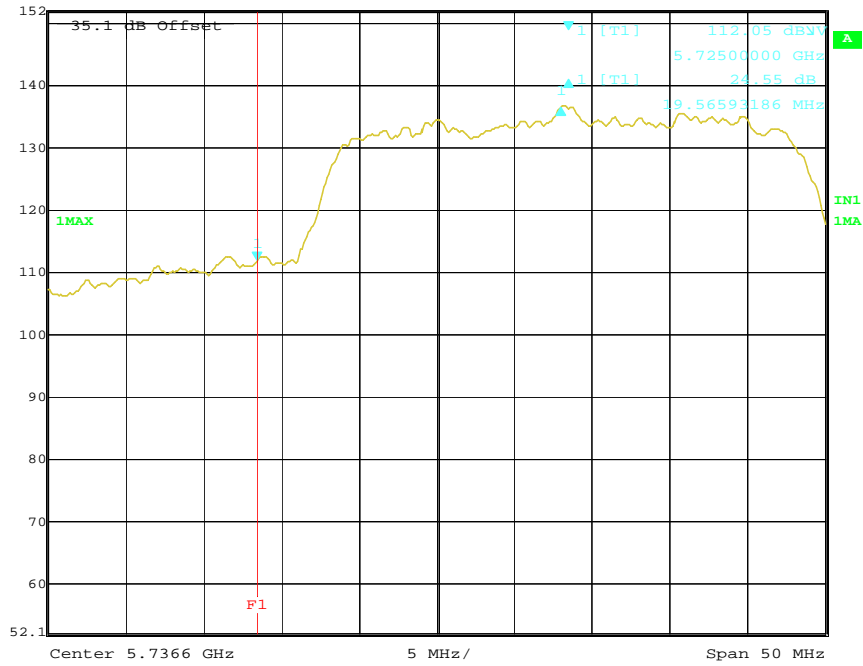

Date: 16.JUL.2009 15:11:02

Low Channel (32MHz Mode 3)

FS Delta 1 [T1] RBW 1 MHz RF Att 20 dB
Ref Lvl 28.60 dB VBW 1 MHz
152.1 dBmV -12.64829659 MHz SWT 5 ms Unit dBmV

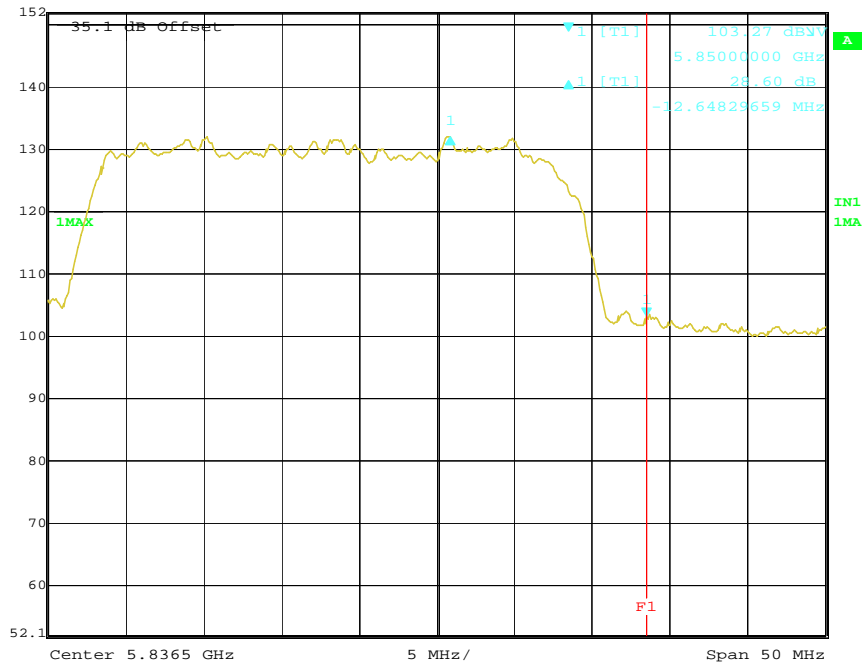

Date: 16.JUL.2009 16:02:49

High Channel (32MHz Mode 1)

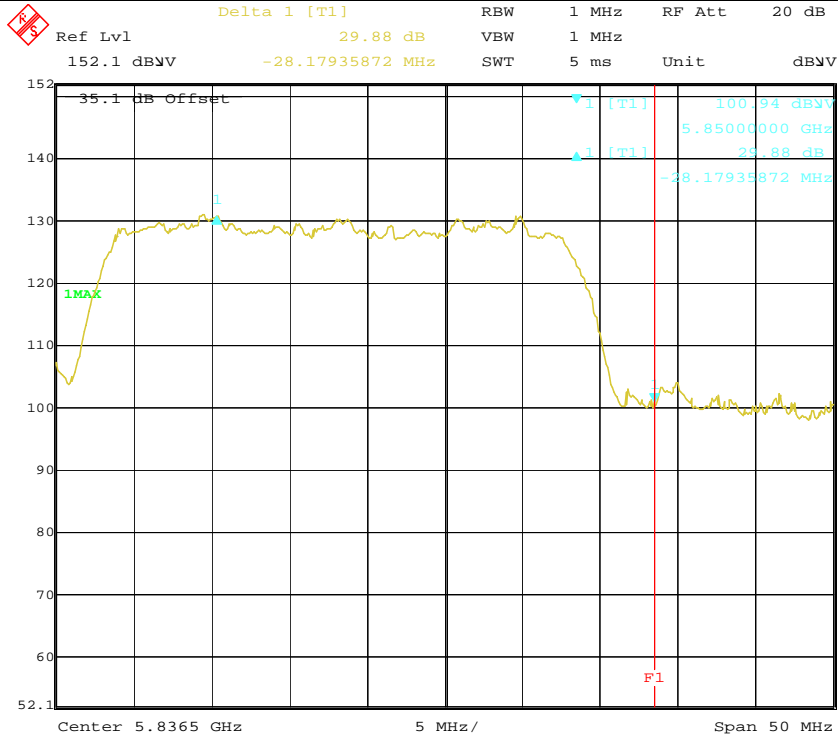

Date: 16.JUL.2009 15:33:32

High Channel (32MHz Mode 2)

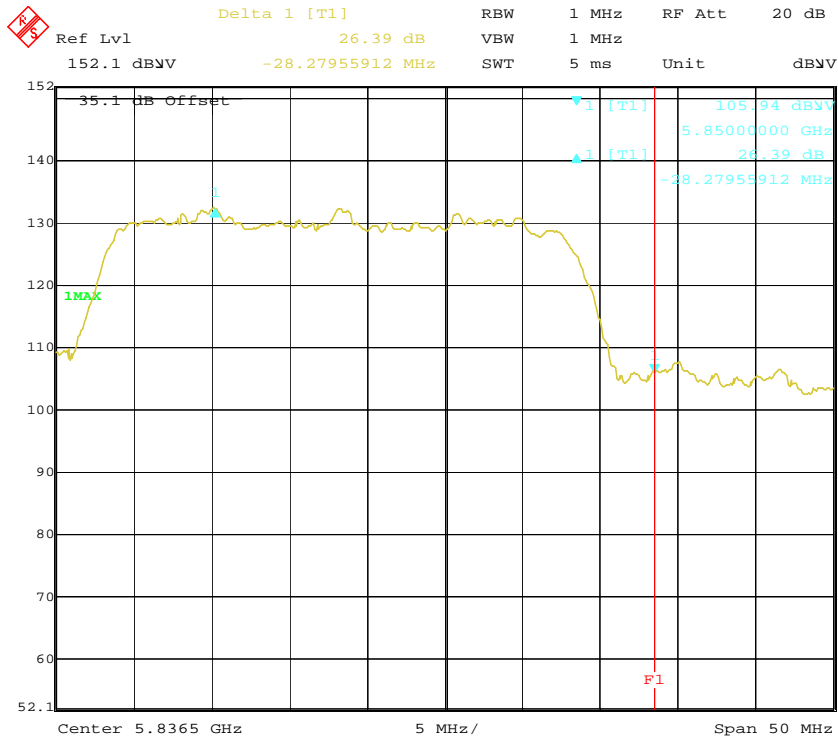

Date: 16.JUL.2009 16:01:18

High Channel (32MHz Mode 3)

Horizontal Polarity



Delta 1 [T1] RBW 1 MHz RF Att 20 dB
Ref Lvl 45.1 dBm 22.71 dB VBW 1 MHz
4.25490982 MHz SWT 5 ms Unit dBm

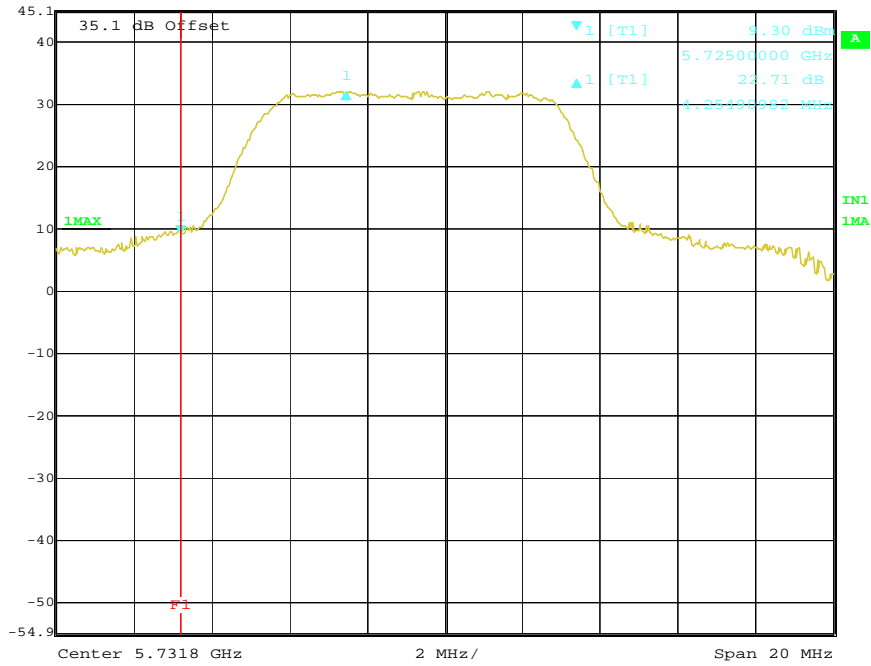

Date: 16.JUL.2009 17:24:09

Low Channel (8MHz Mode 1)

Delta 1 [T1] RBW 1 MHz RF Att 20 dB
Ref Lvl 45.1 dBm 23.84 dB VBW 1 MHz
3.29298597 MHz SWT 5 ms Unit dBm

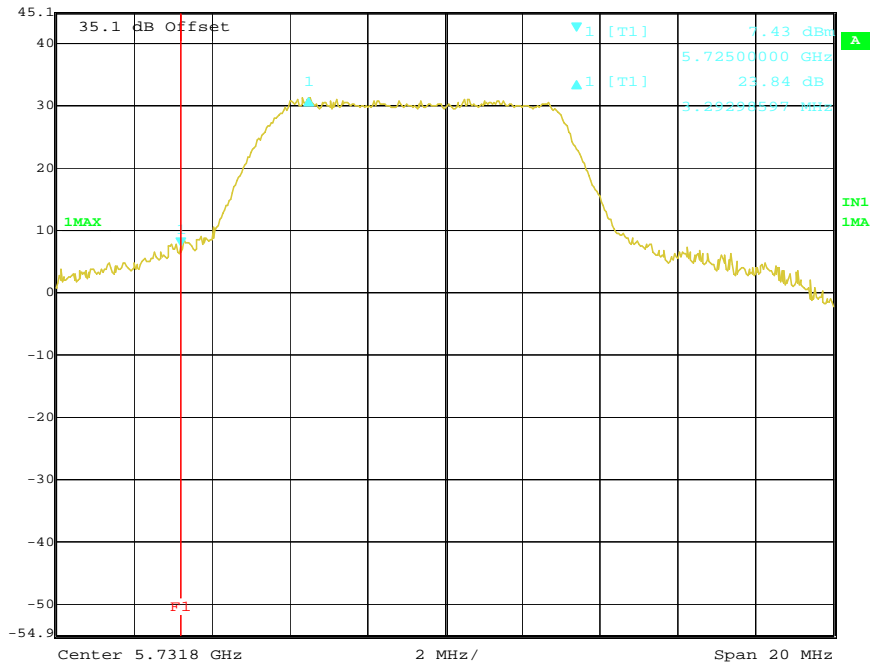

Date: 16.JUL.2009 17:25:19

Low Channel (8MHz Mode 2)

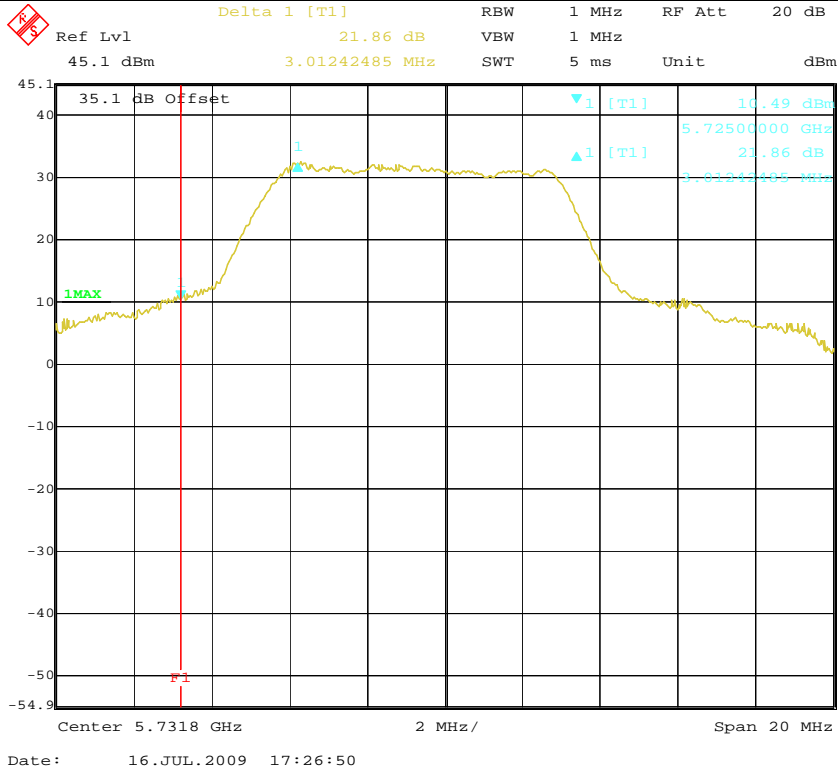

Low Channel (8MHz Mode 3)

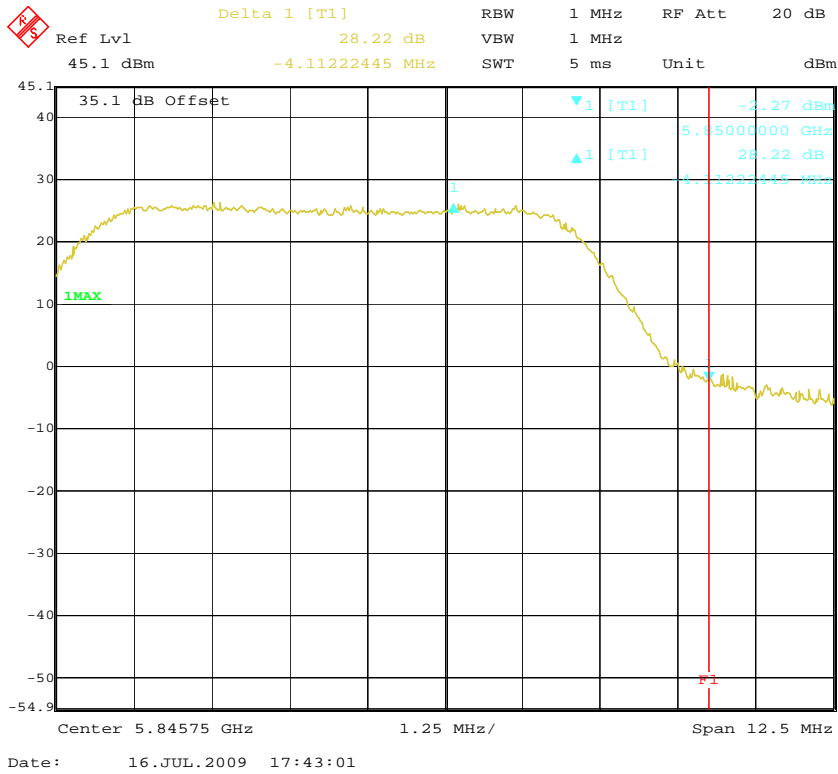

High Channel (8MHz Mode 1)

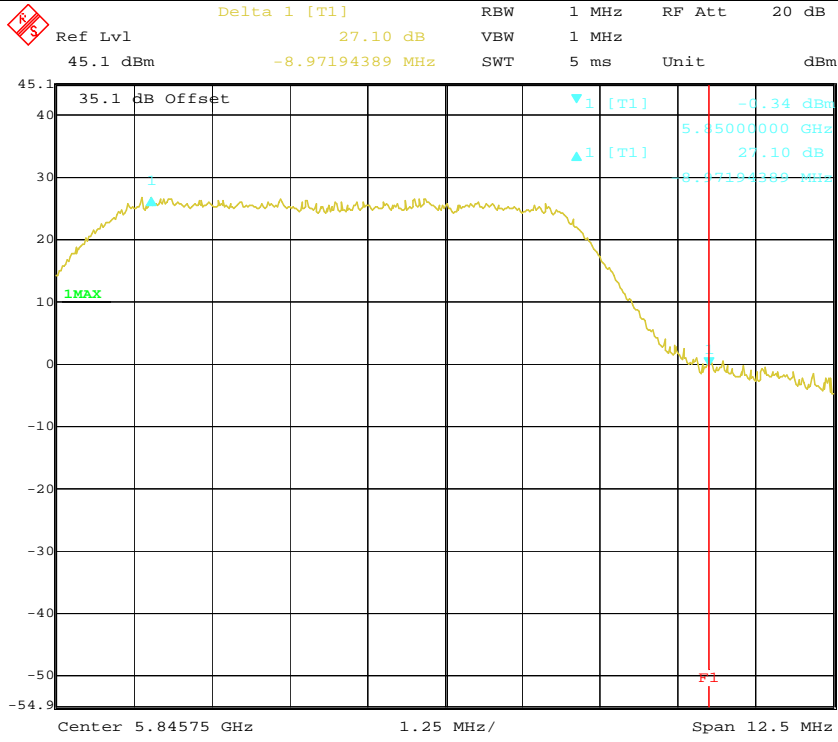

High Channel (8MHz Mode 2)

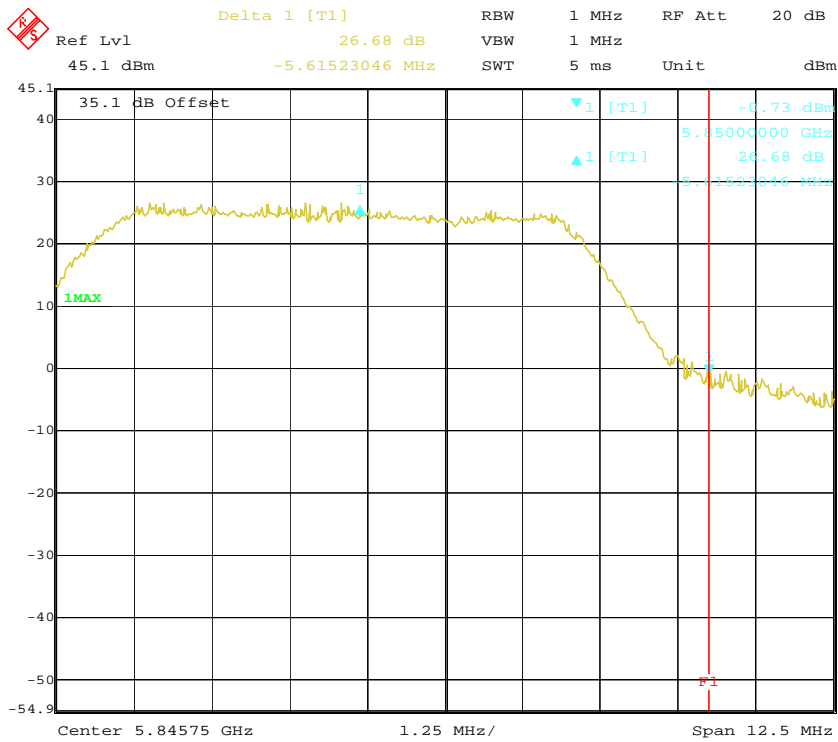

High Channel (8MHz Mode 3)



RS Delta 1 [T1] RBW 1 MHz RF Att 20 dB
Ref Lvl 38.22 dB VBW 1 MHz
45.1 dBm 25.66012024 MHz SWT 5 ms Unit dBm

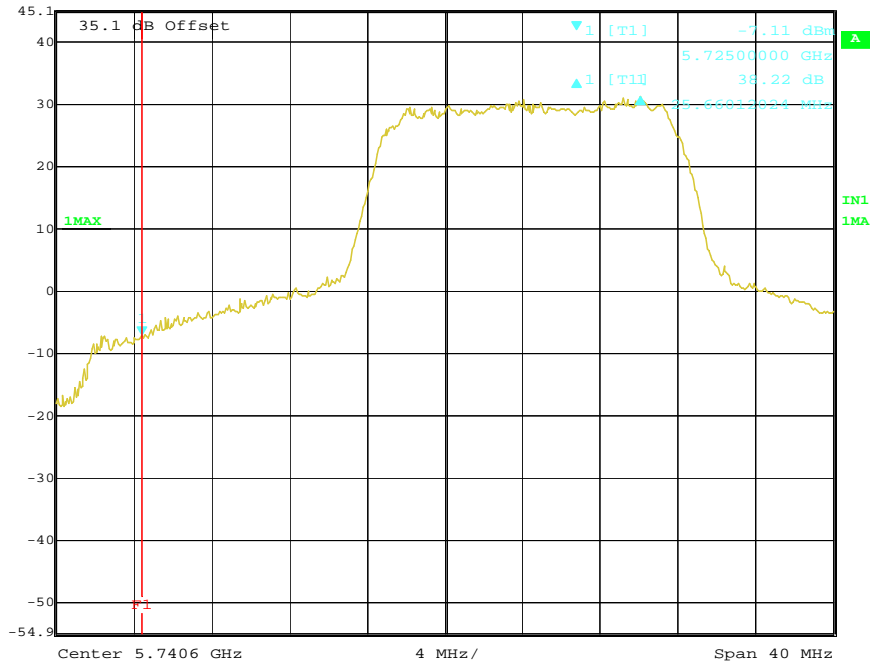

Date: 16.JUL.2009 17:16:02

Low Channel (16MHz Mode 1)

RS Delta 1 [T1] RBW 1 MHz RF Att 20 dB
Ref Lvl 37.54 dB VBW 1 MHz
45.1 dBm 26.78236473 MHz SWT 5 ms Unit dBm

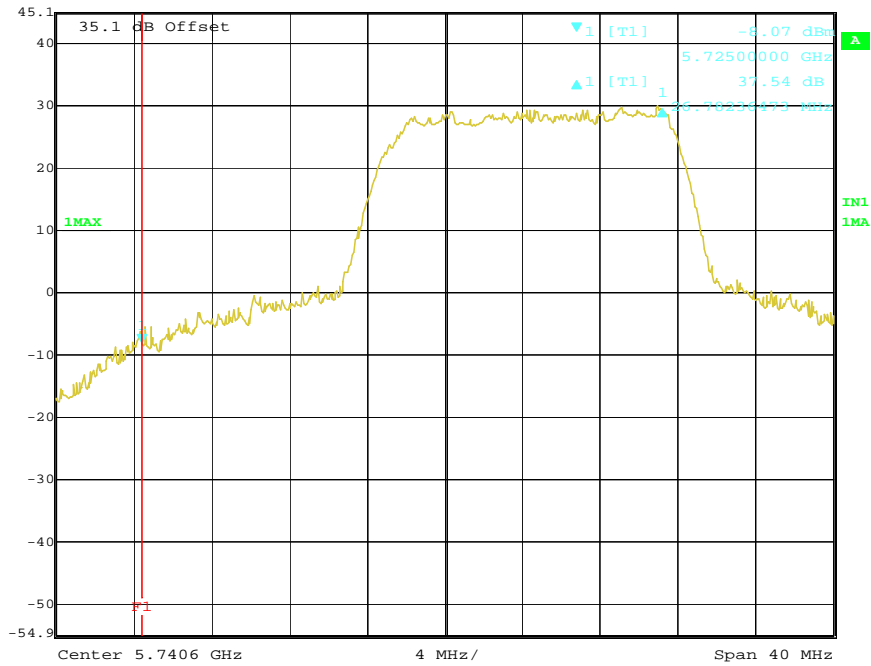

Date: 16.JUL.2009 17:15:06

Low Channel (16MHz Mode 2)



RS Delta 1 [T1] RBW 1 MHz RF Att 20 dB
Ref Lvl 32.21 dB VBW 1 MHz
45.1 dBm 19.88857715 MHz SWT 5 ms Unit dBm

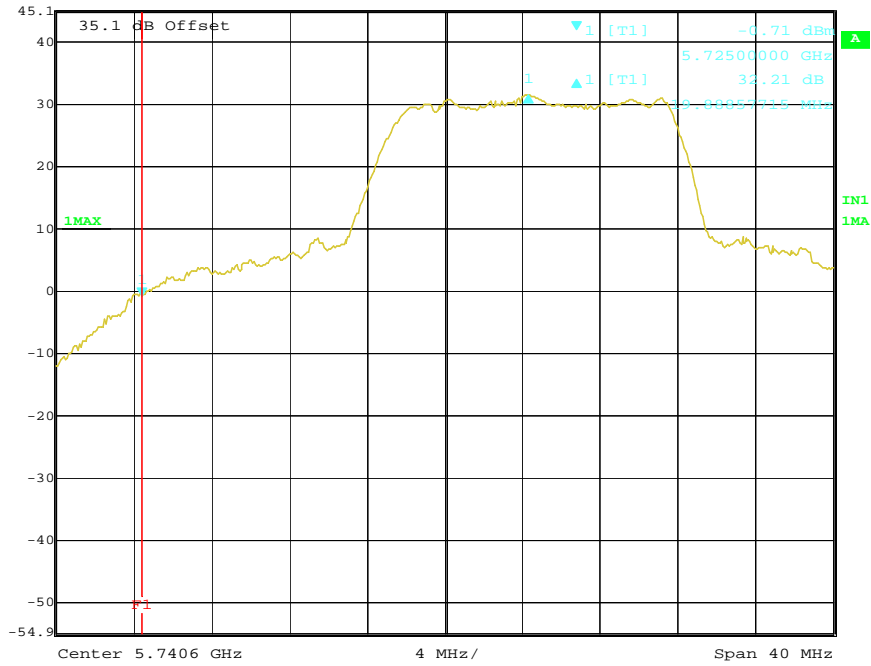

Date: 16.JUL.2009 17:14:10

Low Channel (16MHz Mode 3)

RS Delta 1 [T1] RBW 1 MHz RF Att 20 dB
Ref Lvl 30.33 dB VBW 1 MHz
45.1 dBm -16.29458918 MHz SWT 5 ms Unit dBm

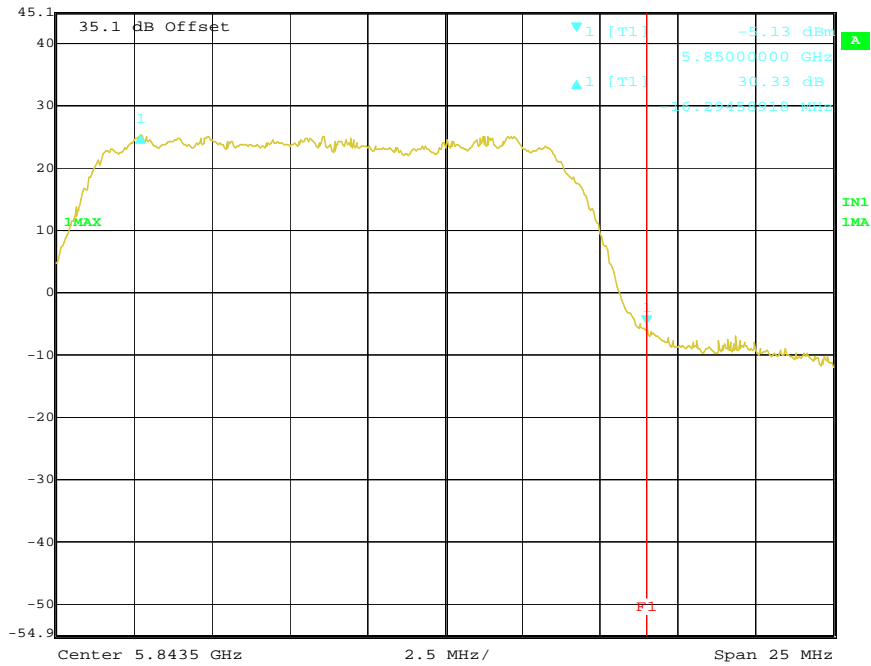

Date: 16.JUL.2009 17:37:08

High Channel (16MHz Mode 1)

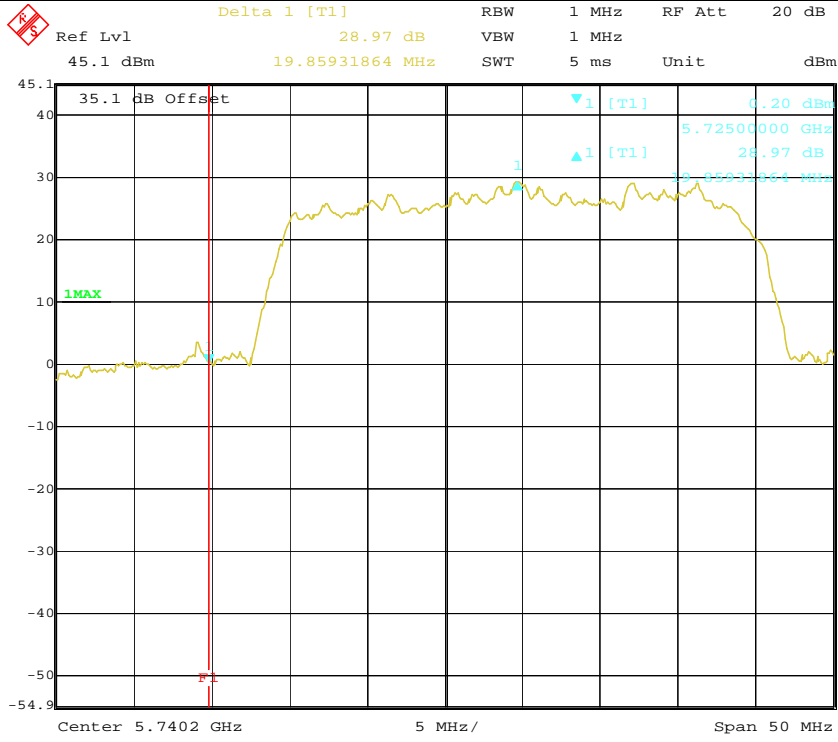

Low Channel (32MHz Mode 1)

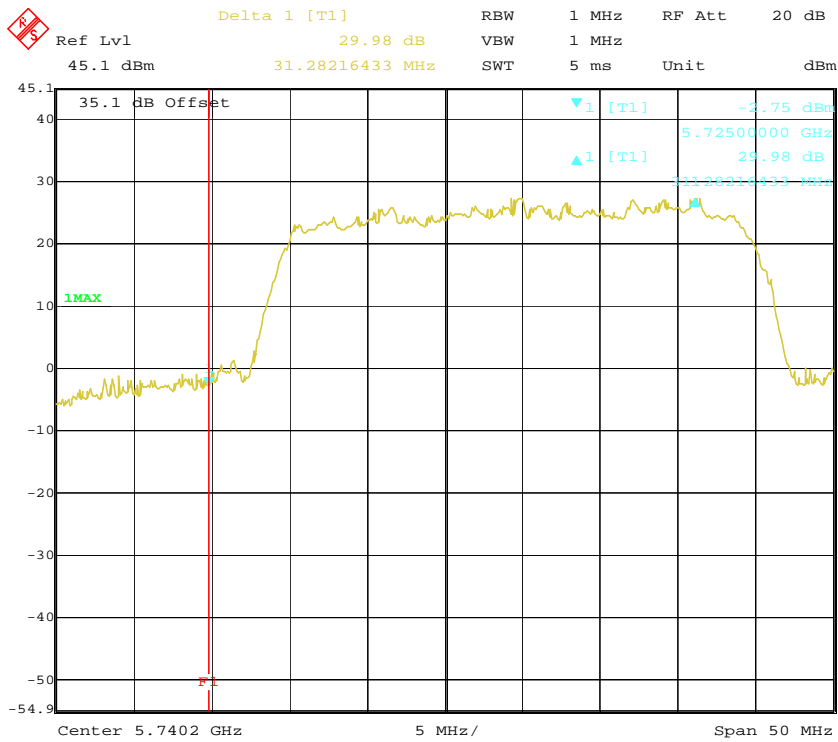

Low Channel (32MHz Mode 2)



RS Delta 1 [T1] RBW 1 MHz RF Att 20 dB
Ref Lvl 24.48 dB VBW 1 MHz
45.1 dBm 19.85931864 MHz SWT 5 ms Unit dBm

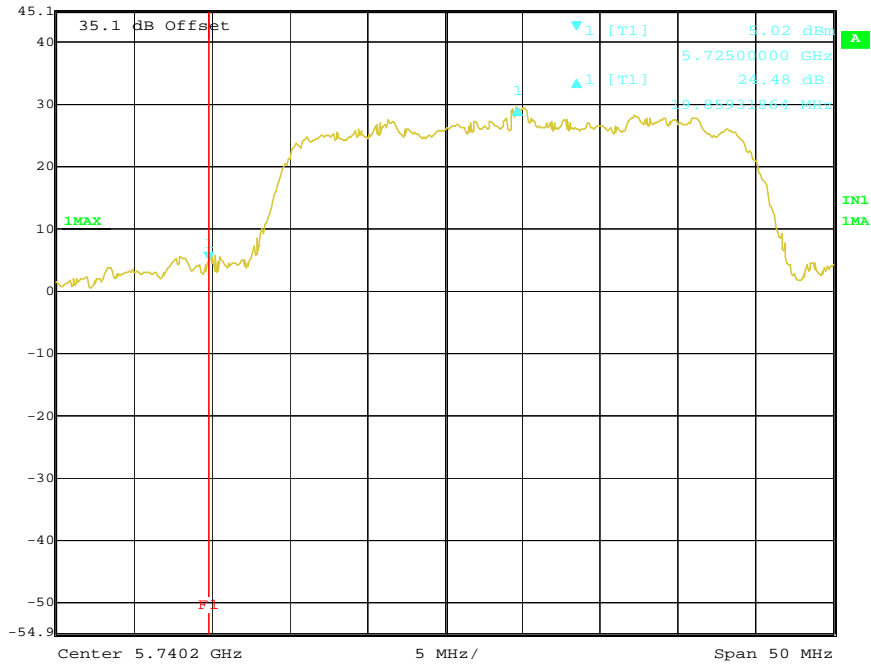

Date: 16.JUL.2009 17:29:55

Low Channel (32MHz Mode 3)

RS Delta 1 [T1] RBW 1 MHz RF Att 20 dB
Ref Lvl 29.75 dB VBW 1 MHz
45.1 dBm -28.37975952 MHz SWT 5 ms Unit dBm

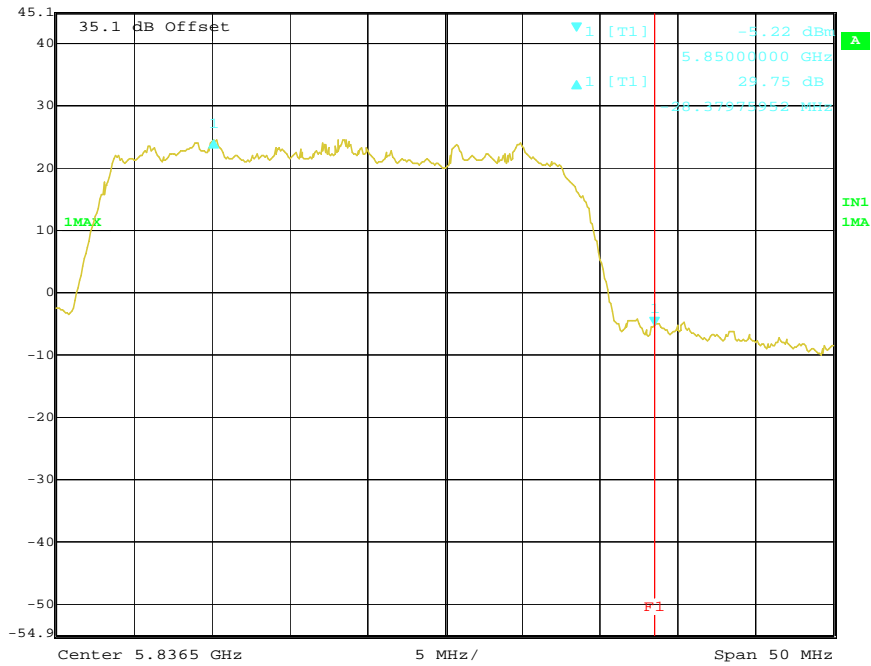

Date: 16.JUL.2009 17:33:14

High Channel (32MHz Mode 1)

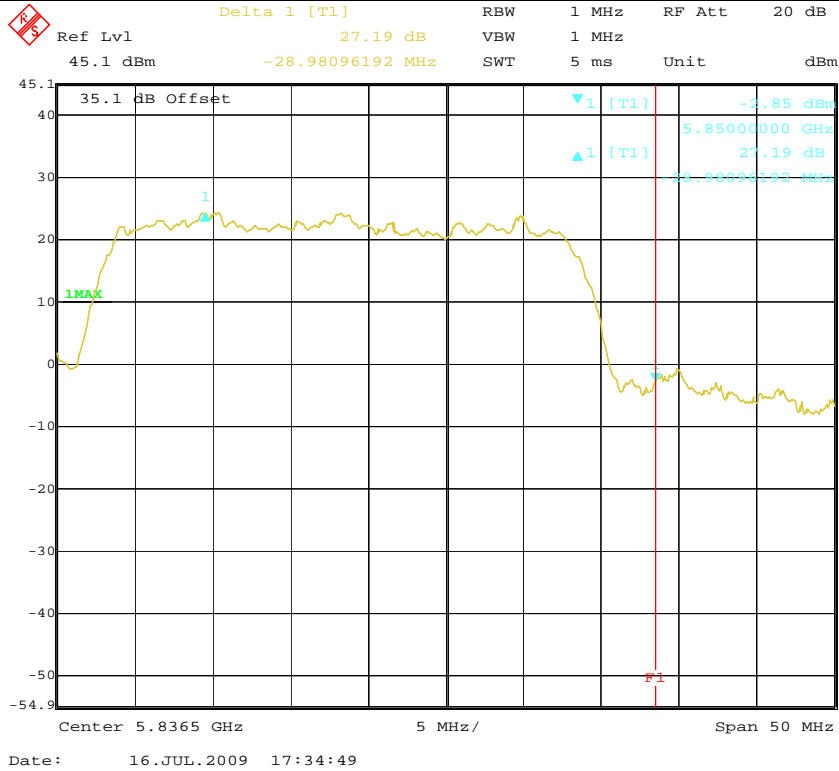

High Channel (32MHz Mode 2)

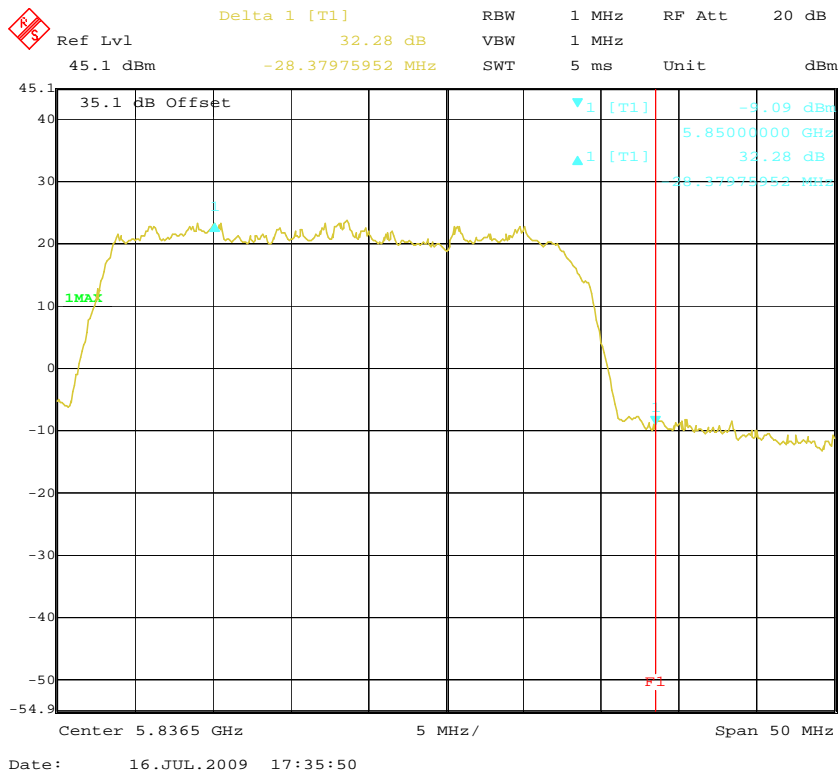

High Channel (32MHz Mode 3)

Annex A. TEST INSTRUMENT & METHOD

Annex A.i. TEST INSTRUMENTATION & GENERAL PROCEDURES

Instrument	Manufacturer	Model	CAL Due Date
Spectrum Analyzer	HP	8564E	04/26/2010
EMI Receiver	Rohde & Schwarz	ESIB 40	4/25/2010
R&S LISN	R&S	ESH2-Z5	04/24/2010
CHASE LISN	Chase	MN2050B	04/24/2010
Antenna(1 ~18GHz)	Emco	3115	01/04/2010
Antenna (30MHz~2GHz)	Sunol Sciences	JB1	01/04/2010
Chamber	Lingren	3m	04/18/2010
Pre-Amplifier(1 ~ 26GHz)	HP	8449	04/24/2010
Horn Antenna (18~40GHz)	Com Power	AH-840	03/19/2010
Microwave Pre-Amp (18~40GHz)	Com Power	PA-840	03/19/2010

Note: No calibration required.

Annex A.ii. CONDUCTED EMISSIONS TEST DESCRIPTION

Test Set-up

1. The EUT and supporting equipment were set up in accordance with the requirements of the standard on top of a 1.5m x 1m x 0.8m high, non-metallic table, as shown in Annex B.
2. The power supply for the EUT was fed through a 50Ω/50μH EUT LISN, connected to filtered mains.
3. The RF OUT of the EUT LISN was connected to the EMI test receiver via a low-loss coaxial cable.
4. All other supporting equipments were powered separately from another main supply.

Test Method

1. The EUT was switched on and allowed to warm up to its normal operating condition.
2. A scan was made on the NEUTRAL line (for AC mains) or Earth line (for DC power) over the required frequency range using an EMI test receiver.
3. High peaks, relative to the limit line, were then selected.
4. The EMI test receiver was then tuned to the selected frequencies and the necessary measurements made with a receiver bandwidth setting of 10 KHz. For FCC tests, only Quasi-peak measurements were made; while for CISPR/EN tests, both Quasi-peak and Average measurements were made.
5. Steps 2 to 4 were then repeated for the LIVE line (for AC mains) or DC line (for DC power).

Sample Calculation Example

At 20 MHz	limit = 250 μV = 47.96 dBμV
Transducer factor of LISN, pulse limiter & cable loss at 20 MHz = 11.20 dB	
Q-P reading obtained directly from EMI Receiver = 40.00 dBμV	
	(Calibrated for system losses)
Therefore, Q-P margin = 47.96 – 40.00 = 7.96	i.e. 7.96 dB below limit

Annex A. iii RADIATED EMISSIONS TEST DESCRIPTION

EUT Characterisation

EUT characterisation, over the frequency range from 30MHz to 10th Harmonic , was done in order to minimise radiated emissions testing time while still maintaining high confidence in the test results.

The EUT was placed in the chamber, at a height of about 0.8m on a turntable. Its radiated emissions frequency profile was observed, using a spectrum analyzer /receiver with the appropriate broadband antenna placed 3m away from the EUT. Radiated emissions from the EUT were maximised by rotating the turntable manually, changing the antenna polarisation and manipulating the EUT cables while observing the frequency profile on the spectrum analyzer / receiver. Frequency points at which maximum emissions occurred, clock frequencies and operating frequencies were then noted for the formal radiated emissions test at the Open Area Test Site (OATS).

Test Set-up

1. The EUT and supporting equipment were set up in accordance with the requirements of the standard on top of a 1.5m X 1.0m X 0.8m high, non-metallic table.
2. The filtered power supply for the EUT and supporting equipment were tapped from the appropriate power sockets located on the turntable.
3. The relevant broadband antenna was set at the required test distance away from the EUT and supporting equipment boundary.

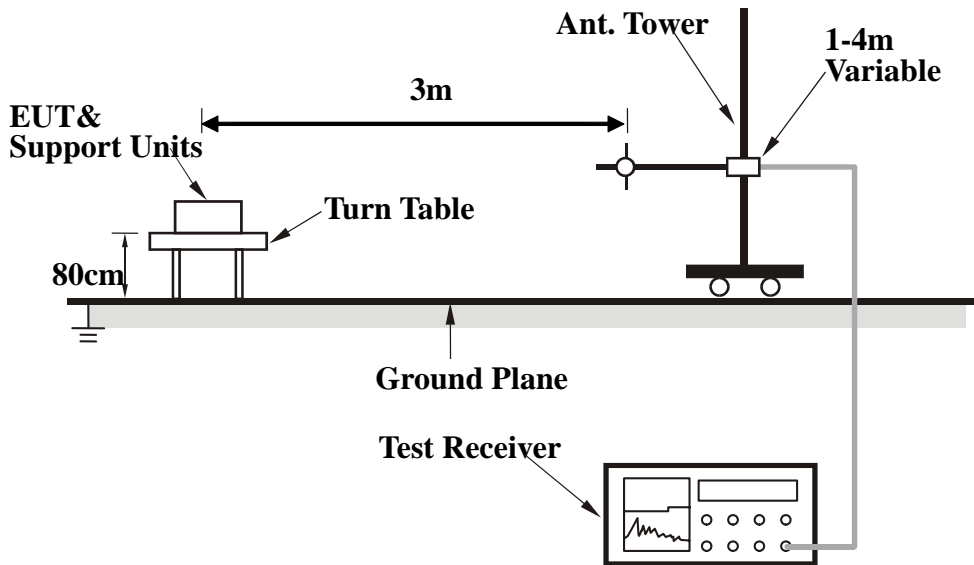

Test Method

The following procedure was performed to determine the maximum emission axis of EUT:

1. With the receiving antenna is H polarization, rotate the EUT in turns with three orthogonal axes to determine the axis of maximum emission.
2. With the receiving antenna is V polarization, rotate the EUT in turns with three orthogonal axes to determine the axis of maximum emission.
3. Compare the results derived from above two steps. So, the axis of maximum emission from EUT was determined and the configuration was used to perform the final measurement.

Final Radiated Emission Measurement

1. Setup the configuration according to figure 1. Turn on EUT and make sure that it is in normal function.
2. For emission frequencies measured below 1 GHz, a pre-scan is performed in a shielded chamber to determine the accurate frequencies of higher emissions will be checked on a open test site. As the same purpose, for emission frequencies measured above 1 GHz, a pre-scan also be performed with a 1 meter measuring distance before final test.
3. For emission frequencies measured below and above 1 GHz, set the spectrum analyzer on a 100 kHz and 1 MHz resolution bandwidth respectively for each frequency measured in step 2.
4. The search antenna is to be raised and lowered over a range from 1 to 4 meters in horizontally polarized orientation. Position the highness when the highest value is indicated on spectrum analyzer, then change the orientation of EUT on test table over a range from 0° to 360° with a speed as slow as possible, and keep the azimuth that highest emission is indicated on the spectrum analyzer. Vary the antenna position again and record the highest value as a final reading.
5. Repeat step 4 until all frequencies need to be measured were complete.
6. Repeat step 5 with search antenna in vertical polarized orientations.

During the radiated emission test, the Spectrum Analyzer was set with the following configurations:

Frequency Band (MHz)	Function	Resolution bandwidth	Video Bandwidth
30 to 1000	Peak	100 kHz	100 kHz
Above 1000	Peak	1 MHz	1 MHz
	Average	1 MHz	10 Hz

Sample Calculation Example

The field strength is calculated by adding the Antenna Factor and Cable Factor, and subtracting the Amplifier Gain (if any) from the measured reading. For the limit is employed average value, therefore the peak value can be transferred to average value by subtracting the duty factor. The basic equation with a sample calculation is as follows:

$$\text{Peak} = \text{Reading} + \text{Corrected Factor}$$

where

$$\text{Corr. Factor} = \text{Antenna Factor} + \text{Cable Factor} - \text{Amplifier Gain (if any)}$$

And the average value is

$$\text{Average} = \text{Peak Value} + \text{Duty Factor or}$$

$$\text{Set RBW} = 1\text{MHz, VBW} = 10\text{Hz.}$$

Note :

If the measured frequencies are fall in the restricted frequency band, the limit employed must be quasi peak value when frequencies are below or equal to 1 GHz. And the measuring instrument is set to quasi peak detector function.

Annex B EUT AND TEST SETUP PHOTOGRAPHS

Please see the attachment

Annex C. TEST SETUP AND SUPPORTING EQUIPMENT

EUT TEST CONDITIONS

Annex C. i. SUPPORTING EQUIPMENT DESCRIPTION

The following is a description of supporting equipment and details of cables used with the EUT.

Equipment Description (Including Brand Name)	Model & Serial Number	Cable Description (List Length, Type & Purpose)
N/A	N/A	N/A

Remarks: The device does not have any supporting equipment, but it is controlled by itself when performing the compliance evaluations.

Block Configuration Diagram for Radiated Emission

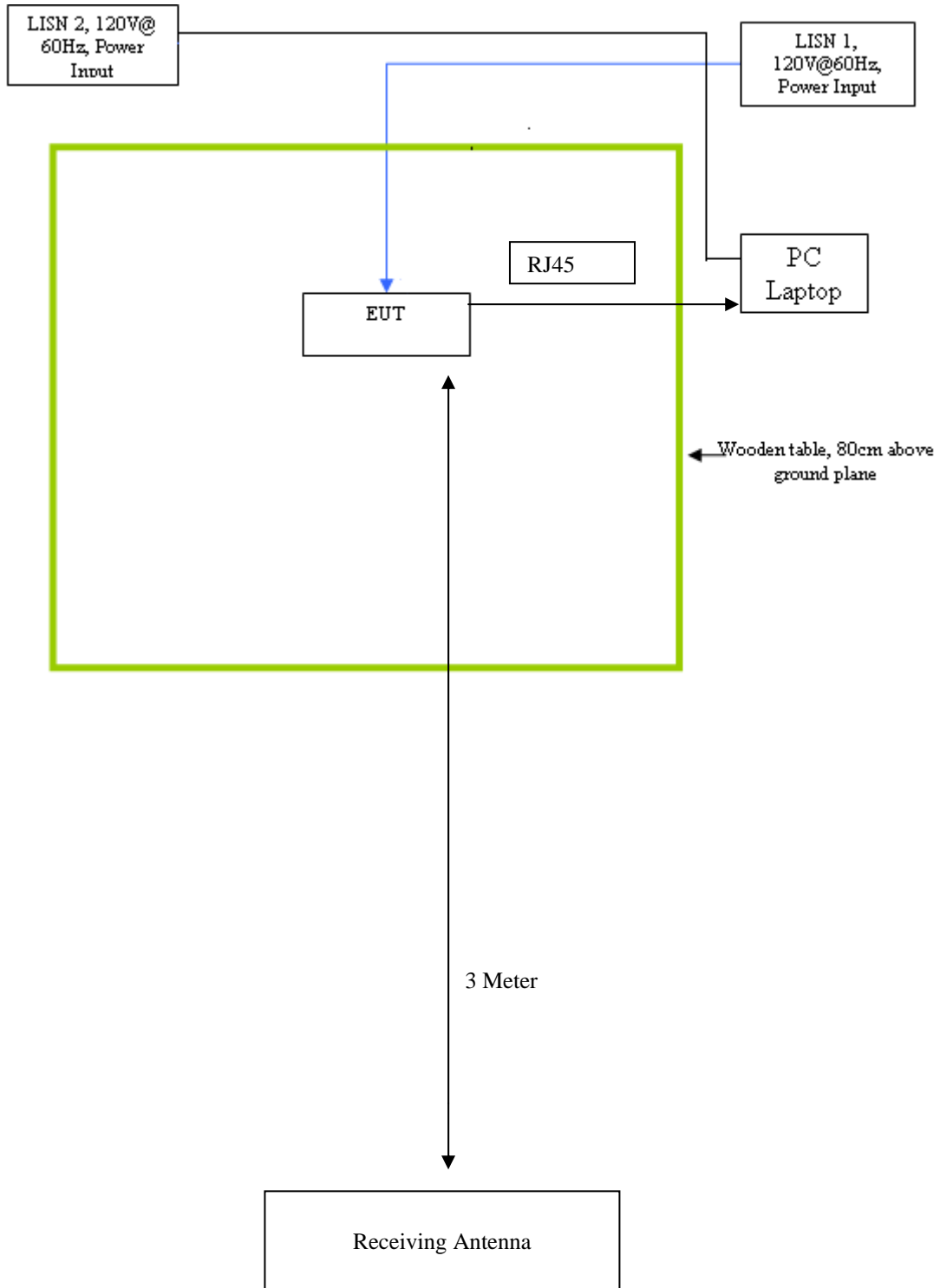

Block Configuration Diagram for Conducted Emission

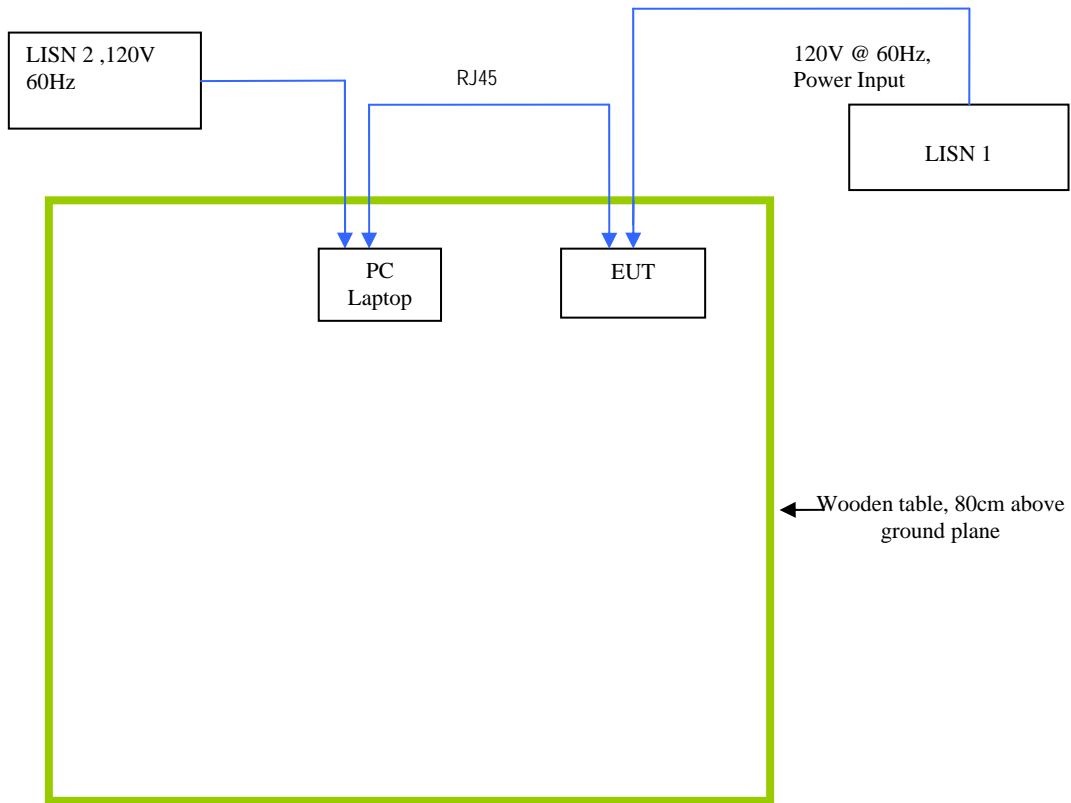



Annex C.ii. EUT OPERATING CONDITIONS

The following is the description of how the EUT is exercised during testing.

Test	Description Of Operation
Emissions Testing	The EUT was controlled by itself Using manufacturer's program.
Others Testing	TX mode is normal mode with full power.



SIEMIC, Inc.
Accessing global markets

Title: RF Test Report Exalt Communications, Inc., model : EX-5i
To: FCC 15.247 2009, RSS 210 Issue 7: 2007

Serial# SL09061401-EXT-004
Issue Date 27 July 2009
Page 125 of 140
www.sieminc.com

Annex D USER MANUAL, BLOCK & CIRCUIT DIAGRAM

Please see attachment

Annex E SIEMIC ACCREDITATION

SIEMIC ACREDITATION DETAILS: A2LA 17025 & ISO Guide 65 : 2742.01 , 2742.2

		THE AMERICAN ASSOCIATION FOR LABORATORY ACCREDITATION
ACCREDITED LABORATORY		
A2LA has accredited SIEMIC LABORATORIES San Jose, CA for technical competence in the field of Electrical Testing		
This laboratory is accredited in accordance with the recognized International Standard ISO/IEC 17025:2005 <i>General Requirements for the Competence of Testing and Calibration Laboratories</i> . This accreditation demonstrates technical competence for a defined scope and the operation of a laboratory quality management system (<i>refer to joint ISO-ILAC-IAF Communiqué dated 18 June 2005</i>).		
	Presented this 11th day of July 2008.  President For the Accreditation Council Certificate Number 2742.01 Valid to September 30, 2010	
For the tests or types of tests to which this accreditation applies, please refer to the laboratory's Electrical Scope of Accreditation.		

	THE AMERICAN ASSOCIATION FOR LABORATORY ACCREDITATION
ACCREDITED PRODUCT CERTIFICATION BODY	
A2LA has accredited SIEMIC INC. San Jose, CA for technical competence as a Product Certification Body	
This product certification body is accredited in accordance with the recognized International Standard ISO/IEC Guide 65:1996 <i>General requirements for bodies operating product certification systems</i> . This accreditation demonstrates technical competence for a defined scope and the operation of a quality management system for a Telecommunications Certification Body (TCB) meeting FCC (U.S.), IDA (Singapore) and IC (Canada) requirements.	
	Presented this 9 th day of January 2009.  President For the Accreditation Council Certificate Number: 2742.02 Valid to: September 30, 2010
For the product certification schemes to which this accreditation applies, please refer to the certification body's Scope of Accreditation.	



SCOPE OF ACCREDITATION TO ISO/IEC GUIDE 65:1996

SIEMIC INC.
2206 Ringwood Ave.
San Jose, CA 95131
Mr. Snell Leong (Authorized Representative) Phone: 408 526 1188
www.siemic.com

PRODUCT CERTIFICATION CONFORMITY ASSESSMENT BODY (CAB)

Valid to: September 30, 2010

Certificate Number: 2742.02

In recognition of the successful completion of the A2LA Certification Body Accreditation Program evaluation, including the US Federal Communications Commission (FCC), Industry Canada (IC) and Singapore (IDA) requirements for the indicated types of product certifications, accreditation is granted to this organization to perform the following product certification schemes:

Economy

Scope

Federal Communication Commission - (FCC)

Unlicensed Radio Frequency Devices	A1, A2, A3, A4
Licensed Radio Frequency Devices	B1, B2, B3, B4
Telephone Terminal Equipment	C

**Please refer to FCC TCB Program Roles and Responsibilities, v04, released February 14, 2008 detailing scopes, roles and responsibilities. <http://www.fcc.gov/oet/ea/FCC-Overview-TCB-Program.pdf>*

Industry Canada - (IC)

Radio All Radio Standards Specifications (RSS) in Category I Equipment Standards List Radio

**Please refer to Industry Canada (IC) website at: http://www.ic.gc.ca/epic/site/smt-gst.nsf/en/h_sf01342e.html*

IDA – Singapore

Line Terminal Equipment All Technical Specifications for Line Terminal Equipment – Table 1 of IDA MRA Recognition Scheme: 2008, Annex 2

Radio-Communication Equipment All Technical Specifications for Radio-Communication Equipment – Table 2 of IDA MRA Recognition Scheme: 2008, Annex 2

**Please refer to Info-Communication Development Authority (IDA) Singapore website at: http://www.ida.gov.sg/doc/Policies%20and%20Regulation/Policies_and_Regulation_Level2/20060609145118/MRARecScheme.pdf*



SIEMIC ACREDITATION DETAILS: FCC Test Site Registration No. 783147

FEDERAL COMMUNICATIONS COMMISSION

Laboratory Division
7435 Oakland Mills Road
Columbia, MD 21046

December 20, 2007

Registration Number: 783147

SIEMIC Laboratories
2206 Ringwood Avenue,
San Jose, CA 95131

Attention: Leslie Bai

Re: Measurement facility located at San Jose
3 & 10 meter site
Date of Renewal: December 20, 2007

Dear Sir or Madam:

Your request for renewal of the registration of the subject measurement facility has been received. The information submitted has been placed in your file and the registration has been renewed. The name of your organization will remain on the list of facilities whose measurement data will be accepted in conjunction with applications for Certification under Parts 15 or 18 of the Commission's Rules. Please note that the file must be updated for any changes made to the facility and the registration must be renewed at least every three years.

Measurement facilities that have indicated that they are available to the public to perform measurement services on a fee basis may be found on the FCC website www.fcc.gov under E-Filing, OET Equipment Authorization Electronic Filing, Test Firms.

Sincerely,

Phyllis Parrish
Industry Analyst



Title: RF Test Report Exalt Communications, Inc., model : EX-5i
To: FCC 15.247 2009, RSS 210 Issue 7: 2007

Serial# SL09061401-EXT-004
Issue Date 27 July 2009
Page 129 of 140
www.sieminc.com

SIEMIC ACREDITATION DETAILS: Industry of Canada CAB ID : US0160



UNITED STATES DEPARTMENT OF COMMERCE
National Institute of Standards and Technology
Gaithersburg, Maryland 20899

March 4, 2009

Mr. Leslie Bai
SIEMIC, Inc.
2206 Ringwood Avenue
San Jose, CA 95131

Dear Mr. Bai:

NIST is pleased to inform you that your laboratory has been recognized by Industry Canada (IC), under the Asia Pacific Economic Cooperation for Telecommunications Equipment Mutual Recognition Arrangement (APEC Tel MRA). Your laboratory is now designated to act as a Conformity Assessment Body (CAB) under Appendix B, **Phase I** Procedures, of the APEC Tel MRA. The pertinent information about your laboratory's designation is as follows:

CAB Name: SIEMIC, Inc.
Physical Location: 2206 Ringwood Avenue, San Jose, CA 95131 USA
Identification No.: US0160
Recognized Scope: CS-03 Part I, II, V, VI, VII and VIII

You may submit test data to IC to verify that the equipment to be imported into Canada satisfies the applicable requirements. The designation of your organization will remain in force as long as its accreditation for the designated scope remains valid and comply with the designation requirements.

Recognized CABs are listed on the NIST website at <http://ts.nist.gov/mra>. Please contact Ms. Ramona Saar at (301) 975-5521 or ramona.saar@nist.gov if you have any questions.

Sincerely,

David F. Alderman
Group Leader, Standards Coordination and Conformity Group
Standards Services Division

Enclosure

cc: CAB Program Manager



SIEMIC ACREDITATION DETAILS: Industry of Canada Test Site Registration No. 4842-1

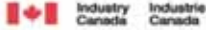

May 23rd, 2008

OUR FILE: 46405-4842
Submission No: 126429

Siemic Inc.
2206 Ringwood Ave.
San Jose CA 95131
USA

Attention: Leslie Bai

Dear Sir/Madame:

The Bureau has received your application for the registration / renewal of a 3/10m OATS. Be advised that the information received was satisfactory to Industry Canada. The following number(s) is now associated to the site(s) for which registration / renewal was sought (**4842A-1**). Please reference the appropriate site number in the body of test reports containing measurements performed on the site. In addition, please be informed that the Bureau is now utilizing a **new site numbering scheme** in order to simplify the electronic filing process. Our goal is to reduce the number of secondary codes associated to one particular company. The following changes have been made to your record.

- Your primary code is: **4842**
- The company number associated to the site(s) located at the above address is: **4842A**
- The table below is a summary of the changes made to the unique site registration number(s):

New Site Number	Obsolete Site Number	Description of Site	Expiry Date (YYYY-MM-DD)
4842A-1	4842-1	3m Chamber	2010-05-23

Furthermore, to obtain or renew a unique site number, the applicant shall demonstrate that the site has been accredited to ANSI C63.4-2003 or later. A scope of accreditation indicating the accreditation by a recognized accreditation body to ANSI C63.4-2003 shall be accepted. Please indicate in a letter the previous assigned site number if applicable and the type of site (example: 3 meter OATS or 3 meter chamber). If the test facility is not accredited to ANSI C63.4-2003 or later, the test facility shall submit test data demonstrating full compliance with the ANSI standard. The Bureau will evaluate the filing to determine if recognition shall be granted.

The frequency for re-validation of the test site and the information that is required to be filed or retained by the testing party shall comply with the requirements established by the accrediting organization. However, in all cases, test site re-validation shall occur on an interval not to exceed two years. There is no fee or form associated with an OATS filing. OATS submissions are encouraged to be submitted electronically to the Bureau using the following URL;
http://strategis.ic.gc.ca/epic/internet/inceb-bhst.nsf/en/h_t00052e.html.

If you have any questions, you may contact the Bureau by e-mail at certification_bureau@ic.gc.ca
Please reference our file and submission number above for all correspondence.

Yours sincerely,

S. Pronis
Test & Measurement Specialist
Certification and Engineering Bureau
3701 Carling Ave., Building 94
Ottawa, Ontario K2H 8S2



FEDERAL COMMUNICATIONS COMMISSION

**Laboratory Division
7435 Oakland Mills Road
Columbia, MD 21046**

August 28, 2008

**Siemic Laboratories
2206 Ringwood Ave.,
San Jose, CA 95131**

Attention: Leslie Bai

Re: Accreditation of Siemic Laboratories

**Designation Number: US1109
Test Firm Registration #: 540430**

Dear Sir or Madam:

We have been notified by American Association for Laboratory Accreditation that Siemic Laboratories has been accredited as a Conformity Assessment Body (CAB).

At this time Siemic Laboratories is hereby designated to perform compliance testing on equipment subject to Declaration Of Conformity (DOC) and Certification under Parts 15 and 18 of the Commission's Rules.

This designation will expire upon expiration of the accreditation or notification of withdrawal of designation.

Sincerely,

**George Tannahill
Electronics Engineer**



SIEMIC, Inc.
Accessing global markets

Title: RF Test Report Exalt Communications, Inc., model : EX-5i
To: FCC 15.247 2009, RSS 210 Issue 7: 2007

Serial# SL09061401-EXT-004
Issue Date 27 July 2009
Page 132 of 140
www.sieminc.com

SIEMIC ACREDITATION DETAILS: Australia CAB ID : US0160



UNITED STATES DEPARTMENT OF COMMERCE
National Institute of Standards and Technology
Gaithersburg, Maryland 20899

November 20, 2008

Mr. Leslie Bai
SIEMIC, Inc.
2206 Ringwood Avenue
San Jose, CA 95131

Dear Mr. Bai:

NIST is pleased to inform you that your laboratory has been recognized by the Australian Communications and Media Authority (ACMA) under the Asia Pacific Economic Cooperation for Telecommunications Equipment Mutual Recognition Arrangement (APEC Tel MRA). Your laboratory is now designated to act as a Conformity Assessment Body (CAB) under Appendix B, **Phase I** Procedures, of the APEC Tel MRA. The pertinent information about your laboratory's designation is as follows:

CAB Name: Siemic, Inc.
Physical Location: 2206 Ringwood Avenue, San Jose, CA 95131
Identification No.: US0160
Recognized Scope: EMC: AS/NZS 4251.1 (until 5/31/2009), AS/NZS 4251.2 (until 5/31/2009), AS/NZS CISPR 11, AS/NZS CISPR 14.1, AS/NZS CISPR 22, AS/NZS 61000.6.3, AS/NZS 61000.6.4
Radiocommunications: AS/NZS 4281, AS/NZS 4268, AS/NZS 4280.1, AS/NZS 4280.2, AS/NZS 4295, AS/NZS 4582, AS/NZS 4583, AS/NZS 4769.1, AS/NZS 4769.2, AS/NZS 4770, AS/NZS 4771
Telecommunications: AS/ACIF S002:05, AS/ACIF S003:06, AS/ACIF S004:06, AS/ACIF S006:01, AS/ACIF S016:01, AS/ACIF S031:01, AS/ACIF S038:01, AS/ACIF S040:01, AS/ACIF S041:05, AS/ACIF S043.2:06, AS/NZS 60950.1

You may submit test data to ACMA to verify that the equipment to be imported into Australia satisfies the applicable requirements. The designation of your organization will remain in force as long as its accreditation for the designated scope remains valid and comply with the designation requirements. Recognized CABs are listed on the NIST website at <http://ts.nist.gov/mra>. Please contact Ms. Ramona Saar, at (301) 975-5521 or ramona.saar@nist.gov if you have questions.

Sincerely,

David F. Alderman
Group Leader, Standards Coordination and Conformity Group
Standards Services Division

Enclosure

cc: Snell Leong, Siemic, Inc.; Ramona Saar, NIST

NIST



SIEMIC ACREDITATION DETAILS: Korea CAB ID: US0160



UNITED STATES DEPARTMENT OF COMMERCE
National Institute of Standards and Technology
Gaithersburg, Maryland 20899

October 1, 2008

Mr. Leslie Bai
SIEMIC, Inc.
2206 Ringwood Avenue
San Jose, CA 95131

Dear Mr. Bai:

NIST is pleased to inform you that your laboratory has been recognized by the Radio Research Agency (RRA) Korea Communications Commission (KCC) under the Asia Pacific Economic Cooperation for Telecommunications Equipment Mutual Recognition Arrangement (APEC Tel MRA). Your laboratory is now designated to act as a Conformity Assessment Body (CAB) under Appendix B, **Phase I** Procedures, of the APEC Tel MRA. The pertinent information about your laboratory's designation is as follows:

- CAB Name: SIEMIC, Inc.
- Physical Location: 2206 Ringwood Avenue, San Jose, CA 95131
- Identification No.: US0160
- Recognized Scope: **EMI:** KCC Notice 2008-39, RRL Notice 2008-3: CA Procedures for EMI
KN22: Test Method for EMI
- EMS:** KCC Notice 2008-38, RRL Notice 2008-4: CA Procedures for EMS
KN24, KN-61000-4-2, -4-3, -4-4, -4-5, -4-6, -4-8, -4-11: Test Method for EMS
- Wireless:** RRL Notice 2008-26, RRL Notice 2008-2, RRL Notice 2008-10,
RRL Notice 2007-49, RRL Notice 2007-20, RRL Notice 2007-21,
RRL Notice 2007-80, RRL Notice 2004-68
- Wired:** President Notice 20664, RRL Notice 2007-30,
RRL Notice 2008-7 with attachments 1, 3, 5, 6
President Notice 20664, RRL Notice 2008-7 with attachment 4

You may submit test data to RRA/KCC to verify that the equipment to be imported into Korea satisfies the applicable requirements. The designation of your organization will remain in force as long as its accreditation for the designated scope remains valid and comply with the designation requirements.

Recognized CABs are listed on the NIST website at <http://ts.nist.gov/mra>. If you have any questions please contact Ramona Saar at (301) 975-5521 or ramona.saar@nist.gov.

Sincerely,

David F. Alderman
Group Leader, Standards Coordination and Conformity Group
Standards Services Division

Enclosure

cc: Ramona Saar





SIEMIC ACREDITATION DETAILS: Taiwan BSMI Accreditation No. SL2-IN-E-1130R



UNITED STATES DEPARTMENT OF COMMERCE
National Institute of Standards and Technology
Gaithersburg, Maryland 20899

May 3, 2006

Mr. Leslie Bai
SIEMIC Laboratories
2205 Ringwood Avenue
San Jose, CA 95131

Dear Mr. Bai:

I am pleased to inform you that your laboratory has been recognized by the Chinese Taipei's Bureau of Standards, Metrology, and Inspection (BSMI) under the Asia Pacific Economic Cooperation (APEC) Mutual Recognition Arrangement (MRA). Your laboratory is now designated to act as a Conformity Assessment Body (CAB) under Appendix B, **Phase I** Procedures, of the APEC Tel MRA. You may submit test data to BSMI to verify that the equipment to be imported into Chinese Taipei satisfies the applicable requirements. The designation of your organization will remain in force as long as its accreditation for the designated scope remains valid and comply with the designation requirements. The pertinent designation information is as follows:

- BSMI number: **SL2-IN-E-1130R** (Must be applied to the test reports)
- U.S. Identification No: **US0160**
- Scope of Designation: **CNS 13438**
- Authorized signatory: **Mr. Leslie Bai**

The names of all recognized CABs will be posted on the NIST website at <http://ts.nist.gov/mra>. If you have any questions, please contact Mr. Dhillon at 301-975-5521. We appreciate your continued interest in our international conformity assessment activities.

Sincerely,

David F. Alderman
Group Leader, Standards Coordination and Conformity Group

cc: Jogindar Dhillon



SIEMIC, Inc.
Accessing global markets

Title: RF Test Report Exalt Communications, Inc., model : EX-5i
To: FCC 15.247 2009, RSS 210 Issue 7: 2007

Serial# SL09061401-EXT-004
Issue Date 27 July 2009
Page 135 of 140
www.sieminc.com

SIEMIC ACREDITATION DETAILS: Taiwan NCC CAB ID: US0160



UNITED STATES DEPARTMENT OF COMMERCE
National Institute of Standards and Technology
Gaithersburg, Maryland 20899

November 25, 2008

Mr. Leslie Bai
SIEMIC, Inc.
2206 Ringwood Avenue
San Jose, CA 95131

Dear Mr. Bai:

NIST is pleased to inform you that your laboratory has been recognized by the National Communications Commission (NCC) for the requested scope expansion under the Asia Pacific Economic Cooperation for Telecommunications Equipment Mutual Recognition Arrangement (APEC Tel MRA). Your laboratory is designated to act as a Conformity Assessment Body (CAB) under Appendix B, **Phase I** Procedures, of the APEC Tel MRA. The pertinent information about your laboratory's designation is as follows:

CAB Name: SIEMIC, Inc.
Physical Location: 2206 Ringwood Avenue, San Jose, CA 95131
Identification No.: US0160
Current Scope: LP0002
Additional Scope: PSTN01, ADSL01, ID0002, IS6100 and CNS 14336

You may submit test data to NCC to verify that the equipment to be imported into China satisfies the applicable requirements. The designation of your organization will remain in force as long as its accreditation for the designated scope remains valid and comply with the designation requirements.

Recognized CABs are listed on the NIST website at <http://ts.nist.gov/mra>. If you have any questions please contact Ramona Saar at (301) 975-5521 or ramona.saar@nist.gov.

Sincerely,

David F. Alderman
Group Leader, Standards Coordination and Conformity Group
Standards Services Division

Enclosure

cc: Ramona Saar

NIST



SIEMIC ACREDITATION DETAILS: Mexico NOM Recognition



CAMARA NACIONAL
DE LA INDUSTRIA
ELECTRONICA, DE
TELECOMUNICACIONES
E INFORMACION

Laboratorio Valentín V. Rivero

México D.F. a 18 de octubre de 2009.

**LESLIE BAI
DIRECTOR OF CERTIFICATION
SIEMIC LABORATORIES, INC.
ACCESSING GLOBAL MARKETS
P R E S E N T E**

En contestación a su escrito de fecha 5 de septiembre del año en curso, le comento que estamos muy interesados en su intención de firmar un Acuerdo de Reconocimiento Mutuo, para lo cual adjunto a este escrito encontrara el Acuerdo en idioma inglés y español prellenado de los cuales le pido sea revisado y en su caso corregido, para que si este de acuerdo poder firmarlo para mandarlo con las autoridades Mexicanas para su visto bueno y así poder ejercer dicho acuerdo.

Aprovecho este escrito para mencionarle que nuestro intermediario gestor será la empresa Isabel de México S. A. de C. V., empresa que ha colaborado durante mucho tiempo con nosotros en lo relacionado a la evaluación de la conformidad y que cuenta con amplia experiencia en la gestión de la certificación de cumplimiento con Normas Oficiales Mexicanas de producto en México.

Me despido de usted enviándole un cordial saludo y esperando sus comentarios al Acuerdo que nos ocupa.

Atentamente:



**Ing. Faustino Sánchez González
Gerente Técnico del Laboratorio de
CANIETI**



SIEMIC, Inc.
Accessing global markets

Title: RF Test Report Exalt Communications, Inc., model : EX-5i
To: FCC 15.247 2009, RSS 210 Issue 7: 2007

Serial# SL09061401-EXT-004
Issue Date 27 July 2009
Page 137 of 140
www.siemic.com

SIEMIC ACREDITATION DETAILS: Hong Kong OFTA CAB ID : US0160



UNITED STATES DEPARTMENT OF COMMERCE
National Institute of Standards and Technology
Gaithersburg, Maryland 20899-

December 8, 2008

Mr. Leslie Bai
SIEMIC, Inc.
2206 Ringwood Avenue
San Jose, CA 95131

Dear Mr. Bai:

NIST is pleased to inform you that your laboratory has been recognized by the Office of the Telecommunications Authority (OFTA) under the Asia Pacific Economic Cooperation for Telecommunications Equipment Mutual Recognition Arrangement (APEC Tel MRA). Your laboratory is now designated to act as a Conformity Assessment Body (CAB) under Appendix B, **Phase I** Procedures, of the APEC Tel MRA. The pertinent information about your laboratory's designation is as follows:

CAB Name: SIEMIC, Inc.
Physical Location: 2206 Ringwood Avenue, San Jose, California 95131 USA
Identification No.: US0160
Recognized Scope: **Radio:** HKTA 1002, 1007, 1008, 1010, 1015, 1016, 1020, 1022, 1026, 1027, 1029, 1030, 1031, 1032, 1033, 1034, 1035, 1036, 1037, 1039, 1041, 1042, 1043, 1044, 1046, 1047, 1048, 1049, 1051
Telecom: HKTA 2011, 2012, 2013, 2014, 2017, 2018, 2022, 2024, 2026, 2027, 2028, 2029, 2030, 2031, 2032, 2033

You may submit test data to OFTA to verify that the equipment to be imported into Hong Kong satisfies the applicable requirements. The designation of your organization will remain in force as long as its accreditation for the designated scope remains valid and comply with the designation requirements.

Recognized CABs are listed on the NIST website at <http://ts.nist.gov/mra>. If you have any questions please contact Ramona Saar at (301) 975-5521 or ramona.saar@nist.gov.

Sincerely,

David F. Alderman
Group Leader, Standards Coordination and Conformity Group
Standards Services Division

Enclosure

cc: Ramona Saar



VCCI Council

CERTIFICATE

Company: SIEMIC Inc.

<Member No. 3081 >

Facility: SIEMIC Inc.

(Radiation 3 meter site)

Location of Facility:

2206 Ringwood Avenue, San Jose, CA 95131 USA

*This is to certify that the following measuring facility
has been registered in accordance with the Rules
for Voluntary Control Measures*

Registration No.: R-3083

Date of Registration: June 12 , 2009

This Certificate is valid until September 30 , 2010

VCCI Council





VCCI Council

CERTIFICATE

Company: SIEMIC Inc.

<Member No. 3081 >

Facility: SIEMIC Inc.

(Main Ports Conducted Interference Measurement)

Location of Facility:

2206 Ringwood Avenue, San Jose, CA 95131 USA

*This is to certify that the following measuring facility
has been registered in accordance with the Rules
for Voluntary Control Measures*

Registration No.: C-3421

Date of Registration: June 12 , 2009

This Certificate is valid until September 30 , 2010

VCCI Council





VCCI Council

CERTIFICATE

Company: SIEMIC Inc.

<Member No. 3081 >

Facility: SIEMIC Inc.

(Telecommunication Ports Conducted Interference Measurement)

Location of Facility:

2206 Ringwood Avenue, San Jose, CA 95131 USA

*This is to certify that the following measuring facility
has been registered in accordance with the Rules
for Voluntary Control Measures*

Registration No.: T-1597

Date of Registration: June 12, 2009

This Certificate is valid until September 30, 2010

VCCI Council

