

1. General Description

Tire pressure sensor is composed of RF chip, battery, antenna and Rf matching network. It is applied to monitor tire pressure, temperature and acceleration and the tire data is transmitted via center frequency 433.92MHz.

2. Operation Functions

Transmitter ID Programming: transmitter ID can be programmed for easy replacement

Standard Pressure Programming: standard pressure for each tire can be programmed on monitor

3. Product Features

Powerful functions including low pressure alarms in 3 levels, fast leak alarm and standard pressure setting etc.

Monitor connects to continuous power to ensure full-time monitoring

Design of the whole system matches the truck perfectly

Simple operation for function programming and inquiry

4. Operating condition

Input Pressure Range	100kpa-450kpa
Supply Voltage	1.9 - 3.6V
Operating Temperature	-40 - 125°C
Z-axis Acceleration	355g Max
RF Frequency	433.92MHz

5. Installing structure

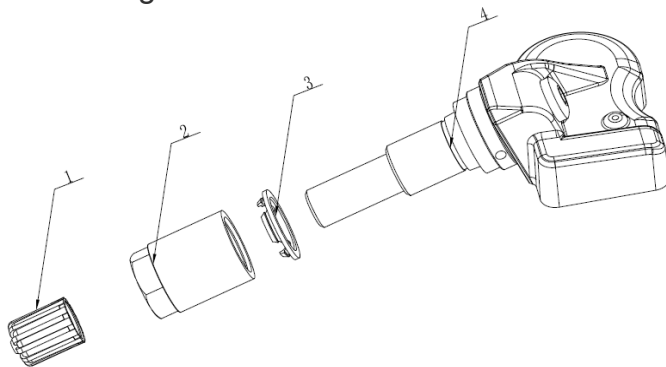

1. Valve rod

2. cushion

3. nut

4. valve cap

6. Installation requirements

TPMS Sensor

- User manual

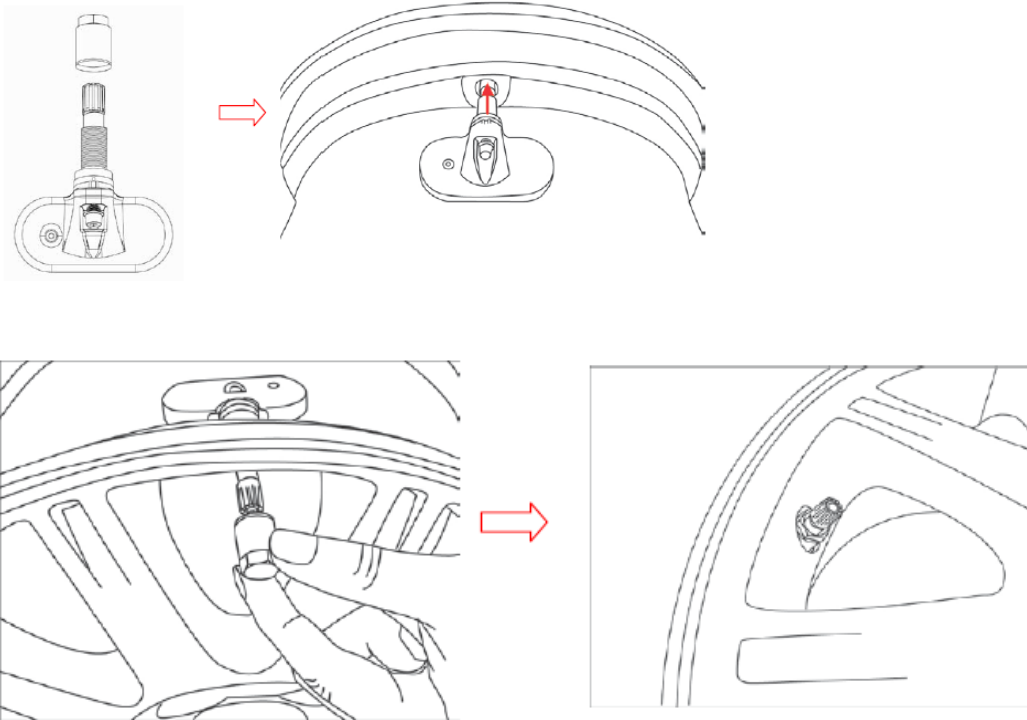

moment:5.0N.m($\pm 0.5N$)



Tires must do dynamic balance testing and adjusting.

Federal Communications Commission (FCC) Compliance Statement for USA

This device complies with part 15 of the FCC rules. Operation is subject to the following two conditions: (1) This device may not cause harmful interference, and (2) this device must accept any interference received, including interference that may cause undesired operation.

FCC Caution: Any changes or modifications not expressly approved by the party responsible for compliance could void the user's authority to operate this equipment.

This equipment has been tested and found to comply with the limits for a Class B digital device, pursuant to part 15 of the FCC Rules. These limits are designed to provide reasonable protection against harmful interference in a residential installation. This equipment generates, uses and can radiate radio frequency energy and, if not installed and used in accordance with the instructions, may cause harmful interference to radio communications. However, there is no guarantee that interference will not occur in a particular installation. If this equipment does cause harmful interference to radio or television reception, which can be determined by turning the equipment off and on, the user is encouraged to try to correct the interference by one or more of the following measures:

- Reorient or relocate the receiving antenna.
- Increase the separation between the equipment and receiver.
- Connect the equipment into an outlet on a circuit different from that to which the receiver is connected.
- Consult the dealer or an experienced radio/TV technician for help.

RF Exposure Warning

This equipment complies with FCC radiation exposure limits set forth for an uncontrolled environment.

This product may not be collocated or operated in conjunction with any other antenna or transmitter.